



Kundendienstschrift
Service manual

ALLGEMEINE TECHNISCHE ANGABEN

Netzteil

Energieversorgung: 1) 3 × 1,5 V Mignonzellen IEC R6
2) 4,5 V Netzgerät

Max. Stromaufnahme: < 50 mA

Brauchbare Batteriespannung: > 3 V

Radio

Wellenbereiche	Empfindlichkeit (S/R = 20 db)
UKW 87,35 ... 108,25 MHz	(S/R = 30 db) < 8 µV
MW 520 ... 1740 kHz	< 1,26 mV/m
KW1 5,85 ... 6,275 MHz	< 12,6 µV
KW2 7,00 ... 7,51 MHz	< 12,6 µV
KW3 9,44 ... 9,965 MHz	< 12,6 µV
KW4 11,57 ... 12,12 MHz	< 12,6 µV
KW5 13,52 ... 13,99 MHz	< 12,6 µV
KW6 15,00 ... 15,73 MHz	< 15,8 µV
KW7 17,42 ... 18,03 MHz	< 15,8 µV
KW8 21,35 ... 22,05 MHz	< 15,8 µV

Verzerrungen	Frequenzgang	S/R-Abstand
UKW (1 mV) < 4 %	(-3 db) < 250 ... 6300 Hz >	> 45 db
MW (5 mV) < 5 %	(-6 db) < 250 ... 2000 Hz >	> 30 db
KW1 ... KW8 (100 µV)	—	> 30 db

Verstärker

Ausgangsleistung (Gesamtklirrgrad = 10 %): > 120 mW
Maximale Ausgangsleistung: 180 mW
Ohrhörerbetrieb: 32 Ω / 2 × 10 mW

GENERAL TECHNICAL DATA

Power supply unit

Power supply: 1) 3 × 1.5 V cells IEC R6
2) 4.5 V AC/DC-adapter

Current consumption: < 50 mA

Lowes battery voltage: > 3 V

Radio

Ranges	Sensitivity (S/N = 20 db)
FM 87.35 ... 108.25 MHz	(S/N) = 30 db) < 8 µV
MW 520 ... 1740 kHz	< 1.26 mV/m
SW1 5.85 ... 6.275 MHz	< 12.6 µV
SW2 7.00 ... 7.51 MHz	< 12.6 µV
SW3 9.44 ... 9.965 MHz	< 12.6 µV
SW4 11.57 ... 12.12 MHz	< 12.6 µV
SW5 13.52 ... 13.99 MHz	< 12.6 µV
SW6 15.00 ... 15.73 MHz	< 15.8 µV
SW7 17.42 ... 18.03 MHz	< 15.8 µV
SW8 21.35 ... 22.05 MHz	< 15.8 µV

Distortion	Frequency response	S/N ratio
FM (1 mV) < 4 %	(-3 db) < 250 ... 6300 Hz >	> 45 db
MW (5 mV) < 5 %	(-6 db) < 250 ... 2000 Hz >	> 30 db
SW1 ... SW8 (100 µV)	—	> 30 db

Amplifier

Power output (THD = 10 %): > 120 mW
Max. power output: 180 mW
Earphone (mode): 32 Ω / 2 × 10 mW

Gesamtblockschaltplan / Main block diagram

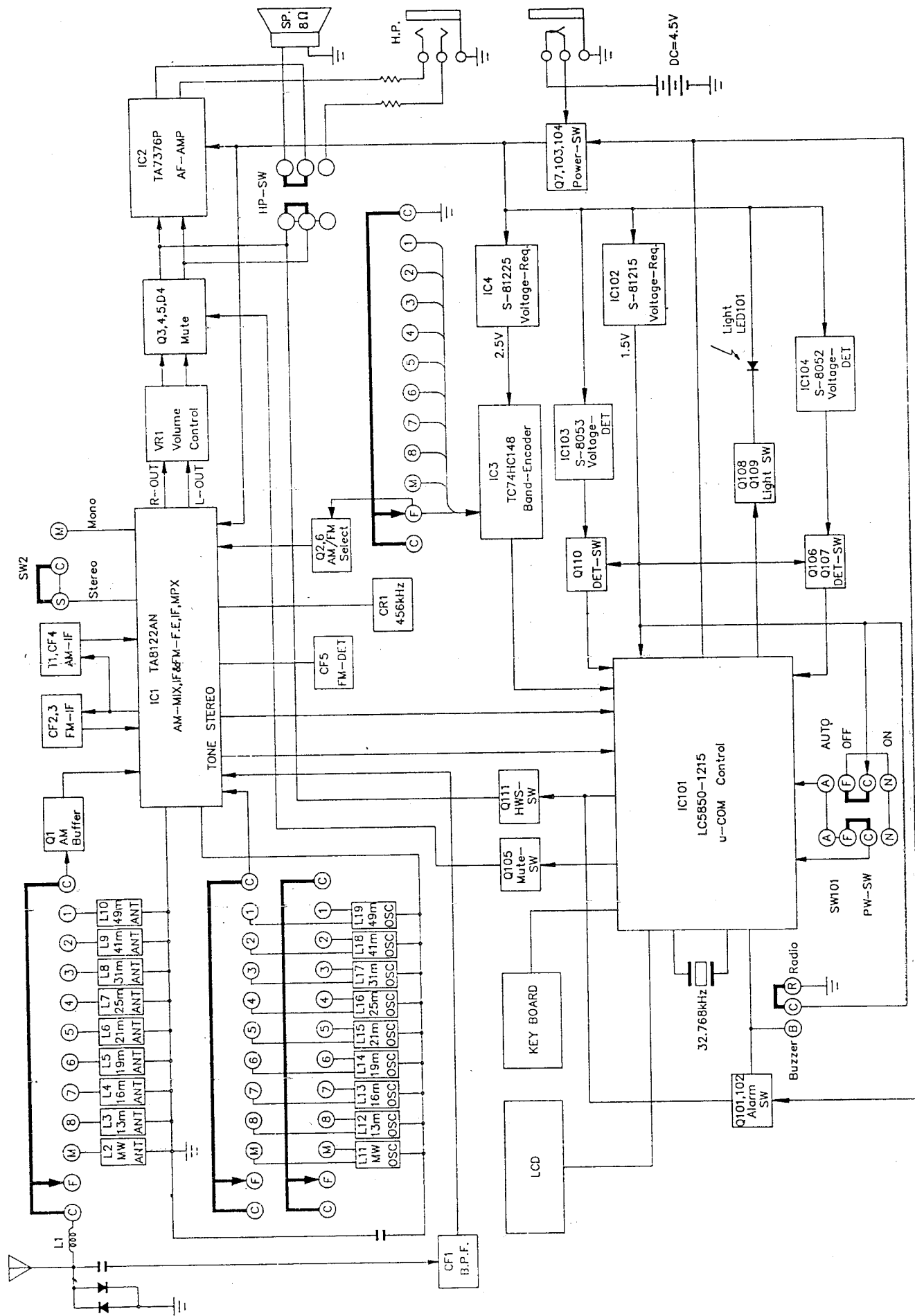

Einbau - Ausbau Assembly - Disassembly

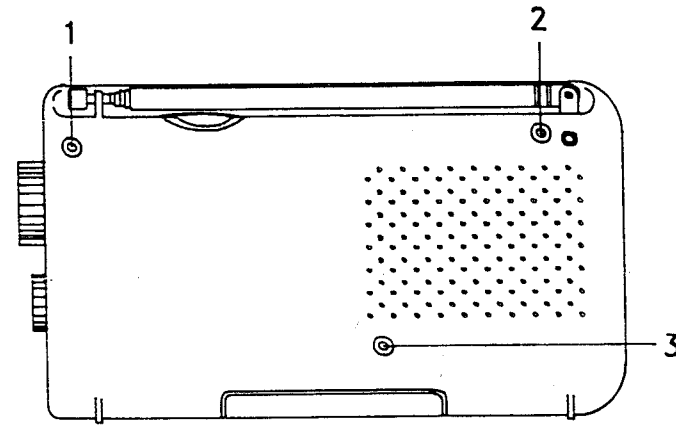

Rückwand / Rear cabinet

Drei Schrauben berücksichtigen. /
Have regard to 3 screws.

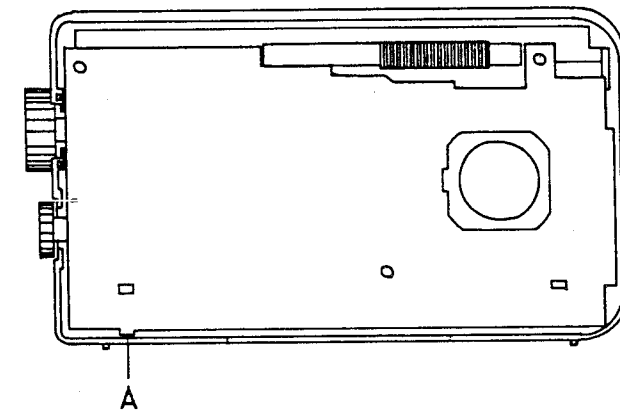

Mittelchassis / Middle chassis assy

Mittelchassis und Gerätefront über „A“ trennen. /
Separate middle chassis assy and front cabinet.

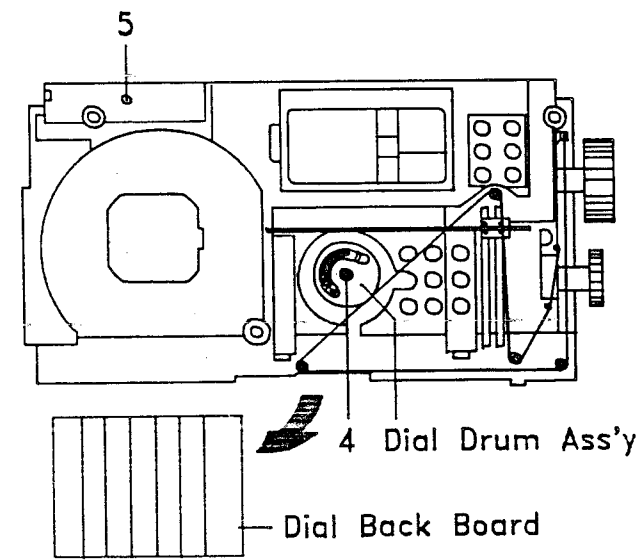

Tunerplatine, PLL-Platine, Schalterplatine (5),
Seilzug (4), Skala /

Tuner p.c.b., PLL-p.c.b., Switch p.c.b. (5),
dial cord assy, dial back board

ABGLEICH

Schritt	Funktion	Vorbereitung	Signaleingang	Einstell- element	Meßwert
1	Uhrentakt, Referenzfrequenz	Die Ein-/Ausschalttaste (Power) ausschalten. Frequenzzähler über 470 kΩ-Widerstand an IC101, Pin 36 und 38 anschließen.	—	VT101	32,768 kHz
2	AM-ZF	Die Ein-/Ausschalttaste (Power) einschalten. Den Wobbelgeneratoreingang in Serie mit 10 µF-Kondensator an TP5 und Masse anschließen. Den Wobbelgeneratorausgang über 0,01 µF-Kondensator an TP3 und Masse anschließen.	Um 460 kHz wobbeln	T1	Maximale Empfindlichkeit bei 460 kHz
3	MW-Eckfrequenzen. Abgleich mehrmals wiederholen	Die Ein-/Ausschalttaste einschalten. Abgleichsender an die Ferritantenne (20W) ankoppeln. Voltmeter (10M) an TP7 und Masse anschließen. Skalenzeiger zur tiefsten Frequenz stellen Skalenzeiger zur höchsten Frequenz stellen	520 kHz/30 %/1 kHz 1740 kHz/30 %/1 kHz	L11 VT3	Max. 1 kHz-Pegel Max. 1 kHz-Pegel
4	MW-Vorselektion. Abgleich mehrmals wiederholen	Skalenzeiger zur tiefsten Frequenz stellen Skalenzeiger zur höchsten Frequenz stellen	520 kHz/30 %/1 kHz 1740 kHz/30 %/1 kHz	L3 VT1	Max. 1 kHz-Pegel Max. 1 kHz-Pegel
5	UKW-Eckfrequenzen. Abgleich mehrmals wiederholen	Die Ein-/Ausschalttaste auf einstellen. Den Abgleichsenderausgang an TP1 und Masse anschließen. Das Voltmeter (10M) an TP7 und Masse anschließen. Skalenzeiger zur tiefsten Frequenz stellen Skalenzeiger zur höchsten Frequenz stellen	87,35 MHz/40 kHz/1 kHz 108,25 MHz/40 kHz/1 kHz	L23 VT5	Max. 1 kHz-Pegel Max. 1 kHz-Pegel
6	UKW-Vorselektion. Abgleich mehrmals wiederholen	Skalenzeiger zur tiefsten Frequenz stellen Skalenzeiger zur höchsten Frequenz stellen	87,35 MHz/40 kHz/1 kHz 108,25 MHz/40 kHz/1 kHz	L22 VT4	Max. 1 kHz-Pegel Max. 1 kHz-Pegel
7	KW-Eckfrequenzen	Die Ein-/Ausschalttaste auf einstellen. Den Abgleichsender über 12 pF-Kondensator an TP1 und Masse anschließen. Das Voltmeter (10M) an TP7 und Masse anschließen. Skalenzeiger zur tiefsten Frequenz stellen Skalenzeiger zur tiefsten Frequenz stellen Skalenzeiger zur tiefsten Frequenz stellen Skalenzeiger zur tiefsten Frequenz stellen Skalenzeiger zur tiefsten Frequenz stellen Skalenzeiger zur tiefsten Frequenz stellen Skalenzeiger zur tiefsten Frequenz stellen Skalenzeiger zur tiefsten Frequenz stellen	5,85 MHz/30 %/1 kHz 7,00 MHz/30 %/1 kHz 9,44 MHz/30 %/1 kHz 11,57 MHz/30 %/1 kHz 13,52 MHz/30 %/1 kHz 15,00 MHz/30 %/1 kHz 17,42 MHz/30 %/1 kHz 21,35 MHz/30 %/1 kHz	L19 L18 L17 L16 L15 L14 L13 L12	Max. 1 kHz-Pegel Max. 1 kHz-Pegel Max. 1 kHz-Pegel Max. 1 kHz-Pegel Max. 1 kHz-Pegel Max. 1 kHz-Pegel Max. 1 kHz-Pegel Max. 1 kHz-Pegel
8	KW-Vorselektion	Skalenzeiger zur tiefsten Frequenz stellen Skalenzeiger zur tiefsten Frequenz stellen Skalenzeiger zur tiefsten Frequenz stellen Skalenzeiger zur tiefsten Frequenz stellen Skalenzeiger zur tiefsten Frequenz stellen Skalenzeiger zur tiefsten Frequenz stellen Skalenzeiger zur tiefsten Frequenz stellen Skalenzeiger zur tiefsten Frequenz stellen	5,85 MHz/30 %/1 kHz 7,00 MHz/30 %/1 kHz 9,44 MHz/30 %/1 kHz 11,57 MHz/30 %/1 kHz 13,52 MHz/30 %/1 kHz 15,00 MHz/30 %/1 kHz 17,42 MHz/30 %/1 kHz 21,35 MHz/30 %/1 kHz	L10 L9 L8 L7 L6 L5 L4 L3	Max. 1 kHz-Pegel Max. 1 kHz-Pegel Max. 1 kHz-Pegel Max. 1 kHz-Pegel Max. 1 kHz-Pegel Max. 1 kHz-Pegel Max. 1 kHz-Pegel Max. 1 kHz-Pegel

ALIGNMENT

Step	Function	Preparation	Signal input	Adjusting element	Indicated value
1	Clock time accuracy	Set power switch to off position. Connect frequency counter via 470 kΩ- resistor to IC101, pin 36 and pin 38.	—	VT101	32.768 kHz
2	AM-IF	Set power switch to on position. Connect sweepgenerator input via 10 µF-capacitor to TP5 and ground. Connect sweepgenerator output via 0.01 µF-capacitor to TP3 and ground.	Wobble at 460 kHz	T1	Max sensitivity when 460 kHz
3	MW-Corner- frequencies. Repeat adjustment several times	Set power switch to on position. Couple RF-generator to bar antenna (20t). Connect voltmeter (10M) to TP7 and ground. Set pointer to lowest frequency Set pointer to highest frequency	520 kHz/30 %/1 kHz 1740 kHz/30 %/1 kHz	L11 VT3	Max. 1 kHz-level Max. 1 kHz-level
4	MW-Tracking. Repeat adjustment several times	Set pointer to lowest frequency Set pointer to highest frequency	520 kHz/30 %/1 kHz 1740 kHz/30 %/1 kHz	L3 VT1	Max. 1 kHz-level Max. 1 kHz-level
5	FM-Corner- frequencies. Repeat adjustment several times	Set power switch to on position. Connect RF-generator to TP1 and ground. Connect voltmeter (10M) to TP7 and ground. Set pointer to lowest frequency Set pointer to highest frequency	87.35 MHz/40 kHz/1 kHz 108.25 MHz/40 kHz/1 kHz	L23 VT5	Max. 1 kHz-level Max. 1 kHz-level
6	FM-Tracking. Repeat adjustment several times	Set pointer to lowest frequency Set pointer to highest frequency	87.35 MHz/40 kHz/1 kHz 108.25 MHz/40 kHz/1 kHz	L22 VT4	Max. 1 kHz-level Max. 1 kHz-level
7	SW-Corner- frequencies	Set power switch to on position. Connect RF-generator via 12 pF- capacitor to TP1 and ground. Connect voltmeter (10M) to TP7 and ground. Set pointer to lowest frequency Set pointer to lowest frequency Set pointer to lowest frequency Set pointer to lowest frequency Set pointer to lowest frequency Set pointer to lowest frequency Set pointer to lowest frequency Set pointer to lowest frequency	5.85 MHz/30 %/1 kHz 7.00 MHz/30 %/1 kHz 9.44 MHz/30 %/1 kHz 11.57 MHz/30 %/1 kHz 13.52 MHz/30 %/1 kHz 15.00 MHz/30 %/1 kHz 17.42 MHz/30 %/1 kHz 21.35 MHz/30 %/1 kHz	L19 L18 L17 L16 L15 L14 L13 L12	Max. 1 kHz-level Max. 1 kHz-level Max. 1 kHz-level Max. 1 kHz-level Max. 1 kHz-level Max. 1 kHz-level Max. 1 kHz-level Max. 1 kHz-level
8	SW-Tracking	Set pointer to lowest frequency Set pointer to lowest frequency Set pointer to lowest frequency Set pointer to lowest frequency Set pointer to lowest frequency Set pointer to lowest frequency Set pointer to lowest frequency Set pointer to lowest frequency	5.85 MHz/30 %/1 kHz 7.00 MHz/30 %/1 kHz 9.44 MHz/30 %/1 kHz 11.57 MHz/30 %/1 kHz 13.52 MHz/30 %/1 kHz 15.00 MHz/30 %/1 kHz 17.42 MHz/30 %/1 kHz 21.35 MHz/30 %/1 kHz	L10 L9 L8 L7 L6 L5 L4 L3	Max. 1 kHz-level Max. 1 kHz-level Max. 1 kHz-level Max. 1 kHz-level Max. 1 kHz-level Max. 1 kHz-level Max. 1 kHz-level Max. 1 kHz-level

ALIGNMENT

Step	Function	Preparation	Signal input	Adjusting element	Indicated value
1	Clock time accuracy	Set power switch to off position. Connect frequency counter via 470 kΩ-resistor to IC101, pin 36 and pin 38.	-	VT101	32.768 kHz
2	AM-IF	Set power switch to on position. Connect sweepgenerator input via 10 μF-capacitor to TP5 and ground. Connect sweepgenerator output via 0.01 μF-capacitor to TP3 and ground.	Wobble at 460 kHz	T1	Max sensitivity when 460 kHz
3	MW-Corner-frequencies. Repeat adjustment several times	Set power switch to on position. Couple RF-generator to bar antenna (20t). Connect voltmeter (10M) to TP7 and ground. Set pointer to lowest frequency Set pointer to highest frequency	520 kHz/30%/1 kHz 1740 kHz/30%/1 kHz	L11 VT3	Max. 1 kHz-level Max. 1 kHz-level
4	MW-Tracking. Repeat adjustment several times	Set pointer to lowest frequency Set pointer to highest frequency	520 kHz/30%/1 kHz 1740 kHz/30%/1 kHz	L3 VT1	Max. 1 kHz-level Max. 1 kHz-level
5	FM-Corner-frequencies. Repeat adjustment several times	Set power switch to on position. Connect RF-generator to TP1 and ground. Connect voltmeter (10M) to TP7 and ground. Set pointer to lowest frequency Set pointer to highest frequency	87.35 MHz/40 kHz/1 kHz 108.25 MHz/40 kHz/1 kHz	L23 VT5	Max. 1 kHz-level Max. 1 kHz-level
6	FM-Tracking. Repeat adjustment several times	Set pointer to lowest frequency Set pointer to highest frequency	87.35 MHz/40 kHz/1 kHz 108.25 MHz/40 kHz/1 kHz	L22 VT4	Max. 1 kHz-level Max. 1 kHz-level
7	SW-Corner-frequencies	Set power switch to on position. Connect RF-generator via 12 pF-capacitor to TP1 and ground. Connect voltmeter (10M) to TP7 and ground. Set pointer to lowest frequency	5.85 MHz/30%/1 kHz 7.00 MHz/30%/1 kHz 9.44 MHz/30%/1 kHz 11.57 MHz/30%/1 kHz 13.52 MHz/30%/1 kHz 15.00 MHz/30%/1 kHz 17.42 MHz/30%/1 kHz 21.35 MHz/30%/1 kHz	L19 L18 L17 L16 L15 L14 L13 L12	Max. 1 kHz-level Max. 1 kHz-level Max. 1 kHz-level Max. 1 kHz-level Max. 1 kHz-level Max. 1 kHz-level Max. 1 kHz-level Max. 1 kHz-level
8	SW-Tracking	Set pointer to lowest frequency	5.85 MHz/30%/1 kHz 7.00 MHz/30%/1 kHz 9.44 MHz/30%/1 kHz 11.57 MHz/30%/1 kHz 13.52 MHz/30%/1 kHz 15.00 MHz/30%/1 kHz 17.42 MHz/30%/1 kHz 21.35 MHz/30%/1 kHz	L10 L9 L8 L7 L6 L5 L4 L3	Max. 1 kHz-level Max. 1 kHz-level Max. 1 kHz-level Max. 1 kHz-level Max. 1 kHz-level Max. 1 kHz-level Max. 1 kHz-level Max. 1 kHz-level

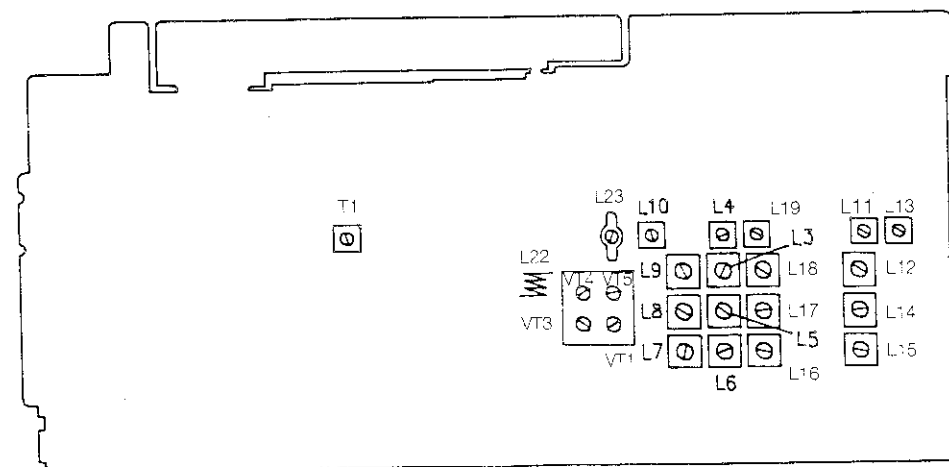
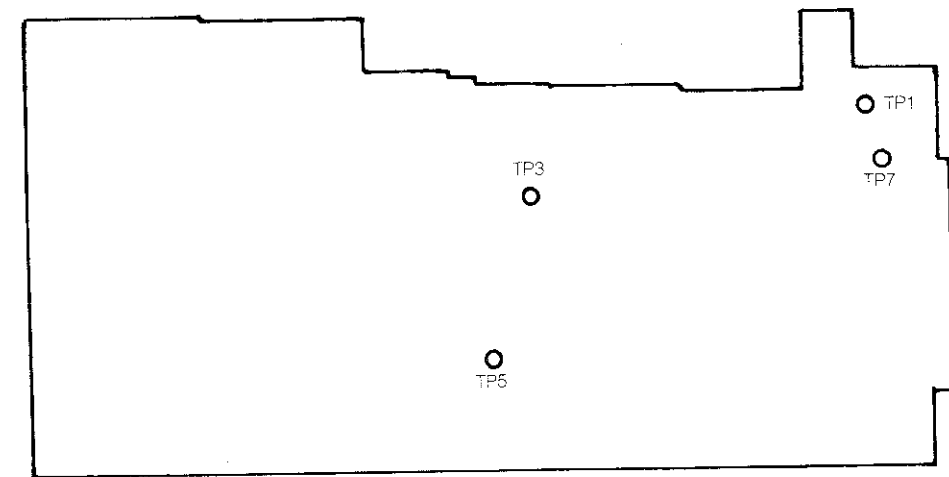
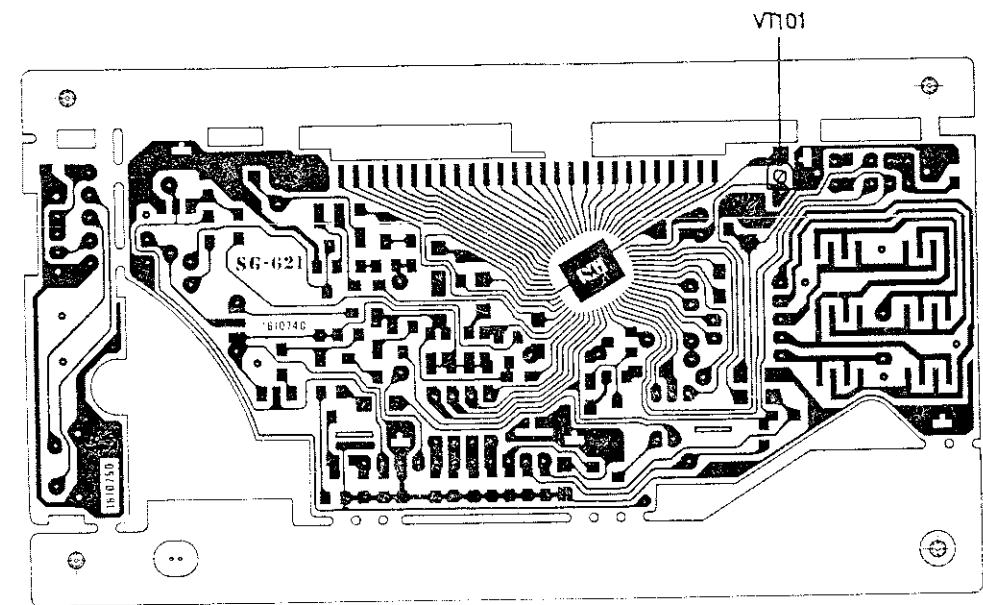
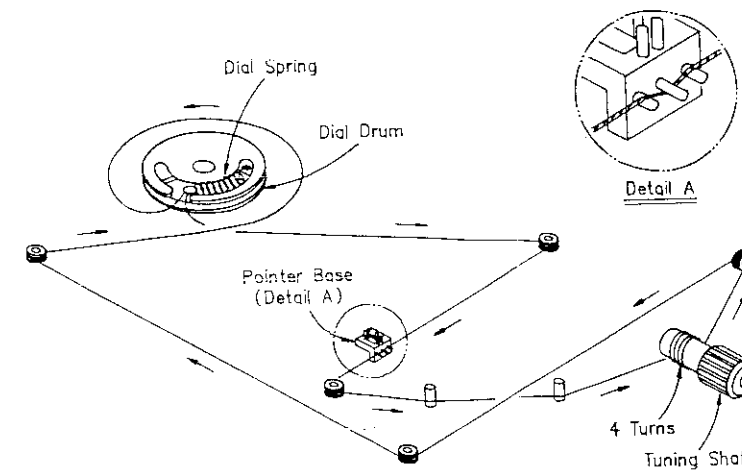

Schalterplatte
Switch p.c.b.

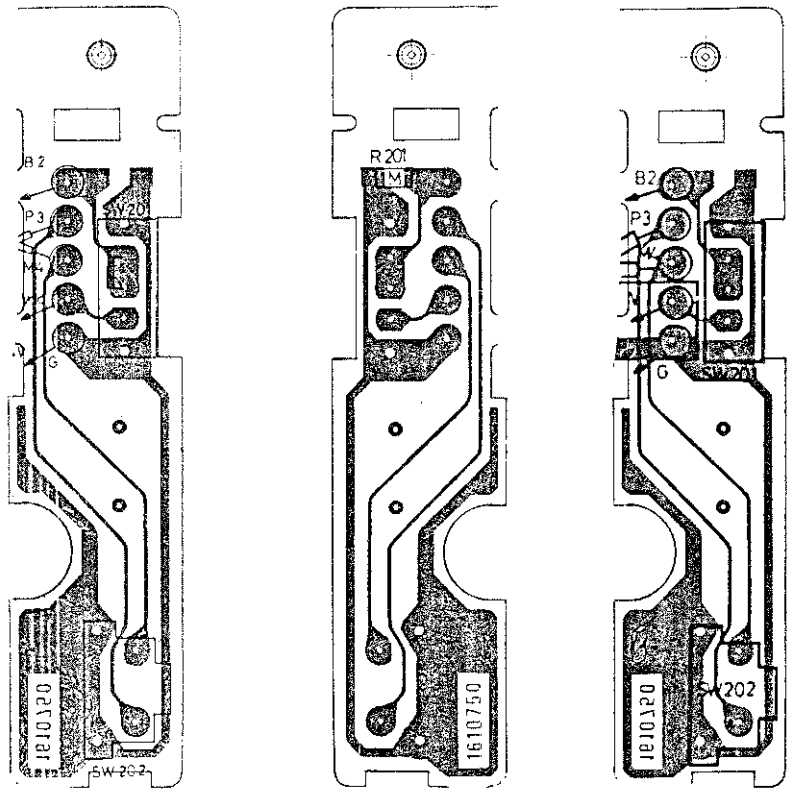

PCB-C

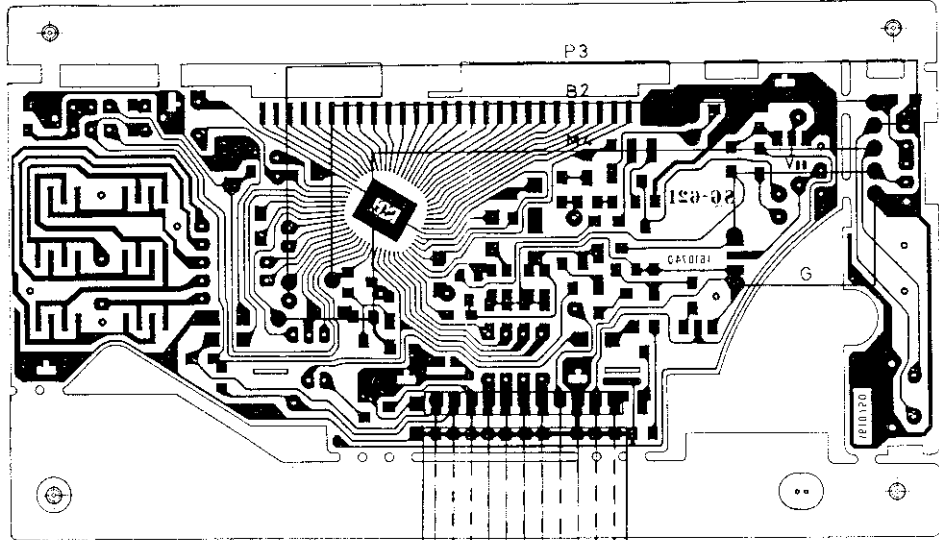

PCB-A

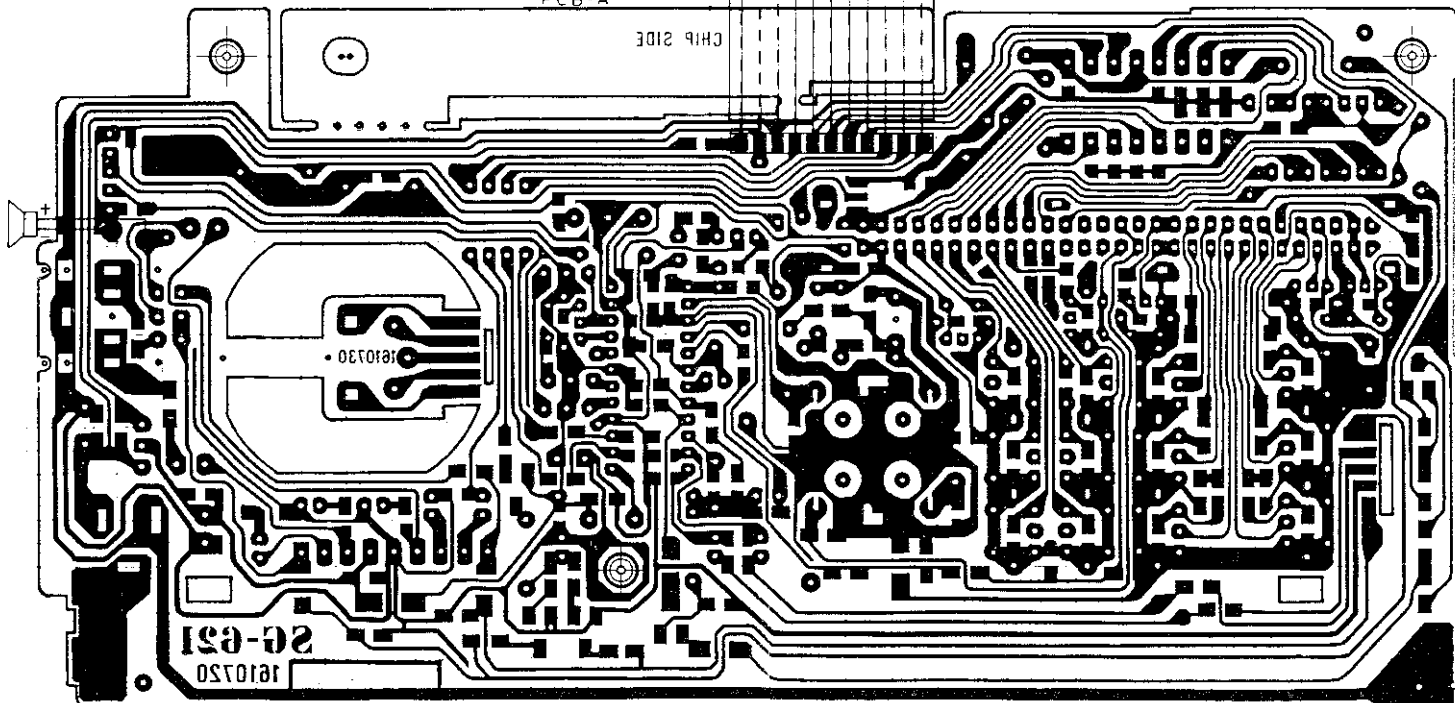

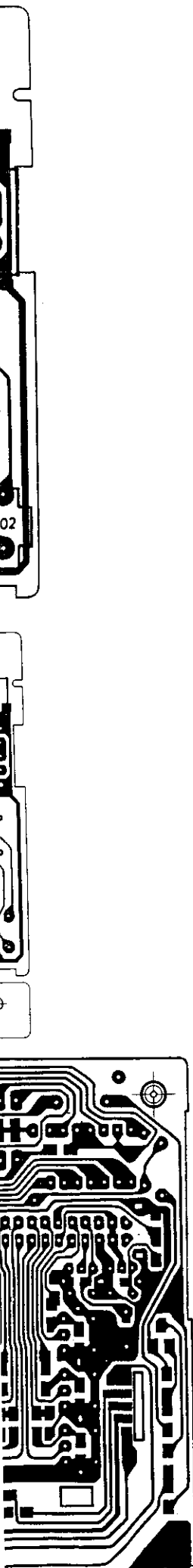
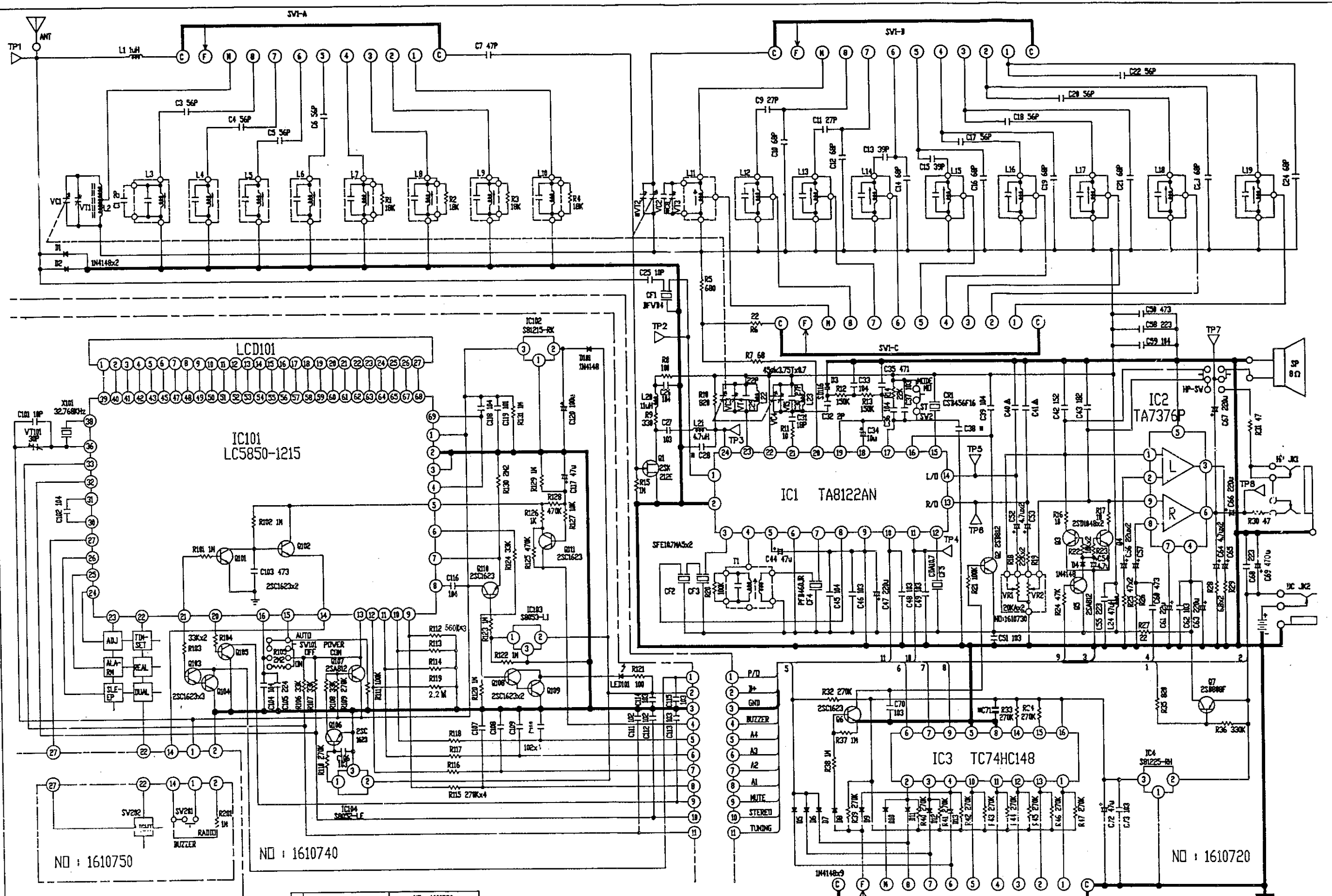

NO : 1610750

NO : 1610740

NO : 1610720

NO : 1610740		NO : 1610720	
END OF NO	BLANK	END OF NO	BLANK
R	131	47	
C	120	73	28,28,36,71
Q	111	7	
L		24	
VT	101	5	2

A

	F.T.Z.	F.C.C.
C40	123	183
C41	123	183

IC1-TA8122AN/AF

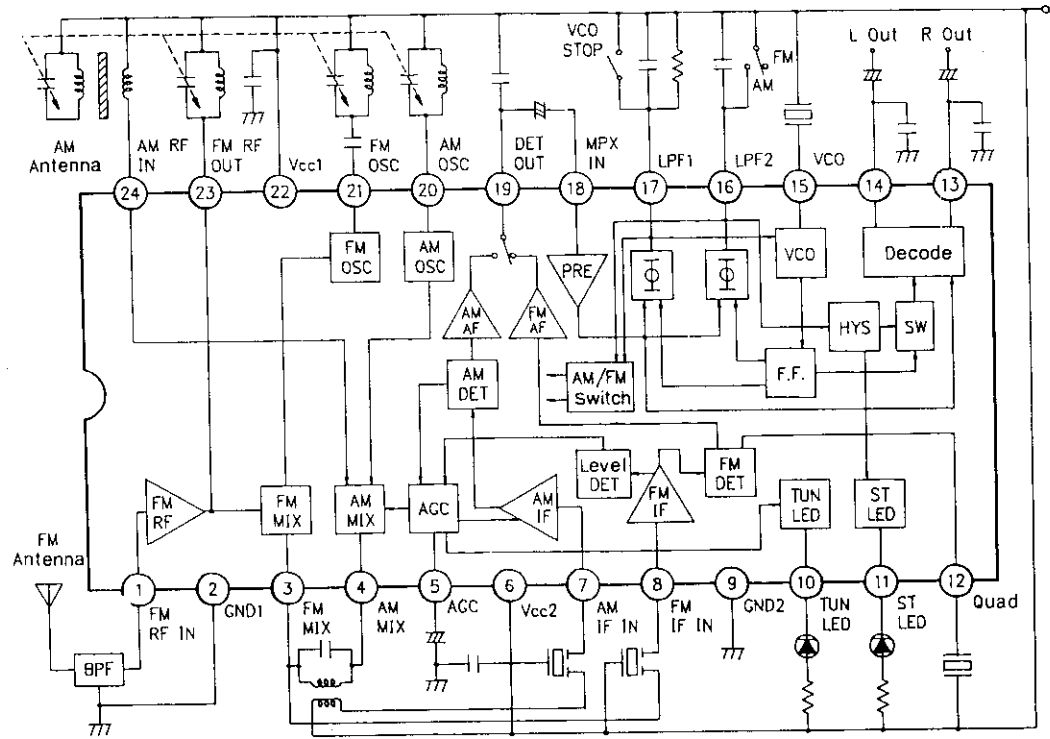

Logic Diagram

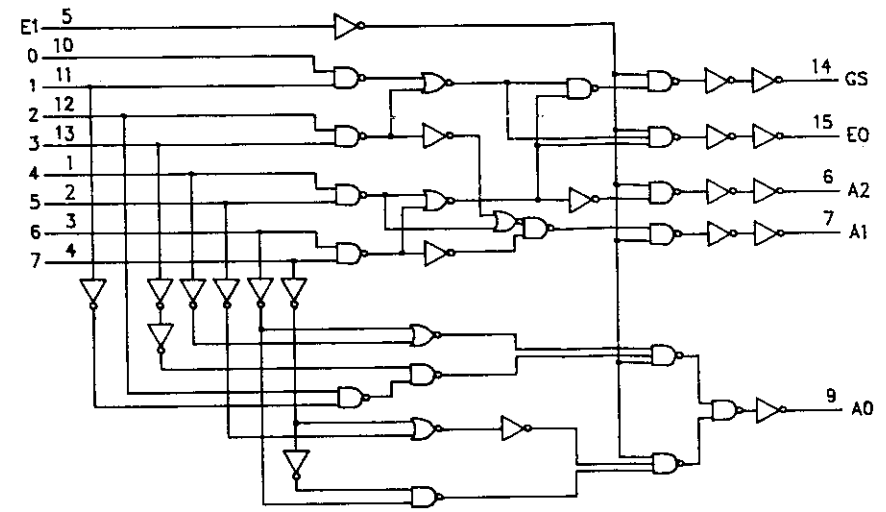

Segment
For LCD
Display
1.5 Volt
1/2 Bias
1/3 Duty

IC2-TA7376P

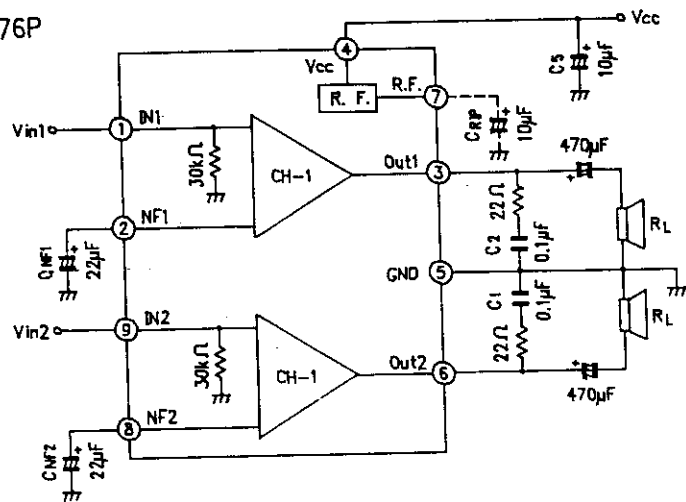

IC3-TC74HC148

Truth Table / Wahrheitstabelle

X: Don't Care

		INPUTS								OUTPUTS				
E1	0	1	2	3	4	5	6	7	A2	A1	A0	GS	E0	
H	X	X	X	X	X	X	X	X	H	H	H	H	H	
L	H	H	H	H	H	H	H	H	H	H	H	H	L	
L	X	X	X	X	X	X	X	X	L	L	L	L	H	
L	X	X	X	X	X	X	X	L	H	L	L	H	L	
L	X	X	X	X	L	H	H	H	L	H	L	L	H	
L	X	X	X	X	L	H	H	H	H	L	L	L	H	
L	X	X	X	L	H	H	H	H	H	L	L	L	H	
L	X	X	L	H	H	H	H	H	H	L	L	L	H	
L	L	H	H	H	H	H	H	H	H	H	H	L	H	
L	L	H	H	H	H	H	H	H	H	H	H	L	H	

Pin Assignment

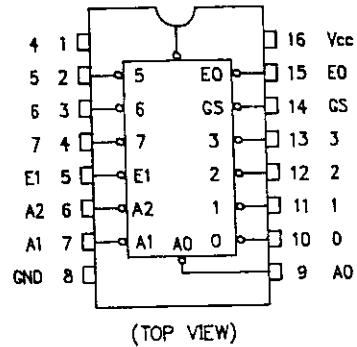

IC4, IC102-S-812 Series

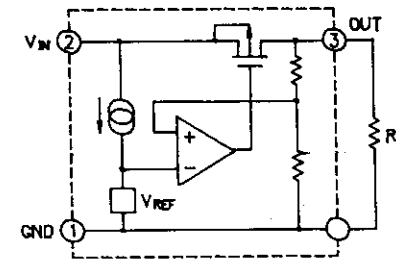

IC103, IC104-S-805 Series

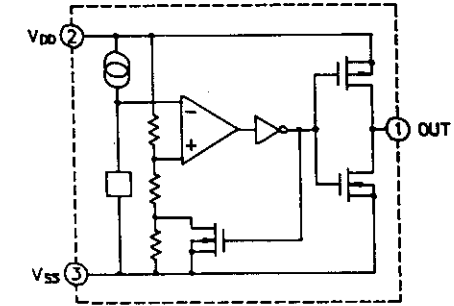

IC101-LC5850-1215

Equivalent Circuit Block Diagram

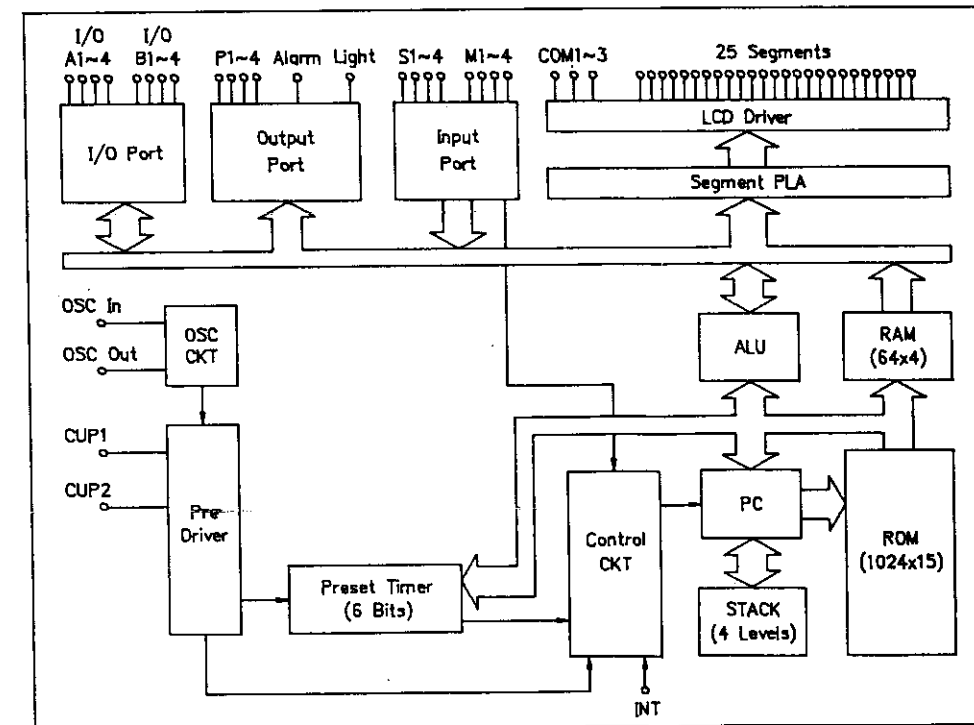

LCD
PIN NO
1
2
3
4
5
6
7
8
9
10
11
12
13
14
15
16
17
18
19
20

Logic Diagram

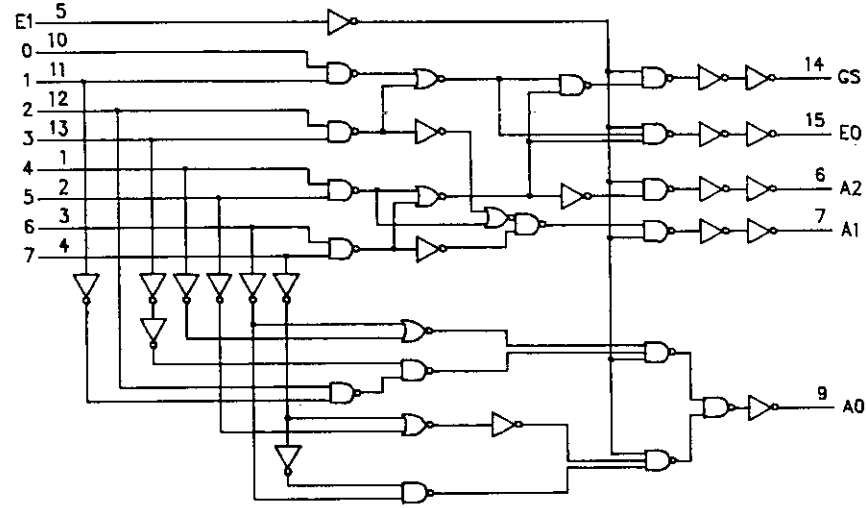

IC4, IC102-S-812 Series

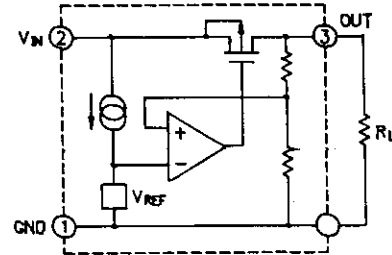

IC103, IC104-S-805 Series

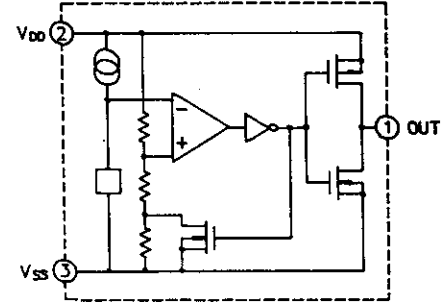

IC101-LC5850-1215

Equivalent Circuit Block Diagram

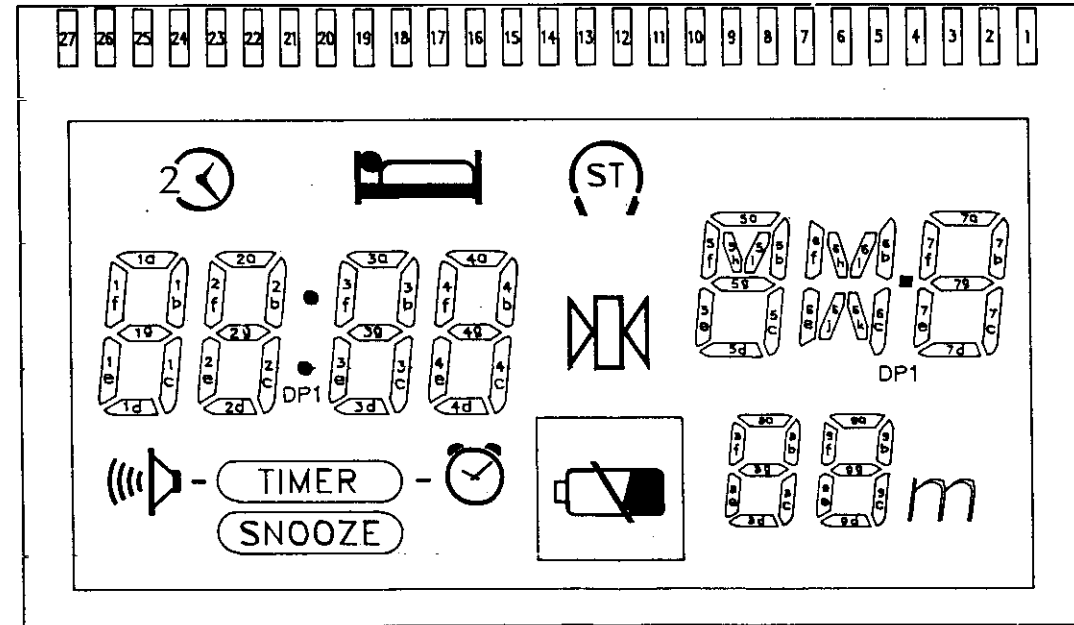
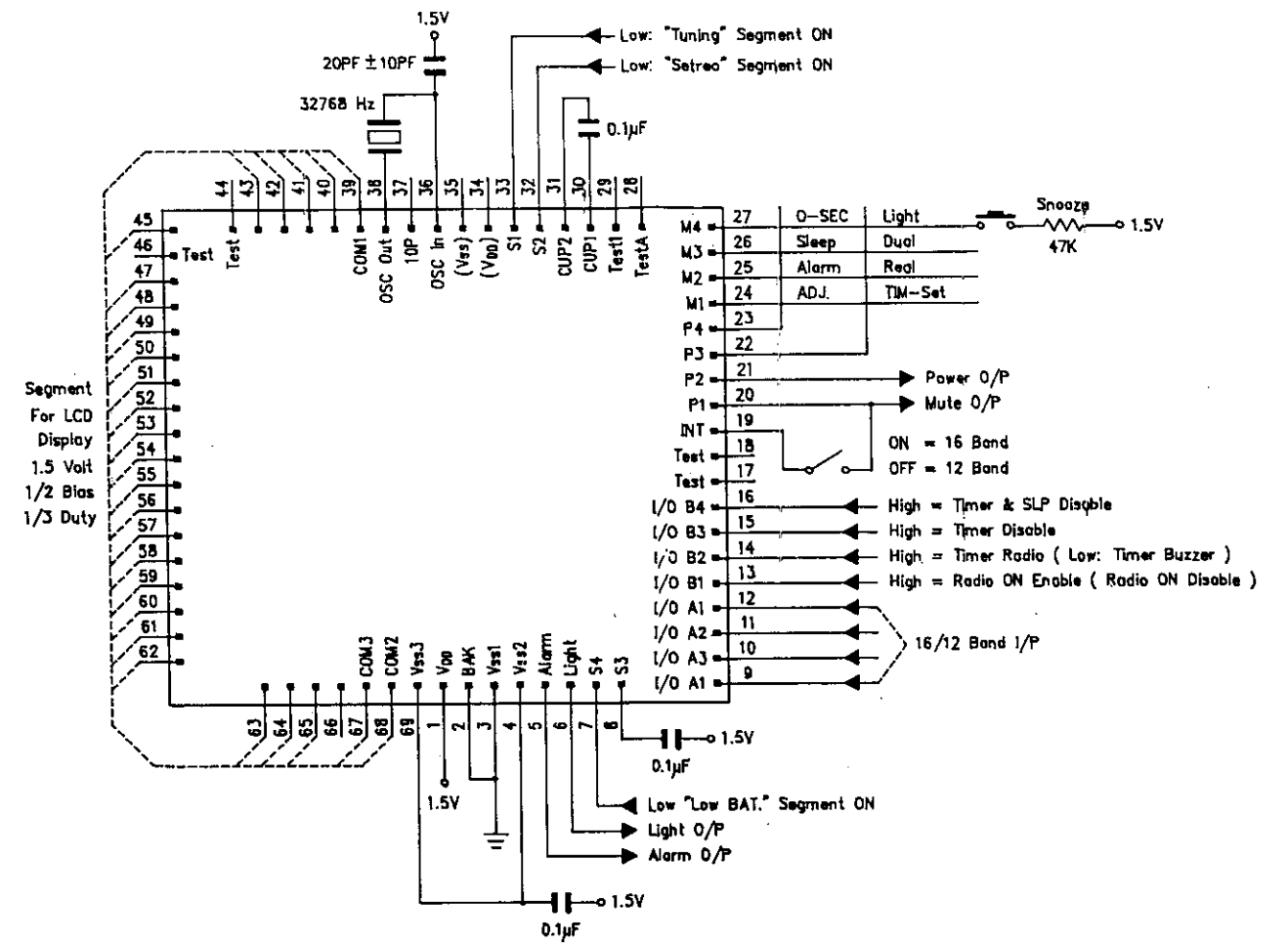
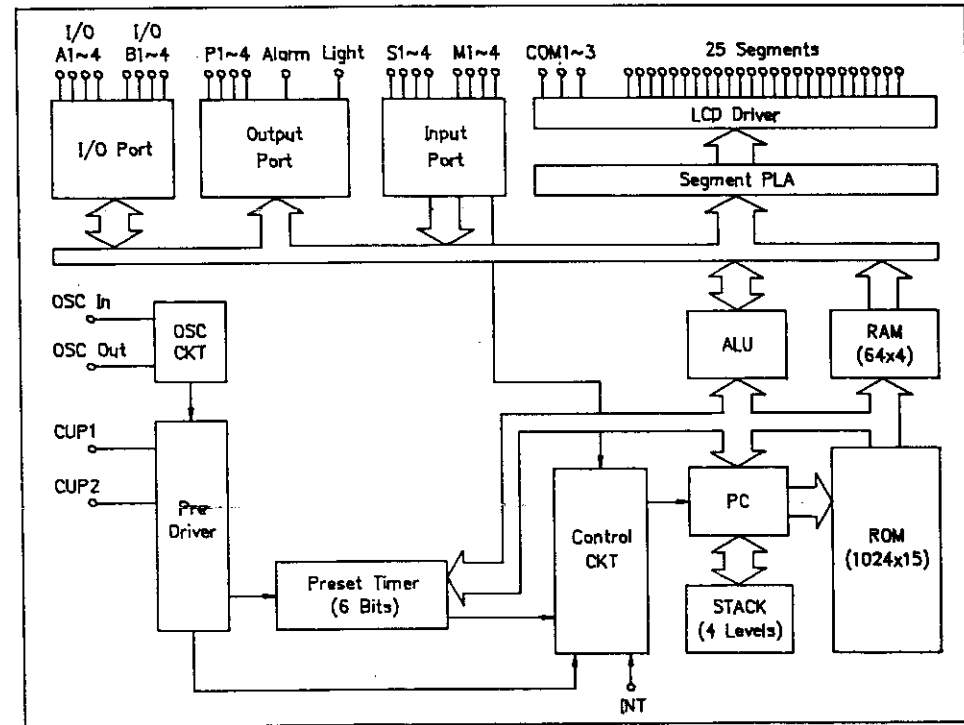

LCD PIN NO	SEGMENT	IC101 PIN NO
1	COM1	39
2	m	40
3	9c	41
4	9d	42
5	8c	43
6	8d	45
7	7c	47
8	7d	48
9	7e	49
10	5d	50
11	5c	51
12	5e	52
13	SNOOZE	53
14	DP1	54
15	4c	55
16	4d	56
17	4e	57
18	3c	58
19	3d	59
20	2c	60

LCD PIN NO	SEGMENT	IC101 PIN NO
21	2d	61
22	2e	62
23	1c	63
24	1d	64
25	SNOOZE	65
26	COM2	67
27	COM3	68