

EMS VOCODER
2000
SERVICE MANUAL

Information from

EMS

EMS VOCODER
2000
SERVICE MANUAL

Written by Tim Orr - May 1977

Trendeal Veian Barn
Ladock
Truro
Cornwall TR2 4NW
☎ St. Austell
(0726) 883265



INTRODUCTION

The Vocoder 2000 is a signal processing device, which takes two input signals and produces one output. These two signals are known as the 'speech' and the 'excitation'. The output from the Vocoder is a signal which contains a proportion of the harmonic structure of the excitation and the formant structure (the articulation) of the speech. Thus it is possible to make normally inarticulate sounds speak. For instance, if you were to take speech and an organ, it would be possible to make a 'talking organ'.

The heart of the Vocoder is the analysing and synthesizing filter bank. The speech is analysed into 16 frequency bands which cover the audio spectrum. The time varying energy levels in each channel is extracted by an envelope follower. This is in fact a real time spectrum analysis of the speech. Another signal, the excitation is introduced into the Vocoder.

This is the signal that we will make talk. The excitation signal is also analysed into 16 frequency bands throughout the audio spectrum. However, the signal that is presented to each band is multiplied by a control voltage, which is the envelope from the speech channels. Thus the time varying spectrum of the speech is imposed upon the excitation signal; that is the excitation is filtered in a way entirely prescribed by the speech signal.

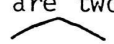
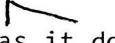
The speech and the excitation signals are connected via $\frac{1}{4}$ " mono jack sockets to the input amplifiers. The signal level is adjusted and given a pre-emphasis, a top lift. A switch connects a VU meter to either the speech or the excitation signal. A device called a voiced/unvoiced detector looks at the speech signal and decides whether or not the speech is unvoiced ('s' sounds) or voiced (sounds derived from vocal chord vibrations). These voiced/unvoiced decisions can be used to turn on or off the machine's internal oscillator and noise source. Also, the unvoiced decision can be used to alter the external excitation signal so that it becomes more 'S' like. This is done by operating the 'S' generator switch. The Vocoder 2000 has two internal excitation sources, the noise source and the oscillator. The noise source is generated by zener diode and can be used continuously, or gated on by the unvoiced decisions or it can be switched off so that it has no effect. The oscillator produces a pulse waveform which can also be used continuously or gated ON by the voiced decision or it can be switched off. Also the pitch of the oscillator can be manually set as well as the option of being varied by a control voltage generated by the filter bank analysis. The slew freeze section controls the synthesis section of the filter bank. It is possible to freeze or to slew limit the control voltages inside the filter and this will of course have an effect on the Vocoder's output. When frozen, the formant structure remains fixed. When heavily slewed, the output sounds very reverberent. This is because information in the filter bank is time smeared. There are two possible types of time smearing that are available, symmetrical  and asymmetrical . The symmetrical option takes as long for a sound to build up as it does to decay, but the asymmetrical gets loaded with a sound structure immediately and then it slowly decays.

When you are making a piece of orchestral music talk, the amplitude dynamics of the speech will be imposed upon the output. Thus there will be lots of big gaps in the Vocoder output which might not be very desirable. To overcome

Continued/.....

this problem we use a device called a pause stuffer. This fills in the silences by fading up the music signal, immediately fading it down when the Vocoder output reappears. Speech or excitation can be used to 'stuff' the pauses and there is a choice of fade in times. The output mixer is used to select either the Vocoder output or the speech or external excitation signal. It is also possible to control any of these signals with an external swell pedal.

COMPARATOR SIGNAL. SAME AS A11, pin 1. THIS IS ONLY TRUE WHEN THE SIGNAL F VUV IS PRESENT.

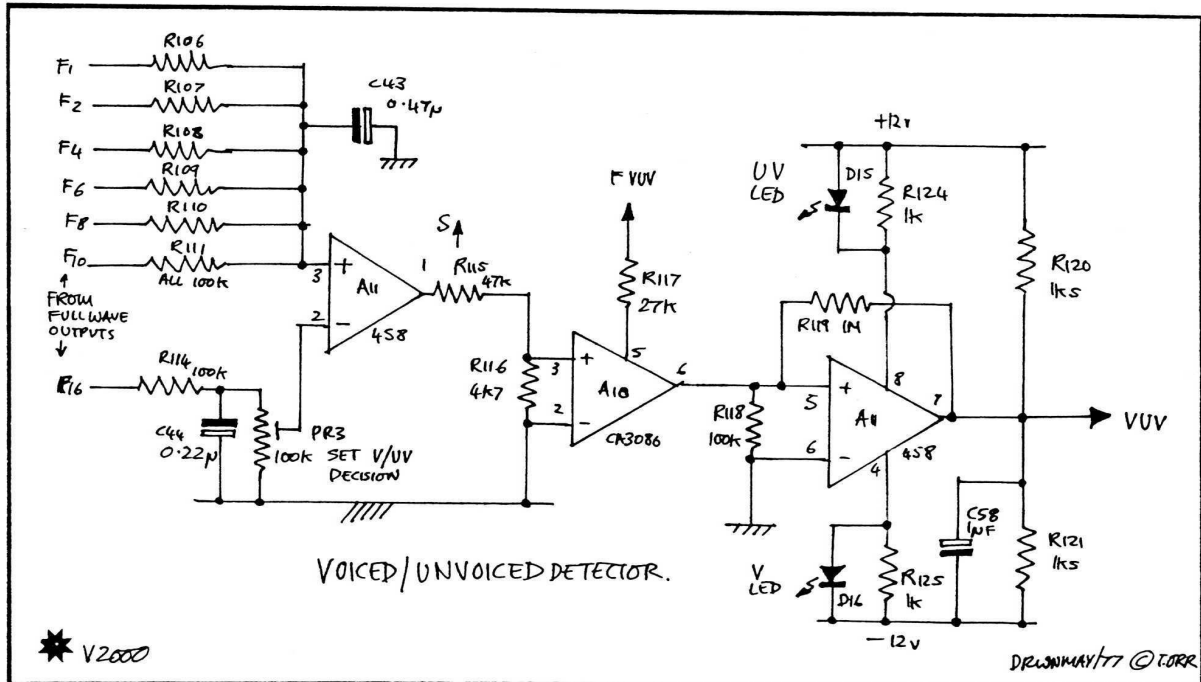
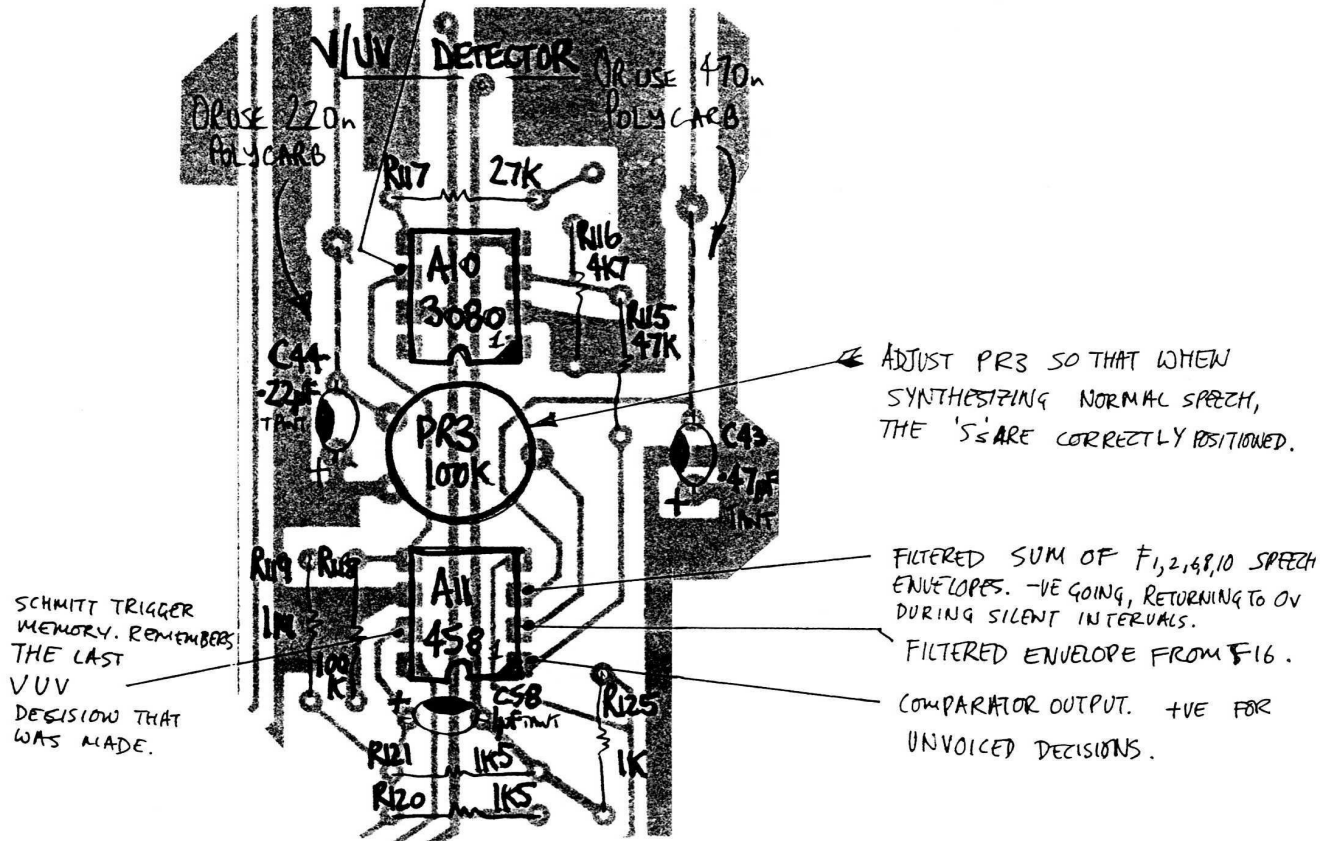

YCA →
ANY DUAL
TRANSISTOR
(NPN) WILL
DO.

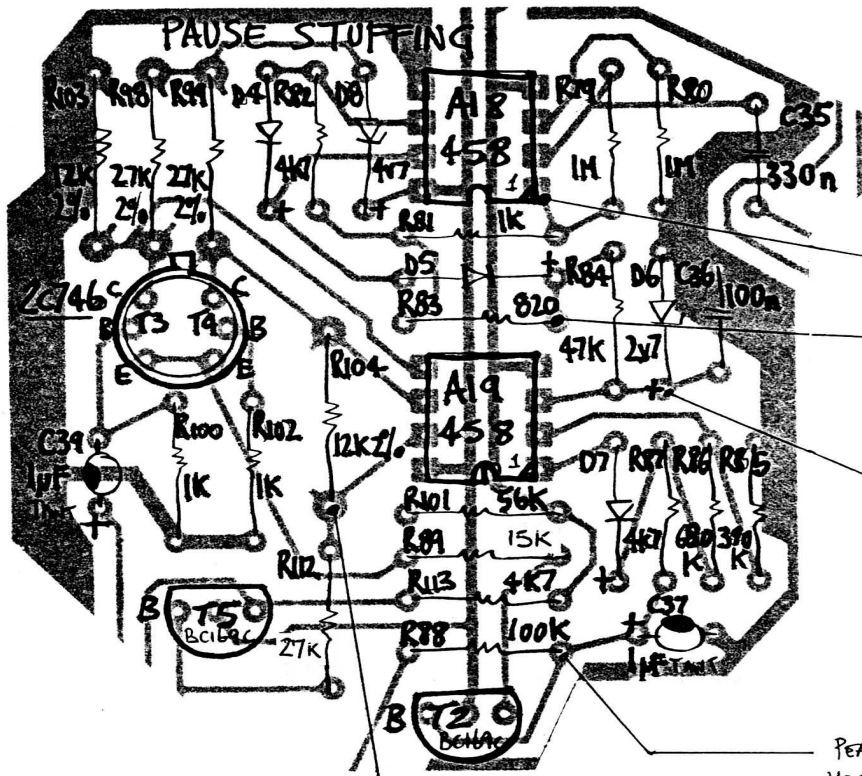

FILTER BANK OUTPUT X100 GAIN.

POSITIVE GAIN, FULL WAVE RECTIFIED
VERSION OF THE FILTERBANK
OUTPUT SIGNAL.

LOW PASS FILTERED SIGNAL OF
ABOVE. LIMITED TO +2.7V.

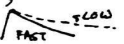
PEAK VOLTAGE FOLLOWER. FOLLOWS
VOCODER SIGNAL WITH A CHOICE
OF RELEASE TIMES,
SELECTED BY SW13. 

YCA OUTPUT. THE SPEECH OR
THE EXCITATION SIGNAL IS
CONTROLLED IN LEVEL BY THE
ENVELOPE OF THE VOCODER.

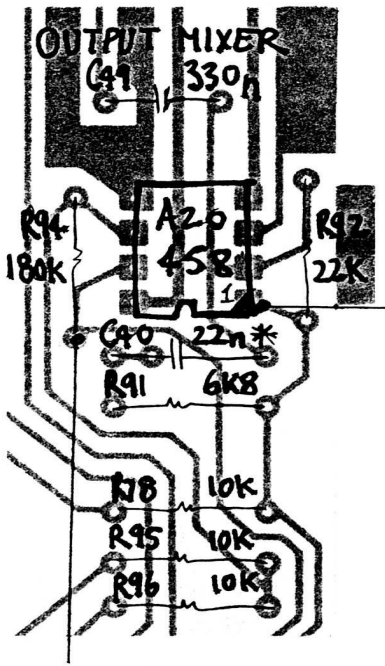

MIXED OUTPUT OF THE FILTERBANK, WITH
A TREBLE CUT.

VOCODER OUTPUT. VARIOUS OUTPUTS INCLUDE, SPEECH, EXTERNAL EXCITATION, VOCODER,
PAUSE STUFFED AND SWELLED OUTPUTS.

★ Y2000

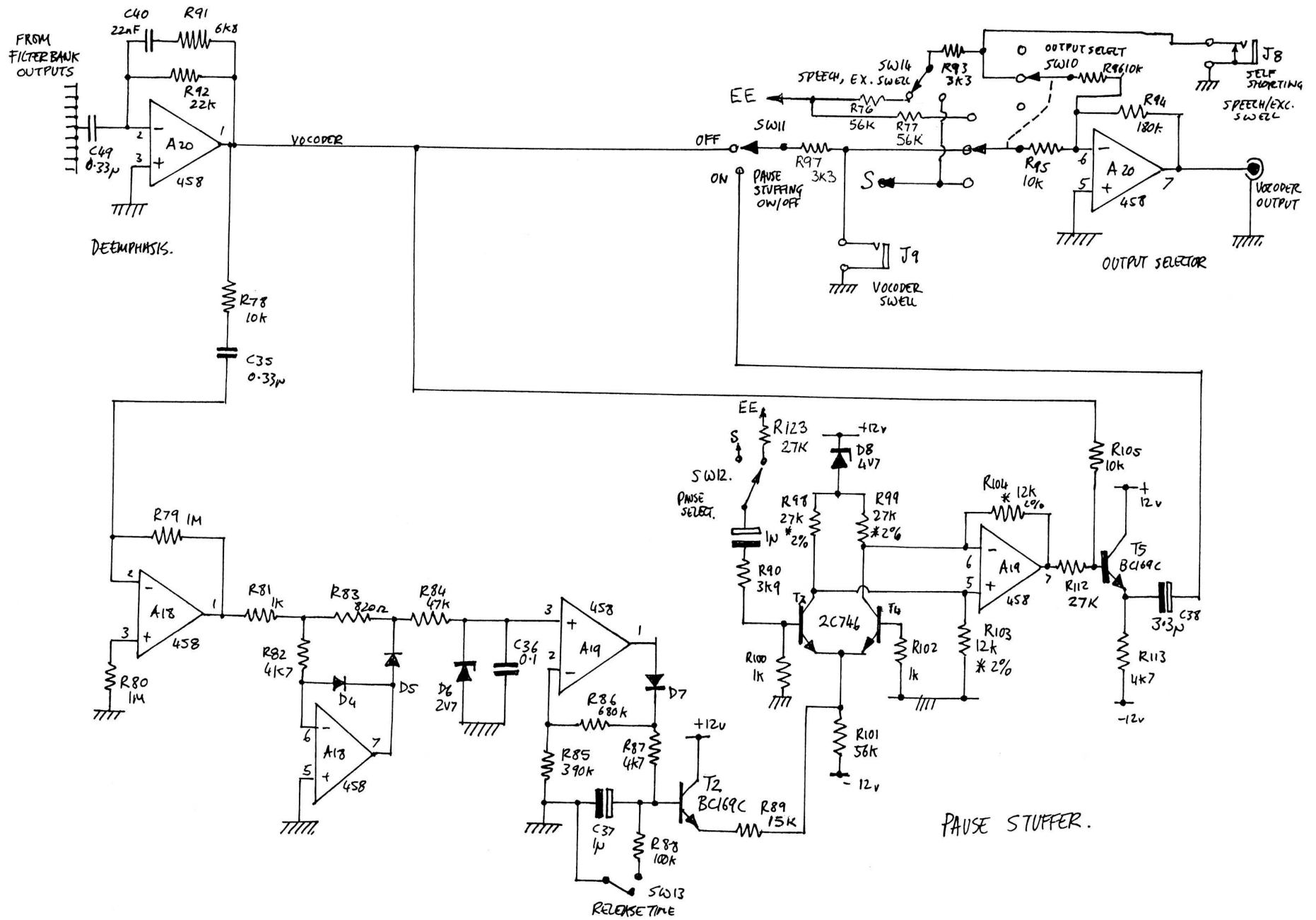

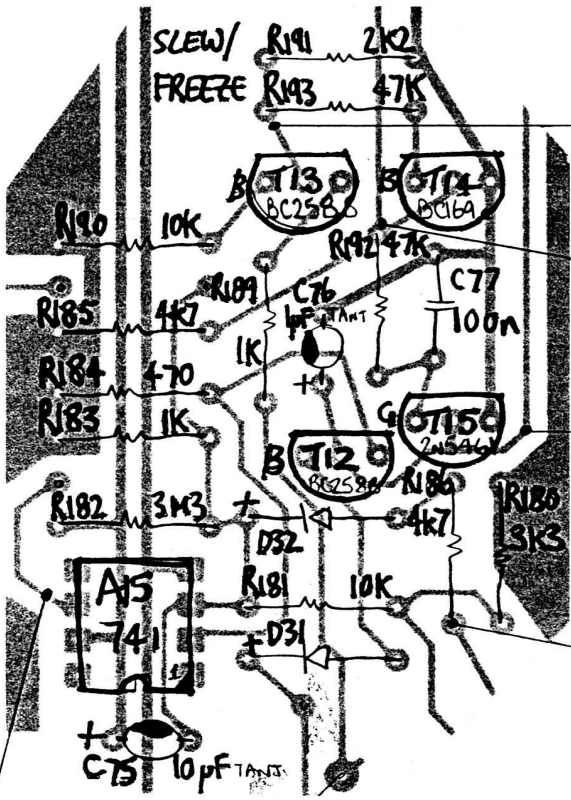

'F' NOT FROZEN \equiv -12V.
 FROZEN \equiv -4V \rightarrow -1V

'F VOY' NOT FROZEN \equiv 0V
 FROZEN \equiv -12V

SHORTED TO THE -VE RAIL WHEN FROZEN.

TO FREEZE SWITCH SWB . FROZEN \equiv +12V

USUALLY -VE.
 +VE WHEN FROZEN.

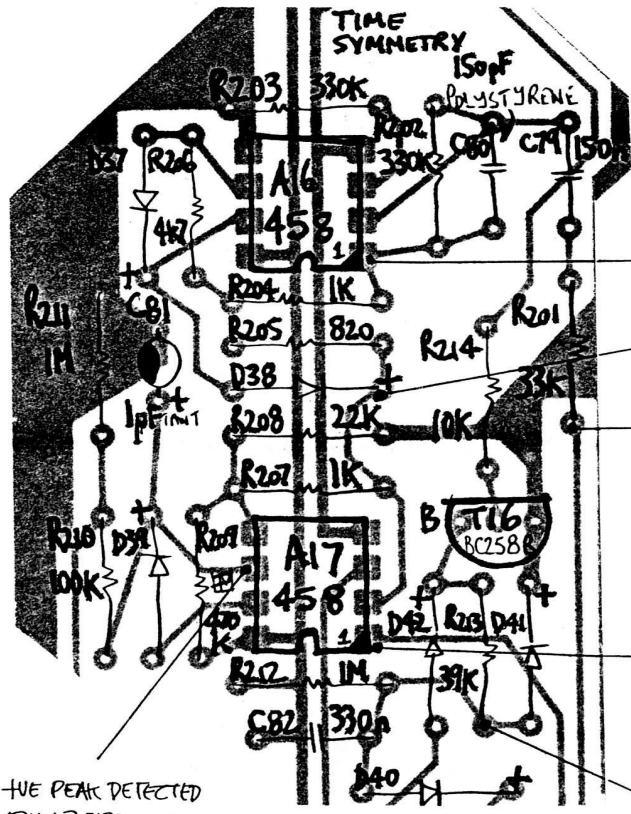

SPEECH SIGNAL X10 GAIN.

FULL WAVE (+VE GOING) RECTIFIED
 SPEECH SIGNAL.

SPEECH SIGNAL S.

COMPARATOR OUTPUT. +10V
 -10V
 -VE GOING PULSES
 WHEN SPEECH IS LOUD.

+VE PEAK DETECTED
 ENVELOPE OF
 THE SPEECH SIGNAL.

MODIFIED COMPARATOR OUTPUT
 SELECTED BY SW 9, TIME SYM. 0V
 -VE

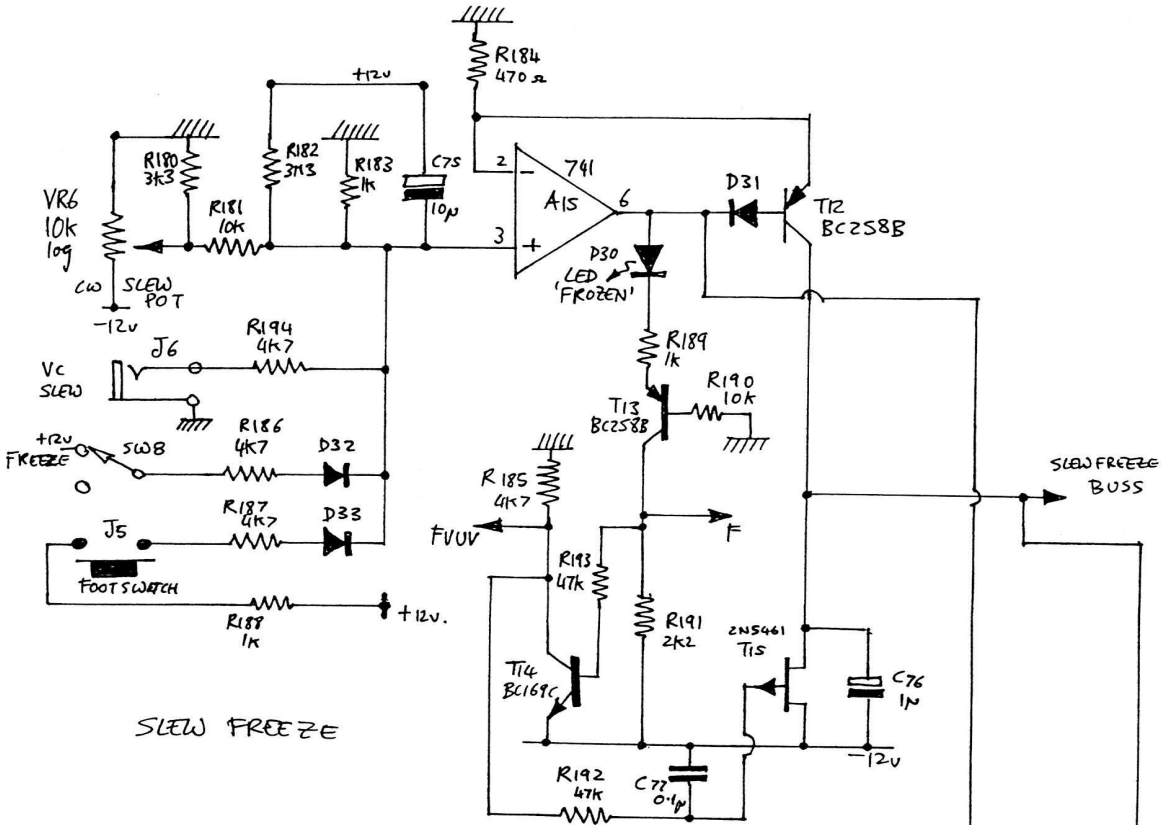

SLEW FREEZE

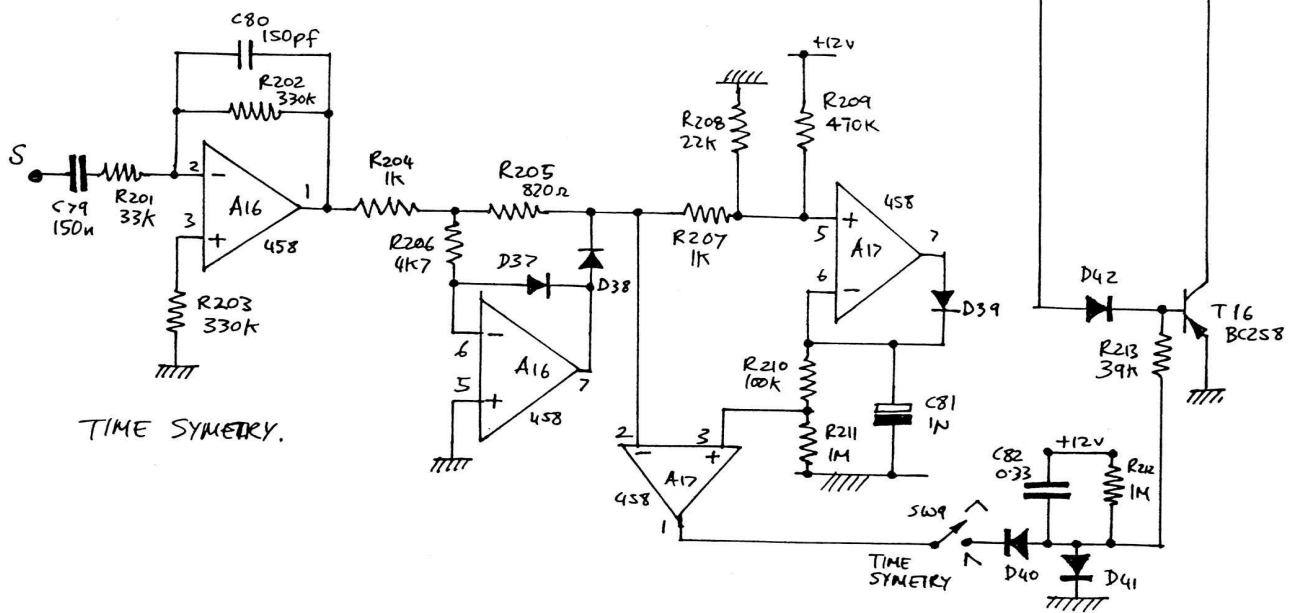

TIME SYMETRY.

DRAWN MAY 77 © T.D.P.R

★ V2000

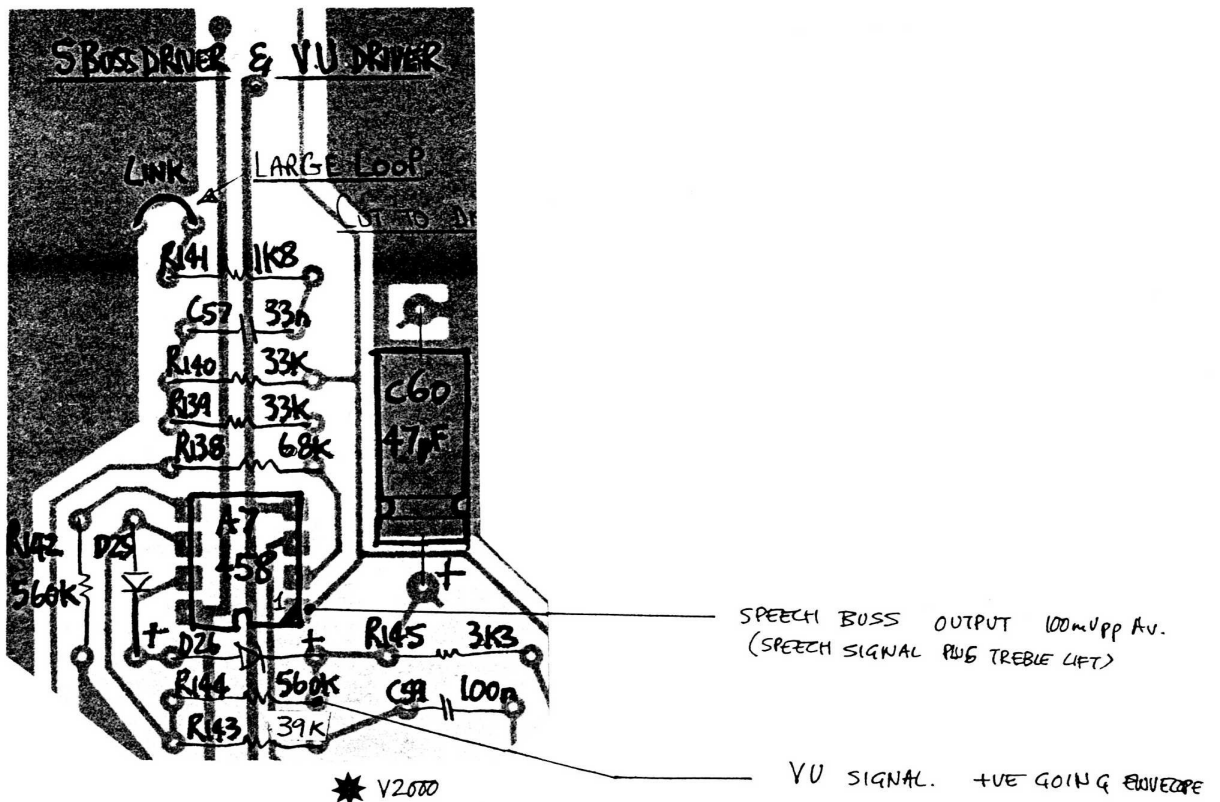
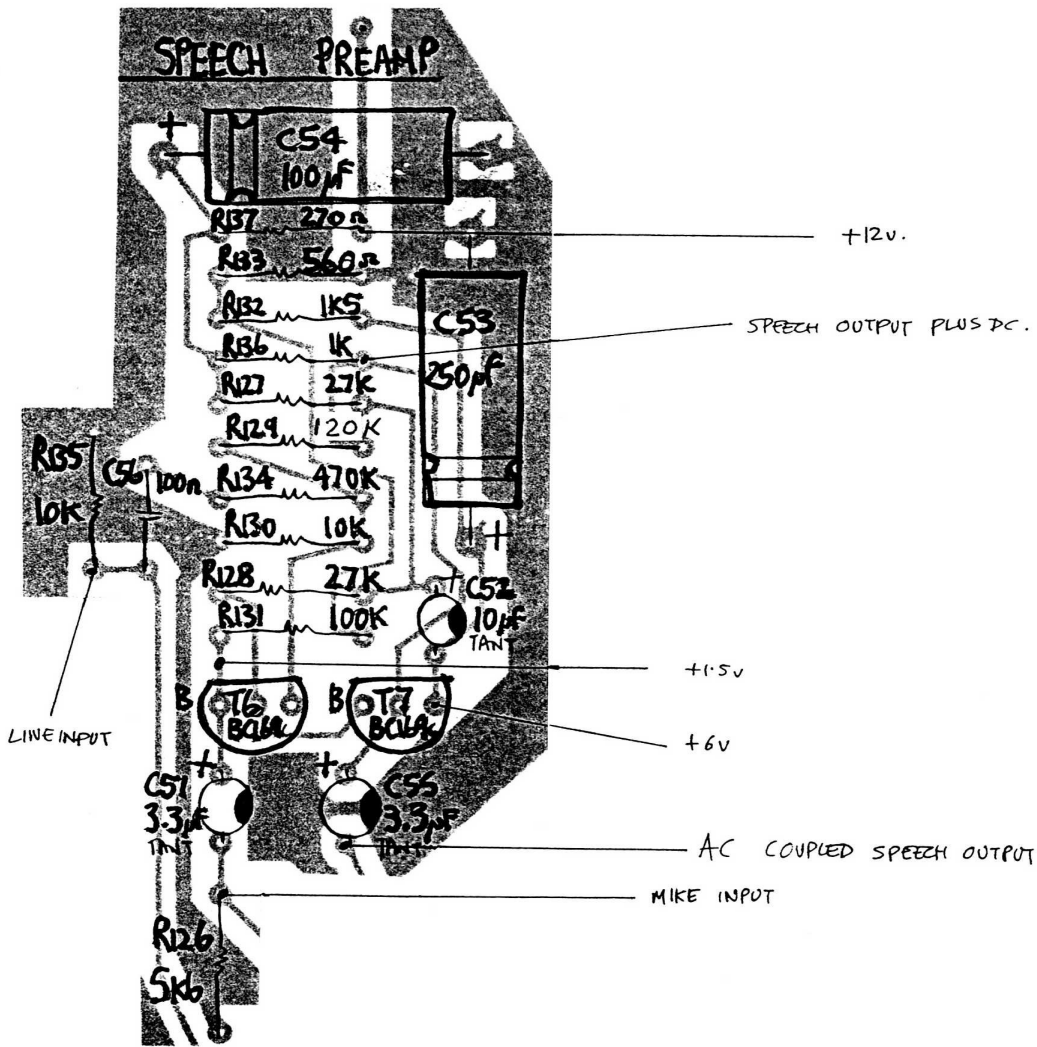

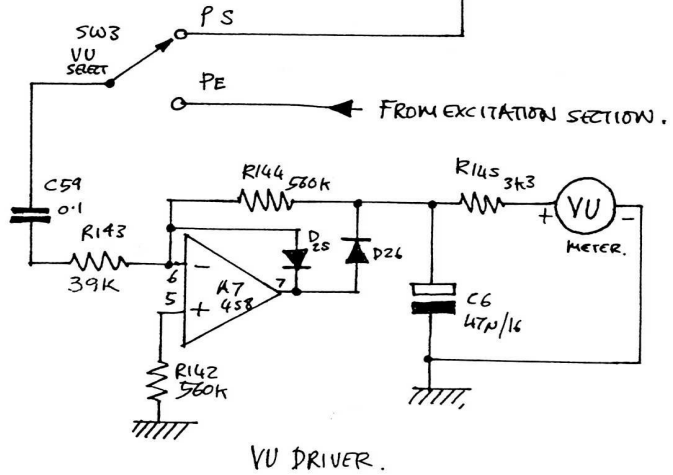
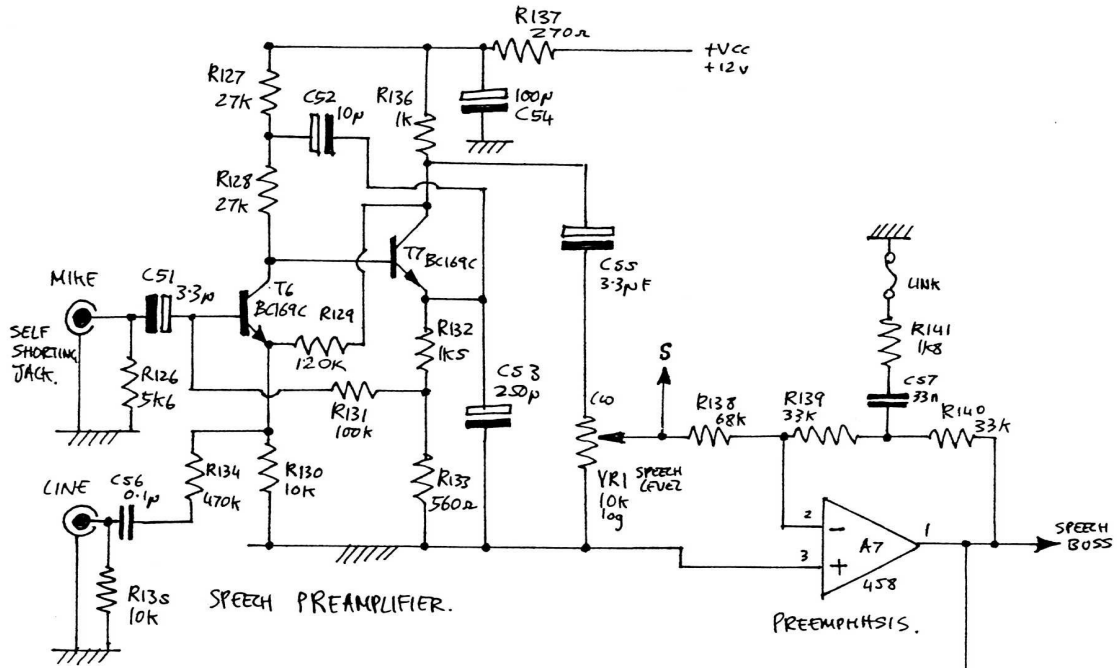

DRAWN: MAY /77. ©T. OPR.

★ V2000

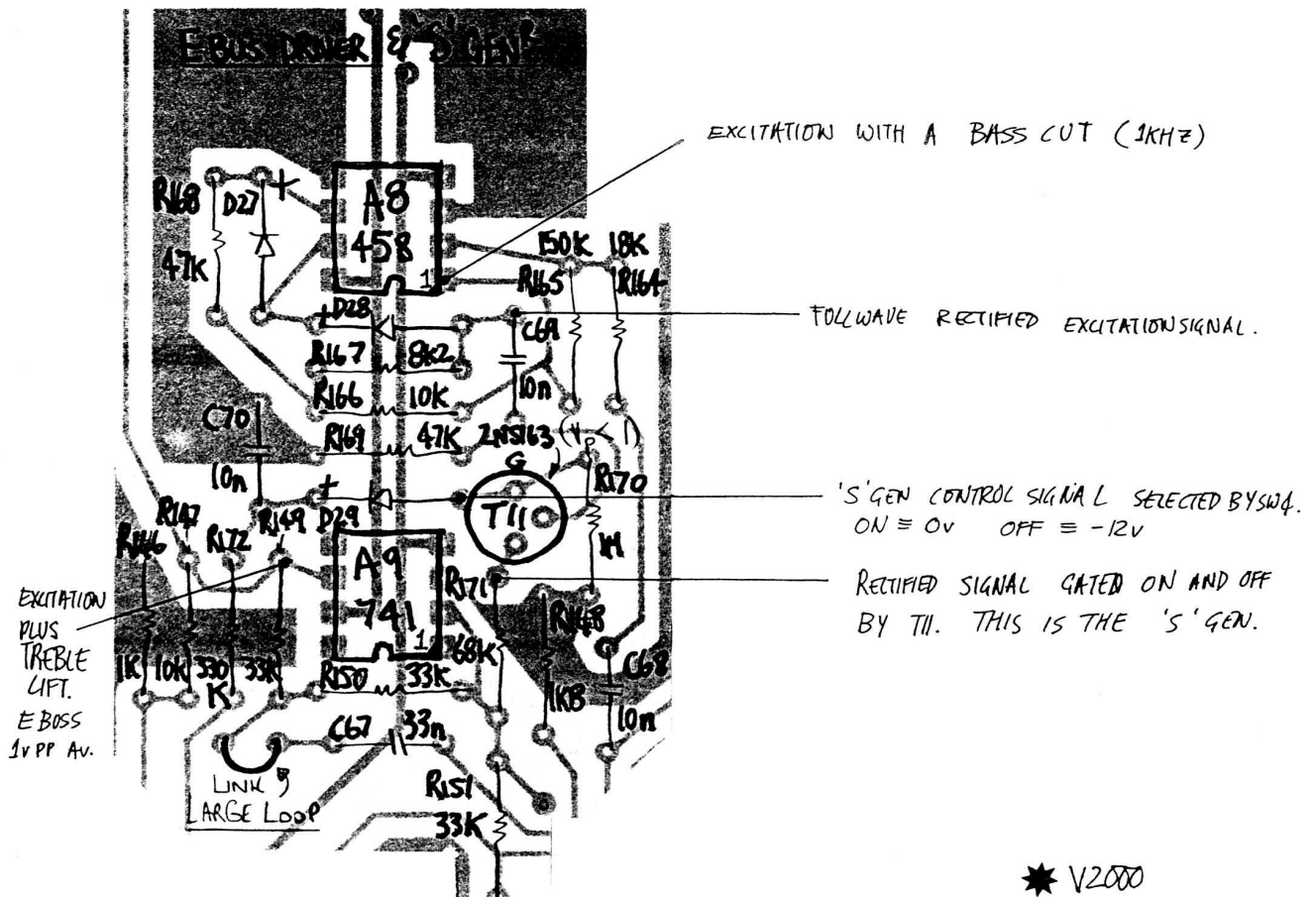
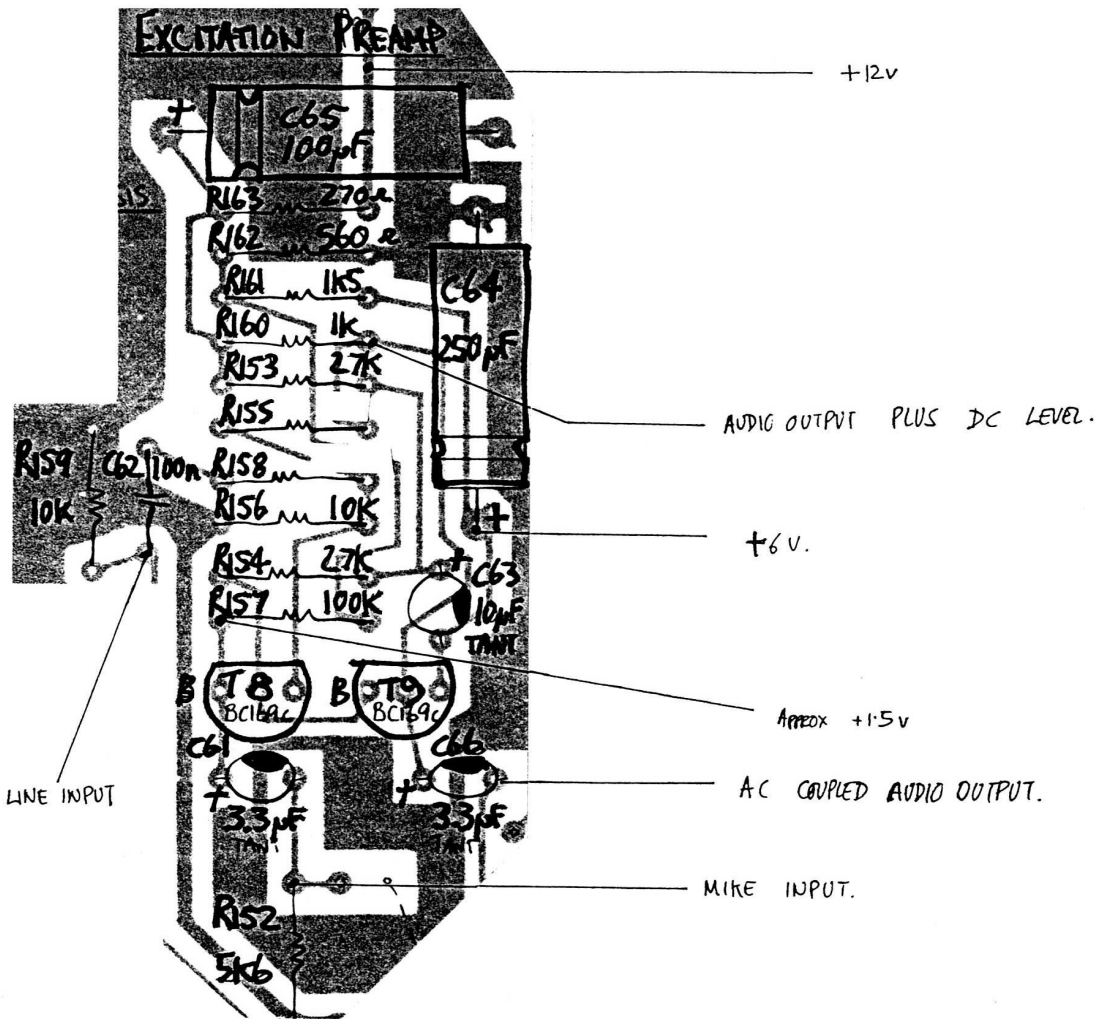

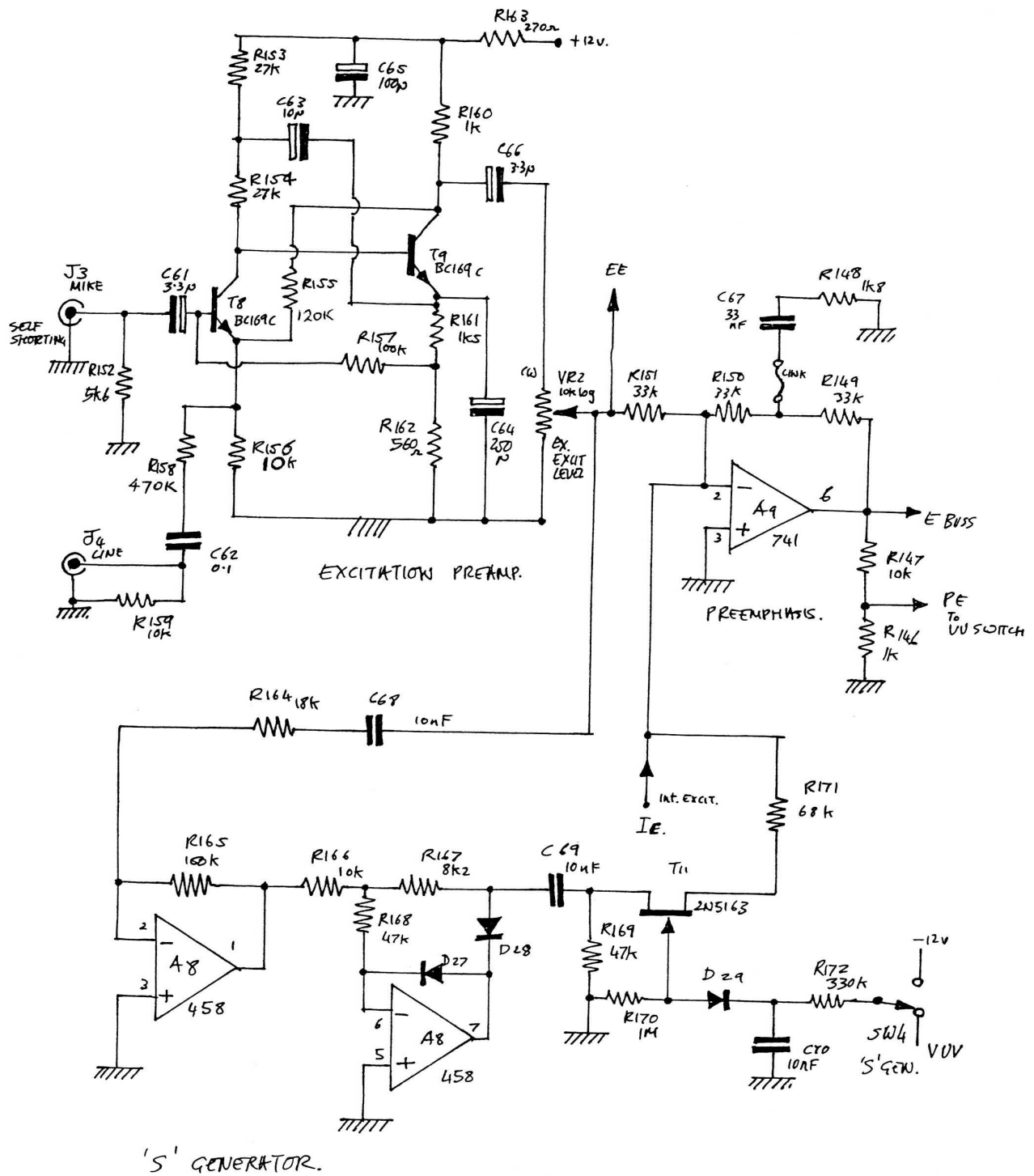

DRON MAY 1977 © T.ORK.

★ V2000

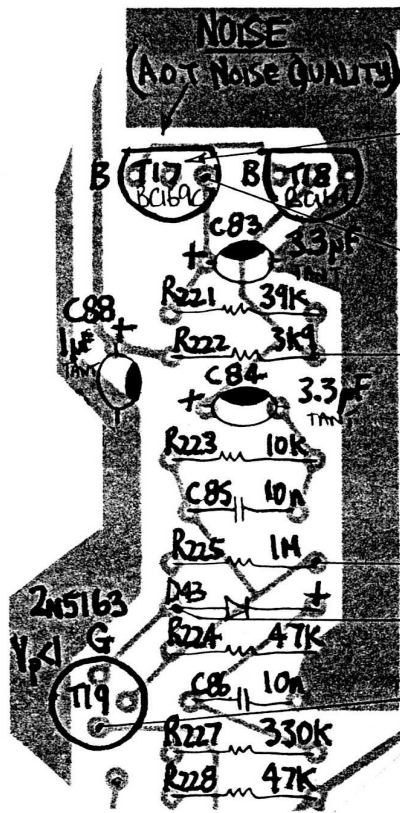

NOISE
(NOT NOISE QUALITY)

SELECTED NOISE TRANSISTOR.

+6v to +8v

NOISE SIGNAL PWS DC.

AC COUPLED NOISE SIGNAL.

CONTROL SIGNAL FOR GATE, ONE = 0V OFF = -12V

GATED NOISE OUTPUT, CONTROLLED BY SW5.

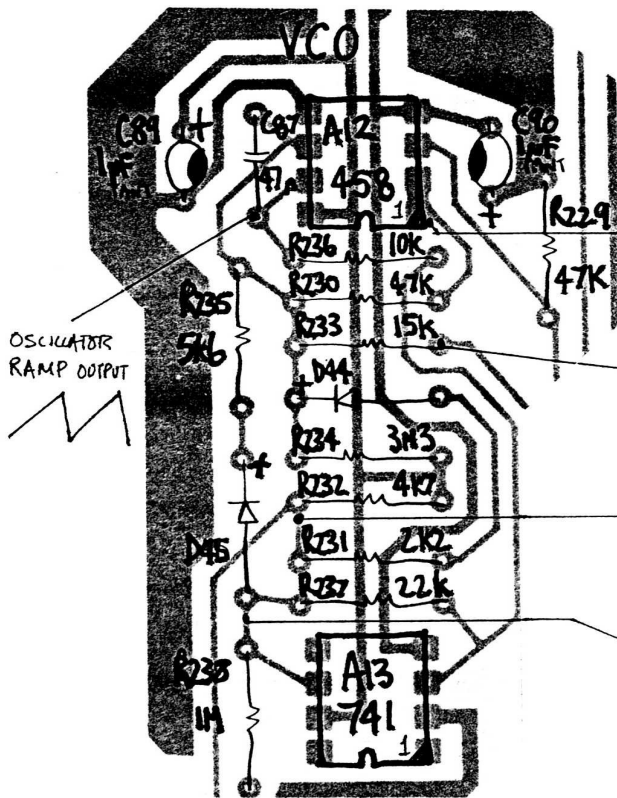

LF ENVELOPE FROM F1
MOVES WHEN SPEECH IS BEING
ANALYSED. CAN BE FROZEN.
SELECTED BY SW7.

PITCH CONTROL VOLTAGE 0 → -12V.

ON/OFF/VUV SWITCH. ONE = -12V OFF = +12V
VUV MOVES +V AND -V WITH
THE SPEECH SIGNAL.

OSCILLATOR PULSE OUTPUT

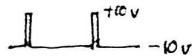

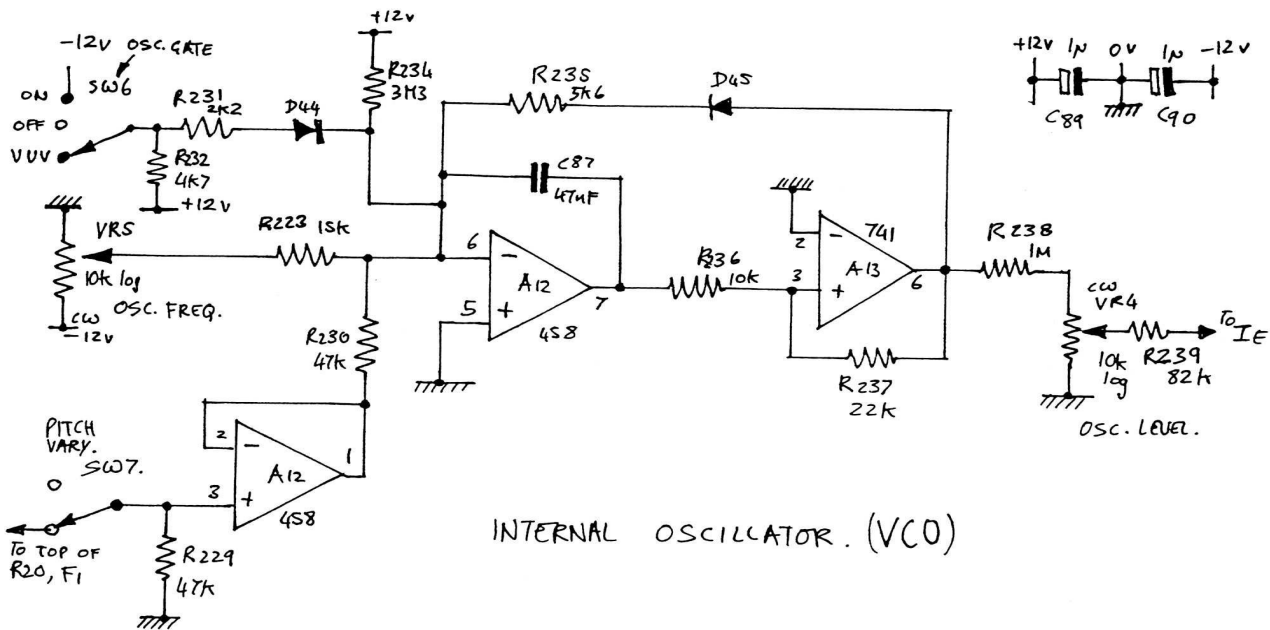
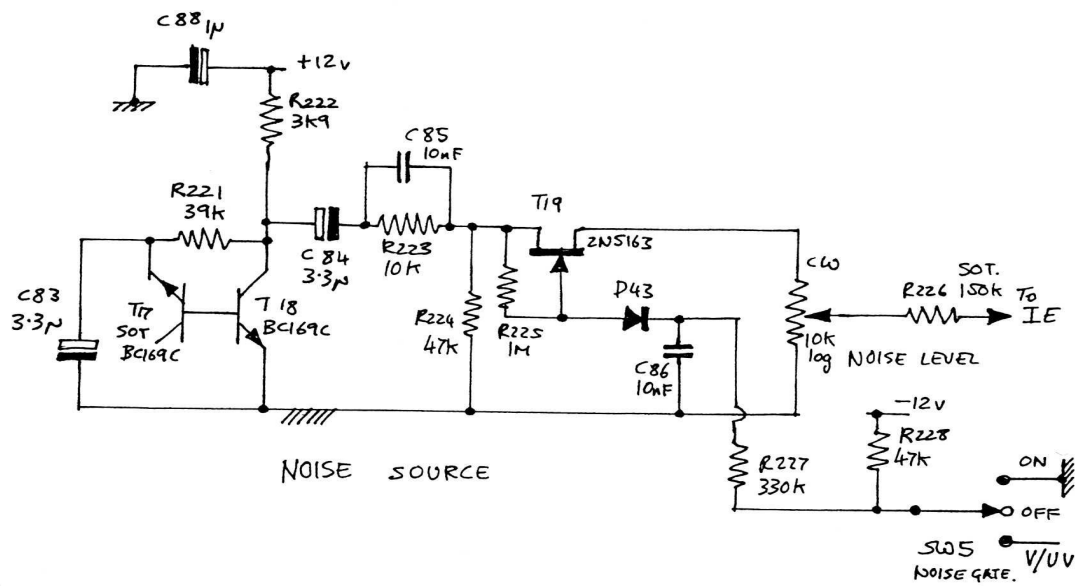

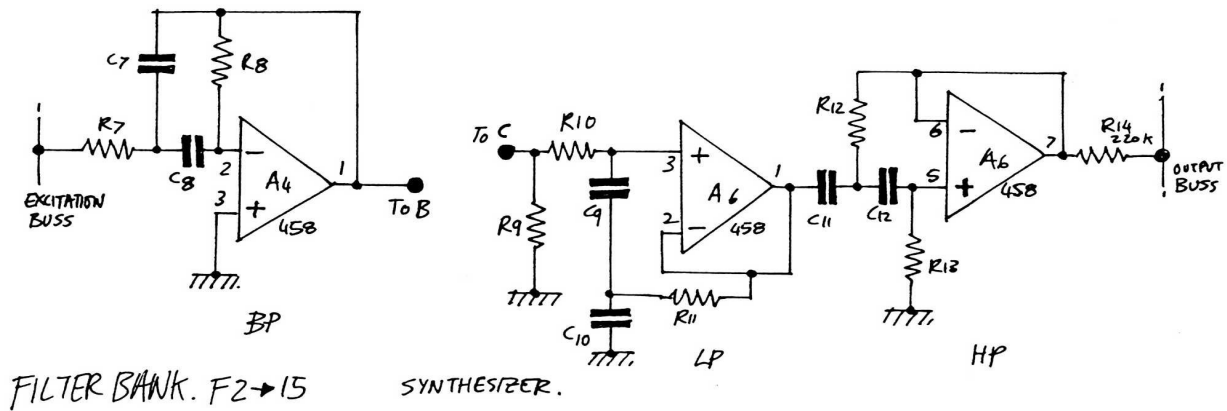
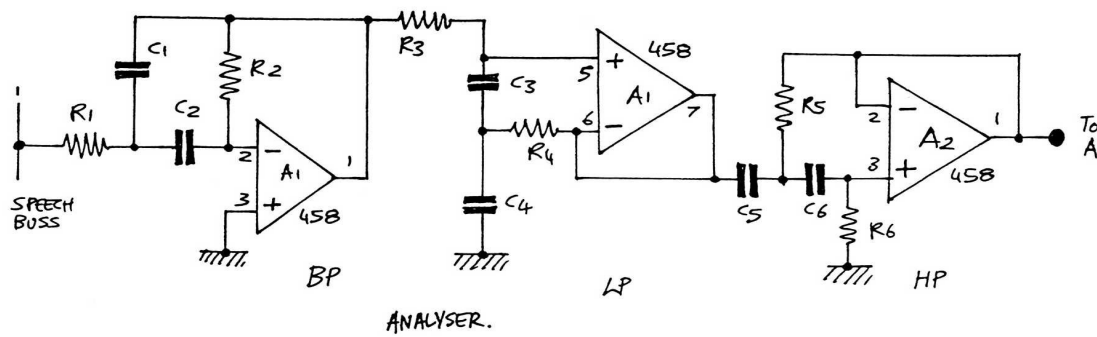
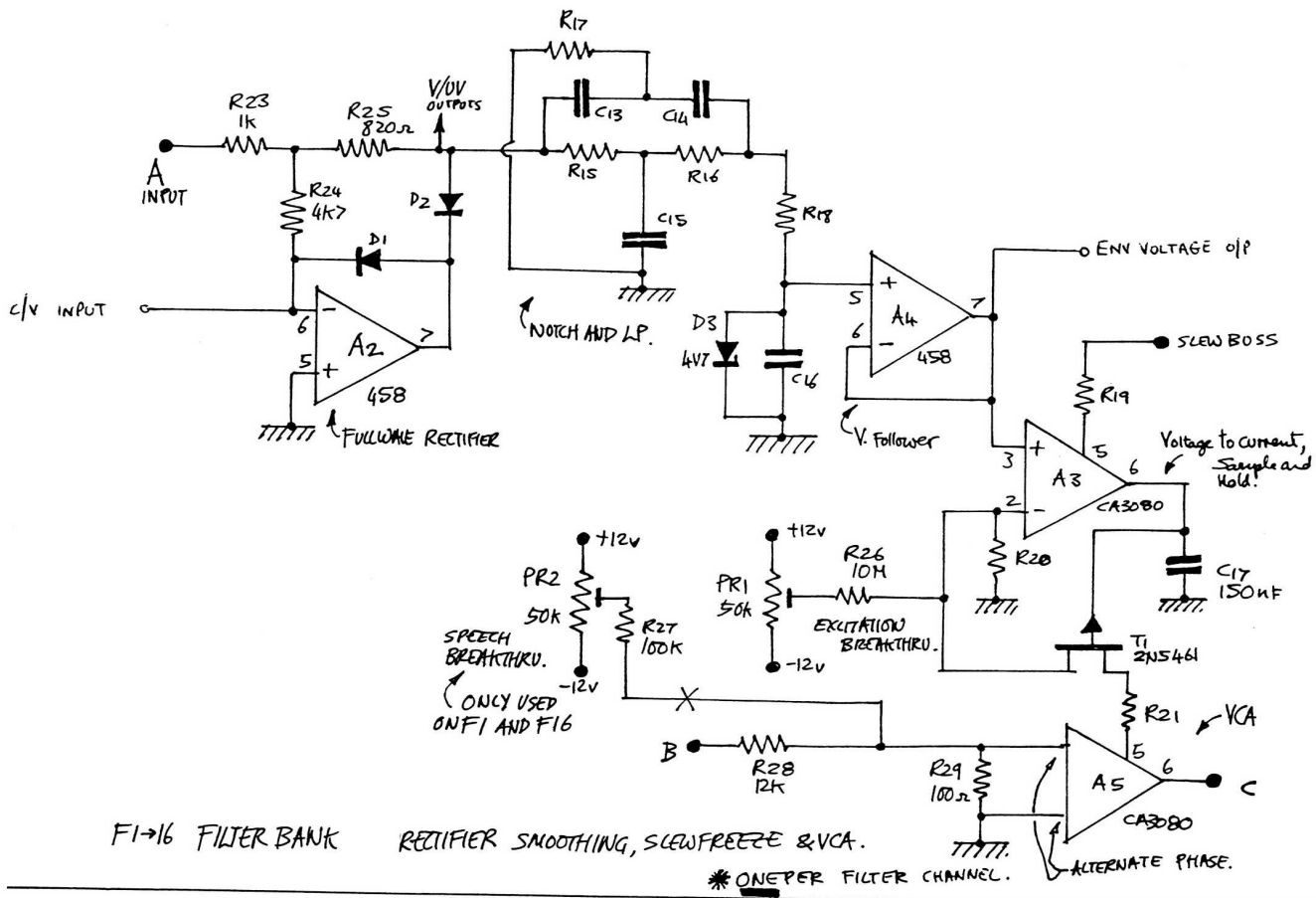

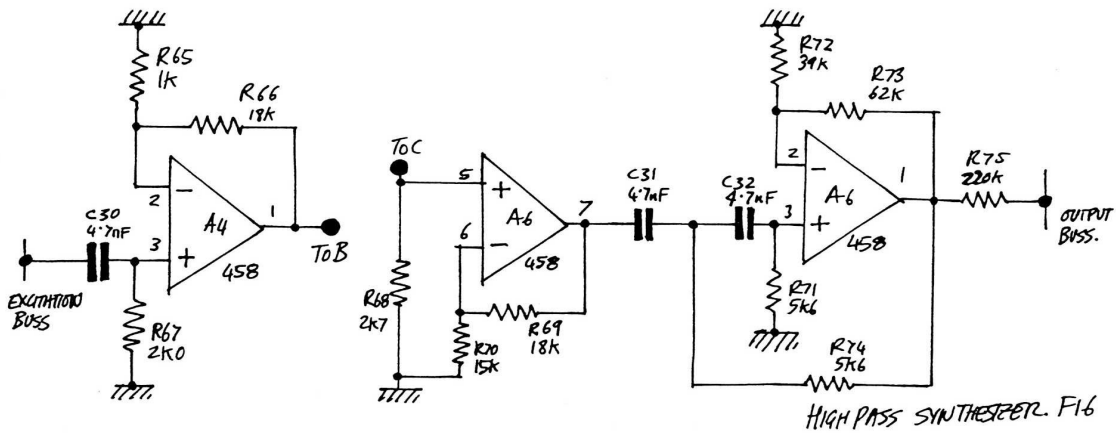
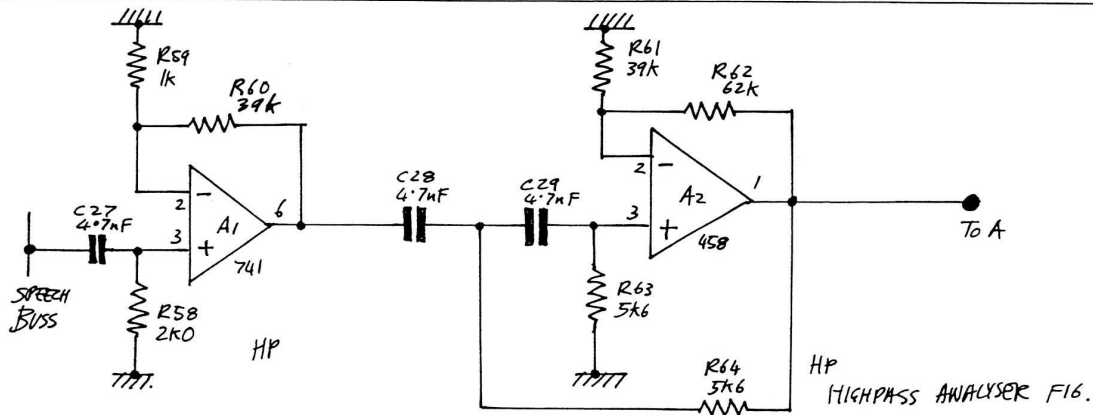
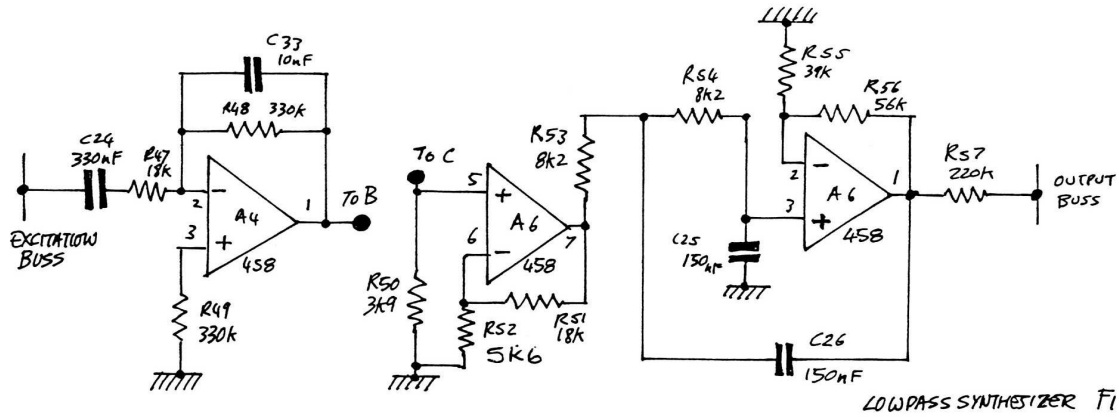
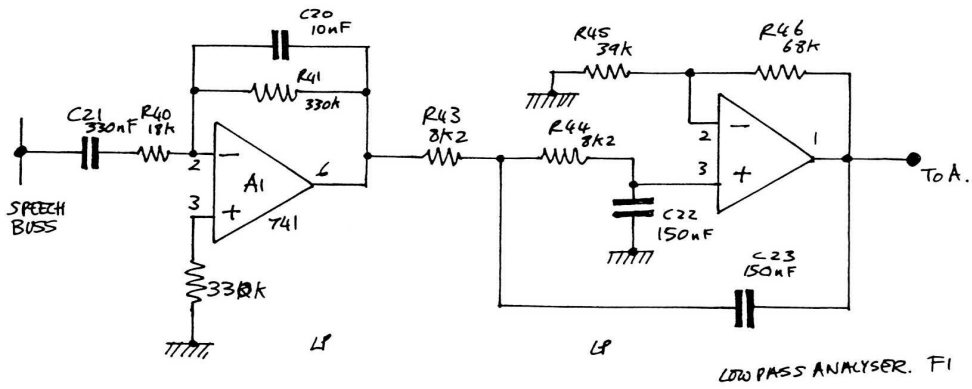

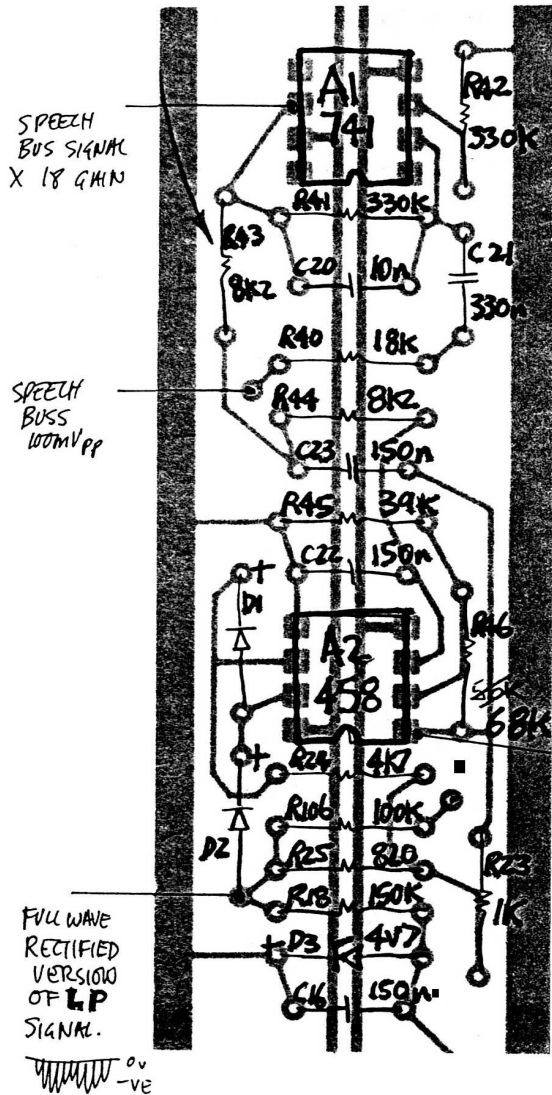

SPEECH BUS SIGNAL X 18 GAIN

SPEECH BUSS 100mVpp

FULL WAVE RECTIFIED VERSION OF LP SIGNAL.

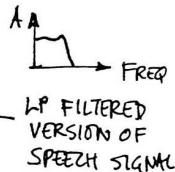

LP FILTERED ENVELOPE OF SPEECH SIGNAL

PRODUCT OF SPEECH ENVELOPE X THE FILTERED EXCITATION SIGNAL. ADJUST PR2 SO THAT WITH NO EXCITATION AND SOME SPEECH, THE SPEECH BREAKTHROUGH IS MINIMUM.

SAME AS ABOVE X 2.3 GAIN.

LOWPASS FILTER F1

X →

ADJUST SO THAT THERE IS NO EXCITATION BREAKTHROUGH. VARY THE SLEW KNOB WHEN SETTING UP.

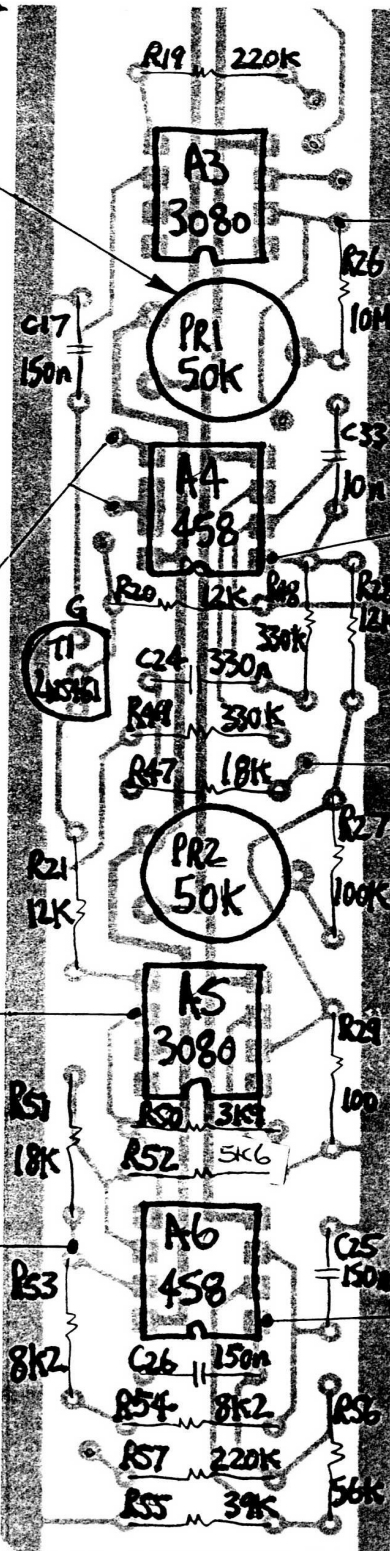

SAME AS A4 PIN7 AS LONG AS THE SLEW FREEZE FUNCTION IS SET AT FAST.

LP VERSION OF E BUSS SIGNAL X 18 GAIN.

E BUSS 1vpp

LP OUTPUT OF CHANNEL.

★ V2000

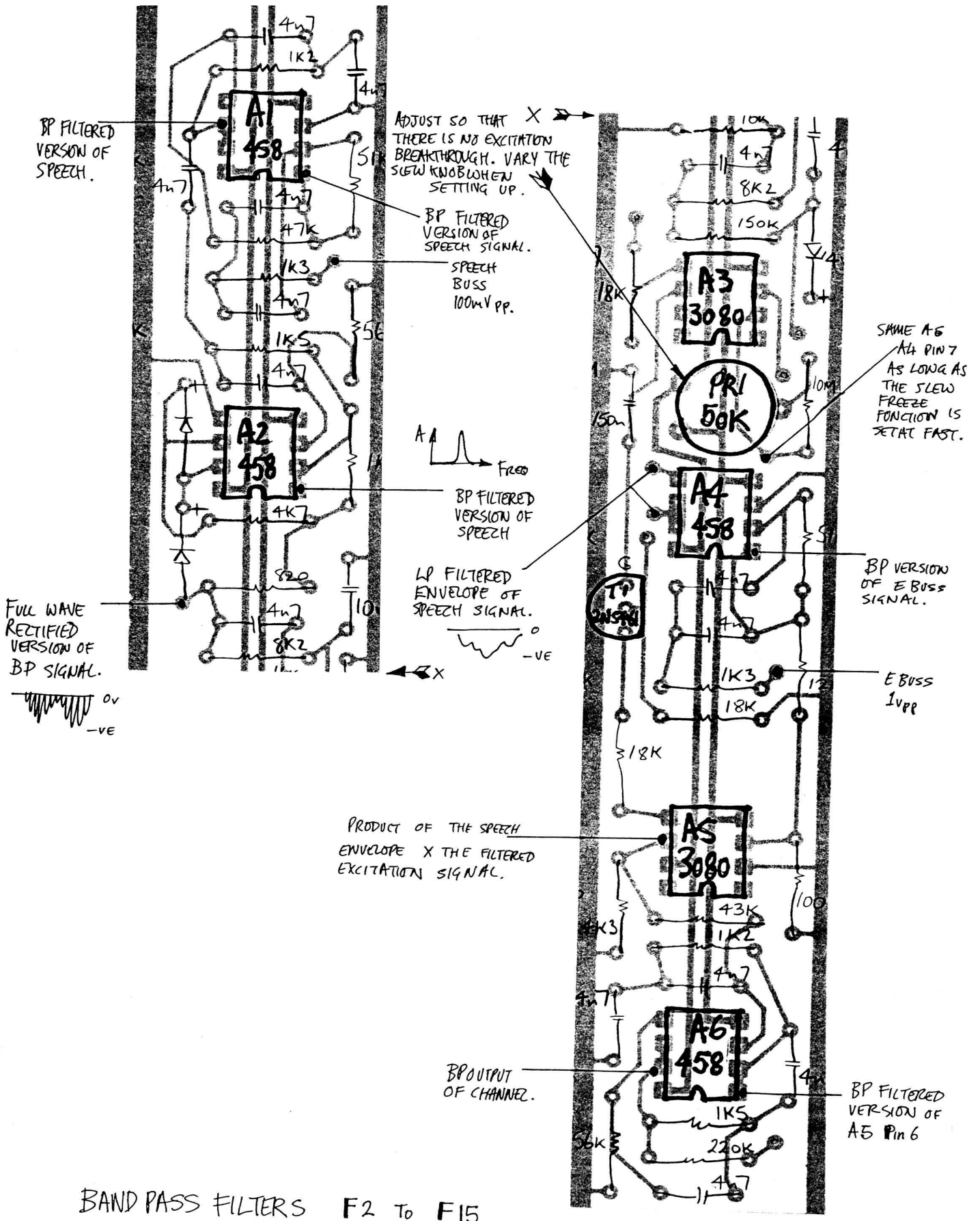

BAND PASS FILTERS F2 TO F15

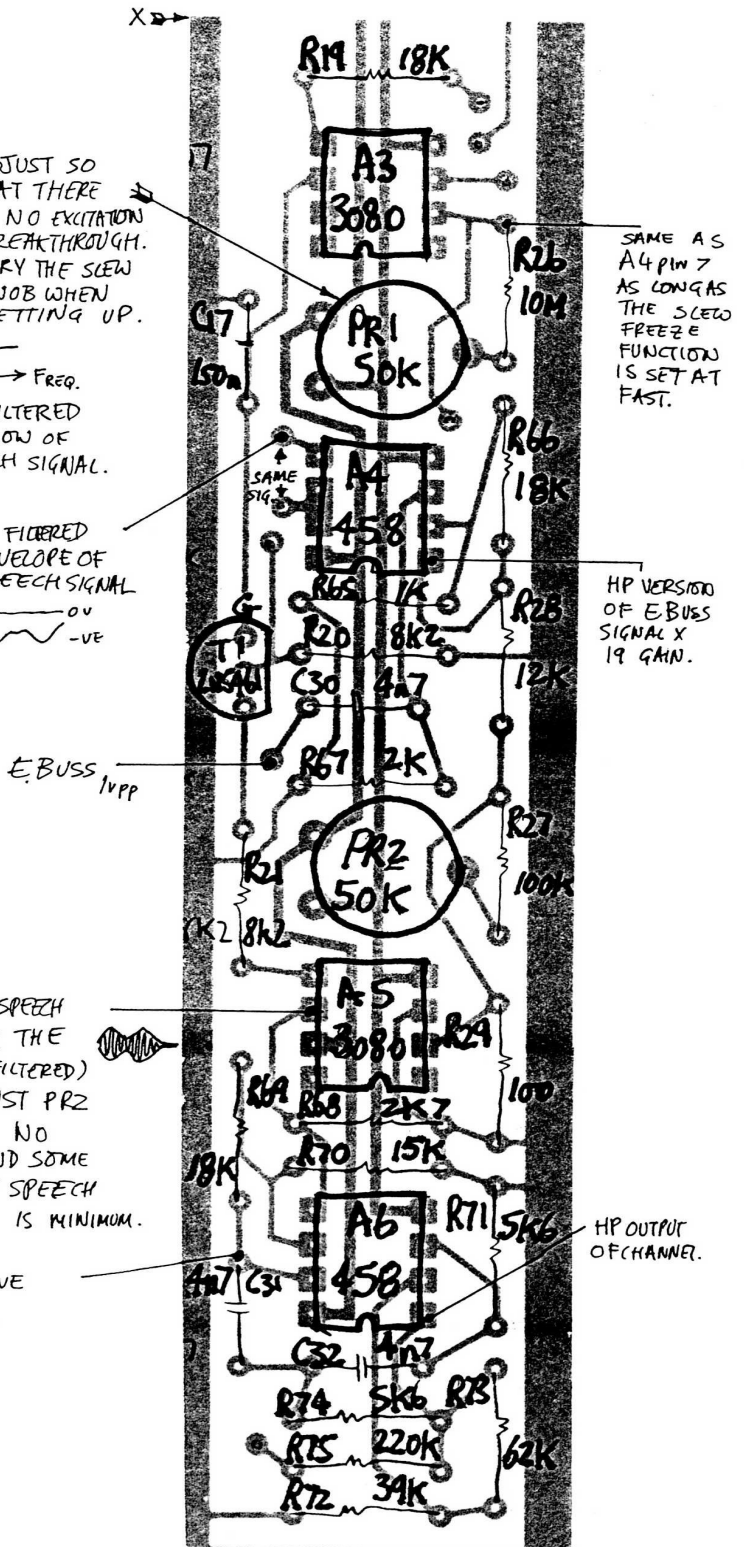
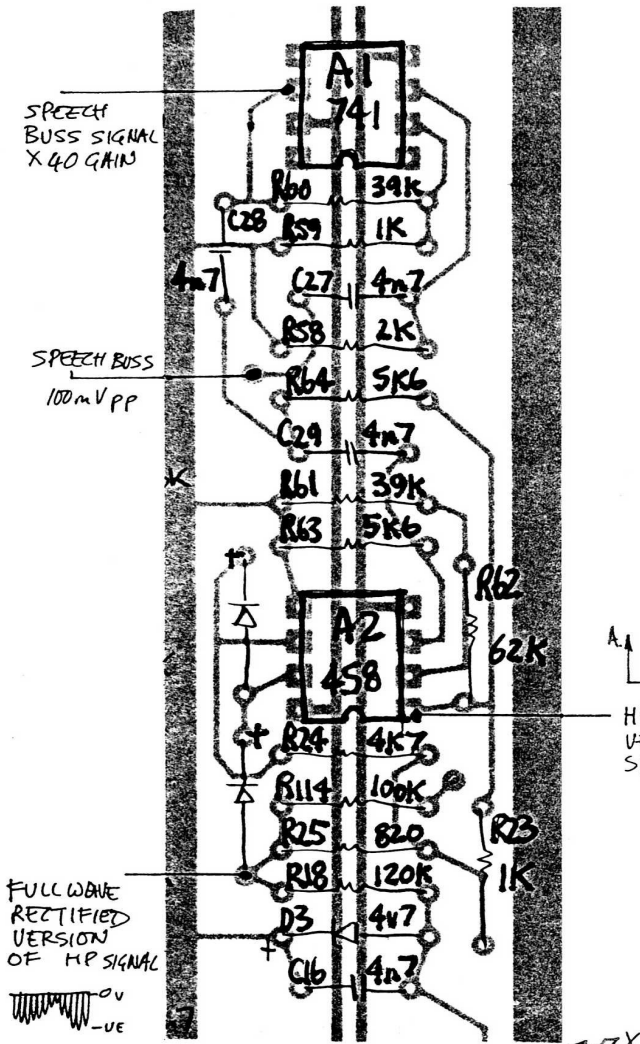

HIGH PASS FILTER, F16

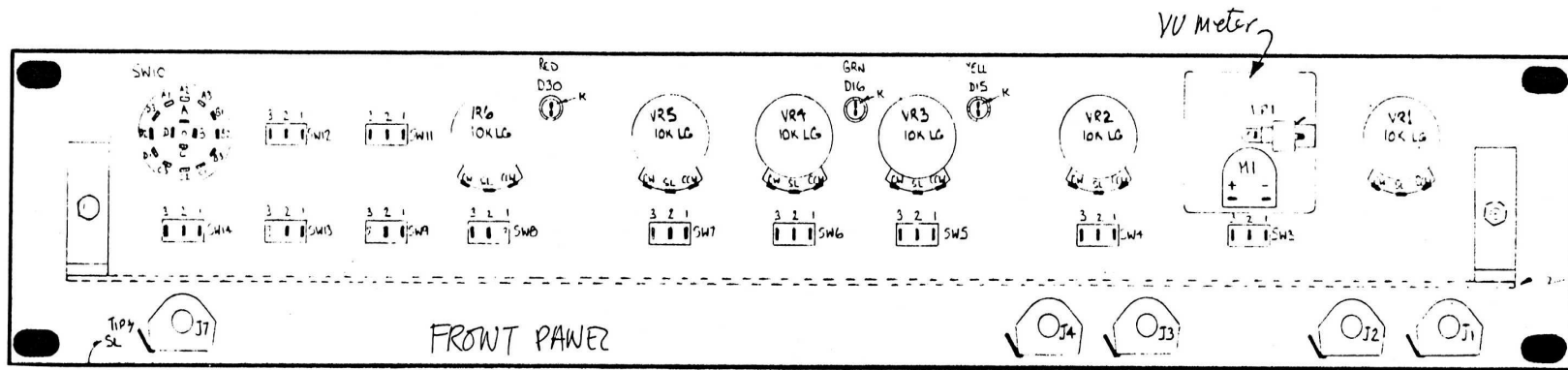
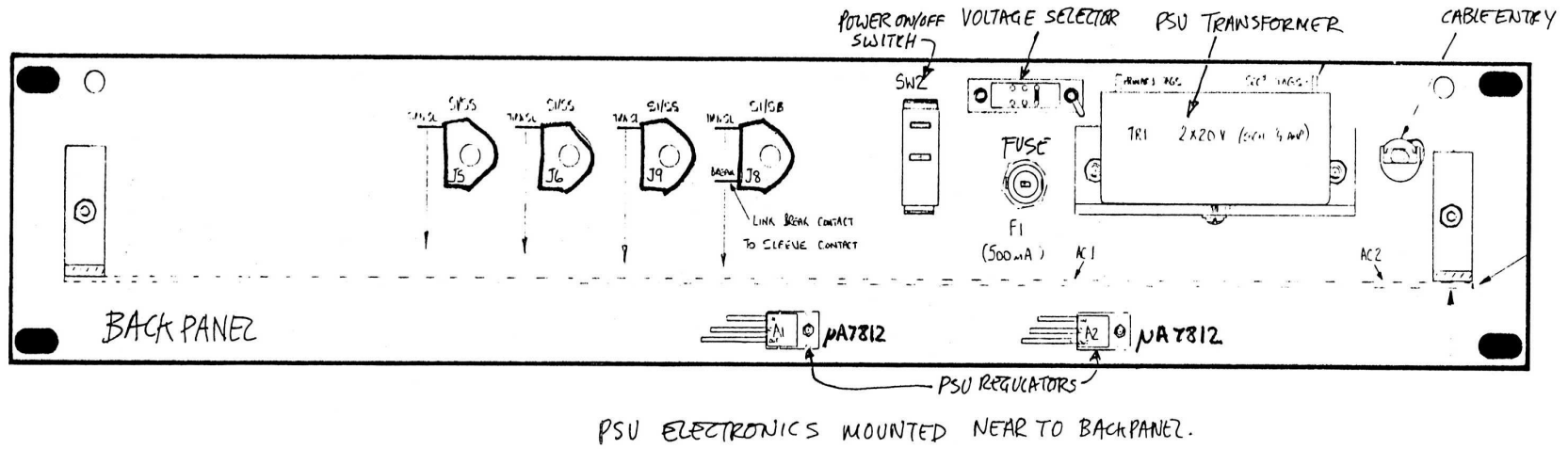

FRONT AND BACK PANEL COMPONENTS

★ Y2000

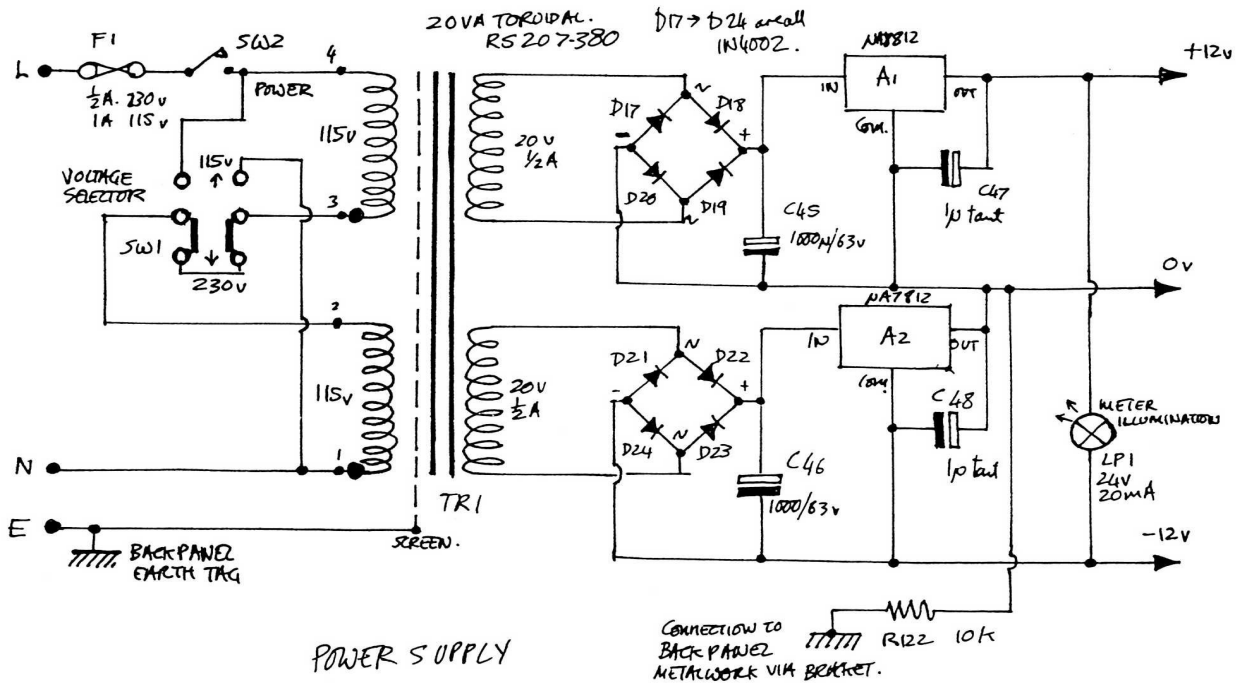

DRAWN MAY 1977 © T. ORR.

PARTS. GENERAL NOTES

ALL UNMARKED DIODES ARE IN4148 OR IN914 OR EQUIVILANTS CA3080. MADE BY RCA. NO EQUIVILANTS.

741. OP AMP MADE BY VIRTUALLY EVERY ONE.

458 DUAL 741. MADE BY MANY PRODUCERS*

- * CA1458 RCA
- U9T7SS8393 FAIRCHILD
- MC1458 MOTOROLA
- LM1458 NATIONAL SEMICONDUCTOR
- RC1458 RAYTHEON
- SG1458 SILICON GENERAL
- N5558 SIGNETICS
- SN72558 TEXAS INSTRUMENTS.

- 2N5163 GENERAL PURPOSE N FET.
- 2N5461 GENERAL PURPOSE P FET.
- BC169C LOW NOISE NPN TRANSISTOR
- BC258B LOW NOISE PNP TRANSISTOR

MA7812. 1/2A PLASTIC POSITIVE 12V REGULATOR.
 MOST PC CAPACITORS — MADE BY SIEMENS.

★ V2000