

Stereophonic

THE FISHER 800-B

SERVICE MANUAL

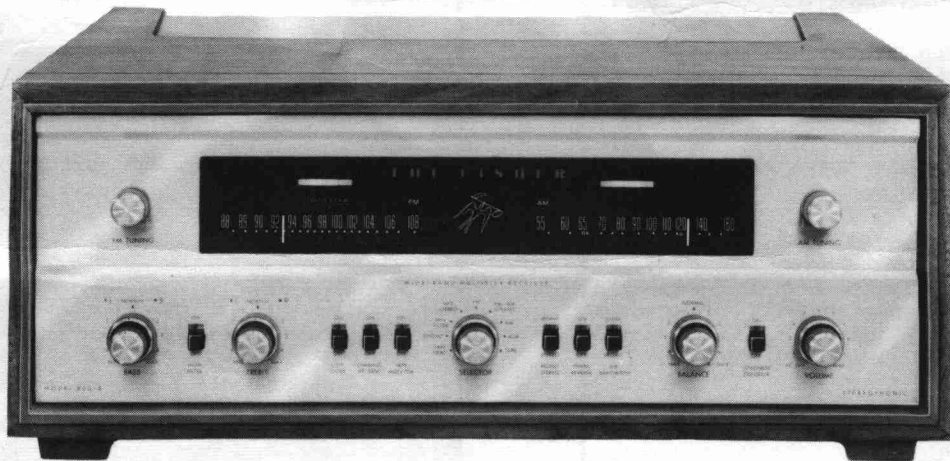

MODEL 800-B

CHASSIS SERIAL NUMBERS
FROM 20001 TO 29999 INCLUSIVE

PRICE: \$1.00

FISHER RADIO CORPORATION • NEW YORK



CHASSIS SERIAL NUMBERS
FROM 20001 TO 29999 INCLUSIVE

THE FISHER 800-B



PARTS DESCRIPTION LIST

CAPACITORS

10 % tolerance for all fixed capacitors, unless otherwise noted or marked GMV (guaranteed minimum value).

Symbol	Description	Part No.	Symbol	Description	Part No.
C1, 2	Ceramic, 100pf, GMV, 1000V	C50070-5	C77	Ceramic, 1800pf, 1000V	C50072-8
C3	Ceramic, 3pf, NPO, 1000V	C50070-28	C78, 79	Ceramic, 7pf, NPO, 1000V	C50070-20
C4	Ceramic, 21pf, 5 %, N750, 1000V	C50070-32	C80, 81	Ceramic, 330pf, 1000V	C50072-1
C5	Variable, AM	C860-119	C82	Ceramic, 560pf, 1000V	C50072-14
C6	Ceramic, 100pf, GMV, 1000V	C50070-5	C83	Electrolytic, 8uf, 50V	C629-138
C7	Ceramic, .02uf, +80 -20 %, 500V	C50089-4	C84	Ceramic, 100pf, GMV, N1500, 1000V	C50070-5
C8	Ceramic, 1000pf, GMV, 1000V	C50071-2	C85, 86	Ceramic, 330pf, 1000V	C50072-1
C9	Ceramic, feedthru, 1000pf, GMV	C592-187	C87	Mylar, .047uf, 400V	C50197-30
C10, 11	Ceramic, .02uf, +80 -20 %, 500V	C50089-4	C88	Mylar, .047uf, 250V	C50197-52
C12, 13	Ceramic, .01uf, 20 %, 500V	C50089-3	C89	Mylar, .047uf, 400V	C50197-30
C14	Ceramic, feedthru, 1000pf, GMV	C592-187	C90	Mylar, .047uf, 250V	C50197-52
C15	Ceramic, 5pf, ±.5pf, NPO, 500V	CC20CJ050D5	C91	Ceramic, feedthru, 1000pf, GMV	C592-187
C16	Mylar, .022uf, 250V	C50197-49	C92, 93	Ceramic, 18pf, N470, 1000V	C50070-13
C17	Ceramic, Trimmer	C662-123	C94	Ceramic, 5000pf, +80 -20 %, 500V	C50089-6
C18	Ceramic, 1000pf, GMV, 1000V	C50071-2	C95	Electrolytic, 3 section:	C50180-18
C19	Variable, FM	C899-111		A — 20uf, 300V	
C20	Ceramic, 100pf, GMV, 1000V	C50070-5	C96	Electrolytic, 4 section:	C50180-21
C21	Ceramic, 33pf, 5 %, N750, 1000V	C50070-25		A — 50uf, 250V	
C22	Ceramic, Trimmer	C662-123		B — 50uf, 250V	
C23	Ceramic, 5000pf, +80 -20 %, 500V	C50089-6		C — 50uf, 250V	
C24	Ceramic, 24pf, 5 %, N150, 1000V	C50070-8		D — 50uf, 250V	
C25	Ceramic, 100pf, GMV, 1000V	C50070-5	C97	Ceramic, 5000pf, +80 -20 %, 500V	C50089-6
C26	Ceramic, 5pf, ±.5pf, NPO, 500V	CC20CJ050D5	C98	Electrolytic, 2 section:	C50180-38
C27	Ceramic, 100pf, 5 %, N750, 1000V	C50070-19		A — 1000uf, 35V	
C28	Ceramic, 1000pf, 1000V	C50072-3		B — 1000uf, 35V	
C29	Ceramic, 10pf, ±.5pf, N150, 500V	CC20PJ100D5	C99, 100	Ceramic, 5000pf, +80 -20 %, 500V	C50089-6
C30	Ceramic, 21pf, 5 %, N750, 1000V	C50070-32	C101	Electrolytic, 2 section:	C50180-19
C31	Ceramic, 10pf, NPO, 1000V	C50070-11		A — 40uf, 500V	
C32	Ceramic, feedthru, 1000pf, GMV	C592-187		B — 200uf, 250V	
C33	Ceramic, 27pf, N150, 1000V	C50070-10	C102	Electrolytic, 200uf, 250V	C50180-20
C34	Ceramic, 21pf, 5 %, N750, 1000V	C50070-32	C103	Molded, .01uf, 20 %, 600V	C2747
C35, 36	Ceramic, 1000pf, GMV, 500V	C50089-2	C104, 105	Ceramic, 5000pf, +80 -20 %, 500V	C50089-6
C37	Ceramic, .02uf, 20 %, 500V	C50089-5	C106	Molded, .01uf, 20 %, 600V	C2747
C38	Ceramic, 2200pf, 1000V	C50072-5	C107, 108	Ceramic, 330pf, 1000V	C50072-1
C39	Ceramic, .02uf, 20 %, 500V	C50089-5			
C40	Ceramic, 2200pf, 1000V	C50072-5			
C41	Ceramic, 5000pf, +80 -20 %, 500V	C50089-6			
C42	Ceramic, 2700pf, 1000V	C50072-17			
C43	Ceramic, 5000pf, +80 -20 %, 500V	C50089-6			
C44	Ceramic, .02uf, +80 -20 %, 500V	C50089-4			
C45	Ceramic, .68pf, 20 %, 500V	C50077-6N			
C46	Ceramic, 47pf, 5 %, N750, 1000V	C50070-29			
C47	Mylar, .022uf, 250V	C50197-49			
C48	Ceramic, 5000pf, +80 -20 %, 500V	C50089-6			
C50	Ceramic, .02uf, +80 -20 %, 500V	C50089-4			
C54	Electrolytic, 20uf, 250V	C746-145			
C55, 56	Ceramic, 5000pf, +80 -20 %, 500V	C50089-6			
C57, 58	Ceramic, 82pf, N1500, 1000V	C50070-7			
C59	Ceramic, 5000pf, +80 -20 %, 500V	C50089-6			
C60, 61	Mylar, .047uf, 400V	C50197-30			
C62	Ceramic, .02uf, 20 %, 500V	C50089-5			
C63	Ceramic, 2700pf, 1000V	C50072-17			
C64	Ceramic, 5000pf, +80 -20 %, 500V	C50089-6			
C65	Ceramic, 100pf, N1500, 1000V	C50070-6			
C66	Mylar, .047uf, 250V	C50197-52			
C67	Ceramic, 5000pf, +80 -20 %, 500V	C50089-6			
C68, 69	Ceramic, 470pf, 1000V	C50072-13			
C70	Ceramic, 2700pf, 1000V	C50072-17			
C71, 72	Ceramic, 68pf, 1000V	C50070-12			
C73	Ceramic, 330pf, 1000V	C50072-1			
C74, 75	Ceramic, .02uf, 20 %, 500V	C50089-5			
C76	Ceramic, .05uf, +80 -20 %, 100V	C50073-2			

RESISTORS AND POTENTIOMETERS

In ohms, 10 % tolerance, 1/2 watt, unless otherwise noted. K = kilohm, M = megohm.

Symbol	Description	Part No.
R1	Composition, 270	RC20BF271K
R2	Composition, 100K	RC20BF104K
R3, 4, 5	Dep. Carbon, 100K, 5 %, 1/3 W	R33DC104J
R6	Composition, 10	RC20BF100K
R7	Composition, 820K	RC20BF824K
R8	Dep. Carbon, 100K, 5 %, 1/3 W	R33DC104J
R9	Composition, 10	RC20BF100K
R10	Composition, 100K	RC20BF104K
R11	Composition, 1.5M	RC20BF155K
R12	Composition, 100	RC20BF101K
R13	Dep. Carbon, 10K, 5 %, 1/3 W	R33DC103J
R14	Glass, 2.7K, 5 %, 1W	R30G272J
R15	Dep. Carbon, 10K, 5 %, 1/3 W	R33DC103J
R16	Glass, 2.7K, 5 %, 1W	R30G272J
R17, 18	Glass, 330K, 5 %, 1W	R30G334J
R19, 20	Dep. Carbon, 4.7M, 5 %, 1/3 W	R33DC475J
R21	Dep. Carbon, 47K, 5 %, 1/3 W	R33DC473J
R22, 23	Dep. Carbon, 220K, 5 %, 1/3 W	R33DC224J
R24	Composition, 470	RC20BF471K
R25, 26	Potentiometer, 250K, Low Level	R50103-1
R27	Dep. Carbon, 330K, 5 %, 1/3 W	R33DC334J
R28	Composition, 22K	RC20BF223K
R29	Composition, 150K	RC20BF154K
R30	Composition, 18K, 1W	RC30BF183K
R31	Composition, 100	RC20BF101K

PARTS DESCRIPTION LIST

R32, 33 Composition, 560K, 5 %
R34 Composition, 82K, 5 %
R35 Dep. Carbon, 330K, 5 %, 1/3 W
R36 Composition, 1K
R37 Composition, 82K, 5 %
R38, 39 Dep. Carbon, 470K, 5 %, 1/3 W
R40, 41 Composition, 2.7M, 5 %
R42 Composition, 270
R43, 44 Composition, 1.2M, 5 %
R45 Composition, 270
R46, 47 Dep. Carbon, 1K, 5 %, 1/3 W
R48 Composition, 150
R49, 50 Composition, 120K
R51 Composition, 270
R52 Composition, 1K
R53 Composition, 180
R54 Composition, 680K
R55 Potentiometer, dual, 500K, Base
R56 Composition, 680K
R57 Dep. Carbon, 2.2M, 5 %, 1/3 W
R60 Potentiometer, dual, 500K, Treble
R62, 63 Dep. Carbon, 220K, 5 %, 1/3 W
R64 Composition, 27K
R65 Composition, 1K
R66 Composition, 150
R67, 68 Composition, 10M
R69 Composition, 82K, 5 %
R70, 71 Composition, 3.3M, 5 %
R72 Composition, 180K
R73 Dep. Carbon, 47K, 5 %, 1/3 W
R74 Dep. Carbon, 2.2M, 5 %, 1/3 W
R75, 76 Dep. Carbon, 220K, 5 %, 1/3 W
R77, 78 Composition, 560, 5 %
R79 Composition, 1K
R80, 81 Dep. Carbon, 220K, 5 %, 1/3 W
R82 Dep. Carbon, 47K, 5 %, 1/3 W
R84 Composition, 10M
R85, 86 Dep. Carbon, 47K, 5 %, 1/3 W
R89 Potentiometer, 500K, Balance
R90 Composition, 56K
R91, 92 Composition, 470K
R94 Composition, 270
R95, 96 Dep. Carbon, 22K, 5 %, 1/3 W
R97, 98, 99 Dep. Carbon, 47K, 5 %, 1/3 W
R100 Potentiometer, dual, 500K, Volume
R102 Composition, 390K, 5 %
R103 Composition, 1.2K, 5 %
R104 Composition, 220
R105 Composition, 390K, 5 %
R106 Composition, 1.2K, 5 %
R107 Composition, 220
R108 Composition, 1.5K
R109 Composition, 1K
R110 Composition, 15K
R111 Potentiometer, 25K
R112 Dep. Carbon, 33K, 5 %, 1/3 W
R113 Potentiometer, 25K
R114 Dep. Carbon, 33K, 5 %, 1/3 W
R115 Composition, 68K, 5 %
R116 Composition, 3.9K, 5 %
R117 Composition, 68K, 5 %
R118 Composition, 3.9K, 5 %
R119 Composition, 180K
R120 Dep. Carbon, 330K, 5 %, 1/3 W
R121 Composition, 3.9M
R122, 123 Composition, 150K

RC20BF564J
RC20BF823J
R33DC334J
RC20BF102K
RC20BF823J
R33DC474J
RC20BF275J
RC20BF271K
RC20BF125J
RC20BF271K
R33DC102J
RC20BF151K
RC20BF124K
RC20BF273K
RC20BF102K
RC20BF181K
RC20BF684K
R50160-101-1
RC20BF684K
R33DC225J
R50160-101-2
R33DC224J
RC20BF273K
RC20BF102K
RC20BF151K
RC20BF106K
RC20BF823J
RC20BF335J
RC20BF184K
R33DC473J
R33DC225J
R33DC224J
RC20BF561J
RC20BF102K
R33DC224J
R33DC473J
RC20BF106K
R33DC473J
R50160-103
RC20BF563K
RC20BF474K
RC20BF271K
R33DC223J
R33DC473J
R50160-104
RC20BF394J
RC20BF122J
RC20BF221K
RC20BF394J
RC20BF125J
RC20BF221K
RC20BF152K
RC20BF102K
RC20BF153K
R50103-2
R33DC333J
R50103-2
R33DC333J
RC20BF683J
RC20BF392J
RC20BF683J
RC20BF392J
RC20BF184K
R33DC334J
RC20BF395K
RC20BF154K

R124 Composition, 100K
R125 Dep. Carbon, 10K, 5 %, 1/3 W
R126 Composition, 5.6K, 5 %
R127, 128 Composition, 220
R129, 130, 131, 132 Dep. Carbon, 330K, 5 %, 1/3 W
R133 Composition, 22K
R134 Glass, 125, 3W
R135, 136, 137, 138 Dep. Carbon, 1K, 5 %, 1/3 W
R139 Composition, 2.7K
R140 Glass, 125, 3W
R141 Wirewound, 15, 5W
R142 Composition, 1.2K, 1W
R143 Glass, 125, 3W
R144 Glass, 1.2K, 7W
R145 Glass, 125, 3W
R146, 147, 148 Composition, 1K
R149 Composition, 820K
R150 Composition, 1.5K
R151 Composition, 1K

RC20BF104K
R33DC103J
RC20BF562J
RC20BF221K
R33DC334J
RC20BF223K
RPG3W125K
R33DC102J
RC20BF272K
RPG3W125K
R719-106
RC20BF122K
RPG3W125K
RPG7W122K
RPG3W125K
RC20BF102K
RC20BF824K
RC20BF152K
RC20BF102K

COILS, CHOKES & TRANSFORMERS

Symbol	Description	Part No.
L1	AM Loop	L50210-29
L2	FM Antenna	L818-113
L3	Choke, 1.5 Micro Henry	L50066-4
L4	Choke, RF	L629-180
L5	Coil, FMRF	L899-116
L6	Coil, FM Oscillator	L899-115
L7	Choke, .68 Micro Henries	L50066-1
L8	Choke, .2 Micro Henries	L50066-21
L9	Coil, AM Oscillator	L50210-28
L10	Choke, 3.3 Micro Henries	L50066-8
T1	Transformer, Power	T860-142
T2	Transformer, Output Channel A	T860-116-3
T3	Transformer, Output Channel B	T860-116-4
Z1	AM, RF Transformer	L50210-27
Z2	FM, IF Transformer	ZZ662-117
Z3	AM, IF Transformer	ZZ50210-1
Z4	FM, IF Transformer	ZZ2987
Z5	AM, IF Transformer	ZZ2984
Z6	FM Limiter	L670-145
Z7	FM Ratio Detector	ZZ50210-9

MISCELLANEOUS

Symbol	Description	Part No.
CR3, 4	Silicon Diode, High Voltage	SR806-126
F1	Fuse, 3.2 Amps, Slo-Blo	F3319
I1, 2	Dial Lamps	I50082-8
PC1, 2	Printed Cir., Phono, Tape Equalization	PC50187-3
PC3, 4	Printed Circuit, Tone Control	PC50187-9
PC5, 6	Printed Circuit, High Filter	PC50187-2
S1	Switch, Selector	S860-124
S2, 3, 4, 5, 6, 7, 8, 9	Switch, Slide	S50200-5
S10	Switch, Power	Part of R100
SR1	Selenium Rectifier, Bridge Type	SR755-140
—	FM Dipole	A550227-1
—	Dress Panel	AS860-108-1
—	Knob, Tuning	E50325-2
—	Knob, Dual, Back	E50221
—	Knob, Dual, Front	E50323
—	Knob, Dummy, Dual	E50324
—	Dial, Glass	N860-109

PARTS DESCRIPTION LIST • MULTIPLEX SECTION

CAPACITORS

10% tolerance for all fixed capacitors, unless otherwise noted or marked GMV (guaranteed minimum value). All capacitors not marked uf are pF (uuf).

Symbol	Description	Part No.
C200	Ceramic, .01uf, +80 -20%, 500V	C50089-7
C201	Ceramic, 680, 1000V	C50072-2
C203	Ceramic, 220, 1000V	C50183-3
C204	Mica, 470, 5%, 300V	C50332-4
C205	Ceramic, 82, N1500, 1000V	C50070-7
C206	Ceramic, .001uf, GMV, 500V	C50089-2
C207	Ceramic, .005uf, +80 -20%, 500V	C50089-6
C208, 209	Mica, 4700, 5%, 500V	C50332-5
C210	Electrolytic, .1uf, 350V	C50283-3
C211, 212	Ceramic, .001uf, GMV, 500V	C50089-2
C213	Ceramic, .05uf, +80 -20%, 100V	C50073-2
C214	Mylar, .0047uf, 400V	C50197-25
C215	Mica, 3900, 5%, 500V	C50332-6
C216, 217,		
218	Ceramic, .005uf, 20%, 500V	C50089-1
C219	Ceramic, 330, 1000V	C50072-1
C220	Ceramic, .005uf, 20%, 500V	C50089-1
C221, 222	Ceramic, .02uf, +80 -20%, 500V	C50089-4
C223, 224	Ceramic, .001uf, 1000V	C50072-3
C225, 226	Ceramic, 2200, 1000V	C50072-5

RESISTORS AND POTENTIOMETERS

In ohms, 10% tolerance, 1/2 Watt, unless otherwise noted. K=Kilohm, M=Megohm.

Symbol	Description	Part No.
R200	Composition, 22M	RC20BF226K

R201	Composition, 4.7K, 5%	RC20BF742J
R202	Composition, 15K, 5%	RC20BF135J
R203	Composition, 10M	RC20BF106K
R204	Dep. Carbon, 1M, 5%, 1/3 W	R33DC105J
R205	Dep. Carbon, 330K, 5%, 1/3 W	R33DC334J
R206	Dep. Carbon, 1M, 5%, 1/3 W	R33DC105J
R207	Dep. Carbon, 1.5M, 5%, 1/3 W	R33DC155J
R208	Dep. Carbon, 22K, 5%, 1/3 W	R33DC223J
R209, 210,		
211, 212	Composition, 33K, 5%	RC20BF333J
R213, 214	Dep. Carbon, 100K, 5%, 1/3 W	R33DC104J
R215	Potentiometer, 50K, MPX-separation	R50150-4
R216	Composition, 10M	RC20BF106K
R217, 218	Dep. Carbon, 18K, 5%, 1/3 W	R33DC183J
R219, 220	Dep. Carbon, 15K, 5%, 1/3 W	R33DC153J
R221	Composition, 10M	RC20BF106K
R222, 223,		
224, 225	Dep. Carbon, 22K, 5%, 1/3 W	R33DC223J
R226, 227,		
228, 229,		
230	Dep. Carbon, 1M, 5%, 1/3 W	R12DC105J

MISCELLANEOUS

Symbol	Description	Part No.
CR100, 101,		
102, 103	Diode, Type 1112	V-1112
L100	Coil, Low Pass	L50210-30
L101	Coil, 5.25, M.H., 5%	L50334-1
L102, 103	Coil, 20, M.H., 5%	L50334-2
Z100	Transformer, 19Kc	ZZ50210-34
Z101	Coil, 38Kc	ZZ50210-33

TUBE LAYOUT

*1" Tubes Replaced Jan 79
No markings - Some original tubes*

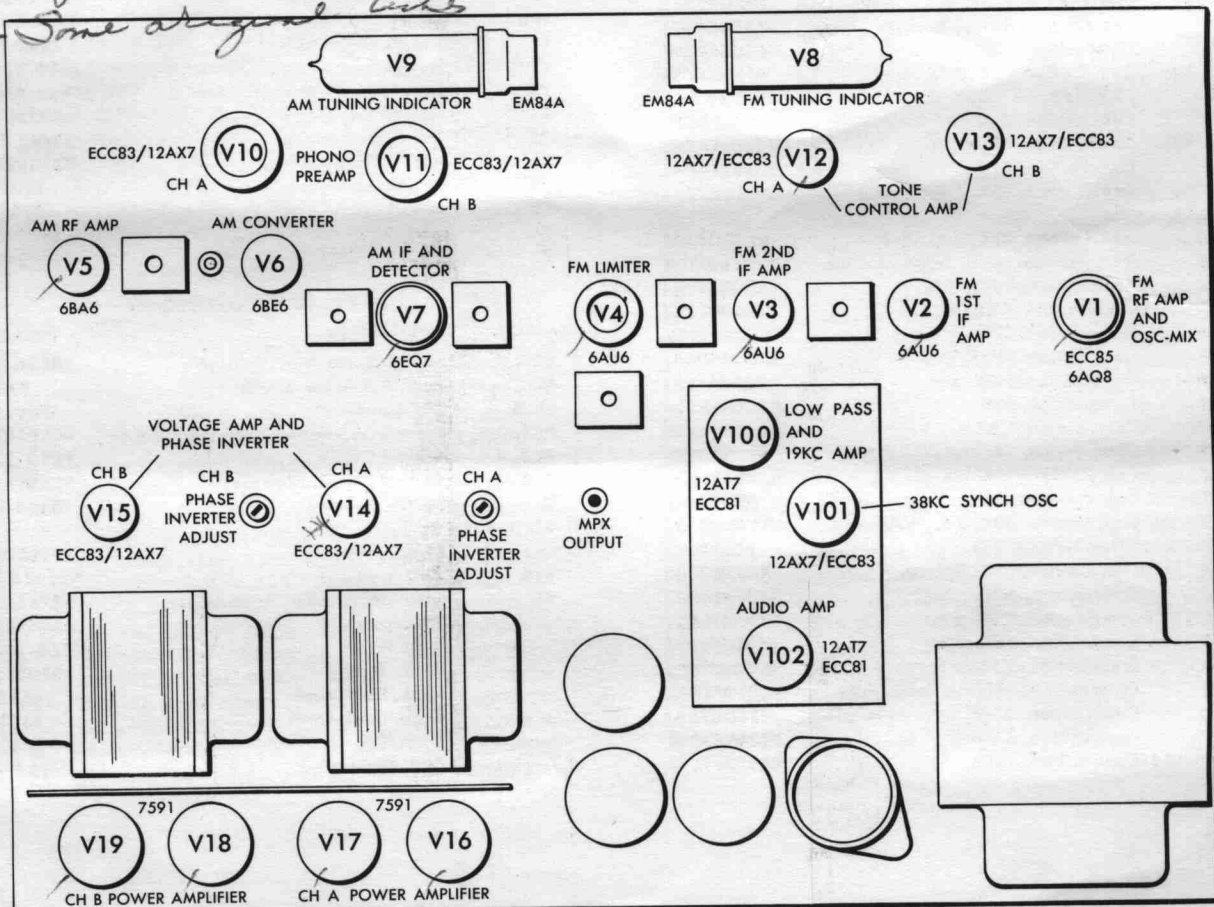

SCHEMATIC DIAGRAM

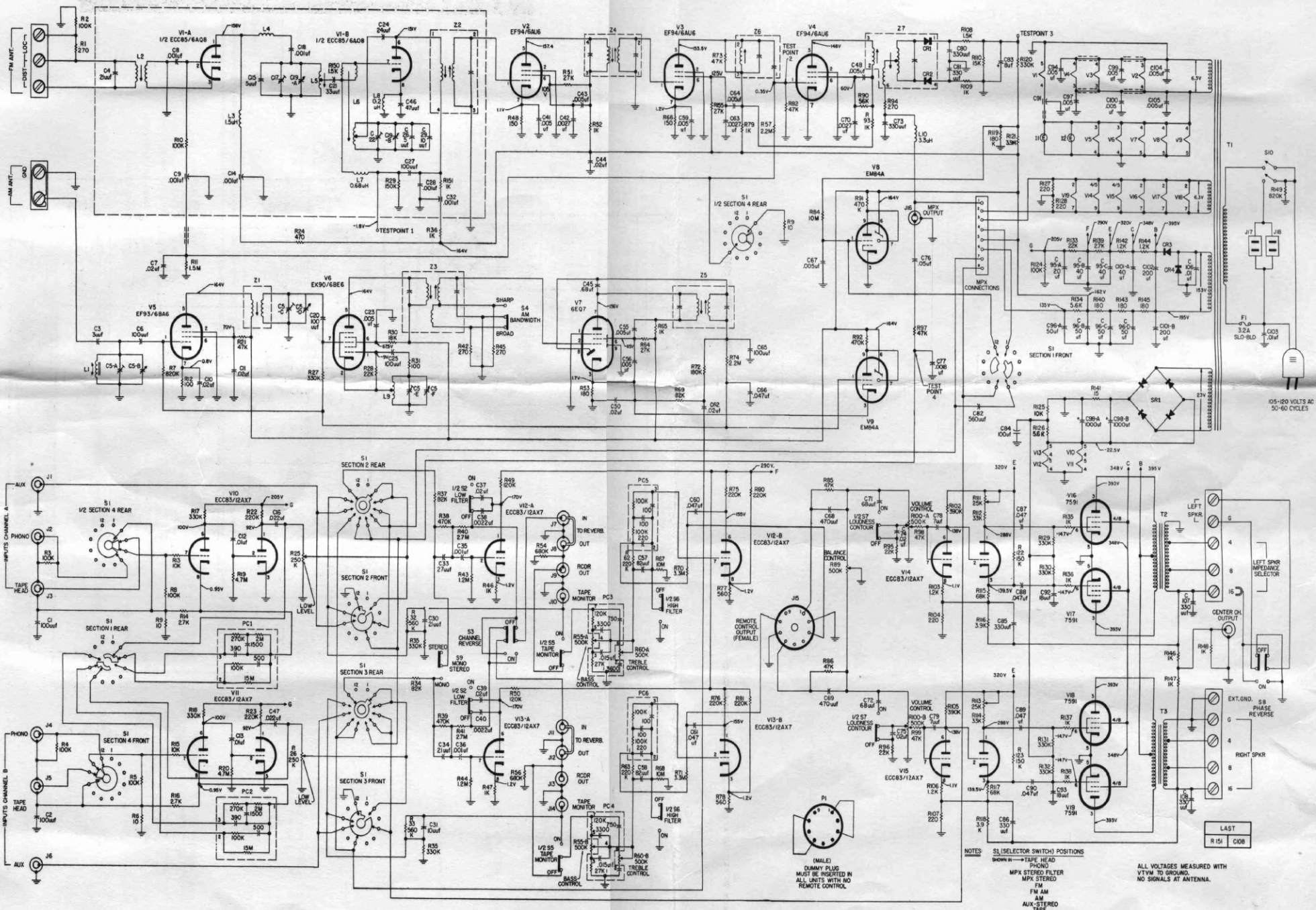

SCHEMATIC DIAGRAM • MULTIPLEX SECTION

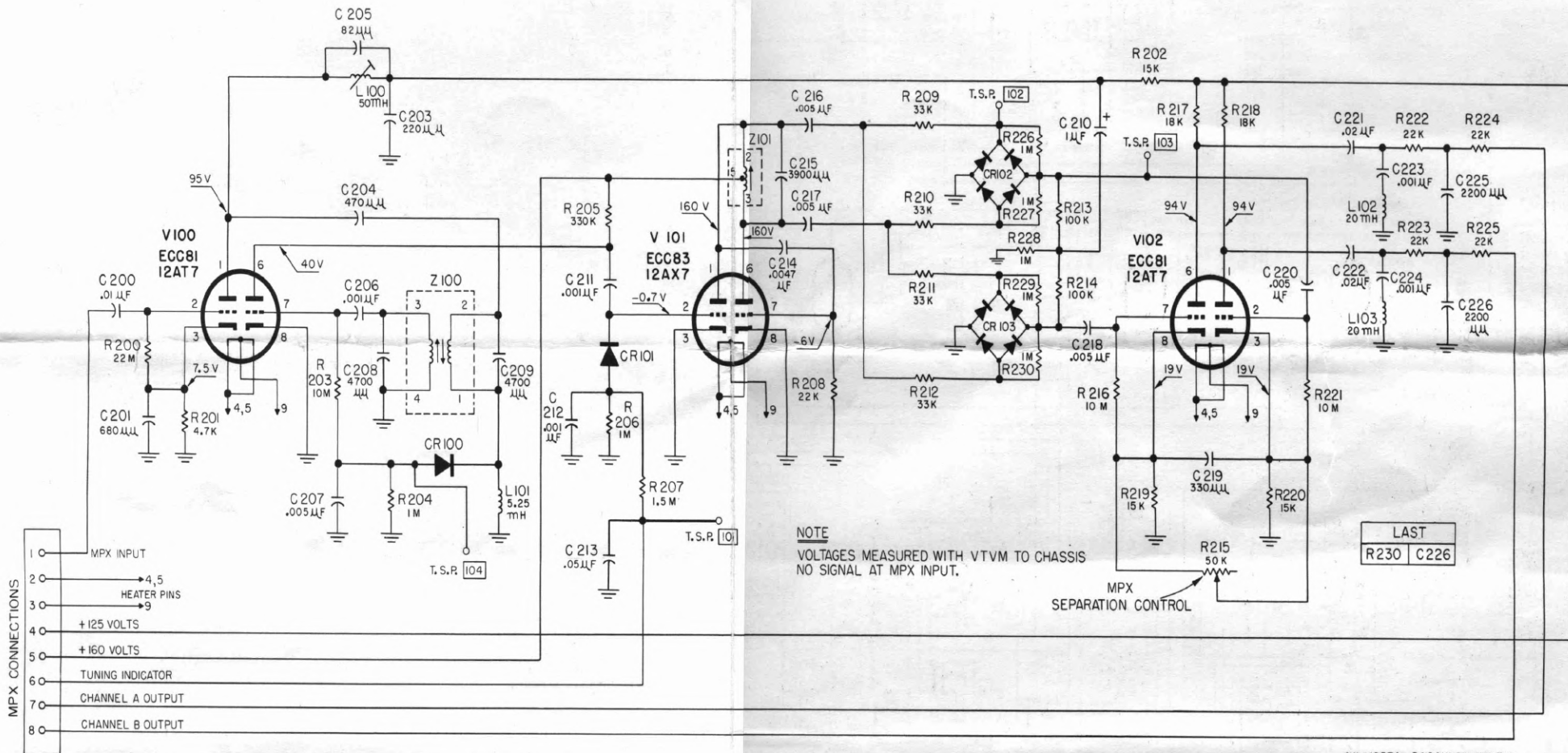

ALIGNMENT INSTRUCTIONS

Read These Instructions With Extreme Care Before Attempting Alignment.

CHASSIS: Turn the station selectors completely counterclockwise, without forcing. Dial pointers should be at zero index mark on logging scale. If not, reset the dial pointers. Disconnect the external antennas and the antenna link. Set Ferrite Loop to normal position, parallel to rear panel. When using an oscilloscope for alignment, set the output level controls for no overload, as shown by the proper waveform shape. Connect leads to main output and turn volume control to minimum.

SIGNAL GENERATORS: The signal generator equipment must be able to supply the following: FM RF modulated 30% (± 22.5 KC deviation) at 400 cps; AM RF modulated 30% at 400 cps;

AM IF with 30KC sweep for AM bandwidth adjustment.

INDICATOR: DC VTVM, AC VTVM, and scope for alignment.

ALIGNMENT: Allow the chassis and test instruments to warm up for at least fifteen minutes. Adjust the line voltage for 117 volts AC, 50-60 cycles. Use fully insulated tools: a small screwdriver for all trimming capacitors; a K-Tran tool for Z1, Z2, Z3, Z4, Z5; a hex tool for L2, L5, L6 Z6 and Z7. For AM alignment, short AVC to ground.

AM ALIGNMENT

STEPS	CHASSIS			SIGNAL GENERATOR				INDICATOR		ALIGNMENT	
	AM BANDWIDTH	SELECTOR	STATION SELECTOR	COUPLING	FREQ.	MOD.	TYPE	CONNECTION	ADJUST	INDICATION	
1	SHARP	AM	Point of no signal and no interference	AM Gen. connected thru .01-uf cap. in series with hot lead to V6, Pin 7	455 KC	30% AM at 400 cps	AC VTVM to Ch. B Rec. Output	Z3, Z5 top and bottom	Maximum voltage		
2	BROAD	AM	Point of no signal and no interference	AM Gen. connected thru .01-uf cap. in series with hot lead to V6, Pin 7	455 KC	30 KC sweep	Scope to Ch. B Rec. Output	Z5 bottom	Adjust slightly for symmetrical curve		
3	SHARP	AM	600 KC	AM Gen. connected thru 220-uf to the AM antenna terminal. Disconnect link between terminals.	600 KC	30% AM at 400 cps	AC VTVM to Ch. B Rec. Output	L9, Z1, L1	Maximum voltage		
4	SHARP	AM	1400 KC	AM Gen. connected thru 220-uf to the AM antenna terminal. Disconnect link between terminals.	1400 KC	30% AM at 400 cps	AC VTVM to Ch. B Rec. Output	C5E, C5C, C5A	Maximum voltage		
5	Repeat steps 3 and 4 for proper dial calibration and maximum output.										
6	FM	Point of no signal and no interference	FM Gen. connected to ungrounded tube shield of V1	10.7 MC	None	DC VTVM to test point 3	Z2, Z4, Z6 and Z7, top and bottom	Maximum negative voltage			
7	FM	Point of no signal and no interference	FM Gen. connected to ungrounded tube shield of V1	10.7 MC	None	Connect hot lead of DC VTVM to MPX output, ground to junction of resistors (47K) connected in series from TSP3 to GND.	Z7, top	Zero reading on zero center scale			
8	FM	90 MC	FM Gen. connected thru two 120-ohm carbon resistors in series with lead to antenna terminals DISTANCE.	90 MC	30% FM (22.5 KC Dev.) at 400 cps	DC VTVM to TSP3 and scope to Ch. A. Rec. output	L6, L5 and L2	Check for sine waveform and adjust for maximum negative voltage			
9	FM	106 MC	FM Gen. connected thru two 120-ohm carbon resistors in series with lead to antenna terminals DISTANCE.	106 MC	30% FM (22.5 KC Dev.) at 400 cps	DC VTVM to TSP3 and scope to Ch. A. Rec. output	C22, C17	Check for sine waveform and adjust for maximum negative voltage			
10	Repeat steps 8 and 9 for proper dial calibration and maximum output.										

FM ALIGNMENT

SERVICE NOTES



FISHER RADIO CORPORATION • NEW YORK



N860-104BX

PRINTED IN U. S. A.

©1961 FISHER RADIO CORPORATION

333-W12C-121