

CDP-C301M/C305M

SERVICE MANUAL



Photo: CDP-C305M

US Model
CDP-301M
AEP Model
UK Model
CDP-C301M/305M
E Model
CDP-305M

For Service Manuals Contact
MAURITRON TECHNICAL SERVICES
8 Cherry Tree Rd, Chinnor
Oxon OX9 4QY
Tel:- 01844-351694 Fax:- 01844-352554
Email:- enquiries@mauritron.co.uk

Model Name Using Similar Mechanism	CDP-C500M
Base Unit Name	BU-5C/BU-5M

SPECIFICATIONS

	CDP-C305M	CDP-C301M
System	Compact disc digital audio system	
Laser	Semiconductor laser ($\lambda = 780 \text{ nm}$) Emission duration: continuous	
Laser output	Max. $44.6 \mu\text{W}^*$ * This output is the value measured at a distance of about 200 mm from the objective lens surface on the Optical Pick-up Block.	
Frequency response	2 Hz - 20 kHz ($\pm 1.0_{-1.2}^0 \text{ dB}$)	
Signal to noise ratio	More than 93 dB	
Dynamic range	More than 90 dB	
Harmonic distortion	Less than 0.05% (1 kHz)	
Channel separation	More than 90 dB (1 kHz)	
Wow and flutter	Below measurable limit	
Outputs	Output level 2 V (at 50 kilohms) Load impedance over 10 kilohms	
LINE OUT (phono jacks)		
HEADPHONES (stereo phone jack)	Output level 0 - 10 mW (variable) (at 32 ohms)	

General

Power requirements	US model: 120 V AC, 60 Hz UK, Australian model: 240 V AC, 50/60 Hz AEP model: 220 V AC, 50/60 Hz E model: 110 - 120 or 220 - 240 V AC adjustable, 50/60 Hz
Power consumption	11 W
Dimensions (not including projecting parts and controls)	Approx. 355 × 110 × 385 mm (w/h/d) (14 × 4 $\frac{1}{8}$ × 15 $\frac{1}{4}$ inches)
Weight	Approx. 5.0 kg (11 lbs)

Supplied accessories

	CDP-C305M	CDP-C301M
Audio signal connecting cord	1 (phono plug × 2 ↔ phono plug × 2)	
AC plug adaptor	1 (for other countries and EC only)	
Remote commander	1	
R6 (size AA) batteries	2	

Design and specifications subject to change without notice.



COMPACT DISC PLAYER
SONY®

TABLE OF CONTENTS

Section	Title	Page
Specifications		1
Safety Check-out		2
1. SERVICING NOTES		
Front Panel Assembly Removing		3
Notes on Handling the Optical Pick-up Block or Base Unit		3
Notes on Laser Diode Emission Check		3
Laser Diode and Focus Search Operation Check		3
Notes on the Transit Key		3
Protection of Eyes from Laser Beam during Servicing		4
2. GENERAL		5
3. ELECTRICAL ADJUSTMENTS		6
4. DIAGRAMS		
4-1. Block Diagram		8
4-2. Printed Wiring Boards		11
4-3. Schematic Diagram		15
5. EXPLODED VIEWS		19
6. ELECTRICAL PARTS LIST		23

MODEL IDENTIFICATION

- Specification Labels -

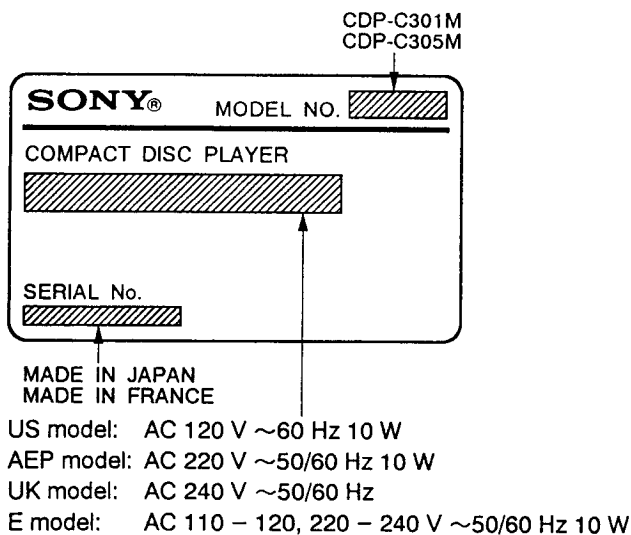

SAFETY-RELATED COMPONENT WARNING!!

COMPONENTS IDENTIFIED BY MARK OR DOTTED LINE WITH MARK ON THE SCHEMATIC DIAGRAMS AND IN THE PARTS LIST ARE CRITICAL TO SAFE OPERATION. REPLACE THESE COMPONENTS WITH SONY PARTS WHOSE PART NUMBERS APPEAR AS SHOWN IN THIS MANUAL OR IN SUPPLEMENTS PUBLISHED BY SONY.

SAFETY CHECK-OUT

After correcting the original service problem, perform the following safety check before releasing the set to the customer:

Check the antenna terminals, metal trim, "metallized" knobs, screws, and all other exposed metal parts for AC leakage. Check leakage as described below.

LEAKAGE TEST

The AC leakage from any exposed metal part to earth ground and from all exposed metal parts to any exposed metal part having a return to chassis, must not exceed 0.5 mA (500 microampers). Leakage current can be measured by any one of three methods.

1. A commercial leakage tester, such as the Simpson 229 or RCA WT-540A. Follow the manufacturers' instructions to use these instruments.
2. A battery-operated AC milliammeter. The Data Precision 245 digital multimeter is suitable for this job.
3. Measuring the voltage drop across a resistor by means of a VOM or battery-operated AC voltmeter. The "limit" indication is 0.75 V, so analog meters must have an accurate low-voltage scale. The Simpson 250 and Sanwa SH-63Trd are examples of a passive VOM that is suitable. Nearly all battery operated digital multimeters that have a 2V AC range are suitable. (See Fig. A)

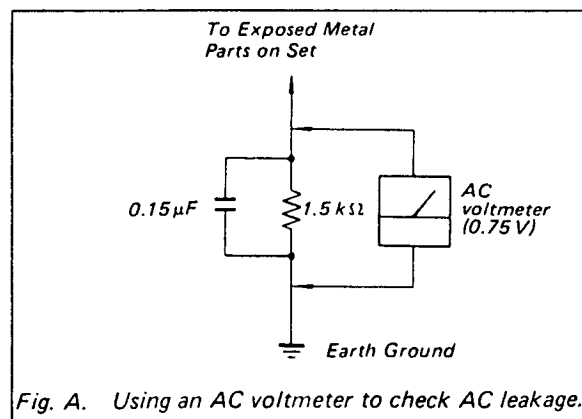

ATTENTION AU COMPOSANT AYANT RAPPORT À LA SÉCURITÉ!

LES COMPOSANTS IDENTIFIÉS PAR UNE MARQUE SUR LES DIAGRAMMES SCHÉMATIQUES ET LA LISTE DES PIÈCES SONT CRITIQUES POUR LA SÉCURITÉ DE FONCTIONNEMENT. NE REMPLACER CES COMPOSANTS QUE PAR DES PIÈCES SONY DONT LES NUMÉROS SONT DONNÉS DANS CE MANUEL OU DANS LES SUPPLÉMENTS PUBLIÉS PAR SONY.

SECTION 1 SERVICING NOTES

Front Panel Assembly Removing

Note: Follow the disassembly procedure in the numerical order given.

When the power can be supplied

- ① Unscrew 6 stopper screws and remove the upper cover.
- ② Turn the power on.
- ③ Push OPEN/CLOSE button and open the disc table.

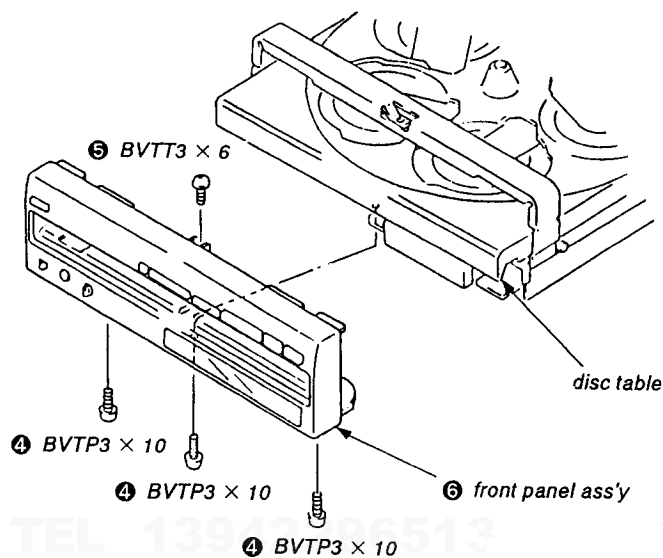

When the power cannot be supplied

- ① Unscrew 6 stopper screws and remove the upper cover.
- ③ Perform items ④ to ⑥ of "When the power can be supplied."

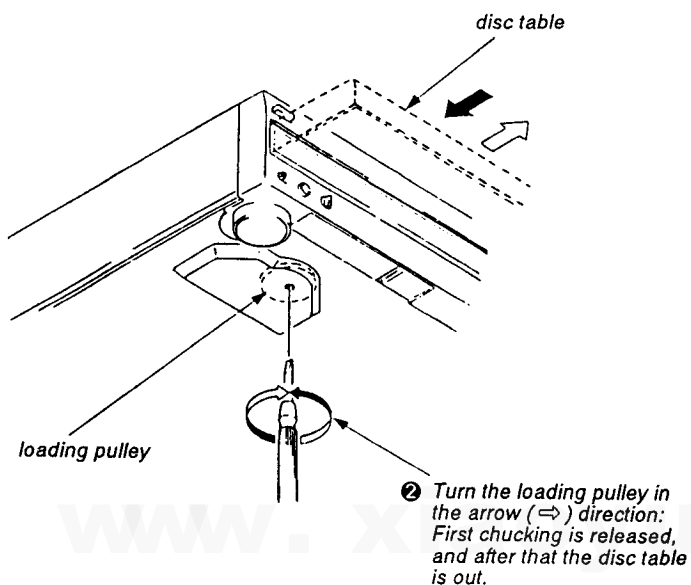

- ② Turn the loading pulley in the arrow (\Rightarrow) direction: First chucking is released, and after that the disc table is out.

NOTES ON HANDLING THE OPTICAL PICK-UP BLOCK OR BASE UNIT

The laser diode in the optical pick-up block may suffer electrostatic breakdown because of the potential difference generated by the charged electrostatic load, etc. on clothing and the human body. During repair, pay attention to electrostatic breakdown and also use the procedure in the printed matter which is included in the repair parts. The flexible board is easily damaged and should be handled with care.

NOTES ON LASER DIODE EMISSION CHECK

The laser beam on this model is concentrated so as to be focused on the disc reflective surface by the objective lens in the optical pick-up block. Therefore, when checking the laser diode emission, observe more than 30 cm away from the objective lens.

[Laser Diode and Focus Search Operation Check]

When turning on the power with no disc, confirm the following operation.

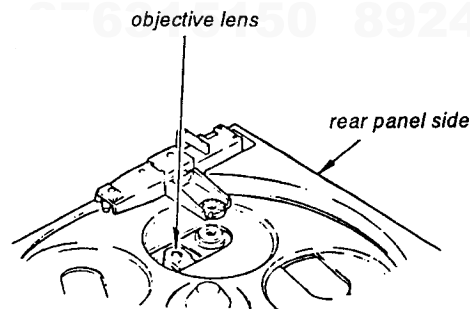

- ① Confirm the laser beam is spread.
- ② The objective lens moves up and down once.

Note on the Transit Key

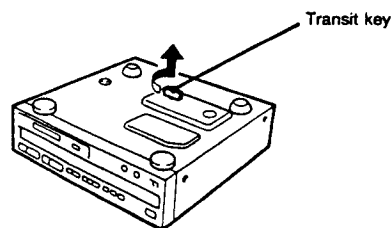

The white transit key on the bottom exterior of the unit protects the optical system against shock during transportation. Before operating the CD player, be sure to remove the key by following the instructions on the label, and store it in a safe place.

When transporting the unit, replace the key in its original hole and lock it in place.

PROTECTION OF EYES FROM LASER BEAM DURING SERVICING

This set employs a laser. Therefore, be sure to follow carefully the instructions below when servicing.

CAUTION

Use of controls or adjustments or performance of procedures other than those specified herein may result in hazardous radiation exposure.

1. Laser Diode Properties

- Material: GaAlAs
- Wavelength: 780 nm
- Emission Duration: continuous
- Laser Output: max. 44.6 μ W*

* This output is the value measured at a distance of about 200 mm from the objective lens surface on the Optical Pick-up Block.

2. During service, do not take the Optical Pick-up Block apart, and do not adjust the APC circuit. If there is a breakdown in the APC circuit (including laser diode), replace the entire Optical Pick-up Block (including APC board).

BESKYTTELSE AF ØJNE MOD LASERSTRÅLING UNDER SERVICE

I dette apparat anvendes laserlys. Derfor skal nedenstående instruktioner nøje følges under service.

Følg iøvrigt instruktionerne i servicemanualen.

ADVARSEL!!

Under service må øjnene ikke komme nær objektiv-linsen på den optiske pick-up enhed. I tilfælde af at det er nødvendigt at kontrollere udsendelsen af laserlys, skal det ske i en afstand af mere end 25 cm fra den optiske pick-up.

1. Laser-dioe data

- Materiale: GaAlAs
- Bølgelængde: 780 nm
- Udstråling: Kontinuerlig
- Laseroutput: Max. 0,4 mW*

* Målt i 1,6 mm afstand fra overfladen af objektiv-linsen på den optiske pick-up enhed.

- Klassifikation: Klasse IIIb.

2. Adskil aldrig den optiske pick-up enhed under service, og juster ikke APC kredsløbet (Automatic Power Control). Hvis APC kredsløbet (incl. laserdioden) bryder ned, skal hele den optiske pick-up enhed (incl. APC printkortet) udskiftes.

LASER ADVARSEL MÆRKNING

Følgende mærkning findes indvendig i apparatet:

1. Advarsel Mærkning

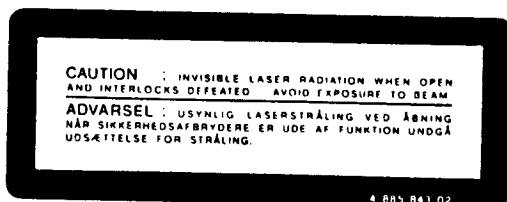

VAROITUS: Laite sisältää, laserdiodin, joka lähettää (näkyvätöntä) silmille vaarallista lasersäteilyä.

SECTION 2 GENERAL

QQ 376315150 892498299

CDP-C305M

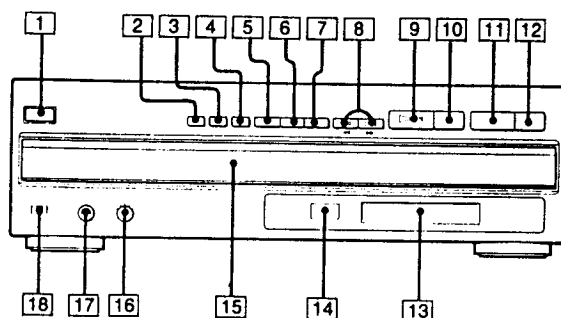

- 1 POWER switch
- 2 TIME button
- 3 REPEAT button
- 4 TIME FADE button
- 5 CONTINUE button
- 6 SHUFFLE button
- 7 PROGRAM button
- 8 <<<<<>>>> (AMS*/RMS*/manual search) buttons
- 9 >>>> (play/pause) button
- 10 ■ (stop) button

- 11 ▲ OPEN/CLOSE button
- 12 DISC SKIP button
- 13 Display window
- 14 Remote sensor
- 15 Disc tray
- 16 (Headphones) LEVEL control (CDP-C305M only)
- 17 HEADPHONES jack (CDP-C305M only)
- 18 TIMER switch

* AMS is the abbreviation of Automatic Music Sensor.
 ** RMS is the abbreviation of Random Music Sensor.

TEL 13942296513 QQ 376315150 892498299

RM-D306 (CDP-C305M)

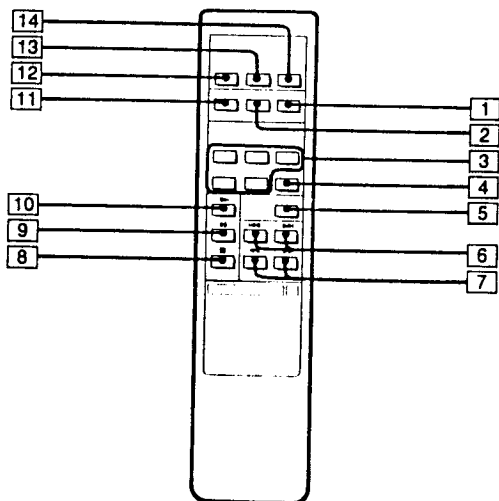

- 1 MUSIC SCAN button
- 2 REPEAT button
- 3 DISC 1 - 5 buttons
- 4 DISC SKIP button
- 5 FADER button
- 6 <<<>>> (AMS) buttons
- 7 <<>> (manual search) buttons
- 8 ■ (stop) button
- 9 >>> (pause) button
- 10 >>> (play) button
- 11 TIME button
- 12 CONTINUE button
- 13 SHUFFLE button
- 14 PGM (program) button

TEL 13942296513 QQ 376315150 892498299

TEL 13942296513 QQ 376315150 892498299

SECTION 3 ELECTRICAL ADJUSTMENTS

1. Perform adjustments in the order given.
2. Use YEDS-18 (Part No: 3-702-101-01) disc unless otherwise indicated.
3. Use the oscilloscope with more than 10 MΩ impedance.

RF PLL Free Run Frequency Adjustment/Lock Frequency Check

Procedure :

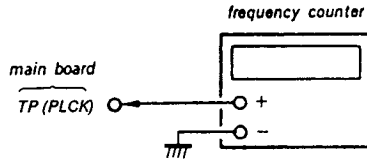

1. Put the set into test mode.
2. Connect test point TP (ASY) to ground with lead wire.
3. Turn POWER switch on.
4. Connect the frequency counter to test point TP (PLCK).
5. Adjust RV5 so that the reading on frequency counter is 4.3218 MHz ±30 kHz.
..... (RF PLL frequency adjustment)
6. Remove lead wire connecting TP (ASY) to ground.
7. Set disc (YEDS-18) and press ▷ PLAY button.
8. Confirm that the reading on frequency counter is 4.3218 MHz.
..... (Lock frequency check)
9. Turn POWER switch off.

E-F Balance Adjustment

This adjustment should be made when replacing TOP (T-type Optical Pick-up).

Procedure :

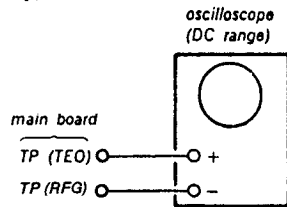

1. Put the set into test mode.
2. Connect test point TP (TES) and TP (ADJ) to ground with lead wire.
3. Connect oscilloscope to test point TP (TEO) and test point TP (RFG).
4. Set disc (YEDS-18) and turn POWER switch on.
5. Adjust RV1 so that the traverse waveform is symmetrical above and below.
6. Turn POWER switch off.
7. After adjustment, remove the lead wire connected in step 2.

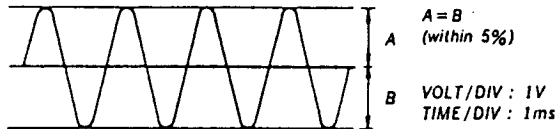

Focus Bias Adjustment

This adjustment should be made when replacing TOP (T-type Optical Pick-up).

Procedure :

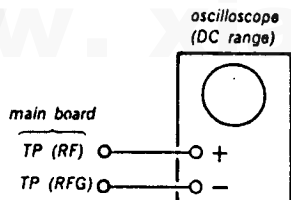

1. Put the set into test mode.
2. Connect oscilloscope to test point TP (RF) and test point TP (RFG).
3. Set disc (YEDS-18) and turn POWER switch on.
4. Adjust RV2 for an optimum waveform eye pattern or so that the peak is maximum. Optimum eye pattern means that shape "◇" can be clearly distinguished at the center of the waveform.
5. Turn POWER switch off.

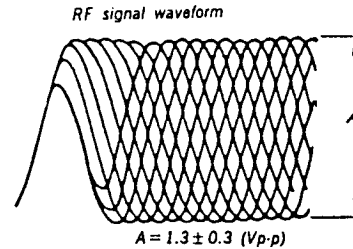

REFERENCE

Focus/Tracking Gain Adjustments

A frequency response analyzer is necessary in order to perform this adjustment exactly.

However, this gain has a margin, so even if it is slightly off, there is no problem. Therefore, do not perform this adjustment.

Focus/tracking gain determines the pick-up follow up (vertical and horizontal) relative to mechanical noise and shock when the 2-axis device operate.

However, as these reciprocate, the adjustment is at the point where both are satisfied.

- When gain is raised, the noise when the 2-axis device operates increases.
- When gain is lowered, mechanical shock and skipping occurs more easily.
- When gain adjustment is off, the symptoms below appear.

	Gain	Focus	Tracking
Symptoms			
• The time until music starts becomes longer for ■ STOP → ▷ PLAY or automatic selection. (◀◀, ▶▶ buttons pressed.) (Normally takes about 1 seconds.)		low	low or high
• Music does not start and disc continues to rotate for ■ STOP → ▷ PLAY or automatic selection. (◀◀, ▶▶ buttons pressed.)		—	low
• Sound is interrupted during PLAY or time counter display stops progressing.		—	low
• More noise during 2-axis device operation.	high		high

The following is a simple adjustment method.

Primary Adjustment

Note: Since exact adjustment cannot be performed, remember the positions of the controls before performing the adjustment. If the position after the primary adjustment are only a little different, return the controls to the original position.

Procedure:

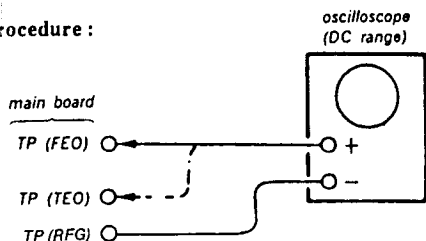

1. Keep the set horizontal.
(If the set is not horizontal, this adjustment cannot be performed due to the gravity against the 2-axis device.)
2. Put the set into test mode.
3. Set disc (YEDS-18) and turn POWER switch on.
4. Connect oscilloscope to main amp board TP (FEO).
5. Adjust RV3 so that the waveform is as shown in the figure below. (focus gain adjustment)

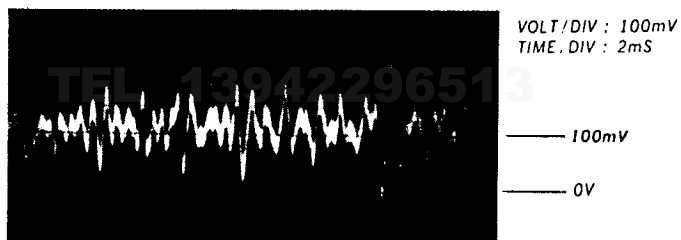

• Incorrect Examples (DC level changes more than on adjusted waveform)

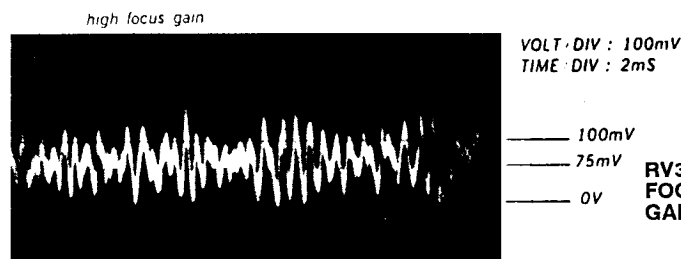
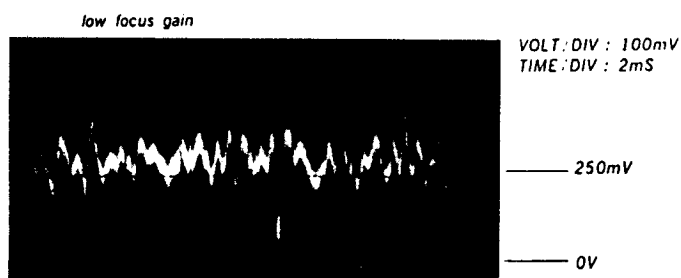

6. Connect oscilloscope to main board TP (TEO).
7. Adjust RV4 so that the waveform is as shown in the figure below. (tracking gain adjustment)
8. Turn POWER switch off.

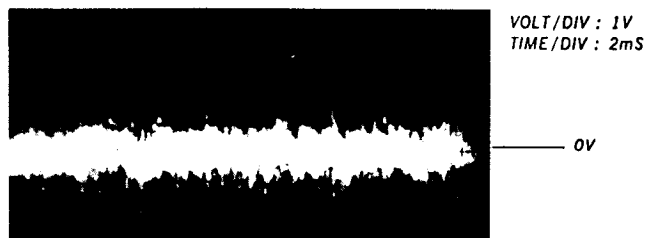

• Incorrect Examples (fundamental wave appears)

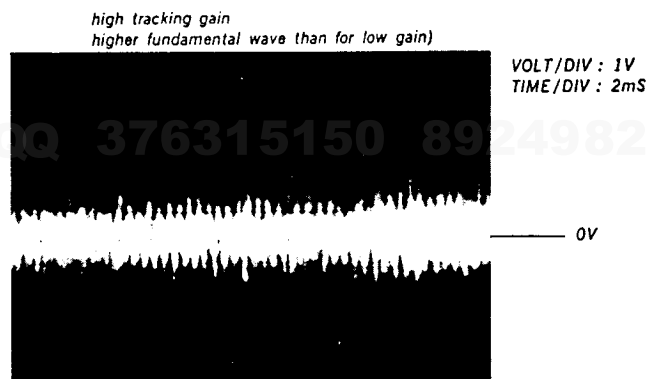
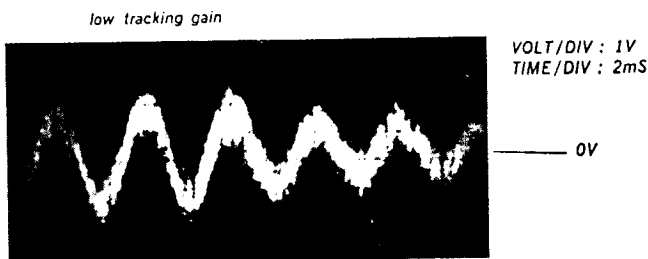

Adjustment Location: main board

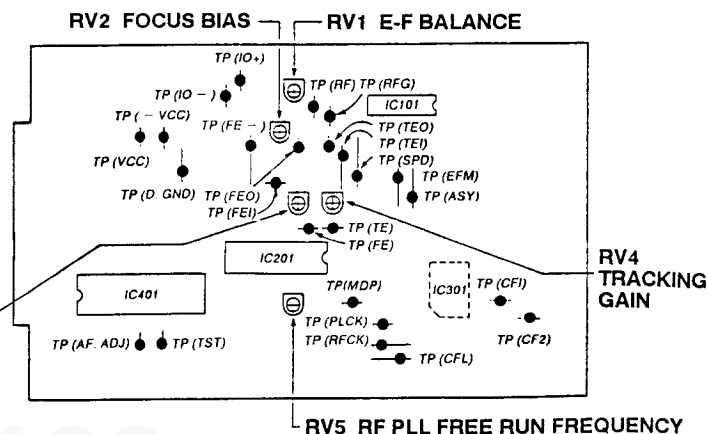

SECTION 4 DIAGRAMS

4-1. BLOCK DIAGRAM

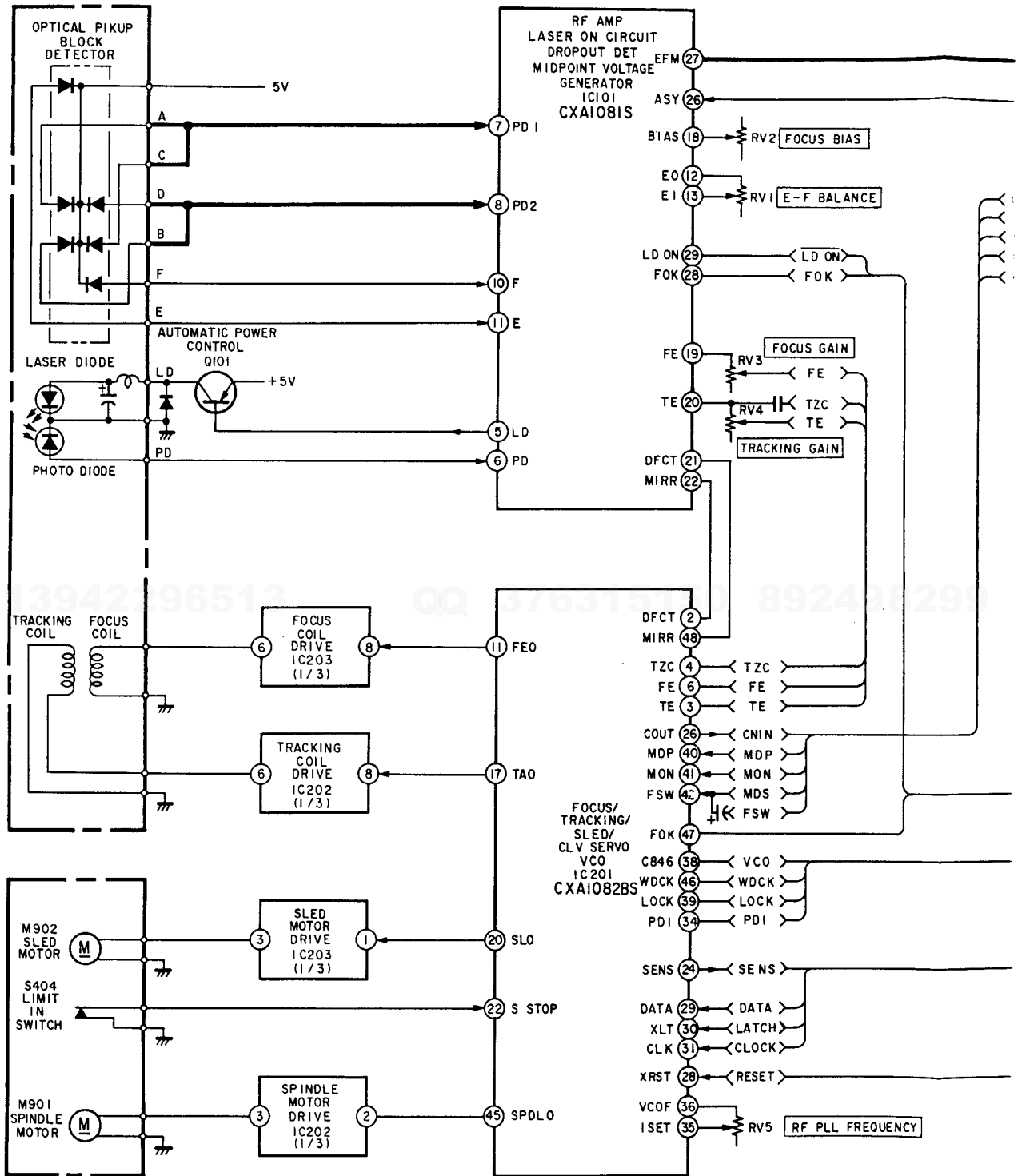

SECTION 4 DIAGRAMS

QQ 376315150 892498299

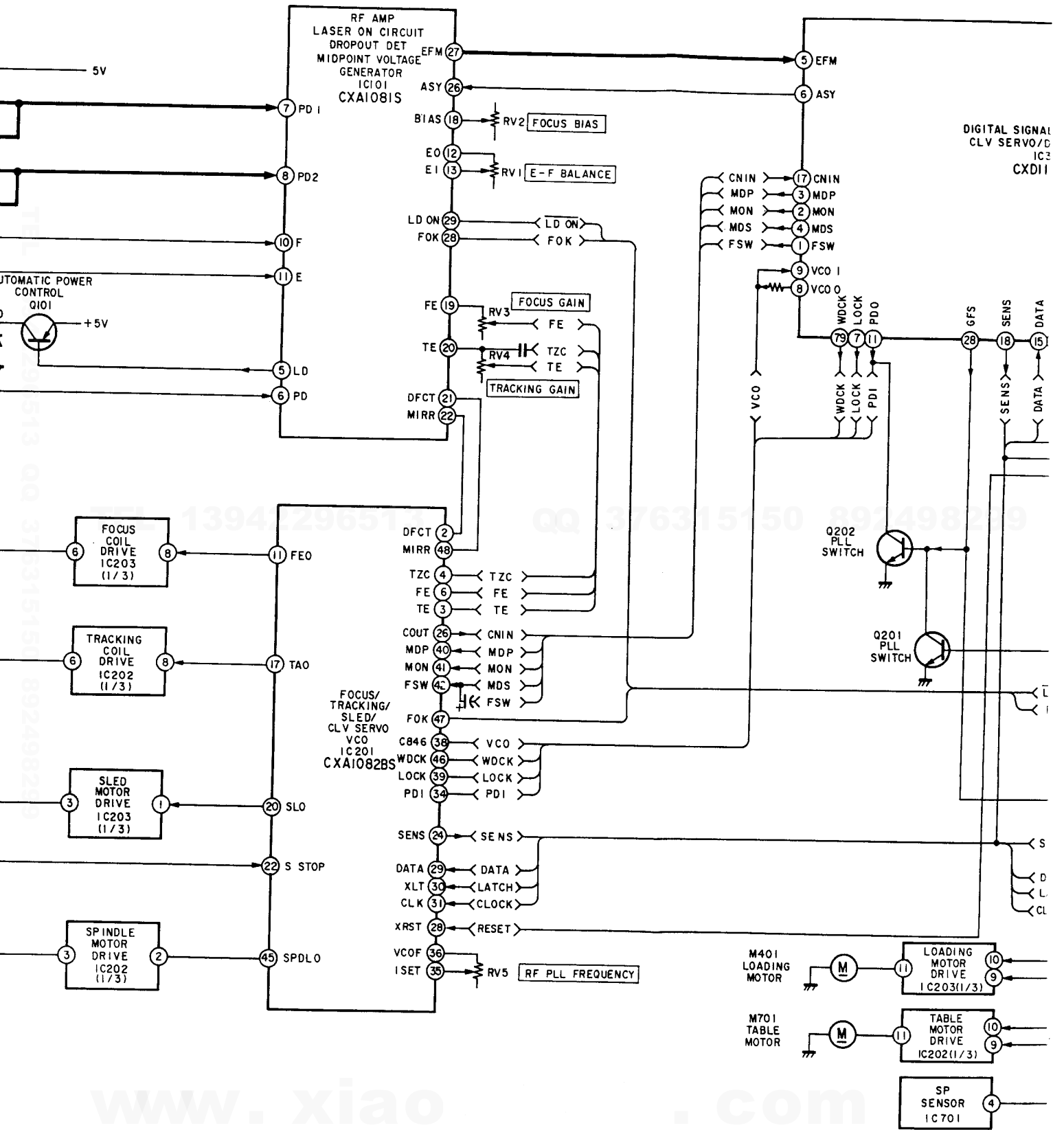

QQ 376315150 892498299

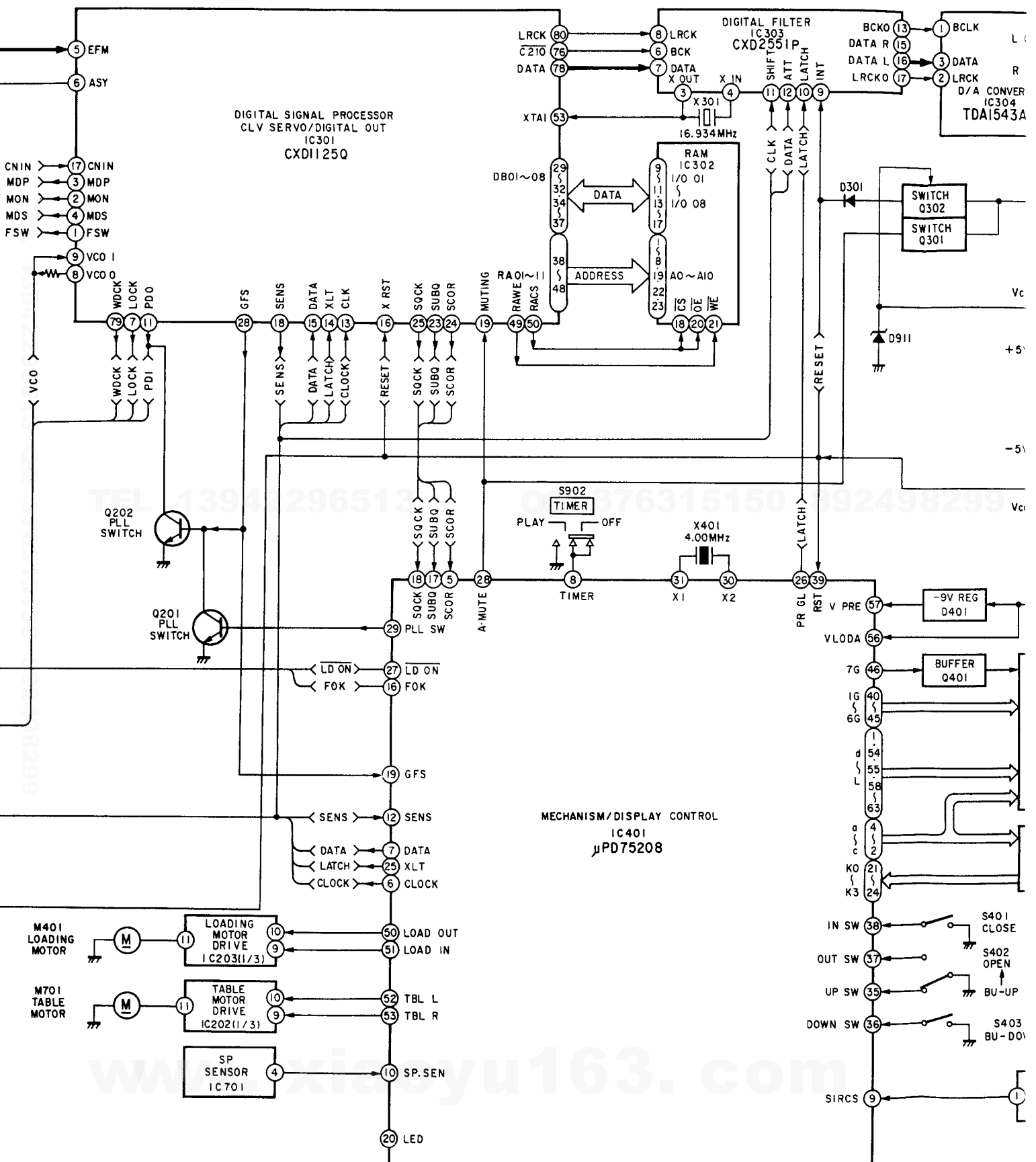

QQ 376315150 892498299

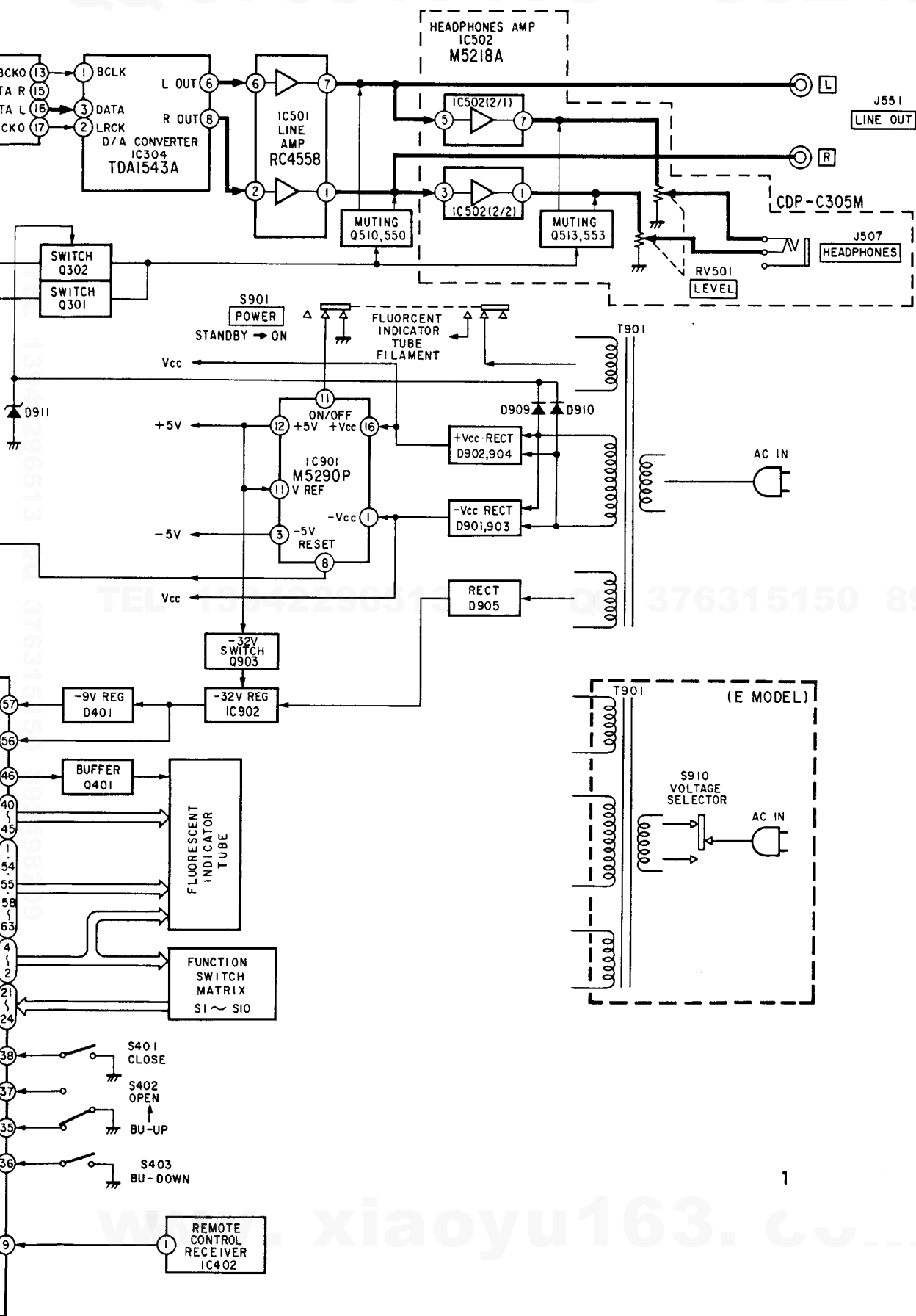

376315150 892498299

4-2. PRINTED WIRING BOARDS

• Circuit Boards Location

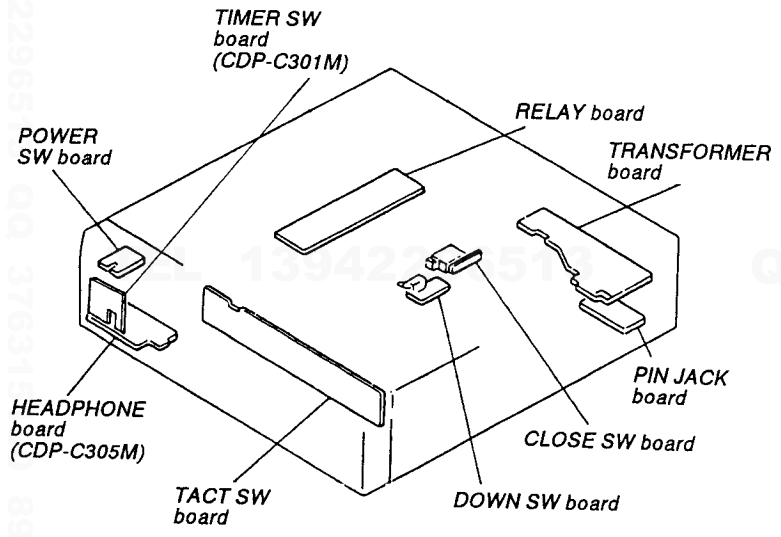
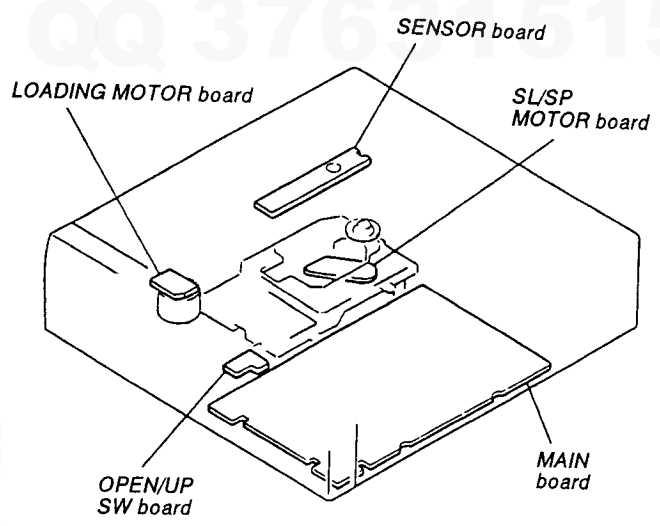

• Semiconductor Location

Ref. No.	Location	Ref. No.	Location
D101	D-14	IC401	G-17
D301	H-10	IC402	D-19
D402	I-18	IC501	I-10
D403	I-18	IC502	H-9
D404	I-19	IC701	I-26
D901	D-11	IC901	E-11
D902	D-10	IC902	F-9
D903	D-11		
D904	D-10	Q101	D-14
D905	E-9	Q201	H-15
D907	F-9	Q202	H-15
D909	D-9	Q301	I-10
D910	D-9	Q302	I-10
D911	G-9	Q401	G-16
		Q510	I-9
IC101	D-12	Q513	G-9
IC202	G-14	Q550	I-9
IC202	D-16	Q553	G-9
IC203	D-15	Q901	E-11
IC301	G-12	Q902	E-10
IC302	G-11	Q903	F-10
IC303	I-12		
IC304	I-11		

Note:
 • ○ : parts extracted from the component side.
 • ■ : parts mounted on the conductor side.
 • □ : indicates side identified with part number.

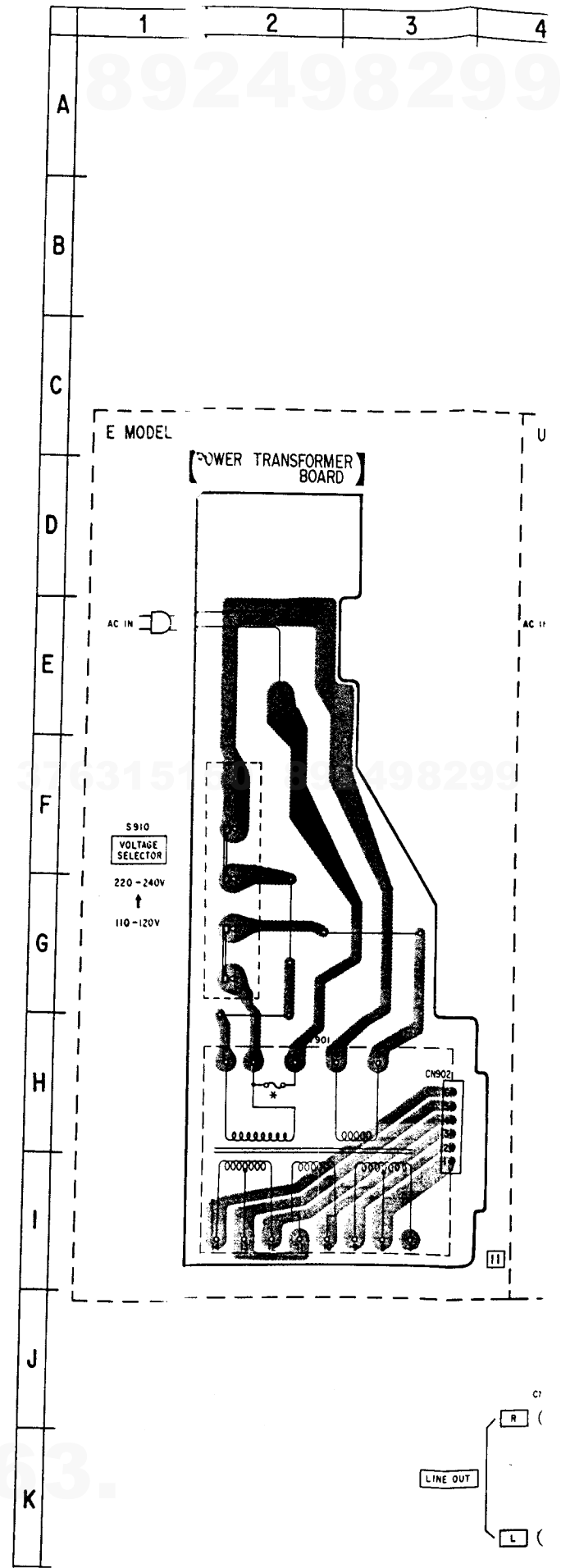

2 3 4 5 6 7 8 9 10

OPTICAL PICKUP BLOCK (KSS-150A)

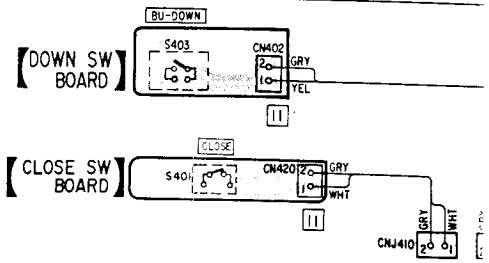
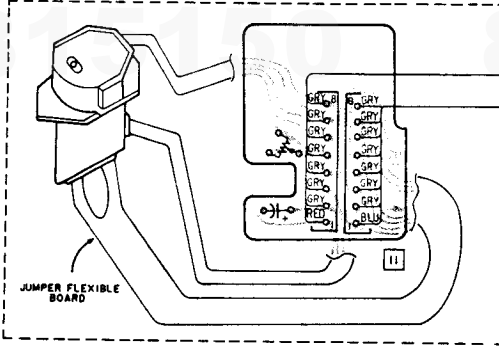

[MAIN BOARD]

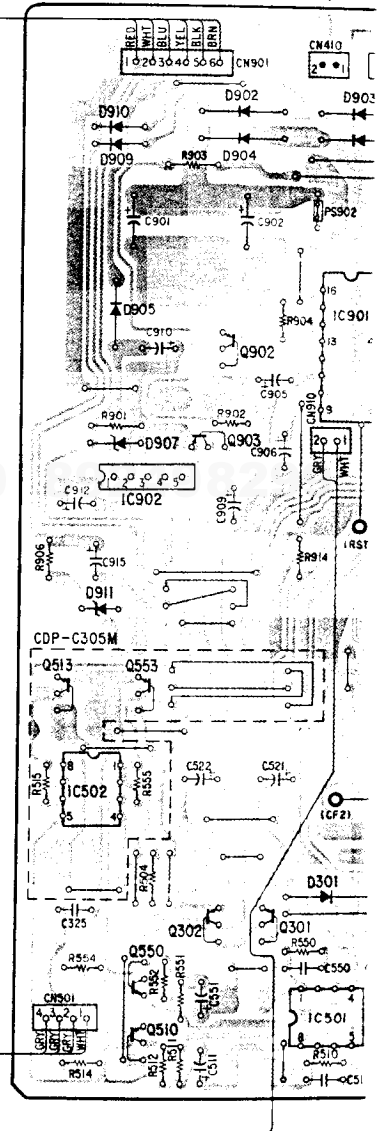

POWER TRANSFORMER BOARD

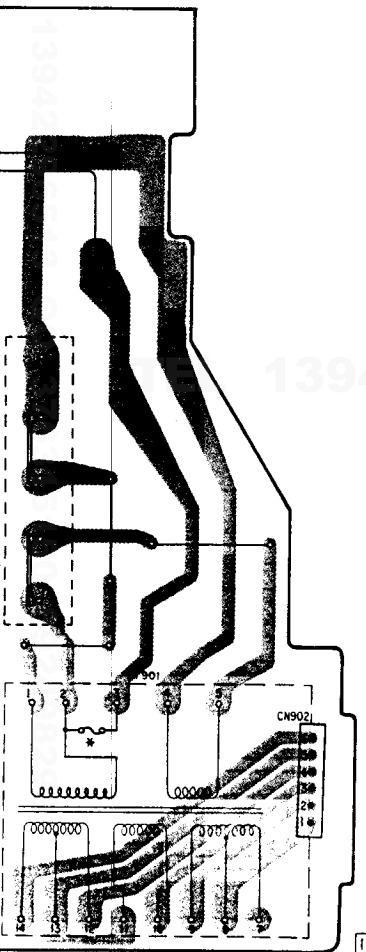

US, AEP, UK, AUSTRALIAN MODEL

[POWER TRANSFORMER BOARD]

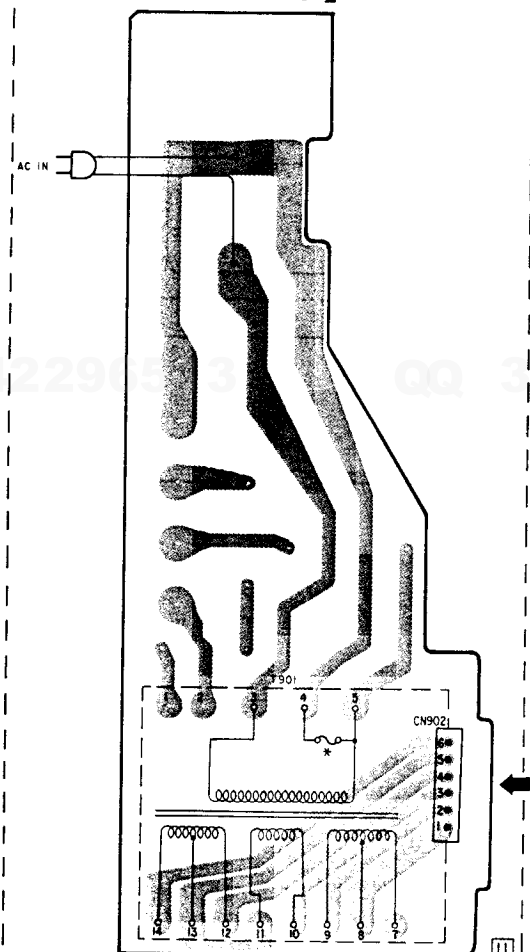

1394229 503 QQ 376315150

[PIN JACK BOARD]

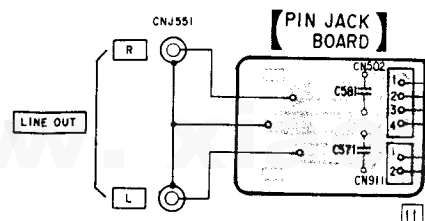

[TACT SW BOARD]

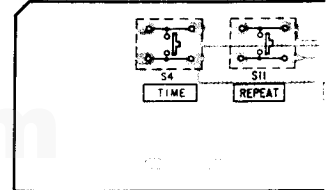

8 9 10 11 12 13 14 15 16

[DOWN SW BOARD]

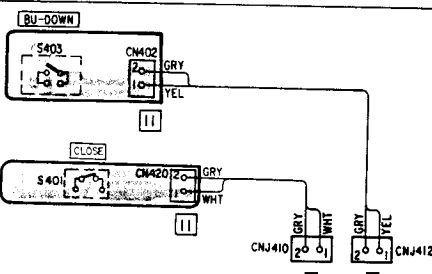

[CLOSE SW BOARD]

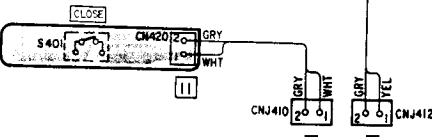

[SL/SP MOTOR BOARD]

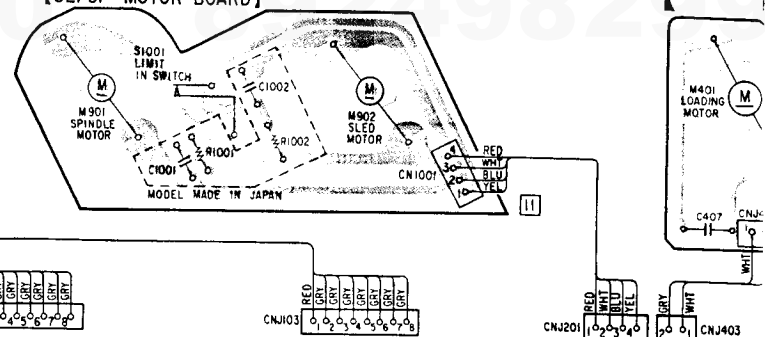

[MAIN BOARD]

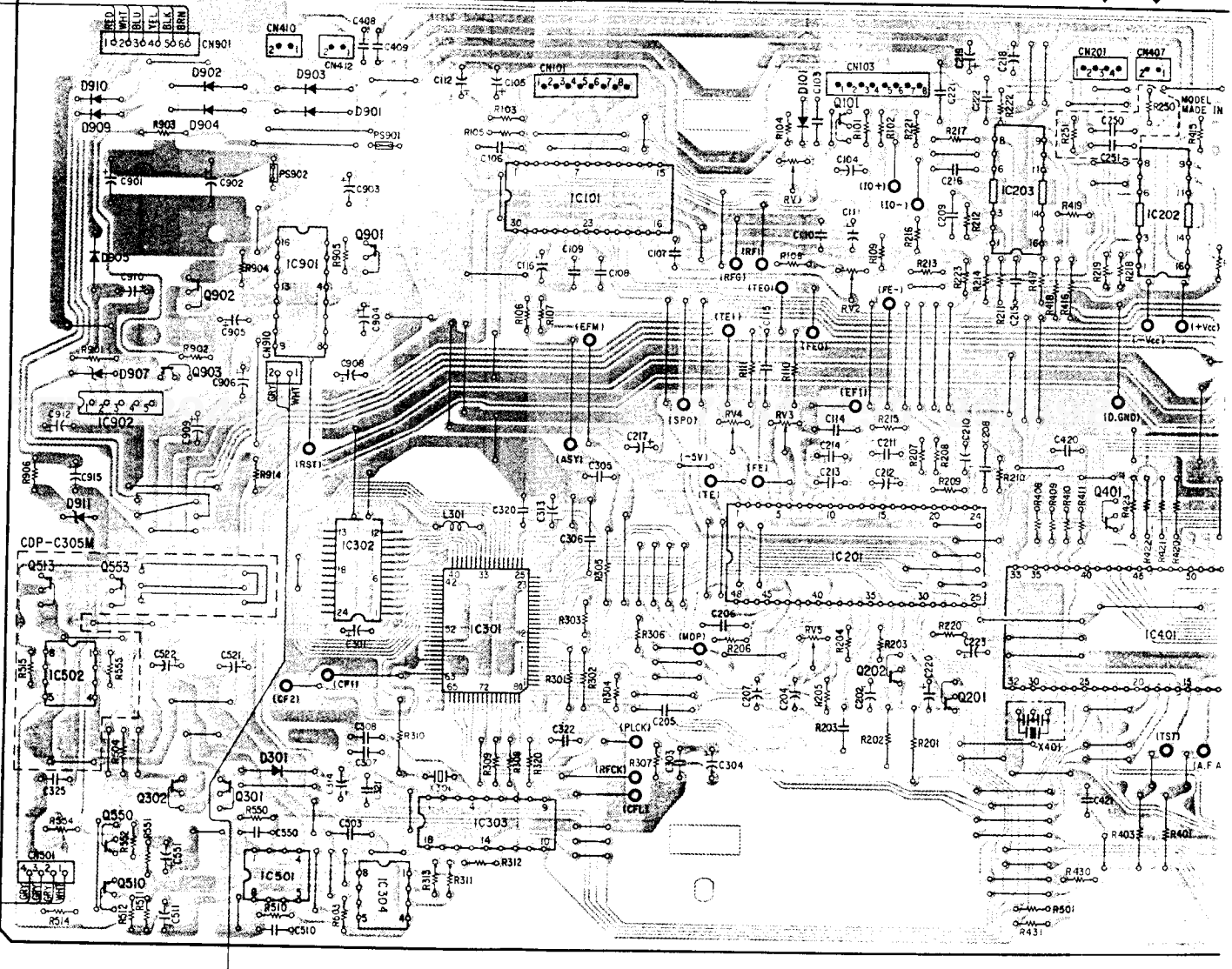

[TACT SW BOARD]

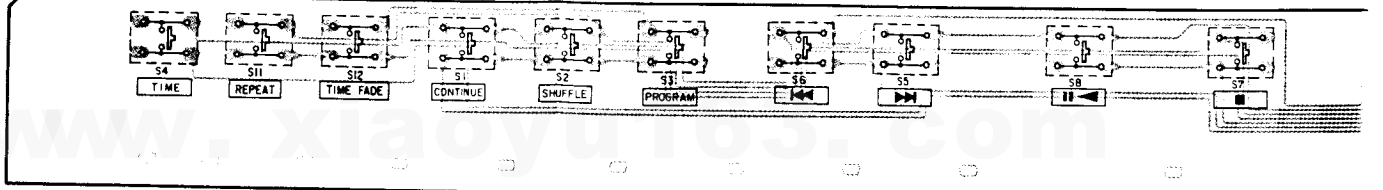

14 15 16 17 18 19 20 21 22

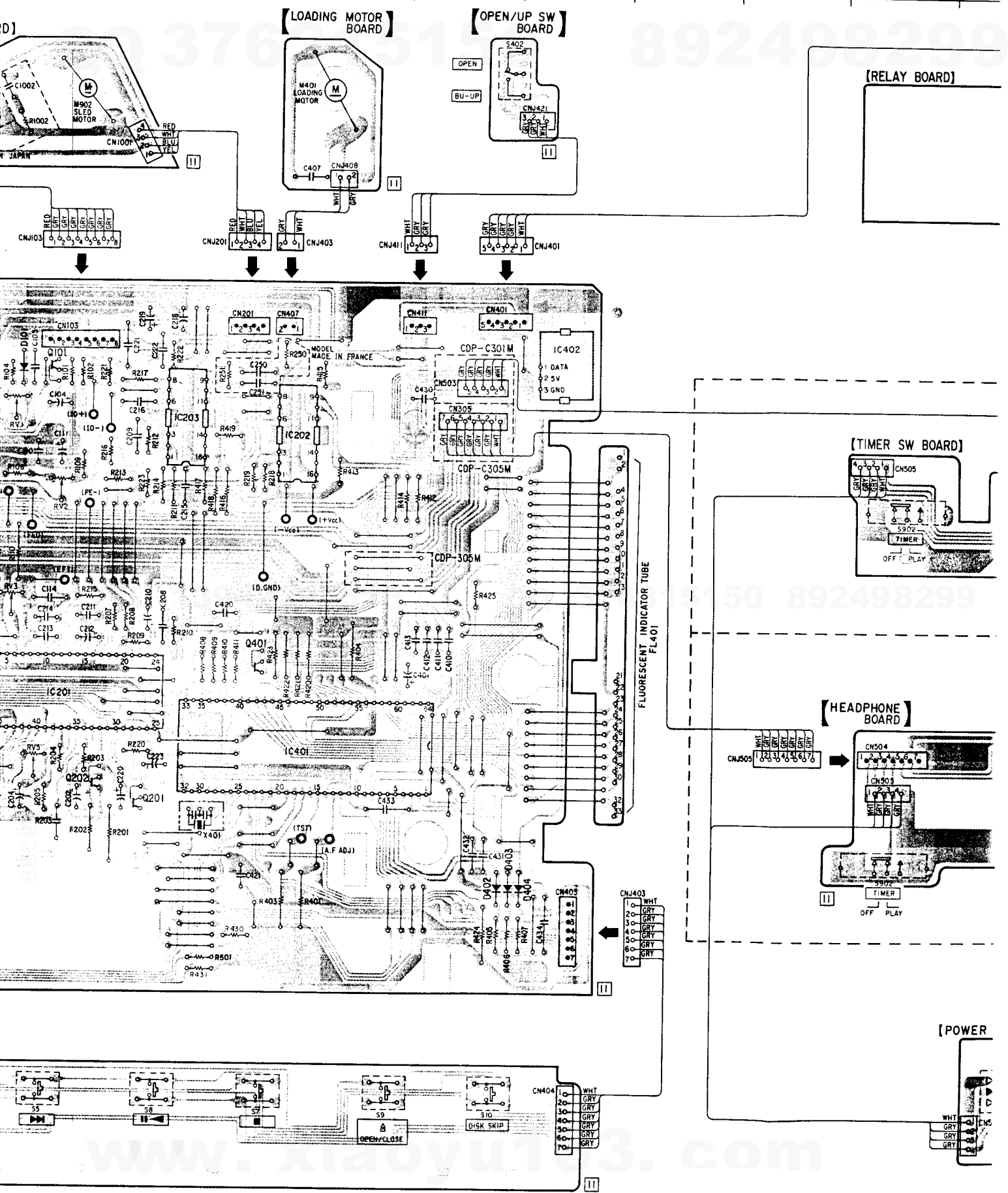

21	22	23	24	25	26
----	----	----	----	----	----

376315150 892498299

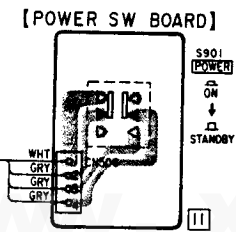
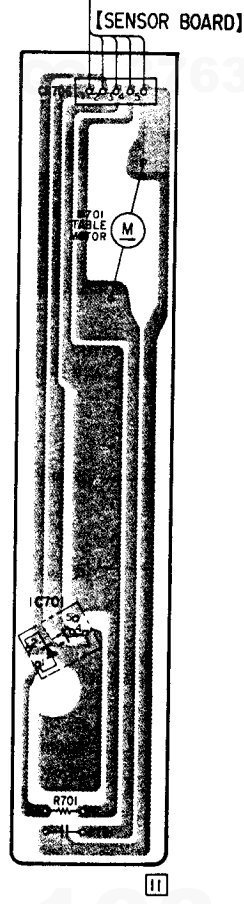
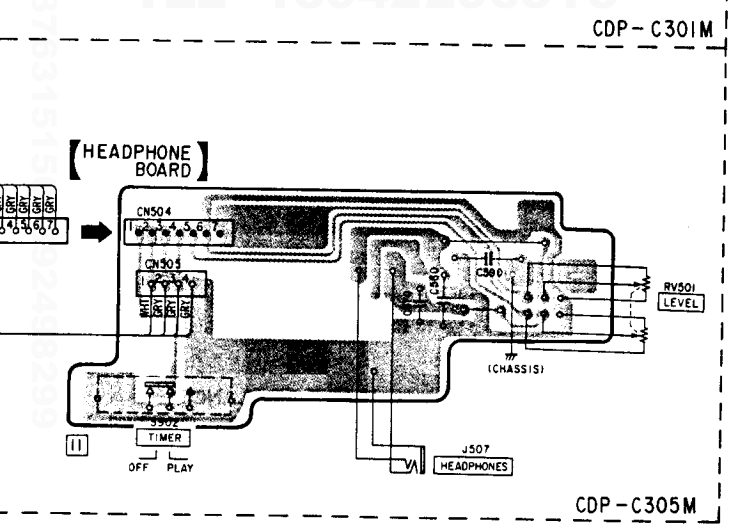
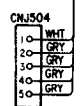
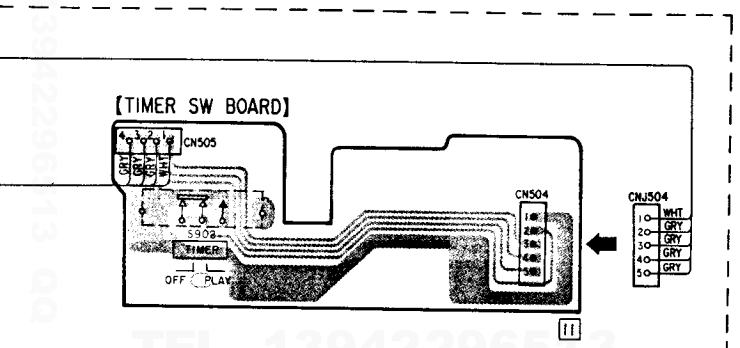
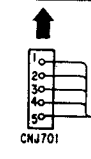
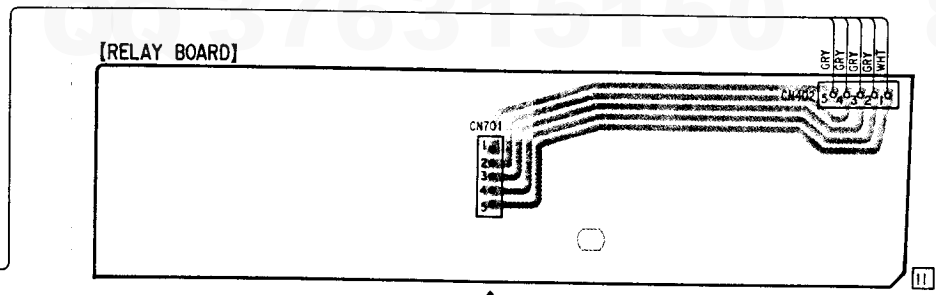

TEL 13942296513 00 376315150 892498299

TEL 13942296513 00 376315150 892498299

TEL 13942296513 376315150 892498299

www.xiaoyu163.com

1 2 3 4

A
B
C
D
E
F
G
H
I
J
K

QQ 376315150 892498299

• Semiconductor Lead Layouts

CXD1125Q

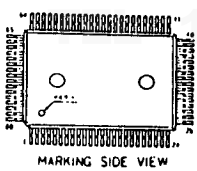

2SB1068K

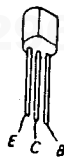

2SD774-34



LA6520

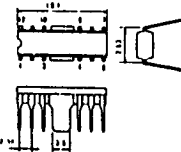

GP1A521

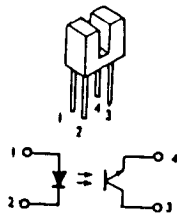

DTA124ES
DTA144ES
DTC114ES
DTC124ES
DTC143TS
DTC144ES



MPG06D-6052
RD4.7ES-B2
1SS202-1

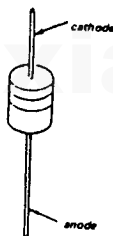

2SA1175-HFE



MAIN

LOADING MOTOR BOARD

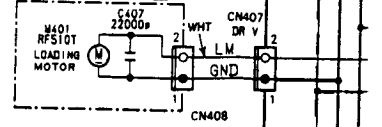

SL/SP MOTOR BOARD

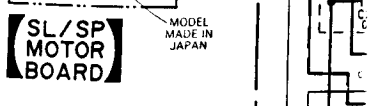

LOAD SLED FOCUS

TEL 13942296513 QQ 376315150 892498299

TEL 13942296513 QQ 376315150 892498299

TACT SW BOARD

QQ 376315150 892498299

[MAIN BOARD]

IC402
GPIU52A
REMOTE
SENSOR

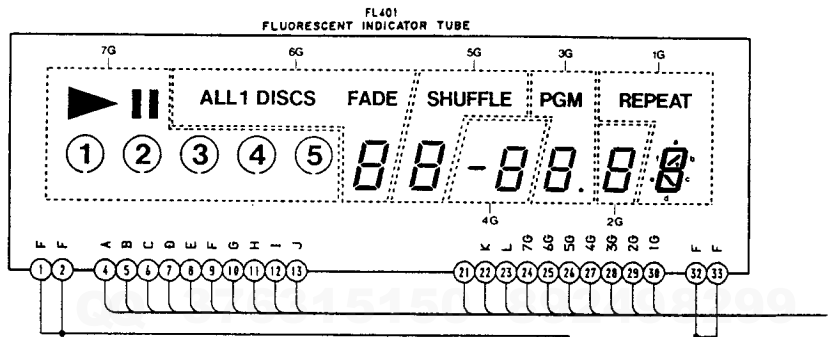

IC203
CXAI291P
LOADING MOTOR DRIVE/
SLED MOTOR DRIVE/
FOCUS COIL DRIVE

IC201
CXAI082BS
SLED SERVO

[LOADING MOTOR BOARD]

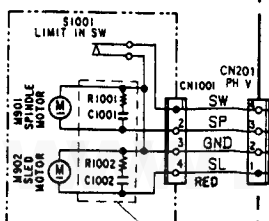
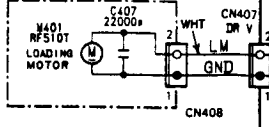

[SL/SP MOTOR BOARD]

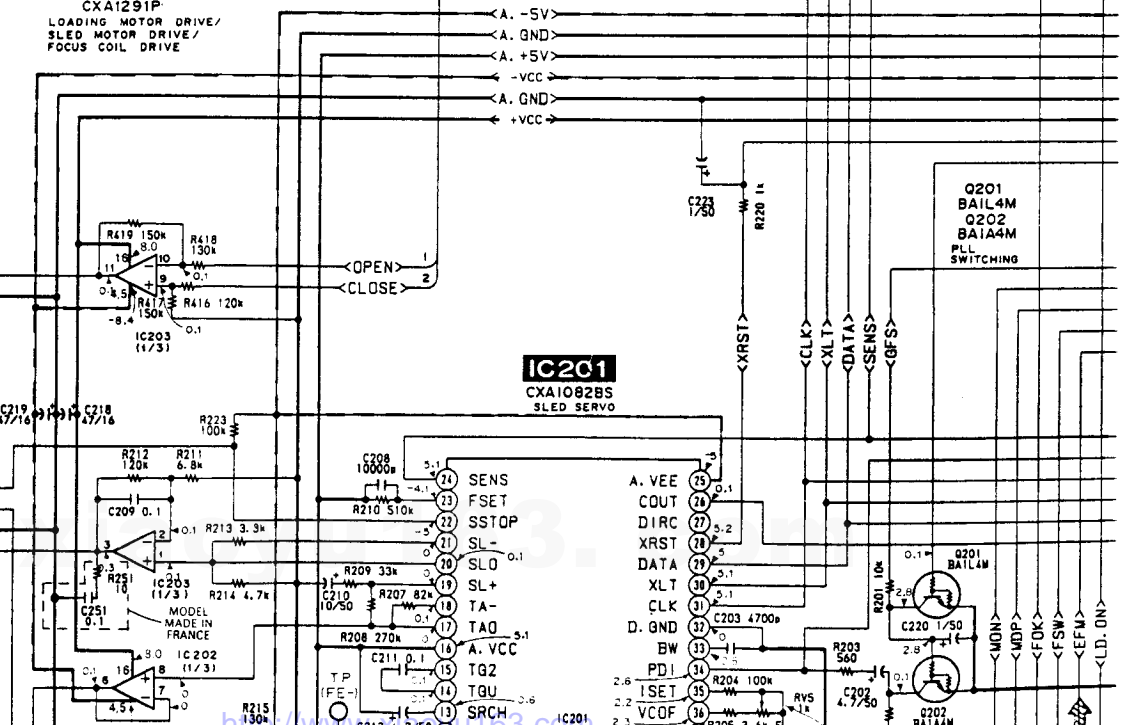

【CLOSE SW BOARD】 **【UP/OPEN SW BOARD】** **【DOWN SW BOARD】**

315150 892498299

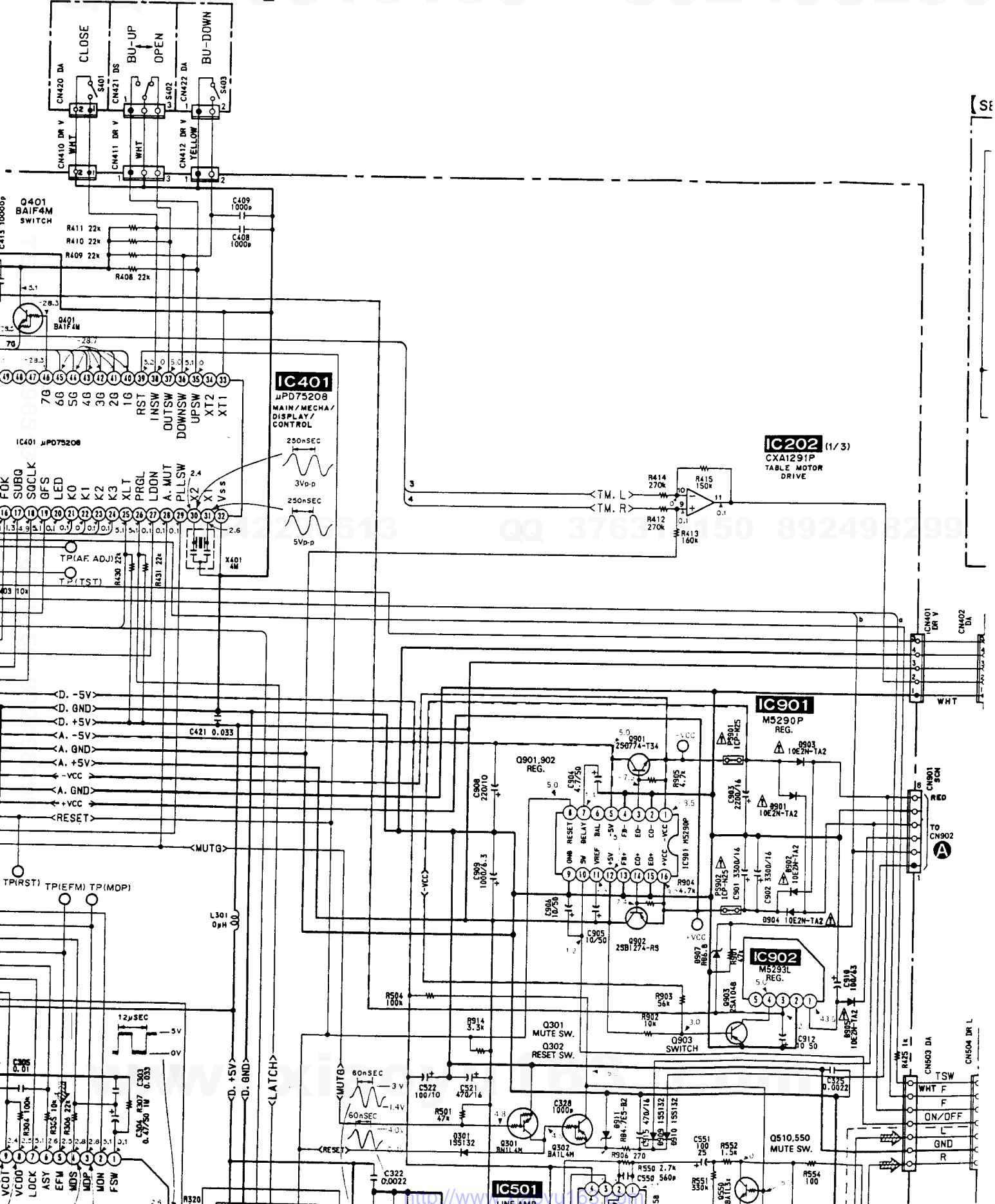

SE

TO CN302

TSW
WHT F
ON/OFF
GND
R

QQ 376315150 892498299

A

B

C

D

E

F

G

H

I

J

K

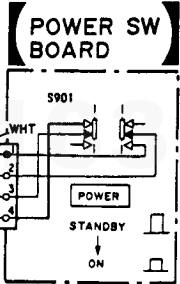
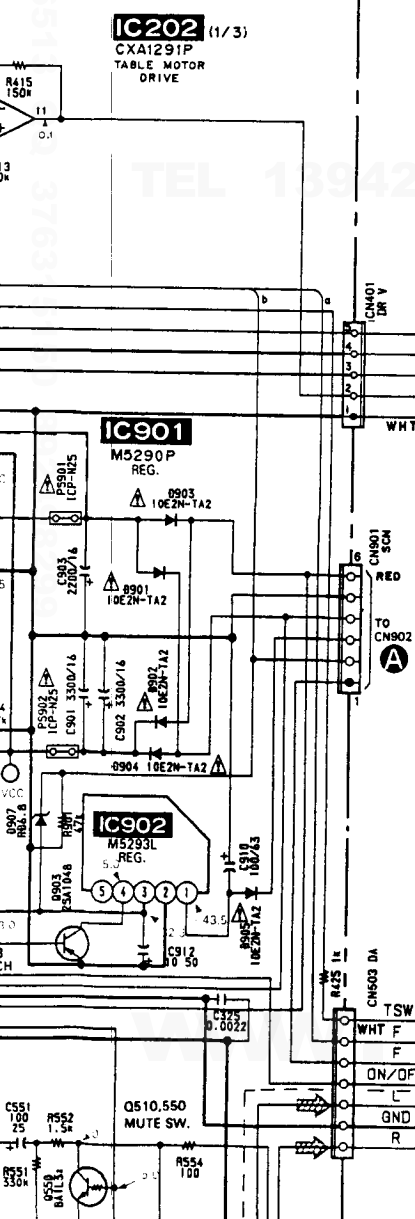
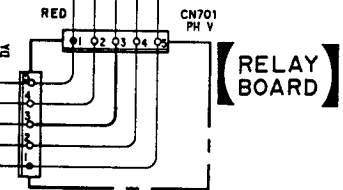
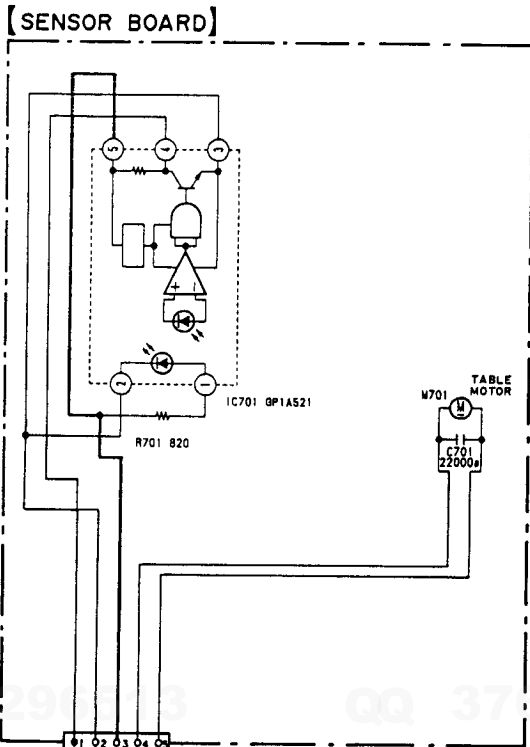

• Semiconductor Lead Layouts

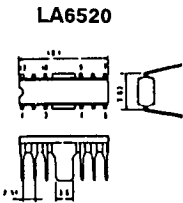
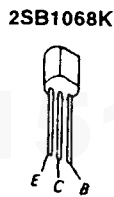
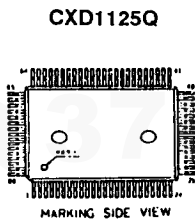

- DTA124ES
- DTA144ES
- DTC114ES
- DTC124ES
- DTC143TS
- DTC144ES

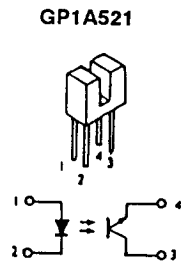

- MPG06D-6052
- RD4.7ES-B2
- 1SS202-1

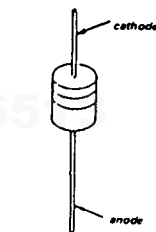

- 2SA1175-HFE



- 2SB1094-L

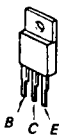

Note:

- All capacitors are in μF unless otherwise noted. pF: μpF 50 WV or less are not indicated except for electrolytics and tantalums.
- All resistors are in Ω and $\frac{1}{4}$ W or less unless otherwise specified.
- Δ : internal component.

Note: The components identified by mark Δ or dotted line with mark Δ are critical for safety. Replace only with part number specified.

- : B + Line.
- : B - Line.
- : adjustment for repair.
- Voltages and waveforms are dc with respect to ground under no-signal conditions.
- Voltages are taken with a VOM (10 M Ω /V). Voltage variations may be noted due to normal production tolerances.
- Waveforms are taken with an oscilloscope. Voltage variations may be noted due to normal production tolerances.
- Signal path.

F
G
H
I
J
K
L
M
N
O

892498299

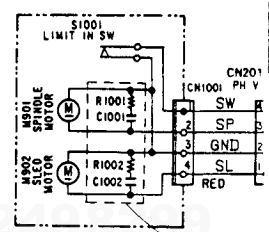
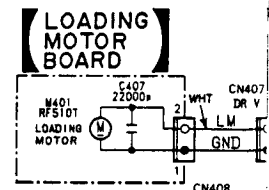

SL/SP MOTOR BOARD
MODEL MADE IN JAPAN

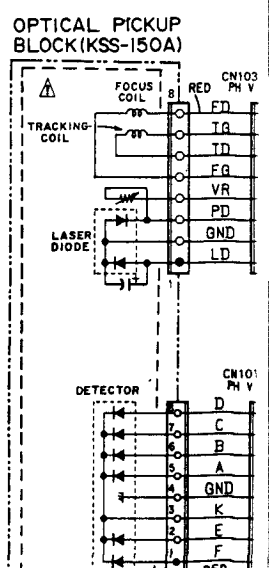

QQ 376315150 892498219

TEL 13942296513 00376315150 892498219

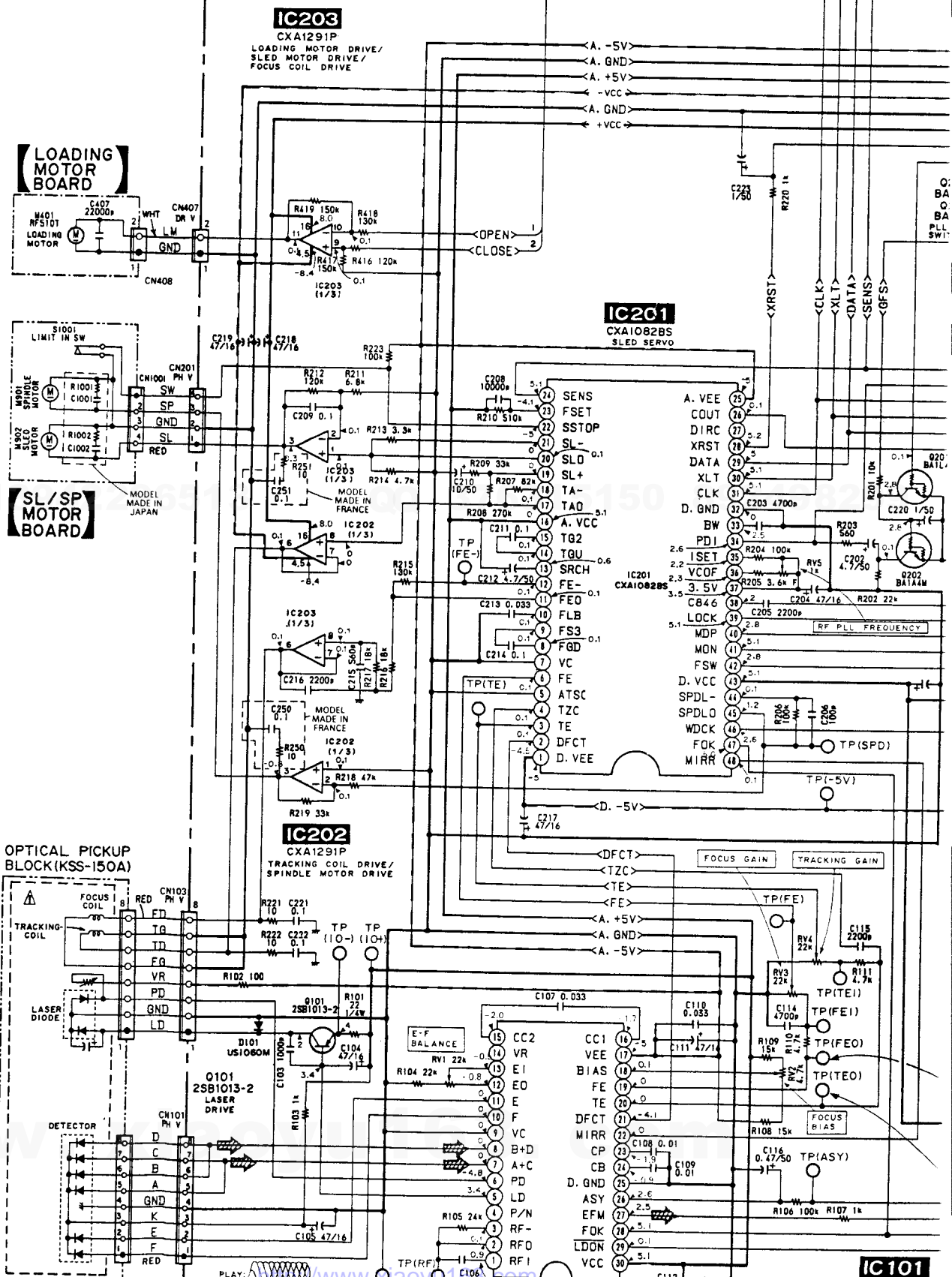

O. BA
C. BA
P.L.L.
SWI.

Q202
BATAAN

FOCUS GAIN

TRACKING GAIN

IC101

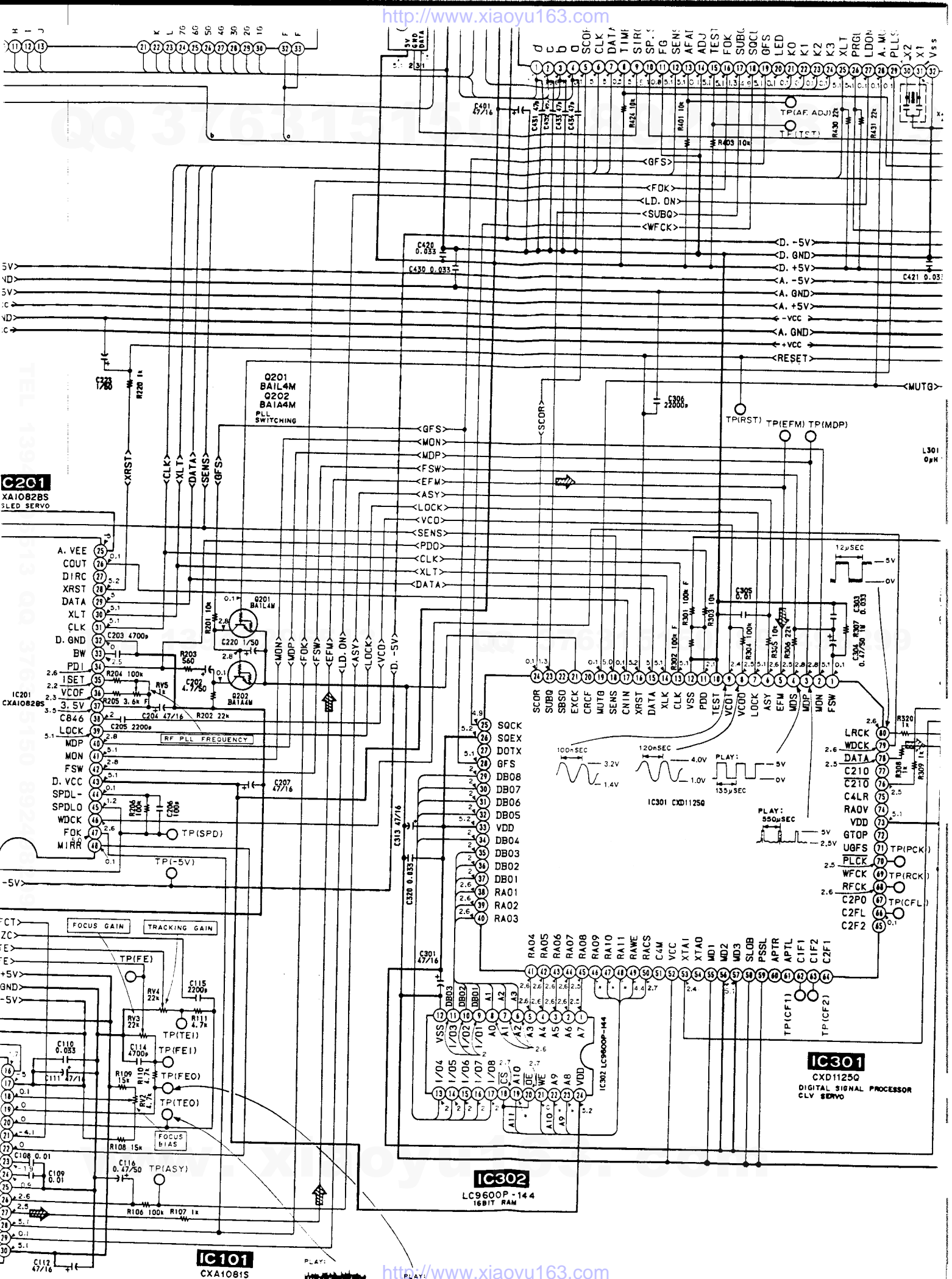

IC201
XA1082BS
SLED SERVO

Q201
BAIL4M
Q202
BA144M
PLL
SWITCHING

IC301
CXD11250
DIGITAL SIGNAL PROCESSOR
CLV SERVO

IC302
LC9600P-144
16BIT RAM

IC101
CX1081S

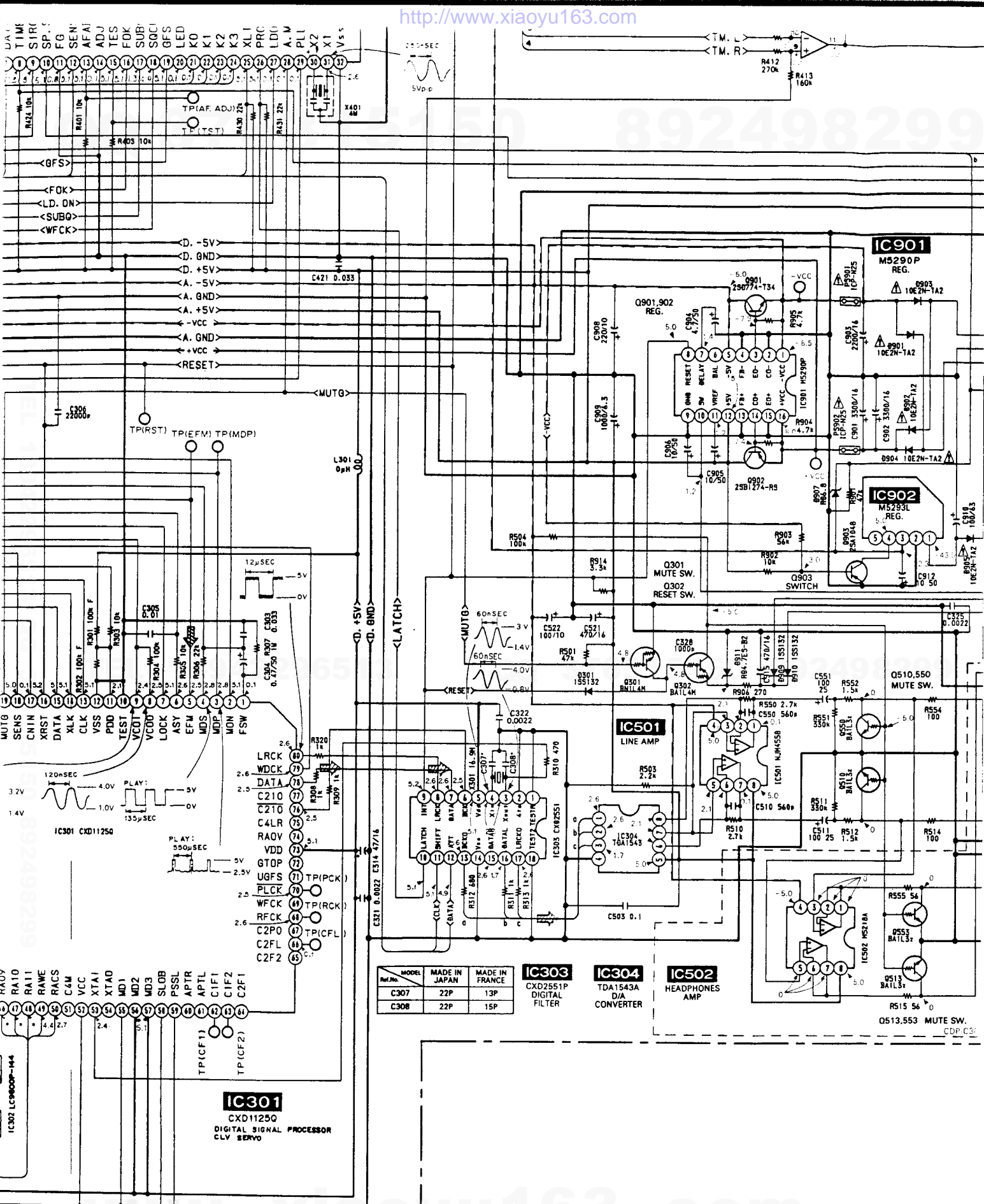

MODEL	MADE IN JAPAN	MADE IN FRANCE
C307	22P	13P
C308	22P	15P

IC303
CXD2551P
DIGITAL
FILTER

IC304
TDA1543A
D/A
CONVERTER

IC502
HEADPHONES
AMP

IC301
CXD1125Q
DIGITAL SIGNAL PROCESSOR
CLV SERVO

IC901
M5290P
REG.

IC902
M5293L
REG.

IC501
LINE AMP

Q510.550 MUTE SW.
COP.C3

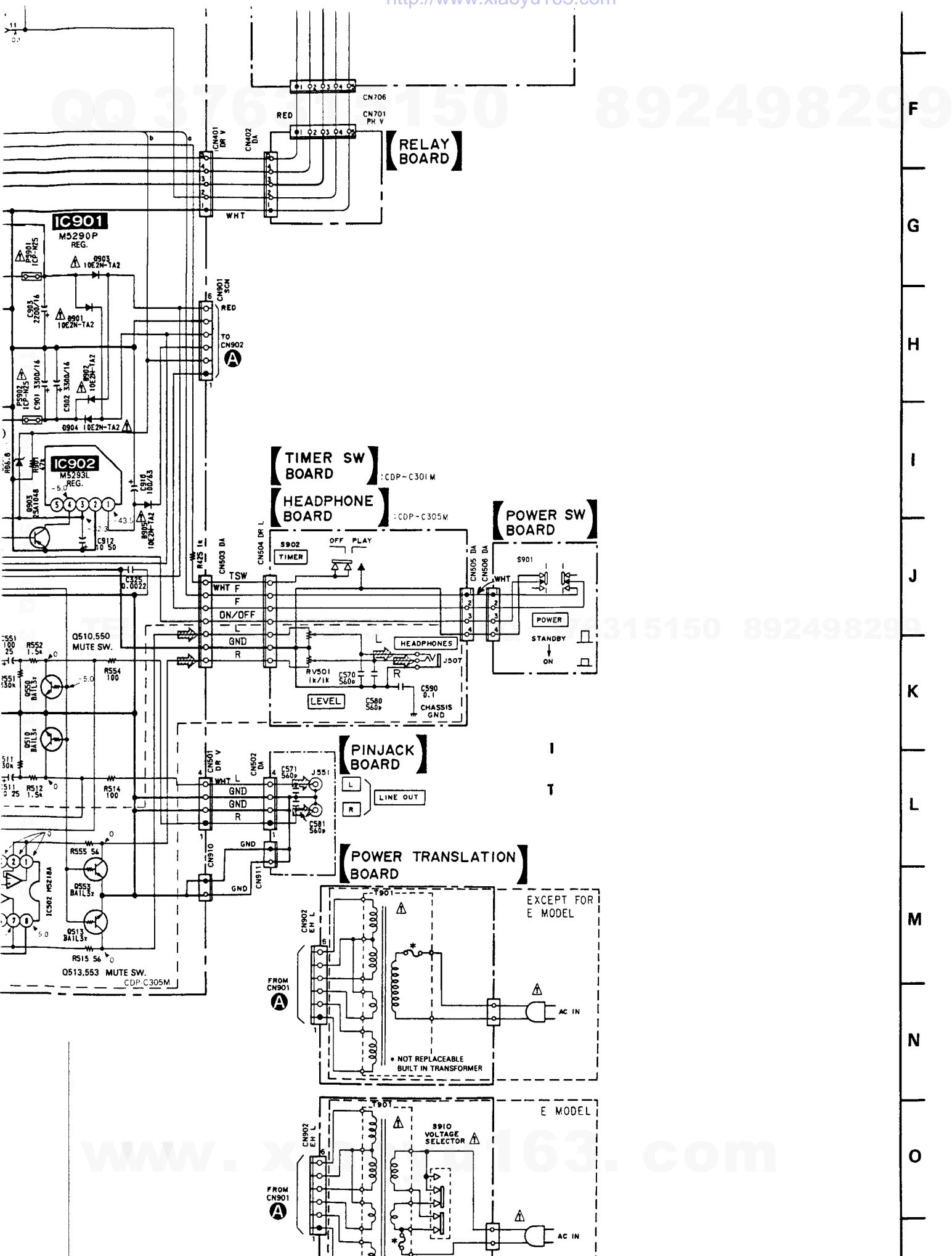

F

G

H

I

J

K

L

M

N

O

P

4394226543 00 376315150 892498299

QQ 376315150 892498299

IC101
CXA1081S

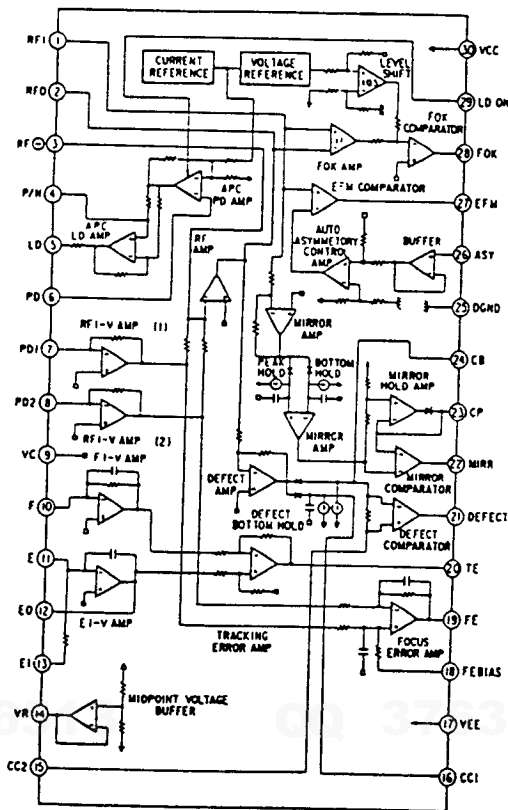

IC201
CXA1082BS

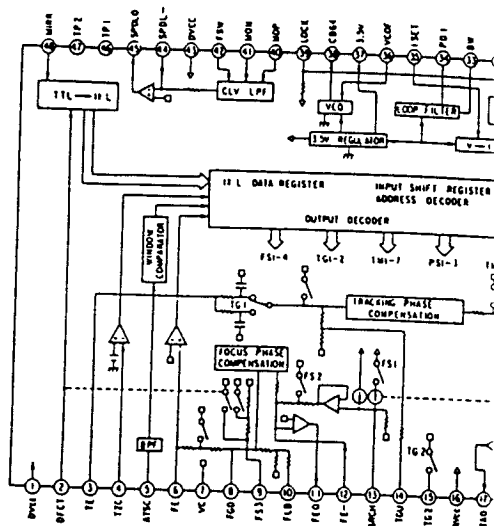

L
D.
DTR
DTC



2SA1175-HFE



TEL 43942296513 QQ 376315150 892498299

TEL 43942296513 QQ 376315150 892498299

QQ 376315150 892498299

IC201
CXA1082BS

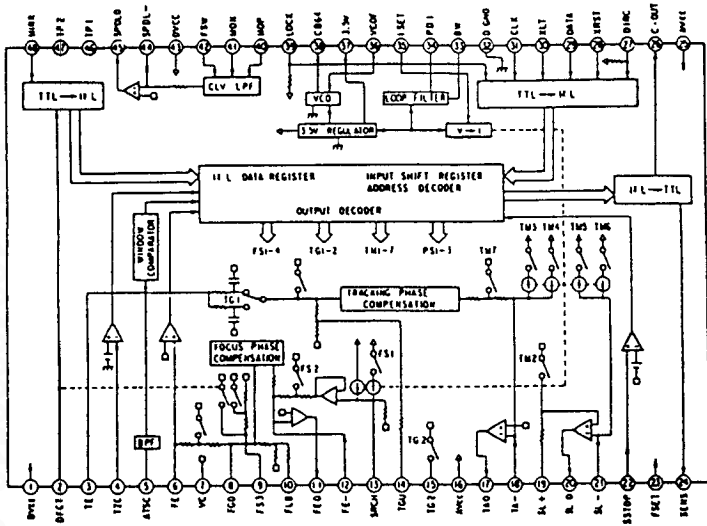

IC301
CXD1125Q

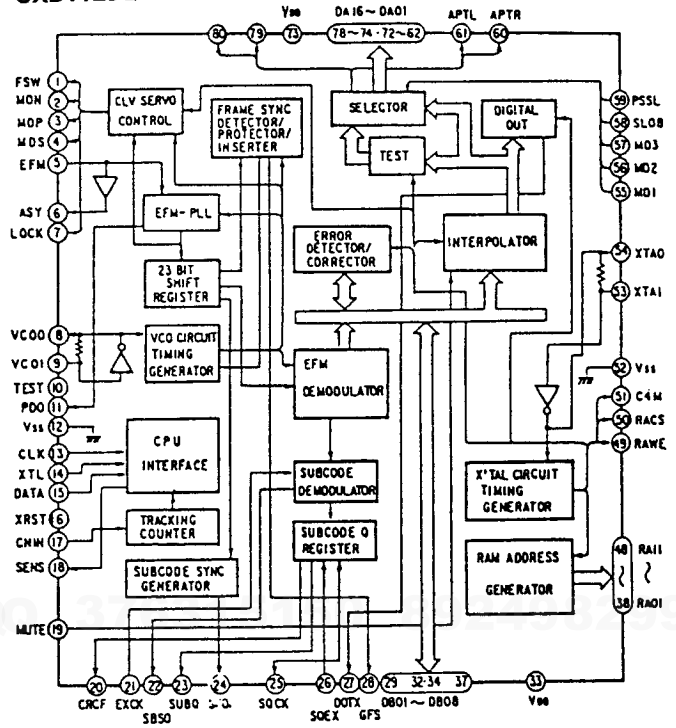

TEL 13942296513

QQ 376315150

892498299

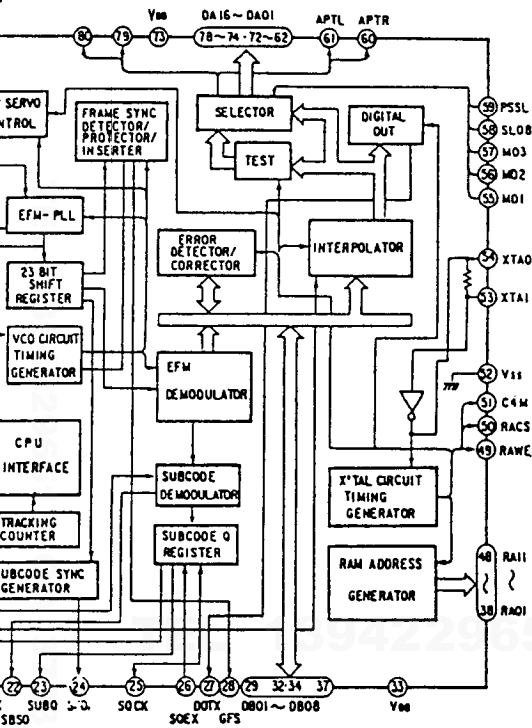

IC303 CXD2551P

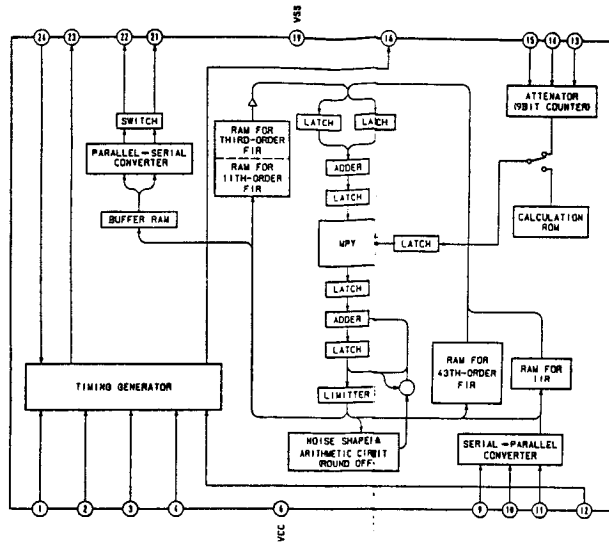

IC304 TDA1543A

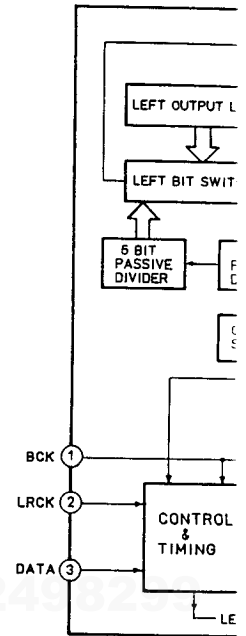

QQ 376315150

892498299

IC304
TDA1543A

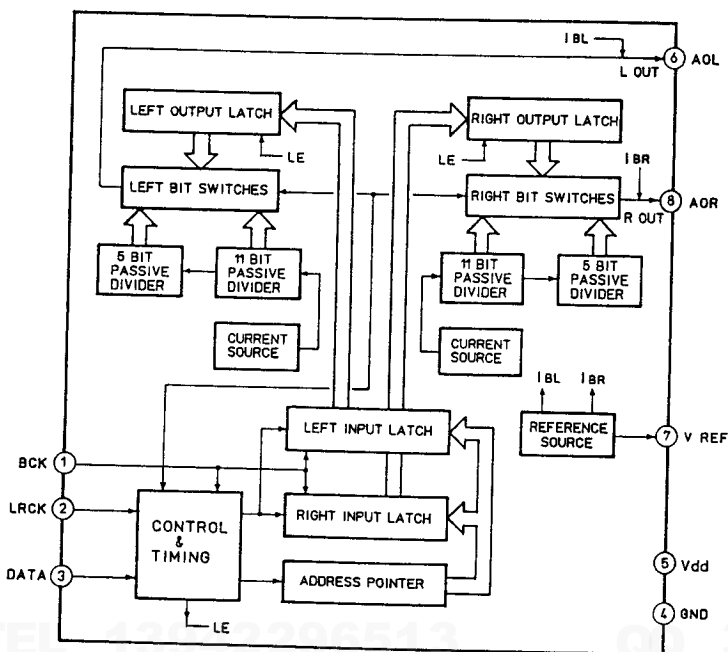

IC901
M529OP-16

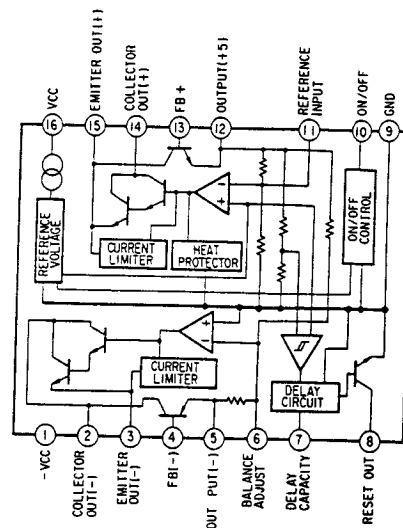

IC9
M5:

GND (

ON/OFF (

IN (

SECTION E

IC902
M5293L

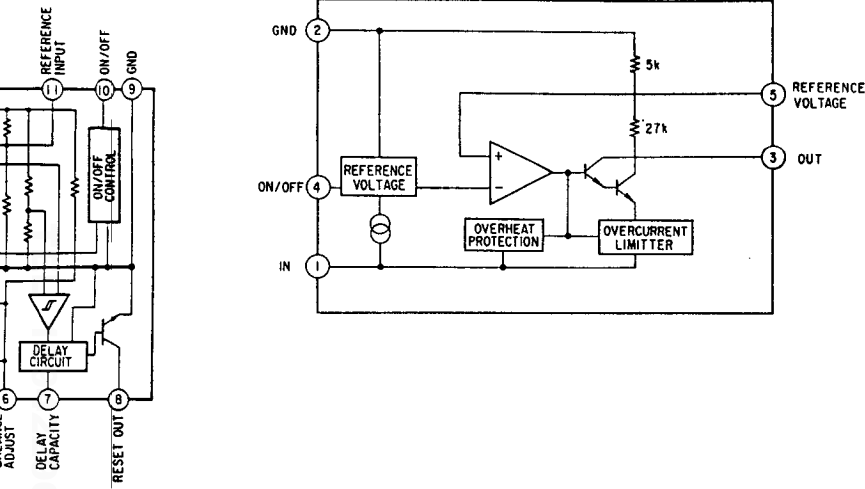

TEL 13942296513

QQ 376315150 892498299

www.xiaoyu163.com

TEL 13942296513 QQ 376315150 892498299

mechanical parts with no reference number in the exploded views are not supplied.

construction parts of an assembled part are indicated with a collation number in the remark column.

parts marked "*" are not stocked since they are seldom required for routine service. Some delay should be anticipated when ordering these items.

- Due to standardization, parts with part number suffix -XX and -X may be different from the parts specified in the components used on the set.
- Color Indication of Appearance Parts Example:
(RED) ... KNOB, BALANCE (WHITE)
↑ Cabinet's Color ↑ Parts Color

The components identified by mark Δ or dotted line with mark Δ are critical for safety. Replace only with part number specified.

FRONT PANEL AND CASE ASSEMBLY SECTION

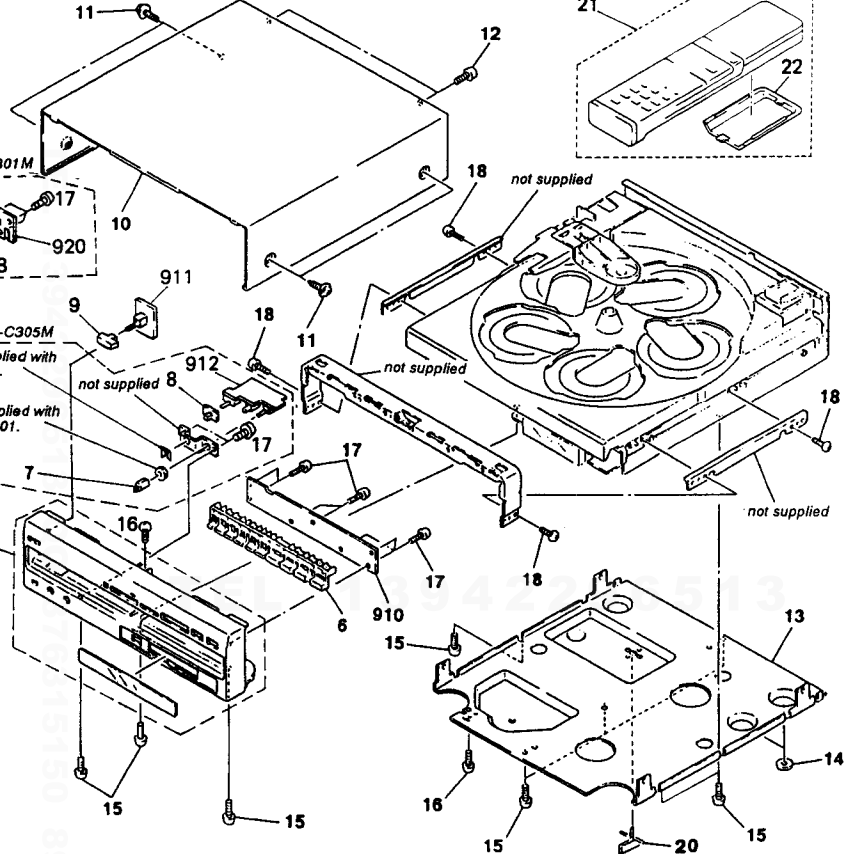

No.	Description	Remarks	No.	Part No.	Description	Remarks
17	(C301M:AEP,UK:GRAY)...PANEL ASSY, FRONT		17	4-928-635-01	SCREW, +BV (2.6X8) TAPPING	
18	(C305M:BLACK)...PANEL ASSY, FRONT		18	7-685-648-79	SCREW +BTP 3X12 TYPE2 N-S	
19	(C305M:GRAY)...PANEL ASSY, FRONT		20	*4-924-418-01	PLATE (TRANSPORT), LOCK	
20	(C301M:US)...PANEL ASSY, FRONT		21	1-465-398-11	(M305M)...COMMANDER, REMOTE (RM-0306)	
21			22	2-181-754-01	(C305M)...COVER, BATTERY	
910			910	*1-634-981-11	(MADE IN FRANCE)...PC BOARD, TACT SW	
911			911	*1-635-062-11	(MADE IN JAPAN)...PC BOARD, TACT SW	
912			911	*1-634-988-11	(MADE IN FRANCE)...PC BOARD, POWER SW	
913			911	*1-635-069-11	(MADE IN JAPAN)...PC BOARD, POWER SW	
914			912	*1-634-989-11	(C305M:MADE IN FRANCE)...PC BOARD, HEADPHONE	
915			912	*1-635-070-11	(C305M:MADE IN JAPAN)...PC BOARD, HEADPHONE	
916			920	*1-634-979-11	(C301M:MADE IN FRANCE)...PC BOARD, TIMER SWITCH	
917			920	*1-635-060-11	(C301M:MADE IN JAPAN)...PC BOARD, TIMER SWITCH	

(2) DISC TABLE ASSEMBLY SECTION

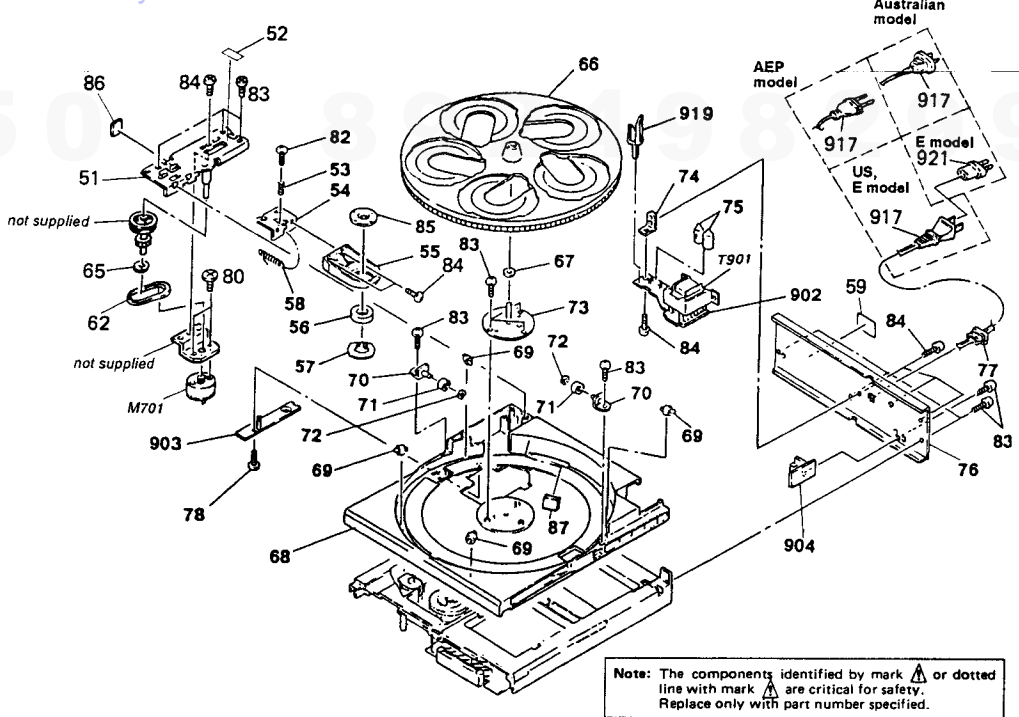

No.	Part No.	Description	Remarks	No.	Part No.	Description	Remarks
51	*X-4924-472-1	BRACKET (R GEAR) ASSY		78	7-685-134-19	SCREW +BTP 2.6X8 TYPE2 N-S	
52	3-831-441-XX	SPACER		80	7-621-775-08	SCREW +P 2.6X3	
53	4-924-477-01	SPRING, COMPRESSION		82	7-682-548-09	SCREW +B 3X8	
54	*4-926-328-01	BRACKET (ADJUSTMENT A)		83	7-685-647-79	SCREW +BVTP 3X10 TYPE2 N-S	
55	*4-926-326-01	BRACKET (PRESS PULLEY)		84	7-682-547-09	SCREW +BVTT 3X6 (S)	
56	1-452-340-21	MAGNET	22	85	4-921-029-01	YOKE, CHUCKING	
57	4-921-022-01	PULLEY, CHUCKING		86	9-911-841-XX	CUSHION	
58	4-924-421-01	SPRING (C), TENSION		87	4-930-573-01	CUSHION	
59	*4-885-838-00	(EXCEPT US:MADE IN JAPAN)...LABEL, CLASS		902	*1-634-978-11	(MADE IN FRANCE)...PC BOARD, P.T.	
60	*4-914-253-01	(EXCEPT US:MADE IN FRANCE)...LABEL, CLASS		902	*1-635-059-11	(MADE IN JAPAN)...PC BOARD, P.T.	
62	3-664-304-11	BELT, MOTOR		903	*1-634-982-11	(MADE IN FRANCE)...PC BOARD, SENSOR	
65	4-937-969-01	WASHER, STOPPER		903	*1-635-063-11	(MADE IN JAPAN)...PC BOARD, SENSOR	
66	4-930-531-01	TABLE (C), DISK		904	*1-634-980-11	(MADE IN FRANCE)...PC BOARD, PIN JACK	
67	4-926-307-01	WASHER		904	*1-635-061-11	(MADE IN JAPAN)...PC BOARD, PIN JACK	
68	4-924-406-62	(BLACK)...TABLE (A), DISK		917	Δ 1-551-188-XX	(E)...CORD, POWER	
69	4-924-406-72	(GRAY)...TABLE (A), DISK		917	Δ 1-551-478-00	(US)...CORD, POWER	
70	*X-4924-409-1	SHAFT (ROLLER B) ASSY		917	Δ 1-555-795-00	(AEP:MADE IN JAPAN)...CORD, POWER	
71	*X-4924-410-1	BRACKET (ROLLER) ASSY		917	Δ 1-574-127-11	(AEP:MADE IN FRANCE)...CORD, POWER	
72	*X-4924-408-3	COLLAR (ROLLER) ASSY		917	Δ 1-574-390-11	(UK:MADE IN FRANCE)...CORD, POWER	
73	3-325-290-21	WASHER, STOPPER		917	Δ 1-574-904-11	(Australian)...CORD, POWER	
74	*X-4924-402-1	BRACKET (A) ASSY		919	1-535-416-00	TERMINAL	
75	*4-923-506-01	BRACKET (PC BOARD)		921	Δ 1-569-U07-11	(E)...ADAPTOR, CONVERSION 2P	
76	*4-912-962-01	COVER (1P), TERMINAL		M701	A-4604-585-A	(MADE IN JAPAN)...MOTOR ASSY, ROTARY	
77	*4-934-354-11	(C305M:AEP:MADE IN JAPAN)...PANEL, BACK		M701	X-4604-572-A	(MADE IN FRANCE)...MOTOR ASSY, ROTARY	
78	*4-934-354-31	(C305M:Australian)...PANEL, BACK		T901	Δ 1-449-957-11	(AEP,UK:MADE IN FRANCE)...TRANSFORMER, POWER	
79	*4-934-354-41	(AEP,UK:MADE IN FRANCE)...PANEL, BACK		T901	Δ 1-449-959-11	(E)...TRANSFORMER, POWER	
80	*4-934-354-51	(C305M:E)...PANEL, BACK		T901	Δ 1-449-960-11	(AEP,UK,Australian:MADE IN JAPAN)...TRANSFORMER, POWER	
81	*4-934-354-61	(C301M:AEP:MADE IN JAPAN)...PANEL, BACK		T901	Δ 1-450-136-11	(US)...TRANSFORMER, POWER	
82	*4-934-354-71	(EXCEPT US)...PANEL, BACK					

Note: The components identified by mark Δ or dotted line with mark Δ are critical for safety. Replace only with part number specified.

(4) BASE UNIT SECTION
 BU-5C: MODEL MADE IN JAPAN
 BU-5M: MODEL MADE IN FRANCE

Note: The components identified by mark Δ or dotted line with mark Δ are critical for safety. Replace only with part number specified.

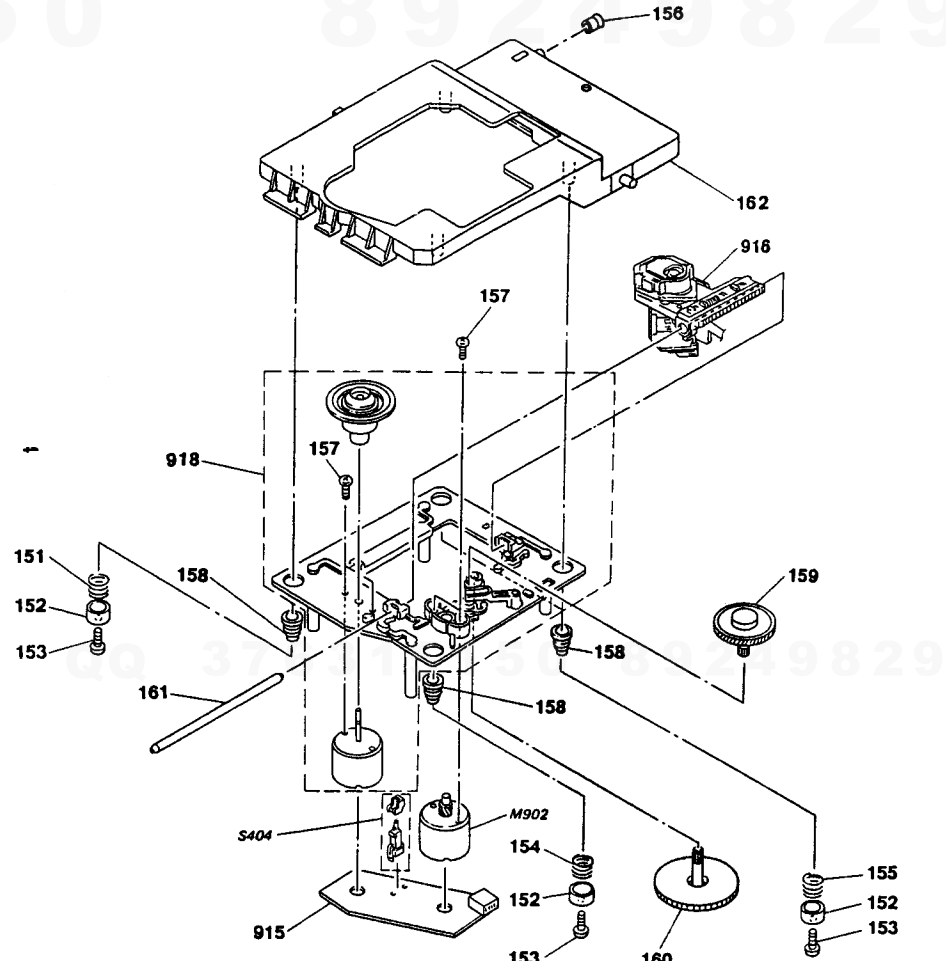
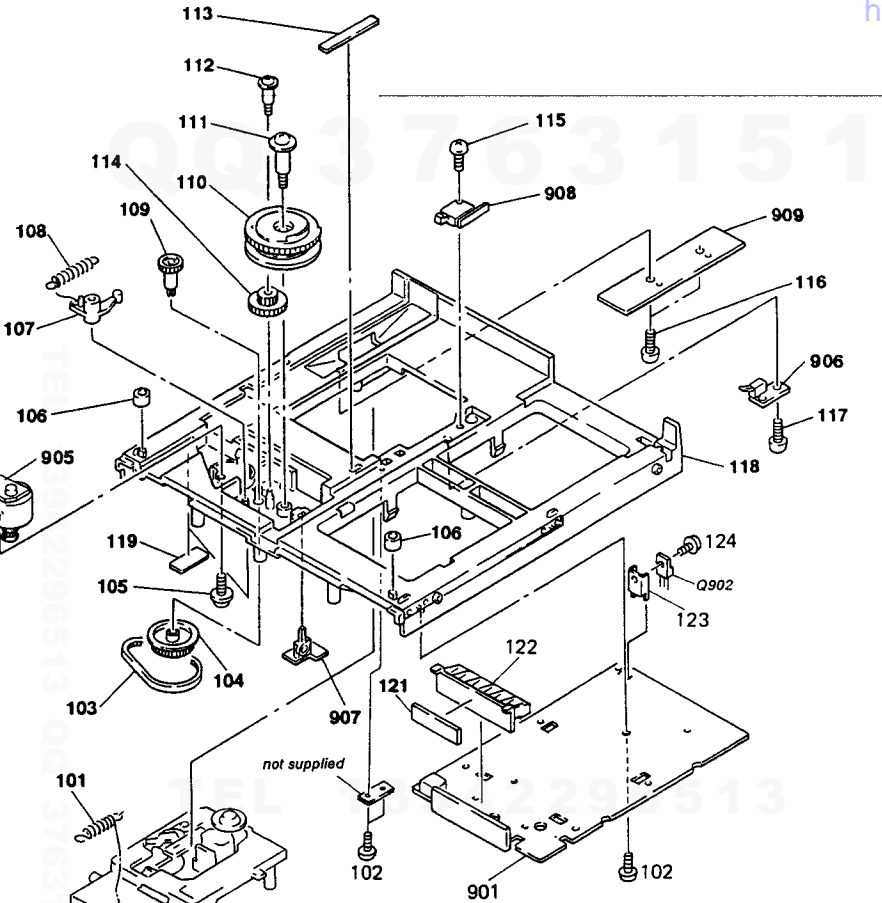

No.	Description	Remarks	No.	Part No.	Description	Remarks
924-411-01	SPRING (A), TENSION		901	*A-4617-417-A	(C305M:MADE IN FRANCE)...MOUNTED PCB, MAIN	
585-647-79	SCREW +BVTP 3X10 TYPE2 N-S			*A-4617-431-A	(C305M:MADE IN JAPAN)...MOUNTED PCB, MAIN	
930-528-01	BELT (TIMING)			*A-4617-489-A	(C301M:MADE IN FRANCE)...MOUNTED PCB, MAIN	
924-443-1	PULLEY ASSY			*A-4617-490-A	(C301M:MADE IN JAPAN)...MOUNTED PCB, MAIN	
521-759-45	+PSW, 2.6X6		905	*1-634-983-11	(MADE IN FRANCE)...PC BOARD, L.M.	
676-990-01	CUSHION			*1-635-064-11	(MADE IN JAPAN)...PC BOARD, L.M.	
1717-519-01	LEVER, SET		906	*1-634-984-11	(MADE IN FRANCE)...PC BOARD, DOWN SW	
924-412-01	SPRING (B), TENSION			*1-635-065-11	(MADE IN JAPAN)...PC BOARD, DOWN SW	
924-425-01	GEAR (LOADING B)		907	*1-634-985-11	(MADE IN FRANCE)...PC BOARD, OPEN/UP SW	
924-431-01	GEAR (LOADING A)			*1-635-066-11	(MADE IN JAPAN)...PC BOARD, OPEN/UP SW	
926-317-01	SCREW, STEP		908	*1-634-986-11	(MADE IN FRANCE)...PC BOARD, CLOSE SW	
926-320-01	SCREW (B), STEP			*1-635-067-11	(MADE IN JAPAN)...PC BOARD, CLOSE SW	
926-316-01	SHEET		909	*1-634-987-11	(MADE IN FRANCE)...PC BOARD, TRANSLATION	
924-426-01	GEAR (LOADING C)			*1-635-068-11	(MADE IN JAPAN)...PC BOARD, TRANSLATION	
924-426-01	SCREW +BTP 2.6X14 TYPE2 N-S		M401	A-4608-350-A	(MADE IN JAPAN)...MOTOR ASSY, LOADING	
685-137-19	SCREW +BTP 2.6X14 TYPE2 N-S		M401	X-4604-554-A	(MADE IN FRANCE)...MOTOR ASSY, LOADING	
585-646-79	SCREW +BVTP 3X8 TYPE2 N-S		Q901	8-729-140-96	TRANSISTOR 2SD774-34	
585-134-19	SCREW +P 2.6X8 TYPE2 NON-SLIT					
924-407-06	FRAME					
831-441-XX	CUSHION (B), CABINET					
926-354-01	SHEET (ADHESIVE)					
926-324-01	BRACKET (FL)					
875-327-01	HEAT SINK					
682-547-04	SCREW +BVTT 3X6 (S)					

No.	Part No.	Description	Remarks	No.	Part No.	Description	Remarks
151	4-917-541-01	SPRING (B) (SILVER)		161	4-917-565-01	SHAFT, SLED	
152	4-917-508-01	HOLDER, SP		162	4-924-445-01	BRACKET (BU)	
153	7-685-135-19	SCREW +P 2.6X10 TYPE2 NON-SLIT		915	*1-632-170-11	(MADE IN JAPAN)...PC BOARD, SL/SP MOTOR	
154	4-918-669-01	SPRING (W) (BLACK)			*1-632-460-12	(MADE IN FRANCE)...PC BOARD, SL/SP MOTOR	
155	4-917-507-01	SPRING (H) (GOLD)		916	Δ 8-848-127-11	DEVICE, OPTICAL KSS-210A	
156	4-917-515-01	ROLLER		918	X-4917-523-1	BASE ASSY (SPINDLE MOTOR)	
157	7-621-255-15	SCREW +P 2X3		M902	X-4917-504-1	MOTOR ASSY (SLED)	
158	4-917-562-01	INSULATOR		159	4-917-567-01	GEAR (M)	
159	4-917-567-01	GEAR (M)		160	4-917-564-01	GEAR (P), FLATNESS	
160	4-917-564-01	GEAR (P), FLATNESS		S404	1-570-822-11	SWITCH, LEAF (LIMIT IN)	

SECTION 6 ELECTRICAL PARTS LIST

NOTE:

- Due to standardization, replacements in the parts list may be different from the parts specified in the diagrams or the components used on the set.
- Items marked "*" are not stocked since they are seldom required for routine service. Some delay should be anticipated when ordering these items.
- If there are two or more same circuits in a set such as a stereophonic machine, only typical circuit parts may be indicated and capacitors and resistors in other same circuits may be omitted.

CAPACITORS:
MF: μ F, PF: μ MF.

RESISTORS
• All resistors are in ohms.
• F: nonflammable

COILS
• MMH: mH, UH: μ H

SEMICONDUCTORS
In each case, U: μ , for example:
UA....: μ A...., UPA....: μ PA....,
UPC....: μ PC, UPD....: μ PD....

The components identified by mark Δ or dotted line with mark Δ are critical for safety. Replace only with part number specified.

Ref.No.	Part No.	Description
901	*A-4617-417-A	(C305M:MADE IN FRANCE) ...MOUNTED PCB, MAIN
	*A-4617-431-A	(C305M:MADE IN JAPAN) ...MOUNTED PCB, MAIN
	*A-4617-489-A	(C301M:MADE IN FRANCE) ...MOUNTED PCB, MAIN
	*A-4617-490-A	(C301M:MADE IN JAPAN) ...MOUNTED PCB, MAIN
902	*1-634-978-11	(MADE IN FRANCE)...PC BOARD, P.T.
	*1-635-059-11	(MADE IN JAPAN)...PC BOARD, P.T.
903	*1-634-982-11	(MADE IN FRANCE)...PC BOARD, SENSOR
	*1-635-063-11	(MADE IN JAPAN)...PC BOARD, SENSOR
904	*1-634-980-11	(MADE IN FRANCE)...PC BOARD, PIN JACK
	*1-635-061-11	(MADE IN JAPAN)...PC BOARD, PIN JACK
905	*1-634-983-11	(MADE IN FRANCE)...PC BOARD, L.M.
	*1-635-064-11	(MADE IN JAPAN)...PC BOARD, L.M.
906	*1-634-984-11	(MADE IN FRANCE)...PC BOARD, DOWN SW
	*1-635-065-11	(MADE IN JAPAN)...PC BOARD, DOWN SW
907	*1-634-985-11	(MADE IN FRANCE)...PC BOARD, OPEN/UP SW
	*1-635-066-11	(MADE IN JAPAN)...PC BOARD, OPEN/UP SW
908	*1-634-986-11	(MADE IN FRANCE)...PC BOARD, CLOSE SW
	*1-635-067-11	(MADE IN JAPAN)...PC BOARD, CLOSE SW
909	*1-634-987-11	(MADE IN FRANCE)...PC BOARD, TRANSLATION
	*1-635-068-11	(MADE IN JAPAN)...PC BOARD, TRANSLATION
910	*1-634-981-11	(MADE IN FRANCE)...PC BOARD, TACT SW
	*1-635-062-11	(MADE IN JAPAN)...PC BOARD, TACT SW
911	*1-634-988-11	(MADE IN FRANCE)...PC BOARD, POWER SW
	*1-635-069-11	(MADE IN JAPAN)...PC BOARD, POWER SW
912	*1-634-989-11	(C305M:MADE IN FRANCE) ...PC BOARD, HEADPHONE
	*1-635-070-11	(C305M:MADE IN JAPAN) ...PC BOARD, HEADPHONE
915	*1-632-170-11	(MADE IN JAPAN)...PC BOARD, SL/SP MOTOR
	*1-632-460-12	(MADE IN FRANCE)...PC BOARD, SL/SP MOTOR
916	Δ 8-848-127-11	DEVICE, OPTICAL KSS-210A
917	Δ 1-551-188-XX	(E).....CORD, POWER
	Δ 1-551-478-00	(US).....CORD, POWER
	Δ 1-555-795-00	(AEP:MADE IN JAPAN)CORD, POWER, EULO PLUG
	Δ 1-574-127-11	(AEP:MADE IN FRANCE)...CORD, POWER
	Δ 1-574-390-11	(UK:MADE IN FRANCE)...CORD, POWER
	Δ 1-574-904-11	(Australian).....CORD, POWER
918	X-4917-523-1	BASE ASSY (SPINDLE MOTOR)
919	1-535-416-00	TERMINAL

Ref.No.	Part No.	Description			
920	*1-634-979-11	(C301M:MADE IN FRANCE) ...PC BOARD, TIMER SWITCH			
	*1-635-060-11	(C301M:MADE IN JAPAN) ...PC BOARD, TIMER SWITCH			
921	Δ 1-569-007-11	(E)...ADAPTOR, CONVERSION 2P			
C103	1-162-294-31	CERAMIC	0.001MF	10%	50V
C104	1-124-477-11	ELECT	47MF	20%	16V
C105	1-124-477-11	ELECT	47MF	20%	16V
C106	1-161-375-00	CERAMIC	0.0022MF	30%	16V
C107	1-136-159-00	FILM	0.033MF	5%	50V
C108	1-136-153-00	FILM	0.01MF	5%	50V
C109	1-136-153-00	FILM	0.01MF	5%	50V
C110	1-136-159-00	FILM	0.033MF	5%	50V
C111	1-124-477-11	ELECT	47MF	20%	16V
C112	1-124-477-11	ELECT	47MF	20%	16V
C114	1-161-377-00	CERAMIC	0.0047MF	20%	16V
C115	1-161-375-00	CERAMIC	0.0022MF	30%	16V
C116	1-124-902-00	ELECT	0.47MF	20%	50V
C202	1-124-927-11	ELECT	4.7MF	20%	50V
C203	1-161-377-00	CERAMIC	0.0047MF	20%	16V
C204	1-124-477-11	ELECT	47MF	20%	16V
C205	1-161-375-00	CERAMIC	0.0022MF	30%	16V
C206	1-162-282-31	CERAMIC	100PF	10%	50V
C207	1-124-477-11	ELECT	47MF	20%	16V
C208	1-162-306-11	CERAMIC	0.01MF	20%	16V
C209	1-164-159-11	CERAMIC	0.1MF		50V
C210	1-123-875-11	ELECT	10MF	20%	50V
C211	1-136-165-00	FILM	0.1MF	5%	50V
C212	1-124-927-11	ELECT	4.7MF	20%	50V
C213	1-136-159-00	FILM	0.033MF	5%	50V
C214	1-136-165-00	FILM	0.1MF	5%	50V
C215	1-162-291-31	CERAMIC	560PF	10%	50V
C216	1-161-375-00	CERAMIC	0.0022MF	30%	16V
C217	1-124-477-11	ELECT	47MF	20%	16V
C218	1-124-477-11	ELECT	47MF	20%	16V
C219	1-124-477-11	ELECT	47MF	20%	16V
C220	1-124-791-11	ELECT	1MF	20%	50V
C221	1-164-159-11	CERAMIC	0.1MF		50V
C222	1-164-159-11	CERAMIC	0.1MF		50V
C223	1-124-791-11	ELECT	1MF	20%	50V
C250	1-164-159-11	(MADE IN FRANCE) ...CERAMIC	0.1MF		50V
C251	1-164-159-11	(MADE IN FRANCE) ...CERAMIC	0.1MF		50V
C301	1-124-477-11	ELECT	47MF	20%	16V

0376315150 892498299

Ref.No.	Part No.	Description			
C303	1-136-159-00	FILM	0.033MF	5%	50V
C304	1-124-902-00	ELECT	0.47MF	20%	50V
C305	1-136-153-00	FILM	0.01MF	5%	50V
C306	1-161-494-00	CERAMIC	0.022MF		25V
C307	1-162-202-31	(MADE IN FRANCE) ...CERAMIC	13PF	5%	50V
C307	1-162-207-31	(MADE IN JAPAN) ...CERAMIC	22PF	5%	50V
C308	1-162-203-31	(MADE IN FRANCE) ...CERAMIC	15PF	5%	50V
C308	1-162-207-31	(MADE IN JAPAN) ...CERAMIC	22PF	5%	50V
C313	1-124-477-11	ELECT	47MF	20%	16V
C314	1-124-477-11	ELECT	47MF	20%	16V
C320	1-136-159-00	FILM	0.033MF	5%	50V
C321	1-130-475-00	MYLAR	0.0022MF	5%	50V
C322	1-130-475-00	MYLAR	0.0022MF	5%	50V
C325	1-130-475-00	MYLAR	0.0022MF	5%	50V
C401	1-124-477-11	ELECT	47MF	20%	16V
C407	1-161-494-00	CERAMIC	0.022MF		25V
C408	1-162-294-31	CERAMIC	0.001MF	10%	50V
C409	1-162-294-31	CERAMIC	0.001MF	10%	50V
C410	1-162-306-11	CERAMIC	0.01MF	20%	16V
C411	1-162-306-11	CERAMIC	0.01MF	20%	16V
C412	1-162-306-11	CERAMIC	0.01MF	20%	16V
C413	1-162-306-11	CERAMIC	0.01MF	20%	16V
C420	1-136-159-00	FILM	0.033MF	5%	50V
C421	1-136-159-00	FILM	0.033MF	5%	50V
C430	1-136-159-00	FILM	0.033MF	5%	50V
C431	1-162-215-31	CERAMIC	47PF	5%	50V
C432	1-162-215-31	CERAMIC	47PF	5%	50V
C433	1-162-215-31	CERAMIC	47PF	5%	50V
C434	1-162-215-31	CERAMIC	47PF	5%	50V
C503	1-164-159-11	CERAMIC	0.1MF		50V
C510	1-162-291-31	CERAMIC	560PF	10%	50V
C511	1-124-478-11	ELECT	100MF	20%	25V
C521	1-126-103-11	ELECT	470MF	20%	16V
C522	1-124-443-00	ELECT	100MF	20%	10V
C550	1-162-291-31	CERAMIC	560PF	10%	50V
C551	1-124-478-11	ELECT	100MF	20%	25V
C570	1-162-291-31	(C305M)...CERAMIC	560PF	10%	50V
C571	1-162-291-31	CERAMIC	560PF	10%	50V
C580	1-162-291-31	(C305M)...CERAMIC	560PF	10%	50V
C581	1-162-291-31	CERAMIC	560PF	10%	50V
C590	1-164-159-11	(C305M)...CERAMIC	0.1MF		50V
C701	1-161-494-00	CERAMIC	0.022MF		25V
C901	1-124-887-00	ELECT	3300MF	20%	16V
C902	1-124-887-00	ELECT	3300MF	20%	16V
C903	1-124-556-11	ELECT	2200MF	20%	16V
C904	1-124-927-11	ELECT	4.7MF	20%	50V
C905	1-123-875-11	ELECT	10MF	20%	50V
C906	1-123-875-11	ELECT	10MF	20%	50V
C908	1-126-176-11	ELECT	220MF	20%	10V
C909	1-124-471-00	ELECT	1000MF	20%	6.3V
C910	1-124-572-11	ELECT	100MF	20%	63V
C912	1-123-875-11	ELECT	10MF	20%	50V
C915	1-126-103-11	ELECT	470MF	20%	16V

Ref.No.	Part No.	Description			
C1001	1-164-159-11	(MADE IN JAPAN)...CERAMIC	0.1MF		50V
C1002	1-164-159-11	(MADE IN JAPAN)...CERAMIC	0.1MF		50V
CN101	*1-564-710-11	PIN, CONNECTOR (SMALL TYPE)			8P
CN103	*1-564-710-11	PIN, CONNECTOR (SMALL TYPE)			8P
CN201	*1-564-706-11	PIN, CONNECTOR (SMALL TYPE)			4P
CN401	*1-564-339-00	(MADE IN JAPAN)...PIN, CONNECTOR			5P
CN401	*1-568-954-11	(MADE IN FRANCE)...PIN, CONNECTOR			5P
CN403	*1-564-500-11	(MADE IN JAPAN)...PIN, CONNECTOR			7P
CN403	*1-568-945-11	(MADE IN FRANCE)...PIN, CONNECTOR			7P
CN407	*1-564-336-00	(MADE IN JAPAN)...PIN, CONNECTOR			2P
CN407	*1-568-951-11	(MADE IN FRANCE)...PIN, CONNECTOR			2P
CN410	*1-564-336-00	(MADE IN JAPAN)...PIN, CONNECTOR			2P
CN410	*1-568-951-11	(MADE IN FRANCE)...PIN, CONNECTOR			2P
CN411	*1-564-337-00	(MADE IN JAPAN)...PIN, CONNECTOR			3P
CN411	*1-568-952-11	(MADE IN FRANCE)...PIN, CONNECTOR			3P
CN412	*1-564-336-71	(MADE IN JAPAN)...PIN, CONNECTOR			2P
CN412	*1-568-951-31	(MADE IN FRANCE)...PIN, CONNECTOR			2P
CN502	*1-564-338-00	(MADE IN JAPAN)...PIN, CONNECTOR			4P
CN502	*1-568-953-11	(MADE IN FRANCE)...PIN, CONNECTOR			4P
CN504	*1-564-498-11	(C301M:MADE IN JAPAN) ...PIN, CONNECTOR			5P
CN504	*1-568-943-11	(C301M:MADE IN FRANCE) ...PIN, CONNECTOR			5P
CN504	*1-564-500-11	(C305M:MADE IN JAPAN) ...PIN, CONNECTOR			7P
CN504	*1-568-945-11	(C305M:MADE IN FRANCE) ...PIN, CONNECTOR			7P
CN505	*1-564-338-00	(MADE IN JAPAN)...PIN, CONNECTOR			4P
CN505	*1-568-953-11	(MADE IN FRANCE)...PIN, CONNECTOR			4P
CN701	*1-564-707-11	PIN, CONNECTOR (SMALL TYPE)			5P
CN902	*1-564-521-11	PLUG, CONNECTOR			6P
CN911	*1-564-336-00	(MADE IN JAPAN)...PIN, CONNECTOR			2P
CN911	*1-568-951-11	(MADE IN FRANCE)...PIN, CONNECTOR			2P
CN1001	*1-564-720-11	PIN, CONNECTOR (SMALL TYPE)			4P
D101	8-719-912-20	DIODE 1SS120			
D301	8-719-912-20	DIODE 1SS120			
D402	8-719-912-20	DIODE 1SS120			
D403	8-719-912-20	DIODE 1SS120			
D404	8-719-912-20	DIODE 1SS120			
D901	△.8-719-200-77	DIODE 10E2N			
D902	△.8-719-200-77	DIODE 10E2N			
D903	△.8-719-200-77	DIODE 10E2N			
D904	△.8-719-200-77	DIODE 10E2N			
D905	△.8-719-200-77	DIODE 10E2N			
D907	8-719-933-46	DIODE HZS781L			
D909	8-719-912-20	DIODE 1SS120			
D910	8-719-912-20	DIODE 1SS120			
D911	8-719-109-81	DIODE RD4.7ES-82			
FL401	1-519-583-11	INDICATOR TUBE, FLUORESCENT			
IC101	8-752-034-00	IC CXA1081S			
IC201	8-752-032-30	IC CXA1082BS			
IC202	8-752-035-28	IC CXA-1291P			
IC203	8-752-035-28	IC CXA-1291P			
IC301	8-752-332-38	IC CXD1125Q			
IC302	8-759-822-79	IC LC3517RM-15			

Note: The components identified by mark **△** or dotted line with mark **△** are critical for safety. Replace only with part number specified.

For Service Manuals Contact
MAURITRON TECHNICAL SERVICES
 8 Cherry Tree Rd, Chinnor
 Oxon OX9 4QY
 Tel: 01844-351694 Fax: 01844-352554
 Email: enquiries@mauritron.co.uk

Ref.No.	Part No.	Description
IC303	8-752-334-06	IC CXD2551P
IC304	8-759-990-13	IC TDA1543A
IC401	8-759-149-46	IC UPD75208CW-A46
IC402	8-749-921-24	IC GPIU52YB
IC501	8-759-945-58	IC RC4558P
IC502	8-759-601-02	(C305M)...IC M5218P
IC701	8-719-970-19	IC GPIA521
IC901	8-759-630-21	IC M5290P-16
IC902	8-759-633-42	IC M5293L
J507	1-568-519-21	(C305M)...JACK, LARGE TYPE (HEADPHONES)
J551	1-569-442-11	JACK, PIN 2P (LINE OUT)
L301	*1-410-858-11	INDUCTOR OUH
LP2	*4-352-844-01	PIN, LEAD, COATING
M401	A-4608-350-A	(MADE IN JAPAN)...MOTOR ASSY, LOADING
M401	X-4604-554-A	(MADE IN FRANCE)...MOTOR ASSY, LOADING
M701	A-4604-585-A	(MADE IN JAPAN)...MOTOR ASSY, ROTARY
M701	X-4604-572-A	(MADE IN FRANCE)...MOTOR ASSY, ROTARY
M902	X-4917-504-1	MOTOR ASSY (SLED)
PS901A	1-532-637-00	LINK, IC
PS902A	1-532-637-00	LINK, IC
Q101	8-729-801-84	TRANSISTOR 2SB1013-4
Q201	8-729-900-89	TRANSISTOR DTC144ES
Q202	8-729-900-80	TRANSISTOR DTC114ES
Q301	8-729-900-89	TRANSISTOR DTC144ES
Q302	8-729-900-65	TRANSISTOR DTA144ES
Q401	8-729-900-36	TRANSISTOR DTC124ES
Q510	8-729-900-74	TRANSISTOR DTC143TS
Q513	8-729-900-74	(C305M)...TRANSISTOR DTC143TS
Q550	8-729-900-74	TRANSISTOR DTC143TS
Q553	8-729-900-74	(C305M)...TRANSISTOR DTC143TS
Q901	8-729-140-96	TRANSISTOR 2SD774-34
Q902	8-729-111-67	TRANSISTOR 2SB1094-L
Q903	8-729-119-76	TRANSISTOR 2SA1175-HFE
R101	1-249-397-11	CARBON 22 5% 1/4W
R102	1-247-806-11	CARBON 91 5% 1/4W
R103	1-249-417-11	CARBON 1K 5% 1/4W
R104	1-249-433-11	CARBON 22K 5% 1/4W
R105	1-247-864-11	CARBON 24K 5% 1/4W
R106	1-249-441-11	CARBON 100K 5% 1/4W
R107	1-249-417-11	CARBON 1K 5% 1/4W
R108	1-249-431-11	CARBON 15K 5% 1/4W
R109	1-249-431-11	CARBON 15K 5% 1/4W
R110	1-249-425-11	CARBON 4.7K 5% 1/4W
R111	1-249-425-11	CARBON 4.7K 5% 1/4W
R201	1-249-429-11	CARBON 10K 5% 1/4W
R202	1-249-433-11	CARBON 22K 5% 1/4W
R203	1-249-414-11	CARBON 560 5% 1/4W
R204	1-249-441-11	CARBON 100K 5% 1/4W
R205	1-215-434-00	(MADE IN JAPAN)...METAL 3.6K 1% 1/6W
R205	1-247-844-11	(MADE IN FRANCE)...CARBON 3.6K 5% 1/4W
R206	1-249-441-11	CARBON 100K 5% 1/4W
R207	1-249-440-11	CARBON 82K 5% 1/4W
R208	1-247-889-00	CARBON 270K 5% 1/4W

Ref.No.	Part No.	Description
R209	1-249-435-11	CARBON 33K 5% 1/4W
R210	1-247-896-11	CARBON 510K 5% 1/4W
R211	1-249-427-11	CARBON 6.8K 5% 1/4W
R212	1-247-881-00	CARBON 120K 5% 1/4W
R213	1-249-423-11	CARBON 3.3K 5% 1/4W
R214	1-249-425-11	CARBON 4.7K 5% 1/4W
R215	1-247-882-11	CARBON 130K 5% 1/4W
R216	1-249-432-11	CARBON 18K 5% 1/4W
R217	1-249-432-11	CARBON 18K 5% 1/4W
R218	1-249-437-11	CARBON 47K 5% 1/4W
R219	1-249-435-11	CARBON 33K 5% 1/4W
R220	1-249-417-11	CARBON 1K 5% 1/4W
R221	1-249-393-11	CARBON 10 5% 1/4W
R222	1-249-393-11	CARBON 10 5% 1/4W
R223	1-249-441-11	CARBON 100K 5% 1/4W
R250	1-249-393-11	(MADE IN FRANCE)...CARBON 10 5% 1/4
R251	1-249-393-11	(MADE IN FRANCE)...CARBON 10 5% 1/4
R301	1-215-469-00	(MADE IN JAPAN)...METAL 100K 1% 1/6
R301	1-249-441-11	(MADE IN FRANCE)...CARBON 100K 5% 1/4
R302	1-215-469-00	(MADE IN JAPAN)...METAL 100K 1% 1/6
R302	1-249-441-11	(MADE IN FRANCE)...CARBON 100K 5% 1/4
R303	1-249-429-11	CARBON 10K 5% 1/4W
R304	1-249-441-11	CARBON 100K 5% 1/4W
R305	1-249-429-11	CARBON 10K 5% 1/4W
R306	1-249-433-11	CARBON 22K 5% 1/4W
R307	1-247-903-00	CARBON 1M 5% 1/4W
R308	1-249-417-11	CARBON 1K 5% 1/4W
R309	1-249-417-11	CARBON 1K 5% 1/4W
R310	1-249-413-11	CARBON 470 5% 1/4W
R311	1-249-417-11	CARBON 1K 5% 1/4W
R312	1-249-415-11	CARBON 680 5% 1/4W
R313	1-249-417-11	CARBON 1K 5% 1/4W
R320	1-249-417-11	CARBON 1K 5% 1/4W
R401	1-249-429-11	CARBON 10K 5% 1/4W
R403	1-249-429-11	CARBON 10K 5% 1/4W
R404	1-249-439-11	CARBON 68K 5% 1/4W
R405	1-249-429-11	CARBON 10K 5% 1/4W
R406	1-249-429-11	CARBON 10K 5% 1/4W
R407	1-249-429-11	CARBON 10K 5% 1/4W
R408	1-249-433-11	CARBON 22K 5% 1/4W
R409	1-249-433-11	CARBON 22K 5% 1/4W
R410	1-249-433-11	CARBON 22K 5% 1/4W
R411	1-249-433-11	CARBON 22K 5% 1/4W
R412	1-247-889-00	CARBON 270K 5% 1/4W
R413	1-247-884-11	CARBON 160K 5% 1/4W
R414	1-247-889-00	CARBON 270K 5% 1/4W
R415	1-247-883-00	CARBON 150K 5% 1/4W
R416	1-247-881-00	CARBON 120K 5% 1/4W
R417	1-247-883-00	CARBON 150K 5% 1/4W
R418	1-247-882-11	CARBON 130K 5% 1/4W
R419	1-247-883-00	CARBON 150K 5% 1/4W
R420	1-249-429-11	CARBON 10K 5% 1/4W
R421	1-249-429-11	CARBON 10K 5% 1/4W
R422	1-249-429-11	CARBON 10K 5% 1/4W

Note: The components identified by mark Δ or dotted line with mark Δ are critical for safety. Replace only with part number specified.

Ref.No.	Part No.	Description			
R423	1-249-429-11	CARBON	10K	5%	1/4W
R424	1-249-429-11	CARBON	10K	5%	1/4W
R425	1-249-417-11	CARBON	1K	5%	1/4W
R430	1-249-433-11	CARBON	22K	5%	1/4W
R431	1-249-433-11	CARBON	22K	5%	1/4W
R501	1-249-437-11	CARBON	47K	5%	1/4W
R503	1-249-421-11	CARBON	2.2K	5%	1/4W
R504	1-249-441-11	CARBON	100K	5%	1/4W
R510	1-249-422-11	CARBON	2.7K	5%	1/4W
R511	1-247-891-00	CARBON	330K	5%	1/4W
R512	1-249-419-11	CARBON	1.5K	5%	1/4W
R514	1-249-405-11	CARBON	100	5%	1/4W
R515	1-249-402-11	(C305M)...CARBON	56	5%	1/4W
R550	1-249-422-11	CARBON	2.7K	5%	1/4W
R551	1-247-891-00	CARBON	330K	5%	1/4W
R552	1-249-419-11	CARBON	1.5K	5%	1/4W
R554	1-249-405-11	CARBON	100	5%	1/4W
R555	1-249-402-11	(C305M)...CARBON	56	5%	1/4W
R701	1-249-416-11	CARBON	820	5%	1/4W
R901	1-249-437-11	CARBON	47K	5%	1/4W
R902	1-249-429-11	CARBON	10K	5%	1/4W
R903	1-249-438-11	CARBON	56K	5%	1/4W
R904	1-249-425-11	CARBON	4.7K	5%	1/4W
R905	1-249-425-11	CARBON	4.7K	5%	1/4W
R906	1-249-410-11	CARBON	270	5%	1/4W
R914	1-249-423-11	CARBON	3.3K	5%	1/4W
R1001	1-249-393-11	(MADE IN JAPAN)...CARBON	10	5%	1/4W
R1002	1-249-393-11	(MADE IN JAPAN)...CARBON	10	5%	1/4W
RV1	1-228-995-00	RES, ADJ, CARBON 22K			
RV2	1-228-993-00	RES, ADJ, CARBON 4.7K			
RV3	1-228-995-00	RES, ADJ, CARBON 22K			
RV4	1-228-995-00	RES, ADJ, CARBON 22K			
RV5	1-228-990-00	RES, ADJ, METAL GLAZE 1K			
RV501	1-241-031-11	(C305M)...RES, VAR, CARBON 1K/1K(LEVEL)			
S1	1-554-303-21	SWITCH, KEY BOARD (CONTINUE)			
S2	1-554-303-21	SWITCH, KEY BOARD (SHUFFLE)			
S3	1-554-303-21	SWITCH, KEY BOARD (PROGRAM)			
S4	1-554-303-21	SWITCH, KEY BOARD (TIME)			
S5	1-554-303-21	SWITCH, KEY BOARD (▶▶)			
S6	1-554-303-21	SWITCH, KEY BOARD (◀◀)			
S7	1-554-303-21	SWITCH, KEY BOARD (■)			
S8	1-554-303-21	SWITCH, KEY BOARD (▶)			
S9	1-554-303-21	SWITCH, KEY BOARD (OPEN/CLOSE)			
S10	1-554-303-21	SWITCH, KEY BOARD (DISK SKIP)			
S11	1-554-303-21	SWITCH, KEY BOARD (REPEAT)			
S12	1-554-303-21	SWITCH, KEY BOARD (TIME FADE)			

Ref.No.	Part No.	Description
S401	1-571-677-11	SWITCH, PUSH (1 KEY)(CLOSE)
S402	1-571-300-11	SWITCH, ROTARY (OPEN/BU-UP)
S403	1-571-453-11	SWITCH, LEVER SLIDE (BM-DOWN)
S404	1-570-822-11	SWITCH, LEAF (LIMIT IN)
S901	△.1-571-305-11	SWITCH, PUSH (1 KEY)(POWER)
S902	1-570-707-21	SWITCH, SLIDE (TIMER)
S910	△.1-571-722-11	(E)...SWITCH, VOLTAGE SELECTION (VOLTAGE SELECTOR)
T901	△.1-449-957-11	(AEP,UK:MADE IN FRANCE) ...TRANSFORMER, POWER
T901	△.1-449-959-11	(E).....TRANSFORMER, POWER
T901	△.1-449-960-11	(AEP,UK,Australian:MADE IN JAPAN) ...TRANSFORMER, POWER
T901	△.1-450-136-11	(US).....TRANSFORMER, POWER
X301	1-567-908-11	(MADE IN JAPAN)...VIBRATOR, CRYSTAL 16.9MHz
X301	1-577-328-11	(MADE IN FRANCE)...VIBRATOR, CRYSTAL 16.9MHz
X401	1-577-358-21	VIBRATOR, CERAMIC 4MHz

ACCESSORY & PACKING MATERIAL

1-559-533-11	CORD, CONNECTION
3-751-430-11	(AEP,E,Australian:MADE IN JAPAN) ...MANUAL, INSTRUCTION
3-751-430-21	(C301M:US).....MANUAL, INSTRUCTION
3-751-430-41	(AEP:MADE IN JAPAN)...MANUAL, INSTRUCTION
3-751-430-51	(AEP,UK:MADE IN FRANCE) ...MANUAL, INSTRUCTION
3-751-430-61	(AEP:MADE IN FRANCE)...MANUAL, INSTRUCTION
*3-795-629-11	(AEP:MADE IN JAPAN)...INSTRUCTION
*3-795-629-41	(AEP:MADE IN FRANCE)...INSTRUCTION
*4-930-516-01	(MADE IN JAPAN)...CUSHION (LEFT)
*4-930-517-01	(MADE IN JAPAN)...CUSHION (RIGHT)
*4-930-962-01	(MADE IN FRANCE)...CUSHION (FRONT)
*4-930-962-01	(MADE IN FRANCE)...CUSHION (REAR)
*4-937-960-01	(C305M:MADE IN FRANCE)...INDIVIDUAL CARTON
*4-937-961-01	(C305M:MADE IN JAPAN)...INDIVIDUAL CARTON
*4-937-960-11	(C301M:MADE IN FRANCE)...INDIVIDUAL CARTON
*4-937-961-11	(C301M:MADE IN JAPAN)...INDIVIDUAL CARTON

Note: The components identified by mark Δ or dotted line with mark Δ are critical for safety. Replace only with part number specified.