

JVC

SERVICE MANUAL

MODEL

KD-A11 A/B/C/E/J/U

STEREO CASSETTE DECK

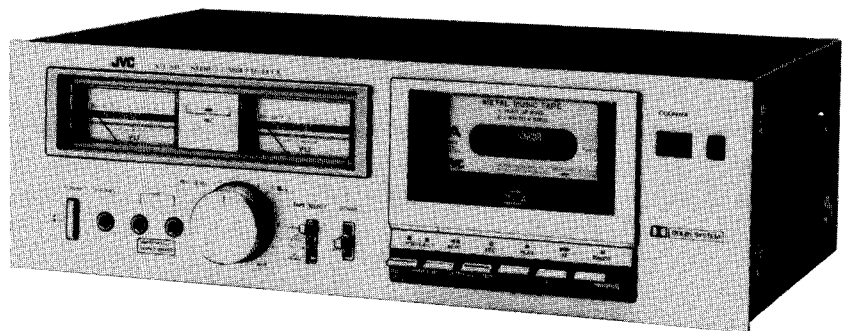

No. 4192
June 1980

Contents

	Page
Specifications	2
Features	3
Controls and Connections	3
Main Parts Location	4
Maintenance	5
Removal of the Main Parts	5
Main Adjustments	9
Integrant Circuit	13
Block Diagram	14
Wiring Connection	15
Standard Schematic Diagram	16
Mechanical Component Parts	17
Mechanical Component Parts List	18
Enclosure Assembly and Electrical Parts List	21
Enclosure Assembly and Electrical Parts	23
Main Amp P.W. Board Parts	24
Main Amp P.W. Board Parts List	25
Other P.W. Board Parts List	28
Packing, Packing Material List	28
Accessories	29

Specifications

Type	: Stereo cassette deck	Motor	: Electronic governed DC motor
Track system	: 4-track, 2-channel	Fast forward time	: 95 sec. with C-60 cassette
Tape speed	: 1-7/8 inch/sec (4.8 cm/sec)	Rewind time	: 95 sec. with C-60 cassette
Frequency response:		Semiconductors	: 3 ICs, 21 transistors, 17 diodes 1 LED
(0 VU recording)		Input terminals	:
Metal tape	* 1 ; 40–11,000 Hz (± 3 dB)	Mic jack x 2	: Max. sensitivity; 0.2mV (-72 dBs) Matching impedance; 600Ω – 10kΩ
SA/Chrome tape	* 2 ; 40–8,000 Hz (± 3 dB)	Input jack x 2	: Min. input level; 80mV (-20 dBs) Input impedance; 100kΩ
SF/Normal tape	* 3 ; 40–8,000 Hz (± 3 dB)	Output terminals	:
(-20 VU recording)		Output jack x 2	: Output level; 300mV Output impedance; 5kΩ
Metal tape	* 1 ; 30–16,000 Hz 40–15,000 Hz (± 3 dB)	Phones jack x 1	: Output level; 0.3mW (8Ω) Matching impedance; 8Ω – 1kΩ
SA/Chrome tape	* 2 ; 30–16,000 Hz 40–15,000 Hz (± 3 dB)	DIN socket	: Min. input level; 0.1mV/kΩ Input impedance; 10kΩ Output level; 380mV Output impedance; 5kΩ
SF/Normal tape	* 3 ; 30–15,000 Hz 40–14,000 Hz (± 3 dB)	Power requirement	: AC 240V, 50Hz (KD-A11A) AC 240/220/120V, 50/60Hz (KD-A11B/C/E/J) AC 240/220/120/100V, 50/60 Hz (KD-A11U)
Surpasses DIN 45 500		Power consumption	: 10W
Note: *1 ... SCOTCH METAFINE or Equivalent		Dimensions	: 16-1/2" (420 mm)W 5-1/4" (134 mm)H 10-3/8" (264mm)D
*2 ... TDK SA or Equivalent		Weight	: 9.9 lbs (4.5 kg)
*3 ... MAXELL UD or Equivalent		Design and specifications are subject to change without notice.	
S/N ratio	: 60 dB (from peak level, weighted, Metal tape) The S/N is improved by 5 dB at 1 kHz and by 10 dB above 5 kHz with DOLBY N.R. on (DIN 45 500 weighted)		
Wow and flutter	: 0.05% (WRMS), 0.15% (DIN 45 500)		
Crosstalk	: 65 dB (1 kHz)		
Harmonic distortion	: K3; 0.5%, THD; 1.0% (metal tape, 1 kHz 0 VU)		
Bias	: AC bias		
Erasure	: AC erasure		
Heads	: 2 heads METAPERM head for recording/ playback and 2-gap ferrite head for erasure		

Features

- Single lever 4-stage tape select switch makes the KD-A11 compatible with all types of tape including the new metal Tape format.
- **IC-built Dolby*Noise Reduction System**
Dolby System greatly improves performance by cutting out tape hiss, without changing the original music, thus making it every bit as good as professional standard type open reel tapes. High reliability and optimum quality

are assured through employment of IC-built circuitry. (Dolby* is trademark of Dolby Laboratories Inc.)
(Noise Reduction System manufactured under license, from Dolby Laboratories Inc.)

- METAPERM head for recording/playback
- 2 Gap ferrite head for erasure
- Automatic input select

Controls and Connections

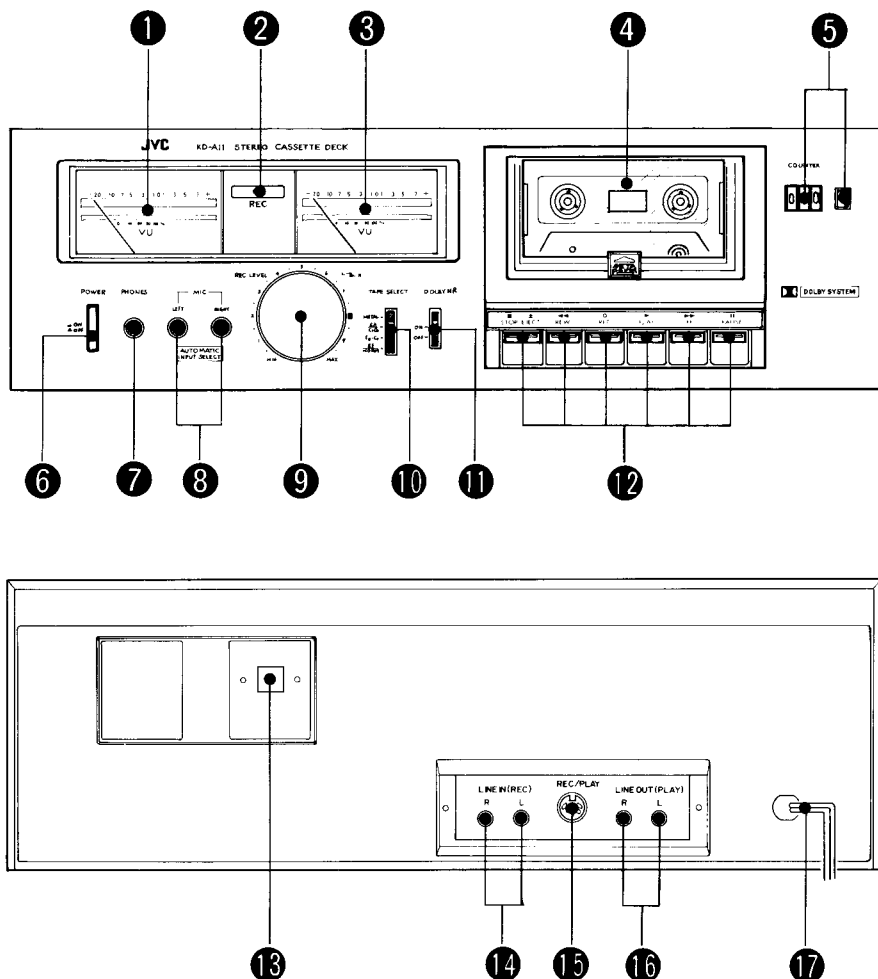

- ① ③ VU meters
- ② Recording indicator (REC)
- ④ Cassette holder
- ⑤ Tape COUNTER/counter reset button
- ⑥ POWER switch
- ⑦ PHONES jack
- ⑧ MIC jacks
- ⑨ REC LEVEL controls
- ⑩ TAPE SELECT switch
- ⑪ Dolby noise reduction switch (DOLBY NR)

- ⑫ Cassette operation buttons.
 - ▲ STOP/EJECT button
 - ◀◀ REWIND button
 - Record button (REC)
 - ▶▶ PLAY button
 - ▶▶ FF button
 - || PAUSE button
- ⑬ Voltage select switch (KD-A11 B/C/E/J/U)
- ⑭ LINE IN (REC) terminals
- ⑮ DIN (REC/PLAY) socket
- ⑯ LINE OUT (PLAY) terminals
- ⑰ Power cord

Main Parts Location

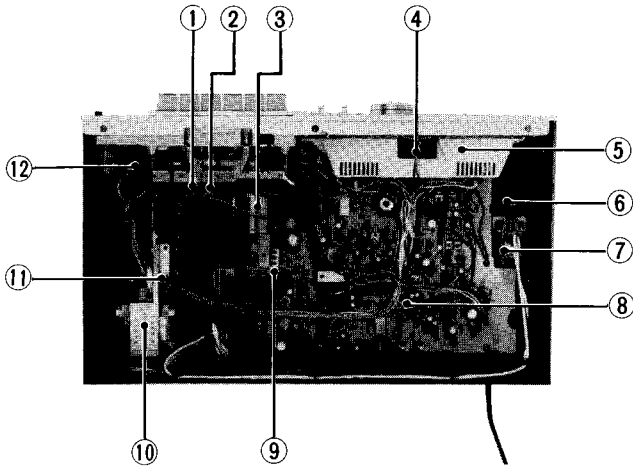

1. Flywheel/capstan belt
2. Auto stop solenoid
3. Motor
4. Recording indicator P.W.B.
5. Meter cover
6. Remote bar
7. Power switch P.W.B.
8. Main Amp P.W.B.
9. Recording spring
10. Power Transformer
11. Oiled-gear damper assembly
12. Reed switch P.W.B.

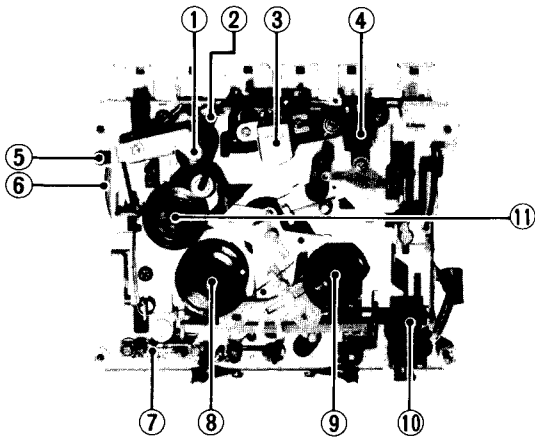

(Mechanical parts)

1. Pinch roller arm assembly
2. Pinch roller spring
3. REC/PB Head
4. Erase Head
5. Pause switch
6. Flywheel
7. Motor switch
8. Take up reel disc ass'y
9. Supply reel disc ass'y
10. Recording safety lever
11. Take up idler assembly
12. Stop/eject bar assembly
13. Rewind bar assembly
14. Recording bar assembly
15. Play bar assembly
16. Fast forward bar assembly
17. Pause bar assembly
18. Motor
19. Flywheel/Motor bracket

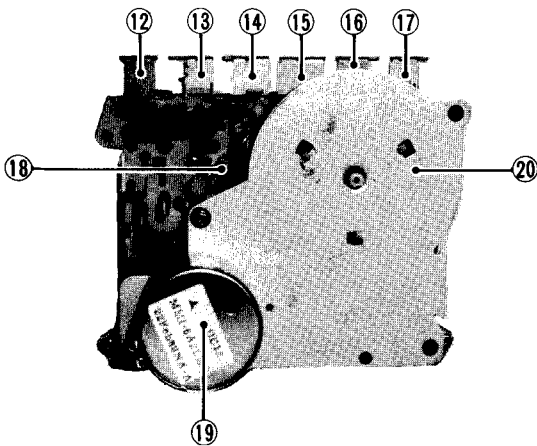

Maintenance

To get long, trouble-free service, maintenance is important. Do not forget cleaning and demagnetizing.

Cleaning

After long use, the heads and tape part — capstan, pinch roller, etc. — will become dirty with dust or magnetic particles. Dirty heads cause imperfect erasing or high frequency drop-off. A dirty capstan and pinch roller will cause unstable tape speed, leading to increased wow and flutter. Always keep them clean by following the procedure below.

1. Heads

- 1) Push Eject button to open the cassette holder.
- 2) Use the head cleaning stick provided to wipe the surface where the tape comes into contact with the head.
(It is effective to moisten the cotton with alcohol.)

2. Pinch roller and capstan

Do the same method as heads.

3. Cabinet

When the cabinet becomes dirty, wipe it with a soft cloth soaked with a neutral cleaning solution or a polishing cloth.

- * Do not use thinner or benzine.

Demagnetizing

The heads are made from a material resistant to magnetization, but after long use they become magnetized. A magnet brought into their vicinity can magnetize the heads, causing excess noise. If noise seems to have increased, demagnetize the heads with a head demagnetizer through the following procedure.

1. Turn the POWER switch OFF.
 2. Wrap the tip of the demagnetizer with vinyl tape or soft cloth so as not to damage the head surface. Switch on the demagnetizer and bring it close to the head.
 3. Move the tip of the demagnetizer slowly first to the left and right, then up and down in front of the head. Gradually move it away from the head and switch it off at a distance of more than 30 cm. (12")
 4. The erase head need not be demagnetized. The capstan shaft and tape guide should be demagnetized in the same way as the record/playback head.
- * Do not bring a magnetized metallic object (a screwdriver, for example) near the head as this will increase noise.

Removal of the Main Parts

Observe care in handling the parts since the parts are small in size and the distance between them are short due to a deck design aimed mainly at compactness and high performance.

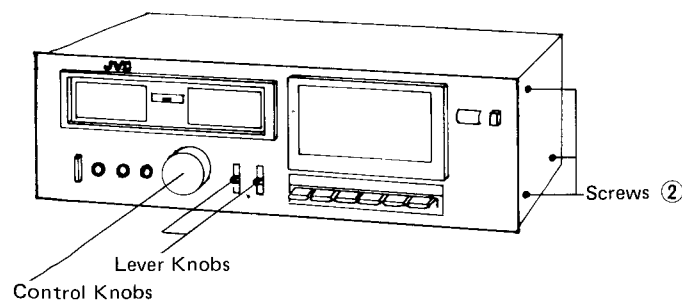
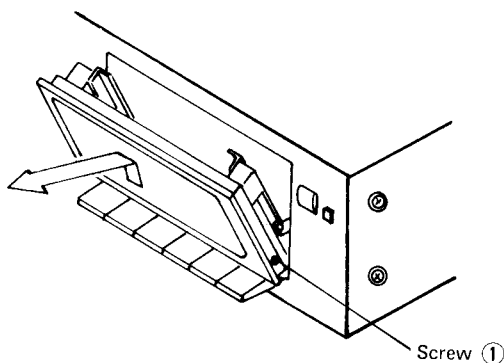

ENCLOSURE ASSEMBLY PARTS

Cassette lid

- 1) To open the cassette lid, push on the eject lever.
Remove a screw ① fastening the cassette lid. (its right low side)
Be careful of holding a nut.
- 2) Pull off the cassette lid to upper side.

Top cover

Remove 6 screws (left and right 3 screws ② on each)

Control knobs (REC LEVEL)

Pull off them to forward.

Lever knobs (TAPE SELECT, DOLBY NR)

Pull off them to forward.

Bottom cover

Remove 3 screws fastening the bottom cover. (center screw is long size.)

Remove the bottom cover from 3 pawls of mold chassis.

Front plate assembly

Remove 5 screws (3 screws ③ on upper side and 2 screws ④ on bottom side.) fastening the front plate assembly.

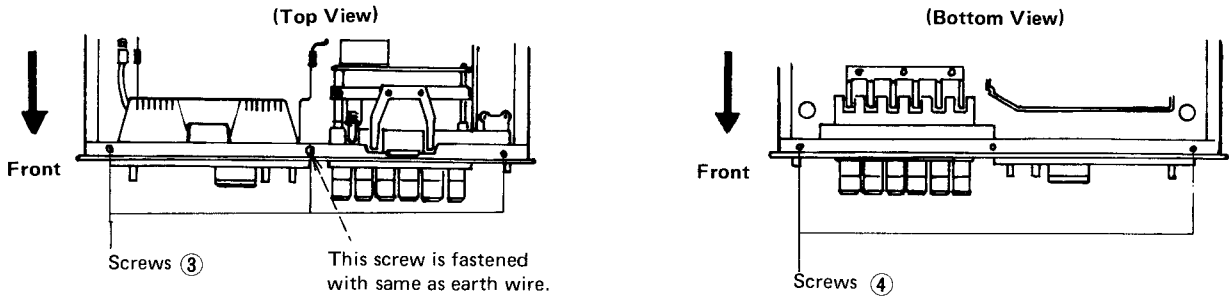

Front panel assembly

1. Remove a screw ⑤ fastening the button escutcheon ass'y (left side)
2. Open the cassette holder, and remove a screw fastening the arm ass'y for oiled-gear damper.
3. Remove 4 screws ⑥ fastening the front panel. (left and right 2 screws on each)

4. Remove a washer and a nut ⑦ fastening the REC LEVEL control VR shaft.
5. Remove a screw ⑧ fastening the lever switch on main amp P.W. Board ass'y. (Mechanical assembly is removed with the same as front panel.)

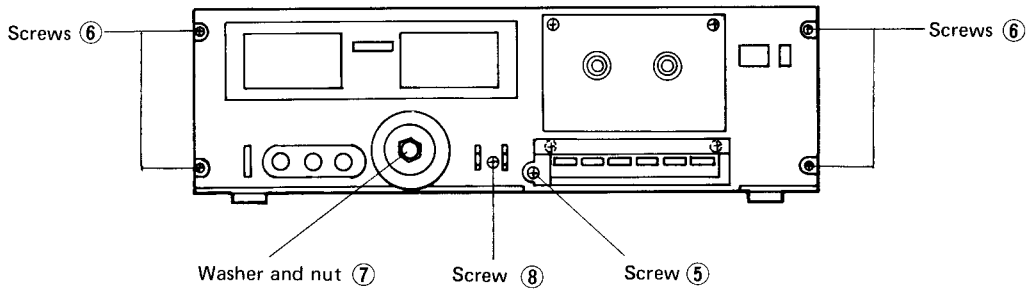

MECHANICAL ASSEMBLY

1. Remove the counter belt from counter.
2. Remove 4 screws ⑨ fastening the front panel.

If you remove the mechanical assembly with not removed the front panel, do the following method.

- 1) Remove the mecha control plate.

- 2) Remove 4 screws ⑨ fastening the front plate. (When assembling the mechanical control plate, it need a new parts = the mechanical control plate cannot use again.)

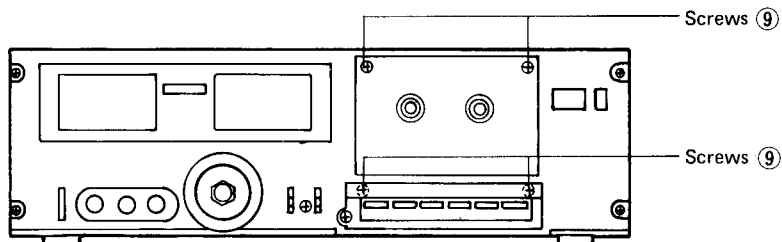

ELECTRICAL PARTS (Main amp P.W. Board ass'y)

- 1) Remove a nut and a washer fastening the REC LEVEL control VR shaft.
- 2) Remove a screw fastening the lever switch.
- 3) Remove 3 screws fastening the main amp P.W. Board.
- 4) Remove 2 plastic rivets fastening the PIN jack assembly.
- 5) Remove the record spring.
- 6) Remove 4 pawls for holding the main amp P.W. Board.

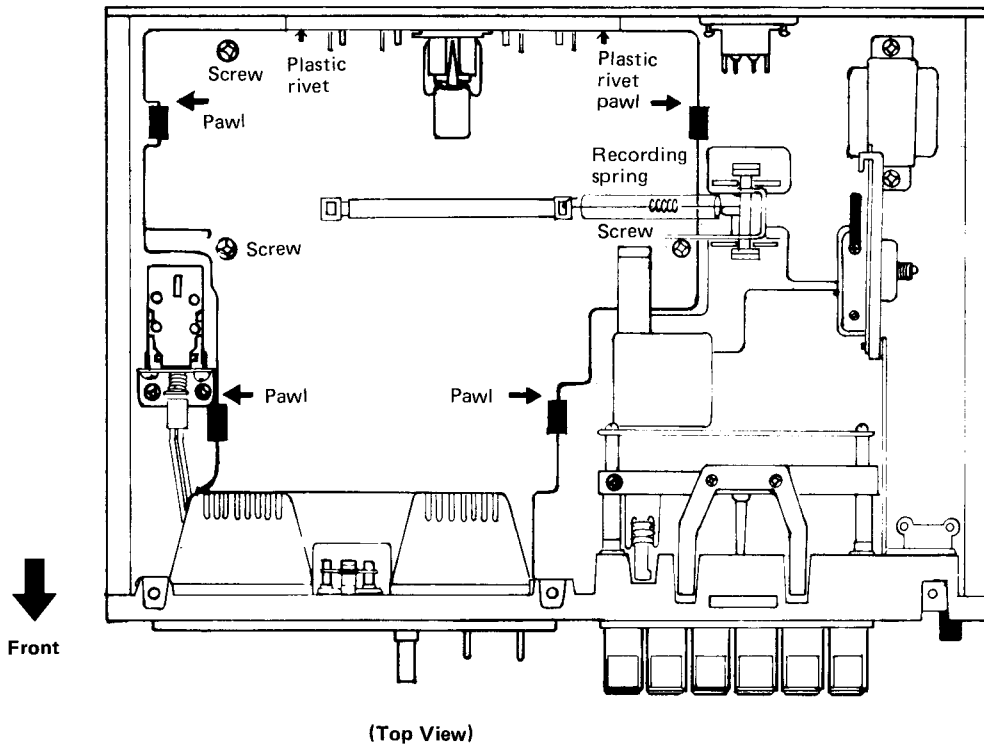

MECHANICAL PARTS

1. REC/PB head
Remove a screw ①
Remove a screw ② for adjustment.
 2. Erase head
Remove a screw ③
Remove a screw ④ for adjustment.
 3. Pinch roller arm ass'y
Remove an E-ring ⑤ holding its assembly.
Pull it off from the shaft.
 4. Supply reel disc
Pull out the reel disc stopper ⑥ and pull out its disc from shaft.
 5. Take-up reel disc
Pull out the reel disc stopper ⑦ and remove the counter belt, pull out its disc from shaft.
- Note:** (1) Remove the reel disc stoppers with a piece of sheet metal inserted between the reel disc and the stopper. (When assembling the reel disk, the stopper need a new parts. (the stopper can not use again.)
(2) Be careful not to stain the counter belt.

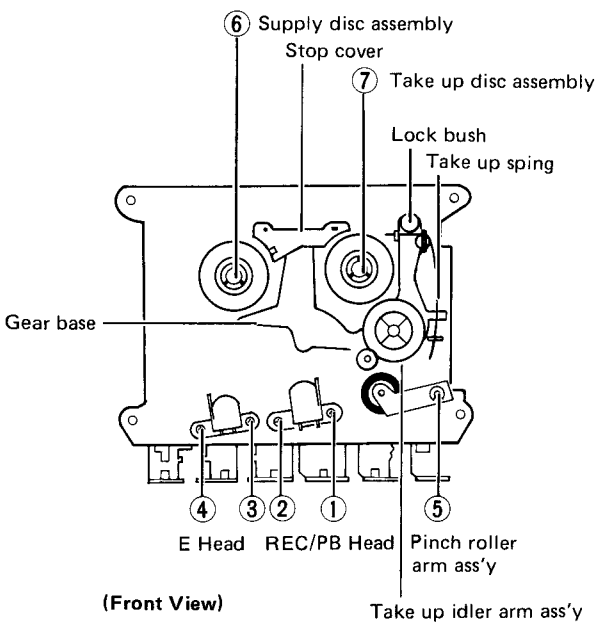

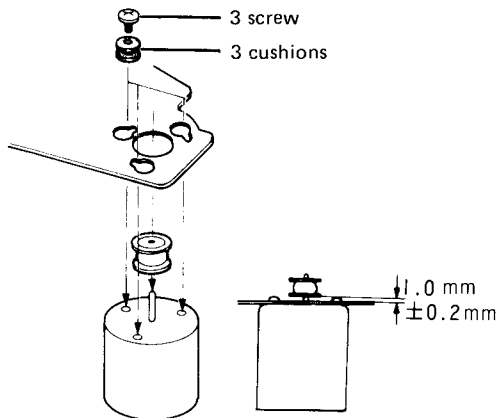
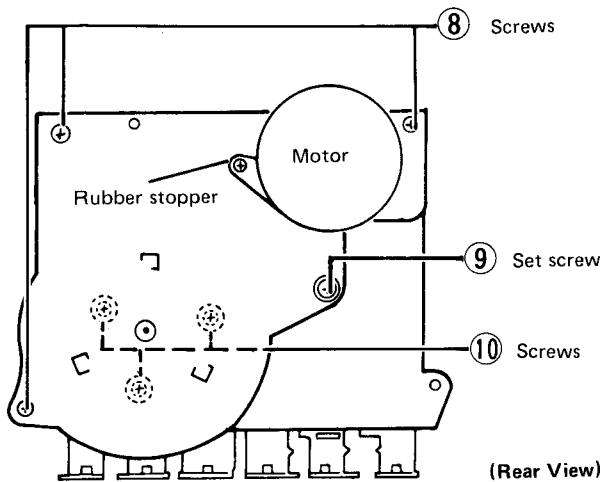

Flywheel assembly

1. Remove 3 screws ⑧ and a set screw ⑨ fastening the flywheel and motor bracket.
2. Remove a capstan belt.
3. Remove 3 screws fastening the capstan metal.
4. Remove the pressure lock bushing and the take up spring on front side, and then remove the take up idler arm assembly.
5. Remove the pressure position of stopper cover, and move the gear base to supply disc direction, and then remove the gear base tip from the groove of capstan metal.
6. Pull off the flywheel assembly.

Note: When assembling the flywheel, fasten the screws after assembled the chassis to the groove of capstan metal.

Motor

- 1) Remove a screw fastening the rubber stopper.
- 2) Remove the capstan belt from the motor pulley.
- 3) To remove the motor, turn it in counter-clockwise direction and pull it out backward (with 3 cushions and 3 screws for fastening the motor).

Note: When replacing the motor, check the following points.

- (1) Is the motor placed in correct position?
(Don't make the motor's position deflective.)
- (2) Does the capstan belt run in the center of the motor pulley?

DOOR BRAKE AND ITS RELATED PARTS

1. Gear frame ass'y Remove a screw ①.
2. Brake arm and tire Remove the E-ring and torsion spring ②.
3. Spur gear and brake drum Remove the E-ring, and spring ③.
4. Rack plate Remove the screw and the collar ④.
5. Brake lever ass'y Remove the E-ring ⑤.

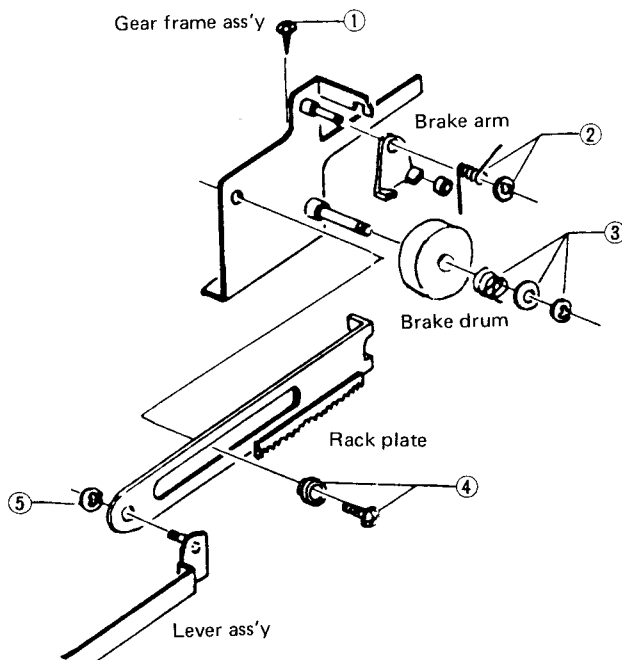

Main Adjustments

[I] Equipment and measuring instruments used for adjustment.

1. Electrical adjustment

- 1) Electronic voltmeter
- 2) Audio frequency oscillator
(range; 50–20 kHz and output 0 dB with impedance 600 Ω)
- 3) Attenuator
- 4) Standard tapes for REC/PB
SONY CS-30 – FeCr tape
BASF T308S – NORMAL tape
BASF C401R – CrO₂ tape
SCOTCH METAFINE – METAL tape } or equivalent
- 5) Reference tapes for playback (JVC Test Tape)
VTT-658 (for head azimuth adj.)
VTT-656 (for motor speed, wow flutter adj.)
VTT-664 (for Reference level 1 kHz)
VTT-675N (for playback frequency response)
- 6) Resistors
100 Ω (for measurement of the bias current)
600 Ω (for attenuator matching)

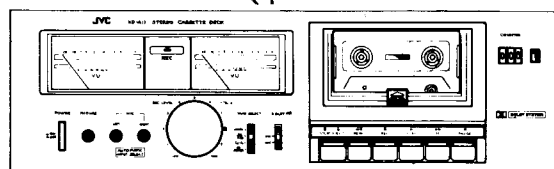
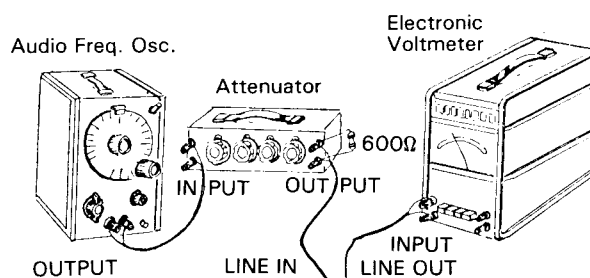

KD-A11

2. Mechanical adjustment

- 1) Gauge for checking the head position.
- 2) Torque gauge
- 3) Blank tape (C-120) for tape running checker.

[II] Adjustment and repair of the mechanism

(Adjust the mechanism or confirm that it is in normal operating condition prior to the adjustment of the electrical circuit.)

Item	Adjustment	Adjusting point	Standard value	Remarks
Adjusting record/playback head position 	<ol style="list-style-type: none"> 1. Connect an electronic voltmeter to the LINE OUT terminals. 2. Play back the VTT-658 test tape. 3. Adjust the head angle with the screw (A) until the reading of the electronic voltmeter becomes maximum for both channels. 4. After adjusting, set the screw with screw bond. 	Screw (A)	Maximum	<ol style="list-style-type: none"> 1. If the head is worn, disconnected or exceedingly magnetized so as not to provide the necessary characteristics, replace it with a new one. After replacement, the head position adjustment as well as the playback level adjustment, the bias current adjustment and the recording level adjustment are all necessary. 2. If the output difference between the left and right channels exceeds 3–4 dB, the head is defective. Replace it with a new one.
Adjusting erase head height 	Tape-to-head contact adjustment <ol style="list-style-type: none"> 1. Turn the adjusting screw (D) for aligning the erase head until it stops. Then, turn the screw (D) in the reverse direction by 180° (a ½ revolution). 2. Employ a special cassette (C-120) from which parts to the casing, where the erase head, record/playback head and capstan engage, has been cut away. Perform tape transport with the cassette tape. Adjust the screw (C) until the tape runs in the center of the erase head tape guide. 3. Check it again with a BASF C401R-CrO₂ tape. Checking method: Record a 400 Hz or 1 kHz signal with 0VU+20dB. Erase the recording. Check if the erasing is satisfactorily performed. 4. After adjustment, apply screw bond on the adjusting screw to prevent its loosening. 	Screw (C)		

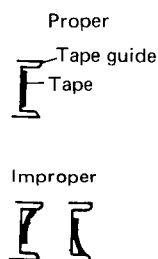

Item	Adjustment	Adjusting point	Standard value	Remarks
Adjusting motor speed	Connect a speed meter to the LINE OUT terminals. Play back the VTT-656 test tape. Adjust the semi-fixed resistor in the motor until the reading of the speed meter is 3000 Hz.	Semi-fixed resistor in the motor	3000 Hz	If the speed meter functions as a wow and flutter meter, also, connect the deck to the INPUT terminals of the meter.
Checking play-back torque	Employ a torque testing cassette tape for the checking, or remove the cassette cover and use a torque gauge.		40 ~ 70 gr-cm	If the standard torque is not obtained, replace the take-up reel disc assembly.
Checking fast forward torque	Measure the torque in the fast forward mode in the same manner as in the above.		More than 80 gr-cm	If the standard torque is not obtained, perform the following. 1. Clean the capstan belt, the idler circumference, the motor pulley, the take-up reel disc circumference, the flywheel circumference, etc. 2. Replace the capstan belt or idler ass'y.
Checking rewind torque	Measure the torque in the rewind mode in the same manner as in the above.		More than 80 gr-cm	If the standard torque is not obtained, clean the capstan belt, idler, motor pulley, flywheel circumference, supply reel disc circumference, etc.

[III] Repair of wow flutter

If wow and flutter increase, check the following points. If there is defect in revolving parts, the wow and flutter generated will increase in proportion to the number of revolu-

tions.

Play a 3000 Hz test tape, and defective part can be detected from the sound.

Section	Trouble	Repair
Capstan and flywheel	Capstan shaft has excessive run-out. Flywheel turns heavily. (shaft seizure, thrust play, etc.)	Replace flywheel. Clean the capstan shaft in the flywheel. Replace the capstan assembly.
Pinch roller	Rough rotation (Deformation scratches, or dust) The angular position of the pinch roller is not correct. The pinch roller pressure is not correct.	Replace pinch roller, or pinch roller spring. Clean the pinch roller. Adjust the pinch roller so that it is parallel with the capstan shaft.
Belt	Belt has undue run-out. Belt is dirty or slippery.	Check the belt. Replace the belt.
Back tension	Back tension is irregular, or back tension is too strong.	Replace back compression spring (under supply disc).
Motor	Motor shaft has undue run-out. Motor pulley is oily and dusty.	Replace motor. Clean motor pulley.

[IV] Electrical adjustments location

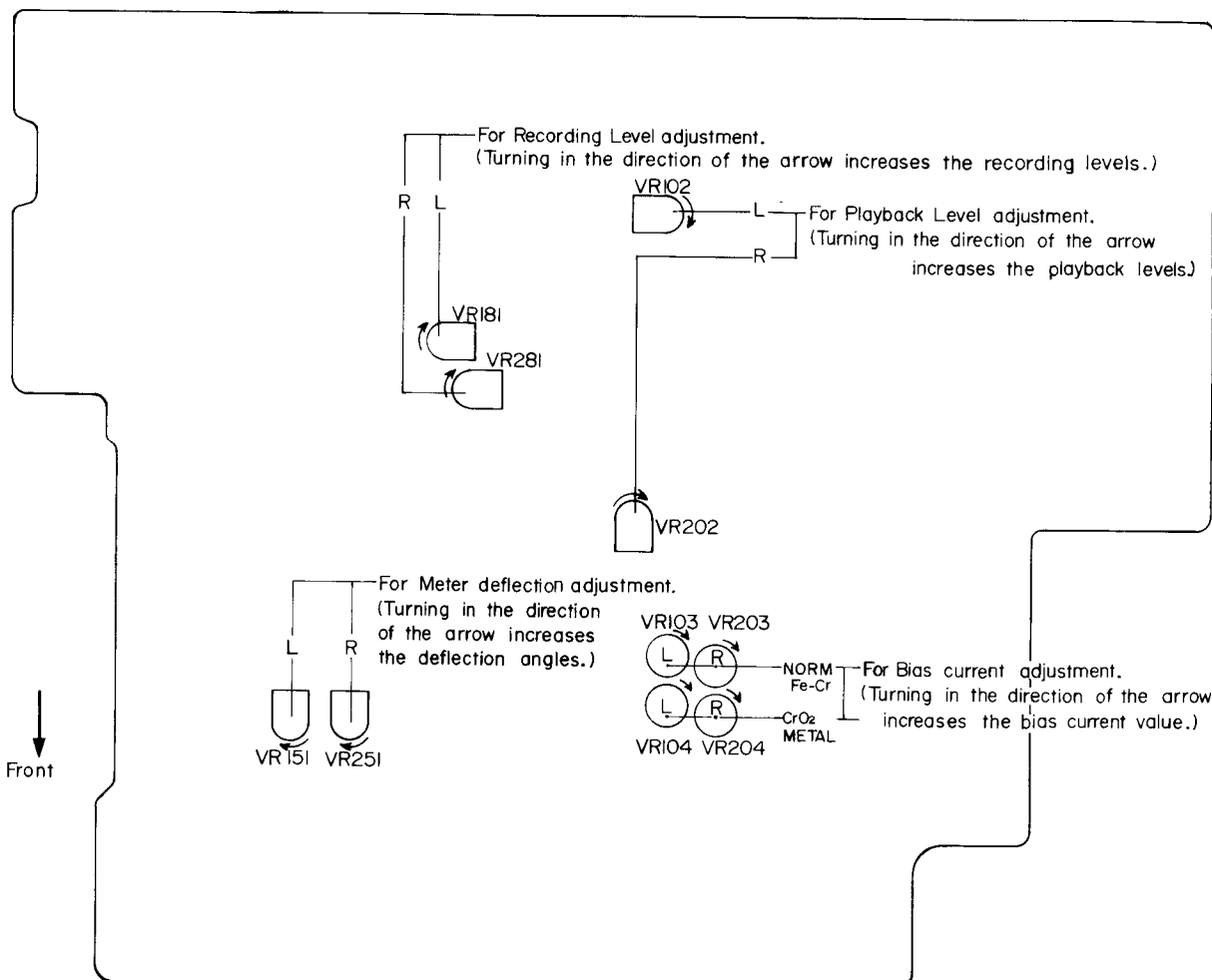

[V] Electrical circuit adjustment procedure

In all the steps (marked by an asterisk*) except the "Adjusting bias current", the adjustment is important. Be sure to perform it.

Adjustment should be performed in the sequential numerical order of the following:

Step	Item	Adjustment	Adjusting point	Standard value	Remarks
1*	Adjusting playback level	1. Playback the VTT-664 Reference tape (1 kHz) with the Tape select switch set to the NORMAL position. 2. Adjust VR 102 and VR 202 until the DIN OUT becomes 0.34V (about -7 dB).	VR102, 202	0.34 V (-7 dB)	1. This adjustment becomes necessary when a change in playback level results (for example, due to head replacement). 2. Perform this adjustment with the Dolby N.R. switch set to OFF.
2	Playback frequency response	Playback test tape VTT-675N (1 kHz, 10 kHz) for following adjustment. If the 10 kHz signal gain become nearly equal to the 1 kHz signal gain, cut off the wire tip 106. If the 10 kHz signal gain become low level, select 104 or 105 connector so that 10 kHz signal and 1 kHz signal gains become flat response.			

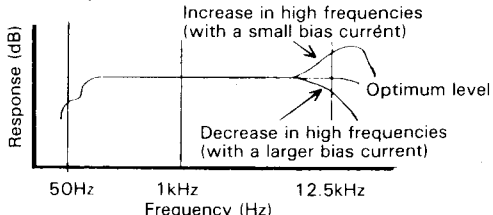
Step	Item	Adjustment	Adjusting point	Standard value	Remarks
3*	Adjusting VU meter sensitivity	<ol style="list-style-type: none"> 1. Set the cassette deck to its recording mode. 2. Apply a 1 kHz, approx. -10 dBs signal to the DIN IN terminals. 3. Adjust the recording level controls until the signal is available at -7 dBs at the DIN OUT terminals. 4. Adjust VR 151 and VR 251 until the VU meters deflect to 0. 	VR151 251	0 VU	Perform the adjustment when the parts are replaced.
4	Checking record/playback frequency response	Record 1 kHz, 100 Hz and 12.5 kHz signals at an input level of 0 VU to -20 dB. Play back the tape. Check to see that the 100 Hz and 12.5 kHz signal output deviations fall within the standard range, using the 1 kHz signal output as a reference. (It is basically desirable that the 1 kHz, 100 Hz and 12.5 kHz signal outputs are the same.)	For normal tape: VR103, 203 For CrO2 tape: VR104, 204	Reference frequency; 1 kHz 0±3 dB at 100 Hz 0±3 dB at 12.5 kHz	This checking should be performed for normal, chrome and metal tapes and for both right and left channels. Fe-Cr and METAL tapes use only to check.
5*	Checking recording bias current	Record 1kHz, 100Hz and 12.5kHz signals at an input level of 0VU to -20dB. Play back the tape. Adjust VR103 and VR203 (for a normal tape), VR104 and VR204 (for CrO2 tape), until the indicated deviation of the 12.5 kHz signal output from the 1kHz signal output becomes 0.		Output deviation; 0	<ol style="list-style-type: none"> 1. Bias current adjustment for a cassette deck should generally be performed referring to the record/playback frequency response. This is because the frequency response of a cassette deck depends more greatly upon the bias current than does that of an open reel deck. The current measuring method described below is an alternative one. 2. If the bias current is not properly adjusted the record and playback characteristics become as shown below. 
6	Adjusting recording level	<ol style="list-style-type: none"> 1. Apply a 1 kHz, approx. -10 dB signal to the DIN IN terminals. Adjust the recording level controls until the signal is available at -2 dBs at the DIN OUT. 2. After checking to see if the VU meter becomes to 0, record the signal applied to both left and right channels using a normal tape. 3. Play back the recorded part. Perform the recording signal adjustment with VR181 and VR281 so that the VU meter becomes to 0. 	VR142, 242	0 VU	The level difference between left and right channels for normal tape, chrome tape and metal tape should be less than 1 dB (1 VU). Perform the adjustment using a normal tape, level difference between recording and playback for CrO2 and metal tapes should be less than 1.5 dB, and that between left and right channels should also be less than 1 dB.
7	Checking record/playback signal distortion	<ol style="list-style-type: none"> 1. Record a 1 kHz, 0 VU -7 dBs signal to DIN IN terminals and perform recording with the VU meter becomes 0 VU. 2. Play back the recorded part. Check the output with a distortion meter to see if the value conforms to the standard value. 	Normal tape; less than 2%		Be sure to perform this adjustment following bias current and recording level adjustments.

Step	Item	Adjustment	Adjusting point	Standard value	Remarks
8	Checking signal to noise ratio recording/playback	<ol style="list-style-type: none"> Record a 1 kHz, 0 VU signal. Stop the input by disconnecting from the terminal to perform non-signal recording. Playback the recorded part. Measure the 0 VU recording output and the non-signal recording output for comparison using an electronic voltmeter. Check to see if the value conforms to the standard value. 		Normal tape; More than 42 dB Chrome tape; More than 42 dB Metal tape; More than 42 dB	Apply an output (-20.5 dBs) to the DIN IN terminals with the recording level controls set to maximum so that the VU meter becomes to 0.
9	Checking erasing coefficient	<ol style="list-style-type: none"> Apply a 1 kHz signal to the DIN IN terminals. Adjust the recording level controls until the VU meter becomes to 0. Erase a part of the recording. Measure the output difference between the erased part and non-erased part to compare with an electronic voltmeter. 		More than 65 dB	For the measuring, connect a band pass filter between the deck and the electronic voltmeter.

Integragt Circuit

[IC for Meter & HP Amp.]

UPC4557C

Top View

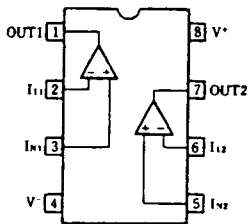

Equivalent circuit (1/2)

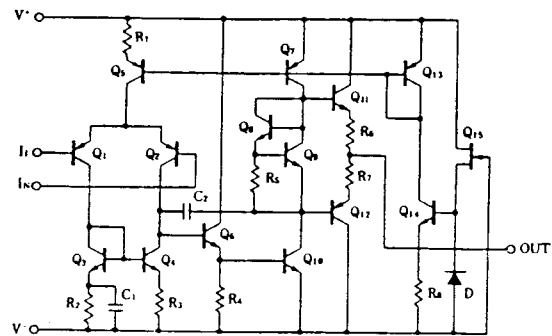

[IC FOR Dolby NR Circuit]

NE646BN

Top View

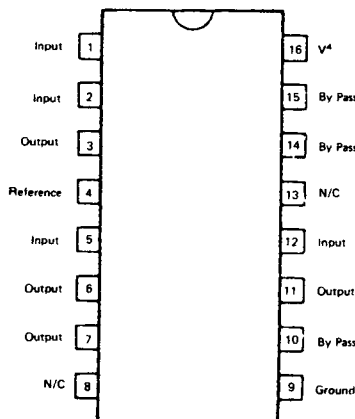

Block diagram

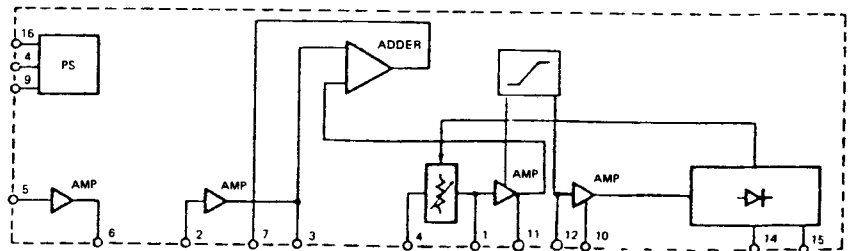

Block Diagram Recording system

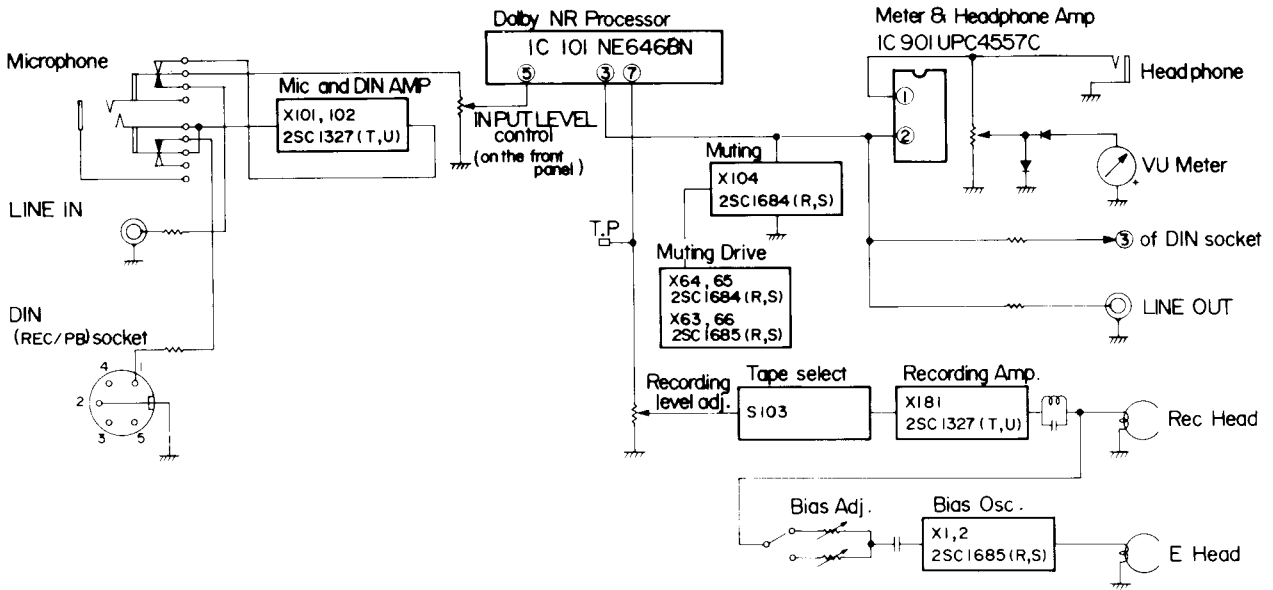

Playback system

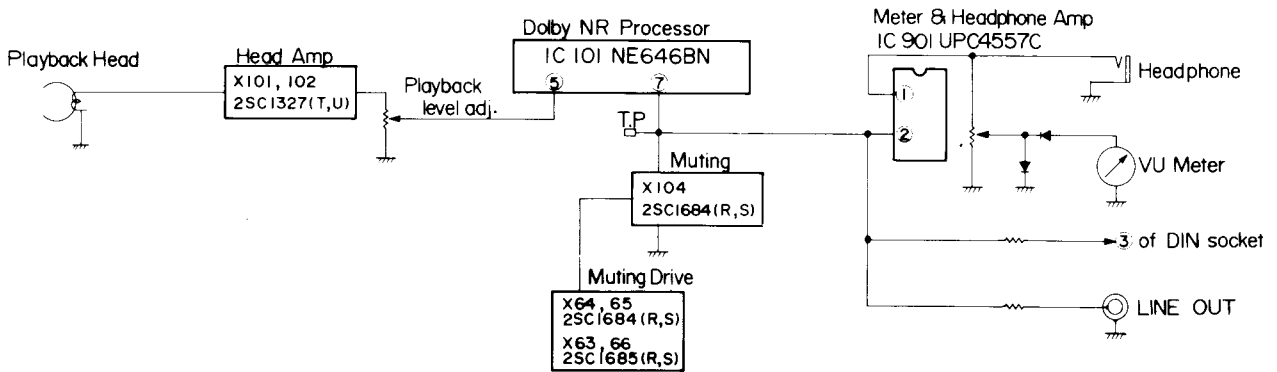

Enclosure Ass'y and Electrical Parts (Except P.W. Board Parts)

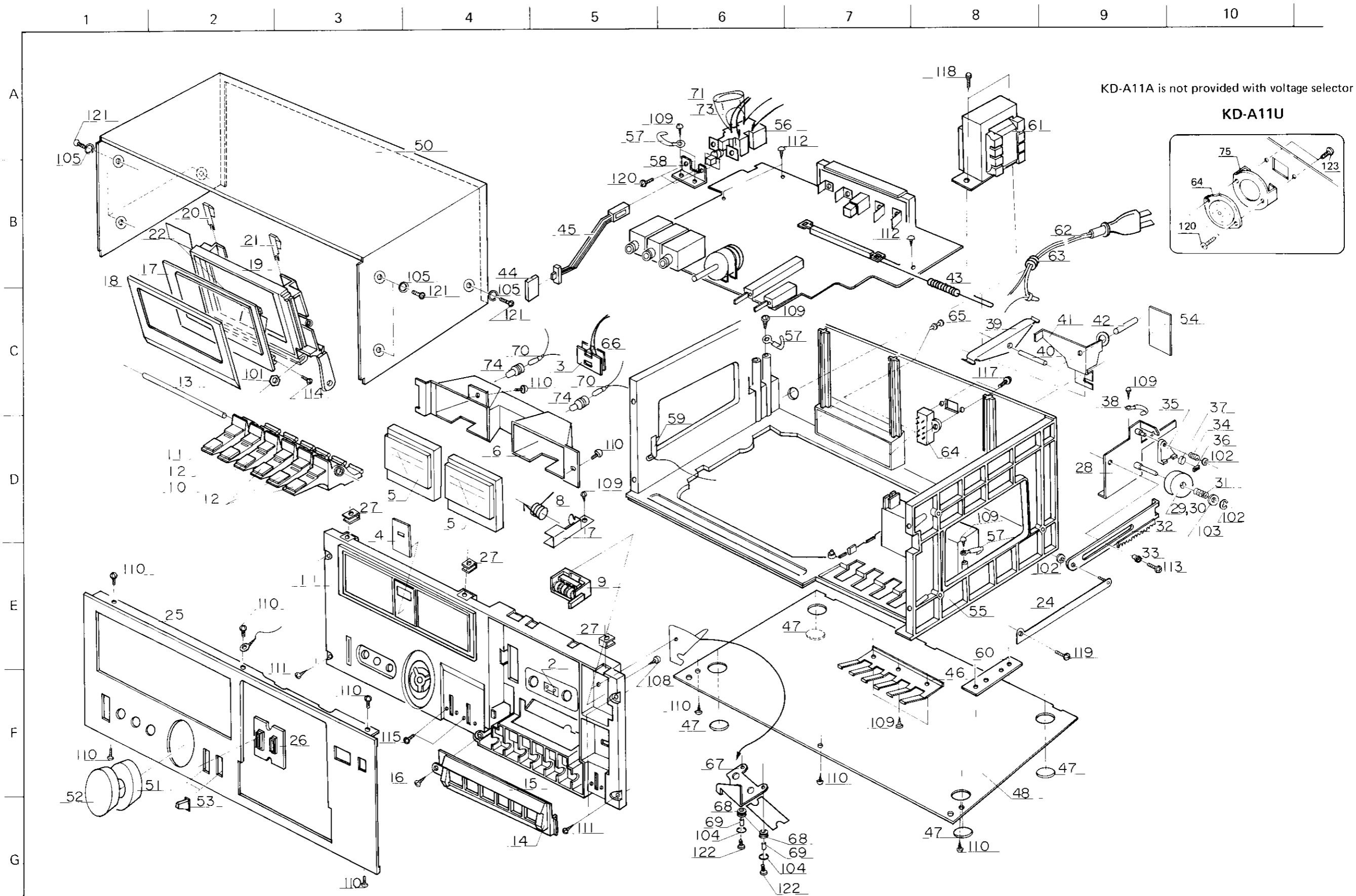

Main Amp. P.W. Board Parts

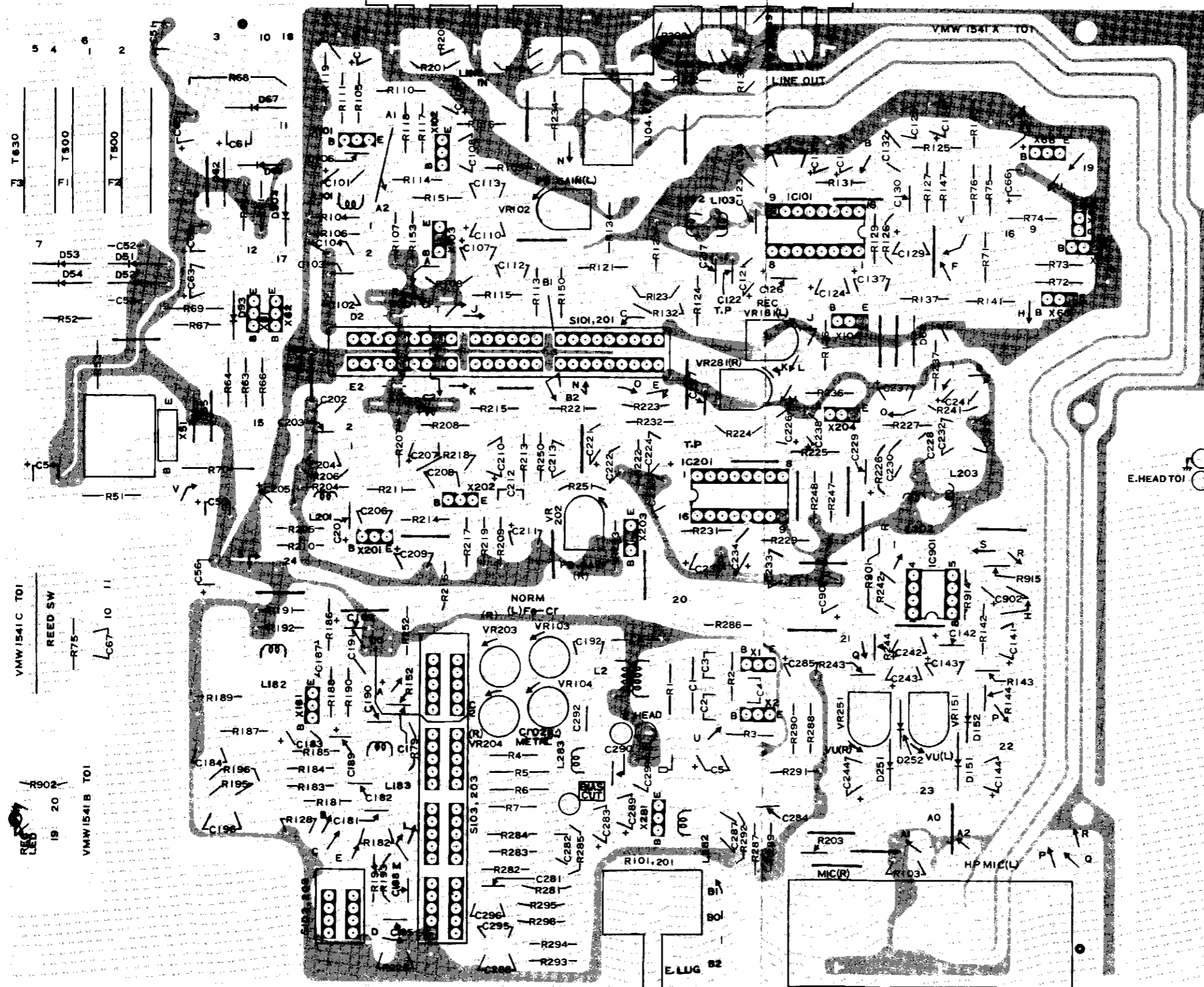

		1	2	3	4	5	6	7	8
IC101	E. Voltmeter	7.08	7.17	7.61	7.07	6.98	7.17	6.44	0
201	C. Tester	9.2	7.0	7.4	7	4.8	7.0	6.7	0
IC901	E. Voltmeter	10.61	10.66	10.63	0	10.63	10.64	10.61	21.3
	C. Tester	11	11	11	0	11	11	11	21.5

		9	10	11	12	13	14	15	16
IC101	E. Voltmeter	0	7.06	7.08	7.05	0	7.1	6.92	13.73
201	C. Tester	0	7.0	7.0	6.9	0	6.9	6.4	14

	E. Voltmeter			C. Tester		
	E	C	B	E	C	B
X101	1.12	2.67	0.58	1.0	2.7	0.5
X201	2.07	6.87	2.67	2.0	6.6	2.7
X102	0	0	0.7	0	0	0.7
X202	0	0	0.7	0	0	0.7
X103	0	0	0.7	0	0	0.7
X203	0	0	0.7	0	0	0.7
X1	1.24	20.1	-0.14	1.2	20.5	-0.2
X2	1.24	20.1	-0.14	1.2	20.5	-0.2
X181	0.85	7.54	1.42	0.82	6.9	1.1
281	0.85	7.54	1.42	0.82	6.9	1.1
X61	0.019	0.116	0.71	0.02	0.12	0.7
X62	0.019	24.8	0.116	0.02	25	0.12
X63	0	0.06	0.68	0	0.05	0.68
X64	0	0.68	0	0	0.68	0
X65	0	6.59	0	0	6.6	0
X66	0.01	0.32	0.85	0	0	0.84
X51	21.2	25.11	21.9	21.5	26	22

Wiring Connection

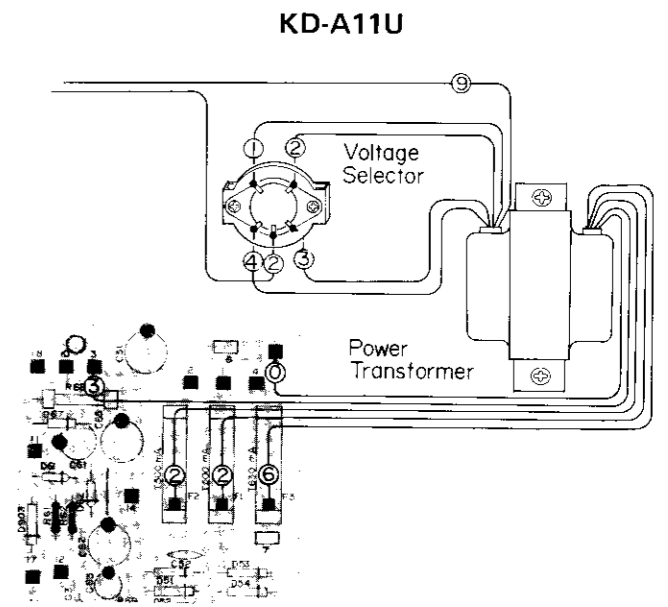
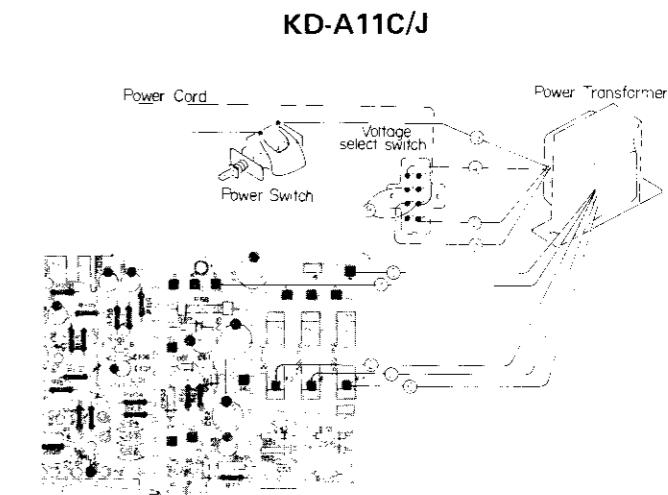
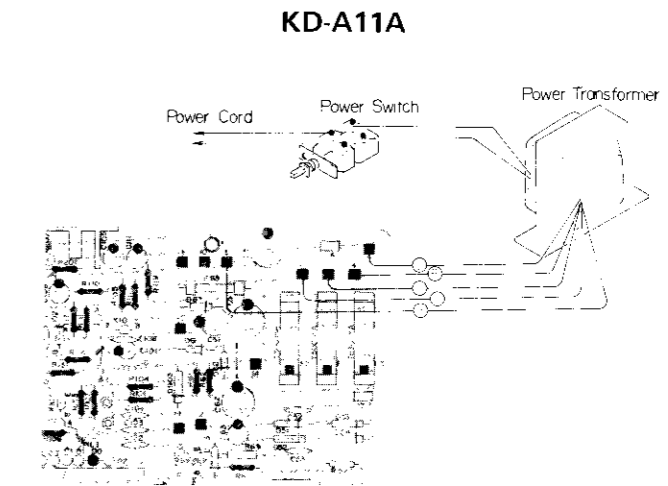
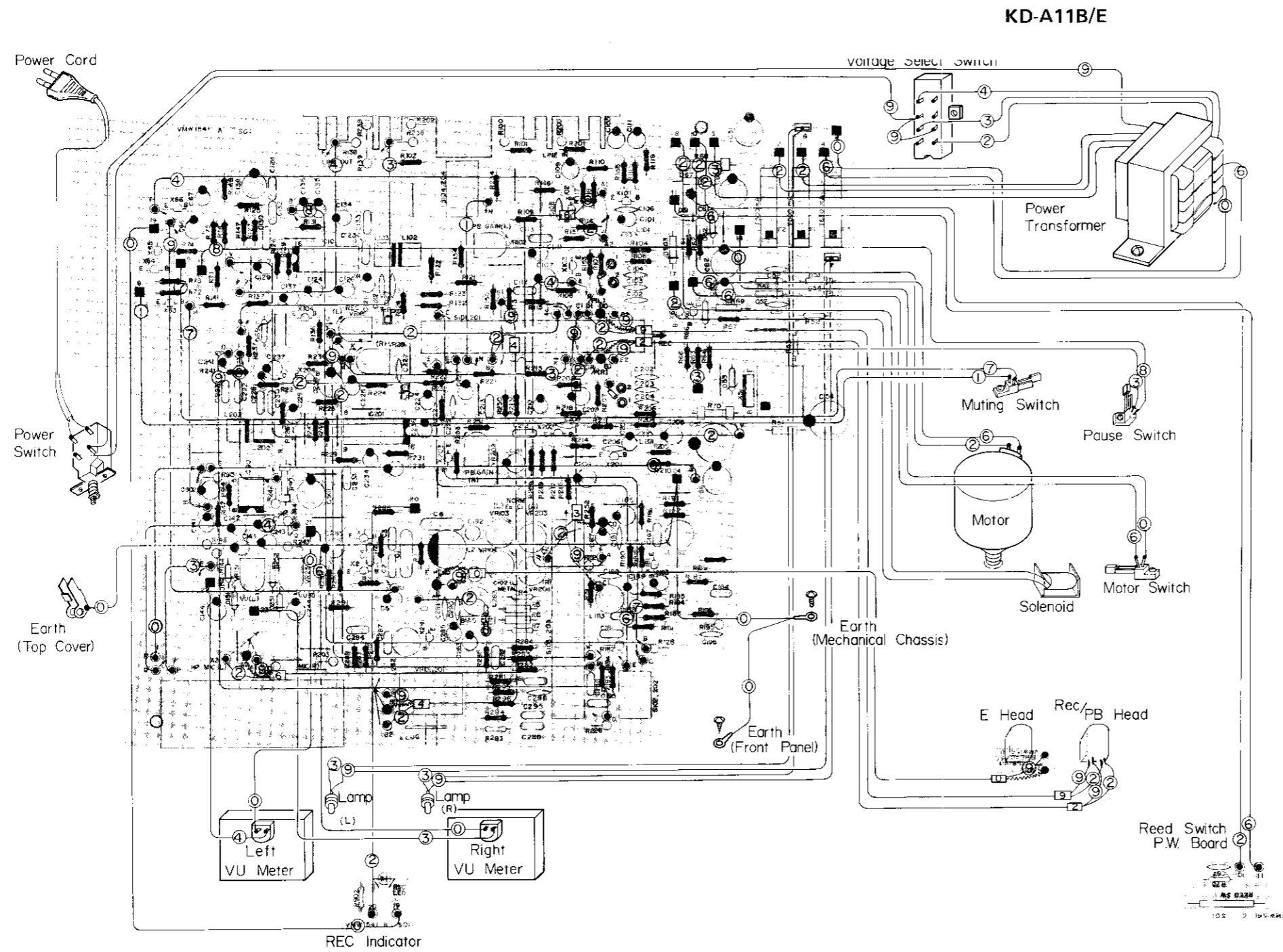

Color code are shown below

1	Brown	6	Blue
2	Red	7	Violet
3	Orange	8	Grey
4	Yellow	9	White
5	Green	0	Black

Standard Schematic Diagram of KD-A11

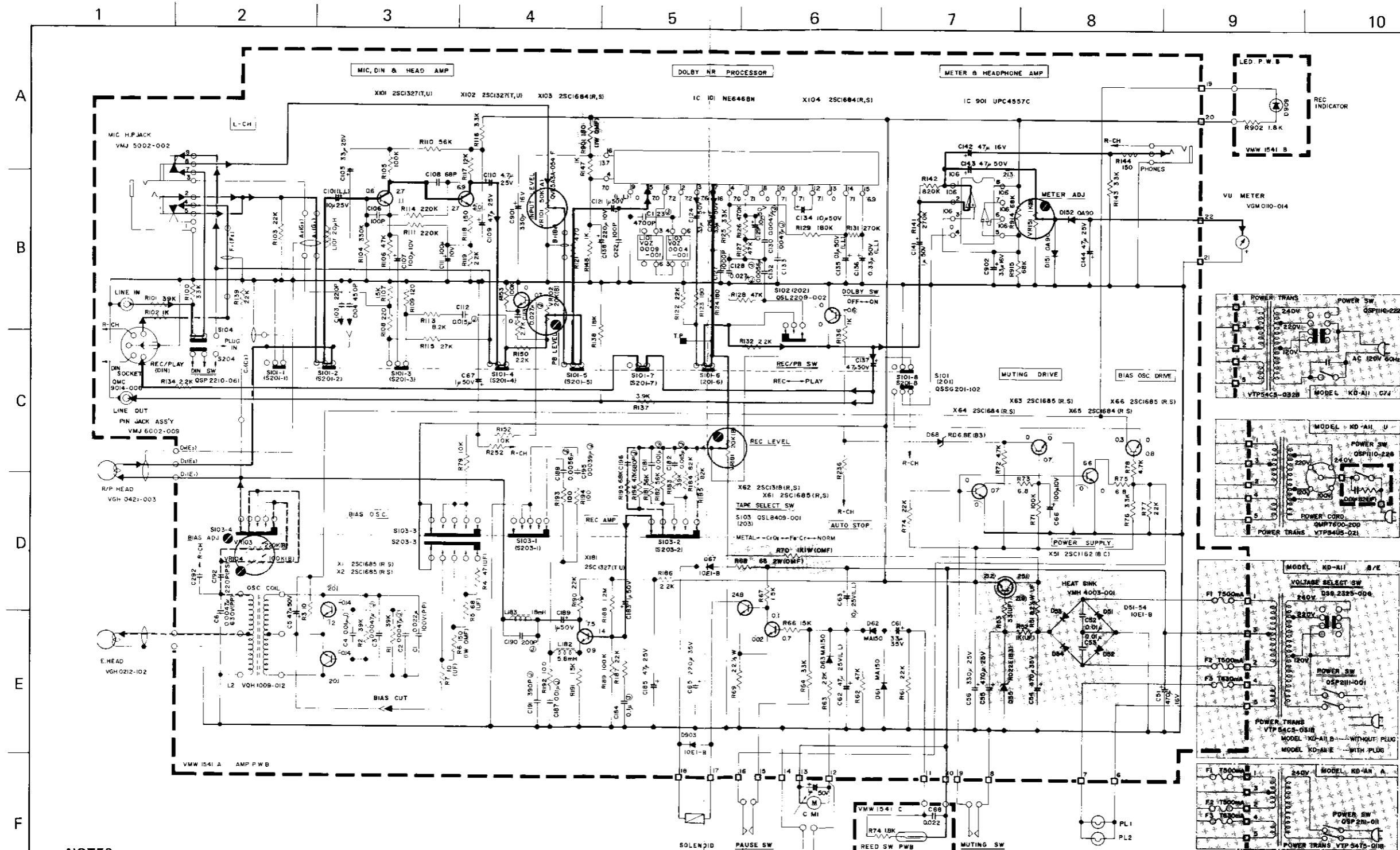

NOTES:

1. Unless otherwise specified, all resistors are 1/4W, ±5% carbon resistors. And all capacitors are 50V fixed ceramic capacitors or 50V Mylar capacitors.
2. UF - Unflamable carbon resistor
MF - Metal film resistor
OMF - Oxidized metal film resistor
Ta - Tantalum solid electrolytic capacitor
LL - +20% low leak current electrolytic capacitor
3. Blue line shows the signal at playback.
Red line shows the signal at recording and +B circuits.
4. * parts are safety assurance parts. When replacing those parts, make sure to use the specified one.

- | | |
|---------------------------------|---|
| PP - Polypropylene capacitor | PS - Polystyrene capacitor |
| MM - Metallized mylar capacitor | NP - Non-polarized electrolytic capacitor |

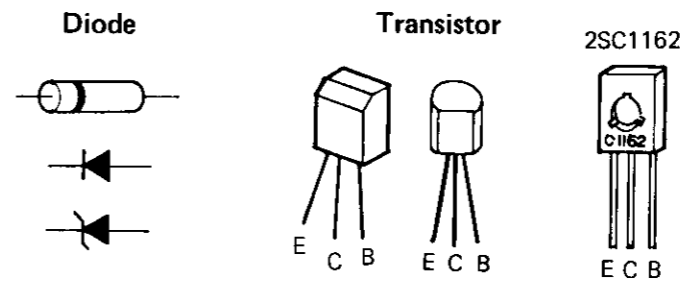

Mechanical Component Parts

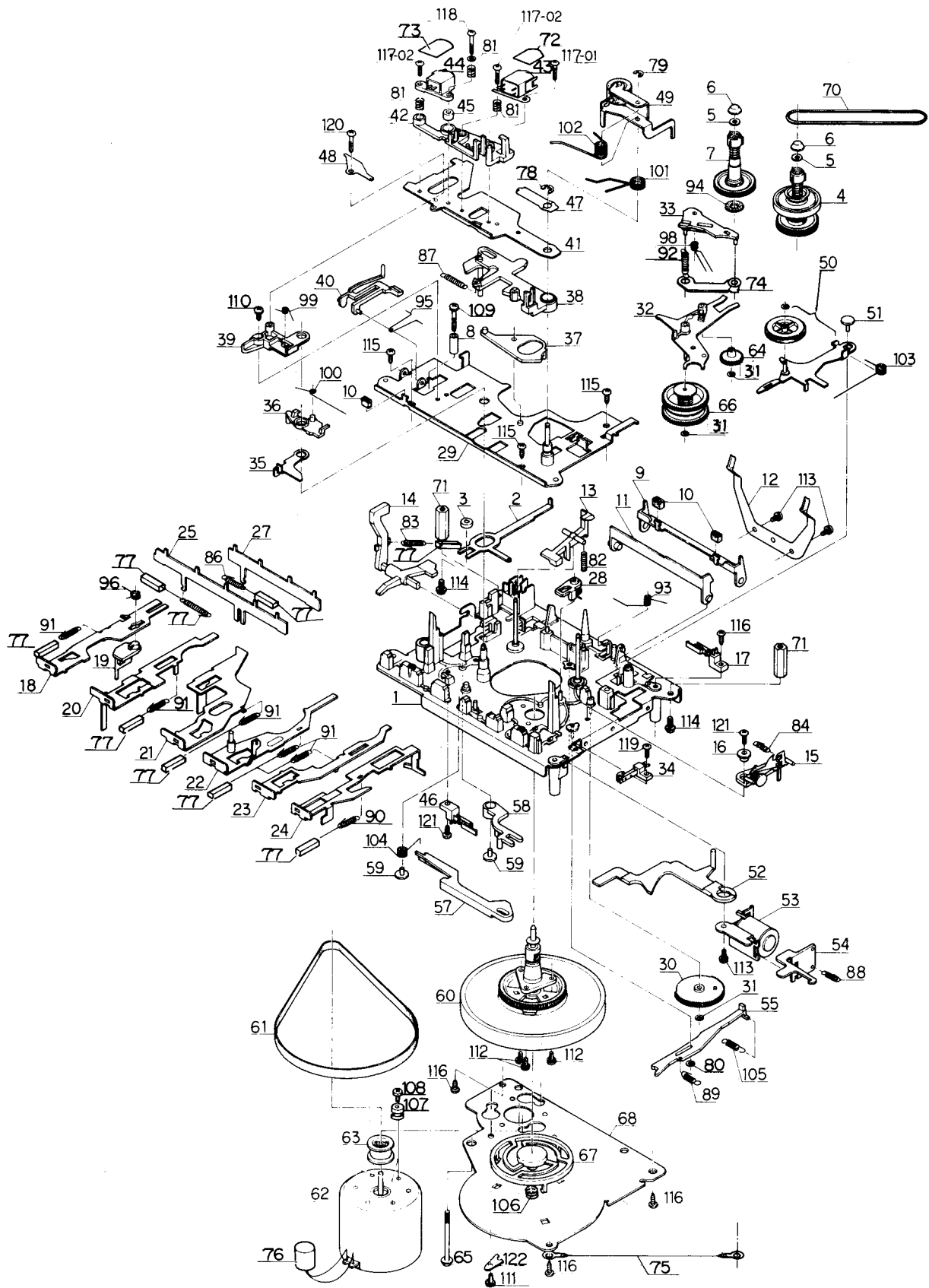

Mechanical Component Parts List

Ref. No.	Parts No.	Parts Name	Remarks	Q'ty
1	VKL1171-00A	Chassis Base Sub Ass'y	Brake	1
2	VKL4733-001	Slide Bar		1
3	VKS4213-001	Bushing		1
4	VKR4165-00A	Take up Disk Ass'y		1
5	VKR4170-001	Ring		2
6	VKS4131-001	Reel Stopper		2
7	VKR4172-00A	Supply Disk Ass'y		1
8	VKH3000-036	Collar		1
9	VKS4214-001	Brake Lever		1
10	VKZ4137-001	Brake Rubber		3
11	VKS4215-001	Switch Lever		1
12	VKY4190-001	Pack Spring		1
13	VKS4217-001	Rec Safety		1
14	VKS4218-001	Lock Arm		1
15	VKS4243-00A	Pause Bracket Ass'y		1
16	VKH3001-034	Flange Collar	for Motor	1
17	VSH1105-002	Switch		1
18	VKL4735-001	Stop Bar		1
19	VKS4220-001	Select Cam		1
20	VKL4736-001	Rew Bar		1
21	VKL4737-002	Rec Bar		1
22	VKL4790-00A	Play Bar Ass'y		1
23	VKL4740-001	FF Bar		1
24	VKL4741-001	Pause Bar		1
25	VKL4758-001	Cam		1
27	VKL4789-001	Sub Cam		1
28	VKS4244-00A	Spring Holder Ass'y		1
29	VKL3236-00A	Button Cover Ass'y		1
30	VKR4179-001	Auto Cam		1
31	VKZ4004-001	Special Washer		3
32	VKL3245-00A	Gear Base Ass'y	Pause	1
33	VKS4222-001	Stopper Cover		1
34	VSH1102-001	Switch		1
35	VKL4745-002	Lock Plate		1
36	VKF4105-001	Rew Lever		1
37	VKS4224-001	FF Lever		1
38	VKS3119-001	Arm		1
39	VKS4225-00A	Arm Holder Ass'y		1
40	VKS4239-001	Door Safety		1
41	VKL3240-001	Head Base		1
42	VKS3120-001	Head Mount Base	for Mut	1
43	VGH0421-003	R/P Head		1
44	VGH0212-102	E Head		1
45	VKH3000-035	Collar		1
46	VSH1105-002	Switch		1
47	VKY4183-001	Spring Plate		1
48	VKY4184-001	Pressure Plate		1
49	VKP4109-00A	Pinch Roller Arm Ass'y		1
50	VKL4748-00A	Take up Idler Arm Ass'y		1
51	VKS4233-001	Lock Bush		1
52	VKS4228-001	Select Arm		1
53	VGP0601-003	DC Solenoid Ass'y		1
54	VKL4861-001	Trigger		1
55	*VKS4246-002	Kick Lever		1

Ref. No.	Parts No.	Parts Name	Remarks	Q'ty
57	VKS4230-001	Select Bar		1
58	VKS4231-001	Switch Arm		1
59	VKS4233-001	Lock Bush		2
60	VKF3112-00A	Flywheel Unit Ass'y		1
61	VKB3001-007	Belt		1
62	MMI-6B2HD	DC Motor		1
63	VKS4139-002	Motor Pulley		1
64	VKR4173-001	Rewind Gear		1
65	VKZ4009-001	Special Screw		1
66	VKR4174-00A	F.F Gear Ass'y		1
67	VKS4232-001	Flywheel Holder		1
68	VKL4747-001	F. M. Bracket		1
70	VKB3000-012	Belt		1
71	VKH3011-003	Stud		1
72	VND4012-002	Head Plate	Meta Parm	1
73	THS000489-02	Head Label	2 Gap	1
74	VKS4248-001	Synchro Arm		1
75	VMZ0008-00B	Wire Ass'y		1
76	QET41HR-105N	E. Capacitor		1
77	VKZ4139-001	Silencer		9
78	REE3000	"E" Ring		1
79	REE2000	"		1
80	REE1500	"		1
81	VKW3001-036	Spring	Compression for REC/PB, E Head	1
82	VKW3001-050	"	Compression for REC safety	1
83	VKW3002-047	"	Tension for Lock arm	1
84	VKW3002-048	"	Tension for Pause Bracket	1
85	VKW3002-049	"	Tension for Main cam	1
86	VKW3002-050	"	Tension for Sub cam	1
87	VKW3002-051	"	Tension for Arm	1
88	VKW3002-057	"	Tension for DC solenoid	1
89	VKW3002-004	"	Tension for Kick Lever	1
90	VKW3004-003	"	Tension for Pause bar	1
91	VKW3004-002	"	Tension Play Bar x 1 Select Cam x 1 Rew Bar x 1 Recording Bar x 1 FF Bar x 1	5
92	VKW3002-053	"	Tension Stop Cover	1
93	VKW4206-001	"	Torsion Switch Bar	1
94	VKZ4003-003	Clutch felt	Back Tension	1
95	VKW4229-001	Spring	Torsion Door Safety	1
96	VKW4209-001	"	Torsion Select Cam	1

Ref. No.	Parts No.	Parts Name	Remarks	Q'ty
97	VKW4210-001	Spring	Torsion FF bar	1
98	VKW4211-003	"	Torsion Stop Cover	1
99	VKW4212-001	"	Torsion Lock Plate	1
100	VKW4213-002	"	Torsion Rew Lever	1
101	VKW4214-003	"	Over stroke Pressure Plate	1
102	VKW4215-001	"	Torsion Pinch Roller	1
103	VKW4216-002	"	Torsion Idler Arm	1
104	VKW4217-001	"	Torsion Select Bar	1
105	VKW3005-001	"	Tension Kick Lever	1
106	VKW3001-048	"	Flywheel	1
107	VKZ4130-001	Cushion Rubber	for Motor	3
108	VKZ4109-001	Motor Screw	for Motor	3
109	SPSP2614Z	Screw	Pinch Roller Stud	1
110	LPSP2605Z	"	Arm Holder	1
111	LPSP2604Z	"	Rubber Stopper	1
112	LPSP2605Z	"	Flywheel Ass'y	3
113	SPSP2604Z	"	DC Solenoid x 1 Pack spring x 2	3
114	LPSP3006ZS	"	Stud	2
115	SBSB2606Z	"	Button Cover Ass'y	3
116	SBSB2608Z	"	Flywheel Bracket x 3 Motor Switch x 1	4
117-01	SPSX2008Z	"	Erase Head	1
117-02	SPSX2010Z	"	REC/PB Head	2
118	SPSX2014Z	"	Erase Head	1
119	SPSP2606Z	"	Pause Switch	1
120	SPSP2010Z	"	Pressure Plate	1
121	SPSP2604Z	"	Pause Bracket Ass'y x 1 Muting Switch x 1	2
122	TFB345469-01	Rubber Stopper		1

Enclosure Assembly and Electrical Parts list (Except P.W. Board Parts)

△ parts are safety assurance parts. When replacing those parts, make sure to use the specified one.

Ref. No.	Parts No.	Parts Name	Remarks	Q'ty
(1,2,4)	ZCKDA11Y-CBF-1	Front Panel Sub Ass'y		1 set
1	VJC1108-001	Front Panel		1
2	*VJD4162-002	Reel Disk Plate		1
3	*VJD4410-001	Escutcheon	for Rec LED	1
4	*VJD4369-002	Indicator Plate		1
5	VGM0110-014	Level Meter		2
6	VKS2109-001	Lamp Cover		1
7	VKL4697-001	Spring Bracket		1
8	VKW4199-001	Spring		1
9	VKC5135-001T	Counter		1
10	*VXP3052-004	Mecha Button	Rec	1
11	*VXP3052-005	"	Stop	1
12	*VXP3052-006	"		4
13	VKH4268-001	Shaft	for Mecha Button	1
14	VJD3221-001	Button Escutcheon		1
15	*VJD4370-002	Control Plate		1
16	VKZ4007-001	Special Screw		1
(17~18)	ZCKDA11Y-CCA	Cassette Door Sub Ass'y		1 set
17	VJT3052-001	Cassette Lid		1
18	VJT3053-001	Lid Plate		1
19	VJT2041-001	Cassette Holder		1
20	VKY4178-001	Cassette Spring		1
21	VKY4178-002	"		1
22	*VJD4378-003	Mark	Meta Parm	1
23	VYSR102-014	Spacer		1
24	VKL4698-00A	Arm Ass'y	Cassette Holder	1
(25,26)	ZCKDA11Y-CBF-2	Front Plate Ass'y		1 set
25	*VJC1107-003	Front Plate		1
26	*VJD3222-003	Lever Escutcheon		1
27	TFB313563-02	Plate Nut		3
28	VKL4169-00A	Gear Frame Ass'y		1 set
29	VKS4236-001	Spur Gear		1
30	VKS4109-004	Brake Drum		1
31	VKW3001-006	Spring		1
32	VKS3102-001	Rack Plate		1
33	VKH4123-001	Collar		1
34	VKW4106-001	Torsion Spring		1
35	VKS4110-002	Brake Arm		1
36	VKL4271-001	Rubber Retainer		1
37	VKZ4111-001	Rubber Tire		1
38	VKZ4001-011	Wire Holder		1
39	VKL4163-001	Rec. Arm (1)		1
40	VKH4121-001	Shaft		1
41	VKL4164-001	Rec. Arm (2)		1
42	VKH4121-002	Shaft		1
43	VKW4244-001	Rec. Spring		1
44	VXP4066-001	Push Button	Power	1
45	VKS4209-001	Remote Bar	Power	1
46	VKY4111-002	Button Spring	Amp chassis	1
47	VJF4003-001	Foot	Amp chassis	4
48	VKL2123-001	Bottom Cover		1
49	VKL4291-002	Shield Plate		1
50	VJC1109-001	Top Cover		1
51	VXL4124-00A	Knob Ass'y		1
52	VXL4125-00A	"		1
53	VXQ4030-001	Lever Knob		2
54	VYN2068-002LA	Name Plate	KD-A11A	1
	VYN2068-001LA	"	KD-A11B	1
	" -003LA	"	KD-A11C	1
	" -004LA	"	KD-A11E	1
	" -007LA	"	KD-A11E(SP)	1
	" -005LA	"	KD-A11J	1
	" -006LA	"	KD-A11U	1
55	VYH1116-001	Amp chassis	KD-A11A/B/U	1
	VYH1116-002	"	KD-A11C/J/E	1

Ref. No.	Parts No.	Parts Name	Remarks	Q'ty
56	△ QSP2111-011	Power Switch	KD-A11A/E	1
	△ " -011BS	"	KD-A11B	1
	△ QSP1110-222	"	KD-A11C/J	1
	△ QSP1110-226	"	KD-A11U	1
57	VKZ4001-010	Wire Holder		4
58	VKL4194-001	SW Bracket		1
59	VKY4181-001	Earth Lug	for Top Cover	1
60	VKL4167-001	Transformer Bracket		1
	△ VTP54T5-011B	Power Transformer	KD-A11A	1
	VTP54U5-021	"	KDA-11U	1
61	△ VTP54C5-031BBS	"	KD-A11B	1
	△ VTP54C5-031B	"	KD-A11C/E/J	1
62	△ QMP2560-200	Power Cord	KD-A11A	1
	△ QMP1200-200	"	KD-A11C/J	1
	△ QMP3900-200	"	KD-A11E	1
	△ QMP9017-008BS	"	KD-A11B	1
63	△ QHS3876-252	Strain Relief	KD-A11A/E	1
	△ QHS3876-252BS	"	KD-A11B	1
	△ QHS3056-252	"	KD-A11C/J	1
64	△ QSS2325-011	Slide Switch	for Voltage Selector KD-A11C/E/J	1
	△ QSS2325-011BS	Slide Switch	for Voltage Selector KD-A11B	1
	△ QSR0084-001	Voltage Select Switch	KD-A11U	1
65	E48729-003	Plastic Rivet	for PIN jack	2
66	SLP-155B-01V	LED	REC	1
67	VKL4712-001	Switch Bracket	for Reed SW P.W.B	1
68	53492-002	Rubber Bushing		2
69	T30302-063	Collar		2
70	T47861-003N	Lamp		2
71	△ QFH72BM-223	M.M Capacitor	KD-A22J 0.022μF	1
	△ QFZ9008-223	"	KD-A22C 0.022μF	1
	QCZ9015-103	Capacitor	KD-A11U	1
72	△ TAW000504-01	Wire Connector	KD-A22C/J	2
73	△ T47047-001	Capacitor Boot	KD-A22C/J	1
74	VYH4315-002	Lamp Holder		2
75	VKL4275-001	Bracket	Voltage Select SW KD-A11U	1
101	NNS2600ZS	Nut	for Cassette Holder	1
102	REE2000	E ring	for Gear Frame Ass'y x 2 Amp Ass'y ~ Gear Dump x 1	3 1
103	WNS2600Z	Washer	for Brake Drum	1
104	WNS3000N	"	for Reed SW P.W.B	2
105	Q03093-502	"	for Top Cover	6
106	" -524	"	for Spur Gear	1
108	SBSB2608Z	Tapping Screw	for Counter	1
109	SBSB3008Z	"	for Spring Bracket x 1 Gear Dump x 1 Bottom Spring x 3 Switch Bracket x 2 Wire Holder x 2	9
110	SBSB3010Z	"	for Lamp Cover x 2 Front Plate x 5 Bottom Cover x 3	
111	SBSB3012Z	"	for Front Panel	4
112	SBSB3012V	"	for Main P.W.B	3
113	SDSP2608Z	Screw	for Brake Arm	1
114	SDSP2610RS	"	for Cassette Holder	1
115	SDSP3006VS	"	for Tape Selector	1
116	SPSP3006ZS	"	for Reed Swtich	1
117	SDSP3008RS	"	for Voltage Selector KD-A11B/C/E/J	2
118	DPSP4012ZS	"	for Power Transformer	2
119	LDSP2604R	Ass'y Screw	Arm Ass'y ~ cassette holder	1
120	LPSP3006ZS	Screw	for Power Switch x 2 for Bracket (KD-A11U) x 2	4
121	SDSB4010R	"	for Top Cover	6
122	SPSP2608Z	"	for Reed SW P.W.B	2
123	SDSP3006RS	Screw	for Voltage Selector KD-A11U	2

Main Amp. P.W. Board Parts List

△ parts are safety assurance parts.

When replacing those parts, make sure to use the specified one.

Ref. No.	Parts No.	Parts Name	Remarks	Q'ty
R100,200	△VMW1541-002A	P.W.B		1
R101,201,1,2	QRD143J-333S	C. Resistor	33kΩ 1/4W	2
R102,202,136,236	QRD141J-393SY	"	39kΩ "	4
147,247	QRD143J-102S	"	1kΩ "	6
R103,203,122,222	QRD143J-223S	"	22kΩ "	10
187,287,190,290				
61,74				
R104,204,	QRD141J-334SY	"	330kΩ "	2
R105,205,153,253	" -104SY	"	100kΩ "	7
189,289,71				
R106,206	" -472SY	"	4.7kΩ "	2
R107,207,191,291	" -152SY	"	1.5kΩ "	4
R108,208	" -221SY	"	220Ω "	2
R109,209	QRD141J-121SY	C. Resistor	120Ω "	2
R118,218	" -151SY	"	150Ω "	2
R110,210	" -563SY	"	56kΩ "	2
R111,211,114,214	" -224SY	"	220kΩ "	4
R113,213	" -822SY	"	8.2kΩ "	2
R137,237	" -392SY	"	3.9kΩ "	2
R115,215	" -273SY	"	27kΩ "	2
R116,216,125,225	" -332SY	"	3.3kΩ "	6
143,243				
R117,217	" -123SY	"	12kΩ "	2
R119,219,132,232	" -222SY	"	2.2kΩ "	10
150,250,134,234				
186,286				
R121,221	" -471SY	"	470Ω "	2
R123,223,124,224	" -181SY	"	180Ω "	4
R126,226	" -474SY	"	470kΩ "	2
R127,227,128,228	" -473SY	"	47kΩ "	4
R129,229	QRD141J-184SY	C. Resistor	180kΩ "	2
R131,231	" -274SY	"	270kΩ "	2
R139,239	QRD143J-223S	"	22kΩ "	2
R141,241	QRD141J-274SY	"	270kΩ "	2
R142,242	QRD143J-824S	"	820Ω "	2
R144,244	" -151S	"	150Ω "	2
R138,238	QRD141J-183SY	"	18kΩ "	2
R151,251	" -272SY	"	2.7kΩ "	2
R152,252	QRD143J-103S	"	10kΩ "	2
R181,281,182,282	QRD141J-563SY	"	56kΩ "	4
R183,283	" -393SY	"	39kΩ "	2
R184,284	" -823SY	"	82kΩ "	2
R185,285	" -823SY	"	82kΩ "	2
R188,288	" -125SY	"	1.5MΩ "	2
R192,292,193,293	" -101SY	"	100Ω "	2
194,294				
R195,295	" -683SY	"	68kΩ "	2
R196,296	" -473SY	"	47kΩ "	2
R3	QRD147J-100S	"	10Ω 1/4W	1
R4	△QRD149J-470S	Unflammable Resistor	47Ω "	1
R5	△QRD149J-680S	"	68Ω "	1
R6	△QRG019J-151S	"	150Ω 1W	1
R7	△QRD149J-100S	"	10Ω 1/4W	1
R51	△QRD126K-8R2	"	8.2Ω 1/2W	1
R52	△QRD149J-102S	"	1kΩ 1/4W	1
R53	△QRD149J-330S	"	33Ω "	1
R62	QRD141J-473SY	C. Resistor	47kΩ "	1
R63	" -222SY	"	2.2kΩ "	1
R64	QRD147J-333S	"	33kΩ "	1
R66	QRD147J-153S	"	15kΩ "	1
R67	" -152SY	"	1.5kΩ "	1
R68	△QRG029J-680	O.M.F. Resistor	68Ω 2W	1
R69	△QRD121K-2R2	C. Resistor	2.2Ω 1/2W	1

Ref. No.	Parts No.	Parts Name	Remarks	Q'ty
R70	△QRG019J-102	O.M.F. Resistor	1kΩ 1W	1
R72	QRD141J-472SY	C. Resistor	4.7kΩ 1/4W	1
R73,75	QRD147J-6R8S	"	6.8 Ω "	2
R76	" -332SY	"	3.3kΩ "	1
R77	" -222SY	"	2.2kΩ "	1
R78	" -472SY	"	4.7kΩ "	1
R79	" -103SY	"	10kΩ "	1
R901	△QRG019G-181	O.M.F. Resistor	180 Ω 1W	1
R902	QRD147J-182S	C. Resistor	1.8kΩ 1/4W	1
R914,915	QRD143J-683S	"	68kΩ "	2
	QWY123-019	Bus Wire	P=10mm	21
C101,201	QEB41EM-106M	E. Capacitor (Low Leak)	10μF 25V	2
C104,204	QCS11HJ-451	C. Capacitor	450pF 50V	2
C103,203	" -221	"	220pF "	2
C105,205	QET41ER-336W	E. Capacitor	33μF 25V	2
C106,206,122,222	QCS11HK-101	C. Capacitor	10pF 50V	4
C107,207,111,211 66	QET41AR-107N	E. Capacitor	100μF 10V	5
C108,208	QCS11HK-680	C. Capacitor	68pF 50V	2
C109,209,142,242 144,244	QET41ER-476F	E. Capacitor	47μF 25V	6
C110,210,143,243	QFT41HR-475N	"	4.7μF 50V	4
C112,212	QFM41HJ-153	Mylar Capacitor	0.015μF 50V	2
C113,213	QFM41HJ-273	"	0.027μF "	2
C121,221	QEB41HM-105M	E. Capacitor (Low Leak)	1μF "	2
C123,223,130,230 2,3	QFM41HJ-472	Mylar Capacitor	0.0047μF "	6
C124,224,126,226	QET41HR-335N	E. Capacitor	3.3μF "	4
C127,227	QCF11HP-102	C. Capacitor	0.001μF "	2
C128,228	QFM41HJ-273	Mylar Capacitor	0.027μF "	2
C129,229,134,234	QET41HR-106N	E. Capacitor	10μF "	4
C132,232	QFM41HJ-562	Mylar Capacitor	0.0056μF "	2
C133,233	QFM41HJ-473	"	0.047μF "	1
C135,235	QEB41HM-104M	E. Capacitor (Low Leak)	0.1μF "	2
C136,236	" -334M	"	0.33μF "	2
C137,237	QET41HR-475N	E. Capacitor	4.7μF "	2
C138,238	QET41AR-227N	"	220μF 10V	2
C141,241,183,283 189,289	QET41HR-105N	"	1μF 50V	6
C181,281	QFM41HJ-102	M. Capacitor	0.001μF "	1
C182,282	QFM41HJ-152	Mylar Capacitor	0.0015μF "	2
C184,284	QFM41HJ-104	"	0.1μF "	2
C185,285	QET41ER-476N	E. Capacitor	47μF 25V	2
C187,287	QFM41HJ-103	Mylar Capacitor	0.01μF 50V	2
C188,288	QFM41HJ-562	"	0.0056μF "	2
C190,290	QCS12HJ-201	C. Capacitor	200pF "	2
C191,291	QCS11HJ-391	"	390pF "	2
C192,292	QFS32BK-221	"	220pF "	2
C195,295	QFM41HJ-392	Mylar Capacitor	0.0039μF 50V	2
C196,296	QCS11HJ-681	C. Capacitor	680pF "	2
C1	QFP82AJ-223	Polypropylene capacitor	0.022μF "	1
C4	QFM41HJ-103	Mylar Capacitor	0.01μF 50V	1
C5	QET41HR-475N	E. Capacitor	4.7μF "	1
C6	QFP82XJ-472	Polypropylene Capacitor	0.0047μF "	1
C51	△QET41CR-477N	E. Capacitor	470μF 16V	1
C52,53	△QCF12HP-103	C. Capacitor	0.01 μF 50V	2
C54	△QET41VR-477N	E. Capacitor	470μF 35V	1
C55	QET41ER-477N	"	470μF 25V	1
C56	△QET41ER-337N	"	330μF 25V	1
C61	QET41VR-336N	E. Capacitor	33μF 35V	1
C62	QEB41EM-476N	E. Capacitor (Low Leak)	47μF 25V	1
C63	" -106M	"	10μF "	1
C65	△QET41VR-227N	E. Capacitor	220μF 35V	1
C67	QET41HR-105N	"	1μF 50V	1
C901	QET41CR-337N	"	330μF 16V	1
C902	QET41CR-336N	"	33μF "	1

Ref. No.	Parts No.	Parts Name	Remarks	Q'ty
VR101,201	QVE5A3A-054F	V. Resistor	Input level 50k Ω	2
VR102,202	TAZ336499-03	Volume Lug	for Input level	1
181,281	QVP8AQB-024	V. Resistor	P.B and REC 20k Ω	4
VR103,203	QVP4A0B-224	"	Bias 22k Ω	2
VR104,204	QVP4A0B-104	"	Bias 10k Ω	2
VR151,251	QVP8A0B-013	"	VU meter 1k Ω	2
L101,201	TAC000493-01	Indicator		2
L102,202	VQZ0009-001	Dolby NR Filter	81k	2
L103,203	VQZ0004-001	"	19k	2
L183,283	VQP0001-183	Indicator		2
L182,282	" -562	"		2
L2	VQH1009-012	OSC Coil		1
	VMJ5002-002	Mic & HP. Jack Ass'y		1
	VMJ6002-009	PIN jack Ass'y		1
	QMC9014-006	PIN Socket		1
S104,204	QSP2210-061	Push Switch	for DIN	1
S101,201	QSSG201-102	Slide Switch	for R/P	1
S102,202	QSL2209-002	Lever Switch	for Dolby NR	1
S103,203	OSL8409-001	"	for Tape Selector	1
	VMZ0005-001	Post Pin		5
	E43727-002	Wrapping Tab		25
	E40130-001	Tab	for Lamp	2
F1,F2	△TAZ000331-02	Fuse Holder		6
	△QMF51A2-R50	Fuse	KD-A11A/E	2
	△QMF51A2-R50BS	Fuse	KD-A11B	2
F3	△QFM51A2-R50	"	KD-A11A/E	1
	△QFM51A2-R63BS	"	KD-A11B	1
	VMH4003-001	Heat Sink	for X51	1
	SDSP3006ZS	Screw	Heat Sink ~ P.W.B	1
	LPSP3008ZS	"	for X51	1
D61,62,63	MA150	Si. Diode		3
D151,251,152,252	0A90	Ge. Diode		4
D51,52,53,54	10E1-B	Si. Diode		6
67,903				
D68	RD6.8E (B3)	Zener Diode		1
D55	△RD22E (B3)	"		1
X51	△2SC1162 (BC)	Si. Transistor		1
X62	△2SC1318 (R.S)	"		1
X101,201,102,202	2SC1327 (T.U)	"		6
181,281				
X103,203,104,204	2SC1684 (R.S)	"		6
64,65				
X1,2,61,63,66	2SC1685 (R.S)	"		5
IC101,201	NE646BN	IC	Dobly NR	2
IC901	UPC4557C	"	HP & VU meter Amp	1
	VMA4114-001	Shield Plate		1
	VMA4115-001	Shield Plate		1

Other P.W. Board Parts List

Ref. No.	Parts No.	Parts Name	Remarks	Q'ty
(LED)	△ VMW1541-002B △ SLP-155B-01V	P.W.B. LED	REC	— 1
(Reed Switch)	△ VMW1541-002C	P.W.B.		1
R75	TDS271409-01	Reed Switch		1
C68	QRD147J-182S	C. Resistor		1
	OCF11HP-223	C. Capacitor		1
	TER271414-01	Spacer		1

Packing

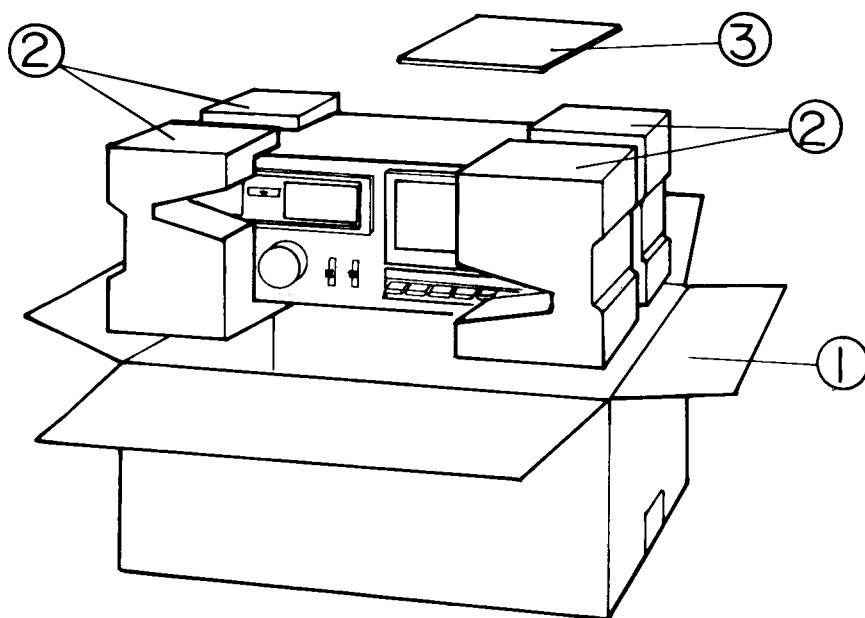

Position of control and switch knobs at renew packing.

Power switch ; OFF
 Rec level control ; MIN
 Tape select ; SA/CrO2
 DOLBY NR ; ON
 Mecha operation buttons ; OFF
 Counter ; 000.

Packing Material List

Ref. No.	Parts No.	Parts Name	Remarks	Q'ty
1~2	VPA3140-00B	Packing Case Ass'y	KD-A11A/B/E/J/U	1 set
1~2	" -00E	"	KD-A11C	1 set
1	VPA3140-003	Case	KD-A11A/B/E/J/U	1
1	" -006	"	KD-A11C	1
2	VPH2128-001	Cushion		2
	QPGA060-06005	Envelope	for set	1
	AP4056A-036	"	for power cord, provided cord	2
	QPGB024-03404	"	for Instruction Book	1
	TKS000501-01	Sheet	for set	1

Accessories

Parts No.	Parts Name	Remarks	Q'ty
VMP0002-00A	PIN Cord	KD-A11A/C/J/U	2
CN-201	DIN Cord	KD-A11B/E	1
VYA4001-00A	Head Cleaning Stick		1
VNN0062-301	Instruction Book		1
BT20029B	Warranty Card	KD-A11A	1
VND4013-001	Warning Label	KD-A11A	1
T46328-003	Caution Label	KD-A11A/B	1
VPZ4001-001	Serial Ticket	KD-A11A/J	1
BT20013C	Guarantee Certificate	KD-A11B	1
TJL000443-01	Seal	KD-A11B	1
VND4013-001	BEAB Label	KD-A11B	1
QZL1002-003BS	Warning Label	KD-A11B/E	1
T46328-005	Warning Label	KD-A11B	1
	Caution Label	KD-A11J	1
VNC5004-001	Mark Sticker	KD-A11B/E	1
VJD4011-002	Dolby NR Label	KD-A11B/C/E/J/U	1
VPZ4001-001	Serial Ticket	KD-A11B/E/U	1
BT20025C	Warranty Card	KD-A11C	1
T44362-001	CSA Marker	KD-A11C	1
TLT000505-01	UL/CSA Caution Label	KD-A11C/J	2
T43758-003	Serial Ticket	KD-A11C	2
T46328-004	Caution Label	KD-A11E	1
BT20032B	Warranty Card	KD-A11J/U	1
BT20042	Special Replay Card	KD-A11J/U	1
E7795-1	EP Mark	KDA11U	1
V04062-001	Siemens Plug	KD-A11U	1
T46328-001	Caution Label	KD-A11U	1
VNC5311-101	Caution Card		1
BXN750110UU	JVC Mic Guide		1