

SERVICE MANUAL

PARTS LIST

PRIDE IN QUALITY

AKAI STEREO TAPE DECK

MODEL **GX-270D**

GX-270D



STEREO TAPE DECK

MODEL GX-270D

SECTION 1	SERVICE MANUAL	3
SECTION 2	PARTS LIST	27
SECTION 3	SCHEMATIC DIAGRAM.....	48

SECTION 1

SERVICE MANUAL

TABLE OF CONTENTS

I.	SPECIFICATIONS	4
II.	DISMANTLING OF UNIT	6
III.	ARRANGEMENT OF MAIN PARTS	8
IV.	MECHANISM ADJUSTMENTS	9
	1. BRAKE SOLENOID INSTALLATIONS POSITION ADJUSTMENT ...	9
	2. PINCH WHEEL PRESSURE ADJUSTMENT	9
	3. QT MICRO SWITCH (SW2) INSTALLATION ANGLE ADJUSTMENT .	9
	4. BRAKE TENSION ADJUSTMENT	10
	5. ADJUSTMENT OF REEL TABLE HEIGHT	11
	6. ADJUSTMENT OF CAPSTAN MOTOR SHAFT LOOSE PLAY	11
	7. ADJUSTMENT OF IMPEDANCE ROLLER SHAFT LOOSE PLAY	12
	8. HEIGHT ADJUSTMENT OF TAPE GUIDE ON TENSION ARM	12
	9. ADJUSTMENT OF TENSION ARM MICROSWITCH SW-9 POSITION .	12
V.	HEAD ADJUSTMENT	13
VI.	AMPLIFIER SYSTEM ADJUSTMENT	15
	1. POWER SUPPLY VOLTAGE ADJUSTMENT	15
	2. TAPE SPEED ADJUSTMENT	15
	3. RECORDING, PLAYBACK AMPLIFIER ADJUSTMENT	16
	4. PEAK LEVEL INDICATOR LIGHTING LEVEL ADJUSTMENT	17
VII.	D.C. RESISTANCE OF VARIOUS COILS	18
VIII.	CLASSIFICATION OF VARIOUS P.C. BOARDS	19
	1. P.C. BOARD INTERCHANGEABILITY CHART	19
	2. COMPOSITE VIEWS OF COMPONENTS	20
IX.	PEAK LEVEL INDICATOR OPERATION	25

For basic adjustments, measuring methods, and operating principles, refer to GENERAL OPERATING PRINCIPLES AND ADJUSTMENTS.

I. SPECIFICATIONS

An asterisk next to a figure indicates the minimum guaranteed performance.

TRACK SYSTEM		4 track 2 channel stereo system
TAPE SPEED		7-1/2 and 3-3/4 ips. $\pm 0.7\%$ *7-1/2 ips. (19 cm/sec) $\pm 1.0\%$ *3-3/4 ips. (9.5 cm/sec) $\pm 1.5\%$
WOW AND FLUTTER		Less than 0.07% RMS at 7-1/2 ips. Less than 0.10% RMS at 3-3/4 ips. *Less than 0.10% at 7-1/2 ips. (FWD) *Less than 0.12% at 7-1/2 ips. (REV) *Less than 0.15% at 3-3/4 ips. (FWD) *Less than 0.18% at 3-3/4 ips. (REV)
TOTAL WOW AND FLUTTER		*Less than 0.12% at 7-1/2 ips. *Less than 0.18% at 3-3/4 ips.
FREQUENCY RESPONSE		30 to 23,000 Hz ± 3 dB at 7-1/2 ips. 30 to 19,000 Hz ± 3 dB at 3-3/4 ips. (Using AKAI LN-150-7 tape) 30 to 22,000 Hz ± 3 dB at 7-1/2 ips. 30 to 18,000 Hz ± 3 dB at 3-3/4 ips.
DISTORTION		Less than 1.0%
TOTAL DISTORTION		Less than 1.5% at 7-1/2 ips. Less than 2.5% at 3-3/4 ips.
S/N RATIO		Better than 54 dB *Better than 50 dB
TOTAL S/N RATIO		*Better than 45 dB
OUTPUT	LINE	0.775V (0 \pm 1 dB/0 \pm 1.5 dB, FWD/REV) 700 Hz "0" VU pre-recorded tape, output volume maximum.
	DIN	0.5V
INPUT	MIC	More than 0.3 mV
	LINE	More than 70 mV
	DIN	More than 3 mV (At "0" VU output, recording volume maximum)
RECORDING/PLAYBACK LEVEL		0.775V (0 \pm 1.5 dB)
CROSS TALK		Better than 40 dB (1,000 Hz, +3 VU recording)
ERASE RATIO		Better than 70 dB (1,000 Hz, +3 VU recording)
PEAK LEVEL INDICATOR		+8 VU \pm 1 dB
RECORDING BIAS FREQUENCY		100 \pm 10 kHz
BIAS LEAK		Better than -30 dB
HIGH RANGE DEVIATION		Within 3 dB (8,000 Hz 3-3/4 ips. tape at 7-1/2 ips.)
RECORDING TIME		90 minutes stereo recording using, a 1,800 ft. tape at 7-1/2 ips.
FAST FORWARD AND REWIND TAPE		Approximately 120 seconds using, a 1,800 ft. tape at 50 Hz.
MOTOR	MAIN MOTOR	2 speed A.C. Servo Control Outer Rotor Motor Type: SCM2-24KJ 4 pole Revolutions: 615 r.p.m. at 7-1/2 ips. (19 cm/sec.) 307.5 r.p.m. at 3-3/4 ips. (9.5 cm/sec.)
	REEL MOTOR	Two 6 pole eddy current Outer Rotor Motors Type: 24XO-MR Revolutions: 930 r.p.m. at 50 Hz. 1,120 r.p.m. at 60 Hz.
HEAD	RECORDING/ERASE COMBINATION HEAD	Type: RE4-6 Gap: Rec; 4 μ Erase; Double Gap Impedance: Rec; 1,400 Ω \pm 25% at 100 kHz. Erase; 130 Ω \pm 7% at 100 kHz. D.C. Resistance: Rec; 5.5 Ω Erase; 1.8 Ω
	PLAYBACK HEAD	Type: P4-202 Gap: 1.7 \pm 0.5 μ Impedance: 1,400 Ω at 1 kHz D.C. Resistance: 268 Ω

TRANSISTOR	2SA564 (Q) (R)	1	2SC1247A (B) (V)	1
	2SC458LG (C)	16	2SD361 (D) (E)	1
	2SC945 (P) (Q) (R) . . .	30	2SD361 (D1) (D2)	1
	2SC1211 (D) (E)	1	T1P48	1
DIODE	1N34A	2	10D2	3
	1S1588	1	10D4	7
	1S2473	25	RD5A (M)	1
	1S2473VE	16	WZ075	2
	10D05	5	GL-31AR	1
POWER REQUIREMENTS AND CONSUMPTION	100 to 240V A.C. 50/60 Hz, 90W (universal models)			
	240V A.C., 50 Hz, 90W (BSI models)			
	220V A.C., 50 Hz, 90W (CEE models)			
	120V A.C., 60 Hz, 90W (CSA models)			
	100V A.C. 50/60 Hz, 60/65W (Japan models)			
DIMENSIONS	441(W) x 404(H) x 210(D) mm			
	(17.4" x 15.9" x 8.3") (Dimensions include all protruding parts)			
WEIGHT	15.6 kg (34.3 lbs.)			

- NOTES: 1. Specifications determined with Scotch #211 tape unless otherwise noted.
2. Specifications Subject to change without notice.

II. DISMANTLING OF UNIT

In case of trouble, etc. necessitating disassembly, please disassemble in the order shown in photographs. Reassemble in reverse order.

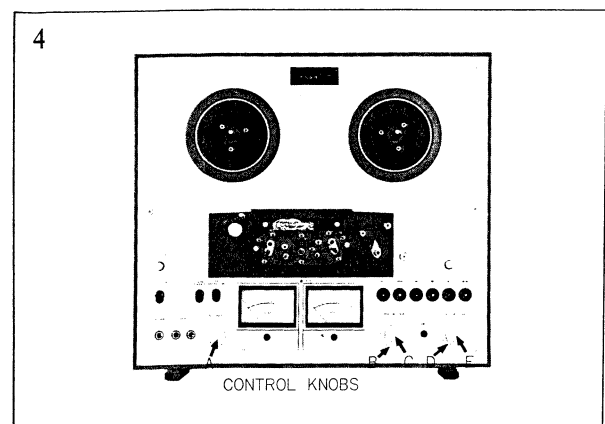
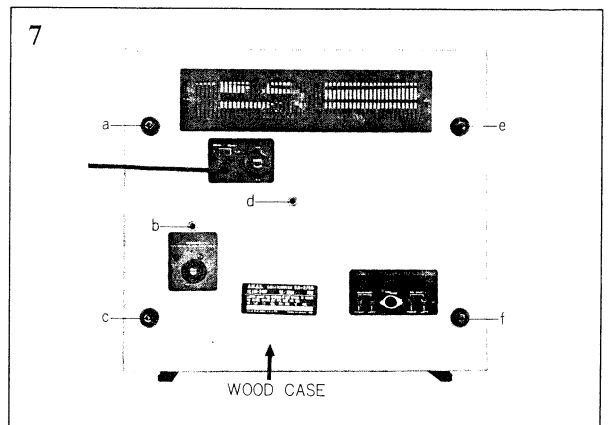
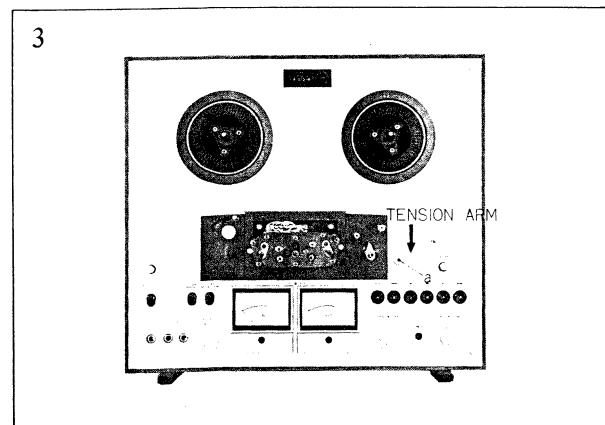
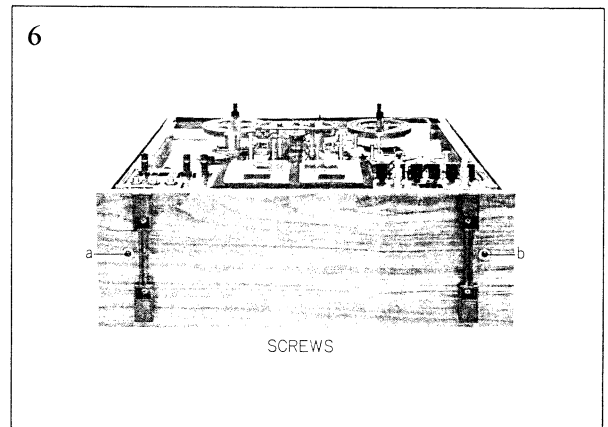
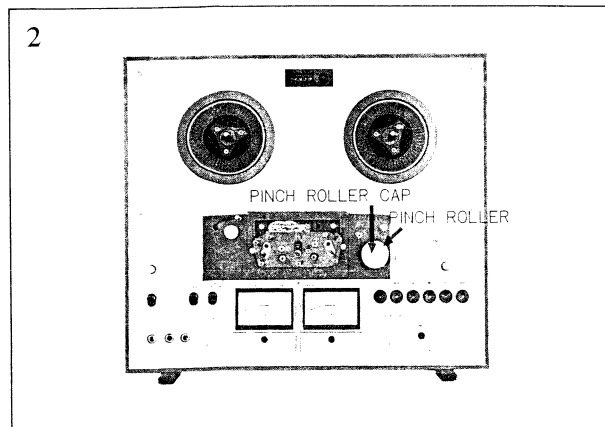
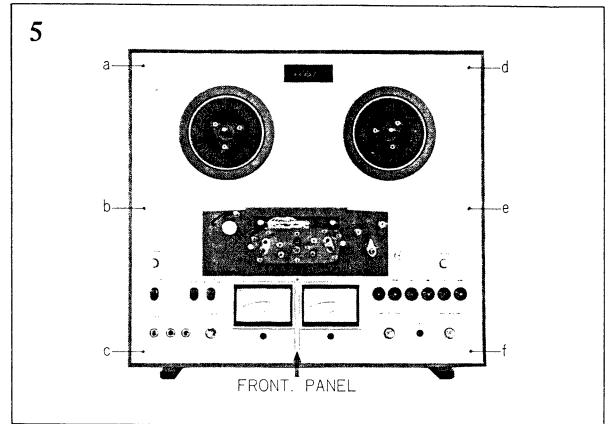
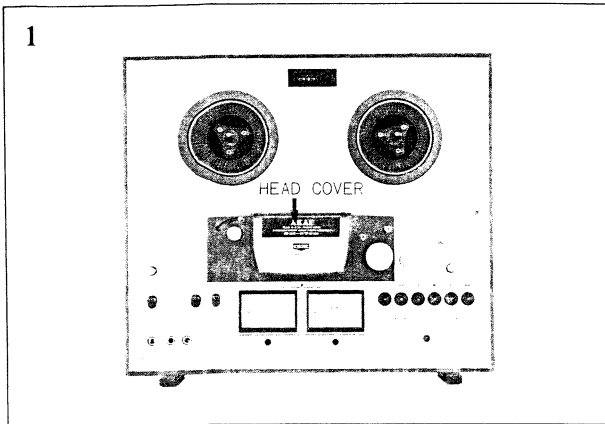

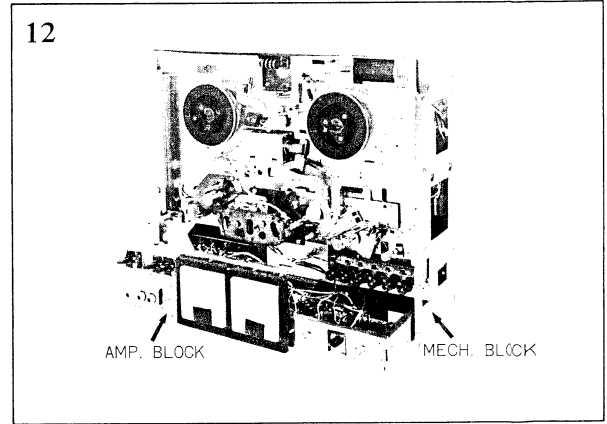
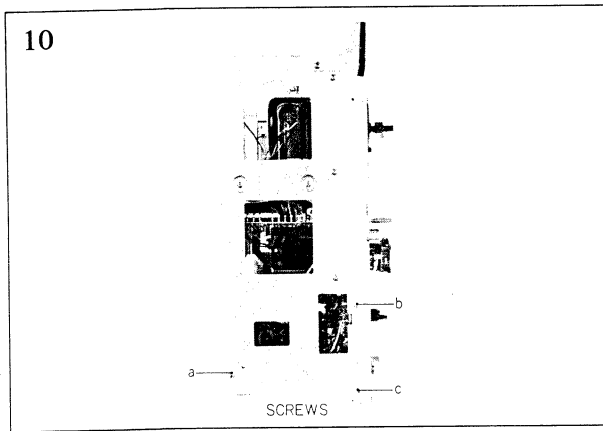
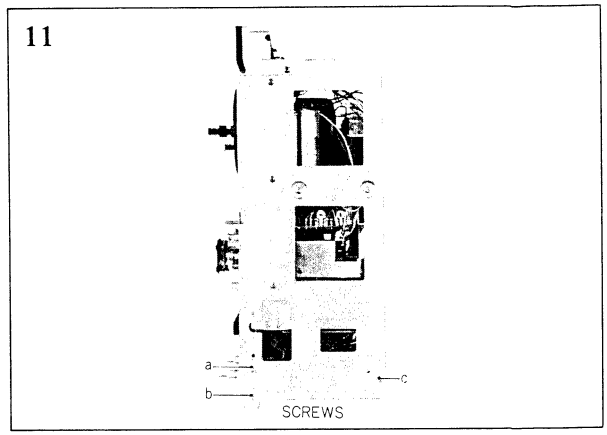
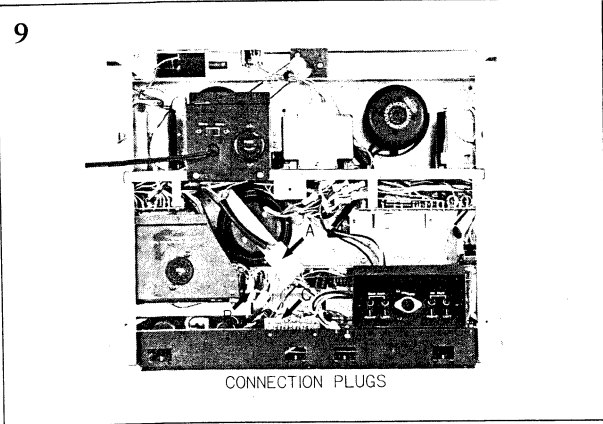

III. ARRANGEMENT OF MAIN PARTS

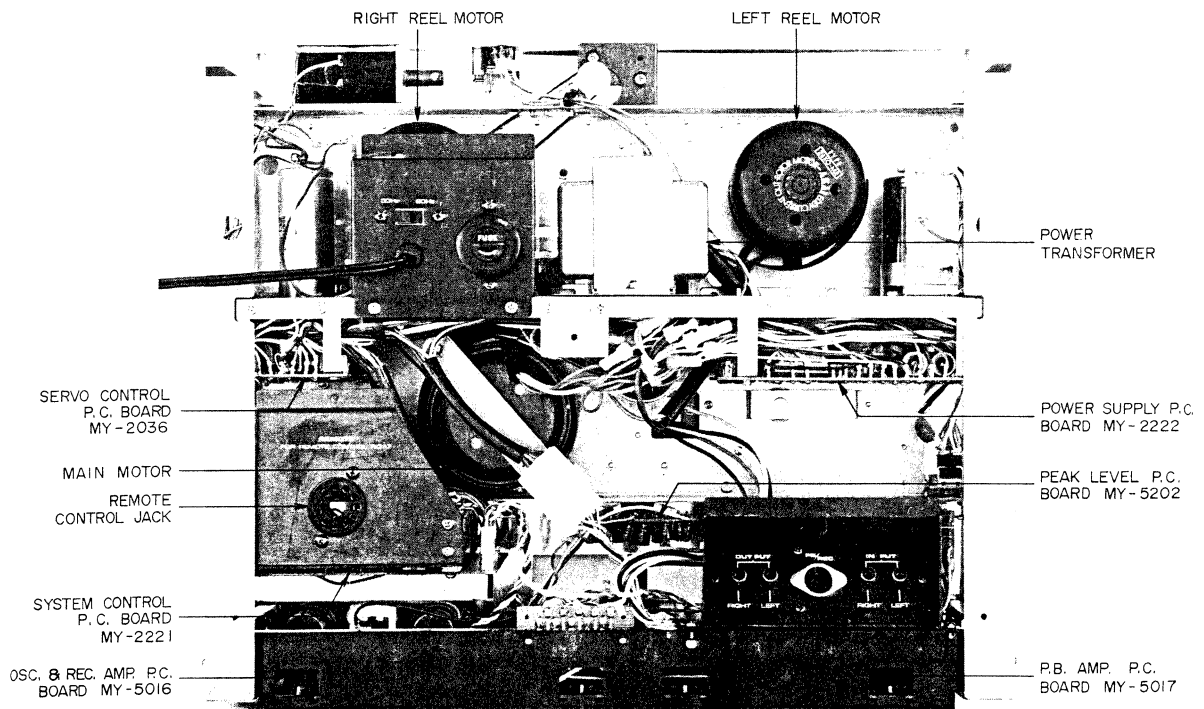
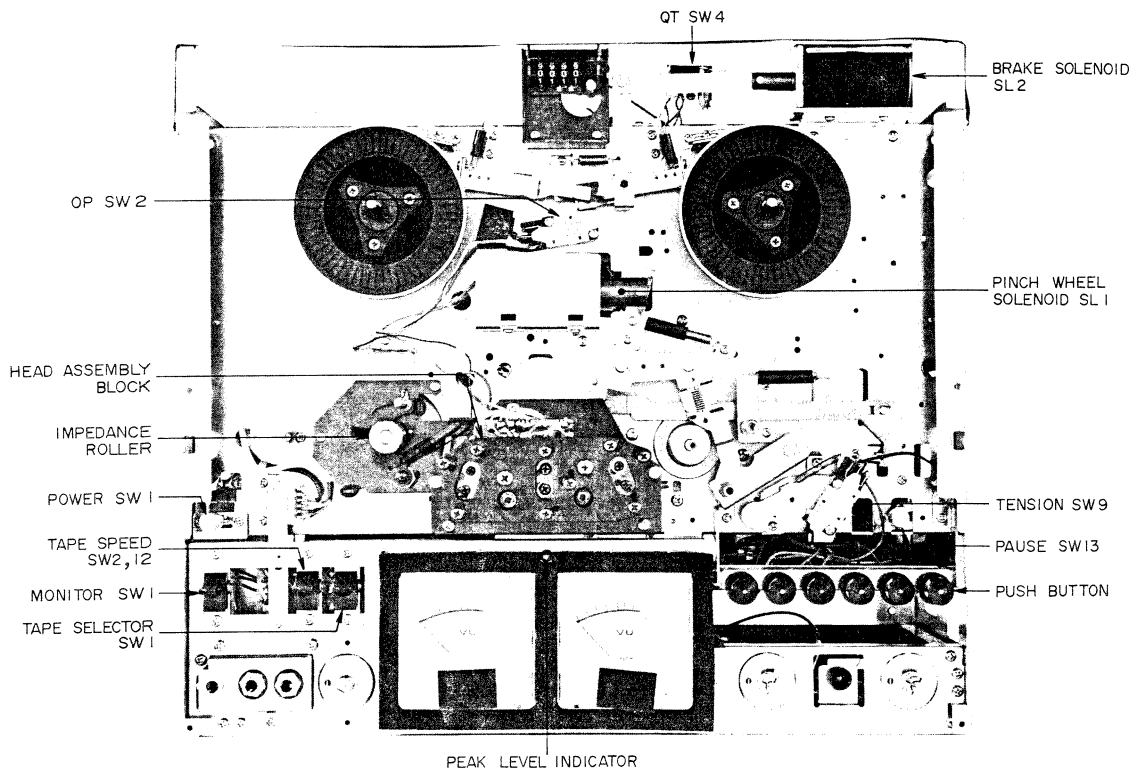

IV. MECHANISM ADJUSTMENTS

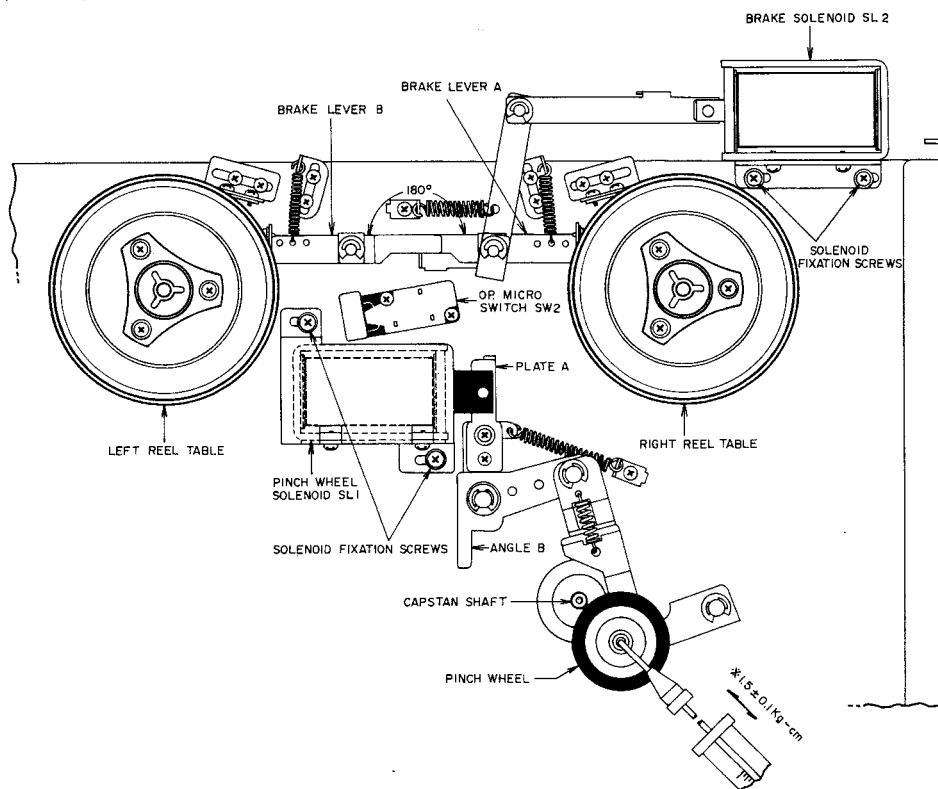

Fig. 1

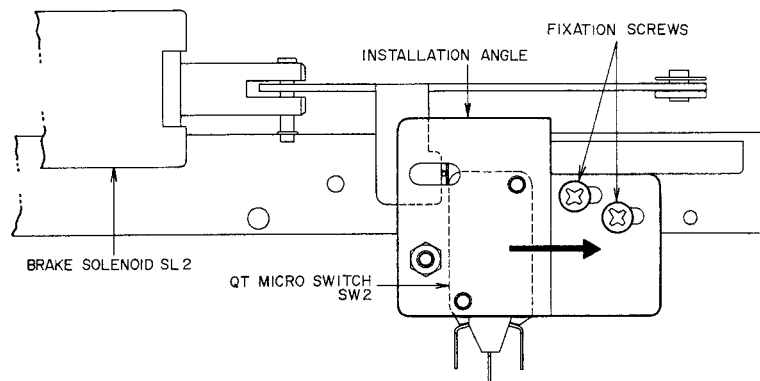

Fig. 2

1. BRAKE SOLENOID INSTALLATIONS POSITION ADJUSTMENT (Refer to Fig. 1)

At play mode, confirm that Brake Lever A and Brake Lever B display 180° angle relative.

If necessary, adjust brake solenoid installation position.

2. PINCH WHEEL PRESSURE ADJUSTMENT (Refer to Fig. 1)

1) At play mode, confirm that Plate A and Angle B display 180° angle relative.

2) Adjust pinch wheel solenoid installation position so that pinch wheel pressure is 1.5 ± 0.1 kgr-cm.

3. QT MICRO SWITCH (SW2) INSTALLATION ANGLE ADJUSTMENT (Refer to Fig. 2)

As shown in the figure, position as far toward the arrow mark as possible and fix at that position.

Caution: If this installation position is not proper, the QT micro switch will be damaged when stop is effected from play mode, etc.

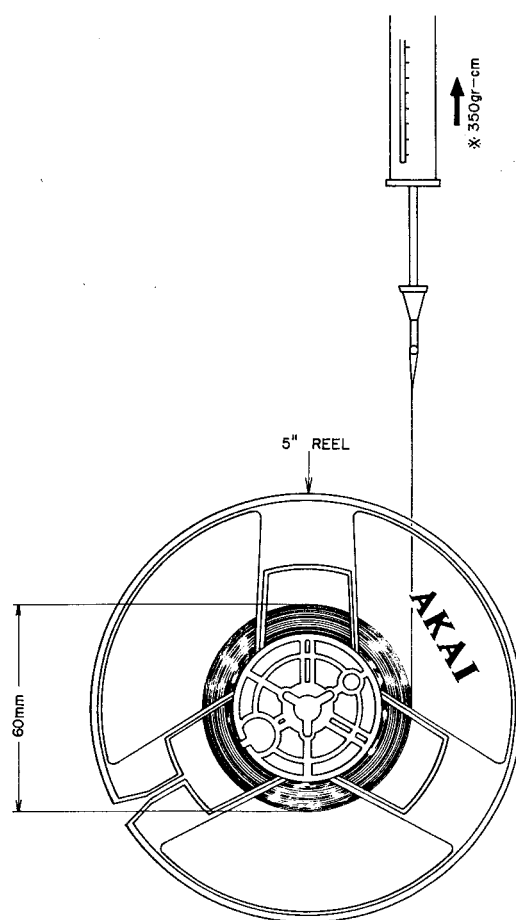

Fig. 3

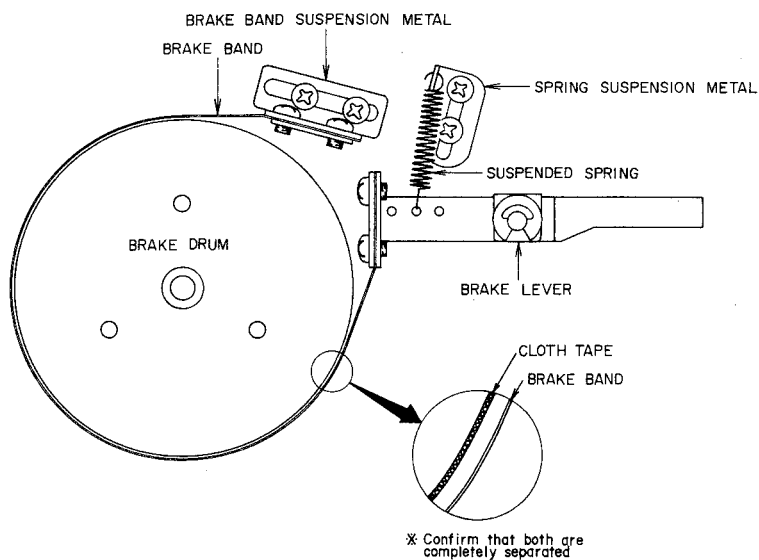

Fig. 4

4. BRAKE TENSION ADJUSTMENT (Refer to Figs. 3 and 4)

1) As shown in Fig. 3, use a 60 mm diameter of tape wound on a 5" reel and set both left and right brake tension to approximately 350 gr-cm. Deviation of left and right tension must be within 50 gr-cm.

2) Brake tension can be adjusted by changing position of the Suspended Spring.

If necessary, change the position of the Spring Suspension Metal or replace the spring.

3) At all modes except stop mode, confirm that neither of the brake bands touch the cloth tape around the brake drums.

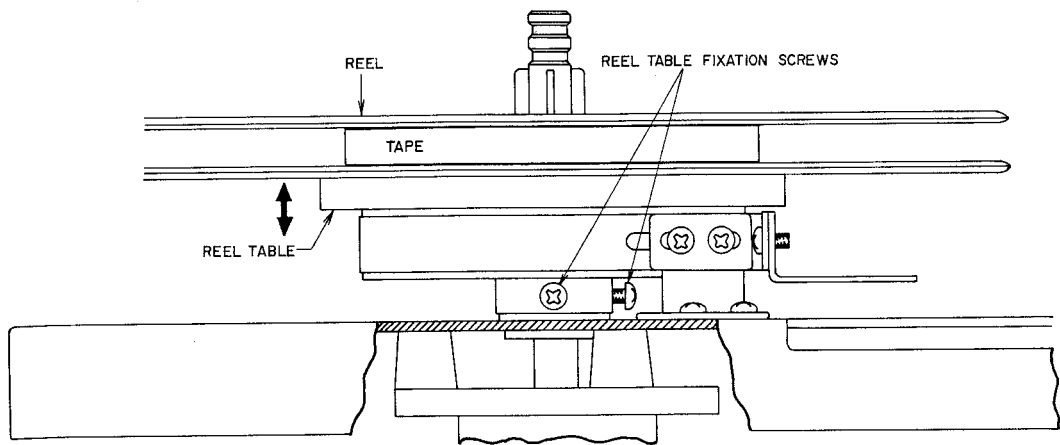

Fig. 5

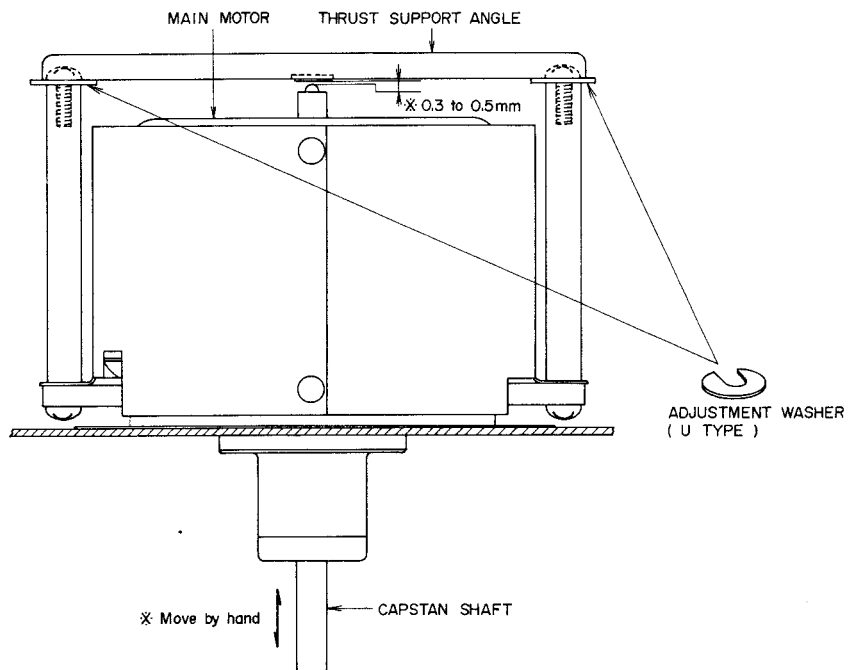

Fig. 6

5. ADJUSTMENT OF REEL TABLE HEIGHT (Refer to Fig. 5)

- 1) Properly load a tape and move the reel table as indicated by the arrow mark in Fig. 5.
 - 2) Fasten Reel Table Fixation Screws to maintain optimum position at F. FWD and RWD modes.
- NOTE: Tape should wind on center of reel regardless of type reel used.

6. ADJUSTMENT OF CAPSTAN MOTOR SHAFT LOOSE PLAY

As shown in Fig. 6, adjust the loose play by inserting an adjustment washer (U type) to obtain a 0.3 to 0.5 mm degree of loose play when the capstan shaft is moved by hand.

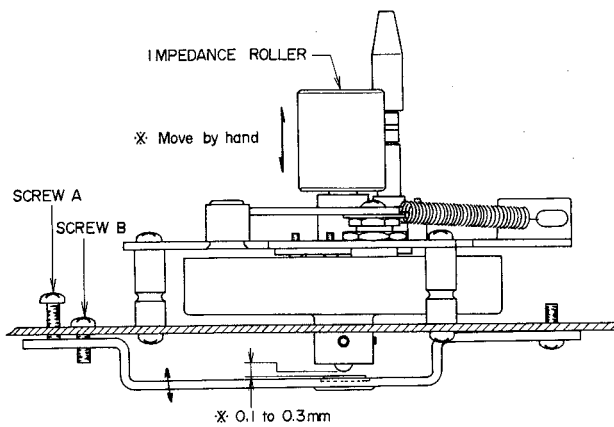

Fig. 7

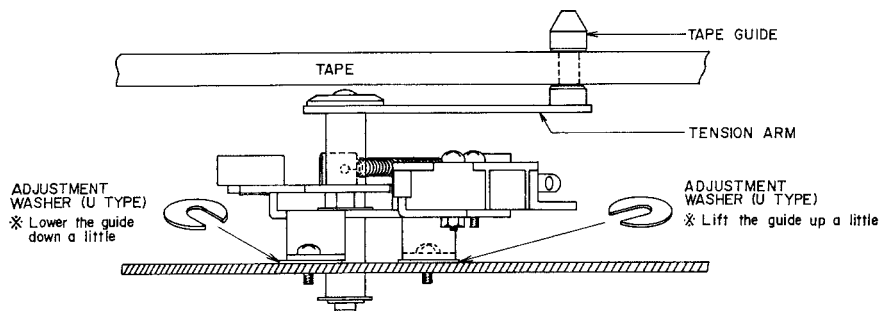

Fig. 8

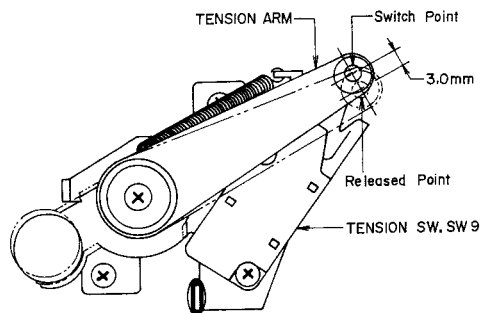

Fig. 9

7. ADJUSTMENT OF IMPEDANCE ROLLER SHAFT LOOSE PLAY (Refer to Fig. 7)

Adjust by turning adjustment screws A and B to obtain a 0.1 to 0.3 mm degree loose play when the shaft is moved by hand.

NOTE: Both A and B screws must be tightened after this procedure.

8. HEIGHT ADJUSTMENT OF TAPE GUIDE ON TENSION ARM

Adjust the height of Tape Guide on Tension Arm by inserting an adjustment washer (U type) as shown in Fig. 8 so that tape travels on the center of the tape guide.

9. ADJUSTMENT OF TENSION ARM MICROSWITCH SW-9 POSITION

Confirm that the microswitch operates at the position indicated in Fig. 9.

If necessary, move the microswitch to obtain optimum position.

V. HEAD ADJUSTMENT

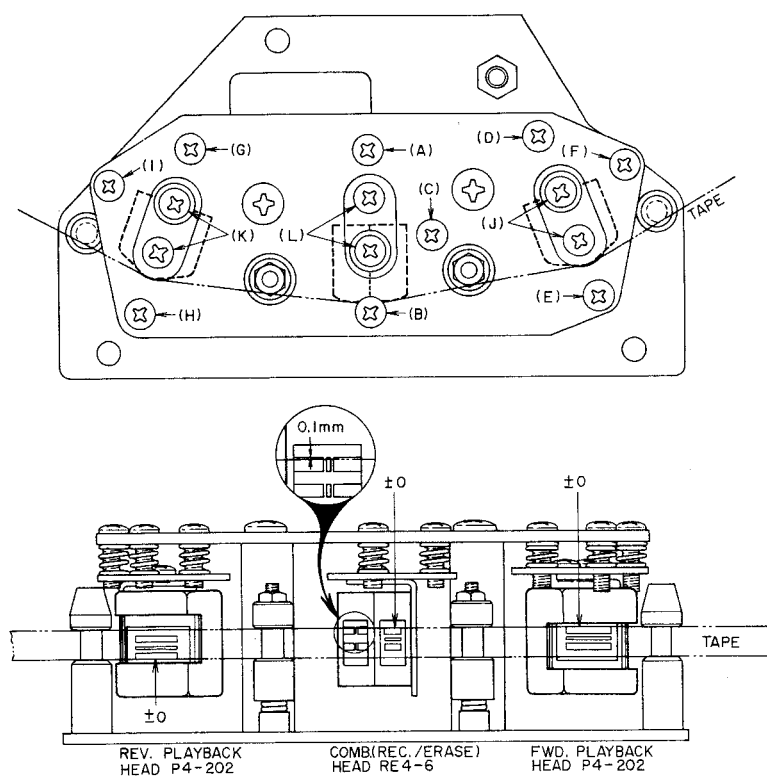

Fig. 10

NOTES:

- 1) As perfect head adjustments are vital in attaining top tape deck performance, please be sure that these adjustments are properly carried out.
- 2) Be careful not to use a magnetized screw driver or other magnetized tools in the vicinity of the heads.
- 3) Use only new tape as level variation is likely to occur when using old tape.
- 4) Demagnetize heads with a Heads Demagnetizer before and after head adjustment.

Step	Adjustment Item	Test Tape Supply Signal	Mode	Adjustment Point	Remarks
1	Combination Head Height Adjustment	optional	FWD	(A)(B)(C)	Upper edge of ch. 1 head core and the upper edge of the tape are the same height.
2	FWD Playback Head Height Adjustment	optional	FWD	(D)(E)(F)	Upper edge of ch. 1 head core and the upper edge of the tape are the same height.
3	REV Playback Head Height Adjustment	optional	REV	(G)(H)(I)	Lower edge of ch. 1 head core and the lower edge of the tape are the same height.
4	FWD Playback Head Azimuth Alignment Adjustment	8,000 Hz, 3-3/4 ips test tape	FWD	(F)	Maximum output, both channels.
5	FWD Playback Head Gap Alignment Adjustment	8,000 Hz, 3-3/4 ips test tape	FWD	(J)	Adjust head gap surface so that there is no change in output level when tension is applied to the supply reel side.
6	REV Playback Head Azimuth Alignment Adjustment	8,000 Hz, 3-3/4 ips test tape	REV	(I)	Maximum output, both channels.
7	REV Playback Head Gap Alignment Adjustment	8,000 Hz, 3-3/4 ips test tape	REV	(K)	Adjust head gap surface so that there is no change in output level when tension is applied to the supply reel side.
8	Combination Head Azimuth Alignment Adjustment	Scotch #211 tape 15,000 Hz -20 dBm	REC	(C)	Maximum output, both channels.
9	Combination Head Gap Alignment Adjustment	Scotch #211 tape 15,000 Hz -20 dBm	REC	(L)	Adjust head gap surface so that there is no change in output level when tension is applied to the supply reel side.

NOTE: Set tape speed to 7-1/2 ips. when making all alignment adjustments.

VI. AMPLIFIER SYSTEM ADJUSTMENT

1. POWER SUPPLY VOLTAGE ADJUSTMENT

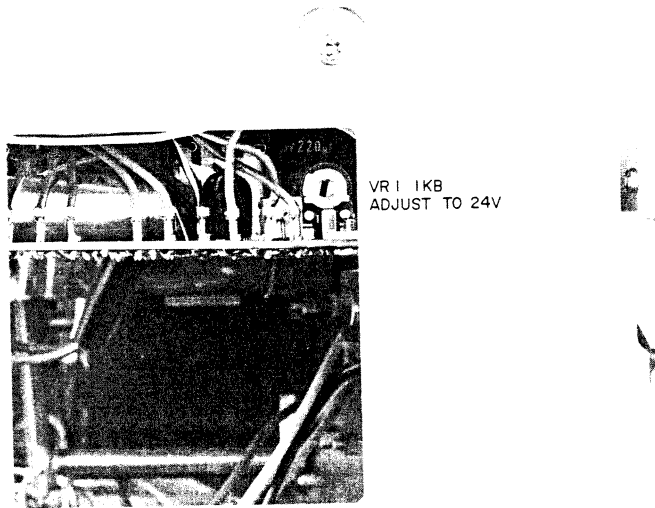
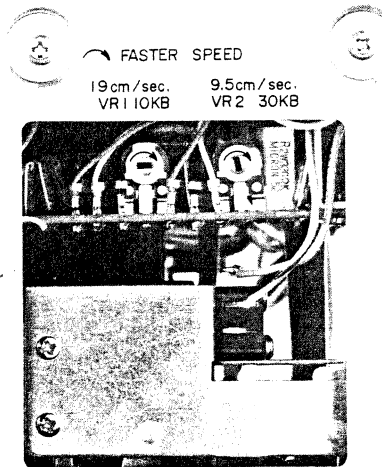

Fig. 11

2. TAPE SPEED ADJUSTMENT



19 cm/sec. $\pm 1\%$
9.5 cm/sec. $\pm 1.5\%$ Fig. 12

Step	Adjustment Item	Test Tape	Mode	Adjustment Point	Result	Remarks
1	Power Supply Voltage Adjustment		STOP	VR1 1 kB	24.0V	Terminal (39), Power Supply P.C. Board
2	7-1/2 ips Tape Speed Adjustment	1,000 Hz, 7-1/2 ips test tape	FWD P.B.	VR1 10 kB	1,000 Hz $\pm 1.0\%$	Tape Speed 7-1/2 ips.
3	3-3/4 ips Tape Speed Adjustment	1,000 Hz, 7-1/2 ips test tape	FWD P.B.	VR2 30 kB	500 Hz $\pm 1.5\%$	Tape Speed 3-3/4 ips.

3. RECORDING, PLAYBACK AMPLIFIER ADJUSTMENT

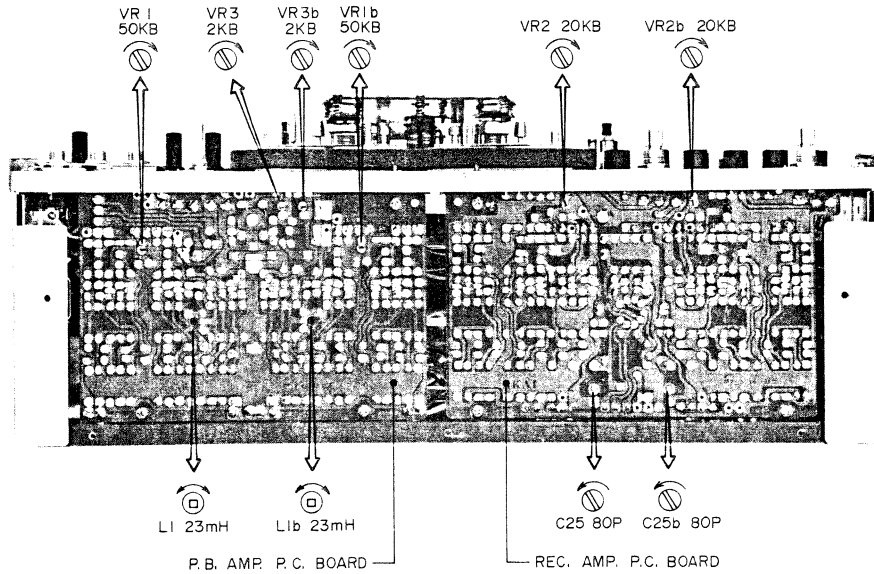

Fig. 13

Step	Adjustment Item	Test Tape Supply Signal	Mode	Adjustment Point	Result	Remarks
1	Playback Level Adjustment	700 Hz, 7-1/2 ips. "0" VU test tape	FWD P.B.	VR1 50 kB	0±1.0 dB (0.775V)	Within 0±1.5 dB at reverse playback
2	VU Meter Sensitivity Adjustment	700 Hz, 7-1/2 ips. "0" VU test tape	FWD P.B.	VR3 2 kB	"0" VU	
3	Recording Level Adjustment	Scotch #211 tape, 1,000 Hz "0" VU recording	REC	VR2 20 kB	0±1.5 dB (0.775V)	Monitor Switch at SOURCE
4	Frequency Response Adjustment	Scotch #211 tape, 1,000 Hz, 10,000 Hz -20 dBm recording	REC	C25 80P	1,000 Hz to 10,000 Hz flat	Re-adjust recording level following bias adjustment
5	Bias Leak Adjustment		REC	L1 23 mH	Less than -30 VU	With Monitor Switch at TAPE and SOURCE positions

NOTES:

1. Tape Speed at 7-1/2 ips. (19 cm/sec.)
2. Tape Selector at LOW NOISE.
3. Output volume maximum.
4. New test tape should be used.
5. The letter b following an adjustment parts number indicates "right channel".

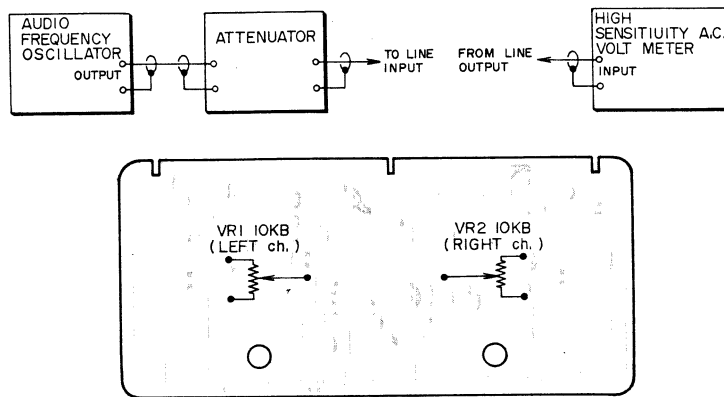

Fig. 14

4. PEAK LEVEL INDICATOR LIGHTING LEVEL ADJUSTMENT (Refer to Fig. 14)

- 1) Connect measuring instruments as shown in Fig. 14 above.
- 2) Set Output Volume to maximum (turn fully clockwise)
- 3) Set Monitor Switch to SOURCE.
- 4) Set Line Controls to 12 o'clock position.
- 5) Supply a 1,000 Hz sine wave signal from the Audio Frequency Oscillator and adjust Peak Level P.C. Board semi-fixed resistor so that the Level Indicator lamp lights when the High Sensitivity A.C. Voltmeter indication reaches 8 dBm.

VR1 10 kB: Left channel

VR2 10 kB: Right channel

* Peak level indicator lighting level specification is 8 ± 1 dBm.

NOTE: Because left-right channel adjustment semi-fixed resistors are separate, adjust respective channels accordingly.

VII. D.C. RESISTANCE OF VARIOUS COILS

Part	Designation	D.C. Resistance
Main Motor	SCM2-24KJ	Between BLU-RED 100 ohm Between YLW-GRN 180 ohm Pick-up Coil 635 ohm
Reel Motor	24XO-MR	Between BLU-RED 74 ohm Between YLW-GRN 166 ohm
Pinch Wheel Solenoid	1660THT3	685 ohm
QT Solenoid	KGS 10CM 1,300 ohm	1,300 ohm
RELAY	MY4-O-US-AD4 DC24V	650 ohm
RELAY	MTS-2	980 ohm
Headphone Output Transformer	N16-535S	Primary 565 ohm $\pm 15\%$ Secondary 0.95 ohm $\pm 15\%$
Oscillator Coil	OT-204	Between 1 – 3 0.3 ohm Between 4 – 6 0.7 ohm Between 7 – 9 8.2 ohm
Playback Head	P4-202	268 ohm
Recording/Erase Combination Head	RE4-6	REC 5.5 ohm Erase 1.8 ohm

NOTE: Resistance values shown in this chart are average values.

VIII. CLASSIFICATION OF VARIOUS P.C. BOARDS

1. P.C. BOARD INTERCHANGEABILITY CHART

P.C. Board	Designation
Relay P.C. Board	MY-0008
Servo Control P.C. Board	MY-2036
Transistor P.C. Board	MY-2054
Equalizer P.C. Board	MY-5014A.B
OSC. and Recording Amp. P.C. Board	MY-5016
Playback Amp. P.C. Board	MY-5017
System Control P.C. Board	MY-2221
Power Supply P.C. Board	MY-2222
Peak Level P.C. Board	MY-5202

2. COMPOSITE VIEWS OF COMPONENTS

1) OSC. AND REC. AMP. P.C. BOARD MY-5016

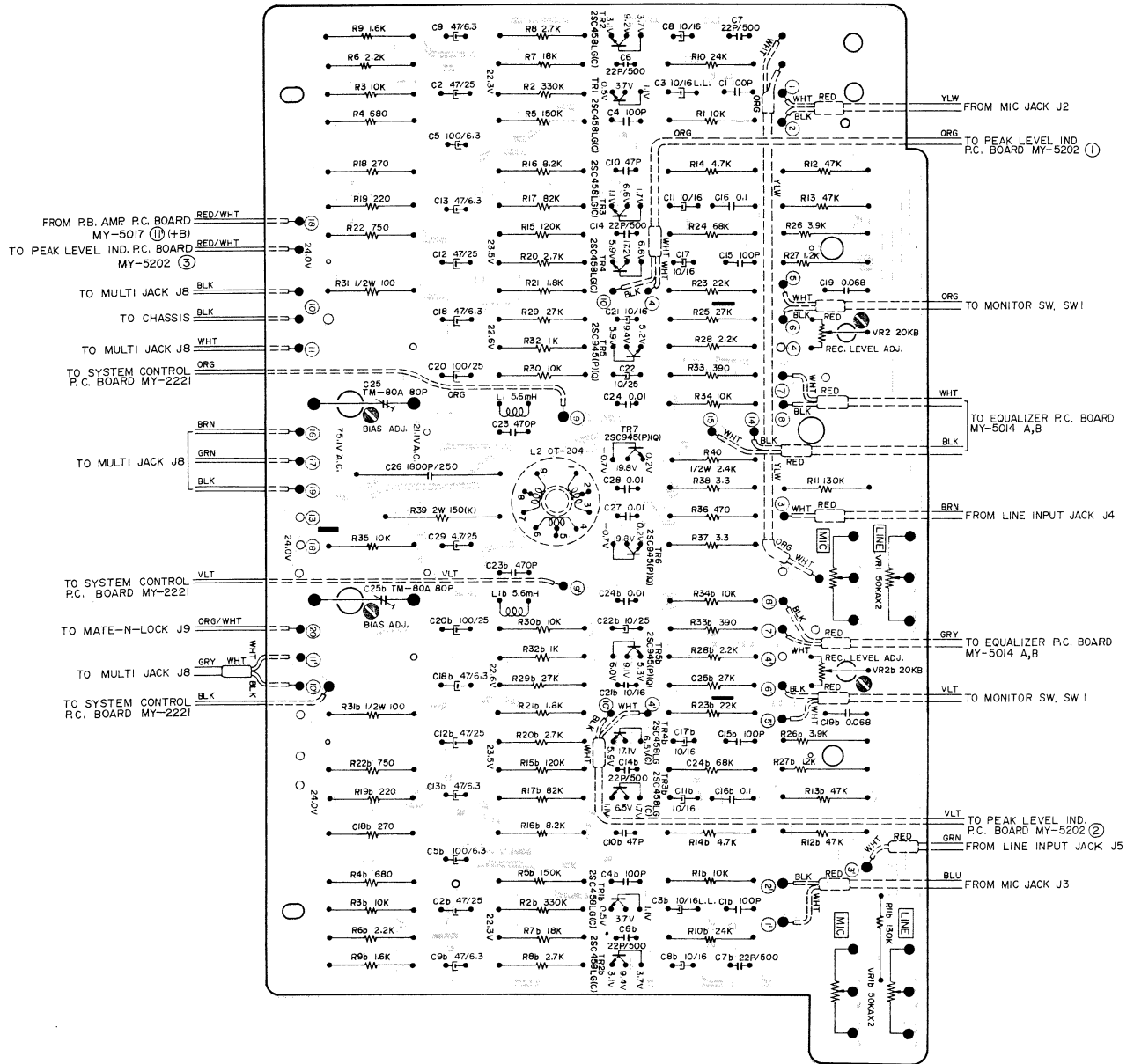

2) PLAYBACK AMP. P.C. BOARD MY-5017

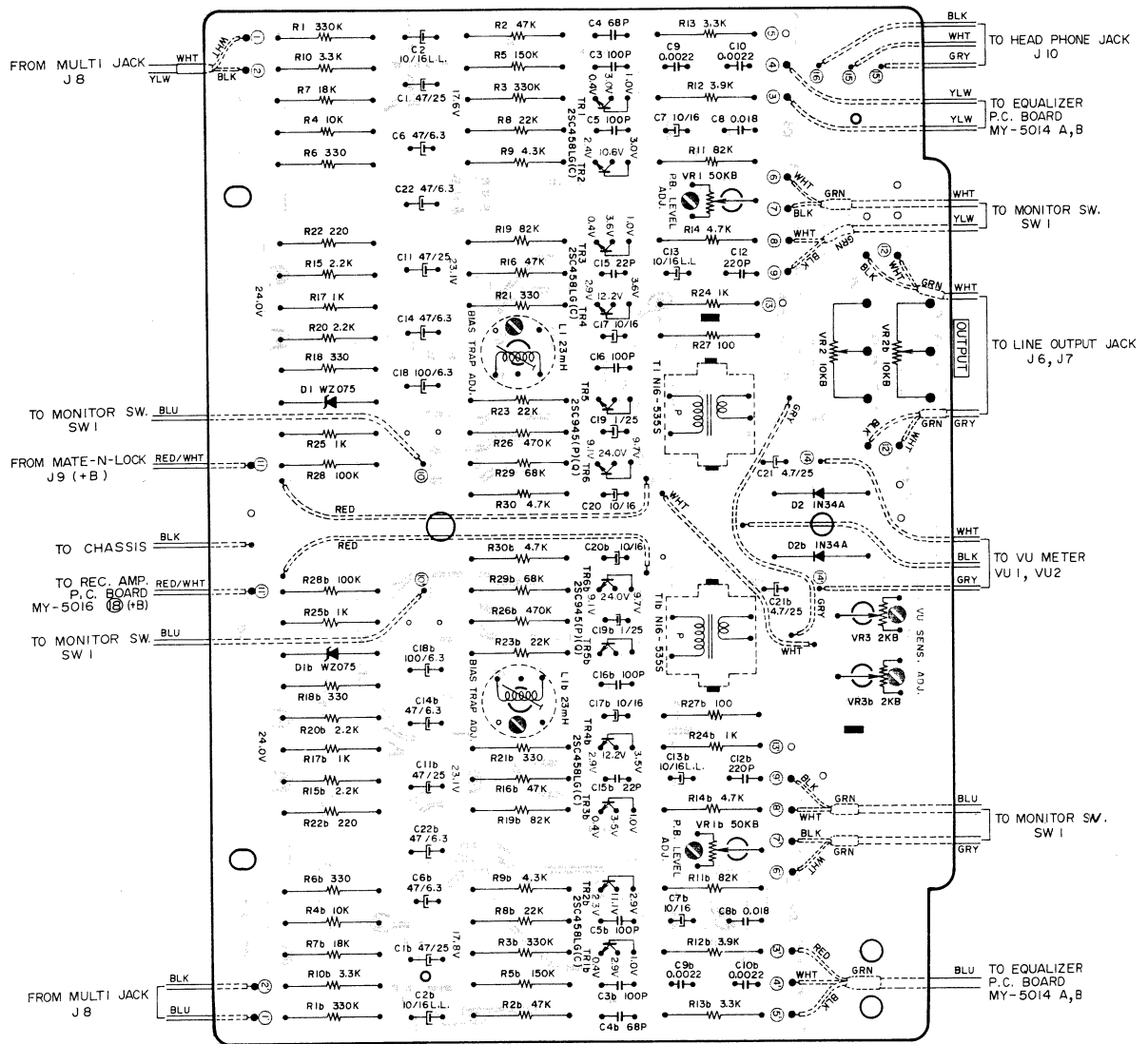

3) PEAK LEVEL P.C. BOARD MY-5202

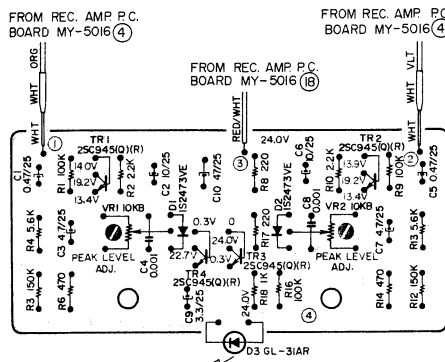

4) POWER SUPPLY P.C. BOARD MY-2222

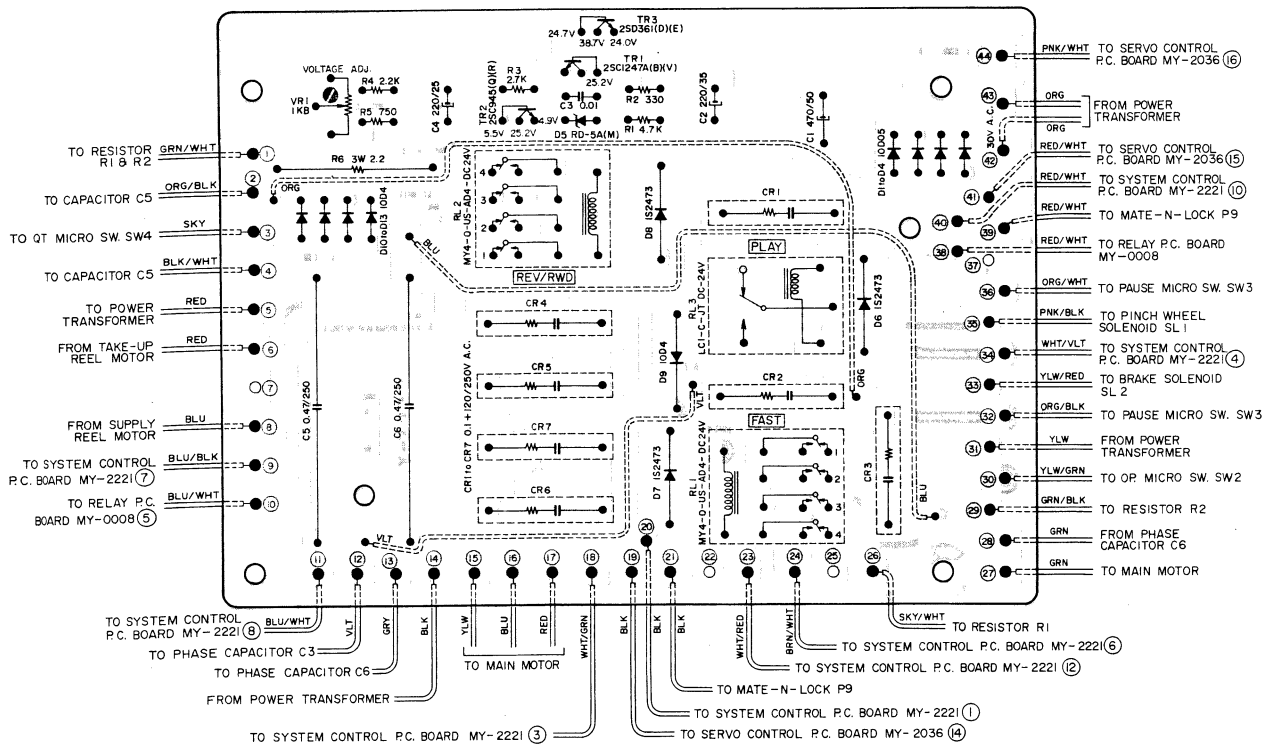

5) SERVO CONTROL P.C. BOARD MY-2036

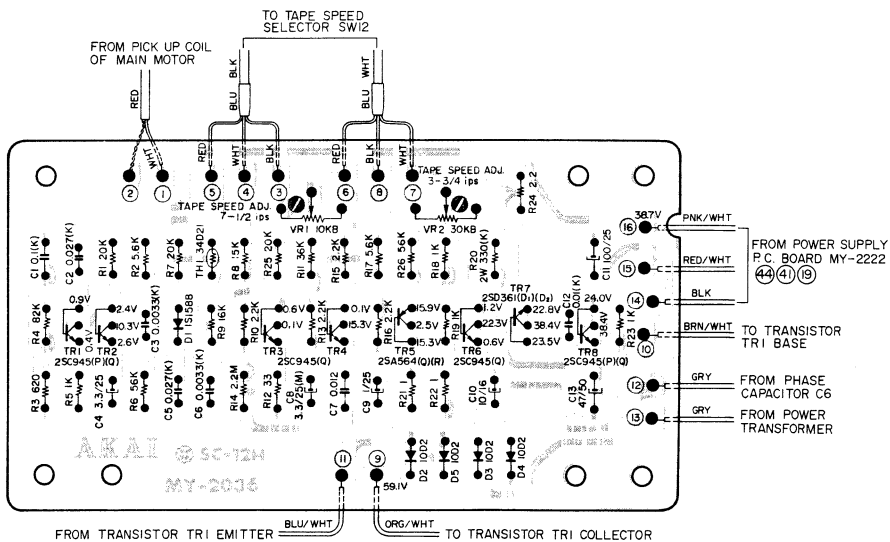

6) SYSTEM CONTROL P.C. BOARD MY-2221

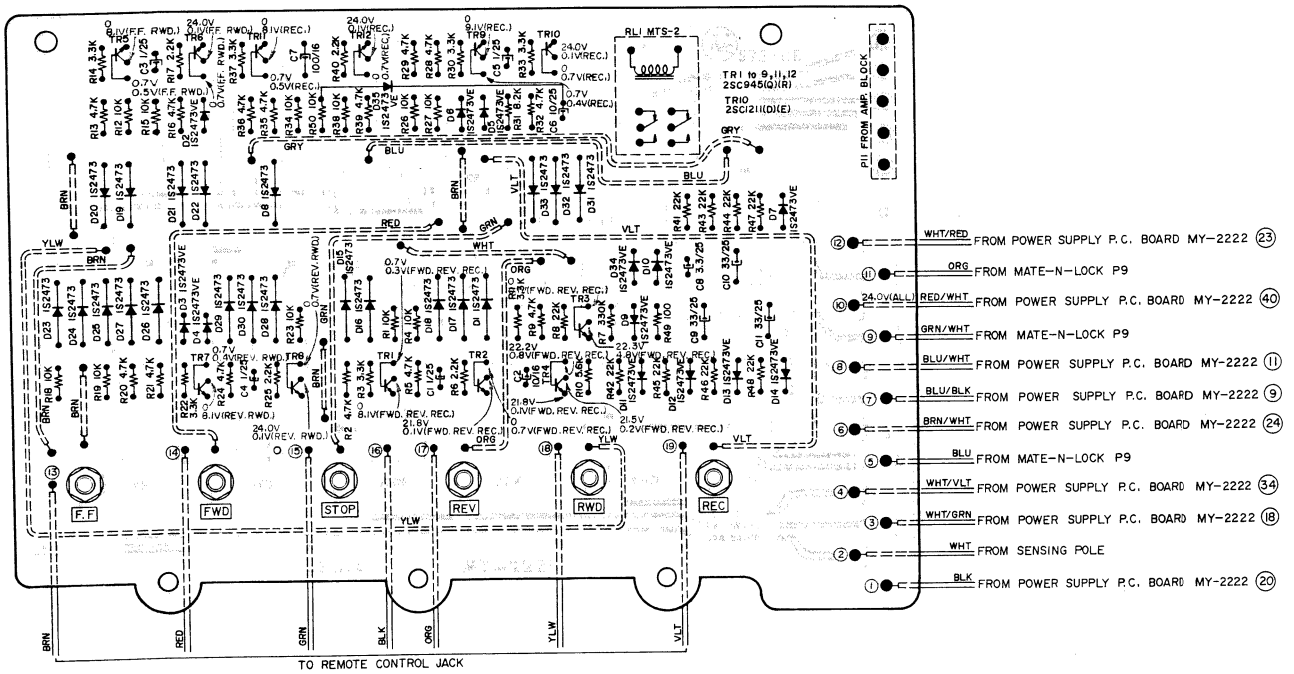

7) RELAY P.C. BOARD MY-0008

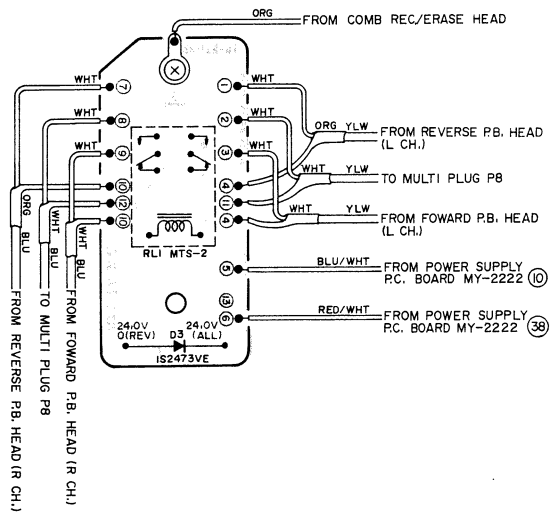

8) EQUALIZER P.C. BOARD MY-5014 A, B

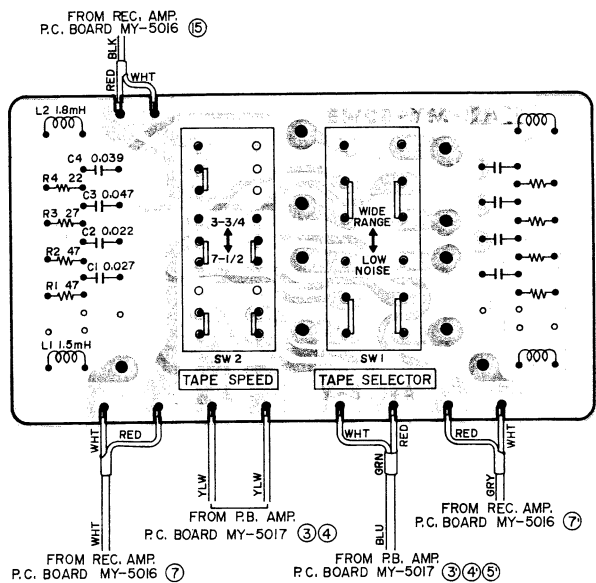

9) TRANSISTOR P.C. BOARD MY-2054

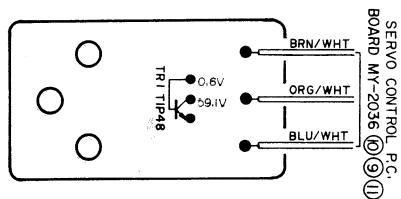

IX. PEAK LEVEL INDICATOR OPERATION

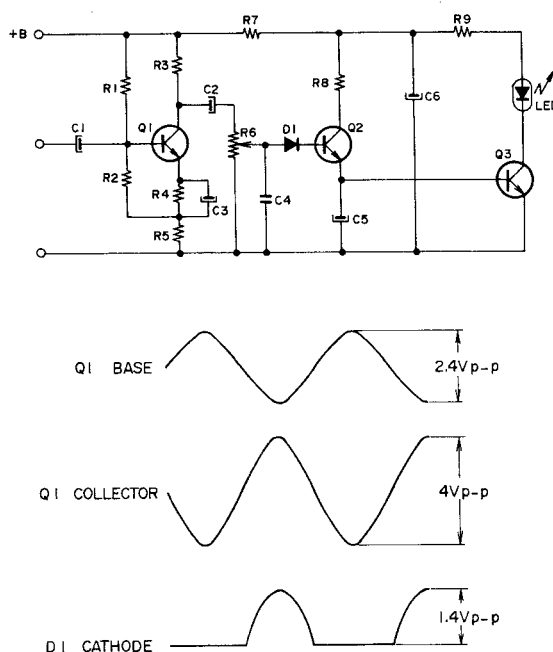

Fig. 15

For optimum recording quality, ideal recording level setting is necessary. However when pulsive signals are introduced, VU Meters do not always accurately register these signals.

Also when recording using the full dynamic margin of the tape is desired, over-recording, which is the source of distortion, is likely to occur. Thus, the peak level indicator is for the purpose of observing the actual peak level for better recording results.

- 1) The peak level indicator circuit is shown in Fig. 15, and is comprised of ordinary Amp (Q1), rectifier diode (D1), switching circuit (Q2, Q3) and luminous diode (LED).
- 2) When the recording signal reaches +8 dBm, D.C. half-wave rectifying current is supplied to the base of transistor Q2 and Q2 lead through is effected (Q2 is turned ON) as illustrated by the lower diagram in Fig. 15.
- 3) Transistor Q2 emitter current becomes the base bias of transistor Q3 and transistor Q3 lead through is effected.
- 4) In other words, transistor Q2, Q3 switching circuit is turned ON, the current from (+B) flows to R7→R9 →LED→Q3 and luminous diode (LED) is activated.
- 5) Transistor Q2 is turned OFF at +6 dBm recording input signal and the switching takes place at +7 dBm. However, because of the slight variation in luminous diode lead through current, there is a ± 1 dBm switching point deviation.

SECTION 2

PARTS LIST

TABLE OF CONTENTS

1	HEAD BLOCK.....	30
2	REEL MOTOR/REEL TABLE BLOCK.....	31
3	MAIN MOTOR BLOCK.....	32
4	IMPEDANCE ROLLER BLOCK.....	33
5	PAUSE SW./TENSION ARM BLOCK.....	34
6	PINCH ROLLER PLUNGER BLOCK.....	35
7	OPERATION BLOCK.....	36
8	MECH. ASSEMBLY BLOCK.....	37
9	POWER SUPPLY BLOCK.....	39
10	POWER SUPPLY P.C. BOARD (MY-2222) BLOCK.....	40
11	SYS. CON. P.C. BOARD (MY-2221) BLOCK.....	40
12	SERVO P.C. BOARD (MY-2036) BLOCK.....	41
13	PEAK LEVEL P.C. BOARD (MY-5202) BLOCK.....	41
14	EQ. P.C. BOARD (MY-5014A) BLOCK.....	41
15	PB. P.C. BOARD (MY-5017) BLOCK.....	41
16	REC., OSC. P.C. BOARD (MY-5016) BLOCK.....	42
17	AMP. ASSEMBLY BLOCK.....	43
18	FINAL ASSEMBLY BLOCK.....	44
19	LIST OF INTERCHANGEABLE SEMICONDUCTORS.....	45
	INDEX.....	46

Some of the parts in this parts list are only available as a complete assembly, and can not be supplied as individual parts.

HOW TO USE THIS PARTS LIST

1. This parts list is compiled by various individual blocks based on assembly process.
2. When ordering parts, please describe parts number, serial number, and model number in detail.
3. How to read List

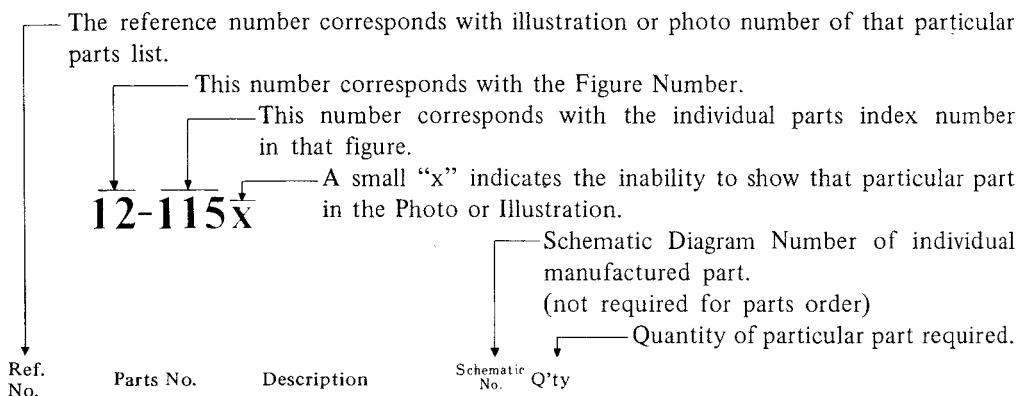

FLYWHEEL BLOCK #13				
Ref. No.	Parts No.	Description	Schematic No.	Q'ty
12-115x	800425	Flywheel Block Assy. Comp.	RDG #13	1
12-116	244506	Flywheel Only	RD-233	1
12-117x	244754	Felt, Flywheel	RD-275	1
12-118	251324	Main Metal Case	RD-236	1
12-119	253080	Main Metal	RD-237	1

4. The symbol numbers shown on the P.C. Board list can be matched with the Composite Views of Components of the Schematic Diagram or Service Manual.
5. Please utilize separate "Common List for Service Parts" for Resistor Parts orders.
6. The shape of the parts and parts name, etc. can be confirmed by comparing them with the parts shown on the Electrical Parts Table of P.C. Board.
7. Both the kind of part and installation position can be determined by the Parts Number. To determine where a parts number is listed, utilize Parts Index at end of Parts List.
It is necessary first of all to find the Parts Number. This can be accomplished by using the Reference Number listed at right of parts number in the Parts Index. (meaning of ref. no. outlined in Item 3 above).
8. Utilize separate "Price List for Parts" to determine unit price. The most simple method of finding parts Price is to utilize the reference number.

ELECTRICAL PARTS TABLE

<p>Because the indication of resistors and capacitors in the P.C. Board photos are being eliminated, please confirm parts name and shape by comparing them with the parts shown in this table.</p>	<p style="text-align: center;">1</p>  <p style="text-align: center;">Solid Resistor</p>	<p style="text-align: center;">2</p> <p style="text-align: right;">Stopper Type</p>  <p style="text-align: center;">Insulator Type</p> <p style="text-align: center;">Carbon Resistor</p>	<p style="text-align: center;">3</p>  <p style="text-align: center;">Metal Oxide Film Resistor</p>
<p style="text-align: center;">4</p>  <p style="text-align: center;">Cement Resistor</p>	<p style="text-align: center;">5</p>  <p style="text-align: center;">Wire-Wound Resistor</p>	<p style="text-align: center;">6</p>  <p style="text-align: center;">Thermister</p>	<p style="text-align: center;">7</p>  <p style="text-align: center;">Enamel Resistor</p>
<p style="text-align: center;">1</p>  <p style="text-align: center;">MP Capacitor (Tubular Type)</p>	<p style="text-align: center;">2</p>  <p style="text-align: center;">Plastic Capacitor</p>	<p style="text-align: center;">3</p>  <p style="text-align: center;">Mylar Capacitor</p>	<p style="text-align: center;">4</p>  <p style="text-align: center;">VFM (Hi-Q) Capacitor</p>
<p style="text-align: center;">5</p>  <p style="text-align: center;">Mylar Capacitor</p>	<p style="text-align: center;">6</p>  <p style="text-align: center;">Tantalum Capacitor</p>	<p style="text-align: center;">7</p>  <p style="text-align: center;">Oil Capacitor (Tubular Type)</p>	<p style="text-align: center;">8</p> <p style="text-align: right;">Vertical Type</p> <p style="text-align: center;">Tubular Type</p>  <p style="text-align: center;">Styrol Capacitor</p>
<p style="text-align: center;">9</p>  <p style="text-align: center;">Electrolytic Capacitor (Tubular Type)</p>	<p style="text-align: center;">10</p> <p style="text-align: right;">Vertical Type</p> <p style="text-align: center;">Tubular Type</p>  <p style="text-align: center;">Electrolytic Capacitor</p>	<p style="text-align: center;">11</p>  <p style="text-align: center;">Ceramic Capacitor</p>	<p style="text-align: center;">12</p>  <p style="text-align: center;">Metalized Mylar (Paper) Capacitor</p>
<p style="text-align: center;">13</p>  <p style="text-align: center;">Trimmer Condenser</p>		<p style="text-align: center;">VR</p>  <p style="text-align: center;">Semi-Fixed Volume</p>	
<p style="text-align: center;">L</p>  <p style="text-align: center;">Ferri Inductor</p>	<p style="text-align: center;">TR</p>  <p style="text-align: center;">Transistor</p>		
<p style="text-align: center;">CR</p>  <p style="text-align: center;">Spark Quencher</p>	<p style="text-align: center;">D</p>  <p style="text-align: center;">Diode (Silicon, Zener, Germanium)</p>		

1 ILLUSTRATION OF HEAD BLOCK

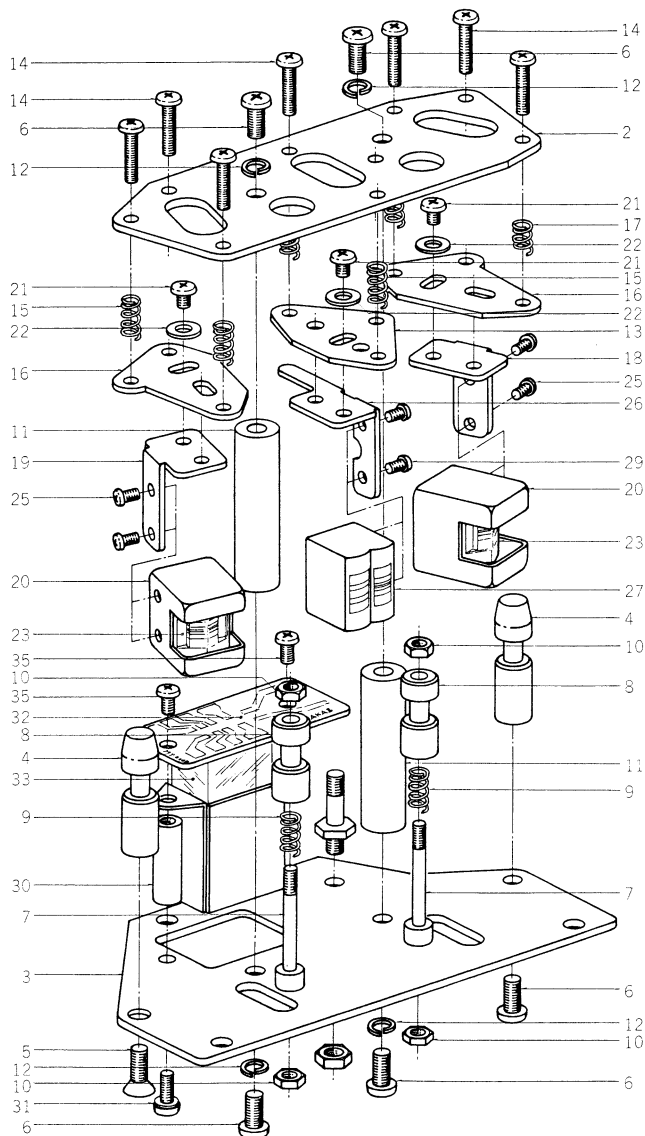

HEAD BLOCK

Ref. No.	Parts No.	Description	Schematic No.	Q'ty	Ref. No.	Parts No.	Description	Schematic No.	Q'ty
1-1x	BH622585	Head Block Comp.	MY	1	1-20	HZ627546	Head Shield	MY-0010	2
1-2	HZ626837	Head Base A	MY-0001	1	1-21	ZS608477	Screw, pan head 3x4		6
1-3	HZ626848	Head Base B	MY-0002	1	1-22	ZW413256	Washer (SPC) D3.4x7.8x0.5t		3
1-4	MS625072	Tape Guide	MY-0003	2	1-23	HP536501	PB HEAD P4-202		2
1-5	ZS414044	Screw, countersunk head 4x8		1	1-24x	EA463206	Terminal P.C. Board A	RD-A36	4
1-6	ZS413201	Screw, pan head 4x8		3	1-25	ZS201508	Screw, pan head 2x4		4
1-7	MH573957	Tape Guide Prop	TD-0003	2	1-26	HA532743	CH Angle A	TW-0009	1
1-8	HZ532710	Tape Guide B	TW-0006	2	1-27	HR556582	REC./ERASE HEAD RE4-6		1
1-9	ZG466312	Angle Adjust Spring E	BS-0018	2	1-28x	HZ583176	RE4-6 Terminal Plate	TW-0035	1
1-10	ZW273835	Nut M3		4	1-29	ZS477876	Screw, pan head 2x3		2
1-11	MH529233	Head Base Prop B	ND-0017	2	1-30	MH625094	Relay Prop	MY-0005	2
1-12	ZW273914	Spring Washer M4		4	1-31	ZS369900	Screw, pan head 3x8,		
1-13	HZ532732	CH Retaining Base	TW-0008	1			w/washer		2
1-14	ZS608512	Screw, pan head 3x13		9	1-32	EA625138	Relay P.C. Board	MY-0008	1
1-15	ZG466312	Angle Adjust Spring E	BS-0018	6	1-33	EP621808	Relay MTS-2	47-2-26	1
1-16	HZ532765	PH Retaining Base	TW-0010	2	1-34x	ED624903	Silicon Diode IS2473	45-3-28	1
1-17	ZG303300	Angle Adjust Spring B	RD-55	3	1-35	ZS422076	Screw, pan head 3x5		2
1-18	HA625105	Head Angle A	MY-0006	1	1-36x	EA382713	Head Connector P.C. Board	RD-A8	1
1-19	HA625116	Head Angle B	MY-0006	1					

When ordering parts, Please describe Parts Number, Serial Number, and Model Number in detail.

2 ILLUSTRATION OF REEL MOTOR/REEL TABLE BLOCK

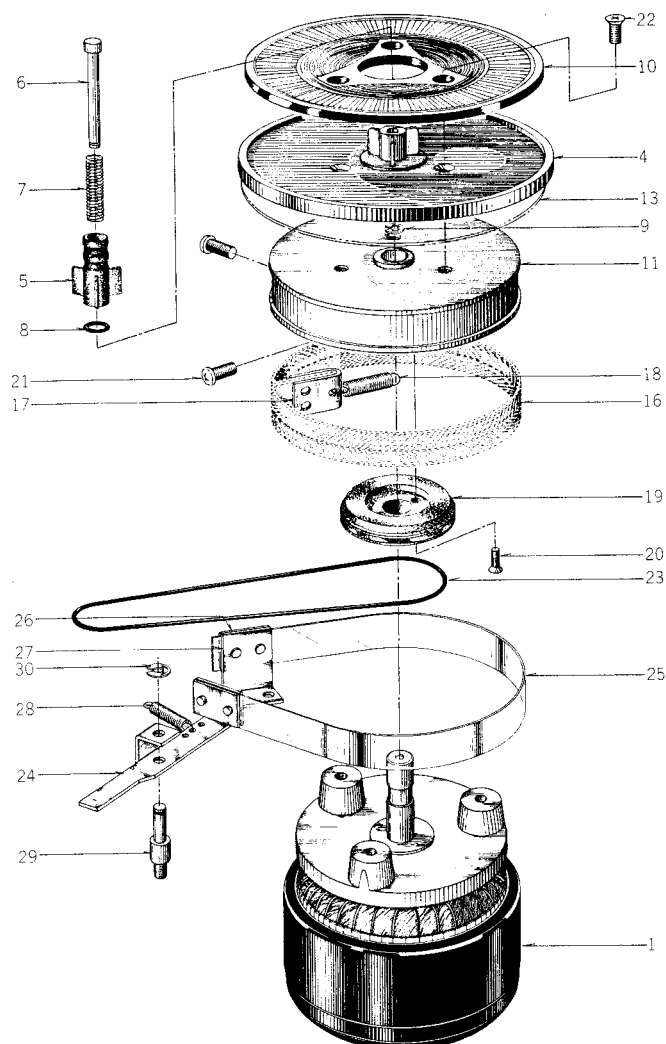

REEL MOTOR/REEL TABLE BLOCK

Ref. No.	Parts No.	Description	Schematic No.	Q'ty	Ref. No.	Parts No.	Description	Schematic No.	Q'ty
2-1	BM314741	Reel Motor (24XO-2) Block Comp.	ND,MC,KF,KH KD,MR,MS	1	2-17	MT317485	U Metal Fitting	MI- 218	1
2-2x	BR398430	Supply Reel Table Block Comp.	KD, KF	1	2-18	ZG317496	Felt Tension Spring	MI- 260	1
2-3x	BR398441	Take-up Reel Table Block Comp.	KD, KF	1	2-19	MR317507	Counter Pulley (Take-up)	MI- 217	1
2-4	MT488147	Reel Table Disk B, RD	RD-272	1	2-20	ZS516644	Screw, countersunk head 2.3x10		2
2-5	MT255420	Reel Retainer	3R-102	1	2-21	ZS424056	Screw, pan head 4x10		2
2-6	MS342000	Reel Shaft	3R-108	1	2-22	ZS403222	Screw, countersunk head 3x10		3
2-7	ZG255633	Reel Spring	3R-109	1	2-23	MB625566	Counter Belt D88.4x1.4	MI- 1046	1
2-8	MT297663	3R 'O' Ring 2.9x1.65M	3R-139	1	2-24	ML314976	Brake Lever A	MI- 210	1
2-9	ZW270088	'E' Ring 1.9M	6-1-9	1	2-25	MT314987	Brake Band	MI- 213	1
2-10	MT397225	Reel Table Rubber	KD-2017	1	2-26	MZ314998	Brake Band Retaining Plate	MI- 212	4
2-11	MT495606	Brake Drum (R) (Take-up)	MR-216	1	2-27	MZ315000	Brake Band Support	MI- 214	2
2-12x	MT495617	Brake Drum (L) A (Supply)	MR-216	1	2-28	ZG315011	Brake Lever Spring	MI- 116	2
2-13	MT405268	Reel Table Spacer	KD-2018	1	2-29	MH337373	Brake Lever Prop	MI- 102	1
2-14x	ZW273778	Earth Lug M3		2	2-30	ZW290283	'U' Ring 2.85M	6-1	1
2-15x	ZS425981	Screw, binding head 3x3		2					
2-16	MT436860	Brake Cloth Comp.	MR-269	1					

When ordering parts, Please describe Parts Number, Serial Number, and Model Number in detail.

3 ILLUSTRATION OF MAIN MOTOR BLOCK

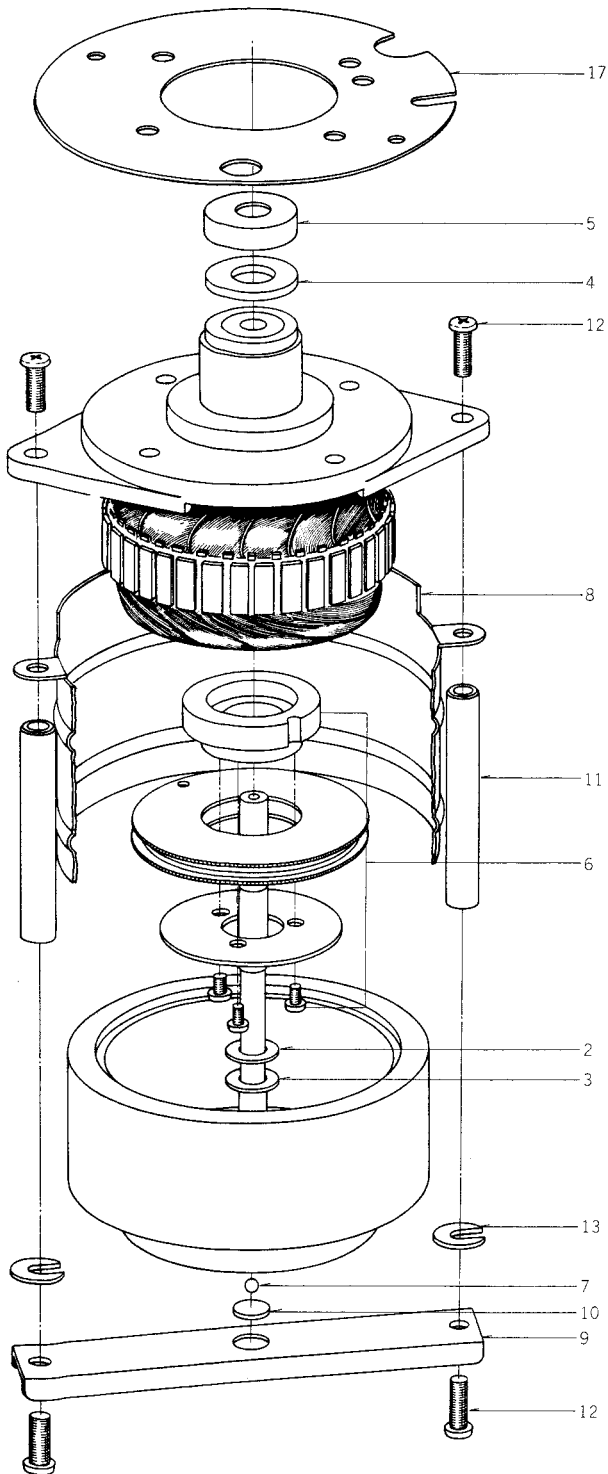

MAIN MOTOR BLOCK

Ref. No.	Parts No.	Description	Schematic No.	Q'ty
3-1x	BM600298	Main Motor Block Comp.	KJ, MY	1
3-2	ZW597543	Thrust Washer A	KJ-7009	1
3-3	ZW605698	Thrust Washer B	KJ-7009	1
3-4	ZW597622	Felt Washer	KJ-7022	1
3-5	SK597633	Cap	KJ-7023	1
3-6	BZ600300	Detector Gear Block Comp.	MY,TE,NE	1
3-7	MV368886	Steel Ball D3		1
3-8	MZ597666	Motor Shield Plate	KJ-7026	1
3-9	MZ597644	Thrust Angle	KJ-7024	1
3-10	MZ597690	Ball Holder	KJ-7029	1
3-11	MS597655	Thrust Holding Prop	KJ-7025	2
3-12	ZS413234	Screw, pan head 4x12		4
3-13	ZW603786	Adjust. Washer (U)		
		D4x13x0.2t		2
3-14x	ZW603797	Adjust. Washer (U)		
		D4x13x0.5t		2
3-15x	ZW603764	Adjust. Washer (U)		
		D4x13x1.2t		2
3-16x	ZW603775	Adjust. Washer (U)		
		D4x13x1.6t		2
3-17	MZ625577	Motor Shield Plate	MY-1047	1

When ordering parts, Please describe Parts Number, Serial Number, and Model Number in detail.

4 ILLUSTRATION OF IMPEDANCE ROLLER BLOCK

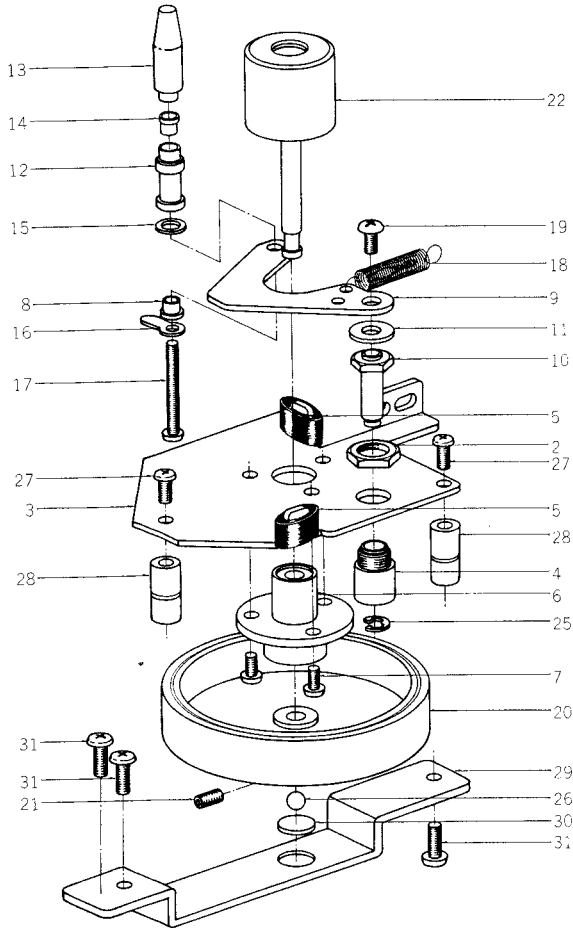

IMPEDANCE ROLLER BLOCK

Ref. No.	Parts No.	Description	Schematic No.	Q'ty
4-1x	BI657112	Impedance Roller Block		
		Comp.	MY	1
4-2	ZW603990	Metal Nut	6-39	1
4-3	MZ651881	Impedance Table	MY2065	1
4-4	MV597082	Sensing Shaft Metal	KJ:028	1
4-5	MZ606712	Stopper Rubber KJ	KJ:060	2
4-6	MZ597093	Metal Case, w/metal	KJ:029	1
4-7	ZS499331	Screw, pan head 2.3x5		3
4-8	EZ606701	Insulator Collar L	KJ:039	1
4-9	MZ597137	Sensing Arm	KJ:036	1
4-10	MS597148	Sensing Shaft	KJ:037	1
4-11	ZW604012	Washer D4.3x11x0.1t		3
4-12	MZ597172	Sensing Post (Lower)	KJ:040	1
4-13	MZ597150	Sensing Post (Upper)	KJ:038	1
4-14	SE597161	Insulated Collar	KJ:039	1
4-15	ZW601075	Washer D4.1x7x0.1t		1
4-16	ZW273633	Earth Lug M2.3		1
4-17	ZS484828	Screw, binding head 2.3x25		1
4-18	ZG646020	Z Arm Spring	MY2059	1
4-19	ZS201150	Screw, truss head 3x6 (Black)		1
4-20	MI651903	Flywheel	MY2066	1
4-21	ZS593796	Set Screw, hexagon Socket 3x6 (Flat/P.)		2
4-22	MR597115	Impedance Roller, w/shaft	KJ:033	1
4-23x	MZ597126	Roller Plate	KJ:035	1
4-24x	ZW649618	Washer (Teflon) D4x10x1t.		1
4-25	ZW270101	'E' Ring 3M	6-14	1
4-26	MV537862	Steel Ball D4		1
4-27	ZS422076	Screw, pan head 3x5		3
4-28	MH625162	Z Block Prop	MY2004	3
4-29	MZ596823	Thrust Plate	KJ:004	1
4-30	ZW593212	Washer D8x1t		1
4-31	ZS421806	Screw, pan head 3x8		3

When ordering parts, Please describe Parts Number, Serial Number, and Model Number in detail.

5 ILLUSTRATION OF PAUSE SW./TENSION ARM BLOCK

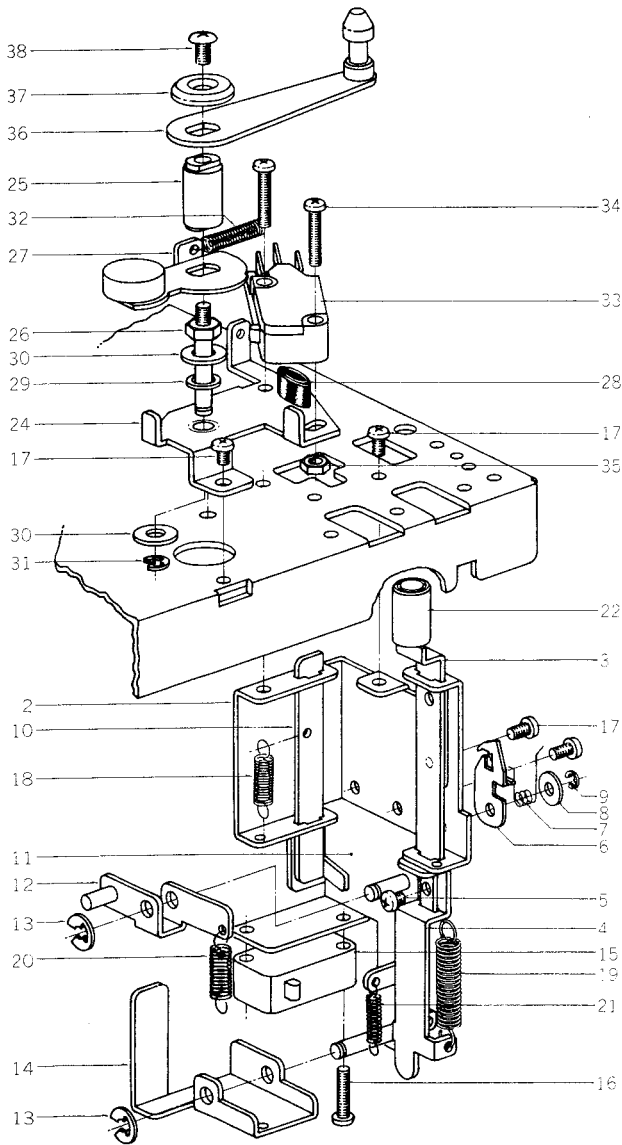

PAUSE SW./TENSION ARM BLOCK

Ref. No.	Parts No.	Description	Schematic No.	Qty
PAUSE SW. BLOCK				
5-1x	BZ624813	Pause SW. Block Comp.	MY-11	1
5-2	MZ631001	Pause Lever Bracket, w/shaft	MY-2214	1
5-3	ML630955	Pause Button Lever A, w/pin C	MY-2209	1
5-4	ML630966	Pause Button Lever B	MY-2210	1
5-5	ZS432674	Screw, pan head 3x3		1
5-6	TC515575	SW. Lock Cam B	CG-2301	1
5-7	ZG632553	Button Lock Spring C	CG-2303	1
5-8	ZW452373	Washer (SPC) D3x8x0.5t		1
5-9	ZW270088	'E' Ring 1.9M	6-1-9	1
5-10	ML630990	Lock Lever	MY-2213	1
5-11	MZ631012	Switch Bracket, w/pin	MY-2215	1
5-12	ML630977	Pause Lever, w/pin	MY-2211	1
5-13	ZW290283	'U' Ring 2.85M	6-1-1	2
5-14	ML630988	SW. Lever	MY-2212	1
5-15	ES249974	Micro SW. M-8-3 U/L	25-1-4	1
5-16	ZS483502	Screw, pan head 3x13		2
5-17	ZS422076	Screw, pan head 3x5		5
5-18	ZG394378	Return Spring	CS-2106	1
5-19	ZG314706	Spring IB	MR-115	1
5-20	ZG316833	DS Spring	MR-257	1
5-21	ZG371114	Reset Lever Spring	ED-219	1
5-22	SK631282	Push Button Knob H	91-5051	1
TENSION ARM BLOCK				
5-23x	BZ622618	Tension Arm Block Comp.	MY	1
5-24	MZ625803	Tension Arm Table, w/metal	MY-2022	1
5-25	MA625825	Tension Shaft A	MY-2024	1
5-26	MS615014	Tension Shaft B	MY-2032	1
5-27	MZ627265	Tension SW. Cam, w/counter weight	MY-2025	1
5-28	MZ810191	Cushion Rubber, RD	RD-278	1
5-29	ZW601075	Washer D4.1x7x0.1t		1
5-30	ZW419646	Washer (SPC) D4.5x9.8x0.5t		2
5-31	ZW270101	'E' Ring 3M	6-1-9	1
5-32	ZG614970	Tension Spring	MY-2026	1
5-33	ES562465	Micro SW. K-1	25-1-26	1
5-34	ZS422965	Screw, pan head 3x15		2
5-35	ZW273756	Nut M3		1
5-36	ML580465	Tension Arm, w/guide B	TD-2039	1
5-37	ZW535094	Decorative Washer	TE-2077	1
5-38	ZS200395	Screw, countersunk head 3x6		1
5-39	ZS422076	Screw, pan head 3x5		2

When ordering parts, Please describe Parts Number, Serial Number, and Model Number in detail.

6 ILLUSTRATION OF PINCH ROLLER PLUNGER BLOCK

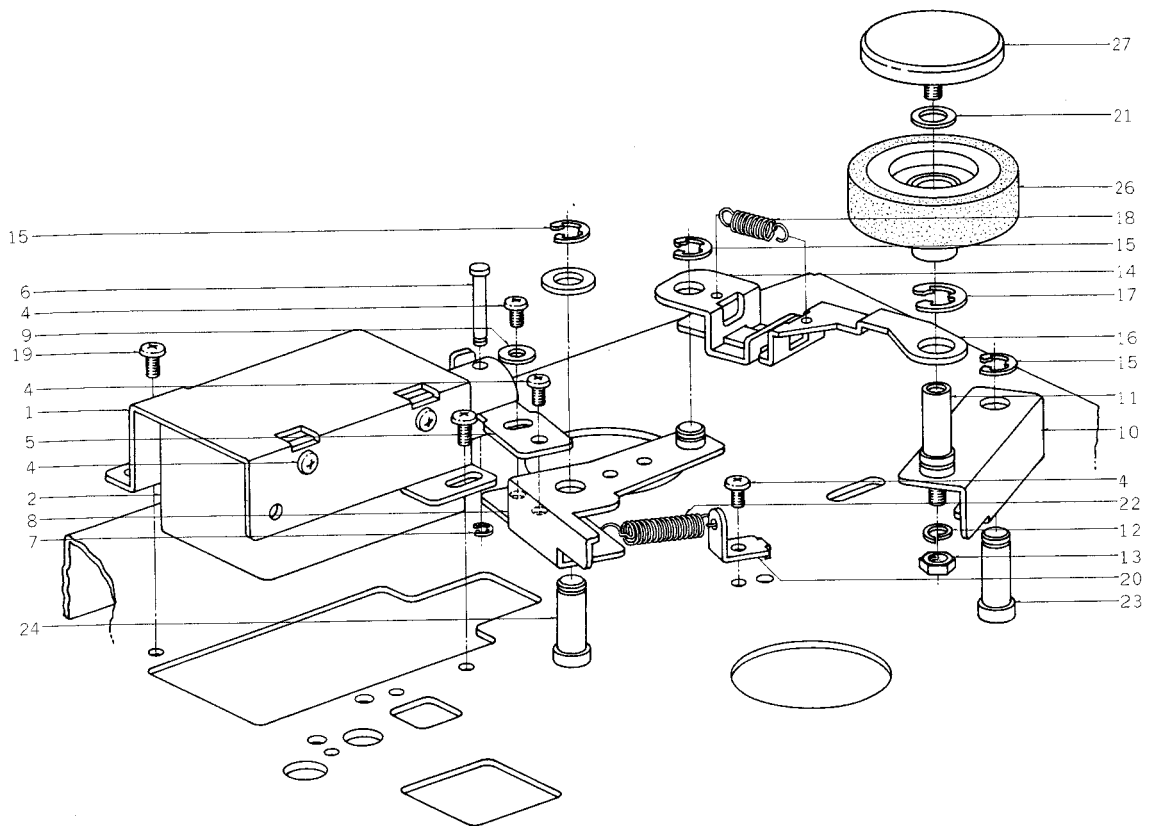

PINCH ROLLER PLUNGER BLOCK

Ref. No.	Parts No.	Description	Schematic No.	Q'ty
6-1	MZ625768	Plunger Bracket	MY2018	1
6-2	EP573658	Plunger Solenoid 1660THT-3	44-166	1
6-3x	ED224550	Silicon Diode 10D4	45-16	1
6-4	ZS422076	Screw, pan head 3x5		4
6-5	MZ625770	Plunger Plate	MY2019	1
6-6	MH533913	Connecting Pin	TW2010	1
6-7	ZW270088	'E' Ring 1.9M	6-14	2
6-8	ML627254	Plunger Lever B, w/pin	MY2205	1
6-9	ZW555693	Washer D3.2x8x0.5t		1
6-10	MZ625421	Pinch Roller Arm	MY1032	1
6-11	MS625432	Pinch Roller Shaft	MY1033	1
6-12	ZW273914	Spring Washer M4		1
6-13	ZW416693	Nut M4		1
6-14	MZ625443	Pinch Roller Plate A	MY1034	1
6-15	ZW270134	'E' Ring 5M	6-14	3
6-16	MZ625454	Pinch Roller Plate B	MY1035	1
6-17	ZW334653	'E' Ring 7M	6-14	1
6-18	ZG625465	Pinch Roller Spring	MY1036	1
6-19	ZS379350	ISO Screw, pan head 3x6		1
6-20	MZ582030	Spring Hanger	TD1018	1
6-21	ZW260010	Washer (PBP) D6.1x10x0.1t		1
6-22	ZG580768	Spoke Spring	TD1077	1
6-23	MS625184	Pinch Roller Arm Shaft	MY1006	2
6-24x	ZW416698	Nut M4		2
6-25x	ZW273914	Spring Washer M4		1
6-26	MP625048	Pinch Roller H, LC-321		1
6-27	SK631326	Pinch Roller Cap C	MS1020	1

When ordering parts, Please describe Parts Number, Serial Number, and Model Number in detail.

7 ILLUSTRATION OF OPERATION BLOCK

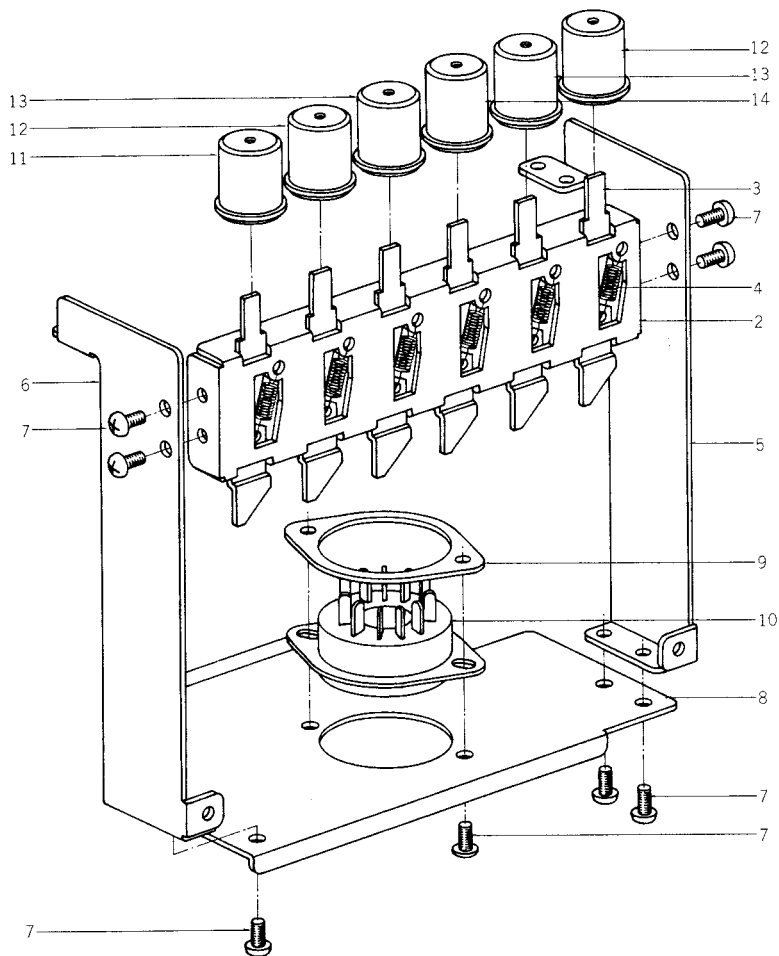

OPERATION BLOCK

Ref. No.	Parts No.	Description	Schematic No.	Q'ty
7-1 x	BZ624780	Operation Block Comp.	MY-II	1
7-2	MZ630876	Lever Bracket	MY-2201	1
7-3	ML630887	Operation Lever	MY-2202	6
7-4	ZG456120	Setting Lever Spring	CS-1187	6
7-5	MZ630898	Operation Side Plate A (Right)	MY-2203	1
7-6	MZ630900	Operation Side Plate B (Left)	MY-2203	1
7-7	ZS325495	Tapping Screw #2 3x6		8
7-8	MZ630911	Remo-Con Plate	MY-2204	1
7-9	MZ302400	Remote Control Socket		
		Mt. Plate	PX-515	1
7-10	EJ222748	Socket, Sub Magnale #311 SG	31-1-39	1
7-11	SB631135	Push Button C (Red)	CW-2014	1
7-12	SB631146	Push Button D (Yellow)	CW-2014	2
7-13	SB631157	Push Button E (Green)	CW-2014	2
7-14	SB631168	Push Button F (White)	CW-2014	1

When ordering parts, Please describe Parts Number, Serial Number, and Model Number in detail.

8 ILLUSTRATION OF MECH. ASSEMBLY BLOCK

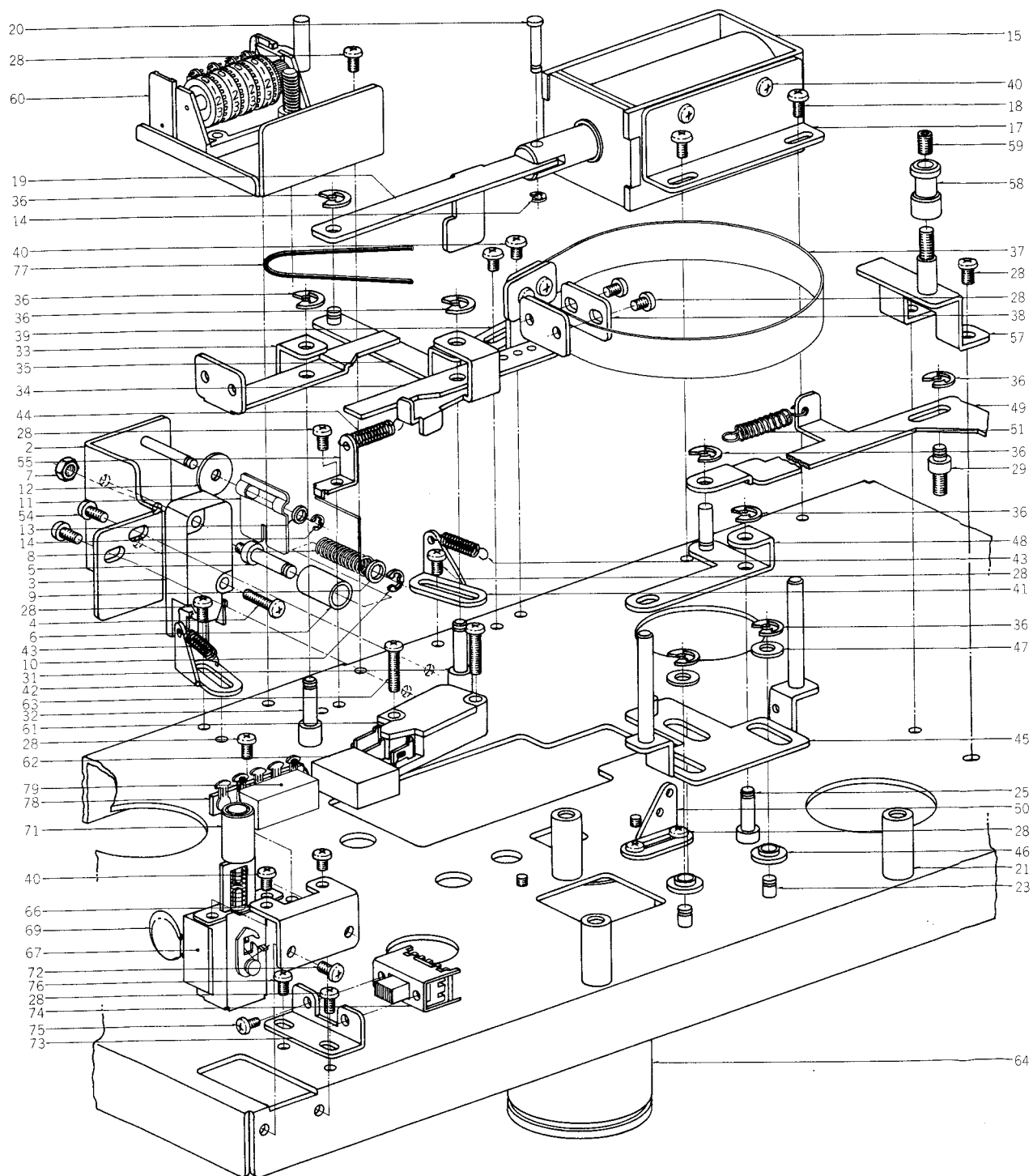

MECH. ASSEMBLY BLOCK

Ref. No.	Parts No.	Description	Schematic No.	Q'ty	Ref. No.	Parts No.	Description	Schematic No.	Q'ty
QUICK SW. BLOCK					8-66	EZ625544	Power SW. Table	MY-1044	1
8-1x	BS622631	Quick SW. Block Comp.	MY-II	1	8-67	ES479395	Push SW. TV-3 JH5	25-5-62	1
8-2	MZ630944	Micro SW. Table, w/Prop	MY-2208	1	8-68x	ES621178	Push SW. S-J4162 (CEE)	25-5-145	1
8-3	ES573478	Micro SW. K-3	25-1-31	1	8-69	EC551160	Ceramic/C. NB821 YZ 0.01μF(Z) 1.4KWV	24-5-55	2
8-4	ZS483502	Screw, pan head 3x13		2	8-70x	EC565896	Ceramic/C. DP6600YM 0.01μF(P) 1.4KWV (CSA, JPN)	24-5-58	1
8-5	MH528513	SW. Pin	ND-1055	1	8-71	SK631304	Push Button Knob I	91-5051	1
8-6	MH527635	SW. Pipe	ND-1054	1	8-72	ZS325495	Tapping Screw #2 3x6		2
8-7	ZW273756	Nut M3		1	8-73	MZ625555	Speed SW. Table	MY-1045	1
8-8	ZG529211	SW. Spring	ND-1053	1	8-74	ES621898	Slide SW. SSC342B	25-3-109	1
8-9	ZW259738	Washer (Polyslider) D4.1x7x0.25t		1	8-75	ZS432843	Screw, pan head 2.6x4		2
8-10	ZW270101	'E' Ring 3M	6-1-9	1	8-76	ZS432674	Screw, pan head 3x3		1
8-11	MZ529391	Quick Plate	ND-1063	1	8-77	MB625566	Counter Belt	MY-1046	1
8-12	ZW622001	Washer D3.1x13x0.5t		1	8-78	EJ255115	Lug Plate VB2L2	33-4-3	1
8-13	ZW622012	Washer D3.1x5x0.2t		1	8-79	ER554556	Cement/R. 5W 39Ω(K) (Wire-wound Type)	35-16-3	1
8-14	ZW270088	'E' Ring 1.9M	6-1-9	2					
BRAKE PLUNGER BLOCK									
8-15	EP650081	Plunger Solenoid SDC-1064	44-1-75	1					
8-16x	ED224550	Silicon Diode 10D4	45-2-16	1					
8-17	MZ630933	Plunger Bracket B	MY-2207	1					
8-18	ZS422076	Screw, pan head 3x5		2					
8-19	MZ630922	Plunger Joint	MY-2206	1					
8-20	MH257477	Connecting Pin	RD-211	1					
MECH. ASSEMBLY BLOCK									
8-21	MH625140	Head Base Prop	MY-1002	3					
8-22x	ZS413201	Screw, pan head 4x8		3					
8-23	MH581927	Shifter Guide Post	TD-1006	3					
8-24x	ZW273756	Nut M3		3					
8-25	MZ625151	Shifter Lever Post	MY-1003	1					
8-26x	ZW416693	Nut M4		1					
8-27	MH625162	Z Block Prop	MY-1004	3					
8-28	ZS422076	Screw, pan head 3x5		45					
8-29	MZ627210	Joint Lever Post	MY-1203	1					
8-30x	ZW416698	Nut M4		3					
8-31	MH625195	Brake Lever Prop	MY-1007	1					
8-32	MH337373	Brake Lever Prop	MR-102	1					
8-33	ML396810	Brake Lever B	KD-1038	1					
8-34	ML314976	Brake Lever A	MR-210	1					
8-35	ML627232	Brake Lever D, w/pin	MY-1205	1					
8-36	ZW290283	'U' Ring 2.85M	6-1-1	9					
8-37	MT314987	Brake Band	MR-213	2					
8-38	MZ314998	Brake Band Retaining Plate	MR-212	4					
8-39	MZ315000	Brake Band Support	MR-214	2					
8-40	ZS417216	Screw, pan head 3x4		6					
8-41	MZ397080	Spring Rack	KD-1010	1					
8-42	MZ314605	Spring Rack, MR	MR-104	1					
8-43	ZG315011	Brake Lever Spring	MR-116	2					
8-44	ZG371114	Reset Lever Spring	ED-219	1					
8-45	MZ625342	Shifter Plate, w/pin	MY-1024	1					
8-46	ZW580173	Guide Washer	TD-1055	3					
8-47	ZW420682	Washer (Nylon) D4.2x9x0.5t		3					
8-48	ML627197	Shifter Lever B, w/pin	MY-1201	1					
8-49	ML627221	Joint Lever	MY-1204	1					
8-50	MZ314605	Spring Rack, MR	MR-104	1					
8-51	ZG625375	Play Spring	MY-1027	1					
8-52x	ZW621876	Washer D6.2x13x1t		1					
8-53x	ZW270134	'E' Ring 5M	6-1-9	2					
8-54	ZS608321	Screw, pan head 3x6, w/washer		2					
8-55	MZ582030	Spring Hanger	TD-1018	1					
8-56x	ZG580768	Spoke Spring	TD-2077	1					
8-57	MZ625511	Reverse Guide Table	MY-1041	1					
8-58	HZ315090	Reverse Guide	RD-225	1					
8-59	ZS344463	Set Screw, hexagon socket 4x6 (cup/p.)		1					
8-60	MC621887	Counter MP-490-21	9-1-38	1					
8-61	ES573456	Micro SW. K-2	25-1-30	1					
8-62	ER376435	Spark Quencher U/L 0.1μ+120Ω 250WV	41-1-35	1					
8-63	ZS483502	Screw, pan head 3x13		2					
8-64	EC520626	MP/C. (3+1)μFx2 250WV AC (Lug Type UNI/D.)	24-9-74	1					
8-65x	EC536927	MP/C. 3μFx2 250WV AC (Lug Type UNI/D.)	24-9-79	1					

When ordering parts, Please describe Parts Number, Serial Number, and Model Number in detail.

9 ILLUSTRATION OF POWER SUPPLY BLOCK

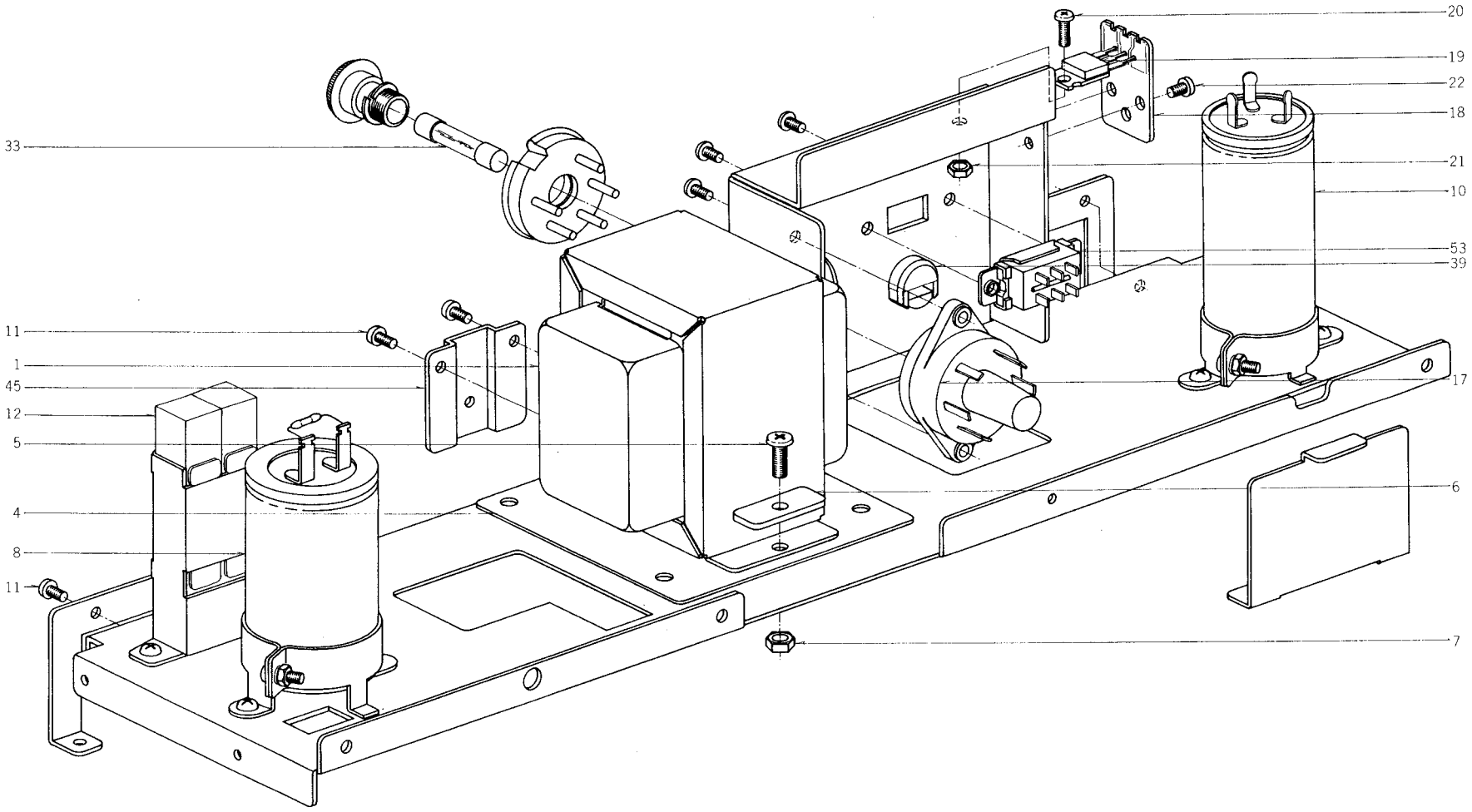

POWER SUPPLY BLOCK

Ref. No.	Parts No.	Description	Schematic No.	Q'ty
9-1	BT621922	Power Trans. MYT-1	38-4-314	1
9-2x	BT621988	Power Trans. MYT-11 (JPN, CSA)	38-4-316	1
9-3x	BT621990	Power Trans. MYT-12 (CEE)	38-4-317	1
9-4	MZ627636	Trans. Shield Plate	MY-2053	1
9-5	ZS424056	Screw, pan head 4x10		2
9-6	EZ486617	Trans. Reinforcement Plate B	LF-5222	2
9-7	ZW413188	Nut M4		2
9-8	EC364858	Elect./C. 330μF 160WV (Lug Type)	24-10-56	1
9-9x	ER365016	Carbon/R. RD1/4 220k(J) (Insu. Type)	35-9-5	1
9-10	EC593763	MP/C. 3.5+1.5μF 150WV AC (Lug Type UNI/D.)	24-9-88	1
9-11	ZS325495	Tapping Screw #2 3x6		15
9-12	ER575640	Cement/R. H(20+20)B (43+220+180)K	35-16-54	1
9-13x	EZ624047	Cord Retainer	2-7-48	4
9-14x	MZ626861	VS Table A	MY-2030	1
9-15x	MZ625858	VS Table B (CSA, CEE)	MY-2030	1
9-16x	MZ647133	VS Base C (JPN)	MY-2030	1
9-17	EJ233370	Socket (Volt. Selector) S-18010	40-2-3	1
9-18	EA628075	Transistor P.C. Board	MY-2054	1
9-19	ET621786	Transistor T1P-48	45-1-197	1
9-20	ZS421806	Screw, pan head 3x8		1
9-21	ZW273756	Nut M3		1
9-22	ZS422076	Screw, pan head 3x5		2
9-23x	EA624521	Fuse P.C. Board MY-1(A) (JPN, CSA)	33-2-46	1
9-24x	EA624532	Fuse P.C. Board MY-1(B) (JPN, CSA)	33-2-47	1
9-25x	EA624554	Fuse P.C. Board MY-2(A) (CEE)	33-2-48	1
9-26x	EA624565	Fuse P.C. Board MY-2(B) (CEE)	33-2-49	1
9-27x	EA615093	Fuse P.C. Board MY-1 (JPN, CSA)	MY-2045	1
9-28x	EA614632	Fuse P.C. Board MY-2 (JPN, CSA)	MY-2046	1
9-29x	ZS462925	Tapping Screw #2 4x8 (BR)		4
9-30x	EZ614586	Fuse Table MY (CSA, CEE, JPN)	MY-2043	2
9-31x	ZS279350	ISO Screw, pan head 3x6		4
9-32x	ZS455207	Tapping Screw #2 3x5 (BR)		4
9-33	EF563703	Fuse 2A 250V	39-1-50	1
9-34x	EF563681	Fuse 1A 250V (JPN)	39-1-50	4
9-35x	EF511637	Fuse ULMF61M 250V 1A (CSA)	39-1-45	4
9-36x	EF602550	Fuse 1.25AT 250V (CEE)	39-1-53	1
9-37x	EF601942	Fuse 630MAT (SEMKO)	39-1-53	1
9-38x	EF624543	Fuse ULMF61M 250V 2A (CSA)	39-1-45	2
9-39	EJ631945	Strain Relief SR-4N-4	2-7-49	1
9-40x	EW374894	U/L AC cord 3M	26-3-19	1
9-41x	EW524845	AC Cord 2.5M (JPN)	26-3-31	1
9-42x	EW516600	Power Cord VM-0065 (CEE)	26-3-28	1
9-43x	EW604585	Power Cord BSI	26-3-37	1
9-44x	EJ205986	Cramp Terminal 2-SD	32-1-8	2
9-45	MZ629414	Reinforcement Bracket	MY-2055	1
9-46x	MZ259233	Wire Band C	3A-745	1
9-47x	ZW273881	Earth Lug M4 (CEE)		1
9-48x	ZW273892	Toothed Lock Washer M4 (CEE)		1
9-49x	ZS413201	Screw, pan head 4x8 (CEE)		1
9-50x	ZW416693	Nut M4 (CEE)		1
9-51x	EJ300508	Mate-N-Lock Plug Housing 9P 1-480274-0	52-1-7	1
9-52x	EJ373634	Socket Contact 61115-1	52-1-1	7
9-53	ES479485	Slide SW. S-1	25-3-66	1
9-54x	ZS414178	Screw, truss head 3x5, w/washer		2
9-55x	SM647245	Cycle Name Plate	MY-2058	1

10 POWER SUPPLY P.C. BOARD (MY-2222) BLOCK

Symbol No.	Parts No.	Description	Q'ty
10-1	BA624802	Power Supply P.C. Board Comp. (MY-2222)	1
10-TR1	ET511920	Transistor 2SC1247A (B) (V)	1
10-TR2	ET398711	Transistor 2SC945 (Q) (R)	1
10-TR3	ET537300	Transistor 2SD361 (D) (E)	1
10-D1to4	ED494583	Silicon Diode 10D05	4
10-D5	ED357794	Zener Diode RD-5A(M)	1
10-D6to8	ED624903	Silicon Diode IS2473	3
10-D9to13	ED224550	Silicon Diode 10D4	5
10-RL1,2	EP638763	Relay MY4-O-US DC24V	2
10-RL3	EP616500	Relay LC1-C-JT DC24V	1
10-CR1to7	ER376435	Spark Quencher U/L 0.1μ+120Ω 250WV	7
10-VR1	EV554670	Semi-fixed/Vol. V10K8-1-5 1kB	1
10-2	EZ626894	Heat-sink Plate B	1
10-3	ZS421806	Screw, pan head 3x8	1
10-4	ZW273756	Nut M3	1
10-5	ZS422076	Screw, pan head 3x5	2
10-6	EZ615058	P.C. Board Holder A	1
10-7	ZS325495	Tapping Screw #2 3x6	2
Capacitor, Vertical Type			
10-C1	EC564952	Elect. 470μF 50WV	1
10-C2	EC372148	Elect. 220μF 35WV	1
10-C3	EC250885	Mylar 0.01μF (K) 50WV	1
10-C4	EC313121	Elect. 220μF 25WV	1
10-C5,6	EC462611	MP/C. 0.47μF (K) 250WV (Tub. Type)	2

Carbon Resistor Omitted

11 SYS. CON. P.C. BOARD (MY-2221) BLOCK

Symbol No.	Parts No.	Description	Q'ty
11-1	BA624791	Sys. Con. P.C. Board Comp. (MY-2221)	1
11-TR1to9	ET398711	Transistor 2SC945 (Q) (R)	11
11-TR10	ET511694	Transistor 2SC1211 (D) (E)	1
11-TR11,12	ET398711	Transistor 2SC945 (Q) (R)	2
11-D1	ED624903	Silicon Diode IS2473	1
11-D2to7	ED560913	Silicon Diode IS2473 VE	6
11-D8	ED624903	Silicon Diode IS2473	1
11-D9to14	ED560913	Silicon Diode IS2473 VE	5
11-D15to33	ED624903	Silicon Diode IS2473	18
11-D34,35	ED560913	Silicon Diode IS2473 VE	2
11-RL1	EP621808	Relay MTS-2	1
11-P11	EZ624071	Pin for V Connector, w/base RTB-1, 5-6	1
11-2	ZS609298	Screw, flat fillister head 3x6	6
11-3	ZW273756	Nut M3	6
11-4	ZW273802	Toothed Lock Washer M3	6
Capacitor, Vertical Type			
11-C1	EC450055	Elect. 1μF 25WV	1
11-C2	EC320051	Elect. 10μF 16WV	1
11-C3to5	EC450055	Elect. 1μF 25WV	3
11-C6	EC220994	Elect. 10μF 25WV	1
11-C7	EC220127	Elect. 100μF 16WV	1
11-C8	EC331328	Elect. 3.3μF 25WV	1
11-C9to11	EC456041	Elect. 33μF 25WV	3

Carbon Resistor Omitted

12 SERVO P.C. BOARD (MY-2036) BLOCK

Symbol No.	Parts No.	Description	Q'ty
12-1	BA622574	Servo P.C. Board Comp. (MY-2036)	1
12-TR1,2	ET478001	Transistor 2SC945 (P) (Q)	3
12-TR3,4	ET399846	Transistor 2SC945 (Q)	2
12-TR5	ET538154	Transistor 2SA564 (Q) (R)	1
12-TR6	ET399846	Transistor 2SC945 (Q)	1
12-TR7	ET623867	Transistor 2SD361 (D1) (D2)	1
12-TR8	ET478001	Transistor 2SC945 (P) (Q)	1
12-D1	ED557447	Silicon Diode 1S1588	1
12-D2to5	ED224548	Silicon Diode 10D2	4
12-TH1	ED593357	Thermister 34D21	1
12-VR1	EV621955	Semi-fixed/Vol. V10K8-1-5 B10K	1
12-VR2	EV621966	Semi-fixed/Vol. V10K8-1-5 B30K	1
12-2	ZS421806	Screw, pan head 3x8	1
12-3	ZW273756	Nut M3	1
12-4	EZ615047	Heat-sink Plate A	1
12-5	ZS422076	Screw, pan head 3x5	6
12-6	EZ615060	P.C. Board Holder B	1
12-7	EZ615071	P.C. Board Holder C	1
12-R20	ER593346	Cement/R. 2W 330Ω (K)	1

Capacitor, Vertical Type

12-C1	EC251291	Mylar 0.1μF (K) 50WV	1
12-C2	EC251122	Mylar 0.027μF (K) 50WV	1
12-C3	EC250582	Mylar 0.0033μF (K) 50WV	1
12-C4	EC331828	Elect. 3.3μF 25WV	1
12-C5	EC251122	Mylar 0.027μF (K) 50WV	1
12-C6	EC250582	Mylar 0.0033μF (K) 50WV	1
12-C7	EC487157	NP/C. 0.47μF (M) 50WV	1
12-C8	EC557166	Solid Aluminum 3.3μF 25WV	1
12-C9	EC450055	Elect. 1μF 25WV	1
12-C10	EC320051	Elect. 10μF 16WV	1
12-C11	EC220151	Elect. 100μF 25WV	1
12-C12	EC250885	Mylar 0.01μF (K) 50WV	1
12-C13	EC346735	Elect. 47μF 50WV	1

Carbon Resistor Omitted

13 PEAK LEVEL P.C. BOARD (MY-5202) BLOCK

Symbol No.	Parts No.	Description	Q'ty
13-1	BA624835	Peak Level P.C. Board Comp. (MY-5202)	1
13-TR1to4	ET398711	Transistor 2SC945 (Q) (R)	4
13-D1,2	ED560913	Silicon Diode 1S2473 VE	2
13-D3	ED591333	Luminous Diode GL-31AR	1
13-VR1,2	EV520806	Semi-fixed/Vol. V8K4-1 10 kB	2
13-2	MZ631045	Peak Level Table	1
13-3	EZ631080	Diode Bracket	1
13-4	ZS325495	Tapping Screw #2 3x6	2

Capacitor, Vertical Type

13-C1	EC368256	Elect. 0.47μF 25WV	1
13-C2	EC220994	Elect. 10μF 25WV	1
13-C3	EC450527	Elect. 4.7μF 25WV	1
13-C4	EC350875	Mylar 0.001μF (J) 50WV	1
13-C5	EC368256	Elect. 0.47μF 25WV	1
13-C6	EC220994	Elect. 10μF 25WV	1
13-C7	EC340527	Elect. 4.7μF 25WV	1
13-C8	EC350875	Mylar 0.001μF (J) 50WV	1
13-C9	EC331828	Elect. 3.3μF 25WV	1
13-C10	EC220678	Elect. 47μF 25WV	1

Carbon Resistor Omitted

14 EQ. P.C. BOARD (MY-5014A) BLOCK

Symbol No.	Parts No.	Description	Q'ty
14-1	BA622710	EQ. P.C. Board Comp. (MY-5014A)	1
14-SW1	ES622023	Lever SW. J-L6004	1
14-SW2	ES622034	Lever SW. J-L7003	1
14-L1	EO369178	Ferri Inductor FL7H 1.5 MH (J)	2
14-L2	EO380564	Ferri Inductor FL7H 1.8 MH (J)	2
Capacitor, Vertical Type			
14-C1	EC329861	Mylar 0.027μF (J) 50WV	2
14-C2	EC368335	Mylar 0.022μF (J) 50WV	2
14-C3	EC379214	Mylar 0.047μF (J) 50WV	2
14-C4	EC379192	Mylar 0.039μF (J) 50WV	2

Carbon Resistor Omitted

15 PB. P.C. BOARD (MY-5017) BLOCK

Symbol No.	Parts No.	Description	Q'ty
15-1	BA622732	PB. P.C. Board Comp. (MY-5017)	1
15-TR1to4	ET234854	Transistor 2SC458LG (C)	8
15-TR5,6	ET478001	Transistor 2SC945 (P) (Q)	4
15-D1	ED570475	Zener Diode WZ-075	2
15-D2	ED219464	Germanium Diode 1N34A	2
15-L1	EO496361	Inductor 6070GE 23MH (J)	2
15-T1	BT517274	Headphone Trans. N16-53S	2
15-VR1	EV464220	Semi-fixed/Vol. V8K4-1 50 kB	2
15-VR2	EV622056	Co-axial 2-throw Vol. V24L5GPHN B10Kx2	1
15-VR3	EV464196	Semi-fixed/Vol. V8K4-1 2kB	2

Capacitor, Vertical Type

15-C1	EC220678	Elect. 47μF 25WV	2
15-C2	EC432810	Elect. 10μF 16WV NL	2
15-C3	EC290520	VFM 100PF (J) 50WV	2
15-C4	EC467133	VFM 68PF (J) 50WV	2
15-C5	EC290520	VFM 100PF (J) 50WV	2
15-C6	EC329771	Elect. 47μF 6.3WV	2
15-C7	EC320051	Elect. 10μF 16WV	2
15-C8	EC389485	Mylar 0.018μF (J) 50WV	2
15-C9,10	EC250683	Mylar 0.0022μF (J) 50WV	4
15-C11	EC220678	Elect. 47μF 25WV	2
15-C12	EC329850	VFM 220PF (J) 50WV	2
15-C13	EC432810	Elect. 10μF 16WV NL	2
15-C14	EC329771	Elect. 47μF 6.3WV	2
15-C15	EC399565	VFM 22PF (J) 50WV	2
15-C16	EC290520	VFM 100PF (J) 50WV	2
15-C17	EC320051	Elect. 10μF 16WV	2
15-C18	EC220364	Elect. 100μF 6.3WV	2
15-C19	EC450055	Elect. 1μF 25WV	2
15-C20	EC320051	Elect. 10μF 16WV	2
15-C21	EC450527	Elect. 4.7μF 25WV	2
15-C22	EC329771	Elect. 47μF 6.3WV	2

Carbon Resistor Omitted

16 REC., OSC. P.C. BOARD (MY-5016)

BLOCK

Symbol No.	Parts No.	Description	Q'ty
16-1	BA622721	Rec., Osc. P.C. Board Comp. (MY-5016)	1
16-TR1to4	ET234854	Transistor 2SC458LG (C)	8
16-TR5,6,7	ET478001	Transistor 2SC945 (P) (Q)	4
16-L1	EO321254	Ferri Inductor FL7H 5.6MH (J)	2
16-L2	EO333365	Osc. Coil OT-204	1
16-VR1	EV622078	Double Vol. V24L5DPHN A50Kx2	2
16-VR2	EV522797	Semi-fixed/Vol. V8K4-1 20 kB	2
16-R39	ER515070	Metal Oxide Film/R. 2W 150Ω (K)	1
16-R40	ER426892	Solid/R. RC1/2 2.4k (J)	1
Capacitor, Vertical Type			
16-C1	EC290520	VFM 100PF (J) 50WV	2
16-C2	EC220678	Elect. 47μF 25WV	2
16-C3	EC432810	Elect. 10μF 16WV NL	2
16-C4	EC290520	VFM 100PF (J) 50WV	2
16-C5	EC220364	Elect. 100μF 6.3WV	2
16-C6,7	EC399565	VFM 22PF (J) 50WV	4
16-C8	EC320051	Elect. 10μF 16WV	2
16-C9	EC329771	Elect. 47μF 6.3WV	2
16-C10	EC377212	VFM 47PF (J) 50WV	2
16-C11	EC320051	Elect. 10μF 16WV	2
16-C12	EC220678	Elect. 47μF 25WV	2
16-C13	EC329771	Elect. 47μF 6.3WV	2
16-C14	EC399565	VFM 22PF (J) 50WV	2
16-C15	EC290520	VFM 100PF (J) 50WV	2
16-C16	EC379170	Mylar 0.1μF (J) 50WV	2
16-C17	EC320051	Elect. 10μF 16WV	2
16-C18	EC329771	Elect. 47μF 6.3WV	2
16-C19	EC389496	Mylar 0.068μF (J) 50WV	2
16-C20	EC220151	Elect. 100μF 25WV	2
16-C21	EC320051	Elect. 10μF 16WV	2
16-C22	EC220994	Elect. 10μF 25WV	2
16-C23	EC405898	Styrol 470PF (J) 50WV	2
16-C24	EC250841	Mylar 0.01μF (J) 50WV	2
16-C25	EC558202	Trimmer TM-80A 80PF	2
16-C26	EC558235	Styrol 1800PF (J) 250WV	1
16-C27,28	EC250841	Mylar 0.01μF (J) 50WV	2
16-C29	EC450055	Elect. 1μF 25WV	1

Carbon Resistor Omitted

AMP. ASSEMBLY BLOCK

Ref. No.	Parts No.	Description	Schematic No.	Q'ty
FRONT CHASSIS BLOCK				
17-1	TA627028	Front Chassis A	MY-5001	1
17-2	EZ615115	P.C. Board Support	MY-5004	1
17-3	ZS325495	Tapping Screw #2 3x6		32
17-4	SZ615137	Panel Support	MY-5008	2
17-5	ML615126	Connecting Lever	MY-5005	1
17-6	ZW625241	Graduated Washer	MY-1013	2
17-7	ZS447840	Tapping Screw #2 3x8 (BR)		2
17-8	SZ615148	Amp. Support	MY-5009	1
17-9	ES621977	Lever SW. J-L6005	25-12-19	1
17-10	ZS422076	Screw, pan head 3x5		6
17-11x	EJ641441	6P Connector Assy.	MY-5206	1
17-12	EM573748	VU Meter KL-280B-28C (Yellow)	46-1-86	2
17-13	SZ631091	Meter Cushion B	MY-6203	1
17-14	ZG580533	Cramp Spring	TD-2046	4
17-15	ZW273756	Nut M3		4
17-16	EZ586326	Lamp Holder	LF-5324	1
17-17	EL593662	Cord Lamp 5.5V 60MA (220MMx2)	28-2-37	1
17-18	MZ627287	Jack Bracket	MY-5019	1
17-19	EJ592435	Mic. Jack 2PMJ4	31-2-44	2
17-20	EZ225180	Nylon Collar, Jack	LD-520	2
17-21	EZ225101	Jack Fiber D9.1x15.4x0.5t	DX-510	2
17-22	ZW554624	E Jack Nut	7-1-56	3
17-23	EJ255115	Lug Plate VB2L2	33-4-3	1
17-24	EC220768	Elect. 470μF 10WV	24-12-9	1
17-25x	ED494583	Silicon Diode 10D05	45-2-42	1
17-26	EJ601481	Mic. Jack 3PMJ4	31-2-45	1
17-27x	ZW436026	Washer (SPC) D9.2x15x0.5t		1
REAR CHASSIS BLOCK				
17-28	MZ627030	Rear Chassis	MY-5002	1
17-29	EJ364915	Multi-Jack 10P PB01-10S-24E2G	31-4-15	1
17-30	EZ530021	Jack Nut Plate	ND-5052	1
17-31	ZS462947	Screw, pan head 2.3x12		2
17-32x	ZW562476	Earth Lug M3		1
17-33x	EJ373623	Pin Contact 61116-1	52-1-1	9
JACK PLATE BLOCK				
17-34	EJ621191	Jack Plate KJ	31-5-118	1
17-35x	ER440921	Carbon/R. RD1/4 27k (J) (Insu. Type)	35-9-5	2
17-36x	ER214290	Carbon/R. RD1/4 4.7k (J) (Insu. Type)	35-9-5	2
17-37x	ER345677	Carbon/R. RD1/4 15k (J) (Insu. Type)	35-9-5	2
17-38x	ER324685	Carbon/R. RD1/4 33k (J) (Insu. Type)	35-9-5	2
17-39	EZ626927	Jack Plate Bracket	MY-5006	1
17-40	ZW554940	Nut M3		4
AMP. ASSEMBLY BLOCK				
17-41	SZ626905	Amp. Side Plate A	MY-5003	1
17-42	SZ626916	Amp. Side Plate B	MY-5003	1
17-43x	EZ627041	Amp. Shield Plate	MY-5007	1
17-44	EZ436217	Collar For Jack	MC-5006	3

17 ILLUSTRATION OF AMP . ASSEMBLY BLOCK

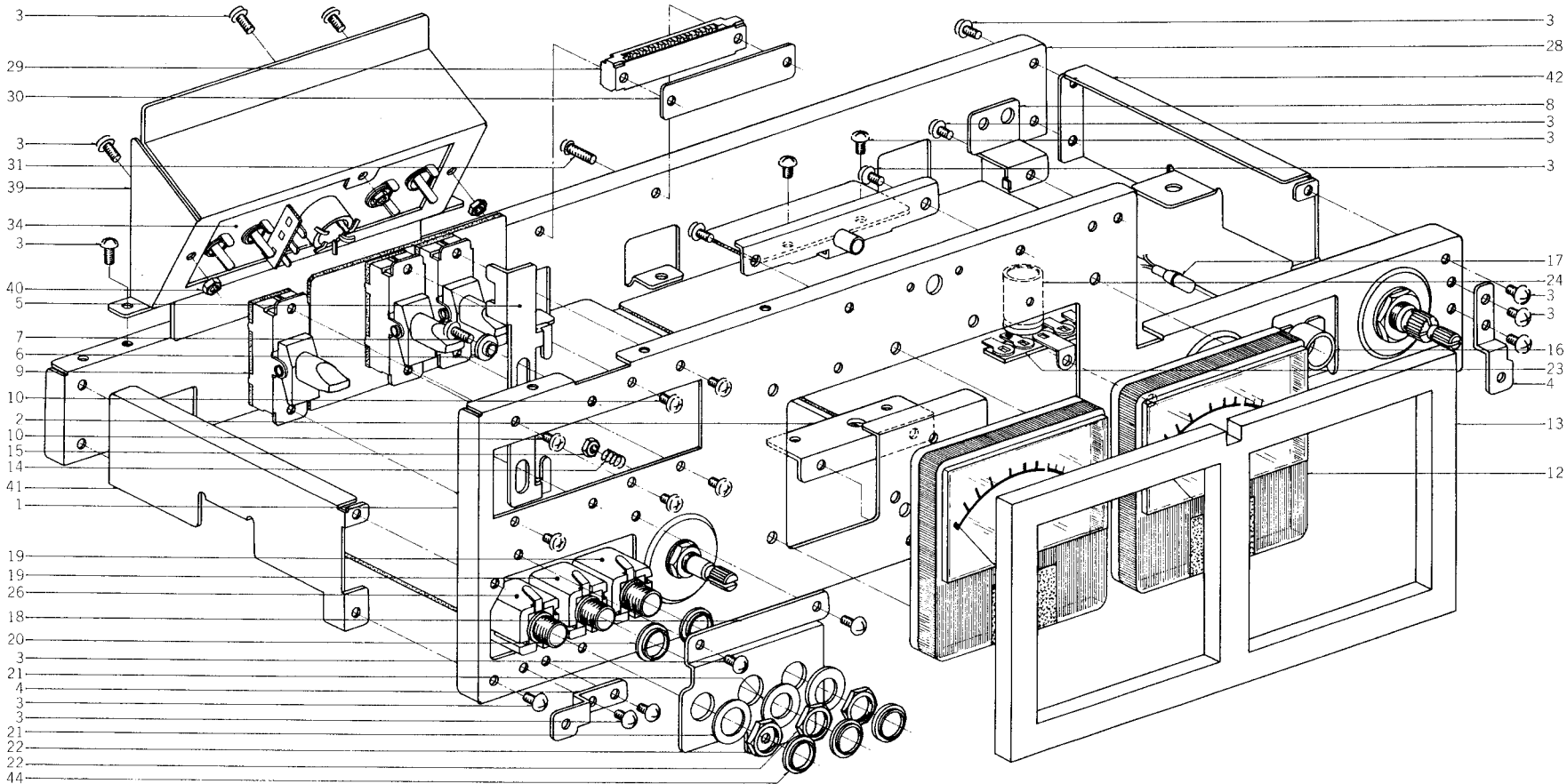

18 PHOTO OF FINAL ASSEMBLY BLOCK



FINAL ASSEMBLY BLOCK

Ref. No.	Parts No.	Description	Schematic No.	Q'ty
FRONT PANEL BLOCK				
18-1x	BZ622394	Front Panel Block Comp.	MY-II	1
18-2	SP631124	Front Panel C	MY-6201	1
18-3	SE626940	Reel Table Escutcheon	MY-6004	2
18-4x	ZW575730	Speed Nut 3 (P Type)	6-3-6	12
18-5	SC627107	Head Cover Base	MY-6005	1
18-6	SE626951	Counter Escutcheon	MY-6006	1
18-7	SE613888	Button Escutcheon A	CW-6021	2
18-8	SE613866	Button Escutcheon C	CW-6016	6
18-9	SE612055	Lamp Lens A (Red)	CH-6314	1
18-10	SE631102	VU Escutcheon	MY-6205	2
18-11x	ZS575392	Screw, pan head 2.6x8		8
18-12x	MH615161	Head Cover Prop	MY-6008	2
18-13x	ZW416698	Nut M4		2
CASE BLOCK				
18-14	BC627186	Case C	MY-6013	1
18-15	SZ622070	Square Foot	MY-6026	2
18-16x	ZS200610	Tapping Screw #1 4x12 (Truss)		4
18-17x	ZS392141	Tapping Screw #1 3x8 (Truss)		2
18-18x	SE627120	Ventilator	MY-6014	1
FINAL ASSEMBLY BLOCK				
18-19x	SZ627085	Side Plate A (Right)	MY-6001	1
18-20x	SZ627096	Side Plate B (Left)	MY-6001	1
18-21x	ZS325495	Tapping Screw #2 3x6		16
18-22x	SZ627298	Panel Support B (Right)	MY-6002	1
18-23x	SZ627311	Panel Support C (Left)	MY-6002	1
18-24	ZS613901	Panel Screw	CW-6031	6
18-25x	EF563681	Fuse 1A 250V	39-1-50	1
18-26	SC627118	Head Cover	MY-6011	1
18-27	SM598983	GX Symbol Plate	KJ-6021	1
18-28	SM630865	Head Cover Name Plate		
		GX-270D	MY-6209	1
18-29	SK631056	Single Knob	MY-6208	1
18-30	SK631078	Double Knob (Upper)	MY-6206	2
18-31	SK631067	Double Knob (Lower)	MY-6207	2

When ordering parts, Please describe Parts Number, Serial Number, and Model Number in detail.

19 LIST OF INTERCHANGEABLE SEMICONDUCTORS

As far as service is concerned, in case the original parts cannot be obtained, the interchangeable parts listed below can be substituted.

ORIGINAL PARTS			INTERCHANGEABLE PARTS	
Description	Parts No.	Utilizing P.C. Board	Description	Parts No.
2SC945 (Q), (R)	ET398711	MY-2036 MY-2221 MY-2222 MY-5016 MY-5017 MY-5202	2SC711 (E), (F) 2SC536 (E), (F) 2SC1647 (R), (S), (E) 2SC1641 (Q), (R), (S), (E)	ET453486 ET370607 ET623733 ET603843
2SC458LG (C)	ET234854	MY-5016 MY-5017	2SC693U (F) 2SC1312S (G), (H)	ET315472 ET603257
2SC1211 (D), (E)	ET511694	MY-2221	2SC1175 (E), (F) 2SC1247A (B), (V)	ET622080 ET511920
2SC1247A (B), (V)	ET511920	MY-2222	2SC1211 (D), (E) 2SC1175 (E), (F)	ET511694 ET622080
2SA564 (Q), (R)	ET538154	MY-2036	2SA733 (Q), (R) 2SA628 (D), (E) 2SA640 (E), (F)	ET538378 ET538110 ET623790
2SD361 (D), (E) 2SD361 (D1), (D2)	ET537300 ET623867	MY-2222 MY-2221	2SC1449 (K), (L), (H) 2SC1061 (B), (C)	ET635815 ET375603
TIP-48	ET621786	MY-2036	TIP-47	ET621775
10D05	ED494583	MY-2222	1N4001	ED511097
10D2	ED224548	MY-2036	1N4004 10D4	ED570273 ED224550
10D4	ED224550	MY-2222	10D6 1N4004	ED224561 ED570273

INDEX

Parts No.	Ref. No. & Symbol No.	Parts No.	Ref. No. & Symbol No.	Parts No.	Ref. No. & Symbol No.	Parts No.	Ref. No. & Symbol No.	Parts No.	Ref. No. & Symbol No.
BA622574	12-1	EC329771	16-C18	EJ255115	17-23	EZ486617	9-6	MT397225	2-10
BA622710	14-1	EC329850	15-C12	EJ300508	9-51x	EZ530021	17-30	MT405268	2-13
BA622721	16-1	EC329861	14-C1	EJ364915	17-29	EZ586326	17-16	MT436860	2-16
BA622732	15-1	EC331328	11-C8	EJ373623	17-33x	EZ606701	4-8	MT488147	2-4
BA624791	11-1	EC331828	12-C4	EJ373634	9-52x	EZ614586	9-30x	MT495606	2-11
BA624802	10-1	EC331828	13-C9	EJ592435	17-19	EZ615047	12-4	MT495617	2-12x
BA624835	13-1	EC346735	12-C13	EJ601481	17-26	EZ615058	10-6	MV368886	3-7
BC627186	18-14	EC350875	13-C4	EJ621191	17-34	EZ615060	12-6	MV537862	4-26
BH622585	1-1x	EC350875	13-C8	EJ631945	9-39	EZ615071	12-7	MV597082	4-4
Bl657112	4-1x	EC364858	9-8	EJ641441	17-11x	EZ615115	17-2	MZ529233	9-46x
BM314741	2-1	EC368256	13-C1	EL593662	17-17	EZ624047	9-13x	MZ302400	7-9
BM600298	3-1x	EC368256	13-C5	EM573748	17-12	EZ624071	11-P11	MZ314605	8-42
BR398430	2-2x	EC368335	14-C2	EO321254	16-L1	EZ625544	8-66	MZ314605	8-50
BR398441	2-3x	EC372148	10-C2	EO333365	16-L2	EZ626894	10-2	MZ314998	2-26
BS622631	8-1x	EC377212	16-C10	EO369178	14-L1	EZ626927	17-39	MZ314998	8-38
BT517274	15-T1	EC379170	16-C16	EO380564	14-L2	EZ627041	17-43x	MZ315000	2-27
BT621922	9-1	EC379192	14-C4	EO496361	15-L1	EZ631080	13-3	MZ315000	8-39
BT621988	9-2x	EC379214	14-C3	EP573658	6-2	HA532743	1-26	MZ397080	8-41
BT621990	9-3x	EC389485	15-C8	EP616500	10-RL3	HA625105	1-18	MZ529391	8-11
BZ600300	3-6	EC389496	16-C19	EP621808	1-33	HA625116	1-19	MZ582030	6-20
BZ622394	18-1x	EC399565	15-C15	EP621808	11-RL1	HP536501	1-23	MZ582030	8-55
BZ622618	5-23x	EC399565	16-C6,7	EP638763	10-RL1,2	HR556582	1-27	MZ596823	4-29
BZ624780	7-1x	EC399565	16-C14	EP650081	8-15	HZ315090	8-58	MZ597093	4-6
BZ624813	5-1x	EC405898	16-C23	ER214290	17-36x	HZ532710	1-8	MZ597126	4-23x
EA382713	1-36x	EC432810	15-C2	ER324685	17-38x	HZ532732	1-13	MZ597137	4-9
EA463206	1-24x	EC432810	15-C13	ER345677	17-37x	HZ532765	1-16	MZ597150	4-13
EA463206	1-24x	EC432810	16-C3	ER365016	9-9x	HZ583176	1-28x	MZ597172	4-12
EA614632	9-28x	EC450055	11-C1	ER376435	8-62	HZ626837	1-2	MZ597644	3-9
EA615093	9-27x	EC450055	11-C3to5	ER376435	10-CR1to7	HZ626848	1-3	MZ597666	3-8
EA624521	9-23x	EC450055	12-C9	ER426892	16-R40	HZ627546	1-20	MZ597690	3-10
EA624532	9-24x	EC450055	15-C19	ER440921	17-35x	MA625825	5-25	MZ606712	4-5
EA624554	9-25x	EC450055	16-C29	ER515070	16-R39	MB625566	2-23	MZ625151	8-25
EA624565	9-26x	EC450527	13-C3	ER554556	8-79	MB625566	8-77	MZ625342	8-45
EA625138	1-32	EC450527	13-C7	ER575640	9-12	MC621887	8-60	MZ625421	6-10
EA628075	9-18	EC450527	15-C21	ER593346	12-R20	MH257477	8-20	MZ625443	6-14
EC220127	11-C7	EC456041	11-C9to11	ES249974	5-15	MH333737	2-29	MZ625454	6-16
EC220151	12-C11	EC462611	10-C5,6	ES479395	8-67	MH333737	8-32	MZ625511	8-57
EC220151	16-C20	EC467133	15-C4	ES479485	9-53	MH527635	8-6	MZ625555	8-73
EC220364	15-C18	EC487157	12-C7	ES562465	5-33	MH528513	8-5	MZ625577	3-17
EC220364	16-C5	EC520626	8-64	ES573456	8-61	MH529233	1-11	MZ625768	6-1
EC220678	13-C10	EC536927	8-65x	ES573478	8-3	MH533913	6-6	MZ625770	6-5
EC220678	15-C1	EC551160	8-69	ES621178	8-68x	MH573957	1-7	MZ625803	5-24
EC220678	15-C11	EC557166	12-C8	ES621898	8-74	MH581927	8-23	MZ625858	9-15x
EC220678	16-C2	EC558202	16-C25	ES621977	17-9	MH615161	18-12x	MZ626861	9-14x
EC220678	16-C12	EC558235	16-C26	ES622023	14-SW1	MH625094	1-30	MZ627030	17-28
EC220768	17-24	EC564952	10-C1	ES622034	14-SW2	MH625140	8-21	MZ627210	8-29
EC220994	11-C6	EC565896	8-70x	ET234854	15-TR1to4	MH625162	4-28	MZ627265	5-27
EC220994	13-C2	EC593763	9-10	ET234854	16-TR1to4	MH625162	8-27	MZ627287	17-18
EC220994	13-C6	ED219464	15-D2	ET398711	10-TR2	MH625195	8-31	MZ627636	9-4
EC220994	16-C22	ED224548	12-D2to5	ET398711	11-TR1to9	MI651903	4-20	MZ629414	9-45
EC250582	12-C3	ED224550	6-3x	ET398711	11-TR11,12	ML314976	2-24	MZ630876	7-2
EC250582	12-C3	ED224550	8-16x	ET398711	13-TR1to4	ML314976	8-34	MZ630898	7-5
EC250582	12-C3	ED224550	10-D9to13	ET399846	12-TR3,4	ML396810	8-33	MZ630900	7-6
EC250582	12-C3	ED357794	10-D5	ET399846	12-TR6	ML580465	5-36	MZ630911	7-8
EC250582	12-C3	ED494583	10-D1to4	ET478001	12-TR8	ML615126	17-5	MZ630922	8-19
EC250582	12-C3	ED494583	17-25x	ET478001	12-TR1,2	ML627197	8-48	MZ630933	8-17
EC251122	12-C12	ED557447	12-D1	ET478001	15-TR5,6	ML627221	8-49	MZ630944	8-2
EC251122	12-C5	ED560913	11-D2to7	ET478001	16-TR5,6,7	ML627232	8-35	MZ631001	5-2
EC251122	12-C5	ED560913	11-D9to14	ET511694	11-TR10	ML627254	6-8	MZ631012	5-11
EC251291	12-C1	ED560913	11-D34,35	ET511920	10-TH1	ML630887	7-3	MZ631045	13-2
EC290520	15-C5	ED560913	13-D1,2	ET537300	10-TR3	ML630955	5-3	MZ647133	9-16x
EC290520	15-C16	ED570475	15-D1	ET538154	12-TR5	ML630966	5-4	MZ651881	4-3
EC290520	16-C1	ED591333	13-D3	ET621786	9-19	ML630977	5-12	MZ810191	5-28
EC290520	16-C4	ED593357	12-TH1	ET623867	12-TR7	ML630988	5-14	SB631135	7-11
EC290520	16-C15	ED624903	1-34x	EV464196	15-VR3	ML630990	5-10	SB631146	7-12
EC313121	10-C4	ED624903	10-D6to8	EV464220	15-VR1	MP625048	6-26	SB631157	7-13
EC320051	11-C2	ED624903	11-D1	EV520806	13-VR1,2	MR317507	2-19	SB631168	7-14
EC320051	12-C10	ED624903	11-D8	EV522797	16-VR2	MR597115	4-22	SC627107	18-5
EC320051	15-C7	ED624903	11-D15to33	EV554670	10-VR1	MS342000	2-6	SC627118	18-26
EC320051	15-C17	EF511637	9-35x	EV621955	12-VR1	MS597148	4-10	SE597161	4-14
EC320051	15-C20	EF563681	9-34x	EV621966	12-VR2	MS597655	3-11	SB612055	18-9
EC320051	16-C8	EF563681	18-25x	EV622056	15-VR2	MS615014	5-26	SE613866	18-8
EC320051	16-C11	EF563703	9-33	EV622078	16-VR1	MS625072	1-4	SE613888	18-7
EC320051	16-C17	EF601942	9-37x	EW374894	9-40x	MS625184	6-23	SE626940	18-3
EC320051	16-C21	EF602550	9-36x	EW516600	9-42x	MS625432	6-11	SE626951	18-6
EC329771	15-C6	EF624543	9-38x	EW524845	9-41x	MT255420	2-5	SE627120	18-18x
EC329771	15-C14	EJ205986	9-44x	EW604585	9-43x	MT297663	2-8	SE631102	18-10
EC329771	15-C22	EJ222748	7-10	EZ225101	17-21	MT314987	2-25	SK597633	3-5
EC329771	16-C9	EJ233370	9-17	EZ225180	17-20	MT314987	8-37	SK631056	18-29
EC329771	16-C13	EJ255115	8-78	EZ436217	17-44	MT317485	2-17	SK631067	18-31

INDEX

Parts No.	Ref. No. & Symbol No.	Parts No.	Ref. No. & Symbol No.	Parts No.	Ref. No. & Symbol No.	Parts No.	Ref. No. & Symbol No.	Parts No.	Ref. No. & Symbol No.
SK631078	18-30	ZS422076	17-10	ZW601075	4-15				
SK631282	5-22	ZS422965	5-34	ZW601075	5-29				
SK631304	8-71	ZS424056	2-21	ZW603764	3-15x				
SK631326	6-27	ZS424056	9-5	ZW603775	3-16x				
SM598983	18-27	ZS425981	2-15x	ZW603786	3-13				
SM630865	18-28	ZS432674	5-5	ZW603797	3-14x				
SM647245	9-55x	ZS432674	8-76	ZW603990	4-2				
SP631124	18-2	ZS432843	8-75	ZW604012	4-11				
SZ615137	17-4	ZS447840	17-7	ZW605698	3-3				
SZ615148	17-8	ZS455207	9-32x	ZW621876	8-52x				
SZ622070	18-15	ZS462925	9-29x	ZW622001	8-12				
SZ626905	17-41	ZS462947	17-31	ZW622012	8-13				
SZ626916	17-42	ZS477876	1-29	ZW625241	17-6				
SZ627085	18-19x	ZS483502	5-16	ZW649618	4-24x				
SZ627096	18-20x	ZS483502	8-4						
SZ627298	18-22x	ZS483502	8-63						
SZ627311	18-23x	ZS484828	4-17						
SZ631091	17-13	ZS499331	4-7						
TA627028	17-1	ZS516644	2-20						
TC515575	5-6	ZS575392	18-11x						
ZG255633	2-7	ZS593796	4-21						
ZG303300	1-17	ZS608321	8-54						
ZG314706	5-19	ZS608477	1-21						
ZG315011	2-28	ZS608512	1-14						
ZG315011	8-43	ZS609298	11-2						
ZG316833	5-20	ZS613901	18-24						
ZG317496	2-18	ZW259738	8-9						
ZG371114	5-21	ZW260010	6-21						
ZG371114	8-44	ZW270088	2-9						
ZG394378	5-18	ZW270088	5-9						
ZG456120	7-4	ZW270088	6-7						
ZG466312	1-9	ZW270088	8-14						
ZG466312	1-15	ZW270101	4-25						
ZG529211	8-8	ZW270101	5-31						
ZG580533	17-14	ZW270101	8-10						
ZG580768	6-22	ZW270134	6-15						
ZG580768	8-56x	ZW270134	8-53x						
ZG614970	5-32	ZW273633	4-16						
ZG625375	8-51	ZW273756	5-35						
ZG625465	6-18	ZW273756	8-7						
ZG632553	5-7	ZW273756	8-24x						
ZG646020	4-18	ZW273756	9-21						
ZS200395	5-38	ZW273756	10-4						
ZS200610	18-16x	ZW273756	11-3						
ZS201150	4-19	ZW273756	12-3						
ZS201508	1-25	ZW273756	17-15						
ZS325495	7-7	ZW273778	2-14x						
ZS325495	8-72	ZW273802	11-4						
ZS325495	9-11	ZW273835	1-10						
ZS325495	10-7	ZW273881	9-47x						
ZS325495	13-4	ZW273892	9-48x						
ZS325495	17-3	ZW273914	1-12						
ZS325495	18-21x	ZW273914	6-12						
ZS344463	8-59	ZW273914	6-25x						
ZS369900	1-31	ZW290283	2-30						
ZS379350	6-19	ZW290283	5-13						
ZS379350	9-31x	ZW290283	8-36						
ZS392141	18-17x	ZW334653	6-17						
ZS403222	2-22	ZW413188	9-7						
ZS413201	1-6	ZW413256	1-22						
ZS413201	8-22x	ZW416693	6-13						
ZS413201	9-49x	ZW416693	8-26x						
ZS413234	3-12	ZW416693	9-50x						
ZS414044	1-5	ZW416698	6-24x						
ZS414178	9-54x	ZW416698	8-30x						
ZS417216	8-40	ZW416698	18-13x						
ZS421806	4-31	ZW419646	5-30						
ZS421806	9-20	ZW420682	8-47						
ZS421806	10-3	ZW436026	17-27x						
ZS421806	12-2	ZW452373	5-8						
ZS422076	1-35	ZW535094	5-37						
ZS422076	4-27	ZW554624	17-22						
ZS422076	5-17	ZW554940	17-40						
ZS422076	5-39	ZW555693	6-9						
ZS422076	6-4	ZW562476	17-32x						
ZS422076	8-18	ZW575730	18-4x						
ZS422076	8-28	ZW580173	8-46						
ZS422076	9-22	ZW593212	4-30						
ZS422076	10-5	ZW597543	3-2						
ZS422076	12-5	ZW597622	3-4						

SECTION 3

SCHEMATIC DIAGRAM

1. GX-270D SCHEMATIC DIAGRAM

GX-270D (MECHA.)

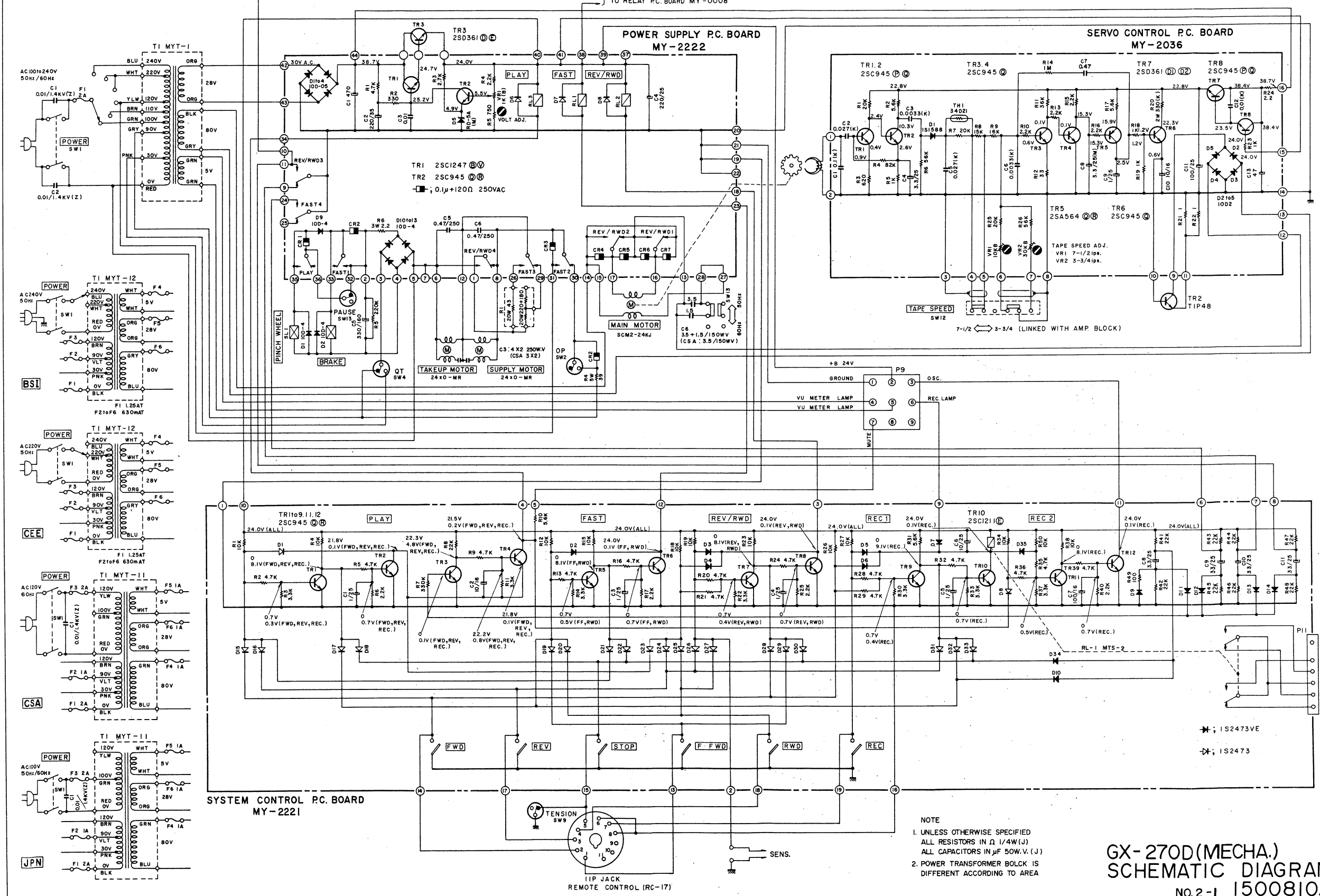

NOTE
 1. UNLESS OTHERWISE SPECIFIED
 ALL RESISTORS IN Ω 1/4W(J)
 ALL CAPACITORS IN μ F 50W.V.(J)
 2. POWER TRANSFORMER BLOCK IS
 DIFFERENT ACCORDING TO AREA

GX-270D(MECHA.)
 SCHEMATIC DIAGRAM
 NO.2-1 1500810A
 2C

GX-270D (AMP.)

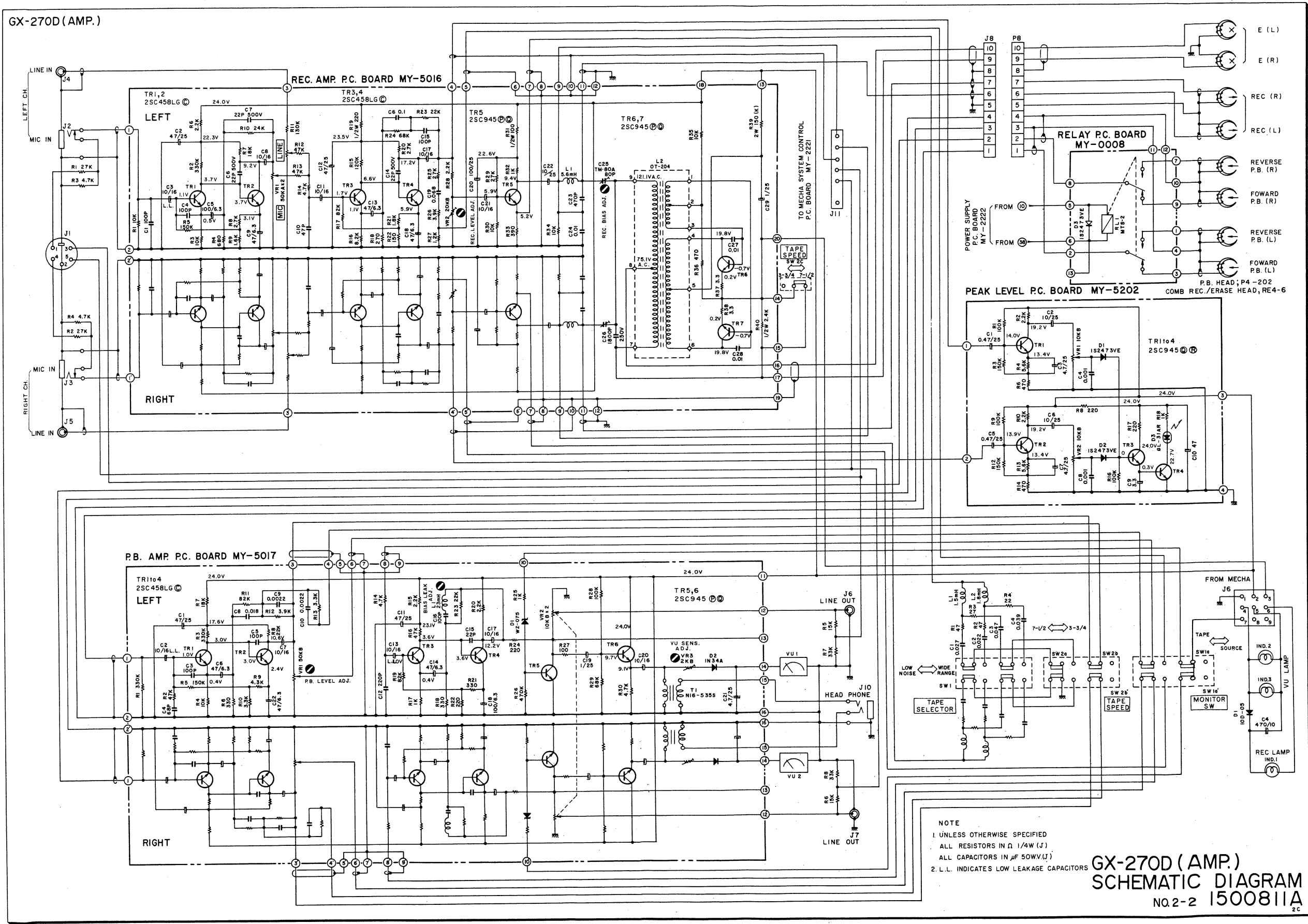

NOTE
 1. UNLESS OTHERWISE SPECIFIED
 ALL RESISTORS IN Ω 1/4W (J)
 ALL CAPACITORS IN μ F 50WV(J)
 2. L.L. INDICATES LOW LEAKAGE CAPACITORS

GX-270D (AMP.)
 SCHEMATIC DIAGRAM
 NO.2-2 1500811A
 2C

G 2700

 **AKAI ELECTRIC CO.,LTD.**
AKAI TRADING CO.,LTD.

(P.O. BOX 21, Tokyo International Airport, Japan)
12-14, 2-chome, Higashi-Kojiya, Ohta-ku, Tokyo, Japan
TELEPHONE: TOKYO (742) 5 1 1 1
CABLE: HIFI AKAI TOKYO TELEX: J26261

Printed No. 1501448 Printed in Japan Price \$ 8.00