

(ELTA 2018) **BG**

14" COLOUR TELEVISION

- **ON SCREEN DISPLAY**
- **30 PROGRAMMES MEMORY**
- **WITH INFRA-RED REMOTE CONTROL**

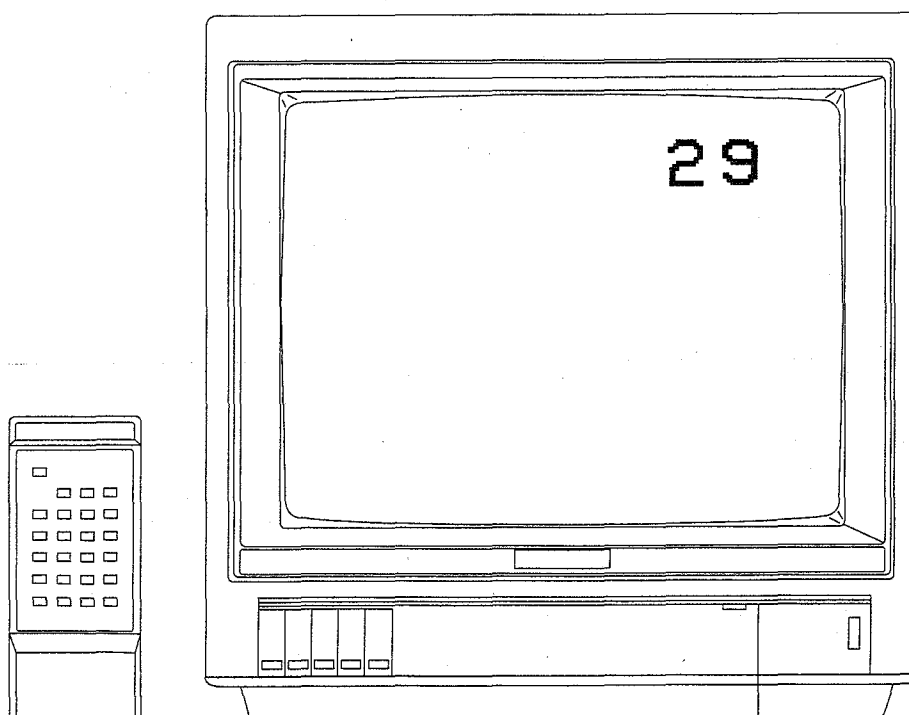

SERVICE MANUAL

CONTENTS

	Page
X-RAY RADIATION PRECAUTION	2
SAFETY PRECAUTION	2
PRODUCT SAFETY NOTICE	2
OPERATION CONTROLS	3
MECHANICAL DISASSEMBLES	4
GENERAL ADJUSTMENT INSTRUCTION	5-14
CIRCUIT DIAGRAM	15-17
BLOCK DIAGRAM	18
BOTTOM AND COMPONENT VIEW OF P.C. BOARD	19-21
EXPLODED VIEW OF REMOTE CONTROL UNIT	22
EXPLODED VIEW OF MAIN UNIT	23
MECHANICAL PART LIST FOR REMOTE CONTROL UNIT	24
MECHANICAL PART LIST FOR MAIN UNIT	24
ELECTRICAL PARTS LIST	25-31
SPECIFICATIONS	32

CAUTION

Before servicing the chassis, read the "Safety Precaution", "X-Ray Radiation Precaution" and "Product Safety Notice" on Page 2 of this manual."

GENERAL ALIGNMENT AND SAFETY TEST FOR MODEL:

X-RAY RADIATION PRECAUTION

1. Excessive high voltage can produce potentially hazardous X-Ray Radiation. To avoid such hazards, the high voltage must not be above the specified limit. The normal value of the high voltage of this receiver is 23KV at zero beam current (minimum brightness) under 220V AC power source. The high voltage must not, under any circumstances, exceed 28KV.
2. Each time a receiver requires servicing, the high voltage should be checked following the High Voltage Check procedure in this manual. It is recommended the reading of the high voltage be recorded as a part of the service record. It is important to use an accurate and reliable high voltage meter.
3. The primary source of X-Ray Radiation in this TV Receiver is the picture tube. For continued X-Ray Radiation protection, the replacement tube must be exactly the same type tube as specified in the parts list.
4. Some parts in this receiver have special safety - related characteristics for X-Ray Radiation protection. For continued safety, parts replacement should be undertaken only after referring to the Product Safety Notice below.

SAFETY PRECAUTION

Warning: Service should not be attempted by anyone unfamiliar with the necessary precautions on this receiver.

The following are the necessary precautions to be observed before servicing this chassis.

1. Since the power supply circuit of this receiver is directly connected to the AC power line, an isolation transformer should be used during any dynamic service to avoid possible shock hazard.
2. Always discharge the picture tube anode to the CRT conductive coating before handling the picture tube. The picture tube is highly evacuated and if broken, glass fragments will be violently expelled. Use shatter proof goggles and keep picture tube away from the unprotected body while handling.
3. When replacing a chassis in the cabinet, always be certain that all the protective devices are put back in place, such as; non-metallic control knobs, insulating covers, shields, isolation resistor-capacitor network etc.
4. When replacing parts or circuit boards, disconnect the power cord.
5. When replacing a high wattage resistor (Metal oxide film resistor) on circuit board, keep the resistor 10mm (1/2 in.) away from circuit board.
6. Connection wires must be kept away from components with high voltage or high temperature.
7. If any fuse in this TV receiver is blown, replace it with the FUSE specified in the chassis parts list.
8. The receiver is designed to operate with 220 V (50Hz) AC mains.

PRODUCT SAFETY NOTICE

Many electrical and mechanical parts in this chassis have special safety-related characteristics. These characteristics are often passed unnoticed by a visual inspection and the X-Ray Radiation protection afforded by them cannot necessarily be obtained by using replacement components rated for higher wattage, etc. Replacement parts which have these special safety characteristics are identified in this manual and its supplements, electrical components having such features are marked with

"" on the schematic diagram and the part list.

Before replacing any of these components, read the parts list in this manual carefully. The use of substitute replacement parts which do not have the same safety characteristics as specified in the parts list may create shock, fire, X-Ray Radiation or other hazards.

OPERATION CONTROLS

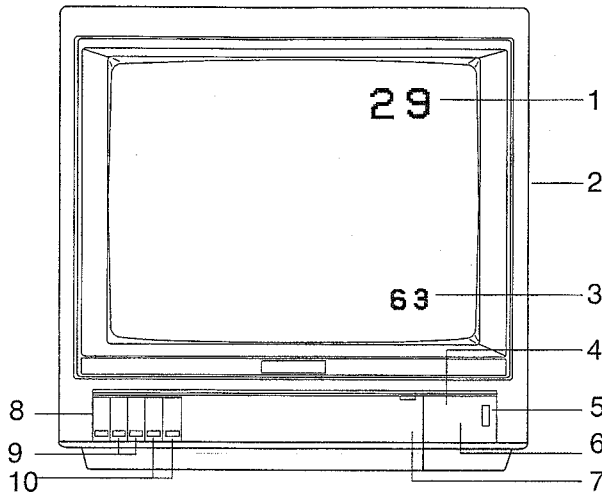

Fig 1

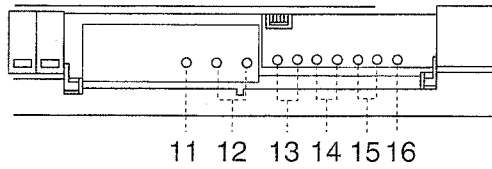

Fig 2

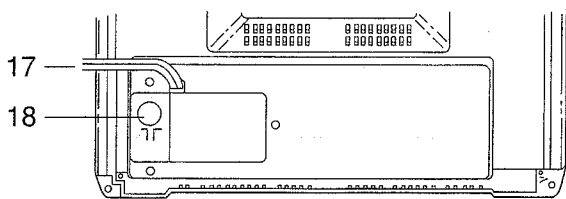

Fig 3

1. Programme position indicator (0-29)
2. Speaker
3. Volume level indicator (0-63)
Sound Mute-indicator (0)
4. Infra-Red Receiving window
5. Main ON/OFF switch Ⓚ
6. Power indicator Ⓚ
7. Controls Compartment Door
8. Sub-power
9. Volume \triangleleft \trianglerightarrow +/-
10. Programme \triangleleft \trianglerightarrow +/-
11. Contrast ●
12. Brightness \star +/-
13. Colour \odot +/-
14. Auto-search Tuning +/-
15. Fine-Tuning +/-
16. AFT ON
17. AC Mains Lead
18. Antenna Terminal (75ohm)

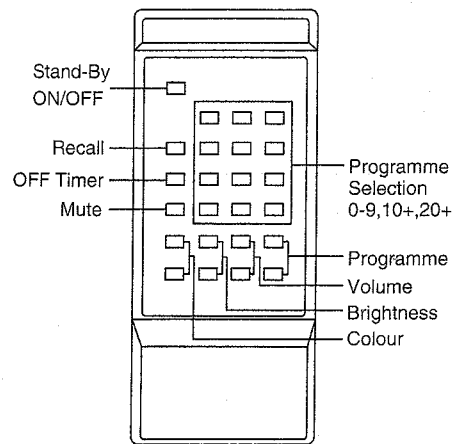

Fig 4

WARNING: BEFORE SERVICING THIS CHASSIS, READ THE "X-RAY RADIATION PRECAUTION", SAFETY PRECAUTION" AND "PRODUCT SAFETY NOTICE" ON PAGE 2 OF THIS MANUAL

CABINET BACK REMOVAL (See Figure 5)

1. Disconnect the antenna leads from the antenna terminals.
2. Remove 3 screws (A) securing the antenna terminal board to the Cabinet Back
3. Remove 4 screws (B) securing the Cabinet Back to the Cabinet Front and detach the cabinet back.

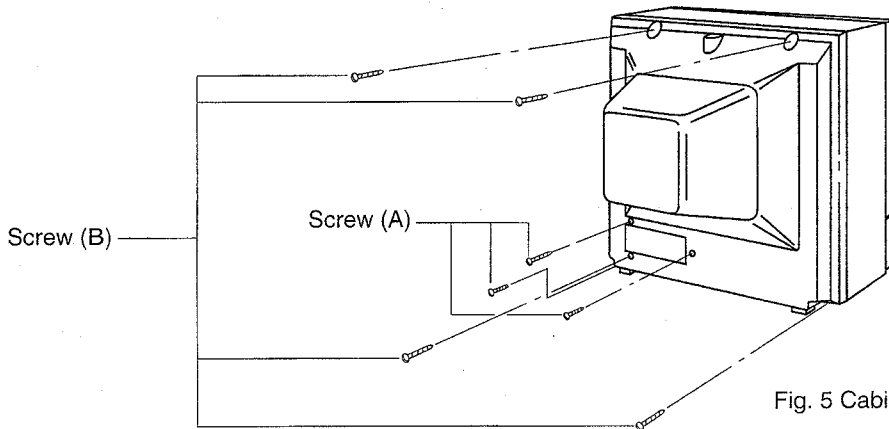

Fig. 5 Cabinet Back Removal

CHASSIS REMOVAL (See Figure 6)

Following the steps under Cabinet Back Removal, proceed as follows:-

1. Unplug the CRT grounding wire socket connected to the CRT Socket Board.
2. Detach the picture tube anode cap.

Notice: Certainly discharge the high potential of the picture tube anode to the receiver chassis before removing the anode cap.

3. Detach the CRT Socket (CRT Socket Board).
4. Take out the chassis from the chassis holder.

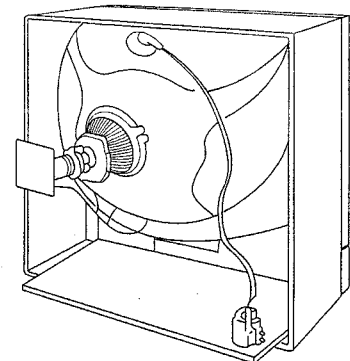

Fig. 6 Chassis Removal

PICTURE TUBE REMOVAL (See Figure 7)

Following the steps under CHASSIS REMOVAL proceed as follows:

1. Place the cabinet with the front down on a rolled pad or some suitable cushion placed near the top edge of the front panel.
2. Remove 4 screws securing the picture tube to the cabinet, and detach the CRT with the degaussing coil, then grasp the face plate edge of the picture tube with both hands and take out the picture tube.
3. Detach the CRT grounding wire which is attached to the picture tube lugs with spring.

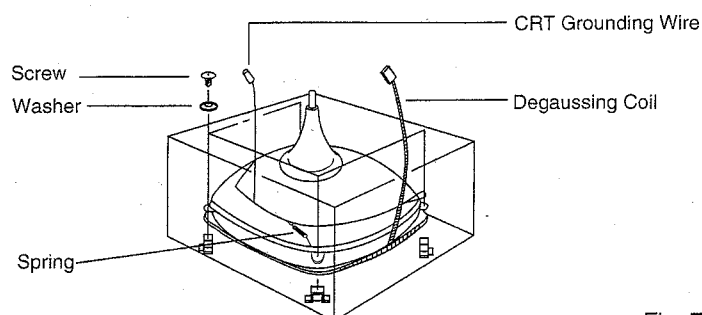

Fig. 7

GENERAL ADJUSTMENT INSTRUCTION

This receiver is transistorized and special care should be taken when servicing. Read the following matters that demand special attention before attempting adjustment.

1. Adjustment requires an exact procedure and should be undertaken only when necessary.
2. An isolation transformer should be used during any dynamic service to avoid possible shock hazard.
3. The test equipment specified or its equivalent is required to perform the alignment properly. Use of equipment which does not meet these requirements may result in improper alignment.
4. Correct matching of the equipment is essential. Failure to use proper matching will result in responses which can not represent the true operation of the receiver.
5. The AC power line voltage should be kept 215 to 225 volts (50Hz) during alignment.
6. Do not attempt to connect or disconnect any wire while the receiver is in operation. Make sure the power cord is disconnected before replacing parts in the receiver.
7. Unless otherwise noted, do not perform any adjustment until the receiver has been turned on for at least 10 minutes.

I. Picture And Sound I.F. Adjustment

Test Equipment:

1. AM/FM signal generator (4.5MHz-6.5MHz).
2. Sweep/Marker signal generator (30MHz-60MHz).
3. Sync. oscilloscope.
4. Oscilloscope (voltage sensitivity over 10mV and input impedance over 1 Mohm, below 10PF).
5. Probe (Low capacitance).
6. High impedance electronic voltmeter on VTM (Input impedance having 100K ohm/V at least).
7. DC power supply (Source such as battery or a well regulated and isolated DC bias supply).

(A) Picture I. F. and AFC Adjustment

(a) P.I.F. Alignment:

1. Connect the signal output of sweep/marker generator to the Tp of Tuner through 1K ohm resistor and 1000PF.
2. Connect the sync oscilloscope input with 100 ohm resistor in series to TP103 (Q102-Emitter).
3. Apply a+8V DC dummy AGC bias to TP104 (pin 5 of 1C101) through 470 ohm resistor.

4. Apply a+3V DC to TP110 (pin 3 of IC405) and TP111 (pin 4 of IC405) through 100 ohm.

5. Tune T102 for 60% level of 38.9MHz as shown in Fig. 10.

6. Tune T101 for 35% level of 34.47 MHz as shown in Fig. 10.

(b) AFC Alignment

1. Reconnect the sync. oscilloscope input with 1M ohm resistor in series to TP105 (pin 14 of IC101).

2. Adjust T103 for the marker (38.9MHz) of AFC wave form the centre position. (Fig. 11).

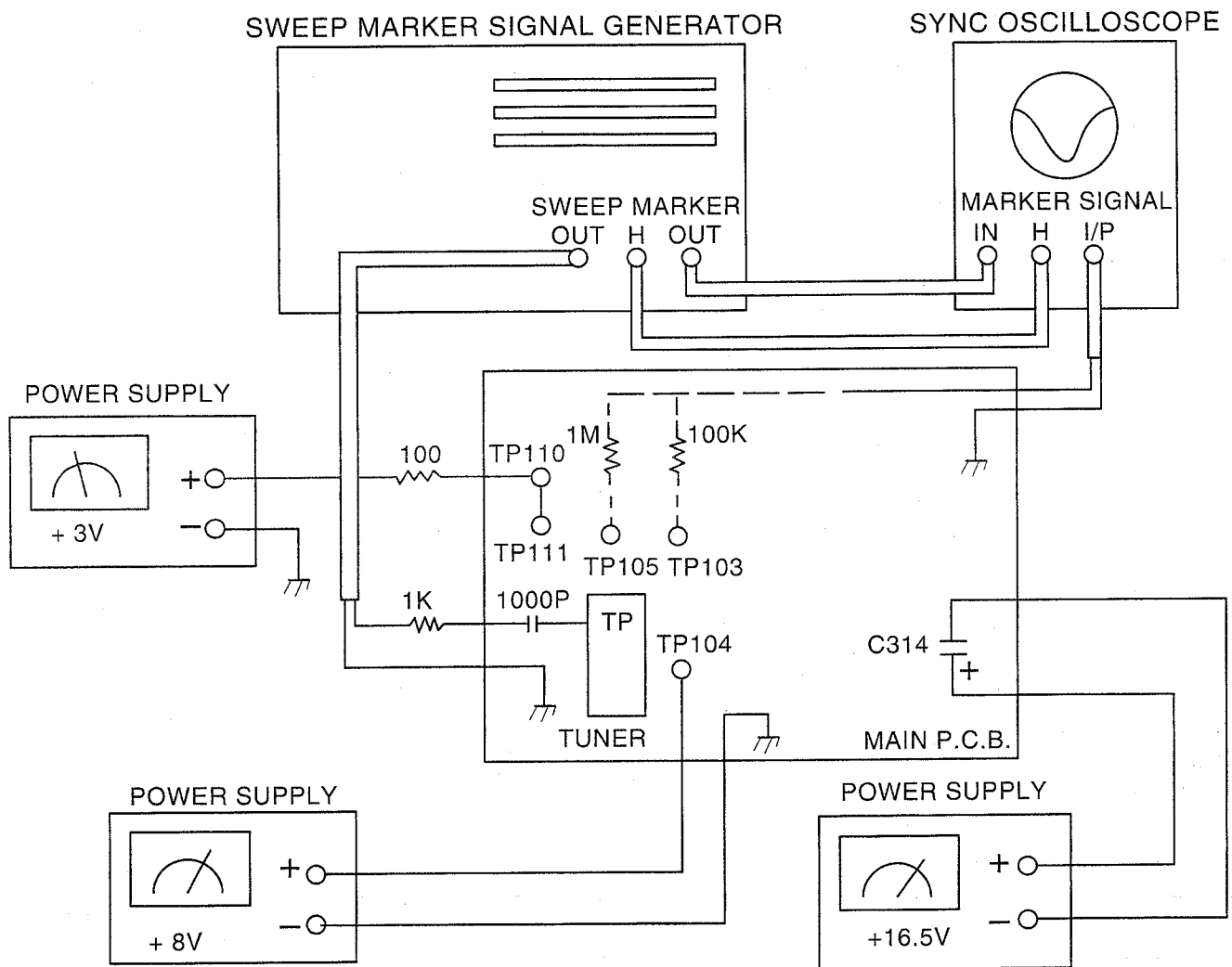
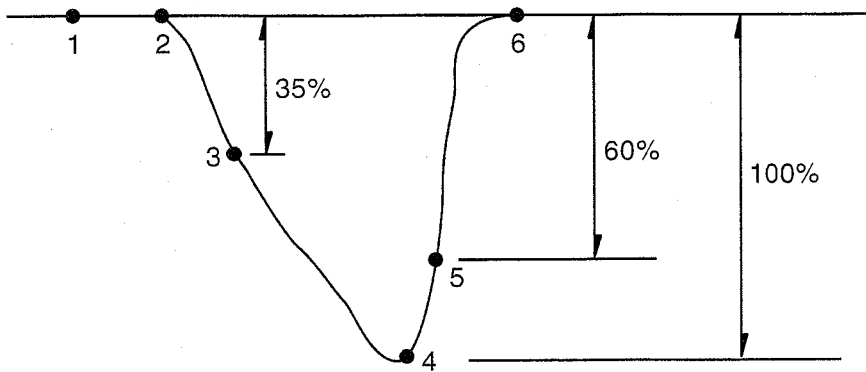

Fig. 8



P.I.F. RESPONSE:

NO	Marker of B/G
1	31.9 MHz
2	33.4 MHz
3	34.47 MHz
4	37.9 MHz
5	38.9 MHz
6	40.4 MHz

Fig. 9 P.I.F. Response Curve

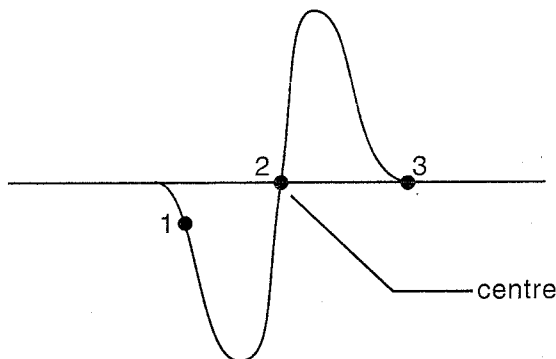

AFC Response

No	Marker of B/G
1	37.9 MHz(+)
2	38.9 MHz (0)
3	40.4 MHz (-)

Fig. 10 AFC Response Curve.

(B) S.I.F. Alignment

1. The signal from AM/FM signal generator which is set at 5.5MHz with AF400Hz, 30% FM modulation, is applied to TP107 (between C127 and C128) through a 1K ohm resistor and a 1000pf capacitor as shown in Fig. 13.
2. Short TP104 (pin 5 of IC101) to ground.
3. Connect the oscilloscope input to TP109 (pin 23 of IC101)
4. Apply a +16.5V DC across C314 (TP108).
5. Adjust T104 for the marker (5.5MHz) of SIF waveform at the centre position Fig. 12.

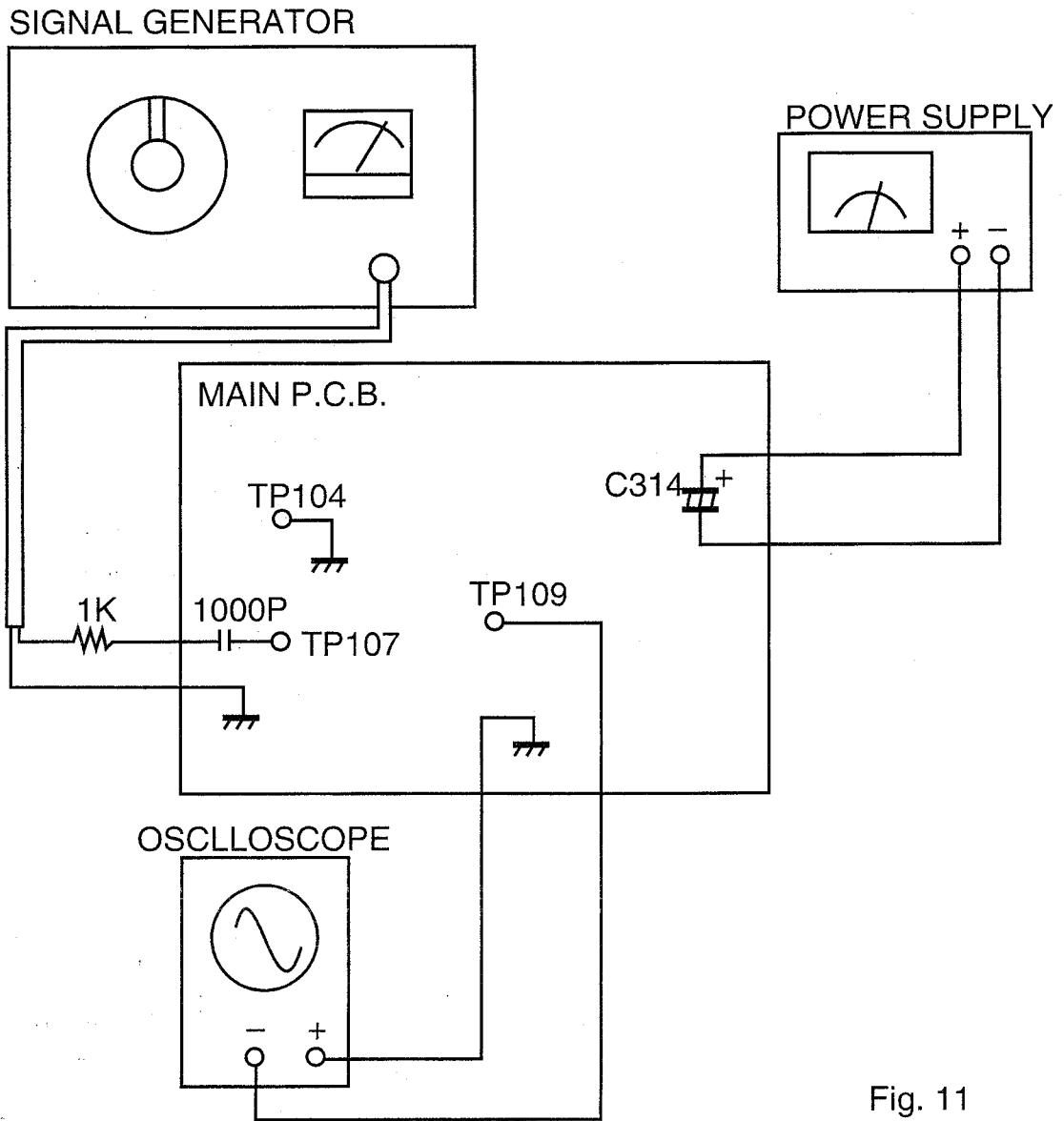

Fig. 11

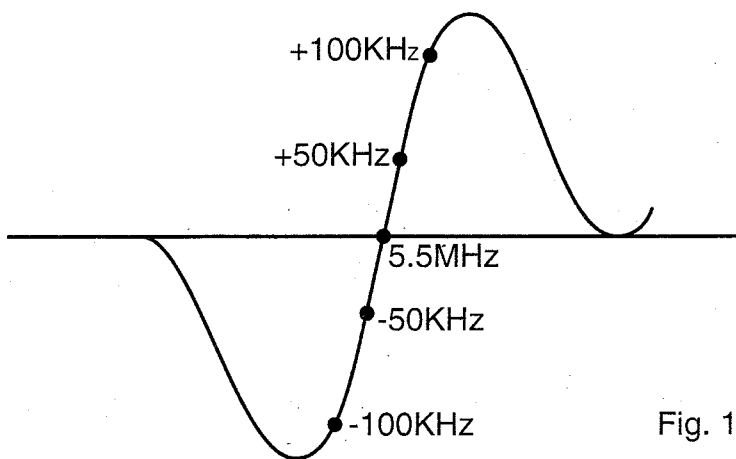

Fig. 12 SIF Response Curve

II. General Adjustment

1. Automatic Degaussing

An automatic degaussing coil is attached around the picture tube, degaussing the tube properly in about one second after the set is switched on. If the receiver is moved or faced in a different direction, the power must be switched off at least 15 minutes in order that the automatic degaussing circuit operates properly. External degaussing is necessary if the automatic degaussing proves ineffective after the set is moved. External degaussing is done by moving a degaussing coil clockwise in front of the face plate and then switch off the degaussing coil. If residual colour spots are still found on the screen, adjust the color purity and convergence.

2. B + 105V Adjustment

CAUTION: To avoid X-Ray hazards, B+ voltage must be set correctly at 105V position.

- (a) Make sure the AC Power supply is 220V, 50Hz.
- (b) Switch on the TV Receiver, tune in an active channel and adjust Brightness/Contrast for maximum.
- (c) Connect TP601 (Q606-Emitter) on the Main PCB to a reliable DC voltmeter.
- (d) Adjust VR601 on Main PCB for $B + 105V \pm 1\%$ voltage reading

3. High Voltage Check

CAUTION: There is no high voltage adjustment in this chassis, B+ 105V voltage directly relates to the high voltage, it must be properly adjusted to insure the correct high voltage. The high voltage must not exceed 28KV under any conditions.

- (a) Connect an accurate high voltage meter to the second anode cap of the picture tube.
- (b) Turn on the receiver, set Brightness and Contrast controls to minimum. (Zerobeam current)
- (c) Make sure the high voltage does not exceed 28 KV.
- (d) No matter whether the luminance, contrast and chrominance controls are set to maximum or minimum, the high voltage must be kept under 28KV.

4. AFC Comparator Adjustment

- (a) Connect a high impedance DC voltmeter to TP401 (pin 2 of IC402)
- (b) Adjust VR401 for $4.2V \pm 0.2$ reading
- (c) Reconnect a voltmeter to TP402 (pin 8 of IC402)
- (d) Adjust VR402 for $7.8V \pm 0.2$ reading

5. Focusing Adjustment

- (a) Receive the philips pattern signal
- (b) Set the contrast control to the maximum position.
- (c) Adjust focus control of flyback transformer for a well-defined, sharpest display in the centre of the screen.

6. Height Adjustment

- (a) Receive the philips pattern signal.
- (b) Adjust the height control (VR205) to slightly overscan the screen.

7. Horizontal Position

- (a) Receive the philips pattern.
- (b) Adjust horizontal hold control (VR203) to the centre

8. Vertical Hold Adjustment

- (a) Receive the philips pattern.
- (b) Short TP201 (pin 37 of IC202) to GND by jumper wire.
- (c) Connect a frequency counter to TP202 (between C306 and C307).
- (d) Adjust Vertical Hold control (VR204) for 47Hz reading.

9. Colour Syne. Adjustment

- (a) Tune in a colour bar signal.
- (b) Set the colour control to maximum.
- (c) Cut off the colour killer by connection the TP203 (pin 2 of IC202) and TP 204 (pin 12 of IC202) with 10K ohm resistor.
- (d) Short TP205 (L206) to GND by jumper wire.
- (e) Adjust the colour sync variable capacitor (C242) for the colour bar pattern stand still or drifts slowly across the picture screen.

10. PAL Matrix Adjustment

- (a) Tune in a DEM pattern signal of Philips signal Generator.
- (b) Use oscilloscope with 2 channels input and set to "X-Y" mode.
- (c) Channel 1 (X) is connected to TP206 (pin 21 of IC202) (R-Y)
- (d) Channel 2 (Y) is connected to TP207 (pin 22 of IC202) (B-Y)
- (e) Adjust amplitude balance VR202 until the centre points of the two wave forms bring together (Fig. 13)
- (f) Adjust T205 until all other points of two waveforms bring together (Fig.13)
- (g) Adjust T206 to obtain the maximum hexagon.

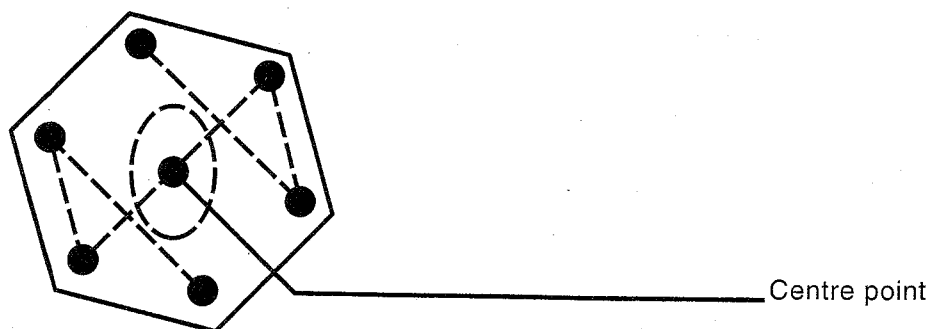

Fig 13 Matrix Vector Diagram.

11. Delay AGC Adjustment

- (a) Tune in the colour bar pattern signal (CH12-224.25MHz)
- (b) Set input signal level at 60 dB
- (c) Connect a high impedance DC Voltmeter to tuner AGC terminal.
- (d) Adjust RF AGC control (VR101) for 5.5V +0.2V reading.
- (e) Increase input signal level to 100 dB.
- (f) Check for normal picture, sound and sync.

12. White Balance Adjustment

- (a) Set brightness control to minimum.
- (b) Set the R.G.B. cut-off (VR501, VR502, VR503) at the centre position.
- (c) Rotate the G.B. drive controls (VR504, VR505) fully counter-clockwise first, then clockwise rotate back to 1/3 position.
- (d) Turn the screen control to minimum position.
- (e) Disconnect the Y signal output terminal connector.
- (f) Short TP202 (between C306 and C307) to GND by jumper wire.
- (g) Rotate the screen control gradually clockwise until the first horizontal line appears on the screen.
- (h) If the first horizontal line is in red, adjust VR502, VR503 to increase the green and blue component level to get a white horizontal line.
- (i) Remove the Jumper wire, connect back the Y signal output terminal and switch back to TV.
- (j) Receive the philips pattern signal and set the contrast colour control to minimum and brightness control to maximum
- (k) Adjust VR504, VR505 to maintain a good white balance at the brightest part of screen.

13. On-Screen Position Adjustment

- (a) Select the position "29" by the programme button (+ or -).
- (b) Tune in the philips pattern signal.
- (c) Press the "Recall" button once, the large character size of programme No. will be changed to small size for approx. 3 seconds.
- (d) Adjust VR403 for the programme No. "29" (small size) position as shown in Fig. 14.

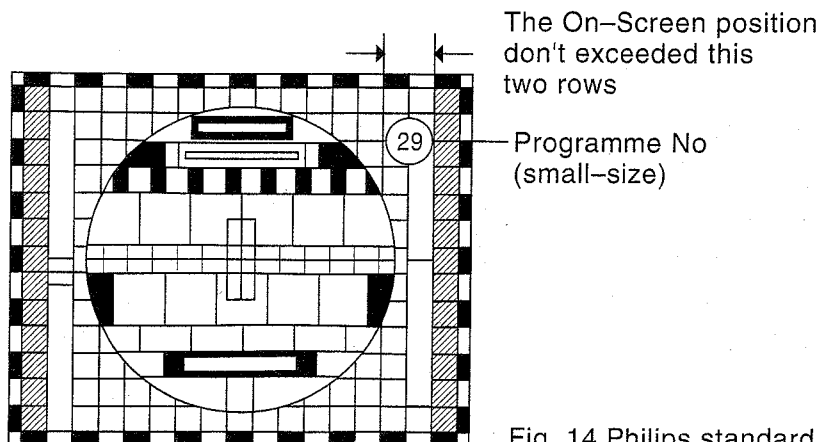

14. Sub-Brightness Adjustment

- (a) Tune in Philips Greyscale pattern signal.
- (b) Set the Brightness and contrast control to the minimum
- (c) Adjust sub-brightness control (VR404) until the 2 right identical steps of Greyscale pattern just appears on the screen.

III. Color Purity And Convergence Adjustment

1. Color Purity Adjustment

NOTE: Before attempting any purity adjustments, the receiver should be operated for at least fifteen minutes.

- (a) Demagnetize the picture tube and cabinet using a degaussing coil.
- (b) Turn the Contrast and Brightness controls to maximum.
- (c) Adjust Red (VR503) and Blue (VR505) controls; to provide only a green raster. Advance the Green Bias control (VR504) if necessary.
- (d) Loosen the clamp screw holding the yoke backward to provide vertical green vertical green belt (Zone) in the picture screen.
- (e) Remove the Rubber Wedges.
- (f) Rotate and spread the tabs of the purity magnet (see Fig. 16) around the neck of the picture tube until the green belt is in centre of the screen. At the same time, centre the raster vertically.
- (g) Move the yoke slowly forward or backward until a uniform green screen is obtained. Tighten the clamp screw of the yoke temporarily.
- (h) Check the purity of the red and blue raster by adjusting the Bias controls.
- (i) Obtain a white raster, referring to white balance adjustment.
- (j) Proceed with convergence adjustment.

2. Convergence Magnet Assembly Positioning

Convergence Magnet Assembly and Rubber Wedges need mechanical positioning following Fig. 15

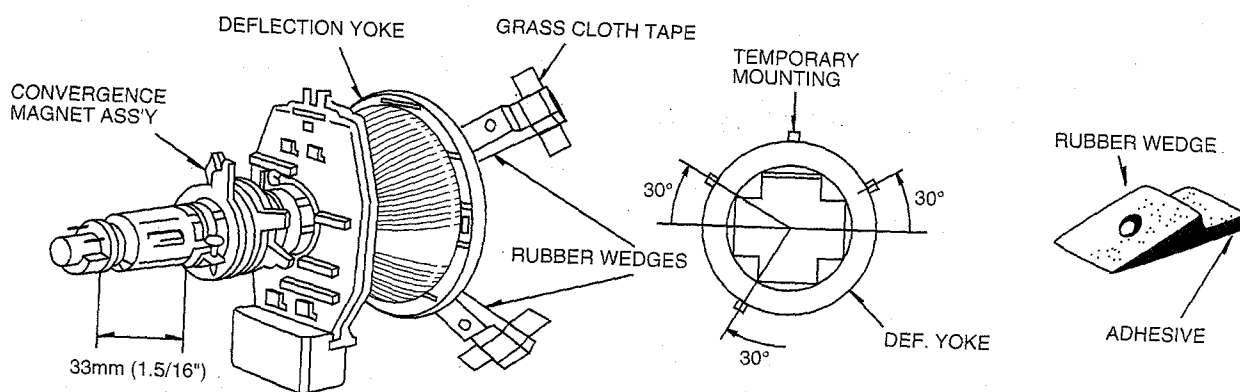

Fig. 15 RUBBER WEDGES LOCATION

3. Centre Convergence Adjustment

NOTE: Before attempting any convergence adjustments, the receiver should be operated for at least fifteen minutes:

- (a) Receive crosshatch pattern with a color bar signal generator.
- (b) Adjust the Brightness and Contrast controls for well defined pattern.
- (c) Adjust two tabs of the 4 Pole Magnets to change the angle between them (see Fig 16) and superimpose red and blue vertical lines in the centre area of the picture screen. (See Fig. 17)
- (d) Turn both tabs of the 4 Pole Magnets to change the angle to superimpose red and blue horizontal lines at the centre of screen (See Fig. 17).
- (f) Repeat adjustments 3,4,5, keeping in mind red, green and blue movement, because 4 Pole Magnets and 6 Pole Magnets interact and make dot movement complex.

4. Circumference Convergence Adjustment

NOTE: This adjustment requires Rubber Wedges and Glass Cloth Tapes.

- (a) Loosen the clamping screws of deflection yoke to allow the yoke to tilt.
- (b) Place a wedge as shown in Figure 6 temporarily. (Do not remove cover paper on adhesive part of the wedge).
- (c) Tilt front of the deflection yoke up or down to obtain better convergence in circumference. Push the mounted wedge into the space between picture tube and the yoke to hold the yoke temporarily.
- (d) Place other wedge into bottom space and remove the cover paper to stick.
- (e) Tilt front of the yoke right or left obtain better convergence in circumference.
- (f) Hold the yoke position and put another wedge in either upper space. Remove cover paper and stick the wedge on picture tube to hold the yoke.
- (g) Detach the temporarily mounted wedge and put it in another upper space. Stick it on picture tube to fix the yoke.
- (h) After placing three wedges, recheck over all convergence. Tighten the screw firmly to hold the yoke tightly in place.
- (i) Stick 3 glass cloth tapes on wedges as shown in Figure 15.

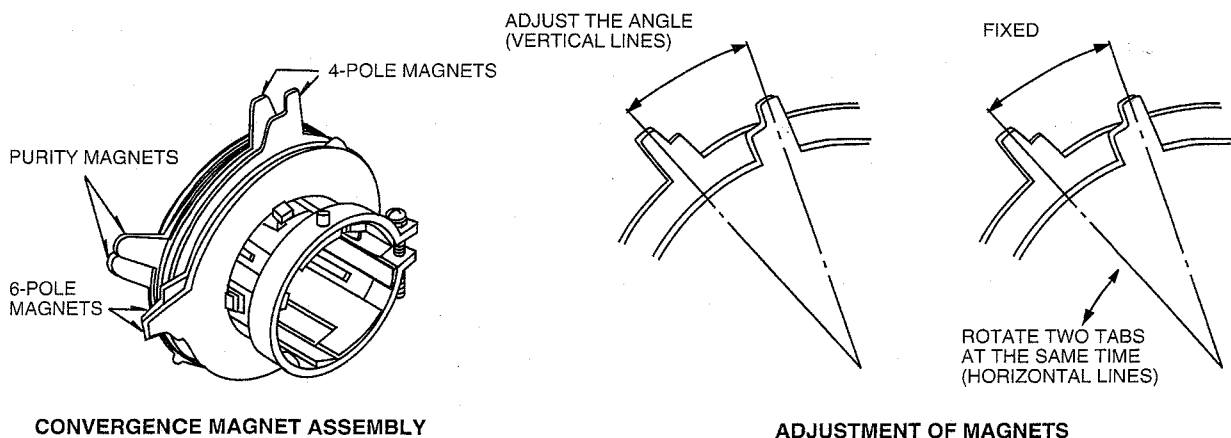

Fig. 16

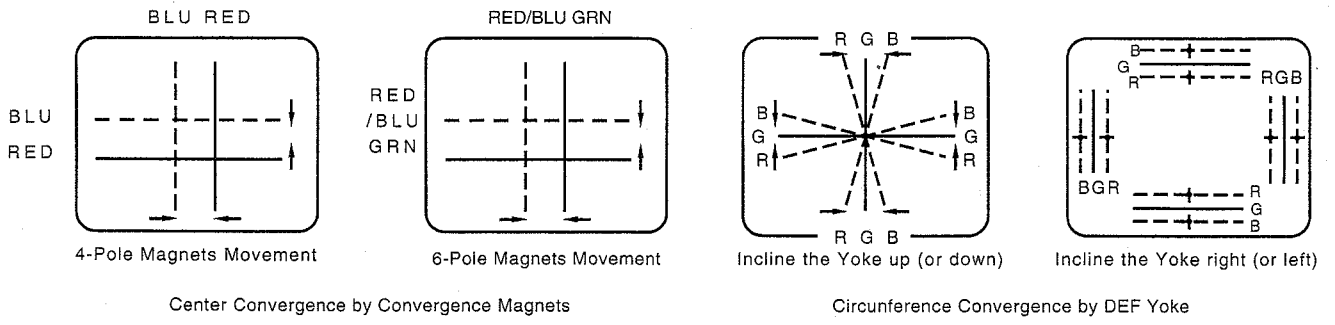
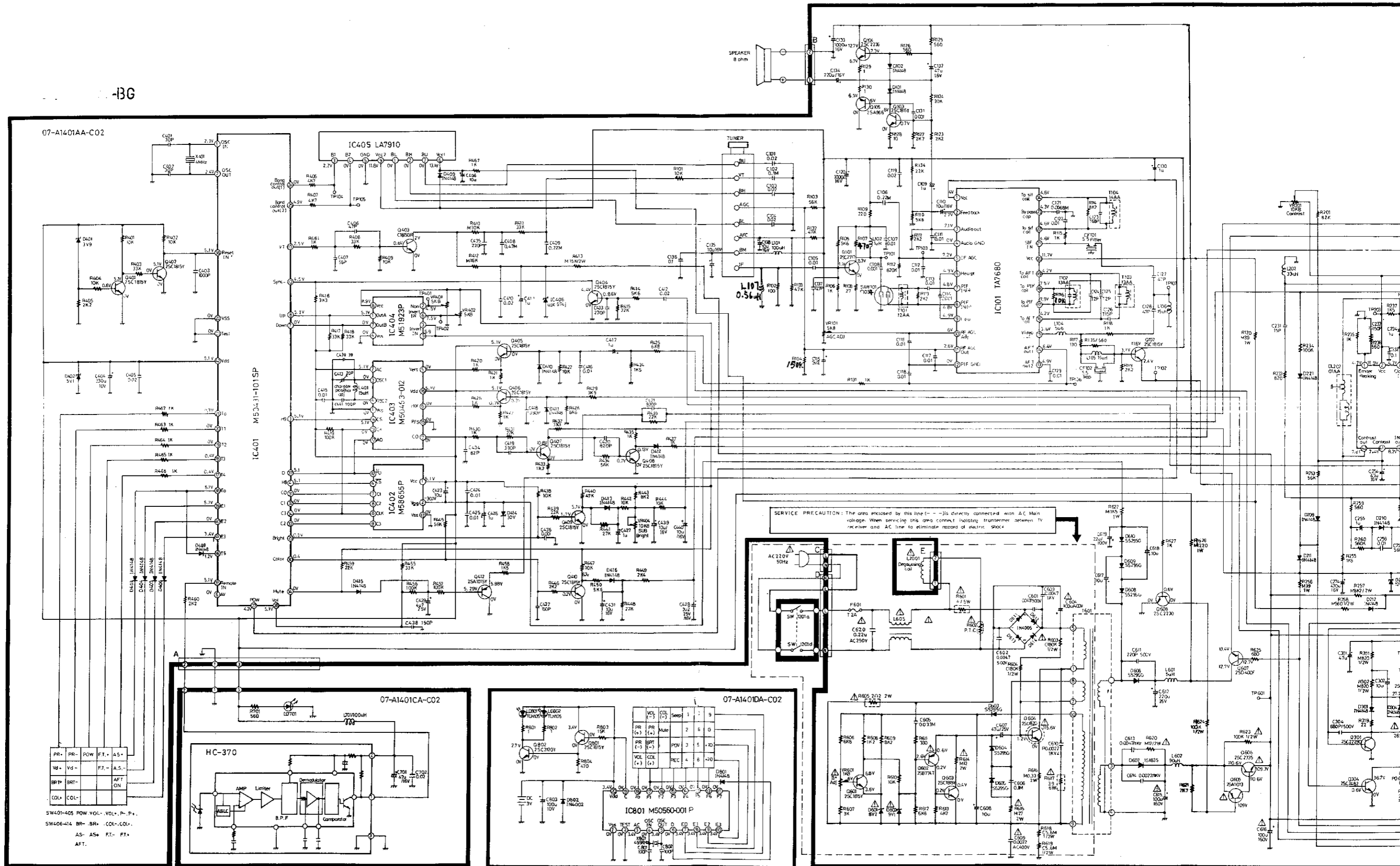
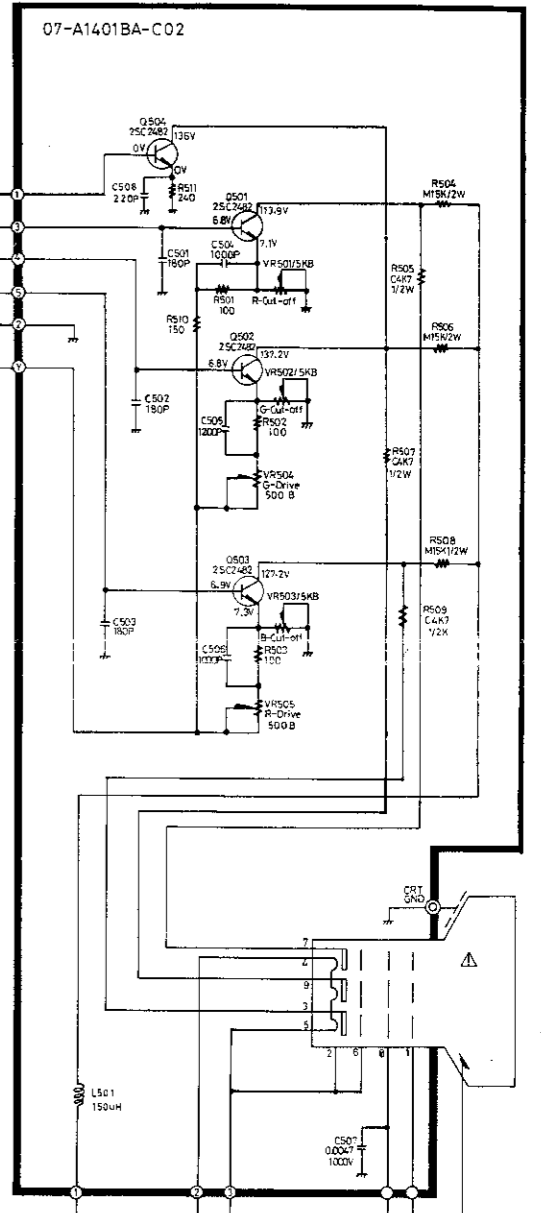
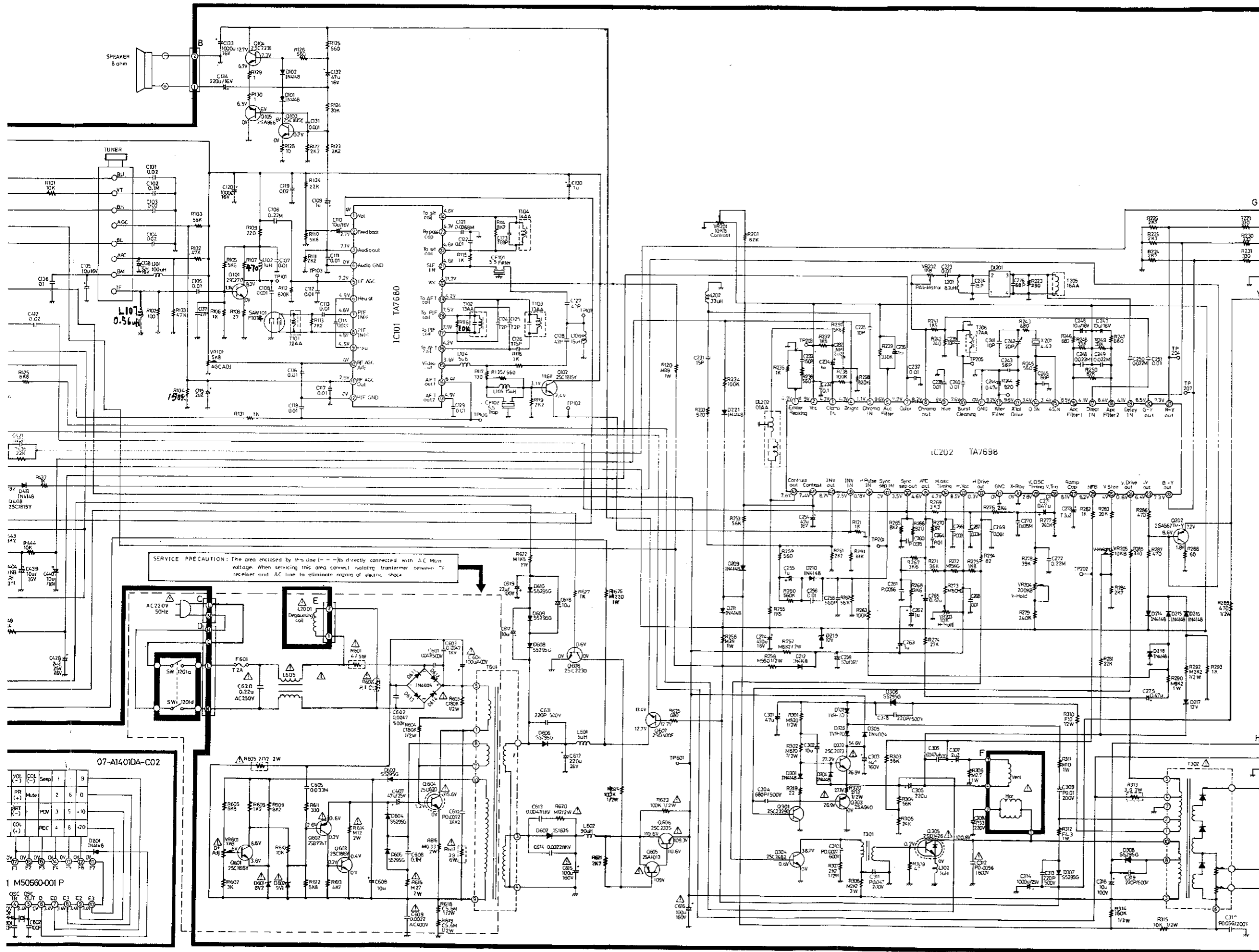

Fig.17 Dot Movement Pattern

-BG





BLOCK DIAGRAM

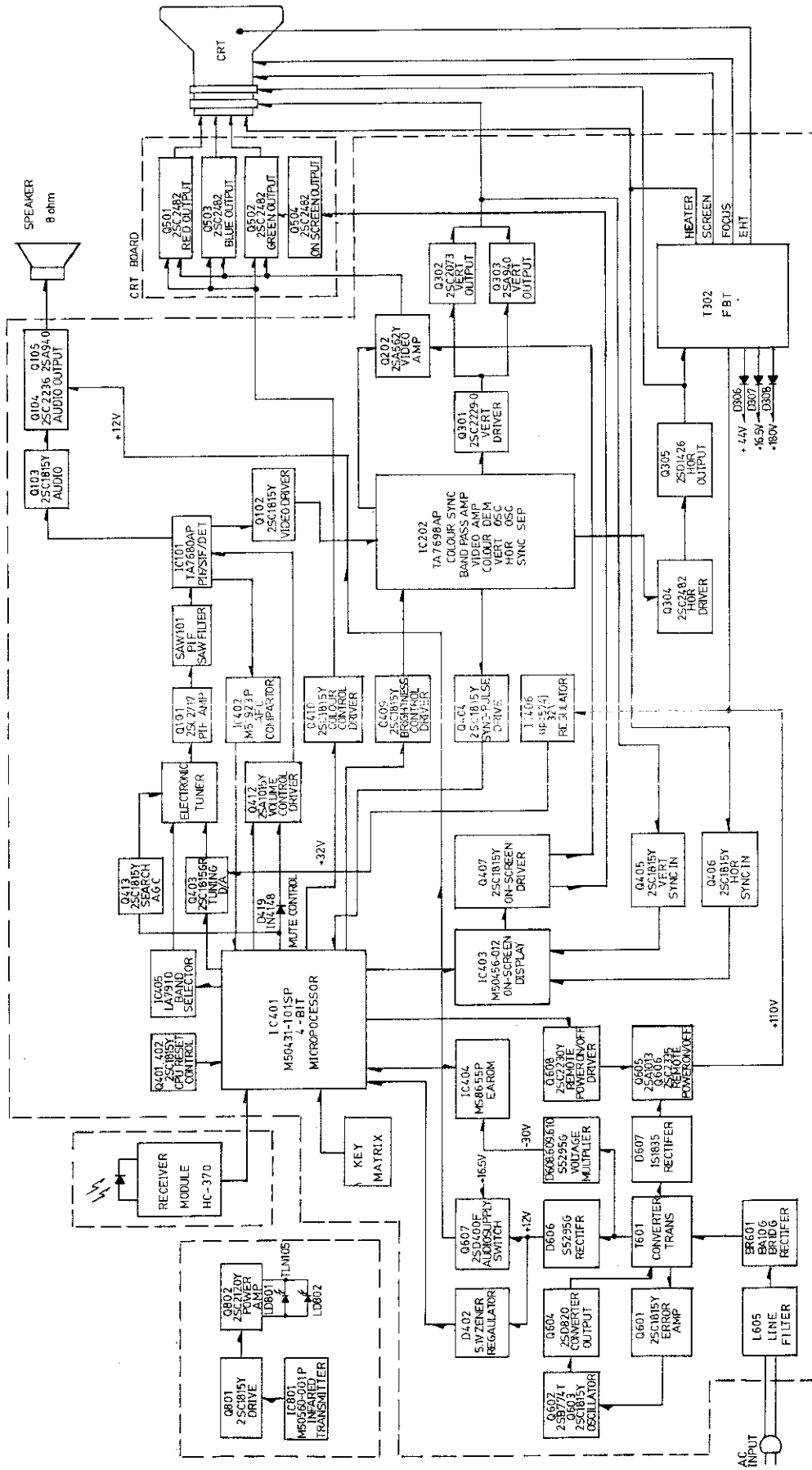

COMPONENT LAYOUT OF MAIN P. C. BOARD

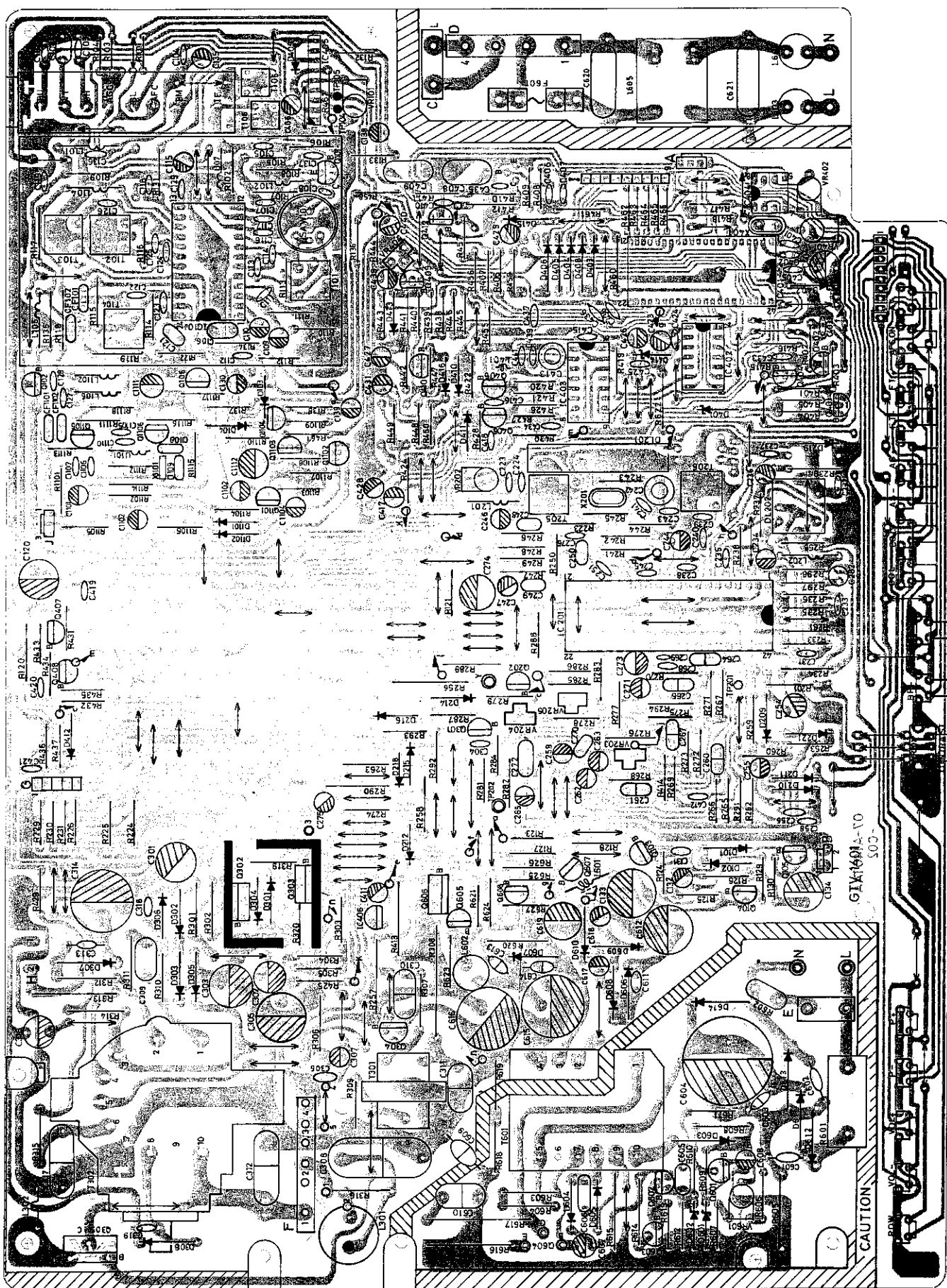

BOTTOM VIEW OF MAIN P. C. BOARD

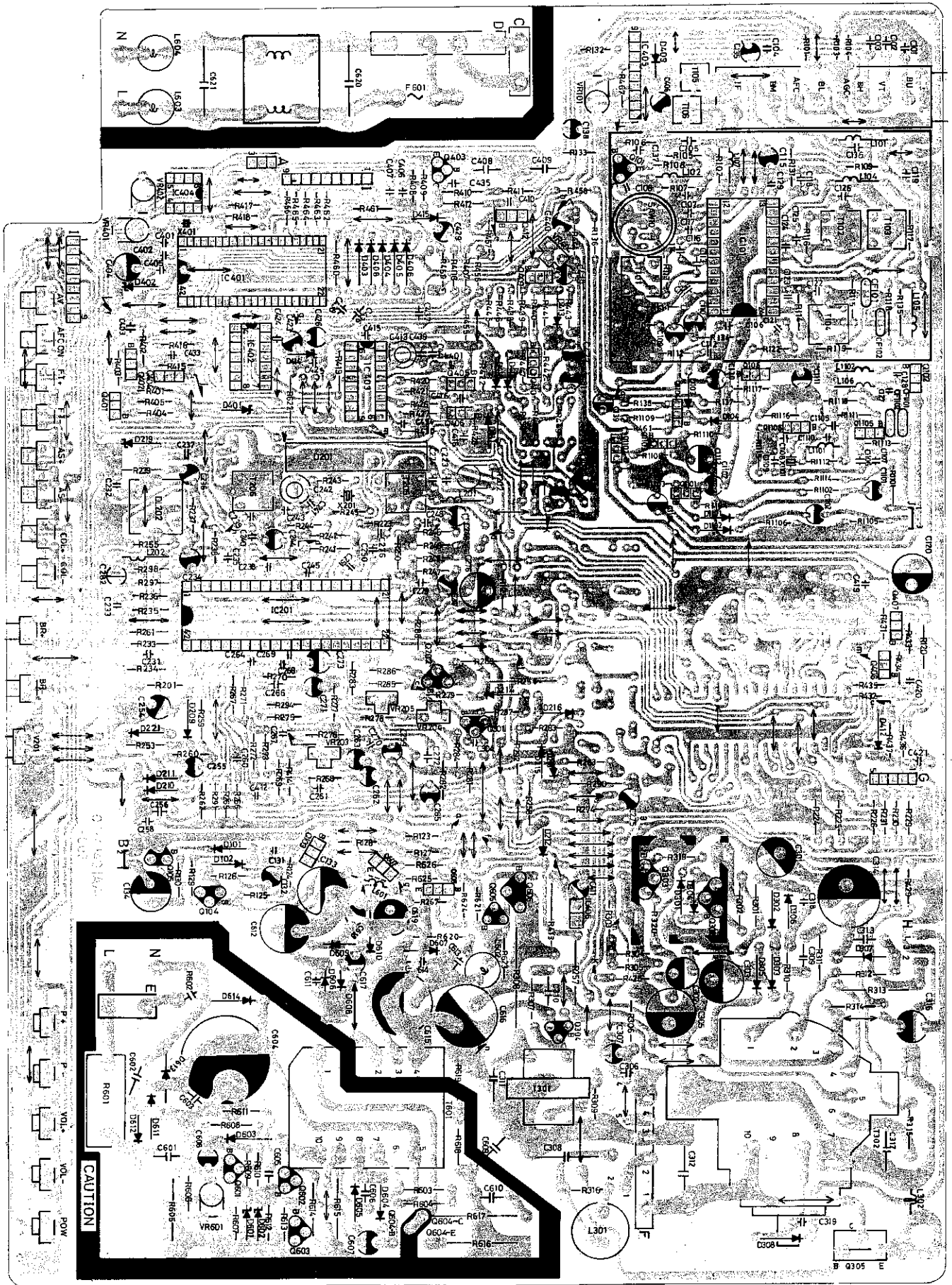

COMPONENT VIEW OF HAND SET PCB LAYOUT

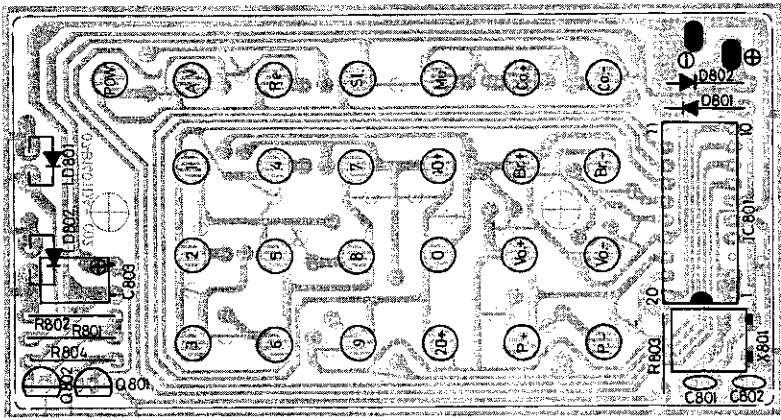

COMPONENT VIEW OF RECEIVER P.C.B

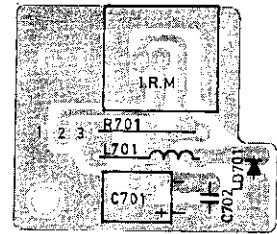

COMPONENT LAYOUT OF CRT P.C.B

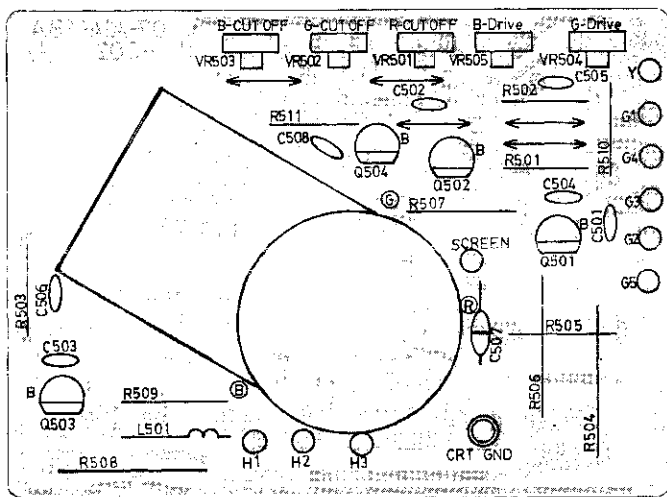

BOTTOM VIEW OF CRT P.C.B

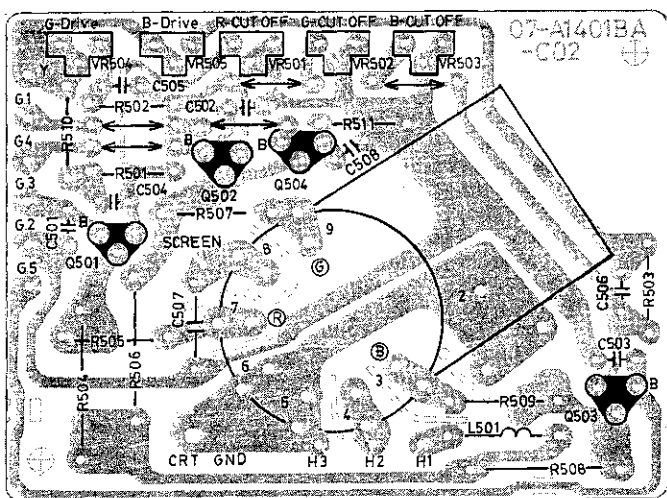

EXPLODED VIEW OF REMOTE CONTROL UNIT

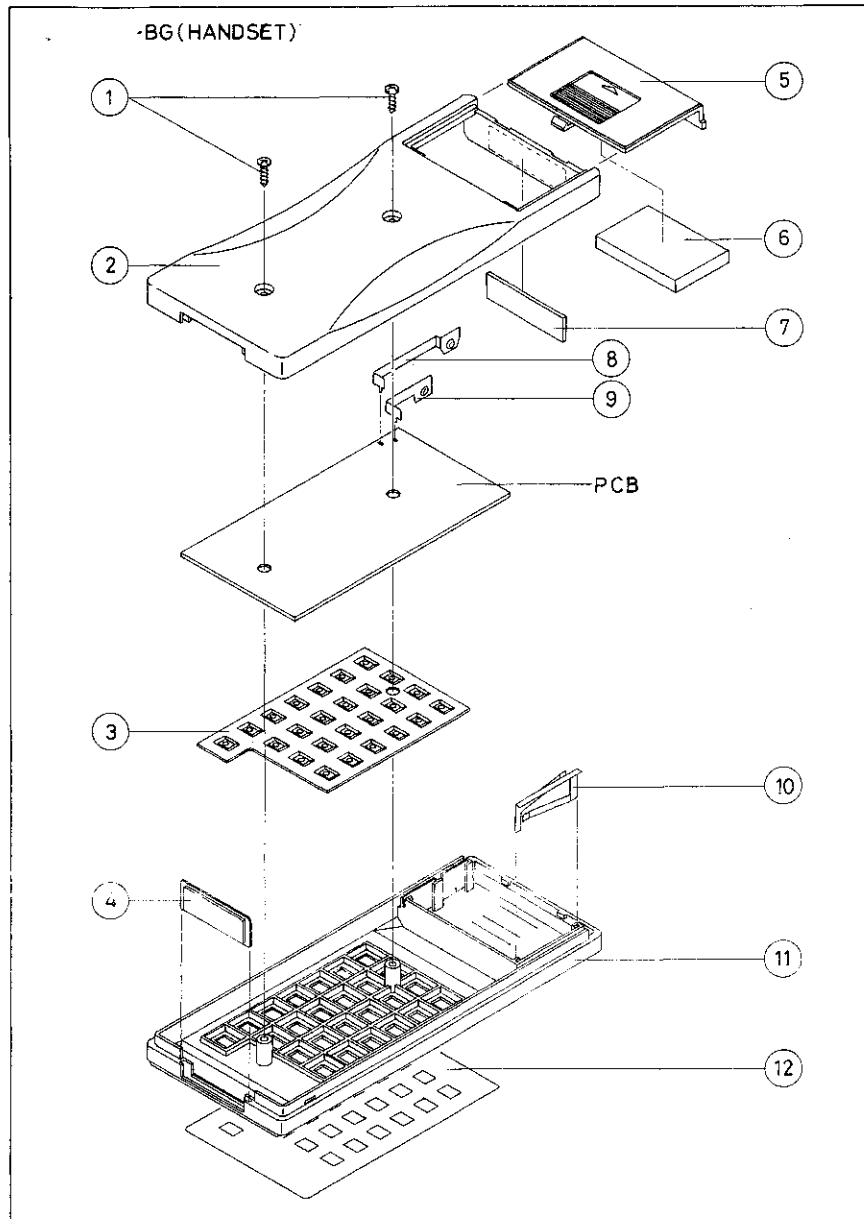

MECHANICAL PARTS LIST FOR REMOTE CONTROL UNIT

ITEM NO.	PART NO.	DESCRIPTION
1	64-PBT2601-N10	T2.6 X 10
2	52-AA00011-01A	HANDSET BOTTOM
3	55-AA00001-01A	RUBBER CONTACT
4	52-AA00013-00A	HANDSET LENS
5	52-AA00012-01A	BATTTERY DOOR
6	55-AA0003-00A	SPONGE
7	55-AA0002-00A	RUBBER FOAM
8	69-AA00003-00A	BATTERY CONTACT (-)
9	69-AA00002-00A	BATTERY CONTACT (+)
10	69-AA00004-00A	BATTERY CONTACT (+,-)
11	52-AA00010-01A	HANDSET TOP
12	54-AA00001-01A	HANDSET OVERLAY (24 KEYS)

EXPLODED VIEW OF MAIN UNIT

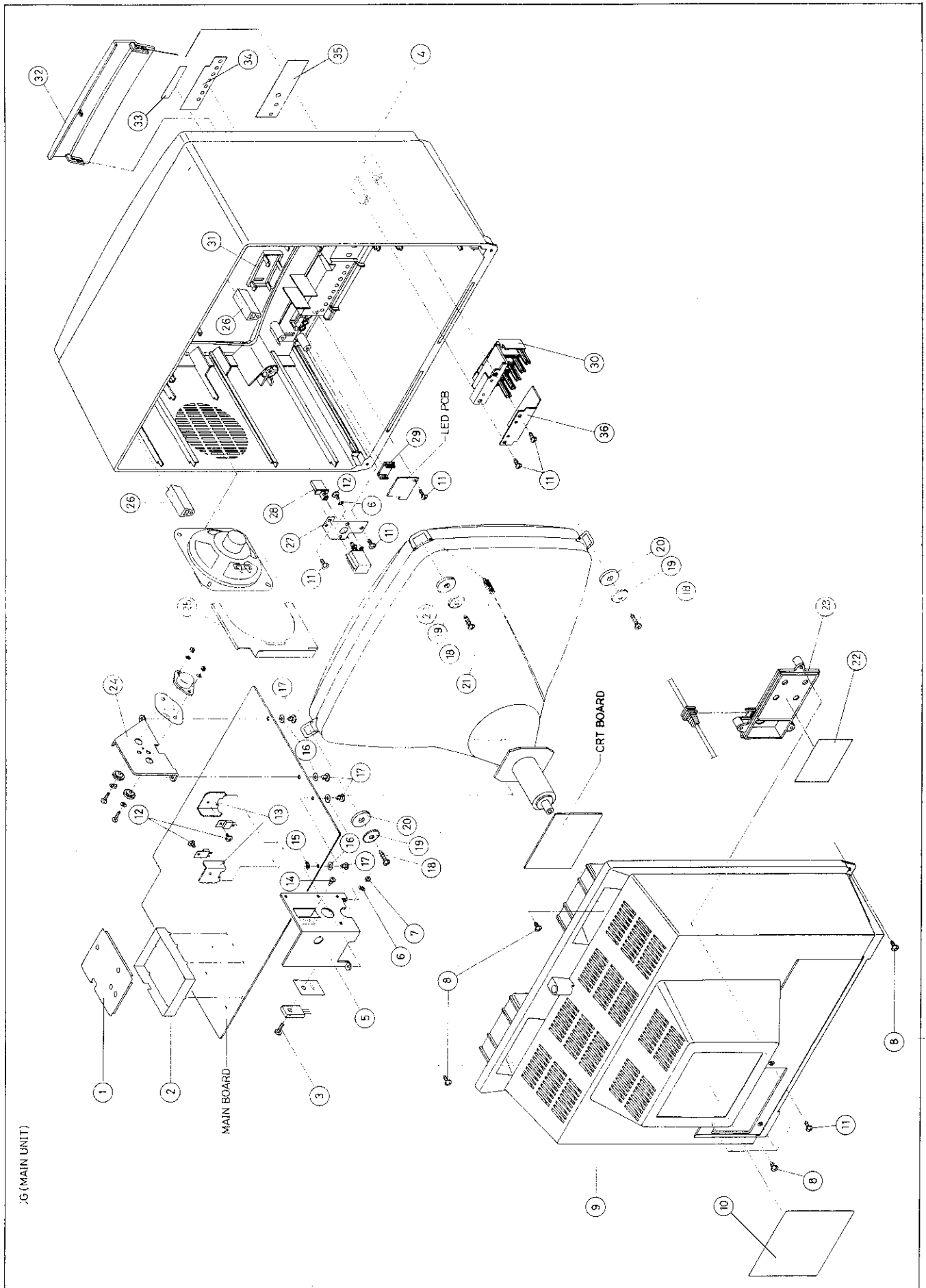

:G (MAIN UNIT)

MECHANICAL PARTS LIST FOR REMOTE CONTROL UNIT

ITEM NO.	PART NO.	DESCRIPTION
1	68-AA00002-00A	SHIELDING COVER
2	68-AA00001-00A	SHIELDING CAN
3	64-PBM3001-N12	M3 X 0.5 X 12
4	52-AA00001-01A	CABINET FRONT
5	67-AA00001-00A	HEAT SINK-HORIZONTAL
6	63-AAS3005-BC2	D3 SPRING WASHER
7	65-CHM3050-225	M3 NUT
8	64-PBT3501-N12	T3.5 X 12
9	52-AA00002-00A	CABINET BACK
10	54-AA00002-01A	BACK PLATE
11	64-PBT3001-N12	T3 X 12
12	64-PBM3001-N05	M3 X 0.5 X 5
13	67-AA00003-00A	HEAT SINK
14	64-PBT3501-N10	T3.5 X 10
15	27-04004CA-K02	SOLDERING LUG
16	63-AAP3008-DF0	FIBRE WASHER 3 X 8 X 0.8
17	64-PBT3001-N08	T3 X 8
18	64-PBT4001-N20	T4 X 20
19	69-AA00005-00A	CRT WASHER
20	63-AAP6022-KR0	RUBBER WASHER
21	57-AA00001-01A	SPRING
22	54-AA00003-00A	JACK PLATE INLAY
23	52-AA00006-00A	JACK PLATE
24	67-AA00002-00A	HEAT SINK-POWER
25	69-AA00001-00A	SPEAKER HOLDER
26	52-AA00008-00A	BOSS
27	66-AA00001-00A	POWER SWITCH BRACKET
28	52-AA00005-00A	POWER KNOB
29	52-AA00009-00A	INFRARED LENS
30	52-AA00004-01A	CONTROL KNOB
31	52-AA00007-01A	LENS
32	52-AA00003-01A	PRESET DOOR
33	54-AA00006-01A	NAME PLATE
34	54-AA00005-01A	CONTROL INLAY 'B'
35	54-AA00004-01A	CONTROL INLAY 'A'
36	66-AA00003-00A	CONTROL KNOB STOPPER

WARNING: BEFORE SERVICING THIS CHASSIS, READ THE "X-RAY RADIATION PRECAUTION", SAFETY PRECAUTION" AND "PRODUCT SAFETY NOTICE" ON PAGE 2 OF THIS MANUAL.

CAUTION: The areas marks Δ in the schematic diagram and the parts list designate components which have special characteristics important for safety and should be replaced only with types identical to those in the original circuit or specified in the parts list. Before replacing any of these components read carefully the PRODUCT SAFETY NOTICE on page 2. Do not degrade the safety of the receiver through improper servicing.

ABBREVIATIONS

Resistors: CF – Carbon Film Resistor
 CC – Carbon Composition Resistor
 MF – Metal Oxide Resistor
 MO – Metal Oxide Resistor
 FU – Fusible Resistor
 NI – Non-inflammable Resistor
 SF – Semi-fixed Resistor

Wire: SJ – Single Jumper Wire AWG 22 (UL1007)
 STJ – Strand Jumper Wire AWG 22 (UL1007)
 ST – Strand Jumper Wire AWG 24 (UL1007)
 STW – Strand Jumper Wire AWG 26 (UL1007)
 STX – Strand Jumper Wire AWG 22 (UL1015)

Capacitors: CE – Ceramic Capacitor
 PO – Polyester Film Capacitor
 PP – Polypropylene Film Capacitor
 EL – Electrolytic Capacitor
 TC – Temperature Compensating Capacitor
 MP – Metal Polyester Film Capacitor
 AC – AC Capacitor
 NP – Non-polar Electrolytic capacitor

Remark:
 1) All resistor are 1/4W, $\pm 5\%$ unless otherwise noted.
 2) All Capacitors are 50WV capacitor unless otherwise noted.

ELECTRICAL PARTS LIST

SYMBOL NO.	PART NO.	DESCRIPTION	SYMBOL NO.	PART NO.	DESCRIPTION
RESISTOR			RESISTOR		
R101	04-A104DCA-U01	CF10K OHM	R134	04-A224DCA-U01	CF22K OHM
R102	04-A102DCA-U01	CF100 OHM	R135	04-A562DCA-U01	CF560 OHM
R103	04-A564DCA-U01	CF56K OHM	R201	04-A824DCA-U01	CF82K OHM
R104	04-A125DCA-U01	CF120K OHM	R223	04-A392DCA-U01	CF390 OHM
R105	04-A563DCA-U01	CF5.6K OHM	R224	04-A273DCA-U01	CF2.7K OHM
R106	04-A103DCA-U01	CF1K OHM	R225	04-A273DCA-U01	CF2.7K OHM
R107	04-A472DCA-U01	CF470 OHM	R226	04-A273DCA-U01	CF2.7K OHM
R108	04-A271DCA-U01	CF27 OHM	R229	04-A332DCA-U01	CF330 OHM
R109	04-A222DCA-U01	CF220 OHM	R230	04-A332DCA-U01	CF330 OHM
R110	04-A563DCA-U01	CF5.6K OHM	R231	04-A332DCA-U01	CF330 OHM
R111	04-A223DCA-U01	CF2.2K OHM	R233	04-A822DCA-U01	CF820 OHM
R112	04-A825DCA-U01	CF820K OHM	R234	04-A105DCA-U01	CF100K OHM
R113	04-A223DCA-U01	CF2.2K OHM	R235	04-A103DCA-U01	CF1K OHM
R114	04-A823DCA-U01	CF8.2K OHM	R236	04-A562DCA-U01	CF560 OHM
R115	04-A103DCA-U01	CF1K OHM	R237	04-A153DCA-U01	CF1.5K OHM
R116	04-A223DCA-U01	CF2.2K OHM	R238	04-A105DCA-U01	CF100K OHM
R117	04-A332DCA-U01	CF330 OHM	R239	04-A335DCA-U01	CF330K OHM
R118	04-A103DCA-U01	CF1K OHM	R240		
R119	04-A223DCA-U01	CF2.2K OHM	R241	04-A153DCA-U01	CF1.5K OHM
R120	04-D391GCA-T08	MO39 OHM 1W	R242	04-A242DCA-U01	CF240 OHM
R121	04-A103DCA-U01	CF1K OHM	R243	04-A682DCA-U01	CF 680 OHM
R122			R244	04-A822DCA-U01	CF820 OHM
R123	04-A223DCA-U01	CF2.2K OHM	R245	04-A562DCA-U01	CF560 OHM
R124	04-A204DCA-U01	CF20K OHM	R246	04-A682DCA-U01	CF680 OHM
R125	04-A562DCA-U01	CF560 OHM	R247	04-A682DCA-U01	CF680 OHM
R126	04-A562DCA-U01	CF560 OHM	R248	04-A334DCA-U01	CF33K OHM
R127	04-A273DCA-U01	CF2.7K OHM	R249	04-A334DCA-U01	CF33K OHM
R128	04-A101DCA-U01	CF1 O OHM	R250	04-A824DCA-U01	CF82K OHM
R129	04-A100DCA-U01	CF1 OHM	R251		
R130	04-A100DCA-U01	CF1 OHM	R252		
R131	04-A103DCA-U01	CF 1K OHM	R253	04-A564DCA-U01	CF56K OHM
R132	04-A474DCA-U01	CF47K OHM	R254		
R133	04-A474DCA-U01	CF47K OHM	R255	04-A153DCA-U01	CF1.5KOHM

SYMBOL NO.	PART NO.	DESCRIPTION
RESISTOR		
R256	04-D391GCA-T08	MO390HM 1W
R257	04-D823HCA-T08	MO8.2 OHM 2W
R258	04-D562FCA-T08	MO560 OHM 1/2W
R259	04-A562DCA-U01	CF560 OHM
R260	04-A565DCA-U01	CF560K OHM
R261	04-A223DCA-U01	CF2.2K OHM
R262	04-A564DCA-U01	CF 56K OHM
R263	04-A105DCA-U01	CF100K OHM
R264		
R265	04-A823DCA-U01	CF8.2K OHM
R266	04-A822DCA-U01	CF820 OHM
R267	04-A363DCA-U01	CF3.6K OHM
R268	04-A363DCA-U01	CF3.6K OHM
R269	04-A333DCA-U01	CF3.3K OHM
R270	04-A821DCA-U01	CF82 OHM
R271	04-A364DCA-U01	CF36K OHM
R272	04-C154DAA-T08	MF15K OHM
R273	04-C155DAA-T08	MF150K OHM
R274	04-A274DCA-U01	CF27K OHM
R275	04-A183DCA-U01	CF1.8K OHM
R276	04-A243DCA-U01	CF2.4K OHM
R277	04-A245DCA-U01	CF240K OHM
R278	04-A394DCA-U01	CF 39K OHM
R279	04-A245DCA-U01	CF240K OHM
R280		
R281	04-A224DCA-U01	CF22K OHM
R282	04-A103DCA-U01	CF1K OHM
R283	04-A204DCA-U01	CF20K OHM
R284	04-A273DCA-U01	CF2.7K OHM
R285	04-A332DCA-U01	CF330 OHM
R286	04-A472DCA-U01	CF470 OHM
R287	04-A472DCA-U01	CF470 OHM
R288	04-A681DCA-U01	CF68 OHM
R289	04-A472FCA-U01	CF470 OHM 1/2W
R290	04-D823FCA-T08	MO8.2K OHM 1/2W
R291	04-A334DCA-U01	CF33K OHM
R292	04-D223FCA-T08	MO2.2K OHM 1/2W
R293	04-A123DCA-U01	CF1.2K OHM
R294	04-A821DCA-U01	CF82 OHM
R295		
R296		
R297	04-A563DCA-U01	CF5.6K OHM
R298	04-A825DCA-U01	CF820K OHM
R299		
R300		
R301	04-D822FCA-T08	MO820 OHM 1/2W
R302	04-D822FCA-T08	MO820 OHM 1/2W
R303	04-A564DCA-U01	CF56K OHM
R304	04-A564DCA-U01	CF56K OHM
R305	04-A244DCA-U01	CF24K OHM
R306	04-D270GCA-T08	MO2.7 OHM 1W
R307	04-A273FCA-U01	CF2.7K OHM 1/2W
R308	04-D223ICA-T08	MO2.2K OHM 3W

SYMBOL NO.	PART NO.	DESCRIPTION
RESISTOR		
R309	04-A471DCA-U01	CF47 OHM
R310	04-E101FCA-T08	FU10 OHM 1/2W
R311	04-D101GCA-T08	MO 10 OHM 1W
R312	04-E430GCA-T08	FU4.3 OHM 1W
R313	04G390HCA-T08	NI3.9 OHM 2W
R314	04-A185FCA-U01	CF180K OHM 1/2W
R315	04-A104FCA-U01	CF10K OHM 1/2W
R316		
R317		
R318		
R319	04-A221DCA-U01	CF22 OHM
R320	04-A220FCA-U01	CF2.2 OHM 1/2W
R401	04-A104DCA-U01	CF10K OHM
R402	04-A104DCA-U01	CF10K OHM
R403	04-A334DCA-U01	CF33K OHM
R404	04-A104DCA-U01	CF10K OHM
R405	04-A223DCA-U01	CF2.2K OHM
R406	04-A473DCA-U01	CF4.7K OHM
R407	04-A473DCA-U01	CF4.7K OHM
R408	04-A334DCA-U01	CF33K OHM
R409	04-A104DCA-U01	CF10K OHM
R410	04-C104DAA-T08	MF10K OHM
R411	04-A334DCA-U01	CF33K OHM
R412	04-C164DAA-T08	MF16K OHM
R413	04-D154HCA-T08	MO15K OHM 2W
R414	04-A563DCA-U01	CF5.6K OHM
R415	04-A224DCA-U01	CF22K OHM
R416	04-A333DCA-U01	CF3.3K OHM
R417	04-A334DCA-U01	CF33K OHM
R418	04-A334DCA-U01	CF33K OHM
R419	04-A105DCA-U01	CF100K OHM
R420	04-A103DCA-U01	CF1K OHM
R421	04-A103DCA-U01	CF1K OHM
R422	04-A104DCA-U01	CF10K OHM
R423		
R424	04-153DCA-U01	CF1.5K OHM
R425	04-A683DCA-U01	CF6.8K OHM
R426	04-A103DCA-U01	CF1K OHM
R427	04-A103DCA-U01	CF1K OHM
R428	04-A683DCA-U01	CF6.8K OHM
R429	04-A393DCA-U01	CF3.9K OHM
R430	04-A103DCA-U01	CF1K OHM
R431	04-A224DCA-U01	CF22K OHM
R432	04-A333DCA-U01	CF3.3K OHM
R433	04-A123DCA-U01	CF1.2K OHM
R434	04-A564DCA-U01	CF56K OHM
R435	04-A103DCA-U01	CF1K OHM
R436	04-A224DCA-U01	CF22K OHM
R437	04-A103DCA-U01	CF1K OHM
R438	04-A104DCA-U01	CF10K OHM
R439	04-A224DCA-U01	CF22K OHM
R440	04-A474DCA-U01	CF47K OHM
R441	04-A274DCA-U01	CF27K OHM

SYMBOL NO.	PART NO.	DESCRIPTION
RESISTOR		
R442	04-A104DCA-U01	CF10K OHM
R443	04-A823DCA-U01	CF8.2K OHM
R444	04-A104DCA-U01	CF10K OHM
R445	04-A564DCA-U01	CF56K OHM
R446	04-A223DCA-U01	CF2.2K OHM
R447	04-A104DCA-U01	CF10K OHM
R448	04-A224DCA-U01	CF22K OHM
R449	04-A243DCA-U01	CF2.4K OHM
R450	04-A563DCA-U01	CF5.6K OHM
R451		
R452		
R453		
R454		
R455	04-A334DCA-U01	CF33K OHM
R456	04-A105DCA-U01	CF100K OHM
R457	04-A105DCA-U01	CF100K OHM
R458	04-A153DCA-U01	CF1.5K OHM
R459	04-A224DCA-U01	CF22K OHM
R460	04-A223DCA-U01	CF2.2K OHM
R461	04-A103DCA-U01	CF1K OHM
R462	04-A103DCA-U01	CF1K OHM
R463	04-A103DCA-U01	CF1K OHM
R464	04-A103DCA-U01	CF1K OHM
R465	04-A103DCA-U01	CF1K OHM
R466	04-A103DCA-U01	CF1K OHM
R467	04-A103DCA-U01	CF1K OHM
R498		
R499		
R500		
R501	104-A102DCA-U01	CF100 OHM
R502	104-A102DCA-U01	CF100 OHM
R503	104-A102DCA-U01	CF100 OHM
R504	04-D154HCA-U01	MO 15K OHM 2W
R505	04-B473FCA-U01	CC4.7K OHM
R506	04-D154HCA-U01	MO15K OHM 2W
R507	04-B473FCA-U01	CC4.7K OHM
R508	04-D154HCA-U01	MO15K OHM 2W
R509	04-B473FCAU01	CF150 OHM
R510	04-A152DCA-U01	CF150 OHM
R511	04-A242DCA-U01	CF240 OHM
R601	04-G400KCA-T08	NI 4 OHM 5W
R602	04-H30IZFA-N02	P.T.C. THERMISTOR
R603	04-B185FCA-U01	CC180K OHM 1/2W
R604	04-B185FCA-U01	CC180K OHM 1/2W
R605	04-G220HCA-T08	NI2.2 OHM 2W
R606	04-A683DCA-U01	CF6.8K OHM
R607	04-A273DCA-U01	CF2.7K OHM
R608	04-A123DCA-U01	CF1.2K OHM
R609	04-A823DCA-U01	CF8.2K OHM
R610	04-A104DCA-U01	CF10 K OHM
R611	04-A332DCA-U01	CF330 OHM
R612	04-A683DCA-U01	CF6.8K OHM
R613	04-A473DCA-U01	CF4.7K OHM

SYMBOL NO.	PART NO.	DESCRIPTION
RESISTOR		
R614	04-D121HCA-T08	MO12 OHM 2W
R615	04-D271HCA-T08	MO27 OHM 2W
R616	04-D033HCA-T08	MO0.33 OHM 2W
R617	04-G391LCA-T08	NI 39 OHM 6W
R618	04-B185FCA-U01	CC5.6K OHM 1/2W
R619	04-B185FCA-U01	CC5.6K OHM 1/2W
R620	04-D121HCA-T08	MO12 OHM 2W
R621	04-A273DCA-U01	CF2.7K OHM
R622	04-D153GCA-T08	MO1.5K OHM 1W
R623	04-A105FCA-U01	CF100K OHM 1/2W
R624	04-A105FCA-U01	CF100K OHM 1/2W
R625	04-A682DCA-U01	CF680 OHM
R626	04-D222GCA-T08	MO 220 OHM 1W
R627	04-A103DCA-U01	CF1K OHM
R701	04-A562DCA-U01	CF560 OHM
R801	04-A100DCA-U01	CF1 OHM
R802	04-A100DCA-U01	CF1 OHM
R803	04-A154DCA-U01	CF15K OHM
R804	04-A472DCA-U01	CF470 OHM
VARIABLE RESISTOR		
VR101	03-A50302A-M03	SF5KB AGC,AFC COMPARATOR
VR201	03-B10401A-P01	SF10KB,CONTRAST
VR202	03-A10302A-M03	SF1KB PAL-MATRIX
VR203	03-B10402A-M03	SF10KB H-HOLD
VR204	03-B20502A-M03	SF200KB V-HOLD
VR205	03-B10402A-M03	SF10KB H-HOLD
VR401	03-A50302A-M03	SF5KB AGC,AFC
VR402	03-A50302A-M03	SF5KB AGC,AFC
VR403		
VR404	03-B10402A-M03	SF10KB H-HOLD
VR501	03-A50305B-M03	SF5K OHM B R/B/G CUT-OFF
VR502	03-A50305B-M03	SF5K OHM B R/B/G CUT-OFF
VR503	03-A50305B-M03	SF5K OHM B R/B/G CUT-OFF
VR504	03-A50205B-M03	SF500 OHM B B/G DRIVE
VR505	03-A50205B-M03	SF500 OHM B B/G DRIVE
VR601	03-A10302A-M03	SF1KB PAL-MATRIX
CAPACITORS		
C101	06-B203 FHA-M03	CF 0.02UF 50V +80 -20%
C102	06-C104 FDA-N02	PO 0.1UF 50V ±10%
C103	06-B203 FHA-M03	CE 0.02UF 50V +80 -20%
C104	06-B203 FHA-M03	CE 0.02UF 50V +80 -20%
C105	06-B103 FHA-M03	CE 0.01UF 50V +80 -20%
C106	06-C224FDA-N02	PO 0.22UF 50V ±10%
C107	06-B103FHA-M03	CE 0.01UF 50V +80 -20%
C108	06-B102FDA-M03	CE 0.001UF 50V ±10%
C109	06-A105FEA-N02	EL 1UF 50V ±20%
C110	06-A106CEA-N02	EL 10UF 16V ±20%
C111	06-B103FHA-M03	CE 0.01UF 50V +80 -20%
C112	06-B103FHA-M03	CE 0.01UF 50V +80 -20%

SYMBOL NO.	PART NO.	DESCRIPTION
CAPACITORS		
C113	06-B103FHA-M03	CE 0.01UF 50V +80 -20%
C114	06-B102FDA-M03	CE 0.001UF 50V ±10%
C115	06-A225FEA-N02	EL 2.2UF 50V ±20%
C116	06-B103FHA-M03	CE 0.01UF 50V +80 -20%
C117	06-B103FHA-M03	CE 0.01UF 50V +80 -20%
C118	06-B103FHA-M03	CE 0.01UF 50V +80 -20%
C119	06-B203FHA-M03	CE 0.02UF 50V +80 -20%
C120	06-A108CEA-N02	EL 1000UF 16V ±20%
C121	06-C682FDA-N02	PO 0.0068UF 50V ±10%
C122	06-B103FHA-M03	CE 0.01UF 50V +80 -20%
C123	06-J680FCA-M03	TC 68PF 50V ±5%
C124	06-J020FAA-M03	TC 2PF 50V ±0.25PF
C125	06-J020FAA-M03	TC 2PF 50V ±0.25PF
C126	06J150FCA-M03	TC 15PF 50V ±5%
C127	06-B470FCA-M03	CE 47PF 50V ±5%
C128	06-B470FCA-M03	CE 47PF 50V ±5%
C129	06-B103FHA-M03	CE 0.01UF 50V +80 -20%
C130	06-A105FEA-N02	EL 1UF 50V ±20%
C131	06-B102FDA-M03	CE 0.001UF 50V ±10%
C132	06-A476CEA-N02	EL 47UF 16V ±20%
C133	06-A108CEA-N02	EL 1000UF 16V ±20%
C134	06-A227CEA-N02	EL 220UF 16V ±20%
C135	06-A106CEA-N02	EL 10UF 16V ±20%
C136	06-B104FHA-M03	CE 0.1UF 50V +80 -20%
C137		
C138	06-A106CEA-N02	EL 10UF 16V ±20%
C223	06-B103FHA-M03	CE 0.01UF 50V +80 -20%
C224	06-B150FCA-M03	CE 15PF 50V ±5%
C225		
C226		
C227		
C228		
C229		
C230		
C231	06-B150FCA-M03	CE 15PF 50V ±5%
C232	06-B104FHA-M03	CE 0.1UF 50V +80 -20%
C233	06-B151FCA-M03	CE 150PF 50V ±5%
C234	06-A105FEA-N02	EL 1UF 50V ±20%
C235	06-B100FBA-M03	CE 10PF 50V ±0.5PF
C236	06-A105FEA-N02	EL 1UF 50V ±20%
C237	06-B103FHA-M03	CE 0.01UF 50V +80 -20%
C238	06-B103FHA-M03	CE 0.01UF 50V +80 -20%
C239	06-B330FCA-M03	CE 33PF 50V ±5%
C240	06-B103FHA-M03	CE 0.01UF 50V +80 -20%
C241	06-B100FBA-M03	CE 10PF 50V ±0.5PF
C242	05-A20002A-P02	TRIMMER 20PF
C243	06-B560FCA-M03	CE 56PF 50V ±5%
C244	06-A474FEA-N02	EL 0.47UF 50V ±20%
C245	06-B680FCA-M03	CE 68PF 50V ±5%
C246	06-A106CEA-N02	EL10UF16V ±20%
C247	06-A106CEA-N02	EL10UF16V ±20%

SYMBOL NO.	PART NO.	DESCRIPTION
CAPACITORS		
C248	06-C223FDA-N02	PO 0.022UF 50V ±10%
C249	06-C223FDA-N02	PO 0.022UF 50V ±10%
C250	06-C223FDA-N02	PO 0.022UF 50V ±10%
C251	06-B103FHA-M103	CE 0.01UF 50V +80 -20%
C252		
C252		
C253		
C254	06-A476CEA-N02	EL 47UF 16V ±20%
C255	06-A105FEA-N02	EL 1UF 50V ±20%
C256	06-B103FHA-M03	CE 0.01UF 50V +80 -20%
C257		
C258	06-B561FCA-M03	CE 560PF 50V ±5%
C259	06-A106CEA-N02	EL 10UF 16V ±20%
C260	06-C152GCA-T07	PO 0.0015UF 100V ±5%
C261	06-C562GCA-T07	PO 0.0056UF 100V ±5%
C262	06-A105FEA-N02	EL 1UF 50V ±20%
C263	06-A105FEA-N02	EL 1UF 50V ±20%
C264	06-C103GCA-T07	PO 0.01UF 100V ±5%
C265	06-A474FEA-N02	EL 0.47UF 50V ±20%
C266	06-C302GCA-T07	PO 0.003UF 100V ±5%
C267	06-C333FDA-N02	PO 0.033UF 50V±10%
C268	06-B103FHA-M03	CE 0.01UF 50V ±10%
C269	06-B102FDA-M03	CE 0.001UF 50V +80-20%
C270	06-C153FDA-N02	PO 0.015 UF 50V ±10%
C271	06-A474FEA-N02	EL 0.47 UF 50V ±20%
C272	06-C224FDA-N02	PO 0.22UF 50V ±10%
C273	06-A225FDA-N02	EL 2.2UF 50V ±10%
C274	06-A477CEA-N02	EL 470UF 16V ±20%
C275	06-A474 FEA-N02	EL 0.47UF 50V ±20%
C276	06-B680FCA-M03	CE 68PF 50V ±5%
C277		
C278		
C279		
C280		
C281		
C282	06-K225FEA-N02	NP 2.2UF 50V ±20%
C301	06-A476FEA-N02	EL47UF 50V ±20%
C302	06-A106FEA-N02	EL10UF 50V ±20%
C303	06-A475HEA-N02	EL 4.7UF 160V ±20%
C304	06-B681MDA-M03	CE 680PF 500V ±10%
C305	06-A227FEA-N02	EL 220UF 50V ±20%
C306	06-B472MDA-M03	CE 0.0047UF 500V ±10%
C307	06-A225FEA-N02	EL 2.2UF 50V ±20%
C308	06-D334ICA-P01	PP 0.33UF 200V ±5%
C309	06-C103ICA-T07	PO 0.01UF 200V ±5%
C310	06-D2220CA-P01	PP 0.0022UF 630V ±5%
C311	06-D473ICA-TO7	PP0.047UF 200V ±5%
C312	06-D562TCA-P01	PP 0.0056UF 1600V ±5%
C313	06-B221MDA-M03	CE 220PF 500V ±10%
C314	06-A108DEA-N02	EL1000UF 25V ±20%
C315		
C316	06-A106GEA-N02	EL10UF 100V ±20%
C317	06-D563ICA-T07	PP 0.056UF 200V ±5%

SYMBOL NO.	PART NO.	DESCRIPTION
CAPACITORS		
C318	06-B221MDA-M03	CE220PF 500V ±10%
C319	06-B221MDA-M03	CE220PF 500V ±10%
C401	06-B300FCA-M03	CE30PF 50V ±5%
C402	06-B300FCA-M03	CE30PF 50V ±5%
C403	06-B102FDA-M03	CE0.001UF 50V ±10%
C404	06-A337BEA-N02	EL330UF 10V ±20%
C405	06-B203FHA-M03	CE 0.02UF 50V +80 -20%
C406	06-B470FCA-M03	CE47PF 50V ±5%
C407	06-B560FCA-M03	CE56PF 50V ±5%
C408	06-C474FDA-N02	PO 0.47UF 50V ±10%
C409	06-C224FDA-N02	PO 0.22UF 50V ±10%
C410	06-B203FHA-M03	CE 0.02UF 50V +80 -20%
C411	06-A105FEA-N02	EL1UF 50V ±20%
C412	06-B203FHA-M03	CE 0.02UF 50V +80 -20%
C413	05-A20002A-PO2	TRIMMER 20PF
C414		
C415	06-B103FHA-M03	CE 0.01UF 50V +80 -20%
C416	06-B103FHA-M03	CE 0.01UF 50V +80 -20%
C417	06-A105FEA-N02	EL1UF 50V ±20%
C418	06-B391FCA-M03	CE390PF 50V ±5%
C419	06-B391FCA-M03	CE390PF 50V ±5%
C420	06-B821FCA-M03	CE820PF 50V ±5%
C421	06-B821FCA-M03	CE820PF 50V ±5%
C422		
C423	06-A106FEA-N02	EL10UF 50V ±20%
C424	06-B103FHA-N03	CE 0.01UF 50V +80 -20%
C425	06-B103FHA-N03	CE 0.01UF 50V +80 -20%
C426	06-A105FEA-N02	EL1UF 50V ±20%
C427	06-A105FEA-N02	EL1UF 50V ±20%
C428	06-A225DEA-N02	EL 2.2UF 25V ±20%
C429	06-A475DEA-N02	EL 4.7UF 25V±20%
C430		
C431	06-A106CEA-N02	EL10UF 16V ±20%
C432		
C433	06-B271FCA-M03	CEL 270PF 50V ±5%
C434	06B820FCA-M03	CE 82PF 50V± 5%
C435	06-B221FCA-M03	CE 220PF 50V ±5%
C436	06-B102FDA-M03	CE 0.001UF 50V ±10%
C437	06-B151FCA-M03	CE 150PF 50V ±5%
C438	06-B151FCA-M03	CE 150PF 50V ±5%
C439	06-A106CEA-N02	EL 10UF 16V ±20%
C440	06-A106CEA-N02	EL 10UF 16V ±20%
C441	06-B101FCA-N02	CE 100PF 50V ±5%
C489	06-B390FCA-M03	CE 39PF 50V ±5%
C490	06-A106FEA-N02	EL 10UF 50V ±20%
C501	06-B181FCA-M03	CE 180PF 50V ±5%
C502	06-B181FCA-M03	CE 180PF 50V ±5%
C503	06-B181FCA-M03	CE 180PF 50V ±5%
C504	06-B102FDA-M03	CE 0.001UF 50V ±10%
C505	06-B122FDA-M03	CE 0.0012UF 50V ±10%
C506	06-B102FDA-M03	CE 0.001UF 50V ±10%
C507	06-B472RDA-M03	CE 0.0047UF 1KV ±10%
C508	06-B221FCA-M03	CE 220PF 50V ±5%

SYMBOL NO.	PART NO.	DESCRIPTION
CAPACITORS		
C601	06-B472MDA-M03	CE 0.0047UF -500V ±10%
C602	06-B472MDA-M03	CE 0.0047UF -500V ±10%
C603	06-B472RDA-M03	CE0.0047UF 1KV ±10%
C604	06-A107 LEAN-02	EL100UF 400V ±20%
C605	06-C333FDAN02	PO0.033 UF 50V ±10%
C606	06-C104FDA-N02	PO 0.1UF 50V ±10%
C607	06-476DEA-N02	EL47UF 25V ±20%
C608	06-A106 FEAN02	EL10UF 50V ±20%
C609	06-F222XEA-M03	AC 0.0022UF AC400V ±20%
C610	06-D222SCA-P01	PP0.0022UF 1200V ± 5%
C611	06-B221MCA-M03	CE220-PF 500V ±10%
C612	06-A227DEA-N02	EL220UF 25V ±20%
C613	06-B472 RDA-M03	CE.0.0047UF 1KV ±10%
C614	06-B222RDA-M03	CE0.0022UF 1KV ±10%
C615	06-A107HEA-N02	EL100UF 160V ±20%
C616	06-A107HEA-N02	EL100UF 160V ±20%
C617	06-A106FEA-N02	EL10UF 50V ±20%
C618	06-A106FEA-N02	EL10UF 50V ±20%
C619	06-A226GEA-N01	EL 22UF 100V ±20%
C620	06-E224WEA-T06	MP 0.22UF AC 275V 20%
C621	06-E224WEA-T06	MP 0.22UF AC 275V ±20%
C701	06-A476CEA-N02	EL 47UF 16V ±20
C702	06-B203FHA-M03	CE 0.02UF 50V +80 -20%
C801	06-B101FCA-M03	CE 100PF 50V ±5%
C802	06-B101FCA-M03	CE 100PF 50V ±5%
C803	06-A107BDA-N02	EL100UF10V ±20%
D101	02-A00001A-T01	IN4148
D102	02-A00001A-T01	IN4148
D209	02-A00001A-T01	IN4148
D210	02-A00001A-T01	IN4148
D211	02-A00001A-T01	IN4148
D212	02-A00001A-T01	IN4148
D213		
D214	02-A00001A-T01	IN4148
D215	02-A00001A-T01	IN4148
D216	02-A00001A-T01	IN4148
D217		
D218	02-A00001A-T01	IN4148
D219	02-C00010A-T01	12V ZENER
D220		
D221	02-A00001A-T01	IN4148
D301	02-A00001A-T01	IN4148
D302	02-B00002A-T01	TVR-2D
D303	02-B00002A-T01	TVR-2D
D304	02-A00001A-T01	IN4148
D305	02-B00004A-T01	IN4004S
D306	02-B00003A-T01	S5295G
D307	02-B00003A-T01	S5295G
D308	02-B00003A-T01	S5295G
D401	02-C00006A-T01	3.9VZENER
D402	02-C00007A-T01	5.1V ZENER

SYMBOL NO.	PART NO.	DESCRIPTION
DIODE		
D403	02-A00001A-T01	IN4148
D404	02-A00001A-T01	IN4148
D405	02-A00001A-T01	IN4148
D406	02-A00001A-T01	IN4148
D407	02-A00001A-T01	IN4148
D408	02-A00001A-T01	IN4148
D409	02-A00001A-T01	IN4148
D410	02-A00001A-T01	IN4148
D411	02-A00001A-T01	IN4148
D412	02-A00001A-T01	IN4148
D413	02-A00001A-T01	IN4148
D414	02-C000011A-T01	30V ZENER
D415	02-A000001A-T01	IN4148
D416	02-A000001A-T01	IN4148
D601	02-C00008A-T01	8.2V ZENER
D602	02-C00009-T01	9.1V ZENER
D603	02-B00003A-T01	S5295G
D604	02-B00003A-T01	S5295G
D605	02-B00003A-T01	S5295G
D606	02-B00003A-T01	S5295G
D607	02-B00005A-T01	1S1835
D608	02-B00003A-T01	S5295G
D609	02-B00003A-T01	S5295G
D610	02-B00003A-T01	S5295G
D611	02-B00015A-M06	IN4005 1A 600V
D612	02-B00015A-M06	IN4005 1A 600V
D613	02-B00015A-M06	IN4005 1A 600V
D614	02-B00015A-M06	IN4005 1A 600V
D801	02-A00001A-T01	IN4148
D802	02-D00012A-T01	IN4002
LD801	02-D00013A-T01	TLN105
LD802	02-D00013A-T01	TLN105
TRANSISTOR		
Q101	01-C00003A-T01	2SC2717
Q102	01-C00001A-T01	2SC1815Y
Q103	01-C00001A-T01	2SC1815Y
Q104	01-C00009A-T01	2SC2236
Q105	01-A00010A-T01	2SA966
Q202	01-A00004A-T01	2SA562TM-Y
Q301	01-C00005A-T01	2SC2229-0
Q302	01-C00006A-T01	2SC2073
Q303	01-A00007A-T01	2SA940
Q304	01-C00008A-T01	2SC2482
Q305	01-D00011A-T01	2SD1426
Q401	01-C00001A-T01	2SC1815Y
Q402	01-C00001A-T01	2SC1815Y
Q403	01-C00002A-T01	2SC1815GR
Q404	01-C00001A-T01	2SC1815Y
Q405	01-C00001A-T01	2SC1815Y
Q406	01-C00001A-T01	2SC1815Y
Q407	01-C00001A-T01	2SC1815Y
Q408	01-C00001A-T01	2SC1815Y
Q409	01-C00001A-T01	2SC1815Y

SYMBOL NO.	PART NO.	DESCRIPTION
TRANSISTOR		
Q410	01-C00001A-T01	2SC1815Y
Q411		
Q412	01-A00012A-T01	2SA1015Y
Q501	01-C00008A-T01	2SC2482
Q502	01-C00008A-T01	2SC2482
Q503	01-C00008A-T01	2SC2482
Q504	01-C00008A-T01	2SC2482
Q601	01-C00001A-T01	2SC1815Y
Q602	01-B00016A-M02	2SB774T
Q603	01-C00001A-T01	2SC1815Y
Q604	01-D00013A-T01	2SD820
Q605	01-A00014A-T01	2SA1013
Q606	01-C00017A-N01	2SC2335
Q607	01-D00018A-S01	2SD400F
Q608	01-C00015A-T01	2SC2230AY
Q801	01-C00001A-T01	2SC1815Y
Q802	01-C00019A-T01	2SC2120Y
Coil		
L101	08-A0007AA-T02	PEAKING COIL 100UH
L102	08-A0002AA-T02	PEAKING COIL 1UH
L104	08-A0003AA-T02	PEAKING COIL 5.6UH
L105	08-A0005AA-T02	PEAKING COIL 15 UH
L106	08-A0005AA-T02	PEAKING COIL 15 UH
L107	08-A0020AA-T02	PEAKING COIL 0.56UH
L201	08-A0004AA-T02	PEAKING COIL 8.2UH
L202	08-A0006AA-T02	PEAKING COIL 33 UH
L302	08-B0009AA-T03	CHOKE COIL 1UH
L401	08-A0005AA-T02	PEAKING COIL 15 UH
L501	08-A0019AA-T02	PEAKING COIL 150 UH
L601	08-B0010AA-T03	CHOKE COIL 5UH
L602	08-B0011A-T03	CHOKE COIL 90UH
L605	08-F0021AA-T03	LINE FILTER
L701	08-A0007AA-T02	CHOKE COIL 100UH
L2001	08-H0023AA-N04	DEGAUSSING COIL
T101	08-J0012AA-C01	PIF MATCHING COIL
T102	08-J0013AA-C01	PIF/AFC DET. COIL
T103	08-J0013AA-C01	PIF/AFC DET. COIL
T104	08-J0014AA-C01	SIF DET. COIL
T205	08-J0016AA-C01	MATCHING COIL
T206	08-J0017AA-C01	BURST CLEANING COIL
TRANSFORMER		
T301	09-D0001AA-T03	HORIZONTAL DRIVE TRANSFORMER
T302	09-E0002AA-L01	FLYBACK TRANSFORMER
T601	09-F0003AA-T03	SWITCHING POWER TRANSFORMER
INTERGRATED CIRCUITS		
IC101	15-240001A-T01	TA7680AP
IC202	15-420002A-T01	TA7698AP
IC401	15-420003A-M04	M50431-101SP
IC402	15-140004A-M04	M58655P
IC403	15-180006A-M04	M50453-012P

SYMBOL NO.	PART NO.	DESCRIPTION
INTERGRATED CIRCUITS		
IC404	15-080006A-M04	M51923P
IC405	15-090007A-S01	LA7910
IC406	15-020008A-N01	UPC574J
IC801	15-200009A-M04	M50560-001P
PRINTED CIRCUIT BOARD(P.C.B.)		
PCB01	07-A1401AA-T05	Main P.C. BOARD
PCB02	07-A1401BA-T05	CRT P.C. BOARD
PCB03	07-A1401CA-T05	RECEIVER P.C. BOARD
PCB04	07-B1401DA-N03	TRANSMITTER P.C. BOARD
CONNECTOR ASS'Y		
Socket A	10-03003AA-T04	3 PINS WAFER
Socket B	10-03002AA-T04	2 PINS WAFER
Socket C	10-05002BA-T04	2 PINS WAFER
Socket D	10-05004BA-T04	4 PINS WAFER
Socket E	10-05002BA-T04	2 PINS WAFER
Socket F	10-04006AA-T04	6 PINS WAFER
Socket Y	10-01001EA-T04	1 PIN TERMINAL
CRT GND	10-08001EA-T04	TAIKO 1 PIN TERMINAL
ASSY L	25-010001A-T04	TAIKO CONNECTOR 1 PIN
ASSY N	25-010002A-T04	TAIKO CONNECTOR 1 PIN
Socket G	25-050003A-T04	TAIKO CONNECTOR 5 PINS
Socket Y	25-010004A-T04	TAIKO CONNECTOR 1 PIN (BROWN)
Socket A	25-030005A-T04	TAIKO CONNECTOR 3 PINS(BLUE)
Socket B	25-020006A-T04	TAIKO CONNECTOR 2 PINS
Socket D	25-040007A-T04	TAIKO CONNECTOR 4 PINS
CRT GND	25-010008A-T04	TAIKO CONNECTOR 1 PIN
JUMPER WIRE		
20-AA101DC-M05		SJ100MM RED N
20-AA141DE-M05		SJ140MM YELLOW J,K.
20-AA151DF-M05		SJ150MM GREEN A,C,H
20-AA800DG-M05		SJ80MM BLUE D
20-AA171DH-M05		SJ170MM VIOLET M
20-AA181DI-M05		SJ180MM GREY L.I.
20-AA201DJ-M05		SJ200MM WHITE E,F,G
20-BB500DA-M05		ST50MM BLACK Q604-E
20-BB600DB-M05		ST60MM BROWN Q604-B
20-KA700DC-M05		STX 70MM RED Q604-C
20-EC121DA-M005		STW120MM BLACK P=2.5MM
20-FA500AK-M05		BARE WIRE AWG22 L=50MM
20-BB331DC-M05		ST330MM RED H1
20-BB331DE-M05		ST330MM YELLOW H2
20-BB331DA-M05		ST330MM BLACK H3
20-MZ861AK-M05		TWISTED WIRE L=850MM
MISCELLANEOUS		
X201	13-A4434AA-I01	CRYSTAL 4.433 6178MHZ

SYMBOL NO.	PART NO.	DESCRIPTION
MISCELLANEOUS		
X401	13-R4004AA-M03	CERAMIC RESONATOR 4MHZ
X801	13-B4553AA-M03	CERAMIC RESONATOR 455KHZ
CF101	13-B5504AA-M03	CERAMIC FILTER 5.5MHZ
CF102	13-B5504AB-M03	CERAMIC TRAP 5.5 MHZ
SW401	11-B0001AA-P01	TACT SWITCH L=7MM
SW402	11-B0001AA-P01	TACT SWITCH L=7MM
SW403	11-B0001AA-P01	TACT SWITCH L=7MM
SW404	11-B0001AA-P01	TACT SWITCH L=7MM
SW405	11-B0001AA-P01	TACT SWITCH L=7MM
SW406	11-B0002AA-P01	TACT SWITCH L=13MM
SW407	11-B0001AA-P01	TACT SWITCH L=13MM
SW408	11-B0001AA-P01	TACT SWITCH L=13MM
SW409	11-B0001AA-P01	TACT SWITCH L=13MM
SW410	11-B0001AA-P01	TACT SWITCH L=13MM
SW411	11-B0001AA-P01	TACT SWITCH L=13MM
SW412	11-B0001AA-P01	TACT SWITCH L=13MM
SW413	11-B0001AA-P01	TACT SWITCH L=13MM
SW414	11-B0001AA-P01	TACT SWITCH L=13MM
SW2001	11-A0003EA-P01	POWER SWITCH
SAW101	17-010004A-T01	PIF SAW FILTER F1034
DL201	17-030002A-C01	ULTRASONIC DELAY LINE
DL202	08-G0001AA-M01	Y-DELAY LINE
	17-120003A-K01	INFRARED RECEIVER MODULE HC-370
	19-01001EB-S02	AC LINE CORD L=2
	21-A34102A-T01	COLOUR PICTURE TUBE A34JFQ4OX11(W)
MISCELLANEOUS		
F601	22-200301A-D01	FUSE T2A AC250V
	23-G0002FA-K02	FUSE HOLDER
	23-F0001BA-H01	CRT SOCKET
	26-01001BA-T09	UL PVC TUBE
	26-03002BA-T09	UL PVC TUBE (FOR POWER SWITCH)
	27-02001AA-L02	WIRE TIE
	27-03002AA-L02	COLOR TIE L=60MM
	27-06003AA-L02	Y-FIXER
	27-04004CA-K02	SOLDERING LUG
	27-07007CA-G01	TEST POINT 2.3MM L=15MM
	27-01005AA-L02	CABLE TIE L=4"
	27-01006AA-L02	CABLE TIE L=6"
LD701	16-020001A-T01	LED TLR114A
	14-070001A-M01	TUNER B/G SYSTEM (LVE33-W14)
	12-010002A-N04	SPEAKER 8 OHM 2.5W
	17-080010A-N05	INDOOR ANTENNA MATCHING
	17-100011A-102	TRANSFORMER
	28-010001A-E01	BATTERY 'AAA'

SPECIFICATIONS

Television System	:	B/Gsystem for 625 lines
Colour System	:	PAL
Channel Coverage	:	VHF(L) Channel 2 TO 4 CATV SS1-SS3, S1 VHF(H) Channel 5 TO 12 CATV S2-S20 UHF Channel 21 to 69
Picture Tube size	:	37cm
Aerial	:	75 ohm Unbance (EXT)
Speaker	:	8 Ohm 2.5W
Audio Output	:	(MAX.) 2W
Power Requirements	:	AC220V 50 Hz
Power Consumption r	:	(MAX.) 60W
Dimensions (WxHxD)	:	367mm x 351.5mm x 376.5mm
Weight	:	11Kg

* Design and specifications are subject to change without notice.