



Service Manual

Model 1451 14" (V34cm) Remote Control Colour Television

Model 1451TX 14" (V34cm) Teletext Colour Television

Model 1551 15" (V36cm) FST Remote Control Colour Television

Model 1551TX 15" (V36cm) FST Teletext Colour Television

Model 2031 20" (V48cm) Remote Control Colour Television

Model 2031TX 20" (V48cm) Teletext Colour Television

Model 2131 21" (V51cm) FST Remote Control Colour Television

Model 2131TX 21" (V51cm) FST Teletext Colour Television

Contents

Section	Contents
1	General specifications & notes
2	Safety warning & servicing instructions
3	Main chassis (non teletext) and CRT base PCB
3.1	Circuit diagram.....Insert
3.2	Component location diagram.....Insert
3.3	Block diagram
3.4	Description
3.5	Alignment
3.6	Fault guide
3.7	Parts list
4	Tuning system
4.1	Circuit diagram.....Insert
4.2	Component location diagram.....Insert
4.3	Block diagram
4.4	Circuit description
4.5	Fault guide
4.6	Parts list
5	AV interface
5.1	Circuit diagram
5.2	Component location diagram
5.3	Circuit description
5.4	Alignment
5.5	Parts list
6	SECAM transcoder
6.1	Circuit diagram.....Insert
6.2	Component location diagram.....Insert
6.3	Block diagram
6.4	Circuit description
6.5	Alignment
6.6	Parts list
7	Teletext
7.1	Circuit diagram
7.2	Component location diagram
7.3	Block diagram
7.4	Circuit description
7.5	Alignment
7.6	Fault guide
7.7	Parts list
8	CRT purity and convergence
9	Cabinet & miscellaneous parts list
	Cabinet parts location diagrams

Section 1 - General Specifications & Notes

Colour system	PAL CCIR 625 line SECAM V or H *		
Sound system	FM 5,5MHz (B/G/H) or 6MHz (I)		
Tuning range	VHF Band I	48-106MHz	
		Ch E2-E4	Europe
		Ch A-C	Irish
		Ch S1	Cable
	VHF Band III	115-297MHz	
		Ch E5-E12	Europe
		Ch D-K	Irish
		Ch S3-S20	Cable
	UHF Band	474-858MHz	Channels 21-69 UK
Antenna	75 ohm unbalanced		
Picture tube	PIL 90° pin cushion free		
Power supply	160-264V ~ AC 50Hz		
Audio output	5W RMS @ 10% THD		(8 ohm)
	2W RMS @ 10% THD		(16 ohm)
	Frequency response	25Hz - 12KHz (-3dB)	
AV inputs *	Video 1V peak 75 ohm		
	Audio 250mV 10K ohm		
Teletext *	WST625 (English/German/Swedish)		
* Optional features			

Parts Lists Abbreviations

Resistors	CF	Carbon film
	FR	Fusible
	MO	Metal oxide
	MF	Metal film
	SR	Safety
	WW	Wire wound
	Presets	HRZ
VRT		Vertical mounting
Capacitors		CER
	ELC	Electrolytic
	MKT	Philips 'MKT' type
	MKS	Philips 'MKS' type
	MKT-P	Philips 'MKT-P' type
	FKP1	Wima 'FKP1' type
	FKP2	Wima 'FKP2' type
Tolerances	F	+/- 1%
	G	+/- 2%
	J	+/- 5%
	K	+/- 10%
	M	+/- 20%

Section 2 - Safety and Servicing Precautions

READ THESE SAFETY WARNINGS BEFORE SERVICING THIS CHASSIS.

This television receiver is manufactured to comply with the International Safety Standard IEC65 or its variants (BS415-UK, VDE-GERMANY etc).

WARNING - High voltage. Servicing should only be performed by suitably qualified and experienced personnel.

WARNING - Use an isolation transformer. Although the chassis is isolated from the mains supply, areas of the main PCB are at mains potential. Use a 250-500VA transformer when servicing.

WARNING - Read the following instructions before attempting any repairs or adjustments.

Safety components

Many electrical and mechanical parts in this chassis have special safety-related characteristics which may pass unnoticed by visual inspection. The protection afforded by them cannot necessarily be obtained by using replacement components rated for higher voltage, wattage, etc. The fitting of non-approved components may cause a hazard resulting in electric shock or fire. Replacement parts which have special safety characteristics are identified by the following symbol in this manual and its supplements.



Before replacing any of these components, read the parts list in this manual carefully.

X-ray radiation

This receiver is designed so that X-ray radiation is kept to an absolute minimum. Since certain malfunctions or service-work may generate potentially hazardous radiation with prolonged exposure at close range, the following precautions should be observed.

- ➔ While repairing, ensure that the high voltage does not exceed 26KV (at a beam current of 1 mA).
- ➔ For normal operation, the receiver should require only 24.5KV +/-1.5KV (at a beam current of 1 mA)
- ➔ The only source of X-RAY RADIATION in this TV receiver is the picture tube. For continued X-RAY RADIATION protection, the replacement tube must be of the same type tube as that specified in the parts list.

High voltages

- ➔ Potentials as high as 25,000 volts are present when this receiver is operating. Operation of the receiver outside the cabinet or with the back cover removed presents a shock hazard.
- ➔ Servicing should not be attempted by anyone who is not thoroughly familiar with the precautions necessary when working on high-voltage equipment.

- ➔ Always discharge the picture tube anode to the chassis ground to remove shock hazard before disconnecting the anode cap. Use a lead with a 10K series resistor.
- ➔ Completely discharge the high potential of the picture tube before handling. The picture tube is highly evacuated and if broken, glass fragments will be violently expelled.

Fuses, fusible resistors and power resistors

- ➔ In the event of fuse or fusible resistor replacement they must be replaced with the type specified in the parts list.
- ➔ Power and fusible resistors should be mounted the same distance above the circuit board as the original.

General Servicing Precautions

- ➔ Disconnect the television from the mains supply before discharging the picture tube anode or before removing or refitting any component, circuit board, module or connector.
- ➔ Fitting a wrong part or incorrect polarity of electrolytic capacitors may result in an explosion.
- ➔ Test high voltage only with a high voltage meter or a multi meter equipped with a suitable high voltage probe. Do not test high voltage by "drawing an arc".
- ➔ Do not spray any chemicals on or near this instrument or any of its assemblies.
- ➔ Ensure that all power transistors and integrated circuits have their heatsinks correctly fitted before connecting power. Use heatsink compound where necessary.
- ➔ Electrostatically sensitive (ES) devices. Some integrated circuits in the tuning and teletext circuits can be easily damaged by static electricity. Ensure that no power is applied to the chassis or circuit. Do not remove a replacement ES device from its protective package until you are ready to install it. Do not use freon-propelled chemicals since these can generate electrical charges sufficient to damage ES devices.

Before returning the television to the customer

After servicing is completed, carry out the following safety checks.

- ➔ Inspect lead dress to make certain that leads are not pinched or damaged.
- ➔ Ensure that no loose parts are lodged within the receiver.
- ➔ Inspect and ensure that all protective devices such as non-metallic control knobs, insulators, cabinet backs, adjustment and compartment covers and shields, isolation resistors, capacitor networks, mechanical insulators are refitted correctly.
- ➔ If a mains plug is not fitted, ensure that the mains connection label is fitted.
- ➔ Perform flash, insulation and load tests using a suitable appliance tester.

SECTION 3.3 - MAIN CHASSIS, BLOCK DIAGRAM

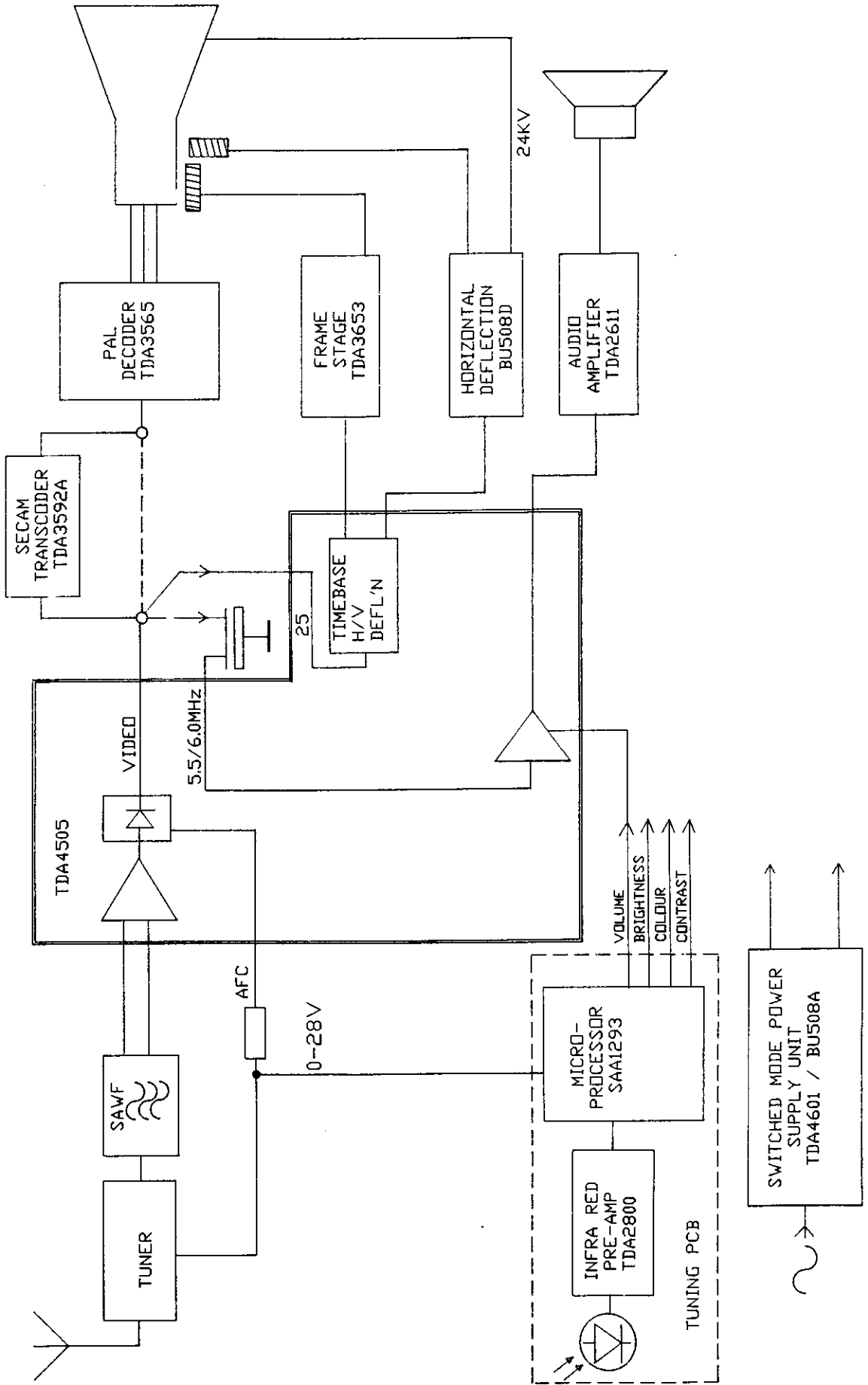

Section 3.4 - Main Chassis, Description

The TDA 4505 combines all the small signal functions (except colour decoder and tuner) necessary for a colour TV receiver. Only output amplifiers for horizontal and vertical deflection and sound are required.

Tuner

Three different tuners may be fitted :-

Type 1604UEC for UHF only

Type 3010UEC for UHF only

Type 1604KKC for VHF/UHF (including cable bands)

The tuners incorporate a preamplifier which is capable of driving the SAW filter directly.

Vision IF and detector

The IF amplifier has a symmetrical input (pins 8,9) and gain controlled stages. Gated AGC is used.

A 90 degree phase shift network is used together with the synchronous video demodulator to provide both AFC and video detection. Only one reference coil (L102) is required.

With very weak input signals the AFC signal can become noisy and errors occur. To prevent this the AFC detector is switched off during no or weak signal conditions.

Sound IF and Audio stages

The composite video output from pin 17 also contains the intercarrier sound signal which passes through the filter Z101 and enters the sound IF stage at pin 15.

The FM signal from the AV board can also be injected here. After FM limiting the signal is demodulated by a quadrature demodulator (L101).

The volume level is controlled by a DC control voltage on pin 11; sound muting also occurs at this stage.

The audio signal from pin 12 is then amplified by a TDA2611A power amplifier.

Horizontal Deflection

The horizontal synchronisation circuit has 2 control loops to enable accurate sand castle timing and to compensate for storage time delays in Q601. Automatic loop time constant switching and sound muting are also included.

Synchronisation pulses are generated by the synch separator (pin 25) which receives video (FBAS) signals from either the video output (pin 17) or external signals via the AV board (K100 pin 5).

In the first control loop the RC oscillator is synchronised with the synchronising pulses from the synch separator.

The phase detector produces an error voltage on pin 24 which controls the frequency of the RC oscillator (pin 23).

The coincidence detector and logic circuits select the correct time constant for weak or strong signals. The circuit also detects signals from a VCR or video disk player and selects the correct time constant.

Picture centring (horizontal shift) is achieved by applying a DC potential from the R116 to the second phase detector circuit (pin 28).

The line (horizontal) output stage Q601, Q600 and T600, T601 are of conventional design.

Pin 27 serves as an input for flyback pulse to synchronise the line (horizontal) oscillator as well as generating a sandcastle pulse for the PAL and SECAM decoders. The flyback pulse from C606 is clamped by diode D604 to produce a 10V square wave. The 4 levels required for the complete sandcastle pulse (frame/vertical blanking, horizontal blanking, colour burst gating and unblanked) are produced by pin 27 clamping the flyback pulse at the required level.

Vertical (frame) deflection.

The vertical deflection circuit consists of a ramp generator, digital divider/counter, controlling logic and an external power amplifier.

No adjustment for vertical frequency is required; 50 or 60Hz signals are selected automatically.

The TDA3565 power amplifier acts as a voltage to current converter amplifying the ramp output from pin 3 of the TDA4505.

The circuit has 2 feedback paths. The voltage across R412 is proportional to the deflection current (and height) and provides AC feedback to pin 4 of the TDA4505. DC feedback is via R407.

AV switching

Transistor Q101 mutes the vision IF and de-activates the AGC and AFC circuits when its base (K001 pin 3) is grounded. The audio mute circuit does not function under this condition.

Standby On/Off

When the standby ON command is received transistor Q809 is turned off allowing the control pin of the regulator IC803 to rise. The regulator turns on providing a 12V supply to the TDA4505 enabling the horizontal oscillator to start. The switch mode power supply operates at all times.

Colour decoder

The PAL decoder integrated circuit (IC500) TDA3565 contains all functions required for identification and demodulation of PAL signals. The RGB output signals from the decoder are fed to the video amplifiers.

SECAM transcoder

The transcoder IC700 converts SECAM signals into PAL which can then be decoded by the PAL decoder TDA3565. For further details see section 6.

Video output amplifiers

These are conventional class A amplifiers.

Switch mode power supply (SMPS)

A free running switch mode power supply ensures good regulation with a wide range of input voltages as well as providing isolation from the mains supply. The control circuit uses a TDA4601D (an improved version of the TDA4600) and incorporates short circuit and overvoltage protection.

A PTC thermistor R802 is used to provide an initial supply to pin 9 of the TDA4601 to allow fast starting.

Section 3.5 - Main Chassis, Adjustments and Alignment.

Equipment required

Digital voltmeter
Oscilloscope
PAL pattern generator

Preparation

Check that all components are fitted and the high voltage leads are connected,
Ensure that the grounding leads between the picture tube ground (aquadag), the CRT base socket and the main chassis are correctly connected.

Set all preset potentiometers in the mid position except R811, which must be set fully anticlockwise.

IMPORTANT. The antenna socket is not isolated from the main chassis. When using test equipment that is grounded a conductive path may exist via the antenna socket.

Power supply (set HT)

Connect a mains supply voltage of 220-240V to the power supply input. Connect DVM between TP13 and chassis ground.

Switch the receiver on and adjust preset potentiometer R811 (HT) for 115V. Turn down brightness so screen is dark then re-check voltage.

Re-adjust R811 if necessary for 115V \pm 0.5V.

Horizontal frequency (Line hold)

Tune to test card or CCIR standard signal.

Connect pin 25 of TDA4505 (IC100) to +11V (TP20).

Adjust the preset potentiometer R126 (H-F) for minimum rolling of the picture.

Horizontal shift

Centre picture with preset R116 (H-SH) control.

Horizontal width and linearity

Not adjustable.

Tuner AGC take over point

Method 1.

Tune to a CCIR standard signal with a level of between 5 and 20mV.

Connect an oscilloscope that has a frequency response of at least 60MHz to the input of the SAW filter Z100 (pin 1). Use a low capacitance probe (2pf, X10).

Adjust preset potentiometer R102 (AGC) for a voltage of 1V p-p.

Method 2.

Tune to a CCIR signal with a level of 1.5mV.

Turn R102 anticlockwise until snow appears or contrast reduces slightly. Rotate R102 clockwise until the snow just disappears.

Increase signal level to 30mV and check that overloading or sound buzz does not occur.

Vertical (frame) height and linearity

Adjust pre-set potentiometer R410 (V-A) for 6% over scan.

Adjust pre-set potentiometer R409 (V-Lin) for best linearity.

Adjust pre-set potentiometer R505 (V-shift) for correct vertical position.

Colour reference oscillator

Tune to a PAL colour bar pattern.

To override the colour killer, connect pin 11 of IC500 (TP29) to +11V (TP25).

Connect TP32 and TP33 together.

Adjust potentiometer R527 (FREQ) for minimum rolling of colour bars.

PAL matrix adjustment

Tune to a TV PAL signal that has anti PAL (colourless) areas.

Method 1

Connect an oscilloscope to the BLUE output (K501 pin 3).

Adjust delay line amplitude (DL-AMP) preset R502 and delay line phase (DL-P) coil L503 to minimise the alternating (double image) waveforms. See Figs 1 and 2)

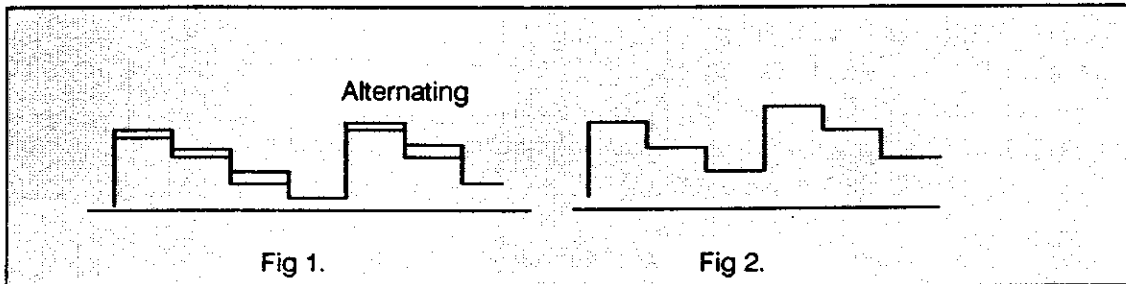

Method 2

Connect an oscilloscope that has X and Y inputs to the RED and BLUE outputs.

(X to K501 pin 4 RED) (Y to K501 pin 2 BLUE).

Adjust the colour, brightness and contrast controls to produce a vector display on the oscilloscope.

Adjust the delay line amplitude (DL-AMP) preset R520 to reduce the amplitude of the small vectors (Hannover blind errors) (see Fig 3), and the delay line phase (DL-P) coil L503 to superimpose the outer vectors (see Fig 4).

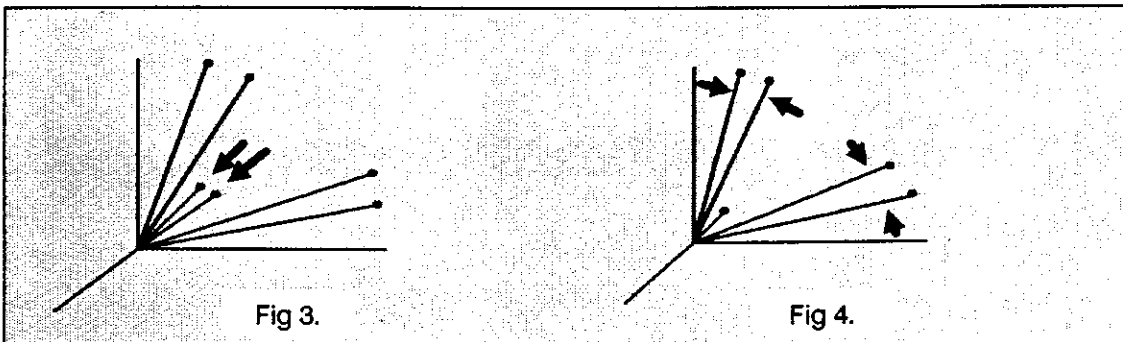

Note: some of the test patterns may not produce clearly defined vectors. In such cases method 1 should be used.

Picture tube greyscale

Tune to an unmodulated test pattern (blank or white raster).

Turn brightness, colour and contrast to minimum.

Set the drive presets R703 (G-DR) and R705 (B-DR) to mid position.

Set the background (cut-off) presets R713, R725, R727 and the A1 (screen) control to minimum.

Method 1

Open jumper J403 to cut supply of vertical output stage.

Connect TP34 (sandcastle) to TP21 (+12V).

Connect oscilloscope to the RED cathode pin 8 on CRT.

Adjust pre-set potentiometer R713 for required cut-off voltage on pin 8 of CRT. Adjust screen grid control for minimum light and re-adjust with R713 for correct cut-off voltage.

Afterwards do not change R713.

Adjust pre-set potentiometer R725 and R727 to obtain a just visible white line.

Remove interconnection TP34 and TP21 and close jumper J403.

Check CRT data for cut-off voltage recommended for optimal performance of CRT.

Tune to greyscale (staircase) pattern.

Set contrast control to maximum.

Adjust pre-set potentiometers R703 and R705 until best white balance is obtained.

Method 2

Disconnect plug K400 (vertical).

Turn the A1 (screen) control until a coloured line appears. Note colour.

Turn the A1 control down until the line is extinguished.

Adjust the background presets for the remaining two colours to produce a coloured line before turning each preset anticlockwise to extinguish the line.

Reconnect plug .K400 and tune to a grey scale (staircase test pattern).

Set contrast to a high level.

Adjust the DRIVE presets R703 and R705 for correct white balance on the highlights.

ALIGNMENT

Alignment frequencies

<u>SYSTEM</u>	<u>VISION IF</u>	<u>SAW FILTER</u>	<u>SOUND IF</u>	
B/G	38.9MHz	SY177	5.5MHz	PAL/SECAM-V
H	38.9MHz	SY177/SY178	5.5MHz	PAL/SECAM-H
I (UK)	39.5MHz	SY153A	6.0MHz	PAL
I (IRELAND)	38.9MHz	SY453A	6.0MHz	PAL

Video detector

Inject IF signal (38.9 or 39.5MHz) modulated with staircase (greyscale) waveform into tuner IF injection point.

The television should be switched to UHF band if a VHF/UHF model.

Connect voltmeter to TP4 (AFC) and an oscilloscope to the video output K100 pin 1.

The AFC voltage will change from 0 to 12V as the AFC tuning point is passed.

Adjust L102 for approximately 6V.

Note: Several false tuning points may be obtained; only the correct point will produce a linear staircase (step) video waveform.

Sound detector

Tune to a signal with a test tone.

Connect an oscilloscope to pin 12 of IC100 or across the loud speaker (see note on ground path).

Set volume control in mid position.

Adjust the detector coil L101 for good symmetrical sine wave.

A FM signal generator connected via a 1nF capacitor to the junction of L103 and R143 may be used if a CCIR signal is not available.

Set the generator to the correct frequency (5.5 or 6.0MHz), 50KHz deviation, 10mV amplitude and 1KHz modulation.

Sound trap

As the AFC cannot be defeated, the conventional method of tuning the television off frequency slightly to produce an increased sound carrier cannot be used.

Method 1

Inject a monochrome signal with FM sound into the IF injection point.

The video carrier frequency should be 200-300kHz higher than the standard IF frequency e.g. 39.2MHz for B/G (38.9MHz), 39.8MHz for I (39.5MHz).

Connect an oscilloscope to video output on K100 pin 1.

Adjust L104 for minimum sound carrier on the video signal.

Method 2

Tune to an unmodulated signal (blank raster) with no sound carrier.

Connect a signal generator 5.5MHz (or 6MHz) CW to pin 17 of the TDA4505.

Connect an oscilloscope to the video output on K100 pin 1.

Adjust L104 for minimum sound carrier on the video waveform.

Chroma trap

Method 1.

Tune to a TV PAL signal.

Connect oscilloscope to R to B or G signal connector K501 pins 2, 3 or 4.

Adjust L501 for minimum colour sub-carrier on the R, G or B signals.

Method 2.

Inject a 4,433MHz signal into pin 7 of the SECAM socket.

Adjust L501 as in method 1.

Chroma band-pass

Method 1.

Tune to a PAL colourbar test pattern.

Connect oscilloscope via a probe (smaller than 2pF loading) to pin 3 of IC500.

Adjust with L500 for maximum amplitude of the chromanence waveform and optimum square wave signals at the output on K501.

Method 2.

Connect a sweep generator (wobbulator) to pin 8 of the SECAM socket.

Connect the detector via a high impedance oscilloscope probe to pin 3 of IC500.

System B/G

Set the generator to 4,43MHz centre frequency and 50mV amplitude.

Adjust coil L500 for maximum amplitude at 4,43MHz.

System I

Set centre frequency to 5MHz. Adjust coil L500 so that the 4,43MHz marker is 2dB from top.

Section 3.6 - Main Chassis, Fault Guide

Dead. (No sound, raster or programme indicator.)	Noise (squeal) from power supply.	Check D804, D808, Q600, C813, C601, C602, C600, C604.
	No output from power supply. (115V, 25V, 17V)	Check F800, IC800, R802, R805, R808.
	115V o.k.	Check IC300, IC302. (Remote control PCB)
No sound or raster (horizontal stage not working). Standby indicator lit.	Programme numbers and tuning functions not working.	See fault guide in section 4.5
	No 12V on TP21.	Check IC803, Q809, R844, K804 pin 2 low (0V).
	TP21 (12V) o.k.	Check 12V on IC100 pin 7, IC100, Q601, R600, R605.
No raster. Horizontal stage OK. (Note: sound will be muted if set not tuned to signal.)	Turn A1 (screen) control up.	
	Horizontal line visible	Check IC400, IC100 and periferal components.
	Raster visible.	Check Q702, IC500 pin 1 (12V) pin 9/TP28 (2-4V).
No picture. (Sound may be muted.)	Sound not muted even if tuned off station.	Check Q101, C120, AV PCB.
	Sound appears when tuned to station.	Check AV and SECAM modules Q103, IC500.
No sound	Picture synchronised.	Check IC200, IC100 pin 12 (AF) pin 11 (0-6V), Alignment of L102.
	Picture not synchronised.	Check IC100 pin 25 (FBAS), AV module.
No colour. (PAL decoder only.)	Override colour killer. (TP26 to +12V)	
	No colour.	Check IC500 pin 3 (chroma), pin 16 (8.86MHz), Pin 7 (Sandcastle).
	Coloured bands	Check alignment of R527 (freq).
No colour. (PAL/SECAM.)	No SECAM, PAL ok.	Check alignment/components in SECAM module.
	No SECAM or PAL colour.	Check PAL decoder, SECAM module.

IMPORTANT Discharge C809 before replacing IC800.

Section 3.7 - Main Chassis, Parts List

Circuit Ref	Description	Part Number	Comment
R001	RESISTOR MO	15K 2W J	112188
R002	RESISTOR CF	150K 0.25W J	104151
R010	RESISTOR CF	2M2 0.25W J	105221
R011	RESISTOR CF	47K 0.25W J	103475
R012	RESISTOR CF	100K 0.25W J	104110
R013	RESISTOR CF	100K 0.25W J	104110
R014	RESISTOR CF	10R 0.25W J	100107
R015	RESISTOR CF	68K 0.25W J	103686
R016	RESISTOR CF	1K2 0.25W J	102126
R017	RESISTOR CF	68K 0.25W J	103686
R018	RESISTOR CF	12K 0.25W J	103122
R019	RESISTOR CF	470K 0.25W J	104470
R100	RESISTOR CF	2M2 0.25W J	105221
R101	RESISTOR CF	15K 0.25W J	103155
R102	PRESET HRZ	47K 5x10mm	133470
R103	RESISTOR CF	6K8 0.25W J	102685
R104	RESISTOR CF	2M7 0.25W J	105272
R105	RESISTOR CF	33K 0.25W J	103336
R107	RESISTOR CF	12K 0.25W J	103122
R108	RESISTOR CF	10R 0.25W J	100107
R109	RESISTOR CF	4K7 0.25W J	102479
R110	RESISTOR CF	10K 0.25W J	103116
R111	RESISTOR CF	3K3 0.25W J	102338
R114	RESISTOR CF	47K 0.25W J	103475
R115	RESISTOR CF	82K 0.25W J	103825
R116	PRESET HRZ	47K 5x10mm	133470
R117	RESISTOR CF	2M7 0.25W J	105272
R119	RESISTOR CF	1K5 0.25W J	112156
R120	RESISTOR CF	10K 0.25W J	103116
R125	RESISTOR CF	30K 0.25W J	103305
R126	PRESET HRZ	10K 5x10mm	133141
R129	RESISTOR CF	1K8 0.25W J	102189
R131	RESISTOR CF	4K7 0.25W J	102479
R132	RESISTOR CF	3K3 0.25W J	102338
R133	RESISTOR CF	22K 0.25W J	103224
R134	RESISTOR CF	680K 0.25W J	104681
R135	RESISTOR CF	22K 0.25W J	103224
R136	RESISTOR CF	100K 0.25W J	104110
R140	RESISTOR CF	2K2 0.25W J	102227
R141	RESISTOR CF	330R 0.25W J	101331
R142	RESISTOR CF	680R 0.25W J	101683
R144	RESISTOR CF	4K7 0.25W J	102479
R145	RESISTOR CF	100R 0.25W J	101106
R200	RESISTOR FR	4R7 1W J	129470
R202	RESISTOR CF	6R8 0.25W J	109680
R400	RESISTOR CF	1K 0 0.25W J	102101
R401	RESISTOR FR	4R7 1W J	129470
R402	RESISTOR CF	3K9 0.25W J	102397
R403	RESISTOR CF	10K 0.25W J	103116
R404	RESISTOR CF	470R 0.25W J	104470
R405	PRESET HRZ	10K 5x10mm	133141
R406	RESISTOR CF	270R 0.25W J	101274
R007	RESISTOR CF	56K 0.25W J	103561
R408	RESISTOR CF	10K 0.25W J	103116
R409	PRESET HRZ	4K7 5x10mm	132474
R410	PRESET HRZ	100R 5x10mm	131102
R411	RESISTOR CF	22K 0.25W J	103224
R412	RESISTOR CF	1R8 0.25W J	109180
R413	RESISTOR CF	1K 0 0.25W J	102101

20" & 21" MODELS ONLY

PAL B/G AND SECAM MODELS ONLY

For Service Manuals
MAURITRON SERVICES
 8 Cherry Tree Road, Chinnor
 Oxfordshire, OX9 4QY.
 Tel (01844) 351694
 Fax (01844) 352554
 email:- sales@mauritron.co.uk

Circuit Ref	Description	Part Number	Comment	
R500	RESISTOR	FR 4R7 0.25W	J 129480	
R502	RESISTOR	CF 100R 0.25W	J 104110	
R503	RESISTOR	CF 2K2 0.25W	J 102227	
R504	RESISTOR	CF 1K0 0.25W	J 102101	
R505	RESISTOR	CF 560R 0.25W	J 101562	
R507	RESISTOR	CF 1K0 0.25W	J 102101	
R508	RESISTOR	CF 1K2 0.25W	J 102126	
R510	RESISTOR	CF 6K8 0.25W	J 102685	NON-TELETEXT MODELS ONLY
R511	RESISTOR	CF 75K 0.25W	J 103752	NON-TELETEXT MODELS ONLY
R512	RESISTOR	CF 15K 0.25W	J 103155	NON-TELETEXT MODELS ONLY
R513	RESISTOR	CF 120K 0.25W	J 104123	NON-TELETEXT MODELS ONLY
R514	RESISTOR	CF 330K 0.25W	J 104332	NON-TELETEXT MODELS ONLY
R515	RESISTOR	CF 68K 0.25W	J 103686	NON-TELETEXT MODELS ONLY
R519	RESISTOR	CF 1K2 0.25W	J 102126	NON-TELETEXT MODELS ONLY
R520	PRESET	HRZ 1K0 5x10mm	132100	NON-TELETEXT MODELS
R521	RESISTOR	CF 390R 0.25W	J 101395	NON-TELETEXT MODELS ONLY
R522	RESISTOR	CF 1K 0.25W	J 102101	NON-TELETEXT MODELS ONLY
R523	RESISTOR	CF 470K 0.25W	J 101470	NON-TELETEXT MODELS ONLY
R527	PRESET	HRZ 1K0 5x10mm	113141	NON-TELETEXT MODELS ONLY
R528	RESISTOR	CF 1M0 0.25W	J 105106	NON-TELETEXT MODELS ONLY
R529	RESISTOR	CF 2K7 0.25W	J 102273	
R600	RESISTOR	WW 2R7 4W	K 129227	
R601	RESISTOR	MO 10K 2W	K 113102	
R603	RESISTOR	SR 220K 0.25W	K 104222	
R604	RESISTOR	CF 47K 0.25W	J 102479	
R605	RESISTOR	MO 5K6 2W	J 112564	
R606	RESISTOR	CF 1K8 0.25W	J 102189	
R607	RESISTOR	CF 4K7 0.25W	J 102479	
R608	RESISTOR	CF 330K 0.25W	J 101331	
R609	RESISTOR	CF 10K 0.25W	J 103116	
R610	RESISTOR	MF 1K0 1W	J 112108	
R611	RESISTOR	CF 8K2 0.25W	J 102825	
R612	RESISTOR	MO 3M3 1W	K 115330	21" VIDEOCOLOR A5IEBV CRT ONLY ALL OTHER MODELS
	OR LINK			
R800	RESISTOR	CF 220K 0.25W	J 104222	
R801	RESISTOR	WW 2R7 4W	K 129227	
R802	THERMISTOR	2322 672 96009	154214	PTC
R803	RESISTOR	MF 2K7 1W	J 112270	
R804	THERMISTOR	2322 662 98009	154213	DEGAUSS
R805	RESISTOR	MF 0R82 0.25W	J 119824	
R806	RESISTOR	CF 27R 0.25W	J 100271	
R808	RESISTOR	CF 100K 0.25W	J 104110	
R809	RESISTOR	CF 270K 0.25W	J 104273	
R810	RESISTOR	CF 15K 0.25W	J 103155	
R811	PRESET	HRZ 4K7 5x10mm	132474	
R812	RESISTOR	MO 47R 1W	K 110470	
R813	RESISTOR	FR 0R22 1W	J 129228	
R814	RESISTOR	CF 10K 0.25W	J 103116	
R815	RESISTOR	CF 1K2 0.25W	J 102126	
R816	RESISTOR	CF 220R 0.25W	J 101223	
R817	RESISTOR	SR 4M7 0.5W	K 125470	
R844	RESISTOR	FR 4R7 1W	J 129470	
R845	RESISTOR	CF 390R 0.25W	J 101395	
R846	RESISTOR	CF 3K3 0.25W	J 102338	
R847	RESISTOR	CF 10K 0.25W	J 103116	
C001	CAPACITOR	CER 1n0 50V	K 224108	
C007	CAPACITOR	MKT 100n 100V	M 214137	
C008	CAPACITOR	CER 10n 50V	K 223135	
C009	CAPACITOR	ELC 1u0 16V	233131	
C010	CAPACITOR	ELC 4u7 50V	239488	
D100	DIODE	BAW62	302964	PAL BG & SECAM MODELS ONLY
D101	DIODE	BAW62	302964	PAL BG & SECAM MODELS ONLY
D011	CAPACITOR	CER 10n 50V	K 224108	

Circuit Ref	Description	Part Number	Comment
C012	CAPACITOR ELC 1u0 16V	233131	
C013	CAPACITOR CER 10n 50V	K 224108	
C014	CAPACITOR ELC 1u0 16V	233131	
C015	CAPACITOR ELC 68u 16V	230681	
C016	CAPACITOR CER 10n 50V	K 224108	
C017	CAPACITOR CER 10n 50V	K 224108	
C019	CAPACITOR ELC 1u0 63V	239119	
C100	CAPACITOR MKT 220n 63V	K 214226	
C101	CAPACITOR ELC 22u 16V	231258	
C102	CAPACITOR CER 1n0 50V	K 224108	
C103	CAPACITOR ELC 330u 16V	232331	
C104	CAPACITOR CER 2n2 50V	K 222238	
C105	CAPACITOR CER 1n2 50V	K 222151	
C106	CAPACITOR CER 1n0 50V	K 224108	
C107	CAPACITOR ELC 1u0 35V	233132	
C108	CAPACITOR ELC 22u 16V	231258	
C109	CAPACITOR CER 22n 50V	M 223247	
C110	CAPACITOR CER 68p 50V	M 220701	PAL BG & SECAM MODELS
	CAPACITOR CER 39p 50V	M 220399	PAL I MODELS
C111	CAPACITOR CER 22n 50V	M 223247	
C112	CAPACITOR MKT 100n 100V	M 214137	
C113	CAPACITOR CER 150p 50V	J 221172	
C114	CAPACITOR MKT 22n 63V	K 214226	
C115	CAPACITOR ELC 10u 16V	230143	
C116	CAPACITOR PYF 2n7 160V	G 212274	
C117	CAPACITOR ELC 1u0 50V	239128	
C118	CAPACITOR MKT 470n 63V	M 214485	
C119	CAPACITOR MKT 220n 63V	J 214226	
C120	CAPACITOR ELC 1u0 35V	239128	
C121	CAPACITOR MKT 100n 100V	M 214137	
C122	CAPACITOR ELC 100u 16V	232161	
C123	CAPACITOR CER 150p 50V	J 221172	
C125	CAPACITOR CER 150p 50V	J 221173	PAL BG & SECAM MODELS
	CAPACITOR CER 120p 50V	J 221174	PAL I MODELS
C126	CAPACITOR CER 560p 50V	K 221560	
C127	CAPACITOR CER 68p 50V	J 220702	
C128	CAPACITOR CER 15p 50V	J 220170	
C200	CAPACITOR CER 22n 50V	M 223247	
C201	CAPACITOR ELC 1000u 35V	233132	
C202	CAPACITOR MKT 100n 100V	M 214137	
C203	CAPACITOR CER 10n 50V	K 223135	
C204	CAPACITOR CER 22n 50V	M 223247	
C205	CAPACITOR MKT 100n 100V	M 214137	
C206	CAPACITOR MKT 100n 100V	M 214137	
C207	CAPACITOR ELC 330u 25V	232333	
C400	CAPACITOR CER 4n7 50V	K 222480	
C401	CAPACITOR CER 4n7 50V	K 222480	
C402	CAPACITOR CER 470p 50V	K 221501	
C403	CAPACITOR ELC 100u 50V	232164	
C404	CAPACITOR ELC 220u 35V	232254	
C405	CAPACITOR MKT 100n 100V	M 214137	
C406	CAPACITOR MKT 100n 100V	M 214137	
C407	CAPACITOR ELC 1500u 35V	233155	
C408	CAPACITOR ELC 2u2 50V	239235	
C500	CAPACITOR ELC 100u 25V	232163	
C501	CAPACITOR CER 22n 50V	M 223247	NON-TELETEXT MODELS ONLY
C502	CAPACITOR CER 82p 50V	M 220833	
C503	CAPACITOR ELC 4u7 25V	239488	NON-TELETEXT MODELS ONLY
C504	CAPACITOR CER 270p 50V	K 221280	
C505	CAPACITOR CER 10n 50V	K 223135	NON-TELETEXT MODELS ONLY
C506	CAPACITOR CER 68p 50V	J 220702	
C507	CAPACITOR MKT 330n 63V	K 214336	NON-TELETEXT MODELS ONLY
C509	CAPACITOR CER 150p 50V	J 221172	

Circuit Ref	Description	Part Number	Comment
C511	CAPACITOR MKT 220n 63V	K 214226	
C512	CAPACITOR ELC 1u0 50V	239128	NON-TELETEXT MODELS ONLY
C513	CAPACITOR ELC 10u 16V	230143	NON-TELETEXT MODELS ONLY
C514	CAPACITOR ELC 1u0 50V	239128	NON-TELETEXT MODELS ONLY
C517	CAPACITOR MKT 100n 100V	M 214137	NON-TELETEXT MODELS ONLY
C519	CAPACITOR CER 10n 50V	K 223135	NON-TELETEXT MODELS ONLY
C527	CAPACITOR CER 10p 50V	J 220112	NON-TELETEXT MODELS ONLY
C528	CAPACITOR ELC 1u0 50V	239128	NON-TELETEXT MODELS ONLY
C529	CAPACITOR CER 270p 50V	K 221280	NON-TELETEXT MODELS ONLY
C530	CAPACITOR CER 270p 50V	K 221280	NON-TELETEXT MODELS ONLY
C600	CAPACITOR ELC 10u 250V	231161	
C601	CAPACITOR ELC 1u0 250V	215106	
C602	CAPACITOR ELC 22u 160V	231259	
C603	CAPACITOR MKT 47n 100V	K 231487	
C604	△ CAPACITOR MKP10 470n 250V	M 214486	14" & 20" MODELS
	△ CAPACITOR MKP10 330n 250V	M 214342	15" & 21" MODELS
C605	△ CAPACITOR FKP1 7n5 1.5kV	J 213750	14" & 20" MODELS
	△ CAPACITOR FKP1 6n8 1.5kV	J 212689	21" MODELS ONLY
	△ CAPACITOR FKP1 5n6 1.5kV	J 212566	15" MODELS ONLY
C606	CAPACITOR MKT 100n 100V	M 214137	
C607	CAPACITOR MKT 220n 100V	K 214227	
C608	CAPACITOR CER 1n0 50V	K 224108	
C609	△ CAPACITOR ELC 1u0 160V	239129	
C800	CAPACITOR CER 1n0 1KV	K 222169	
C801	CAPACITOR CER 1n0 1KV	K 222169	
C802	CAPACITOR CER 1n0 1KV	K 222169	
C803	CAPACITOR CER 1n0 1KV	K 222169	
C804	△ CAPACITOR ELC 150u 385V	232160	
C805	△ CAPACITOR MKT-P 470n 250V	M 214487	
C806	△ CAPACITOR MKT-P 150n 250V	M 214161	
C807	△ CAPACITOR MKT-P 100n 250V	M 214139	
C808	CAPACITOR CER 330p 1KV	K 221351	
C809	CAPACITOR ELC 100u 25V	232163	
C810	CAPACITOR ELC 100u 16V	232161	
C811	CAPACITOR FKP1 5n6 1KV	J 232565	
C812	CAPACITOR CER 330p 1KV	J 221351	
C813	△ CAPACITOR ELC 100u 160V	232165	
C814	CAPACITOR FKP2 6n8 100V	K 212688	
C815	CAPACITOR ELC 1000u 35V	233132	
C816	CAPACITOR CER 100p 50V	J 221174	
C817	CAPACITOR CER 330p 1KV	J 221351	
C818	CAPACITOR ELC 2200u 25V	233241	
C819	CAPACITOR ELC 100u 10V	232164	
C820	CAPACITOR ELC 1u0 100V	239125	
C821	CAPACITOR FKP2 4n7 100V	K 212487	
C822	△ CAPACITOR CER 4n7 4KV	222480	CSF VDE / BS415
C834	CAPACITOR MKT 330n 63V	K 214336	
C835	CAPACITOR MKT 330n 63V	K 214336	
C836	CAPACITOR ELC 1000u 16V	233131	
C837	CAPACITOR MKT 330n 63V	K 214336	
C838	CAPACITOR ELC 100u 16V	232161	
L100	COIL CHOKE 0u68	052690	
L101	COIL SOUND DET 421	052691	
L102	COIL VIDEO REF 185	052692	
L103	COIL CHOKE 6u8	052733	
L104	COIL SOUND TRAP 191	052693	
L500	COIL CHROMA PASS 384	052694	
L501	COIL CHROMA TRAP 412	052695	
L503	COIL PAL DELAY PHASE 412	052695	NON-TELETEXT MODELS ONLY
L504	COIL CHOKE 12u	053321	NON-TELETEXT MODELS ONLY
L601	△ COIL LINEARITY AT4042/90	052697	14" & 20" MODELS
	△ COIL LINEARITY AT4042/91	052728	15" MODELS
	△ COIL LINEARITY AT4042/34	052725	21" MODELS

Circuit Ref	Description	Part Number	Comment
L800 !	COIL MAINS FILTER 27mH	052698	
L801	COIL CHOKER 4u7	052699	
L802	CORE FERRITE 47u	055137	
L803	COIL CHOKER 150u	052700	
L808	CORE FERRITE	055553	
L809	CORE FERRITE	055552	
L810	COIL CHOKER 4u7	052699	
L811	CORE FERRITE	055552	
T600	TRANSFORMER DRIVER AT4043/01	051550	
T601	TRANSFORMER FBT AT2079/10	051551	
T801	TRANSFORMER SMPS AT3010/110C1	051552	
D001	DIODE ZTK33	302950	
D002	DIODE 1N4148	302289	
D400	DIODE 1N4004	302947	
D600	DIODE BA157	300305	
D602	DIODE 1N4148	302289	
D603	DIODE BA157	300305	
D604	DIODE ZPD 10V	302951	
D800	DIODE 1N4007	302948	
D801	DIODE 1N4007	302948	
D802	DIODE 1N4007	302948	
D803	DIODE 1N4007	302948	
D804	DIODE BY398	302949	
D805	DIODE 1N4007	302948	
D806	DIODE BY298	302295	
D807	DIODE BA157	300305	
D808	DIODE BY298	302295	
D809	DIODE BA157	300305	
Q001	TRANSISTOR JC501	400921	
Q101	TRANSISTOR JC501	400921	
Q102	TRANSISTOR JA101	400920	
Q103	TRANSISTOR JC501	400921	
Q600	TRANSISTOR BU508DR	400922	
Q601	TRANSISTOR BC639	400337	
Q800	TRANSISTOR BU508A	400923	
Q809	TRANSISTOR JC501	400921	
IC100	I.C. TDA4505-N4	451340	
IC200	I.C. TDA2611A/N4	451341	
IC400	I.C. TDA3653	451342	
IC500	I.C. TDA3565	451343	NON-TELETEXT MODELS ONLY
C800	I.C. TDA4601B	451344	
IC803	I.C. LM317T	451345	
F800	FUSE T1.6A/250V	054205	
	FUSE HOLDER	030306	
ET1	TUNER 1604UEC OR 3010UEC	597136	PAL I MODELS
	TUNER 1600KKC	599136	PAL BG & SECAM MODELS
Z100	SAW FILTER SY153	056733	PAL I MODELS
	SAW FILTER SY177	056727	PAL BG & SECAM MODELS
Z101	CERAMIC FILTER 6.0MB	056734	PAL I MODELS
	CERAMIC FILTER 5.5MB	056728	PAL BG & SECAM MODELS
Z500	DELAY LINE DL701	052701	NON-TELETEXT MODELS ONLY
Z501	DELAY LINE DL470	052702	
X500	CRYSTAL 8.867 MHz	056729	NON-TELETEXT MODELS ONLY
	PCB, COMPLETE	{	14" PAL I
	PCB, COMPLETE	{	14" PAL BG
	PCB, COMPLETE	{ QUOTE	15" PAL I
	PCB, COMPLETE	{	15" PAL BG
	PCB, COMPLETE	{ MODEL	20" PAL I
	PCB, COMPLETE	{	20" PAL BG
	PCB, COMPLETE	{	21" PAL I
	PCB, COMPLETE	{	21" PAL BG

CRT Base PCB

Circuit Ref	Description	Part Number	Comment	
R700	RESISTOR	CF 470R 0.25W J	104470	
R701	RESISTOR	CF 3K3 0.25W J	102338	
R702	RESISTOR	CF 1K2 0.25W J	102126	
R703	PRESET	HRZ 2K2 5x10mm	132226	
R704	RESISTOR	CF 3K3 0.25W J	102338	
R705	PRESET	HRZ 2K2 5x10mm	132226	
R706	△ RESISTOR	CF 220R 0.25W J	104222	
R707	RESISTOR	CF 3K3 0.25W J	102338	
R708	RESISTOR	CF 4K7 0.25W J	129480	
R709	RESISTOR	CF 4K7 0.25W J	129480	
R710	RESISTOR	CF 1K2 0.25W J	102126	
R712	RESISTOR	CF 820R 0.25W J	101820	
R713	RESISTOR	CF 2K2 5x10mm	132226	
R714	△ RESISTOR	MF 10K 1W G	113103	
R715	△ RESISTOR	SR 220K 0.5W J	124220	
R716	△ RESISTOR	CF 470R 0.25W J	101470	
R717	△ RESISTOR	MF 1R0 1W G	119105	14" MODELS
	△ RESISTOR	MF 2R2 1W G	118225	15" MODELS
	△ RESISTOR	MF 1R0 1W G	119105	20" MODELS
	△ RESISTOR	MF 1R0 1W G	119105	21" VIDEOCOLOR A51EBV CRT
	△ RESISTOR	MF 2R2 1W G	118225	21" PHILIPS A51EAL CRT
R718	RESISTOR	MO 1K5 0.5W K	112156	
R719	RESISTOR	MO 1K5 0.5 W K	112156	
R720	RESISTOR	MO 1K5 0.5W K	112156	
R721	RESISTOR	CF 820R 0.25W J	101820	
R722	△ RESISTOR	MF 10K 1W G	113103	
R724	RESISTOR	CF 470R 0.25W J	101470	
R725	PRESET	HRZ 2K2 5x10mm	132226	
R726	RESISTOR	CF 820R 0.25W J	101820	
R727	PRESET	HRZ 2K2 5x10mm	132226	
R728	△ RESISTOR	MF 10K 1W G	113103	
R730	RESISTOR	CF 470R 0.25W J	101470	
R731	△ RESISTOR	FR 100R 0.25W J	101106	
C701	CAPACITOR	CER 220p 50V K	221245	
C702	△ CAPACITOR	CER 10n 1KV K	223134	
C703	CAPACITOR	ELC 150u 16V	232166	
C705	CAPACITOR	CER 220p 50V K	221245	
C706	CAPACITOR	MKT 47n 100V K	213487	
C708	CAPACITOR	CER 220p 50V K	221245	
C709	CAPACITOR	ELC 10u 250V	231161	
D700	DIODE	1N4148	302289	
D701	DIODE	1N4148	302289	
D702	DIODE	1N4148	302289	
T700	TRANSISTOR	BF869	400924	
T701	TRANSISTOR	BF869	400924	
T702	TRANSISTOR	JA101	400920	
T703	TRANSISTOR	BF869	400924	
	△ SOCKET	CRT	031763	14", 20" & 21" MODELS
	△ SOCKET	CRT	031779	15" MODELS
	PCB, COMPLETE		577165	14" MODELS
	PCB, COMPLETE		569165	15" MODELS
	PCB, COMPLETE		597165	20" & 21" MODELS

SECTION 4.3 - TUNING SYSTEM, BLOCK DIAGRAM

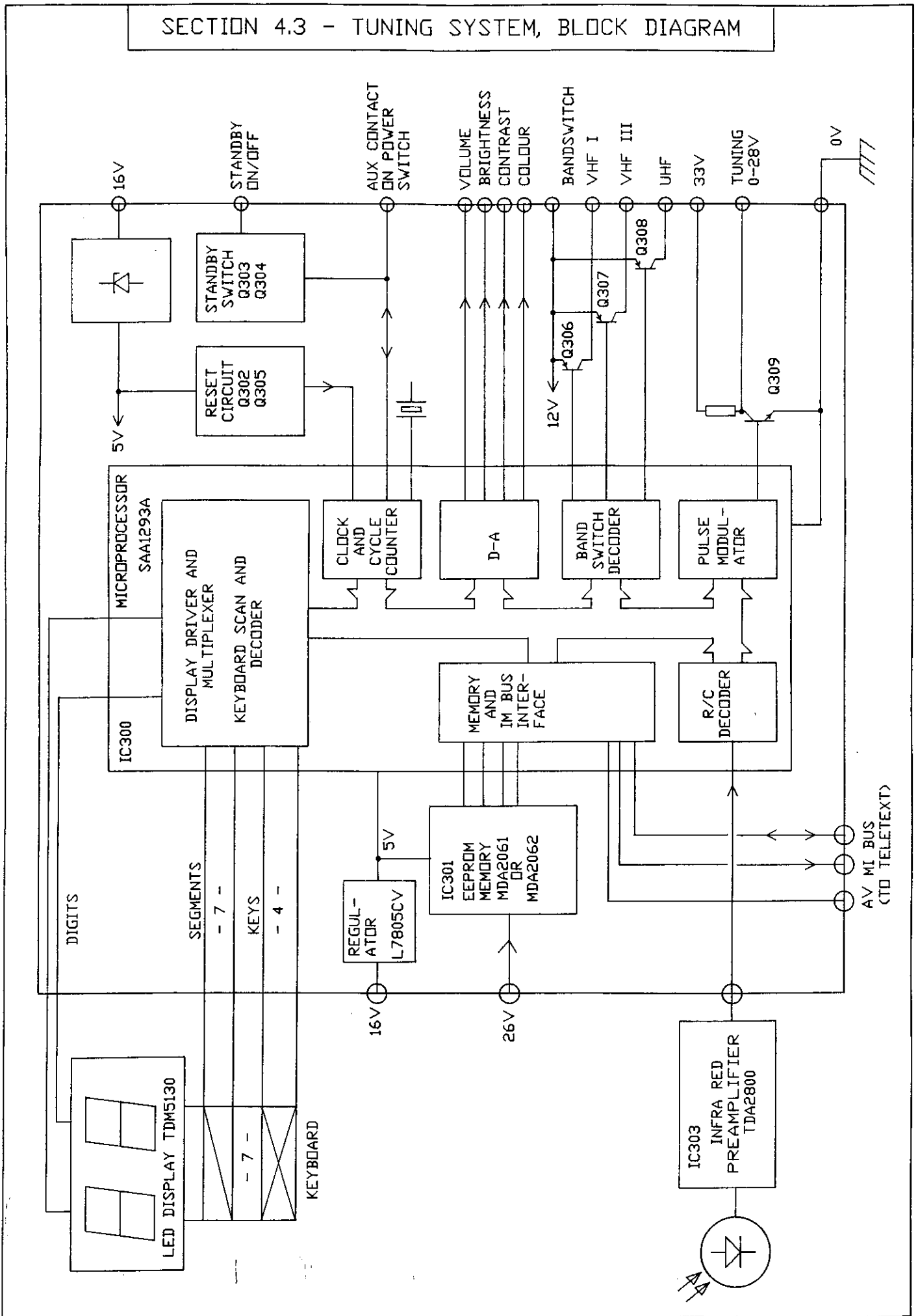

Section 4.4 - Tuning System, Description

Central Processor SAA 1293A

The SAA 1293A is a single chip microcomputer in n-channel MOS technology and together with an EEPROM can perform all the operating and tuning functions of a TV receiver.

Most important features of the SAA 1293 are :

- voltage synthesized tuning system
- storage of up to 55 stations
- four analog outputs for volume, brightness etc
- last used analogue levels memorised
- normalised (ideal) analogue levels can be preset
- 2 digit display indicates station (programme) number, tuning scale, band switch etc
- direct interfacing with teletext system
- programmable tuning options (not accessible to customer)

Power on reset.

The circuit D301, Q302, Q305 etc forces the reset line (pin 4) high once the 5 and 12V supplies are above a certain level.

Standby on/off.

Pin 5 is a bidirectional input/output port. In standby mode the output is high turning Q303 off. If the mains switch is operated, the auxillary (wiping) contact shorts pin 5 to ground, this input is read by the microcomputer which then holds pin 5 low.

Standby and ON commands from the remote control also control pin 5.

Tuning voltage.

Pulses of variable width from pin 13 drive the switching transistor Q309. The waveform at the collector (33V peak square wave) is averaged and filtered by a RC Network to produce a DC tuning voltage.

This voltage (0-28V) is proportional to pulse width and pulse shape.

Analog outputs

Pins 10, 11, 33 and 34 produce variable width pulses of 12V amplitude; filtering by the RC networks R319/C304 etc produces a DC control voltage.

Pin 34 is intended for volume control and is clamped by D310 to prevent the control voltage rising excessively. A voltage above 10V will affect the horizontal oscillator function.

Band switching

Transistors Q306 to 308 are used to decode and buffer the 2 bandswitch pins (29 and 30).

Pin 29	Pin 30	VHF I	VHF III	UHF
LO	LO	-----	not valid	-----
LO	HI	X		
HI	LO		X	
HI	HI			X

Display Indicator

The 2 seven segment displays are driven in a multiplexed mode with the segments and digitals addressed sequentially.

The segments are controlled by pins 14-19, 21 and 22; the digits by pins 23 and 24.

To light a segment (eg. digit 1 segment C), pin 23 (digit enable) and pin 16 (segment C) must both be at 'low'.

Keyboard

The segment control lines that address the display are also used to scan the keyboard. When a key switch is pressed the closed contact is detected by the lines to pins 36-39.

Memory EEPROM

Various parameters such as tuning and bandswitch data, analogue settings as well as system options are stored in the EEPROM IC301. Either the MDA2061 or MDA2062 may be used.

The microcomputer SAA1293 communicates with EEPROM via a 3 wire IM bus. Data is transmitted or received in serial form and is stored as an 8 bit word. Total memory is 1024 bits (128 words).

An area of memory is protected and cannot be re-written unless pin 6 is high. This area is used for the operating options to ensure that false information or interference does not alter the operating system.

Infra-red preamplifier

The preamplifier module consists of a Infra-red PIN photodiode and a wideband preamplifier.

The TBA 2800 IC has four main parts: A gain controlled amplifier, 2nd stage amplifier, pulse separating amplifier and an inverter/driver. No adjustment is required.

Remote Control Transmitter

The SAA1250 IC transmits commands in the form of a 10 bit word. A total of 14 pulses are used for each word (activate, start, word and stop.) The time between pulses is used to signify the status of the bit (short delay '0', long delay for '1'). To provide immunity against interference the SAA1293 receiver must receive at least 2 identical words in sequence (the SAA1250 will continue to send the same word for as long as the key is pressed.)

When not transmitting the current consumption is kept to a minimum by the use of C-MOS technology.

Teletext control

A 2 line MI bus is used for data transmission and reception.

As the teletext decoder required a 3 line IM bus the AV switching output is programmed to operate as the IDENT line.

Section 4.5 - Tuning System, Fault Guide

- | | |
|--|--|
| 1. In standby, no display, no tuning functions | No 16V supply
Faulty 5V regulator IC302. |
| 2. Operating, no display, no tuning functions | No 12V supply
reset line low (pin 4 SAA1293A)
[Q302, Q305, D301] |
| 3. In standby, bar displayed, no tuning functions | Crystal X300 faulty. |
| 4. Displays (.1.) or (.2.), no programme memory | EEPROM IC301 faulty. |
| 5. Not memorising tuning positions or analogue settings All other functions normal | No 20V supply [D302, D303, C303] |
| 6. Not tuning. All other functions normal | No 33V [D001] - Q309 |
| 7. Tuning functions or display characters incorrect | Programmable tuning options not set. |

IMPORTANT. The operating and tuning characteristics are pre-programmed in the EEPROM. A suitably programmed EEPROM is only available from the service agents.

Section 4.6 - Tuning System, Parts List

Circuit Ref	Description	Part Number	Comment
R300	RESISTOR	CF 10K 0.25W	J 103116
R301	RESISTOR	CF 1K0 0.25W	J 102101
R302	RESISTOR	CF 10K 0.25W	J 103116
R303	RESISTOR	CF 330R 0.25W	J 101331
R304	RESISTOR	CF 10K 0.25W	J 103116
R305	RESISTOR	CF 12K 0.25W	J 103122
R306	RESISTOR	CF 3K9 0.25W	J 102397
R307	RESISTOR	CF 10K 0.25W	J 103116
R308	RESISTOR	CF 3K3 0.25W	J 102338
R309	RESISTOR	CF 10K 0.25W	J 103116
R310	NOT USED		
R311	RESISTOR	CF 10K 0.25W	J 103116
R313	RESISTOR	CF 4K7 0.25W	J 102479
R315	RESISTOR	CF 1K0 0.25W	J 102101
R316	RESISTOR	CF 1K5 0.25W	J 102157
R317	RESISTOR	CF 3K3 0.25W	J 102338
R318	RESISTOR	CF 4K7 0.25W	J 102479
R319	RESISTOR	CF 68K 0.25W	J 103686
R320	RESISTOR	CF 330K 0.25W	J 104332
R321	RESISTOR	CF 47K 0.25W	J 103475
R322	RESISTOR	CF 22K 0.25W	J 103224
R323	RESISTOR	CF 22K 0.25W	J 103224
R324	RESISTOR	CF 22K 0.25W	J 103224
R325	RESISTOR	CF 22K 0.25W	J 103224
R326	RESISTOR	CF 22K 0.25W	J 103224
R327	RESISTOR	CF 47K 0.25W	J 103475
R328	RESISTOR	CF 470K 0.25W	J 104470
R329	RESISTOR	CF 10K 0.25W	J 103216
R330	RESISTOR	CF 10K 0.25W	J 103116
R331	RESISTOR	CF 15K 0.25W	J 103155
R332	RESISTOR	CF 39K 0.25W	J 103392
R333	RESISTOR	CF 47K 0.25W	J 103475
R334	RESISTOR	CF 2K2 0.25W	J 102227
R335	RESISTOR	CF 220K 0.25W	J 101223
R336	RESISTOR	MF 33R 1W	J 110331
R337	RESISTOR	CF 1M0 0.25W	J 105106
R338	RESISTOR	CF 4K7 0.25W	J 102479
R339	RESISTOR	CF 4K7 0.25W	J 102479
R340	RESISTOR	CF 220R 0.25W	J 101223
R341	RESISTOR	CF 220R 0.25W	J 101223
R342	RESISTOR	CF 220R 0.25W	J 101223
R343	RESISTOR	CF 220R 0.25W	J 101223
R344	RESISTOR	CF 220R 0.25W	J 101223
R345	RESISTOR	CF 220R 0.25W	J 101223
R346	RESISTOR	CF 220R 0.25W	J 101223
R347	RESISTOR	CF 220R 0.25W	J 101223
R348	RESISTOR	CF 2K7 0.25W	J 105272
R349	RESISTOR	CF 1K8 0.25W	J 102189
R350	RESISTOR	CF 1K5 0.25W	J 102157
R356	RESISTOR	CF 4K7 0.25W	J 102479
C300	CAPACITOR	MKT 470n 63V	M 214485
C301	CAPACITOR	ELC 10u 50V	230143
C302	CAPACITOR	MKT 47n 100V	M 213485
C303	CAPACITOR	ELC 1u0 63V	239119
C304	CAPACITOR	MKT 100n 100V	M 214137
C306	CAPACITOR	MKT 100n 100V	M 214137
C307	CAPACITOR	MKT 100n 100V	M 214137
C308	CAPACITOR	CER 68n 50V	K 223682
C309	CAPACITOR	CER 68n 50V	K 223682

Circuit Ref	Description	Part Number	Comment
C310	CAPACITOR MKT 330n 63V	K 214336	
C311	CAPACITOR MKT 330n 63V	K 213336	
C312	CAPACITOR CER 470p 50V	K 221501	
C313	CAPACITOR MKT 470n 63V	M 214485	
C314	CAPACITOR MKT 220n 63V	M 214226	
C315	CAPACITOR MKT 100n 100V	M 214137	
C316	CAPACITOR CER 100p 50V	M 221175	
C322	CAPACITOR ELC 330u 16V	232331	
C323	CAPACITOR ELC 100u 16V	232161	
L300	COIL CHOKE 10u	052732	
D300	DIODE 1N4148	302289	
D301	DIODE ZPD5V6	302953	
D302	DIODE ZPD 20V	302954	
D303	DIODE 1N4148	302289	
D303	DIODE 1N4148	302289	
D304	DIODE 1N4148	302289	
D305	DIODE 1N4148	302289	
D306	DIODE 1N4148	302289	
D309	DIODE 1N4148	302289	
D310	DIODE ZPD 2V7	302448	
Q300	TRANSISTOR JA101	400902	
Q301	TRANSISTOR JA101	400902	
Q302	TRANSISTOR JA101	400902	
Q303	TRANSISTOR JA101	400902	
Q304	TRANSISTOR JC501	400921	
Q305	TRANSISTOR JC501	400921	
Q306	TRANSISTOR JA101	400922	
Q307	TRANSISTOR JA101	400922	
Q308	TRANSISTOR JA101	400922	
Q309	TRANSISTOR BF240	400926	
IC300	I.C. SAA1293A	451347	
IC301	I.C. MDA2062	451348	
IC302	I.C. L7805CV	451349	
X300	CRYSTAL 4.43MHz	056730	
	PCB, COMPLETE	597185	
Control board PCB			
R349	RESISTOR CF 39K 0.25W	J 103392	
R351	RESISTOR CF 240K 0.25W	J 104244	
R353	RESISTOR CF 33K 0.25W	J 103336	
	LED DISPLAY TDSR5130	302956	
	SWITCH TIP1550-600	010710	
	PCB, COMPLETE	577172	
Pre-amplifier PCB			
R354	RESISTOR CF 100R 0.25W	J 101106	
R355	RESISTOR CF 10K 0.25W	J 103116	
C316	CAPACITOR ELC 22u 16V	231260	
C317	CAPACITOR ELC 2u2 50V	239235	
C318	CAPACITOR CER 1n2 50V	J 222151	
C319	CAPACITOR CER 10n 50V	J 223138	
C320	CAPACITOR CER 10n 25V	J 223138	
D308	DIODE BPW41	302952	
IC303	I.C. TBA2800	451346	
	PCB, COMPLETE	597186	

SECTION 5.1 - AV BOARD, CIRCUIT DIAGRAM

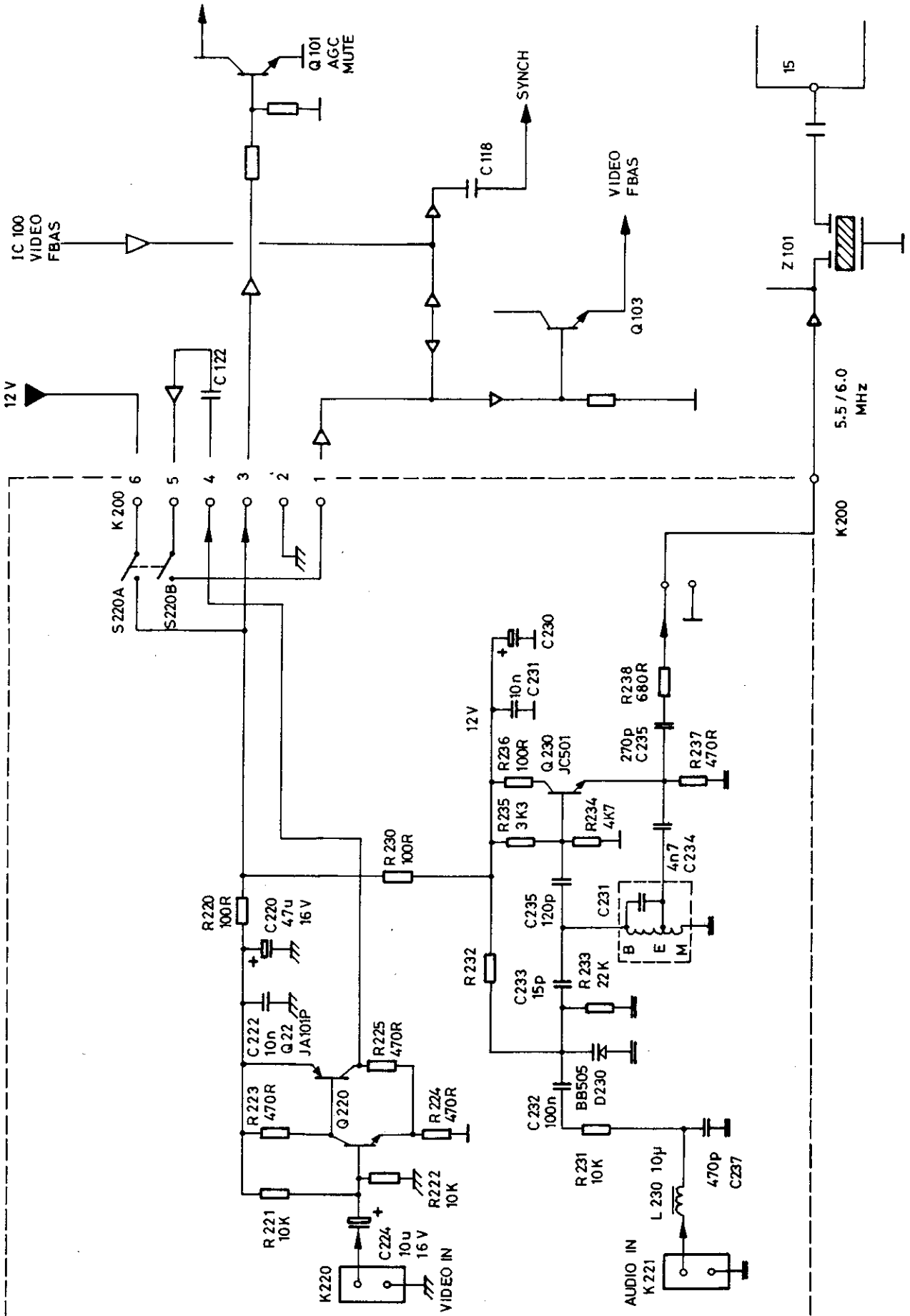

Section 5.1

SECTION 5.2 - AV BOARD, COMPONENT LOCATION

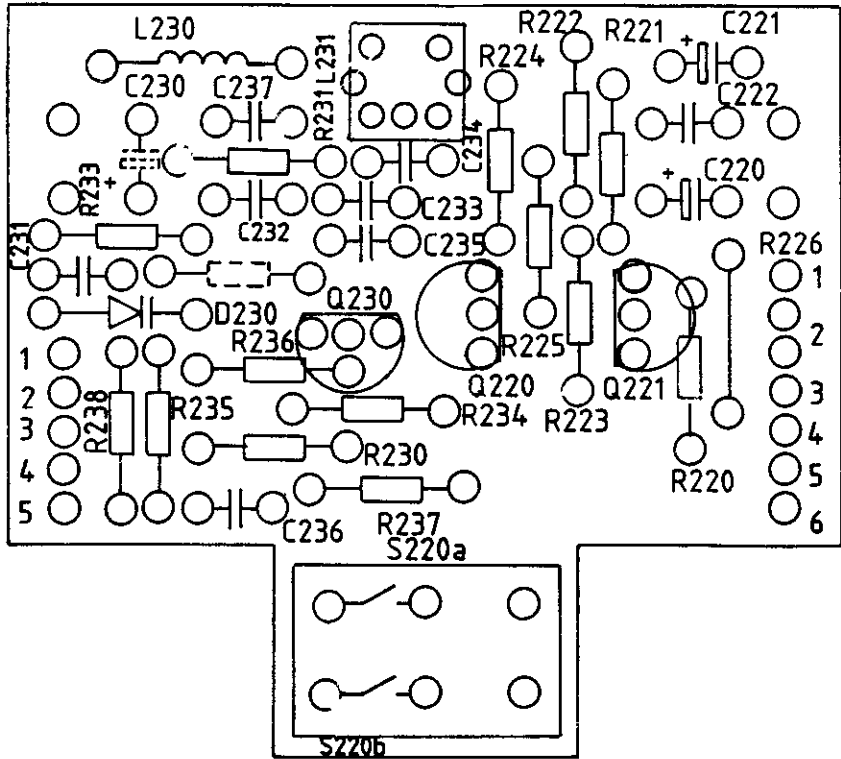

INSERTION DIAGRAM
AV - BOARD

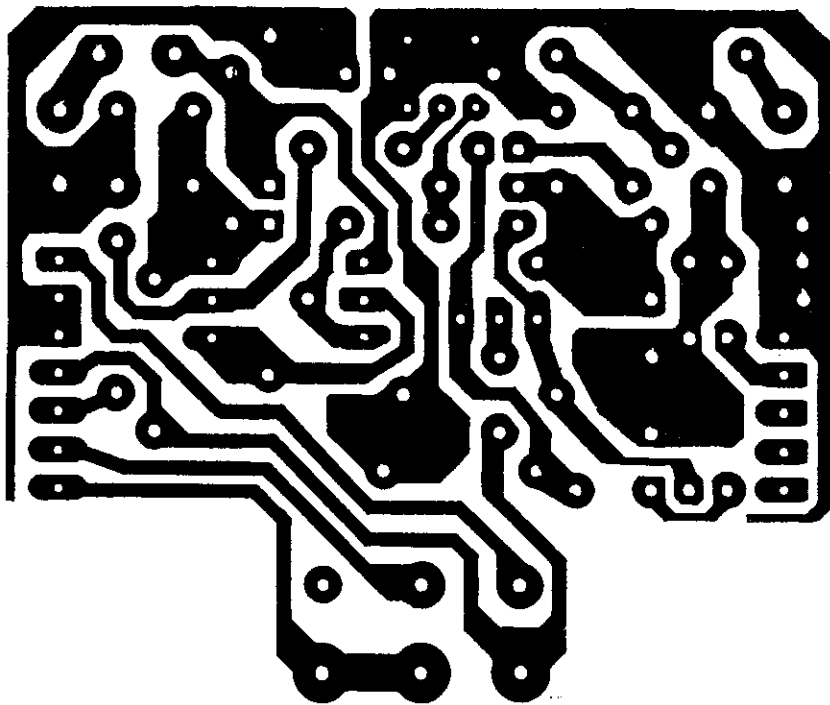

COPPER PATTERN

Section 5.3 - AV Interface, Description

Transistors Q220 and Q221 form a non-inverting amplifier with a gain of 2. A standard 1v p-p video signal is thus amplified to the same level as produced by the vision IF stage.

To allow the volume control to vary sound level, the audio from the AV socket must first be modulated (FM) so that it can be detected by the sound detector stages.

Transistor Q230 and inductor L231 form a Hartley oscillator which oscillates at the sound IF carrier frequency (5,5 or 6,0MHz).

The audio signal applied to the varicap diode D230 changes its capacitance and thus frequency modulates the oscillator circuit.

TV/AV switching is performed by the switch S220. In the AV mode transistor Q101 is turned on, connecting pin 19 (AGC detector) of TDA4505 to ground. This mutes the vision IF, however the sound IF remains unmuted.

Incoming video from Q220/Q221 is fed via pin 4 (K100) to the blocking capacitor C122.

Video for the synch detector passes through R138.

Video for the colour decoder returns through pin 5 and S220 to pin 1.

Section 5.4 - AV Interface, Alignment

Fitting/Removal

The module is connected to sockets K100 and K200. Remove or cut link J63 near Q103.

Note. Socket K100 is a 7 pin socket, 2 pins are used for ground (both marked pin 2).

Socket K200 is a 5 pin socket.

The 2 pin plug from the AV board must be fitted to the right side (pin 4 is input, pin 5 ground).

Alignment

Method 1.

Switch unit to AV.

Short circuit Audio input socket.

Connect frequency counter to R238 or plug K200 pin 4.

Adjust coil L231 for 5,5MHz (system B/G/H) or 6MHz (system I)

Method 2.

Inject a 1KHz 200mV audio signal into the AV socket.

Connect an oscilloscope to the loudspeaker.

Adjust L231 for maximum undistorted sound.

Increase the audio input level until distortion increases again, then readjust L231 for minimum distortion.

Section 5.5 - AV Interface, Parts List

Circuit Reference	Description				Part Number	Comment
R220 ▲	RESISTOR	CF	100R	0.25W	J	101106
R221	RESISTOR	CF	10K	0.25W	J	103116
R222	RESISTOR	CF	10K	0.25W	J	103116
R223	RESISTOR	CF	470R	0.25W	J	101470
R224	RESISTOR	CF	470R	0.25W	J	101470
R225	RESISTOR	CF	470R	0.25W	J	101470
R230 ▲	RESISTOR	CF	100R	0.25W	J	101106
R231	RESISTOR	CF	10K	0.25W	J	103116
R233	RESISTOR	CF	22K	0.25W	J	103224
R234	RESISTOR	CF	4K7	0.25W	J	102479
R235	RESISTOR	CF	3K3	0.25W	J	102338
R236	RESISTOR	CF	100R	0.25W	J	101106
R237	RESISTOR	CF	470R	0.25W	J	101470
R238	RESISTOR	CF	680R	0.25W	J	101683
R239	RESISTOR	CF	75R	0.25W	J	100751
C220	CAPACITOR	ELC	47u	16V		230509
C221	CAPACITOR	ELC	10u	16V		230143
C222	CAPACITOR	CER	10n	25V	M	223138
C231	CAPACITOR	CER	10n	25V	M	223138
C232	CAPACITOR	MKT	100n	100V	M	214137
C233	CAPACITOR	CER	33p	50V	J	220247
C234	CAPACITOR	CER	4n7	50V	K	222480
C235	CAPACITOR	CER	120p	50V	J	221173
C236	CAPACITOR	CER	270p	50V	J	221279
C237	CAPACITOR	CER	470p	50V	J	221494
D230	DIODE	BB329				302693
K220	SOCKET AV	S101-A				031777
S220	SWITCH AV	TK1				010711
L230	COIL	CHOKE	10u			052726
L231	COIL	421				052691
Q220	TRANSISTOR	JC501				400921
Q221	TRANSISTOR	JA101				400920
Q230	TRANSISTOR	JC501				400921
	PCB, COMPLETE					597175

SECTION 6.3 - SECAM TRANSCODER, BLOCK DIAGRAM

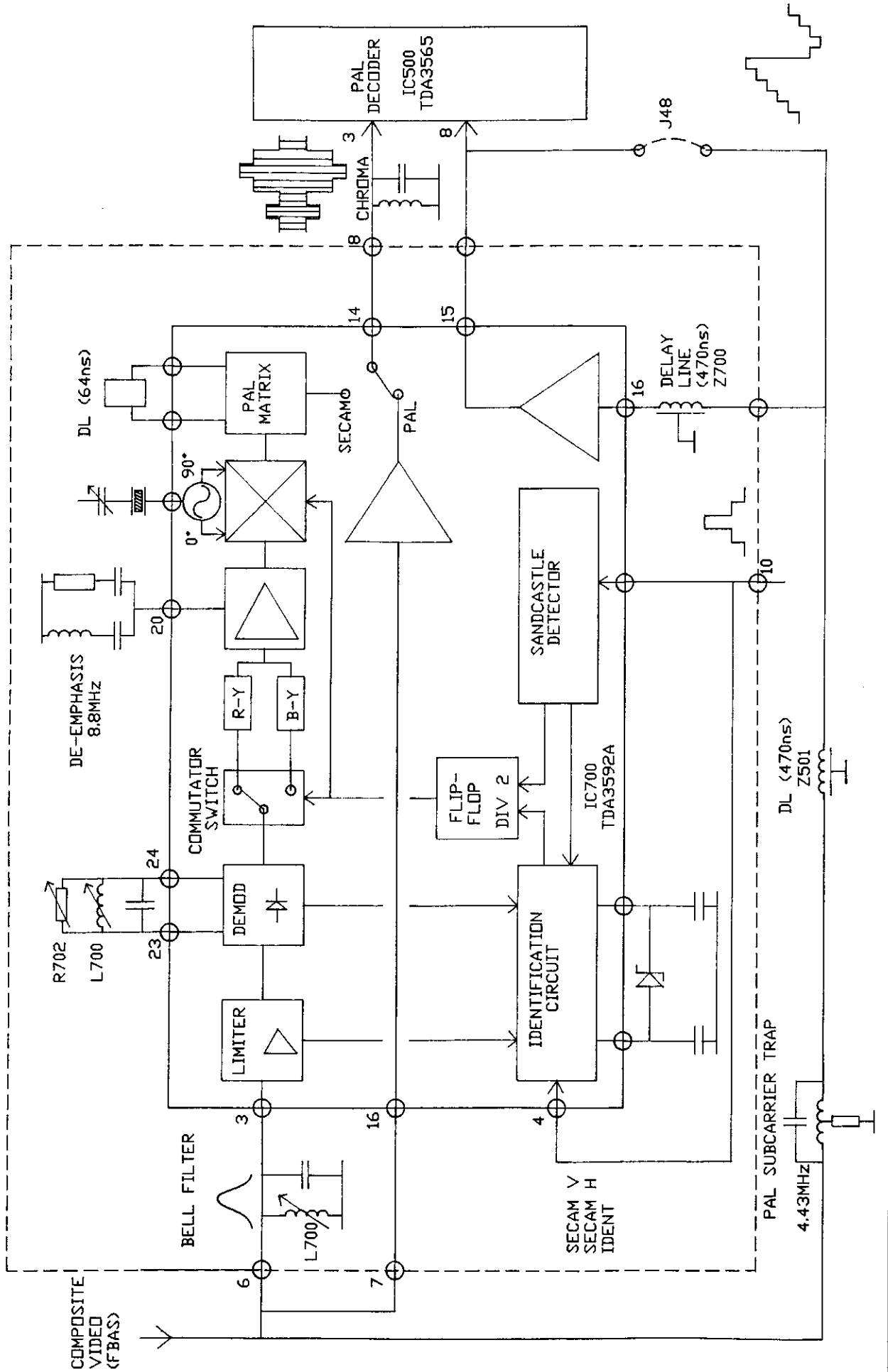

Section 6.3

Section 6.4 - SECAM Transcoder, Description

The TDA3592A integrated circuit consists of a SECAM decoder, PAL encoder and automatic PAL/SECAM switching.

If a SECAM signal is detected it is decoded as (R-Y) and (B-Y) signals before being re-encoded as PAL.

For any other signal which is not SECAM (ie PAL, Monochrome, NTSC or no signal) the IDENTIFICATION circuit allows the signal to pass through the transcoder without any processing.

SECAM signals with vertical identification (SECAM-V) or with horizontal identification (SECAM-H) can be decoded.

The SECAM system transmits colour information as FM modulated colour difference signals. The signals are sequential; (R-Y) for one horizontal line and (B-Y) for the next. To enable the colour difference signals to be identified the (R-Y) signal has a centre frequency of 4,406MHz and the (B-Y) signal 4,25MHz.

The SECAM signal passes through the Bell (cloche) filter to pin 3. The Bell filter is tuned to approximately 4,43MHz and equalises the amplitude of the 2 signals. Some compensation for frequency response errors in the vision IF stages is also possible.

The SECAM signal passes through a FM limiting amplifier before being demodulated. To allow black level clamping the (R-Y) and (B-Y) signals must be separated by the commutating switch. After clamping the signals are recombined in an amplifier which has an external de-emphasis circuit. Pin 20.

The (R-Y) and (B-Y) signals are used to amplitude modulate the 2 subcarrier (4,43MHz) signals.

As the (B-Y) and (R-Y) +/-90 signals still alternate line by line the delay line DL701 and PAL matrix are used to produce a normal PAL signal.

Section 6.5 Secam Transcoder, Alignment

FITTING/REMOVAL

Break links T49 (chroma) and J48 (Luma), fit transcoder to socket and secure with screw.
Refit links if transcoder is to be removed.

ALIGNMENT

Bell filter

Tune to a SECAM colourbar signal.

Connect an oscilloscope via a low capacitance probe (<2.5pF) to pin 3.

Adjust the bell filter L702 so that the amplitudes of the R-Y (4,406MHz) and B-Y (4,25MHz) signals are equal. (See fig 1.)

Another method is to view the signal at pin 20 on the oscilloscope and adjust for optimum step response.

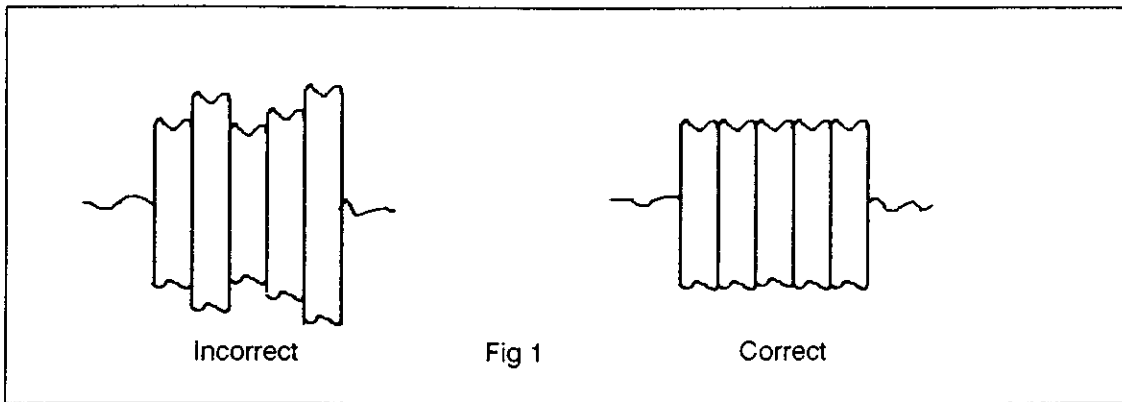

PAL reference oscillator

Method 1:

Connect a frequency counter via a low capacitance probe to pin 8.

Adjust the trimmer capacitor C717 for a frequency of 4.433619MHz +/-50Hz.

Method 2:

Override the colour killer and ident circuits of the PAL decoder to put the oscillator in the free running mode. (See section on PAL decoder alignment.)

Tune to a PAL colour bar signal.

Adjust the oscillator of the PAL decoder for stationary colours.

Change the PAL signal for a SECAM signal.

Adjust trimmer capacitor C717 for stationary colours again.

SECAM demodulator reference circuit

Use a SECAM chrominance signal without colour modulation. (Unmodulated 4,406 and 4,25MHz).

Connect an oscilloscope via a low capacitance probe to IC700 pin 9.

Align L700 and R702 for minimum amplitude modulation of the signal.

Chromanence delay line

Note. The PAL decoder, the BELL filter (L702) and the demodulator circuit must be correctly aligned before adjusting the delay line.

Method 1:

This method makes use of a SECAM generator which is able to modulate the B-Y carrier only.

Adjust the potentiometer (R717) amplitude and the coils L702 and L704 (delay line phase) for a minimum (R-Y) signal in the PAL decoder.

Method 2:

Connect a PAL vectorscope to the output of the transcoder (pin 8).

Ensure correct PAL vector graticule is fitted.

Supply a SECAM colour-bar signal to the input circuit of the IC.

Adjust coils (L702 and L704) and preset potentiometer R711 amplitude until the vectors are of correct phase and amplitude. Use the BLUE signal as the reference vector.

Section 6.6 - SECAM Transcoder, Parts List

Circuit Reference	Description	Part Number	Comment
R700	RESISTOR CF 1K0 0.25W	J 102101	
R701	RESISTOR CF 1K0 0.25W	J 102101	
R702	PRESET HRZ 1K0 5x10mm	132100	
R703	RESISTOR CF 560R 0.25W	J 101562	
R704	RESISTOR CF 2K0 0.25W	J 000000	
R705	RESISTOR CF 10R 0.25W	J 100107	
R708	RESISTOR CF 2K0 0.25W	J 111111	
R709	RESISTOR CF 1K0 0.25W	J 102101	
R710	RESISTOR CF 390R 0.25W	J 101395	
R711	PRESET HRZ 1K0 5x10mm	132100	
R712	RESISTOR CF 680R 0.25W	J 101683	
C700	CAPACITOR PYF 180p 63V	G 221192	
C701	CAPACITOR MKT 100n 100V	M 214137	
C702	CAPACITOR MKT 100n 100V	M 214137	
C703	CAPACITOR CER 1n0 50V	K 224108	
C704	CAPACITOR CER 33p 50V	K 220347	
C705	CAPACITOR ELC 1u0 50V	239128	
C706	CAPACITOR ELC 10u 16V	230143	
C707	CAPACITOR CER 22n 50V	M 223247	
C710	CAPACITOR CER 100p 50V	M 221175	
C711	CAPACITOR PYF 390p 63V	G 221391	
C712	CAPACITOR MKT 100n 100V	M 214137	
C713	CAPACITOR MKT 100n 100V	M 214137	
C714	CAPACITOR MKT 100n 100V	M 214137	
C715	CAPACITOR TANT 1u0 25V	M	
C716	CAPACITOR ELC 1u0 50V	239128	
C717	CAPACITOR TRIMMER 22p 7.5mm	260225	
C718	CAPACITOR CER 10n 50V	K 223135	
C719	CAPACITOR CER 1n0 50V	K 224108	
C720	CAPACITOR CER 1n0 50V	K 224108	
C721	CAPACITOR CER 1n0 50V	K 224108	
L700	COIL 566	052703	
L701	COIL CHOKE 10u	052726	
L702	COIL 564	052133	
L703	COIL CHOKE 12u	053321	
L704	COIL CHOKE 12u	053321	
Z700	DELAY LINE DL470	052702	
Z701	DELAY LINE DL701	052701	
X700	CRYSTAL 4,43 MHz	056730	
D700	DIODE BAW76	302955	
IC700	I.C. TDA3592A	451350	
	PCB, COMPLETE	597158	

SECTION 7.1 - TELETEXT SYSTEM, CIRCUIT DIAGRAM

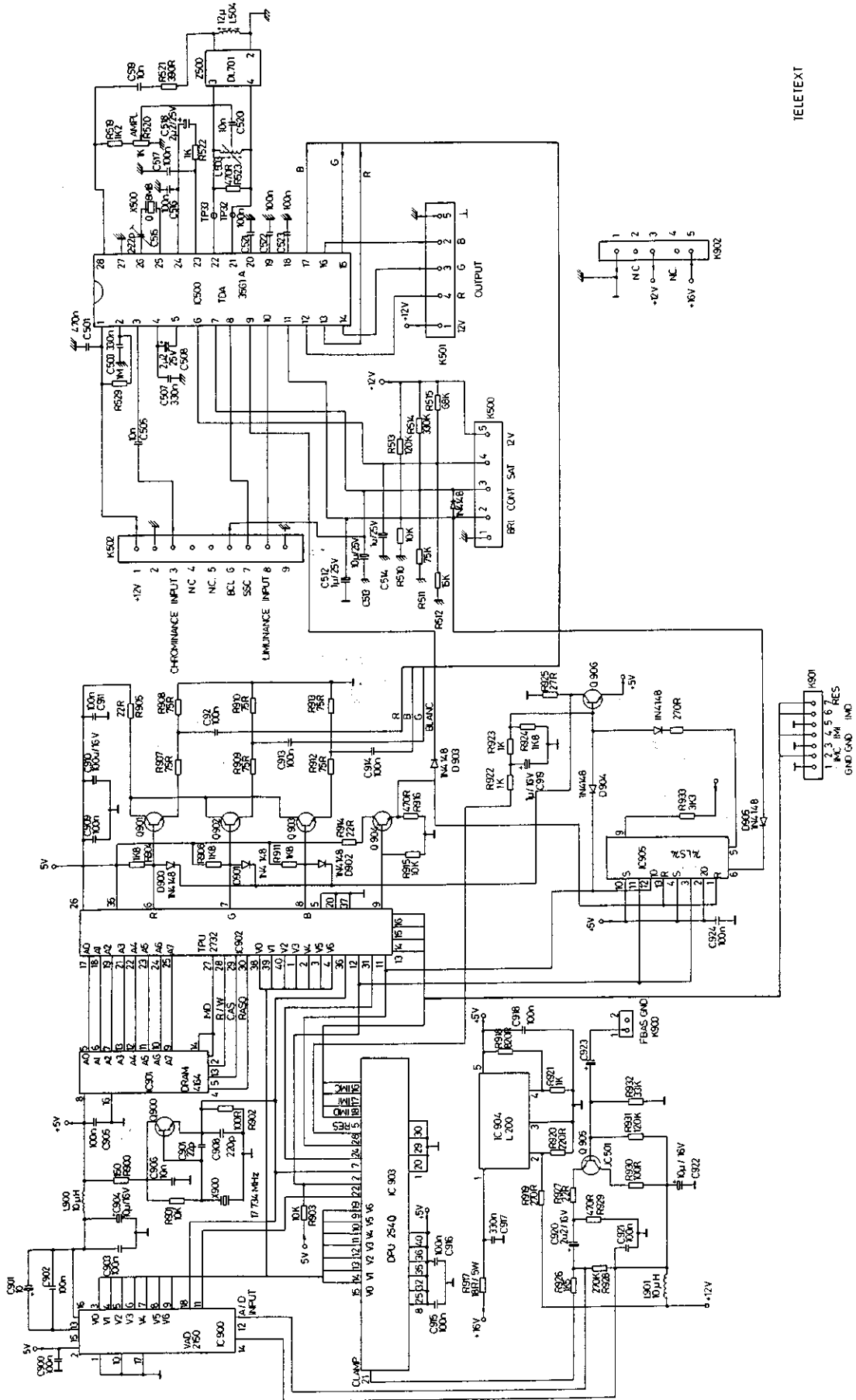

SECTION 7.2 - TELETEXT SYSTEM, COMPONENT LOCATION

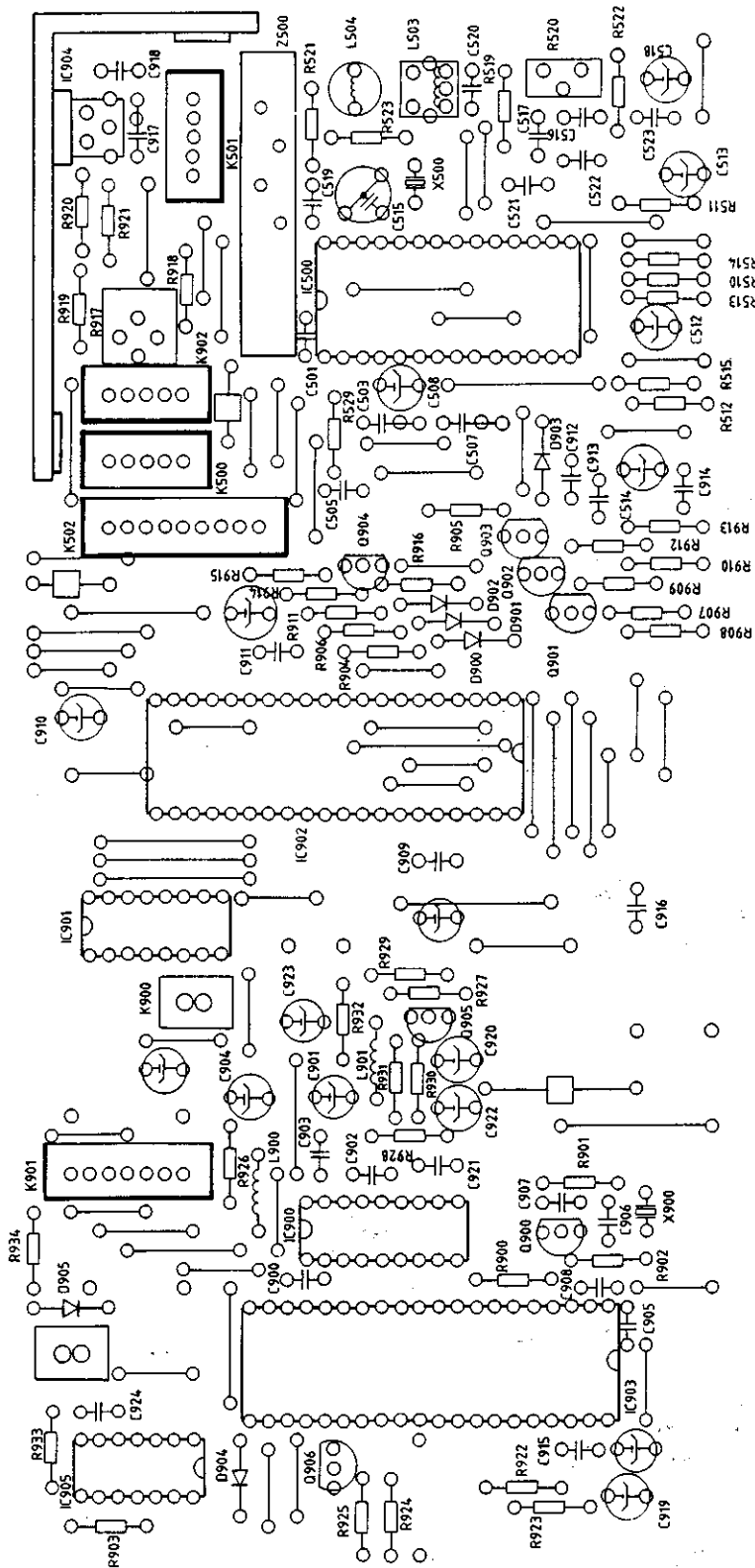

●
INSERTION DIAGRAM
TELETEXT 19 - 10 - 88

SECTION 7.3 - TELETXT SYSTEM, BLOCK DIAGRAM

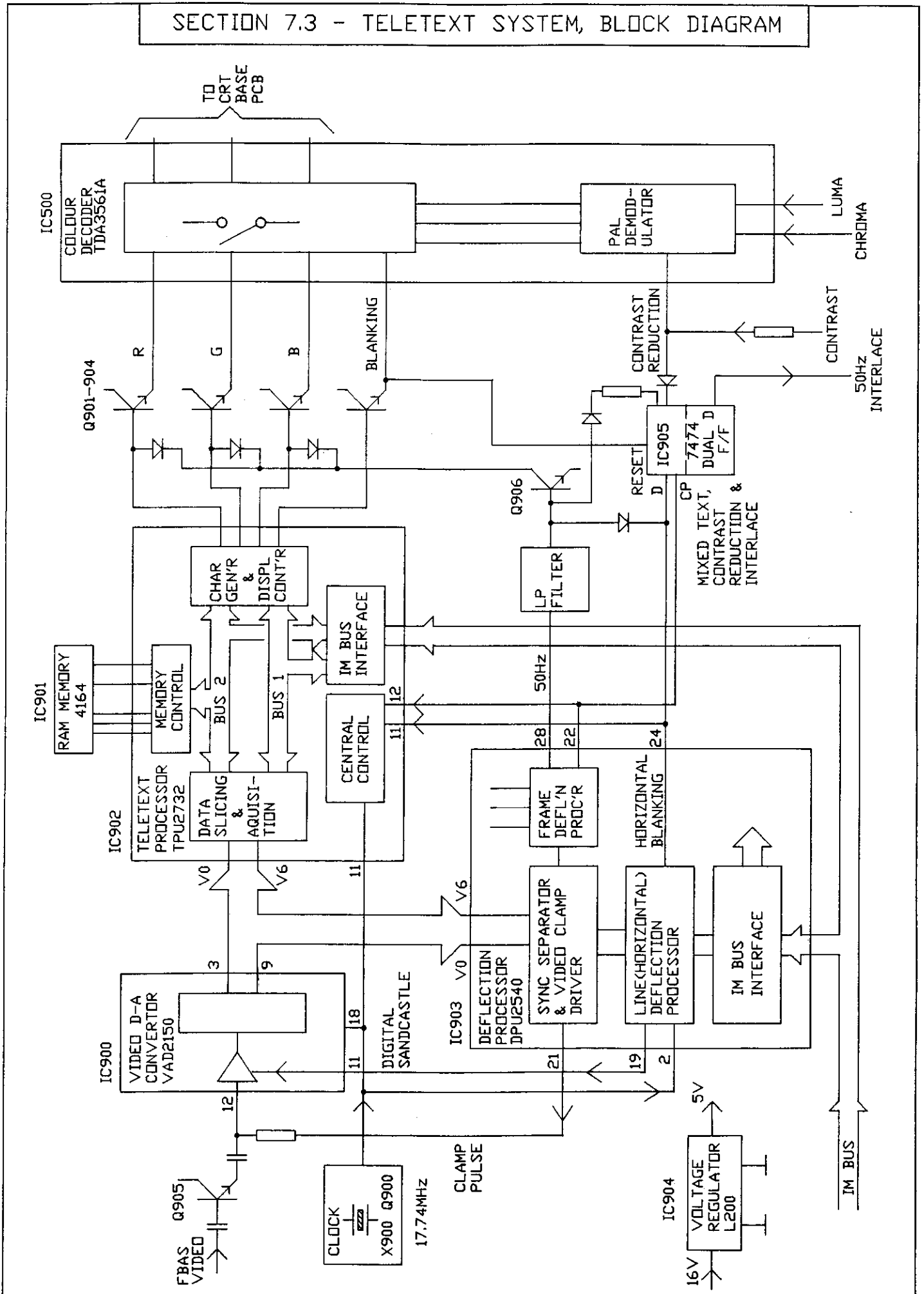

Section 7.3

Section 7.4 - Teletext System, Description

For teletext models the existing colour decoder on the main PCB is replaced with a new decoder on the teletext PCB.

Circuit description

The composite (FBAS) video signal is converted into a 7bit digital signal by the A to D flash convertor IC900 (VAD2150). Transistor Q905 provides a low impedance drive for the convertor's input (pin12) as well as preventing the clamp pulses from IC903 entering the video signal line.

A digital sandcastle pulse from IC903 is used to blank the synchronising pulses and colour burst (pin 11).

All the teletext decoding and character generation is performed within the teletext processor IC902 (TPU2732). No adjustments or alignment are necessary.

For mixed text mode the vertical deflection circuit is provided with a fully interlaced 50Hz signal via a bistable (flip-flop) in IC905.

Contrast reduction is also necessary to prevent the beam current limiter circuit acting when in mixed text mode. This is achieved by triggering another bistable in IC905.

Note: Fitting a teletext board to a non teletext chassis may contravene safety regulations and will invalidate the guarantee.

For Service Manuals
MAURITRON SERVICES
8 Cherry Tree Road, Chinnor
Oxfordshire, OX9 4QY.
Tel (01844) 351694
Fax (01844) 352554
email:- sales@mauritron.co.uk

Section 7.5 - Teletext system, Alignment

Teletext decoder

No alignment necessary.

Colour decoder

Colour reference oscillator

Tune to a PAL colour bar pattern.

Connect test points TP32 and TP33 together. (Pins 21 and 22 of IC500)

Connect pin6 (SAT) to +12V to override the colour killer.

Adjust trimmer capacitor C515 for minimum rolling of colour bars.

PAL matrix adjustment

Tune to a PAL colour bar signal that has anti PAL (colourless) areas.

Method 1

Connect an oscilloscope to the BLUE output (connector K501 pin 2).

Adjust the delay line amplitude (DL-AMP) preset R520 and delay line phase (DL-P) coil L503 to minimise the alternating (double waveform. (see figs 1 and 2 section 3.5)

Method 2

Connect an oscilloscope with X and Y inputs to the RED and BLUE outputs.

(X to K501 pin 4 RED, Y to K501 pin 2 BLUE)

Adjust colour, brightness and contrast controls to produce a vector display on the oscilloscope (see Fig 3 section 3.5).

Adjust DIL-AMP preset to reduce the amplitude of the small vectors (hannover blind errors), and the DL-PHASE coil to superimpose the output vectors (see fig 4 section 3.5).

Note: Some test patterns may not produce clearly visible vectors.

Chroma band pass filter L500

See alignment details in non teletext version (section 3.5)

Chroma trap L501.

See alignment details in non teletext version (section 3.5)

Section 7.6 - Teletext System, Fault Guide

System does not enter into the text mode.

Check power supply (IC904).
Check clock circuit (Q900).
Check blanking output (Q904).
Check RAM memory (IC901).
Check colour decoder (IC500).
Check teletext operating options. *

System enters into an unidentified mode.
(Neither teletext nor TV mode)

Check/replace TPU2732 (IC902).
Check/replace 4164 (IC901).
Check teletext operating options. *

System enters into teletext mode but does not display teletext information.

If no page header:
Check R,G,B outputs, and IC902..
If page header ok but no other information :
Check video input, Q905 and IC903.
Check teletext operating options. *

Text displayed on the screen is not synchronised.

Check waveforms and synchronisation signal outputs (pins 22 and 24 of IC903 DPU2540).
Note: There is no after hours synch (AHS).
Text will not be synchronised unless a TV signal is being received.

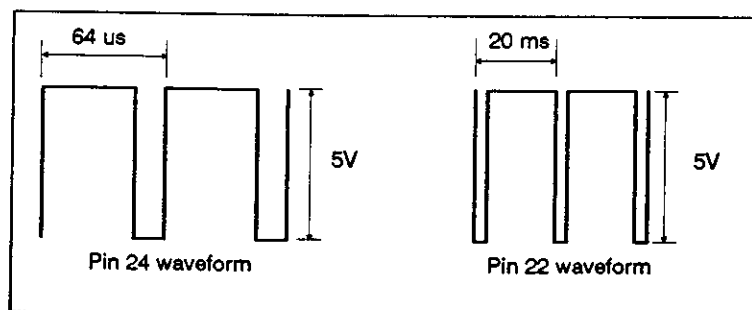

Errors, faulty characters or decoding errors.

Check 'clock cracker' pages from several different stations.
If pages vary significantly or are random check:
I.F. alignment.
Level of video (FBAS) signal at base of Q905
Clamp pulses from IC903 pins 19 & 21.
Check/replace IC900 & IC903.
If errors remain constant or characters distorted check/replace IC901 or IC902..

Excessive contrast of teletext characters.

Check the voltage level (4V) at pin 28 of IC903 and Q906.

Check value of R924 (1k5-2k2).

Check EEPROM (IC300) program.

Excessive contrast of teletext character in mixed text mode.

Check pin 5 of IC905. (Low in TV or mixed text mode.

Interlace flicker on text display.

Check the waveform at pin 9 of IC905.

(25Hz square wave when in teletext mode)

Note:

No output when in TV or mixed text mode.

* Teletext operating options (teletext system, language, contrast level etc) are stored in the tuning system EEPROM IC300.

For Service Manuals
MAURITRON SERVICES
8 Cherry Tree Road, Chinnor
Oxfordshire, OX9 4QY.
Tel (01844) 351694
Fax (01844) 352554
email:- sales@mauritron.co.uk

Section 7.7 - Teletext System, Parts List

Circuit Reference	Description	Part Number	Comment
R510	RESISTOR CF 10K 0.25W	J 103116	
R511	RESISTOR CF 75K 0.25W	J 103752	
R512	RESISTOR CF 15K 0.25W	J 103155	
R513	RESISTOR CF 120K 0.25W	J 104123	
R514	RESISTOR CF 330K 0.25W	J 104332	
R515	RESISTOR CF 68K 0.25W	J 103686	
R519	RESISTOR CF 1K2 0.25W	J 102126	
R520	PRESET HRZ 1K 5x10mm	132122	
R521	RESISTOR CF 390R 0.25W	J 101395	
R523	RESISTOR CF 1K0 0.25W	J 102101	
R524	RESISTOR CF 470R 0.25W	J 104470	
R900	RESISTOR CF 150R 0.25W	J 101154	
R901	RESISTOR CF 10K 0.25W	J 103116	
R902	RESISTOR CF 100R 0.25W	J 101106	
R903	RESISTOR CF 10K 0.25W	J 103116	
R904	RESISTOR CF 1K8 0.25W	J 102189	
R905	RESISTOR CF 22R 0.25W	J 100224	
R906	RESISTOR CF 1K8 0.25W	J 102189	
R907	RESISTOR CF 75R 0.25W	J 100751	
R908	RESISTOR CF 75R 0.25W	J 100751	
R909	RESISTOR CF 75R 0.25W	J 100751	
R910	RESISTOR CF 75R 0.25W	J 100751	
R911	RESISTOR CF 1K8 0.25W	J 102189	
R912	RESISTOR CF 75R 0.25W	J 100751	
R913	RESISTOR CF 75R 0.25W	J 100751	
R914	RESISTOR CF 22R 0.25W	J 100224	
R915	RESISTOR CF 10K 0.25W	J 103116	
R916	RESISTOR CF 470R 0.25W	J 104470	
R917	RESISTOR WW 18R 5W	K 120180	
R918	RESISTOR CF 820R 0.25W	J 101820	
R919	RESISTOR CF 270R 0.25W	J 101274	
R920	RESISTOR CF 220R 0.25W	J 101223	
R921	RESISTOR CF 1K0 0.25W	J 102101	
R922	RESISTOR CF 1K0 0.25W	J 102101	
R923	RESISTOR CF 1K0 0.25W	J 102101	
R924	RESISTOR CF 1K8 0.25W	J 102189	
R925	RESISTOR CF 27R 0.25W	J 100271	
R926	RESISTOR CF 1K5 0.25W	J 102157	
R927	RESISTOR CF 22R 0.25W	J 100224	
R928	RESISTOR CF 270K 0.25W	J 104273	
R929	RESISTOR CF 470R 0.25W	J 104470	
R930	RESISTOR CF 100R 0.25W	J 104110	
R931	RESISTOR CF 120K 0.25W	J 104123	
R932	RESISTOR CF 33K 0.25W	J 103336	
R933	RESISTOR CF 3K3 0.25W	J 102338	
R934			
R935	RESISTOR CF 270-820R 0.25W	J 101274	Replaced by link
C501	CAPACITOR MKT 470n 63V	K 214494	Value sets mixed teletext contrast level
C503	CAPACITOR MKT 330n 63V	K 214336	
C505	CAPACITOR CER 10n 50V	K 223135	
C507	CAPACITOR MKT 330n 63V	K 214336	
C508	CAPACITOR ELC 2u2 50V	K 239235	
C512	CAPACITOR ELC 1u0 50V	293128	
C513	CAPACITOR ELC 10u 16V	230143	
C514	CAPACITOR ELC 1u0 50V	239128	
C515	CAPACITOR TRIM 22p 7.5mm	260225	
C516	CAPACITOR MKT 100n 100V	M 214137	
C517	CAPACITOR MKT 100n 100V	M 214137	
C518	CAPACITOR ELC 2u2 50V	239235	
C519	CAPACITOR CER 10n 50V	K 223135	
C520	CAPACITOR CER 10n 50V	K 223135	

Circuit Reference	Description	Part Number	Comment
C521	CAPACITOR MKT 100n 100V	M 214137	
C522	CAPACITOR MKT 100n 100V	M 214137	
C523	CAPACITOR MKT 100n 100V	M 214137	
C900	CAPACITOR MKT 100n 100V	M 214137	
C901	CAPACITOR ELC 10u 16V	230143	
C902	CAPACITOR MKT 100n 100V	M 214137	
C903	CAPACITOR MKT 100n 100V	M 214137	
C904	CAPACITOR ELC 10u 16V	230143	
C905	CAPACITOR MKT 100n 100V	M 214137	
C906	CAPACITOR CER 10n 50V	M 223135	
C907	CAPACITOR CER 22p 50V	J 220246	
C908	CAPACITOR CER 220p 50V	M 221245	
C909	CAPACITOR MKT 100n 100V	M 214137	
C910	CAPACITOR ELC 10u 16V	230143	
C911	CAPACITOR MKT 100n 100V	M 214137	
C912	CAPACITOR MKT 100n 100V	M 214137	
C913	CAPACITOR MKT 100n 100V	M 214137	
C914	CAPACITOR MKT 100n 100V	M 214137	
C915	CAPACITOR MKT 100n 100V	M 214137	
C916	CAPACITOR MKT 100n 100V	M 214137	
C917	CAPACITOR MKT 330n 63V	K 214336	
C918	CAPACITOR MKT 330n 63V	K 214336	
C919	CAPACITOR ELC 1u0 50V	239128	
C920	CAPACITOR ELC 2u2 50V	239235	
C921	CAPACITOR MKT 100n 100V	M 214137	
C922	CAPACITOR ELC 10u 16V	230143	
C923	CAPACITOR ELC 1u0 50V	239128	
C924	CAPACITOR MKT 100n 100V	M 214137	
C925	CAPACITOR CER 10n 50V	M 223135	
D900	DIODE 1N4148	302289	
D901	DIODE 1N4148	302289	
D902	DIODE 1N4148	302289	
D903	DIODE 1N4148	302289	
D904	DIODE 1N4148	302289	
D905	DIODE 1N4148	302289	
D906	DIODE 1N4148	302289	
D907	DIODE 1N4148	302289	
D908	DIODE 1N4148	302289	
Q900	TRANSISTOR JC501	400920	
Q901	TRANSISTOR JC501	400920	
Q902	TRANSISTOR JC501	400920	
Q903	TRANSISTOR JC501	400920	
Q904	TRANSISTOR JC501	400920	
Q905	TRANSISTOR JC501	400920	
Q906	TRANSISTOR JC501	400920	
IC500	I.C. TDA3561A	451390	
IC900	I.C. VAD2150	451393	
IC901	I.C. DRAM 4164	451396	
IC902	I.C. TPU2732	451394	
IC903	I.C. DPU2540	451395	
IC904	I.C. L200CV	451391	
IC905	I.C. 74LS74	451392	
L503	COIL PAL DELAY PHASE 412	052695	
L504	COIL CHOKE 12u	053321	
L900	COIL CHOKE 10u	052726	
L901	COIL CHOKE 10u	052726	
Z500	COIL PAL DELAY LINE DL701	052701	
X500	CRYSTAL 8.867MHz	056729	
X900	CRYSTAL 17.73447MHz	056860	
	PCB, COMPLETE	597196	

Section 8 - CRT Purity and Convergence

IMPORTANT.

The purity and convergence have been pre-aligned and should not normally require adjustment.

If purity or convergence is incorrect check the operation of the degaussing coil and thermistor R804 before attempting any adjustment.

The Philips tube has the purity and convergence preset by magnetised rings within the picture tube neck. Do not allow magnetised objects, external degaussing coils or magnets near the tube neck otherwise purity or convergence may be affected permanently.

Alignment procedures vary according to the size and make of tube. Before commencing any adjustment demagnetise the tube and cabinet with an external degaussing coil. Allow the receiver to operate for 15 minutes.

Conventional PIL Tube

14inch (37cm) Samsung 3708B22

20inch (51cm) Samsung 5109B22

Colour Purity and Centre Convergence

1. Obtain a green raster by turning down the RED (R) and BLUE (B) background (cut off) presets or by selecting a green test pattern.
2. Loosen the clamp screw holding the yoke and slide the yoke backward to provide vertical green bar (zone) in the picture screen. (Fig. 2.)
3. Remove the rubber wedges. (If fitted).
4. Rotate and spread the tabs of the purity (P) magnet (Fig. 1.) until the green bar is in the centre of the screen. At the same time, centre the raster vertically.
5. Move the yoke slowly forward until a uniform green screen is obtained. Place a rubber wedge in the uppermost position (D). Lightly tighten the clamp screw of the yoke.
6. Check the purity of the red and blue rasters by adjusting the background (cut off) presets.
7. Adjust the background (cut off) presets for a white raster.
8. Select crosshatch pattern on signal generator. Adjust the BRIGHTNESS, CONTRAST and FOCUS controls for a well defined pattern.
9. Turn the green gun off with the background (cut off) preset.
10. Adjust the two tabs of the 4-pole magnets to converge the red and blue vertical lines in the centre of the picture screen. (Fig 4.)
Turning both tabs together moves the red and blue lines vertically.
Turning each tab in opposite directions moves the red and blue lines horizontally.
11. Turn the green gun on. Adjust the two tabs of 6-pole magnets to converge the red/blue and green lines. The 6 pole magnets move the red/blue and green lines the same way as the 4 pole magnets.
12. Repeat the convergence and purity adjustments bearing in mind that the adjustments interact to some extent.

Peripheral (dynamic) Convergence

1. Remove any wedges that may be fitted.
2. Tilt front of the deflection yoke up or down to obtain best convergence at the edge of the screen (Fig .5). Place a wedge at the uppermost position (D). Do not remove the adhesive backing paper from the wedge.
3. Place the other wedge at the bottom position (B) removing the backing paper to stick.
4. Tilt front of the yoke right or left to obtain best convergence of parallel lines. (Fig. 6.)
5. Keep the yoke position steady and put another wedge in either upper position (A or C). Remove backing paper and stick the wedge on the picture tube.
6. Remove the temporary wedge and fit it in the other upper position. Stick it to the picture tube to secure the yoke.
7. After fixing the three wedges, recheck overall convergence and purity. Tighten the screw firmly to fix the yoke and check the yoke is firm.
8. Secure the wedges with additional tape, silicon rubber or other flexible adhesive.

FST (S5) Picture Tube

21inch (53cm) Videocolor A51EBV12X

Purity and static convergence are adjusted by the magnetic ring on the tube neck. The ring can be rotated or moved along the neck.

PERIFERAL (DYMANIC) CONVERGENCE

1. Retract the 3 adjustment screws by rotating them anti clockwise.
2. Obtain a green raster by turning down the red (R) and blue (B) background (cut off) presets or selecting a green test pattern.
3. Move the yoke backwards or forwards until a uniform green screen is obtained. Tighten the clamp screw lightly.
4. Adjust the background controls for a white raster.
5. Select a crosshatch pattern and check that the lines are converged correctly at the centre of the screen. The position of the yoke may have to moved slightly to obtain optimum purity and convergence.
6. Peripheral convergence procedure is similar to that for the PIL tubes.
Move the yoke in the horizontal or vertical plane to converge the red/green/blue lines at the edges of the screen. (Figs. 5 & 6.)
7. Rotate the adjustment screws clockwise until they touch the glass. Tighten the clamp screw firmly.
8. Using a plastic adjustment tool, tighten the screws gradually to obtain best convergence and to prevent the scan coil moving. Do not over tighten otherwise the yoke will move backwards affecting purity.
9. Secure the ends of the adjustment screws to the glass with silicon rubber or other flexible adhesive.

FST (45AX) Picture Tube

15inch (38cm) Philips A36EAM00X01

21inch (53cm) Philips A51EAL00X

No purity or convergence adjustments are necessary.

SECTION 8 - CRT PURITY & CONVERGENCE

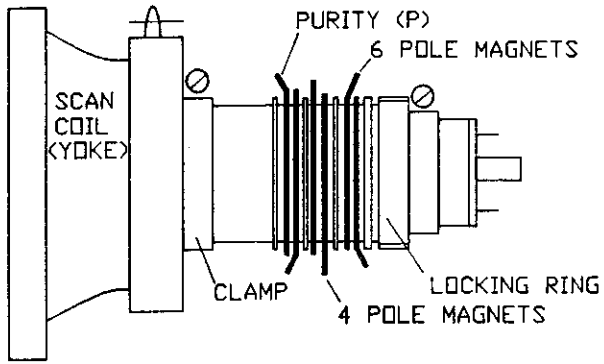

FIG 1

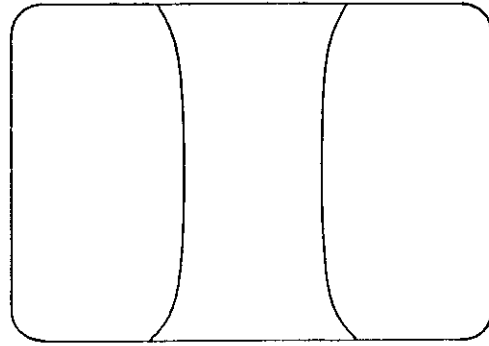

FIG 2

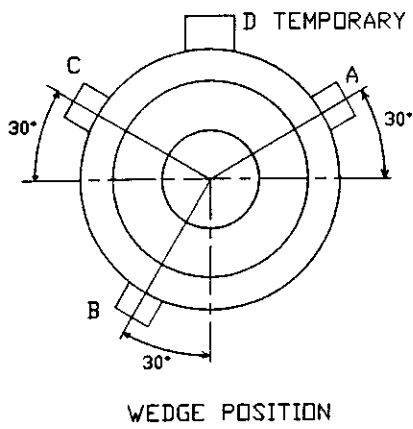

FIG 3

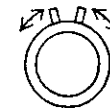
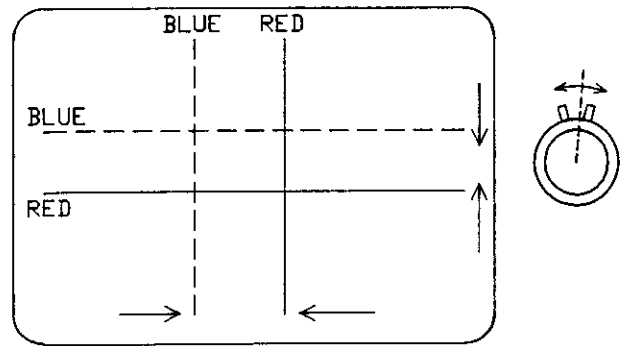

FIG 4

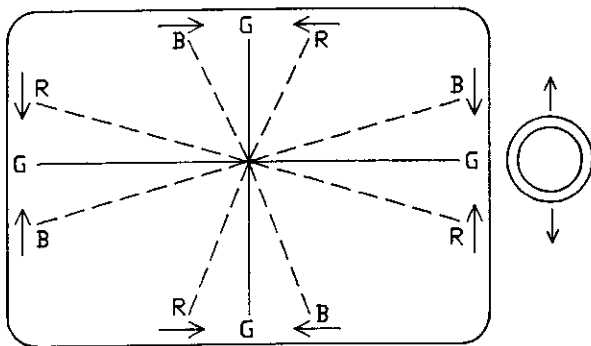

FIG 5

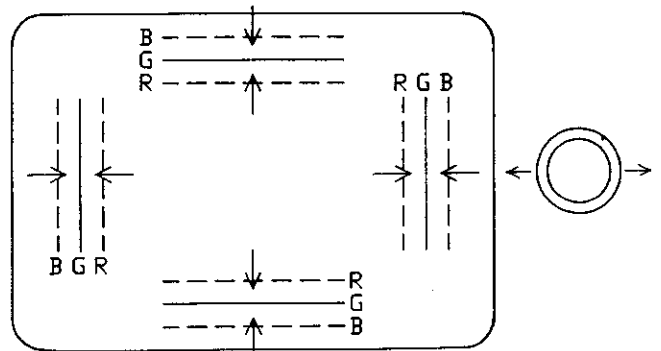

FIG 6

Section 9, Cabinet & Miscellaneous Parts List

Ref	Description	Part Number	Comment
CPT	△ 3708B22-TC COMPLETE WITH DEFLECTION YOKE	056737	14" MODELS
(1)	△ DEGAUSS COIL	577166	14" MODELS
CPT	△ A36EAM00X01 COMPLETE WITH DEFLECTION YOKE	056738	15" MODELS
(1)	△ DEGAUSS COIL	569166	15" MODELS
CPT	△ 5109B22-TC COMPLETE WITH DEFLECTION YOKE	056736	20" MODELS
(1)	△ DEGAUSS COIL	597166	20" MODELS
CPT	△ A51EBV12X01 COMPLETE WITH DEFLECTION YOKE	056735	21" MODELS (VIDEOCOLOR CRT)
OR	△ A51EAL30X01 COMPLETE WITH DEFLECTION YOKE		21" MODELS (PHILIPS CRT)
(2)	△ DEGAUSS COIL (ASSEMBLY)	589166	21" MODELS
L602	HORIZONTAL WIDTH COIL		21" VIDEOCOLOR TUBE ONLY (Fitted on deflection yoke)
(3)	△ SWITCH, MAINS 1753-504	010712	ALL MODELS
(4)	PCB, CONTROL	577195	ALL MODELS
	SWITCH, TIP (KEYBOARD)	010710	ALL MODELS
(5)	SPEAKER 4" 16 Ohm	577107	14" & 15" MODELS
(6)	SPEAKER 3 X 4" 16 Ohm	597107	20" & 21" MODELS
(7)	CABINET, FRONT	633252	14" MODELS
(7)	CABINET, FRONT	637252	15" MODELS
(8)	CABINET, FRONT	597252	20" MODELS
(8)	CABINET, FRONT	589252	21" MODELS
(9)	CABINET, BACK	577205	14" & 15" MODELS
(10)	CABINET, BACK	597205	20" & 21" MODELS
(11)	DOOR, CONTROL PANEL	577214	ALL MODELS
(12)	BUTTON, MAINS SWITCH	577261	ALL MODELS
(13)	GLASS, REMOTE WINDOW	577210	ALL MODELS
(14)	CLIP, SPEAKER FIXING		14" & 15" MODELS
(15)	CLIP, SPEAKER FIXING	597315	20" & 21" MODELS
(16)	FEET, CABINET	530228	20" & 21" MODELS
(17)	CABINET, WOODEN (CASE)	632109	20" & 21" MODELS
(18)	MASK, FRONT	597262	20" MODEL ONLY
(18)	MASK, FRONT	855252	21" MODEL ONLY
(19)	BRACKET, MAIN PCB	597316	20" & 21" MODELS
(20)	BRACKET, TELETEX PCB	885201	20" & 21" MODELS ONLY
(21)	PCB, AV	597175	
(22)	LOGO (BADGE)		
(23)	LABELS, REAR (SET)		
	AERIAL, LOOP	569901	14" & 15" PAL I MODELS
	AERIAL, ROD	577901	14" & 15" PAL B/G MODELS
	REMOTE CONTROL HANDSET	597187	MODELS WITHOUT TELETEX
	REMOTE CONTROL HANDSET	803187	MODELS WITH TELETEX
	STYROFOAM (A) TOP 1 PAIR	577805	14" & 15" MODELS
	STYROFOAM (B) BOTTOM 1 PAIR	577806	14" & 15" MODELS
	STYROFOAM (A) TOP 1 PAIR	597805	20" & 21" MODELS
	STYROFOAM (B) BOTTOM 1 PAIR	597806	20" & 21" MODELS
	CARTON BOX	577800	14" MODELS
	CARTON BOX	569800	15" MODELS
	CARTON BOX	599800	20" MODELS
	CARTON BOX	589800	21" MODELS

Teletext PCB brackets must be ordered separately when ordering cabinets for the 20" & 21" models

() Exploded view reference number.

SECTION 9 - CABINET PARTS, 14 & 15 INCH

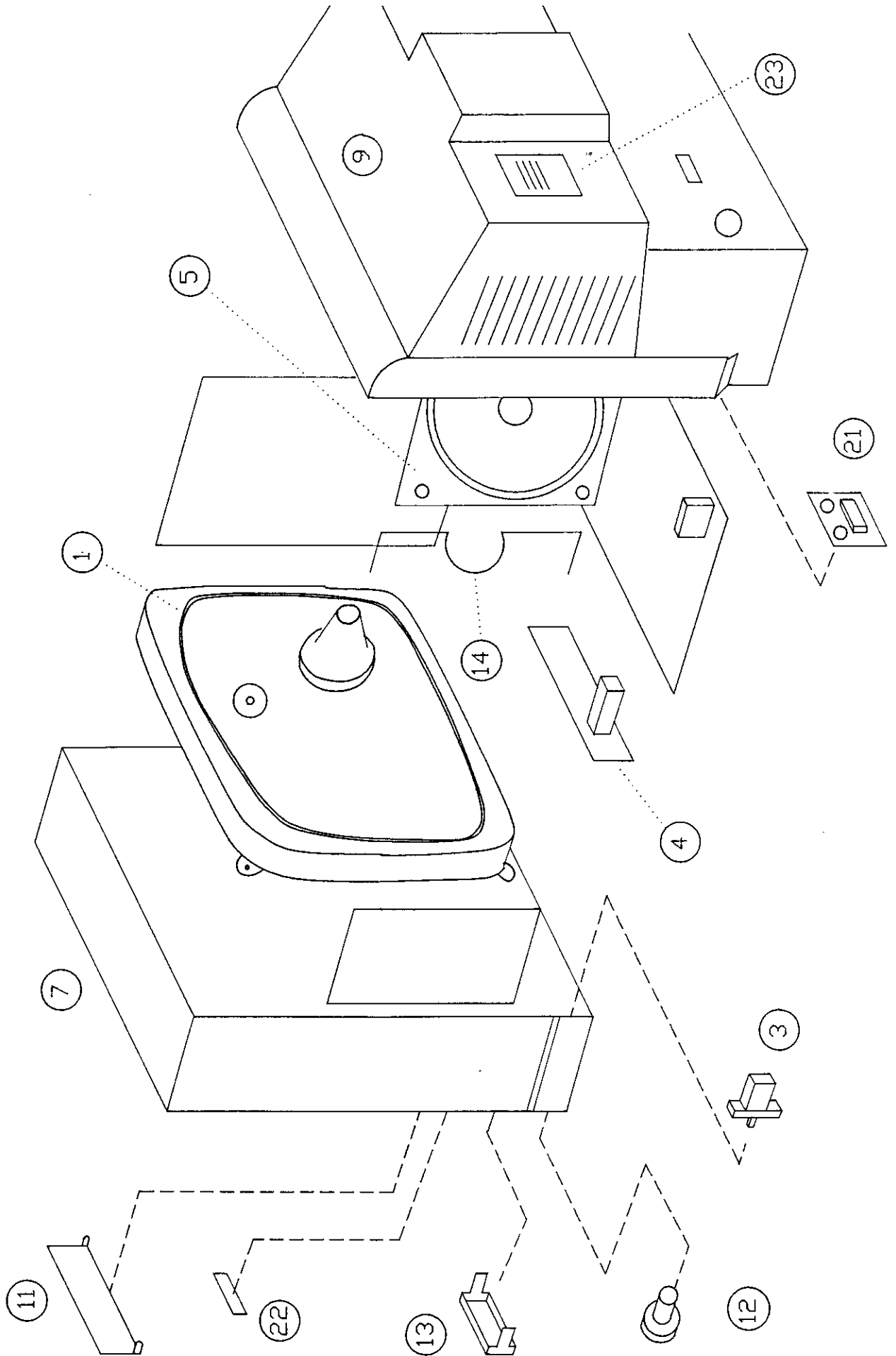

SECTION 9 - CABINET PARTS, 20 & 21 INCH

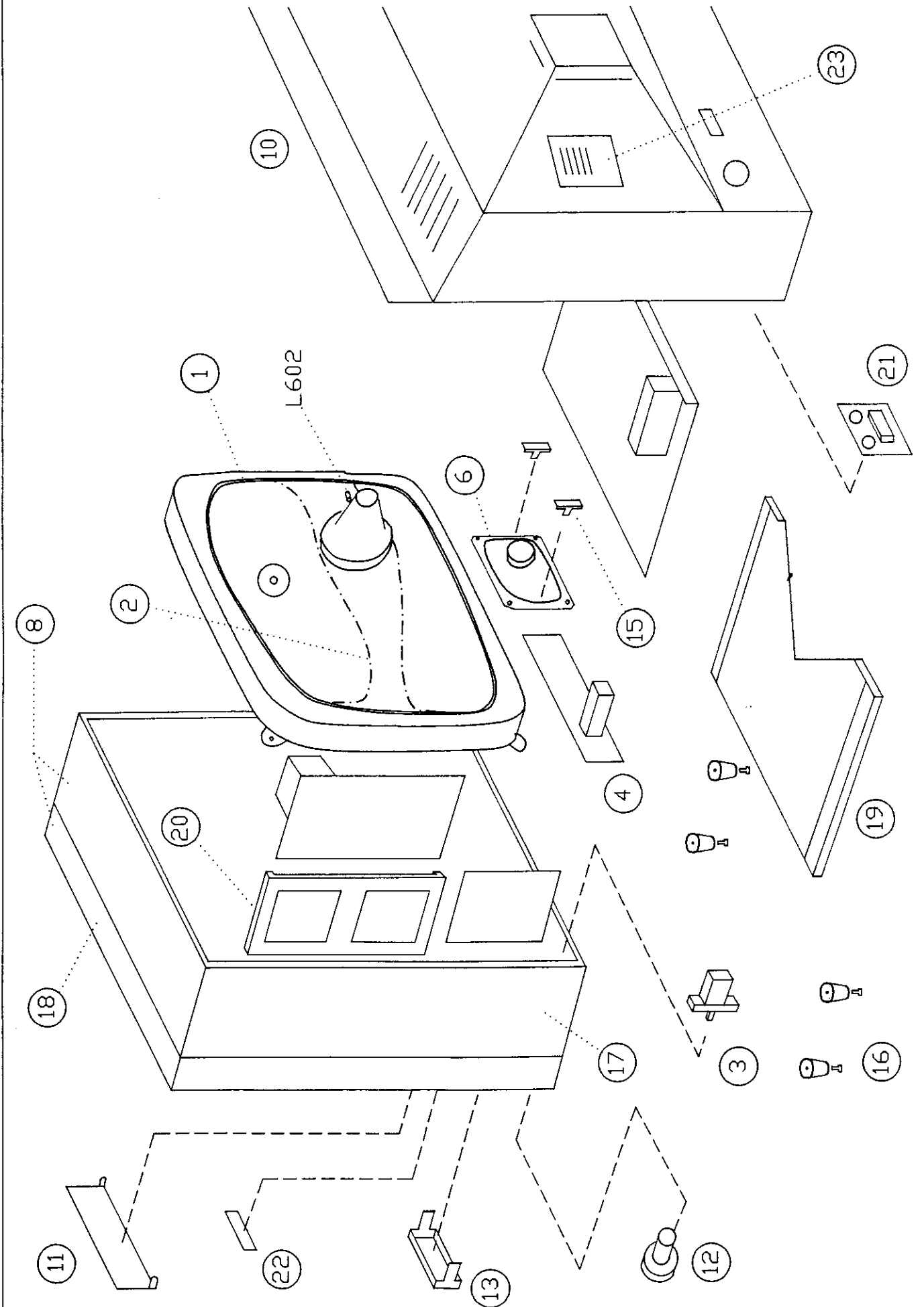

Amendment Sheet

AMD 1.1 Section 3.4 Page 1
 Line 6 Change to read Type 1604UEC or 3010UEC for UHF only
 Line 7 Delete
 Line 8 Change to read Type 1604KKC or 2000KHC for VHF/UHF
 (including cable bands).

AMD 1.2 Section 3.5 Page 1

Tuner AGC take over point. Method 1
 Replace all text with following.

Tune to a CCIR standard signal with a level of 1mV
 Connect a voltmeter to TP19
 Adjust preset potentiometer R102 (AGC) until the AGC voltage just begins to drop by 5-10mV.
 Increase the signal to 1.5mV and check that the AGC voltage is approximately 2.5V below
 its initial value.

AMD 1.3 Section 3.5 Page 4

Video detector

After 'The television VHF/UHF model, add the following:

The 2000KHC tuner does not have an injection point.

In this case remove the tuner.

If the connection between the tuner and the SAW filter is assymetrical inject a 100mV signal
 into the input of the SAW filter Z100.

If the connection is symetrical ground one input to the SAW filter and inject the signal into
 the other input.

After 'Adjust L102 for approximately 6V.' add '(6.6V if Q001 is fitted),.

AMD 1.4 Section 3.7

CHANGE R012	RESISTOR	CF	<u>220K</u>	0.25W	J	<u>104222</u>
CHANGE R013	RESISTOR	CF	<u>220K</u>	0.25W	J	<u>104222</u>
DELETE R133						
CHANGE R603	RESISTOR	MO	<u>68K</u>	<u>1.6W</u>	J	<u>133681</u>
CHANGE R809	RESISTOR	CF	<u>270K</u>	<u>0.5W</u>	J	<u>144272</u>
DELETE D100						
DELETE D101						
CHANGE C606	CAPACITOR	CER	<u>330p</u>	<u>500V</u>	M	<u>211311</u>
ADD C610	CAPACITOR	MKT	<u>100n</u>	<u>160V</u>	M	<u>214137</u>
CHANGE C822	CAPACITOR	CER	4n7	4kV		222480
CHANGE ET1	(2nd line)					<u>VDE/BS415</u>
	TUNER		1600KKC or 2000 KKC			599136

(Changes are underlined for clarity only.)

AMD 1.4 (Continued)

Insert - Circuit diagram

Change values of R012, R013, R603, C606 to those given above.

Delete R133, D100, D101

Add C610 between T601 Pin 7 and ground.

AMD 1.5 Section 4.4 Page 2

Line 34 change 'transmition' to 'transmission'.

AMD 1.6 Section 6.6

CHANGE C715 CAPACITOR TANT 1u0 25v M 239131

(Change is underlined for clarity only.)

AMD 1.7 Section 7.1 and 7.7 Page 1

Section 7.7 Teletext System Parts List.

CHANGE R902 RESISTOR CF 180R 0.25W J 101106

(Change is underlined for clarity only.)

Section 7.1 Teletext System Circuit Diagram

Change value of R902 as above.

AMD 1.8 Section 9 Page 1

ADD MAINS CORD WITHOUT PLUG

033129 UK

ADD MAINS CORD WITH STANDARDT PLUG

599500 EURO NON-FTZ

ADD MAINS CORD WITH FILTERED PLUG

54C500 EURO FTZ

AMD 1.9 Insert Component overlay

Control board

Delete words 14'' and 15''

END

ITY OF
GE IS
T THAT
ABLE

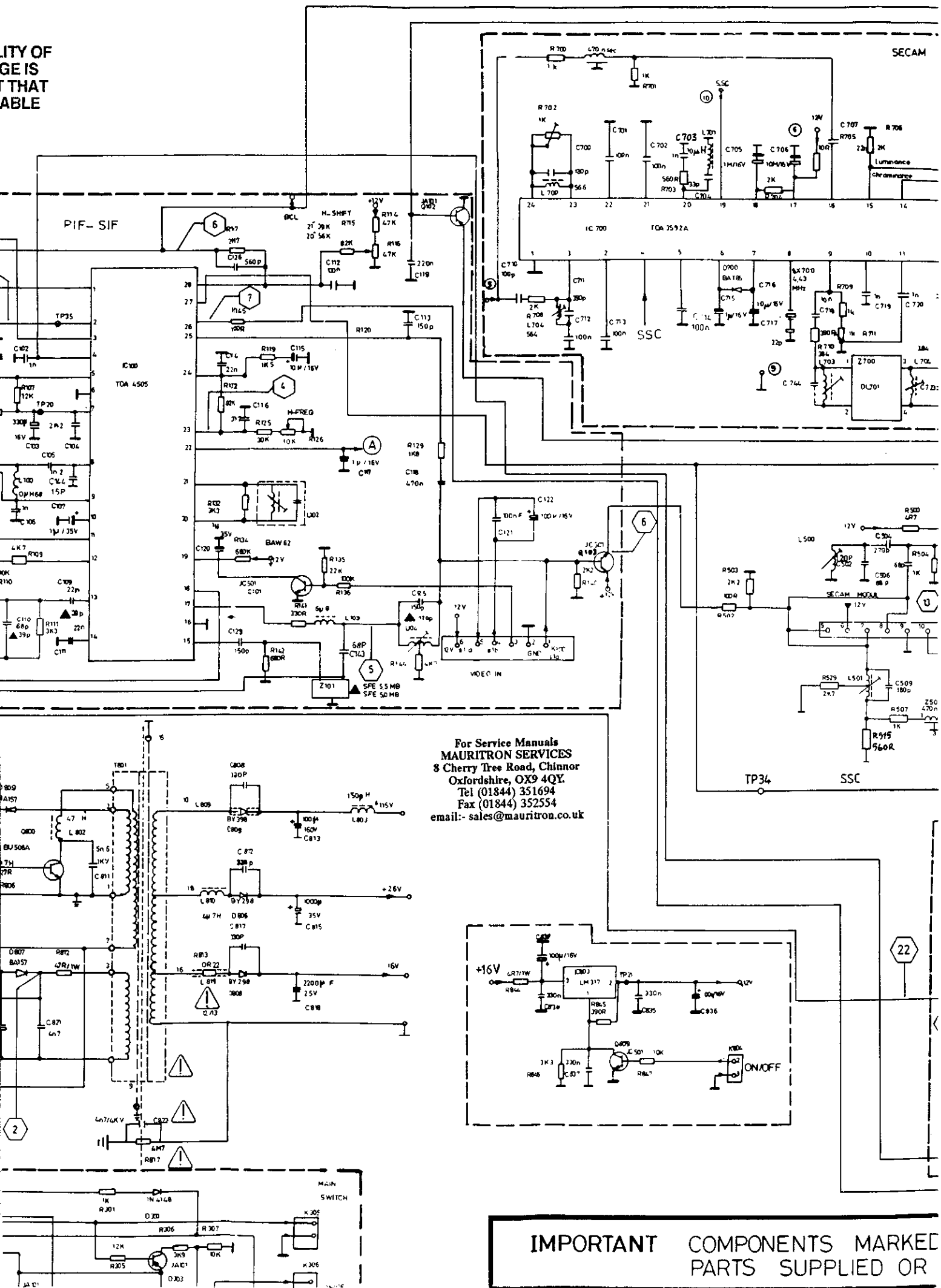

**IMPORTANT COMPONENTS MARKED
PARTS SUPPLIED OR**

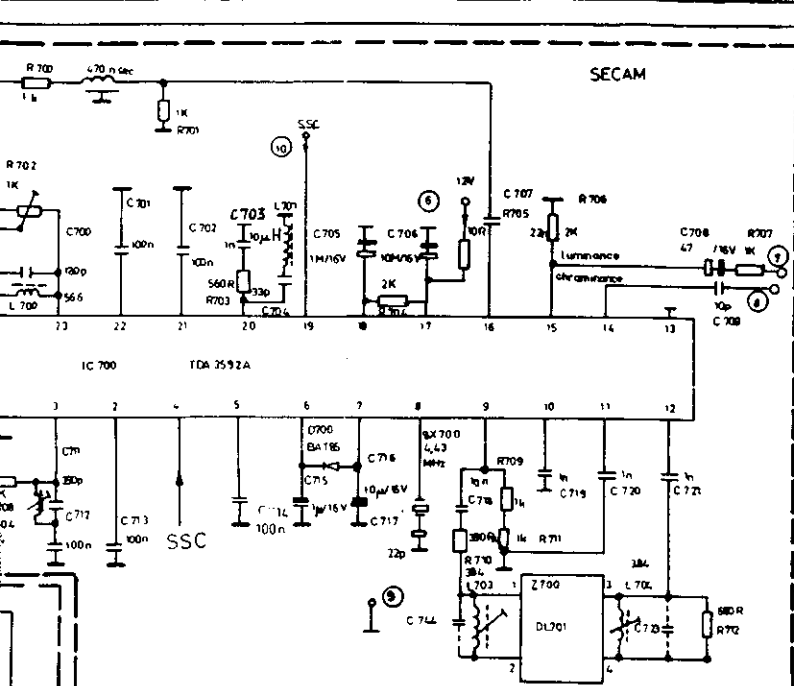

	PAL I	PAL BG
Z 100	SY 153 UMF	SY 177 UMF/VMF
Z 101	SFE 60 MB	SFE 55 MB
C 125	120PJ	150PJ
C 110	39 PK	68 PK
ET 1	150L UEC	100K KKL

	L601	C601
21"	AT4042 /90	330NF 250V
21"	AT4042 /90	330NK 250V
20"	AT4042 /90	470NK 250V
15"	AT4042 /90	330NK 250V
14"	AT4042 /90	470NF 250V

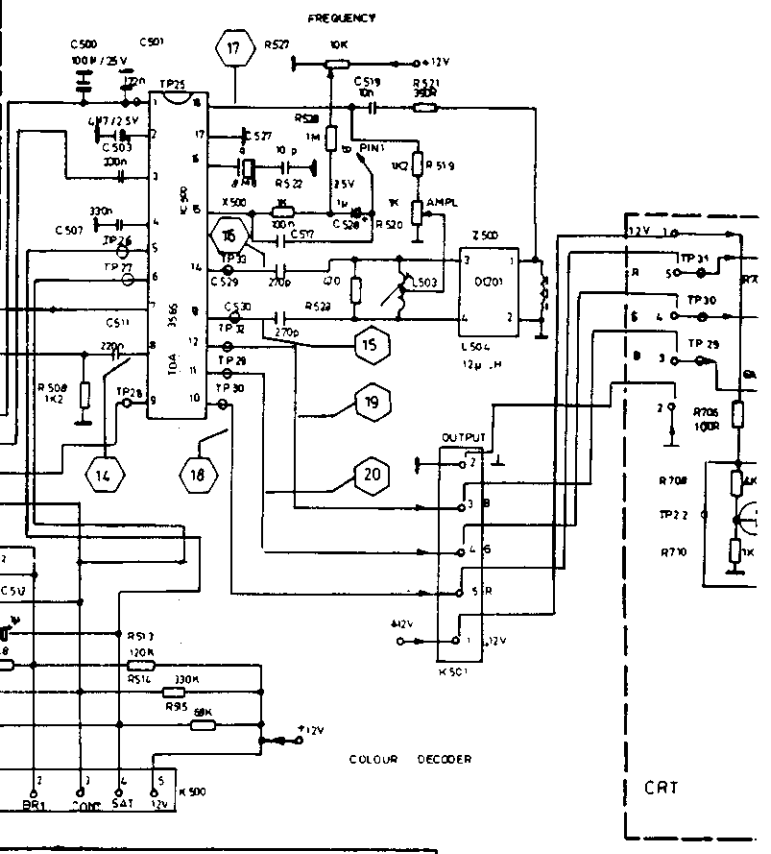
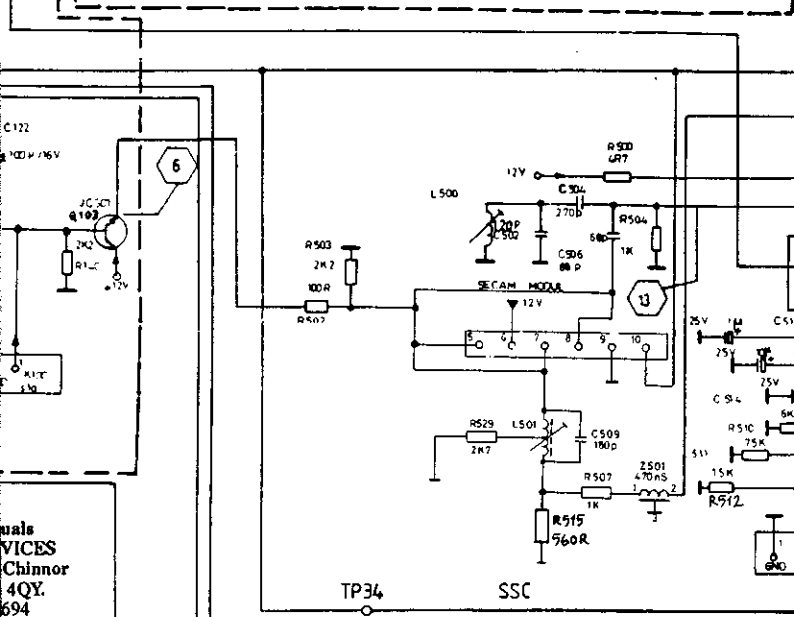

anal
VICES
Chinnor
4QY.
694
554
ron.co.uk

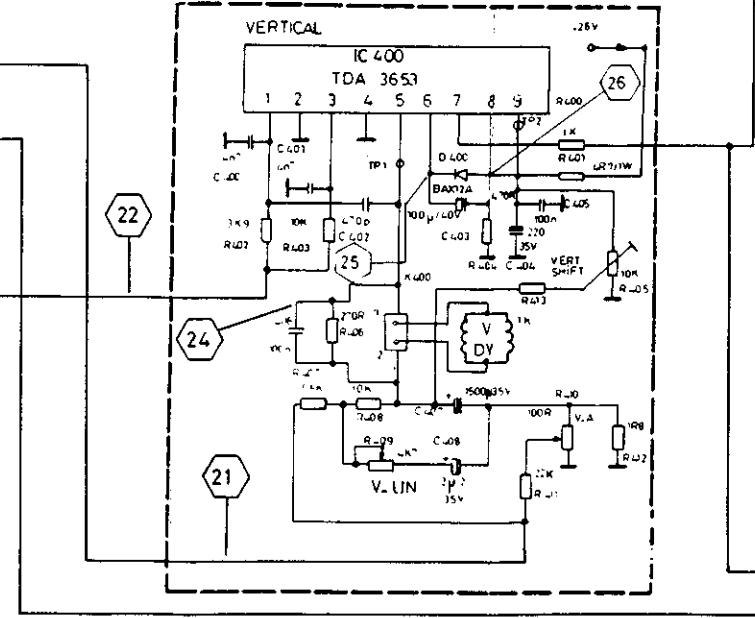
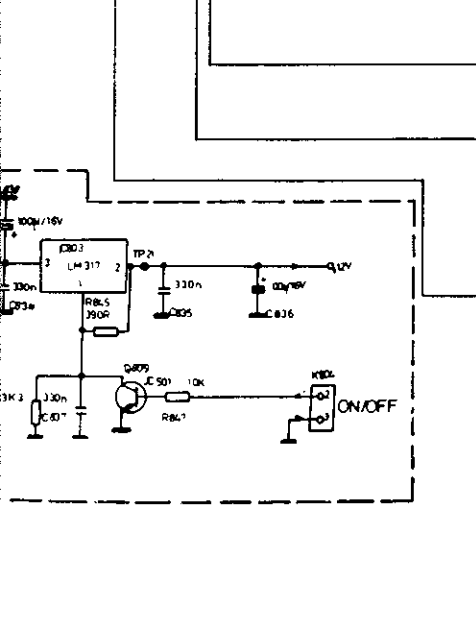

THE QUALITY OF
THIS PAGE IS
THE BEST THAT
IS AVAILABLE

IMPORTANT COMPONENTS MARKED WITH SYMBOL ARE CRITICAL FOR SAFETY PARTS SUPPLIED OR APPROVED BY THE MANUFACTURER

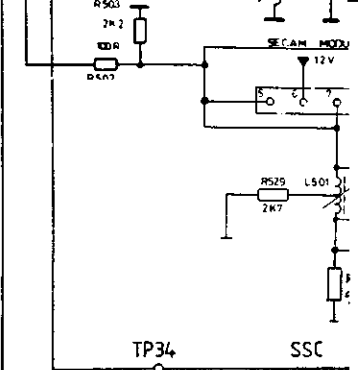
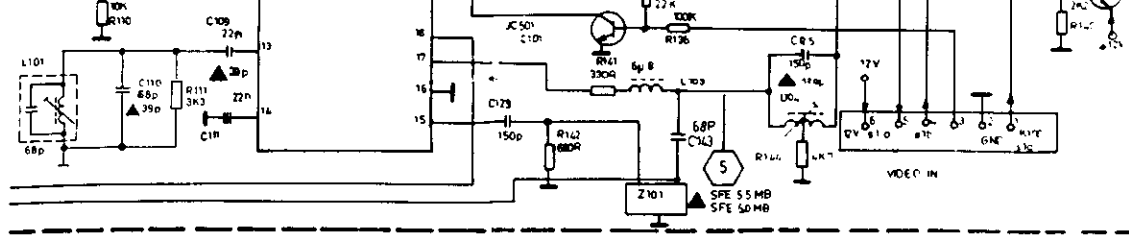

For Service Manuals
MAURITRON SERVICES
 8 Cherry Tree Road, Chinnor
 Oxfordshire, OX9 4QY.
 Tel (01844) 351694
 Fax (01844) 352554
 email:- sales@mauritron.co.uk

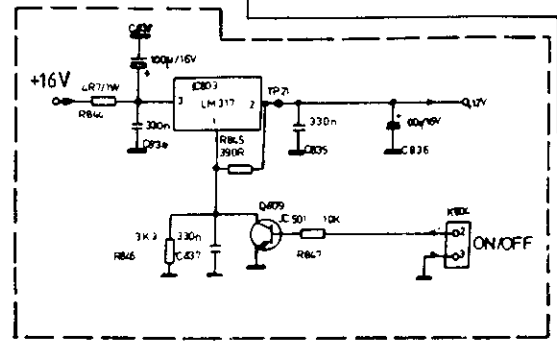
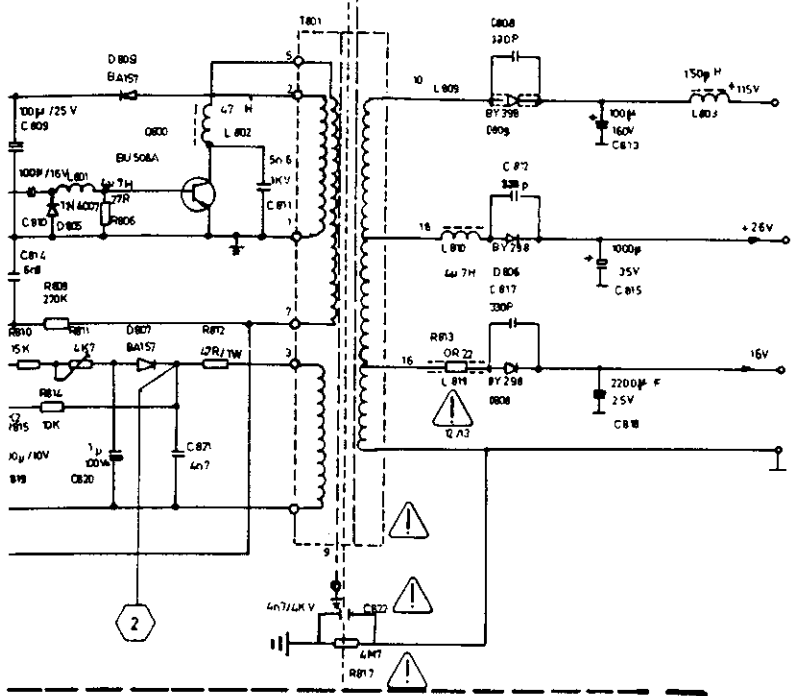

For Service Manuals
MAURITRON SERVICES
 Cherry Tree Road, Chinnor
 Oxfordshire, OX9 4QY.
 Tel (01844) 351694
 Fax (01844) 352554
 ail:- sales@mauritron.co.uk

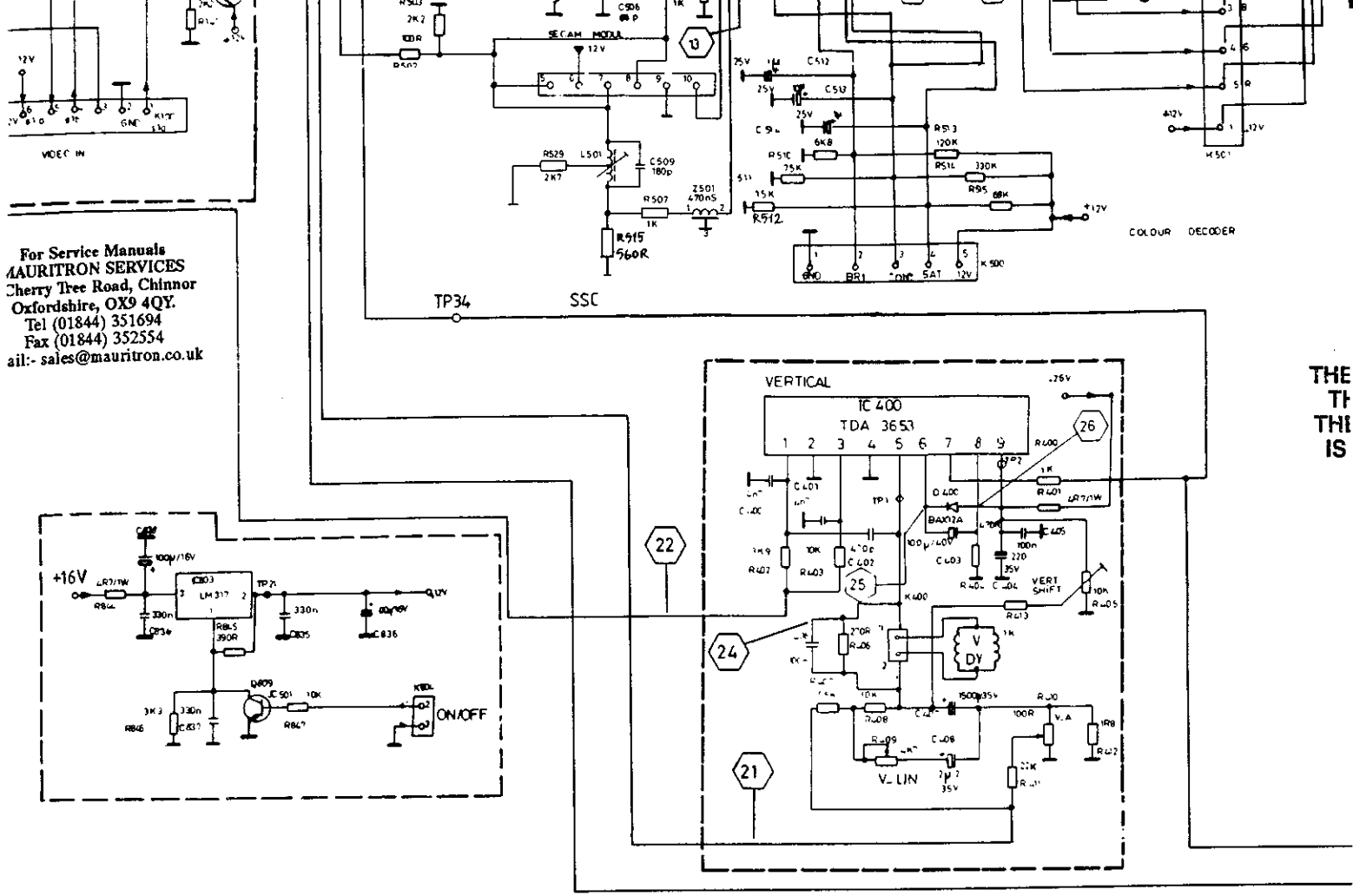

IMPORTANT COMPONENTS MARKED WITH SYMBOL ARE CRITICAL FOR PARTS SUPPLIED OR APPROVED BY THE MANUFACTURER

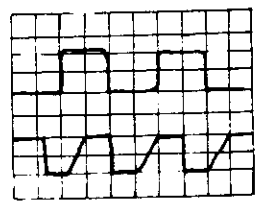

1 10 V PP

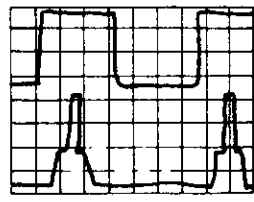

7 0.7 V PP



13 0.6 V PP

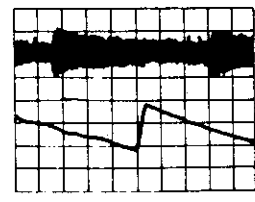

2 4.0 V PP

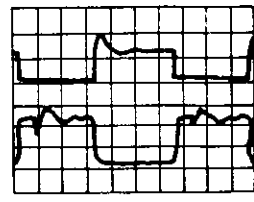

8 8 V PP

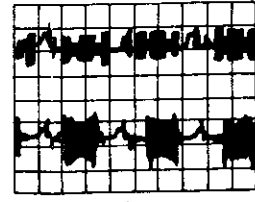

14 0.5 V PP

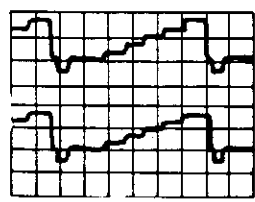

3 12 V PP

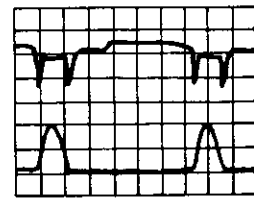

9 30 V PP

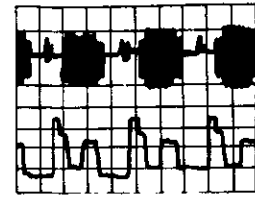

15 0.15 V PP



4 2 V PP



10 0.5 V PP



16 0.7 V PP

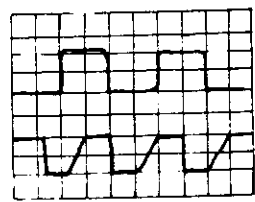

5 2.4 V PP

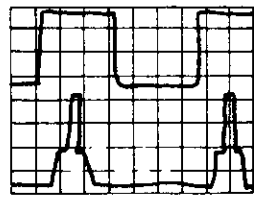

11 5.2 V PP



17 1 V PP



6 2.4 V PP

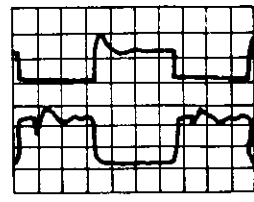

12 0.8 V PP

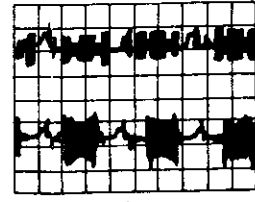

18 4.8 V PP

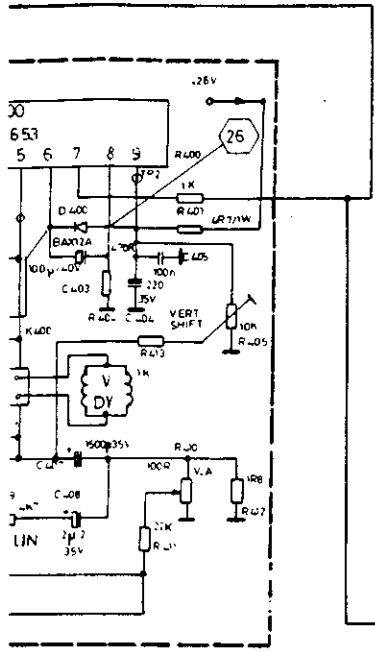
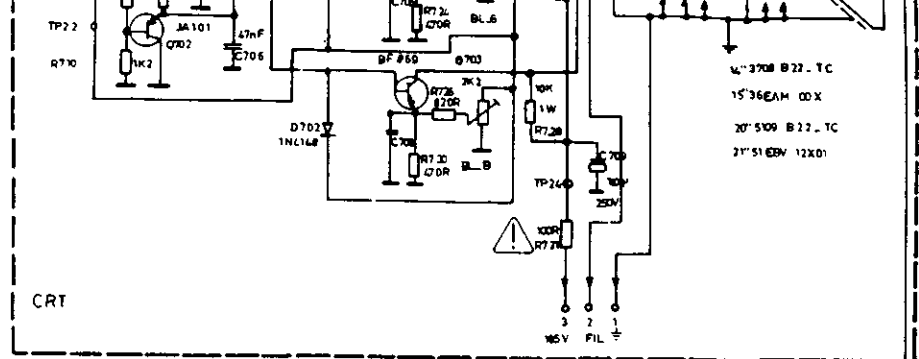
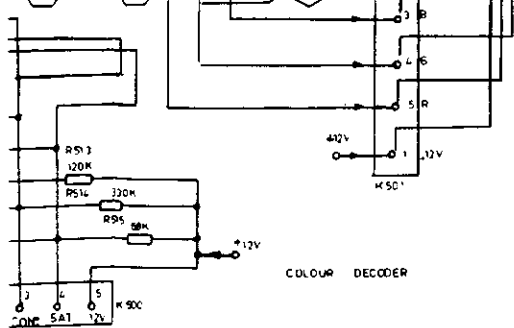

THE QUALITY OF THIS PAGE IS THE BEST THAT IS AVAILABLE

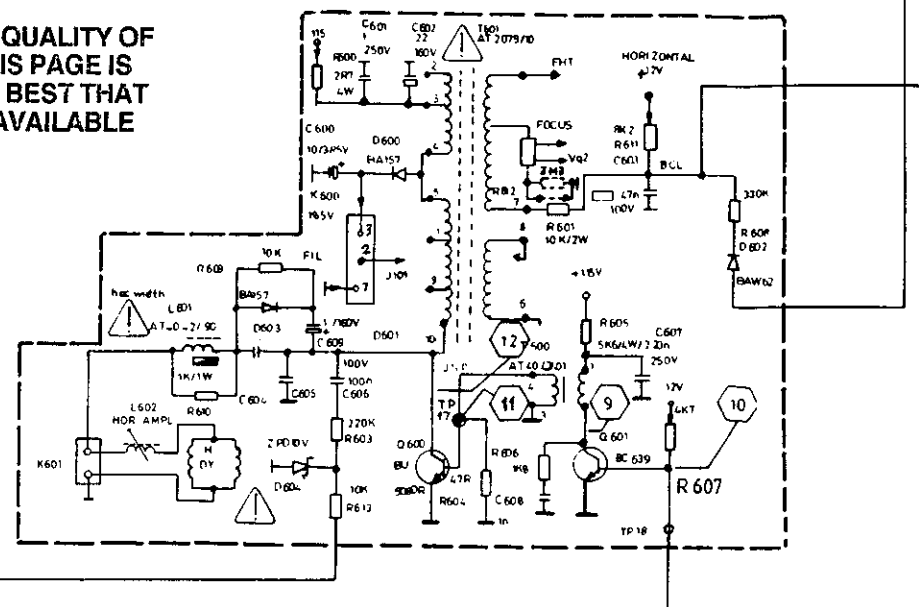

⚠ ARE CRITICAL FOR SAFETY AND MUST ONLY BE REPLACED BY THE MANUFACTURER

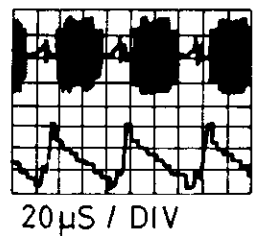

13 0.6 V PP

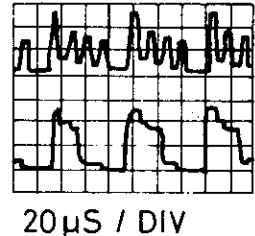

19 4.8 V PP

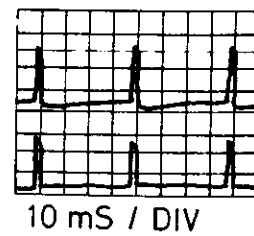

25 22 V PP

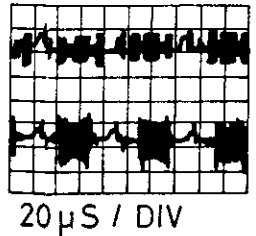

14 0.5 V PP

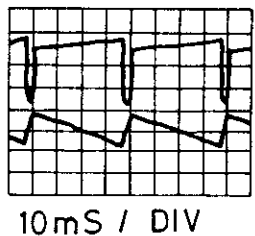

20 4.5 V PP

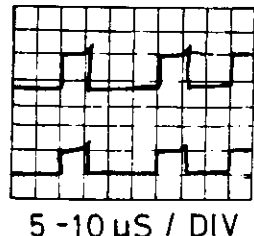

26 2 V PP

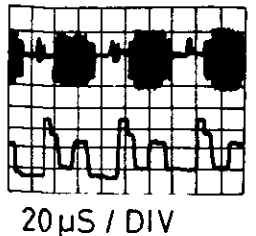

15 0.15 V PP

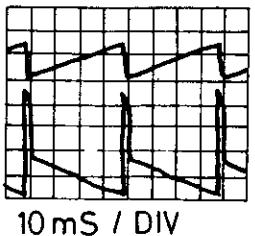

21 2.5 V PP

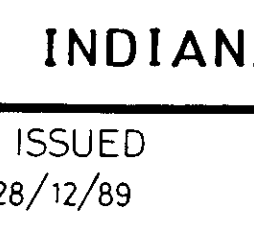

27 1.1 V PP



16 0.2 V PP



22 1.4 V PP



28 2.6 V PP

INDIANA
ISSUED
28/12/89

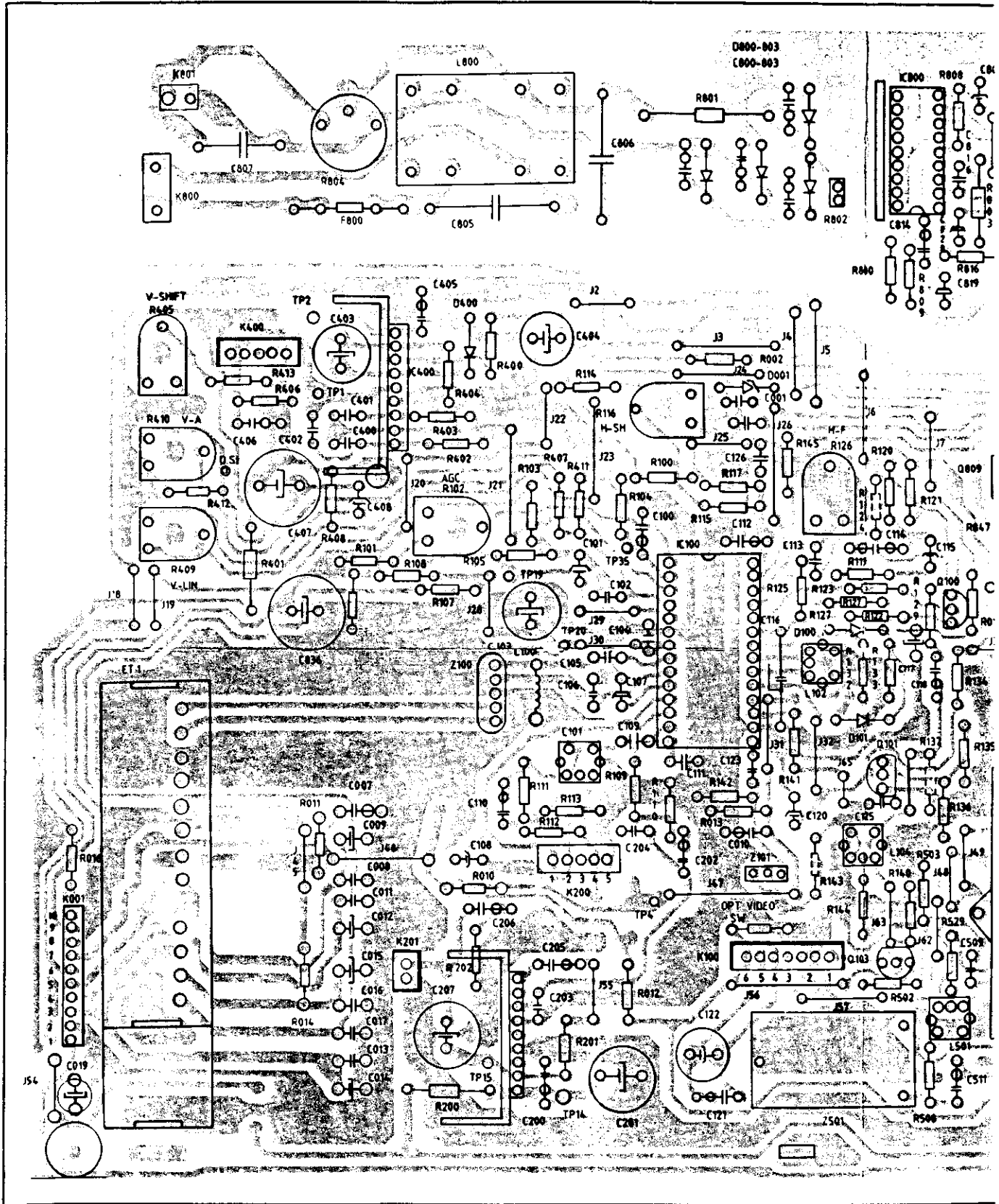

MAIN CHASS

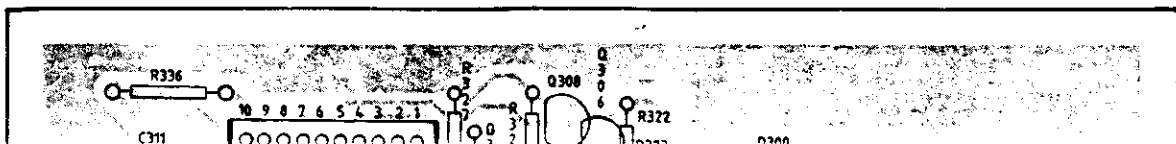

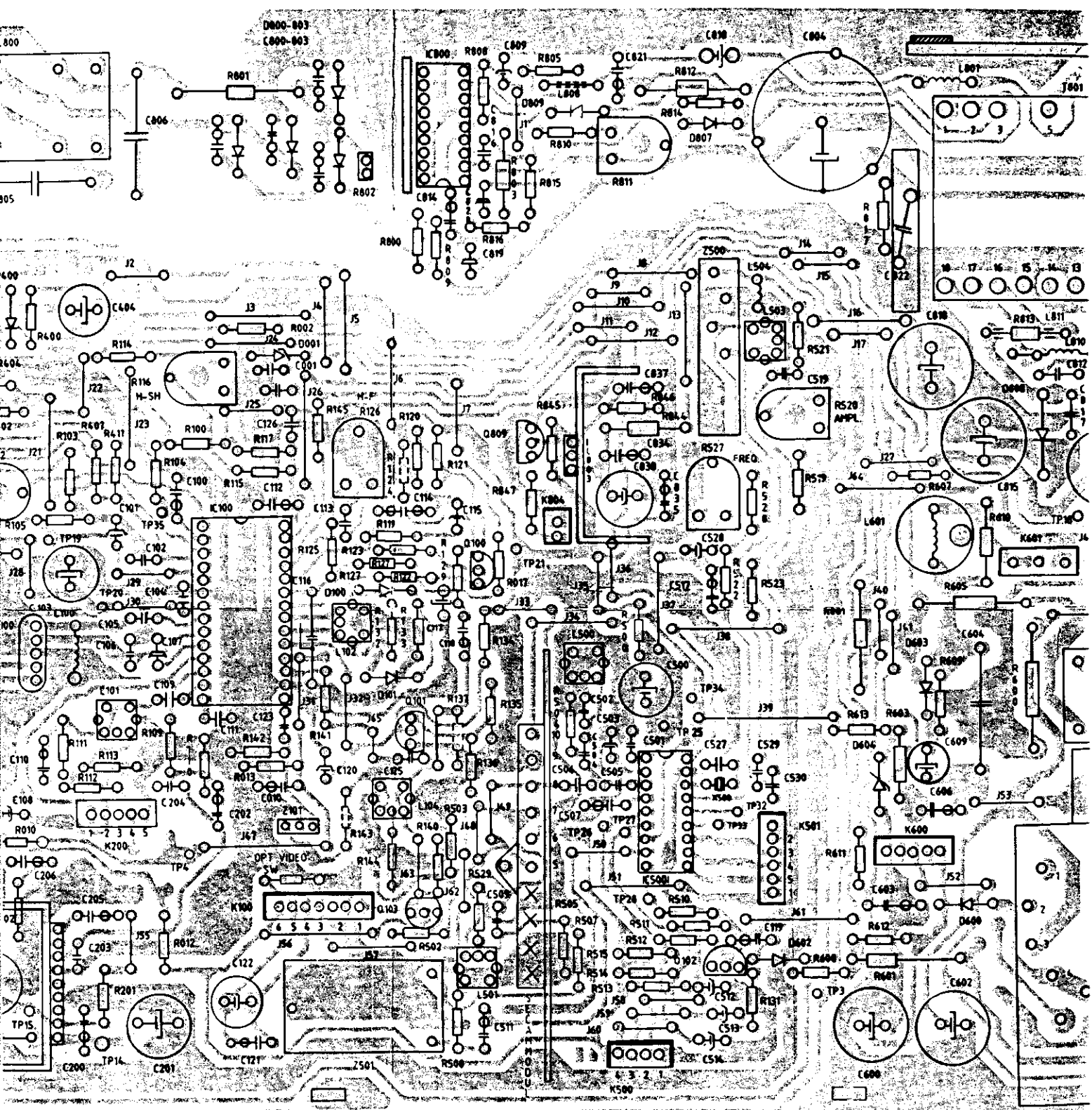

MAIN CHASSIS

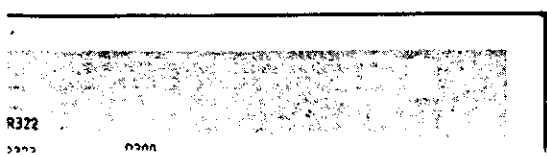

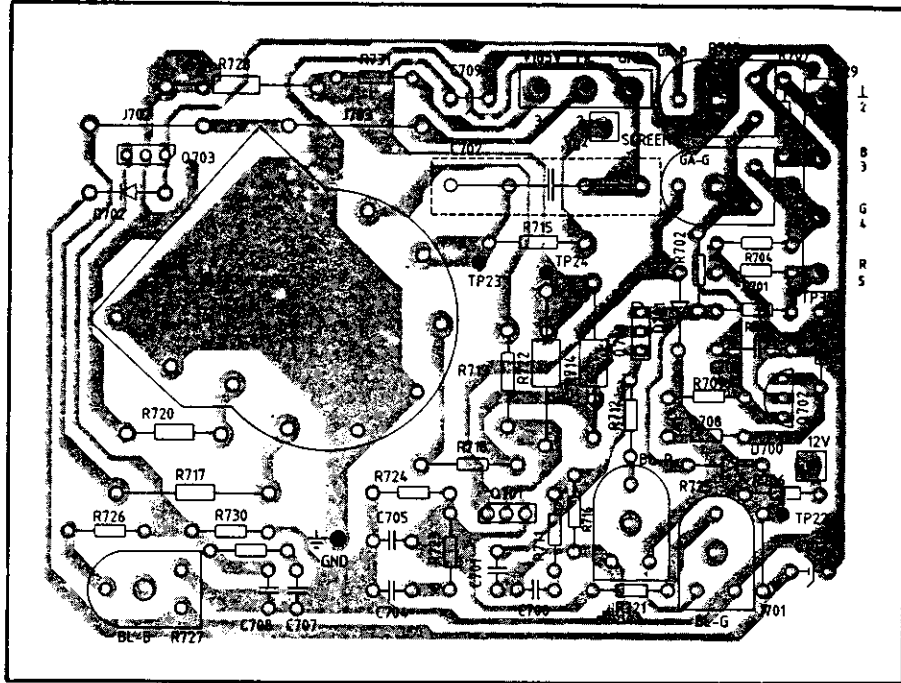

MINI NECK 15''

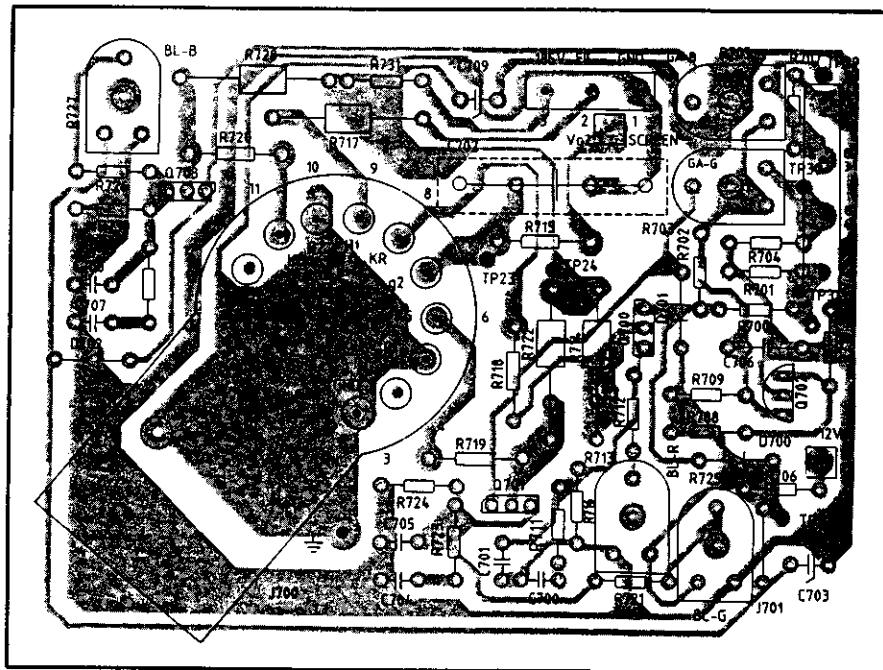

NARROW NECK CRT

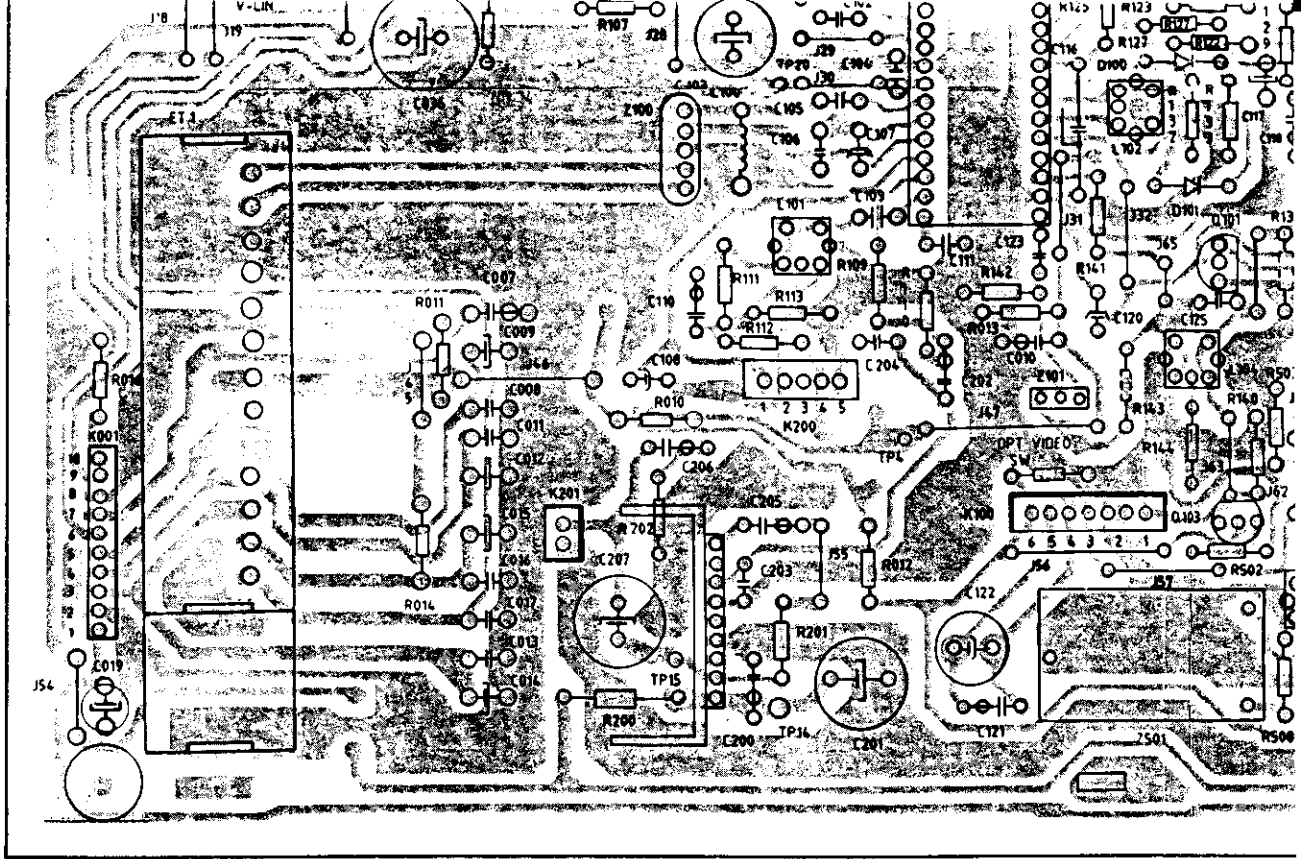

MAIN CH

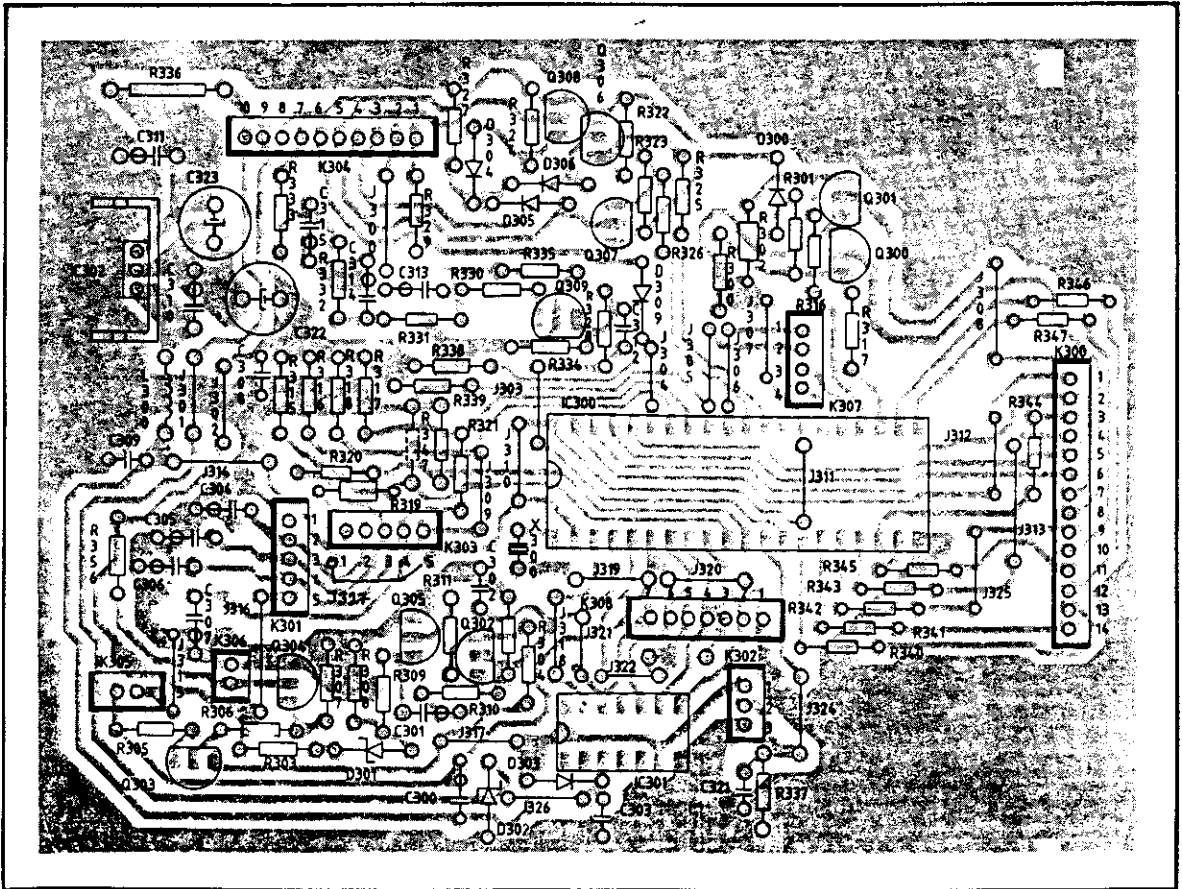

REMOTE BOARD

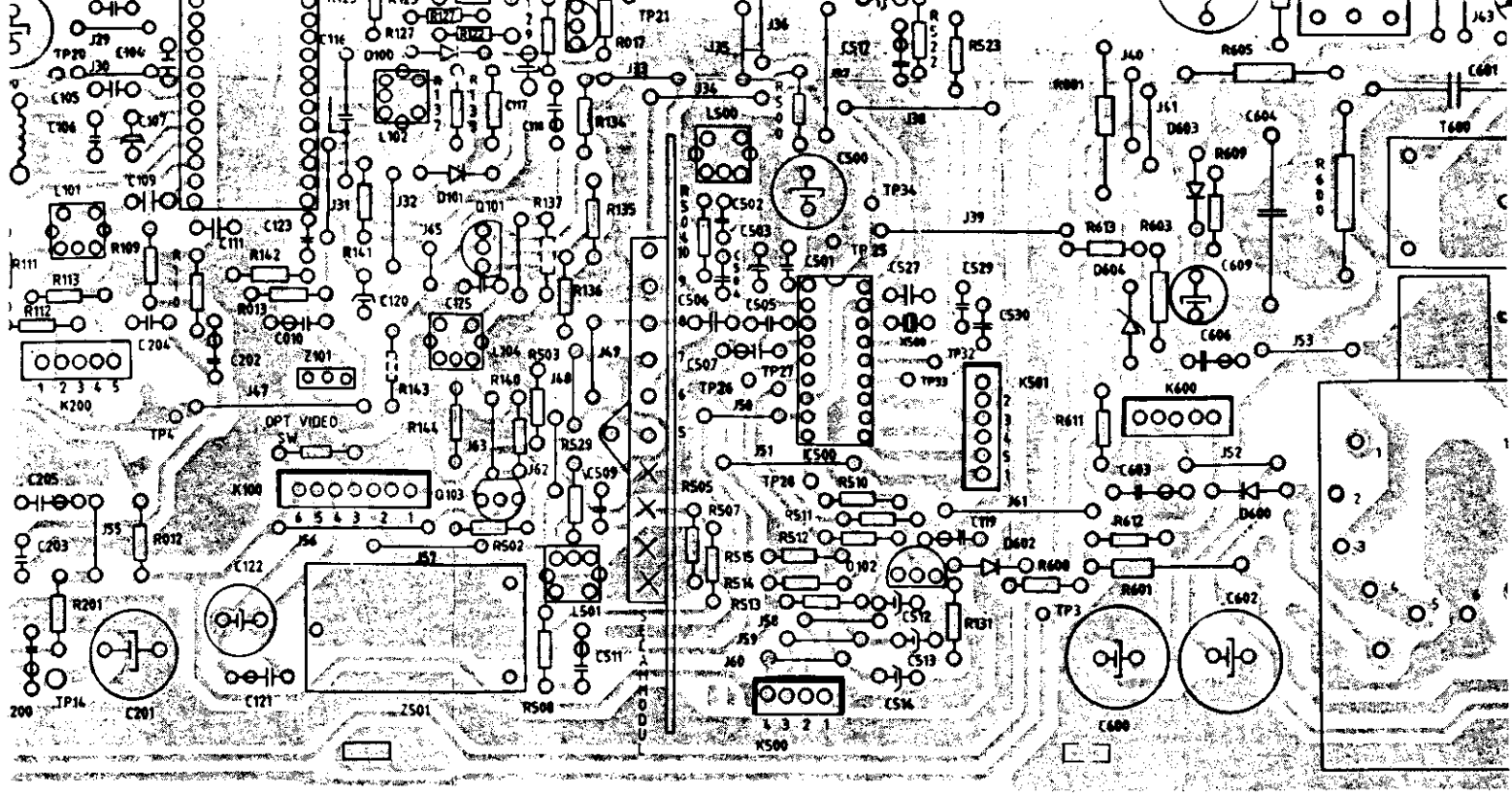

MAIN CHASSIS

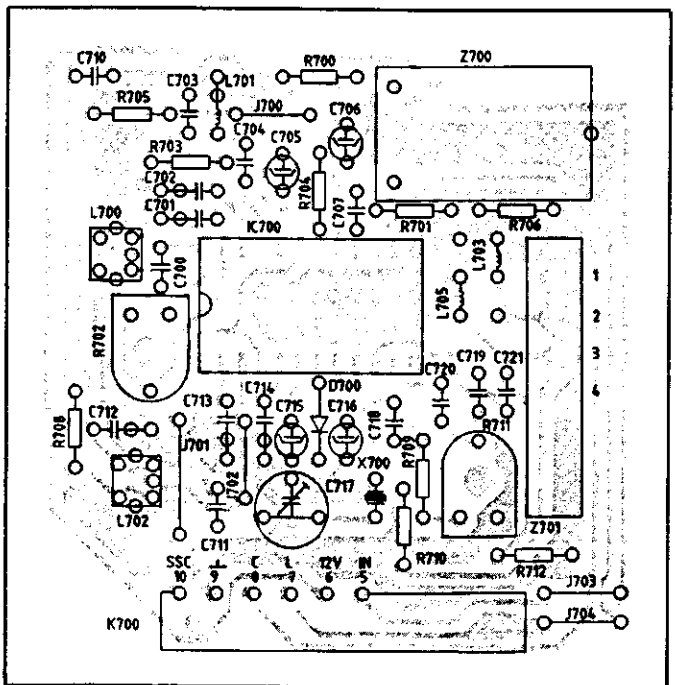
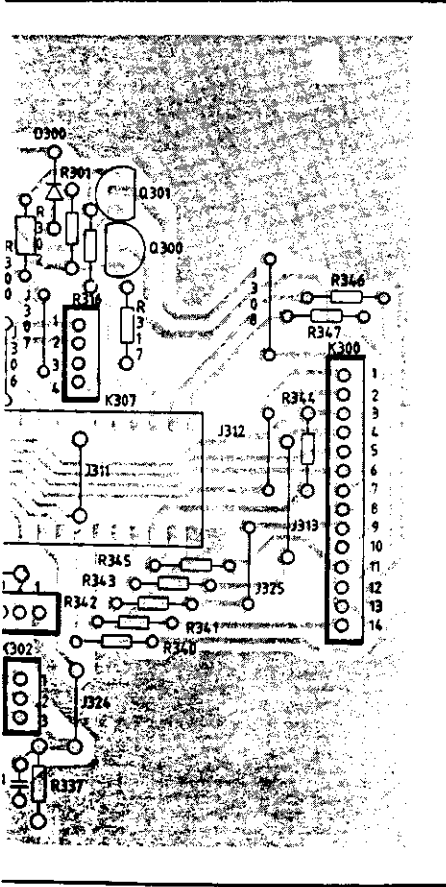

SECAM TRANSCODER

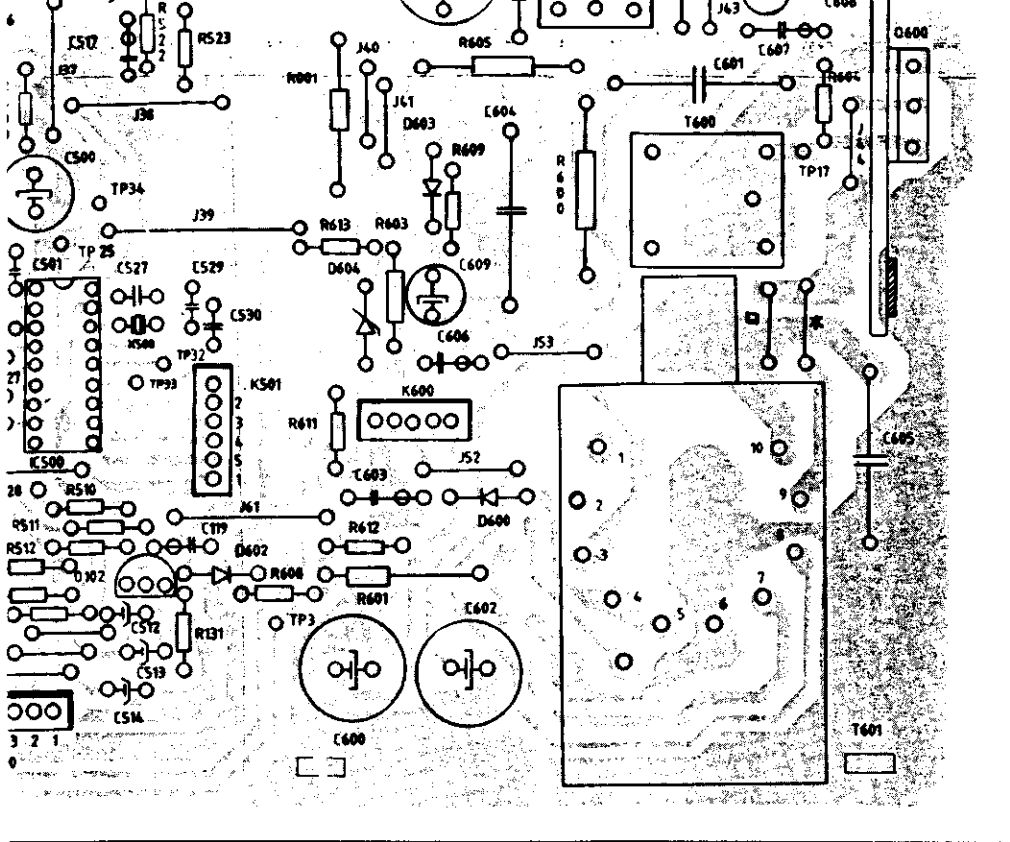

For Service Manuals
MAURITRON SERVICES
 8 Cherry Tree Road, Chinnor
 Oxfordshire, OX9 4QY.
 Tel (01844) 351694
 Fax (01844) 352554
 email:- sales@mauritron.co.uk

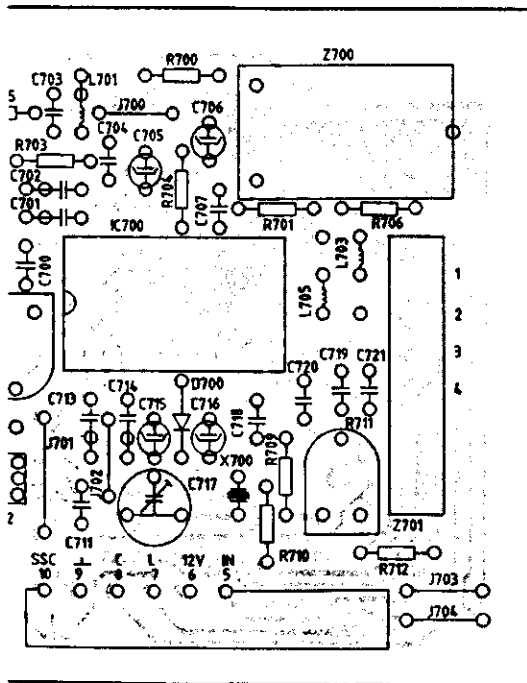

SECAM TRANSCODER

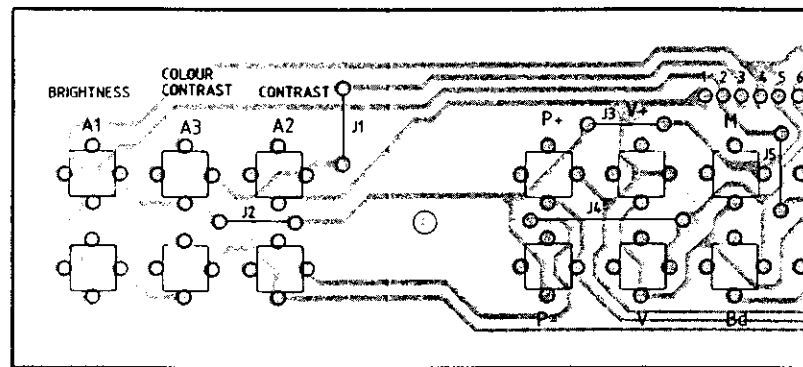

CONTROL BO

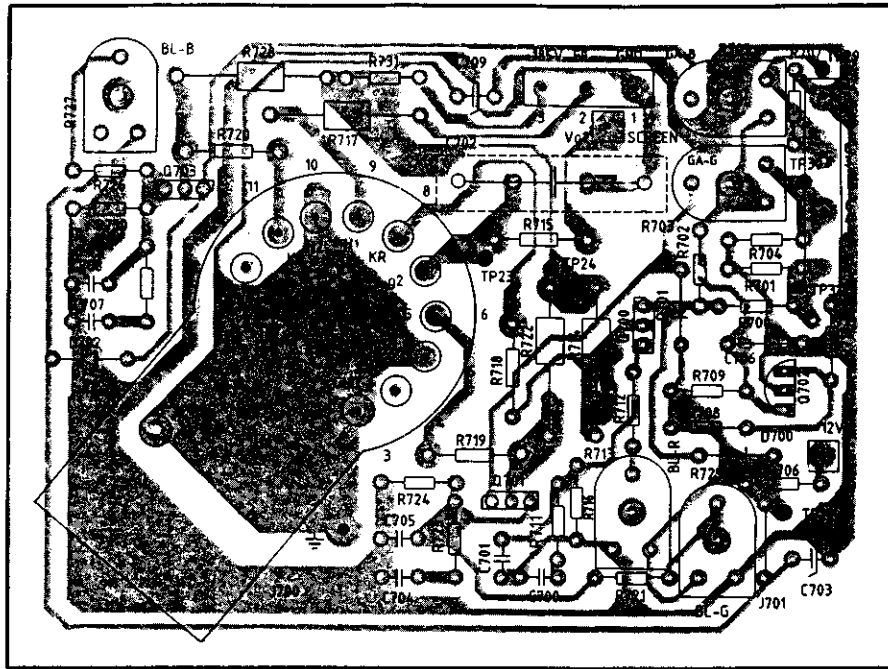

NARROW NECK CRT

For Service Manuals
MAURITRON SERVICES
 8 Cherry Tree Road, Chinnor
 Oxfordshire, OX9 4QY.
 Tel (01844) 351694
 Fax (01844) 352554
 email:- sales@mauritron.co.uk

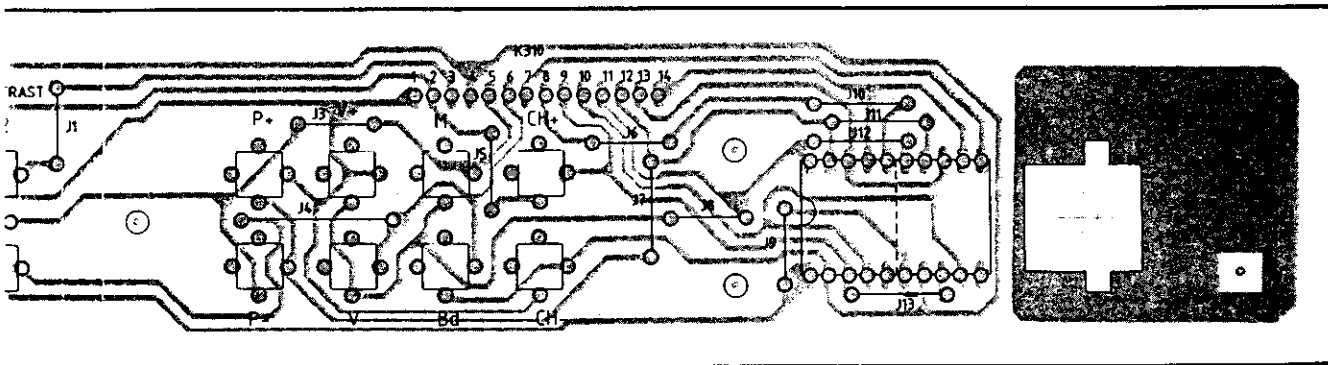

CONTROL BOARD 14'' + 15''

**INDIANA
 COMPONENT OVERLAY**