

MATSUI 1436
COLOUR TELEVISION
SERVICE MANUAL

Specifications are subject to change without notice.

MATSUI 1436

COLOUR TELEVISION

CONTENTS

SPECIFICATIONS	1
IMPORTANT SERVICE SAFETY INFORMATION	2
CHASSIS REMOVAL	3
INSTALLATION AND SERVICE INSTRUCTIONS	4-6
STATIC CONVERGENCE ADJUSTMENT	7
CONVERGENCE ADJUSTMENT	8
GENERAL ALIGNMENT INSTRUCTIONS	9
VIDEO IF & AFC SWEEP ALIGNMENT	10
P.C.B. LAYOUTS (LED/RIV / CONTROL PBC / POWER SWITCH / CRT SWITCH)	11
CHASSIS WAVEFORMS	12-13
P.C.B. LAYOUT	15
SCHEMATIC DIAGRAM	16
BLOCK DIAGRAM	17
IC BLOCK DIAGRAM/VOLTAGE CHARTS	19
WIRING DIAGRAM	20
EXPLODED VIEW	21
REPLACEMENT PARTS LIST	23-27

MATSUI 1436COLOUR TELEVISIONSPECIFICATIONS

SYSTEM :	PAL 1
PICTURE TUBE :	14 inch Picture Tube
TUNING RANGE :	UHF 21 - 69ch
PRESET :	44 ch
ANTENNA JACK :	75 ohm DIN Type
SPEAKER :	Dynamic 77mm round
SPK-IMPEDANCE :	8 ohm 1 Watt
AUDIO POWER OUTPUT :	1W RMS (THD 10%)
TERMINALS :	VIDEO INPUT/OUTPUT 1Vp-P/75 OHMS AUDIO INPUT/OUTPUT 300my
POWER SUPPLY :	AC200~240V, 50Hz
POWER CONSUMPTION :	50W
DIMENSIONS :	365(W)x340(H)x370(D)mm
WEIGHT :	10.5kg

MATSUI 1436

COLOUR TELEVISION

IMPORTANT SERVICE SAFETY INFORMATION

Operation of receiver outside of cabinet or with back removed involves a shock hazard. Work on these models should only be performed by those who are thoroughly familiar with precautions necessary when working on high voltage equipment.

Exercise care when servicing this chassis with power applied. Many B pulsed and high voltage RF terminals are exposed which, if carelessly contacted, can cause serious shock or result in damage to the chassis. Maintain interconnecting ground lead connections between chassis, escutcheon, picture tube dag, tuner and cassette recorder cluster when operating chassis.

Certain HV failures can increase X-ray radiation. Receivers should not be operated with HV levels exceeding the specified rating for their chassis type. The maximum operating HV specified for the chassis used in these receivers is 22kV ± 0.5 kV at normal condition with a line voltage of 240V AC. Higher voltage may also increase possibility of failure in HV supply.

It is important to maintain specified values of all components in the horizontal and high voltage circuits and anywhere else in the receiver that could cause a rise in high voltage or operating supply voltages. No changes should be made to the original design of the receiver.

Components shown in the shaded areas on the schematic diagram and/or identified by Δ in the replacement parts list should be replaced only with exact Factory recommended replacement parts. The use of unauthorized substitute parts may create a shock, fire, X-radiation, or other hazard. To determine the presence of high voltage, use an accurate, high impedance, HV meter connected between second anode lead and the CRT dag grounding device. When servicing the High Voltage System, remove static charge from it by connecting 10K ohm resistor in series with an insulated wire (such as a test probe) between picture tube dag and 2nd anode lead (AC line cord disconnected from AC supply).

The picture tube used in this receiver employs integral implosion protection. Replace with tube of the same type number for continued safety. Do not lift picture tube by the neck. Handle the picture tube only when wearing shatter-proof goggles and after discharging the high voltage completely. Keep others without shatter-proof goggles away.

When removing springs or spring mounting parts from tuner, tuner cluster or chassis, shatter-proof goggles must be worn. Keep others without shatter-proof goggles away.

SAFETY INSPECTION

Before returning the receiver to the user, perform the following safety checks:

PROTECT YOUR CUSTOMER

1. Inspect all lead dress to make certain that leads are not pinched or that hardware is not lodged between the chassis and other metal parts in the receiver.
2. Replace all protective devices such as non-metallic control knobs, insulating fishpapers, cabinet backs, adjustment and compartment covers or shields, isolation resistor-capacity networks, mechanical insulators, etc.
3. To be sure that no shock hazard exists, a check for the presence of leakage current should be made at each exposed metal part having a return path to the chassis (antenna, cabinet metal, screw heads, knobs and/or shafts, escutcheon, etc.) in the following manner.

Plug the AC line cord directly into a 240V AC receptacle. (Do not use an isolation Transformer during these checks.) All checks must be repeated with the AC line cord plug connections reversed. (If necessary, a non-polarized adapter plug must be used only for the purpose of completing these checks.)

When exchange IC102 (EAROM), set UHF band the order of below procedure.

1. After exchanged IC102, fix the terminals to TP B and TP C on Control P.C. board by lead wire or other things.
2. Push and keep "CH SET" button.
3. Repeat shorting TP B and TP C on Control P.C. board to indicate band mark "U".
4. Push tune up or tune down button 2 or 3 sec.
5. Release "CH SET" button.

If available, measure current using an accurate leakage current tester. (Use Standard Equipment Item No. 25086, 21641.) Any reading of 0.2 mA or more is excessive and indicates a potential shock hazard which must be corrected before returning the receiver to the owner.

If a reliable leakage current tester is not available, this alternate method of measurement should be used. Using two clip leads, connect a 2000 ohm, 10 watt resistor paralleled by a 0.15 MF capacitor, in series with a known earth ground, such as a water pipe or conduit and the metal part to be checked. Use a VTVM or VOM with 1000 ohms per volt, or higher, sensitivity to measure this AC voltage drop across the resistor. Any reading of 0.35 volt RMS or more is excessive and indicates a potential shock hazard which must be corrected before returning the receiver to the owner.

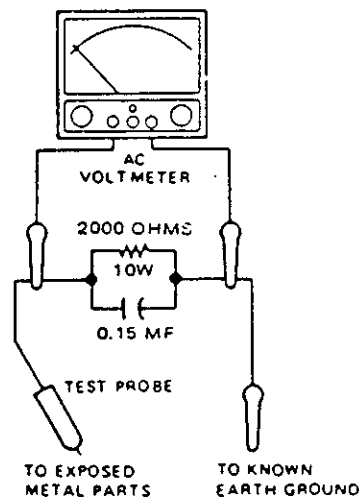

**X-RAY PROTECTOR CIRCUIT CHECK
PERFORM WHENEVER HIGH VOLTAGE CIRCUITRY OR POWER
SUPPLY CIRCUITRY IS SERVICED.**

1. Plug the AC Line Cord (P1) into a 240V AC 50Hz receptacle.
2. Turn the Power Switch (S650) on and wait for about 10 minutes.
3. Connect the antenna leads to the Antenna Terminal (P2) and select a broadcasting station.
4. Connect DC Digital Voltmeter to TP17 (positive lead) and TP18 (negative lead).
5. Increase the voltage between TP17 and TP18 by connect the 10k ohm resistor to TP15 and TP16 and confirm that X-Ray Protector Circuit functions when the DC Digital Voltmeter reads 142.5V ± 2.5V.
6. If picture and sound do not disappear check IC301, D485, D602, C493, C492, R492, R499 and R498.

MATSUI 1436

COLOUR TELEVISION

CHASSIS REMOVAL

1. Remove 4 screws (195) from cabinet back.
2. Remove 1 screw (198) from A/V Jack.
3. Remove 1 screw (196) from FBT.
4. Remove 1 screws (195) from AC CORD.HOLD (160).
5. Disconnect Plug (308) from tuner (TU101).
6. Disconnect CRT socket P.C. board from CRT (301).
7. Disconnect anode lead at picture tube to chassis ground through a 10 k ohm resistor.
8. Disconnect anode lead from picture tube.
9. Disconnect connectors LCN650, LCN701, LCN851 from main P.C. board.
10. When replacing chassis, reverse the above procedure making certain that all connectors and leads are fastened in their original places.

CRT REMOVAL

CAUTION: Wear shatter-proof goggles and exercise proper handling precautions when working around high vacuum picture tubes.

1. Remove chassis per instructions under CHASSIS REMOVAL.
2. Remove convergence magnet assembly (303) from neck of CRT.
3. Remove deflection yoke (302) from neck of CRT.
4. Remove 3 wedges (164) from CRT.
5. Remove 1 spring and braid wire (188) from CRT P.C. Board.
6. Lay cabinet face down on some protective material.
7. Remove 4 CRT mounting screws (197).
8. Remove CRT from cabinet front.
9. To Install new CRT, reverse above procedure.
10. Perform purity and convergence adjustments.

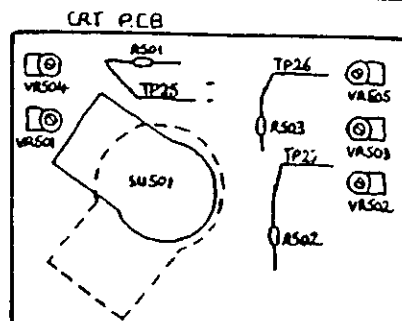
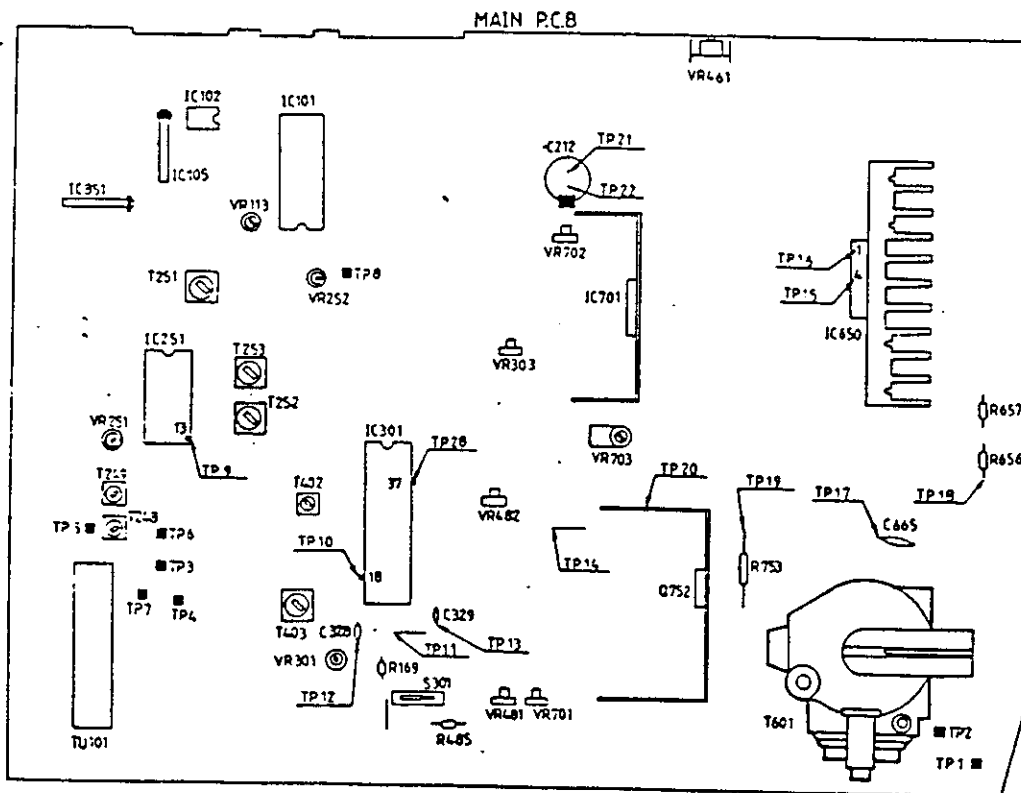

TEST POINT LOCATIONS

MATSUI 1436

COLOUR TELEVISION

INSTALLATION AND SERVICE INSTRUCTIONS

CAUTION: Use an Isolation transformer when performing any service on this chassis.

SHUTDOWN CIRCUIT

When the high voltage rises , there are simultaneous voltage increases developed at terminal 4 of the Horizontal Output Transformer (T601) and applied to pin 30 of IC301 .If excessive high voltage is produced, the increased voltage developed exceeds the rating of zener diode D485 causing the Horizontal Oscillator to stop functioning and the high voltage system is then shut down.

HORIZONTAL HOLD ADJUSTMENT

1. Properly tune in local station.
2. Short the TP28 to TP11.
3. Adjust the Horizontal hold (VR481) to obtain minimum movement of the picture.
4. Remove the short from TP28 and TP11.

VERTICAL SIZE AND LINEARITY AND ADJUSTMENT

1. Adjust Vertical Size control (VR701) so that the picture fills the picture opening from top to bottom and is proportionate to the width.
2. Adjust Vertical Linearity (VR702) so that the picture has no distortion all over Screen
3. Adjust Vertical center control (VR703) so that the vertical marker scale of top and bottom become equal.

FOCUS ADJUSTMENT

Adjust focus control, on the horizontal output transformer (T601), for maximum overall definition and fine picture detail.

SUB BRIGHT ADJUSTMENT

1. Connect Test Pattern Generator to EXT. antenna socket.
2. Connect positive lead of voltmeter to TP1 and negative lead to TP2.
3. Set Contrast controls to minimum and Brightness controls to maximum position.
4. Adjust Sub Brightness control (VR303) to obtain 0.85V on voltmeter.

APC ADJUSTMENT

1. Connect Color Bar Generator to EXT. antenna socket.
2. Connect positive lead of voltmeter to TP10 and negative lead to TP11.
3. Adjust APC (VR301) to obtain 8.4V on voltmeter.

RF AGC ADJUSTMENT

1. Connect TV Channel Signal Generator to EXT. antenna socket.
Adjust TV Channel Signal Generator output level for (60dB μ) channel 2.
2. Connect positive lead of DC Voltmeter to TP7 and negative lead of DC Voltmeter to TP6.
3. Adjust VR251 so that the DC Voltmeter reading is 6.5V \pm 0.1V.

SIF DET ADJUSTMENT

1. Connect Monosce (input 60dB μ), Sound (mod. freq:400Hz, Deviation:50KHz DEV) Generator to Ext. antenna socket.
2. Connect positive lead of Distortion to speaker \oplus and negative lead of Distortion to speaker \ominus .
3. Adjust T251 to min. Distortion and max output.

ON SCREEN DISPLAY POSITION ADJUSTMENT

1. Connect TV Test Pattern Generator (Color Bar signal) to Aerial Terminal (J1) through TV Channel Signal Generator.
2. Press the By switch (S101) to TV on.
3. Press the Preset switch (S107) To enter prespitting mode. Band Indication, channel position number , color system Indication and bars appear on the screen.
4. Adjust VR113 so that the right and left side of Bars may be the same as shown in Fig.1A.

BURST CLEANING ADJUSTMENT

1. Connect Color Bar Generator to Ext. antenna socket.
2. Connect Oscilloscope to TP12 (R-Y output) and TP11 (ground).
3. Adjust T402 so that waveform may become maximum as shown in Fig. 2.

MATSUI 1436

COLOUR TELEVISION

INSTALLATION AND SERVICE INSTRUCTIONS

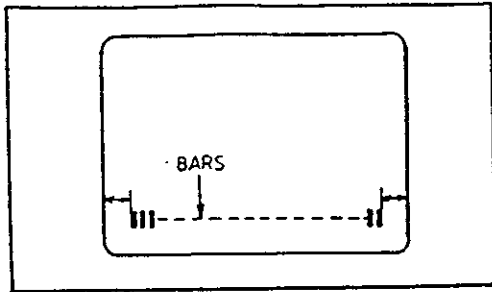

Fig. 1A

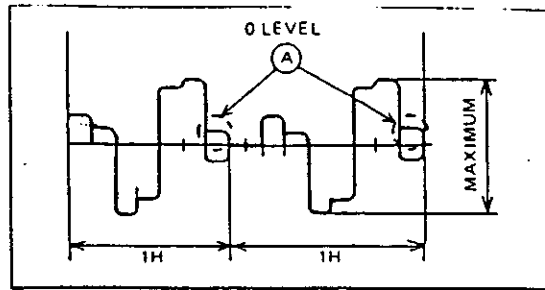

Fig. 2

CHROMA INPUT LEVEL ADJUSTMENT

1. Connect Color Bar Generator to Ext. antenna socket.
2. Connect Oscilloscope to TP 12 (R-Y output) and TP11 (ground).
3. Adjust 'A' to 0 level with VR306 as shown in Fig. 3.

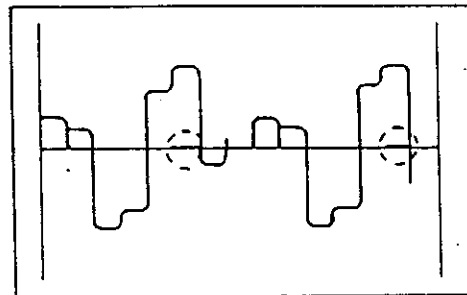
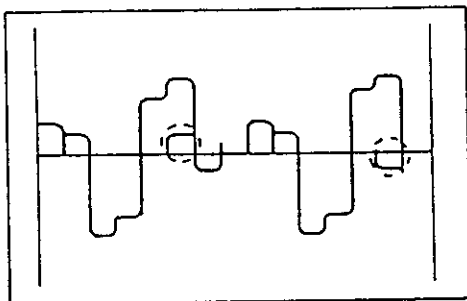

Fig. 3

PHASE ADJUSTMENT

1. Connect Color Bar Generator to Ext. antenna socket.
2. Connect Oscilloscope to TP12 (R-Y output) and TP11 (ground).
3. Adjust T403 so that waveform may be the same as shown in Fig. 4.

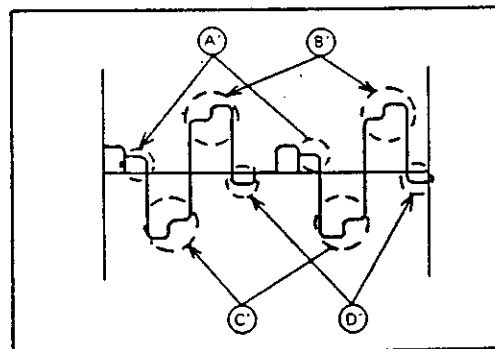
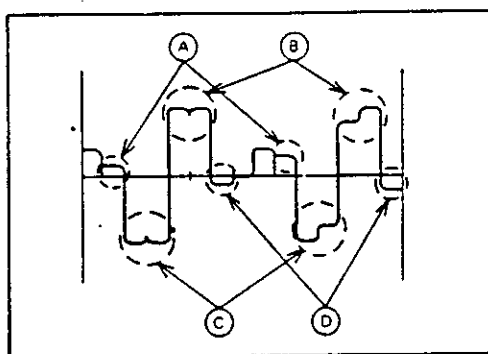

Fig. 4

COLOR PURITY ADJUSTMENT

For best results, it is recommended that the purity adjustment be made in the final receiver location. If the receiver will be moved, perform this adjustment with it facing East. The receiver must have been operating 15 minutes prior to this procedure and the faceplate of the CRT must be at room temperature. The following procedure is recommended while using a Dot/Bar Generator.

1. Check for correct location of all neck components. (Refer to Fig. 5)
2. Rough-in the static convergence at the center of the CRT, as explained in the static convergence procedure.
3. Contrast control to maximum CCW position and Brightness control as far CW as possible without causing the picture to "bloom".
4. Rotate the Red Color Cut Off (VR505) and Blue Color Cut Off (VR502) controls to maximum CCW position. Rotate the Green Color Cut Off control (VR503) sufficiently in a CW direction to produce a green raster.
5. Loosen the deflection yoke clamp screw and pull the deflection yoke toward the rear of the CRT.

MATSUI 1436

COLOUR TELEVISION

INSTALLATION AND SERVICE INSTRUCTIONS

6. Begin the following adjustment with the tabs on the round purity magnet rings set together. Slowly separate the two tabs while at the same time rotating them to adjust for a uniform green vertical band at the center of the CRT screen.
7. Carefully slide the deflection yoke forward to achieve green purity (Uniform green screen).

NOTE: Center purity is obtained by adjusting the tabs on the round purity magnet rings, outer edge purity is obtained by sliding the deflection yoke forward.

8. Check for red and blue field purity by reducing the setting of the Green Color Cut Off (VR503) control and alternately increasing the setting of the Red and Blue Color cut Off (VR505 and VR502) controls and repeat steps 2 through 7, if required.
9. Tighten deflection yoke clamp screw.
10. Perform BLACK AND WHITE ADJUSTMENT procedure.

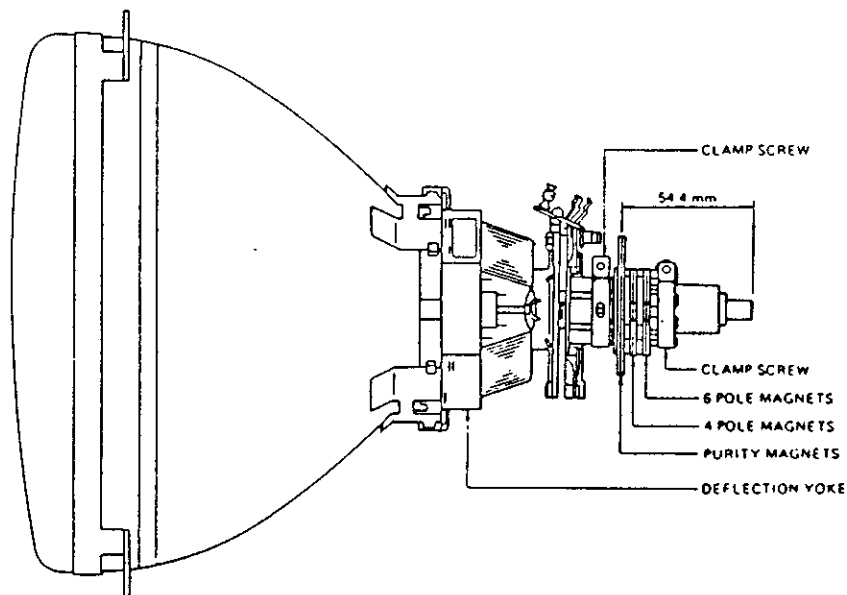

Fig. 5 Picture Tube Neck Component Location

BLACK AND WHITE ADJUSTMENT

The purpose of this procedure is to adjust the biases applied to the picture tube to obtain good black and white picture reproduction at all brightness levels while, at the same time achieving maximum useable brightness. Proper RF AGC control adjustment must be verified prior to performing this procedure.

1. With antenna connected to the receiver, tune in picture on a strong received channel. Set Color control to maximum position so that the receiver will not produce a color picture while the following adjustments are being performed.
2. Rotate the Red Color Drive (VR504) and Blue Color Drive (VR501) controls to the center of their rotation ranges.
3. Rotate the Green Color Cut Off (VR503), Red Color Cut Off (VR505) and Blue Color Cut Off (VR502) controls to the full CCW end of their rotation.
4. Set Service/TV switch (S301) to SERVICE position. Adjust the Green Color Cut Off control (VR503) for 165V DC at Test Point TP27. This voltage should be measured with an oscilloscope.
5. Rotate the Screen control (on horizontal output transformer) to the full CCW end of its rotation. Then, rotate it CW until a dim line of one pronounced color (green, red or blue) is obtained.
6. Alternately rotate the other two color cut off controls CW until a dim white line is obtained.
7. Set Service/TV switch (S301) to TV position.
8. If necessary, touch-up adjustment of the Red and Blue Color Drive controls (VR504 and VR501) to produce a uniform monochrome picture.
9. If the screen does not display good white uniformity, repeat steps 2 through 8.

MATSUI 1436COLOUR TELEVISIONSTATIC CONVERGENCE ADJUSTMENT

(Refer to Fig. 5 & 6)

IMPORTANT: Before proceeding, check location of the convergence magnet assembly on the neck of the CRT as shown in Figure 5. The rear edge of this assembly must be positioned 3/4 inch from the tip of the CRT base. If not properly positioned, convergence adjustment may be difficult, if not impossible.

1. Apply dot or crosshatch pattern from Dot/Bar Generator to receiver. Reduce setting of Brightness and/or Contrast controls to eliminate any blooming in pattern.
2. Rotate Green Color Cut Off control (VR 503) fully CCW.
3. Observe the blue and red pattern now appearing on the jCRT screen. Locate the 4pole magnet rings and separate their adjusting tabs approximately the width of one tab.
4. Rotate this pair of magnet rings as a unit (do not change spacing between tabs) to minimize the separation between the blue and red dots (lines).
5. If the blue and red dots (lines) are not completely converged at this point readjust the spacing between the two tabs to complete convergence of the blue and red dots (lines), thus producing magenta dots (lines).
6. If necessary, repeat steps 3, 4 and 5 until proper convergence is achieved.
7. Rotate Green Color Cut Off control (VR503) CW until proper green level is restored and observe the magenta (B/R) and green pattern now appearing on CRT screen.
8. Locate the 6 pole magnet rings and separate their adjusting tabs approximately the width of one tab.
9. Rotate this pair of magnet rings as a unit (do not change spacing between tabs) to minimize the separation between the magenta (B/R) and green dots (lines).
10. If the magenta and green dots (lines) are not completely converged at these points, readjust the spacing between the two tabs to complete convergence of the magenta and green dots (lines).
11. If necessary, repeat steps 8, 9 and 10 until proper convergence is obtained. To prevent accidental misadjustment of the magnets, apply a stripe of paint across all six rings and on to the neck of the CRT.

DYNAMIC CONVERGENCE

(Refer to Fig. 7)

Dynamic convergence (convergence of the three color fields at the edges of the CRT screen) is accomplished by proper insertion and positioning of three rubber wedges between the edge of the deflection yoke and the funnel of the CRT. This is accomplished in the following manner.

1. Switch receiver ON and allow it to warm up for 15 minutes.
2. Apply crosshatch pattern from Dot/Bar Generator to receiver. Observe spacing between lines around edges of CRT screen.
3. For the misconvergence shown in Figure 7 (A), tilt the deflection yoke down and insert wedge A between deflection yoke and CRT.
4. For the misconvergence shown in Figure 7 (B), tilt the deflection yoke up and insert wedge B between deflection yoke and CRT.
5. For the misconvergence shown in Figure 7 (C), tilt left side of the deflection yoke and slightly insert the wedge C between deflection yoke and CRT. Then, deeply insert wedges A and B between deflection yoke and CRT.
6. For the misconvergence shown in Figure 7 (D), tilt right side of the deflection yoke and deeply insert wedge C between deflection yoke and CRT. Then, slightly insert and/or extract wedges A and B between deflection yoke and CRT.
7. Alternately change spacing between the three wedges until proper dynamic convergence is obtained.
8. Use a strong adhesive tape to firmly secure each of the three rubber wedges to the funnel of the CRT.

MATSUI 1436

COLOUR TELEVISION

CONVERGENCE ADJUSTMENT

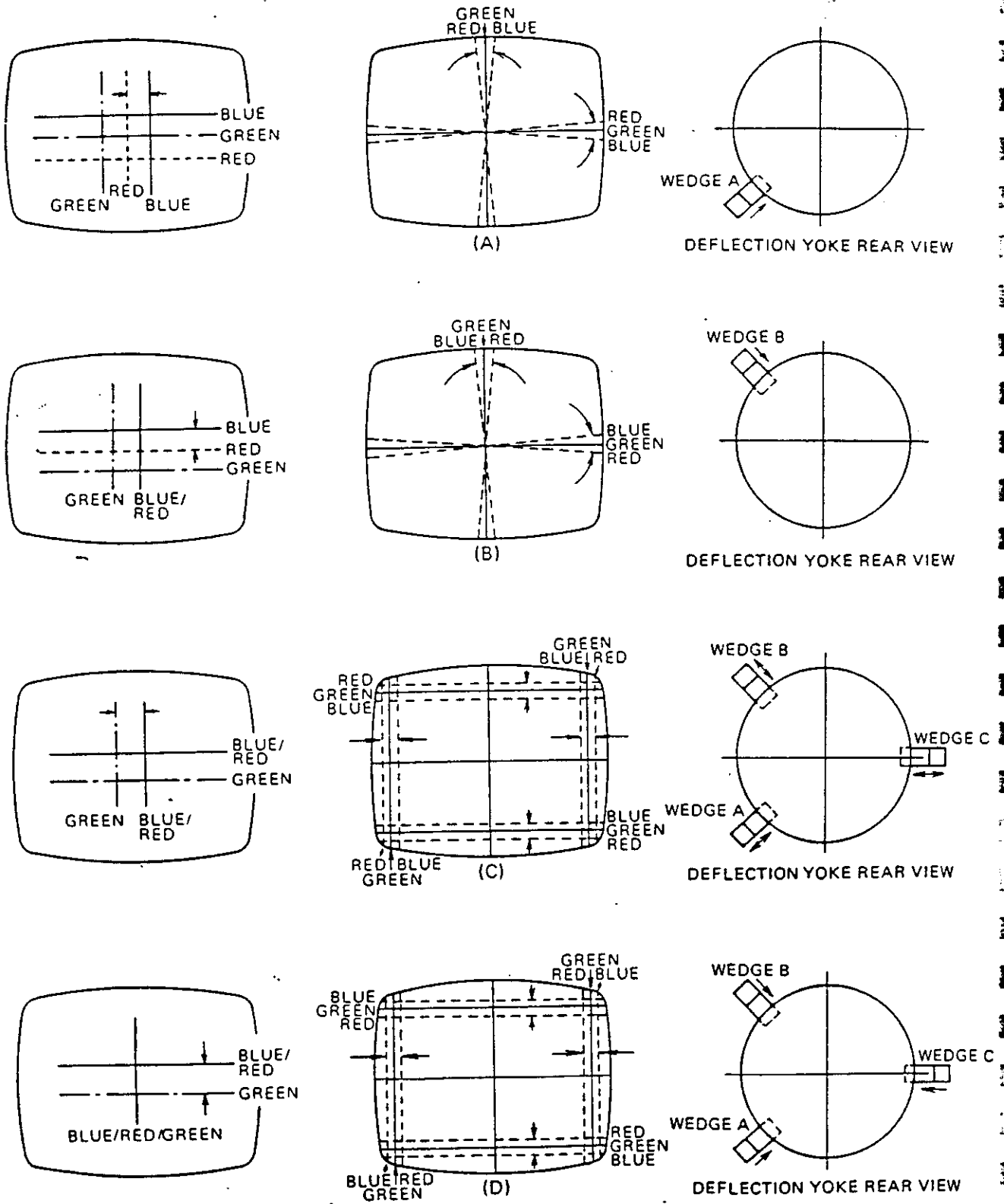

Fig. 6 Static Convergence Adjustment

Fig. 7 Dynamic Convergence Adjustment

MATSUI 1436

COLOUR TELEVISION

GENERAL ALIGNMENT INSTRUCTIONS

EQUIPMENT

The test equipment specified below, or its equivalent, is required to properly perform the alignment procedures which are outlined on the following pages. Use of equipment which does not meet these requirements may result in the inability to properly align the receiver. A warm-up period of at least 15 minutes should be allowed for proper stabilization of equipment such as Generators and Oscilloscope. It is essential that the proper bias values, as specified, are maintained during alignment to insure the proper results.

EQUIPMENT TERMINATIONS

The alignment pads provided with the equipment specified are designed for correct matching of the equipment to the circuits involved. Failure to use proper matching will result in responses which cannot be depended upon as representing the true operation of the receiver.

SIGNAL OVERLOAD

Use of excessive signal from the Sweep/Marker Generator can cause overloading of the receiver circuits. To determine that this condition is not present and that the response curve is true, turn the Sweep/Marker Generator output to zero and then gradually increase the output until a response is obtained. Further increase of the sweep output should not change the configuration of the response except in amplitude. If the response changes in configuration, such as flattening at the top or dropping below the base line at the bottom, decrease the sweep output to restore the proper configuration.

The Oscilloscope gain should be run as high as possible to maintain a usable pattern with the peak-to-peak values specified, thus requiring a lower output from the Sweep/Marker Generator and less chance of overload. Insertion of markers from the Sweep/Marker Generator should not cause distortion of the response. The markers should be kept as small as possible and still remain visible.

RECEIVER CHASSIS PREPARATION

All covers and shields should be in their proper place before any alignment procedures or performance checks are attempted.

CAUTION: Remove the AC Power plug before making any test equipment connections.

VIDEO IF & AFC ALIGNMENT

TEST EQUIPMENT

To facilitate service and alignment of this chassis, it is recommended that the following test equipment be used to assure proper performance.

ISOLATION TRANSFORMER

COLOR BAR/DOT/CROSS-HATCH GENERATOR

DEMAGNETIZING COIL

DIGITAL MULTIMETER

OSCILLOSCOPE Wide band oscilloscope.

IF-CHROMA-VSM SWEEP/MARKER GENERATOR To Provide proper sweep and marker frequencies and bias voltages required for alignment.

MATSUI 1436

COLOUR TELEVISION

VIDEO IF & AFC SWEEP ALIGNMENT

TEST-EQUIPMENT CONNECTIONS

GENERALRead the General Alignment Instructions before proceeding with this alignment.
 CAUTION:Before making any test equipment connections to the receiver chassis,disconnect the AC power plug.
 ISOLATION TRANSFORMER.....Receiver AC power cord must be connected to an Isolation Transformer.
 OSCILLOSCOPE.....Set AC-DC-GND switch to AC. Set VOLTS DIV. switch to.1 (if necessary, set to another range) and TIME DIV. switch to .EXT. Install connecting cables between the H and V inputs and the H and V output of the IF Sweep/Marker Generator.

IF SWEEP/MARKER GENERATOR...Set SWEEP WIDTH control of full CW rotation with knob pushed in; set FUNCTION switch to TV IF SWEEP; switch on 39.5 MHz crystal markers; adjust MARKER output to produce usable marker size. Connect Red lead of Sweep Output Probe (PR-16A) to test point TP5; connect Black lead to test point TP6. Connect Red lead of Probe Input Detector (PR-15) to test point TP4. Black lead to test point TP3 Set SWEEP CENTER control to 3 o'clock position with knob pushed in,then readjust to properly center horizontal location of pattern on Oscilloscope screen.

STEP	ADJUSTMENT	COMPONENT	PROCEDURE
1			Remove the short from TPA on Main P.C. board, as shown in Fig 11.
2	39.5 MHz Trap	T252	Adjust T252 to obtain a response curve that approximates the curve illustrated in Fig.12.Adjust T252 to position the 39.5 MHz
3			Connect red lead of probe input detector(PR-15)to test point TP8 and black lead to test point TP6.
4	39.5 MHz Trap	T253	Adjust T253 to obtain a response curve that approximates the curve illustrated in Fig. 13.
5			Connect Digital Multimeter to TP8 and TP6.
6	AFT	T253	Adjust T253 to obtain 2.8V+ - 0.1V on Digital Multimeter.
7			Short the TPA on Main P.C. board.
8			Remove 100 μ F 16V electrolytic capacitor.
9			Connect Digital Multimeter to TP7 and TP6.
10	AGC	VR251	Adjust VR251 to obtain 6.5V+ - 0.1V on Digital Multimeter.

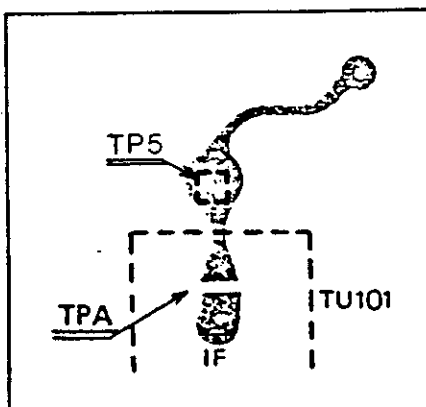

Fig.11

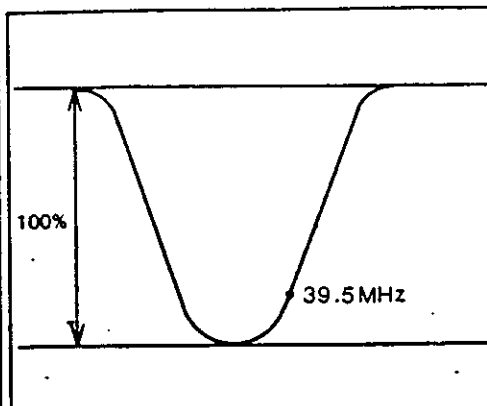

Fig.12

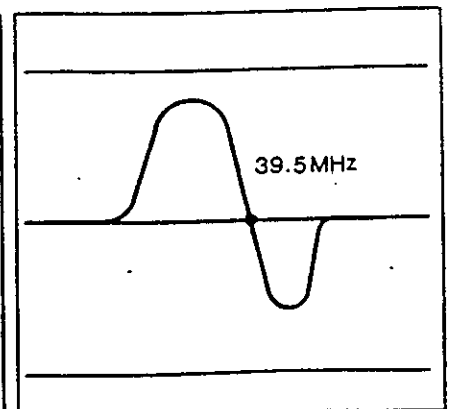
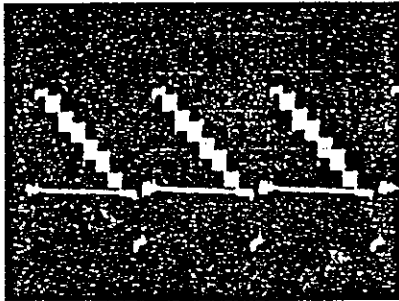

Fig.13

MATSUI 1436

COLOUR TELEVISION

CHASSIS WAVEFORMS



WF-1 2.0Vp-p (H)

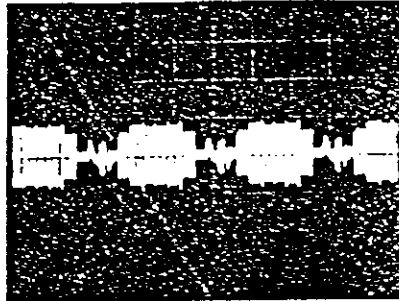

WF-2 0.15Vp-p (H)

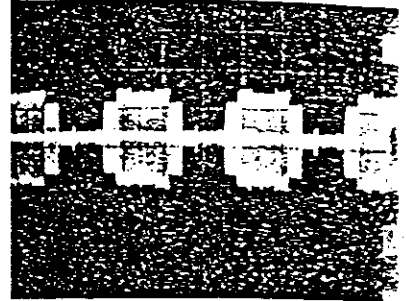

WF-3 0.25Vp-p (H)

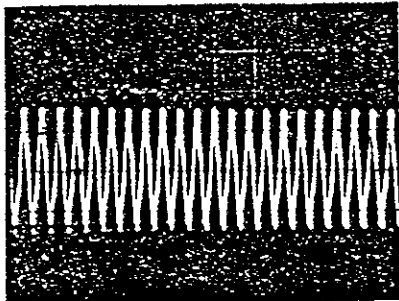

WF-4 1.5Vp-p (H)

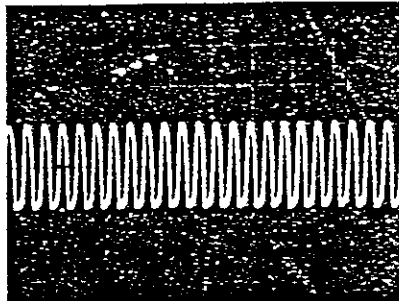

WF-5 4.5Vp-p (H)

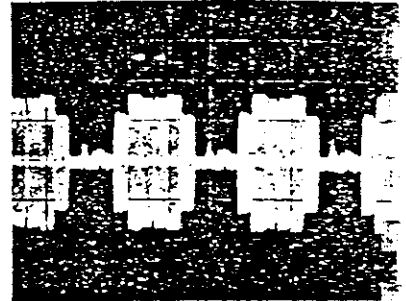

WF-6 0.18Vp-p (H)

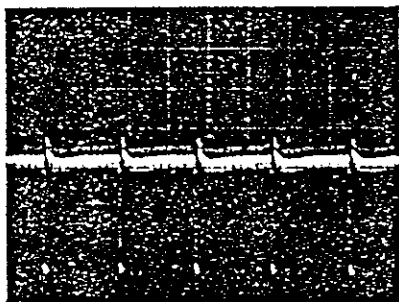

WF-7 1.5Vp-p (V)

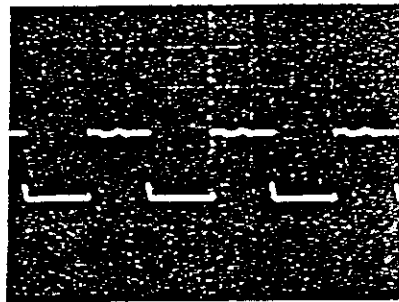

WF-8 0.8Vp-p (H)

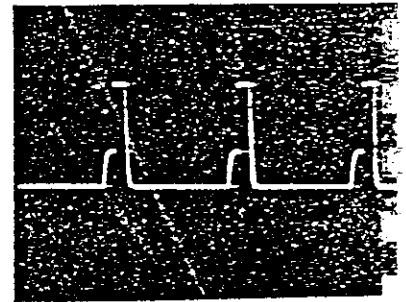

WF-9 5.2Vp-p (H)

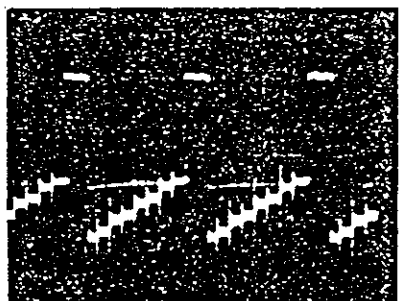

WF-10 4.5Vp-p (H)

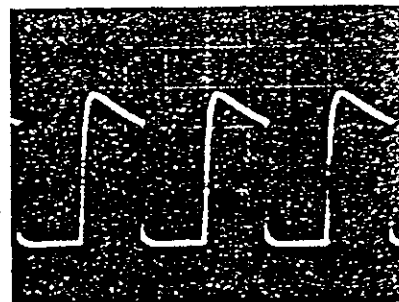

WF-11 190Vp-p (H)

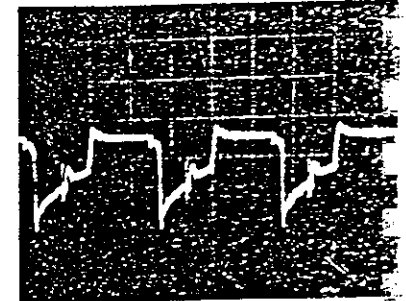

WF-12 4Vp-p (H)

MATSUI 1436

COLOUR TELEVISION

CHASSIS WAVEFORMS

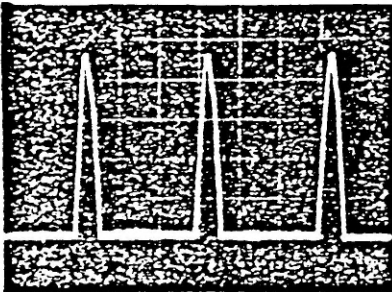

WF-13 1000Vp-p (H)

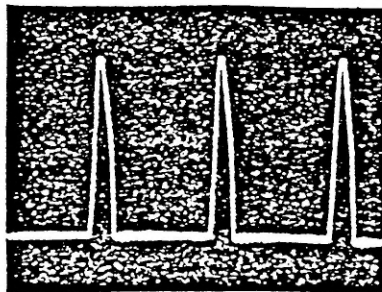

WF-14 22.3Vp-p (H)

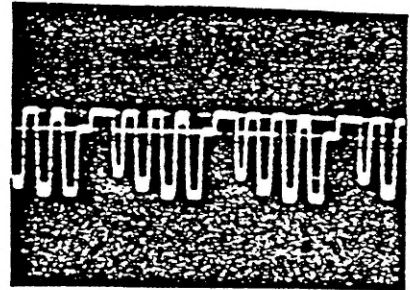

WF-15 110Vp-p (H)



WF-16 100Vp-p (H)



WF-17 110Vp-p (H)

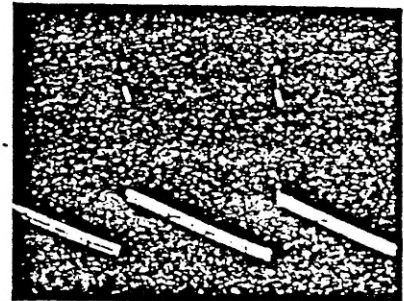

WF-18 50Vp-p (V)

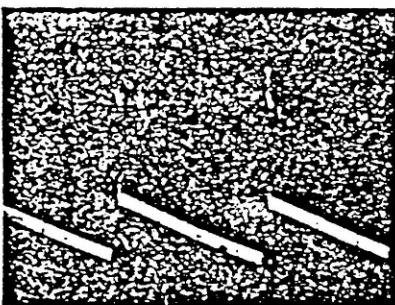

WF-19 50Vp-p (V)

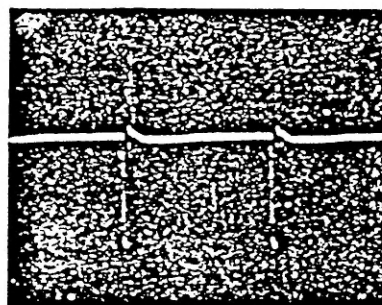

WF-20 1.4Vp-p (V)

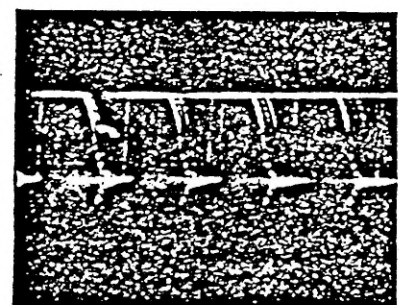

WF-21 120Vp-p (H)

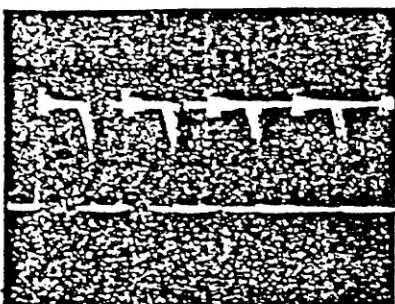

WF-22 560Vp-p (H)

NOTES :

WAVEFORMS SHOWN WERE PRODUCED USING A PATTERN GENERATOR WITH ITS CONTROL SET TO PRODUCE A COLOR BAR SIGNAL AND A WIDEBAND OSCILLOSCOPE WITH LOW CAPACITY PROBE TO PREVENT LOADING. RECEIVER OPERATING CONTROLS WERE ADJUSTED TO PRODUCE A NORMAL PICTURE. OSCILLOSCOPE SWEEP WAS SET AT 5 mS FOR VERTICAL WAVEFORMS AND 20 μS FOR HORIZONTAL WAVEFORMS. PEAK-TO-PEAK VOLTAGES INDICATED MAY VARY DEPENDING ON CALIBRATION OF TEST EQUIPMENT, CHASSIS PARTS TOLERANCES AND CONTROL SETTINGS. ALL WAVEFORMS TAKEN WITH WIDEBAND OSCILLOSCOPE.

VOLTAGE AND WAVEFORMS ARE TAKEN WITH COLOR BAR SIGNAL GENERATOR APPLIED TO THE SET.

WAVEFORMS 1 THRU 22 USE CHASSIS GROUND.

INTENTIONALLY LEFT BLANK

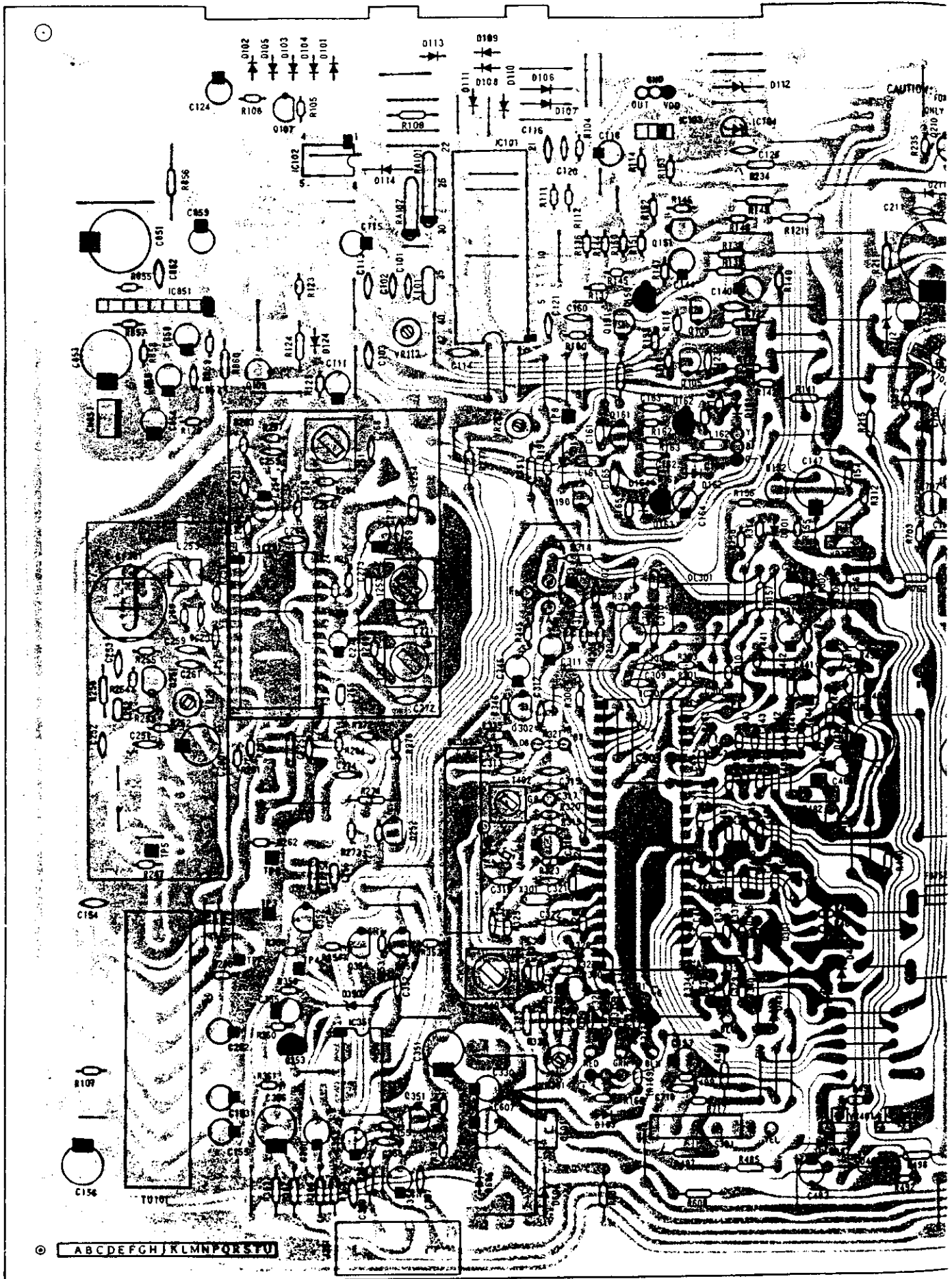

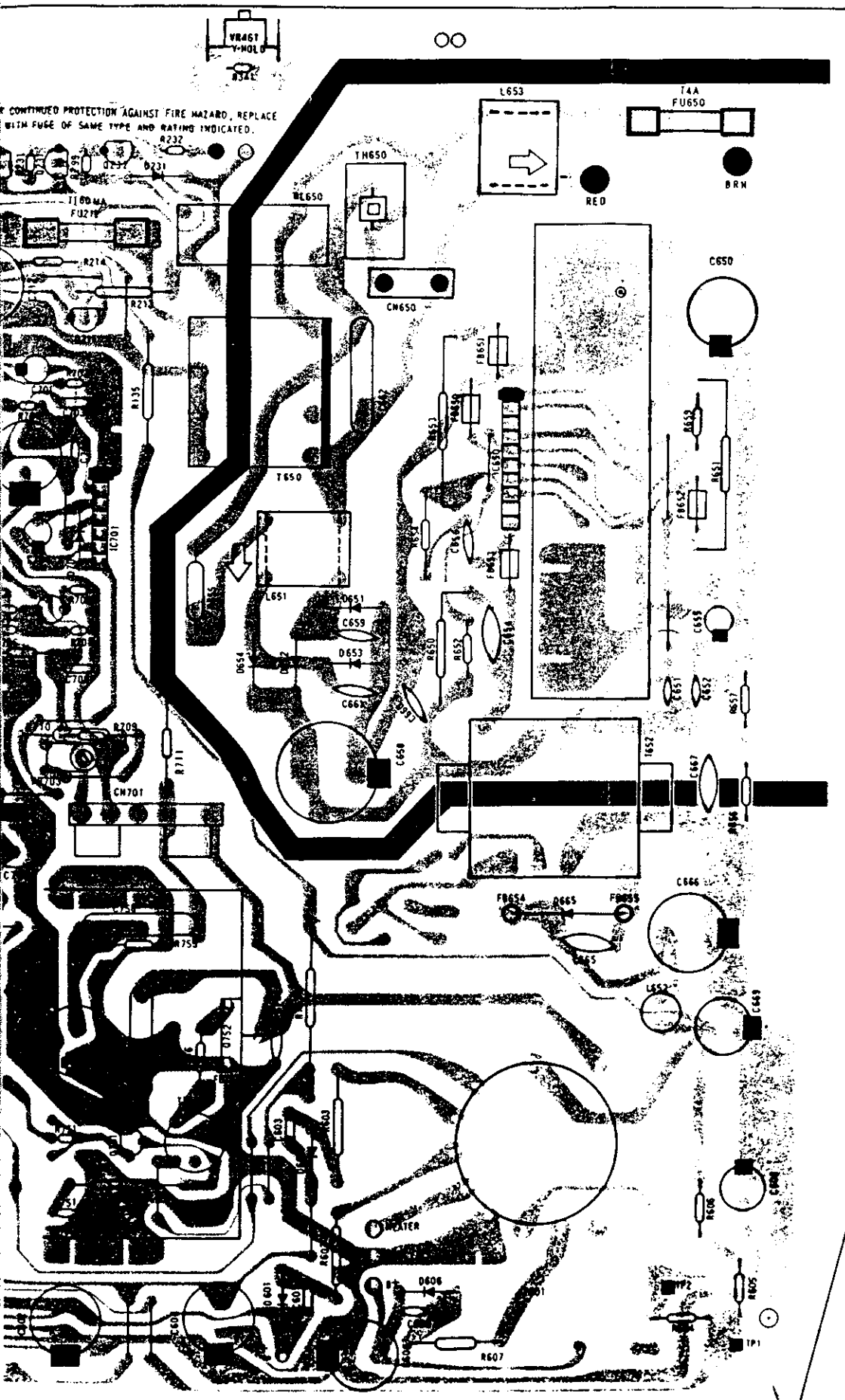

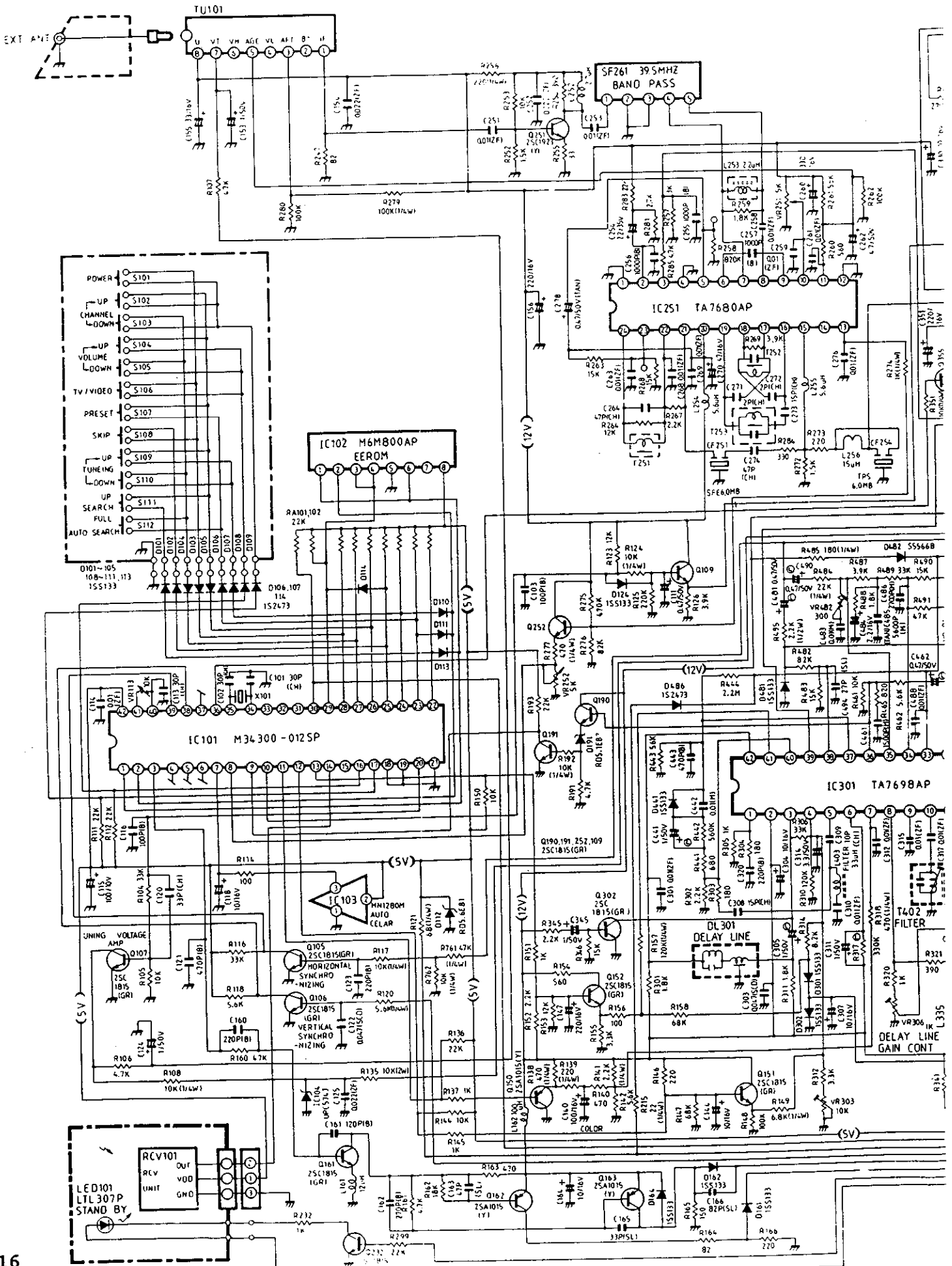

COLOUR TELEVISION

SCHEMATIC DIAGRAM

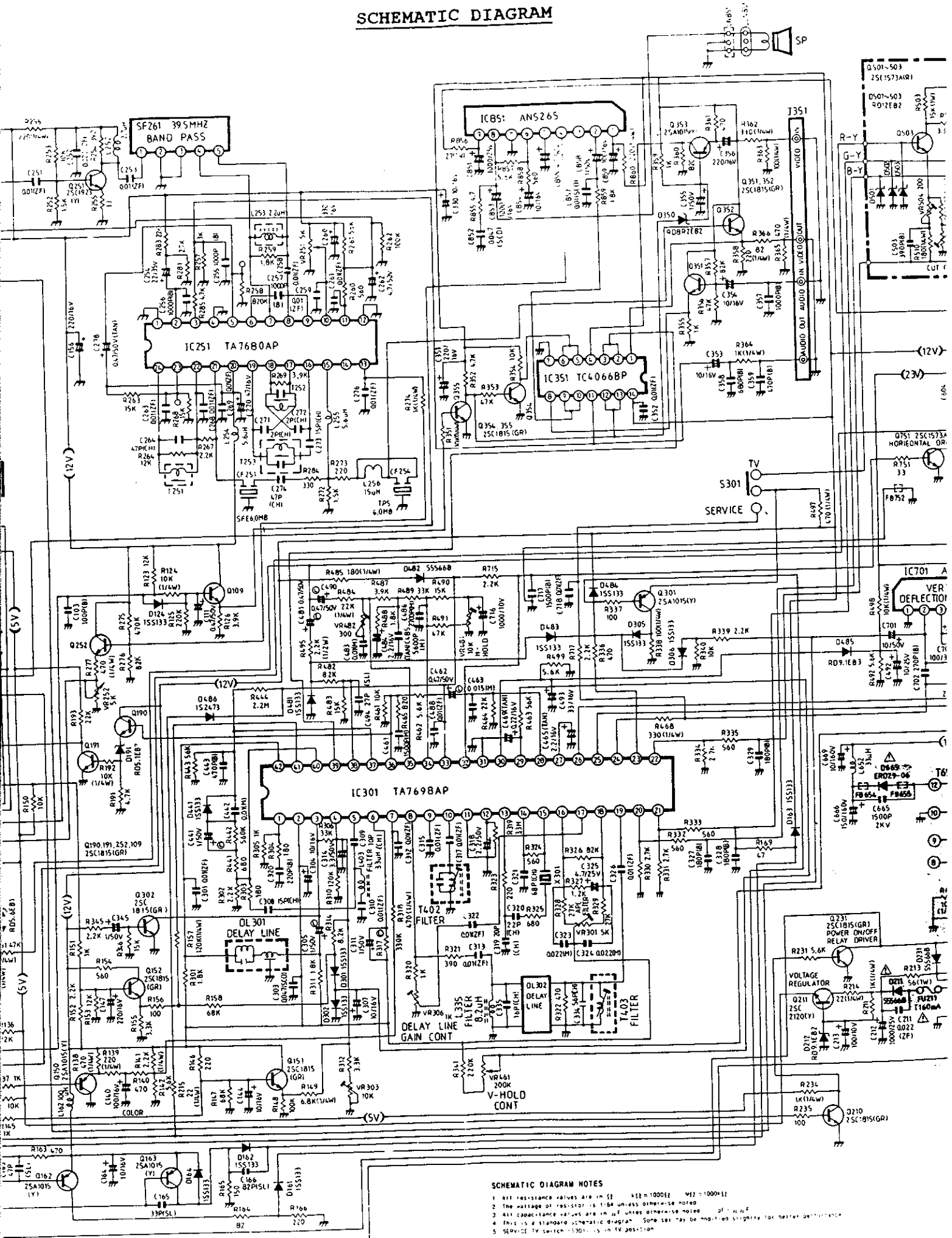

SCHEMATIC DIAGRAM NOTES

- 1 All resistance values are in Ω $k\Omega = 1000\Omega$ $M\Omega = 1000k\Omega$
- 2 The wattage of resistor is 1/8W unless otherwise noted
- 3 All capacitance values are in μF unless otherwise noted
- 4 This is a standard schematic diagram. Some test points may be different in other models.
- 5 SERVICE TV service is on the TV position.

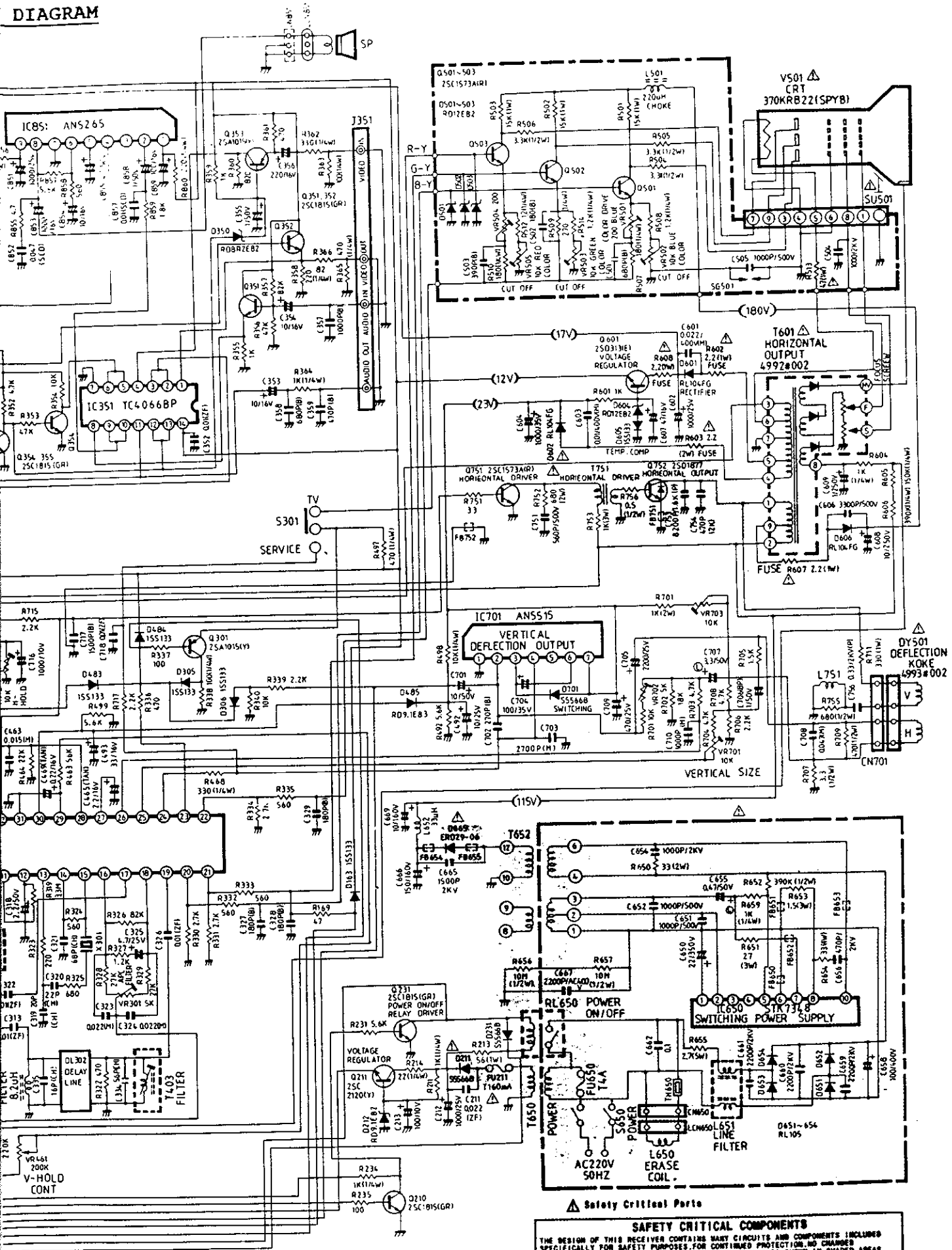

SCHEMATIC DIAGRAM NOTES

1. All resistance values are in Ω unless otherwise noted.
2. All capacitance values are in μF unless otherwise noted.
3. This is a standard schematic diagram. Some parts may be modified slightly for better performance.
4. SERVICE TV switch (S301) is in TV position.

SAFETY CRITICAL PARTS

SAFETY CRITICAL COMPONENTS

THE DESIGN OF THIS RECEIVER CONTAINS MANY CIRCUITS AND COMPONENTS INCLUDED SPECIFICALLY FOR SAFETY PURPOSES. FOR CONTINUED PROTECTION, NO CHANGES SHOULD BE MADE TO THE ORIGINAL DESIGN AND COMPONENTS SHOWN IN SHADDED AREAS IN THE SCHEMATIC SHOULD BE REPLACED WITH EXACT FACTORY REPLACEMENT PARTS. THE USE OF UNAUTHORIZED SUBSTITUTE PARTS MAY CREATE A SHOCK, FIRE, OR EXPLOSION OR OTHER HAZARD. SERVICE SHOULD BE PERFORMED BY QUALIFIED PERSONNEL ONLY.

RELIABILITY AND PERFORMANCE FOR CONTINUED RELIABILITY AND PERFORMANCE, EXACT FACTORY REPLACEMENTS ARE RECOMMENDED FOR ALL OTHER PARTS REPLACED. IF A SUBSTITUTE MUST BE USED, BE SURE ITS QUALITY AND SPECIFICATIONS ARE IDENTICAL TO THE ORIGINAL PART.

MATSUI 1436

COLOUR TELEVISION

BLOCK DIAGRAM

IC101 (M3430001)

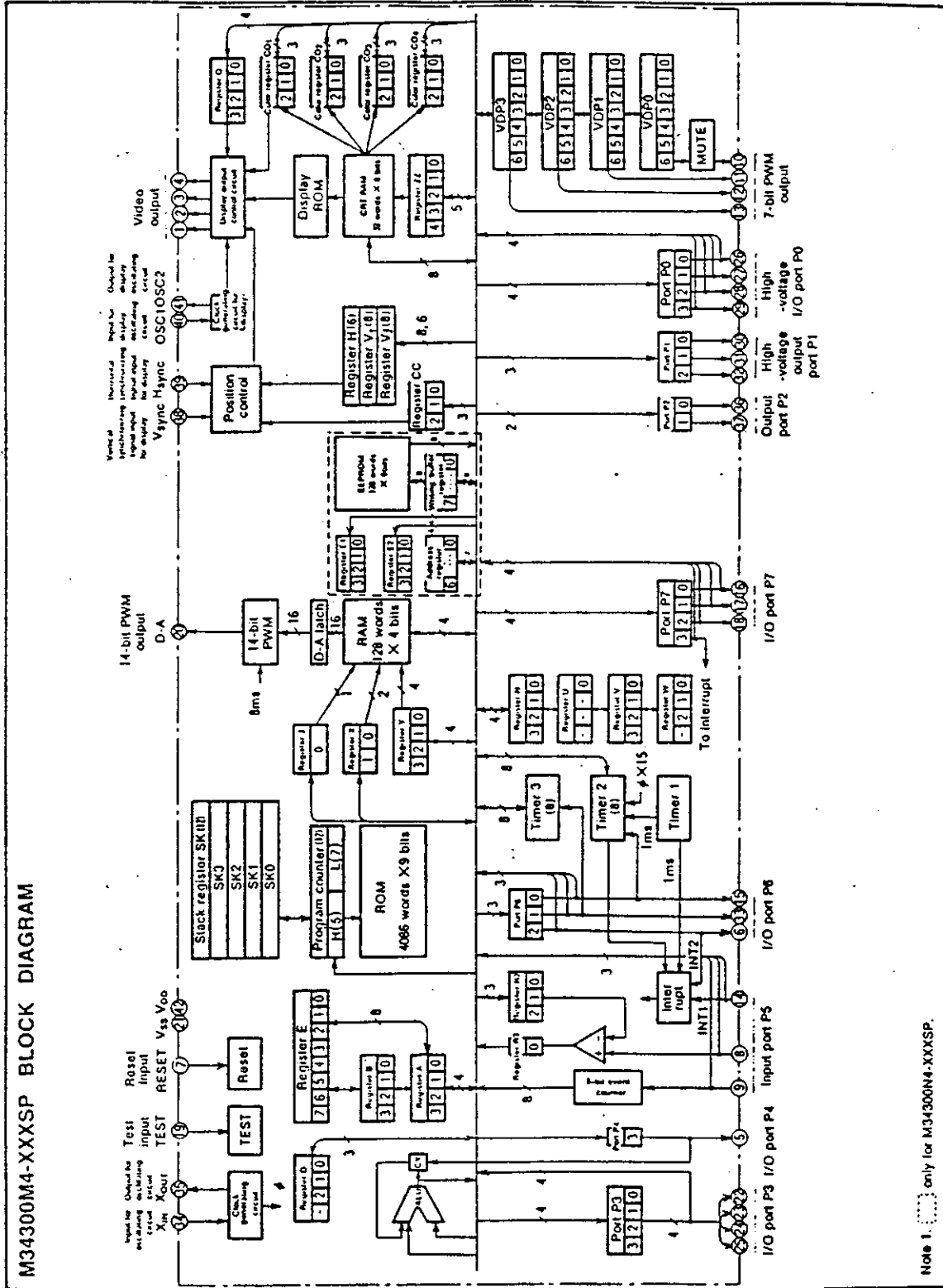

Note 1. only for M34300M4-XXXSP.

INTENTIONALLY LEFT BLANK

IC BLOCK DIAG

IC102 [M58659P]

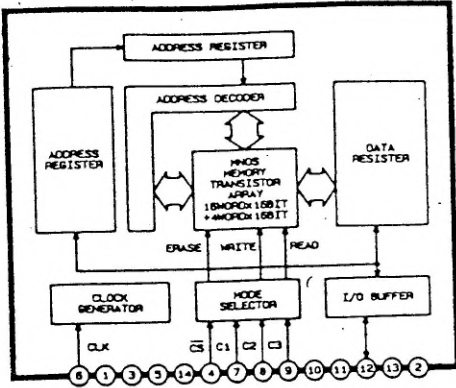

IC351 [TC4066BP]

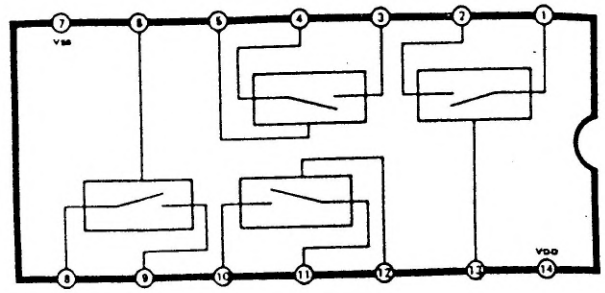

IC103 [MN1280M]

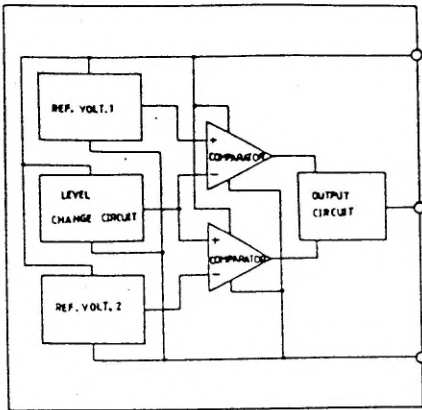

IC650 [STK7348]

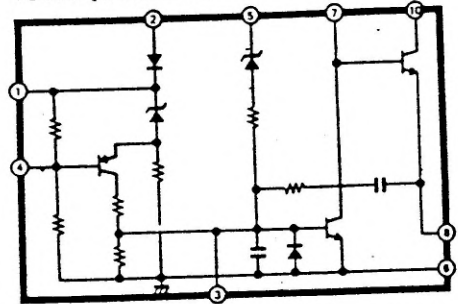

IC701 [AN5515]

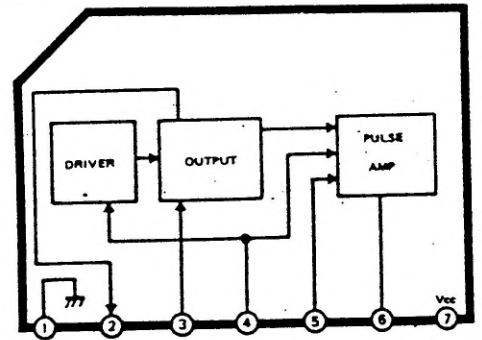

IC251 [TA7680AP]

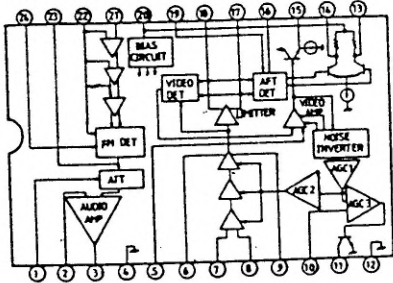

IC301 [TA7698AP]

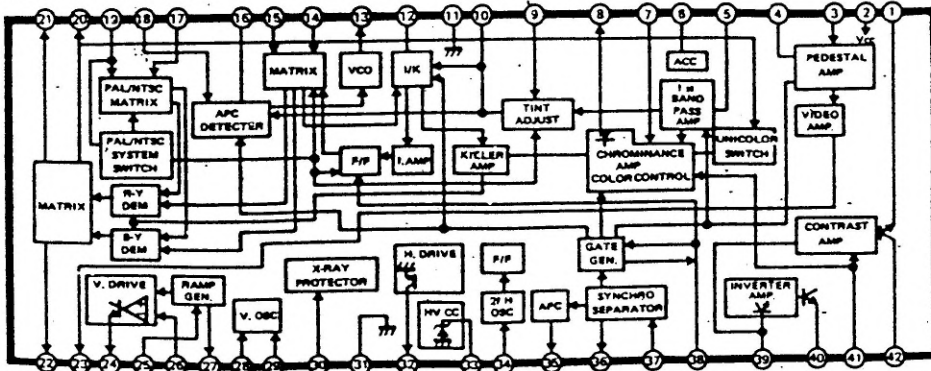

IC851 [ANS265]

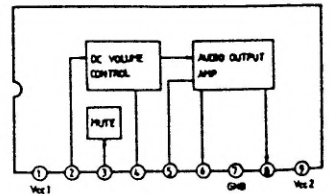

COLOUR TELEVISION

IC BLOCK DIAGRAM/VOLTAGE CHARTS

IC351 [TC4066BP]

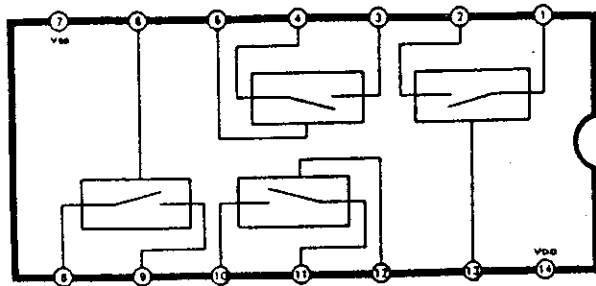

IC650 [STK7348]

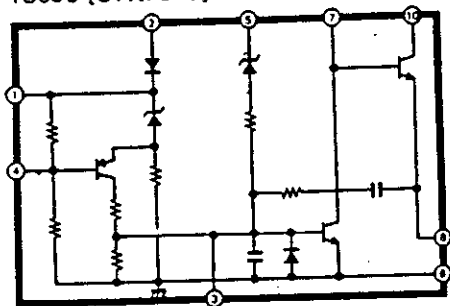

IC701 [AN5515]

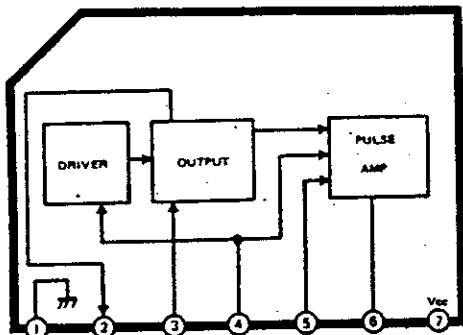

TERMINAL NO.	1	2	
IC 101	5.43	5.43	-
TERMINAL NO.	17	18	1
IC 101	5.4	0	0
TERMINAL NO.	33	34	3
IC 101	1.7	2.4	2
TERMINAL NO.	1	2	
IC 102	5.43	5.4	0
IC 103	0	5.3	5
IC 104	0	31.8	
IC 251	0	2.7	7
TERMINAL NO.	17	18	1
IC 251	8.2	8.2	4
TERMINAL NO.	1	2	
IC 301	4.7	12.2	4
TERMINAL NO.	17	18	1
IC 301	4.2	8.5	4
TERMINAL NO.	33	34	3
IC 301	8.4	4.8	4
TERMINAL NO.	1	2	
IC 351	3.3	3.2	3
IC 650	39.6	0	0
IC 701	0.3	11.9	25
IC 851	10.4	4.6	-

Q'NO.	Q105	Q106	Q
Operating Condition	1mV Color Bar Signal	1mV Color Bar Signal	1mV Bar
COLL	4.1	4.8	1
BASE	1.9	0.3	
EMIT	0	0	
Q'NO.	Q190	Q191	Q
Operating Condition	1mV Color Bar Signal	1mV Color Bar Signal	1mV Bar
COLL	12	4.4	
BASE	3	0.1	
EMIT	3.2	0	
Q'NO.	Q351	Q352	Q
Operating Condition	1mV Color Bar Signal	1mV Color Bar Signal	1mV Bar
COLL	12.1	12.1	1
BASE	3.9	3.9	
EMIT	3.3	3.3	1
Q'NO.	Q752		
Operating Condition	1mV Color Bar Signal		
COLL	117		
BASE	0.3		
EMIT	0		

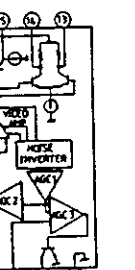
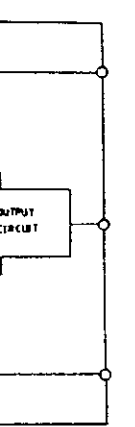
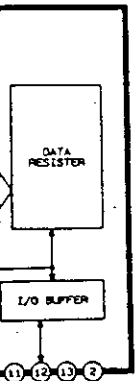

For Service Manuals
MAURITRON SERVICES
 8 Cherry Tree Road, Chinnor
 Oxfordshire, OX9 4QY.
 Tel (01844) 351694
 Fax (01844) 352554
 email:- sales@mauritron.co.uk

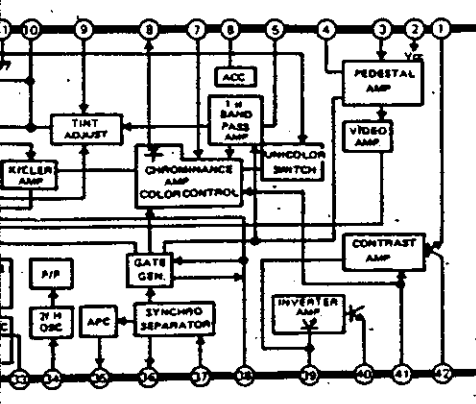

IC 851 [ANS265]

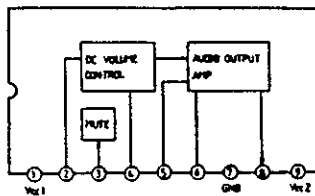

TELEVISION

AM/VOLTAGE CHARTS

TERMINAL NO.	1	2	3	4	5	6	7	8	9	10	11	12	13	14	15	16
IC 101	5.43	5.43	—	—	—	0	5.42	2.96	4.5	0.9	6.47	11.2	8.8	5.4	0	5.4
TERMINAL NO.	17	18	19	20	21	22	23	24	25	26	27	28	29	30	31	32
IC 101	5.4	0	0	4.55	0	5.4	5.4	5.4	1.1	0.2	0.2	0.2	0.6	0	0	0
TERMINAL NO.	33	34	35	36	37	38	39	40	41	42						
IC 101	1.7	2.4	2.5	0	0	4.6	4.2	0.4	0.6	5.4						
TERMINAL NO.	1	2	3	4	5	6	7	8	9	10	11	12	13	14	15	16
IC 102	5.43	5.4	0.6	0.6	—	5.4	5.4	5.4								
IC 103	0	5.3	5.3													
IC 104	0	31.8														
IC 251	0	2.7	7.5	0	7.3	5.1	5.1	5.1	5.1	6.2	4.3	0	7.7	6.1	3.8	4.4
TERMINAL NO.	17	18	19	20	21	22	23	24								
IC 251	8.2	8.2	4.4	12.1	4.6	4.6	6.9	4.6								
TERMINAL NO.	1	2	3	4	5	6	7	8	9	10	11	12	13	14	15	16
IC 301	4.7	12.2	4.5	4.3	1.1	9.7	8.4	8.7	6.2	7.6	0	9.3	9.9	3.5	3.5	8.6
TERMINAL NO.	17	18	19	20	21	22	23	24	25	26	27	28	29	30	31	32
IC 301	4.2	8.5	4.2	8.6	7.5	7.7	6.5	1.4	4.4	7.3	7.2	0.1	2.8	0	0	0.4
TERMINAL NO.	33	34	35	36	37	38	39	40	41	42						
IC 301	8.4	4.8	4.8	3.1	0.7	0.7	3.2	7.9	7.7	7.9						
TERMINAL NO.	1	2	3	4	5	6	7	8	9	10	11	12	13	14	15	16
IC 351	3.3	3.2	3.3	0	0	0	0	3.3	3	3	3	11	11	12		
IC 650	39.6	0	0.1	32.8	0.1	0	0	0.4	—	291						
IC 701	0.3	11.9	25.5	1.33	0	1.4	25									
IC 851	10.4	4.6	—	4.2	6.5	6.7	0	6.7	14.3							

Q'NO.	Q105	Q106	Q107	Q109	Q150	Q151	Q152	Q161	Q162	Q163
Operating Condition	1mV Color Bar Signal	1mV Color Bar Signal	1mV Color Bar Signal	1mV Color Bar Signal	1mV Color Bar Signal	1mV Color Bar Signal	1mV Color Bar Signal	1mV Color Bar Signal	1mV Color Bar Signal	1mV Color Bar Signal
COLL	4.1	4.8	10.6	12	6.5	12.1	10.5	12.2	12.1	12.1
BASE	1.9	0.3	0.2	0.6	0	11.9	9.3	0	0	0
EMIT	0	0	0	0	7.24	11.3	8.7	0	12.1	12.1
Q'NO.	Q190	Q191	Q210	Q211	Q231	Q232	Q251	Q252	Q301	Q302
Operating Condition	1mV Color Bar Signal	1mV Color Bar Signal	1mV Color Bar Signal	1mV Color Bar Signal	1mV Color Bar Signal	1mV Color Bar Signal	1mV Color Bar Signal	1mV Color Bar Signal	1mV Color Bar Signal	1mV Color Bar Signal
COLL	12	4.4	4.7	0.7	0.2	8.2	9.4	12	1.5	4.4
BASE	3	0.1	0	0.2	0.8	0.2	1.1	7.3	7	0
EMIT	3.2	0	0	8.1	0	0	0.4	6.6	6.9	0
Q'NO.	Q351	Q352	Q353	Q354	Q355	Q501	Q502	Q503	Q601	Q751
Operating Condition	1mV Color Bar Signal	1mV Color Bar Signal	1mV Color Bar Signal	1mV Color Bar Signal	1mV Color Bar Signal	1mV Color Bar Signal	1mV Color Bar Signal	1mV Color Bar Signal	1mV Color Bar Signal	1mV Color Bar Signal
COLL	12.1	12.1	12.1	0.6	11	129	133	131	14.6	86
BASE	3.9	3.9	0	0	0	7.7	7.5	7.5	12.1	0.4
EMIT	3.3	3.3	12.1	0	0	7.7	7.4	7.5	12.7	0
Q'NO.	Q752									
Operating Condition	1mV Color Bar Signal									
COLL	117									
BASE	0.3									
EMIT	0									

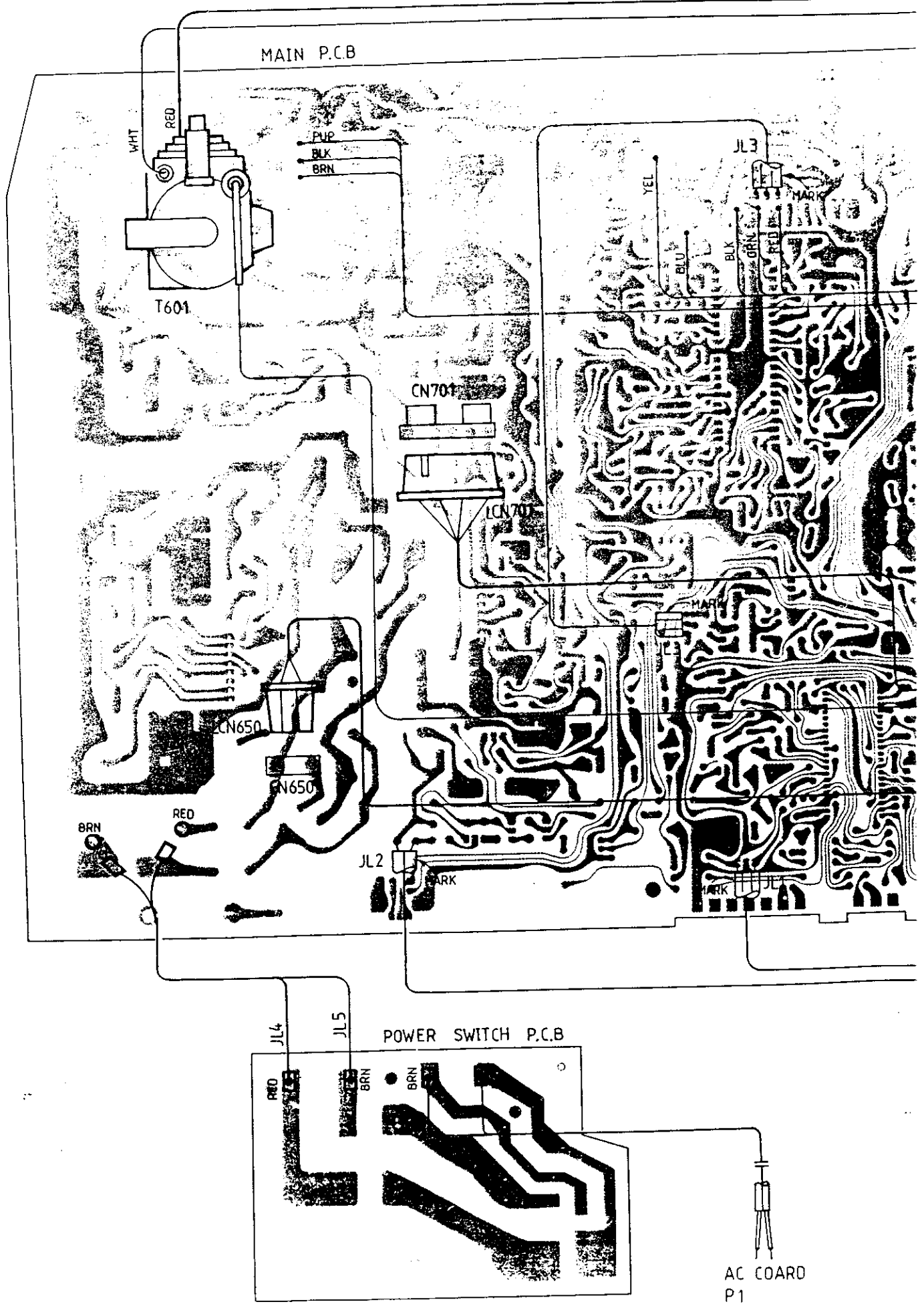

MATSUI 1436

COLOUR TELEVISION

WIRING DIAGRAM

P.C.B

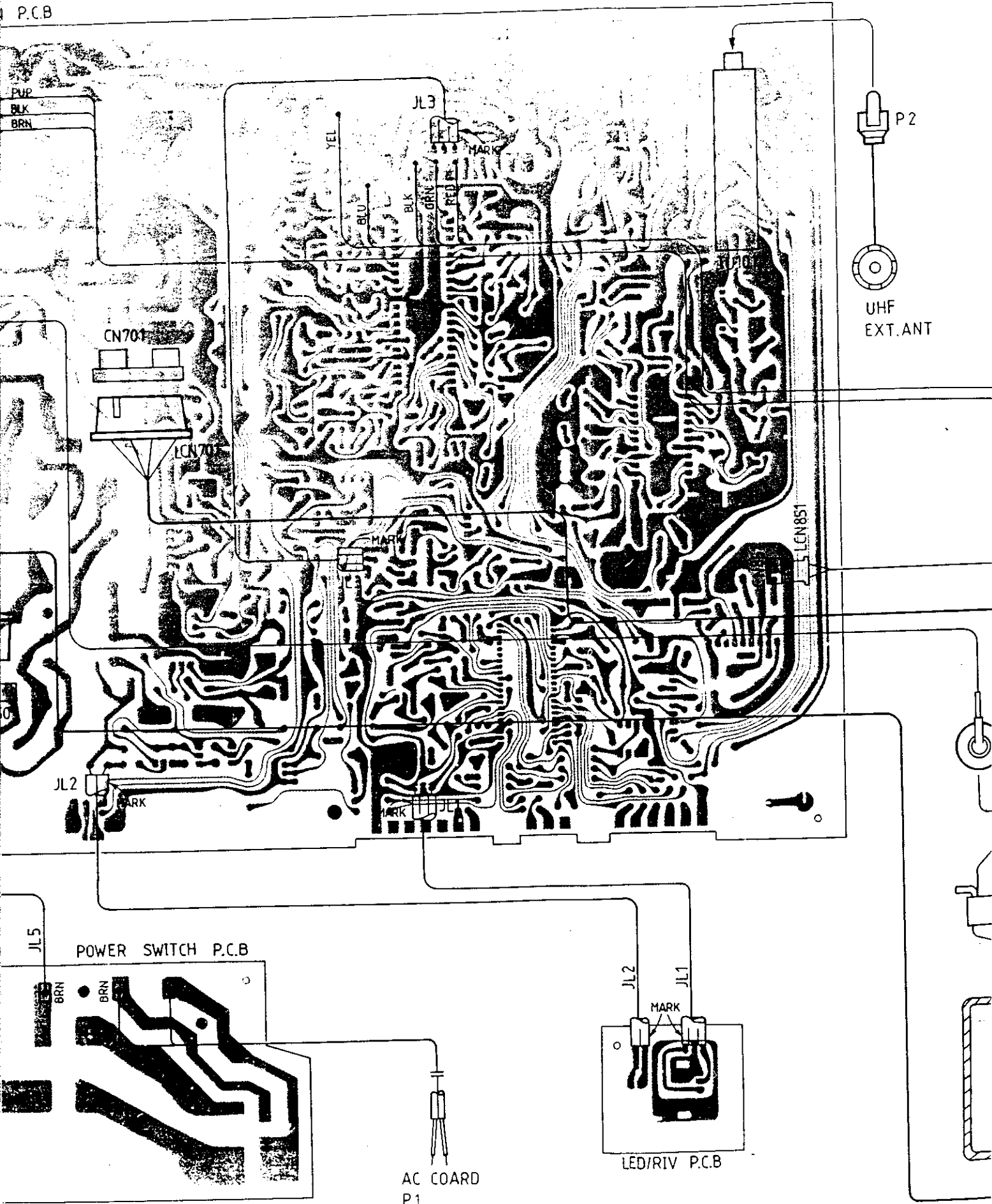

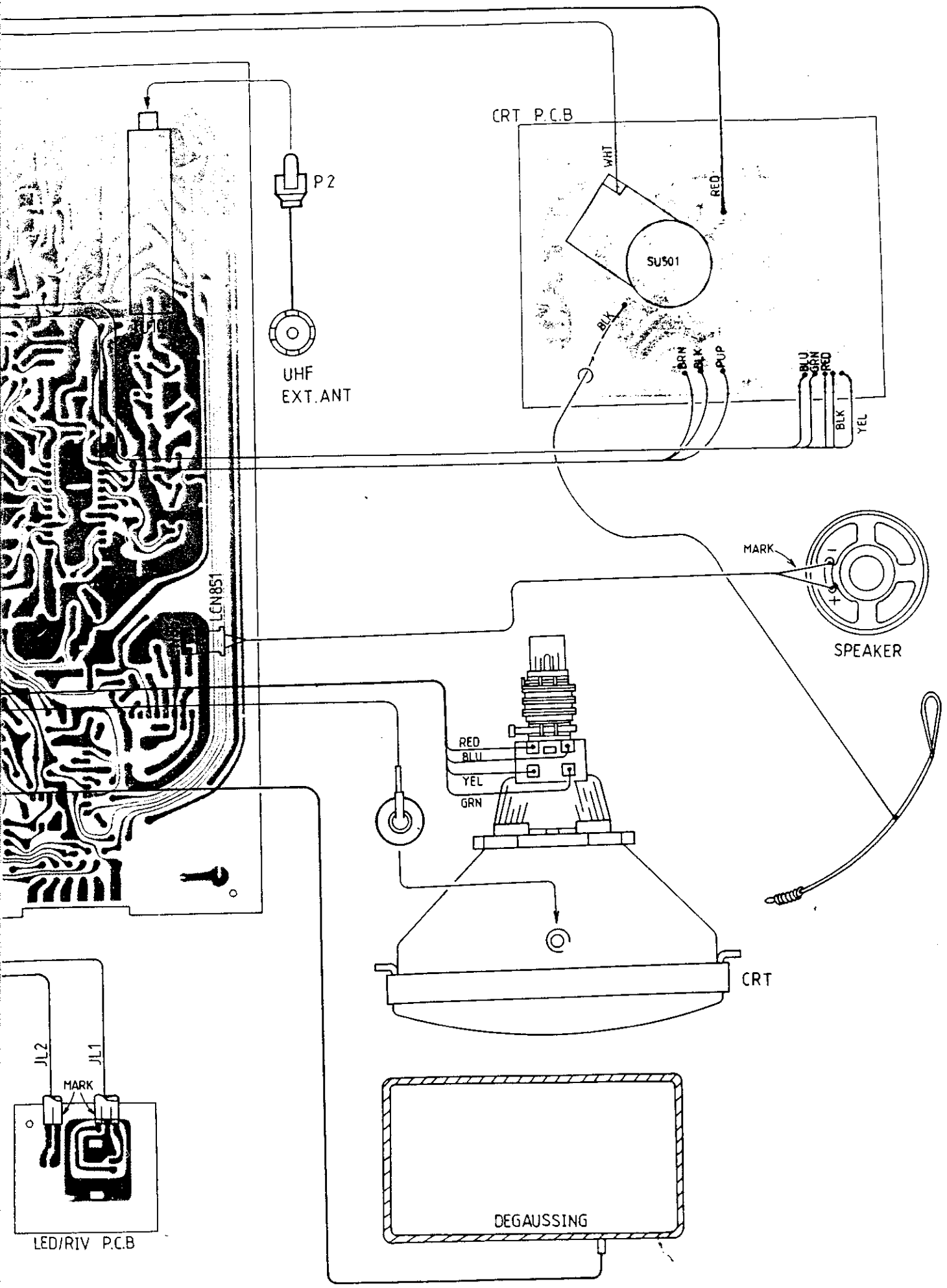

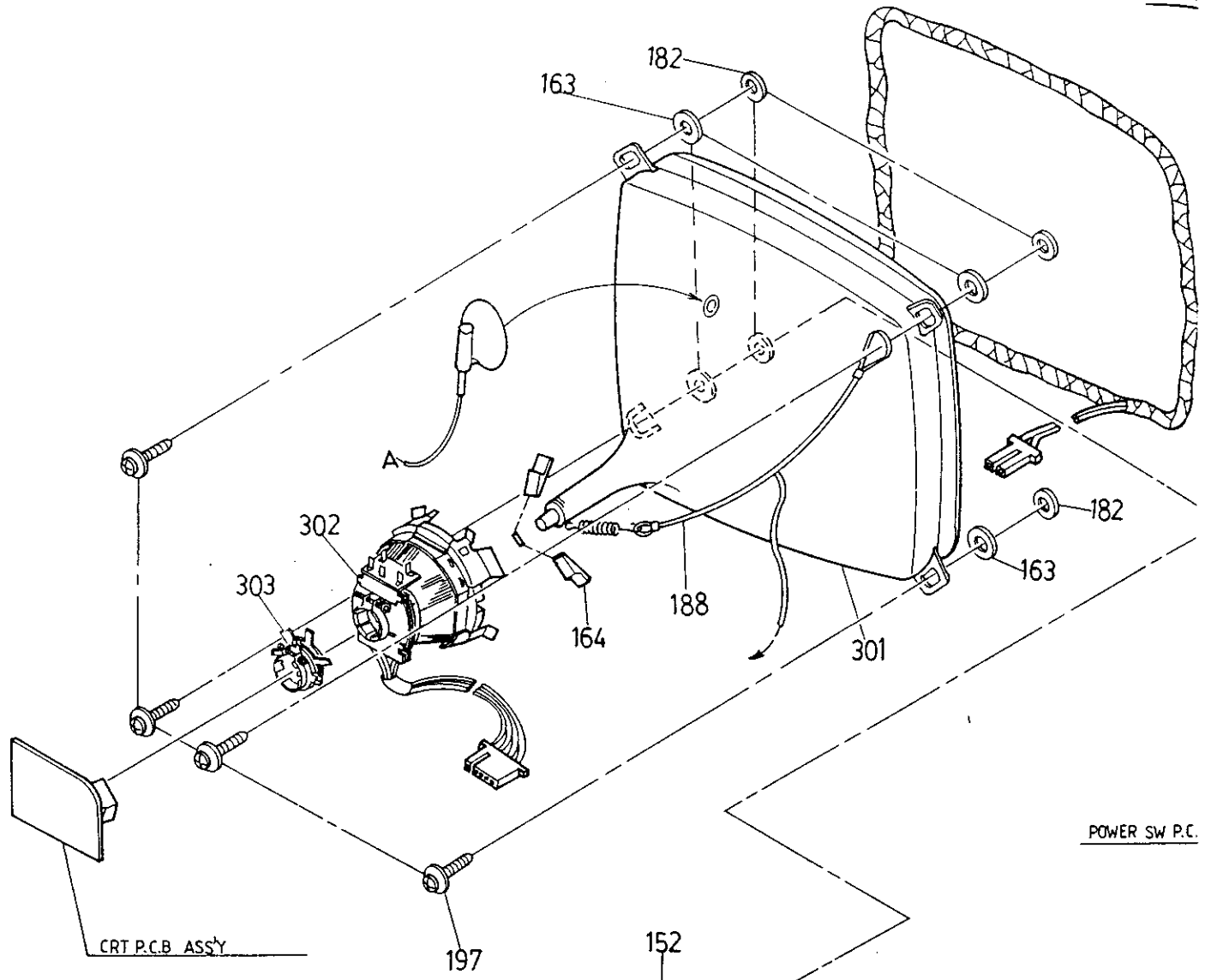

POWER SW P.C.

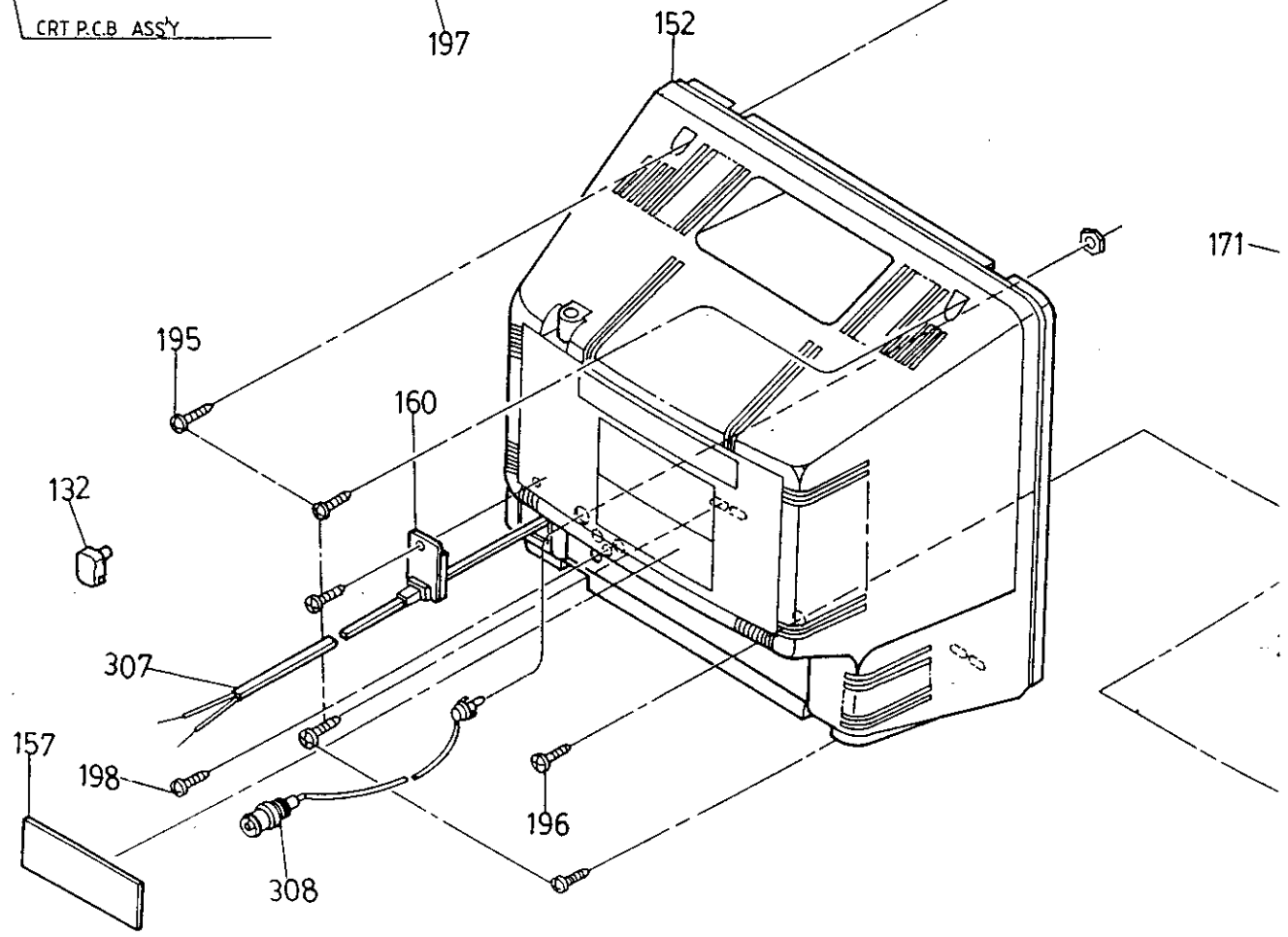

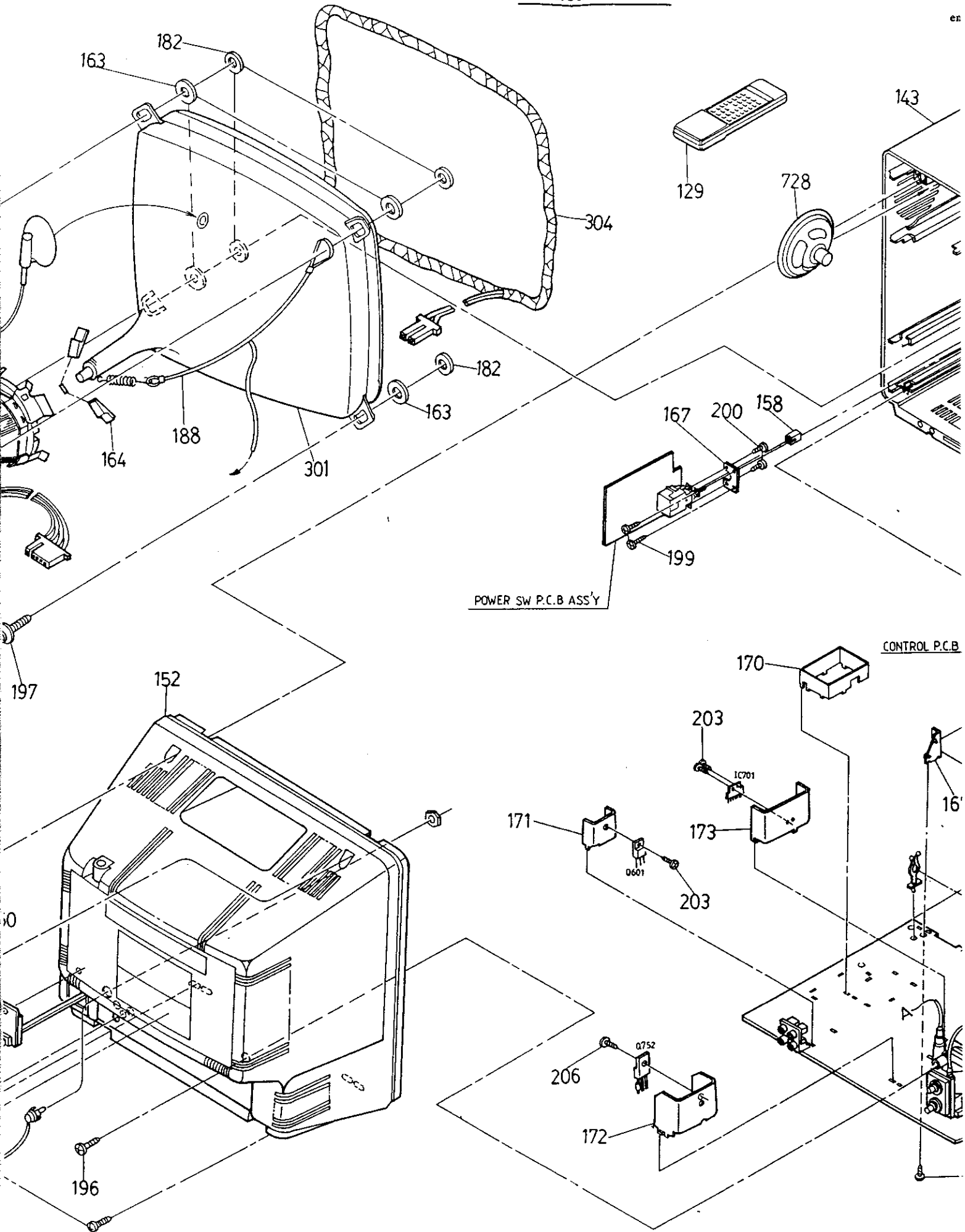

TELEVISION

EXPLODED VIEW

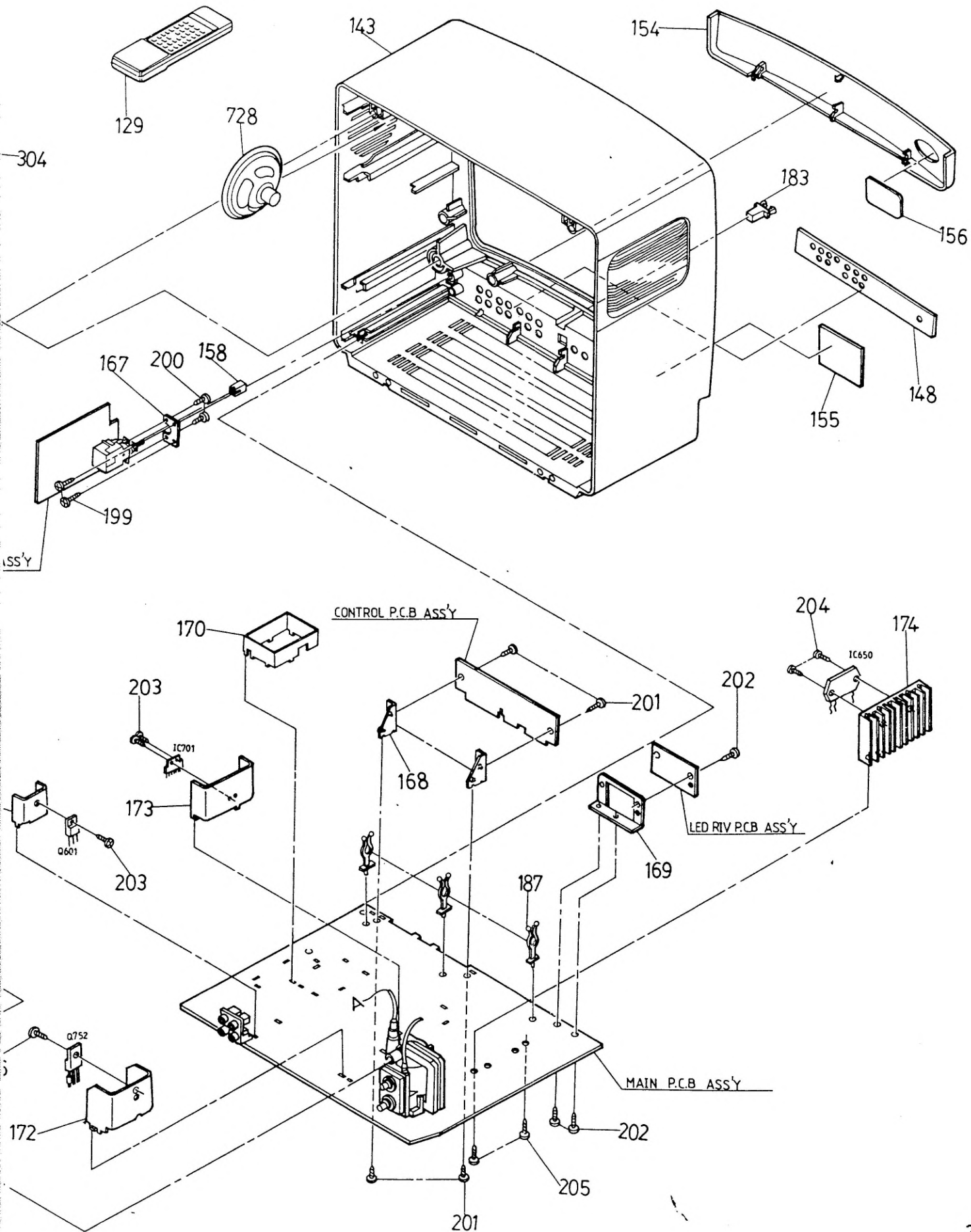

INTENTIONALLY LEFT BLANK

ONLY THE FOLLOWING PARTS ARE AVAILABLE FROM MAIN STORES

MATSUI 1436COLOUR TELEVISION

REPLACEMENT PARTS LIST

REF NO.	DESCRIPTION	PART NO.
	PCB ASSY MAIN	D5511406IA
	PCB ASSY (2324)	D5511406IB
	PCB ASSY (2325)	D5511406IC
	PCB ASSY (2326)	D5511406ID
	FRAME ANTENNA	1391015
	CABINET	1412K02601
	CABINET BACK	1422K02101
	RES FUSE	51020152R2LB
CF251	CER FILTER	56710153
CF254	CER. FILTER	56710162
DL301	DELAY LINE	5901018
DL302	DELAY LINE	5901022
D101-5	DIODE 1SS133	56361SS133
D106-7	DIODE 1S2473	56361S2473
D108-111	DIODE 1SS133	56361SS133
D112	ZENER DIODE	5635RD5R6EB1
D113	DIODE 1SS133	56361SS133
D114	DIODE 1S2473	56361S2473
D124,441	DIODE 1SS133	56361SS133
D161-164	DIODE 1SS133	56361SS133
D191	ZENER	5635RD5R1EB2
D211,231	DIODE S5566B	5632S5566B
D212	ZENER DIODE	5635RD9R1EB2
D301,2,5	DIODE 1SS133	56361SS133
D306,481	DIODE 1SS133	56361SS133

MATSUI 1436 REPLACEMENT PARTS LIST PAGE 2

REF NO.	DESCRIPTION	PART NO.
D350	ZENER DIODE	5635RD8R2EB2
D482,701	DIODE S5566B	5632S5566B
D483-4	DIODE 1SS133	56361SS133
D485	ZENER DIODE	5635RD9R1EB3
D486	DIODE 1S2473	56361S2473
D501-3	ZENER DIODE	5635RD12EB2
D601,2,6	DIODE RL104FG	5632RL104FG
D604	ZENER DIODE	5635RD12EB2
D605	DIODE 1SS133	56361SS133
D651-4	DIODE RL105	5632RL105
D665	DIODE ERD29-06	5632ERD2906
FU211	FUSE 160MAMP	5732161054
FU650	FUSE 4AMP	5732402054
IC101	M3430001	5654M3430001
IC102	M6M800AP	5654M6M800AP
IC103	MN1280M	5653MN1280M
IC104	UPC574J	5652UPC574J
IC251	TA7680AP	5653TA7680AP
IC301	TA7698AP	5652TA7698AP
IC351	TC4066BP	5654TC4066BP
IC650	STK7348	5651STK7348
IC701	AN5515	5653AN5515
IC851	AN5265	5653AN5265
J351	PIN JACK	448900104001
LED101	LED	5637LTL307P

MATSUI 1436 REPLACEMENT PARTS LIST PAGE 3

REF NO.	DESCRIPTION	PART NO.
L161	COIL	5995120J69
L162	COIL	5995101J69
L252	COIL	59952R7J69
L253	COIL	59952R2191
L254,5	COIL	59955R6J69
L256	COIL	5995150J69
L335	COIL	59958R2J69
L403	COIL	5995330J69
L501	COIL	5995221J69
L651	COIL	558350303
L652	COIL	5995330K108
L751	COIL	5995620088
Q105-7,9	TRANS 2SC1815	56131815Y
Q150	TRANS 2SA1015(Y)	56111015Y
Q151-2,	TRANS 2SC1815	56131815Y
Q161,210	TRANS 2SC1815	56131815Y
Q162-3	TRANS 2SA1015(Y)	56111015Y
Q190-1	TRANS 2SC1815	56131815Y
Q211	TRANS 2SC2120(Y)	56132120Y
Q231-2	TRANS 2SC1815	56131815Y
Q251	TRANS 2SC1923(Y)	56131923Y
Q252,302	TRANS 2SC1815	56131815Y
Q301,353	TRANS 2SA1015(Y)	56111015Y
Q351-2	TRANS 2SC1815	56131815Y
Q354-5	TRANS 2SC1815	56131815Y

MATSUI 1436 REPLACEMENT PARTS LIST PAGE 4

REF NO.	DESCRIPTION	PART NO.
Q501-3	TRANS 2SC1573A(R)	56131573A
Q601	TRANS 2SD313E	5613313E
Q751	TRANS 2SC1573A(R)	56131573A
Q752	TRANS 2SD1877	56141877
RCV101	RECEIVER BLOCK	614300801
RL650	RELAY DC	433110120124
R602,7	RES FUSE 2.2OHM 1W	51020252R2LC
R603	RES FUSE 2.2OHM 2W	51020352R2LD
SF261	SAW FILTER	5679F3901
SU501	SOCKET	4474204
S101-112	SWITCH PUSH	4431A010174
S301	SWITCH SLIDE	4421012415
S650	SWITCH PUSH	4431A027160
TH650	POSISTOR	5912S02MN180
TU101	UHF TUNER	611600101
T251	COIL	593300104
T252,3	COIL	593300103
T402	COIL	593200226
T403	COIL	593300234
T601	XFORMER FB	4992002
T650	T' FORMER MAINS	558400601
T652	T' FORMER SWITCHING	558400201
T751	T' FORMER IPT	558100164
X101	CER.OSC CSA400MG	5693CSA400MG
X301	XTAL OSC	56910044336A

MATSUI 1436 REPLACEMENT PARTS LIST PAGE 5

REF NO.	DESCRIPTION	PART NO.
129	REMOTE CONTROL	6142K00501
133	ADAPTER ANTENNA	1398K00101
154	LID	1452K00901
158	PUSH BUTTON	1662F04402
160	LID (AC CORD)	1452K01001
301	CRT	5721CT37N001
302	DEFLECTION YOKE	4993002
303	CONVERGENCE MAGNET ASSY	4291JH225
304	COIL REASE	4994006