

Service Manual

REVISION 4

COLOUR TELEVISION RECEIVER



MODEL 1420A

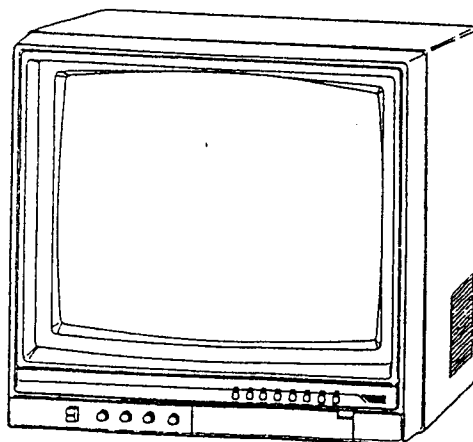

MFR'S VERSION	CRT	TUNER	POWER IC	FBI
A	S 3702B22-TC2	VST-703A	STR-451	3214002
B	S 3702B22-TC20	UE5-B51F	STR-451	3214002
C	S 3702B22-TC20	UE5-B51F	STR-50103A	3214002
D	S 3708B22-TC24	UE5-B51F	STR-50103A	3214002
E	H 370LHB22-TC11	UE5-B51F	STR-50103A	3214002
F	S 3702B22-TC20	UE5-B51F	STR-50103A	3214002
G	S 3702B22-TC20	UE33-B02	STR-50103A	3214002
H	S 3702B22-TC20	UE33-B02	STR-50103A	3214009
I	C 370KR22-TC21	UE33-B02	STR-50103A	3214009

MFR'S VERSION

Please file this Revision with Original Version.

Specifications are subject to change without notice.

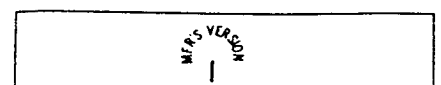

RELEASE 1 MAY 1987

COMBINED
SAISHO CT 141X
AND
MATSUI 1420A
14" PORTABLE
COLOUR TELEVISION
SERVICE MANUAL

SAISHO CT 141X AND MATSUI 1420A

14" PORTABLE COLOUR TELEVISION

C O N T E N T S

	PAGE/S
ELECTRICAL SPECIFICATIONS	1
NOTES	2
ALIGNMENT INSTRUCTIONS	3-4
MAJOR COMPONENTS LOCATION GUIDE	5
POWER SUPPLY P.C. BOARD	6
BLOCK DIAGRAM	7
MAIN P.C. BOARD	8
CHASSIS SCHEMATIC DIAGRAMS	9-10
MECHANICAL EXPLODED VIEW	11
SAISHO CT 141X REPLACEMENT PARTS LIST	13-17
NOTES	18
MATSUI 1420A REPLACEMENT PARTS LIST	19-24

SAISHO CT 141X AND MATSUI 1420A

14" PORTABLE COLOUR TELEVISION

ELECTRICAL SPECIFICATIONS

PICTURE SIZE.....14 inch (34cm "V")

SYSTEM.....PAL-UK

FREQUENCY RANGE UHF.....21 - 69 ch, 470 - 862 MHz

MAXIMUM SENSITIVITY UHF.....20 dB

INTERMEDIATE FREQUENCY:

Picture IF Carrier Frequency.....39.5 MHz

Colour Sub Carrier Frequency.....35.07 MHz

Sound IF Carrier Frequency.....33.5 MHz

SOUND INTERMEDIATE FREQUENCY.....6.0 MHz

MAXIMUM OUTPUT POWER.....1.3 W

10% THD OUTPUT POWER.....1.0 W

SPEAKER.....8 ohm

POWER SOURCE.....AC 240V

IMPORTANT

FOR SERVICE WORK ALWAYS USE MAINS ISOLATING TRANSFORMER, CHASSIS IF LIVE.

(IRRESPECTIVE OF POLARITY OF MAINS PLUG.)

SAISHO CT 141X AND MATSUI 1420A

14" PORTABLE COLOUR TELEVISION

N O T E S

ALIGNMENT INSTRUCTIONS

SHUT DOWN CIRCUIT

When the high voltage rises, a simultaneous voltage increase will develop at terminal 9 of the Horizontal Output Transformer (FB401), and be applied to pin 26 of IC401. If excessive high voltage is produced, the increased voltage developed exceeds the rating of zener diode D404 causing the Horizontal Oscillator to stop functioning and the high voltage system is then shut down.

VERTICAL SIZE ADJUSTMENT

Adjust the control (VR401) so that the picture fills the picture opening from top to bottom and is proportionate to the width.

RF AGC ADJUSTMENT

The RF AGC control is adjusted at the factory and rarely requires re-adjustment unless the received picture exhibits too much snow or the receiver lacks sensitivity. Home adjustment can be made by tuning in a weak snowy station and adjusting RF AGC for the least amount of snow. For a more accurate adjustment use the following procedure.

1. Receive the signal of test pattern (80dB).
2. Adjust AGC pin of IV tuner (IP29) to 4.65V with VR201 control.

FOCUS ADJUSTMENT

Adjust focus control, on the flyback transformer, for fine picture.

SUB BRIGHT ADJUSTMENT

1. Receive the signal of Monochrome pattern.
2. Set the Contrast (VR102-4) control to maximum position.
3. Set the Brightness (VR102-3) control to minimum position.
4. Adjust the Sub Bright (VR605) control to obtain a dim white pattern on 75% of gray scale.

HUE DELAY ADJUSTMENT

1. Receive the signal of DEM pattern.
2. Connect dual oscilloscope to Q801 and Q803 of the base.
3. Set the color (VR102-2) control to maximum position.
4. Adjust waveform to straight line with VR604, VR603 and L604.

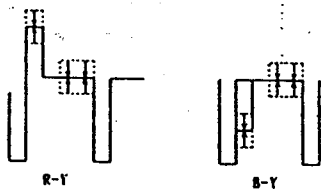

COLOR PURITY ADJUSTMENT

The receiver must have been operating 10 minutes prior to this procedure and the face plate of the CRT must be at room temperature. The following procedure is recommended while using a Dot/Bar Generator.

1. Check for correct location of all neck components. (Refer to Figure 1)
2. Rough-in the static convergence at the center of the CRT, as explained in the static convergence.
3. Rotate the contrast control to maximum CCW position and rotate brightness control as far CW as possible without causing the picture to "bloom".
4. Rotate the Red (VR801) and Blue (VR804) Cut off controls to maximum CCW position to produce a green raster.
5. Loosen the deflection yoke clamp screw and pull the deflection yoke toward the rear of the CRT.

6. Begin the following adjustment with the tabs on the round purity magnet rings set together, slowly separate the two tabs while at the same time rotating them to adjust for a uniform green stripe at the center of the CRT screen.
7. Carefully slide the deflection yoke forward to achieve green (uniform green screen).
NOTE: Center purity is obtained by adjusting the tabs on the round purity magnet rings, outer edge purity is obtained by sliding the deflection yoke forward.
8. Check for red and blue field purity by alternately increasing output of Red (VR801) and Blue (VR804) Cut off controls and touch up adjustments, if required.
9. Tighten deflection yoke clamp screw.

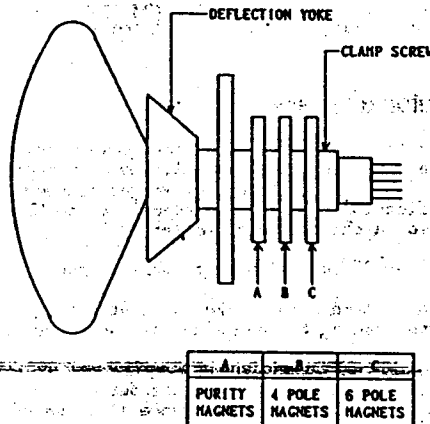

Figure 1. Picture Tube Neck Component Location

BLACK AND WHITE TRACKING

The purpose of this procedure is to adjust the biases applied to the picture tube to obtain good black and white picture production at all brightness levels while, at the same time achieving maximum useable brightness. Proper RF AGC control adjustment should have been verified prior to performing this procedure.

1. With antenna connected to the receiver, tune in picture on a strong received channel. Misadjust the fine tuning control so that receiver will not produce a color picture while the following adjustments are being performed.
2. Rotate the Red (VR802) and Blue (VR805) Drive control fully CW and then back CCW to the center of their rotation ranges.
3. Rotate the Red (VR801) and Blue (VR804) Cut off controls to the fully CCW end of their rotation ranges.
4. Set normal-service switch to service position. Adjust the voltage of test point (collector of green output transistor on CRT PCB) to DCL20V with brightness control. Voltage measurement should be measured with an oscilloscope.
5. Rotate the screen control to the fully CCW end of its rotation range. Then, rotate it CW until a dim line of one pronounced color (green, red or blue) is obtained.
6. The other two color Cut off controls must be rotated CW until a dim white line is obtained.
7. Set normal-service switch to normal position.
8. If required, touch-up adjustment of the Red (VR802) and Blue (VR805) Drive controls to produce a uniform monochrome picture.
9. Rotate the brightness and contrast controls fully CCW.
10. Rotate the brightness control CW until a dim raster is obtained.
11. If the screen does not display with uniformity, steps 2 through 10 of this procedure must be repeated.

14" PORTABLE COLOUR TELEVISION

ALIGNMENT INSTRUCTIONS

STATIC CONVERGENCE ADJUSTMENT

1. Switch the Receiver ON and allow it to warm up for 15 minutes.
2. Connect the output of a Crosshatch Generator to the receiver and, concentrating on the center of the CRT screen, proceed as follows:
 - a. Locate a pair of 4 pole magnet rings. Rotate individual rings (change spacing between tabs) to converge the vertical red and blue lines. Rotate a pair of rings (maintaining spacing between tabs) to converge the horizontal red and blue lines.
 - b. After completing red and blue center convergence, locate the pair of 6 pole magnet rings. Rotate individual rings (change spacing between tabs) to converge the vertical red and blue (magenta) and green lines. Rotate a pair of rings (maintaining spacing between tabs) to converge the horizontal red and blue (magenta) and green lines.

DYNAMIC CONVERGENCE ADJUSTMENT

Dynamic convergence (convergence of the three color fields at the edges of the CRT screen) is accomplished by proper insertion and positioning of three rubber wedges between the edge of the deflection yoke and the tunnel of the CRT. This is accomplished in the following manner.

1. Switch the Receiver ON and allow it to warm up for 15 minutes.
2. Apply crosshatch pattern from Dot/Bar Generator to receiver. Observe spacing between lines around edges of CRT screen.
3. Tilt the deflection yoke up or down, and insert tilt adjustment wedges (1) and (2) between the deflection yoke and the CRT until the mis-convergence illustrated in Figure 2 (A) has been corrected.
4. Tilt the deflection yoke right and left, and insert tilt adjustment wedge (3) between the deflection yoke and the CRT until the mis-convergence illustrated in Figure 2 (B) has been corrected.
5. Alternately change spacing between, and depth of insertion of the three wedges proper dynamic convergence is obtained.
6. Use a strong adhesive tape to firmly secure each of the three wedges to the funnel of the CRT.
7. Check purity and readjust, if necessary.

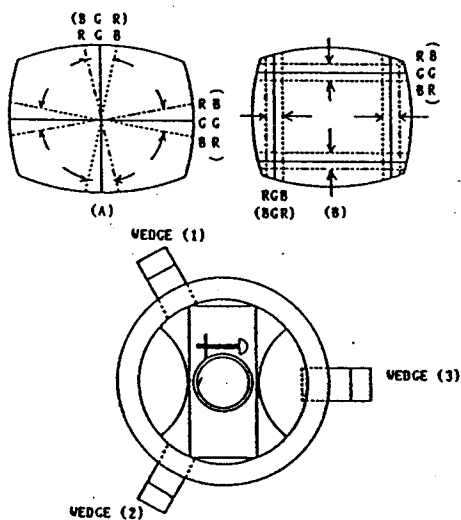

Figure 2 Dynamic Convergence Adjustment

VIDEO IF ALIGNMENT

(Refer to Figure 3)
 TEST EQUIPMENT CONNECTION
 OSCILLOSCOPE Set AC-DC switch to AC position.
 SWEEP-MARKER GENERATOR Connect H SCOPE and V SCOPE output cable from SWEEP-MARKER GENERATOR to H and V input connectors on the OSCILLOSCOPE, connect hot lead of SWEEP-MARKER OUTPUT cable to test point TP21 on PCB001; connect ground lead to chassis ground. Connect pick up SWEEP-MARKER INPUT cable to TP27; ground lead to chassis ground.

1. Connect 10K ohm variable resistor between IP24, +B(12V) to ground. Install AGC VR to prevent saturation in waveform, then adjust AGC VR for proper size of waveform. On the other hand, in case IF AGC voltage is supplied externally, adjust for proper size of waveform on condition that IF AGC voltage is within 10V and is gradually decreased.
2. Adjust L204 to obtain maximum amplitude of response curve at 39.5 MHz. (Refer to Response Curve "A")
3. Connect a 100 ohm resistor between IP22 and IP23. Re-connect hot lead of SWEEP-MARKER GENERATOR OUTPUT cable from IP21 to TV tuner IP.
4. Adjust IFT on TV Tuner obtain maximum amplitude of response curve. (Refer to Response Curve "B")
5. Disconnect the 10K ohm variable resistor and 100 ohm resistor from the circuit. Disconnect CO06. (solder bridge)
6. Connect SWEEP-MARKER GENERATOR INPUT cable from IP27 to IP26.
7. Adjust L203 to place 39.5 MHz marker at reference line on response curve. (Refer to Response Curve "C")
8. Re-connect CO06. (solder bridge)

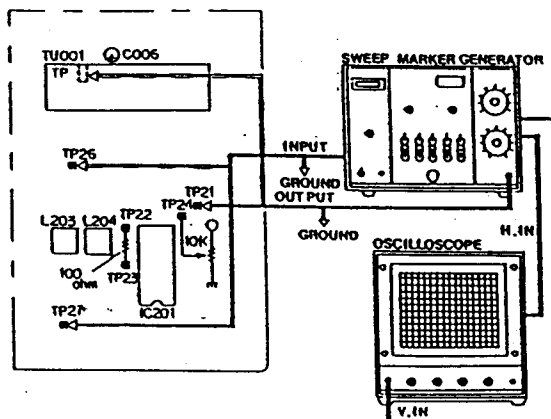
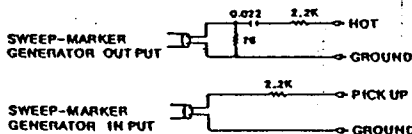
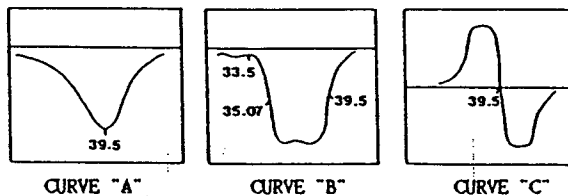
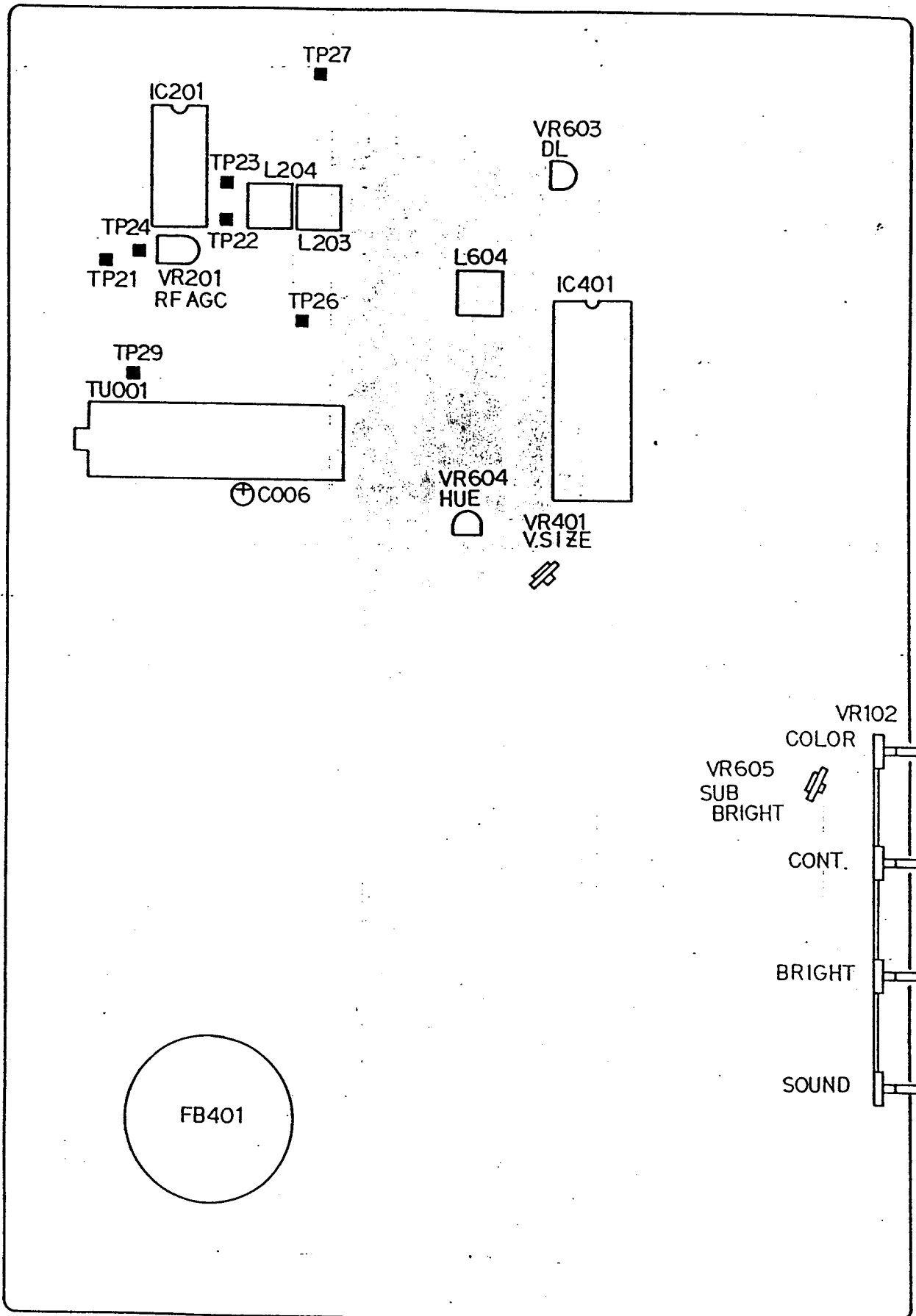

FIGURE 3

14" PORTABLE COLOUR TELEVISION

MAJOR COMPONENTS LOCATION GUIDE



SAISHO CT 141X AND MATSUI 1420A

14" PORTABLE COLOUR TELEVISION

POWER SUPPLY P.C. BOARD

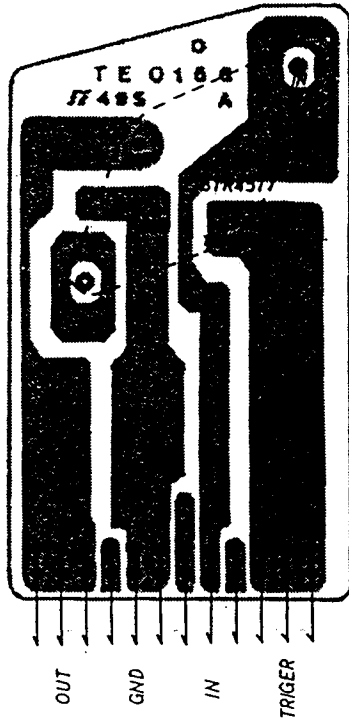

SYMBOL LIST

RESISTOR	
SEMI-FIXED RESISTOR	
CAPACITOR	
JUMPER	

BLOCK DIAGRAM

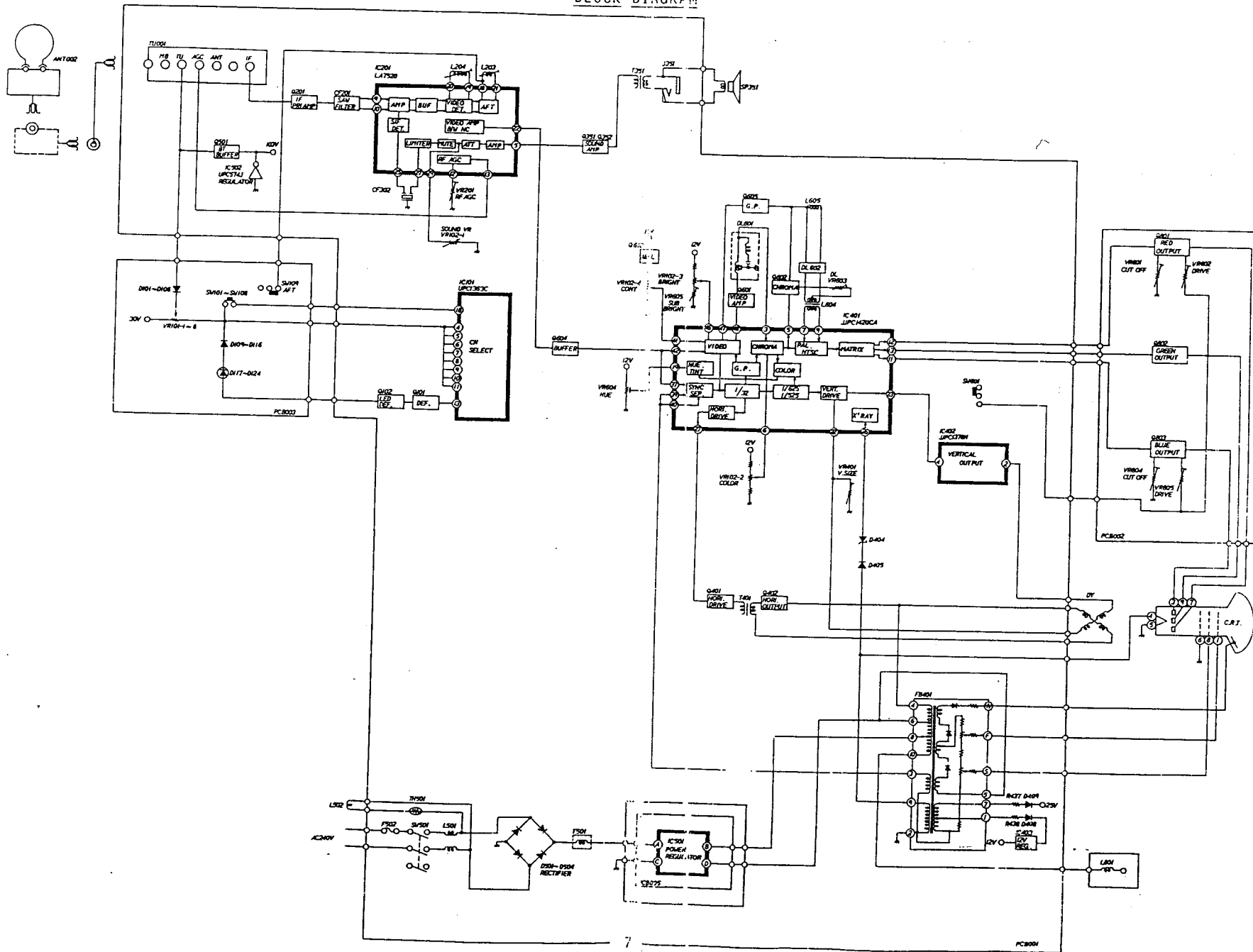

SAISHO CT 141X AND MATSUI 1420A

14" PORTABLE COLOUR TELEVISION

MAIN P.C. BOARD

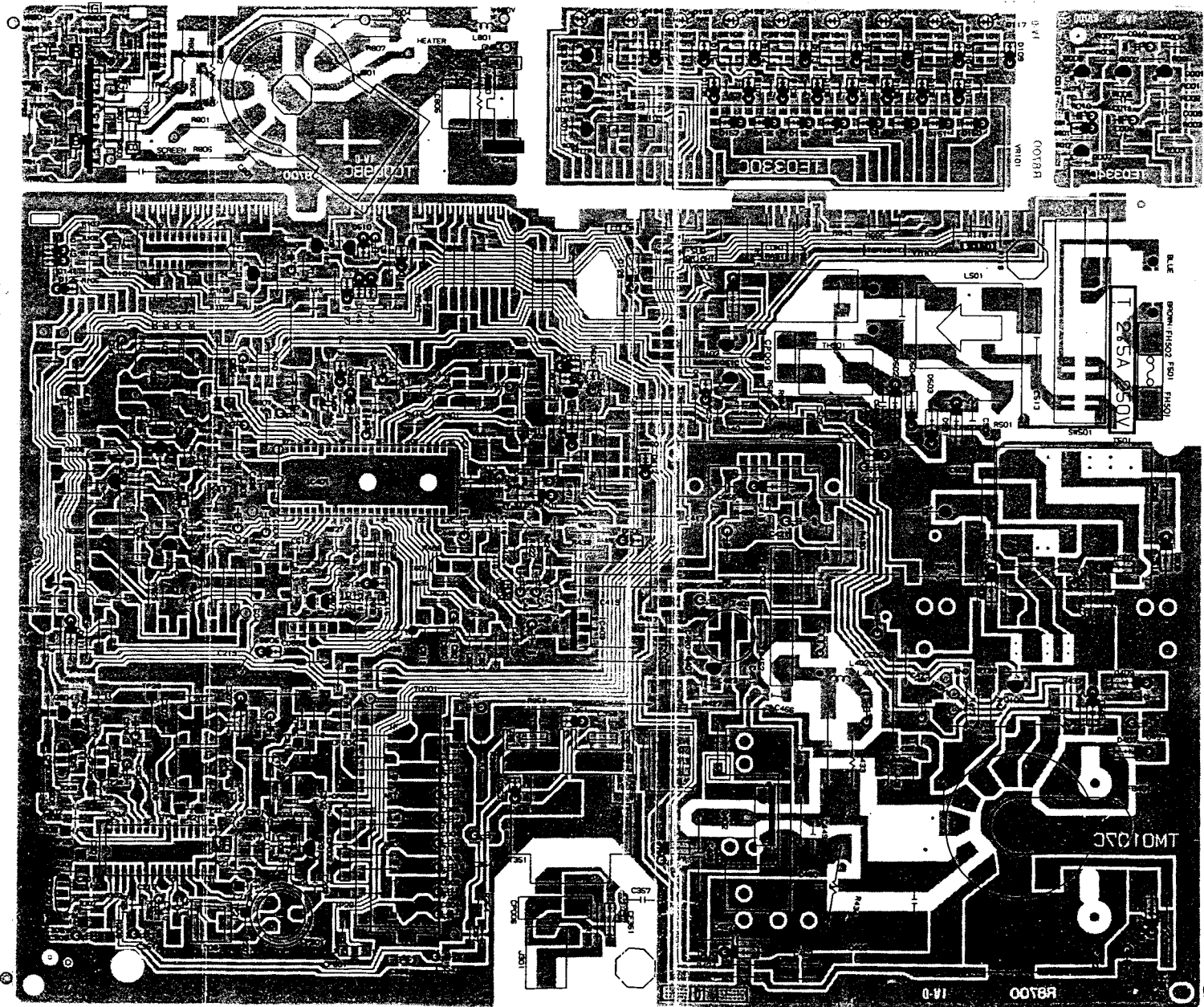

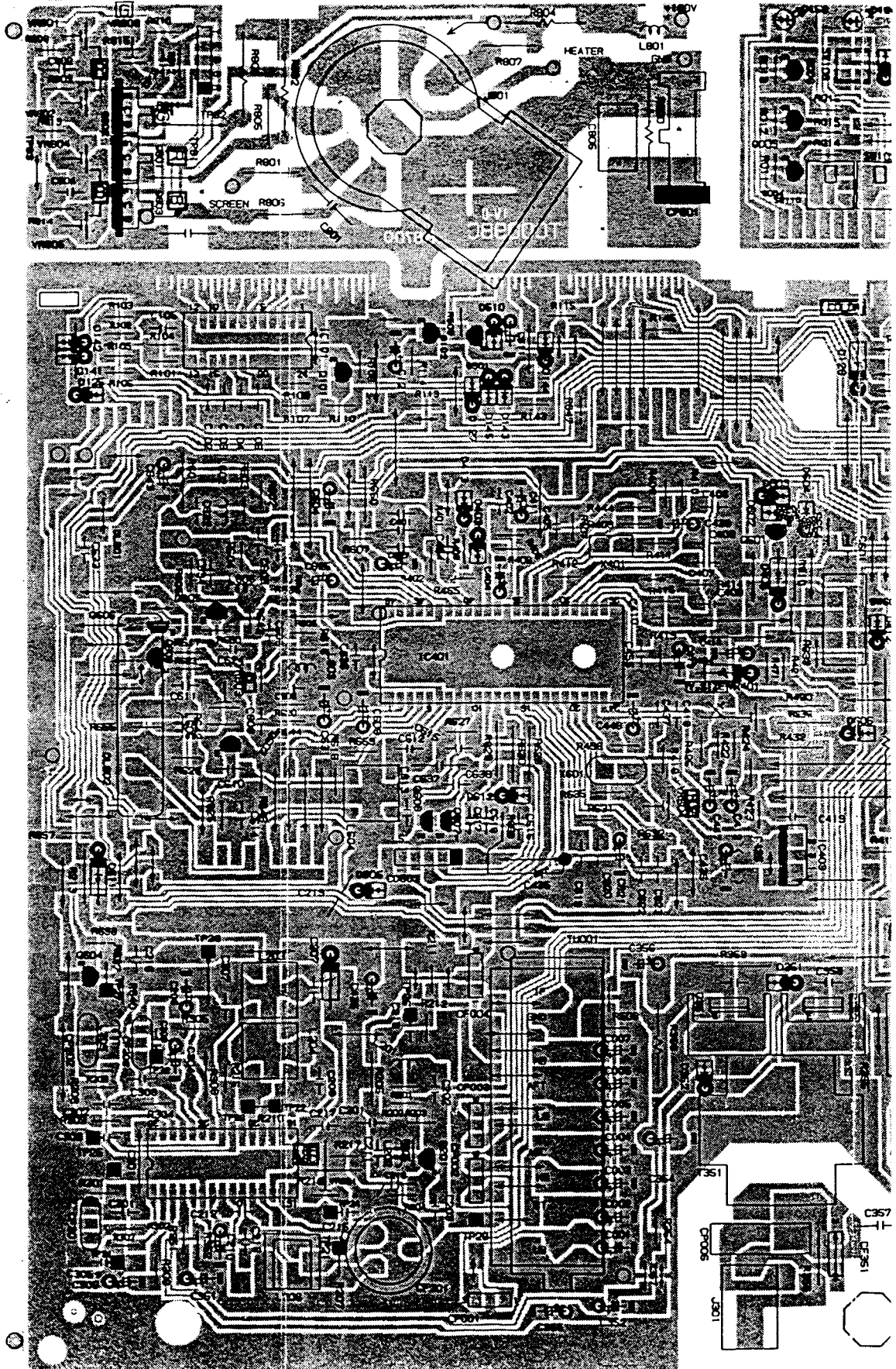

SAISHO CT 141X AND MATSUI 1420A

14" PORTABLE COLOUR TELEVISION

MAIN P.C. BOARD

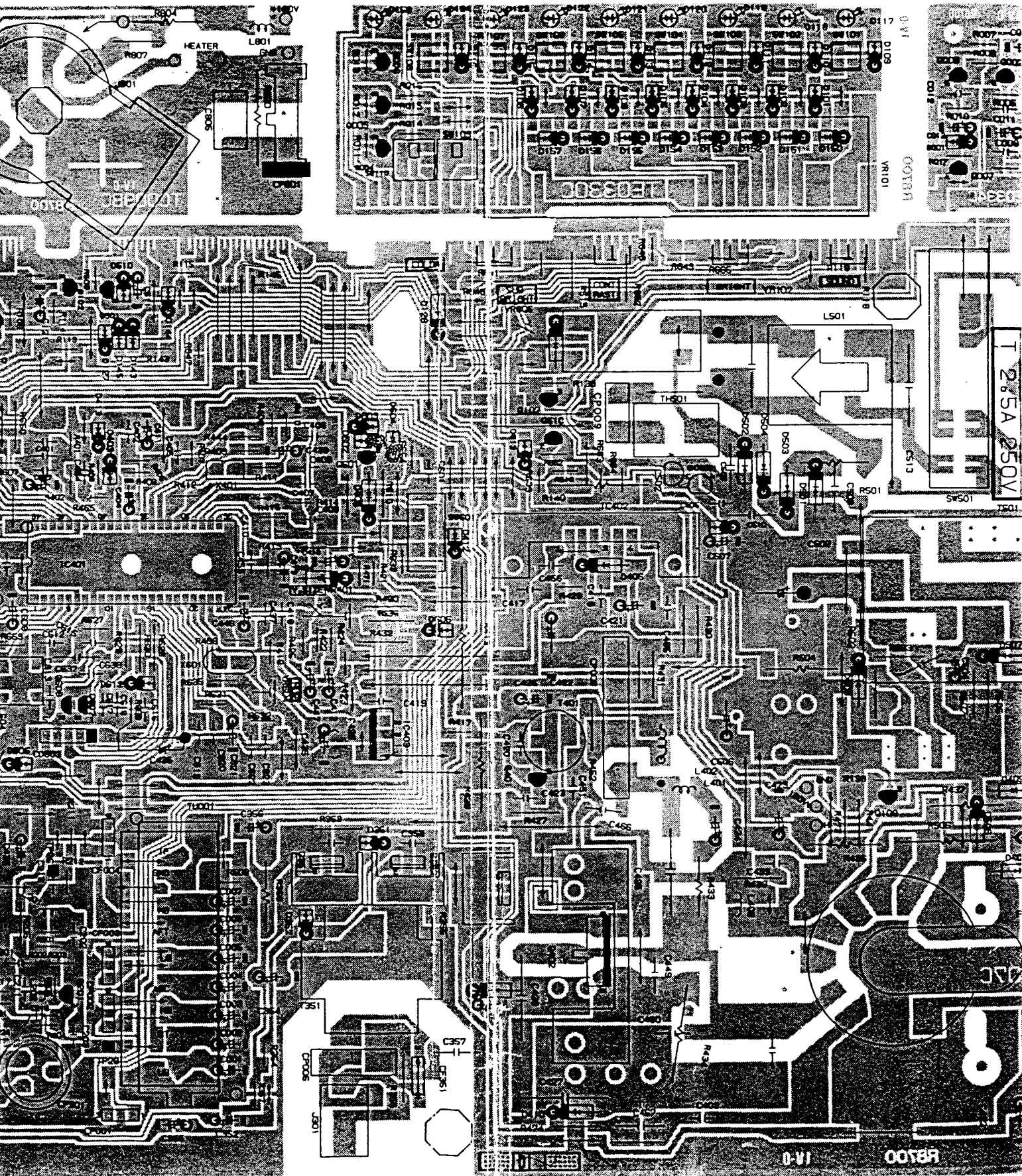

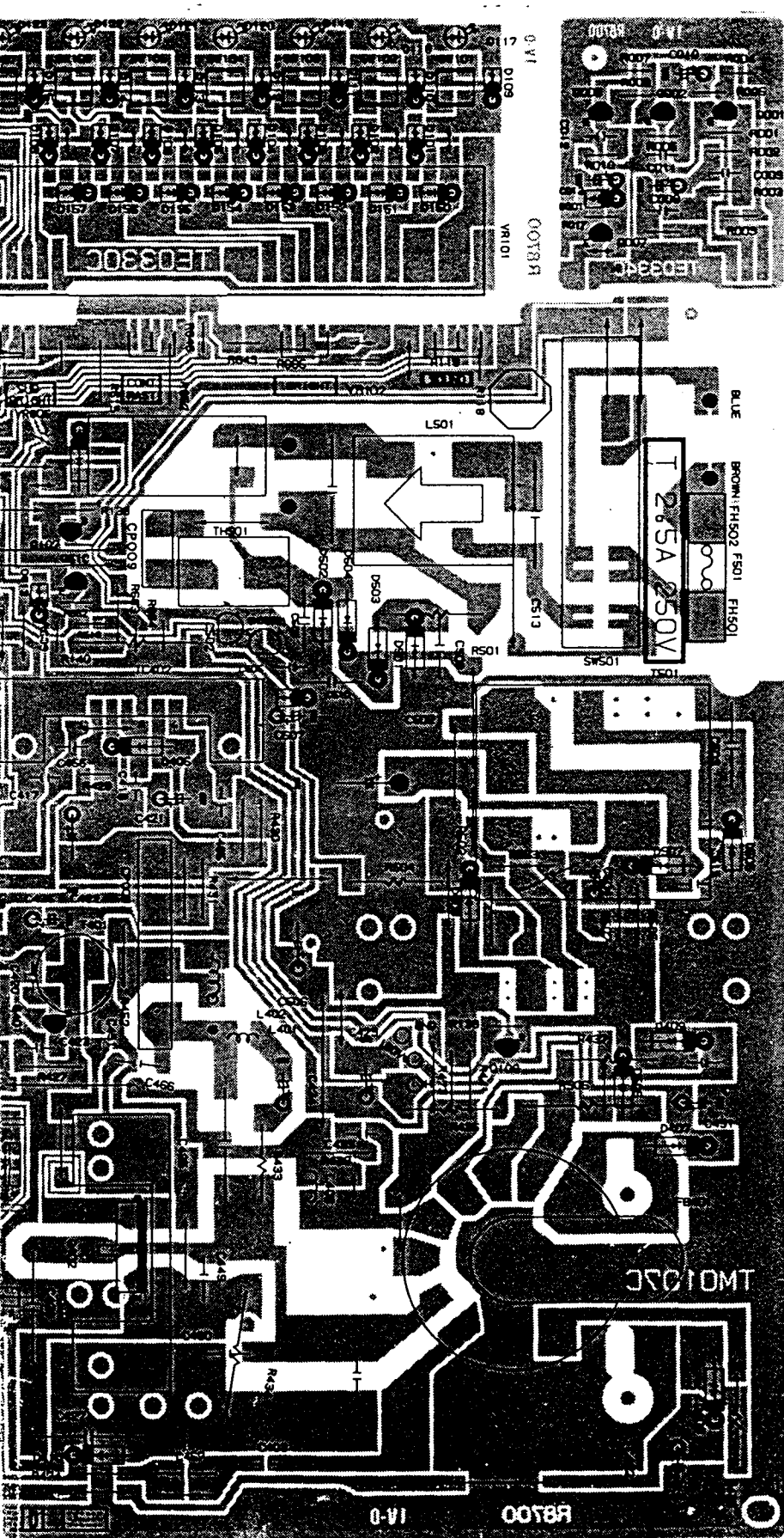

MAIN/CRT/POTENTIOMETER P.C.BOARD

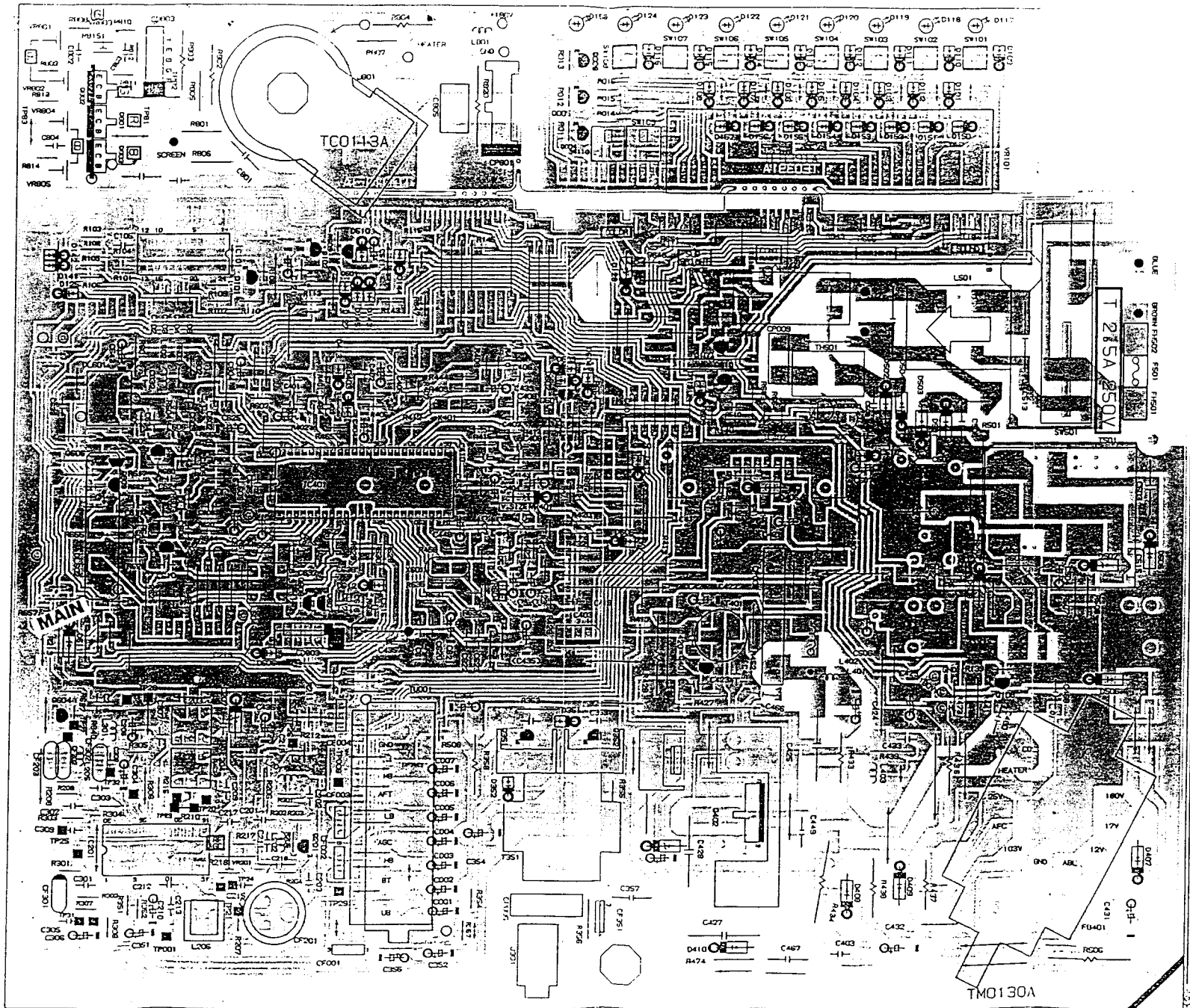

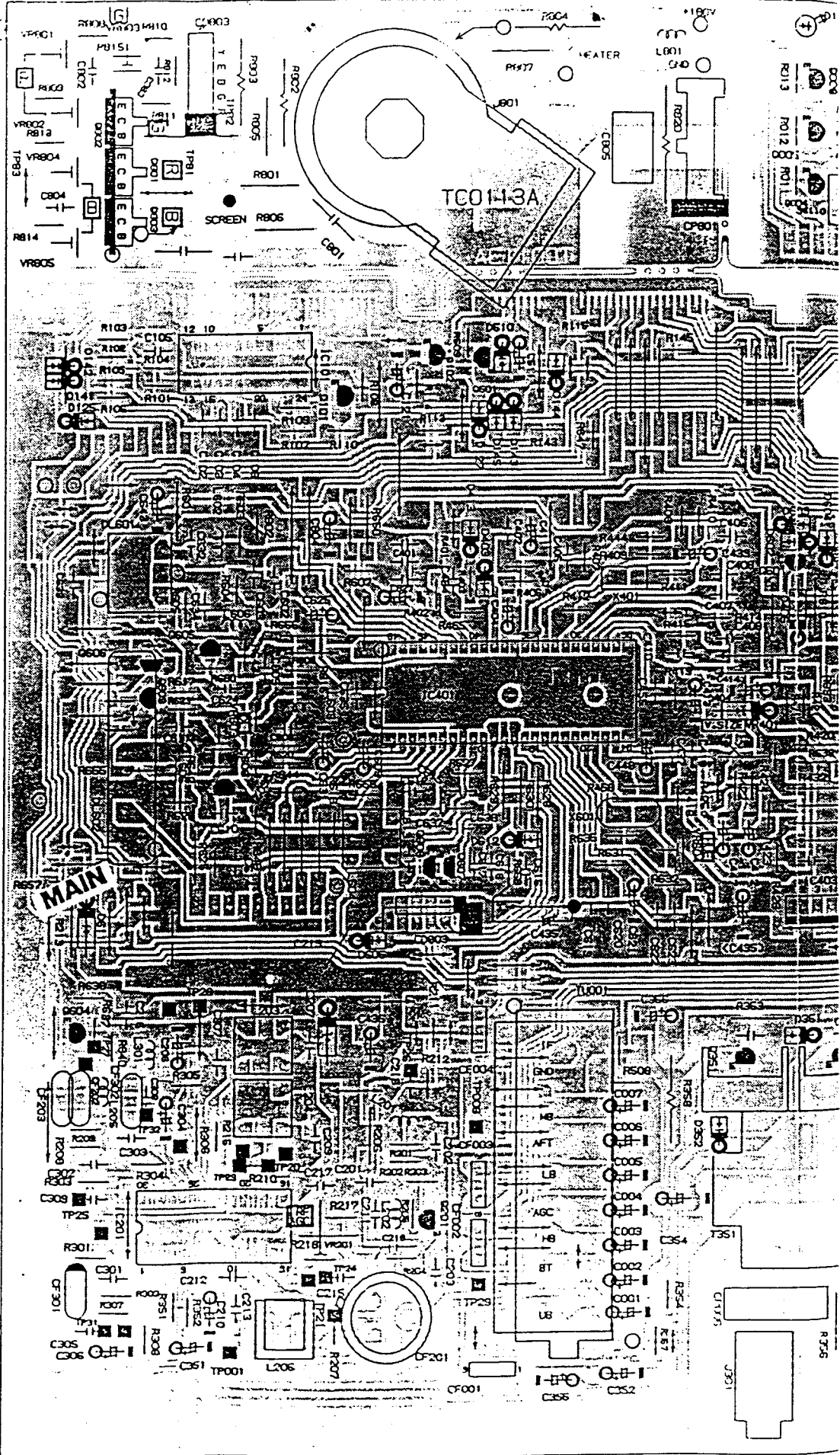

MAIN/CRT/POTENTIOMETER P.C.BOARD

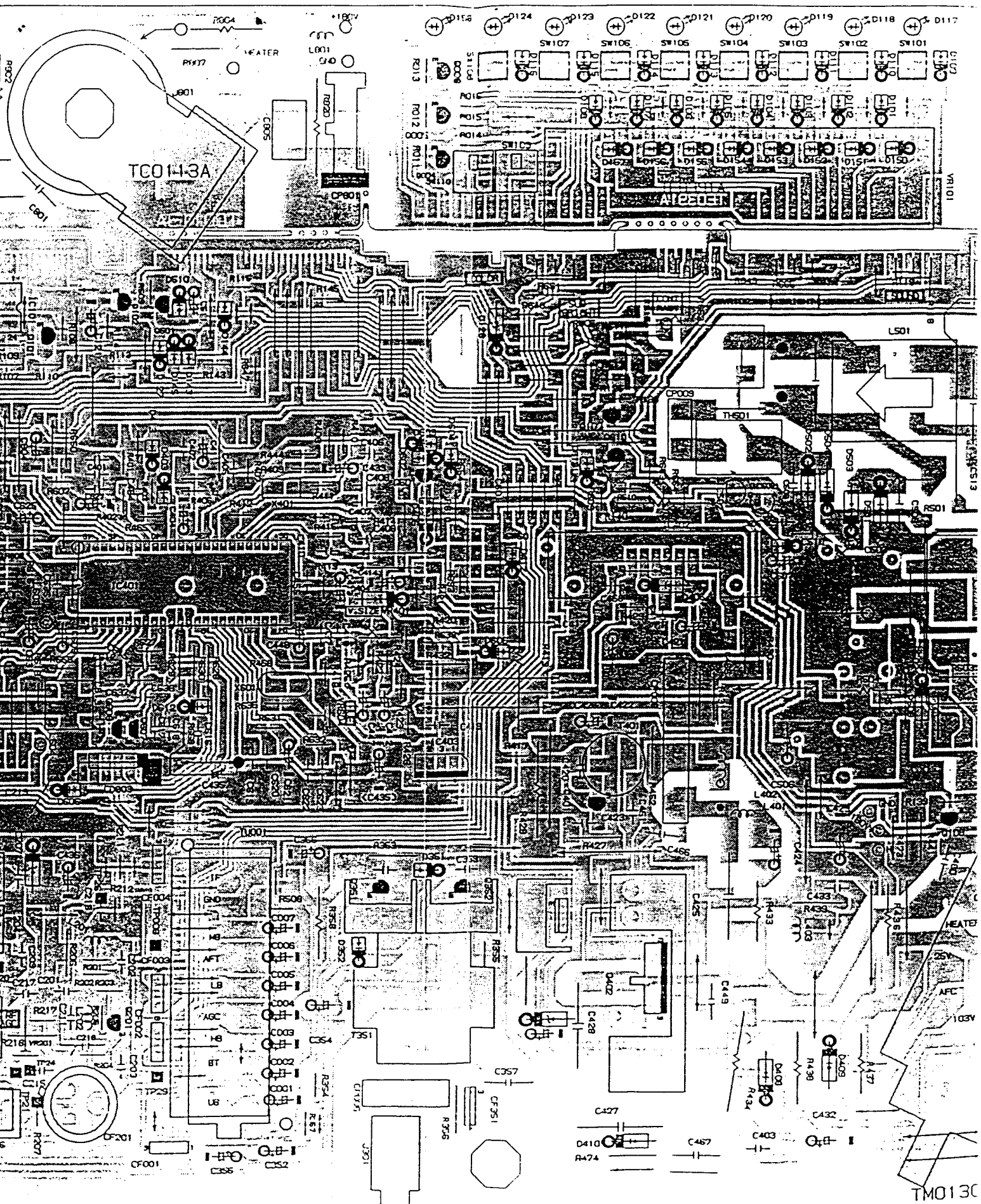

TM0130

METER P.C. BOARD

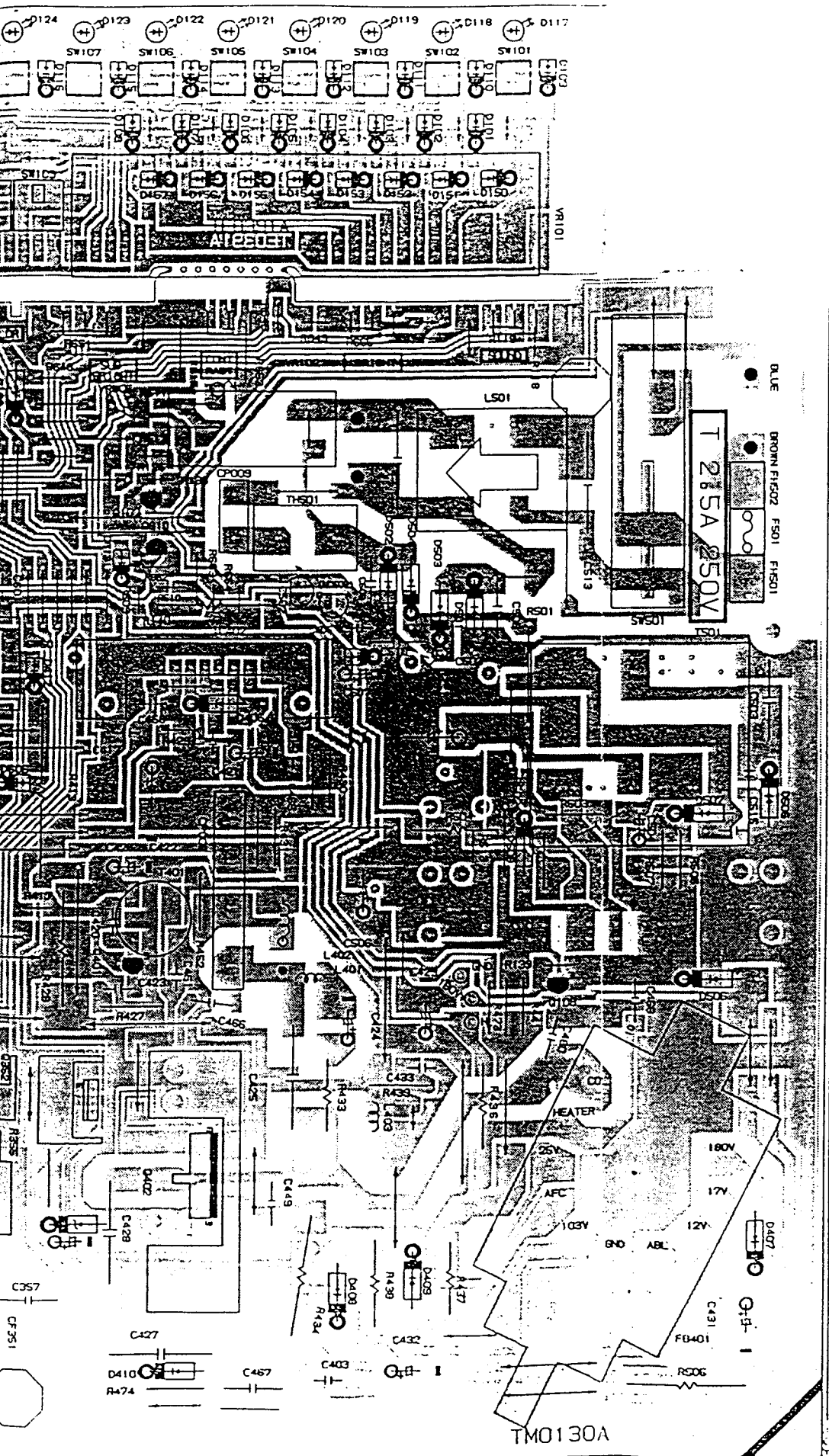

CHASSIS SCHEMATIC DIAGRAM

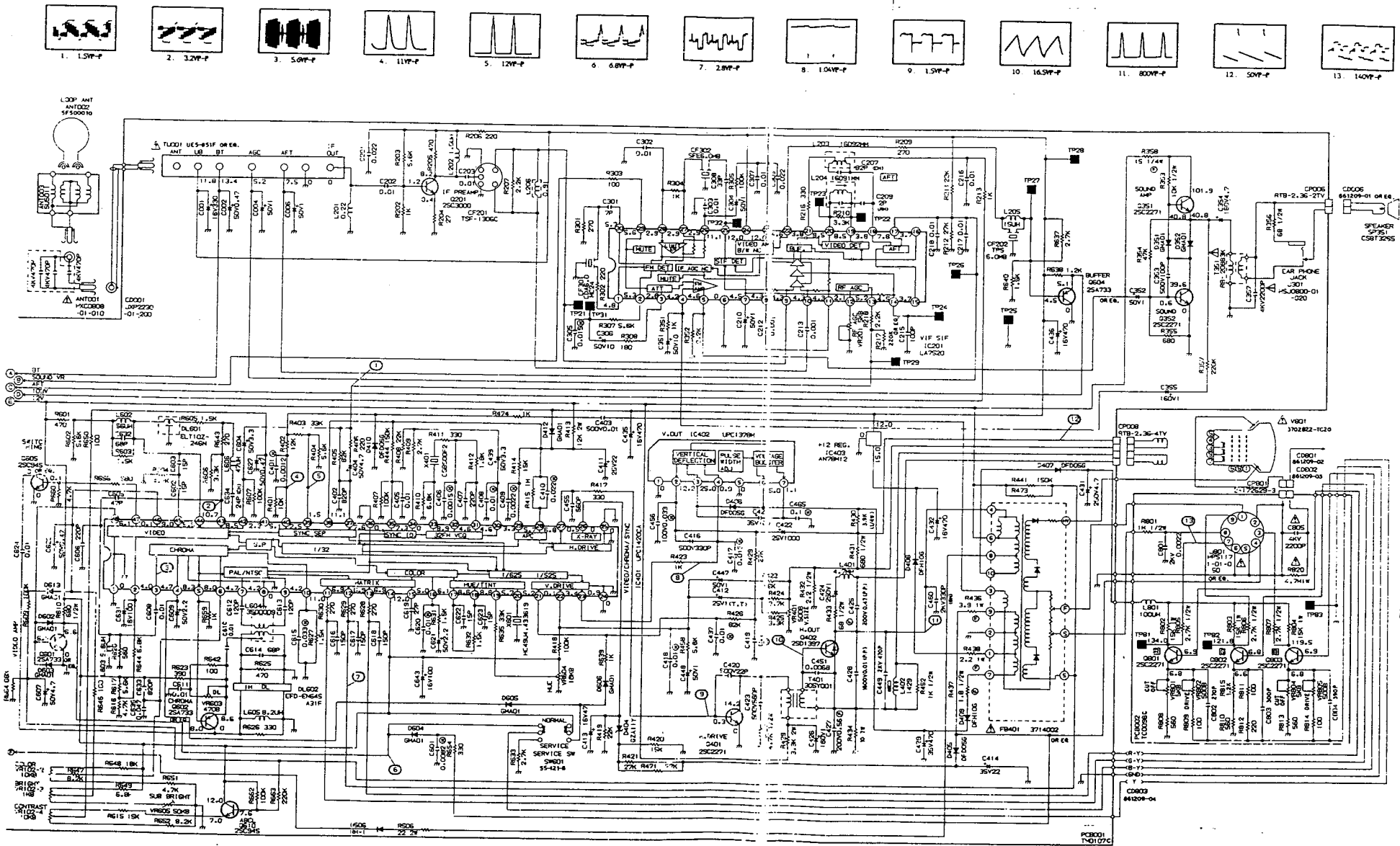

NOTE: THIS SCHEMATIC DIAGRAM IS THE LATEST AT THE TIME OF PRINTING AND SUBJECT TO CHANGE WITHOUT NOTICE.

ATTENTION: LES REPARATIONS PAR UN TECHNICIEN QUALIFIE SONT REQUISES EN VUE DE SECURITE. NE PAS REPARER LES PARTIES MARQUEES EN TRIANGLE. NE PAS REPARER LES PARTIES MARQUEES EN TRIANGLE. NE PAS REPARER LES PARTIES MARQUEES EN TRIANGLE.

CAUTION: SINCE THESE PARTS MARKED BY Δ ARE CRITICAL FOR SAFETY, USE ONLY THOSE DESCRIBED ON PARTS LIST ONLY.

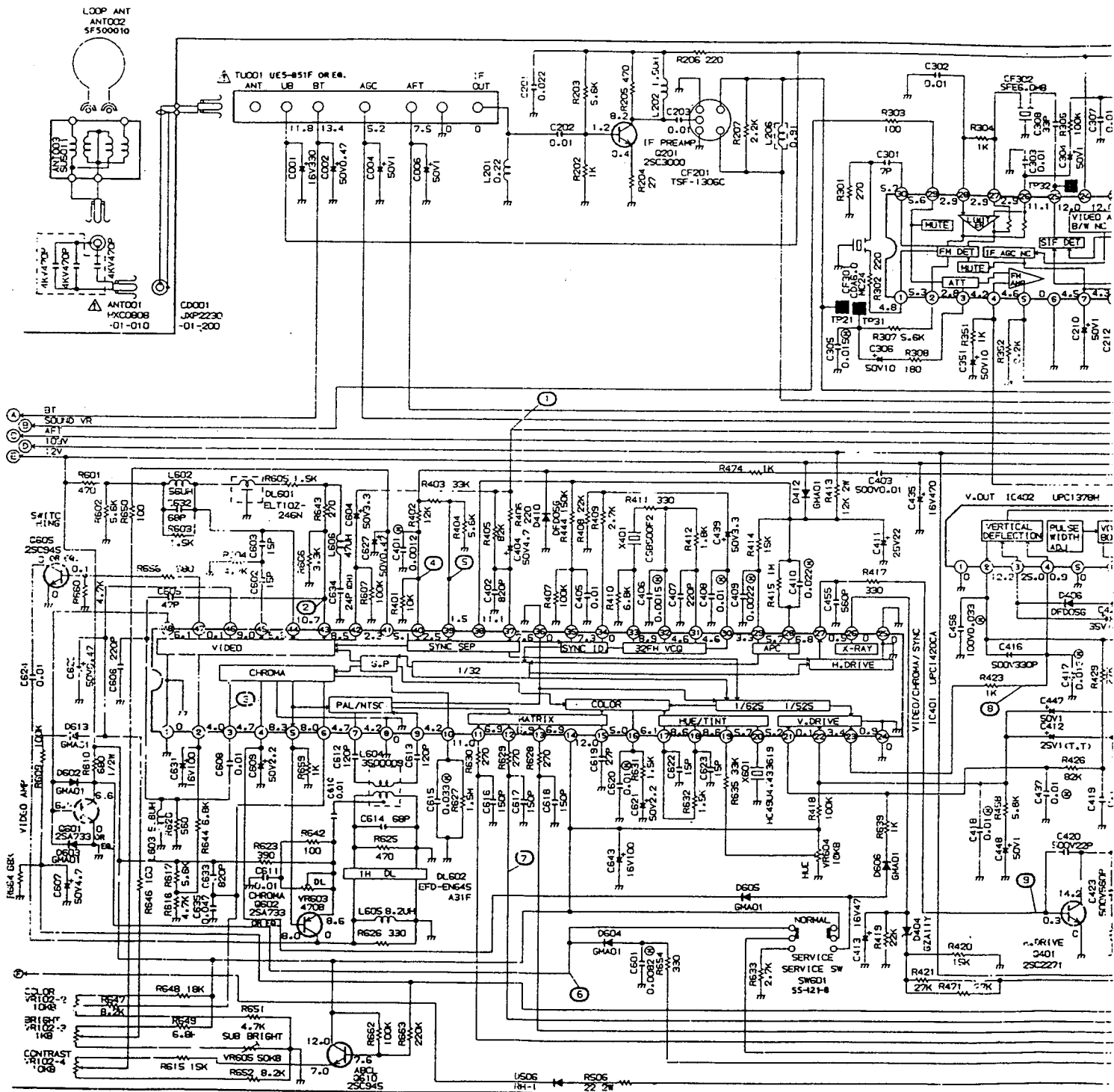
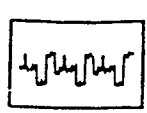
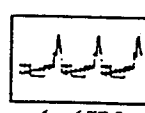
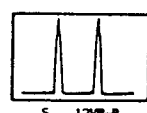
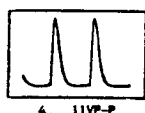
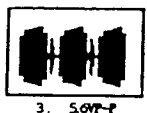
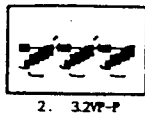
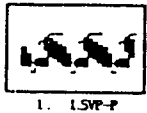

NOTE: THIS SCHEMATIC DIAGRAM IS THE LATEST AT THE TIME OF PRINTING AND SUBJECT TO CHANGE WITHOUT NOTICE.

ATTENTION: LES P. D'ANES. N'UT. D'ANS.

SAISHO CT 141X AND MATSUI 1420A

14" PORTABLE COLOUR TELEVISION

CHASSIS SCHEMATIC DIAGRAM

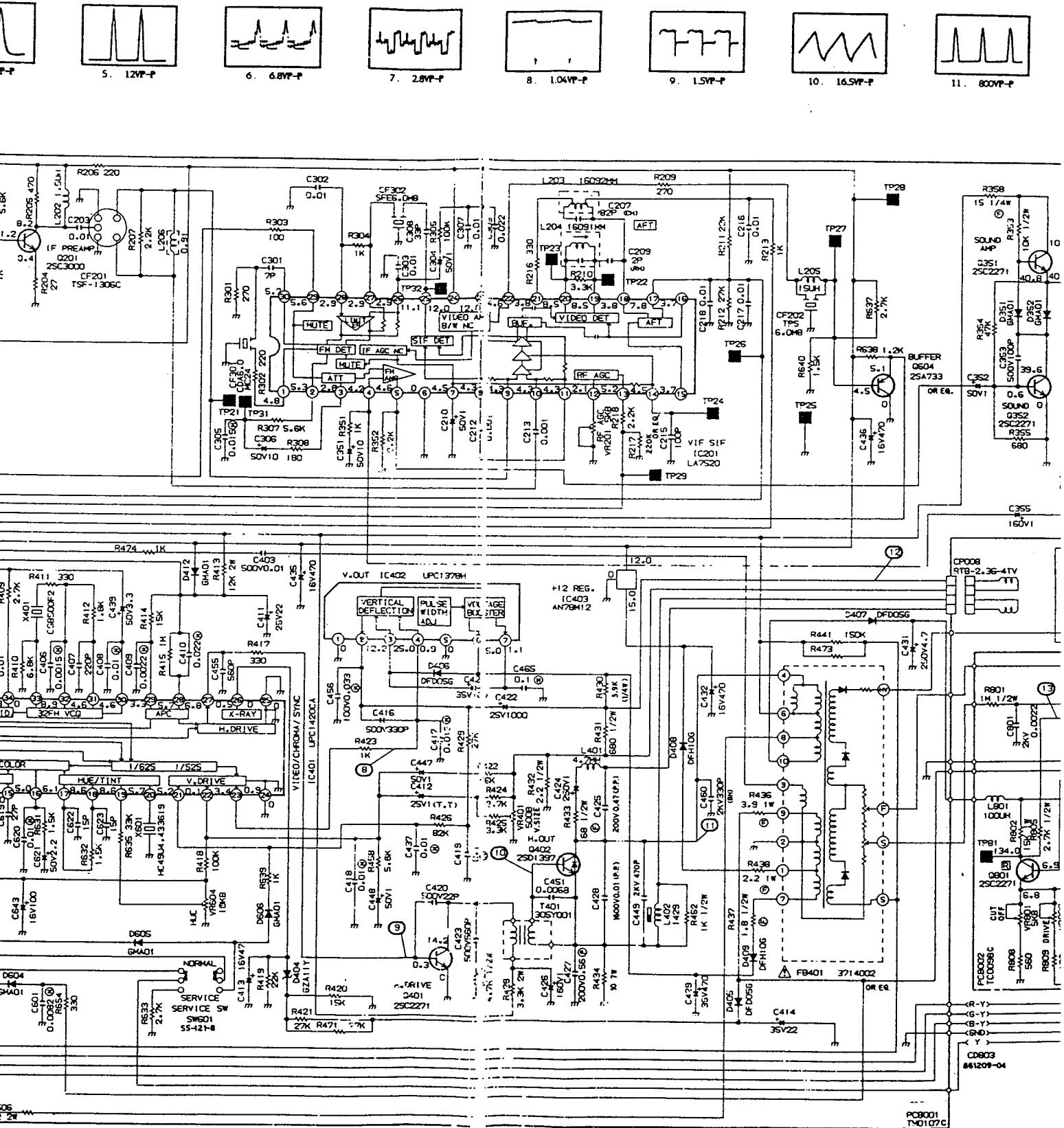

NOTE: THIS SCHEMATIC DIAGRAM IS THE LATEST AT THE TIME OF PRINTING AND SUBJECT TO CHANGE WITHOUT NOTICE.

ATTENTION: LES PARTIES REPAREES PAR UN ETANT DANGER, USES AN POINT DE VUE SECURITE N'UTILISER QUE CELLES DECRITES DANS LA NOMENCLATURE DES PIECES.

CAUTION: SINCE THESE PARTS MARKED BY ARE CRITICAL FOR SAFETY, USE ONES DESCRIBED ON PARTS LIST ONLY.

DIAGRAM

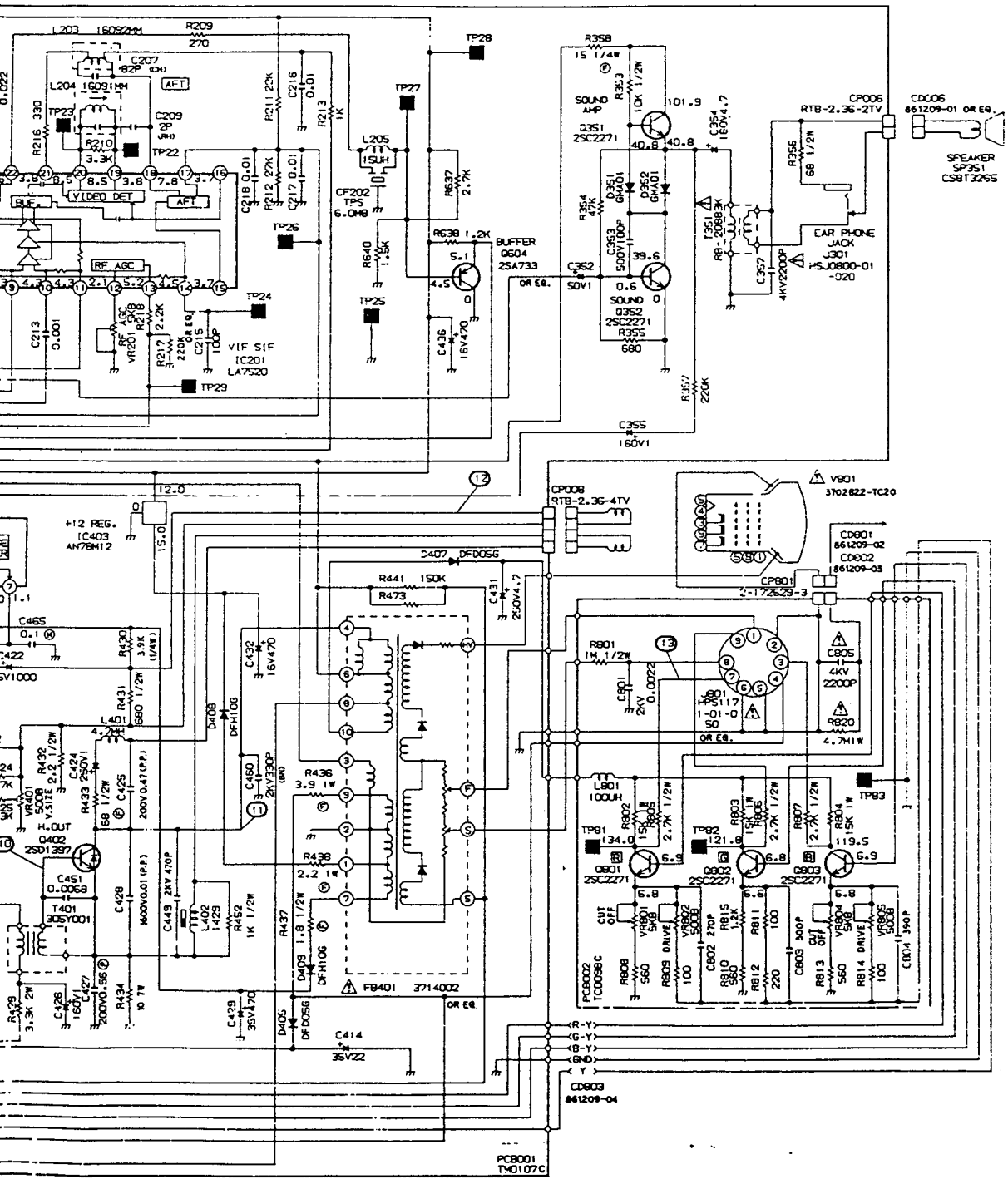
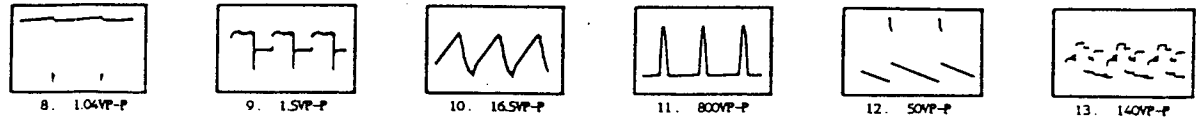

REPARÉES PAR UN ETANT
UN POINT DE VUE SECURITE.
QUE CELLES DECRIES
DANS LE MANUEL DES PIECES.

CAUTION: SINCE THESE PARTS MARKED BY ARE
CRITICAL FOR SAFETY, USE ONES
DESCRIBED ON PARTS LIST ONLY.

BLOCK DIAGRAM

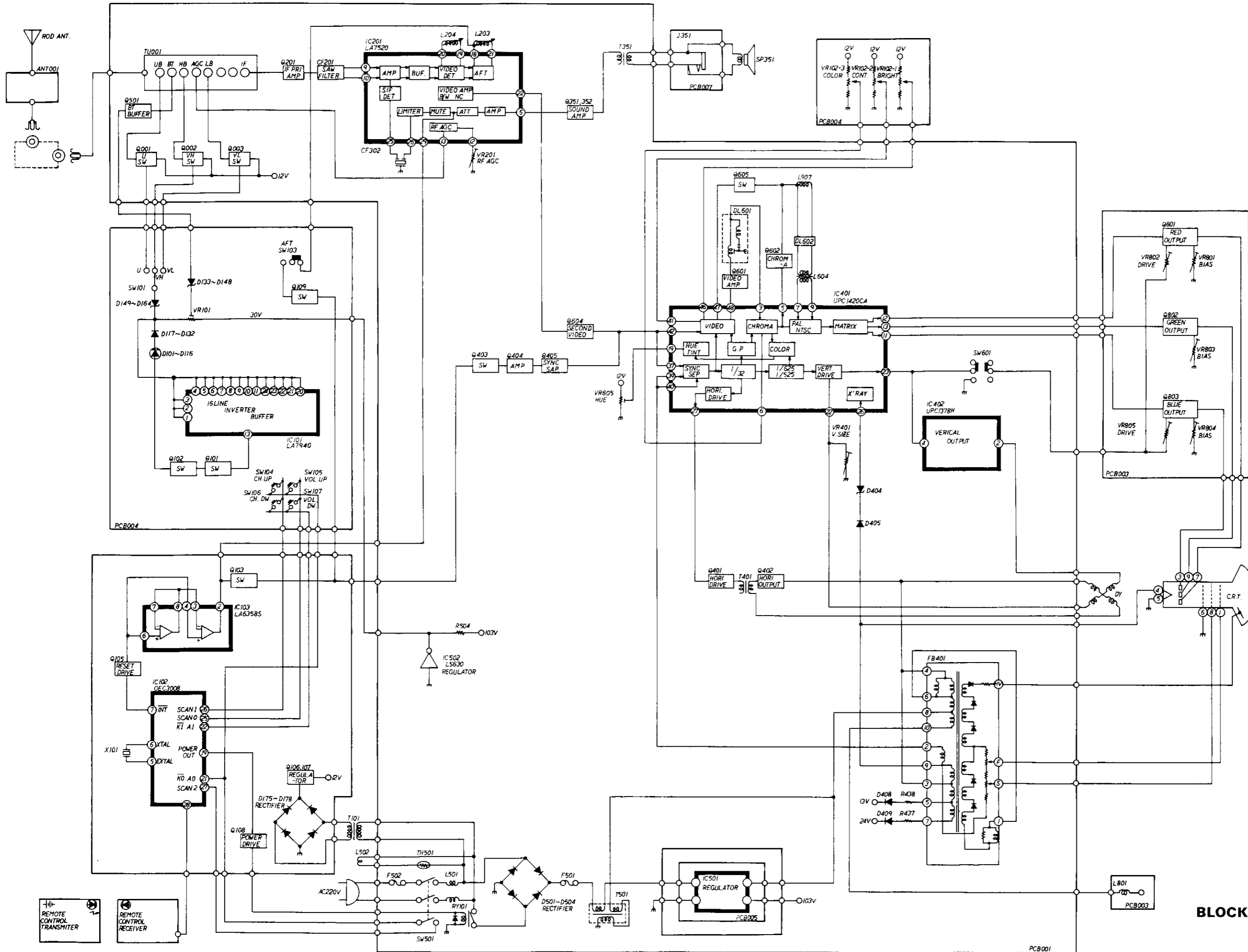

BLOCK DIAGRAM

MAIN P. C. BOARD

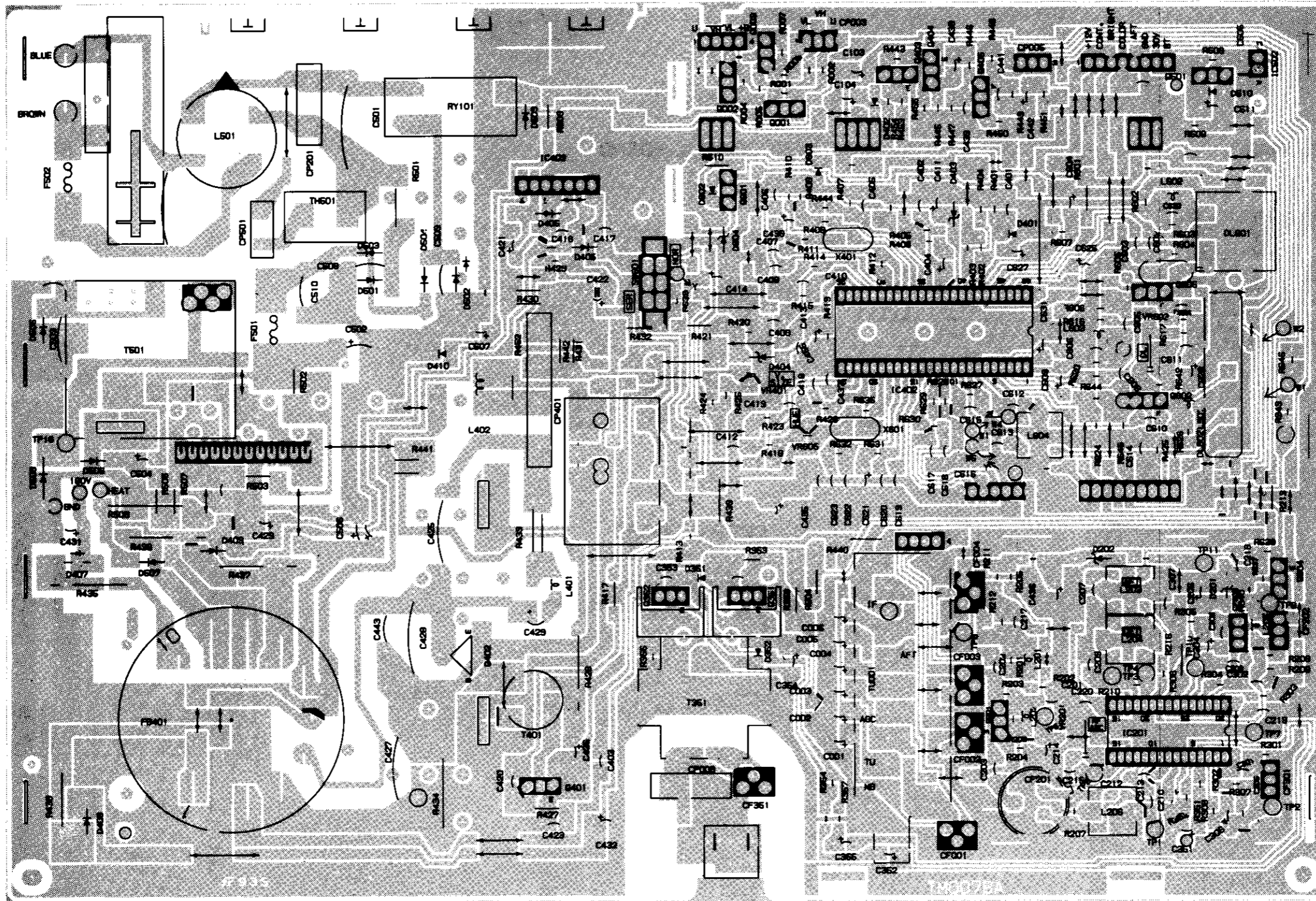

SYMBOL LIST

RESISTOR	
SEMI-FIXED RESISTOR	
CAPACITOR	
JUMPER	

MAIN P. C. BOARD

POTEME P. C. BOARD

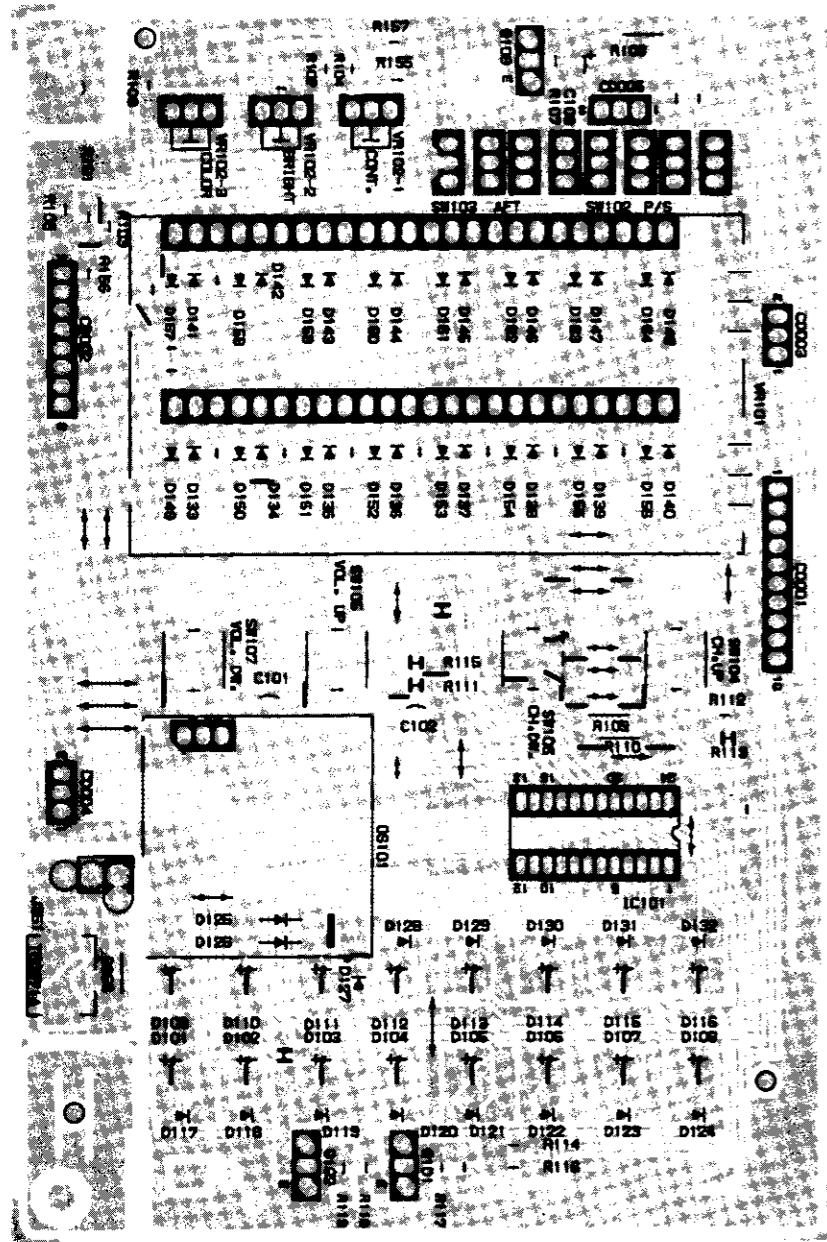

REMOCON P. C. BOARD

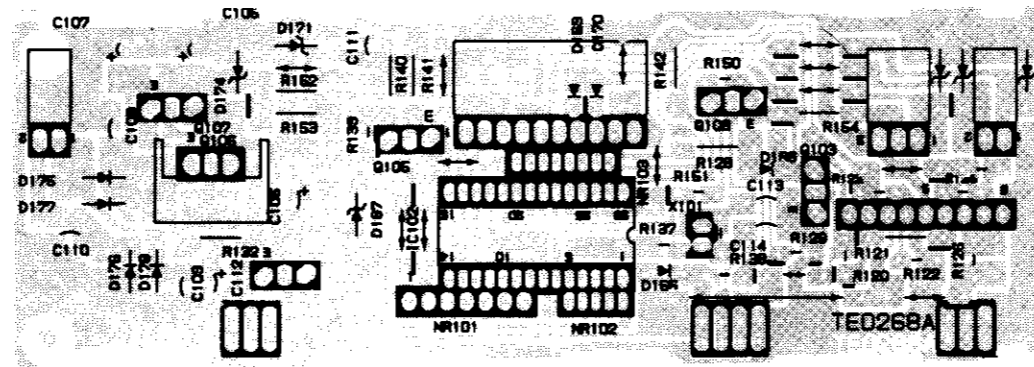

POWER P. C. BOARD

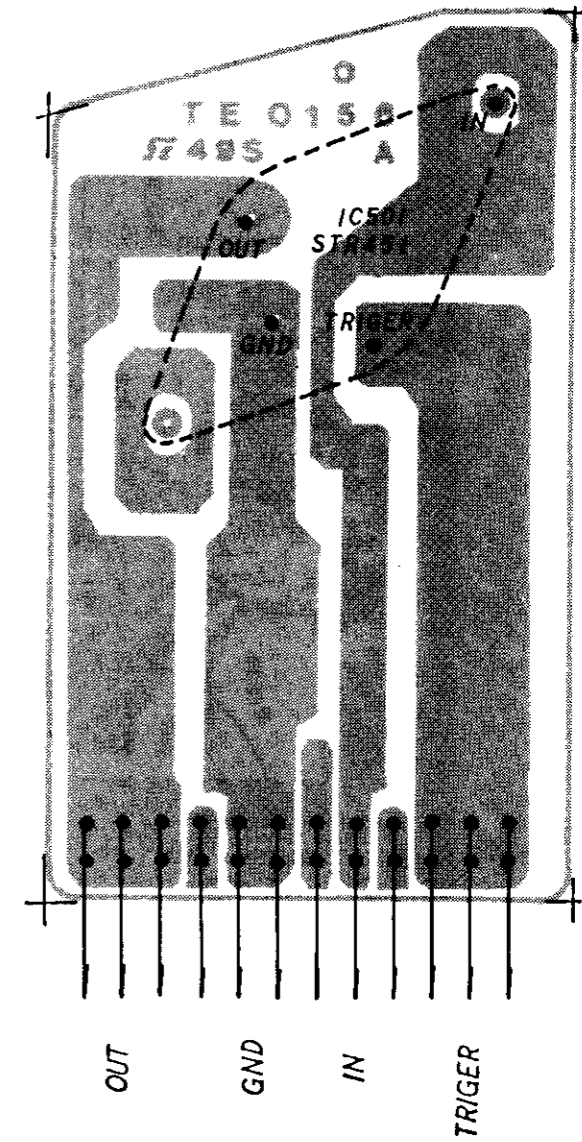

CRT P. C. BOARD

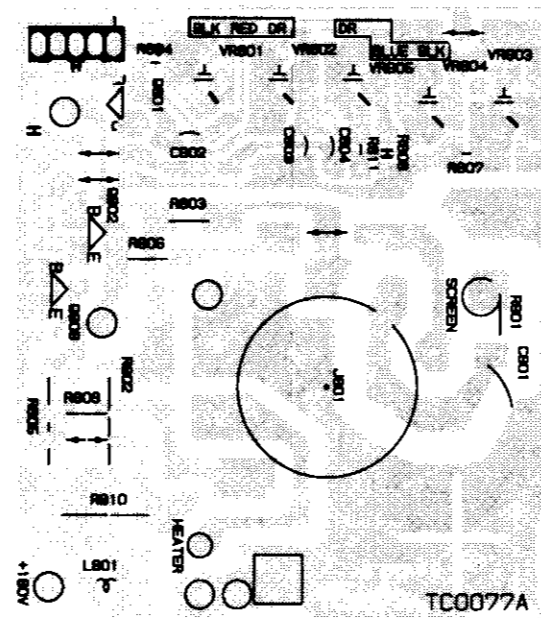

CHASSIS SCHEMATIC DIAGRAM

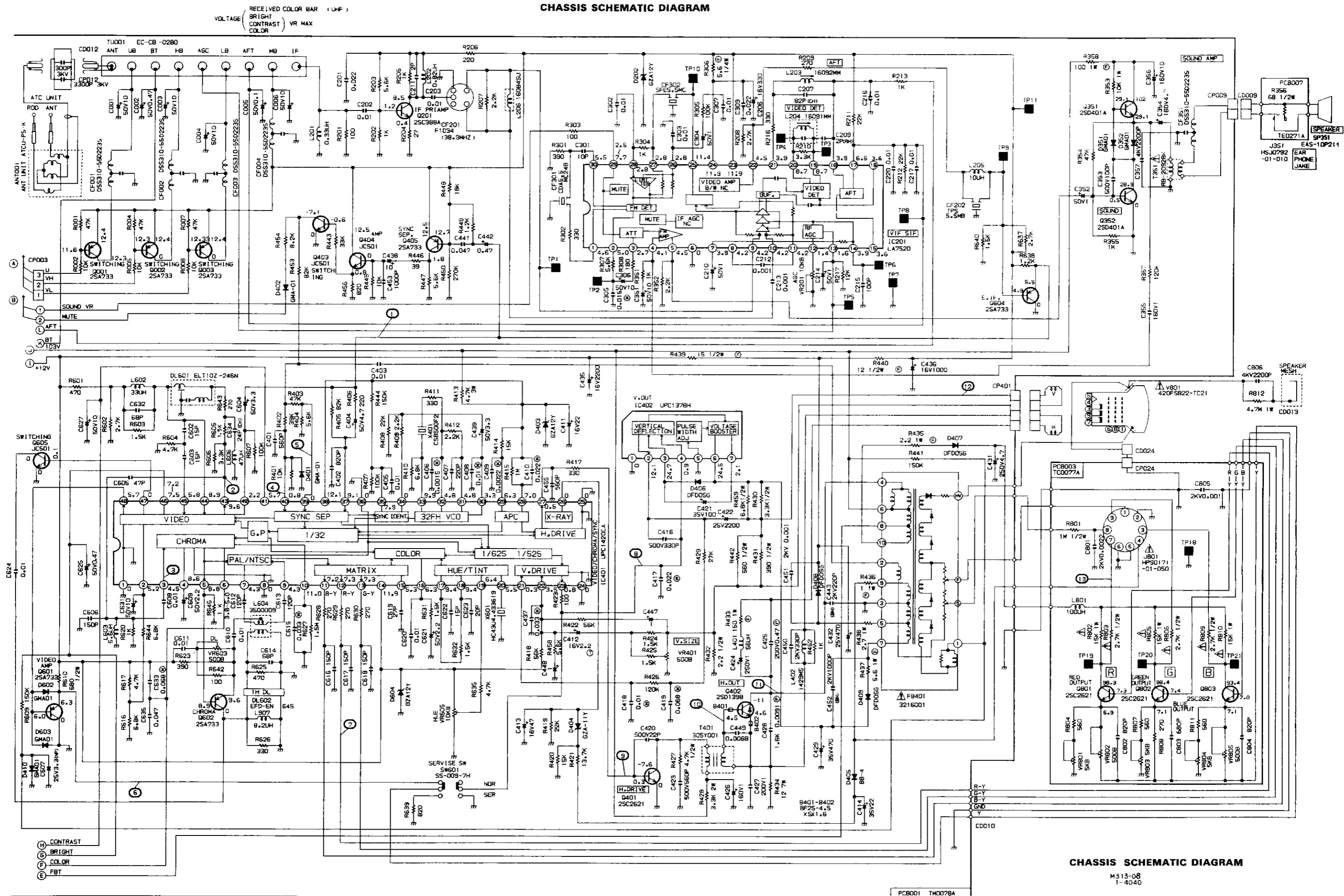

CHASSIS SCHEMATIC DIAGRAM

M313-08
1-4040

ATTENTION : LES PIÈCES RÉPARÉES PAR UN Δ ÉTANT DANGEREUSES AN POINT DE VUE SÉCURITÉ N'UTILISER QUE CELLES DÉCRITES DANS LA NOMENCLATURE DES PIÈCES.

CAUTION: SINCE THESE PARTS MARKED BY Δ ARE CRITICAL FOR SAFETY, USE ONES DESCRIBED ON PARTS LIST ONLY.

NOTE: THIS SCHEMATIC DIAGRAM IS THE LATEST AT THE TIME OF PRINTING AND SUBJECT TO CHANGE WITHOUT NOTICE.

CHASSIS SCHEMATIC DIAGRAM

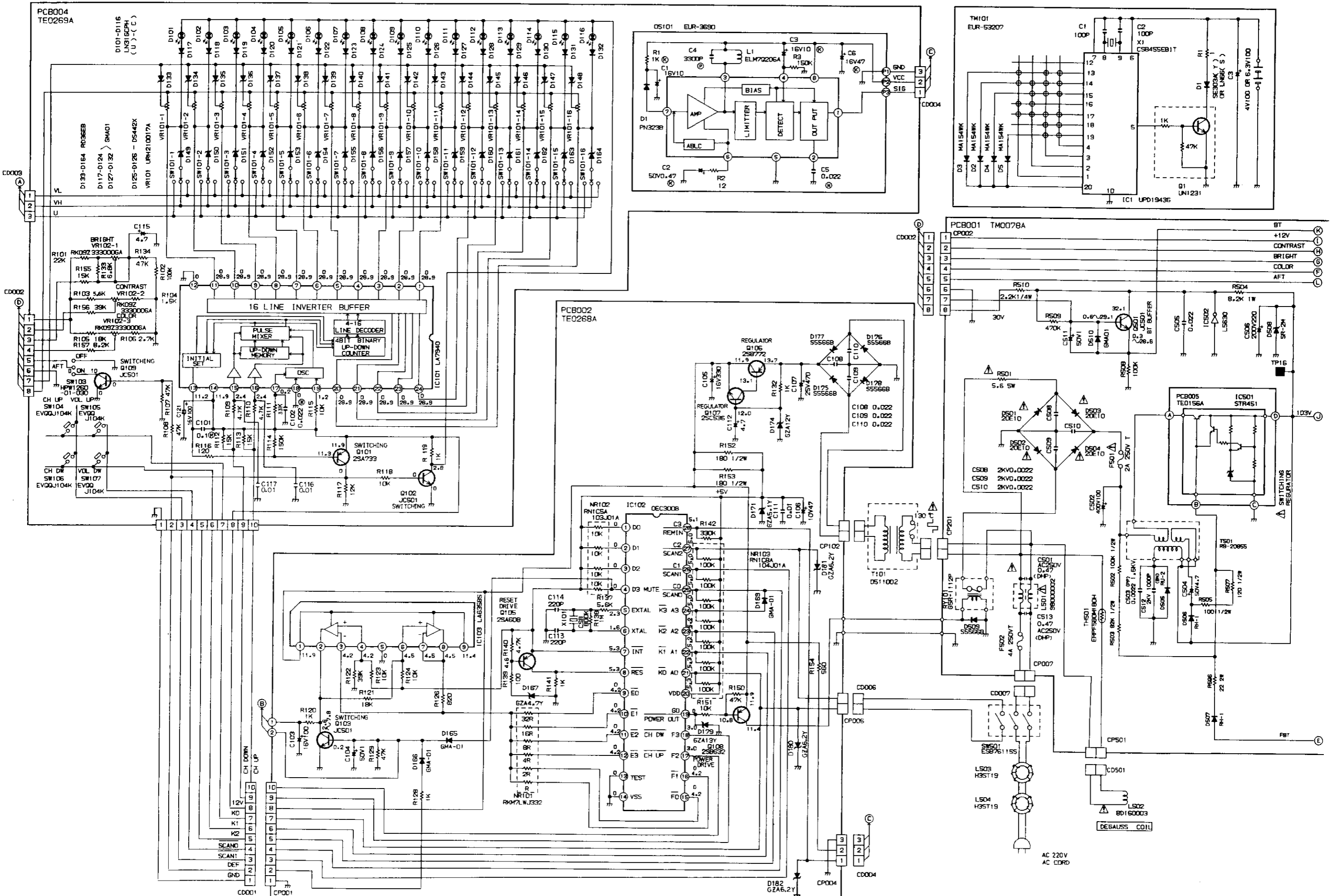

ATTENTION LES PIÈCES RÉPARÉES PAR UN ÉTANT DANGEREUSES AU POINT DE VUE SÉCURITÉ N'UTILISER QUE CELLES DÉCRITES DANS LA NOMÉNCLATURE DES PIÈCES.

CAUTION: SINCE THESE PARTS MARKED BY ARE CRITICAL FOR SAFETY USE ONES DESCRIBED ON PARTS LIST ONLY.

NOTE THIS SCHEMATIC DIAGRAM IS THE LATEST AT THE TIME OF PRINTING AND SUBJECT TO CHANGE WITHOUT NOTICE.

CHASSIS SCHEMATIC DIAGRAM

CHASSIS WAVEFORMS

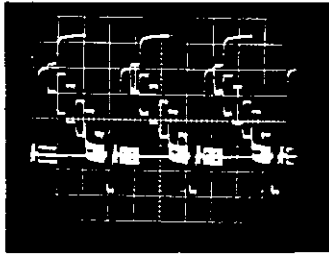

1. 1.2 Vp-p (H)

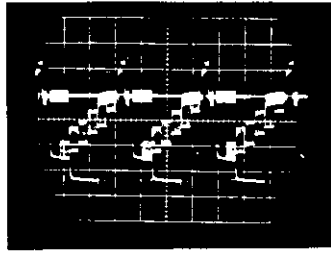

2. 2.4 Vp-p (H)

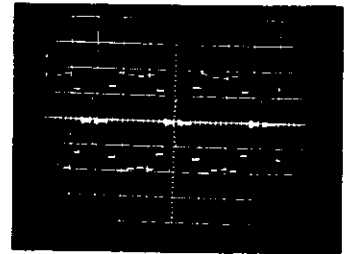

3. 0.4 Vp-p (H)

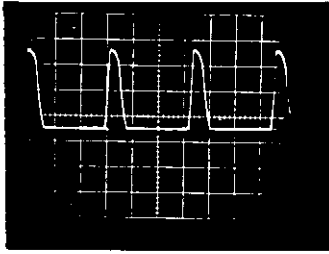

4. 6 Vp-p (H)

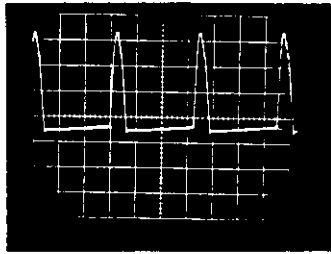

5. 8 Vp-p (H)

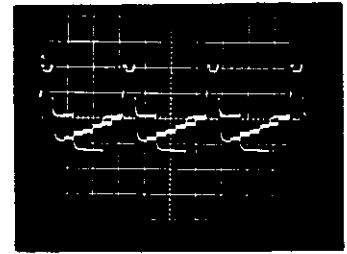

6. 3.4 Vp-p (H)

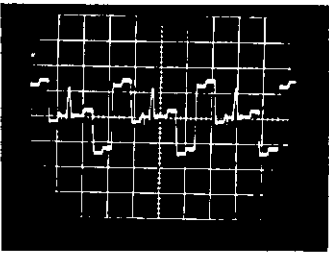

7. 1.5 Vp-p (H)

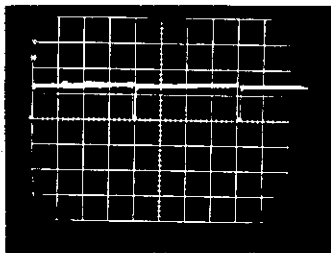

8. 0.7 Vp-p (V)

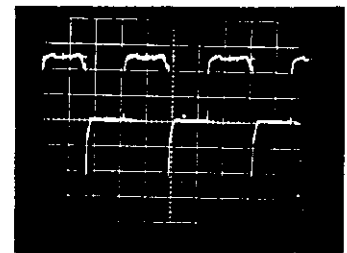

9. 1 Vp-p (H)

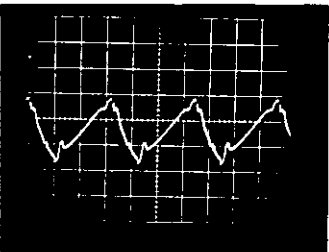

10. 13 Vp-p (H)

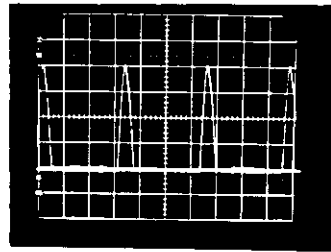

11. 800 Vp-p (H)

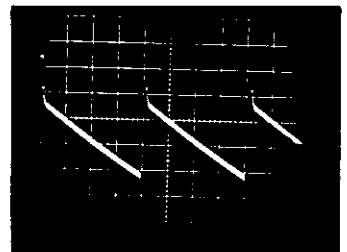

12. 17 Vp-p (H)

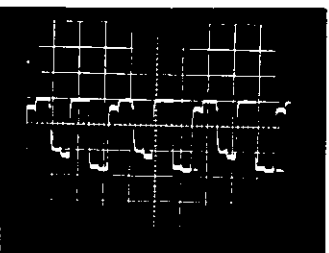

13. 140 Vp-p (H)

14" PORTABLE COLOUR TELEVISION

MECHANICAL EXPLODED VIEW

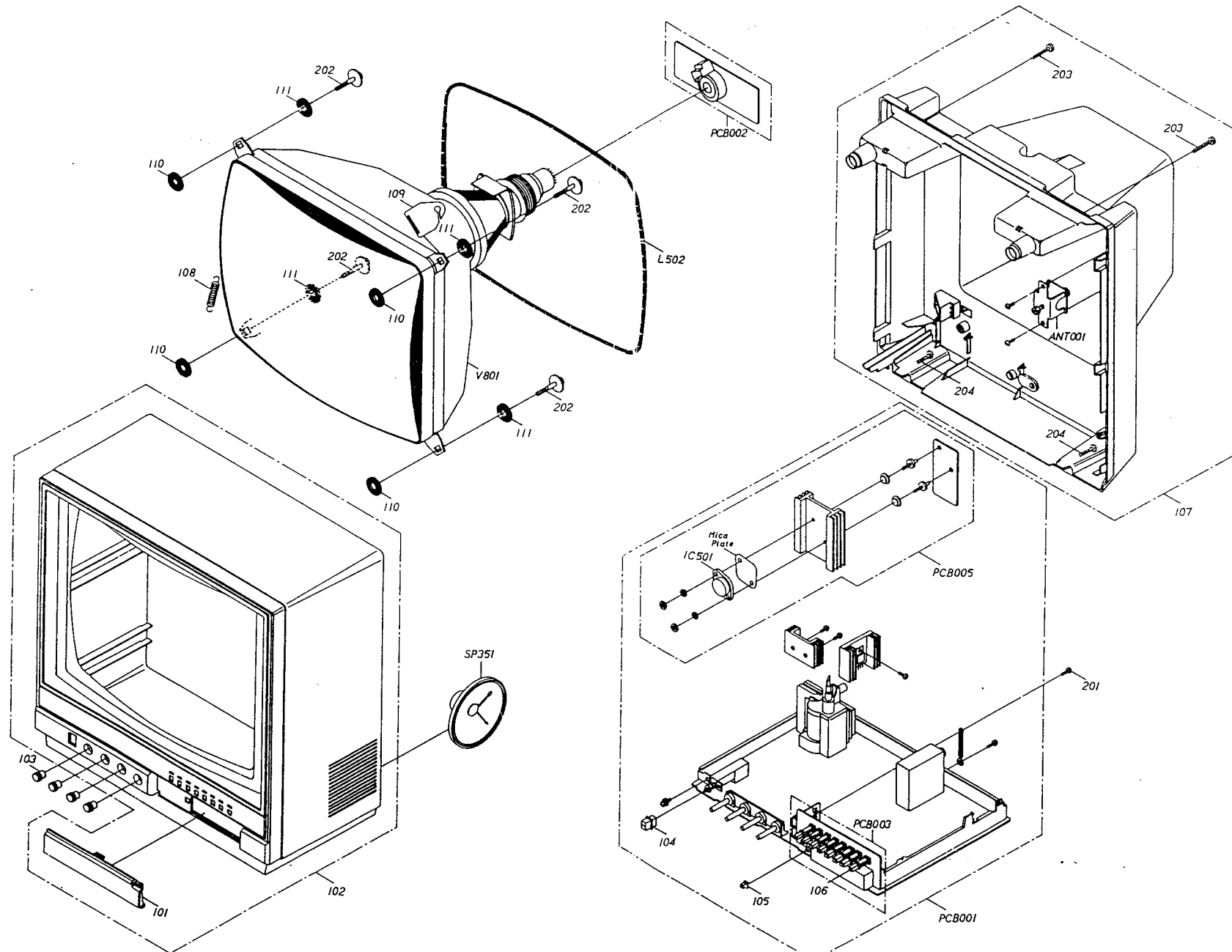

DIFFERENCES

For Interchangeability (TUNER)

REF.No	Part No.	Description	Part No.	Description
TU001	0144I07003	TUNER UE5-B51F	0144I07007	TUNER UE33-B02
R201		OPEN	RC	100 OHM 1/6W
R205		RC 470 OHM 1/6W	RC	2.2K OHM 1/6W
L201		COIL 0.22 UH	COIL	0.33 UH
L202		COIL 1.5 UH	COIL	1.2 UH

For Interchangeability (FBI)

REF.No	Part No.	Description	Part No.	Description
FB401	043714002J	FBI 3714002	043214009Q	FBI 3214009
R436		R,FUSE 3.9 OHM 1W		R,FUSE 1.0 OHM 1W
R473		RC 820K OHM 1/4W	RC	1.5M OHM 1/4W
C428		CMPP 0.01 UF 2KV	CMPP	0.0068UF 2KV
C431		CE 4.7 UF 250V	CE	22 UF 200V
C449		CC 470 PF 2KV		OPEN
PCB001	A34613010	PCB TM0107C	A34613010	PCB TM0130A
PCB002	A34613110	PCB TC0098C	A34613110	PCB TC0113A
PCB003	A34613120	PCB TE0330C	A34613120	PCB TE0391A

SCHEMATIC DIAGRAM

FBI 3214009

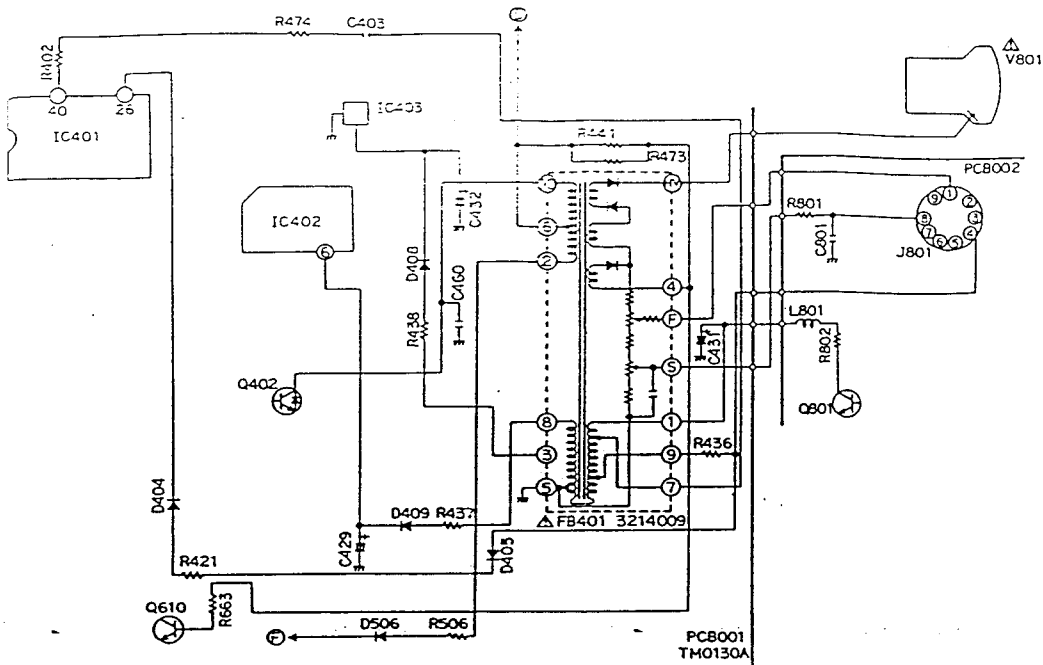

P.C.BOARD

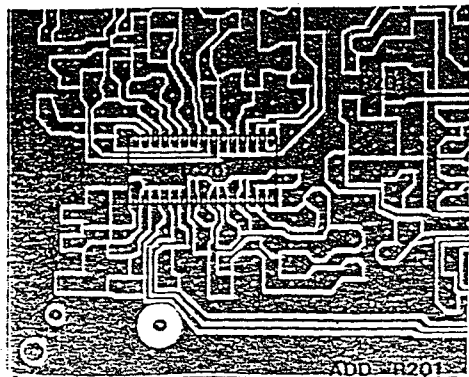

SCHEMATIC DIAGRAM

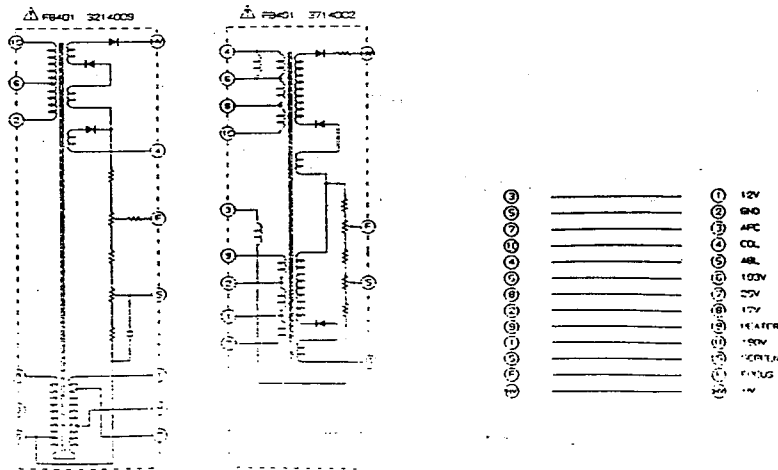
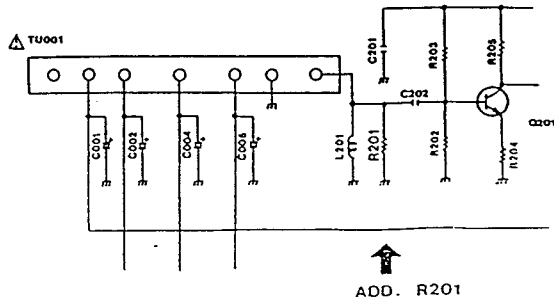

SAISHO CT 141X AND MATSUI 1420A

14" PORTABLE COLOUR TELEVISION

CHASSIS SCHEMATIC DIAGRAM

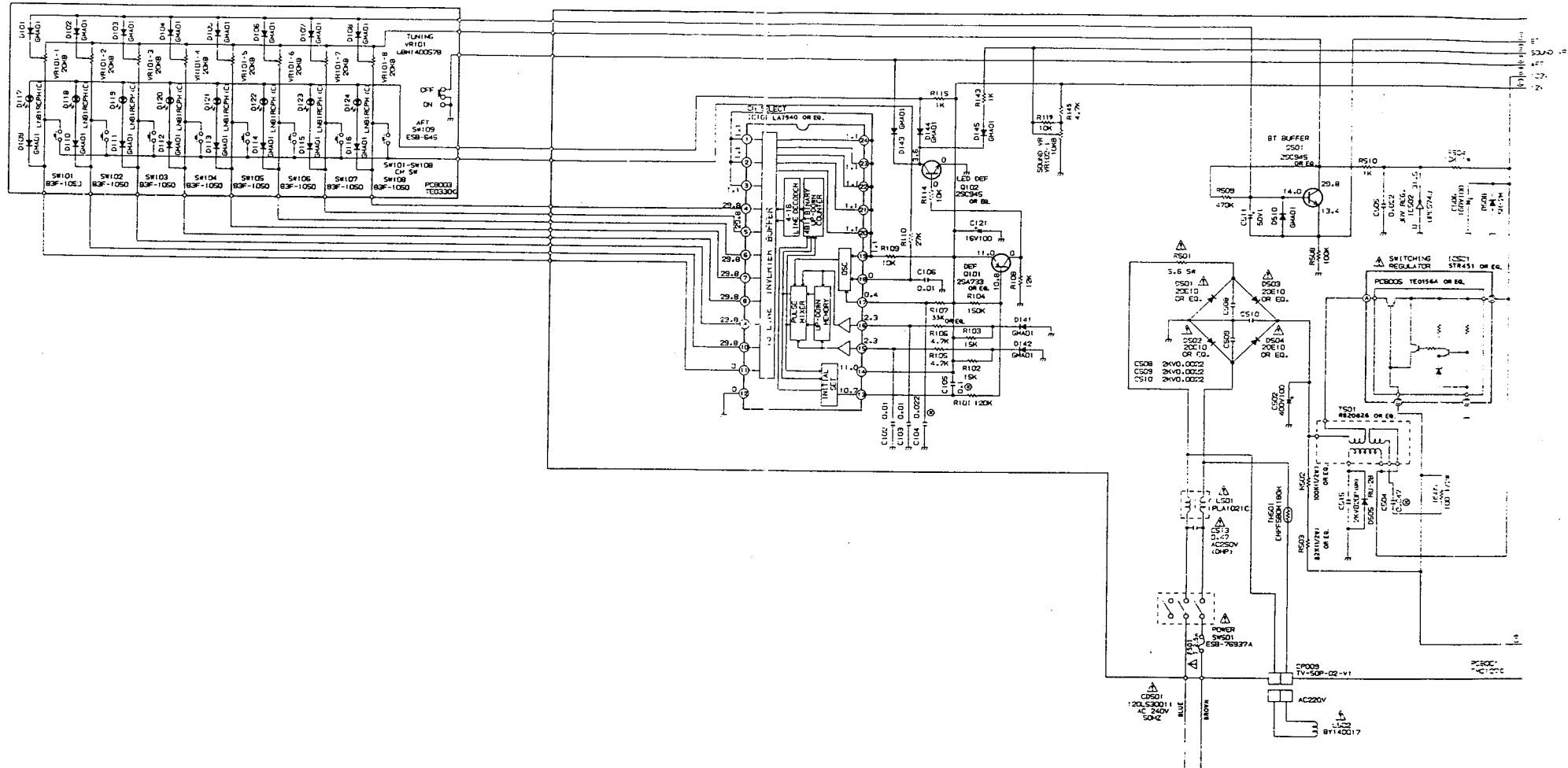

CAUTION: SINCE THESE PARTS MARKED BY Δ ARE CRITICAL FOR SAFETY, USE ONES DESCRIBED ON PARTS LIST ONLY.

ATTENTION: LES PIÈCES REPAREES PAR UN Δ ETANT DANGEREUSES AN POINT DE VUE SECURITE, UTILISER QUE CELLES DECRIITES DANS LA NOMENCLATURE DES PIÈCES.

NOTE: THIS SCHEMATIC DIAGRAM IS THE LATEST AT THE TIME OF PRINTING AND SUBJECT TO CHANGE WITHOUT NOTICE.

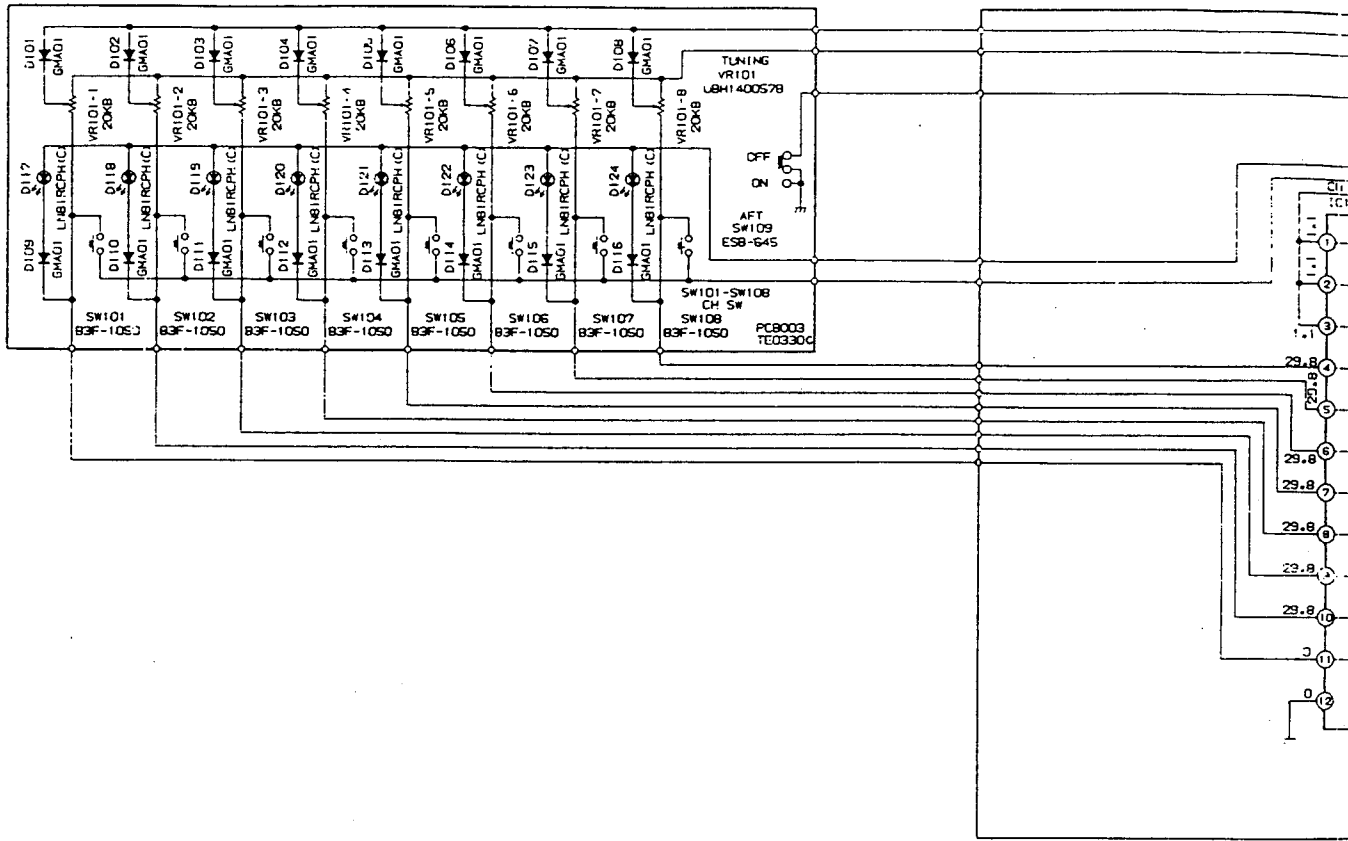

CAUTION: SINCE THESE PARTS MARKED BY Δ ARE CRITICAL FOR SAFETY, USE ONES DESCRIBED ON PARTS LIST ONLY.

ATTENTION: LES PIÈCES REPARÉES PAR UN Δ ÉTANT DANGEREUSES AN POINT DE VUE SECURITE, UTILISER QUE CELLES DECRITES DANS LA NOMENCLATURE DES PIÈCES.

14" PORTABLE COLOUR TELEVISION

CHASSIS SCHEMATIC DIAGRAM

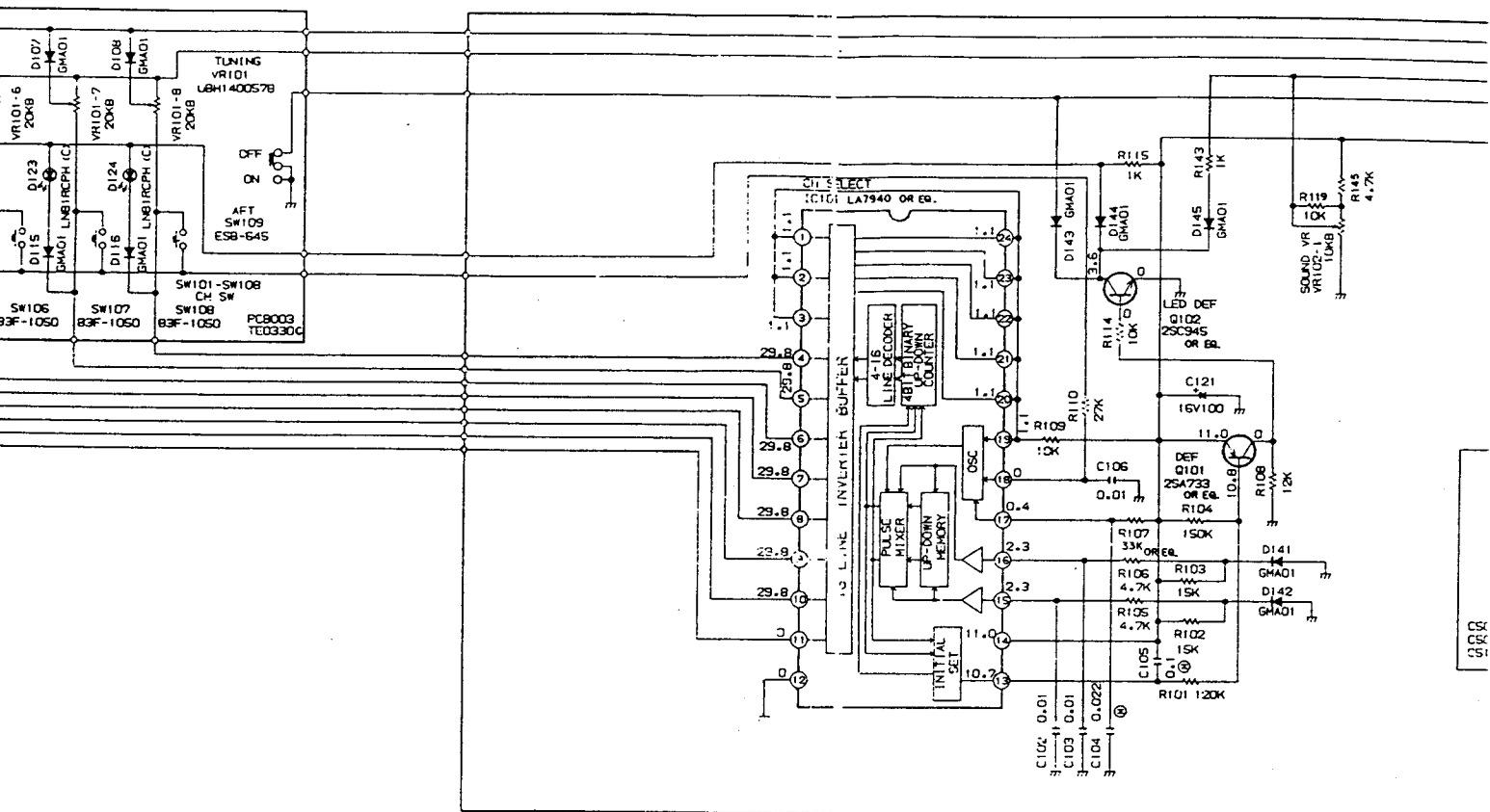

ATTENTION : LES PIECES REPARÉES PAR UN Δ ÉTANT DANGEREUSES AN POINT DE VUE SECURITE UTILISER QUE CELLES DECRIRES DANS LA NOMENCLATURE DES PIÉCES.

NOTE: THIS SCHEMATIC DIAGRAM IS THE LATEST AT THE TIME OF PRINTING AND SUBJECT TO CHANGE WITHOUT NOTICE.

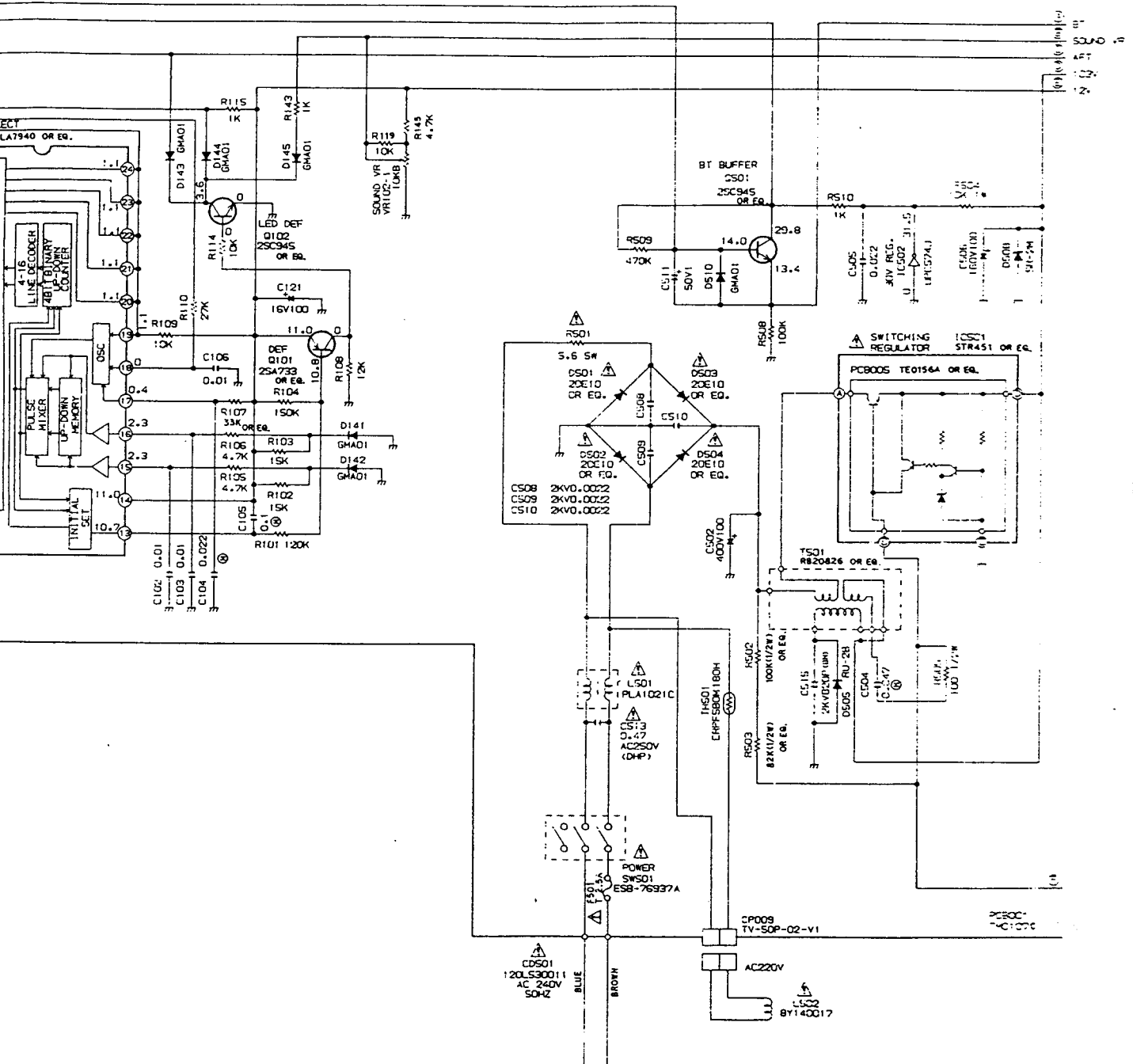

NOTE: THIS SCHEMATIC DIAGRAM IS THE LATEST AT THE TIME OF PRINTING AND SUBJECT TO CHANGE WITHOUT NOTICE.

REPLACEMENT PARTS LIST

NO.	DESCRIPTION	PART NO.
"	CABINET, FRONT	701KPB0021
"	CABINET, BACK	702KPA0157
"	GLASS, LED	713JPA0045
"	DOOR	713KPB0013
"	SHEET RATING	7222380061
"	PLATE, FRONT	7232380035
"	KNOB, VOLUME	731KPA0013
"	BUTTON, POWER	735KPA0040
"	BUTTON, AFT	735KPA0020
"	BUTTON, CHANNEL	735KPA0025
"	SHEET 255 x 8 x 0.5T	800KQ00065
"	SHEET 182 x 8 x 0.5T	800KQ00066
"	SHEET, WARINING	7260000027
"	SHEET, CAUTION	7260000026
ANT002	ANTENNA LOOP 5F500010	125F500010
ANT001	ANT UNIT HXC0808-01-010	0632000004
SP351	SPEAKER CS8T3265	070A032004
"	HOLDER, LED	779KPA0003
RESISTORS - FUSIBLE		
R358	RES FUSE 100R W50	R61582101J
R433	RES FUSE 68R W50	R61582680J
R436	RES FUSE 3R9 1W	R615813R9J
R437	RES FUSE 1R8 W50	R635821R8J
R438	RES FUSE 2R2 1W	R615812R2J

REPLACEMENT PARTS LIST

=====

NO.	DESCRIPTION	PART NO.
-----	-------------	----------

=====

RESISTORS (SEMI-FIXED)

VR201	VOL SEMI FIXED EVN-52JA00B53	V115353B02
VR603	VOL SEMI-FIXED RHE0AS20FB	V1263Q2B01
VR604	VOL SEMI-FIXED RHE0A140FB	V126314B01
VR801	VOL SEMI-FIXED RVA0911H304-1-502M	V175C53B01
VR802	RES SEMI FIXED RVA0911H304-1-501M	V175C52B01
VR401	RES SEMI FIXED EVN-KOAA00B52	V115252B03
VR605	RES SEMI FIXED EVN-KOAA00B54	V115254B03
VR805	RES SEMI FIXED RVA0911H304-3-501M	V175C52B03
VR102	VOL ROTARY EVJ4XAF35780	V019400012
	VOL POTENTION UBH140057B	V420124B06

INTEGRATED CIRCUITS

IC201	LA 7520	103DE75200
IC101	LA 7940	103D079400
IC402	UPC 1378H	102SD13780
IC401	UPC 1420CA	102DE14200
IC403	AN78M12	101A98M120
IC501	STR-451	12B3904510
IC502	UPC 574J	102990574J

REPLACEMENT PARTS LIST

=====

NO.	DESCRIPTION	PART NO.
-----	-------------	----------

=====

TRANSISTORS

Q101	SILICON 2SA733-T	TA2T007330
Q102	SILICON 2SC945-T	TC2T009450
Q201	SILICON 2SC3000-AA	TC3T030000
Q601	SILICON 2SA733QT	TA2T00733Q
Q401	SILICON 2SC2271	TC30022710
Q402	SILICON 2SD1397-ORI-YB	

DIODES

D501, D502, D503,504	SILICON 20E10	D28Q20E100
D101, D102,103 D104,105,106,107,108,109, D110,111,112,113,114,115, D116,141,142,143,144,145, D351,352	SILICON GMA-01-BT	D13TGMA010
D404	ZENER GZA11-Y-BT	D93T01100Y
D408, D409	RECTIFIER DFH10G-KB4	D23FDFH10G
D405, D406,407	RECTIFIER DFD05G	D23TDFD05G
D505	SILICON RU-2B	D2B00RU2B0
D506	RECTIFIER RH-1	D2B000RH10
D508	AVARANSHU SR-2M	S2B000SR2M
D117, D118,119 D120,121,122,123,124	LED LN81RCPH-(C)	0021121050

REPLACEMENT PARTS LIST

=====

NO.	DESCRIPTION	PART NO.
-----	-------------	----------

=====

TRANSFORMERS

T351	SOUND OUTPUT RB-20883K	045128004E
T401	HORIZONTAL DRIVE 305Y001	03305Y001G
T501	SWITCHING RB-20826	0481280015
FB401	LOP TRANS 3714002	0437140021

COILS/FILTERS

L604	COIL, MATCHING 3500009	0335000094
L204	COIL, VIDEO IFT 16091MM	033500005M
L203	COIL, VIDEO IFT 16092MM	033602002M
L201	COIL, EL0606RA-R22M 0.22UH	021673R22M
L202	COIL, EL0606RA-1R5K 1.5UH	0216731R5K
L205	COIL, EL0606RA-150K 15UH	021673150K
L206	COIL, C8-AZ-R91K 0.91UH	021705R91K
L602	COIL, EL0606RA-560K 56UH	021673560K
L606	COIL, EL0606RA-470K 47UH	021673470K
L401	COIL, EL0909RA-472K 4.7MH	021679472K
L605	COIL, EL0606RA-8R2K 8.2UH	02167382RK
L801	COIL, EL0606RA-101K 100UH	021673101K
L603	COIL, EL0606RA-5R6K 5.6UH	0216735R6K
L402	COIL, LINEARITY 21000008	0221000008
L502	COIL, DEGAUS 028Y140017	028Y140017
L501	FILTER, LINE AC	029A000004
CF201	FILTER, SAW TSF1306C	1028039R52
CF202	FILTER, CER TRAP TPS6.0MB	1012106R01
CF302	FILTER, CERAMIC SFE6.0MB	1012006R01

REPLACEMENT PARTS LIST

NO.	DESCRIPTION	PART NO.
COILS/FILTERS		
CF301	FILTER, CER DISCRIMINATOR	1012206R04
SWITCHES		
SW109	SWITCH, PUSH ESB-645	0501142001
SW501	SWITCH, PUSH ESB-76937A	0530102008
SW101, SW102,103, SW104,105,106,107,108	SWITCH, TACT B3F-1050	0504701002
SW601	SWITCH, SLIDE SS121-B	0510422003
PC BOARDS		
TM0107B	PC BOARD ASS'Y (PCB001)	13TM0107BB
TC009BB	PC BOARD ASS'Y (PCB002)	13TC0098BB
TE0330B	PC BOARD ASS'Y (PCB003)	13TE0330BB
TE0156A	PC BOARD ASS'Y (PCB005)	13TE0156A3
TU001	TUNER UHF UE5-B51F	0144107003
DL601	DELAY ELT-10Z246N	1031000601
DL602	DELAY LINE GLASS EFD-EN645A31F	104114R43G
V801	CR TUBE 370KR822-TC20	092F140409
TH501	DEGAUS ELEMENT ERP-F5BOM180H	D810M180H0
J301	JACK, RCA 3.5	0602101007
J801	CRT SOCKET	0662120007
CD501	CORD AC	120L530011
EAR351	EARPHONE 3.5 FA1, 3M 16R	074J130001
X601	CRYSTAL HC49V4433.619	100H4R4306
	INSTRUCTION BOOK	INSBKCT141X

SAISHO CT 141X AND MATSUI 1420A

14" PORTABLE COLOUR TELEVISION

N O T E S

REPLACEMENT PARTS LIST

NO.	DESCRIPTION	PART NO.
"	CABINET, FRONT	701KPJ0053
"	CABINET, BACK	702KPA0157
"	GLASS, LED	713JPA0045
"	DOOR	713KPB0014
"	SHEET RATING	7222890029
"	PLATE FRONT	7232890012
"	KNOB, VOLUME	731KPA0013
"	BUTTON, POWER	735KPA0040
"	BUTTON, AFT	735KPA0020
"	BUTTON, CHANNEL	735KPA0026
"	SHEET, LIGHTRON	791KHA0052
"	SHEET 255 x 8 x 0.5T	800KQ00065
"	SHEET 182 x 8 x 0.5T	800KQ00066
"	SHEET, WARNING	7260000027
"	SHEET, CAUTION	7260000026
ANT002	ANTENNA LOOP 5F500010	125F500010
ANT001	ANTENNA UNIT HXC0808-01-010	0632000004
SP351	SPEAKER CS8T3265	070A032002
"	HOLDER LED	779KPA0003
RESISTORS		
R358	RES FUSE 100R W50	R61582101J
R433	RES FUSE 68R W50	R61582680J
R436	RES FUSE 3R9 1W	R615813R9J
R437	RES FUSE 1R8 W50	R635821R8J
R438	RES FUSE 2R2 1W	R615812R2J

REPLACEMENT PARTS LIST

=====
NO. DESCRIPTION PART NO.
=====

RESISTORS (SEMI FIXED)

VR201	VOL SEMI FIXED EVN-52JA00B53	V115353B02
VR401	VOL SEMI FIXED EVN-KOAA00B52	V115252B03
VR603	VOL SEMI FIXED RHEOAS20FB	C1263Q2B01
VR604	VOL SEMI FIXED RHEOA140FB	V126314B01
VR801	VOL SEMI FIXED RVA0911H304-1-502M	V175C53B01
VR605	VOL SEMI FIXED EVN-KOAA00B54	V115254B03
VR802	VOL SEMI FIXED RVA0911H304-1-501M	V175C52B01
VR102	VOL ROTARY EVJ4XAF35780	V019400Q12
VR101	VOL POTENTION UBH140057B	V420124B06
VR804	VOL SEMI FIXED RVA0911H304-3-502M	V175C53B03
VR805	VOL SEMI FIXED RVA0911H304-1-501M	V175C52B03

INTEGRATED CIRCUITS

IC201	LA7520	103DE75200
IC101	LA7940	103D079400
IC402	UPC1378H	102S013780
IC401	UPC1420CA	102DE14200
IC403	AN78M12	101A98M120
IC501	STR-451	12B3904510
IC502	UPC574J	102990574J

REPLACEMENT PARTS LIST

```

=====
NO.      DESCRIPTION                                PART NO.
=====

```

TRANSISTORS

Q101	2SA733-T	SILICON	TA2T007330
Q102	2SC945-T	SILICON	TC2T009450
Q201	2SC3000-AA	SILICON	TC3T030000
Q601, Q602,604	2SA733QT	SILICON	TA2T00733Q
Q351, Q352,401	2SC2271	SILICON	TC30022710
Q402	2SD1397-ORI-YB	SILICON	TD3F013970

DIODES

D501, D502,503 D504	20E10		D28020E100
D101, D102,103 D104,105,106,107, D108,109,110,111,112,113,114 D115,116,141,142,143,144,145 D351,352	GMA-01-BT		D13TGMA010
D404	GZA11-Y-BT		D93T01100Y
D408, D409,410	DFH10G-KB4		D23FDH10G
D405, D406,407	DFD05G		D23TDFD05G
D505	RU-2B		D2B00RU2B0
D506	RH-1		D2B000RH10
D508	SR-2M		D2B000SR2M
D117, D118,119, D120,121,122,123,124	LED LN81RCPH-(C)		0021121050

MATSUI 1420A 14" PORTABLE COLOUR TELEVISION

REPLACEMENT PARTS LIST

=====
NO. DESCRIPTION PART NO.
=====

TRANSFORMERS

T351	SOUND OUTPUT RB-20883K	045128004E
T401	HORIZONTAL DRIVE 305Y001	03305Y001G
T501	SWITCHING RB-20826	0481280015
	L.O.P. TRANS 3714002	0437140021

COILS/FILTERS

L604	COIL, MATCHING 3500009	0335000094
L204	COIL, VIDEO IFT 16091MM	033500005M
L203	COIL, VIDEO IFT 16092MM	033602002M
L201	COIL, EL0606RA-R22M 0.22UH	21673R22M
L202	COIL, EL0606RA-1R5K 1.5UH	0216731R5K
L205	COIL, EL0606RA-150K 15UH	021673150K
L206	COIL, C8-AZ-R91K 0.91UH	021705R91K
L602	COIL, EL0606RA-560K 56UH	021673560K
L603	COIL, EL0606RA-5R6K 5.6UH	0216735R6K
L401	COIL, EL0909RA-472K 4.7MH	021679472K
L605	COIL, EL0606RA-8R2K 8.2UH	0216738R2K
L606	COIL, EL0606RA-470K 47UH	021673470K
L502	COIL, DEGAUS 028Y140017	028Y140017
L801	COIL, EL0606RA-101K 100UH	021673101K
L501	FILTER, LINE AC	029A000004
ANT003	COIL, BALUM SU5011	023V000003
L402	COIL, LINEARITY	0221000008
CF201	FILTER, SAW TSF1306C	1028039R52

REPLACEMENT PARTS LIST

NO.	DESCRIPTION	PART NO.
COILS/FILTERS		
CF202	FILTER, CER TRAP TPS6.0MB	1012106R01
CF302	FILTER, CERAMIC SFE6.0MB	1012006R01
CF301	FILTER, CER DISCRIMINATOR	1012206R04
SW109	SWITCH, PUSH ESB-645	0501142001
SW101,	SWITCH, TACT B3F-1050	0504701002
SW102,103		
SW104,105,106,107,108		
SW501	SWITCH, PUSH ESB-76937A	0530102008
SW601	SWITCH, SLIDE SS121-B	0510422003
PC BOARDS		
TM0107B	PC BOARD ASS'Y (PCB001)	13TM0107BB
TC0098B	PC BOARD ASS'Y (PCB002) (CTV)	13TC0098BB
TE0330B	PC BOARD ASS'Y (PCB003)	13TE0330BB
TE0156A	PC BOARD ASS'Y (PCB005)	13TE0156A3
TU001	TUNER, UHF UE5-B51F	0144707003
DL601	DELAY ELT-10Z246N	1031000601
DL602	DELAY LINE GLASS EFD-EN64531F	104114R43G
	HOLDER, FUSE 7800-6268	067H000001
V801	CR TUBE 3702B22-TC20	092F140409
TH501	DEGAUS ELEMENT ERP-F5B0M180H	D810M180H0
X601	CRYSTAL HC49U4433.619	100H4R4306
J301	JACK, RCA 3.5	0602101007
J801	CRT SOCKET HPS1171-01-050	0662120007
CD501	CORD AC	120L530011

MATSUI 1420A 14" PORTABLE COLOUR TELEVISION

REPLACEMENT PARTS LIST

=====

NO.	DESCRIPTION	PART NO.
-----	-------------	----------

=====

PC BOARDS

EAR351	EARPHONE 3.5FA1,3M,16R	074J130001
	INSTRUCTION BOOK	INSBK1420A