

# JVC

## SERVICE MANUAL

MODEL

**RC-M90JW/W**

FM-AM-SW1-SW2-SW3-SW4-SW5-SW6

8-BAND STEREO RADIO

CASSETTE RECORDER

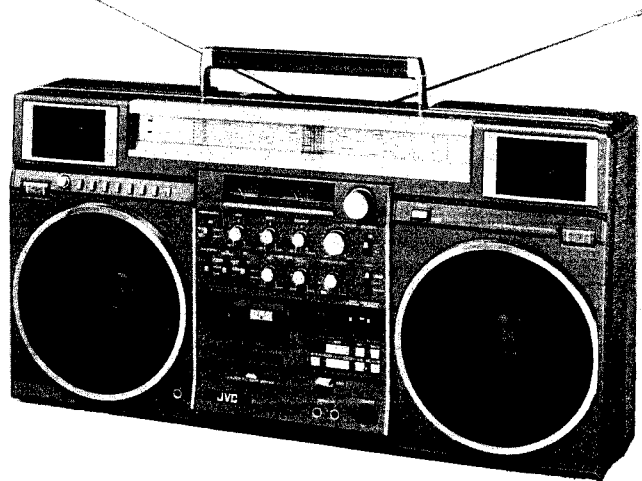

No. 1462  
November 1981

# Contents

	Page
Specifications .....	2
Features .....	2
Names of Parts .....	3
Main Parts Location .....	4
Removal of the Main Parts .....	4
Removal of the Mechanical Parts .....	6
How to Engage Dial Cord .....	7
Safety Precautions .....	7
Tuner Alignment .....	8
Adjustment of Cassette Recorder Amplifier .....	10
Adjustment of Cassette Mechanism .....	10
Block Diagrams (Tuner, Pre-amp, Main Amp and Mecha. Control Circuit) .....	11-14
Standard Schematic Diagrams (Tuner, Pre-amp, Main Amp and Mecha. Control Circuit) .....	15-18

	Page
Wiring Connection (1) .....	19
Wiring Connection (2) .....	20
Rear Cabinet Parts, Parts List .....	21
Enclosure Assembly and Electrical Parts List .....	22
Enclosure Assembly and Electrical Parts (1) .....	23
Enclosure Assembly and Electrical Parts (2) .....	24
Mechanical Component Parts .....	26
Mechanical Component Parts List .....	27
Tuner P.W.B. Parts, Parts List .....	29
Pre-amp P.W.B. Parts, Parts List .....	32
Main Amp. P.W.B. Parts, Parts List .....	36
Other P.W.B. Parts, Parts List .....	39
Packing, Packing Material Parts List .....	41
Accessories .....	Back Cover

## Specifications

Semiconductors : 21 ICs, 77 transistors & 1 FET  
 Speakers : 20 cm x 2, 6.5 cm x 2

### Tuner section

Frequency ranges : FM 88 - 108 MHz  
 AM 540 - 1600 kHz  
 SW1 1.6 - 3.5 MHz  
 SW2 3.5 - 6.0 MHz  
 SW3 5.95 - 6.2 MHz  
 SW4 6.0 - 11.0 MHz  
 SW5 11.0 - 18.5 MHz  
 SW6 18.5 - 26.0 MHz

Antennas : Telescopic antennas for FM & SW  
 Ferrite core antenna for AM & SW1  
 External antenna terminal (for FM & SW) provided

### Tape recorder section

Track system : 4-Track 2-channel stereo  
 Frequency response: 30 - 17,000 Hz (with metal tape)  
 30 - 16,000 Hz (with chrome tape)  
 30 - 15,000 Hz (with normal tape)  
 Wow & flutter : 0.05% (WRMS)  
 S/N ratio : 54 dB (Metal)  
 Rewind time : Within 95 sec. (C-60 cassette)  
 Fast forward time : Within 95 sec. (C-60 cassette)

### Amplifier section

Power output : Max. 40 W (20 W + 20 W)  
 Music power of 60 W (30 W + 30 W)  
 Input jacks : Mic x 2 (0.45 mV, 1.3 k $\Omega$ )  
 Mix. Mic x 2 (0.8 mV, 1.6 k $\Omega$ )  
 Line in x 2 (input level 120 mV min., impedance; 100 k $\Omega$ )  
 Phono in x 2 (input level 3 mV min., impedance; 47 k $\Omega$ )  
 Remote control jack x 1 (8-pin)  
 DC in x 1  
 Output jacks : Ext. speaker x 2 (load impedance 6 - 16  $\Omega$ )  
 Headphones (2 mW/8  $\Omega$ , load impedance 8 - 32  $\Omega$ )  
 Line out x 2 (0.3 V, impedance; 2.7 k $\Omega$ )  
 Power supply : DC 15 V (10 "R20" cells) Car battery through a car battery adapter  
 AC 240/220/110 V, 50/60 Hz (RC-M90W)  
 AC 240/220/120 V, 50/60 Hz (RC-M90JW)  
 AC 240 V, 50/60 Hz (RC-M90WH)  
 Power consumption: 70 W (RC-M90W), 61 W (RC-M90JW)  
 Dimensions : 668(W) x 350(H) x 177(D) mm  
 Weight : 10.0 kg (without batteries)  
 11.1 kg (with batteries)

Design and specifications subject to change without notice.

No. 1462

## Features

- Newly developed 2-way, 4-speaker system with polyurethane laminated cone woofers.
  - 2-way, 4-speaker system with two 20 cm woofers and two 6.5 cm tweeters.
  - Uses newly developed polyurethane laminated cone in the woofers to reproduce rich, realistic sound.
- High total power output of 40 W (20 W per channel). Peak music power of 60 W (30 W per channel).
- 2-motor full logic control mechanism.
  - Provided with a remote control jack.
  - Timer standby mechanism.
  - Cue and review facilities.
- Multi music scan mechanism for skipping up to 5 different program selections.
  - "Under license of Stear S.A., Brussel, Belgium"
- Built-in SUPER ANRS, ANRS/DOLBY\* B noise reduction systems to greatly reduce tape hiss and improve dynamic range.
- Metal tape compatibility.
  - METAPERM recording/playback head and 2-gap SA (Sen-Alloy) erase head.
  - 3-position tape select switch for Metal, CrO<sub>2</sub> and Normal tapes.
- Multi mixing facilities when using wired microphone.
  - Provided with mixing volume control.
  - Provided with two microphone jacks (6.3 mm dia.) for exclusively microphone mixing.
- 8-Band radio selection including FM, AM, SW1 - SW6.
- Manual/Automatic Recording Level control.
- Record muting facility for leaving non-recorded sections.
- Equipped with recording and external input (PHONO/LINE IN) jacks.
  - Built-in RIAA equalizer for direct connection of a turntable.
- External output and external speaker jacks.
- External antenna terminals for FM and SW.

\* "Dolby" and the double-D symbol are trademarks of Dolby Laboratories Licencing Corporation.

# Names of Parts

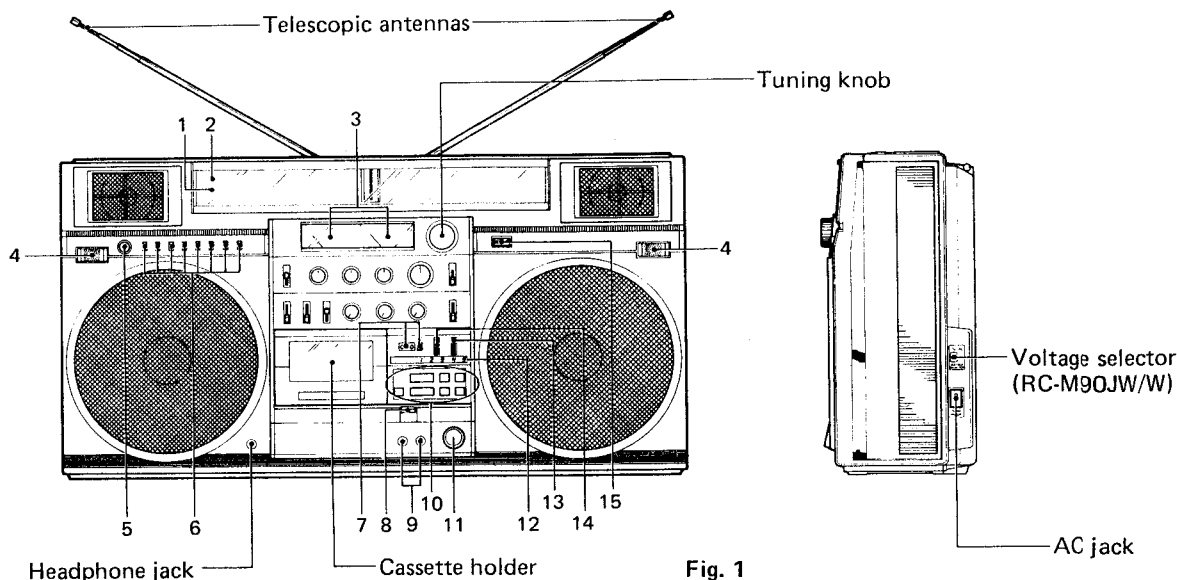

Fig. 1

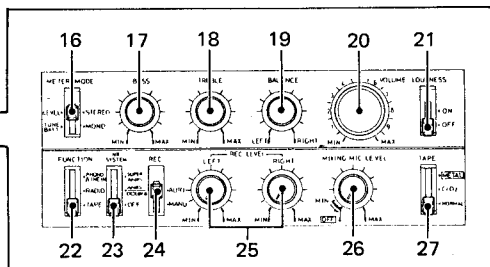
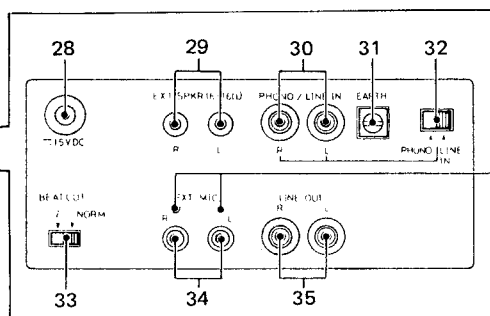
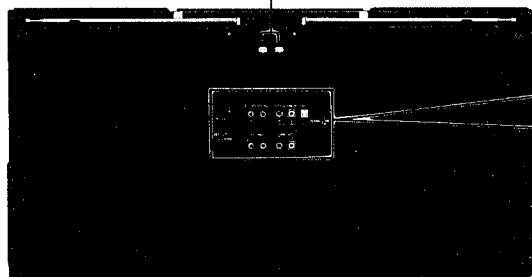

Fig. 2

Ext. antenna terminals



Dummy holes for connecting microphones with remote control plugs

Fig. 3

- |  |   |
|--|---|
| <ol style="list-style-type: none"> <li>1. POWER indicator</li> <li>2. FM STEREO indicator</li> <li>3. 3-way meter</li> <li>4. Built-in microphones (L, R)</li> <li>5. FINE TUNING knob</li> <li>6. BAND select buttons</li> <li>7. Tape counter with reset button</li> <li>8. EJECT button</li> <li>9. MIXING MIC jacks</li> <li>10. Cassette operation buttons             <ul style="list-style-type: none"> <li>■ STOP button</li> <li>○ REC button</li> <li>   PAUSE button</li> <li>◀◀ REVIEW button</li> <li>▶▶ PLAY button</li> <li>▶▶ CUE button</li> </ul> </li> <li>11. REMOTE jack</li> <li>12. MULTI MUSIC SCANNER indicators</li> <li>13. MULTI MUSIC SCANNER switch</li> <li>14. TIMER STANDBY switch</li> <li>15. POWER switch</li> </ol> | <ol style="list-style-type: none"> <li>16. METER/MODE switch</li> <li>17. BASS control</li> <li>18. TREBLE control</li> <li>19. BALANCE control</li> <li>20. VOLUME control</li> <li>21. LOUDNESS switch</li> <li>22. FUNCTION switch</li> <li>23. NR SYSTEM switch</li> <li>24. REC switch (AUTO – MANU)</li> <li>25. REC LEVEL controls</li> <li>26. MIXING MIC LEVEL control</li> <li>27. TAPE switch</li> <li>28. External DC input jack (DC 12 V = RC-M90JW<br/>DC 15 V = RC-M90WVWH)</li> <li>29. External speaker jacks (EXT SPKR – 6~16 Ω)</li> <li>30. PHONO/LINE IN jacks</li> <li>31. EARTH terminal</li> <li>32. PHONO/LINE IN selector switch</li> <li>33. BEAT CUT switch</li> <li>34. External microphone jacks (EXT MIC)</li> <li>35. Line output jacks (LINE OUT)</li> </ol> |
|--|---|

## Main Parts Location

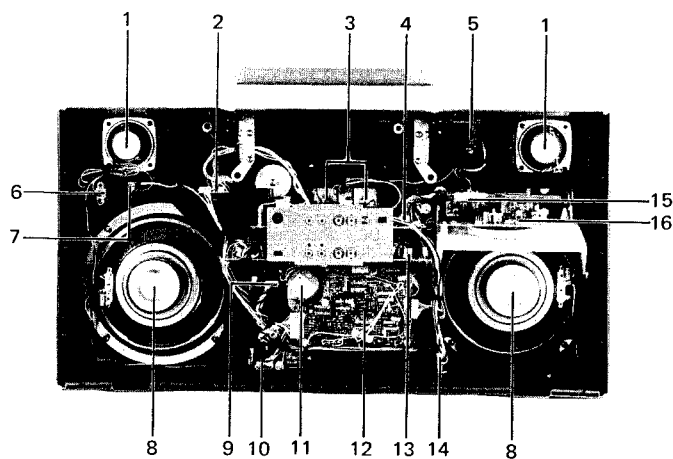

Fig. 4

1. Speakers (tweeter)
2. Power switch P.W. board ass'y
3. Indicators (meters)
4. Main amp. P.W. board ass'y
5. LED P.W. board ass'y
6. E.C. microphone
7. Connector board
8. Speakers (woofers)
9. M.M.S. P.W. board ass'y
10. Jack P.W. board
11. Capstan motor
12. Mecha. control P.W. board ass'y
13. Pre-amp. P.W. board ass'y
14. Phones (headphone) P.W. board
15. Tuner P.W. board ass'y
16. Bar antenna ass'y

## Removal of the Main Parts

### A. Rear cabinet and rod antennas (Fig. 5)

1. Remove the battery cover.
2. Remove 3 screws ① – SBSF4018R.
3. Remove 7 special screws ② – VKZ4008-002.  
To remove the rear cabinet, remove the rod antennas and power supply P.W. board wires connector.
4. To remove the rod antenna only, remove a screw ③ fixing the antenna holder (need not the rear cabinet).

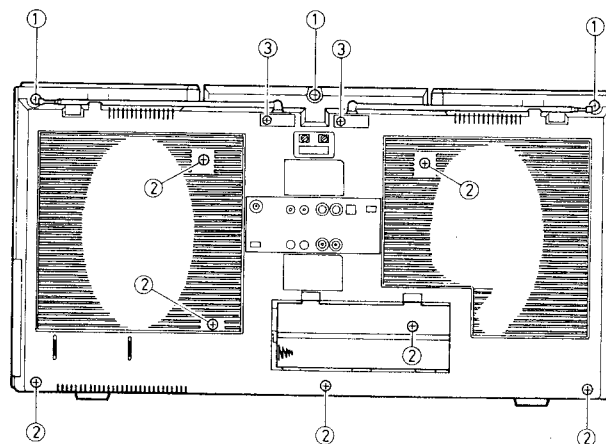

Fig. 5

### B. Chassis (with cassette mechanical unit) (Fig. 6, 7)

1. Remove 2 screws ④ – SDSP3008RS (upper side on the front cabinet) and 2 screws ⑤ – SBSF3012R (lower side on the front cabinet).
2. Remove 7 screws ⑥ – SBSF3014C, and a screw – SBSF3030V.
3. Remove 8 connectors ① ~ ⑧.
4. Remove lever switch knobs, VR knobs and tuning knob.

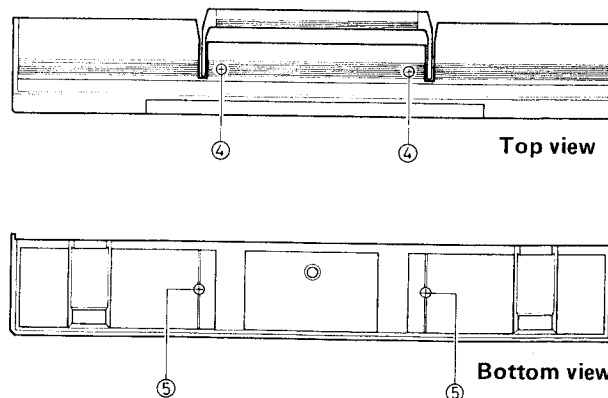

Fig. 6

**C. Mechanical unit (Fig. 8)**

1. Remove 4 screws (7) – SBSF3010V.
2. Remove a wire connector (1).
3. Unsolder head wires.

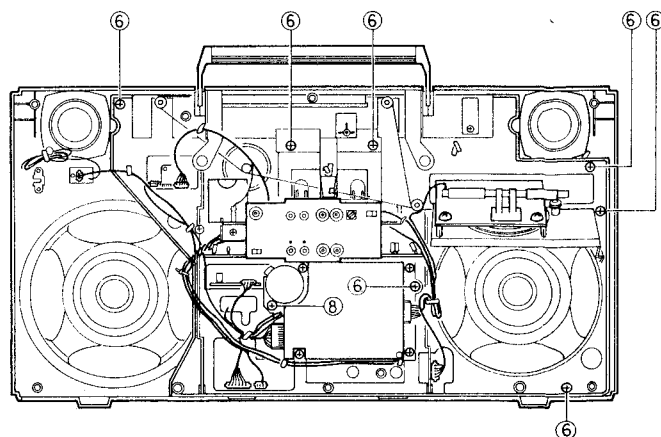

Fig. 7

**D. Mechanical unit (How to remove directly from the front cabinet) (Fig. 7, 8)**

1. Remove 4 screws (7) – SBSF3010V.
2. Remove a screw (8) – SBSF3030V.
3. Remove wire connectors (B), (D) ~ (F) and (I).
4. Unsolder head wires.

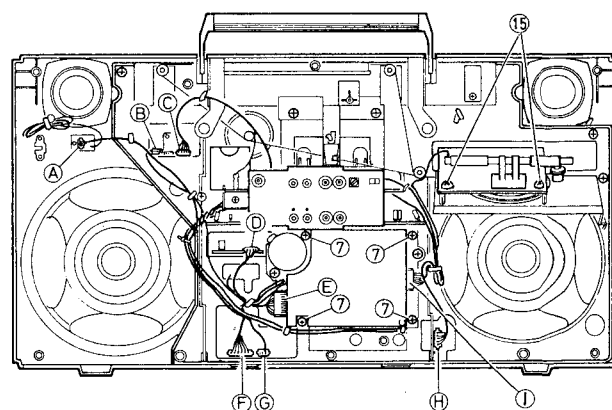

Fig. 8

**E. Other parts (Fig. 8, 9)**

1. Tweeters = remove 4 screws (9) – SBSF3008Z.
2. Woofers = remove 8 screws (10) – SBSF4010Z.
3. Connector P.W. boards and power switch P.W. board = remove 7 screws (11) – SBSF3010Z.
4. MMS jack and phones P.W. boards = remove 4 screws (12) – SBSF3008Z.
5. Mechanical operation button P.W. board = remove 2 screws (13) – SBSF2616Z.
6. Pre-amp. and main amp. P.W. board = remove 2 screws (14) – SBSF3012V.
7. Tuner P.W. board = remove 2 screws (15) – SBSF3012V.

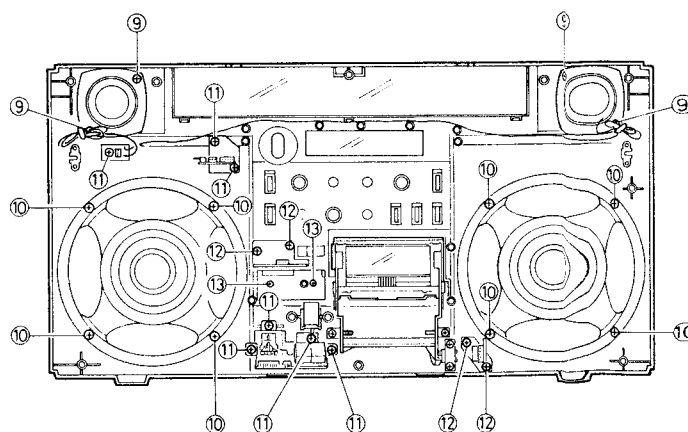

Fig. 9

# Removal of the Mechanical Parts

(Refer to page 26 "Cassette Mechanical Component Parts".)

## A. Pinch roller arm ass'y (96) (Fig. 10)

1. Remove E-ring (98).
2. Remove the pinch roller arm ass'y with its spring.

## B. Heads (Fig. 10)

1. REC/PB head (45)  
Unsolder the head wires and remove 2 screws (49).
2. Erase head (47)  
Unsolder the head wires and remove 2 screws (51).

## C. Cassette plate (Fig. 10)

1. Remove 2 screws – SDSB2605R.
2. To remove the cassette plate, hold upper side on the (A) and (B) points.

## D. Tape counter (60) (Fig. 10)

1. Remove the counter belt (124).
2. Draw the counter ass'y to front side, pushing the mold part of the bracket lower side by screw driver.

## E. Reel disk ass'y (Fig. 10)

1. Take-up reel disk ass'y (4)  
Remove the cassette plate and the counter belt (124).  
Remove the reel stopper (7).
2. Supply reel disk ass'y (5)  
Remove the reel stopper (7).  
When assembling the reel disk, the stopper need a new part, the stopper cannot be used again.

## F. Mecha. control P.W. board ass'y (Fig. 11)

Remove 4 screws (142).

## G. Flywheel holder (125) (Fig. 12)

Remove 3 screws (127).

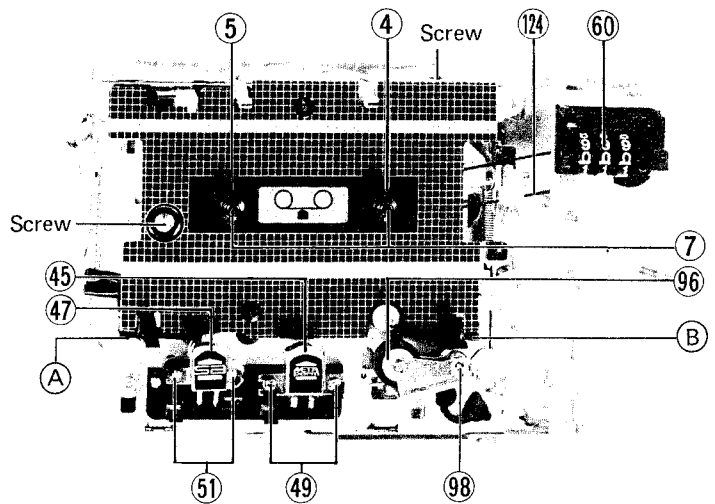

Fig. 10

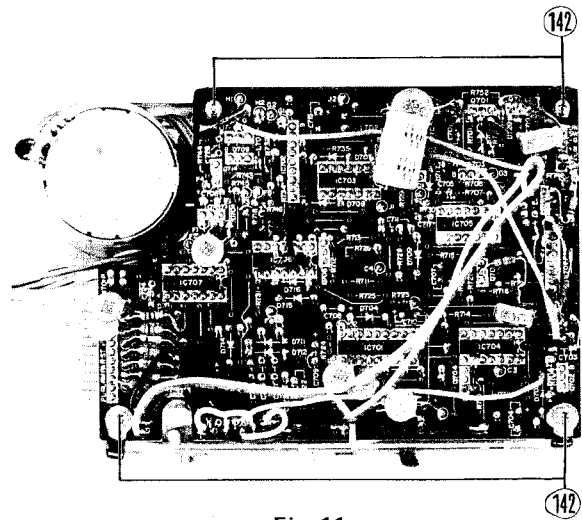

Fig. 11

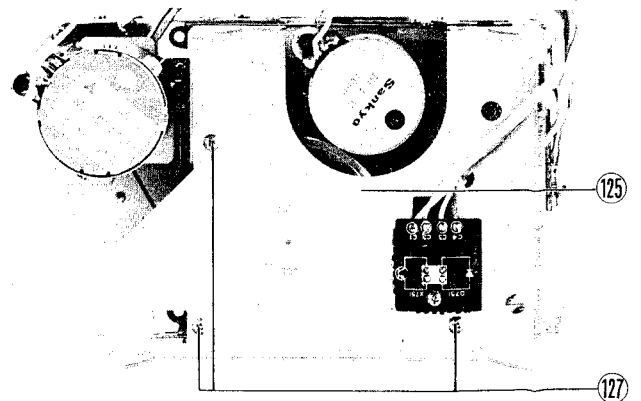

Fig. 12

**H. Capstan motor 53** (Fig. 13)

1. Remove the capstan belt 122 .
2. Remove 3 screws 61 with motor bracket.
3. Remove the rubber stopper, and then turn the motor to inside.

**I. Reel motor 73** (Fig. 13)

Remove 2 screws 76 .

**J. Flywheel ass'y 117** (Fig. 13)

Remove the take-up belt and capstan belt.  
(When replacing the flywheel, be sure to employ washers.  
Be careful not to soil the belt.)

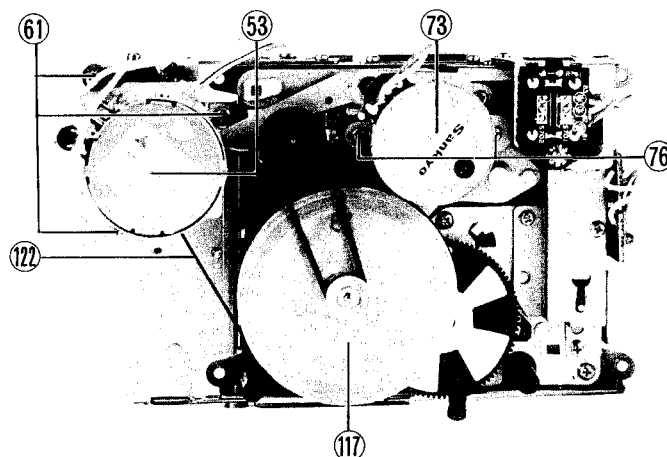

Fig. 13

**K. Reel disk ass'y 2** (Fig. 14)

1. Remove the reel motor, flywheel ass'y and counter belt.
2. Remove 3 screws 77 .

**L. Drive gear ass'y 16** (Fig. 14)

1. Remove the flywheel ass'y.
2. Remove 3 screws 86 .

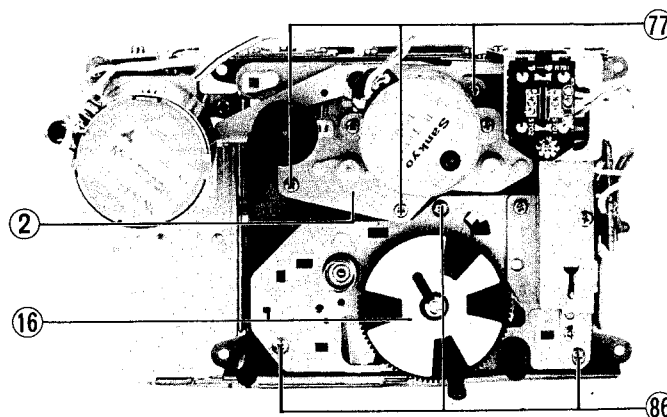

Fig. 14

## How to Engage Dial Cord

1. Turn the dial drum fully counterclockwise (to the lowest frequency).
2. Use Kevlar cord (1,680 mm long and 0.5 mm in diameter).
3. Install the string in the sequence of the numbers.
4. Wind 2 turns to the tuning shaft and the drum.

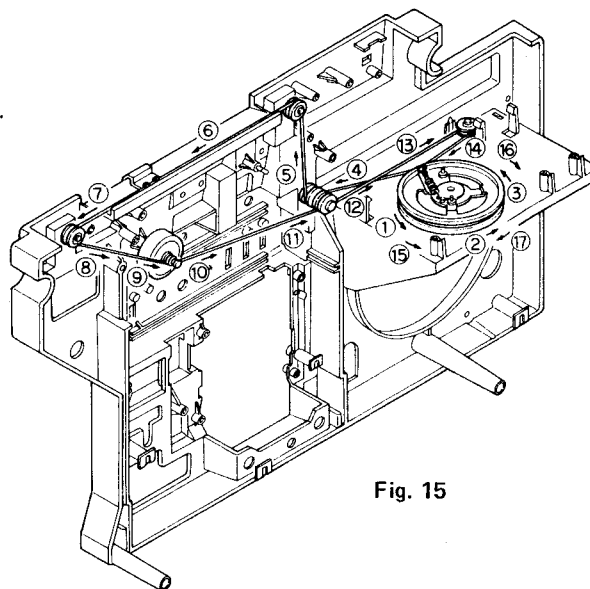

Fig. 15

## Safety Precautions

**⚠ Safety mark**

Safety is very important with this unit. When replacing the parts marked **⚠**, be sure to use only those designated parts. The designated resistors, diodes, transistors become hot in use. When replacing, be sure to secure them with a distance of more than 5 mm from the circuit board. In addition, they are banded together to avoid touching other wiring, recheck this point as well after repair.

The wiring of the primary side should be wound more than one and half times, then soldered.

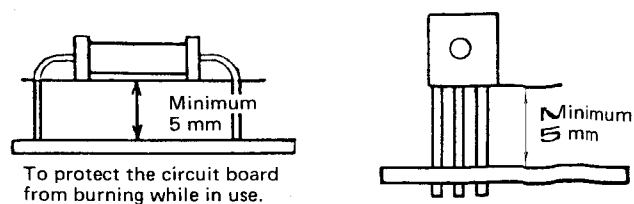

To protect the circuit board from burning while in use.

Fig. 16

N o. 1462

# Tuner Alignment

Output Measuring: Speaker terminal (Impedance = 6 Ω), output level 50 mW (0.55 V/6 Ω)

## AM IF & RF Alignment

Input (SSG) Modulation 400 Hz, Modulated to 30%

Step	Frequency Band	Input Signal		Place to be aligned	Set the V. Capacitor to
		Frequency	Given to		
1	AM (IF)	455 kHz	Loop Antenna	T3, 4, 5 (Input ; TP-3 Output; TP-4, TP-5)	Minimum
2		Repeat the Step 1, and adjust for no further improvement.			
3	AM	520 kHz	Loop Antenna	L8	Maximum
4		1650 kHz		TC8	Minimum
5		Repeat the Steps 3 & 4.			
6		620 kHz	Loop Antenna	L1	620 kHz Signal
7		1400 kHz		TC1	1400 kHz Signal
8		Repeat the Steps 6 & 7, and adjust for no further improvement.			
9	SW1	1.55 MHz	Loop Antenna	L9	Maximum
10		3.7 MHz		TC9	Minimum
11		Repeat the Steps 9 & 10.			
12		1.6 MHz	Loop Antenna	L2	1.6 MHz Signal
13		3.5 MHz		TC2	3.5 MHz Signal
14		Repeat the Steps 12 & 13, and adjust for no further improvement.			
15	SW2	3.4 MHz	Rod Antenna thorough Dummy Antenna	L10	Maximum
16		6.3 MHz		TC10	Minimum
17		Repeat the Steps 15 & 16.			
18		3.5 MHz	Rod Antenna through Dummy Antenna	L3	3.5 MHz Signal
19		6.0 MHz		TC3	6.0 MHz Signal
20		Repeat the Steps 18 & 19, and adjust for no further improvement.			
21	SW3	5.9 MHz	Rod Antenna through Dummy Antenna	L11	Maximum
22		6.3 MHz		TC11	Minimum
23		Repeat the Steps 21 & 22.			
24		5.9 MHz	Rod Antenna through Dummy Antenna	L4	5.9 MHz Signal
25		6.3 MHz		TC4	6.3 MHz Signal
26		Repeat the Steps 24 & 25, and adjust for no further improvement.			
27	SW4	5.8 MHz	Rod Antenna through Dummy Antenna	L12	Maximum
28		11.5 MHz		TC12	Minimum
29		Repeat the Steps 27 & 28.			
30		6.0 MHz	Rod Antenna through Dummy Antenna	L5	6.0 MHz Signal
31		11.0 MHz		TC5	11.0 MHz Signal
32		Repeat the Steps 30 & 31, and adjust for no further improvement.			
33	SW5	10.7 MHz	Rod Antenna through Dummy Antenna	L13	Maximum
34		19.0 MHz		TC13	Minimum
35		Repeat the Steps 33 & 34.			
36		12.0 MHz	Rod Antenna through Dummy Antenna	L6	12.0 MHz Signal
37		18.0 MHz		TC6	18.0 MHz Signal
38		Repeat the Steps 36 & 37, and adjust for no further improvement.			



Step	Frequency Band	Input Signal		Place to be aligned	Set the V. Capacitor to	
		Frequency	Given to			
39	SW6	18.0 MHz	Rod Antenna through Dummy Antenna	L14	Maximum	
40		27.5 MHz		TC14	Minimum	
41		Repeat the Steps 39 & 40.				
42		19.0 MHz	Rod Antenna through Dummy Antenna	L7	19.0 MHz Signal	
43		26.0 MHz		TC7	26.0 MHz Signal	
44		Repeat the Steps 42 & 43, and adjust for no further improvement.				

**FM IF & Discriminator Alignment**

Input (Sweep Generator) : TP1 (hot)  
 Output (Oscilloscope) : IF TP2 (hot) & TP5  
 Discriminator TP2 (hot) & TP5

Step	Mode	Place to be aligned	Wave form
1	IF	T1	Fig. A
2	Discriminator	T2	Fig. B

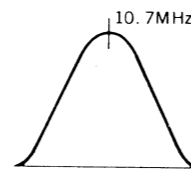
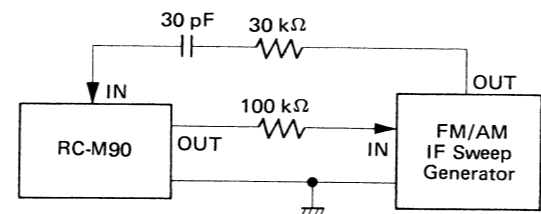

Fig. A

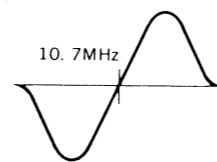

Fig. B

**FM RF Alignment**

Input (SSG): Use 75 Ω terminal, modulation 400 Hz modulated to 22.5 kHz deviation. Connect Hot side to TP6 and Cold side to TP7.

Step	Frequency Band	Input Signal		Place to be aligned	Set the V. Capacitor to	
		Frequency	Given to			
1	FM	87.5 MHz	TP6 & TP7	L16	Maximum	
2		109 MHz		TC16	Minimum	
3		Repeat the Steps 1 & 2.				
4		90 MHz	TP6 & TP7	L15	90 MHz Signal	
5		106 MHz		TC15	106 MHz Signal	
6		Repeat the Steps 4 & 5, and adjust for no further improvement.				

**FM MPX Alignment**

**A. 19 kHz Alignment (regular Method)**

1. Connect a frequency counter to the test point TP8.
2. Adjust the variable resistor VR1 so that the frequency becomes 19 kHz ± 250 Hz.

**B. 19 kHz Alignment (Simplified Method)**

1. Turn to an FM stereo broadcast.
2. Set the variable resistor VR1 to the center position of the range in where the stereo indicator keeps lighting.

**C. Separation Alignment**

1. Connect an FM stereo signal generator across the test points TP2 (98 MHz, 60 dB).
2. Connect an Electronic voltmeter or oscilloscope across the test points TP8.
3. Adjust the variable resistor VR2 to minimize the output of right channel signal.

**Parts Arrangement for Alignment**

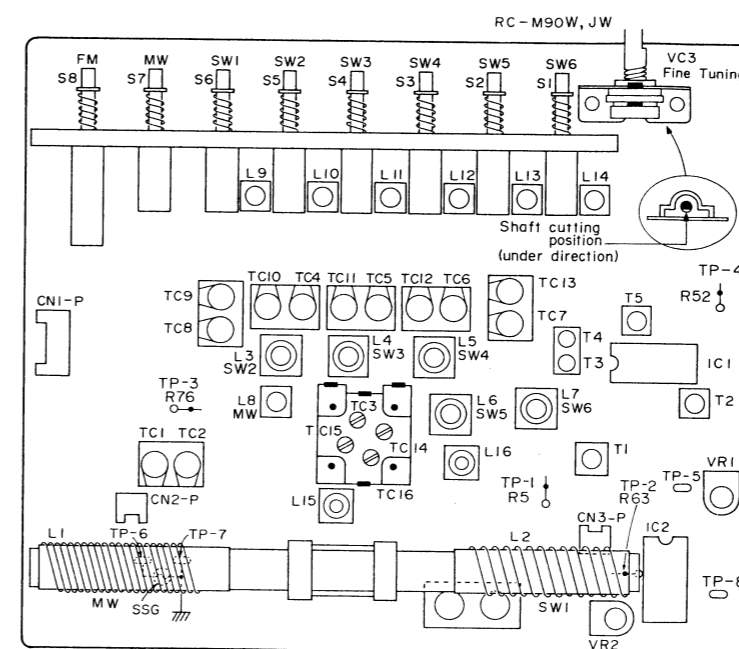
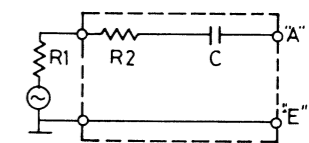

Fig. 17

**Dummy Antenna**



$R1 + R2 = 80 \Omega$

$C = 10 \text{ pF}$

R1 : Output impedance of S.S.G.



# Block Diagrams

## A. Tuner Circuit

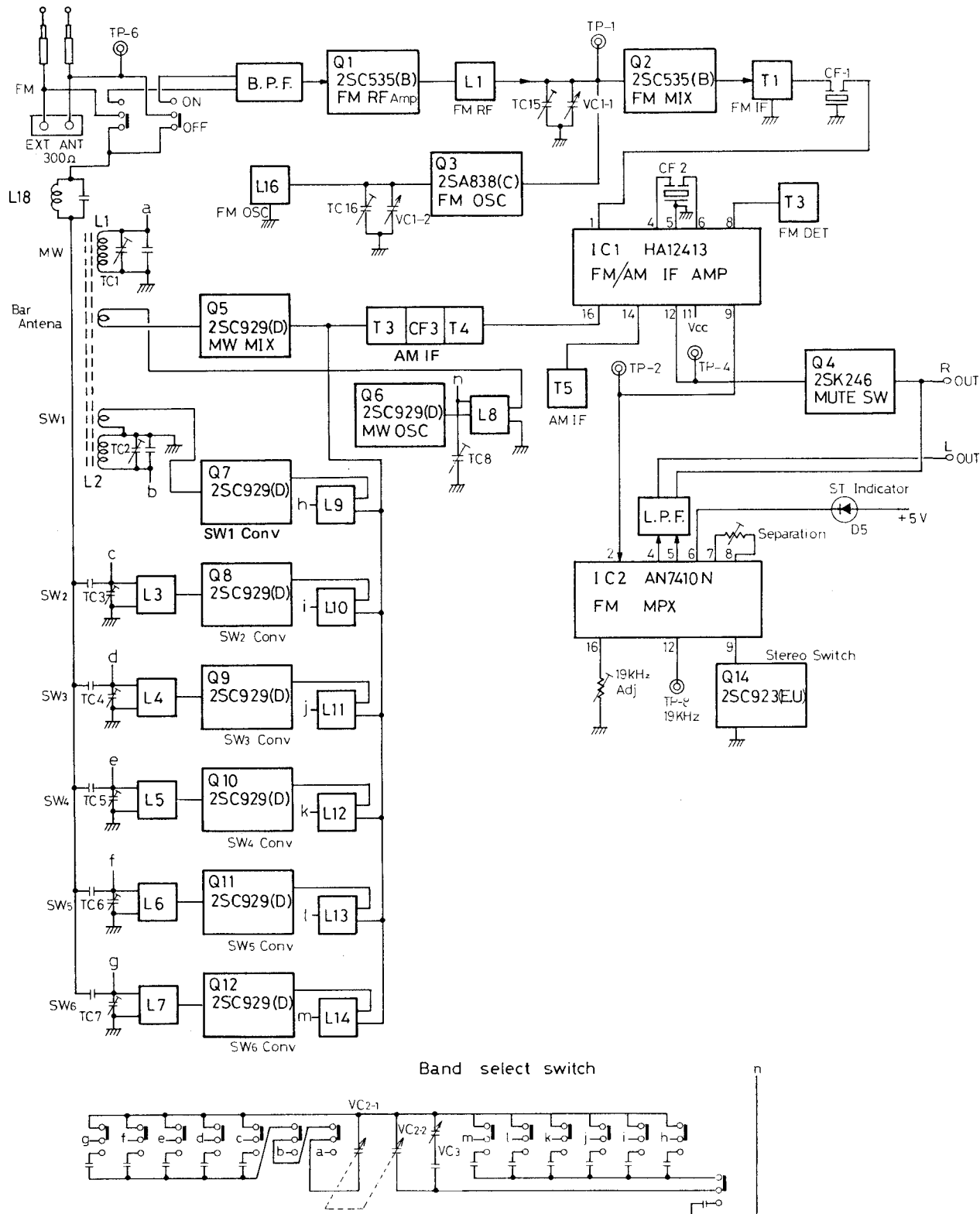

Fig. 19

**B. Pre-Amplifier Circuit**

**At recording**

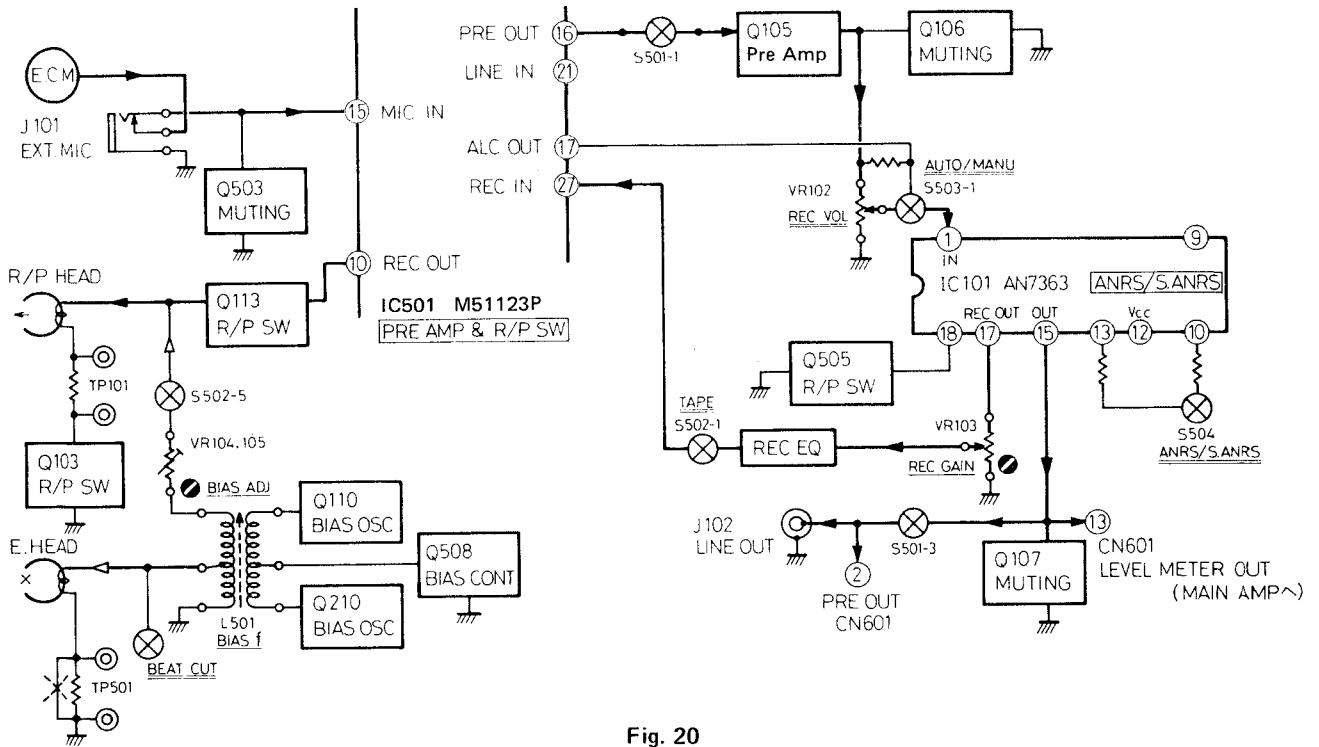

Fig. 20

**At playback**

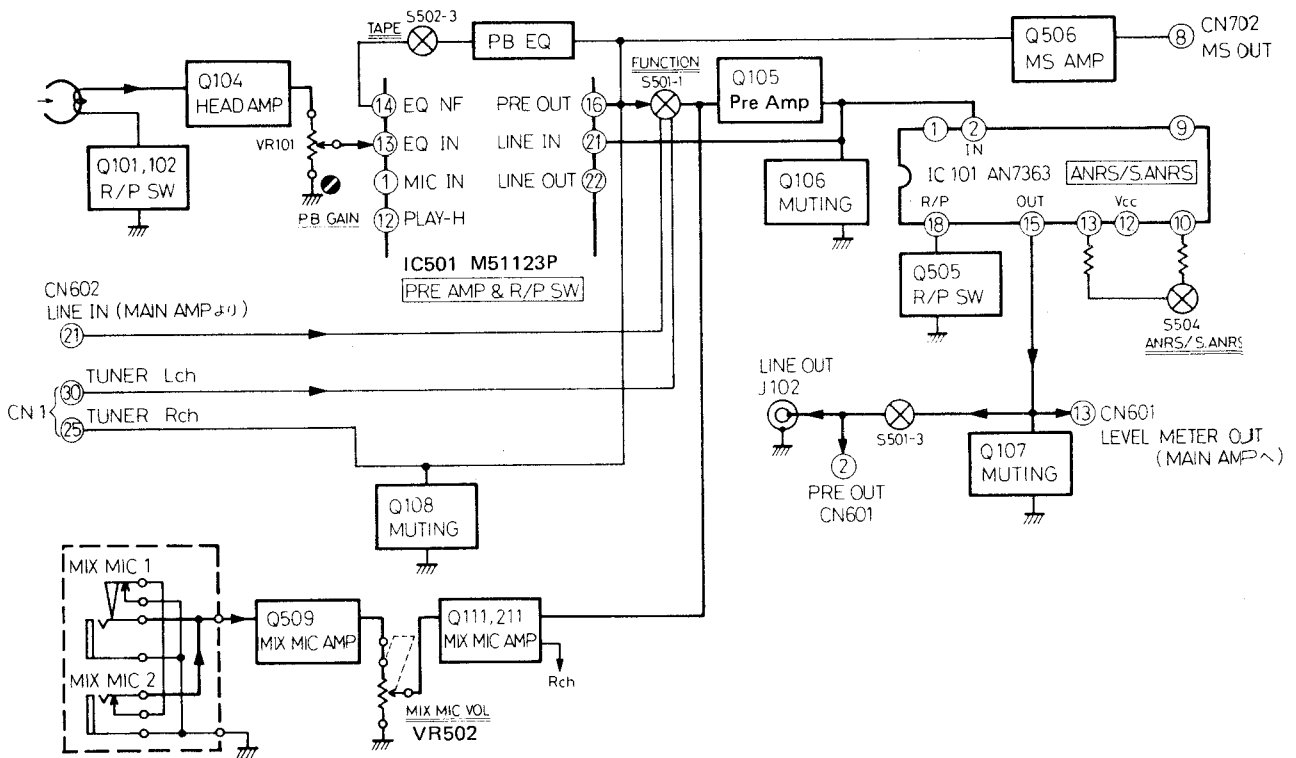

Fig. 21

C. Main Amplifier Circuit

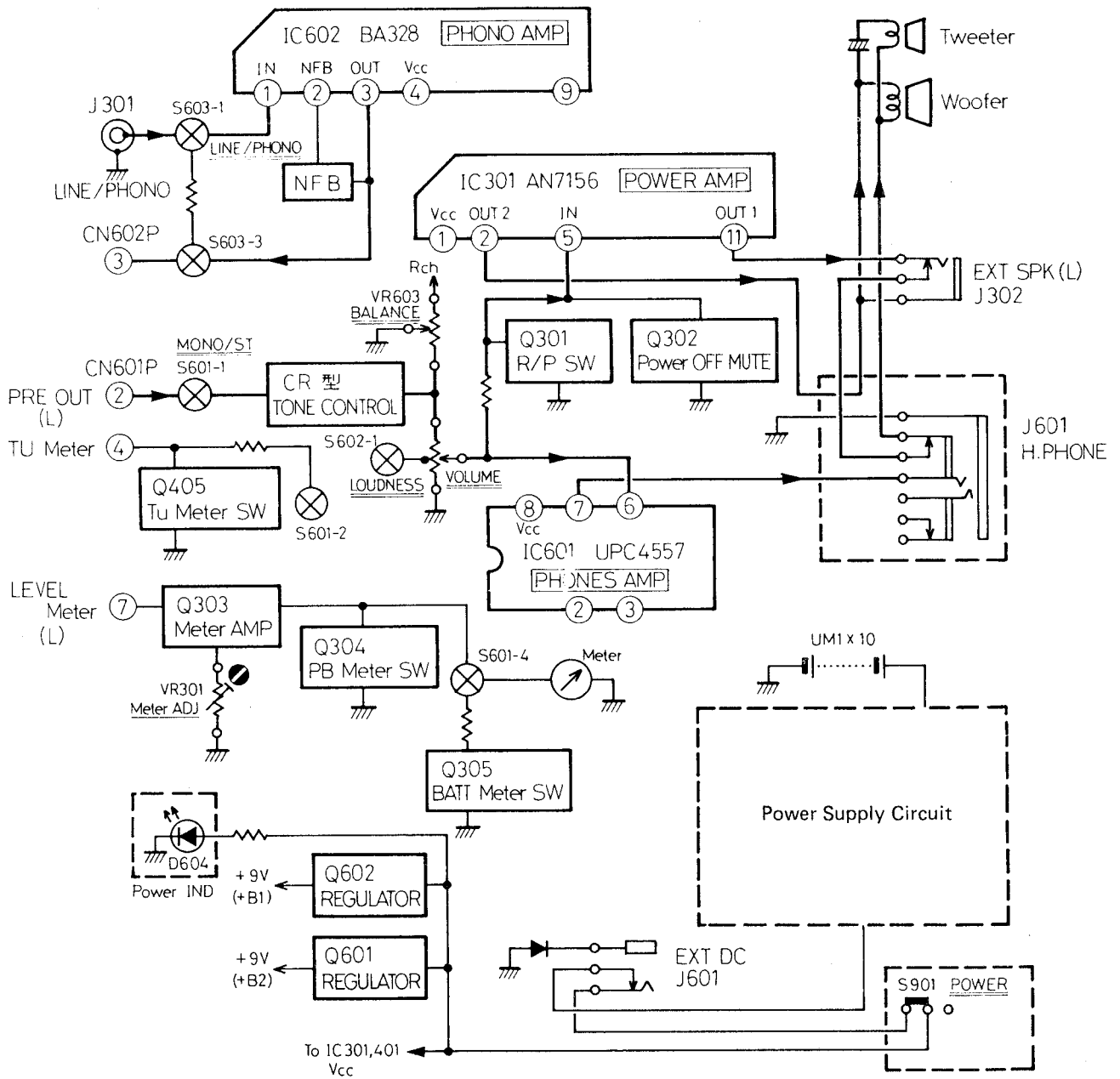

Fig. 22

D. Mecha. Control Circuit

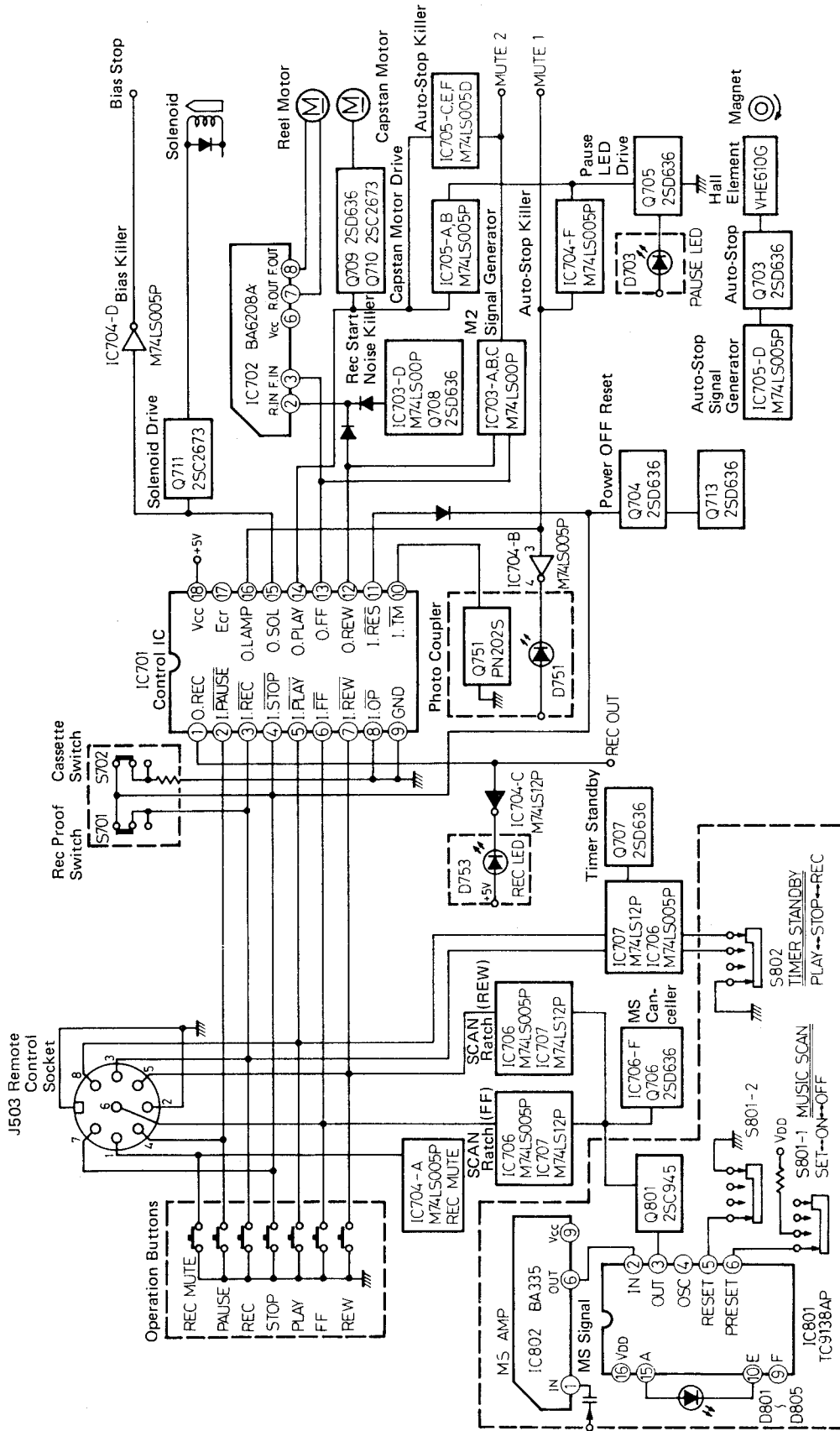
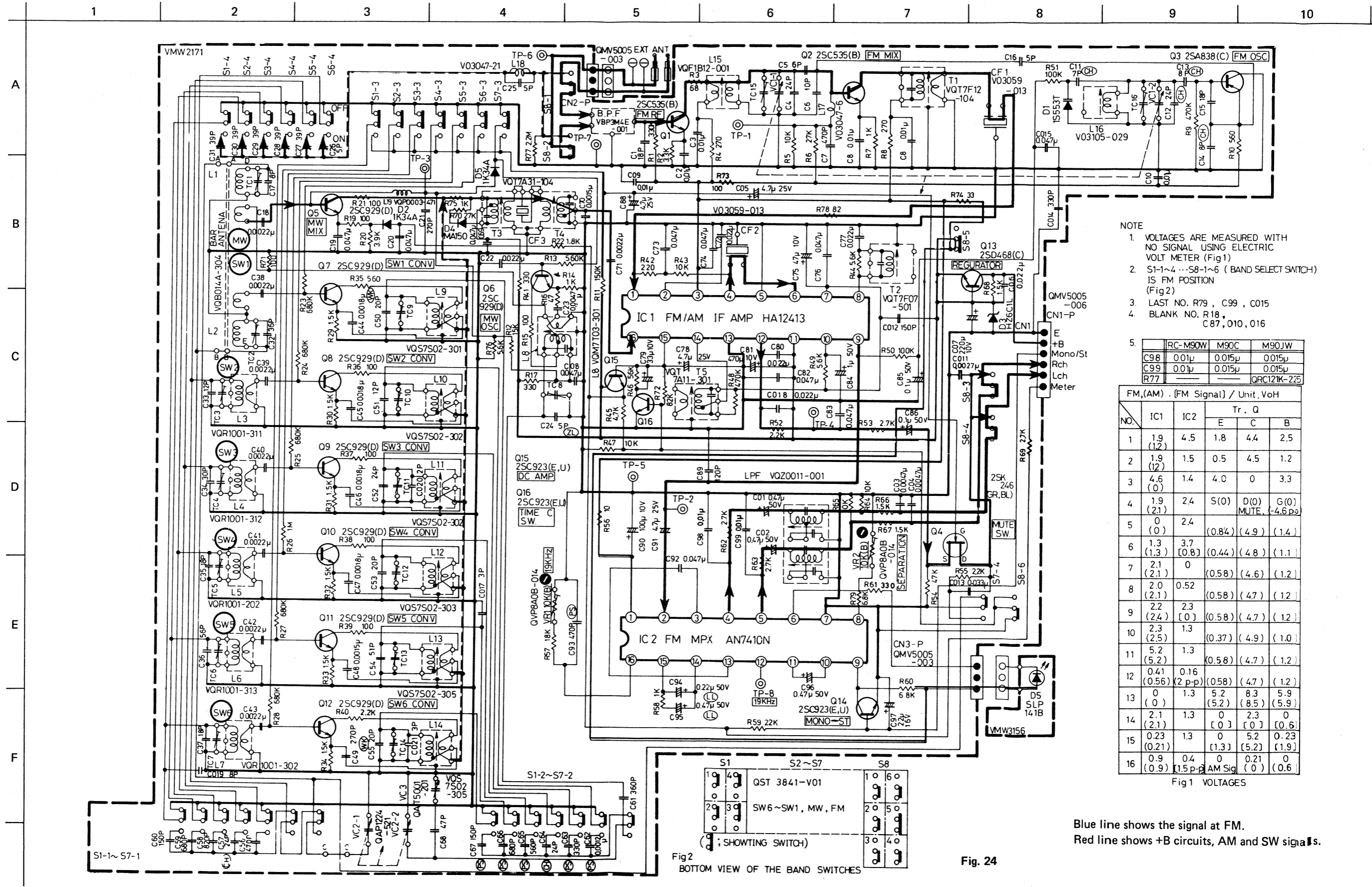

Fig. 23

# Standard Schematic Diagram of RC-M90 (Tuner Circuit)



- NOTE
- VOLTAGES ARE MEASURED WITH NO SIGNAL USING ELECTRIC VOLT METER (Fig1)
  - S1-1~4 ... S8-1~6 ( BAND SELECT SWITCH) IS FM POSITION (Fig2)
  - LAST NO. R79, C99, C015
  - BLANK NO. R18, C87, C010, C016

	RC-M90W	M90C	M90JW
C98	0.01 $\mu$	0.015 $\mu$	0.015 $\mu$
C99	0.01 $\mu$	0.015 $\mu$	0.015 $\mu$
R77			QR121K-225

NO.	IC1	IC2	Tr. Q		
			E	C	B
1	1.9 (1.2)	4.5	1.8	4.4	2.5
2	1.9 (1.2)	1.5	0.5	4.5	1.2
3	4.6 (0)	1.4	4.0	0	3.3
4	1.9 (2.1)	2.4	S(0)	D(0)	G(0)
5	0 (0)	2.4	(0.84)	(4.9)	(1.4)
6	1.3 (1.3)	3.7 (0.8)	(0.44)	(4.8)	(1.1)
7	2.1 (2.1)	0	(0.58)	(4.6)	(1.2)
8	2.0 (2.1)	0.52	(0.58)	(4.7)	(1.2)
9	2.2 (2.4)	2.3 (0)	(0.58)	(4.7)	(1.2)
10	2.3 (2.5)	1.3	(0.37)	(4.9)	(1.0)
11	5.2 (5.2)	1.3	(0.58)	(4.7)	(1.2)
12	0.41 (0.56)	0.16 (2 p-p)	(0.58)	(4.7)	(1.2)
13	0 (0)	1.3	5.2 (5.2)	8.3 (8.5)	5.9 (5.9)
14	2.1 (2.1)	1.3 (0)	0 (0)	2.3 (0)	0 (0.6)
15	0.23 (0.21)	1.3 (1.3)	5.2 (5.2)	0.23 (1.9)	
16	0.9 (0.9)	0.4 (1.5 p-p)	0 (AM Sig)	0.21 (0)	0 (0.6)

Fig1 VOLTAGES

Blue line shows the signal at FM.  
Red line shows +B circuits, AM and SW signals.

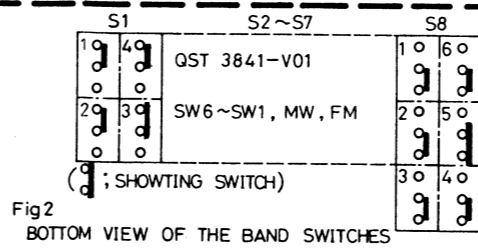
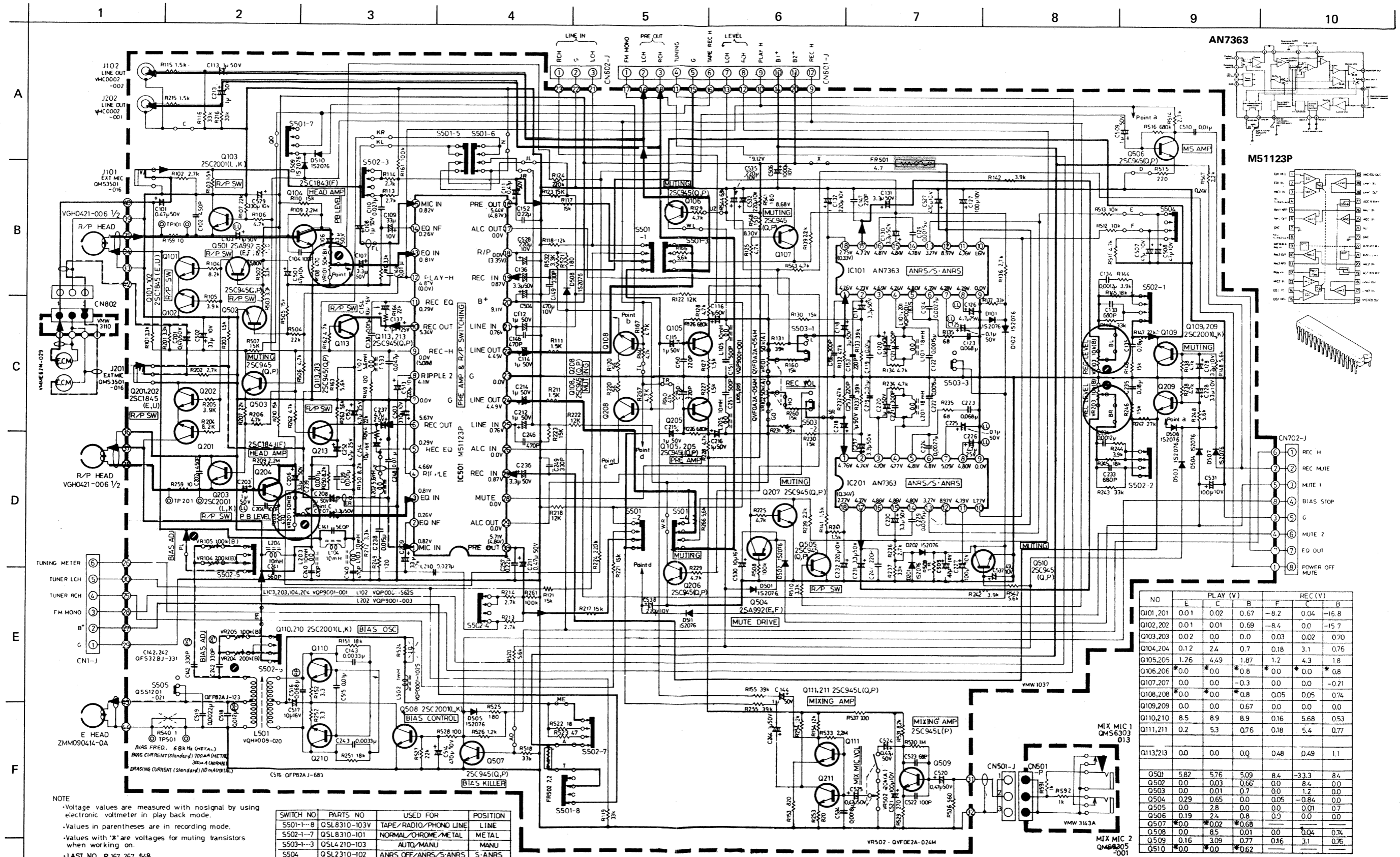

Fig2 BOTTOM VIEW OF THE BAND SWITCHES

Fig. 24

# Standard Schematic Diagram of RC-M90 (Pre-Amp Circuit)



**NOTE**

- Voltage values are measured with signal by using electronic voltmeter in playback mode.
- Values in parentheses are in recording mode.
- Values with \* are voltages for muting transistors when working on
- LAST NO. R 167, 267, 548, C 157, 257, 538, Q 113, 213, 510.
- BLANK NO. R 156, 157, 158, 165, 256, 257, 258, 265, 534, 535, 538, 539, 545, C 105, 145, 155, 205, 245, 255, 256, 511, 512, 526, 536, Q 112, 212

NO	PLAY (V)			REC (V)		
	E	C	B	E	C	B
Q101,201	0.01	0.02	0.67	-8.2	0.04	-16.8
Q102,202	0.01	0.01	0.69	-8.4	0.0	-15.7
Q103,203	0.02	0.0	0.0	0.03	0.02	0.70
Q104,204	0.12	2.4	0.7	0.18	3.1	0.76
Q105,205	1.26	4.49	1.87	1.2	4.3	1.8
Q106,206	*0.0	*0.0	*0.8	*0.0	*0.0	*0.8
Q107,207	0.0	0.0	-0.3	0.0	0.0	-0.21
Q108,208	*0.0	*0.0	*0.8	0.05	0.05	0.74
Q109,209	0.0	0.0	0.67	0.0	0.0	0.0
Q110,210	8.5	8.9	8.9	0.16	5.68	0.53
Q111,211	0.2	5.3	0.76	0.18	5.4	0.77
Q113,213	0.0	0.0	0.0	0.48	0.49	1.1
Q501	5.82	5.76	5.09	8.4	-33.3	8.4
Q502	0.0	0.03	0.66	0.0	8.4	0.0
Q503	0.0	0.01	0.7	0.0	1.2	0.0
Q504	0.29	0.65	0.0	0.05	-0.84	0.0
Q505	0.0	2.8	0.0	0.0	0.01	0.7
Q506	0.19	2.4	0.8	0.2	0.0	0.0
Q507	*0.0	*0.02	*0.68			
Q508	0.0	8.5	0.01	0.0	0.04	0.74
Q509	0.16	3.09	0.77	0.16	3.1	0.76
Q510	*0.0	*0.0	*0.62			

Fig. 25

No. 1462

Blue line shows the signal at playback.  
 Red line shows the signal at recording and +B circuits.  
 [Symbol] parts are safety assurance parts.  
 When replacing those parts, make sure to use the specified one.



# Standard Schematic Diagram of RC-M90 (Main Amp Circuit)

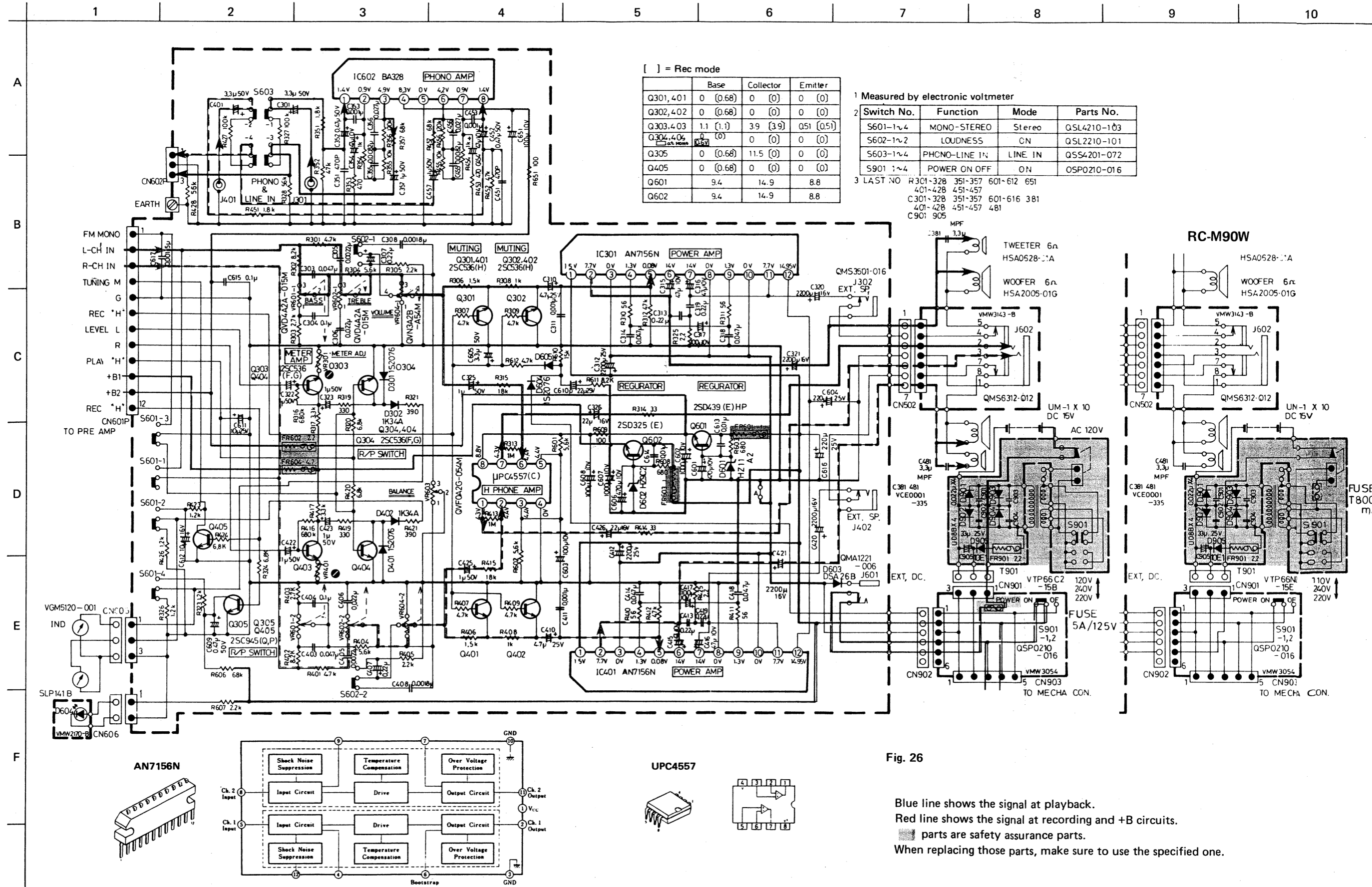

# Standard Schematic Diagram of RC-M90 (Mecha. Control Circuit)

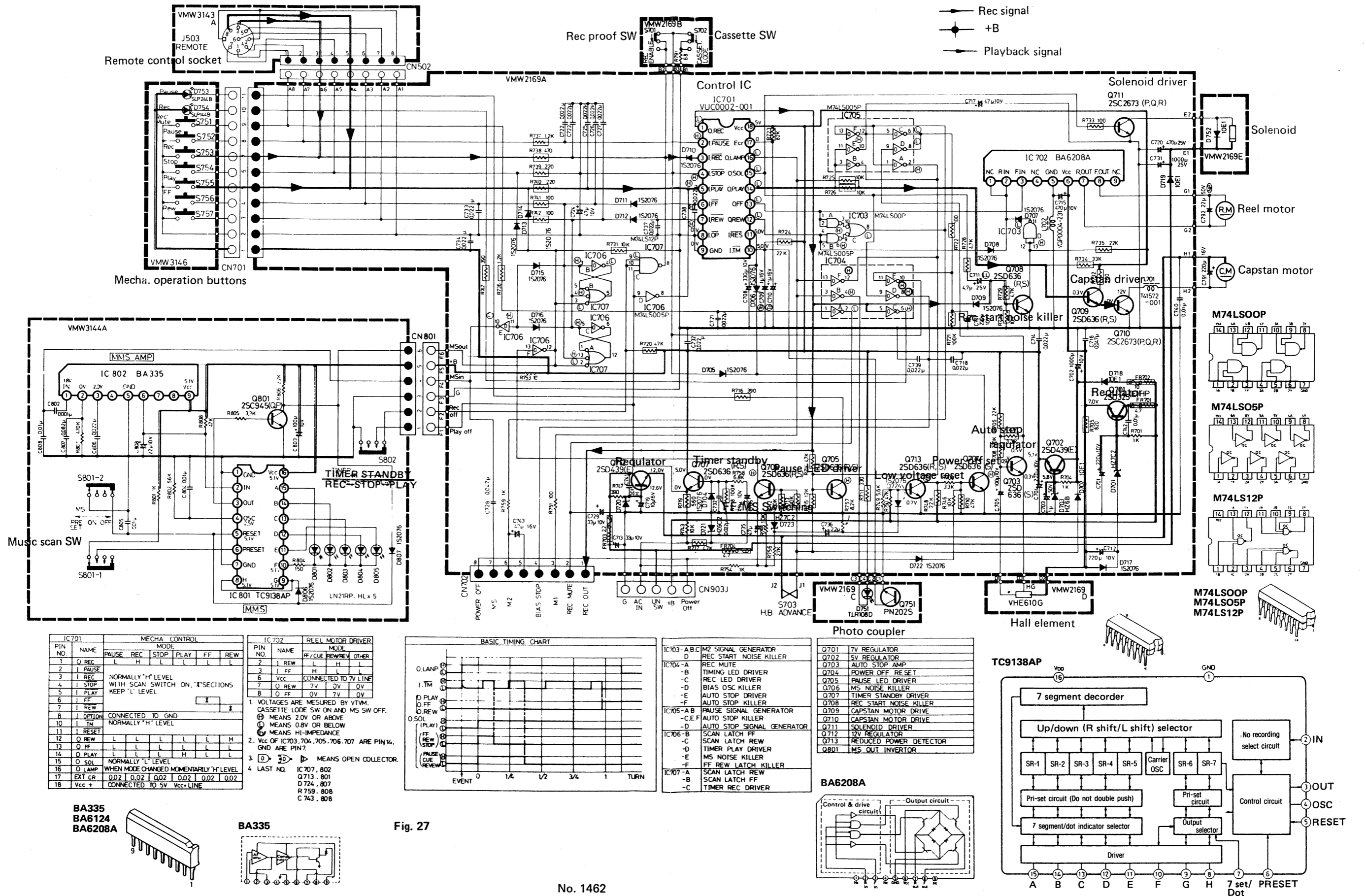

# Wiring Connection of RC-M90 (1)

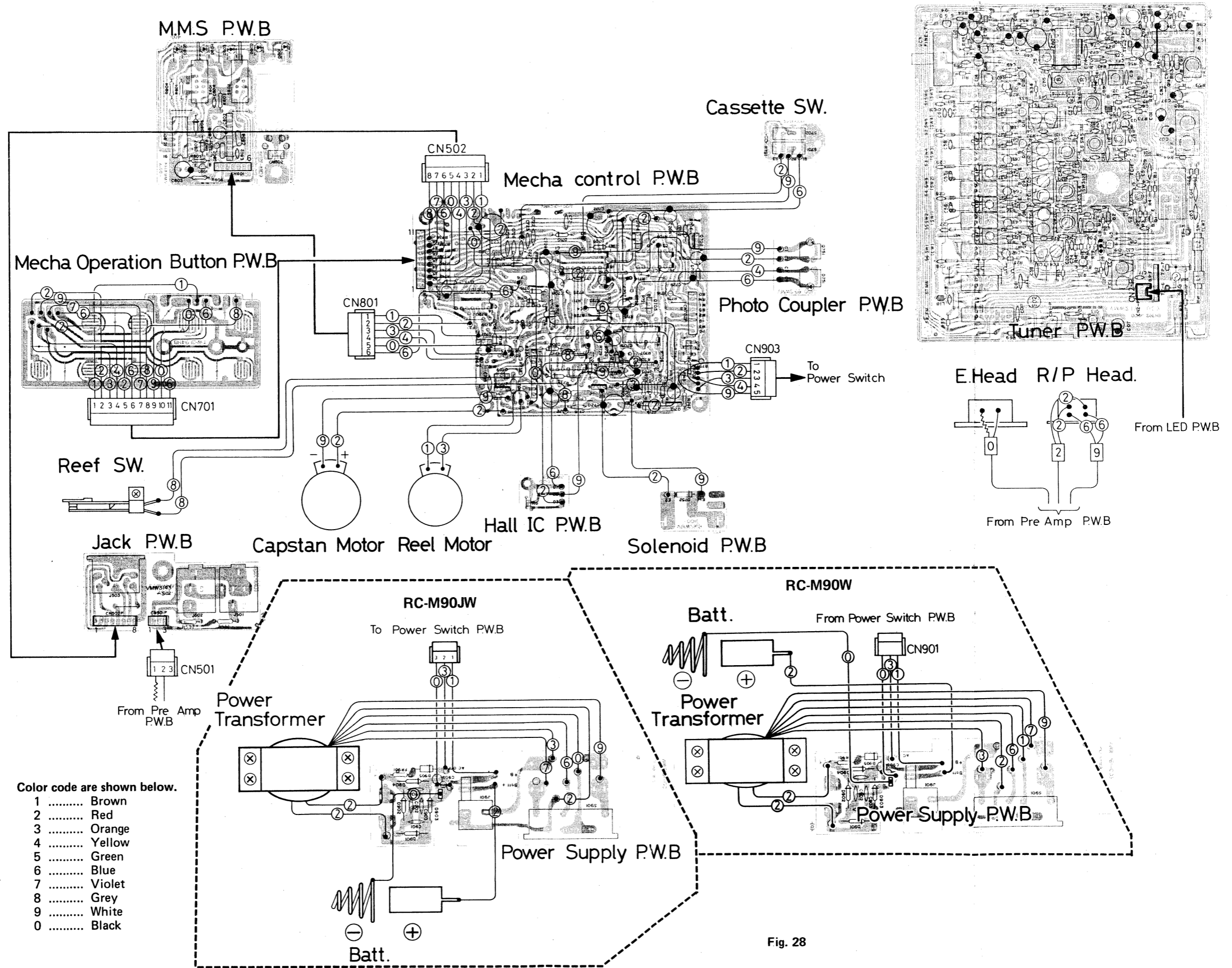

Fig. 28



# Rear Cabinet Parts

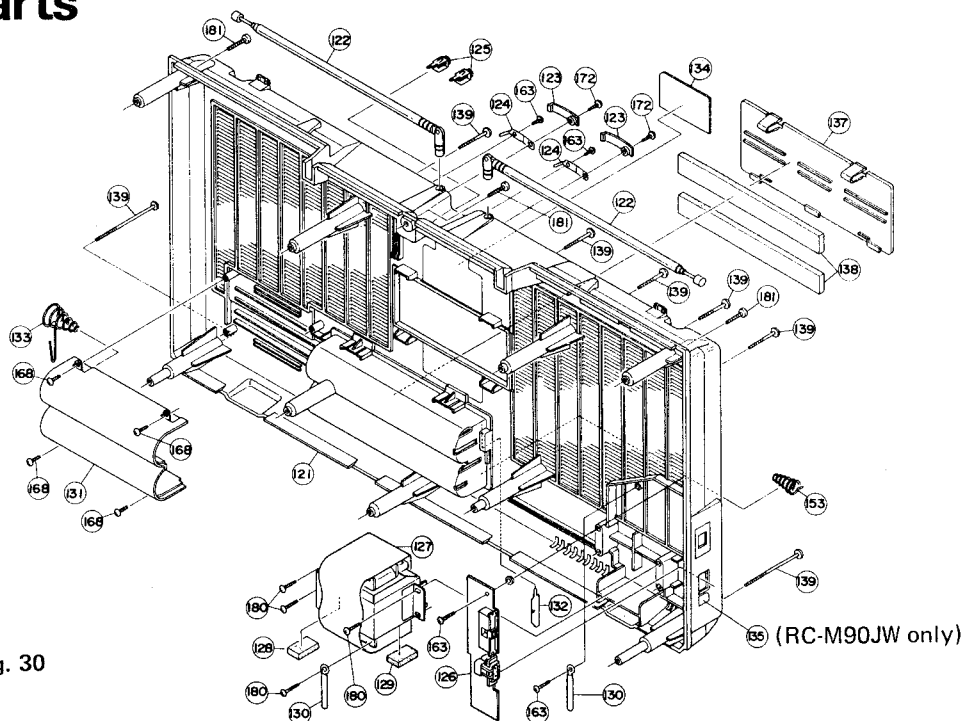

Fig. 30

## Rear Cabinet Parts List

Ref. No.	⚠	Parts No.	Parts Name	Remarks	Q'ty
121, 134, 135, 121, 134 121		ZCRCM90JW-CBR ZCRCM90W-CBR VJC0002-002UL " -003	Rear Cabinet Ass'y " Rear Cabinet "	RC-M90JW RC-M90W RC-M90JW RC-M90W	1 1 1 1
122		OZR4234-001U	Rod Antenna		2
123		VJD4508-001	Ant. Cover		2
124		VYH4775-001	Rod Ant. Holder		2
125		V44814-00B	Terminal Ass'y		2
126		—	Power Supply P.W.B. Ass'y		1
127	⚠ ⚠	VTP66N2-15C VTP66C2-15B	Power Transformer "	T901, RC-M90W T901, RC-M90JW	1 1
128		VYSR108-005	Spacer		1
129		VYSR105-005	"		1
130		VKZ4001-010	Wire Holder		1
131		VYH3198-001	Batt. Holder		1
132		VYH4010-001	Contact		1
133		VYH4011-001	Battery Spring		1
134		VYN5072-003Q " -002Q	Name Plate "	RC-M90JW RC-M90W	1 1
135		V44852-006	Plate	RC-M90W, -007Q (for PX)	1
136		VNC5005-002	LA Label	RC-M90JW	1
137		VJC3004-003	Batt. Cover		1
138		VYSH106-020	Spacer		2
139		VKZ4008-002	Special Screw		7
158		53738-1	Spring		1
163		SBSF3010Z	Screw	Power P.W.B. — Rear x 1 Rod Ant. Holder x 2	3
168		SBSF3012Z	"	Batt. Holder	4
172		SBSF3012R	"	Rear — Cover	2
180		SBSF4020C	"	Trans. — Rear	4
181		SBSF4018R	"	Rear — Front	3

## Enclosure Assembly and Electrical Parts

Ref. No.	Parts No.	Parts Name	Remarks	Q'ty
1 ~	ZCRCM90JW-CBF	Front Cabinet Ass'y	RC-M90JW	1
1	ZCRCM90W-CBF	"	RC-M90W	1
	VJC0001-002UL	Front Cabinet	RC-M90JW	1
	" -003	"	RC-M90W	1
2	VJD2177-001	Speaker Ring		2
3	VJD3280-001	Punching Panel		2
4	HSA2005-01G	Speaker	Woofers	2
5	VKZ4001-002	Wire Holder		3
6	VJD4502-001	Tweeter Panel		2
7	VJD3281-001	Tweeter Frame		2
8	HSA0628-01A	Speaker	Tweeter	2
9	VCE0001-335	M.P.F. Capacitor	C381, 481 (3.3 $\mu$ F)	2
10	VJD4503-001	Mic Panel		2
11	VMME62N-029	E.C. Mic		2
12	VYH4348-001	Mic Bushing		2
13	VYH4298-001	Holder		2
14	-	Connector P.W.B.		1
15	VJD4504-002	Plate (L)	BAND	1
16	VJD4505-002	Plate (R)	POWER	1
17	VJD3282-001	Side Fitting (L)		1
18	VJD3282-002	Side Fitting (R)		1
19	VJD4506-002	Counter Lens		1
20-1	-	Power Switch P.W.B. Ass'y		1
20	VXP4135-001	Push Knob		1
21	VYH4763-001	SW. Bracket		1
22	VKZ4001-010	Wire Holder		2
23	VYH4764-001	MMS. Bracket		1
23-1	-	MMS. Board P.W.B. Ass'y		1
24	VXQ4045-001	Eject Lever		1
25	VYH4765-001	Socket Bracket		1
26	QMC0888-010	DIN Socket		1
27	-	Socket P.W.B. Ass'y		1
28	VKZ4150-001	Special Nut		1
29	-	Jack P.W.B. Ass'y		1
30	VYH4766-001	Jack Holder		1
31	VKZ4150-001	Special Nut		1
32	VJT3069-00A	Cassette Door Ass'y		1
33	VJT3070-00A	Door Lens Ass'y		1
34	VKW4218-001	Door Spring		1
35	VYH4767-001	Door Holder		2
36	VYH4768-001	Damp Holder		1
37	VYH4769-001	Gear		1
38	VJD3284-002	Button Frame		1
39	VYH3195-001	Rubber		1
40	-	LED P.W.B. Ass'y		1
41	VXP4136-002	Button	FF	1
42	" -003	"	Rec	1
43	" -004	"	Pause	1
44	" -005	"	Rec Mute	1
45	VXP4137-001	"	Stop	1
46	" -002	"	Play	1
47	VXP4136-001	"	Rew.	1
48	VYH4770-001	Cap		9
49	QHX2075-001	Wire Clamp		1
50	VXL4152-001	Tuning Knob		1
51	VXL4153-001	Volume Knob		6
52	VXL4154-001	"	MAIN	1
53	VXQ4046-001	Lever Knob		6
54	VXQ4047-001	"	MMS Meter	2
55	VXL4161-001	Knob	FINE	1

# Enclosure Assembly and Electrical Parts (1)

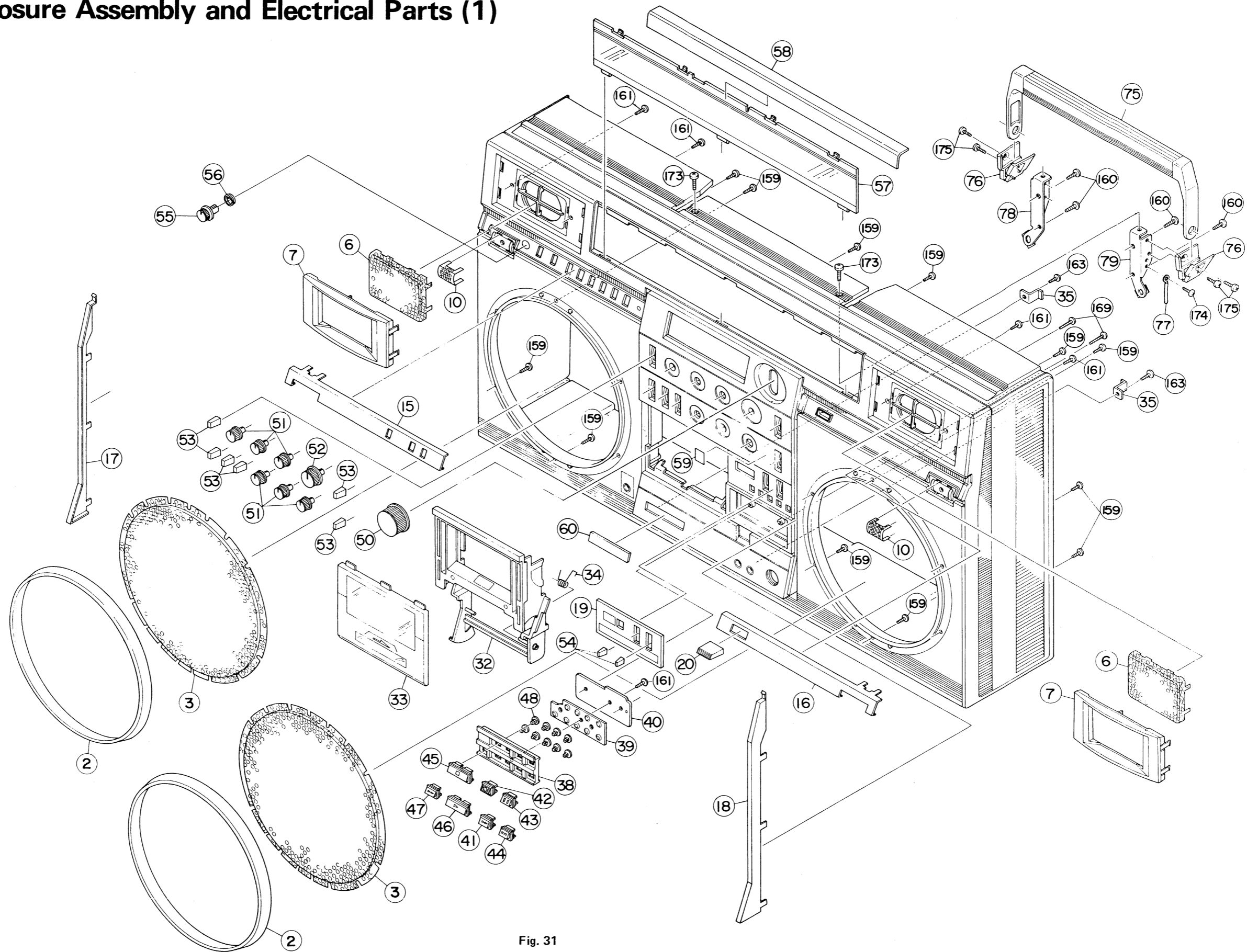

Fig. 31

# Enclosure Assembly and Electrical Parts (2)

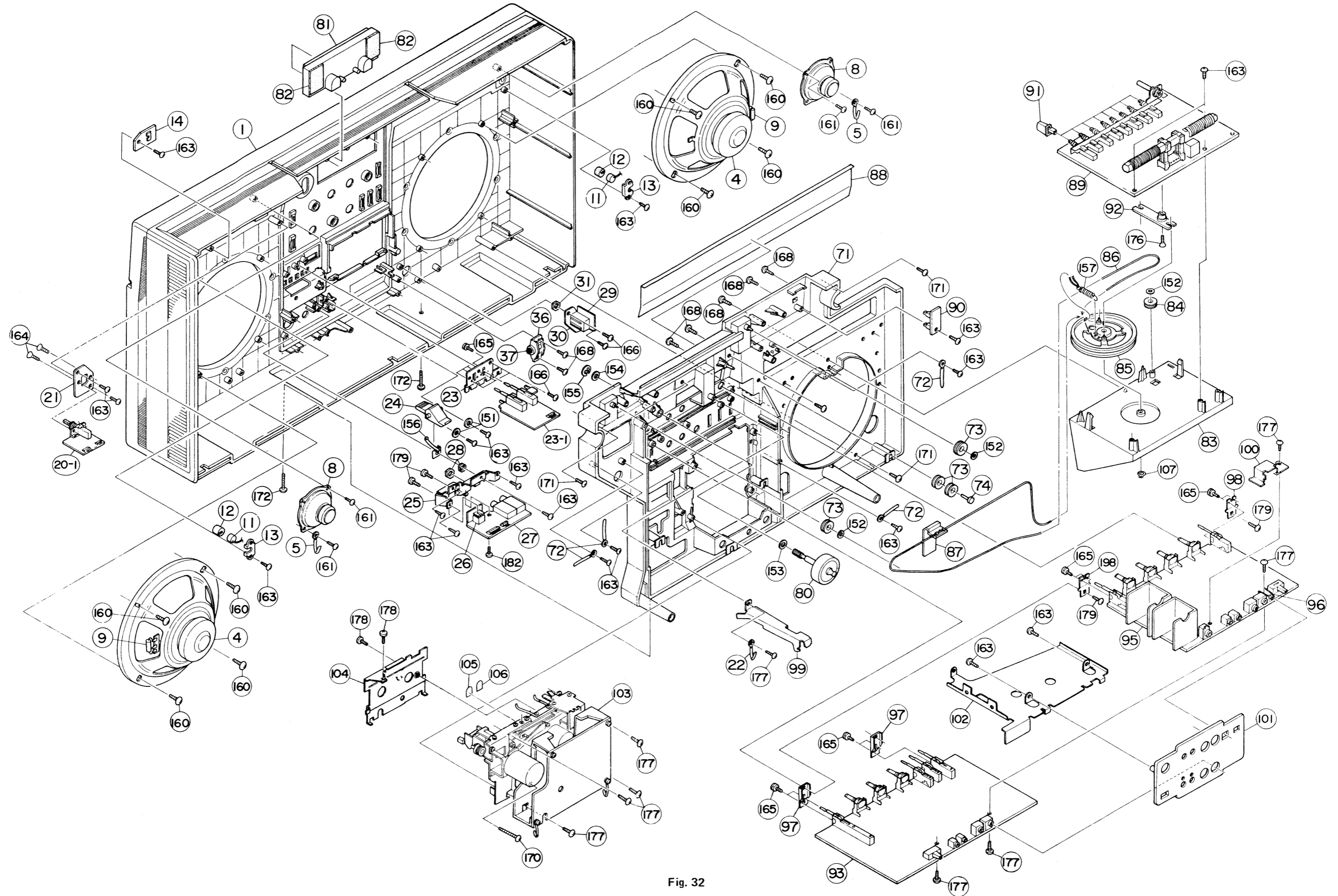

Fig. 32



Ref. No.	Parts No.	Parts Name	Remarks	Q'ty
56	VYH4575-001	Knob Holder		1
57	VJK3178-001	Dial Lens		1
58	VJK4143-001	Lens Plate		1
59	VND4006-010	Caution Label		1
60	QXM2251-001	Mark		1
71	VYH1123-001	Chassis		1
72	VKZ4001-011	Wire Holder		4
73	VYH4032-001	Roller		4
74	VYH4774-001	Stud		1
75	VJH3005-00Q	Handle Ass'y		1
76	VYH4771-001	Supporter		2
77	VKZ4001-010	Wire Holder		1
78	VYH4772-001	Holder Bracket		1
79	VYH4772-002	"		1
80	VYH4777-00A	Tuning Shaft Ass'y		1
81	VGM5120-001	Indicator	IND301, 401	1
82	VYSR102-009	Spacer	t = 20, 20 x 40 mm, Rubber	2
83	VYH2130-002	Tuning Chassis Ass'y		1
84	VYH4032-001	Roller		1
85	VYH3196-001	Dial Drum		1
86	VHR2TK9-05AT	Dial Rope		1
87	VJN4058-001	Needle		1
88	VJK2132-002	Dial Scale		1
89	-	Tuner P.W.B. Ass'y		1
90	-	LED P.W.B. Ass'y		1
91	VXP4143-002	Push Button	Band	8
92	VYH4810-001	Arm		1
93	-	Pre-Amp. P.W.B. Ass'y		1
94	QHX2075-001	Wire Clamp	Pre-Amp. P.W.B. x 8, Amp. x 3	11
95	-	Main Amp. P.W.B. Ass'y		1
96	VMZ0001-001	Earth Terminal		1
97	VYH4816-001	C.B. Holder (1)		2
98	VYH4817-001	" (2)		2
99	VYH4901-001	Support Bracket		1
100	VYH4864-001	Bracket		1
101	VJD3283-003	Jack Board		1
102	VYH3207-001	Shield		1
103	-	Mecha. Ass'y		1
104	VJD4507-001	Cassette Plate		1
105	VND4012-002	Head Plate	R/P Head	1
106	THC037417-02	"	E. Head	1
107	RCSA6000	C. Ring		1
108	VKZ4001-011	Wire Holder	Dial Scale x 5, Jack Board x 1	6
109	VKC5145-003S	Counter Reset Button		1
151	Q03091-105	Washer		2
152	WNB2600N	"	Roller x 2, Tuning Chassis Ass'y x 1	3
153	Q03093-840	"		1
154	" -837	"		1
155	REE5000	E-Ring		1
156	VKY4175-001	Spring		1
157	50153-3	"		1
158	-	-		-
159	SBSF2610Z	Screw	Speaker Ring	12
160	SBSF4010Z	"	Speaker	8
161	SBSF2608Z	"	Tweeter Frame x 4, P.W.B. - Frame x 1	5
162	SBSF3010Z	"	E.C. Mic x 2, Connector P.W.B. x 1, Cabi. - P. SW. Ass'y x 2, Eject Lever x 2, Socket Ass'y - Cabi. x 4, Door Holder x 2	13
163	SBSF3010Z	"	LED Ass'y - Chassis x 1, Shield x 2, Wire Holder x 5	10
164	SSSP3006ZS	"	Power Switch Ass'y	2
165	SSSP3006M	"	SW. - Holder	8

Ref. No.	Parts No.	Parts Name	Remarks	Q'ty
166	SBSF3008Z	Screw	Front - MMS. Ass'y x 2, Jack P.W.B. x 2, Speaker x 4	8
167	SPSP3006MS	"	Socket Ass'y	2
168	SBSF3012Z	"	Gear	2
169	SBSF2616Z	"	Frame - Cabi.	2
170	SBSF3030V	"	Mecha. - Chassis - F. Cabi.	1
171	SBSF3014C	"	Chassis - F. Cabi.	7
172	SBSF3012R	"	"	2
173	SDSP3008RS	"	"	2
174	SBSB3006Z	"	Wire Holder	1
175	DPSP3018ZS	"	Holder Bracket	4
176	SSSP2608Z	"	Arm	1
177	SBSF3010V	"	Mecha. - Chassis	4
178	SDSB2605R	"	Mecha. Ass'y	2
179	SBSF3012V	"	C.B. Holder - Chassis x 2, Jack Board x 4, Supporter Bracket x 1	7
182	SBSB3008Z	"	Socket Ass'y	1
183	SSSP3006M	"	Bracket - Switch	4

# Mechanical Component Parts

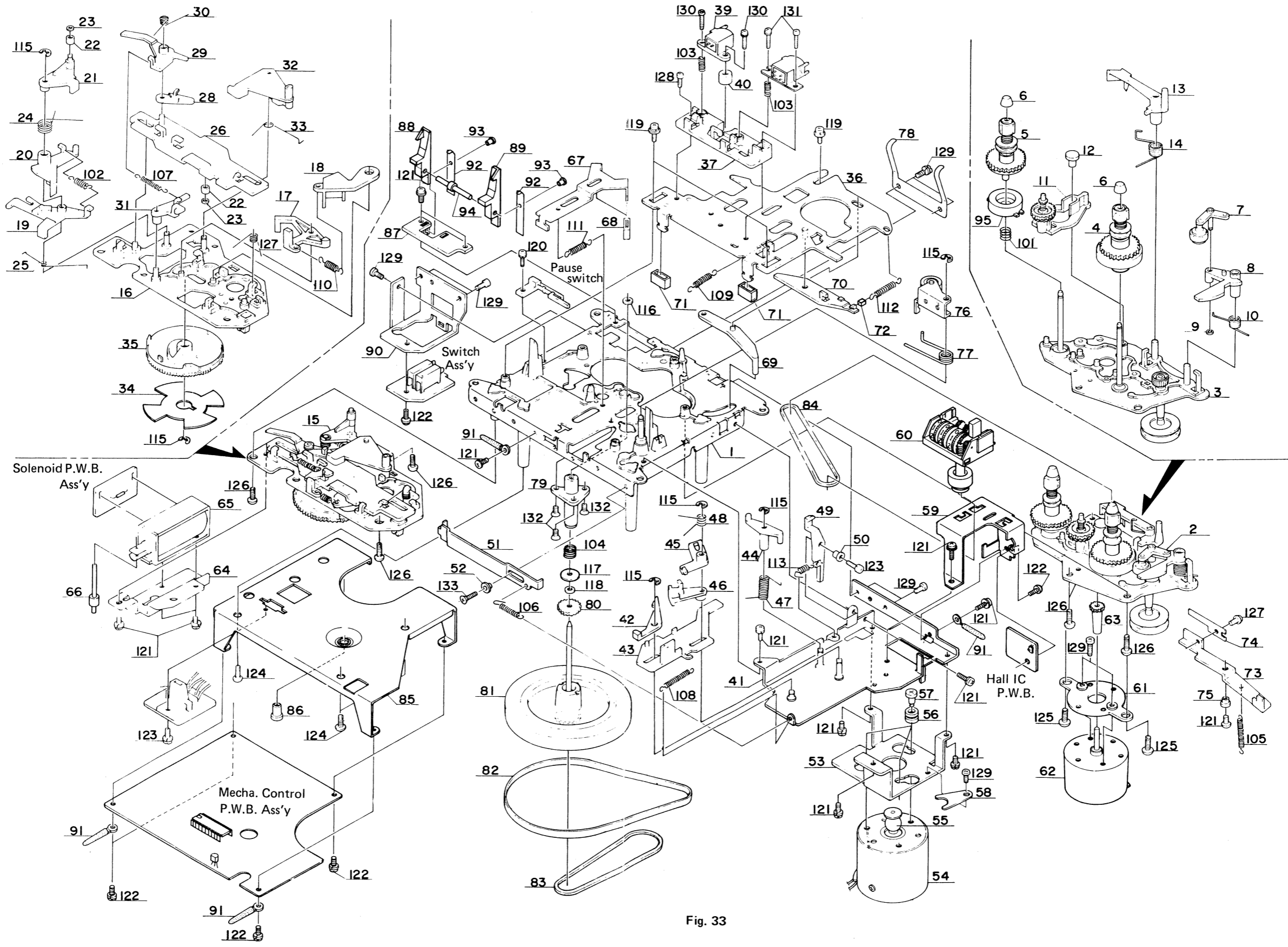

Fig. 33

## Mechanical Component Parts List

Ref. No.	Parts No.	Parts Name	Remarks	Q'ty
1	VKL1162-00F	Chassis Base Ass'y		1
2	VKL3214-00F	Reel Disk Ass'y Unit		1
3	VKL3215-00B	Reel Disk Bracket Ass'y		1
4	VKR4246-00A	Reel Disk Ass'y	Take-up	1
5	VKR4247-00A	Reel Disk Ass'y	Supply	1
6	VKR4160-001	Reel Stopper		2
7	VKS4240-00A	Idler Arm Ass'y		1
8	VKS4170-001	Take-up Lever		1
9	TEP357421-05	Special Washer	Take-up Arm	1
10	VKW4181-001	Take-up Lever Spring		1
11	VKS4203-00B	FF. Rew. Gear Ass'y		1
12	VKS4174-001	Lock Pin		1
13	VKS4175-001	Neutral Arm		1
14	VKW4182-001	Neutral Arm Spring		1
15	VKL3217-00D	Drive Gear Ass'y Unit		1
16	VKL3218-00B	Gear Holder Ass'y		1
17	VKS4176-001	Stop Arm		1
18	VKS4177-001	Kick Arm		1
19	VKS4178-001	Pause Arm (3)		1
20	VKS4179-001	" (2)		1
21	VKS4180-00A	Pause Arm (1) Ass'y		1
22	VKH3000-031	Collar		2
23	VKZ4004-001	Special Washer		2
24	VKW4183-001	Pause Arm Spring	Pause Arm (1), (2)	1
25	VKW4184-001	"	Pause (3)	1
26	VKS4182-00B	Slide Bar Ass'y		1
27	VKW4185-001	Slide Bar Spring		1
28	VKS4184-001	Play Arm (2)		1
29	VKS4185-001	" (3)		1
30	VKW4186-001	Play Arm Spring		1
31	VKS4186-001	Brake Arm		1
32	VKS4187-001	Play Arm (1)		1
33	VKW4187-001	Play Arm (1) Spring		1
34	VKZ4134-002	Control Plate		1
35	VKS3114-002	Drive Gear		1
36	VKL3220-00C	Slide Bar Ass'y		1
37	VKS2102-001	Head Mount Base		1
38	VGH0421-006	R/P Head	VND4012-002 = Head Plate	1
39	ZMM090414-0A	E. Head	THC037417-02 = Head Plate	1
40	VKH4215-001	Head Collar		1
41	VKL3264-00B	Side Bracket Ass'y		1
42	VKS4190-001	Eject Arm		1
43	VKS4334-001	Eject Slide Bar		1
44	VKS4191-001	Safety Arm (1)		1
45	VKS4234-001	Safety Arm (2)		1
46	VKS4235-001	Safety Arm (3)		1
47	VKW4188-001	Safety Arm Spring		1
48	VKW4220-001	"		1
49	VKS4342-001	Lock Arm		1
50	VKH3001-039	Flange Collar		1
51	VKL4661-002	Stop Slide Bar		1
52	VKH4306-001	Collar		1
53	VKL4879-001	Motor Bracket		1
54	MHI-5E2LDPB	Motor	Capstan	1
55	VKS4188-004	Motor Pulley		1
56	VKZ4130-001	Cushion Rubber		3
57	VKZ4109-001	Motor Screw		3
58	TFB345469-01	Rubber Stopper		1
59	VKL5014-001	Counter Bracket		1
60	VKC5145-002S	Tape Counter		1
61	VKL4657-003	Reel Motor Bracket		1
62	BFT6B01	Reel Motor		1
63	VKS4193-002	Motor Gear		1
64	VKL4658-002	Solenoid Bracket		1
65	VGP0401-005	D.C. Solenoid		1

Ref. No.	Parts No.	Parts Name	Remarks	Q'ty
66	VKH4324-001	Solenoid Pin		1
67	VKL4659-001	Brake Bar		1
68	VKZ4129-001	Brake Rubber		2
69	VKS4353-001	Take-off Lever		1
70	VKS4277-001	Slide Base Arm		1
71	T44341-001	Rubber Tire		2
72	TJN265559-04	Silencer		1
73	VKL4925-001	Kick Lever		1
74	VKY4204-002	Spring Plate		1
75	VKH3001-024	Flange Collar		1
76	VKP4106-00B	Pinch Roller Arm Ass'y		1
77	VKW4189-001	Pinch Roller Spring		1
78	VKY4171-001	Pack Spring		1
79	VKF4108-00A	Capstan Metal Ass'y		1
80	VKS4199-001	Flywheel Gear		1
81	VKF3114-00B	Flywheel Ass'y		1
82	VKB3001-012	Belt	Capstan	1
83	VKB3000-017H	"	Take-up	1
84	" -031H	"	Counter	1
85	VKL3305-001	Flywheel Holder		1
86	TEP357456-01	Thrust Bearing		1
87	VKS4271-001	Arm Holder		1
88	VKS4322-001	Rec. Safety Arm		1
89	VKS4323-001	Cassette Switch Arm		1
90	VKL4881-003	SW. Bracket		1
91	VKZ4001-007	Wire Holder		4
92	VKY4204-001	Safety Plate		2
93	VKS4324-001	Pin		2
94	VKH4291-001	Shaft		1
95	VKS4247-001	Back Tension Base		1
101	THIS DWG.	Comp. Spring	Back Tension	1
102	VKW3000-014	Tension Spring	Pause Arm (2), (3)	1
103	VKW3001-020	Comp. Spring	R/P, E. Head	2
104	VKW3001-044	"	Thrust	1
105	VKW3002-011	Tension Spring		1
106	" -020	"	Stop S. Bar	1
107	" -022	"	Play Arm (3), Brake Arm	1
108	" -038	"	Eject S. Bar	1
109	" -042	"	Slide Base	1
110	" -046	"	Kick Arm	1
111	" -054	"	Brake Bar	1
112	" -060	"	Slide B. Arm	1
113	" -066	"	Lock Arm	1
115	REE2500	E-Ring	Pause Arm (1) Ass'y x 1, Drive Gear x 1, Eject Slide Bar x 3, Pinch Roller Spring x 1	6
116	Q03093-522	Washer	Oil Cut	1
117	" -628	"	Thrust	1
118	" -827	"	"	1
119	DPSP2605Z	Screw	Slide Base	3
120	LPSP2004Z	Ass'y Screw	Pause SW.	1
121	LPSP2604Z	"	Motor Bracket, Counter Barcket x 5, Side Bracket x 2, Solenoid, Solenoid Bracket x 4, Flange Collar x 1, Wire Holder x 1	13
122	LPSP2605Z	"	Mecha. Con, Auto Stop, Rec. Safety	6
123	LPSP2606Z	"	Lock Arm x 1, Photo C. x 1	2
124	SBSB2608Z	Tapping Screw	Flywheel Holder	3
125	SPSA2608Z	"	Motor Bracket	2
126	SPSB2608Z	"	Reel Unit x 3, Gear Ass'y Unit x 3	6
127	SPSP2003Z	Screw	Spring Plate	1
128	SPSP2004N	"	H. Mount Base	1
129	SPSP2603Z	"	Rubber Stopper x 1, Side Bracket x 2, Reel Motor x 2, Pack Spring x 2, SW. Bracket x 3	10
130	SPSX2008N	"	E. Head	2
131	SPSX2010N	"	R/P Head	2
132	SSSP2605Z	"	Capstan Metal	3
133	SSSP2606Z	"	Stop Slide Bar	1

# Tuner P.W. Board Parts

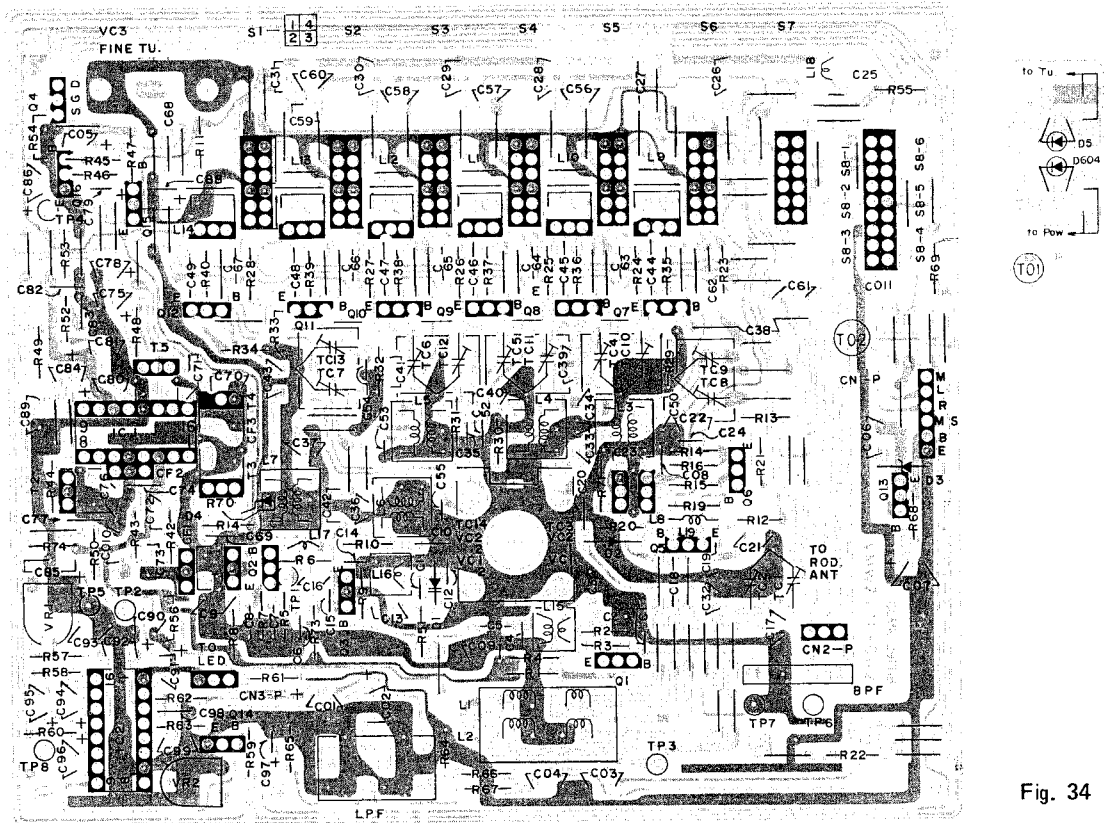

Fig. 34

## Tuner P.W. Board Parts List

Ref. No.	Parts No.	Parts Name	Remarks	Q'ty
Q1, 2	VMW2171-002	P.W. Board		1
Q3	2SC535(B)	Transistor		2
Q4	2SA838(C)	"		1
Q5-12	2SK246(GR, BL)	"		1
	2SC929(D)	"		8
Q13	2SD468(C)	"		1
Q14, 15, 16	2SC923(E,U)	"		3
IC1	HA12413	IC		1
IC2	AN7410N	"		1
D1	1S553T	Vari. Cap.		1
D2	1K34A	Ge. Diode		1
D3	HZ6C1L	Zener Diode		1
D4	MA150	Si. Diode		1
D5	1K34A	Ge. Diode		1
BPF	VBP3M4E-001	B.P. Filter		1
CF1, 2	V03059-013	C. Filter		2
LPF	VQZ0011-001	L.P. Filter		1
VR1, 2	QVP8A0B-014	V. Resistor	10 kΩ	2
T1	VQT7F12-104	I.F.T.		1
T2	VQT7F07-501	"		1
T3, 4, CF3	VQT7A31-104	"		1
T5	VQT7A11-301	"		1
L1, 2	VQB014A-304	Bar Ant. Ass y	MW, SW1	1
L3	VQR1001-311	ANT. Coil	SW2	1
L4	" -312	"	SW3	1
L5	" -202	"	SW4	1
L6	" -313	"	SW5	1
L7	" -302	"	SW6	1
L8	VQM7T03-301	OSC Coil	MW	1
L9	VQS7S02-301	"	SW1	1
L10, 11	" -302	"	SW2, SW3	2
L12	" -303	"	SW4	1
L13	" -305	"	SW5	1
L14	" -305	"	SW6	1
L15	VQF1B12-001	RF Coil	FM	1
L16	V03105-029	OSC Coil	FM	1
L17	V03047-6	Coil	FM	1
L18	V03047-21	"	SW	1
L19, 20	VQP0003-471	Inductor		2

Ref. No.	Parts No.	Parts Name	Remarks	Q'ty
R1	QRD161J-334	C. Resistor	330 k $\Omega$ 1/6 W	1
R2	" -332	"	3.3 k $\Omega$ "	1
R3	" -680	"	68 $\Omega$ "	1
R4, 8	" -271	"	270 $\Omega$ "	2
R5	QRD141J-103S	"	10 k $\Omega$ 1/4 W	1
R43, 47	QRD161J-103	"	10 k $\Omega$ 1/6 W	2
R6, 70	" -273	"	27 k $\Omega$ "	2
R7, 14, 58, 75	" -102	"	1 k $\Omega$ "	4
R9, 48	" -474	"	470 k $\Omega$ "	2
R10, 35	" -561	"	560 $\Omega$ "	2
R11	" -154	"	150 k $\Omega$ "	1
R12	" -153	"	15 k $\Omega$ "	1
R26	" -105	"	1 M $\Omega$ "	2
R13	" -564	"	560 k $\Omega$ "	1
R15,19,21,36,37,39,71,73	" -101	"	100 $\Omega$ "	8
R16	" -470	"	47 $\Omega$ "	1
R17, 41, 61	" -331	"	330 $\Omega$ "	3
R44, 49, 76	" -562	"	5.6 k $\Omega$ "	3
R78	" -820	"	82 $\Omega$ "	1
R20	" -392	"	3.9 k $\Omega$ "	1
R22	" -182	"	1.8 k $\Omega$ "	1
R23-25, 27, 28	" -684	"	680 k $\Omega$ "	5
R29-34, 66-68	" -152	"	1.5 k $\Omega$ "	9
R38	" -471	"	470 $\Omega$ "	1
R45	" -472	"	4.7 k $\Omega$ "	1
R46	" -563	"	56 k $\Omega$ "	1
R50, 51	" -104	"	100 k $\Omega$ "	2
R52	QRD141J-222S	"	2.2 k $\Omega$ 1/4 W	1
R55	QRD161J-222	"	2.2 k $\Omega$ 1/6 W	1
R53, 62, 69	" -273	"	2.7 k $\Omega$ "	3
R54	" -473	"	47 k $\Omega$ "	1
R56	" -100	"	10 $\Omega$ "	1
R57	" -183	"	18 k $\Omega$ "	1
R59	" -223	"	22 k $\Omega$ "	1
R60, 79	" -682	"	6.8 k $\Omega$ "	2
R63	QRD141J-272	"	2.7 k $\Omega$ 1/4 W	1
R64, 65	QRD161J-103	"	10 k $\Omega$ 1/6 W	2
R42	" -221	"	220 $\Omega$ "	1
R72	" -823	"	82 k $\Omega$ "	1
R74	" -330	"	33 $\Omega$ "	1
TC1, 2, 4-13	QAT2002-001	T. Capacitor		6
VC1-1, 2, 2-1, 2 TC3, 14, 15, 16	QAP1224-521	V. Capacitor		1
C1, 15, 37	QCS11HJ-180	C. Capacitor	18 pF 50 V	3
C2, 3, 8, 9, 09	QCF11HP-103	"	0.01 $\mu$ F "	5
C4	QCS11HJ-240	"	24 pF "	2
C5	" -6R0	"	6 pF "	1
C6, 016	" -100	"	10 pF "	2
C7	" -471	"	470 pF "	1
C10	QCC11EM-103	"	0.01 $\mu$ F "	1
C11	QCT05CH-7R0	"	7 pF "	1
C12	" -240	"	24 pF "	1
C13, 14, 25	" -8R0	"	8 pF "	3
C16, 26, 026	QCS11HJ-5R0	"	5 pF "	3
C019	" -8R0	"	8 pF "	1
C017, 020, 025, 024	" -3R0	"	3 pF "	4
C18, 38-43, 41	QCY41HK-222	"	0.0022 $\mu$ F "	8
C19, 20, 69, 73, 74, 76, 82, 92, 08, 83	QCC11EM-473	"	0.047 $\mu$ F "	10
C21	QCS11HJ-271	"	270 pF "	1
C22, 72, 77, 06, 018	QCC11EM-223	"	0.022 $\mu$ F "	5
C23	QCY41HK-472	"	0.0047 $\mu$ F "	1
C24	QCT05ZL-5R0	"	5 pF "	1
C33, 51	" -120	"	12 pF "	2
C024	" -100	"	10 pF "	1
C17, 021	" -2R0	"	2 pF "	2

Ref. No.	Parts No.	Parts Name	Remarks	Q'ty
C27-31	QCS11HJ-390	C. Capacitor	39 pF 50 V	4
C32	" -330	"	33 pF "	1
C34	" -300	"	30 pF "	1
C35	" -180	"	18 pF "	1
C44-47	QCY41HK-182	"	0.0018 $\mu$ F "	4
C49	QCT41HK-272	"	0.0027 $\mu$ F "	1
C50	QCT05WK-150	"	15 pF "	1
C55	" -150	"	15 pF "	1
C53	QCS11HJ-200	"	20 pF "	1
C52	" -240	"	240 pF "	1
C54	" -510	"	51 pF "	1
C56	QCY41HK-471	"	470 pF "	1
C57, 64	QCT05CH-240	"	24 pF "	2
C58	QCY41HK-821	"	820 pF "	1
C59	" -681	"	680 pF "	1
C60	" -151	"	150 pF "	1
C61	QCS11HJ-361	"	360 pF "	1
C62	QFS41HJ-122	P. Capacitor	0.0012 $\mu$ F "	1
C63	" -331	"	330 pF "	1
C65	" -561	"	560 pF "	1
C66	" -681	"	680 pF "	1
C67	" -151	"	150 pF "	1
C68	QCS11HJ-470	C. Capacitor	47 pF "	1
C70, 48	QCY41HK-152	"	0.0015 $\mu$ F "	2
C75	QET41AR-476	E.Capacitor	47 $\mu$ F 10 V	1
C78, 88, 05, 91	QET41ER-475	"	4.7 $\mu$ F 25 V	4
C79	QET41AR-336	"	33 $\mu$ F 10 V	1
C81	" -477	"	470 $\mu$ F "	1
C84	QET41HR-105	"	1 $\mu$ F "	1
C85, 86	" -104N	"	0.1 $\mu$ F "	2
C97	QET41CR-226	"	22 $\mu$ F 16 V	1
C89	QCS11HJ-121	C.Capacitor	120 pF "	1
C90	QET41AR-107	E.Capacitor	100 $\mu$ F "	1
C93	QFS41HJ-471	"	470 pF "	1
C94	QEB41HM-224	"	0.22 $\mu$ F "	1
C95	" -474M	"	0.47 $\mu$ F "	1
C96, 01, 02	QET41HR-474	"	0.47 $\mu$ F "	3
C98, 99	QFM41HK-153	M. Capacitor	0.015 $\mu$ F 50 V (RC-M90JW)	2
C98, 99	" -103	"	0.01 $\mu$ F 50 V (RC-M90W)	2
C03, 04	QCY41HK-472	C. Capacitor	0.0047 $\mu$ F 50 V	2
C012	QCS11HJ-151	"	150 pF "	1
C013	QCC11EM-333	"	0.033 $\mu$ F 25 V	1
C014	QCS11HJ-151	"	150 pF 50 V	1
C015	QCC11EM-473	"	0.047 $\mu$ F 25 V	1
C07	QET41AR-477	E. Capacitor	470 $\mu$ F 10 V	1
C011	QCY41HK-272	C. Capacitor	0.0027 $\mu$ F 50 V	1
C010	QCS11HJ-151	"	150 pF "	1
C023	" -4R0	"	4 pF "	1
VC3	QAT5001-201	M.V. Capacitor	200 pF	1
	VYH4776-001	Bracket		1
	LPSP3008ZS	Ass'y Screw		2
S1-1...4, 2-1...4, 3-1...4, 4-1...4, 5-1...4, 6-1...4, 7-1...4, 8-1...6	QST3841-V01	Push Switch		1
CN1-P	VKL3143-001	Board in Tab		4
CN2-P	QMV5005-006	Connector	to Pre Amp.	1
CN3-P	" -003	"	to ANT.	1
	" -003	"	LED	1
	VYH4906-001	Shield		1
(LED)				
D5, 603	VMW3156-001	P.W. Board		1
	SLP141B	LED		2

# Pre-Amp P.W. Board Parts

→ Front

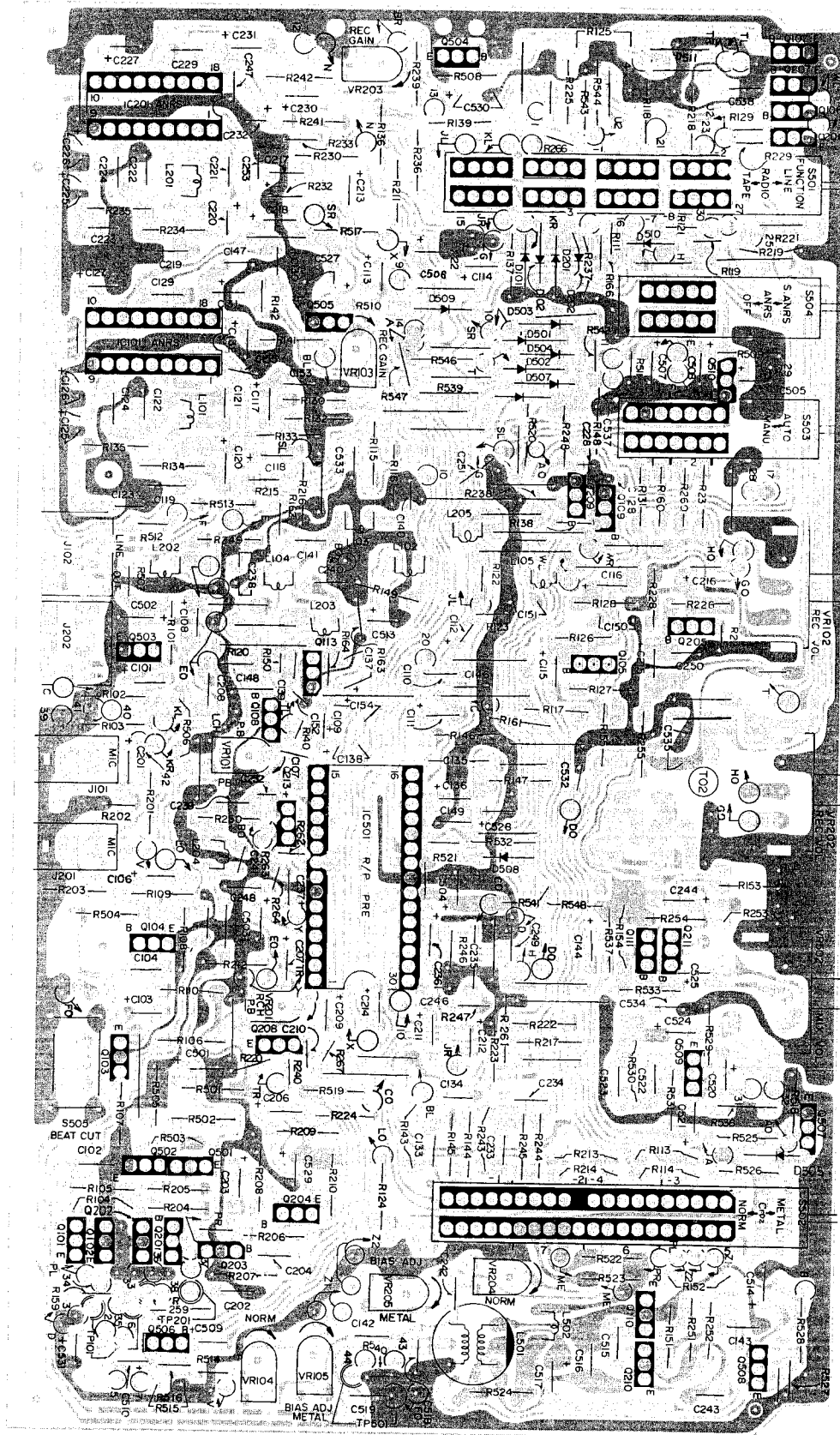

Fig. 35



## Pre Amp. P.W. Board Parts List

Ref. No.	△	Parts No.	Parts Name	Remarks	Q'ty
S501-1...6		VMW1037-001	P.W. Board		1
S502-1...7		QSL8310-103V	Lever Switch	FUNCTION	1
S503-1...3		" -101	"	TAPE	1
S504		QSL4210-103	"	AUTO/MANU	1
		QSL2310-102	"	ANRS	1
S505		QSS1201-021	Slide Switch	BEAT CUT	1
VR101, 201		QVP8A0B-054	V. Resistor	PB LEVEL	1
VR102, 202		QVF0A2A-054M	"	REC VOL.	2
VR103, 203		QVP8A0B-014	"	REC LEVEL	2
VR104, 204		" -025	"	BIAS (NORM)	2
VR105, 205		" -015	"	" (METAL)	2
VR502		QVF0E2A-024M	"	MIC MIX	1
J101, 201		VDE6028-A01	Volume Kit		1
J102		QMS3501-016	Jack	MIC	2
		VMC0002-002	Pin Jack	LINE OUT	1
J202		" -001	"	"	1
L501		VQH1009-020	OSC Coil	BIAS	1
L502		VQP0001-102S	Inductor		1
L101, 201		" -183S	"		2
L102		" -562S	"		1
L202		VQP9001-003	"		1
L103, 203, 104, 204		" -001	"		4
L105, 205		" -001	"		2
IC501		M51123P	IC		1
IC101, 201		AN7363	"		2
Q101, 201, 102, 202		2SC1845(E,U)	Transistor		4
Q103, 203, 109, 209, 110, 210, 508		2SC2001(L,K)	"		7
Q104, 204		2SC1845(F)	"	or 2SC1843(F)	2
Q105, 205, 111, 211		2SC945L(Q,P)	"		4
Q106, 206, 107, 207, 108, 208, 113, 213, 502, 503, 505, 506, 507, 510		2SC945(Q,P)			14
Q501, 504		2SA992(E,F)	"		2
Q509		2SC945L(P)	"		1
D101, 201, 102, 202, 501-511		1S2076	Si. Diode		15
R101, 201, 112, 212, 502, 503, 510, 532		QRD141J-332S	C. Resistor	3.3 kΩ 1/4 W	8
R102, 202, 113, 213, 114, 214, 136, 236		" -272S	"	2.7 kΩ "	8
R103, 203, 115, 127, 141, 241, 211		" -152S	"	1.5 kΩ "	7
R104, 204, 250, 531, 150		" -822S	"	8.2 kΩ "	5
R105, 205, 144, 244		" -392S	"	3.9 kΩ "	4
R106, 206, 125, 225, 128, 228, 134, 234, 140, 240, 506		" -472S	"	4.7 kΩ "	11
R107, 207, 223, 164, 264, 504		" -223S	"	22 kΩ "	6
R108, 208		" -471S	"	470 Ω "	3
R109, 209, 533		" -225S	"	2.2 MΩ "	3
R110, 210, 130, 230, 221, 146, 117, 217, 160, 260, 505, 123, 223		" -153S	"	15 kΩ "	13
R111		QRD161J-152	"	1.5 kΩ 1/6 W	1
R116, 216, 137, 237, 143, 243, 518, 219		QRD141J-333S	"	33 kΩ 1/4 W	8
R118, 218, 222, 154, 254		" -123S	"	12 kΩ "	5
R119		QRD161J-103	"	10 kΩ 1/6 W	1
R120, 220		QRD141J-560S	"	56 Ω 1/4 W	2
R121		QRD161J-153	"	15 kΩ 1/6 W	1
R122		QRD143J-123S	"	12 kΩ 1/4 W	1
R164, 264, 527		" -223S	"	22 kΩ "	3
R124, 224		" -224S	"	220 kΩ "	2

Ref. No.	△	Parts No.	Parts Name	Remarks	Q'ty
R126, 226		QRD141J-684S	C. Resistor	680 kΩ 1/4 W	2
R129, 229, 167, 267		" -472	"	4.7 kΩ "	4
R131, 231, 155, 255, 133		" -393S	"	39 kΩ "	5
R132		" -473S	"	47 kΩ "	1
R135, 235		" -680S	"	68 Ω "	2
R138, 238, 511, 543		QRD143J-472S	"	4.7 kΩ "	4
R139, 239		QRD141J-222S	"	2.2 kΩ "	2
R142		QRD143J-392S	"	3.9 kΩ "	1
R145, 245, 151, 251		QRD141J-183S	"	18 kΩ "	4
R147, 242		" -273S	"	27 kΩ "	2
R148, 248, 520		" -562S	"	5.6 kΩ "	3
R149, 249		" -121S	"	120 Ω "	2
R152, 252		QRD141J-3R3S	"	3.3 Ω "	2
R153, 253		" -821S	"	820 Ω "	2
R536		" -561S	"	560 Ω "	1
R537		" -331S	"	330 Ω "	1
R159, 259		" -100S	"	10 Ω "	2
R161, 261, 508		" -104S	"	100 kΩ "	3
R162, 262, 232		QRD143J-473S	"	47 kΩ "	3
R163, 263, 248, 166, 266, 542		" -562S	"	5.6 kΩ "	6
R215, 227, 507		" -152S	"	1.5 kΩ "	3
R233		" -393S	"	39 kΩ "	1
R246		" -153S	"	15 kΩ "	1
R247		" -273S	"	27 kΩ "	1
R501, 528		" -101S	"	100 Ω "	2
R509, 530		QRD141J-105S	"	1 MΩ "	2
R512		QRD143J-103S	"	10 kΩ "	1
R513		QRD141J-103S	"	10 kΩ "	1
R514		QRD143J-272S	"	2.7 kΩ "	1
R515		" -221S	"	220 Ω "	1
R516		" -684S	"	680 kΩ "	1
R517		QRH141J-4R7	"	4.7 Ω "	1
R519		QRD141J-471S	"	470 Ω "	1
R521, 541		QRD143J-181S	"	180 Ω "	2
R522	△	QRD149J-180S	Fusible Resistor	18 Ω "	1
R523	△	" -470S	"	47 Ω "	1
R524	△	" -100S	"	10 Ω "	1
R525		QRD141J-181S	C. Resistor	180 Ω "	1
R526		" -122S	"	1.2 kΩ "	1
R529		" -271S	"	270 Ω "	1
R540		QRD143J-1R0S	"	1 Ω "	1
R544		QRD141J-682S	"	6.8 kΩ "	1
R546		QRH141J-2R2	"	2.2 Ω "	1
R547		QRD143J-222S	C. Resistor	2.2 kΩ "	1
R548		" -151S	"	150 Ω "	1
C101, 201, 111, 211, 520, 525		VMZ0015-001 QET61HR-474ZM	Post Pin E. Capacitor	0.47 μF 50 V	6 6
C102, 202		QCS11HJ-451	C. Capacitor	450 pF "	2
C103, 203		QEB41HM-105	E. Capacitor (Low Peak)	1 μF "	2
C104, 204, 522		QCS31HJ-101Z	C. Capacitor	100 pF "	3
C106, 206, 207, 217, 130, 230, 131, 231, 136, 236, 107, 117		QET41HR-335	E. Capacitor	3.3 F "	12
C108, 208, 212, 113, 213, 114, 214, 115, 215, 116, 216, 118, 218, 120, 144, 509		QET41HR-105	"	1 μF "	16
C109, 128, 228, 502		QET41AR-336	"	33 μF 10 V	4
C110, 210		QFM31HJ-273Z	M. Capacitor	0.027 μF 50 V	2
C119, 219, 515		" -103Z	"	0.01 μF "	3
C121, 221		QCS11HJ-301	C. Capacitor	300 pF "	2
C122, 222, 129, 229		QFM31HJ-152Z	M. Capacitor	0.0015 μF "	4
C123, 223		QFM41HJ-683	"	0.068 μF "	2
C124		QFM31HJ-272Z	"	0.0027 μF "	1

Ref. No.	△	Parts No.	Parts Name	Remarks	Q'ty
C125, 225		QEB41HM-104	E. Capacitor (Low Leak)	0.1 $\mu$ F 50 V	2
C126, 226		" -475M	" "	4.7 $\mu$ F "	2
C127, 227		QET41AR-107	E. Capacitor	100 $\mu$ F 10 V	2
C132, 232, 513, 528, 532, 535		" -227	"	220 $\mu$ F "	6
C133, 233		QCS11HJ-681	C. Capacitor	680 pF 50 V	2
C134, 234		QFM31HJ-122Z	M. Capacitor	0.0012 $\mu$ F "	2
C135, 235		QFM41HJ-184	"	0.18 $\mu$ F "	2
C137, 237, 152, 252		QET41ER-475	E. Capacitor	4.7 $\mu$ F 25 V	4
C138, 238		QFM41HJ-153	M. Capacitor	0.015 $\mu$ F 50 V	1
C139, 239		" -102	"	0.001 $\mu$ F "	2
C140, 240, 146, 246		QCS11HJ-471	C. Capacitor	470 pF "	4
C141, 241		" -561	"	560 pF "	2
C142, 242		QFS32BJ-331	P.S. Capacitor	330 pF 125 V	2
C143, 243		QFM31HJ-332Z	M. Capacitor	0.0033 $\mu$ F 50 V	2
C147, 247, 150, 250, 153, 253		QCS11HJ-221	C. Capacitor	220 pF "	6
C148, 248		QCC11EH-103	"	0.01 $\mu$ F 25 V	2
C149, 249		QCS11HJ-331	"	330 pF 50 V	2
C151, 251		" -501	"	500 pF "	2
C154, 254, 530		QET41CR-106	E. Capacitor	10 $\mu$ F 16 V	3
C156		QCS11HJ-301	C. Capacitor	300 pF 50 V	1
C157, 257		QFN41HJ-224	M. Capacitor	0.22 $\mu$ F "	2
C209		QET61AR-336ZM	E. Capacitor	33 $\mu$ F 10 V	1
C238		QFM41HJ-153	M. Capacitor	0.015 $\mu$ F 50 V	1
C501, 507		QET61AR-476ZM	E. Capacitor	47 $\mu$ F 10 V	2
C503, 529		QET41AR-337	"	330 $\mu$ F "	2
C504, 514, 527		" -477	"	470 $\mu$ F "	3
C505, 508		QET61AR-476ZM	"	47 $\mu$ F "	2
C506		QET41AR-108	"	1000 $\mu$ F "	1
C510		QFM41HJ-103	M. Capacitor	0.01 $\mu$ F 50 V	1
C516		QFP82AJ-683	P.P. Capacitor	0.068 $\mu$ F 100 V	1
C517		QET61CR-106ZM	E. Capacitor	10 $\mu$ F 16 V	1
C518		QFP82AJ-123	P.P. Capacitor	0.012 $\mu$ F 100 V	1
C519		QCY41HK-222	C. Capacitor	0.0022 $\mu$ F 50 V	1
C521, 531		QET41AR-107	E. Capacitor	100 $\mu$ F 10 V	2
C523		QCS11HJ-680	C. Capacitor	68 pF 50 V	1
C524		QET41HR-474	E. Capacitor	0.47 $\mu$ F "	1
C533		QCC11EM-473	C. Capacitor	0.047 $\mu$ F 25 V	1
C534		QCY41HK-182	"	0.0018 $\mu$ F 50 V	1
C537		QET41AR-476	E. Capacitor	47 $\mu$ F 16 V	1
C538		QET41AR-227	"	220 $\mu$ F "	1
		VYH3208-002	Shield Plate		1

# Main Amp P.W. Board Parts

→ Front

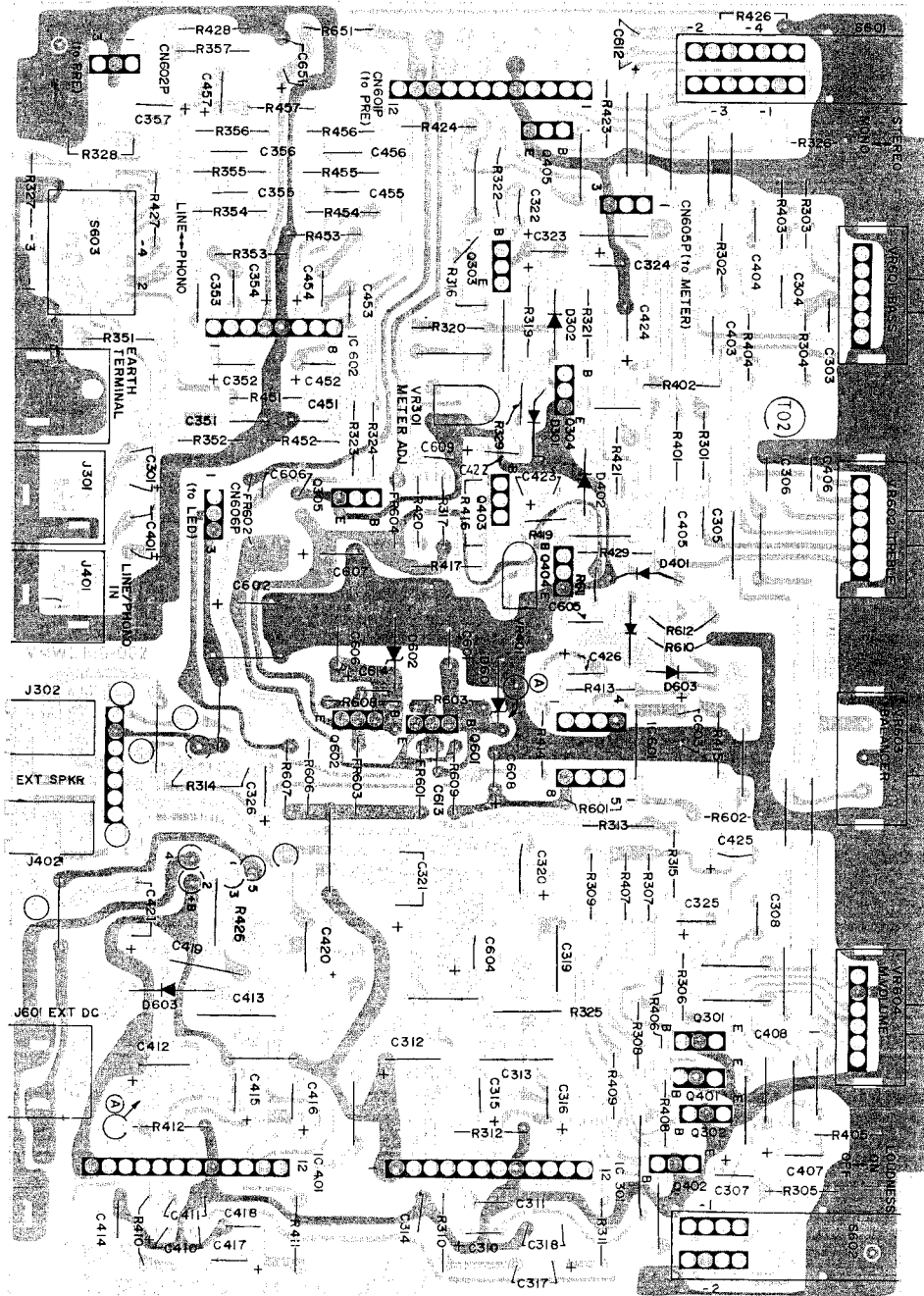

Fig. 36

## Main Amp. P.W. Board Parts List

Ref. No.	△	Parts No.	Parts Name	Remarks	Q'ty
S601-1...4		VMW2168-002	P.W. Board		1
S602-1...2		QSL4210-103	Lever Switch	MONO-STEREO	1
S603-1...4		QSL2210-101	"	LOUDNESS	1
VR301, 401		QSS4201-072	Slide Switch	LINE-PHONO	1
		QVP8A0B-013	V. Resistor	1 kΩ METER ADJ.	2
VR601-1...2, 602-1...2		QVD4A2A-015M	"	100 kΩ BASS, TREBLE	2
VR603		QVF0A2G-054M	"	50 kΩ BALANCE	1
VR604-1...2		QVN3A2B-A54M	"	50 kΩ MAIN VOL.	1
J301		VMC0002-002	Pin Jack	LINE IN	1
J302, 402		QMS3501-016	Jack	EXT. SPKR OUT	2
J401		VMC0002-001	Pin Jack	LINE IN	1
J601		QMA1221-006	DC Jack	EXT. DC IN	1
IC301, 401		AN7156N	IC		1
IC601		μPC4557(C)	"		1
IC602		BA328	"		1
Q301, 401, 302, 402		2SC536(H)	Transistor	or 2SC2001(L,K)	4
Q303, 403, 304, 404		2SC536(F,G)	"		4
Q305, 405		2SC945(Q,P)	"		2
Q601		2SD439(E)	"		1
Q602		2SD325(E)HP	"		1
D301, 401, 604, 605		1S2076	Si. Diode		4
D302, 402		1K34A	Ge. Diode		2
D601		HZ11A2	Zener Diode		1
D602		HZ9C2	"		1
D603		DSA26B	Si. Diode		1
R301, 401, 307, 407, 309, 409, 612		QRD141J-472S	C. Resistor	4.7 kΩ 1/4 W	7
R302, 402		" -822S	"	8.2 kΩ "	2
R303, 403, 607, 305, 405		" -222S	"	2.2 kΩ "	5
R304, 404, 601, 602		" -562S	"	5.6 kΩ "	4
R306, 406, 329, 429		" -152S	"	1.5 kΩ "	4
R308, 408, 604, 354, 454		" -102S	"	1 kΩ "	5
R310, 410, 311, 411		" -560S	"	56 Ω "	4
R312, 412, 352, 452		" -473S	"	47 kΩ "	4
R313, 413		" -105S	"	1 MΩ "	2
R314, 414		" -330S	"	33 Ω "	2
R315, 415		" -183S	"	18 kΩ "	2
R316, 416		" -684S	"	680 kΩ "	2
R317, 417, 322, 422, 326 426, 605		" -332S	"	3.3 kΩ "	7
R319		" -331S	"	330 Ω "	1
R320, 420, 324, 424		" -682S	"	6.8 kΩ "	4
R321, 421		" -391S	"	390 Ω "	2
R323, 423		" -122S	"	1.2 kΩ "	2
R325		QRD121J-2R2	"	2.2 Ω 1/2 W	1
R327, 427		QRD141J-104S	"	100 kΩ 1/4 W	2
R328		" -563S	"	56 kΩ "	1
R351, 451		QRD143J-182S	"	1.8 kΩ "	2
R353, 453		QRD141J-471S	"	470 Ω "	2
R355, 455		" -103S	"	10 kΩ "	2
R356, 456		" -124S	"	120 kΩ "	2
R357, 457, 606		" -683S	"	68 kΩ "	3
R419		QRD143J-331S	"	330 Ω "	1
R425		QRD123J-2R2	"	2.2 Ω 1/2 W	1
R428		QRD141J-393S	"	39 kΩ 1/4 W	1
R609		" -101S	"	100 Ω "	1
R610		" -153S	"	15 kΩ "	1
R611		QRD143J-222S	"	2.2 kΩ "	1
FR601, 603	△	QRH141J-1R0	Fusible Resistor	1 Ω "	2
FR602	△	" -2R2	"	2.2 Ω "	1

Ref. No.	△	Parts No.	Parts Name	Remarks	Q'ty
FR604	△	QRH141J-4R7	Fusible Resistor	4.7 Ω 1/4 W	1
C301, 401, 605		QET61HR-335ZM	E. Capacitor	3.3 μF 50 V	3
C302, 402		QET41HR-335	"	3.3 μF "	2
C303		QFM31HK-473Z	M. Capacitor	0.047 μF "	1
C403		QFM41HK-473	"	0.047 μF "	1
C304, 404		QFM31HK-104Z	"	0.1 μF "	2
C305, 405		QCY41HK-222	C. Capacitor	0.0022 μF "	2
C306, 406		QFM31HK-223Z	M. Capacitor	0.022 μF "	2
C307, 407		QEB41EM-224	E. Capacitor	0.22 μF 25 V	2
C308, 408		QCY41HK-182	C. Capacitor	0.0018 μF 50 V	2
C309, 409		QET41HR-474	E. Capacitor	0.47 μF "	2
C310, 410		QET41ER-475	"	4.7 μF 25 V	2
C311, 411, 353, 453		QCY41HK-102	C. Capacitor	0.001 μF 50 V	4
C312, 412		QET41ER-228	E. Capacitor	2200 μF 25 V	2
C313, 413		QFM41HJ-224	M. Capacitor	0.22 μF 50 V	2
C314, 414, 318, 418		QCC11EM-473	C. Capacitor	0.047 μF 25 V	4
C315, 316, 354, 454		QET61AR-476ZM	E. Capacitor	47 μF 10 V	4
C415, 416		QET41AR-476	"	47 μF "	2
C317, 417, 608, 651		QET61AR-107ZM	"	100 μF "	4
C391, 419		QFM41HJ-224	M. Capacitor	0.22 μF 50 V	2
C320, 420, 321, 421		QET41CR-228	E. Capacitor	2200 μF 16 V	4
C322, 422, 323, 423, 457		QET61HR-105ZM	"	1 μF 50 V	5
C351, 451		QCS11HJ-471	C. Capacitor	470 pF "	2
C355, 455		QFM31HJ-822Z	M. Capacitor	0.082 μF "	2
C356, 456		" -273Z	"	0.027 μF "	2
C357		QET41HR-105	E. Capacitor	1 μF "	1
C326		QET41CR-226	"	22 μF "	1
C426		QET61CR-226ZM	"	22 μF "	1
C601, 606		QET41AR-477	"	470 μF 10 V	2
C602, 607		" -108	"	1000 μF "	2
C603		" -107	"	100 μF "	1
C604, 616		QET41ER-227	"	220 μF 25 V	1
C609, 352, 452		QET61HR-474ZM	"	0.47 μF 50 V	3
C610		QET41ER-476	"	47 μF 25 V	1
C611		" -106	"	10 μF "	1
C612		QET41CR-106	"	10 μF 16 V	1
C613, 614		QCC11EM-103	C. Capacitor	0.01 μF 25 V	2
C615		" -104	"	0.1 μF "	1
C617		QCY41HK-152	"	0.0015 μF 50 V	1
CN601P		QMV5004-012	Connector	to PRE	1
CN602P		" -003	"	to LINE IN	1
CN605P		QMV5005-003	"	to METER	1
CN606P		" -002	"		1
		VYH3197-001	Radiation		2
		SBSB3008Z	Screw		2
		SBSB3010Z	"	IC + Radiation	2
		VMZ0001-001	Earth Terminal		1
		VYH4905-001	Heat Sink		1
		VYSP1R5-024	Spacer		1

# Other P.W. Board Parts

Mecha. Operation buttons

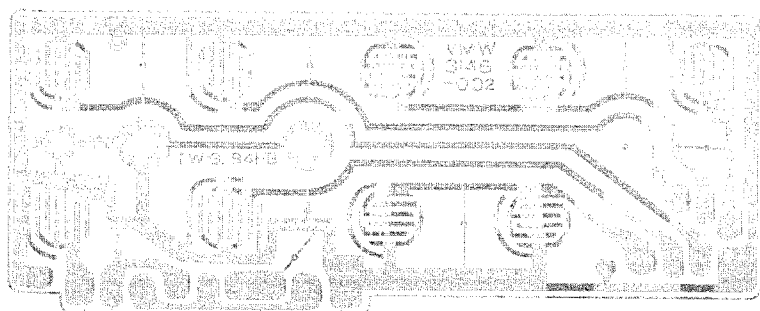

Power Switch (RC-M90W)

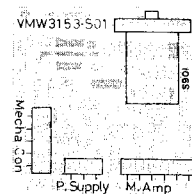

Power Switch (RC-M90JW)

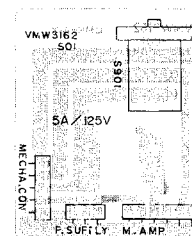

MIX Mic jacks

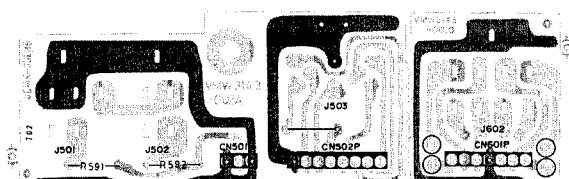

Power Supply (RC-M90W)

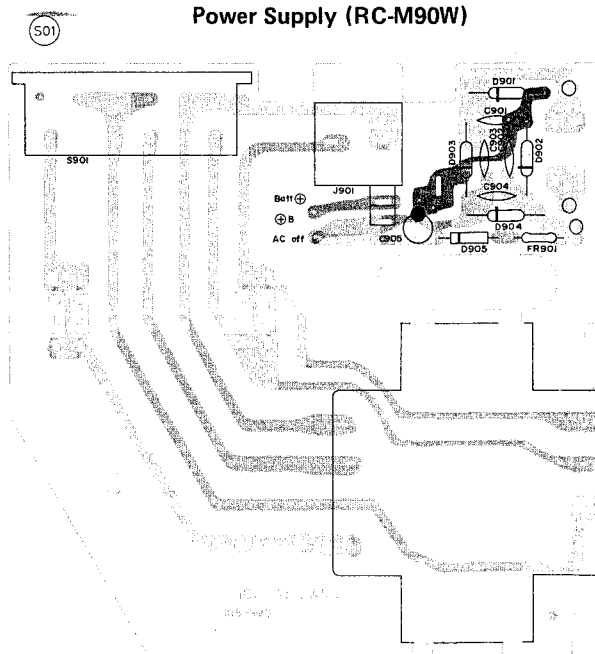

MMS

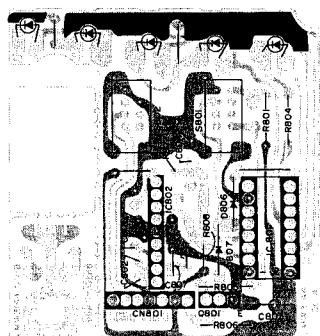

L.E.D

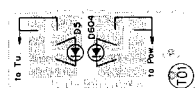

Mic wire connector



Power Supply (RC-M90JW)

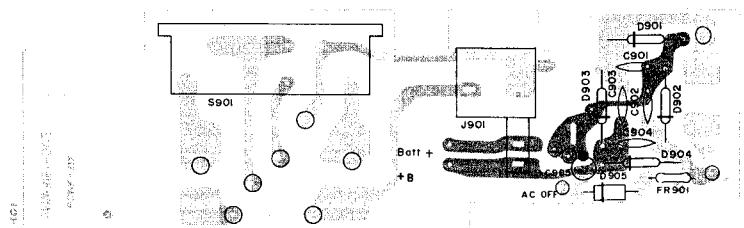

Fig. 37

## Other P.W. Board Parts List

Ref. No.	△	Parts No.	Parts Name	Remarks	Q'ty
(M.M.S.)		VMW3144-001	P.W. Board		1
S801-1...2		QSL2309-004	Lever Switch		1
S802		" -003	"		1
IC801		TC9138AP	I.C.		1
IC802		BA335	"		1
Q801		2SC945(Q,P)	Transistor		1
D801-805		LN21RP, HL	LED		5
D806, 807		1S2076	Si. Diode		2
R801		QRD141J-102S	C. Resistor	1 k $\Omega$ 1/4 W	1
R802		" -563S	"	56 k $\Omega$ "	1
R803		" -105S	"	1 M $\Omega$ "	1
R804		" -151S	"	150 $\Omega$ "	1
R805		" -332S	"	3.3 k $\Omega$ "	1
R806		" -222S	"	2.2 k $\Omega$ "	1
R807		QRD143J-474S	"	470 k $\Omega$ "	1
R808		" -473S	"	47 k $\Omega$ "	1
C802		QCY41HK-102	C. Capacitor	0.001 $\mu$ F 50 V	1
C803		QET41CR-107	E. Capacitor	100 $\mu$ F 16 V	1
C804		QCY41HK-103	C. Capacitor	0.01 $\mu$ F 50 V	1
C805		QCF11EZ-103	"	0.01 $\mu$ F "	1
C806		QFM41HK-223	M. Capacitor	0.022 $\mu$ F "	1
C807		" -823	"	0.082 $\mu$ F "	1
C808		QET41CR-226	E. Capacitor	22 $\mu$ F 16 V	1
C809		QFM41HJ-103	M. Capacitor	0.01 $\mu$ F 50 V	1
C810		QCF11HP-223	C. Capacitor	0.022 $\mu$ F "	1
CN801P		QMV5004-006	Connector	to MECHA.CON	1
(Power Switch)		VMW3153-002	P.W. Board	RC-M90W	1
S901-1...2	△	VMW3162-001	P.W. Board	RC-M90JW	1
CN901P		QSP0210-016	Push Switch		1
CN902P		QMV5004-003	Connector		1
CN903P		" -005	"		1
	△	A44594-001	Fuse Clip	RC-M90JW	2
	△	QMF51U1-5R0	Fuse	RC-M90JW	1
(MIX MIC Jacks)		VMW3143-002A	P.W. Board		1
J501		QMS6305-001	Jack	MIX MIC	1
J502		QMS6303-013	"		1
J503		QMC0888-010	DIN Socket		1
CN501P		QMV5004-003	Connector		1
CN502P		" -008	"		1
R591, 592		QRD141J-102S	C. Resistor	1 k $\Omega$ 1/4 W	2
(PHONES Jack)		VMW3143-002B	P.W. Board		1
J602		QMS6312-012	Jack	PHONES	1
CN601P		QMV5004-007	Connector		1
(Mecha. Operation buttons)		VMW3146-002	P.W. Board		1
D752		SLP144B	LED	Rec.	1
D753		SLP244B	"	Pause	1
(Power Supply)		VMW3154-001	P.W. Board	RC-M90W	1
D901-904	△	VMW3161-002	P.W. Board	RC-M90JW	1
D905		U08B-F	Si. Diode		4
FR901	△	10E1	"		1
		QRH141J-2R2	Fusible Resistor	2.2 $\Omega$ 1/4 W	1
R901		QRC121K-225	Comp. Resistor	2.2 M $\Omega$ 1/2 W	1
C901-904		QCF11EZ-223	C. Capacitor	0.022 $\mu$ F 25 V	4
C905		QET41ER-336	E. Capacitor	33 $\mu$ F "	1
S901, J901	△	QMC0262-003	AC Socket		1
S902-1...2	△	QSS2325-101	Slide Switch	RC-M90W	1
	△	" -102	"	RC-M90JW	1
T901	△	VTP66N2-15E	P. Transformer	RC-M90W	1
	△	VTP66C2-15B	"	RC-M90JW	1
	△	A44594-001	Fuse Clip	RC-M90W	2
	△	QMF51A2-R80	Fuse	RC-M90W	1
	△	VND4003-026	Fuse Label	RC-M90W	1
(LED)		VMW3156-001	P.W. Board	LED	1
(Mic Wire Connector)		VMW3110	P.W. Board	Mic Wire Connector	1



# Packing

## Position of controls and switch knobs at renewed packing

Fine tuning knob	: Center
Band selector	: MW
Tuning	: 600 kHz
Power switch	: OFF
METER/MODE switch	: MONO
BASS control	: Center
TREBLE control	: Center
BALANCE control	: Center
VOLUME control	: Center
LOUDNESS switch	: OFF
FUNCTION switch	: TAPE
NR SYSTEM switch	: OFF
REC switch	: MANU
REC level controls	: Center
MIXING MIC LEVEL control	: Center
TIMER STANDBY switch	: PLAY
MULTI MUSIC SCANNER switch	: ON
BEAT CUT switch	: "1" Normal
PHONO/LINE IN selector switch	: LINE IN

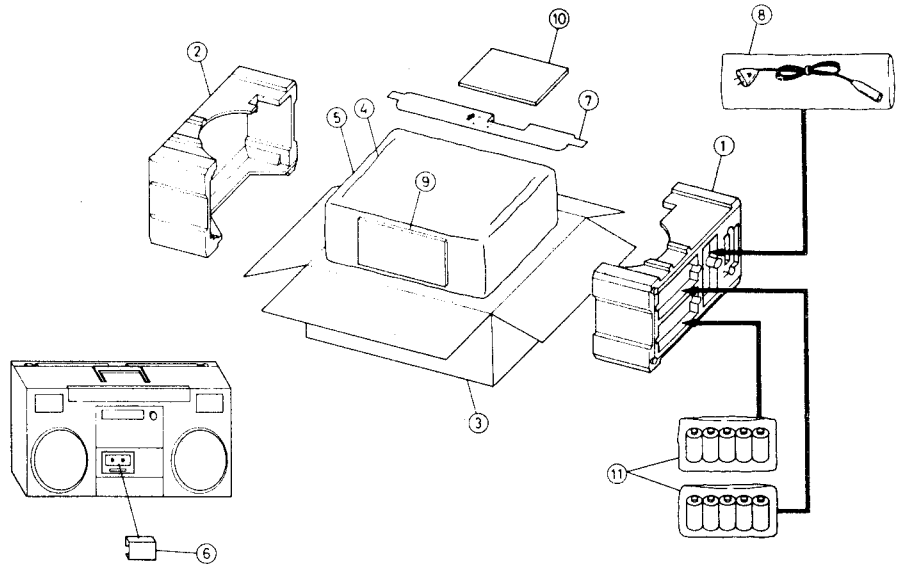

## Packing Material Parts List

Ref. No.	Parts No.	Parts Name	Remarks	Q'ty
1-3	VDP5072-002A	Carton Ass'y	RC-M90JW	1
	" -003A	"	RC-M90W	1
1	VPH1226-001	Cushion (L)		1
2	VPH1227-001	" (R)		1
3	VPD5072-J02	Carton	RC-M90W	1
	" -J03	"	RC-M90JW	1
4	VHPJ109-039	White Paper		1
5	OPGA085-06505	Poly Bag	for Unit	1
6	VPH4106-001	Door Protector		1
7	VPK4136-004	Spacer		1
8	QPGA012-01505	Poly Bag	for Power Cord	1
9	QPGB024-03404	"	for Instruction	1
10	V30859-007	Catalog Sack	for Warranty Card (RC-M90JW)	1
11	UM1HJ	Battery	for PX (RC-M90W)	1
	OPGA010-03003	Poly Bag	for PX (RC-M90W)	1

# Accessories

	Parts No.	Parts Name	Remarks	Q'ty
⚠ ⚠ ⚠ ⚠ ⚠	VGT12M2-J02	Cassette Tape	RC-M90W SAA } or } " " } " " } RC-M90JW	1
	V04062-001	SIEMENS Plug		1
	QMP7640-183	Power Cord		1
	QMP2540-183	"		1
	QMP1240-183	"		1
	VYA4001-00A	Head Cleaning Stick	RC-M90JW, for PX (RC-M90W)	1
	BT-20046	Special Reply Card		1
	VNC6305-001	Troubleshooting		1
	VNF0830-001	Feature Sticker		1
	VNF0835-001	"	RC-M90W	1
	VNM0830-901	Instruction Book	RC-M90JW	1
	VNM0835-901	"	RC-M90JW	1
	53866-2	Label	RC-M90W	1
	BT-20047	Warranty Card	RC-M90JW, for PX (RC-M90W)	1
	V44852-004	Plate	for Caution (RC-M90JW)	1

# JVC

VICTOR COMPANY OF JAPAN, LIMITED.

RADIO & RECORDING MACHINE DIVISION 10-1, 1-chome, Ohwatari-cho, Maebashi-city 371, Japan