

STEREO AMPLIFIER

2106

SA-6700

SA-606

SERVICE MANUAL

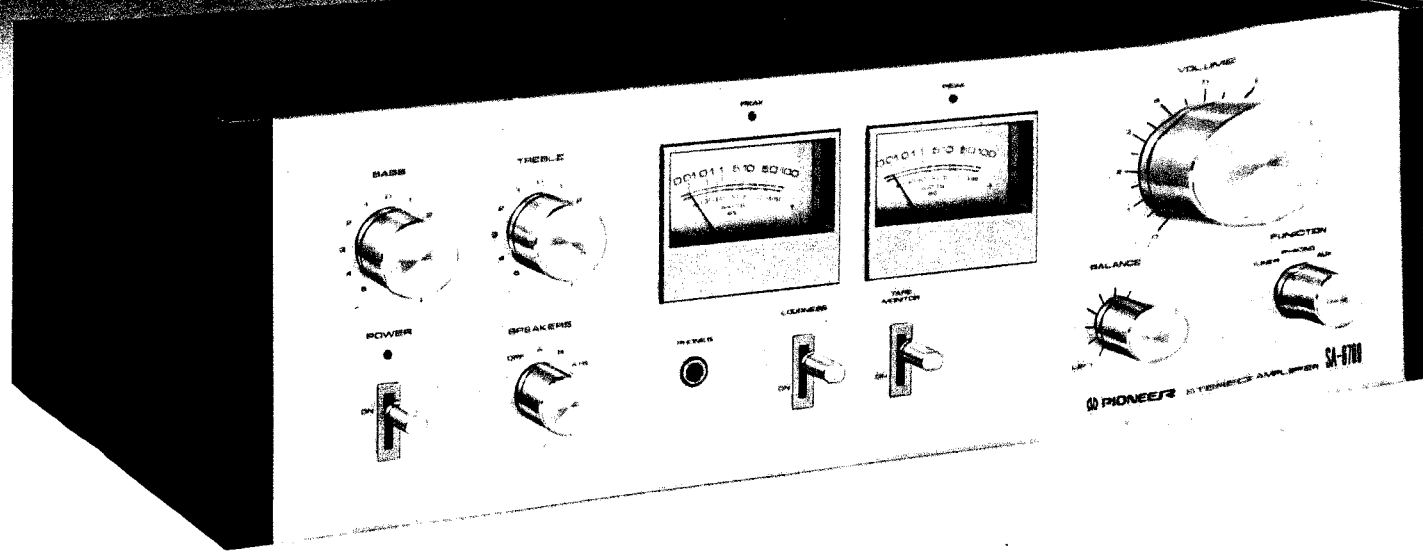

 PIONEER

21

Both Model SA-6700 and Model SA-606 have the same basic performance. SA-6700 has a wooden cover, and SA-606 has a metal cover. The following table is displayed on the SA-6700 and the SA-606.

MODEL SA-6700

Type	Voltage	Remarks
KU	120V only	U.S.A model
KC	120V only	Canada model

MODEL SA-606

Type	Voltage	Remarks
S	110V, 120V, 220V, and 240V (Switchable)	General export model
S/G	110V, 120V, 220V, and 240V (Switchable)	U.S. Military model
HG	220V and 240V (Switchable)	Europe, Oceania model

This service manual is applicable to the SA-6700/KU. When repairing the SA-606, please see the additional service manual (pp. 35–51).

CONTENTS

1.	SPECIFICATIONS	3
2.	CONNECTION DIAGRAM.....	4
3.	FRONT PANEL FACILITIES	5
4.	BLOCK DIAGRAM	7
5.	CIRCUIT DESCRIPTION	8
6.	DISASSEMBLY	11
7.	PARTS LOCATION	13
8.	ADJUSTMENTS.....	15
9.	EXPLODED VIEWS	16
10.	SCHEMATIC DIAGRAMS, P.C. BOARD PATTERNS AND PARTS LIST	
10.1	Schematic Diagram	19
10.2	Miscellanea	21
10.3	AF Assembly (GWK-111)	23

10.4	Input Terminal Assembly (GWX-154)	30
10.5	Volume Assembly (GWX-155)	31
10.6	Tone and Indicator Assembly (AWX-136)	32
11.	PACKING	34
12.	SUPPLEMENTS FOR KC TYPE	34
ADDITIONAL SERVICE MANUAL		
1.	SPECIFICATIONS	35
2.	CONTRAST OF MISCELLANEOUS PARTS	36
3.	SUPPLEMENTS FOR S AND S/G TYPES	
3.1	Exploded View	38
3.2	Schematic Diagram	39
3.3	AF Assembly (GWK-110)	41
3.4	Volume Assembly (GWX-153)	45
3.5	Input Terminal Assembly (GWX-152)	46
3.6	Tone and Indicator Assembly (AWX-135)	47
4.	SUPPLEMENTS FOR HG TYPE	
4.1	Exploded View	48
4.2	Schematic Diagram	49
4.3	DIN Connector Assembly (AWX-137)	51

1. SPECIFICATIONS

Semiconductors

ICs	2
Transistors	25
Diodes	27

Amplifier Section

Circuitry	1-st stage current mirror loaded differential amplifier, constant current loaded all- stage direct-coupled OCL.
---------------------	--

Continuous power output is 40watts* per channel, min., at 8ohms from 20Hertz to 20,000 Hertz with no more than 0.05% total harmonic distortion.

Total Harmonic Distortion (20Hertz to 20,000Hertz, from AUX)

continuous rated power output . . .	No more than 0.05%
20 watts per channel power output, 8 ohms	No more than 0.03%
1 watt per channel power output, 8 ohms	No more than 0.03%

Intermodulation Distortion (50Hertz : 7,000Hertz = 4 : 1)

continuous rated power output	No more than 0.05%
20 watts per channel power output, 8 ohms	No more than 0.02%
1 watt per channel power output, 8 ohms	No more than 0.02%

Output

Speaker	A, B, A+B
-------------------	-----------

Damping Factor

(20Hertz to 20,000Hertz, 8 ohms)	30
--	----

Input (Sensitivity/Impedance)

PHONO	2.5mV/50 kilohms
TUNER	150mV/50 kilohms
AUX	150mV/50 kilohms
TAPE PLAY	150mV/50 kilohms

Phono Overload Level (T.H.D. 0.05%, 1kHz)

PHONO	180mV
-----------------	-------

Output (Level/Impedance)

TAPE REC	150mV
--------------------	-------

Frequency Response

PHONO (RIAA Equalization)	20Hz to 20,000Hz±0.3dB
TUNER, AUX, TAPE PLAY	20Hz to 40,000Hz±2dB

Tone Control

BASS	+12dB, -10dB (100Hz)
TREBLE	+10dB, -10dB (10kHz)

Loudness Contour (Volume control set at -40dB position)	+6dB (100Hz), +3dB (10kHz)
Hum and Noise (IHF, short-circuited, A network)	
PHONO	78dB
TUNER, AUX, TAPE PLAY	95dB

Miscellaneous

Power Requirements	120V 60Hz
Power Consumption	150W(UL), 300VA(CSA) 420W(max.)
Dimensions	450(W)x148(H)x263(D) mm 17-3/4(W)x5-13/16(H)x10-3/8(D) in
Weight	Without package; 8.2 kg (18lb) With package; 9.2 kg (20lb 4 oz)

Furnished Parts

Operating instructions	1
----------------------------------	---

**Measured pursuant to Federal Trade Commission's Trade Regulation rule on Power Claims for Amplifier.*

NOTE:
Specifications and the design subject to possible modification without notice due to improvements.

2. CONNECTION DIAGRAM

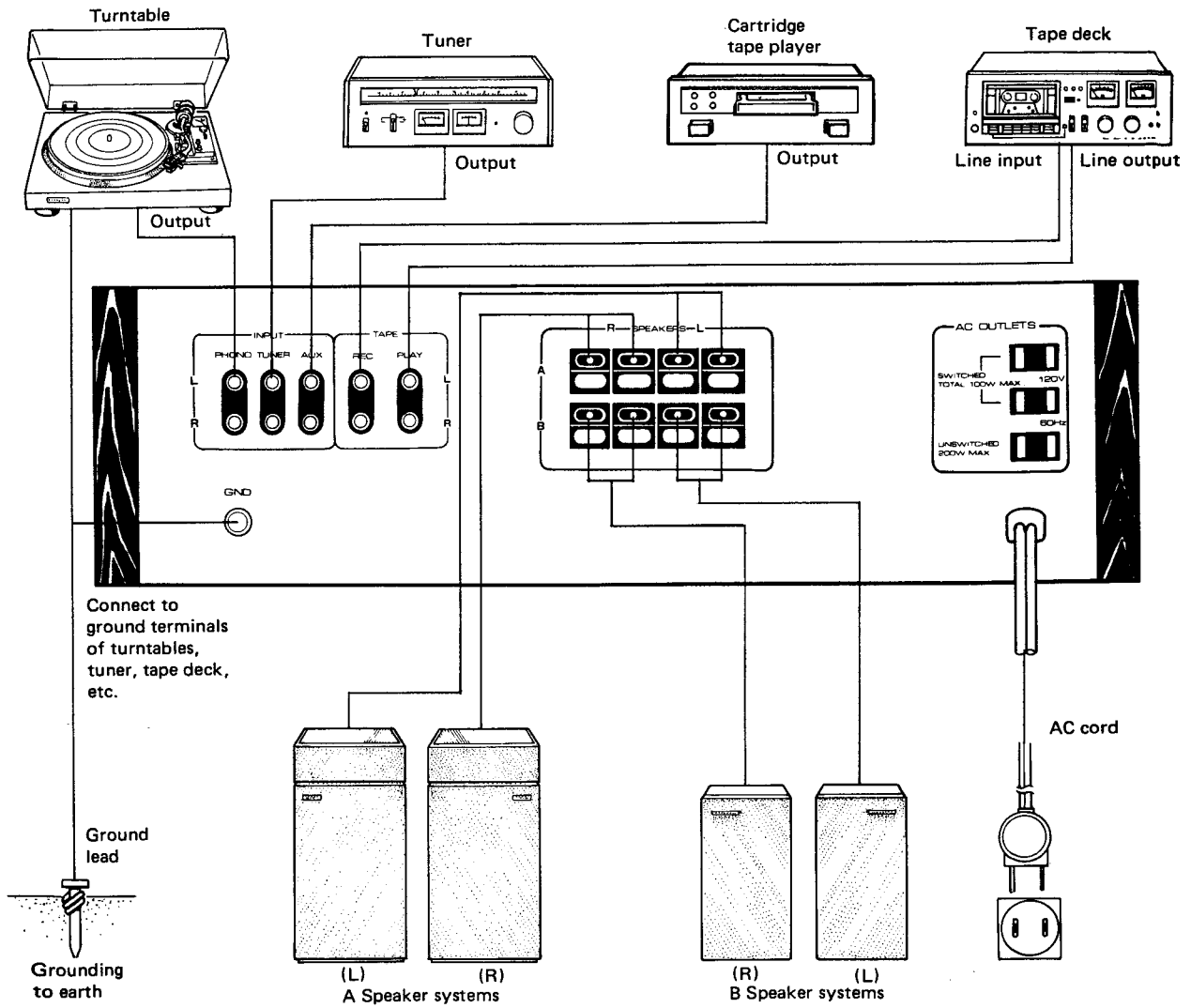

3. FRONT PANEL FACILITIES

POWER METERS

These power meters allow you to read out the rated power level when speakers with a nominal impedance of 8-ohms are connected to the amplifier's speaker terminals.

NOTE:

These values are related to the impedance of the speakers and they vary according to the frequency. In order to find out the exact output level, connect an 8-ohm dummy load instead of the speakers.

PEAK POWER INDICATORS

These lamps light up when the amplifier's output is at its peak level with 8 ohms load. Turn the VOLUME control to a lower position until the indicator does not light up continuously but only intermittently.

BASS, TREBLE CONTROLS

Adjust the bass with the BASS control and the treble with the TREBLE control. The bass and treble are strengthened when the controls are turned to the right and weakened when turned to the left.

The sound quality of the music source depends on how the sound is absorbed and reflected in the listening room and also on the characteristics of the speakers. You can use these controls to compensate accordingly and adjust the sound to your preference.

POWER SWITCH

Flip this switch to the ON position to supply power to the stereo amplifier.

SPEAKERS SWITCH

Selects speaker system operation.

OFF: Sound not obtained from speakers (when using headphones).

A: Sound obtained from speakers connected to A speaker terminals.

B: Sound obtained from speakers connected to B speaker terminals.

A + B: Sound obtained from speakers connected to both A and B speakers terminals.

NOTE:

When listening with headphones or to temporarily interrupt the speaker sound, set switch to OFF or to an unused speaker position.

PHONES JACK

When listening with stereo headphones, connect them to this jack.

NOTE:

Set the SPEAKERS switch to OFF when listening only with headphones.

LOUDNESS SWITCH

Set this switch to ON when listening at a low volume. The frequency response of the human ear varies according to the listening volume, and setting this switch to the ON position compensates for hearing response by emphasizing the bass and treble.

TAPE MONITOR SWITCH

Set switch to ON with a tape deck which is connected to the TAPE (REC and PLAY) jacks when you want to monitor the playback or recording of a tape.

NOTE:

Set this switch to the upper (off) position when listening to records or a broadcast.

VOLUME CONTROL

Use this control to adjust the output level to the speakers and headphones. Turn it clockwise to increase the output level.

FUNCTION SWITCH

Selects desired playback source.

TUNER: To listen to broadcasts with a tuner connected to the TUNER jacks.

PHONO: To play records on a turntable connected to the PHONO jacks.

AUX: To play a component connected to the AUX jacks.

NOTE:

Turn the VOLUME control down first before selecting a different function switch while the sound from one program source is being reproduced.

BALANCE CONTROL

Use this control to balance the volume of the left and right channels. First, however, tune the AM broadcast, and adjust so that the sound appears to come from somewhere exactly between the two speakers. If the sound appears to be louder on the right, it means that the volume of the right channel is higher. Turn the BALANCE control to the left and adjust. Conversely, if the sound appears to be louder on the left, it means that the volume of the left channel is higher. Therefore, turn the BALANCE control to the right and adjust.

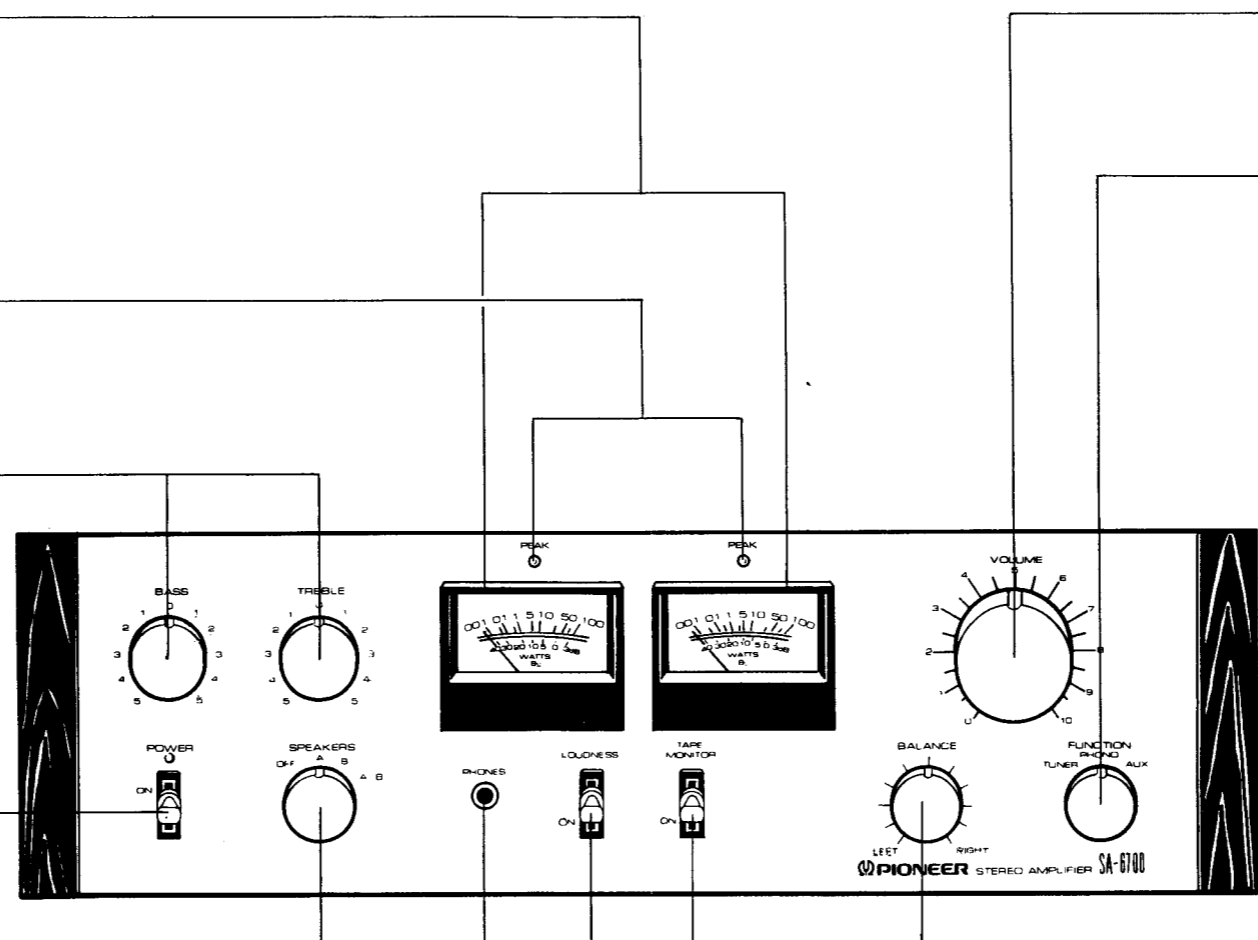

4. BLOCK DIAGRAM

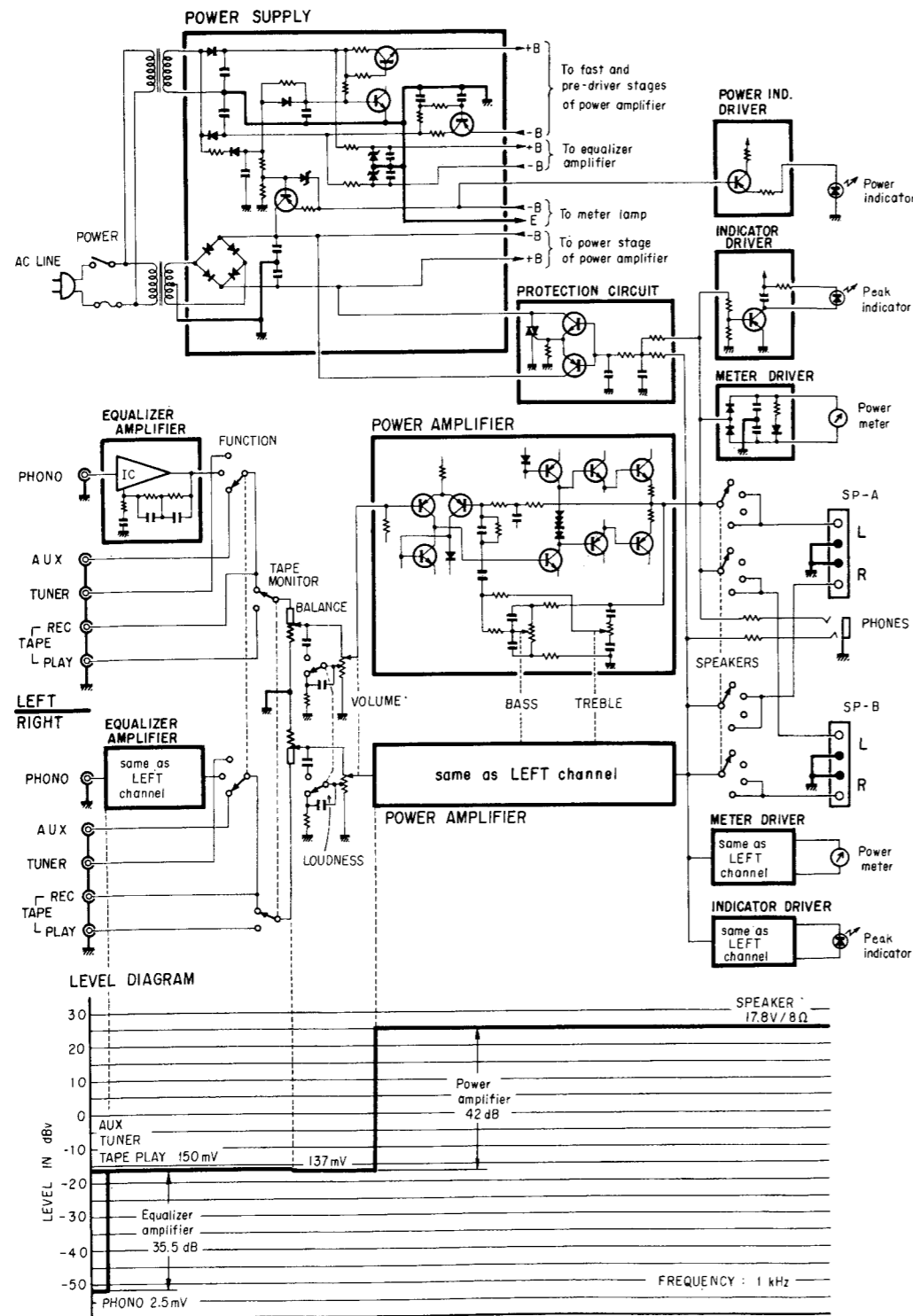

5. CIRCUIT DESCRIPTION

Equalizer Amplifier

The L channel and R channel use one high-performance IC each (TA7136P1). The circuit diagram for one channel is shown in Fig. 1.

The input signal is applied to pin 2 of the IC, and the output signal is taken from pin 6. Pin 3 is the NFB IN terminal. NFB is applied from pin 6. An equalization deviation of $\pm 0.3\text{dB}$ (20Hz ~ 20kHz) has been achieved by using 1%-tolerance metal film resistors at R_1 , R_2 and R_3 , and 2%-tolerance polystyrene film capacitors at C_2 and C_3 . The IC supply voltages are +19V and -18.5V. Allowable input is 180mVrms ($f = 1\text{kHz}$, T.H.D. = 0.05%).

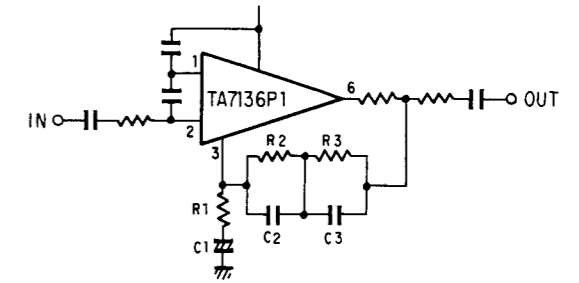

Fig. 1 Equalizer amplifier circuit

Power Amplifier

The power amplifier is an 8-transistor all-stage direct-coupled complementary OCL circuit. The tone control circuit is included in the NFB loop. Its circuit diagram is given in Fig. 2. The first stage is a PNP dual-transistor differential amplifier with current mirror load to achieve low distortion and high gain. The predriver stage has a constant-current circuit as its load to realize high gain. (A voltage gain of 42.35dB is necessary at the power amplifier to obtain a low power amplifier standard input level of 137mV and a 40W/8Ω output at

this input level. This voltage gain is obtained with the initial stage and predriver stage.)

The driver stage and output stage comprise a Darlington-connection pure complementary SEPP circuit, and perform power amplification.

Tone control is accomplished by varying the amount of power amplifier AC NFB. VR_1 controls the BASS by varying the amount of low-range NFB. VR_2 controls the TREBLE by varying the amount of high-range NFB.

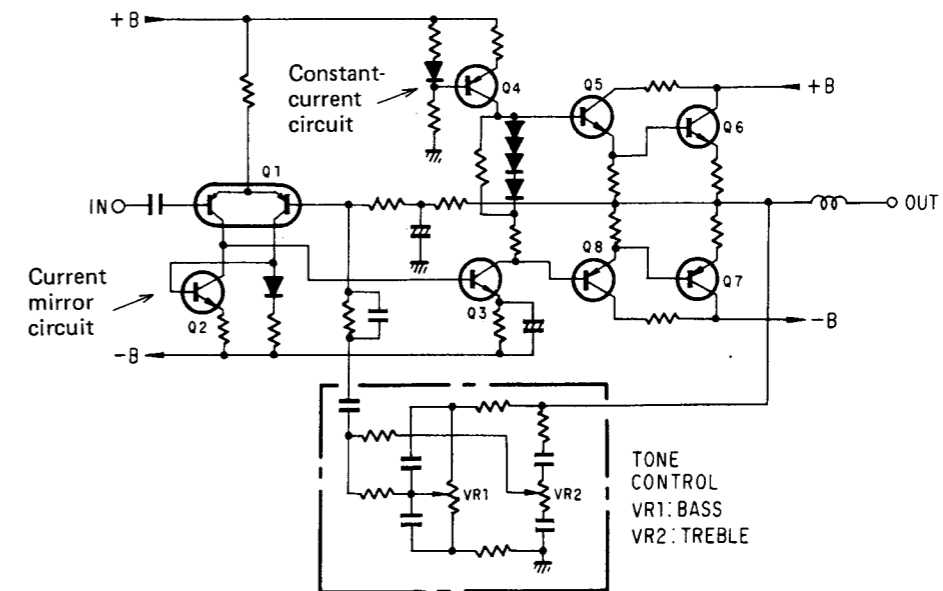

Fig. 2 Power amplifier circuit

Meter Drive Circuit

The meter is a logarithmic compression-type power meter. Direct reading from 0.01~100W (8Ω load) without range switching is possible.

The output signal of the power amplifier is passed through R₁ and full-wave rectified by D₁ and D₂ to a DC voltage (E_o) corresponding to the signal level (Fig. 3). When the output signal of the power amplifier is small, and E_o ≤ V_F, (D₃ forward voltage ≐ 0.6V), the forward resistance of D₃ becomes high and current (I) becomes I ≐ I_B. When the output signal of the power amplifier is large, and E_o > V_F, the forward resistance of D₃ becomes low, and current (I) becomes I = I_A + I_B.

Since the current (I_A) flowing in D₃ increases with an increase in the output signal of the power amplifier, because of the I_F-V_F characteristic of D₃, the current (I_B) that flows in the meter increases logarithmically instead of linearly. The current flowing in the meter is logarithmically compressed and the meter indicates +3 to -40dB.

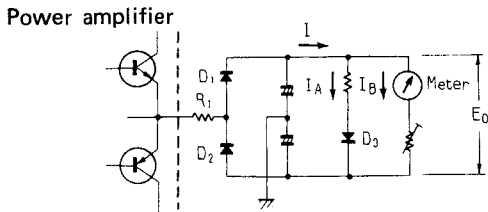

Fig. 3 Meter drive circuit

Peak Indicator Drive Circuit

This circuit lights the peak indicator when the output of the power amplifier has reached the maximum output (approximately 50W, 8Ω). Its circuit diagram is shown in Fig. 4-a.

The output voltage of the power amplifier is divided by R₁ and R₂, and applied to the base of Q₁. Therefore, when the power amplifier output peak voltage (V_{ip}) exceeds a certain value, Q₁ is

turned ON and the LED (peak indicator) lights. C₁ prevents lighting of the peak indicator when an extremely narrow pulse component has been applied.

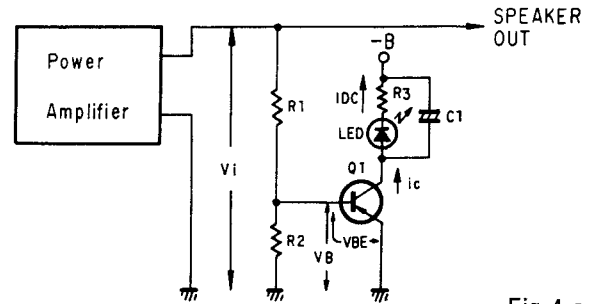

Fig. 4-a

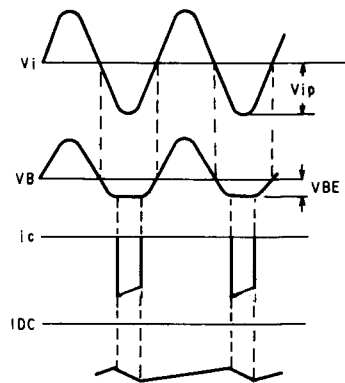

Fig. 4-b

Protection Circuit

This circuit protects the speaker when a DC voltage has been generated at the output of the power amplifier.

When a DC voltage of ±8V has been generated at the output of the power amplifier, the primary side fuse of the power transformer is blown and the supplied power is interrupted within 2 seconds. This circuit is shown in Fig. 5.

D₂₆ is a triac, and is turned ON when its gate input is a plus or minus voltage.

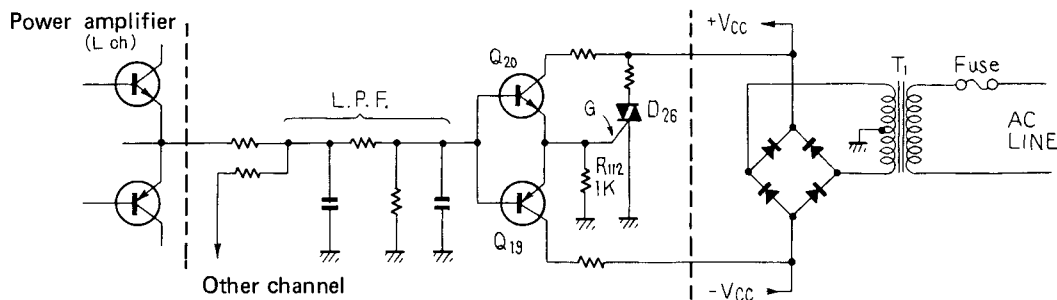

Fig. 5 Protection circuit

The output of the power amplifier is passed through an LPF, and connected to the base of Q_{19} and Q_{20} . Consequently, when the output of the power amplifier is an AC signal (audio signal), it is cut by the LPF. However, when a DC voltage is generated at the output of the power amplifier, it is passed through the LPF and applied to the base of Q_{19} and Q_{20} . Therefore, Q_{20} is turned ON when this DC voltage is positive, and Q_{19} is turned ON when it is negative. When Q_{19} or Q_{20} is turned ON, a plus or minus voltage is generated across R_{112} , this voltage is applied to the gate of D_{26} , and D_{26} conducts. Consequently, a large current flows in the power supply circuit, and the primary side fuse of the power transformer blows.

Power Supply Muting

This muting circuit cuts shock noise and residual sound generated when the power switch is turned ON and OFF. Its circuit is shown in Fig. 6.

Q_{18} is turned ON through the plus supply route ($D_{18} - R_{104} - Q_{18}$ base) from D_{18} for approximately 1 second from the instant the power switch is set to the ON position. (The voltage rise of the minus supply route from D_{19} is delayed because the time constant of R_{93} , C_{69} , R_{99} and C_{72} is larger than the plus supply route from D_{18} .) This holds the base voltage of Q_{17} at 0V, and a minus voltage of $-0.6V$ is applied to the emitter of Q_{17} through R_{102} . Therefore, +B is not supplied, and the power amplifier is held in the cut off state.

The base voltage of Q_{18} becomes $-1.5V$ approximately 1 second after the power switch is set to the ON position (because the minus supply voltage from D_{19} has risen completely). Consequently, Q_{18} is turned OFF, and the base voltage of Q_{17} becomes $+40.6V$. This supplies +B to the power amplifier first stage and predriver stage, and normal operation begins.

Immediately after the power switch is set to the OFF position, the base voltage ($-1.5V$) of Q_{18}

is discharged through the route $R_{98} - R_{97} - D_{20} - C_{72}$, and since the residual voltage of C_{68} is then applied to the base of Q_{18} through R_{104} , Q_{18} is immediately turned ON. (The discharge time constant of the minus supply route is made shorter than that of the plus supply by inserting D_{20} to make the discharge time of C_{72} faster.) Therefore, the base voltage of Q_{17} drops to 0V, and the +B supply to the power amplifier is interrupted. Moreover, the charge across C_{59} in the power amplifier is discharged through the route $C_{59} - D_{25} - R_{108} - Q_{18}$. C_{59} is discharged here to prevent the application of a reverse voltage between the emitter and base of Q_{17} immediately after the power switch is set to the OFF position.

Power Supply Circuit

Adverse effects on the Class A amplifier circuits by power supply voltage variations at high outputs are eliminated by using two power transformers, one for the Class A amplifier circuits (equalizer amplifier and power amplifier first stage and predriver stage) and one for the Class B amplifier circuits (power amplifier driver stage and output stage).

The Class A amplifiers power supply provides DC voltages of $+47V$ and $-46V$ by full-wave rectification. These are dropped to $+19V$ and $-18.5V$, respectively, through a zener diode and CR filter and supplied to the equalizer amplifier. They are dropped to $\pm 40V$ by a transistor through a ripple filter and supplied to the power amplifier first stage and predriver stage.

The Class B amplifier's power supply provides DC voltages of $\pm 40V$ by center-tap bridge rectification, and supplies these voltages to the power amplifier driver stage and output stage. Moreover, the $-40V$ is dropped to $-7.5V$ by a transistor constant-voltage circuit and supplied to the meter lamp.

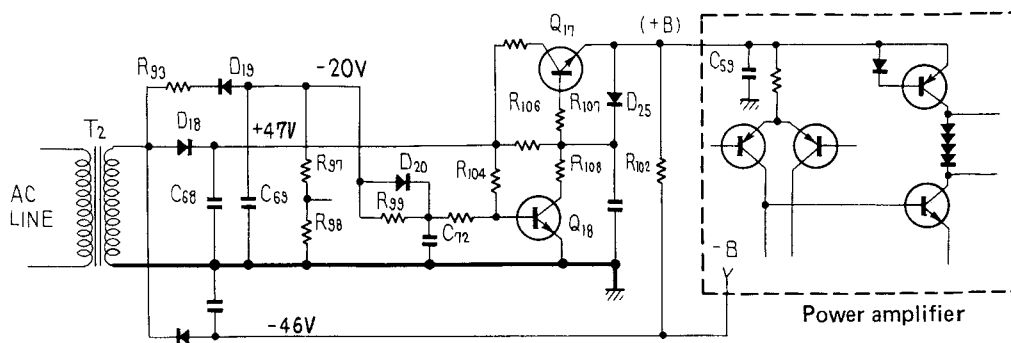

Fig. 6 Power supply circuit

6. DISASSEMBLY

Side Boards and Top Board

1. Remove the 4 screws (①~④), and remove the left and right-hand side boards.
2. Remove the 2 screws (⑤~⑥), and remove the top board.

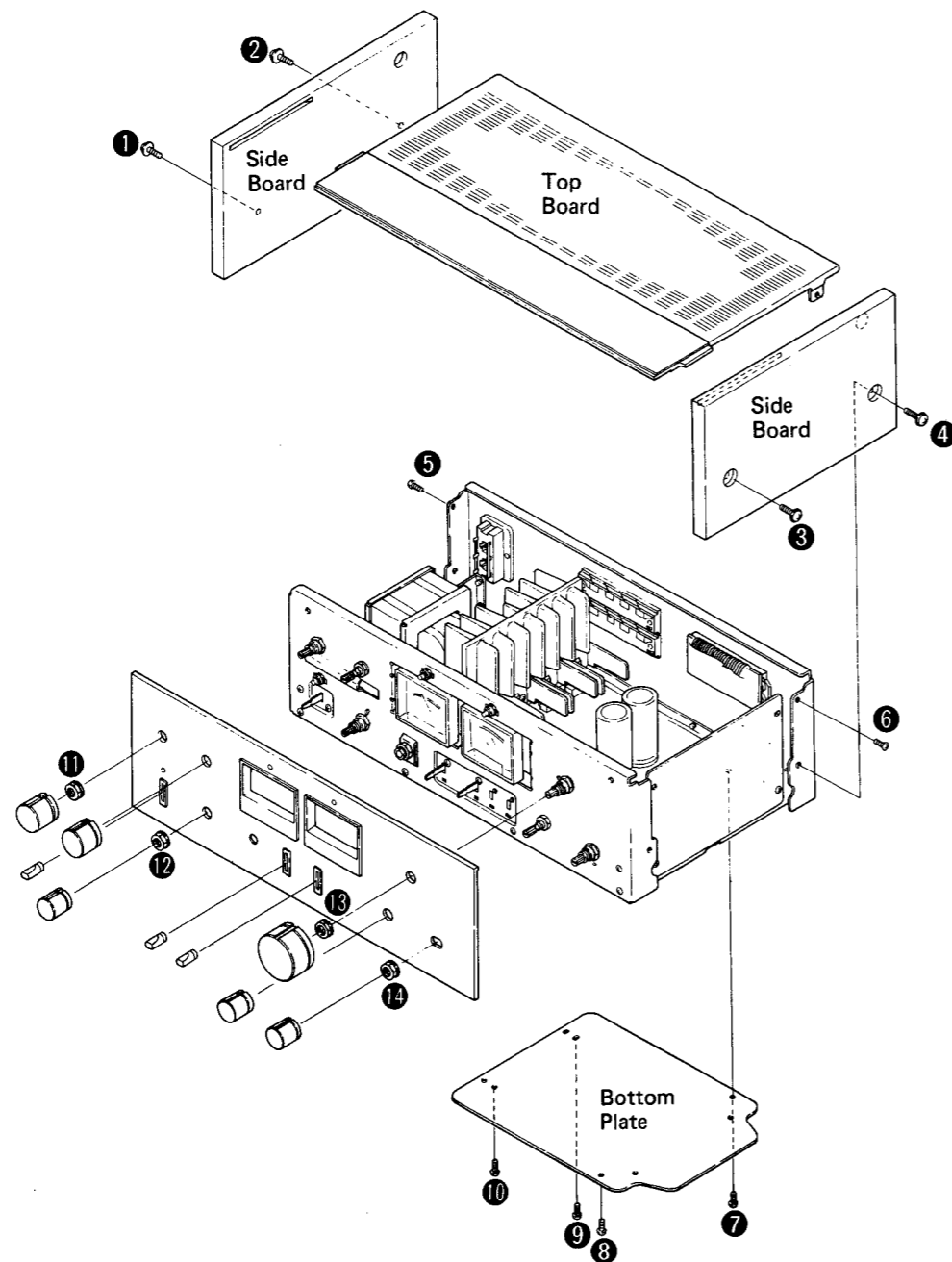

Fig. 7

Bottom Plate

Remove the 4 screws (⑦~⑩).

Front Panel

Pull off all the knobs, and remove the 4 nuts (⑪~⑭).

Heat Sink

Remove the 5 screws (⑮~⑲).

Power Transistor

Remove the 2 screws A and B.

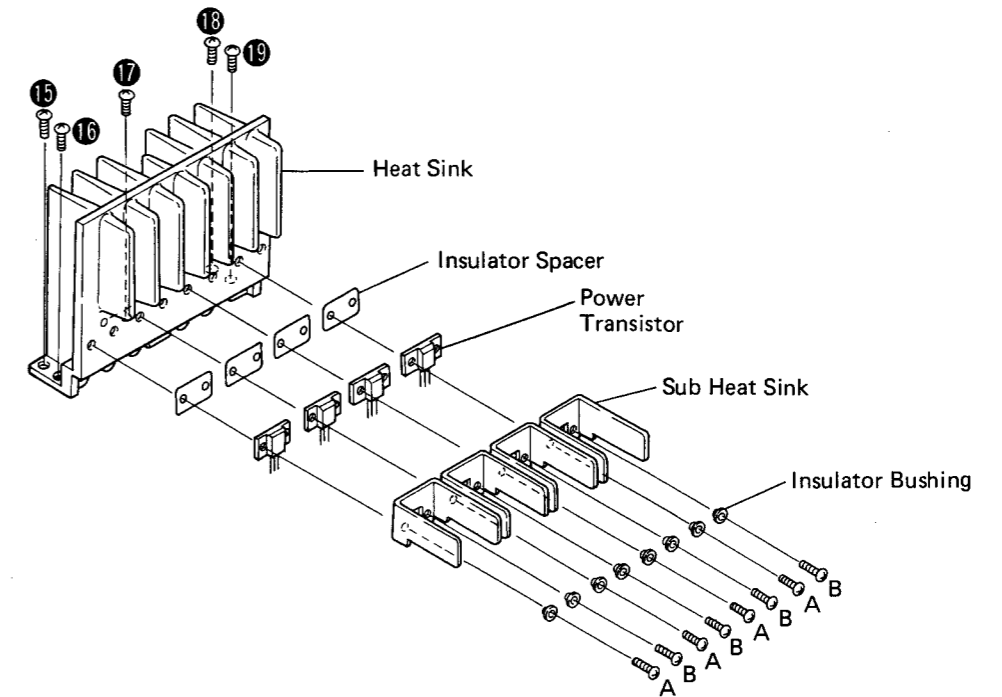

Fig. 8

Meter Lamp Replacement

1. Remove the front panel.
2. Pull the meter from the body (the meter and panel stay are attached with double sided adhesive tape through sponge).
3. Peel off the meter cover tape.
4. Peel off the reflective tape around the outside of the meter.
5. Remove the meter cover.
6. Remove the meter lamp, using a soldering iron.
7. Install the new lamp in the reverse order to removal.

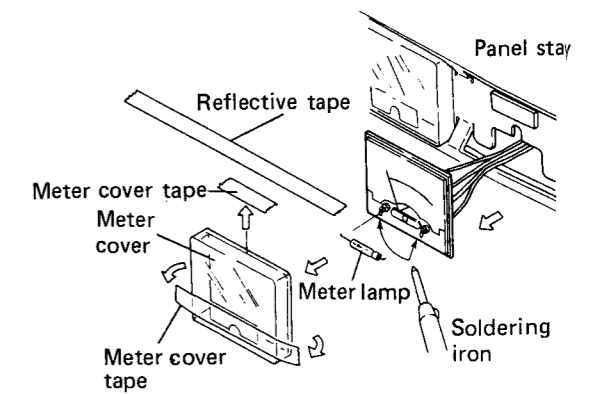

Fig. 9 Meter lamp replacement

7. PARTS LOCATION

Front Panel View

Knob
AAB-179

Front panel assembly
ANB-589

Knob
AAB-178

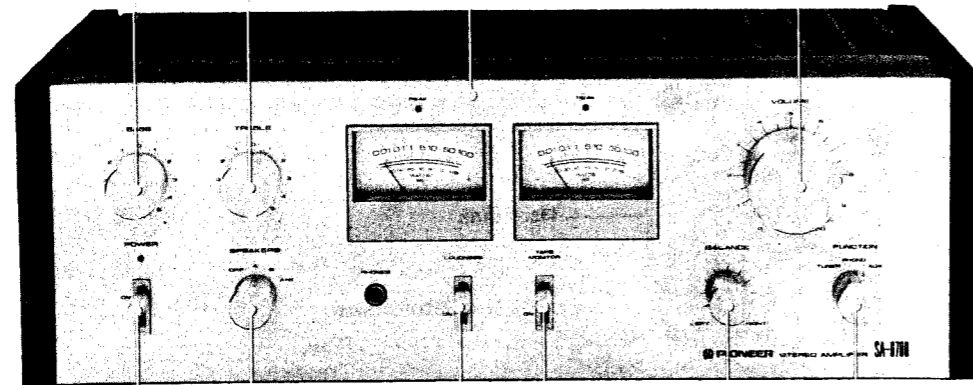

Lever knob assembly
AAD-129

Knob
AAB-180

Lever knob assembly
AAD-129

Knob
AAB-180

Front View with Panel Removed

Variable resistor 100k Ω
(TREBLE)
ACT-117

Variable resistor 100k Ω
(BASS)
ACT-117

Power meter
AAW-069

LED (PEAK ind.)
AEL-307

Variable resistor 250k Ω
(VOLUME)
ACV-184

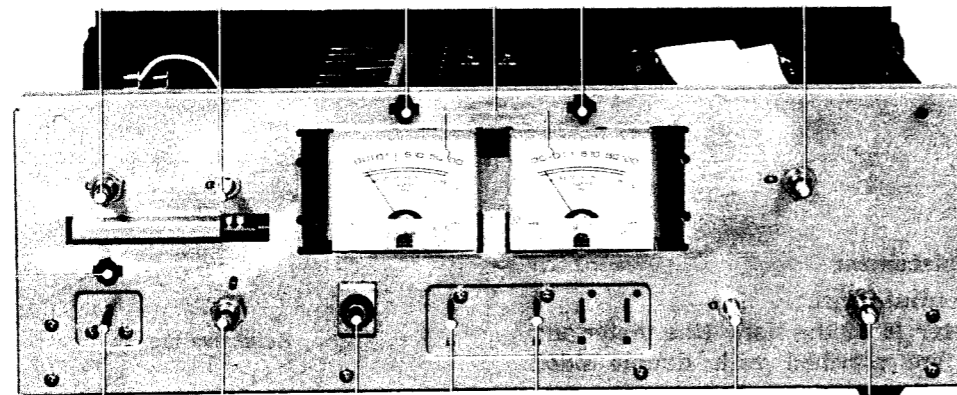

LED (POWER ind.)
AEL-308

Lever switch (POWER)
ASK-066

Rotary switch (SPEAKERS)
ASB-051

Phone jack (PHONES)
K72-026

Rotary switch (FUNCTION)
ASD-071

Variable resistor 500k Ω -HB
(BALANCE)
ACT-118

Lever switch (TAPE MONITOR)
ASK-122

Lever switch (LOUDNESS)
ASK-122

Top View

Power transformer
ATT-487

Fuse 3A
AEK-101

AF assembly
GWK-111

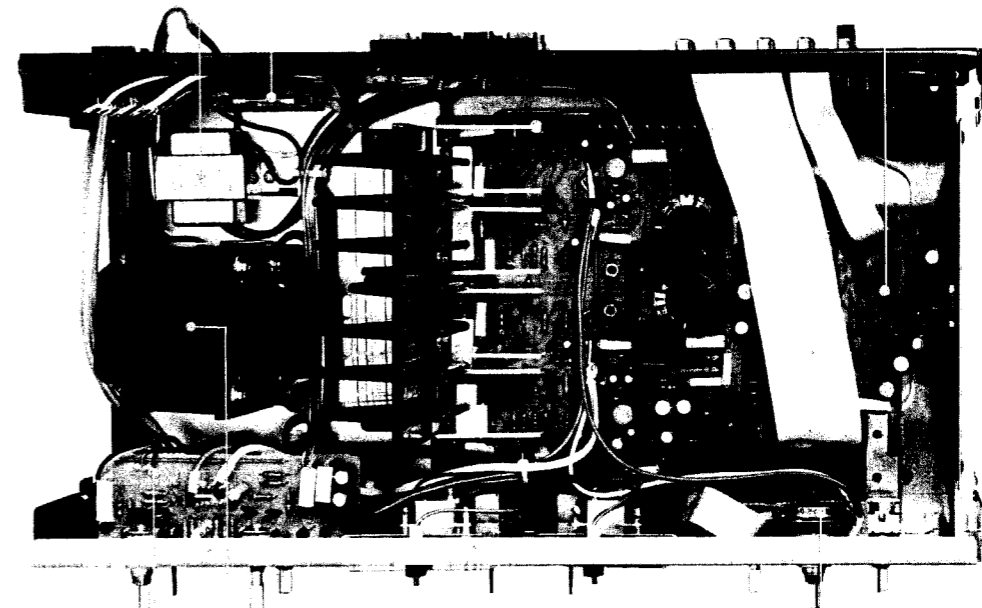

Tone and indicator assembly
AWX-136

Power transformer
AAT-483

Volume assembly
GWX-155

Rear Panel View

Terminal (INPUT)
AKB-028

Terminal (TAPE)
AKB-045

AC socket (AC OUTLETS)
AKP-005

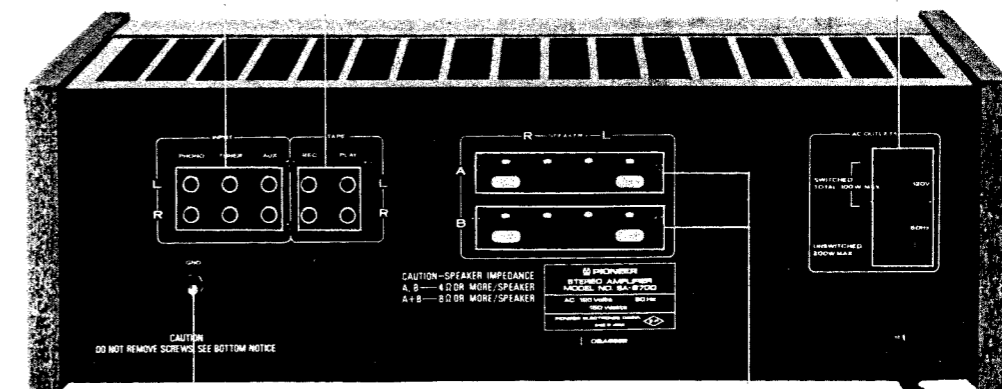

Terminal (GND)
AKE-031

Terminal (SPEAKERS)
AKE-026

8. ADJUSTMENTS

Idle Current Adjustment

1. Set the VOLUME controls to the minimum position, and set the SPEAKER switch to the "A" position.
2. Connect an 8Ω load resistor to speaker terminal A.
3. Connect a DC voltmeter between TP_2 (+) and TP_1 (-) (L channel) of Fig.10. Connect the DC voltmeter between TP_3 (+) and TP_4 (-) at the R channel.
4. Set the power switch to the ON position, and check if the DC voltmeter reading is within the $10 \sim 70\text{mV}$ range. When the voltmeter reading is below 10mV , cut jumper (A) for L channel. Cut jumper (B) for R channel.
5. Disconnect the DC voltmeter, and apply a signal to the input terminals and confirm that there is no crossover distortion in the output waveform.

Meter Circuit Adjustment

1. Set the FUNCTION switch to the AUX position, and the SPEAKER switch to the A position.
2. Connect an AC voltmeter to speaker terminal A (load resistance not connected), and connect an AF oscillator to the AUX terminal, through ATT.
3. Adjust the input level for a reading of 6.32V at the AC voltmeter.
4. Adjust VR_3 (L channel) and VR_4 (R channel) for a reading of -10dB at the power meter.
5. Confirm that the amount of change in the power meter reading almost coincides with the amount of change of ATT when ATT is changed. (Confirm at 0dB , -10dB , -20dB , -30dB , -40dB)

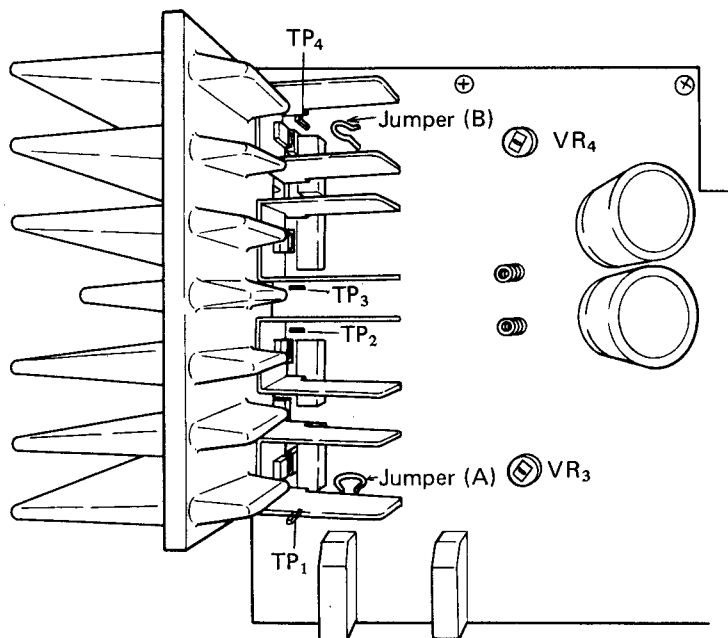
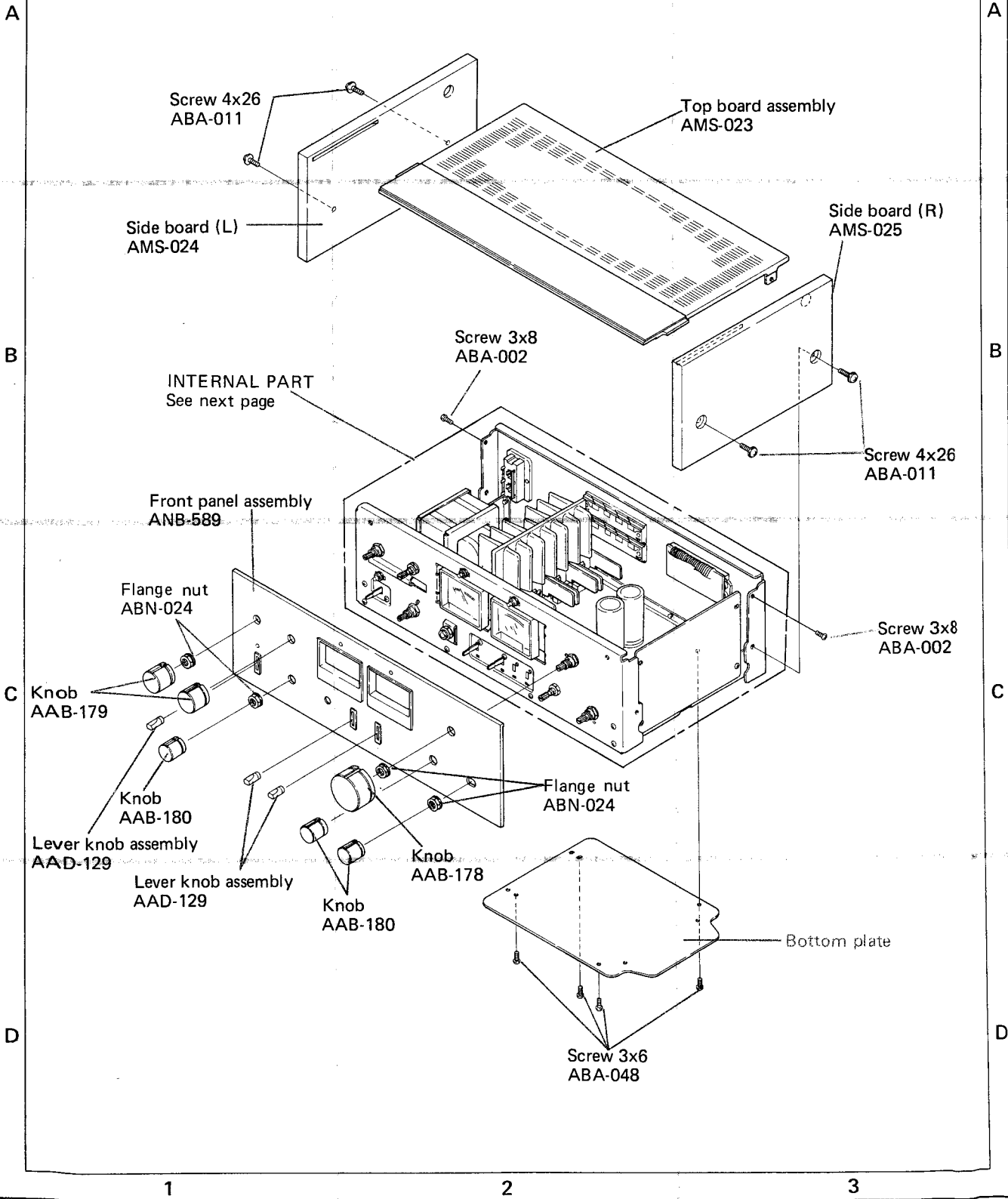

Fig. 10

9. EXPLODED VIEWS

NOTE:
Part indicated in green type cannot be supplied.

External Part



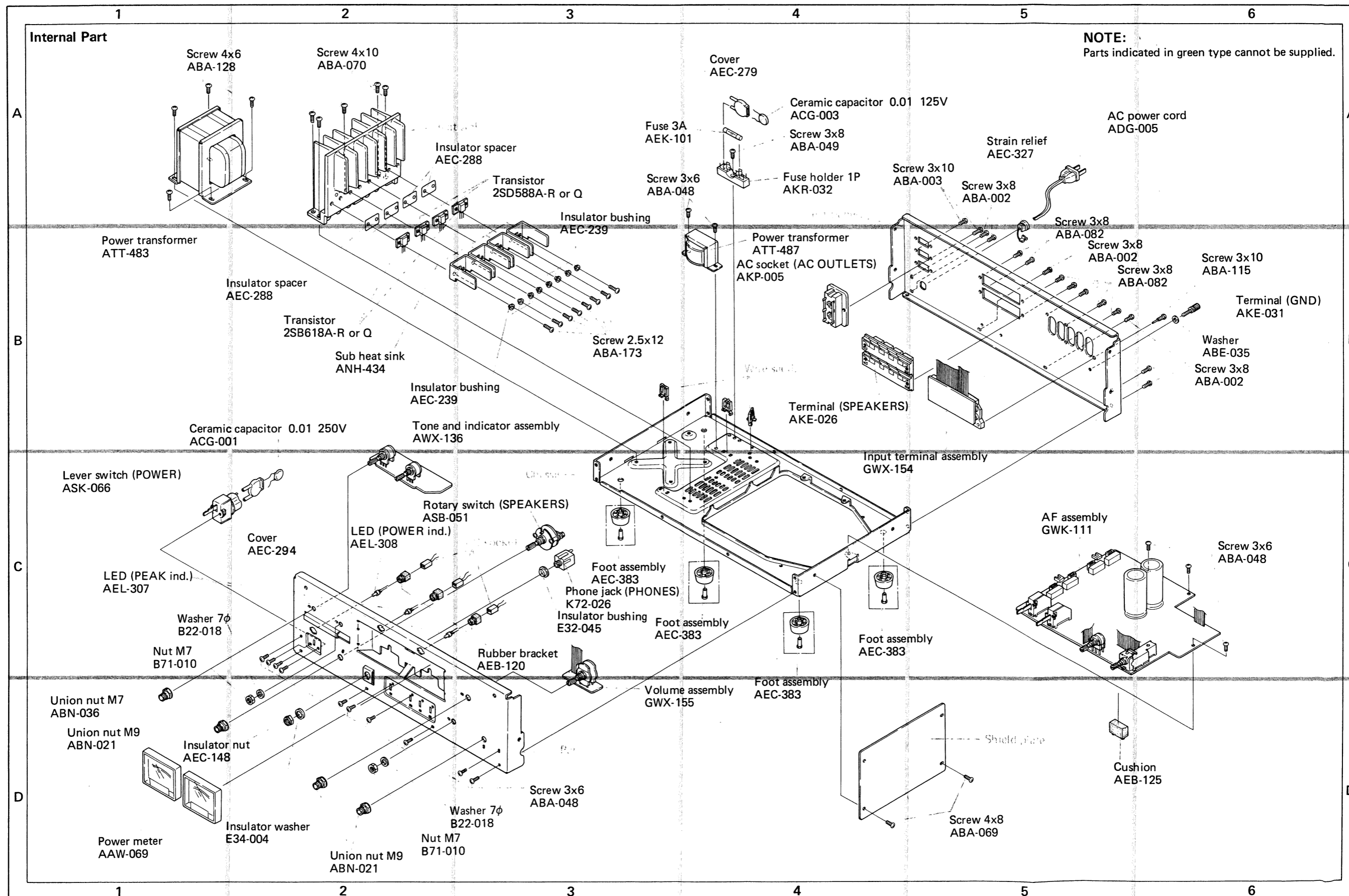

10. SCHEMATIC DIAGRAMS, P.C.BOARD PATTERNS AND PARTS LIST

10.1 SCHEMATIC DIAGRAM

NOTE:
The indicated semiconductors are representative ones only. Other alternative semiconductors may be used and are listed in the parts list.

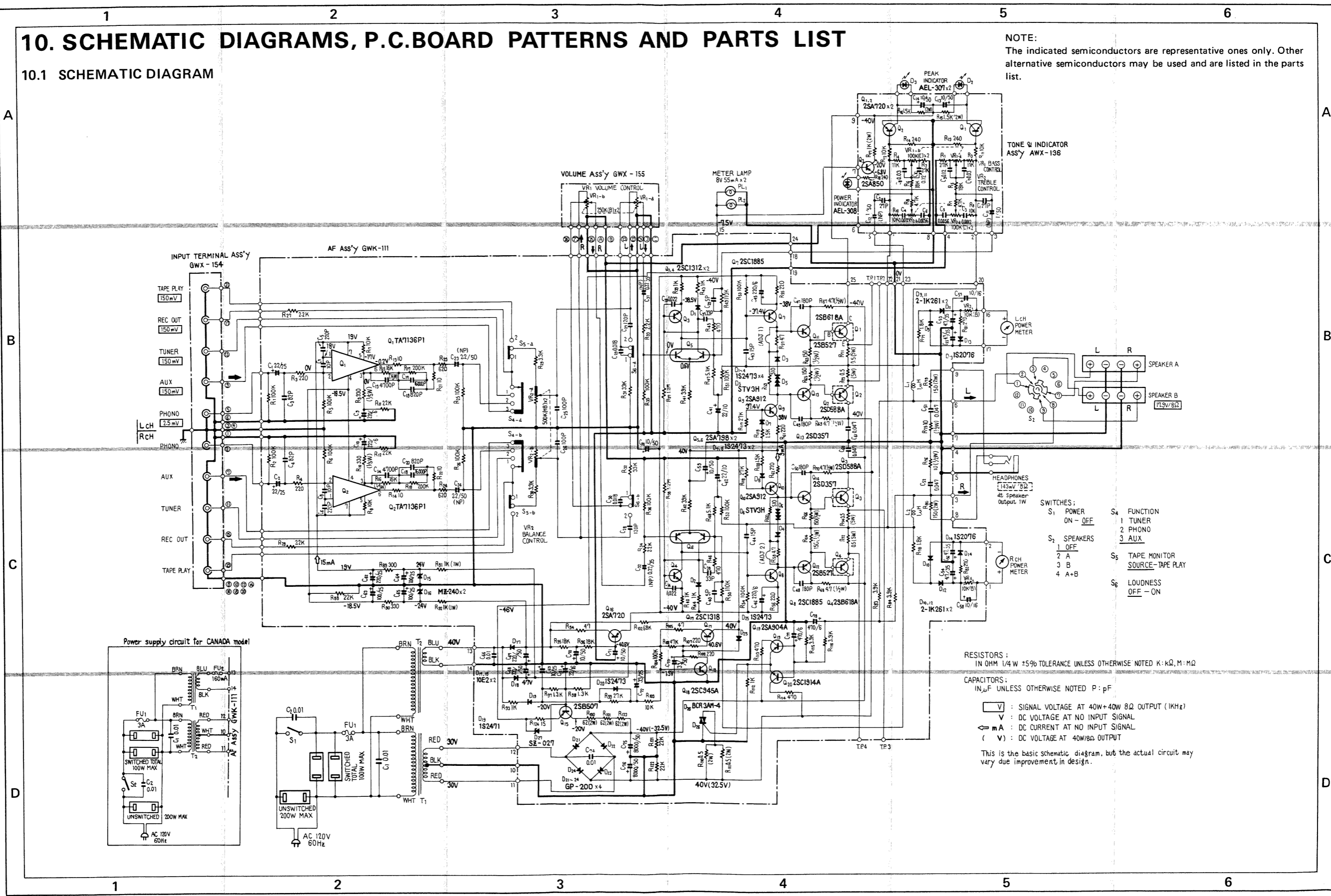

- SWITCHES:
- S₁ POWER ON - OFF
 - S₂ SPEAKERS
 - 1 OFF
 - 2 A
 - 3 B
 - 4 A+B
 - S₅ TAPE MONITOR SOURCE - TAPE PLAY
 - S₆ LOUDNESS OFF - ON

RESISTORS:
IN OHM 1/4 W ±5% TOLERANCE UNLESS OTHERWISE NOTED K:KΩ, M:MΩ

CAPACITORS:
IN μF UNLESS OTHERWISE NOTED P: pF

- V : SIGNAL VOLTAGE AT 40W+40W 8Ω OUTPUT (1KHz)
- V : DC VOLTAGE AT NO INPUT SIGNAL
- mA : DC CURRENT AT NO INPUT SIGNAL
- (V) : DC VOLTAGE AT 40W/8Ω OUTPUT

This is the basic schematic diagram, but the actual circuit may vary due to improvement in design.

10.2 MISCELLANEA

NOTE:

- Capacitors: in μF unless otherwise noted p:pF
- Resistors: in Ω , $\frac{1}{4}W$ unless otherwise noted k:k Ω , M:M Ω

Miscellaneous Parts

SWITCHES

Symbol	Part No.	Description
S1	ASK-066	Lever switch (POWER)
S2	ASB-051	Rotary switch (SPEAKERS)

TRANSFORMERS

Symbol	Part No.	Description
T1	ATT-483	Power transformer
T2	ATT-487	Power transformer

CAPACITORS

Symbol	Part No.	Description
C1	ACG-003	Ceramic 0.01 125V
C2	ACG-001	Ceramic 0.01 250V

SEMICONDUCTORS

Symbol	Part No.	Description
D1	AEL-308	LED (Power indicator)
D2	AEL-307	LED (Peak indicator)
D3	AEL-307	LED (Peak indicator)
Q1	2SB618A-R or Q	Transistor
Q2	2SD588A-R or Q	Transistor
Q3	2SD588A-R or Q	Transistor
Q4	2SB618A-R or Q	Transistor

OTHERS

Symbol	Part No.	Description
FU1	AEK-101	Fuse 3A
PL1	AEL-101	Lamp (with in power meter)
PL2	AEL-101	Lamp (with in power meter)
	AAW-069	Power meter
	AKE-026	Terminal (SPEAKERS)
	K72-026	Phone jack (PHONES)
	AKE-031	Terminal (GND)
	AKP-005	AC socket (OUTLET)
	AKR-032	Fuse holder
	ADG-005	AC power cord
	AWX-136	Tone and indicator assembly
	GWK-111	AF assembly
	GWX-155	Volume assembly
	GWX-154	Input terminal assembly

NOTE:

List of changed parts information will be furnished whenever necessary and you are requested to amend parts number in this parts list.

List of Changed Parts for Factory Modification

Symbol	Part No.	Description

External Appearance of Transistors and IC

2SA720
2SC1318
2SC945A

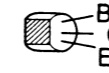

2SB618A
2SD588A

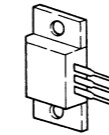

2SC1885
2SA912



2SB527
2SD357

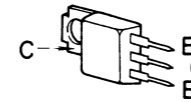

2SC1312
2SA904A
2SC1914A



2SB507

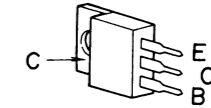

TA7136P1

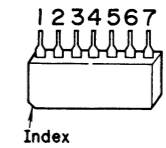

2SA798

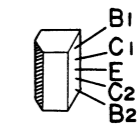

2SA850



Circuit Diagram of IC

TA7136P1

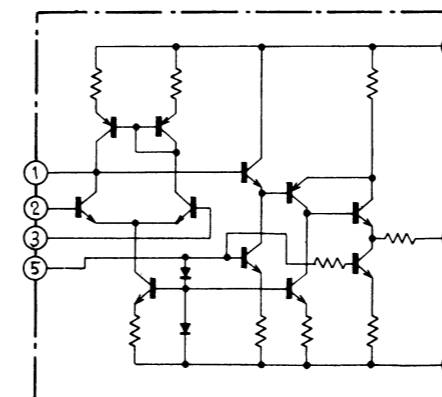

10.3 AF ASSEMBLY (GWK-111)

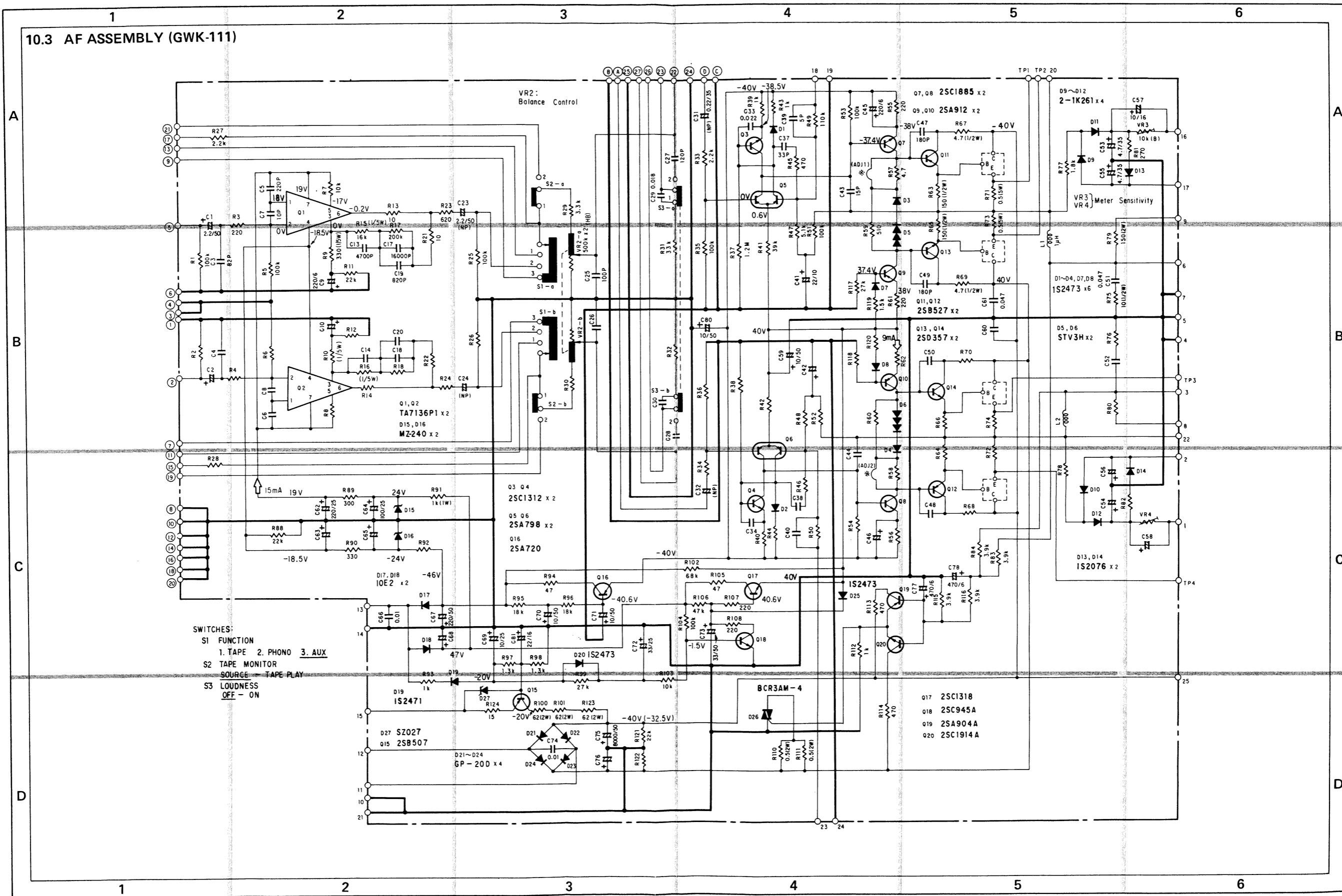

SWITCHES:
 S1 FUNCTION
 1. TAPE 2. PHONO 3. AUX
 S2 TAPE MONITOR
 SOURCE TAPE PLAY
 S3 LOUDNESS
 OFF - ON

- 017 2SC1318
- 018 2SC945A
- 019 2SA904A
- 020 2SC1914A

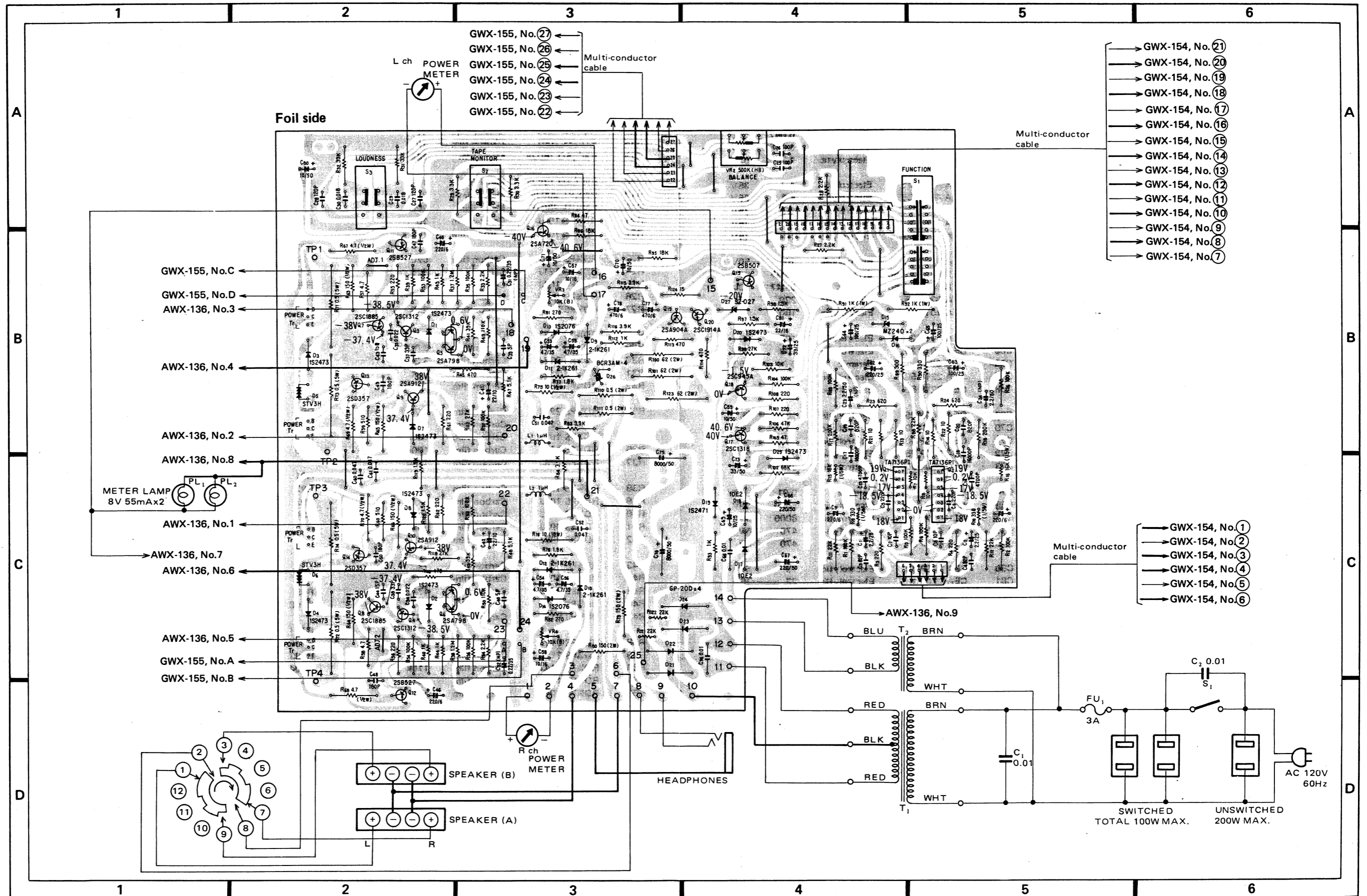

1
2
3
4
5
6

A

B

C

D

- GWX-155, No. 27
- GWX-155, No. 26
- GWX-155, No. 25
- GWX-155, No. 24
- GWX-155, No. 23
- GWX-155, No. 22

- GWX-155, No. C
- GWX-155, No. D
- AWX-136, No. 3
- AWX-136, No. 4
- AWX-136, No. 2
- AWX-136, No. 8
- METER LAMP 8V 55mA x 2
- AWX-136, No. 1
- AWX-136, No. 7
- AWX-136, No. 6
- AWX-136, No. 5
- GWX-155, No. A
- GWX-155, No. B

- GWX-154, No. 21
- GWX-154, No. 20
- GWX-154, No. 19
- GWX-154, No. 18
- GWX-154, No. 17
- GWX-154, No. 16
- GWX-154, No. 15
- GWX-154, No. 14
- GWX-154, No. 13
- GWX-154, No. 12
- GWX-154, No. 11
- GWX-154, No. 10
- GWX-154, No. 9
- GWX-154, No. 8
- GWX-154, No. 7

- GWX-154, No. 1
- GWX-154, No. 2
- GWX-154, No. 3
- GWX-154, No. 4
- GWX-154, No. 5
- GWX-154, No. 6

Parts List of AF Assembly (GWK-111)

SWITCHES

Symbol	Part No.	Description
S1	ASD-071	Rotary switch (FUNCTION)
S2	ASK-122	Lever switch (TAPE MONITOR)
S3	ASK-122	Lever switch (LOUDNESS)

CAPACITORS

Symbol	Part No.	Description
C1	CSZA 2R2M 25	Electrolytic 2.2 25V
C2	CSZA 2R2M 25	Electrolytic 2.2 25V
C3	CCDSL 820K 50	Ceramic 82p 50V
C4	CCDSL 820K 50	Ceramic 82p 50V
C5	CCDSL 221K 50	Ceramic 220p 50V
C6	CCDSL 221K 50	Ceramic 220p 50V
C7	CCDSL 100K 50	Ceramic 10p 50V
C8	CCDSL 100K 50	Ceramic 10p 50V
C9	CEA 221P 6	Electrolytic 220 6V
C10	CEA 221P 6	Electrolytic 220 6V
C13	CQSA 472G 50	Polystyrene 4700p 50V
C14	CQSA 472G 50	Polystyrene 4700p 50V
C17	CQPA 163G 50	Polypropylene 0.016 50V
C18	CQPA 163G 50	Polypropylene 0.016 50V
C19	CKDYB 821K 50	Ceramic 820p 50V
C20	CKDYB 821K 50	Ceramic 820p 50V
C23	ACH-323	Electrolytic 2.2 50V
C24	ACH-323	Electrolytic 2.2 50V
C25	CCDSL 101K 50	Ceramic 100p 50V
C26	CCDSL 101K 50	Ceramic 100p 50V
C27	CCDSL 121K 50	Ceramic 120p 50V
C28	CCDSL 121K 50	Ceramic 120p 50V
C29	CQMA 183J 50	Mylar 0.018 50V
C30	CQMA 183J 50	Mylar 0.018 50V
C31	ACH-304	Electrolytic 0.22 35V
C32	ACH-304	Electrolytic 0.22 35V
C33	CQMA 223J 50	Mylar 0.022 50V
C34	CQMA 223J 50	Mylar 0.022 50V
C37	CCDSL 330J 50	Ceramic 33p 50V
C38	CCDSL 330J 50	Ceramic 33p 50V
C39	CCDSL 050D 50	Ceramic 5p 50V
C40	CCDSL 050D 50	Ceramic 5p 50V
C41	CEA 220P 10	Electrolytic 22 10V
C42	CEA 220P 10	Electrolytic 22 10V
C43	CCDSL 150K 50	Ceramic 15p 50V
C44	CCDSL 150K 50	Ceramic 15p 50V
C45	CEA 221P 6	Electrolytic 220 6V
C46	CEA 221P 6	Electrolytic 220 6V
C47	CCDSL 181K 50	Ceramic 180p 50V
C48	CCDSL 181K 50	Ceramic 180p 50V

Symbol	Part No.	Description
C49	CCDSL 181K 50	Ceramic 180p 50V
C50	CCDSL 181K 50	Ceramic 180p 50V
C51	CKDYF 473Z 50	Ceramic 0.047 50V
C52	CKDYF 473Z 50	Ceramic 0.047 50V
C53	CEA 4R7P 35	Electrolytic 4.7 35V
C54	CEA 4R7P 35	Electrolytic 4.7 35V
C55	CEA 4R7P 35	Electrolytic 4.7 35V
C56	CEA 4R7P 35	Electrolytic 4.7 35V
C57	CEA 100P 16	Electrolytic 10 16V
C58	CEA 100P 16	Electrolytic 10 16V
C59	CEA 100P 50	Electrolytic 10 50V
C60	CKDYF 473Z 50	Ceramic 0.047 50V
C61	CKDYF 473Z 50	Ceramic 0.047 50V
C62	CEA 221P 25	Electrolytic 220 25V
C63	CEA 101P 25	Electrolytic 100 25V
C64	CEA 101P 25	Electrolytic 100 25V
C65	CEA 101P 25	Electrolytic 100 25V
C66	ACG-004	Ceramic 0.01 150V
C67	CEA 221P 50	Electrolytic 220 50V
C68	CEA 221P 50	Electrolytic 220 50V
C69	CEA 100P 25	Electrolytic 10 25V
C70	CEA 100P 50	Electrolytic 10 50V
C71	CEA 100P 50	Electrolytic 10 50V
C72	CEA 330P 25	Electrolytic 33 25V
C73	CEA 330P 50	Electrolytic 33 50V
C74	ACG-004	Ceramic 0.01 150V
C75	ACH-082	Electrolytic 8000 50V
C76	ACH-082	Electrolytic 8000 50V
C77	CEA 471P 6	Electrolytic 470 6V
C78	CEA 471P 6	Electrolytic 470 6V
C80	CEA 100P 50	Electrolytic 10 50V
C81	CEA 220P 16	Electrolytic 22 16V

RESISTORS

Symbol	Part No.	Description
VR2	ACT-118	Variable resistor 500k-HB (BALANCE)
VR3	C92-049	Semi-fixed 10k-B
VR4	C92-049	Semi-fixed 10k-B
R1	RD½PS 104J NL	Carbon film 100k
R2	RD½PS 104J NL	Carbon film 100k
R3	RD½PS 221J	Carbon film 220
R4	RD½PS 221J	Carbon film 220
R5	RD½PS 104J NL	Carbon film 100k
R6	RD½PS 104J NL	Carbon film 100k
R7	RD½VS 103J	Carbon film 10k

Symbol	Part No.	Description	Symbol	Part No.	Description
R8	RD½VS 103J	Carbon film 10k	R61	RD½PS 221J	Carbon film 220
R9	RN½SQ 3300F	Metal film 330 ½W	R62	RD½PS 221J	Carbon film 220
R10	RN½SQ 3300F	Metal film 330 ½W	R63	RD½PS 151J	Carbon film 150 ½W
R11	RD½PS 223J	Carbon film 22k	R64	RD½PS 151J	Carbon film 150 ½W
R12	RD½PS 223J	Carbon film 22k	R65	RD½PS 151J	Carbon film 150 ½W
R13	RD½PS 100J	Carbon film 10	R66	RD½PS 151J	Carbon film 150 ½W
R14	RD½PS 100J	Carbon film 10	R67	RD½PSF 4R7J	Carbon film 4.7 ½W
R15	RN½SQ 1602F	Metal film 16k ½W	R68	RD½PSF 4R7J	Carbon film 4.7 ½W
R16	RN½SQ 1602F	Metal film 16k ½W	R69	RD½PSF 4R7J	Carbon film 4.7 ½W
R17	RN½PT 2003F	Metal film 200k	R70	RD½PSF 4R7J	Carbon film 4.7 ½W
R18	RN½PT 2003F	Metal film 200k	R71	RT5B 0R5K	Wire wound 0.5 5W
R21	RD½PS 100J	Carbon film 10	R72	RT5B 0R5K	Wire wound 0.5 5W
R22	RD½PS 100J	Carbon film 10	R73	RT5B 0R5K	Wire wound 0.5 5W
R23	RD½PS 621J	Carbon film 620	R74	RT5B 0R5K	Wire wound 0.5 5W
R24	RD½PS 621J	Carbon film 620	R75	RD½PS 100J	Carbon film 10 ½W
R25	RD½PS 104J	Carbon film 100k	R76	RD½PS 100J	Carbon film 10 ½W
R26	RD½PS 104J	Carbon film 100k	R77	RD½PS 182J	Carbon film 1.8k
R27	RD½PS 222J	Carbon film 2.2k	R78	RD½PS 182J	Carbon film 1.8k
R28	RD½PS 222J	Carbon film 2.2k	R79	RS2P 151J	Metal oxide 150 2W
R29	RD½PS 332J	Carbon film 3.3k	R80	RS2P 151J	Metal oxide 150 2W
R30	RD½PS 332J	Carbon film 3.3k	R81	RD½PS 271J	Carbon film 270
R31	RD½PS 333J	Carbon film 33k	R82	RD½PS 271J	Carbon film 270
R32	RD½PS 333J	Carbon film 33k	R83	RD½PS 392J	Carbon film 3.9k
R33	RD½PS 222J	Carbon film 2.2k	R84	RD½PS 392J	Carbon film 3.9k
R34	RD½PS 222J	Carbon film 2.2k	R88	RD½PS 223J	Carbon film 22k
R35	RD½PS 104J	Carbon film 100k	R89	RD½PS 301J	Carbon film 300
R36	RD½PS 104J	Carbon film 100k	R90	RD½PS 331J	Carbon film 330
R37	RD½PS 125J	Carbon film 1.2M	R91	RS1P 102J	Metal oxide 1k 1W
R38	RD½PS 125J	Carbon film 1.2M	R92	RS1P 102J	Metal oxide 1k 1W
R39	RD½PS 102J	Carbon film 1k	R93	RD½PS 102J	Carbon film 1k
R40	RD½PS 102J	Carbon film 1k	R94	RD½PS 470J	Carbon film 47
R41	RD½PS 393J	Carbon film 39k	R95	RD½PS 183J	Carbon film 18k
R42	RD½PS 393J	Carbon film 39k	R96	RD½PS 183J	Carbon film 18k
R43	RD½PS 102J	Carbon film 1k	R97	RD½PS 132J	Carbon film 1.3k
R44	RD½PS 102J	Carbon film 1k	R98	RD½PS 132J	Carbon film 1.3k
R45	RD½PS 471J	Carbon film 470	R99	RD½PS 273J	Carbon film 27k
R46	RD½PS 471J	Carbon film 470	R100	RS2P 620J	Metal oxide 62 2W
R47	RD½PS 512J	Carbon film 5.1k	R101	RS2P 620J	Metal oxide 62 2W
R48	RD½PS 512J	Carbon film 5.1k	R102	RD½PS 683J	Carbon film 68k
R49	RD½PS 114J	Carbon film 110k	R103	RD½PS 103J	Carbon film 10k
R50	RD½PS 114J	Carbon film 110k	R104	RD½PS 104J	Carbon film 100k
R51	RD½PS 104J	Carbon film 100k	R105	RD½PS 470J	Carbon film 47
R52	RD½PS 104J	Carbon film 100k	R106	RD½PS 473J	Carbon film 47k
R53	RD½PS 104J	Carbon film 100k	R107	RD½PS 221J	Carbon film 220
R54	RD½PS 104J	Carbon film 100k	R108	RD½PS 221J	Carbon film 220
R55	RD½PS 221J	Carbon film 220	R110	RN2H 0R5K	Metal film 0.5 2W
R56	RD½PS 221J	Carbon film 220	R111	RN2H 0R5K	Metal film 0.5 2W
R57	RD½PS 4R7J	Carbon film 4.7	R112	RD½PS 102J	Carbon film 1k
R58	RD½PS 4R7J	Carbon film 4.7	R113	RD½PS 471J	Carbon film 470
R59	RD½PS 511J	Carbon film 510	R114	RD½PS 471J	Carbon film 470
R60	RD½PS 511J	Carbon film 510	R115	RD½PS 392J	Carbon film 3.9k

10.4 INPUT TERMINAL ASSEMBLY (GWX-154)

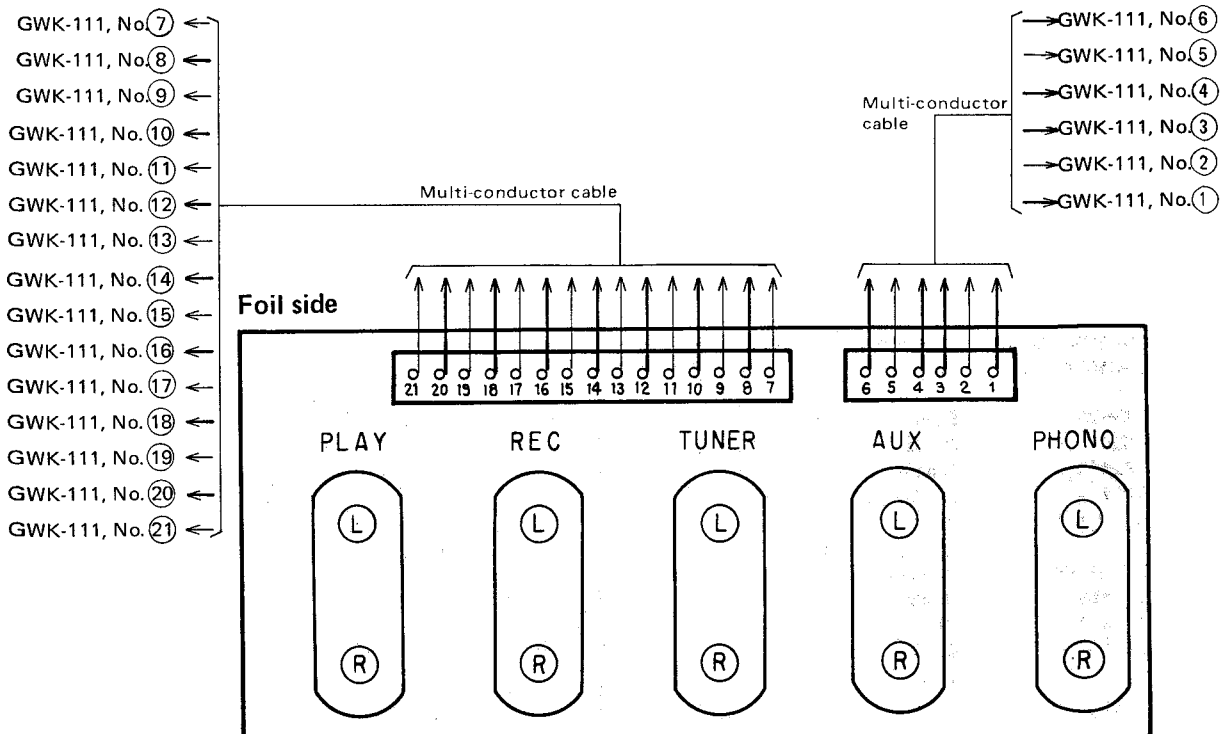
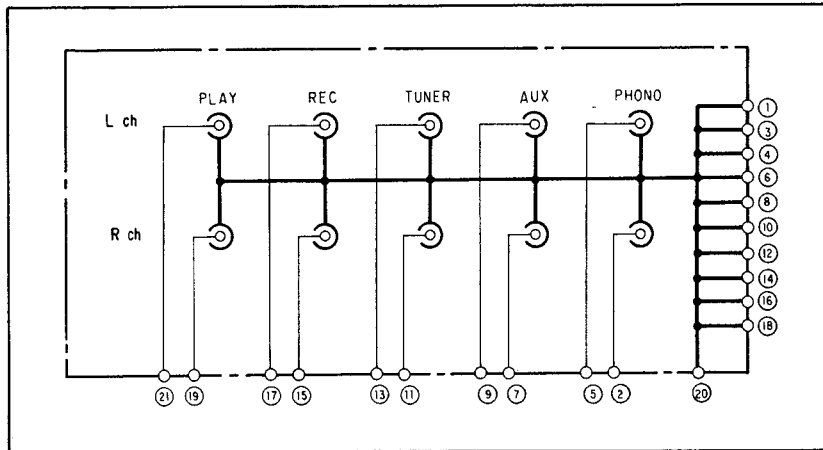

Parts List

Symbol	Part No.	Description
	AKB-045	Terminal (TAPE)
	AKB-028	Terminal (INPUT)

10.5 VOLUME ASSEMBLY (GWX-155)

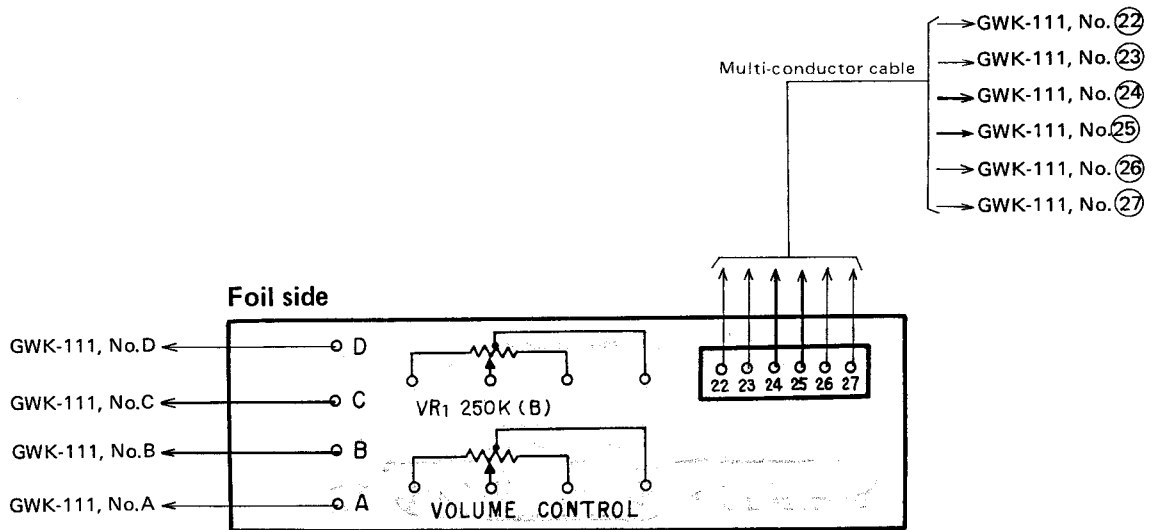
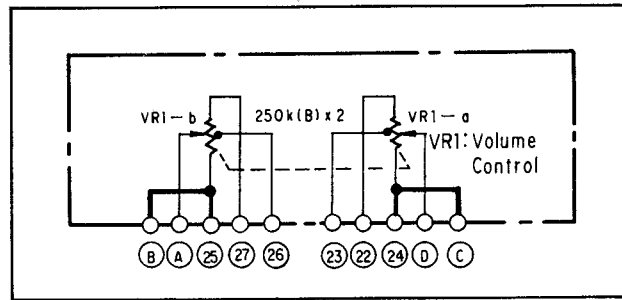

Parts List

Symbol	Part No.	Description
VR1	ACV-184	Variable resistor 250k-B (VOLUME)

10.6 TONE AND INDICATOR ASSEMBLY (AWX-136)

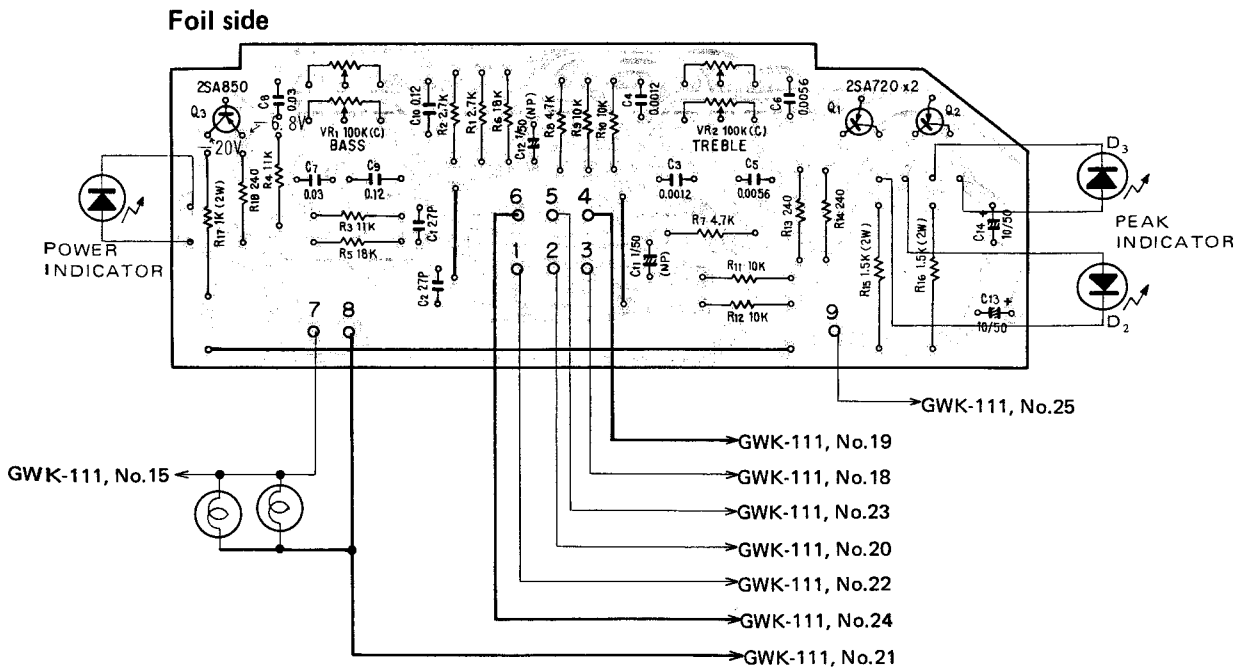
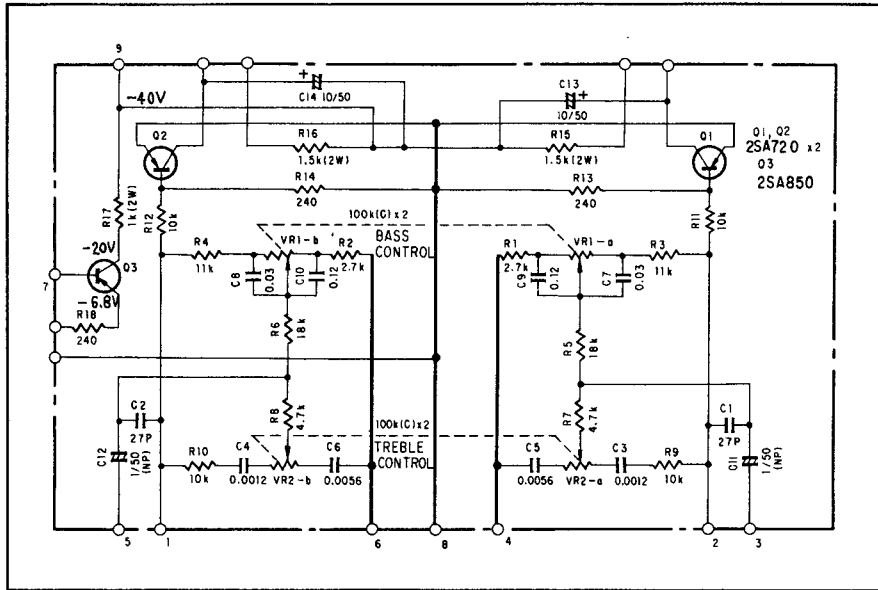

11. PACKING

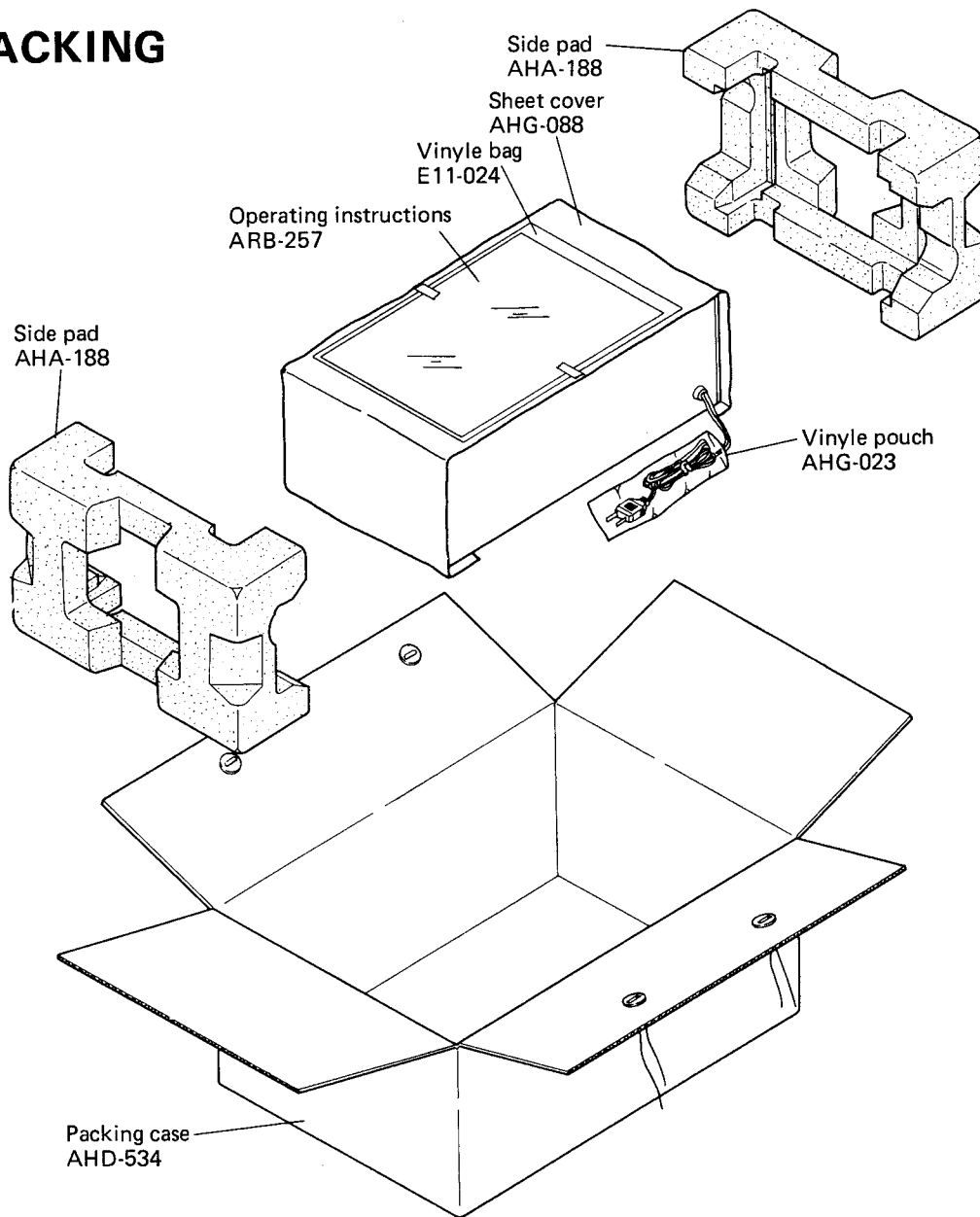

12. SUPPLEMENTS FOR KC TYPE

Model SA-6700/KC is the same as SA-6700/KU with exception of descriptions in this supplements.

Contrast of Miscellaneous Parts

Symbol	Description	Part No.		Remarks
		KU type	KC type	
T1	Power transformer	ATT-483	ATT-484	for C1 for C2 for FU2
FU2	Fuse 160mA	AEK-408	
C1	Ceramic 0.01 125V	ACG-003	ACG-014	
C2	Ceramic 0.01 250V	ACG-001	
	Ceramic 0.01 125V	ACG-014	
	Cover	AEC-279	AEC-365	
	Cover	AEC-294	AEC-365	
	Fuse holder 1P	K91-008	
	Packing case	AHD-534	AHD-535	

ADDITIONAL

 **PIONEER®**

Service Manual

STEREO AMPLIFIER

SA-606 S S/G HG

NOTE:

- For detailed instructions on adjustments, circuit descriptions, exploded views, etc., please refer to this Service Manual (pp. 3–34).

1. SPECIFICATIONS

The specifications for Model SA-606 is the same as Model SA-6700 except for following sections;

Amplifier Section

Input (Sensitivity/Impedance)

TAPE PLAY (DIN connector) 150mV/50 kilohms
(HG type only)

Output (Level/Impedance)

TAPE REC (DIN connector) 30mV/80 kilohms
(HG type only)

Hum and Noise (DIN, continuous power/50mW)

PHONO. 58dB/66dB
AUX. 60dB/85dB

Miscellaneous

Power Requirements AC 110/120/220/240V
(switchable) 50/60Hz (S and S/G types)
AC 220/240V (switchable), 50/60Hz
(HG type only)

Power Consumption 420W (max.)
(HG type only)
100W
(S and S/G types)

Dimensions 420(W)x147(H)x261(D)mm
16-9/16(W)x5-13/16(H)x12-7/8(D)in

Weight Without Package; 7.5kg (16 lb 9 oz)
With Package; 8.5kg (18 lb 12 oz)

Furnished Parts (S and S/G types)

Fuse 2A 1
Fuse 3A 1

2. CONTRAST OF MISCELLANEOUS PARTS

CONTRAST OF MISCELLANEOUS PARTS

SWITCHES

Symbol	Description	Part No.			
		KU type	S type	S/G type	HG type
S1	Lever switch (POWER)	ASK-066	ASK-097	ASK-097	ASA-505
S3	Plug in selector	AKX-037
	Plug in selector with fuse holder	AKR-031	AKR-031

CAPACITORS

Symbol	Description	Part No.			
		KU type	S type	S/G type	HG type
C1	Ceramic 0.01 125V	ACG-003
	Ceramic 0.01 250V	ACG-001	ACG-001	ACG-001
C2	Ceramic 0.01 250V	ACG-001	ACG-001	ACG-001

P.C. BOARD ASSEMBLIES

Symbol	Description	Part No.			
		KU type	S type	S/G type	HG type
	AF assembly	GWK-111	GWK-110	GWK-110	GWK-110
	Input terminal assembly	GWX-154	GWX-152	GWX-152	GWX-152
	Volume assembly	GWX-155	GWX-153	GWX-153	GWX-153
	Tone and indicator assembly	AWX-136	AWX-135	AWX-135	AWX-135
	DIN connector assembly	AWX-137

FUSES

Symbol	Description	Part No.			
		KU type	S type	S/G type	HG type
FU1	Fuse 3A	AEK-101	AEK-101	AEK-101
	Fuse 2A	AEK-103	AEK-103
	Fuse 1.25A	AEK-018
FU2	Fuse 160mA	AEK-408

OTHERS

Symbol	Description	Part No.			
		KU type	S type	S/G type	HG type
T1	Power transformer	ATT-483	ATT-485	ATT-485	ATT-486
T2	Power transformer	ATT-487	ATT-488	ATT-488	ATT-489

Symbol	Description	Part No.			
		KU type	S type	S/G type	HG type
	Fuse holder 1P	AKR-032	K91-008
	AC socket (AC OUTLET)	AKP-005	AKP-020	AKP-020
	Recessed plug (AC INLET)	AKP-008
	AC power cord	ADG-005	ADG-016	ADG-016
	Top board assembly	AMS-023
	Side board L	AMS-024
	Side board R	AMS-025
	Top cover	ANE-195	ANE-195	ANE-195
	Screw (for top cover)	ABA-079	ABA-079	ABA-079
	Power meter	AAW-069	AAW-087	AAW-087	AAW-087
	Front panel assembly	ANB-589	ANB-590	ANB-590	ANB-590
	Cushion	AEB-125
	Cover (for C1)	AEC-279	AEC-099	AEC-099	AEC-099
	Cover (for C2)	AEC-294	AEC-099	AEC-099

PACKING AND FURNISHED PARTS

Symbol	Description	Part No.			
		KU type	S type	S/G type	HG type
	Packing case	AHD-534	AHD-536	AHD-537	AHD-538
	Side pad	AHA-188	AHA-189	AHA-189	AHA-189
	Sheet cover	AHG-088	AHG-072	AHG-072	AHG-072
	Vinyl pouch	AHG-023	AHG-023	AHG-023
	Vinyl pouch (for fuse)	E11-033	E11-033
	Fuse 2A	AEK-103	AEK-103
	Fuse 3A	AEK-101	AEK-101
	Operating instructions (ENGLISH)	ARB-257	ARB-258	ARB-258	ARB-258
	Operating instructions (GERMAN/FRENCH)	ARD-119

3. SUPPLEMENTS FOR S AND S/G TYPES

3.1 EXPLODED VIEW

NOTE:

Parts indicated in green type cannot be supplied.

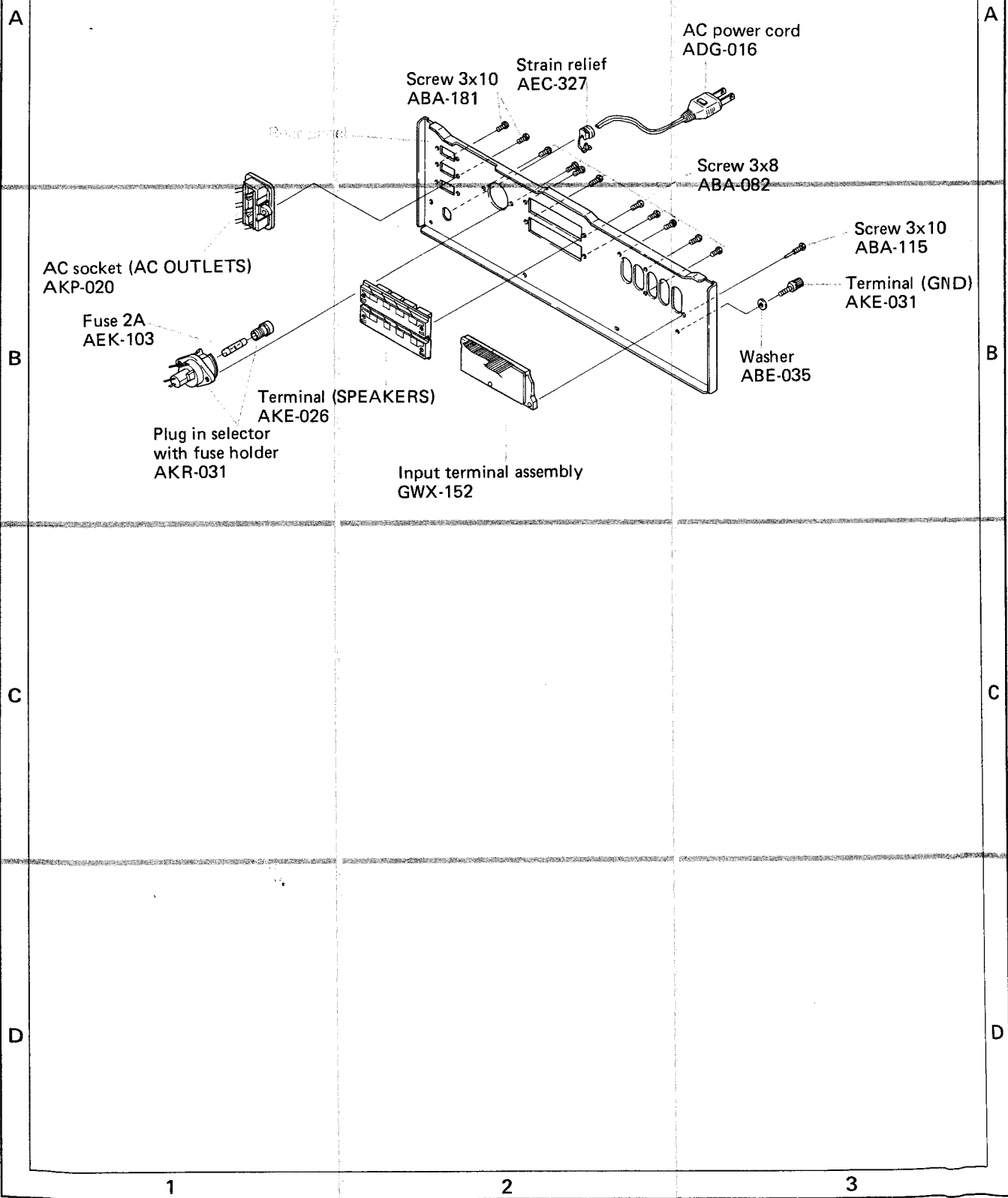

AC socket (AC OUTLETS)
AKP-020

Fuse 2A
AEK-103

Plug in selector
with fuse holder
AKR-031

Terminal (SPEAKERS)
AKE-026

Input terminal assembly
GWX-152

Screw 3x10
ABA-181

Strain relief
AEC-327

AC power cord
ADG-016

Screw 3x8
ABA-082

Screw 3x10
ABA-115

Terminal (GND)
AKE-031

Washer
ABE-035

3.2 SCHEMATIC DIAGRAM

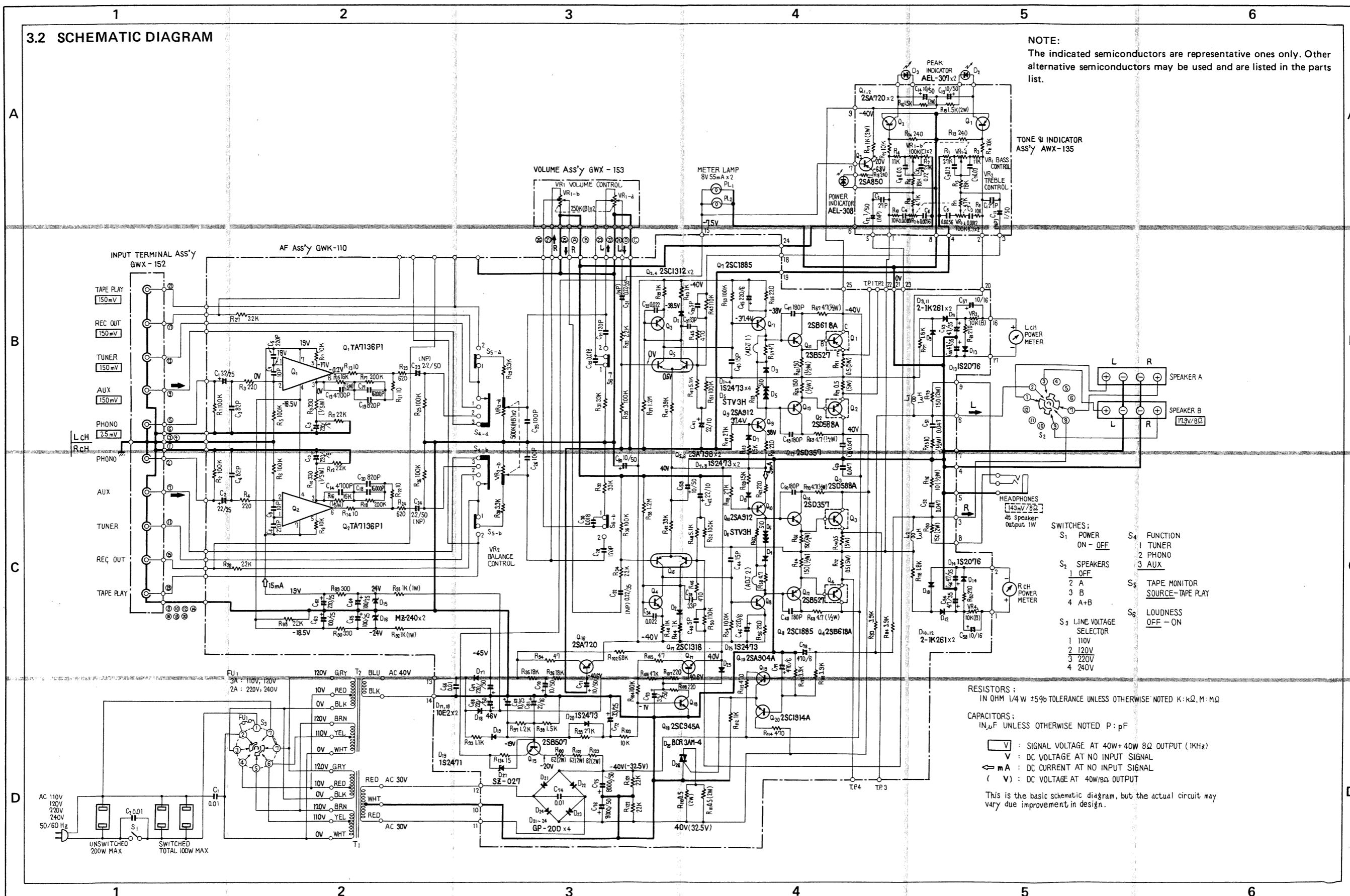

NOTE:
The indicated semiconductors are representative ones only. Other alternative semiconductors may be used and are listed in the parts list.

TONE & INDICATOR ASS'y AWX-135

- SWITCHES:
- S₁ POWER ON - OFF
 - S₂ SPEAKERS
 - 1 OFF
 - 2 A
 - 3 B
 - 4 A+B
 - S₃ TAPE MONITOR SOURCE - TAPE PLAY
 - S₄ FUNCTION
 - 1 TUNER
 - 2 PHONO
 - 3 AUX
 - S₅ LOUDNESS OFF - ON

RESISTORS:
IN OHM 1/4 W ±5% TOLERANCE UNLESS OTHERWISE NOTED K: kΩ, M: MΩ

CAPACITORS:
IN μF UNLESS OTHERWISE NOTED P: pF

- V : SIGNAL VOLTAGE AT 40W+40W 8Ω OUTPUT (1KHz)
- V : DC VOLTAGE AT NO INPUT SIGNAL
- mA : DC CURRENT AT NO INPUT SIGNAL
- (V) : DC VOLTAGE AT 40W/8Ω OUTPUT

This is the basic schematic diagram, but the actual circuit may vary due to improvement in design.

SA-606/S, S/G

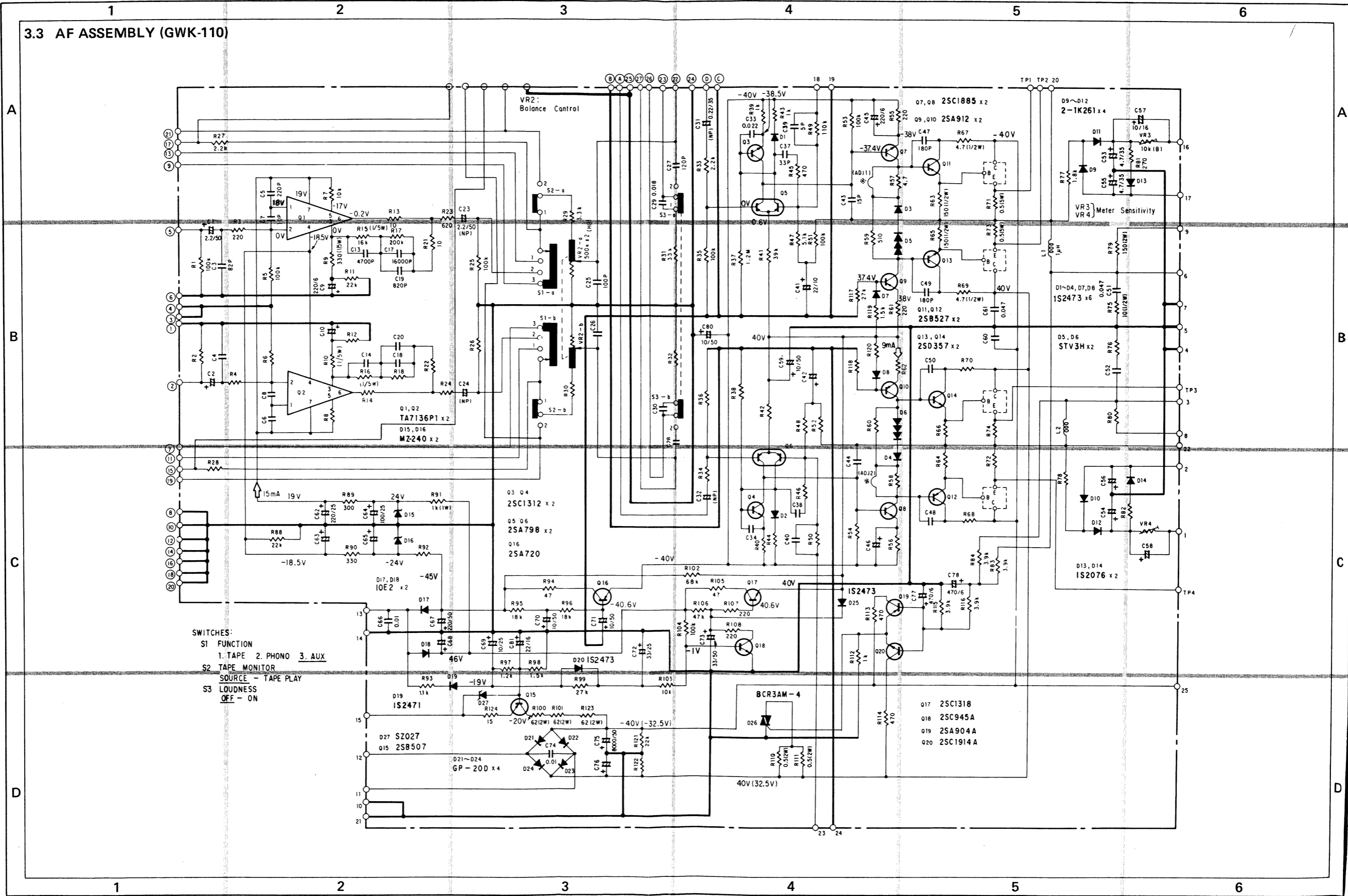

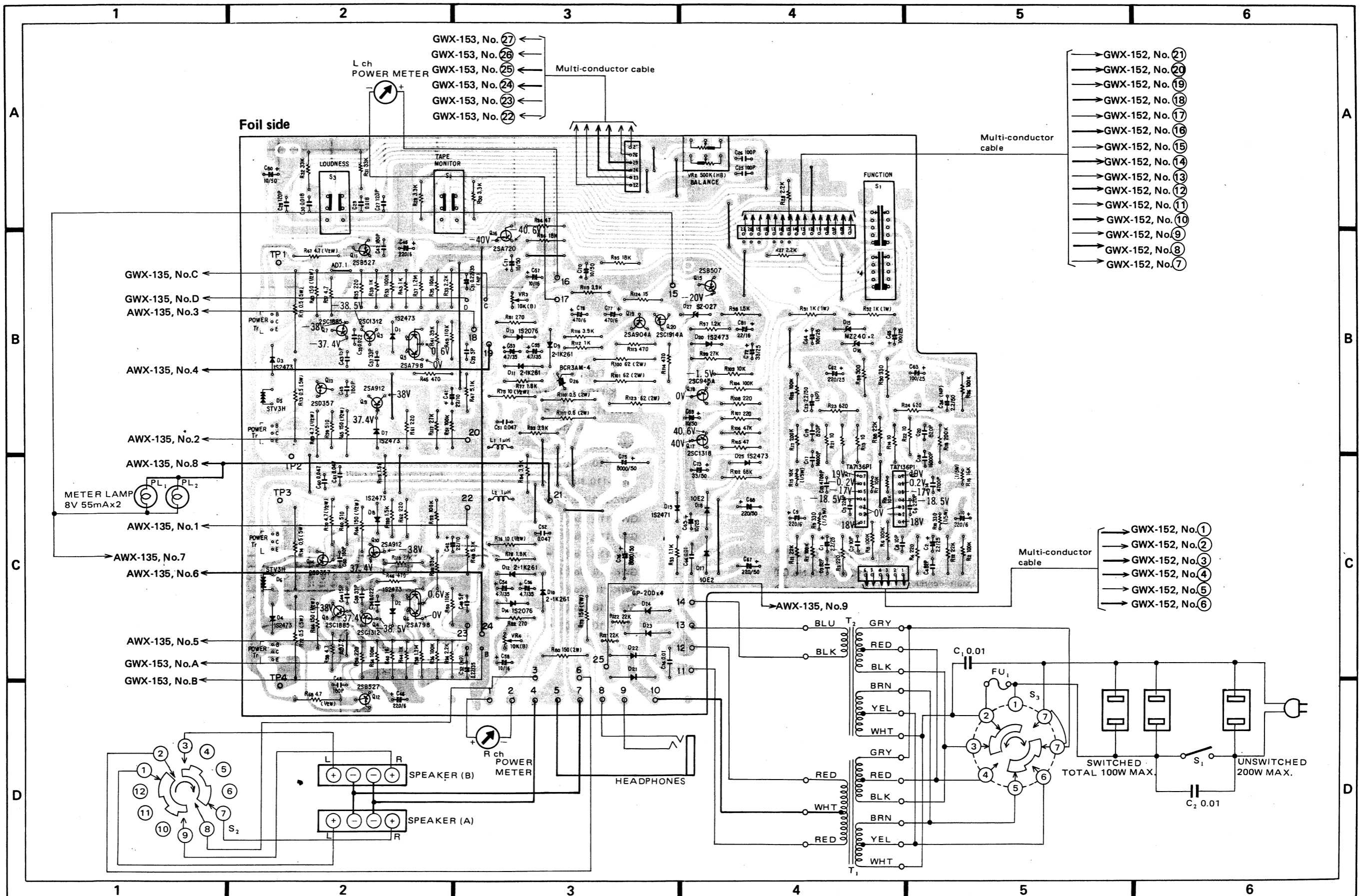

- GWX-153, No. 27
- GWX-153, No. 26
- GWX-153, No. 25
- GWX-153, No. 24
- GWX-153, No. 23
- GWX-153, No. 22

- GWX-152, No. 21
- GWX-152, No. 20
- GWX-152, No. 19
- GWX-152, No. 18
- GWX-152, No. 17
- GWX-152, No. 16
- GWX-152, No. 15
- GWX-152, No. 14
- GWX-152, No. 13
- GWX-152, No. 12
- GWX-152, No. 11
- GWX-152, No. 10
- GWX-152, No. 9
- GWX-152, No. 8
- GWX-152, No. 7

- GWX-135, No.C
- GWX-135, No.D
- AWX-135, No.3
- AWX-135, No.4
- AWX-135, No.2
- AWX-135, No.8
- AWX-135, No.1
- AWX-135, No.7
- AWX-135, No.6
- AWX-135, No.5
- GWX-153, No.A
- GWX-153, No.B

- GWX-152, No. 1
- GWX-152, No. 2
- GWX-152, No. 3
- GWX-152, No. 4
- GWX-152, No. 5
- GWX-152, No. 6

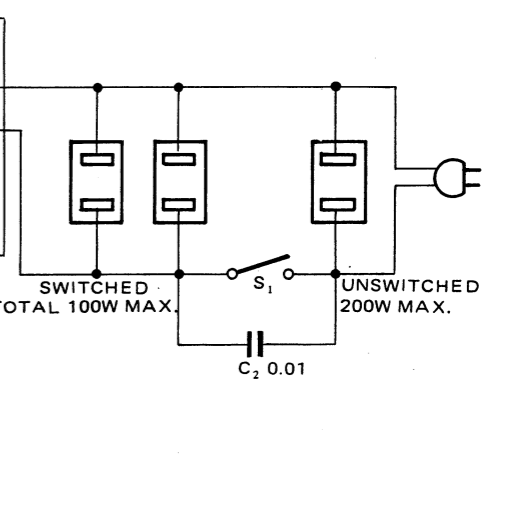
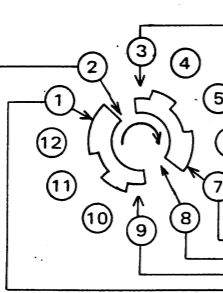

SA-606/S, S/G

Parts List of AF Assembly (GWK-110)

NOTE:
The parts of the GWK-110 is the same as the GWK-111 (KU type) except for following sections.

RESISTORS

Symbol	Part No.	Description
R93	RD4PS 112J	Carbon film 1.1k
R97	RD4PS 122J	Carbon film 1.2k
R98	RD4PS 152J	Carbon film 1.5k

3.4 VOLUME ASSEMBLY (GWX-153)

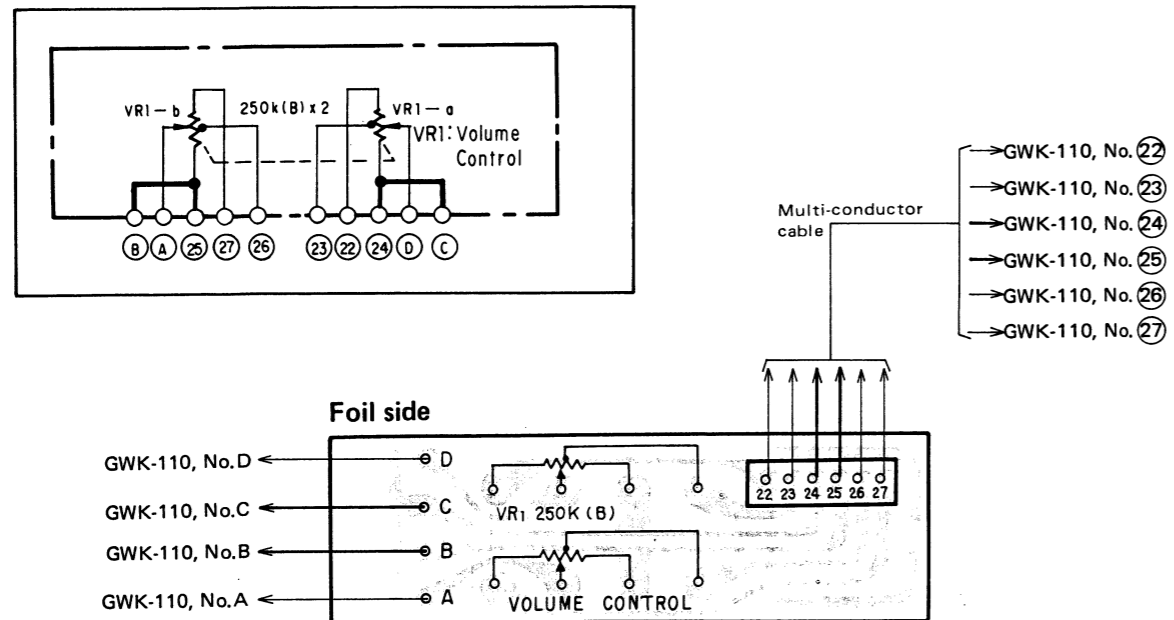

NOTE:
The parts of the GWX-153 is the same as the GWX-155 (KU type).

3.5 INPUT TERMINAL ASSEMBLY (GWX-152)

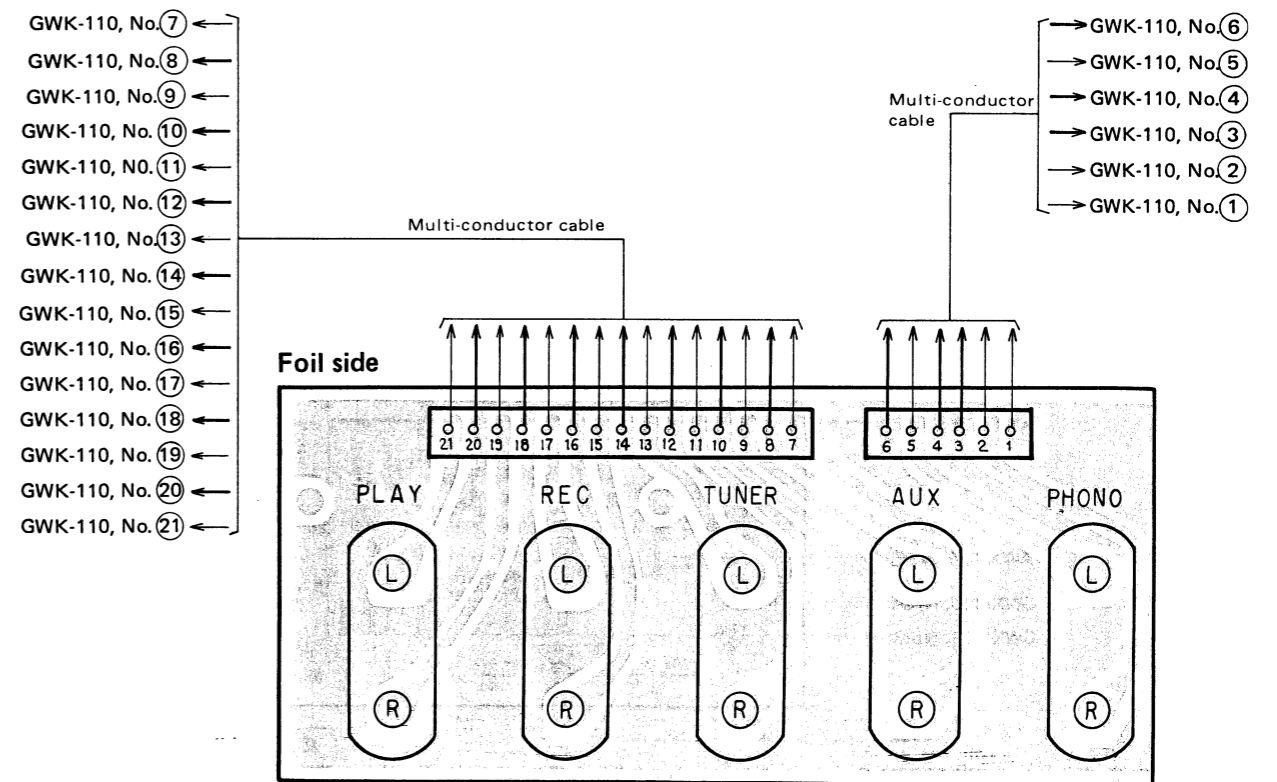
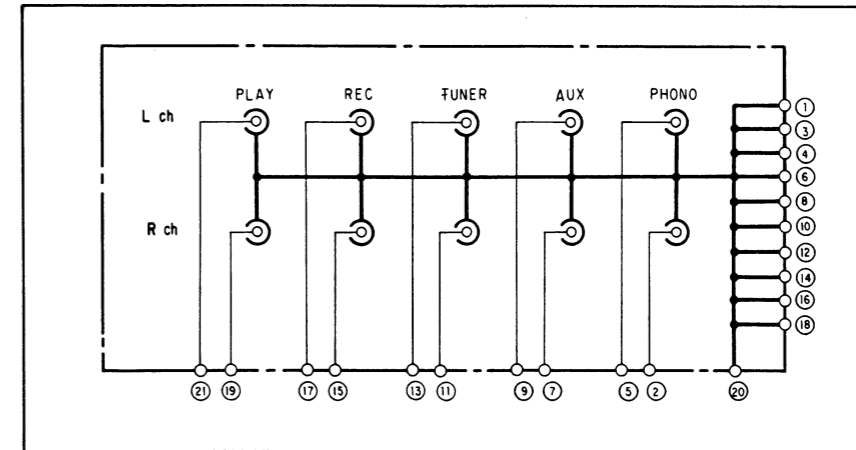

NOTE:
The parts of the GWX-152 is the same as the GWX-154 (KU type).

3.6 TONE AND INDICATOR ASSEMBLY (AWX-135)

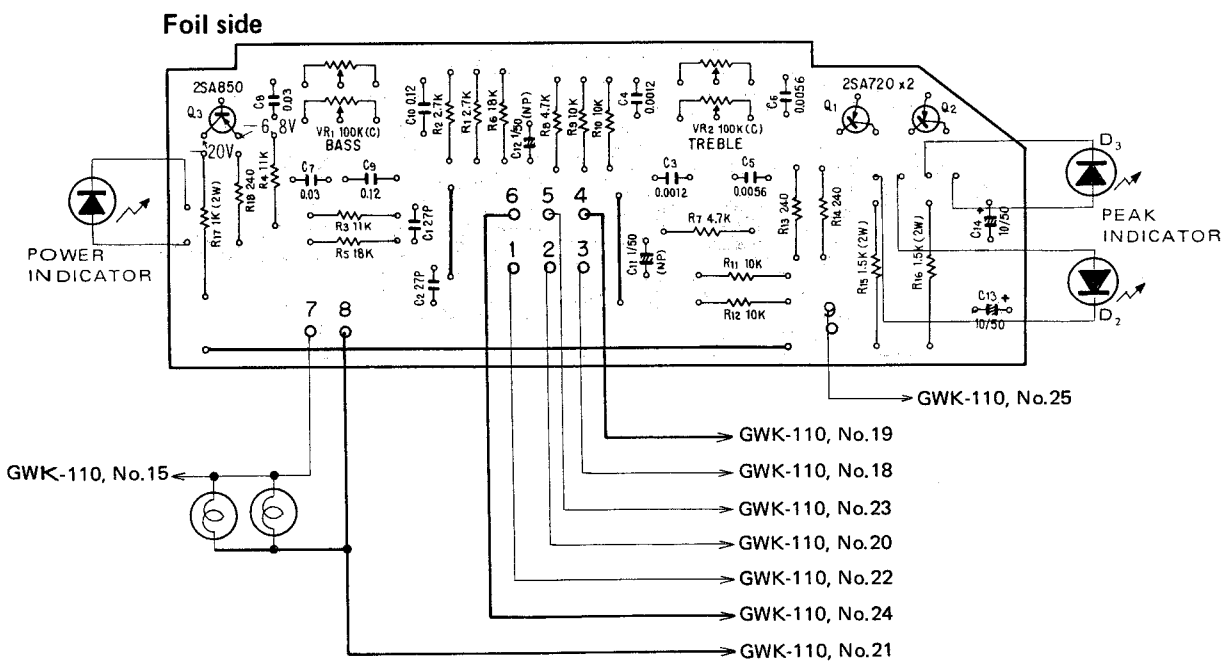
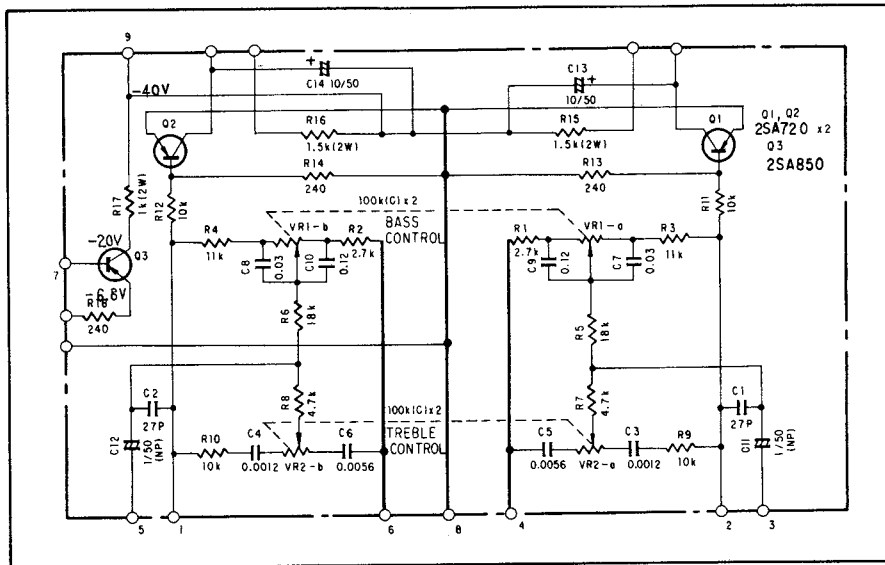

NOTE:
The parts of the AWX-135 is the same as the AWX-136 (KU type).

4. SUPPLEMENTS FOR HG TYPE

4.1 EXPLODED VIEW

NOTE:

Parts indicated in green type cannot be supplied.

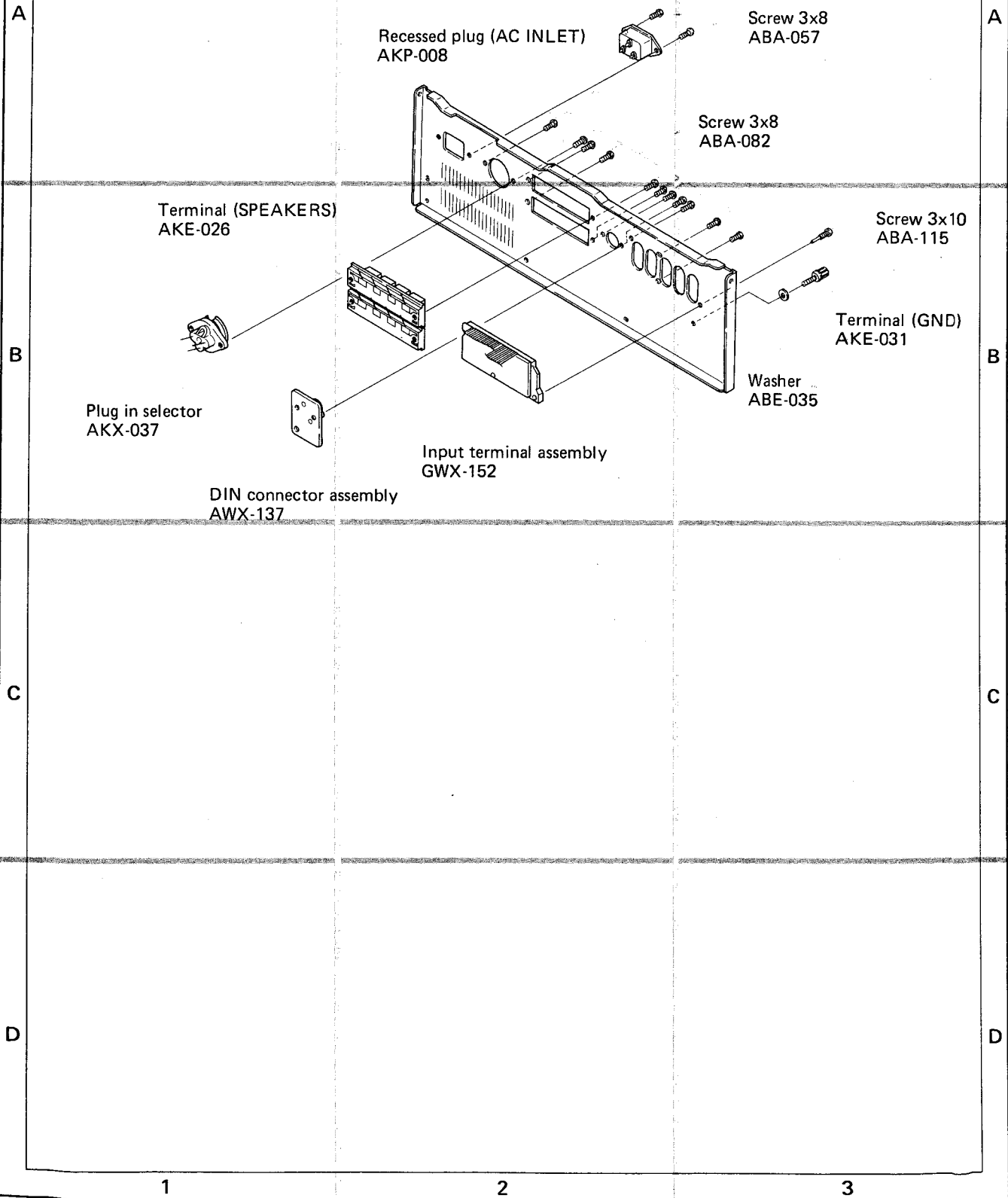

4.2 SCHEMATIC DIAGRAM

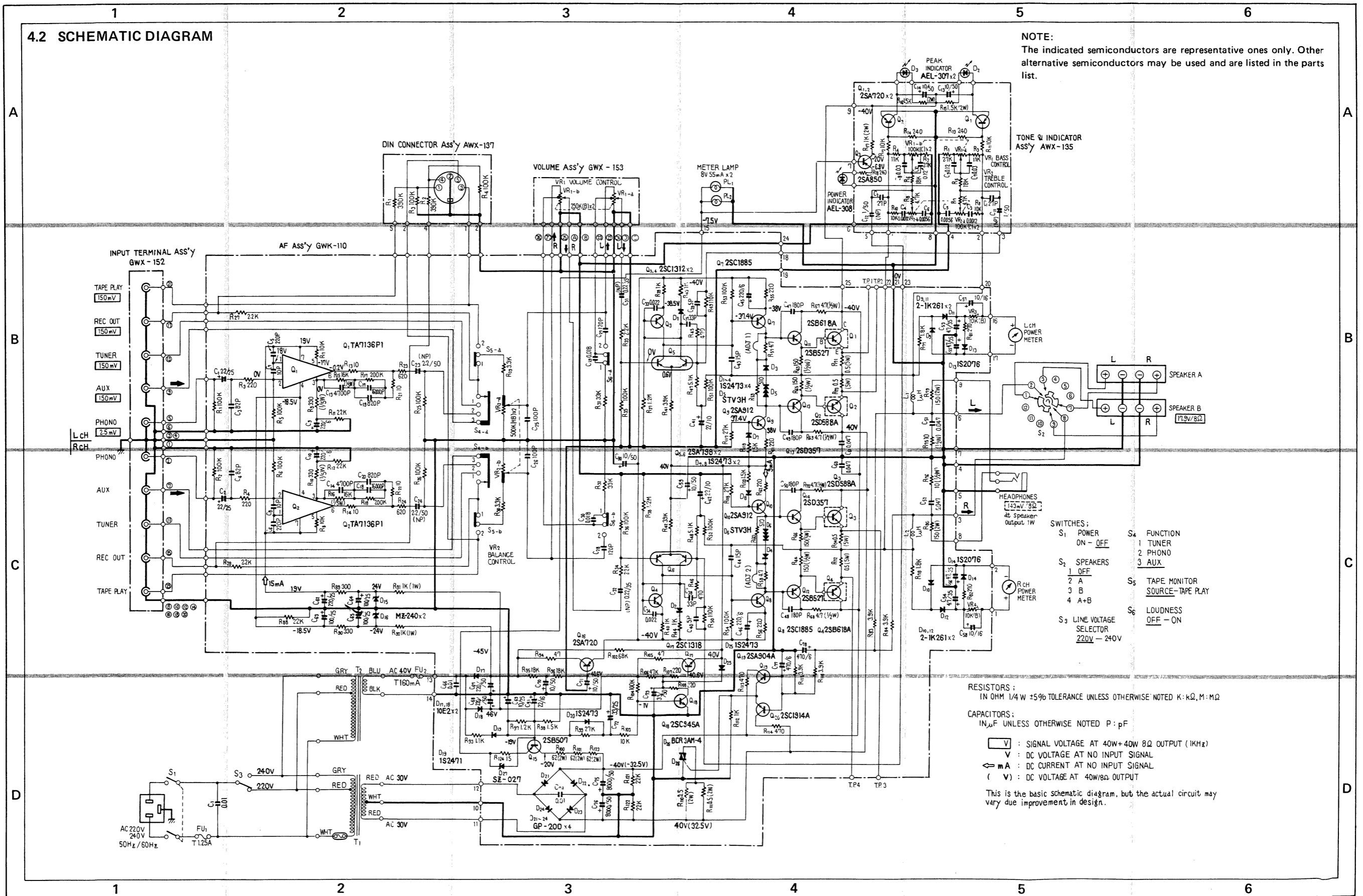

NOTE:
The indicated semiconductors are representative ones only. Other alternative semiconductors may be used and are listed in the parts list.

TONE & INDICATOR
ASS'Y AWX-135

- SWITCHES:
- S₁ POWER ON - OFF
 - S₂ SPEAKERS 1 OFF
 - S₃ TAPE MONITOR SOURCE - TAPE PLAY
 - S₄ FUNCTION 1 TUNER 2 PHONO 3 AUX
 - S₅ LOUDNESS OFF - ON

RESISTORS:
IN OHM 1/4 W ±5% TOLERANCE UNLESS OTHERWISE NOTED K: kΩ, M: MΩ

CAPACITORS:
IN μF UNLESS OTHERWISE NOTED P: pF

V : SIGNAL VOLTAGE AT 40W+40W OUTPUT (1KH_Z)
V : DC VOLTAGE AT NO INPUT SIGNAL
mA : DC CURRENT AT NO INPUT SIGNAL
V : DC VOLTAGE AT 40W/8Ω OUTPUT

This is the basic schematic diagram, but the actual circuit may vary due improvement in design.

4.3 DIN CONNECTOR ASSEMBLY (AWX-137)

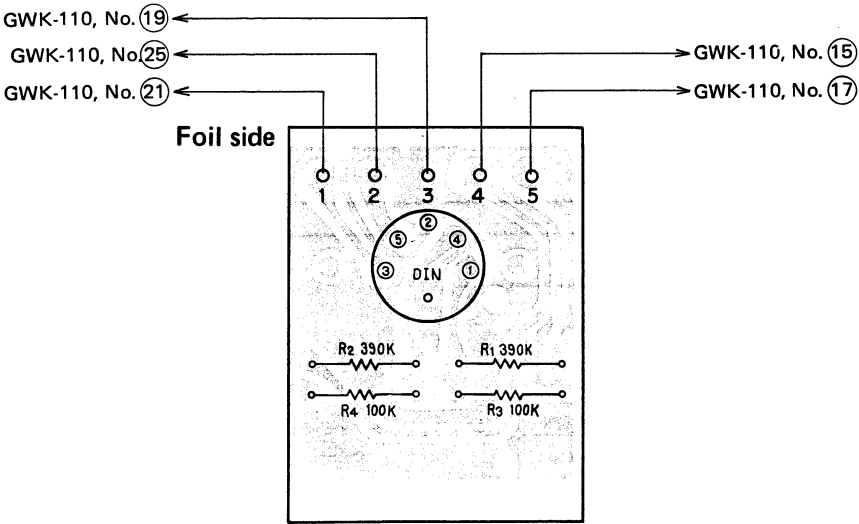
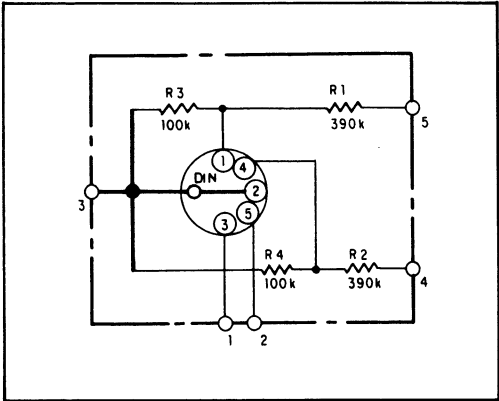

Parts List of DIN connector Assembly (AWX-137)

CONNECTOR

Symbol	Part No.	Description
	AKP-011	5P DIN socket

RESISTORS

Symbol	Part No.	Description
R1	RD¼PS 394J	Carbon film 390k
R2	RD¼PS 394J	Carbon film 390k
R3	RD¼PS 104J	Carbon film 100k
R4	RD¼PS 104J	Carbon film 100k

STEREO AMPLIFIER

SA-606

HG

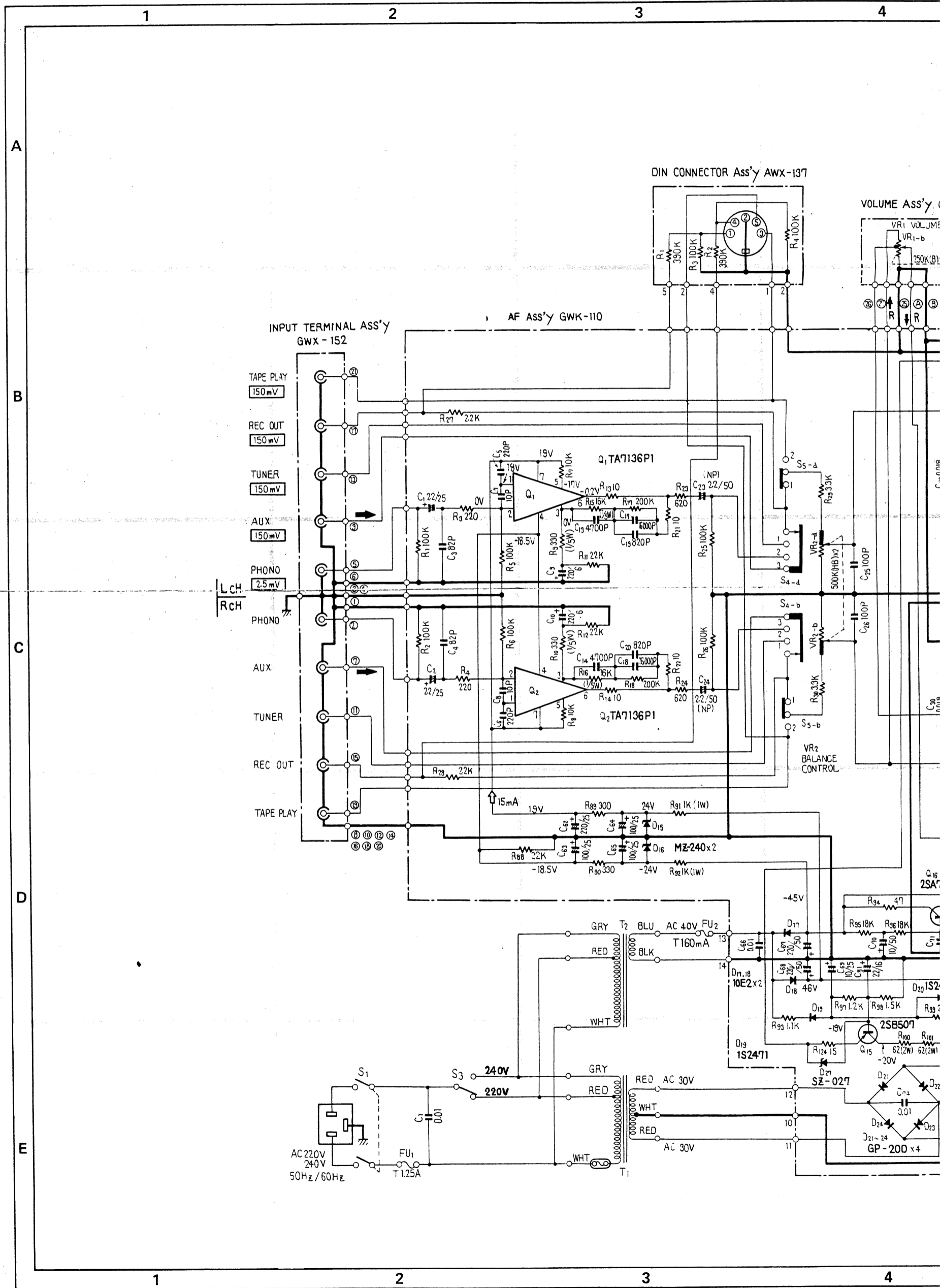

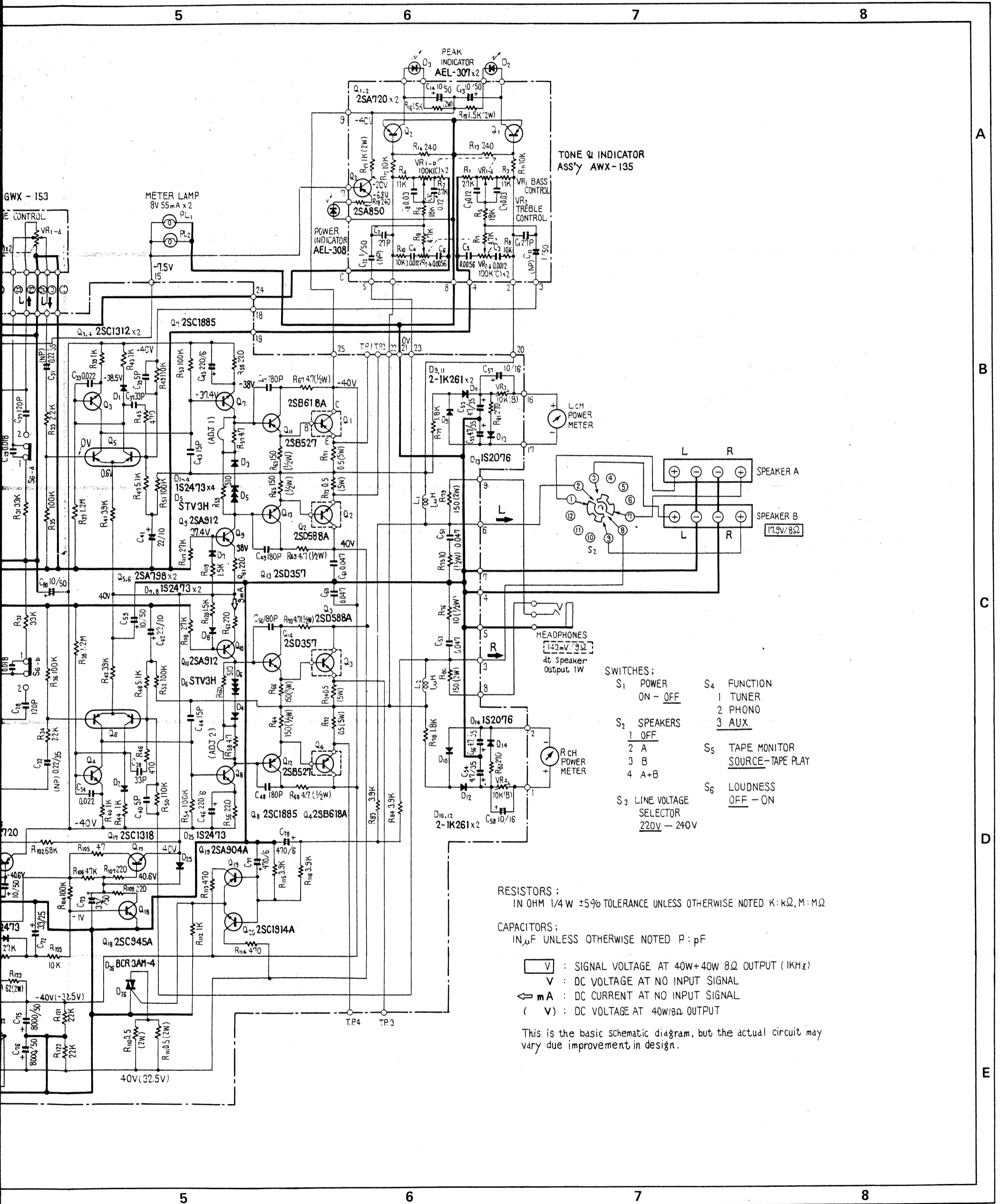

TONE & INDICATOR ASS'Y AWX-135

- SWITCHES;
- | | |
|--|--|
| S ₁ POWER ON - OFF | S ₄ FUNCTION |
| S ₂ SPEAKERS | 1 TUNER |
| 1 OFF | 2 PHONO |
| 2 A | 3 AUX |
| 3 B | S ₅ TAPE MONITOR SOURCE-TAPE PLAY |
| 4 A+B | S ₆ LOUDNESS OFF - ON |
| S ₃ LINE VOLTAGE SELECTOR 220V - 240V | |

RESISTORS;
IN OHM 1/4 W ±5% TOLERANCE UNLESS OTHERWISE NOTED K:kΩ, M:MΩ

CAPACITORS;
IN μF UNLESS OTHERWISE NOTED P:pF

- ∇ : SIGNAL VOLTAGE AT 40W+40W 8Ω OUTPUT (1KHz)
- V : DC VOLTAGE AT NO INPUT SIGNAL
- \leftarrow mA : DC CURRENT AT NO INPUT SIGNAL
- (V) : DC VOLTAGE AT 40W/8Ω OUTPUT

This is the basic schematic diagram, but the actual circuit may vary due to improvement in design.

STEREO AMPLIFIER

SA-606

S
S/G

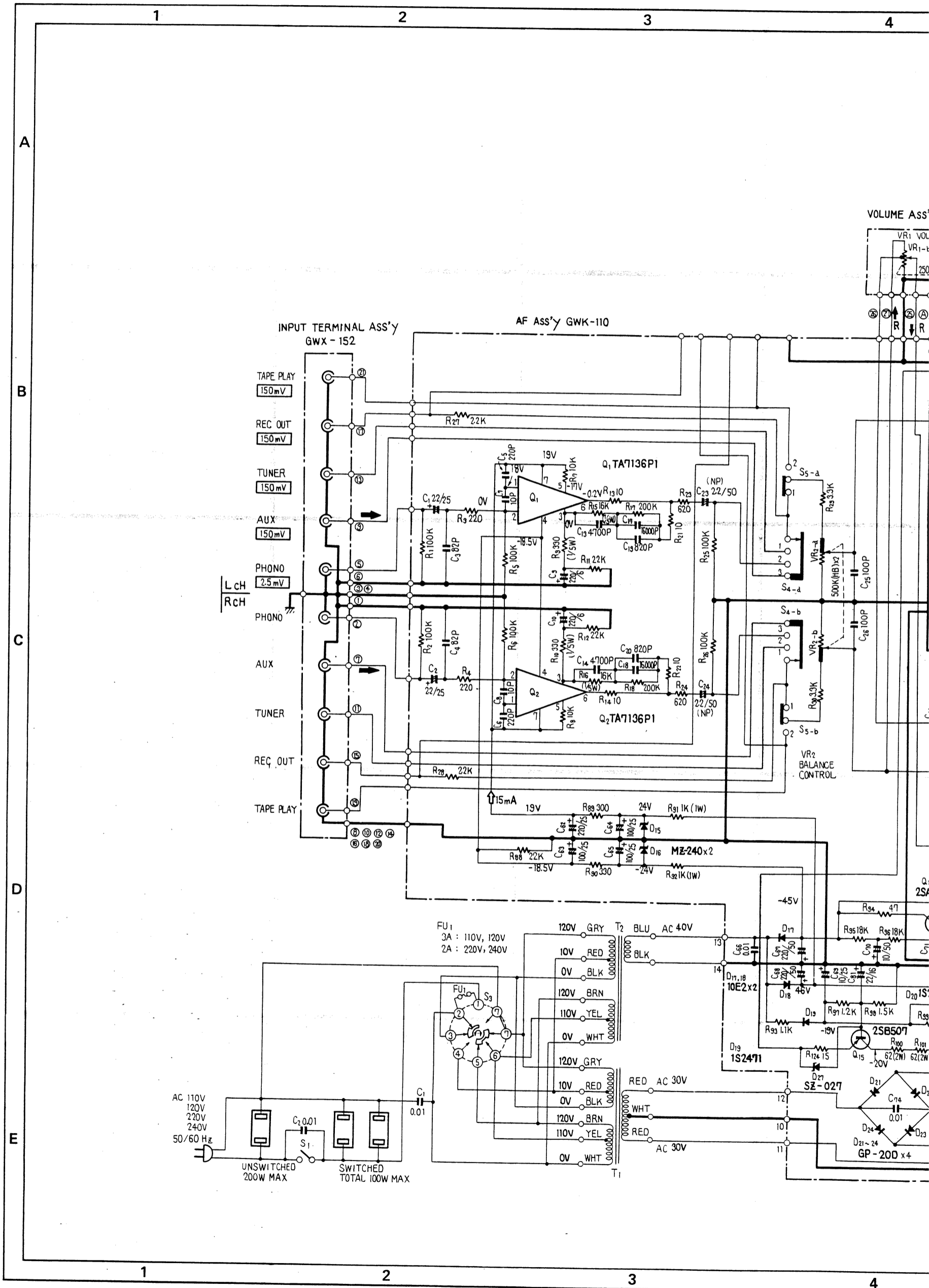

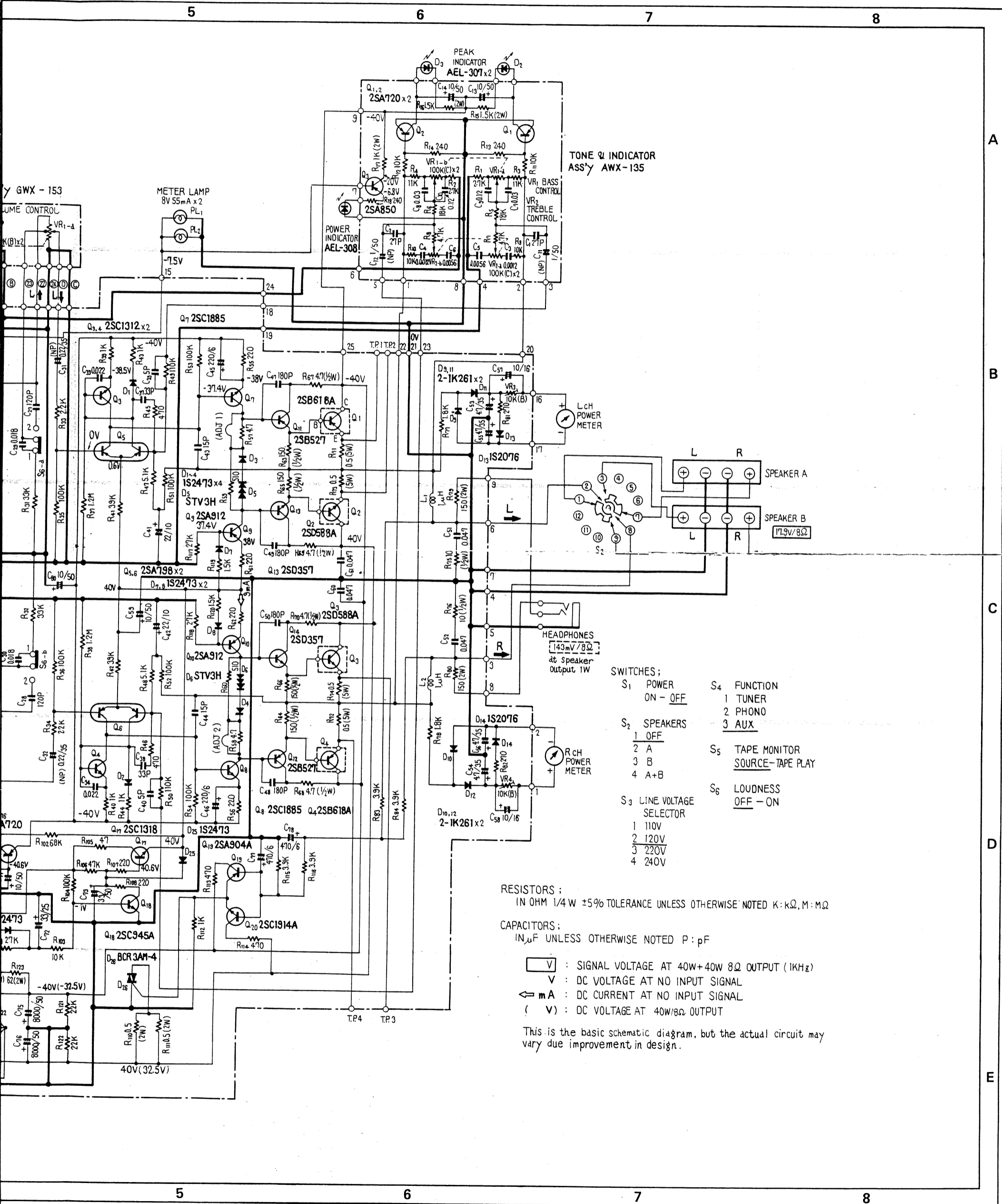

STEREO AMPLIFIER

SA-6700

KU
KC

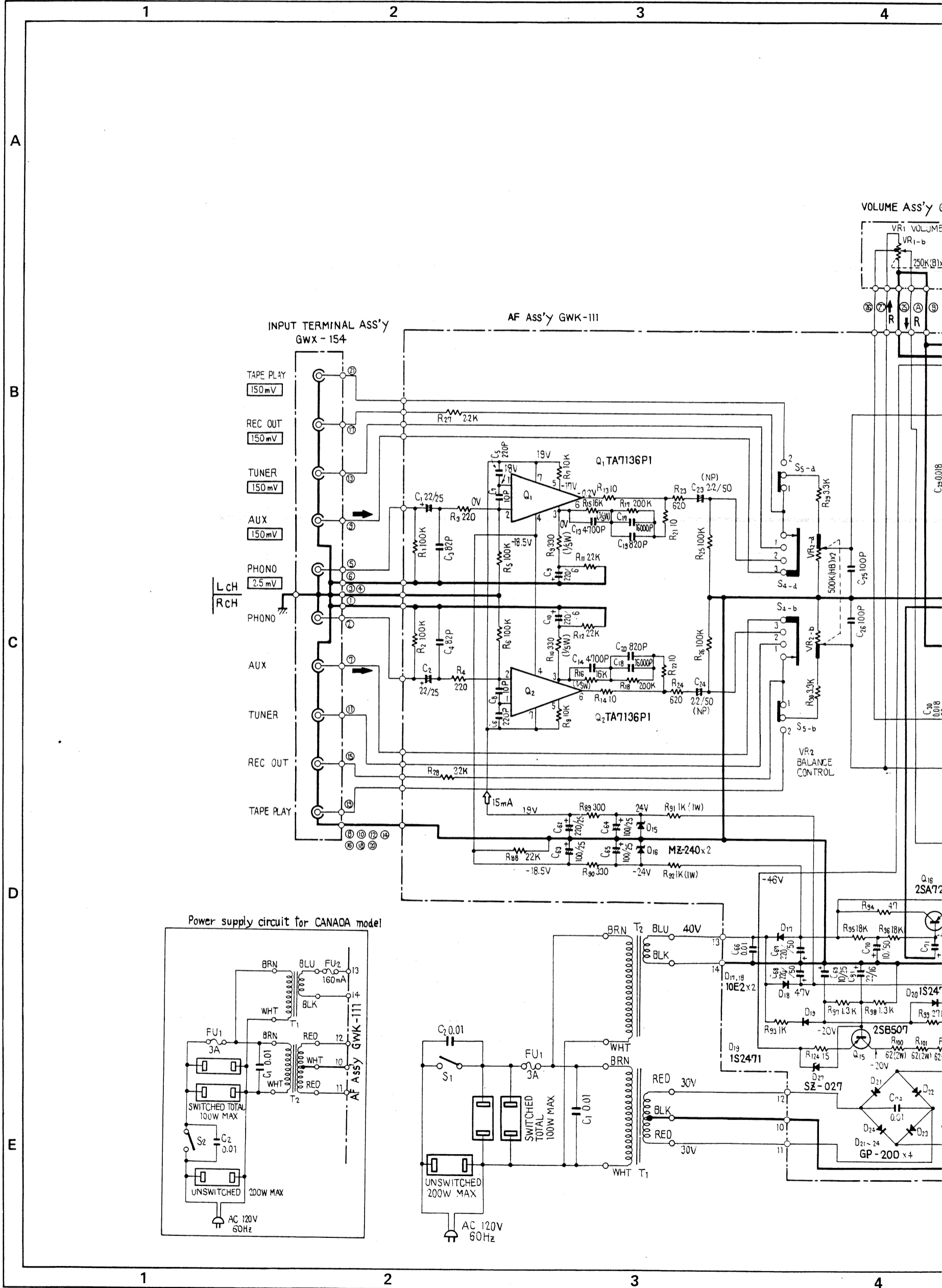

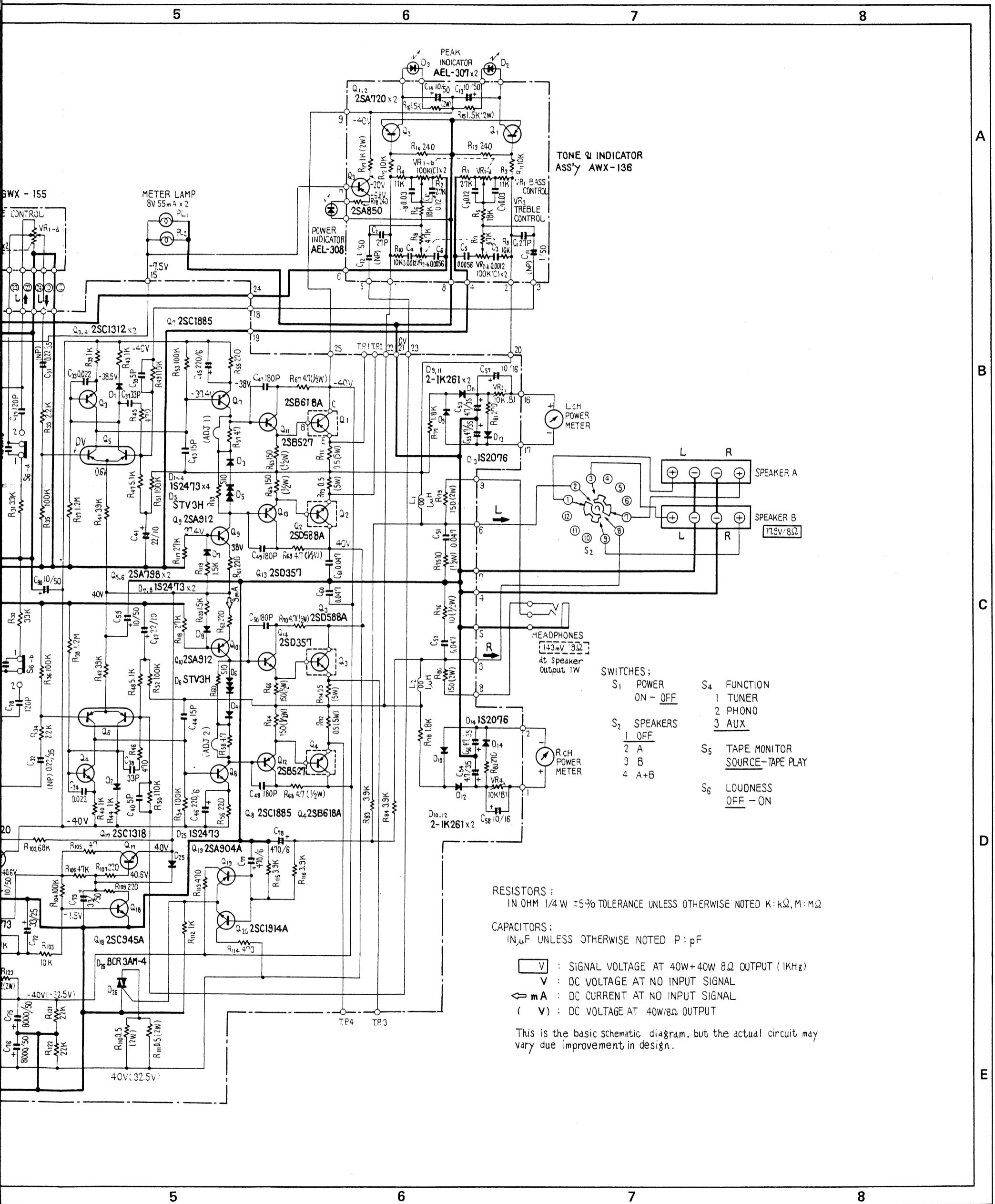

- SWITCHES:
- S₁ POWER ON - OFF
 - S₂ SPEAKERS
 - 1 OFF
 - 2 A
 - 3 B
 - 4 A+B
 - S₄ FUNCTION
 - 1 TUNER
 - 2 PHONO
 - 3 AUX
 - S₅ TAPE MONITOR SOURCE-TAPE PLAY
 - S₆ LOUDNESS OFF - ON

RESISTORS:
IN OHM 1/4W ±5% TOLERANCE UNLESS OTHERWISE NOTED K: kΩ, M: MΩ

CAPACITORS:
IN μF UNLESS OTHERWISE NOTED P: pF

- \square V : SIGNAL VOLTAGE AT 40W+40W 8Ω OUTPUT (1KHz)
- V : DC VOLTAGE AT NO INPUT SIGNAL
- ← mA : DC CURRENT AT NO INPUT SIGNAL
- (V) : DC VOLTAGE AT 40W/8Ω OUTPUT

This is the basic schematic diagram, but the actual circuit may vary due to improvement in design.