

★ SAFETY INSTRUCTIONS

PRECAUTIONS DURING SERVICING

- Parts identified by the (*) symbol are critical for safety. Replace only with parts number specified.
- In addition to safety, other parts and assemblies are specified for conformance with such regulations as those applying to spurious radiation.
These must also be replaced only with specified replacements.
Examples: RF converters, tuner units, antenna selector switches, RF cables, noise blocking capacitors, noise blocking filters, etc.
- Use specified internal wiring. Note especially:
 - Wires covered with PVC tubing
 - Double insulated wires
 - High voltage leads
- Use specified insulating materials for hazardous live parts. Note especially:
 - Insulation Tape
 - PVC tubing
 - Spacers (Insulating Barriers)
 - Insulation sheets for transistors
 - Plastic screws for fixing microswitch (especially in turntable)
- When replacing AC primary side components (transformers, power cords, Noise blocking capacitors, etc.), wrap ends of wires securely about the terminals before soldering.

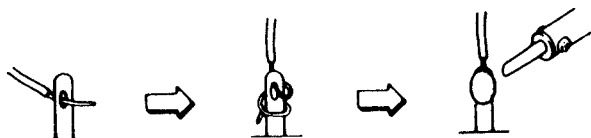

- Observe that wires do not contact heat producing parts (heatsinks, oxide metal film resistors, fusible resistors, etc.).
- Check that replaced wires do not contact sharp edged or pointed parts.
- Also check areas surrounding repaired locations.
- Use care that foreign objects (screws, solder, droplets, etc.) do not remain inside the set.

SAFETY CHECK AFTER SERVICING

After servicing, make measurements of leakage-current or resistance in order to determine that exposed parts are acceptably insulated from the supply circuit.

The leakage-current measurement should be done between accessible metal parts (such as chassis, ground terminal, microphone jacks, signal-input/output connectors, etc.) and the earthground through a resistor of 1500 ohms paralleled with a 0.15 μ F capacitor, under the unit's normal working conditions. The leakage-current should be less than 0.5 mA rmsAC.

The resistance measurement should be done between accessible exposed metal parts and power cord plug prongs with the power switch (if included) "ON". The resistance should be more than 2.2 Mohms.

PRECAUTIONS FOR LITHIUM BATTERY

The lithium battery may explode when heated excessively. [OBSERVE THE FOLLOWING WHEN REPLACING]

- Replace with the same make and type only.
- Use soldering iron in "recommended way" only.
- Place battery in correct polarity.
- Do not short the terminals.
- Do not charge battery.
- Do not dispose of battery in fire.

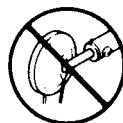

[DANGER]



[RECOMMENDED WAY]

MAKE YOUR CONTRIBUTION TO PROTECT THE ENVIRONMENT

Used batteries with the ISO symbol for recycling as well as accumulators (rechargeable batteries), mini-batteries (cells) and starter batteries should not be thrown into the garbage can.



Please leave them at an appropriate depot. All other household batteries can be thrown out with the household waste.

★ INFORMATION

SYMBOLS FOR PRIMARY DESTINATION

Alphabet indicates the destination of the units as listed below.

Symbols	Principal Destinations
B	UK
E	Europe (except UK)
S	Australia
V	Germany
U	Universal Area
Y*	Custom version

I. DISASSEMBLY

In case of trouble, etc. necessitating dismantling, please dismantle in the order shown in the illustrations. Reassemble in reverse order.

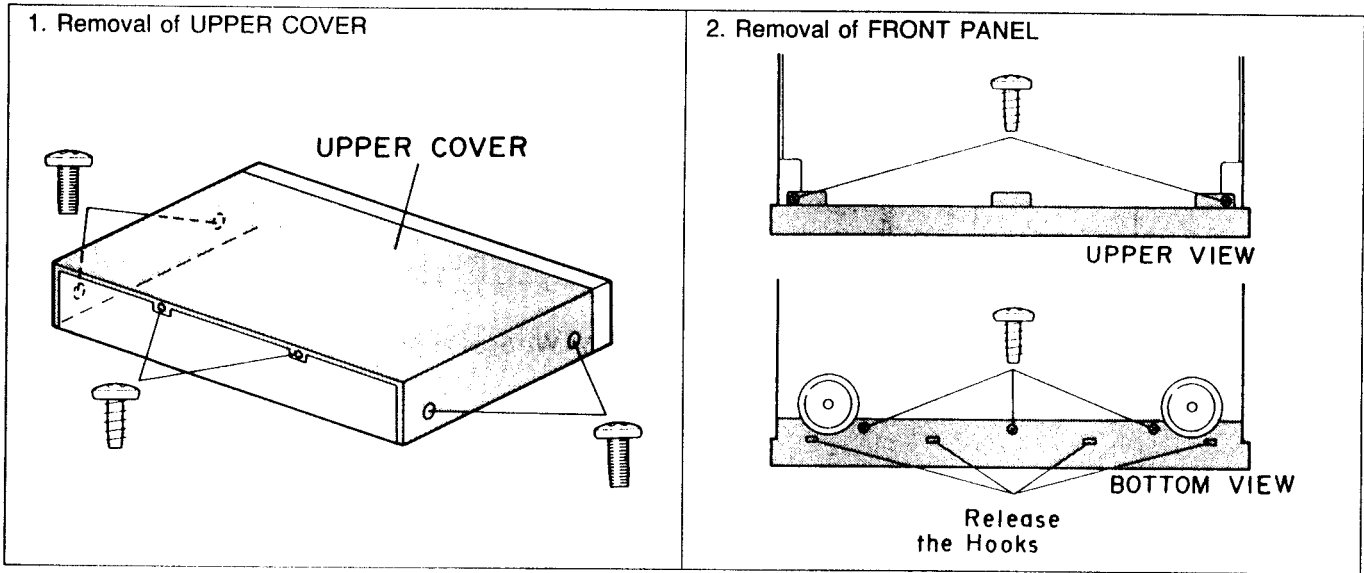

II. PRINCIPAL PARTS LOCATION

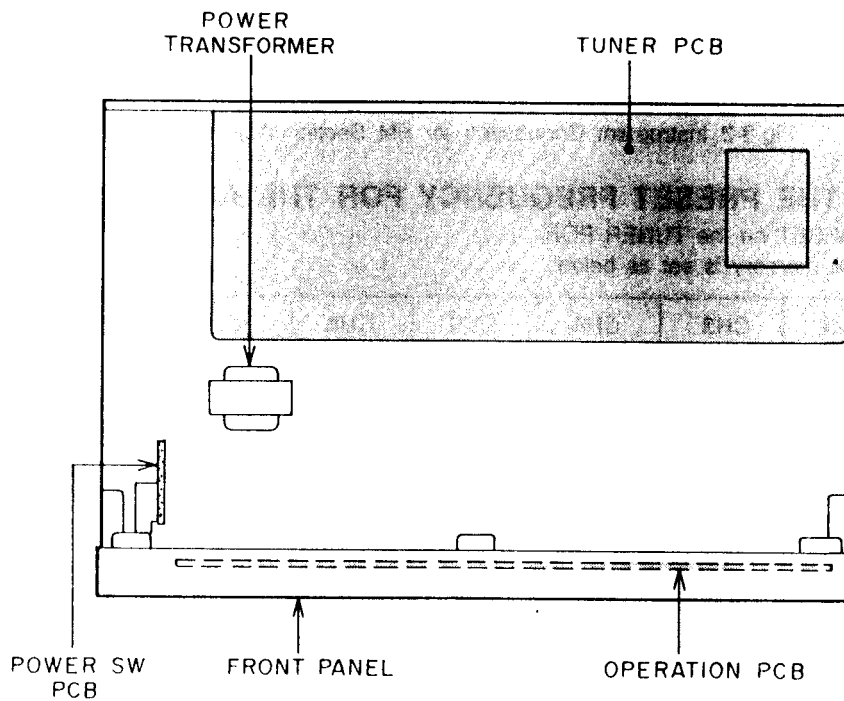

Fig.2-1 Top view

III. ADJUSTMENT

3-1. INSTRUMENT CONNECTIONS

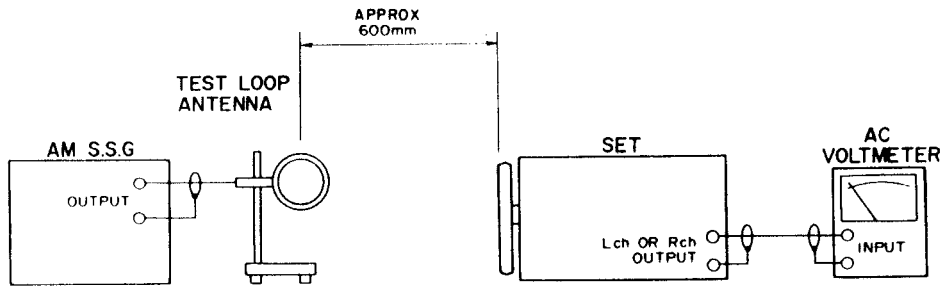

Fig.3-1 Instrument Connection for AM (MW,LW) Section Adjustment

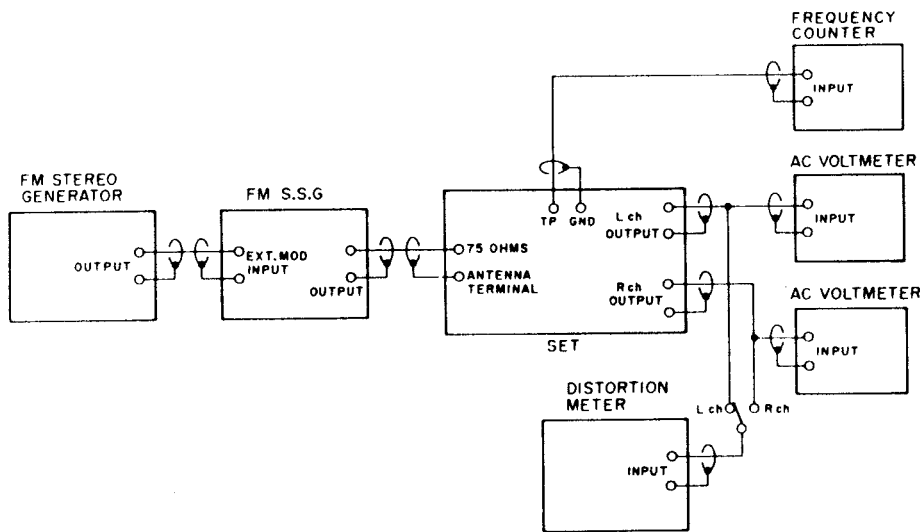

Fig.3-2 Instrument Connection for FM Section Adjustment

3-2. HOW TO CALL THE PRESET FREQUENCY FOR THE ADJUSTMENT

Short the TEST POINT of RESET on the TUNER PCB.

The internal frequency preset memory is set as below.

	CH1	CH2	CH3	CH4	CH5	CH6	CH7	CH8	CH9	CH10
AT-57 9 kHz/ V	FM 87.5MHz	FM 88.0MHz	FM 90.0MHz	FM 94.0MHz	FM 96.0MHz	FM 98.0MHz	FM 100.0MHz	FM 102.0MHz	FM 106.0MHz	FM 108.0MHz
AT-57L 9 kHz/E,B	FM 87.5MHz	FM 88.0MHz	FM 90.0MHz	FM 94.0MHz	FM 96.0MHz	FM 98.0MHz	FM 100.0MHz	FM 102.0MHz	FM 106.0MHz	FM 108.0MHz

CH11	CH12	CH13	CH14	CH15	CH16	CH17	CH18	CH19	CH20
AM 531kHz	AM 531kHz	AM 603kHz	AM 603kHz	AM 999kHz	AM 999kHz	AM 1404kHz	AM 1404kHz	AM 1602kHz	AM 1602kHz
MW 531kHz	MW 531kHz	MW 603kHz	MW 603kHz	MW 999kHz	MW 999kHz	MW 1404kHz	MW 1404kHz	MW 1602kHz	MW 1602kHz

CH21	CH22	CH23	CH24	CH25	CH26	CH27	CH28	CH29	CH30
FM 87.5MHz	FM 88.0MHz	FM 90.0MHz	FM 94.0MHz	FM 96.0MHz	FM 98.0MHz	FM 100.0MHz	FM 102.0MHz	FM 106.0MHz	FM 108.0MHz
LW 144kHz	LW 144kHz	LW 162kHz	LW 162kHz	LW 198kHz	LW 198kHz	LW 297kHz	LW 297kHz	LW 351kHz	LW 351kHz

IV. PARTS LIST

ATTENTION

1. When placing orders, please refer to this Parts List for correct part numbers. Otherwise, the correct delivery of parts cannot be guaranteed.

2. Please make sure that Part No. is correct when ordering. If not, a part different from the one you ordered may be delivered.

3. Since the parts shown in Parts List of Preliminary Service Manual may have been the subject of changes, please use this Parts List for all future reference.

HOW TO USE THIS PARTS LIST

- This Parts List lists those parts which are considered necessary for repairs. Other common parts, such as resistors and capacitors, are listed in the "Common List for Service Parts" from which these parts should be selected and stocked.
- The Recommended Spare Parts List shows those parts in the Parts List which are considered particularly important for service.
- Parts not shown in the Parts List and "Common List for Service Parts" will not in principle be supplied.
- How to read the Parts List.

a) Mechanism Block

2. HEAD BASE BLOCK

Ref. No.	Part No.	Description
1	BH-T2023A320A	HEAD BASE BLOCK
2	HP-H2206A010A	HEAD R/P PR4-BFU C
3	ZS-477876	PAN20x03STL CMT
4	ZS-536488	BID20x08STL CMT
5	ZG-402895	SP CS ANGLE ADJUST

SP (Service Parts) Classification

This number corresponds with the individual parts index number in that figure.

b) PC Board

6. MAIN PC BOARD

Ref. No.	Part No.	Description
IC1	EI-324536	IC HD14049BP
IC2	EI-336801	IC MB8841-564M
C1A	EC-338399	C MMY V 223M 250AC [U,E,B,S]
C1B	EC-350949	C MMY V 223M 250DC [J]
C1C	EC-338397	C MMY V 223M 125AC [C,A]
X1	EI-318384	OSC XTAL NC-18C

Symbols for primary destination

- [A]: AAL (U.S.A) [S]: SAA (Australia)
- [B]: BEAB (England) [U]: U/T (Universal Area)
- [C]: CSA (Canada)
- [E]: CEE (Europe) [V]: VDE (Germany)
- [J]: JPN (Japan) [Y]: Custom Version

SP (Service Parts) Classification

These reference symbols correspond with component symbols in the Schematic Diagrams.

The available PC Board Blocks are listed separately.

- When Part No. is known, Parts Index at end of Parts List can be used to locate where that part is shown in Parts List by its Reference No. listed at right of Part No.

WARNING

(*) INDICATES SAFETY CRITICAL COMPONENTS. FOR CONTINUED SAFETY, REPLACE SAFETY CRITICAL COMPONENTS ONLY WITH MANUFACTURER'S RECOMMENDED PARTS.

AVERTISSEMENT

(*) IL INDIQUE LES COMPOSANTS CRITIQUES DE SÉCURITÉ. POUR MAINTENIR LE DEGRÉ DE SÉCURITÉ DE L'APPAREIL, NE REMPLACER QUE DES PIÈCES RECOMMANDÉES PAR LE FABRICANT.

1. RECOMMENDED SPARE PARTS

We suggest you to stock the following Recommended Spare Part items listed below since they can cover most of the routine service.

Ref.No.	Part No.	Description
1	*BT-729938J	TRANS POW AT-56 (B)
2	*BT-729935J	TRANS POW AT-56 (E,V)
3	ED-360236	D LED GL-5EG8 GREEN
4	ED-360318	D SILICON H MA700
5	ED-307572	D SILICON H 1SS131
6	ED-729939J	D SILICON H 1SS135T-72
7	*ED-729940J	D SILICON 1A2-E
8	ED-349460-A	D VARACTOR SVC321SPA ABCD DBL
9	ED-384516J	D ZENER H 05AZ24-R
10	ED-384567J	D ZENER H 05AZ6.8-V
11	EE-732796J	FRONT END FM-FTZ AT-57
12	*EF-365246	FUSE BET T 250V 125MA
13	*EF-358974	FUSE BET T 250V 630MA
14	EH-344434	FILTER CE 3FC450C4N 0.450MHZ
15	EH-338338	FILTER CE 3FE10.7MS3GK-A
16	EH-729952J	FILTER CE 10T
17	EH-729945J	FILTER LP
18	EI-715106	IC BA6154
19	EI-723340J	IC LA1266A
20	EI-729961J	IC LA3401
21	EI-361622	IC LM7001
22	*EI-728465K	IC MC7805AC
23	*EI-386309J	IC NJM7812A
24	EI-704824	IC TA7060AP
25	EI-732797J	IC TMP47C410N 1394
26	EI-349970	OSC CE CSB456F11 0.456MHZ
27	CI-382875J	OSC CE CST400MGW 4MHZ
28	EI-344422	OSC XTAL HC-18.1U 7.200MHZ
29	EM-390703J	IND FL FV361 CHARACTER
30	*ER-328278	R FUSE H ERD2FC 1.4W 10R0G
31	*ER-303840	R OMF H FS 1W 470J
32	*ER-341331	R OMF H S15 FS 1W 181J
33	*ES-729964J	SW PUSH (POWER SW)
34	ES-729963J	SW TACT 01C1PE (ANT A/B)
35	ET-390397J	DETECTOR GP1U501
36	ET-370310	TR DTC144TS
37	ET-353734	TR FET 2SJ103 GR,BL
38	ET-363326	TR FET 2SK161 GR
39	ET-359827	TR FET 2SK246 BL
40	ET-389803J	TR 2SA933S R,S
41	ET-400218J	TR 2SC1740S R,S
42	ET-702699	TR 2SC1923 R
43	ET-338565	TR 2SD1302 R,S
44	EZ-729962J	BATTERY CR2032THA

2. P.C BOARD

Ref.No.	Part No.	Description
1	BA-732794J	PC (#) TUNER BLK AT-57 (V) [V]
2	BA-732795J	PC (#) TUNER BLK AT-57L (E) [E,B]

PC (#) TUNER BLK CONSISTS OF FOLLOWING P.C BOARD.

- TUNER P.C BOARD
- CONTROL P.C BOARD
- POWER SW P.C BOARD

3. TUNER P.C BOARD

Ref.No.	Part No.	Description
C201	EC-729958J	C S-FIX 10P
C210	EC-729959J	C S-FIX 30P [AT-57L]
D001	ED-729939J	D SILICON H 1SS135T-72
D002	ED-729939J	D SILICON H 1SS135T-72
D003	ED-729939J	D SILICON H 1SS135T-72
D004	ED-729939J	D SILICON H 1SS135T-72
D005	ED-729939J	D SILICON H 1SS135T-72
D006	ED-729939J	D SILICON H 1SS135T-72
D101	ED-307572	D SILICON H 1SS131
D102	ED-307572	D SILICON H 1SS131
D103	ED-307572	D SILICON H 1SS131
D104	ED-307572	D SILICON H 1SS131
D105	ED-307572	D SILICON H 1SS131
D106	ED-360318	D SILICON H MA700
D107	ED-360318	D SILICON H MA700
D108	ED-307572	D SILICON H 1SS131
D109	ED-307572	D SILICON H 1SS131
D110	ED-307572	D SILICON H 1SS131
D111	ED-307572	D SILICON H 1SS131
D112	ED-307572	D SILICON H 1SS131
D201	ED-349460-A	D VARACTOR SVC321SPA ABCD DBL
D202	ED-349460-A	D VARACTOR SVC321SPA ABCD DBL
D203	ED-349460-A	D VARACTOR SVC321SPA ABCD DBL [AT-57L]
D204	ED-349460-A	D VARACTOR SVC321SPA ABCD DBL [AT-57L]
D205	ED-307572	D SILICON H 1SS131
D301	ED-307572	D SILICON H 1SS131
D302	ED-307572	D SILICON H 1SS131
D303	ED-307572	D SILICON H 1SS131
D304	ED-307572	D SILICON H 1SS131
D305	ED-307572	D SILICON H 1SS131
D306	ED-307572	D SILICON H 1SS131
D430	ED-307572	D SILICON H 1SS131 [AT-57L]
D431	ED-307572	D SILICON H 1SS131 [AT-57L]
D432	ED-307572	D SILICON H 1SS131 [AT-57L]
D901	*ED-729940J	D SILICON 1A2-E
D902	*ED-729940J	D SILICON 1A2-E
D903	*ED-729940J	D SILICON 1A2-E
D904	*ED-729940J	D SILICON 1A2-E
D905	*ED-729940J	D SILICON 1A2-E
D906	*ED-729940J	D SILICON 1A2-E
D907	ED-384516J	D ZENER H 05AZ24-R
D908	ED-384567J	D ZENER H 05AZ6.8-V
D909	ED-307572	D SILICON H 1SS131
D912	ED-307572	D SILICON H 1SS131
D913	ED-307572	D SILICON H 1SS131
D914	ED-307572	D SILICON H 1SS131
D915	ED-729940J	D SILICON 1A2-E
D916	ED-307572	D SILICON H 1SS131
F901	*EF-358974	FUSE BET T 250V 630MA
F902	*EF-358974	FUSE BET T 250V 630MA
F903	*EF-365246	FUSE BET T 250V 125MA
J001	EJ-729941J	ANT TERMINAL 1P [FM ANT A]
J002	EJ-729942J	ANT TERMINAL [FM ANT B]
J301	EJ-729943J	PIN J US2P [OUTPUT]
L201	EO-729954J	COIL ANT MW
L202	EO-729955J	COIL ANT LW [AT-57L]
L203	EO-729956J	COIL RT72-5503
L204	EO-729957J	COIL RT72-5504 [AT-57L]
Q001	ET-389803J	TR 2SA933S R,S
Q002	ET-400218J	TR 2SC1740S R,S
Q003	ET-370310	TR DTC144TS
Q101	EI-704824	IC TA7060AP
Q102	EI-704824	IC TA7060AP
Q103	EI-702699	TR 2SC1923 R
Q104	EI-723340J	IC LA1266A
Q105	EI-389803J	TR 2SA933S R,S
Q106	ET-400218J	TR 2SC1740S R,S
Q107	ET-370310	TR DTC144TS
Q108	EI-704824	IC TA7060AP

3-3. ADJUSTMENT

STEP	ADJUSTMENT
1.	SSG frequency, output level
2.	Tuning frequency
3.	Test point / Adjustment part
4.	(●) Instrument connection (*) Result

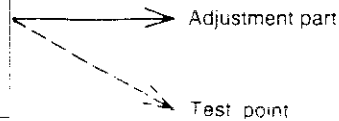

FM

NOTE: Set the S.S.G. to 1 KHz, 75 kHz deviation for E or B model, 1 kHz 40 kHz deviation for V model.

2. FM DISTORTION (IF ADJ)

- 98.0 MHz, 60 dBμ
- 98.0 MHz (IF BAND-WIDE, FM AUTO OFF)
- OUT PUT / T103
- Connect the distortion meter to the OUT PUT
* Minimum distortion.

4. FM STEREO SEPARATION (WIDE/NARROW)

- 98.0 MHz, 60 dBμ (L or R channel only)
- 98.0 MHz (IF BAND-WIDE and NARROW, FM AUTO- ON)
- OUT PUT (R or L) / R334 (WIDE), R310 (NARROW)
- Connect an AC milli-voltmeter to the OUT PUT.
(Opposite channel of signal input channel)
* Minimum output level

1. FM CENTER VOLTAGE (IF ADJ)

- 98.0 MHz, 60 dBμ
- 98.0 MHz, (IF BAND- WIDE, FM AUTO- OFF)
- TP-2 / T102
- Connect the DC voltmeter to the TP-2.
* 0 V

3. FM SIGNAL INDICATOR (WIDE/NARROW)

- 98.0 MHz, 50 dBμ (Stereo)
- 98.0 MHz (IF BAND- WIDE and NARROW)
- SIGNAL indicator on the FRONT PANEL / R132 (WIDE), R131 (NARROW)
- * 5 th LED light up on signal strength indicator

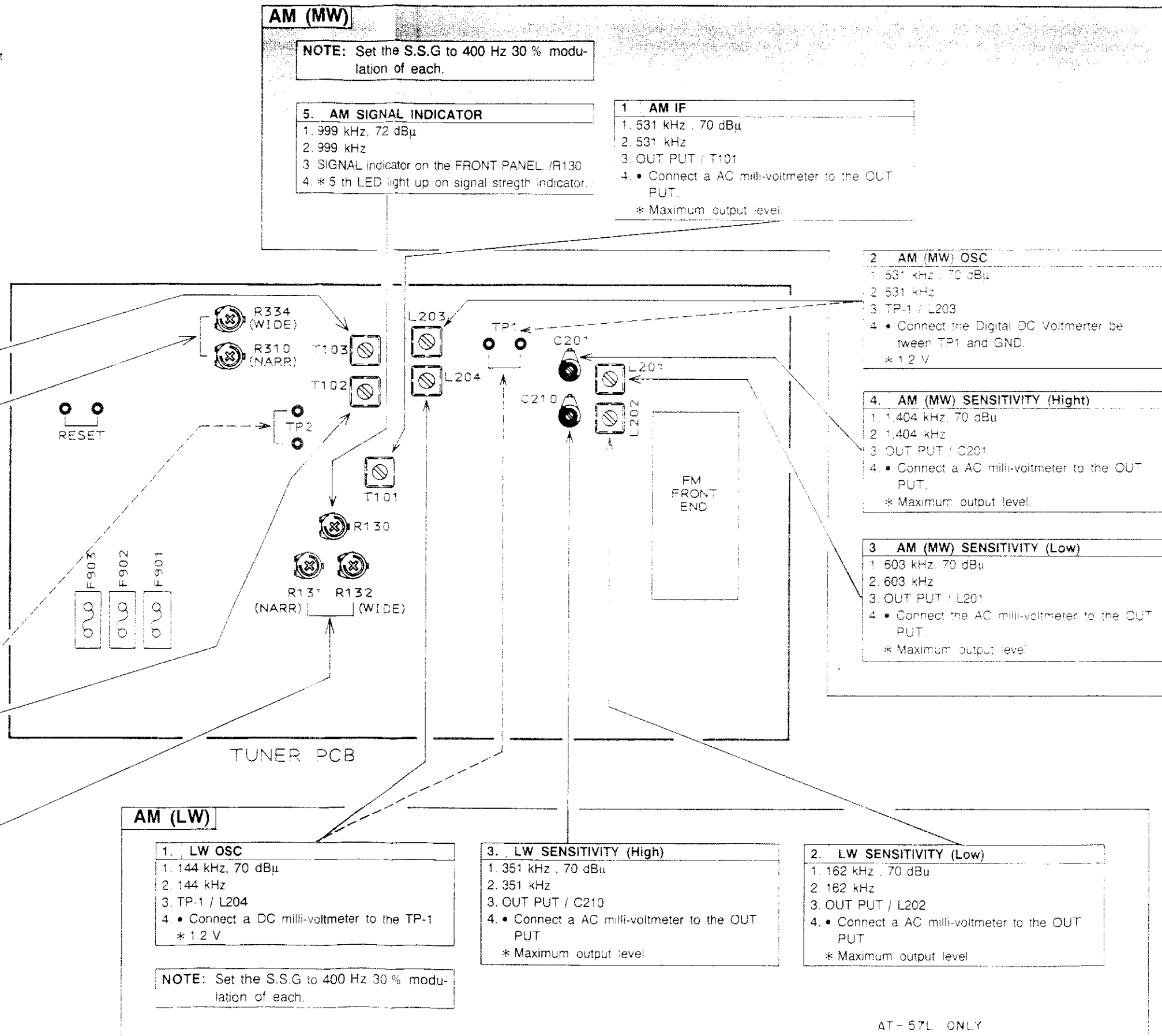

AT-57L ONLY

FINAL ASSEMBLY

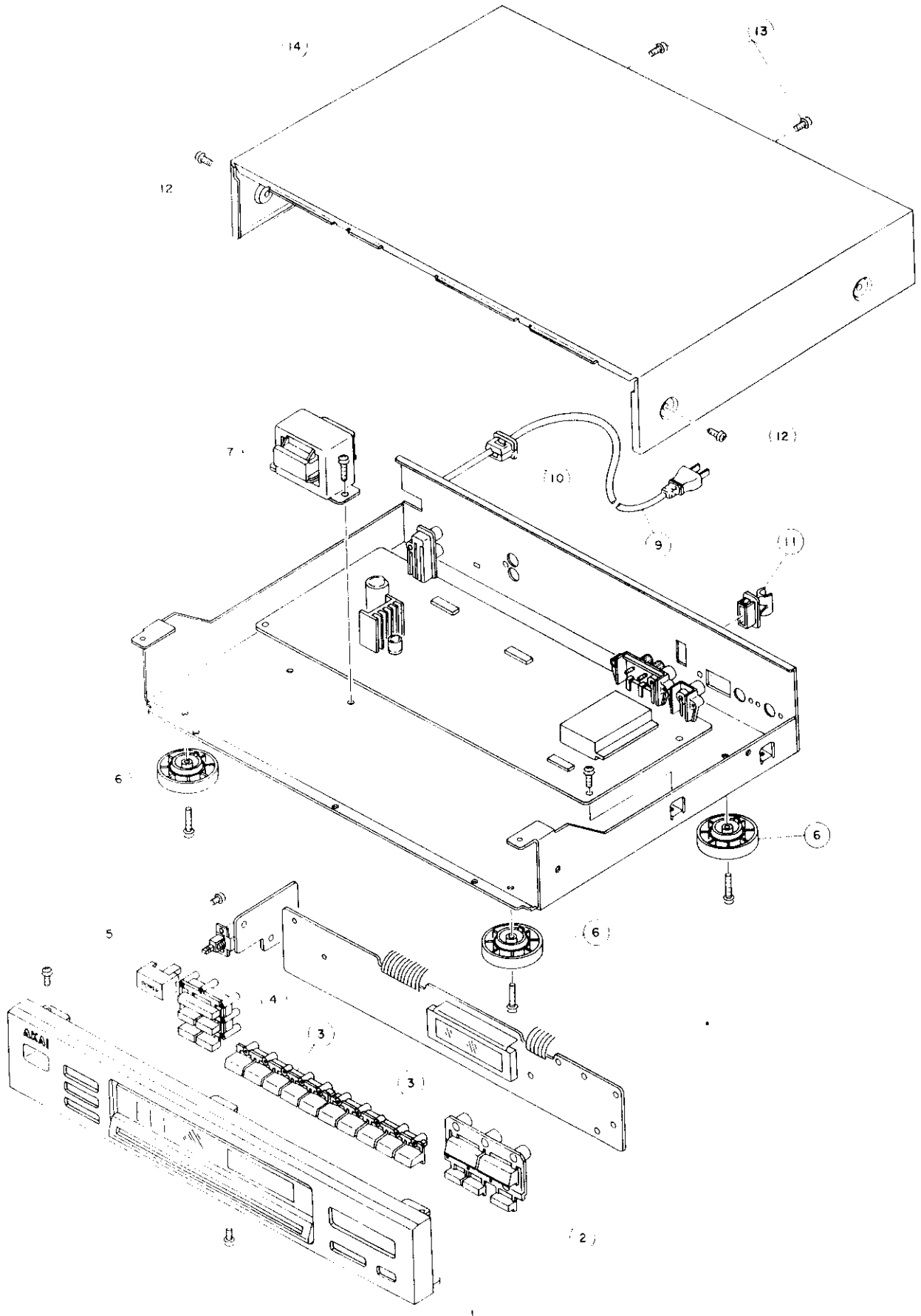

Ref.No.	Part No.	Description
Q109	ET-363326	TR FET 2SK161 GR
Q110	ET-370310	TR DTC144TS
Q111	ET-400218J	TR 2SC1740S R,S
Q112	ET-370310	TR DTC144TS
Q201	ET-400218J	TR 2SC1740S R,S [AT-57L]
Q202	ET-400218J	TR 2SC1740S R,S [AT-57L]
Q203	ET-400218J	TR 2SC1740S R,S [AT-57L]
Q204	ET-400218J	TR 2SC1740S R,S [AT-57L]
Q301	EI-729961J	IC LA3401
Q302	ET-370310	TR DTC144TS
Q303	ET-400218J	TR 2SC1740S R,S
Q304	ET-353734	TR FET 2SJ103 GR,BL
Q305	ET-400218J	TR 2SC1740S R,S
Q306	ET-400218J	TR 2SC1740S R,S
Q307	ET-338565	TR 2SD1302 R,S
Q308	ET-338565	TR 2SD1302 R,S
Q411	ET-359827	TR FET 2SK246 BL
Q412	ET-400218J	TR 2SC1740S R,S
Q413	EI-361622	IC LM7001
Q414	ET-400218J	TR 2SC1740S R,S
Q415	ET-389803J	TR 2SA933S R,S
Q416	ET-400218J	TR 2SC1740S R,S [AT-57L]
Q417	ET-389803J	TR 2SA933S R,S [AT-57L]
Q901	*EI-386309J	IC NJM7812A
Q902	*EI-728465K	IC MC7805AC
Q903	ET-370310	TR DTC144TS
Q904	ET-389803J	TR 2SA933S R,S
Q905	ET-400218J	TR 2SC1740S R,S
Q906	ET-370310	TR DTC144TS
Q907	ET-389803J	TR 2SA933S R,S
R009	*ER-303840	R OMF H FS 1W 470J
R123	*ER-303840	R OMF H FS 1W 470J
R130	EV-358829	R S-FIX H RH0615C 0.10W 223
R131	EV-356582	R S-FIX H RH0615C 0.10W 473
R132	EV-356582	R S-FIX H RH0615C 0.10W 473
R140	*ER-328278	R FUSE H ERD2FC 1/4W 10R0G
R302	*ER-328278	R FUSE H ERD2FC 1/4W 10R0G
R310	EV-357619	R S-FIX H RH0615C 0.10W 104
R334	EV-357619	R S-FIX H RH0615C 0.10W 104
R904	*ER-341331	R OMF H S15 FS 1W 181J
T101	EO-729949J	COIL IFT AM-M-CE
T102	EO-729947J	COIL IFT FM-T2
T103	EO-729946J	COIL IFT FM-T1
Z001	EE-732796J	FRONT END FM-FTZ AT-57
Z101	EH-338338	FILTER CE SFE10.7MS3GK-A
Z102	EH-338338	FILTER CE SFE10.7MS3GK-A
Z103	EH-729952J	FILTER CE 10.7
Z104	EH-729952J	FILTER CE 10.7
Z105	EH-344434	FILTER CE BFU450C4N 0.450MHZ
Z106	EO-729948J	COIL AM
Z301	EH-729945J	FILTER LP
Z302	EH-729945J	FILTER LP
Z303	EI-349970	OSC CE CSB456F11 0.456MHZ
Z402	EI-344422	OSC XTAL HC-18/U 7.200MHZ

4. CONTROL P.C BOARD

Ref.No.	Part No.	Description
B401	EZ-729962J	BATTERY CR2032THA
D401	ED-307572	D SILICON H 1SS131
D402	ED-307572	D SILICON H 1SS131
D403	ED-307572	D SILICON H 1SS131
D404	ED-307572	D SILICON H 1SS131
D405	ED-307572	D SILICON H 1SS131
D406	ED-307572	D SILICON H 1SS131
D414	ED-307572	D SILICON H 1SS131 [AT-57]
D416	ED-307572	D SILICON H 1SS131
D417	ED-307572	D SILICON H 1SS131
D418	ED-307572	D SILICON H 1SS131
D419	ED-360236	D LED GL-5EG8 GREEN
D420	ED-360236	D LED GL-5EG8 GREEN
D421	ED-360236	D LED GL-5EG8 GREEN
D422	ED-360236	D LED GL-5EG8 GREEN
D423	ED-360236	D LED GL-5EG8 GREEN
D424	ED-360236	D LED GL-5EG8 GREEN
D425	ED-360236	D LED GL-5EG8 GREEN
D426	ED-360236	D LED GL-5EG8 GREEN
D427	ED-360236	D LED GL-5EG8 GREEN
F401	EM-390703J	IND FL FV361 CHARACTER
Q401	EI-732797J	IC TMP47C410N 1394
Q402	ET-370310	TR DTC144TS
Q403	ET-370310	TR DTC144TS
Q404	ET-370310	TR DTC144TS
Q405	ET-370310	TR DTC144TS
Q418	EI-715106	IC BA6154
Q422	ET-390397J	DETECTOR GP1U501
S401	ES-729963J	SW TACT 01C1PE [ANT A/B]
S402	ES-729963J	SW TACT 01C1PE [AUTO/MANU]
S403	ES-729963J	SW TACT 01C1PE [PRESET]
S404	ES-729963J	SW TACT 01C1PE [9/19/29]
S405	ES-729963J	SW TACT 01C1PE [0/10/20/30]
S406	ES-729963J	SW TACT 01C1PE [DIRECT]
S407	ES-729963J	SW TACT 01C1PE [TUNING UP]
S408	ES-729963J	SW TACT 01C1PE [TUNING DOWN]
S409	ES-729963J	SW TACT 01C1PE [BAND]
S410	ES-729963J	SW TACT 01C1PE [FM AUTO]
S411	ES-729963J	SW TACT 01C1PE [MEMO]
S412	ES-729963J	SW TACT 01C1PE [IF BAND]
S413	ES-729963J	SW TACT 01C1PE [5/15/25]
S414	ES-729963J	SW TACT 01C1PE [6/16/26]
S415	ES-729963J	SW TACT 01C1PE [7/17/27]
S416	ES-729963J	SW TACT 01C1PE [8/18/28]
S417	ES-729963J	SW TACT 01C1PE [1/11/21]
S418	ES-729963J	SW TACT 01C1PE [2/12/22]
S419	ES-729963J	SW TACT 01C1PE [3/13/23]
S420	ES-729963J	SW TACT 01C1PE [4/14/24]
Z401	EI-382875J	OSC CE CST4.00MGW 4MHZ

5. POWER SW P.C BOARD

Ref.No.	Part No.	Description
S901	*ES-729964J	SW PUSH [POWER SW]

6. FINAL ASSEMBLY

Ref.No.	Part No.	Description
1-B	BD-732792J	PANEL FRONT BLK AT-57B
1-G	BD-732793J	PANEL FRONT BLK AT-57G
2-B	SK-731762J	KNOB TUNING (B)
2-G	SK-729971J	KNOB TUNING (G)
3-B	SK-731763J	KNOB PRESET (B)
3-G	SK-729972J	KNOB PRESET (G)
4-B	SK-731761J	KNOB ANT (B)
4-G	SK-729970J	KNOB ANT (G)
5-B	SK-373236B	KNOB POWER-B
5-G	SK-373236A	KNOB POWER-G
6	SA-379375	FOOT (N)
7A	*BT-729935J	TRANS POW AT-56 (E.V)
7B	*BT-729938J	TRANS POW AT-56 (B)
9A	*EW-347897	AC CORD 2 CORES VM0364,LCFL EV [E.V]
9B	*EW-346249	AC CORD 2 CORES LCFL2X0.75 B [B]
10	*EZ-371605	BUSH CORD 2271
11	SZ-731764J	HOLDER ANT
12	ZS-322580	ST BID40X08STL BNI
13	ZS-308846	T2BR30X08STL BZN PROJECTION
14-B	SP-368689B	COVER UPPER-B
14-G	SP-368689A	COVER UPPER-G

NOTE:

Parts will not be supplied if they are not listed in the parts list, even if they appear on the assembling illustrations with reference No.

7. ACCESSORY

Ref.No.	Part No.	Description
1	EE-729968J	ANT LOOP 3110
2	EE-729969J	ANT FM

MEMO

ABBREVIATIONS (TUNER)

ABBREVIATION	EXPLANATION	ABBREVIATION	EXPLANATION
AFC	Auto Frequency Control	MEMO	MEMOry
AGC	Auto Gain Control	MI-COM	Micro-COMputer
ALC	Auto Level Control	MIN	MINimum
AM	Amplitude Modulation	MIX	MIXing
AMP	AMPLifier	MPX	Multi pleX
ANT	ANTenna	MW	Medium Wave (frequency)
BATT	BATTerY	NC	No Connection
BLK	BLock	NFB	Negative Feed Back
BUFF	BUFFer	OSC	OSCillator
COMP	COMPalator	PCB	Printed Circuit Board
DET	DETECT (DETECTor)	PLL	Phase Locked Loop
FLD	FLuorescent Display	Q.D	Quadrature Detector
FM	FREquency Modulation	Rch	Right channel
FREQ	FREQuency	REF	REFerence
GND	GrouND	REG	REGulator
H	High	RF	Radio Frequency
HPF	High Pass Filter	SEG	SEGment
IF	Intermediate Frequency	SELE	SELEctor
IHF	Institut of High Fidelity	SENS	SENSitivity
IND	INDicator	SIG	SIGnal
I/O	In/Out	S/N	Signal to Noise Ratio
JW	Jumper Wire	SSG	Standard Signal Generator
L	Low	STD	STanDard
LCD	Liquid Crystal Display	SW	SWitch: Short Wave (frequency)
Lch	Left channel	THD	Total Harmonic Distortion
LED	Light Emiting Diode	TP	Test Point
LPF	Low Pass Filter	VCO	Voltage Controlled Oscillator
LW	Long Wave (Frequency)	VR	Variable Resistor
		X'TAL	Crystal

AKAI

MODEL **AT-57/L**

SCHEMATIC DIAGRAMS AND PC BOARDS

TABLE OF CONTENTS

1. FRONT END SCHEMATIC DIAGRAM	2
2. BLOCK DIAGRAM	3
3. SCHEMATIC DIAGRAM	4
4. TUNER P.C BOARD	5
5. OPERATION PC BOARD	6

Use the following schematic diagrams and PC boards together with the provided service manual.

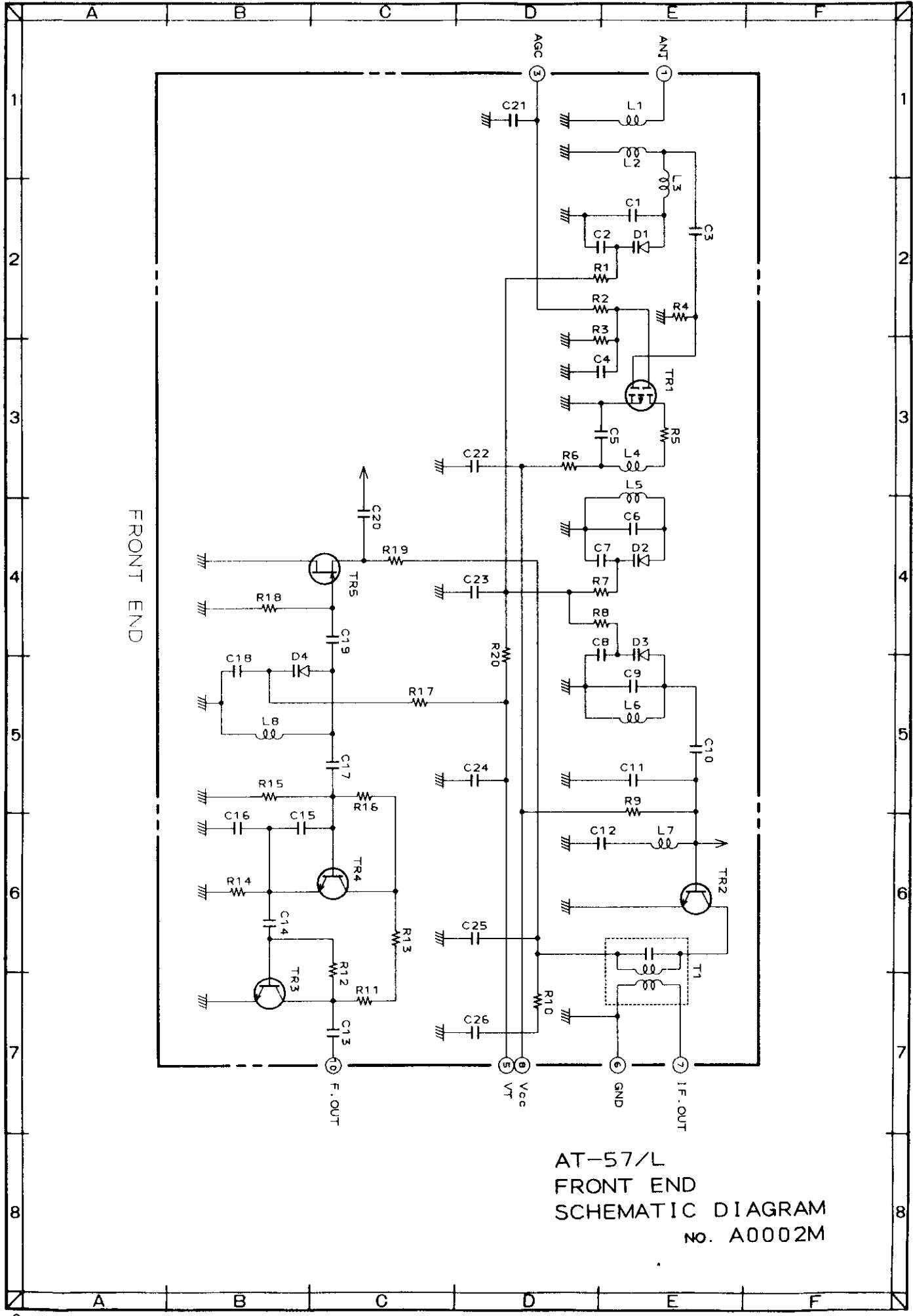

AT-57/L
FRONT END
SCHEMATIC DIAGRAM
NO. A0002M

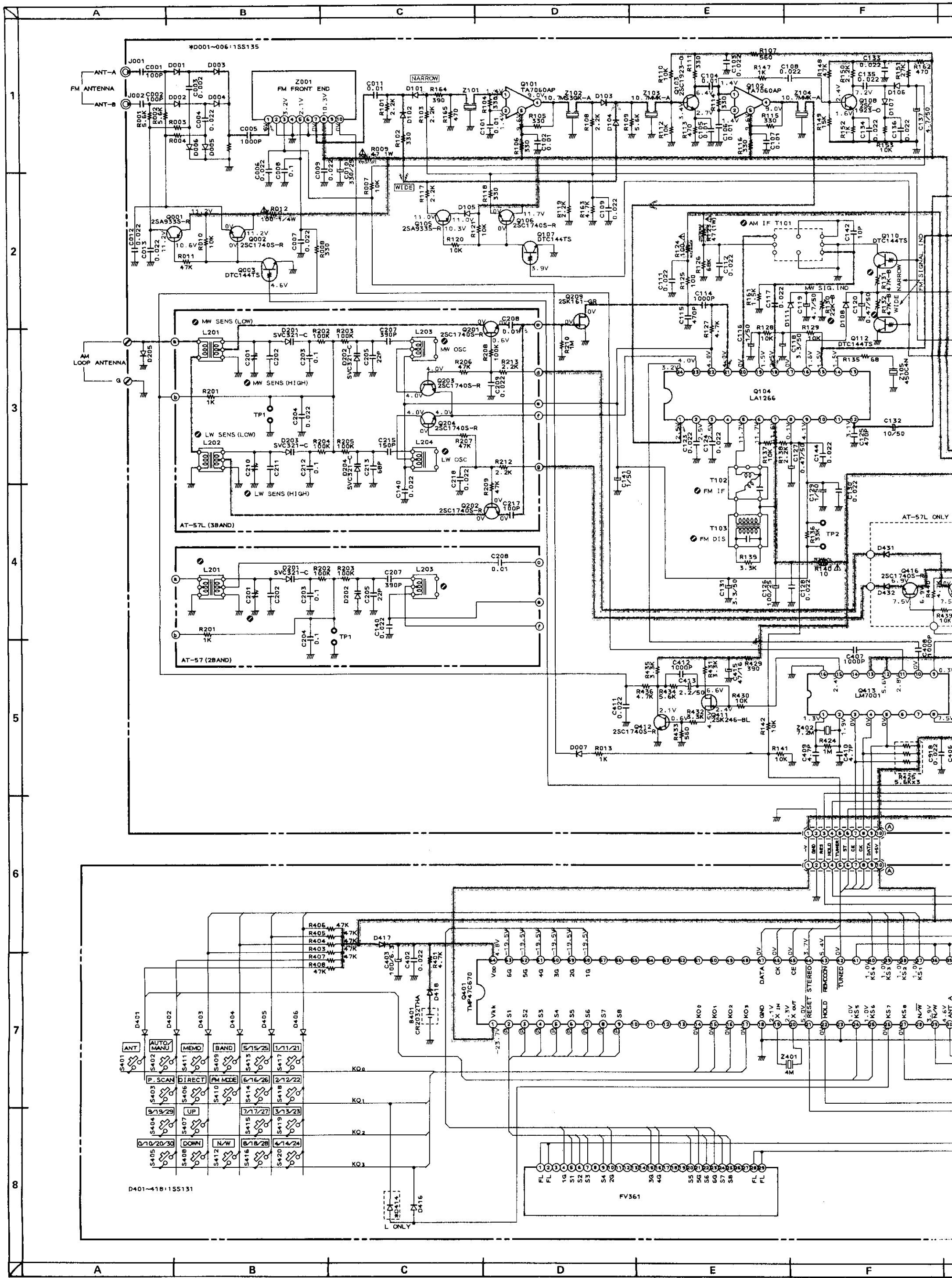

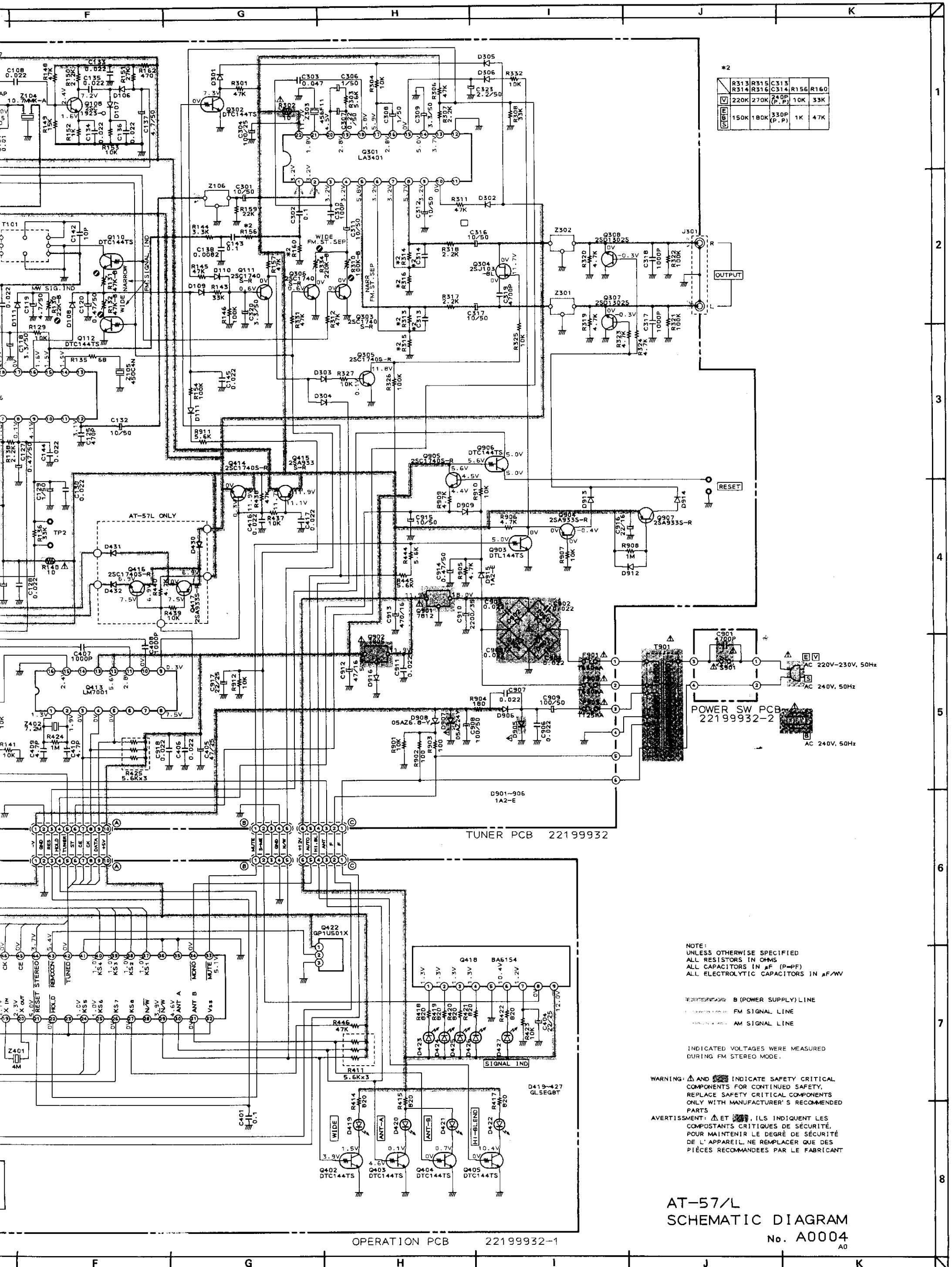

#2

R313	R315	C313	R156	R160
R314	R316	C314	10K	33K
220K	270K	240P (P.P)		
150K	180K	330P (P.P)	1K	47K

POWER SW PCB
22199932-2

AC 220V-230V, 50Hz
AC 240V, 50Hz
AC 240V, 50Hz

TUNER PCB 22199932

OPERATION PCB 22199932-1

NOTE:
UNLESS OTHERWISE SPECIFIED
ALL RESISTORS IN OHMS
ALL CAPACITORS IN μ F (P-PF)
ALL ELECTROLYTIC CAPACITORS IN μ F/W

⊠ (POWER SUPPLY) LINE
⊡ FM SIGNAL LINE
⊢ AM SIGNAL LINE

INDICATED VOLTAGES WERE MEASURED
DURING FM STEREO MODE.

WARNING: ⚠ AND ⚡ INDICATE SAFETY CRITICAL COMPONENTS FOR CONTINUED SAFETY. REPLACE SAFETY CRITICAL COMPONENTS ONLY WITH MANUFACTURER'S RECOMMENDED PARTS

AVERTISSEMENT: ⚠ ET ⚡ ILS INDIQUENT LES COMPOSANTS CRITIQUES DE SÉCURITÉ. POUR MAINTENIR LE DEGRÉ DE SÉCURITÉ DE L'APPAREIL, NE REMPLACER QUE DES PIÈCES RECOMMANDÉES PAR LE FABRICANT

AT-57/L
SCHEMATIC DIAGRAM
No. A0004
A0

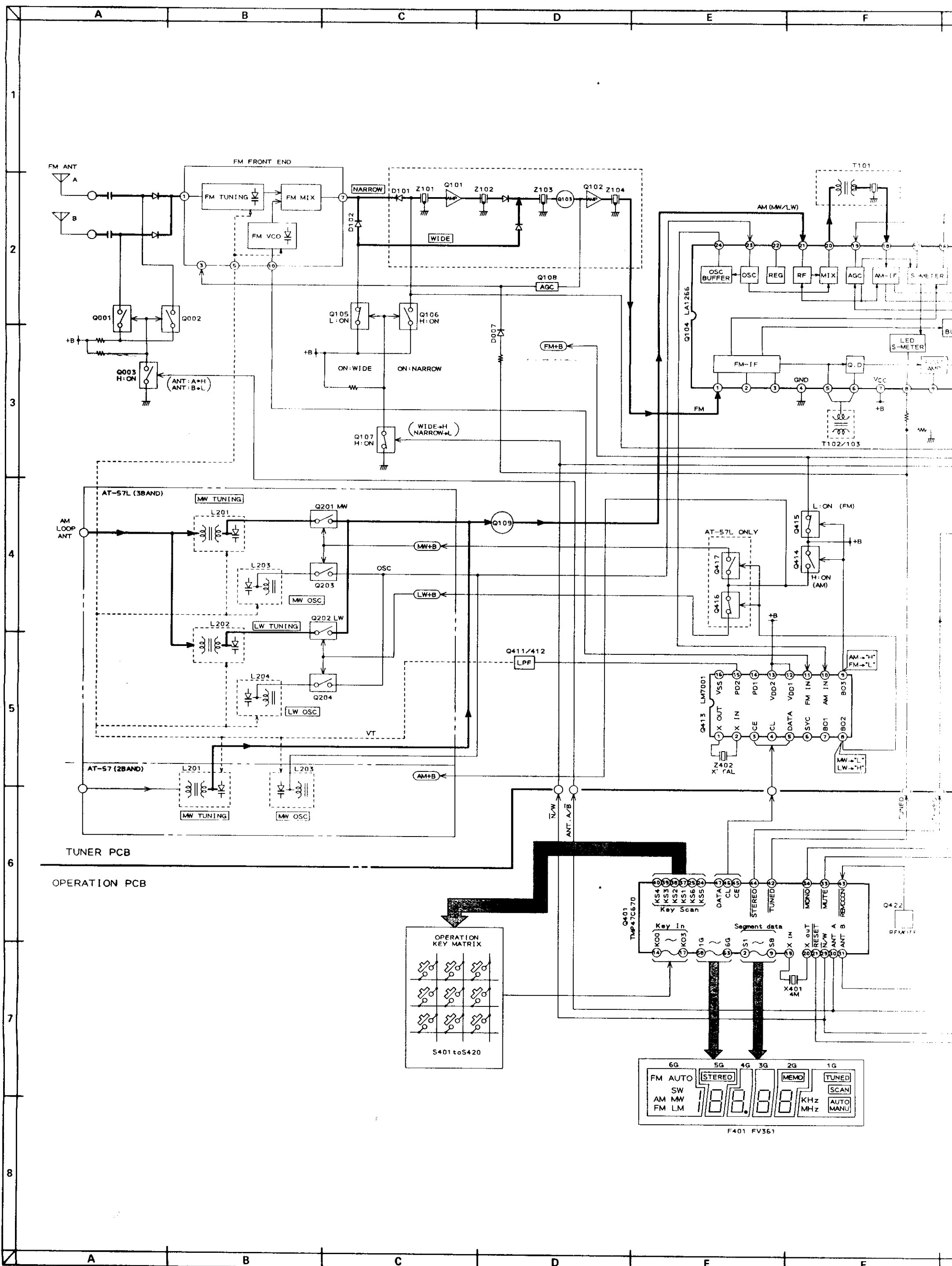

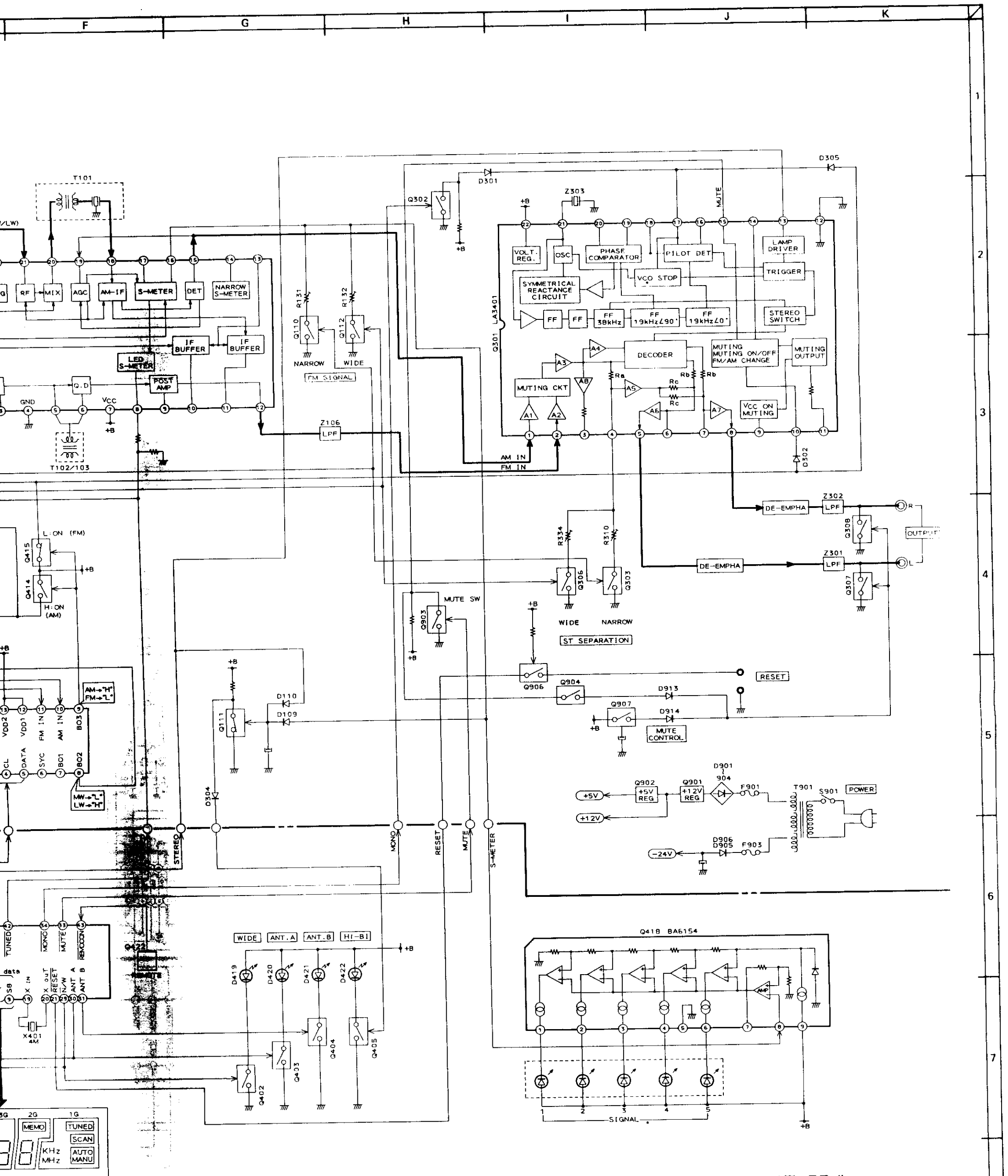

AT-57/L
 BLOCK DIAGRAM
 No. A0005
 A1

8

PRINCIPAL PARTS LOCATION

ICs			
Q101	B4	Q108	B4
Q102	A4	Q110	B3
Q104	A3	Q111	A3
Q301	A2	Q112	B3
Q413	B5	Q201	A4
Q901	B2	Q202	A4
Q902	B2	Q203	A3
		Q204	A3
		Q209	A4
		Q302	B3
		Q303	A2
		Q304	A2
		Q305	B2
		Q306	A2
		Q307	A1
		Q308	A1

TRANSISTORS			
Q001	A5	Q904	A1
Q002	A5	Q905	B3
Q003	A5	Q906	B3
Q103	B4	Q907	A1
Q105	A4		
Q106	A4		
Q107	A4		

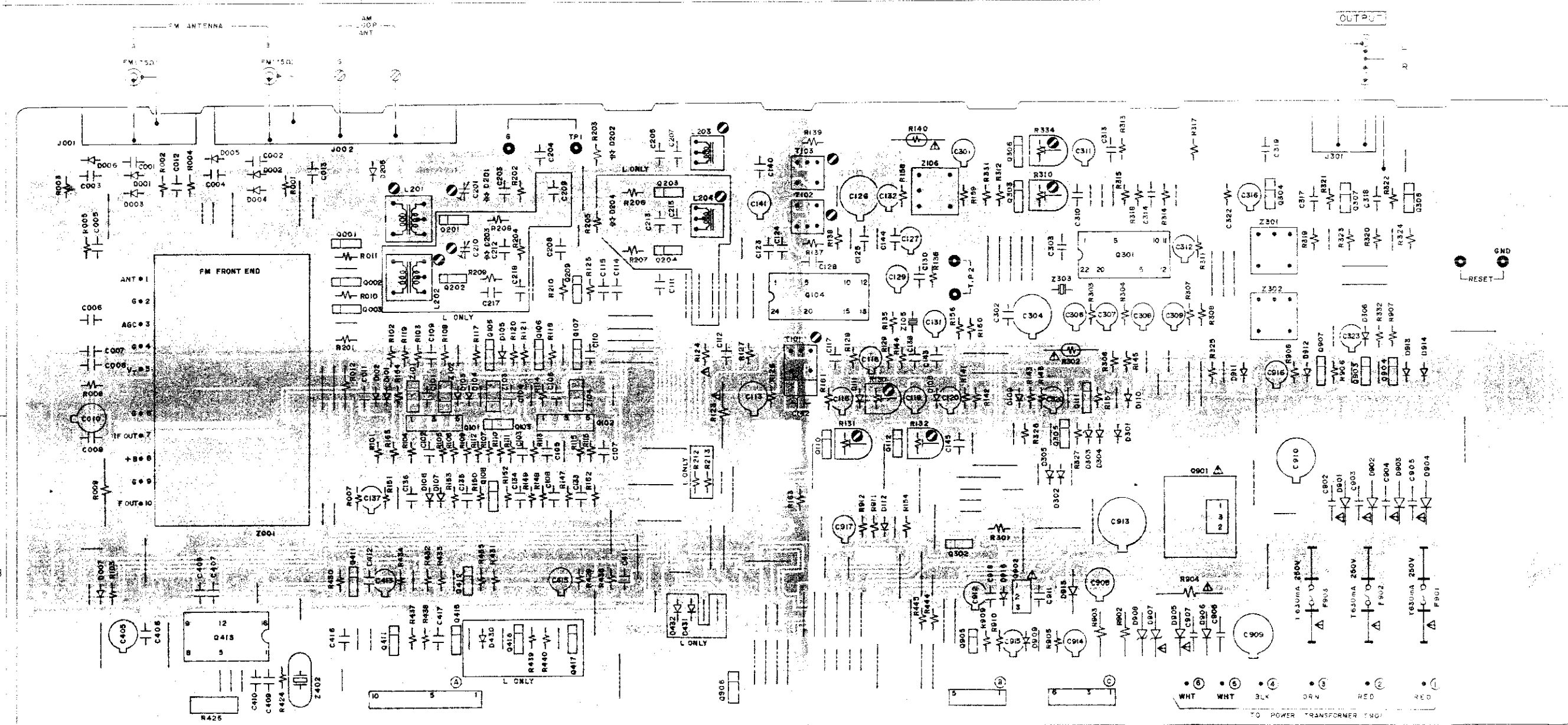

TUNER PCB 22199932

WARNING: * INDICATES SAFETY CRITICAL COMPONENTS FOR CONTINUED SAFETY.
 REPLACE SAFETY CRITICAL COMPONENTS ONLY WITH MANUFACTURER'S
 RECOMMENDED PARTS.
 AVERTISSEMENT: * INDICOLE LES COMPOSANTS CRITIQUES DE SECURITE.
 NE REMPLACEZ QUE LES COMPOSANTS CRITIQUES RECOMMENDES PAR LE FABRICANT.

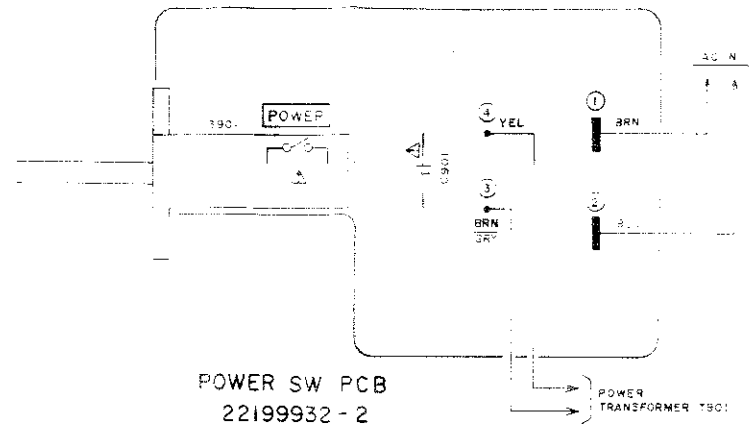

WARNING: NO LATEST SAFETY RELATED COMPONENTS (IF AVAILABLE, SAFETY RELATED SAFETY OR LATEST COMPONENTS ONLY) MANUFACTURER'S RECOMMENDED PARTS.
AVERTISSEMENT: NE PAS INSÉRER DES COMPOSANTS D'ÉLECTRONIQUE DE SÉCURITÉ (SI DISPONIBLES, DES COMPOSANTS D'ÉLECTRONIQUE DE SÉCURITÉ SEULEMENT) NI DES PIÈCES RECOMMANDÉES PAR LE FABRICANT.

