

Service Manual

PIONEER®
The Art of Entertainment

DEH-59DH



ORDER NO.
CRT1968

HIGH POWER CD PLAYER WITH FM/AM TUNER

DEH-59DH UC

DEH-45DH UC

COMPACT
disc
DIGITAL AUDIO

- See the separate manual CX-597(CRT1829) for the CD mechanism description, disassembly and circuit description.
- The CD mechanism employed in this model is one of CX-597 series.

● CD Player Service Precautions

1. For pickup unit(CXX1230) handling, please refer to "Disassembly"(CX-597 Service Manual CRT1829). During replacement, handling precautions shall be taken to prevent an electrostatic discharge(protection by a short pin).
2. During disassembly, be sure to turn the power off since an internal IC might be destroyed when a connector is plugged or unplugged.

CONTENTS

1. SAFETY INFORMATION	2	7. GENERAL INFORMATION	58
2. EXPLODED VIEWS AND PARTS LIST	2	7.1 PARTS	58
3. SCHEMATIC DIAGRAM	12	7.1.1 IC.....	58
4. PCB CONNECTION DIAGRAM	32	7.1.2 DISPLAY	68
5. ELECTRICAL PARTS LIST	43	7.2 DIAGNOSIS	69
6. ADJUSTMENT.....	51	7.2.1 DISASSEMBLY	69
		7.2.2 TEST MODE	70
		7.3 BLOCK DIAGRAM	72
		8. OPERATIONS AND SPECIFICATIONS.....	74

PIONEER ELECTRONIC CORPORATION 4-1, Meguro 1-Chome, Meguro-ku, Tokyo 153, Japan
PIONEER ELECTRONICS SERVICE INC. P.O.Box 1760, Long Beach, CA 90801-1760 U.S.A.
PIONEER ELECTRONIC [EUROPE] N.V. Haven 1087 Keetberglaan 1, 9120 Melsele, Belgium
PIONEER ELECTRONICS ASIACENTRE PTE.LTD. 501 Orchard Road, #10-00, Lane Crawford Place, Singapore 0923

© PIONEER ELECTRONIC CORPORATION 1997

K-FFS. JAN. 1997 Printed in Japan

1. SAFETY INFORMATION

CAUTION

This service manual is intended for qualified service technicians; it is not meant for the casual do-it-yourselfer. Qualified technicians have the necessary test equipment and tools, and have been trained to properly and safely repair complex products such as those covered by this manual. Improperly performed repairs can adversely affect the safety and reliability of the product and may void the warranty. If you are not qualified to perform the repair of this product properly and safely; you should not risk trying to do so and refer the repair to a qualified service technician.

WARNING

Lead in solder used in this product is listed by the California Health and Welfare agency as a known reproductive toxicant which may cause birth defects or other reproductive harm (California Health & Safety Code, Section 25249.5). When servicing or handling circuit boards and other components which contain lead in solder, avoid unprotected skin contact with the solder. Also, when soldering do not inhale any smoke or fumes produced.

2. EXPLODED VIEWS AND PARTS LIST

2.1 PACKING

● DEH-59DH

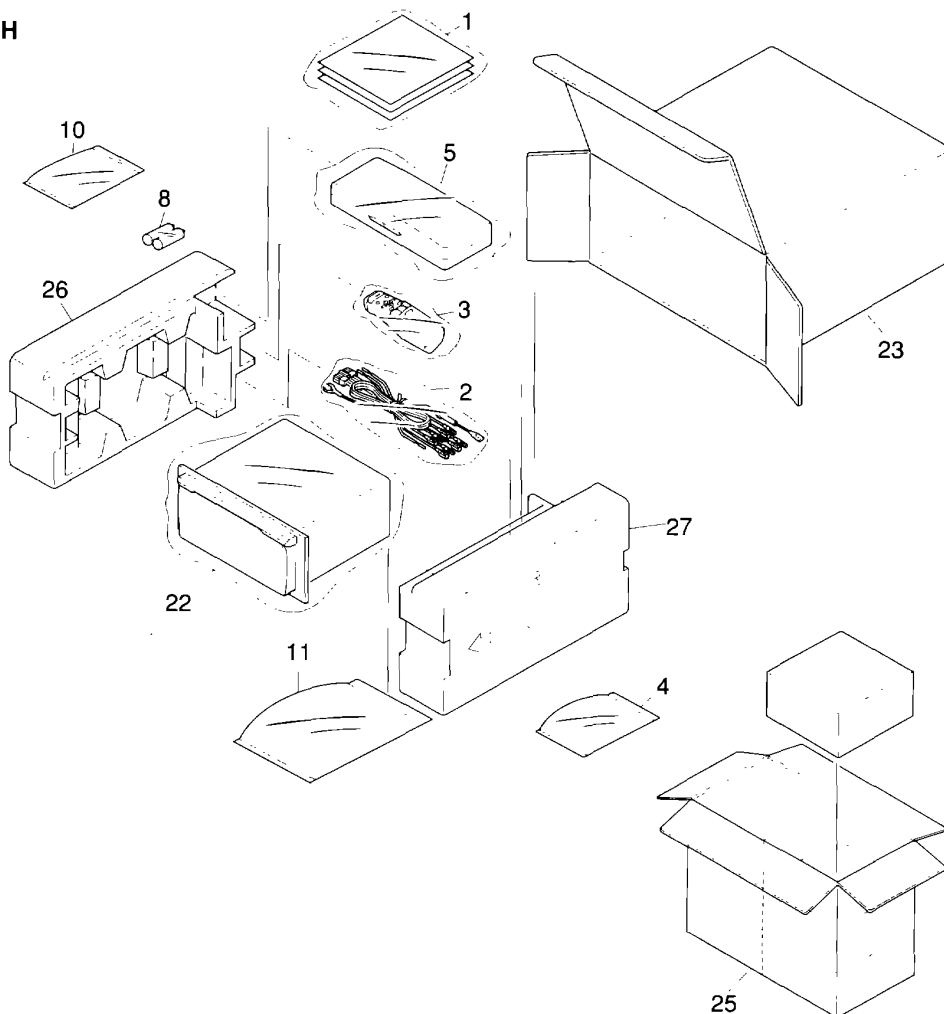

Fig. 1

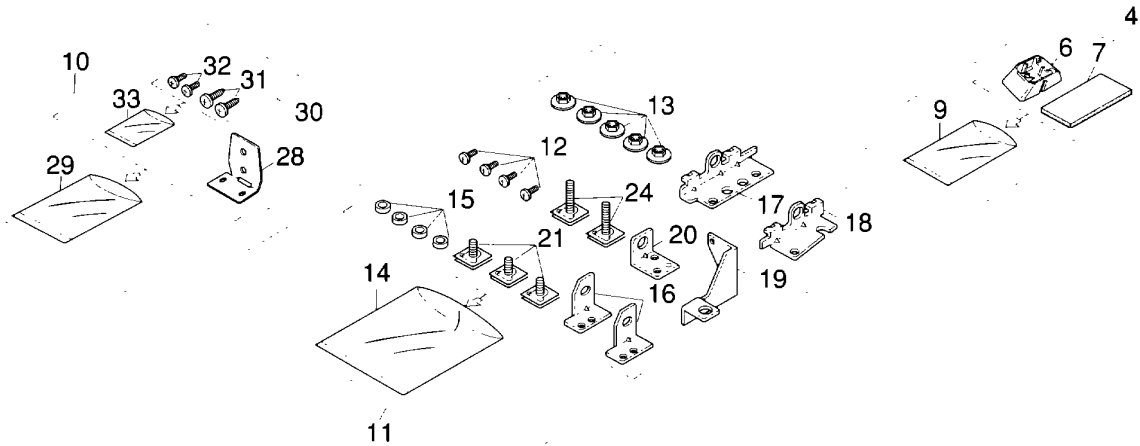

Fig. 2

NOTE:

- Parts marked by “*” are generally unavailable because they are not in our Master Spare Parts List.
- Screws adjacent to ▼ mark on the product are used for disassembly.

● Parts List

Mark No.	Description	Part No.	Mark No.	Description	Part No.
1-1	Owner's Manual (English,French)	CRD2252	21	Bolt Unit(x3)	CXA7960
1-2	Installation Manual (English,French)	CRD2363	22	Cover	CEG1228
1-3	Polyethylene Bag	CEG1116	23	Carton	CHG3206
*	1-4 Warranty Card	CRY1070	24	Bolt Unit(x2)	CXA7961
	2 Cord	CDE4670	25	Contain Box	CHL3206
	3 Remote Control Assy	CXB1160	26	Protector(L)	CHP1910
	4 Base Assy	CEA2344	27	Protector(R)	CHP1911
	5 Case Assy	CXB1141	28	Bracket	CZN6467
*	6 Base	CZN6466	*	29 Polyethylene Bag	CZE3201
*	7 Sheet	CZN3371	30	Screw Assy	CZE3198
*	8 Battery	CEX1006	31	Screw(x2)	BNC40P120FZK
*	9 Polyethylene Bag	CZE3188	*	32 Screw(x2)	BPZ30P100FZK
*	10 Bracket Assy	CEA2346	*	33 Polyethylene Bag	CEG-127
	11 Accessory Assy	CEA2006			
	12 Screw(x4)	BSZ30P050FMC			
	13 Nut(x5)	CBN1012			
*	14 Polyethylene Bag	CEG1101			
	15 Spacer(x4)	CLA2598			
	16 Bracket(x2)	CNC6767			
	17 Bracket	CNC5506			
	18 Bracket	CNC5507			
	19 Bracket	CNC5686			
	20 Bracket	CNC5687			

DEH-59DH,45DH

● DEH-45DH

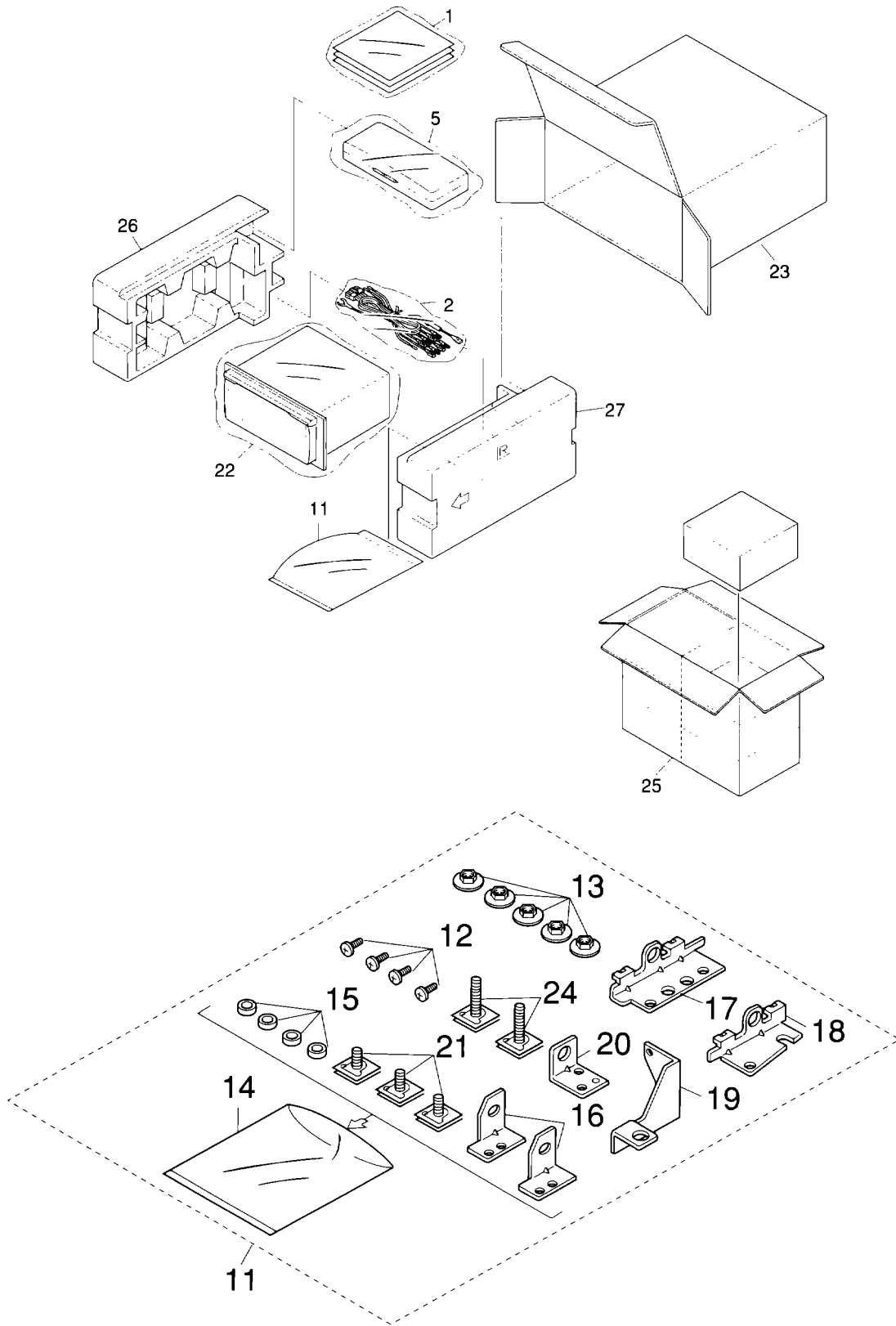

Fig. 3

● **Parts List**

Mark	No.	Description	Part No.
*	1-1	Card	ARY1048
	1-2	Owner's Manual (English,French)	CRD2250
	1-3	Installation Manual (English,French)	CRD2251
	1-4	Polyethylene Bag	CEG1116
	2	Cord	CDE4670
	3,4	
	5	Case Assy	CXB1415
	6-10	
	11	Accessory Assy	CEA2006
	12	Screw(x4)	BSZ30P050FMC
	13	Nut(x5)	CBN1012
*	14	Polyethylene Bag	CEG1101
	15	Spacer(x4)	CLA2598
	16	Bracket(x2)	CNC6767
	17	Bracket	CNC5506
	18	Bracket	CNC5507
	19	Bracket	CNC5686
	20	Bracket	CNC5687
	21	Bolt Unit(x3)	CXA7960
	22	Cover	CEG1228
	23	Carton	CHG3205
	24	Bolt Unit(x2)	CXA7961
	25	Contain Box	CHL3205
	26	Protector(L)	CHP1910
	27	Protector(R)	CHP1911

DEH-59DH,45DH

2.2 EXTERIOR

● DEH-59DH

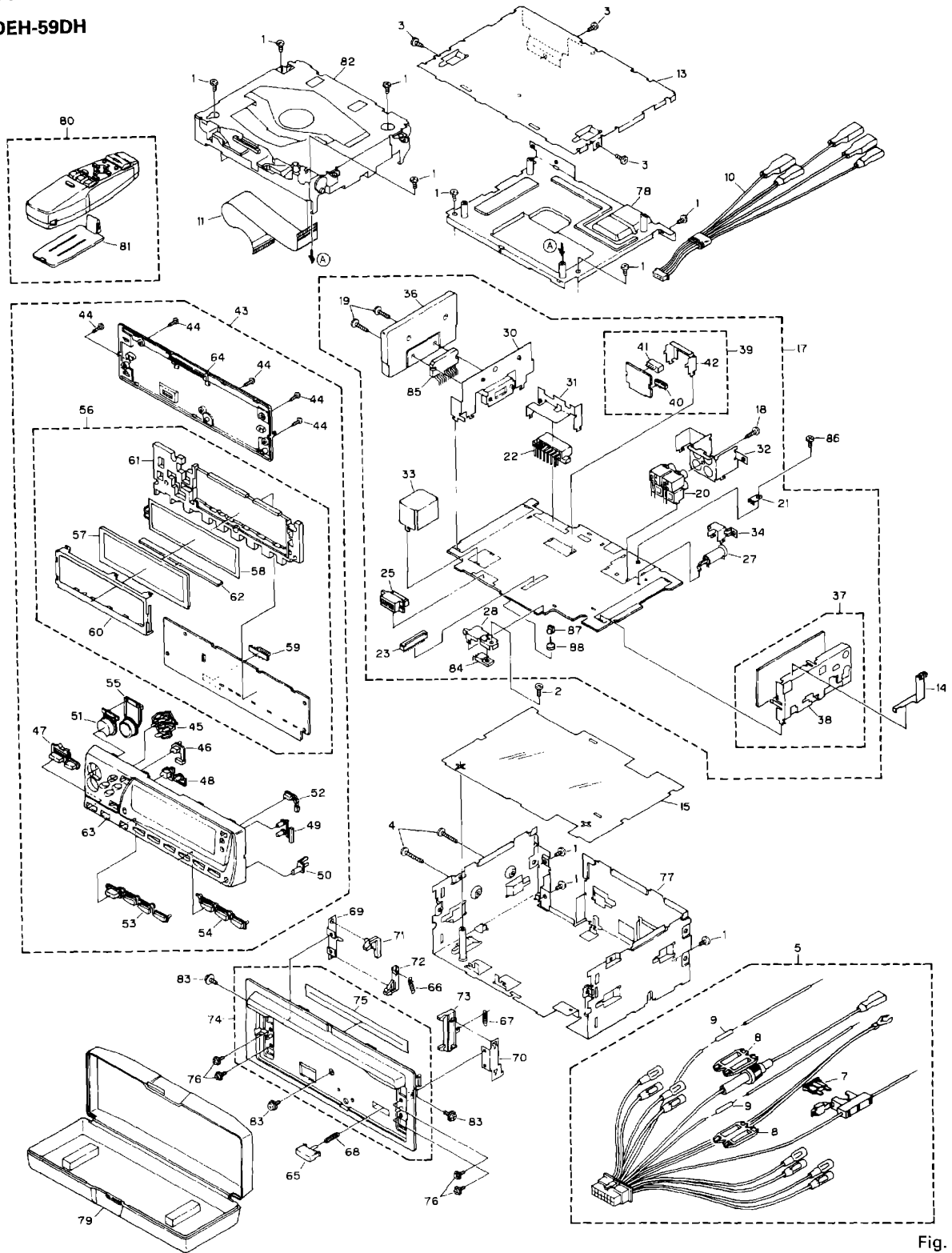

Fig. 4

● Parts List

Mark No.	Description	Part No.	Mark No.	Description	Part No.
1	Screw	BSZ26P060FMC	46	Button(FUNC)	CAC4887
2	Screw	BSZ26P080FMC	47	Button(SOURCE)	CAC4888
3	Screw	BSZ30P050FMC	48	Button(AUDIO)	CAC4889
4	Screw	BSZ30P200FMC	49	Button(LOUD,CLOCK)	CAC4893
5	Cord	CDE4670	50	Button(DETACH)	CAC4894
6		51	Button(+)	CAC4885
7	Fuse(10A)	CEK1136	52	Button(EJECT)	CAC4892
8	Cap	CNS1472	53	Button(1,2,3,DISP)	CAC4890
9	Resistor	RS1/2PMF102J	54	Button(4,5,6)	CAC4891
10	Cord Assy	CDE5198	55	Button(-)	CAC4895
11	Cable	CDE5269	56	Key Board Unit	CWX2091
12		57	LCD	CAW1390
13	Case	CNB2123	58	EL	CEL1488
14	Holder	CNC7005	59	Connector(CN1901)	CKS3580
15	Insulator	CNM5076	60	Holder	CNC7198
16		61	Holder	CNV4772
17	Tuner Amp Unit	CWX2067	62	Connector	CNV4791
18	Screw	BPZ26P100FMC	63	Grille Unit	CXA9693
19	Screw	BSZ26P160FMC	64	Cover Unit	CXA9713
20	Pin Jack(CN251)	CKB1031	65	Button	CAC5180
21	Terminal(CN504)	CKF1059	66	Spring	CBH1834
22	Plug(CN901)	CKM1204	67	Spring	CBH1835
23	Connector(CN651)	CKS2255	68	Spring	CBH1933
24		69	Bracket	CNC6135
25	Connector(CN801)	CKS3581	70	Bracket	CNC6791
26		71	Arm	CNV4692
27	Antenna Jack(CN503)	CKX1056	72	Arm	CNV4693
28	Holder	CNC5013	73	Arm	CNV4951
29		74	Panel Unit	CXA9695
30	Holder	CNC6879	75	Cover	CNM4875
31	Holder	CNC6892	76	Screw	IMS20P040FZK
32	Holder	CNC7197	77	Chassis Unit	CXA9714
33	Holder	CNC6889	78	Chassis Unit	CXA9718
34	Holder	CNC7001	79	Case Assy	CXB1415
35		80	Remote Control Assy	CXB1160
36	Heat Sink	CNR1435	81	Battery Cover	CNS4406
37	FM/AM Tuner Unit	CWE1417	82	CD Mechanism Module(S7)	CXK5001
38	Holder	CNC6555	83	Screw	ISS26P060FZK
39	Detach Alarm Unit	CWM5291	84	Transistor(Q971)	2SD2396
40	Plug(CN852)	CKS1617	85	IC(IC201)	TDA7384A
41	Connector(CN851)	CKS3585	86	Screw	ISS26P060FMC
42	Holder	CNC6912	87	LED(D851)	BR4361F
43	Detach Grille Assy	CXA9605	88	Bush	CNV-724
44	Screw	BPZ20P100FZK			
45	Button	CAC4886			

DEH-59DH,45DH

● DEH-45DH

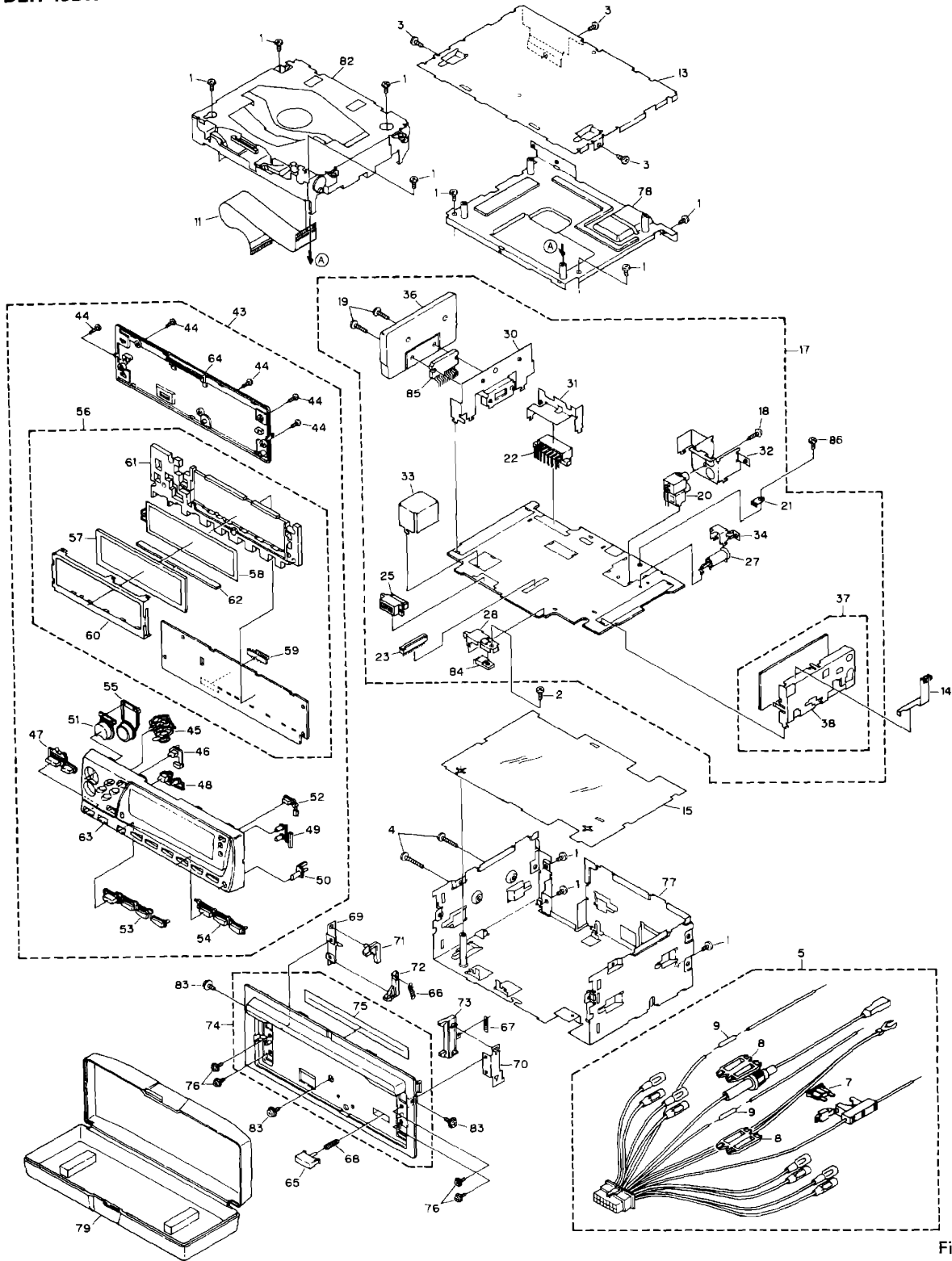

Fig. 5

● Parts List

Mark No.	Description	Part No.	Mark No.	Description	Part No.
1	Screw	BSZ26P060FMC	49	Button(LOUD,CLOCK)	CAC4893
2	Screw	BSZ26P080FMC	50	Button(DETACH)	CAC4894
3	Screw	BSZ30P050FMC	51	Button(+)	CAC4885
4	Screw	BSZ30P200FMC	52	Button(EJECT)	CAC4892
5	Cord	CDE4670	53	Button(1,2,3,DISP)	CAC4890
6		54	Button(4,5,6)	CAC4891
7	Fuse(10A)	CEK1136	55	Button(-)	CAC4895
8	Cap	CNS1472	56	Key Board Unit	CWX2091
9	Resistor	RS1/2PMF102J	57	LCD	CAW1390
10		58	EL	CEL1488
11	Cable	CDE5269	59	Connector(CN1901)	CKS3580
12		60	Holder	CNC7198
13	Case	CNB2123	61	Holder	CNV4772
14	Holder	CNC7005	62	Connector	CNV4791
15	Insulator	CNM5076	63	Grille Unit	CXA9694
16		64	Cover Unit	CXA9713
17	Tuner Amp Unit	CWX2068	65	Button	CAC5180
18	Screw	BPZ26P100FMC	66	Spring	CBH1834
19	Screw	BSZ26P160FMC	67	Spring	CBH1835
20	Pin Jack(CN251)	CKB1032	68	Spring	CBH1933
21	Terminal(CN504)	CKF1059	69	Bracket	CNC6135
22	Plug(CN901)	CKM1204	70	Bracket	CNC6791
23	Connector(CN651)	CKS2255	71	Arm	CNV4692
24		72	Arm	CNV4693
25	Connector(CN801)	CKS3581	73	Arm	CNV4951
26		74	Panel Unit	CXA9695
27	Antenna Jack(CN503)	CKX1056	75	Cover	CNM4875
28	Holder	CNC5013	76	Screw	IMS20P040FZK
29		77	Chassis Unit	CXA9715
30	Holder	CNC6879	78	Chassis Unit	CXA9718
31	Holder	CNC6893	79	Case Assy	CXB1415
32	Holder	CNC7199	80,81	
33	Holder	CNC6889	82	CD Mechanism Module(S7)	CXK5001
34	Holder	CNC7001	83	Screw	ISS26P060FZK
35		84	Transistor(Q971)	2SD2396
36	Heat Sink	CNR1435	85	IC(IC201)	TDA7384A
37	FM/AM Tuner Unit	CWE1417	86	Screw	ISS26P060FMC
38	Holder	CNC6555			
39-42	CWM5291			
43	Detach Grille Assy	CXA9606			
44	Screw	BPZ20P100FZK			
45	Button	CAC4886			
46	Button(FUNC)	CAC4887			
47	Button(SOURCE)	CAC4888			
48	Button(AUDIO)	CAC4889			

2.3 CD MECHANISM MODULE

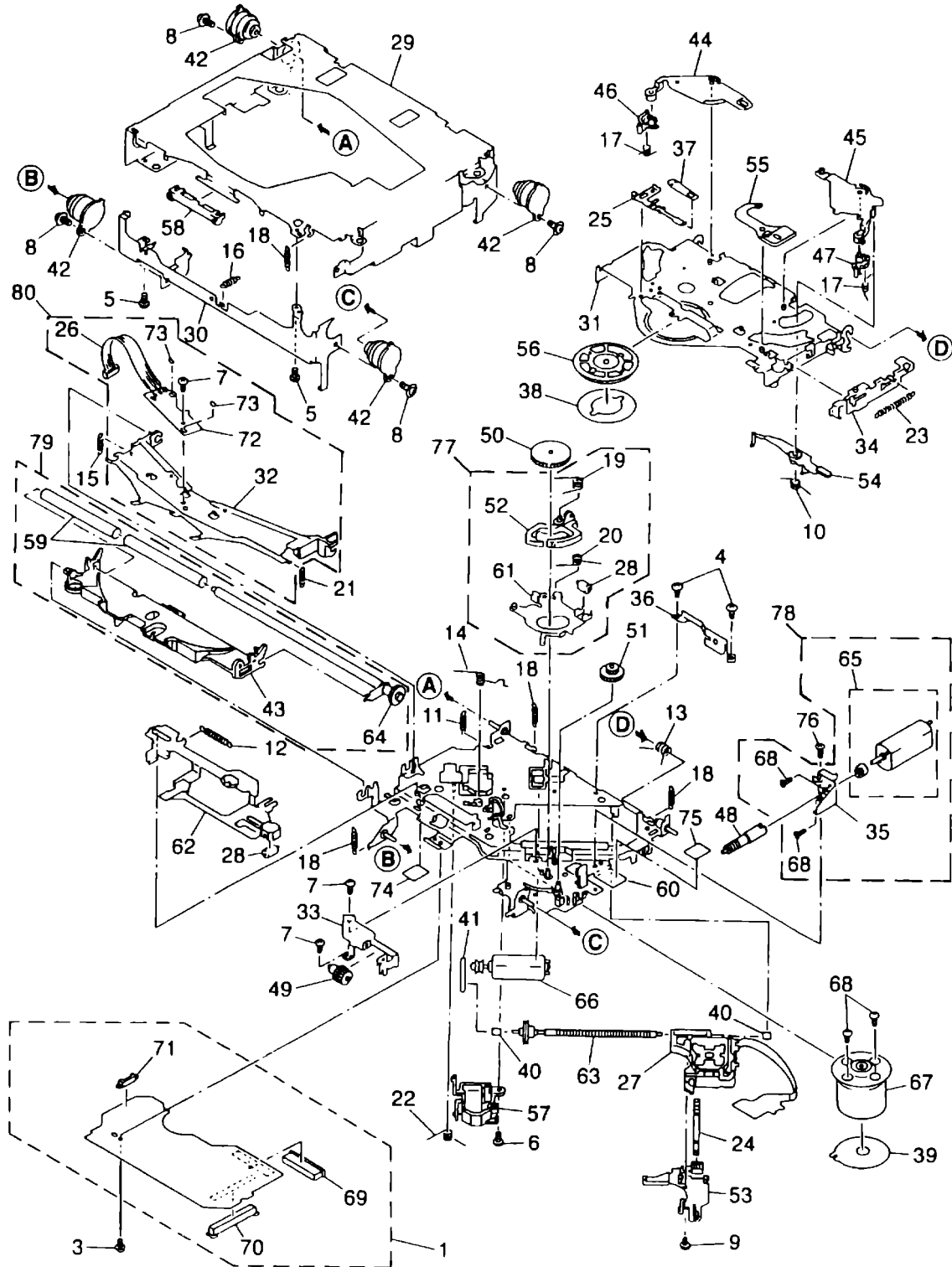

Fig. 6

● Parts List

Mark No.	Description	Part No.	Mark No.	Description	Part No.
1	Control Unit	CWX1889	46	Arm	CNV4124
2		47	Arm	CNV4125
3	Screw	IMS26P035FMC	48	Gear	CNV4128
4	Screw	BMZ20P040FMC	49	Gear	CNV4129
5	Screw	BSZ20P040FMC	50	Gear	CNV4130
6	Screw(M2X3)	CBA1077	51	Gear	CNV4131
7	Screw(M2X2)	CBA1250	52	Arm	CNV4136
8	Screw(M2X5)	CBA1296	53	Holder	CNV4663
9	Screw(M2X3.85)	CBA1362	54	Arm	CNV4138
10	Spring	CBH1945	55	Arm	CNV4139
11	Spring	CBH1724	56	Clamper	CNV4140
12	Spring	CBH1939	57	Holder	CNV4664
13	Spring	CBH1729	58	Guide	CNV4484
14	Spring	CBH1730	59	Roller	CNV4509
15	Spring	CBH1731	60	Chassis Unit	CXA9515
16	Spring	CBH1732	61	Arm Unit	CXA8565
17	Spring	CBH1736	62	Lever Unit	CXA9300
18	Spring	CBH1745	63	Screw Unit	CXA8699
19	Spring	CBH1832	64	Gear Unit	CXA8701
20	Spring	CBH1833	65	Load Motor Unit(M3)	CXA8702
21	Spring	CBH1848	66	CRG Motor Unit(M2)	CXA8986
22	Spring	CBH1849	67	Motor Unit(M1)	CXA8912
23	Spring	CBH1863	68	Screw	JFZ20P025FMC
24	Spring	CBL1214	69	Connector(CN101)	CKS1953
25	Spring	CBL1269	70	Connector(CN701)	CKS2774
26	Connector(CN1)	CDE4576	71	Connector(CN801)	CKS2196
27	Pickup Unit(Service)	CXX1230	* 72	Gathering PCB	CNX2445
28	Roller	CLA2627	73	Photo-transistor(Q1, 2)	CPT-230S-X
29	Frame	CNC5796	74	Sheet	CNM4873
30	Frame	CNC5797	75	Cushion	CNM3917
31	Arm	CNC5799	76	Screw	BMZ20P025FMC
32	Arm	CNC5801	77	ELBO Arm Assy	CXA8889
33	Bracket	CNC5871	78	Load Motor Assy	CXA8891
34	Lever	CNC6054	79	LO Arm Assy	CXA8892
35	Bracket	CNC6056	80	Guide Arm Assy	CXA8893
* 36	Bracket	CNC6376			
37	Spacer	CNM3315			
38	Sheet	CNM4849			
39	PCB	CNP4230			
40	Bearing	CNR1415			
41	Belt	CNT1071			
42	Damper	CNV3974			
43	Arm	CNV4120			
44	Arm	CNV4122			
45	Arm	CNV4123			

3. SCHEMATIC DIAGRAM

3.1 OVERALL CONNECTION DIAGRAM(GUIDE PAGE)

Note: When ordering service parts, be sure to refer to "EXPLODED VIEWS AND PARTS LIST" or "ELECTRICAL PARTS LIST".

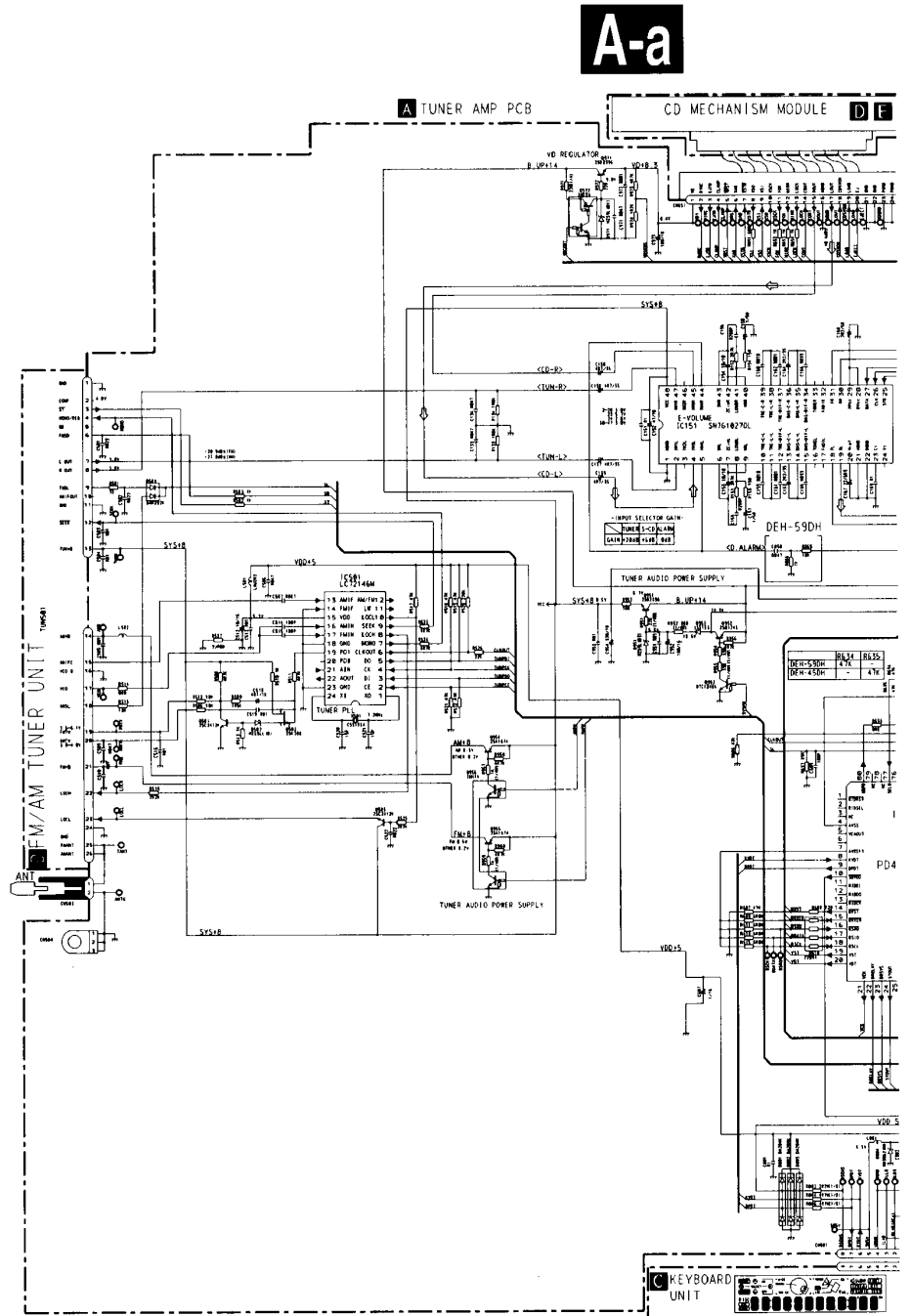
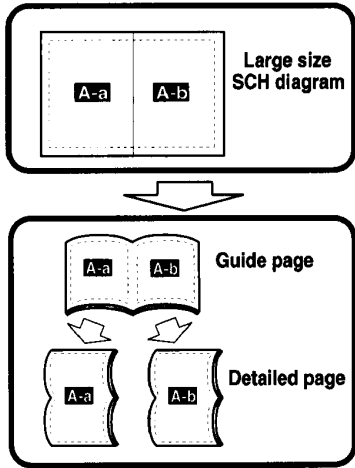

A-b

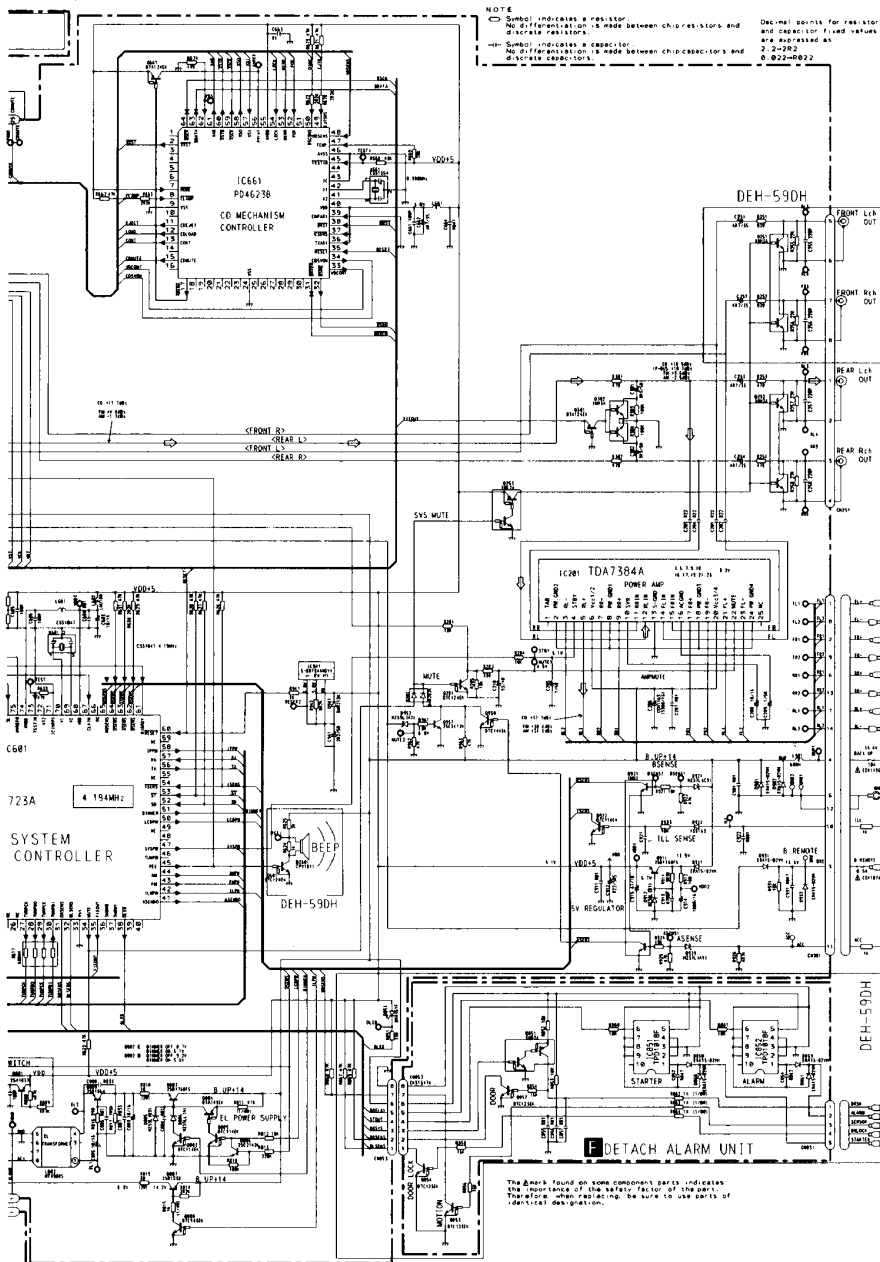
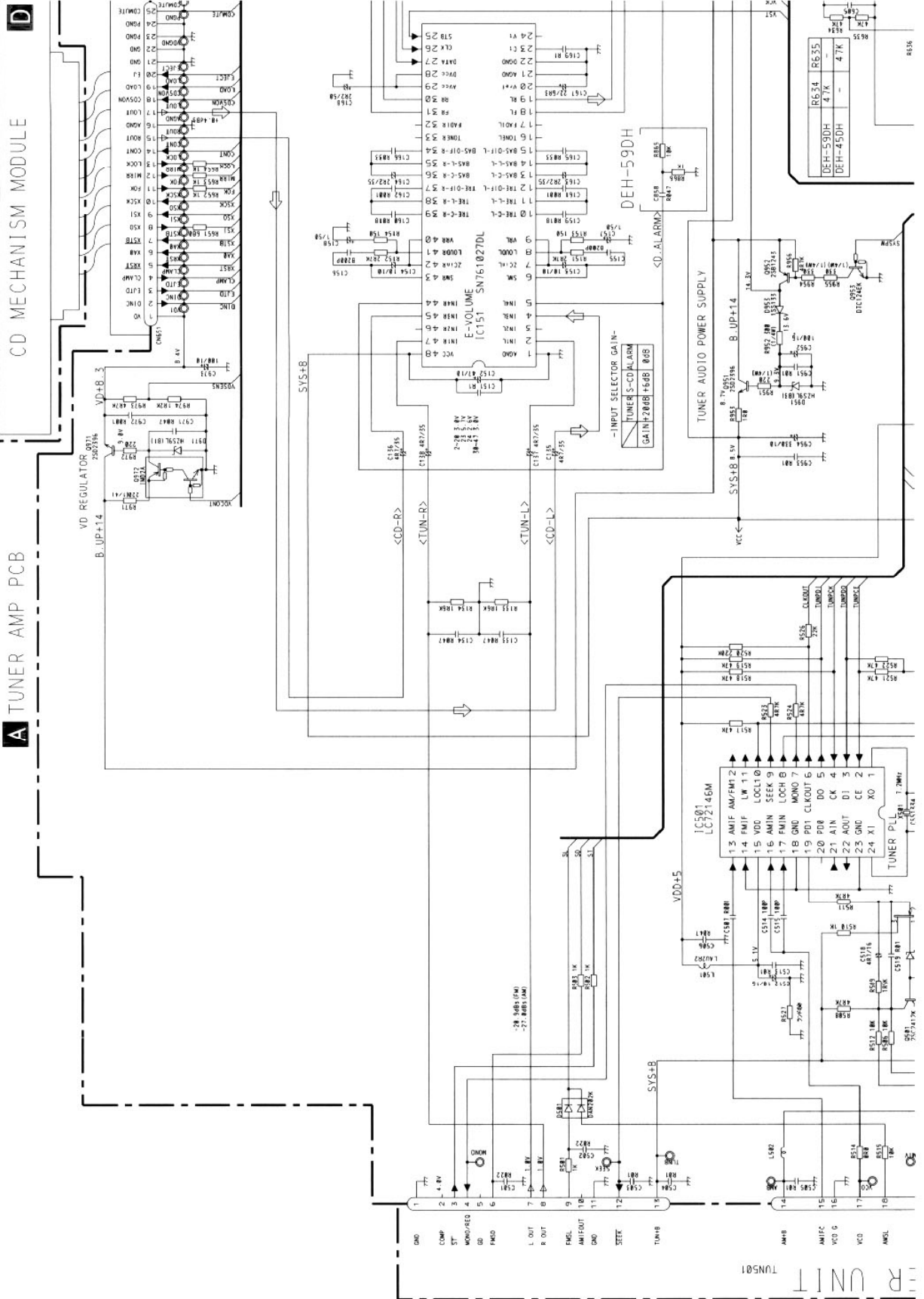

Fig. 7

A-a A-b



TUN501

DEH-59DH,45DH

A-a A-b

NOTE:

- Symbol indicates a resistor.
- Symbol indicates a capacitor.
- No differentiation is made between chip resistors and discrete resistors.
- |— Symbol indicates a capacitor.
- No differentiation is made between chip capacitors and discrete capacitors.

Decimal points for resistor and capacitor fixed values are expressed as:
 2.2-2R2
 0.022-R022

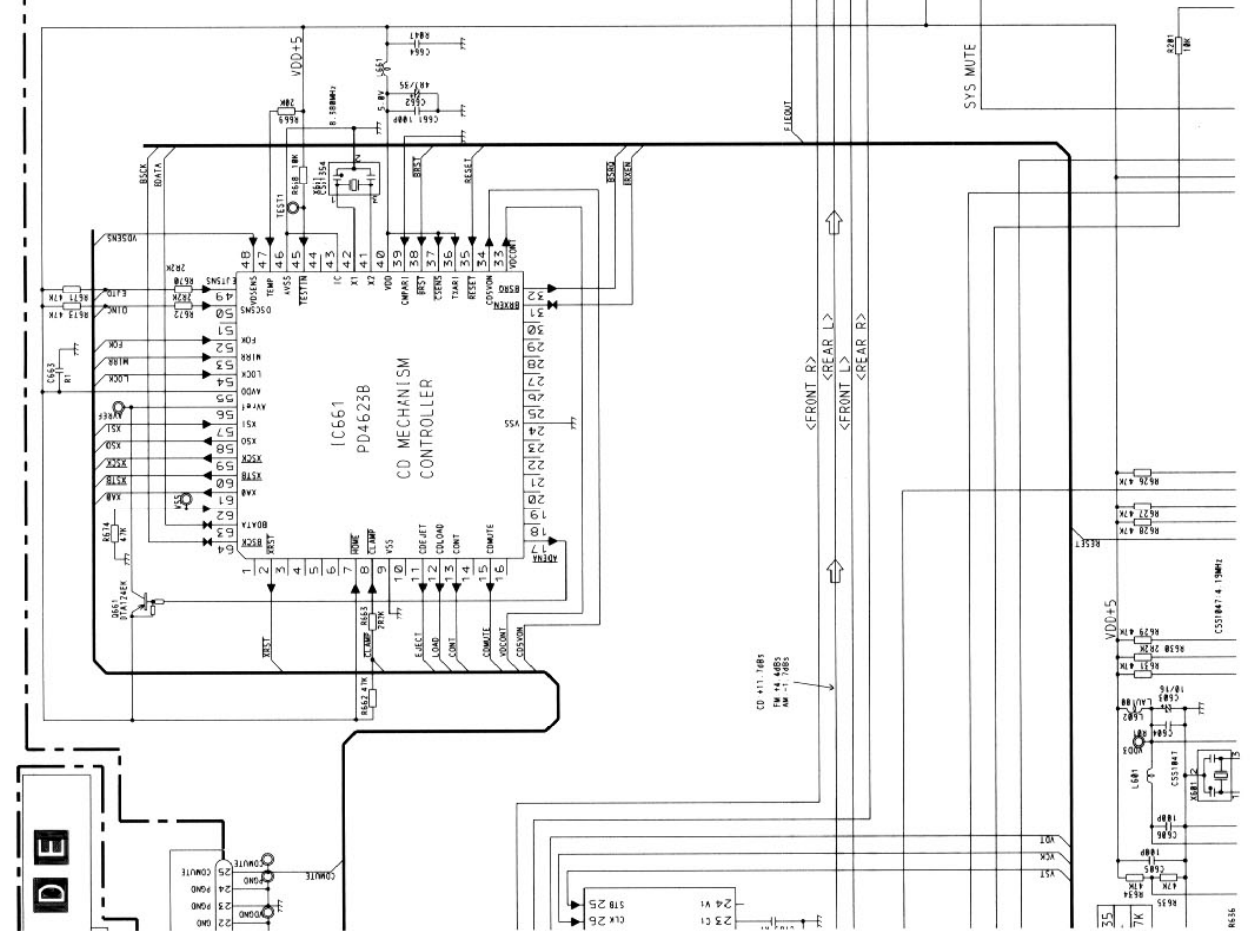

16 A-b

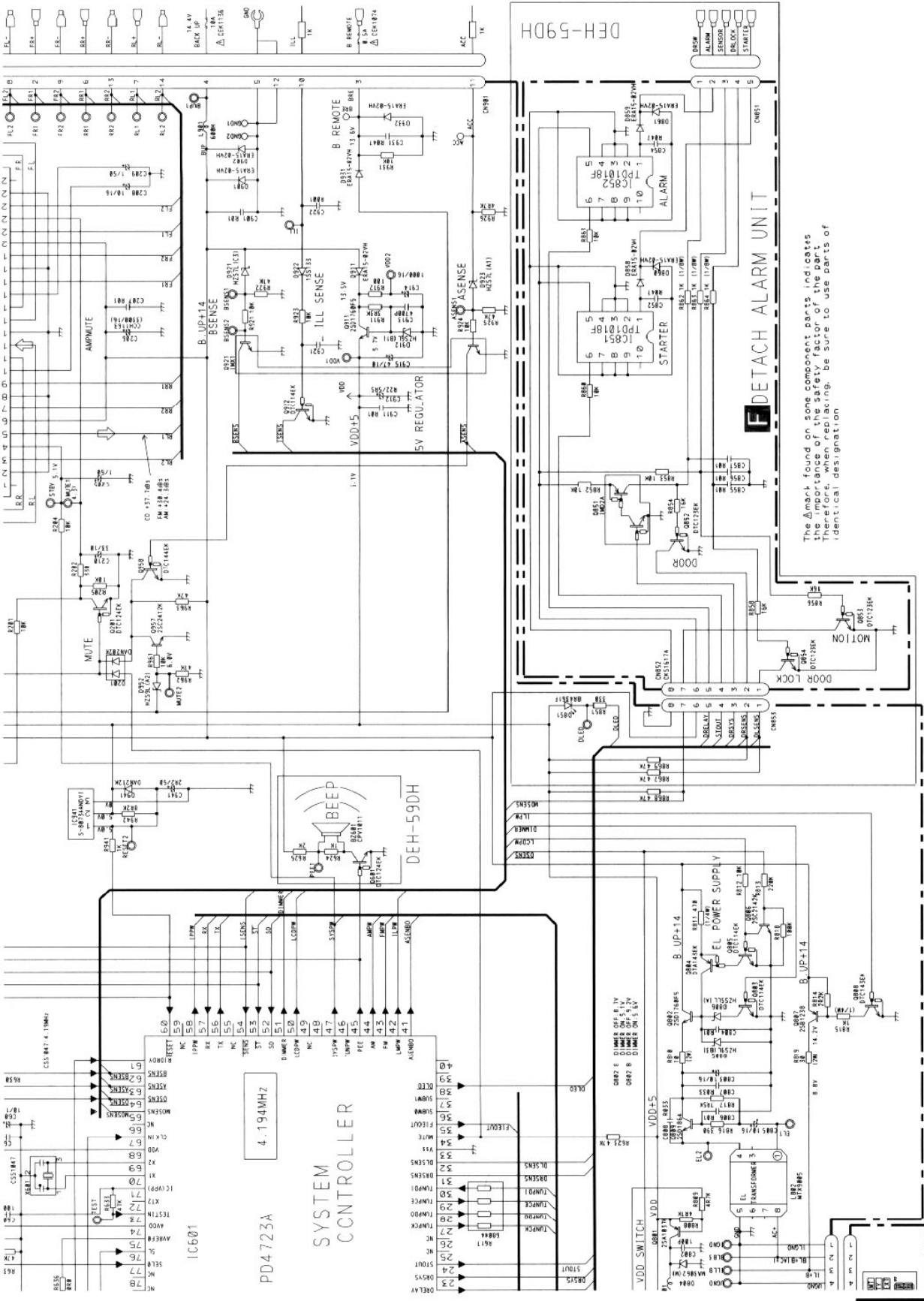

The Δ mark found on some component parts indicates that the part is a substitute part. Therefore, when replacing, be sure to use parts of identical designation.

Aa Ab

Fig. 9

A-b

3.2 CD MECHANISM MODULE(GUIDE PAGE)

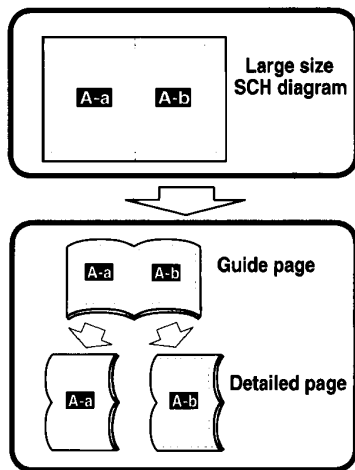

E-a

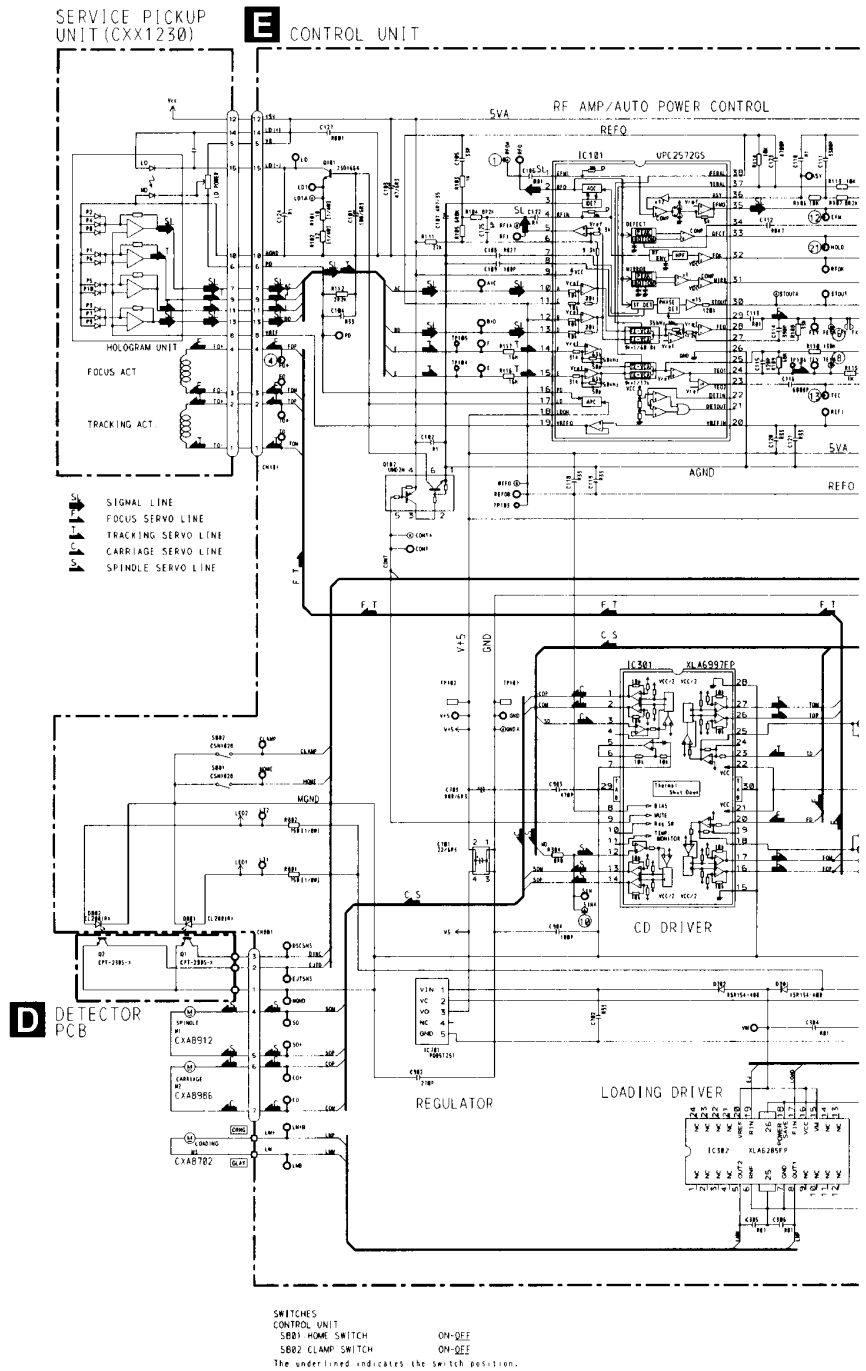

E-b

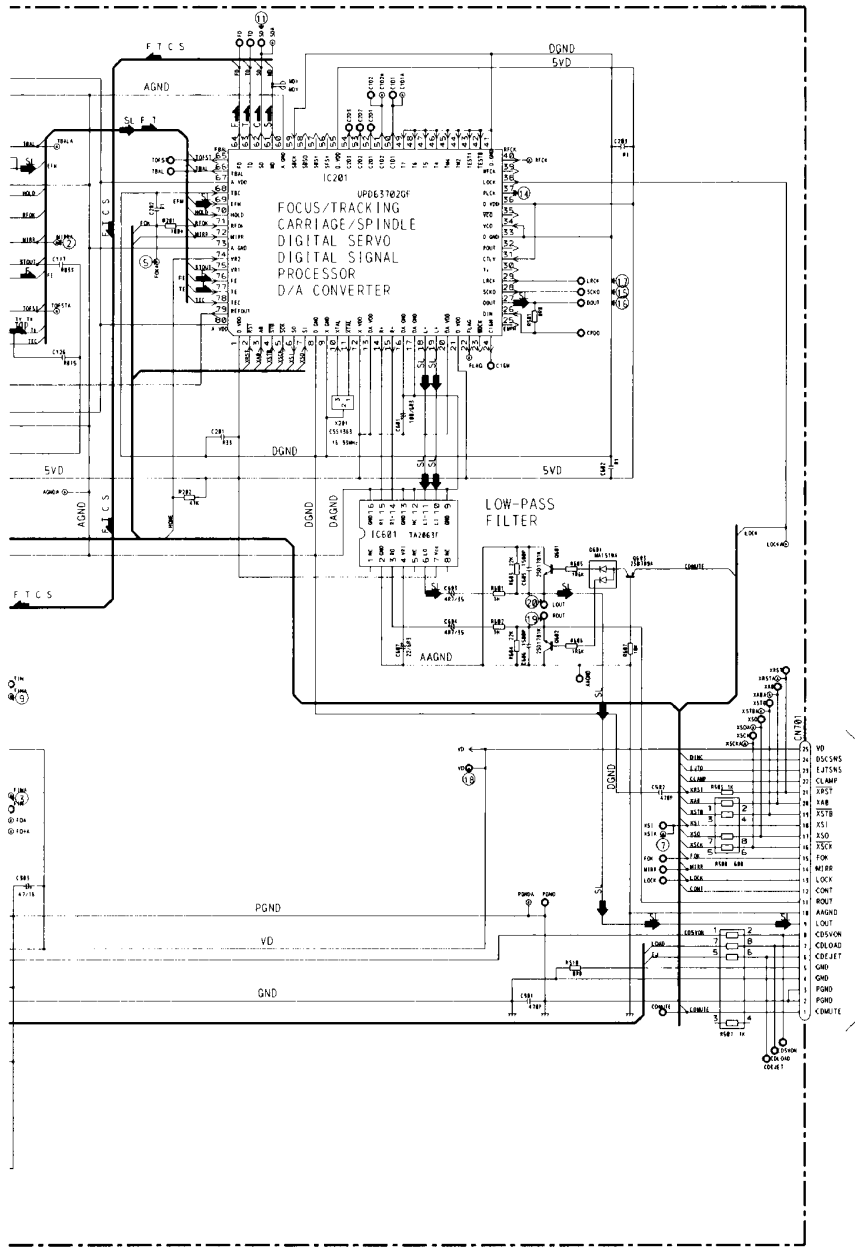
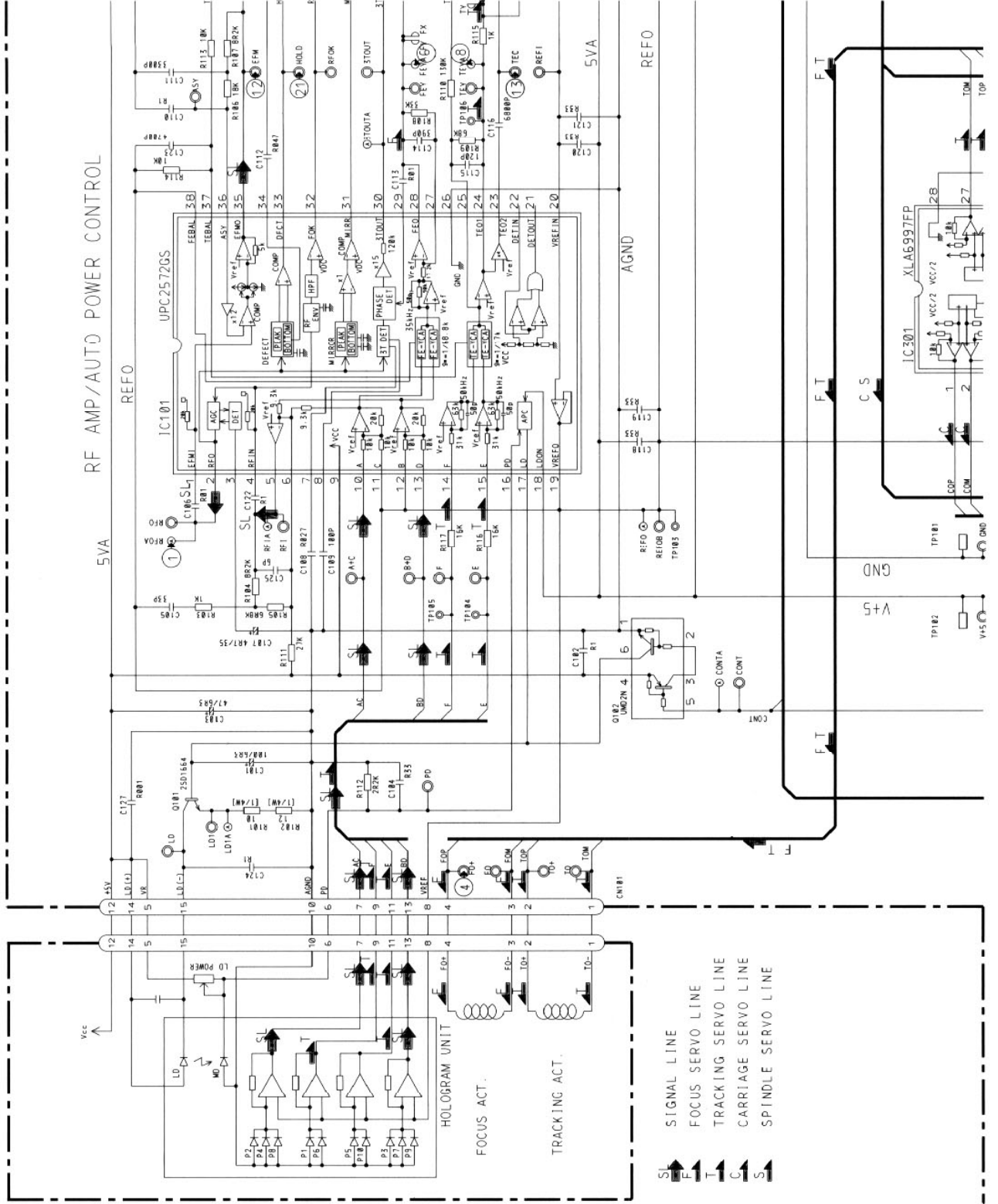

Fig. 10

E-a E-b

E CONTROL UNIT

SERVICE PICKUP UNIT (CXX1230)



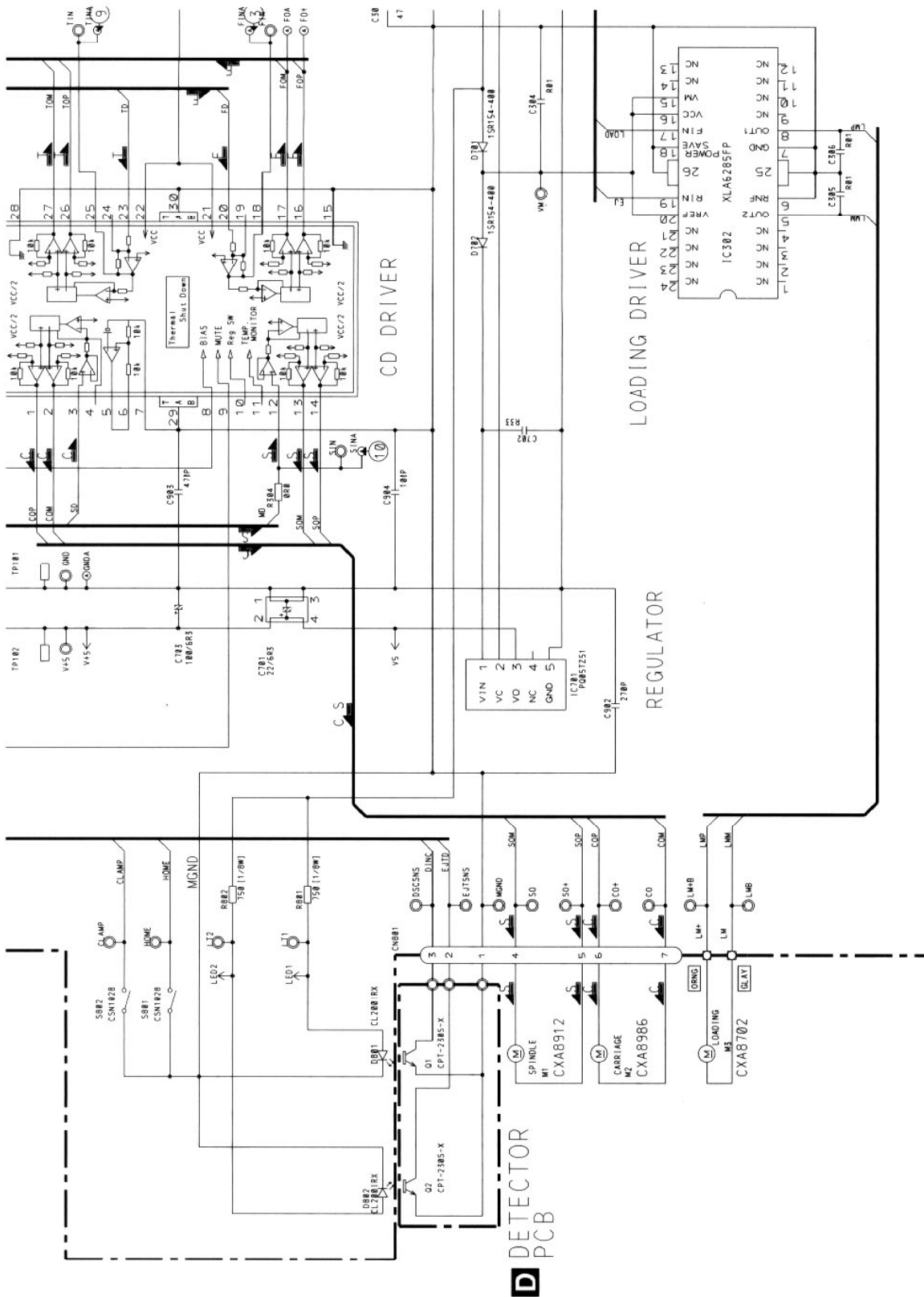

E-a E-b

Fig. 11

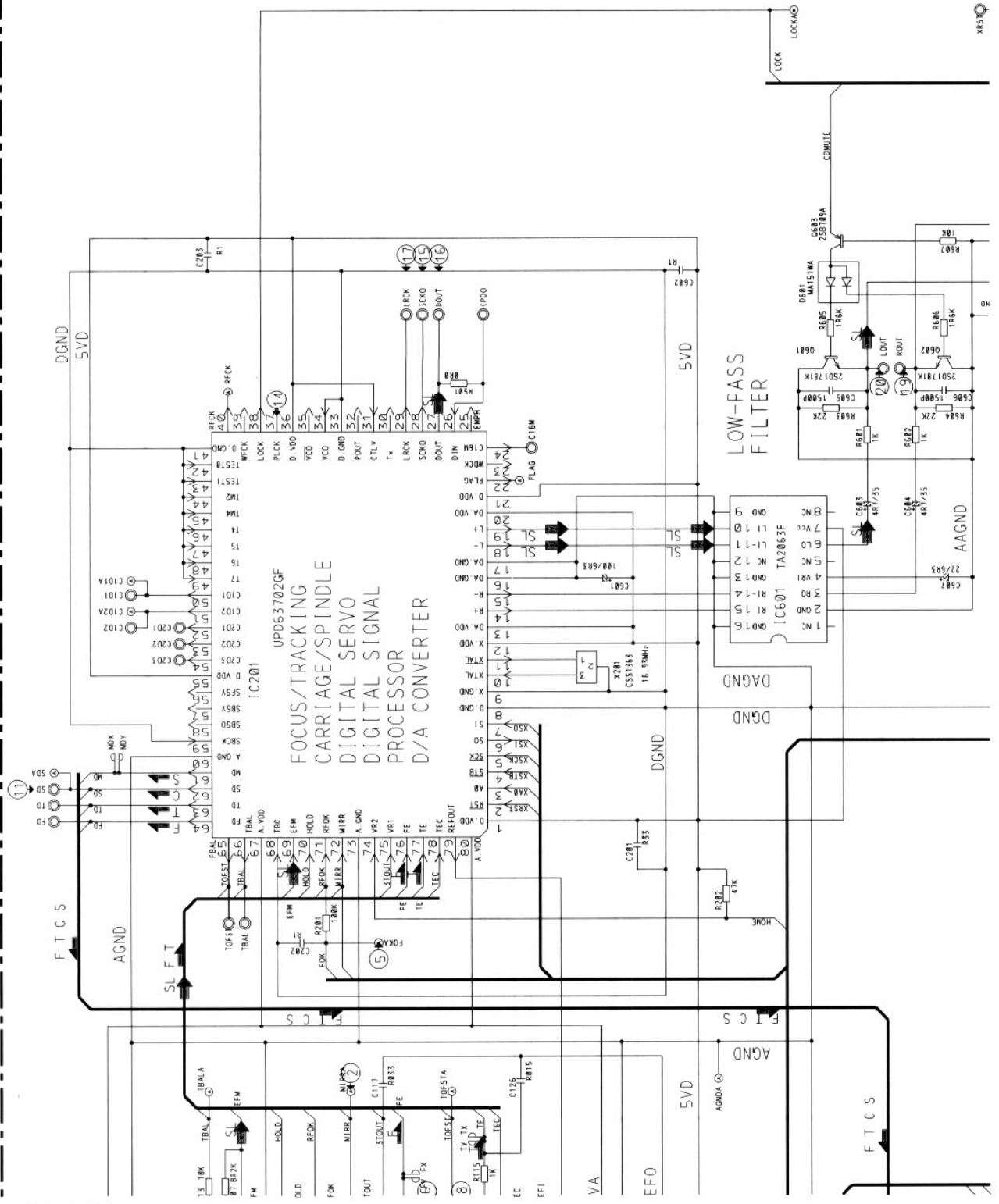

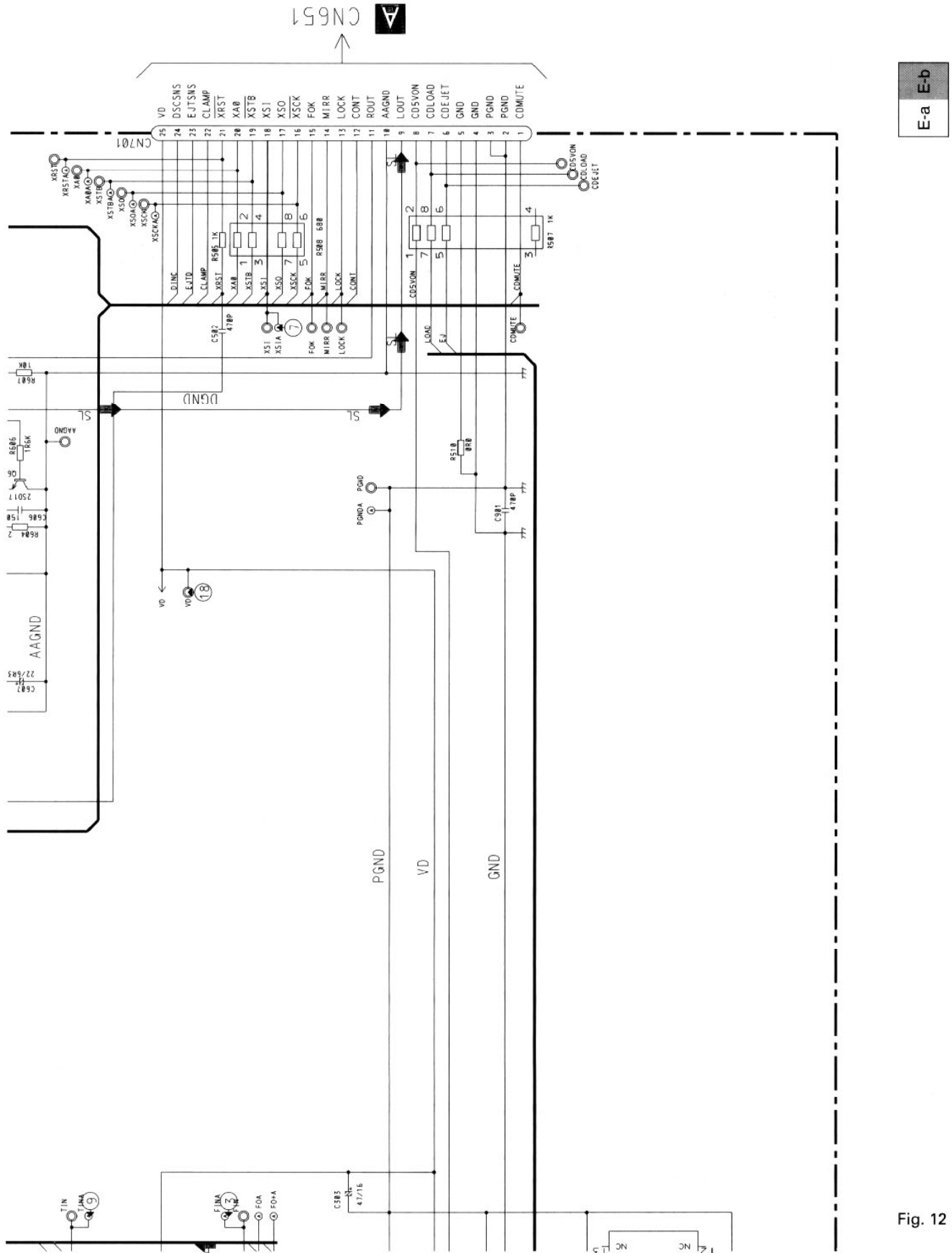

E-a E-b

Fig. 12

E-b

DEH-59DH,45DH

Note:1. The encircled numbers denote measuring pointes in the circuit diagram.
 2. Reference voltage
 REFO:2.5V

● Waveforms

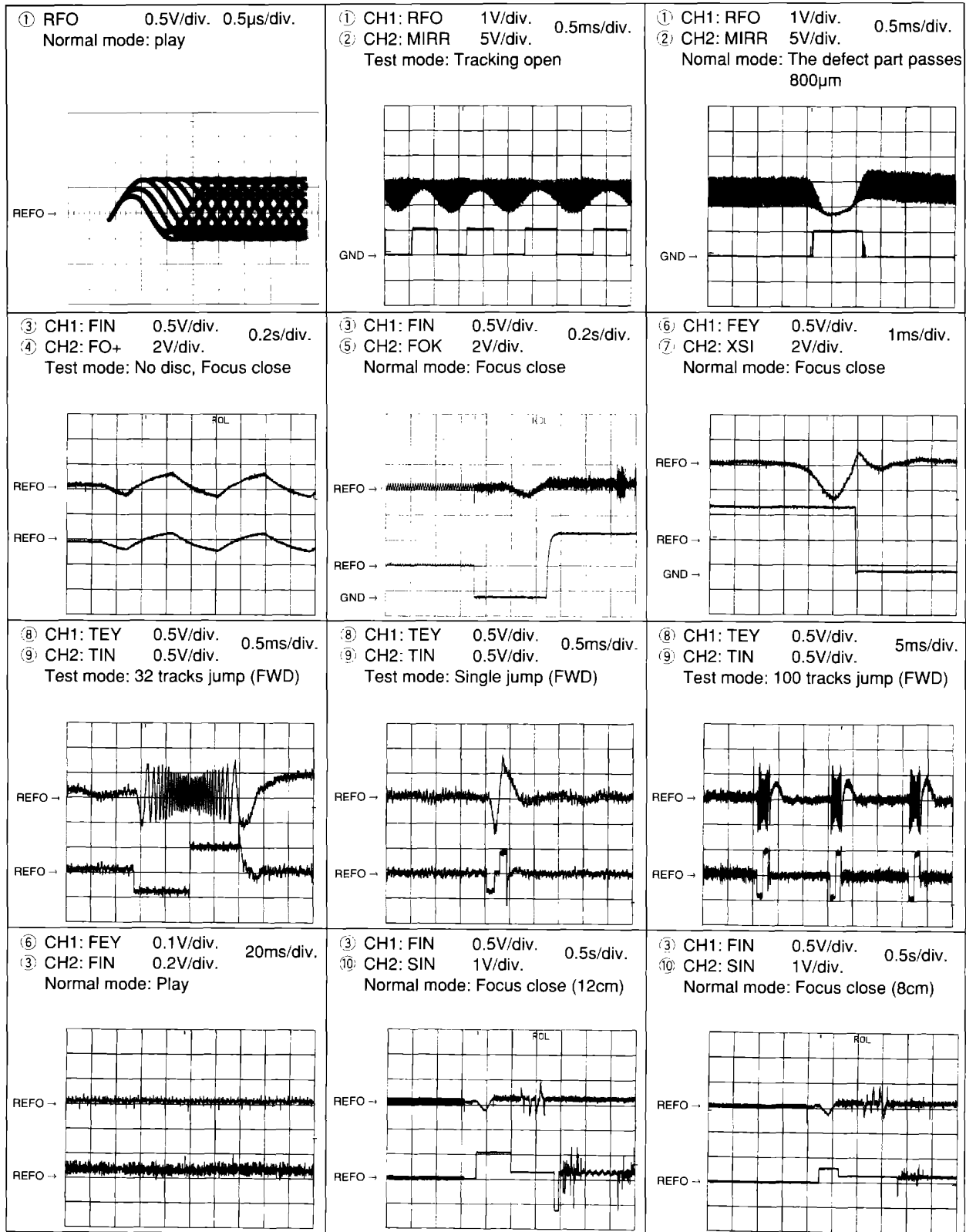

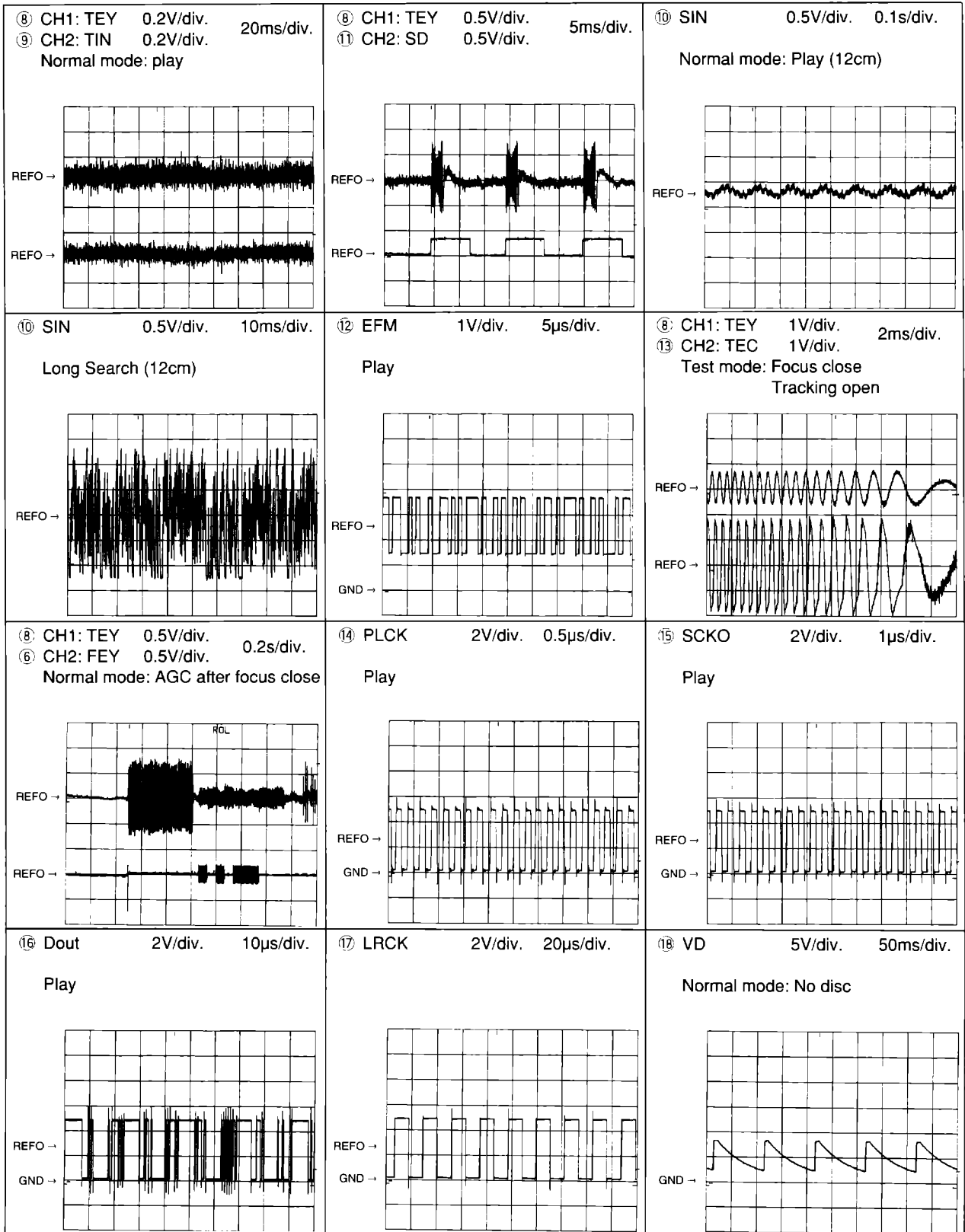

DEH-59DH,45DH

⑱ CH1: R OUT 1V/div. 0.2ms/div.
 ⑳ CH2: L OUT 1V/div. 0.2ms/div.
 Normal mode: Play (1kHz 0dB)

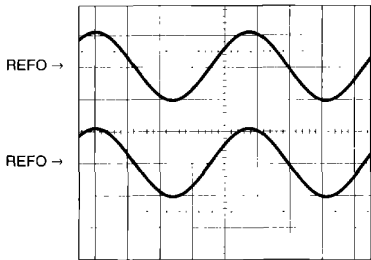

⑥ CH1: FEY 0.2V/div. 1ms/div.
 ③ CH2: FIN 0.5V/div. 1ms/div.
 Normal mode: During AGC

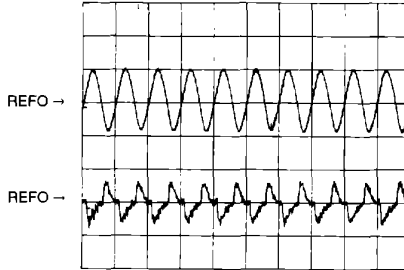

⑧ CH1: TEY 0.2V/div. 1ms/div.
 ⑨ CH2: TIN 0.5V/div. 1ms/div.
 Normal mode: During AGC

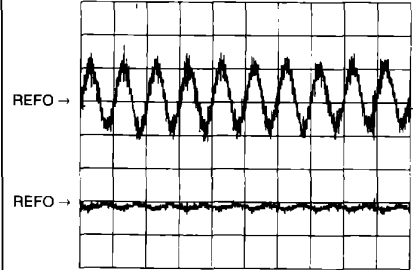

① CH1: RFO 1V/div. 0.5ms/div.
 ⑰ CH2: HOLD 5V/div. 0.5ms/div.
 Normal mode: The defect part passes
 800μm

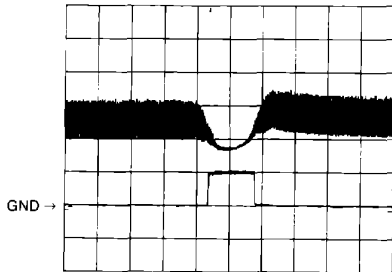

③ CH1: FIN 1V/div. 0.5ms/div.
 ⑲ CH2: HOLD 5V/div. 0.5ms/div.
 Normal mode: The defect part passes
 800μm

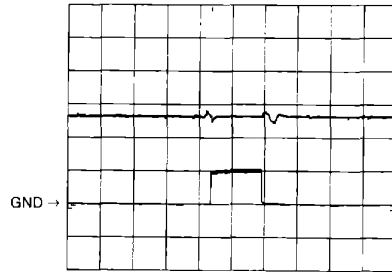

3.3 FM/AM TUNER UNIT

A

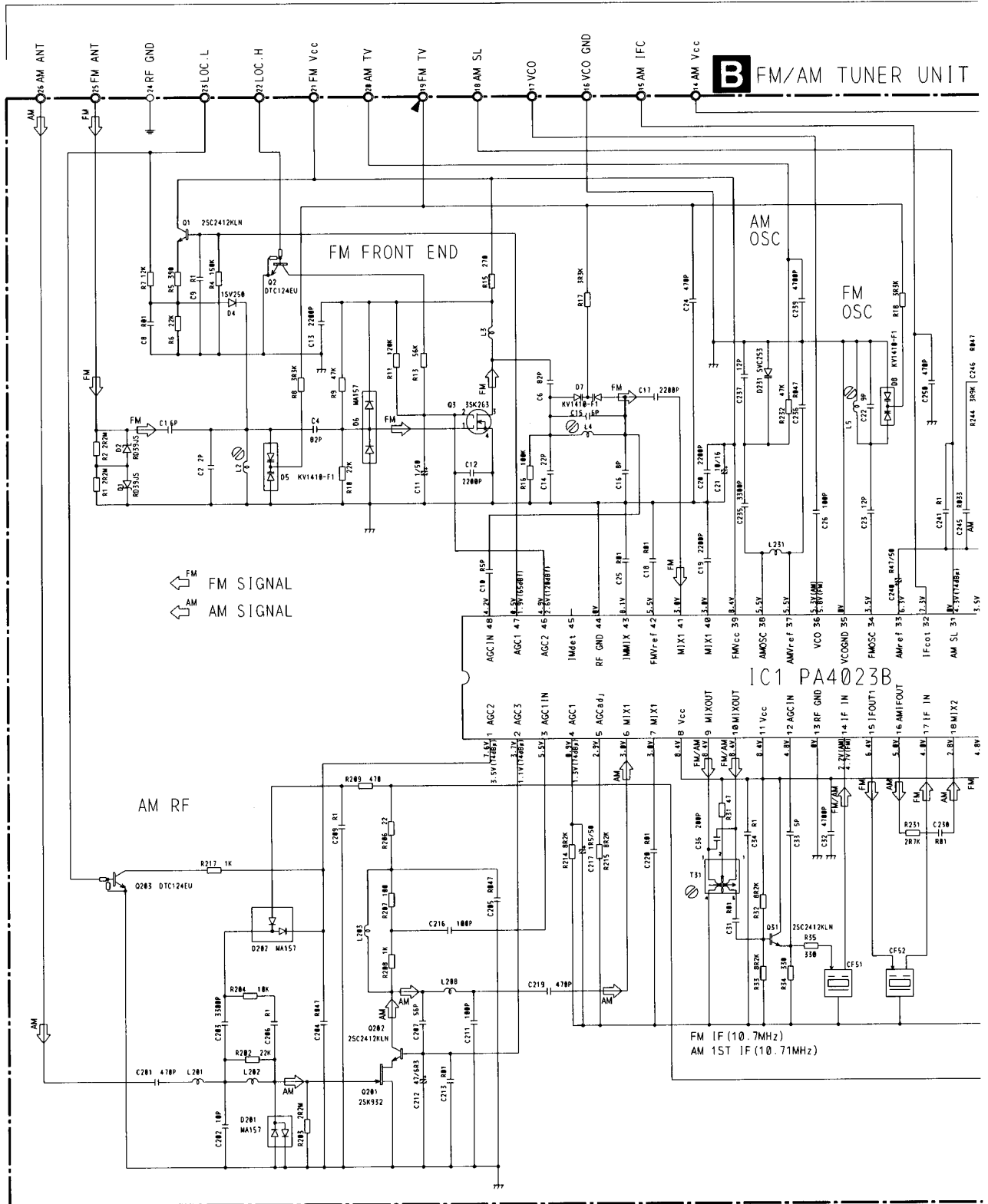

B FM/AM TUNER UNIT

B

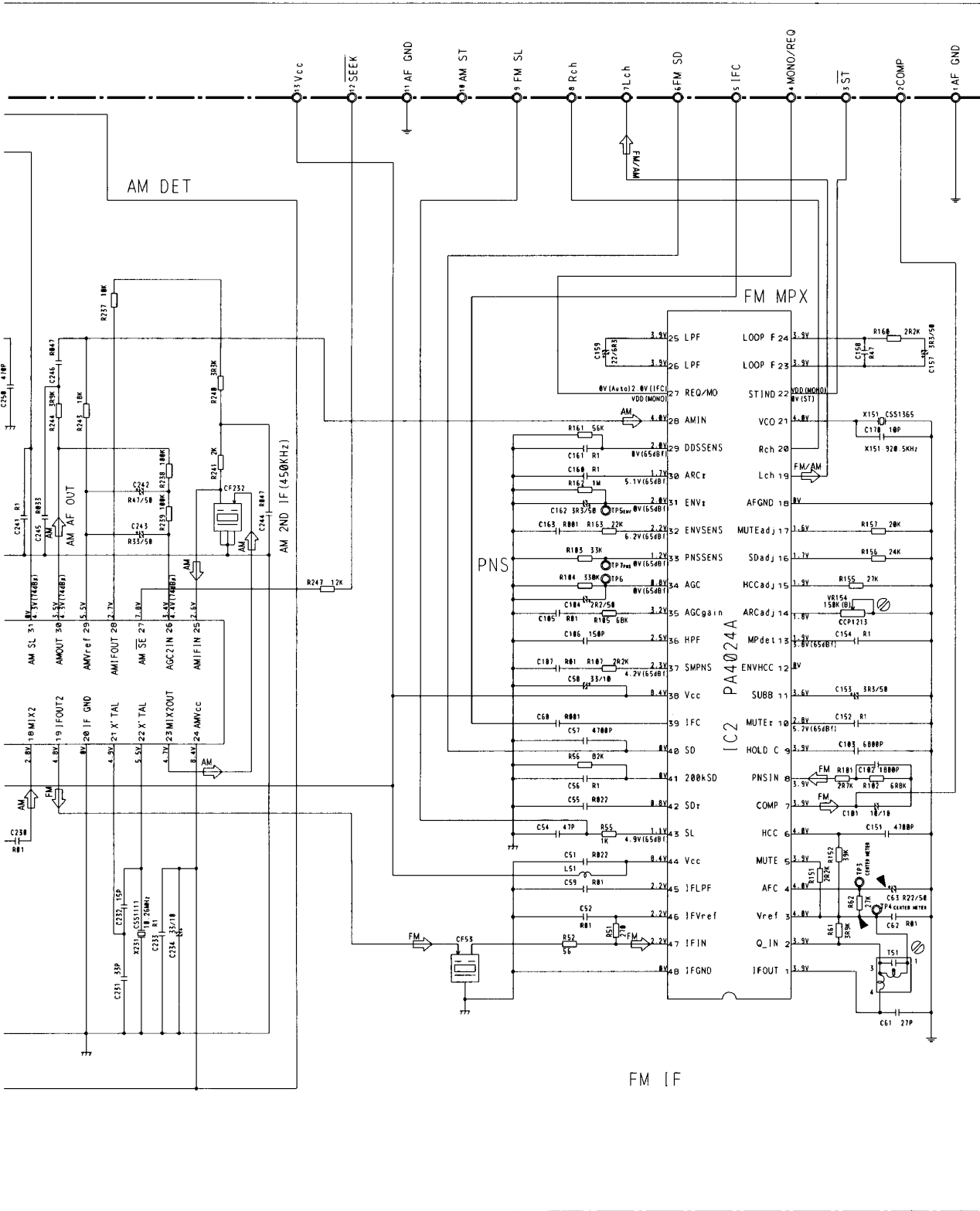
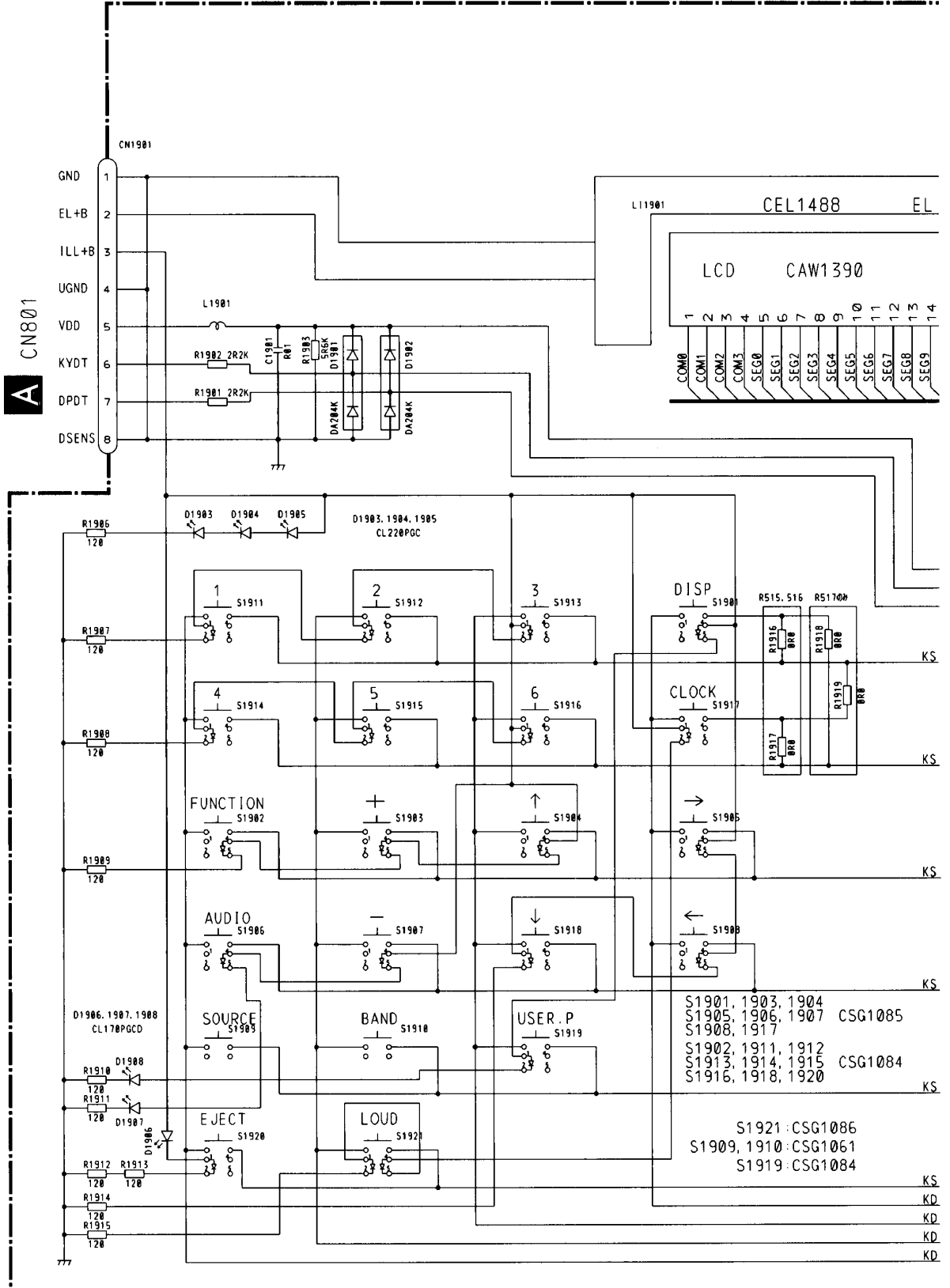

Fig. 13



3.4 KEYBOARD UNIT



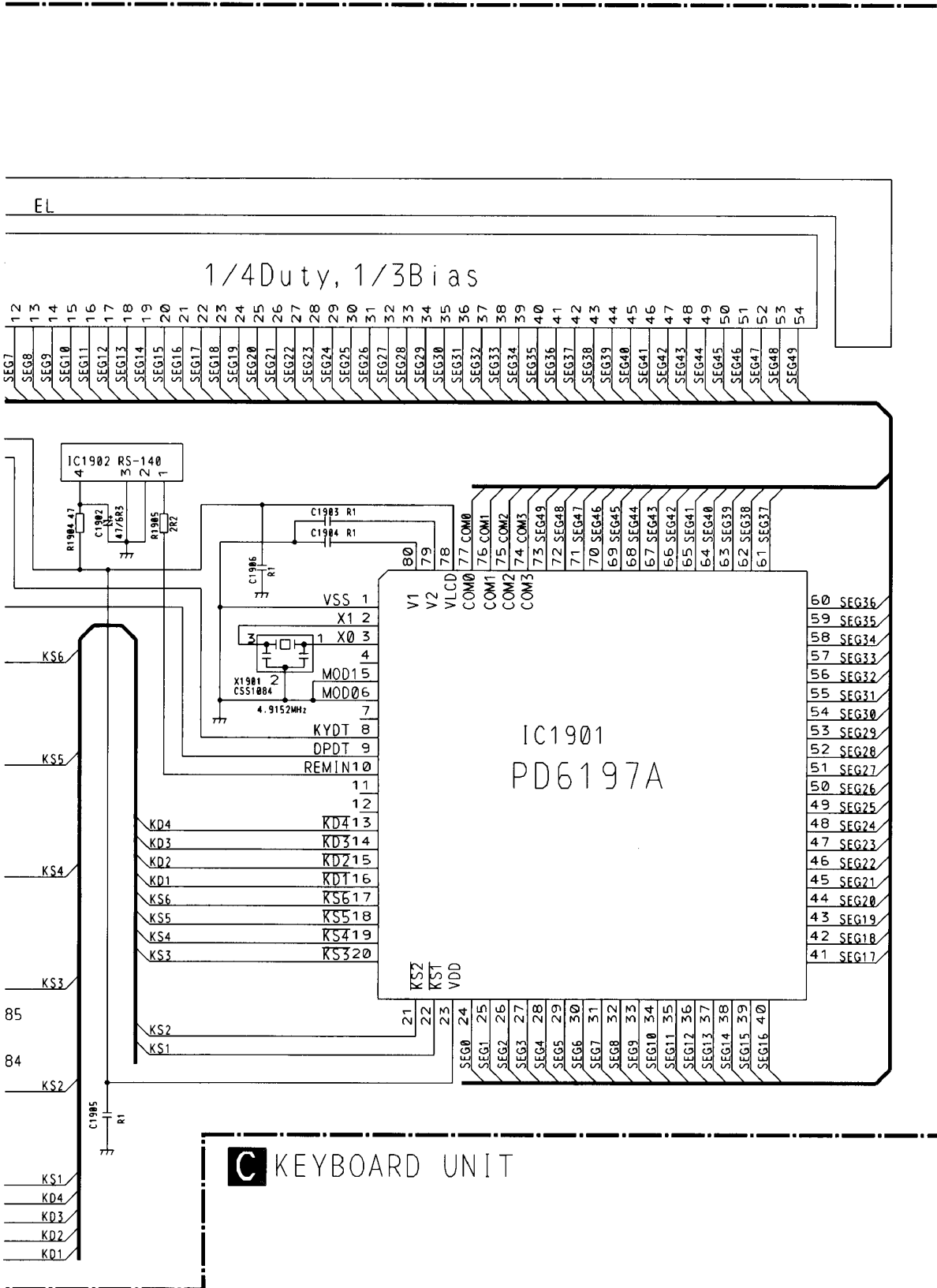

Fig. 14

4. PCB CONNECTION DIAGRAM

4.1 TUNER AMP PCB

NOTE FOR PCB DIAGRAMS

1. The parts mounted on this PCB include all necessary parts for several destination. For further information for respective destinations, be sure to check with the schematic diagram.
2. Viewpoint of PCB diagrams

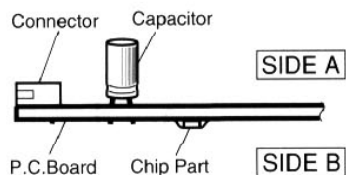

A IC. 0

- IC271
- IC101 0101
- IC272
- IC102
- 0952 0102
- 0951 0956 0503
- 0955
- 0251 0252
- IC201
- 0021 0502
- 0954
- 0302
- 0911 IC151
- 0301
- IC601
- 0802
- IC701
- IC751
- IC661
- 0800 0972
- 0801 IC941
- 0807 0971

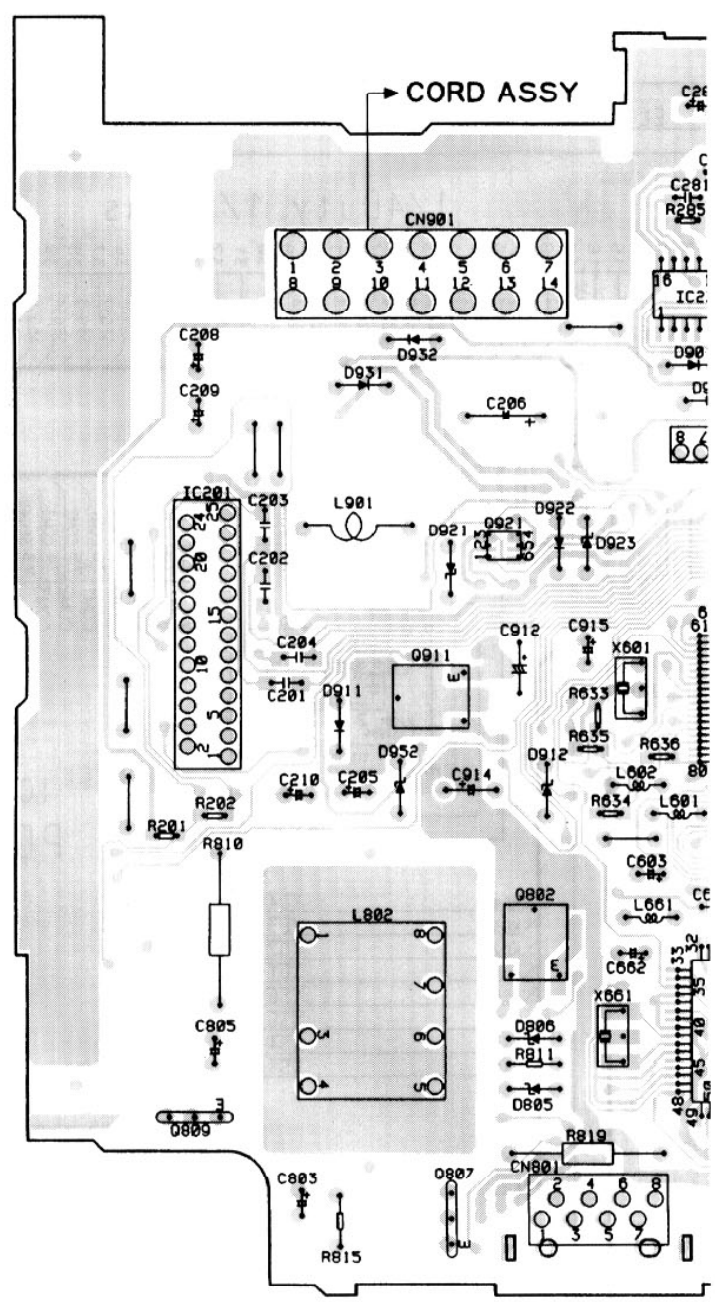

SIDE A

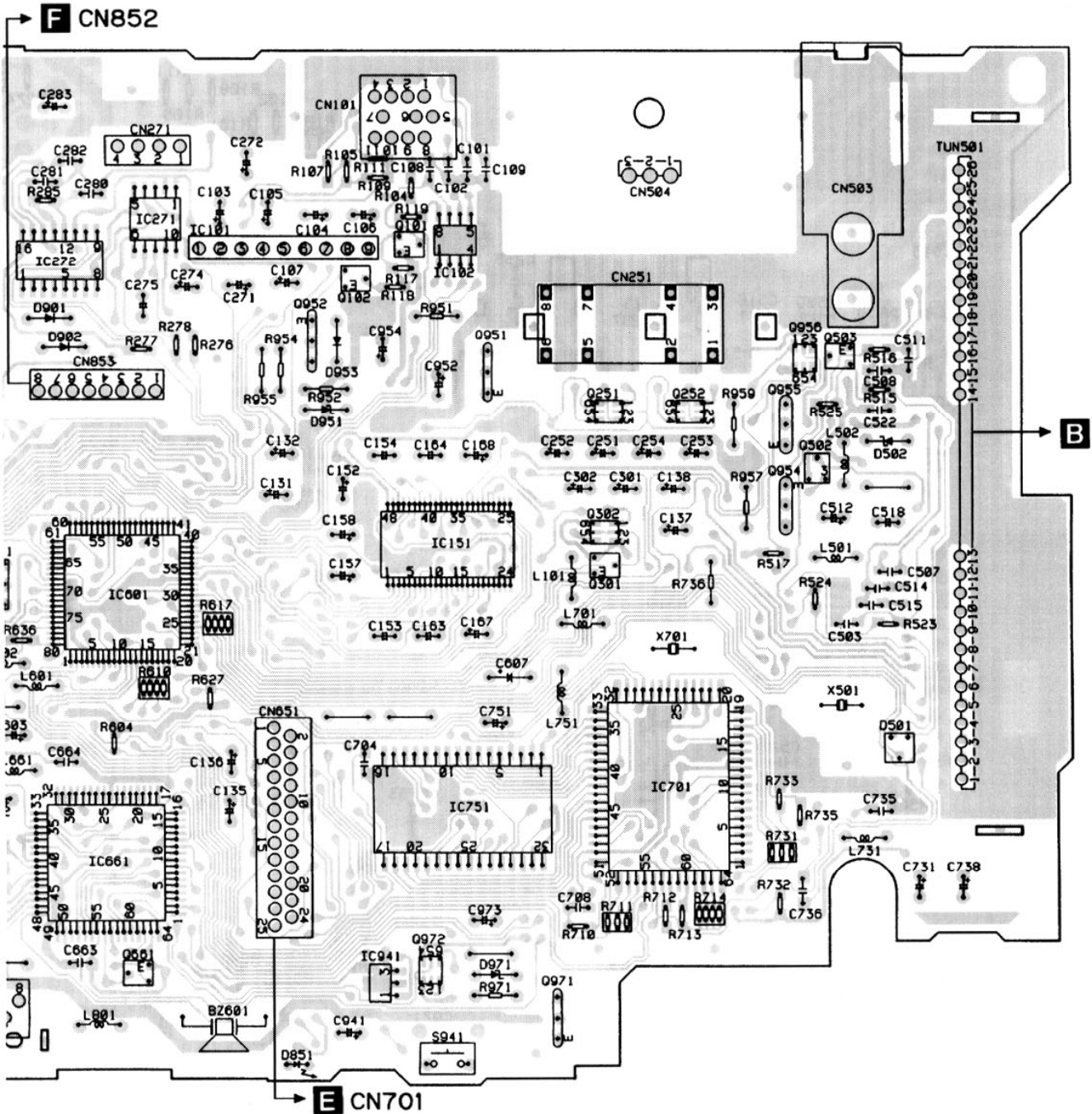
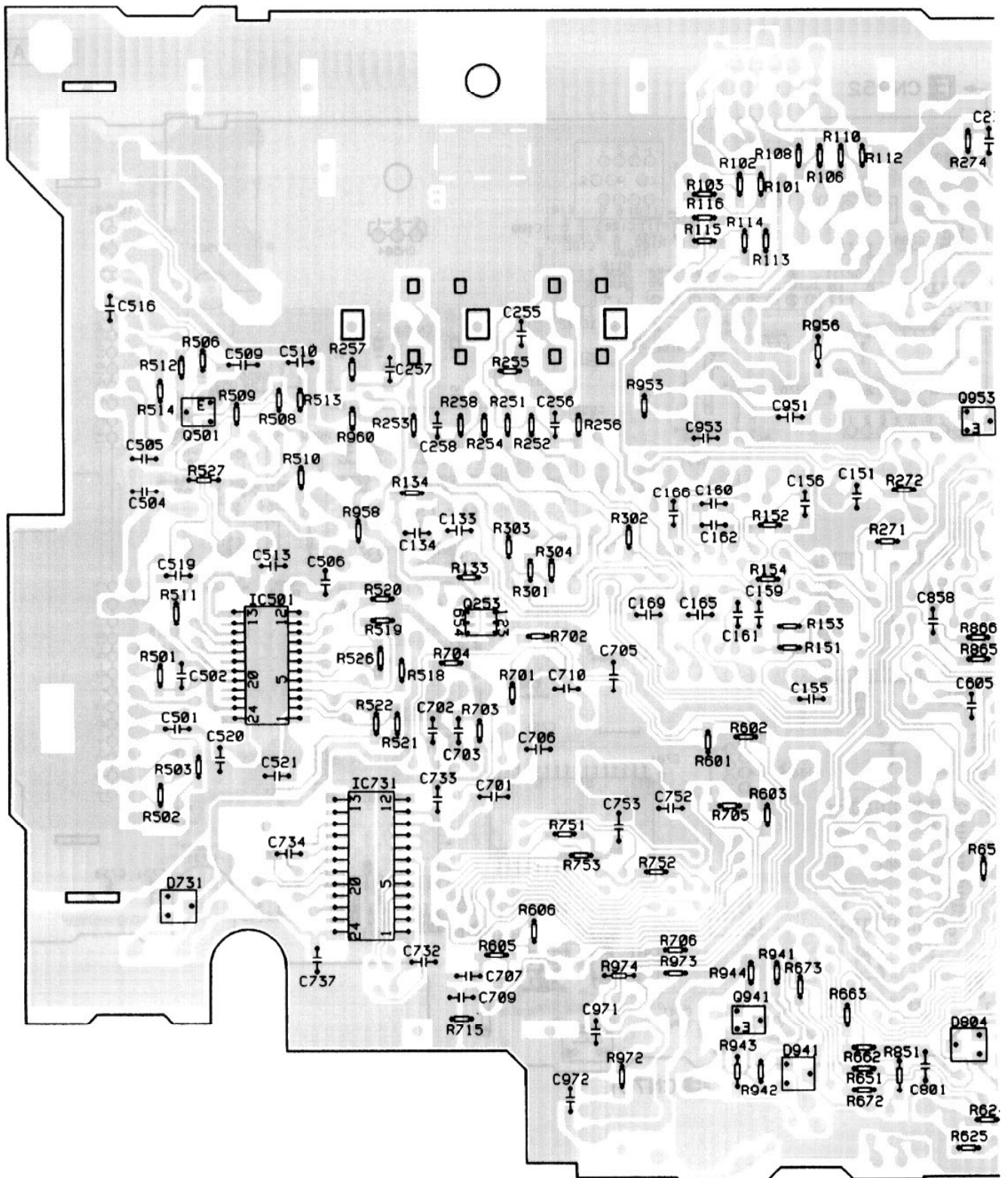

Fig. 15

A

A



A

SIDE B

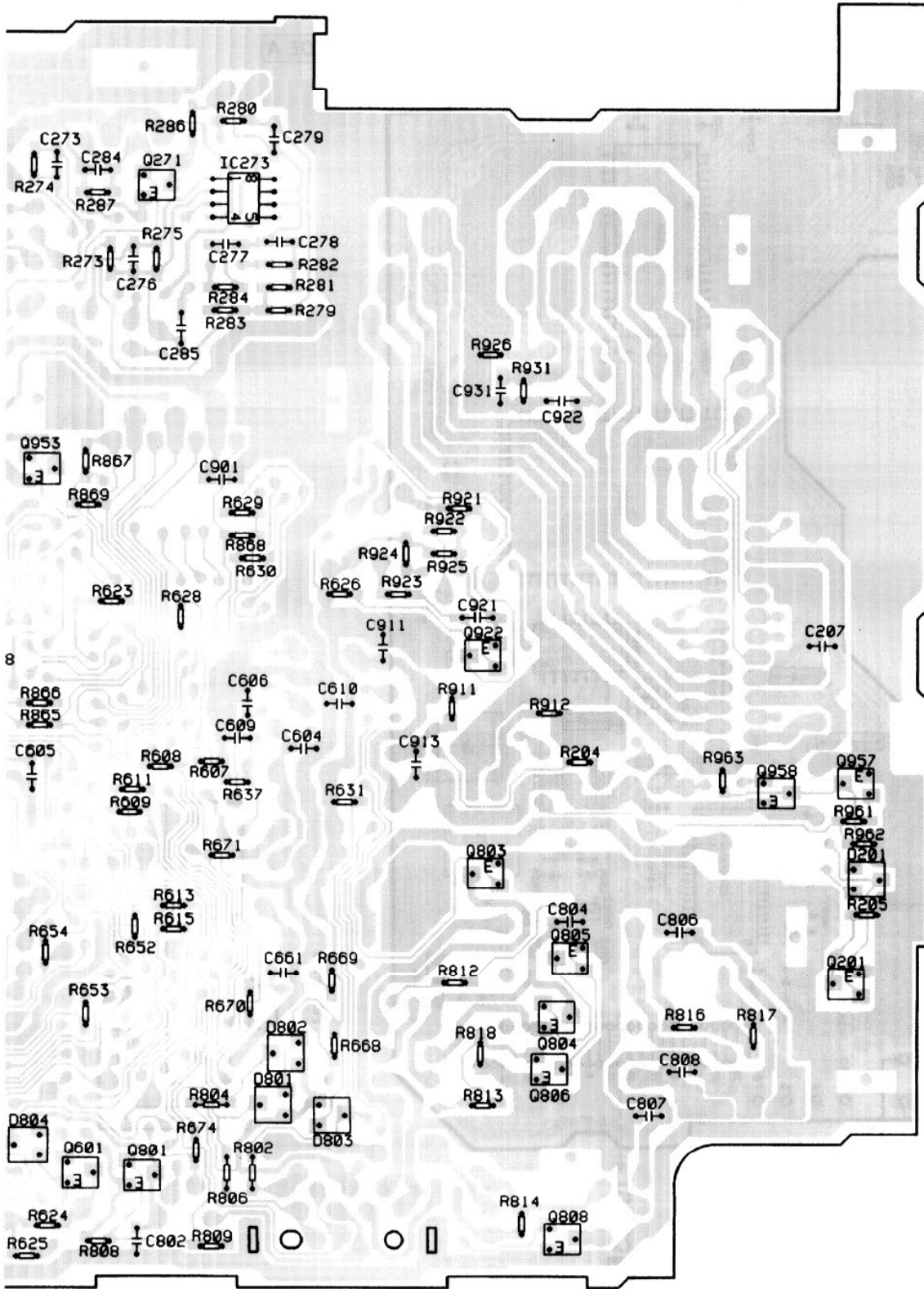

- IC. 0
- Q271
- Q953
- Q501
- Q922
- IC501
- Q253
- Q958
- Q957
- Q803
- IC731
- Q805
- Q201
- Q804
- Q941
- Q806
- Q601
- Q801
- Q808

Fig. 16

4.2 CONTROL UNIT, DETECTOR PCB

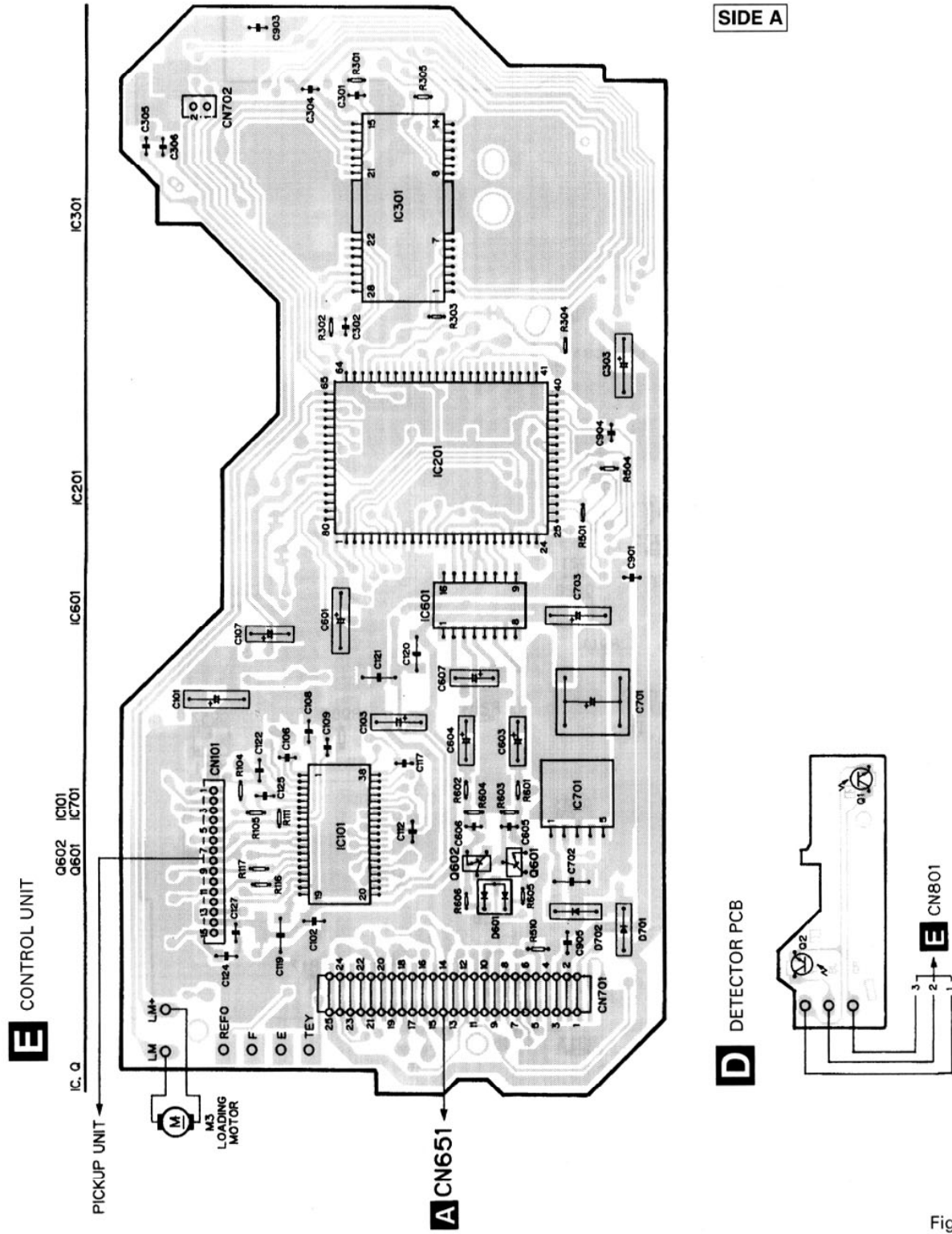

SIDE A

D DETECTOR PCB

E CONTROL UNIT

A CN651

Fig. 17

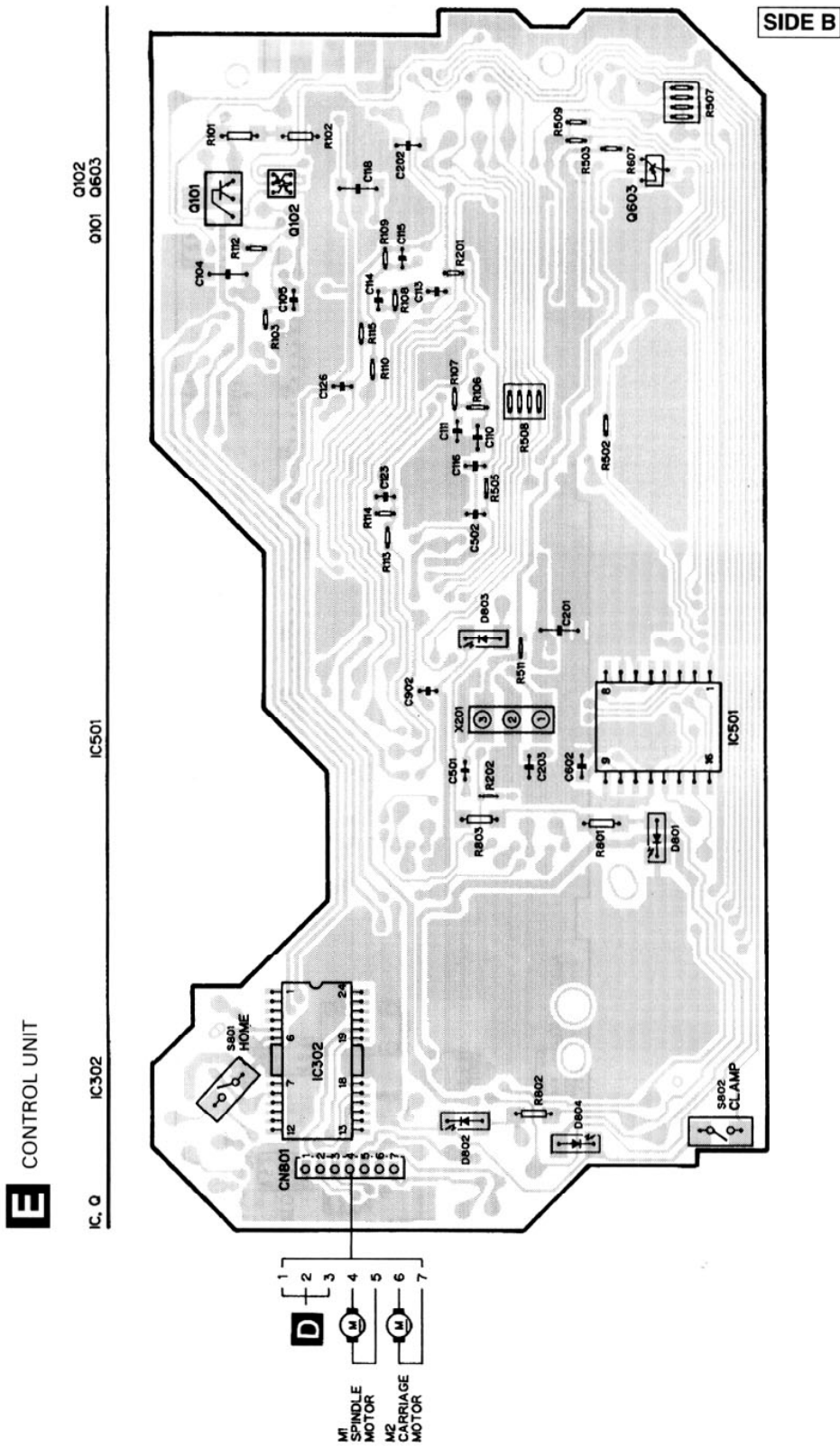

Fig. 18



4.3 KEYBOARD UNIT

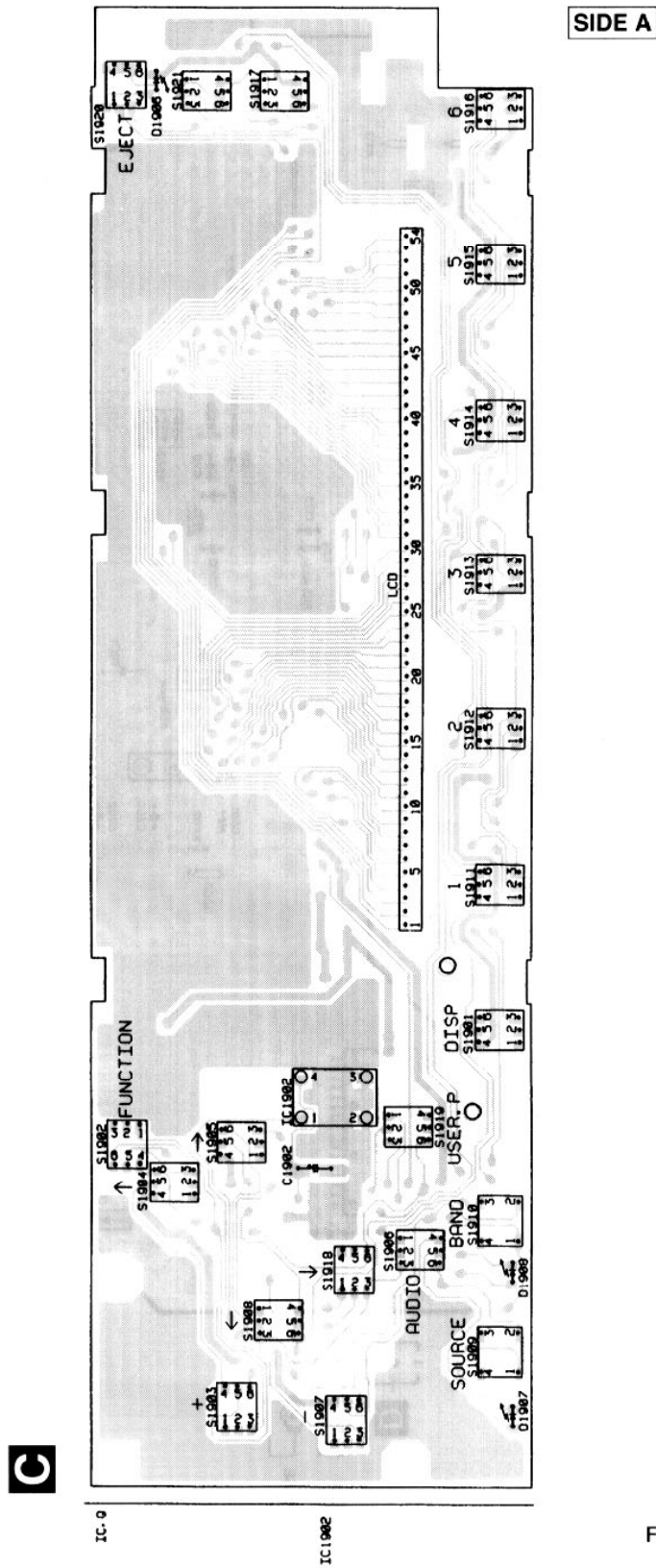

Fig. 19



SIDE B

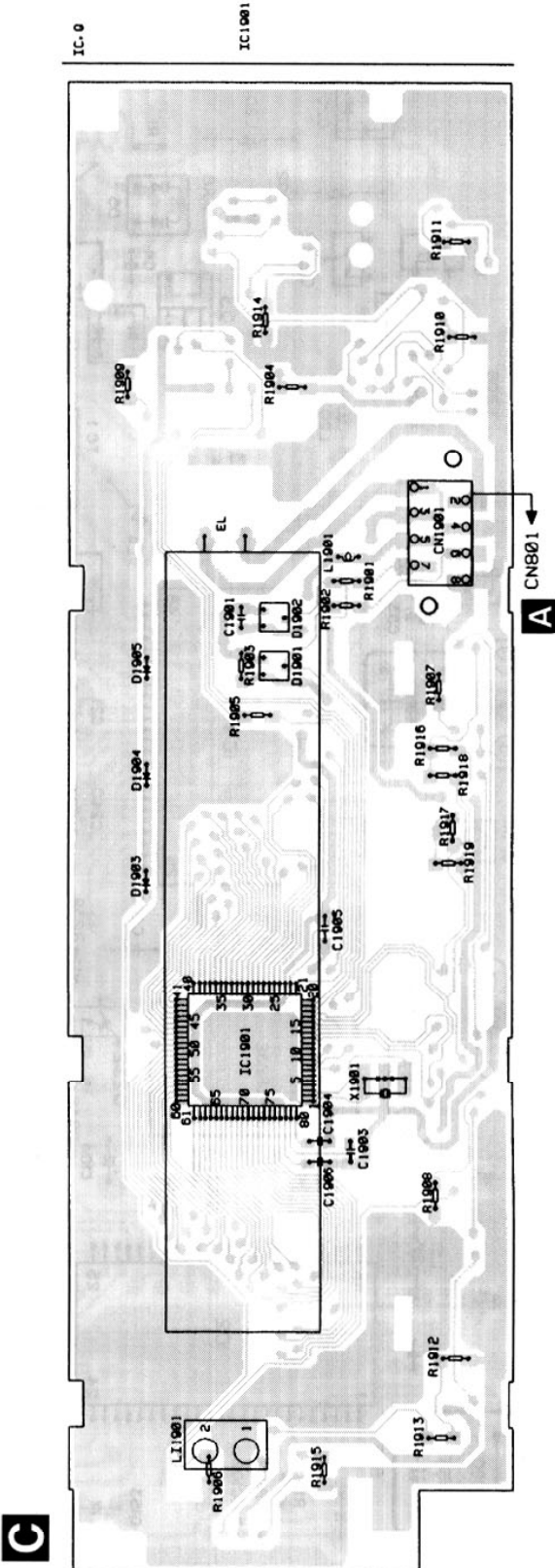

Fig. 20

4.4 FM/AM TUNER UNIT

SIDE A

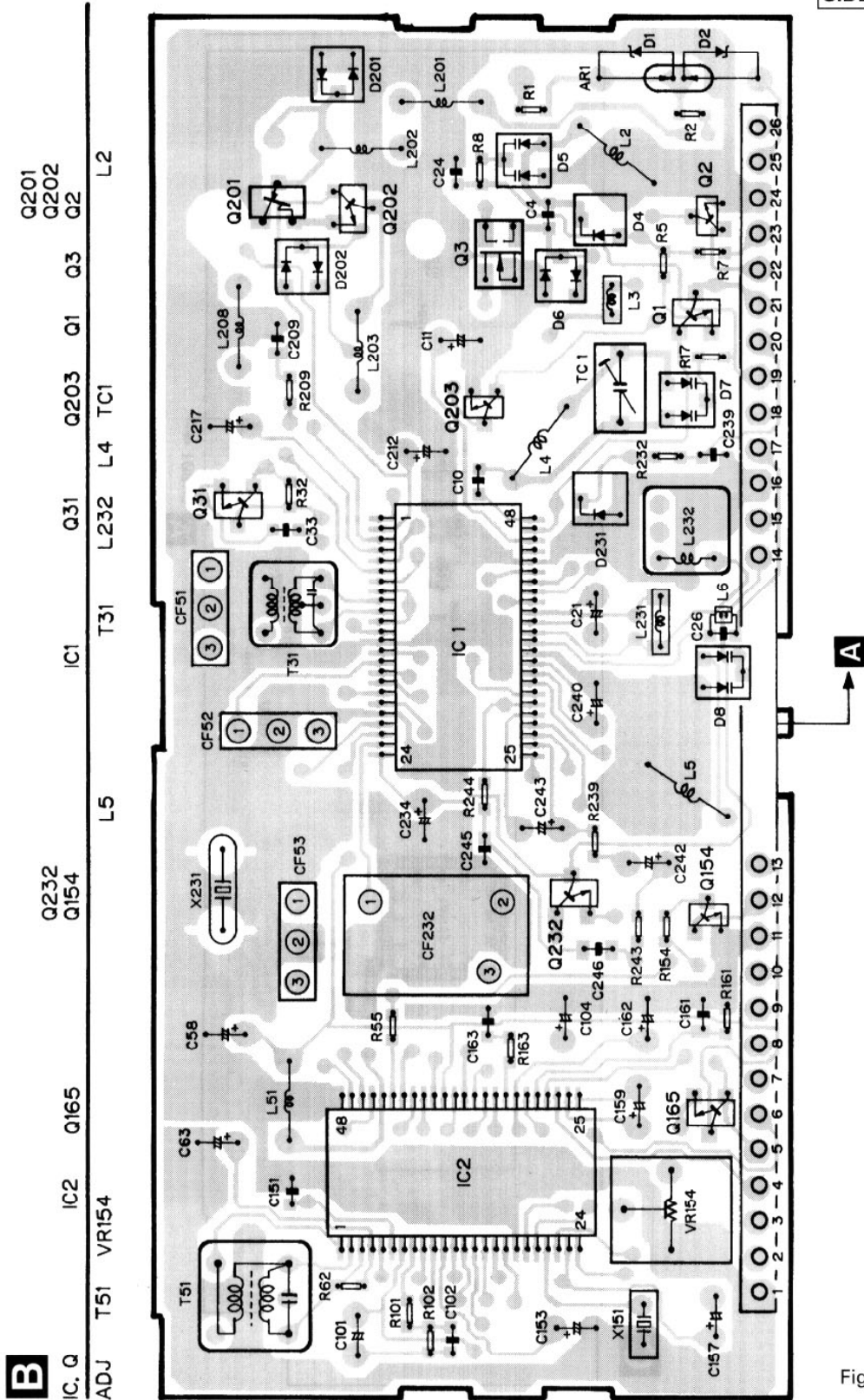

Fig. 21



SIDE B

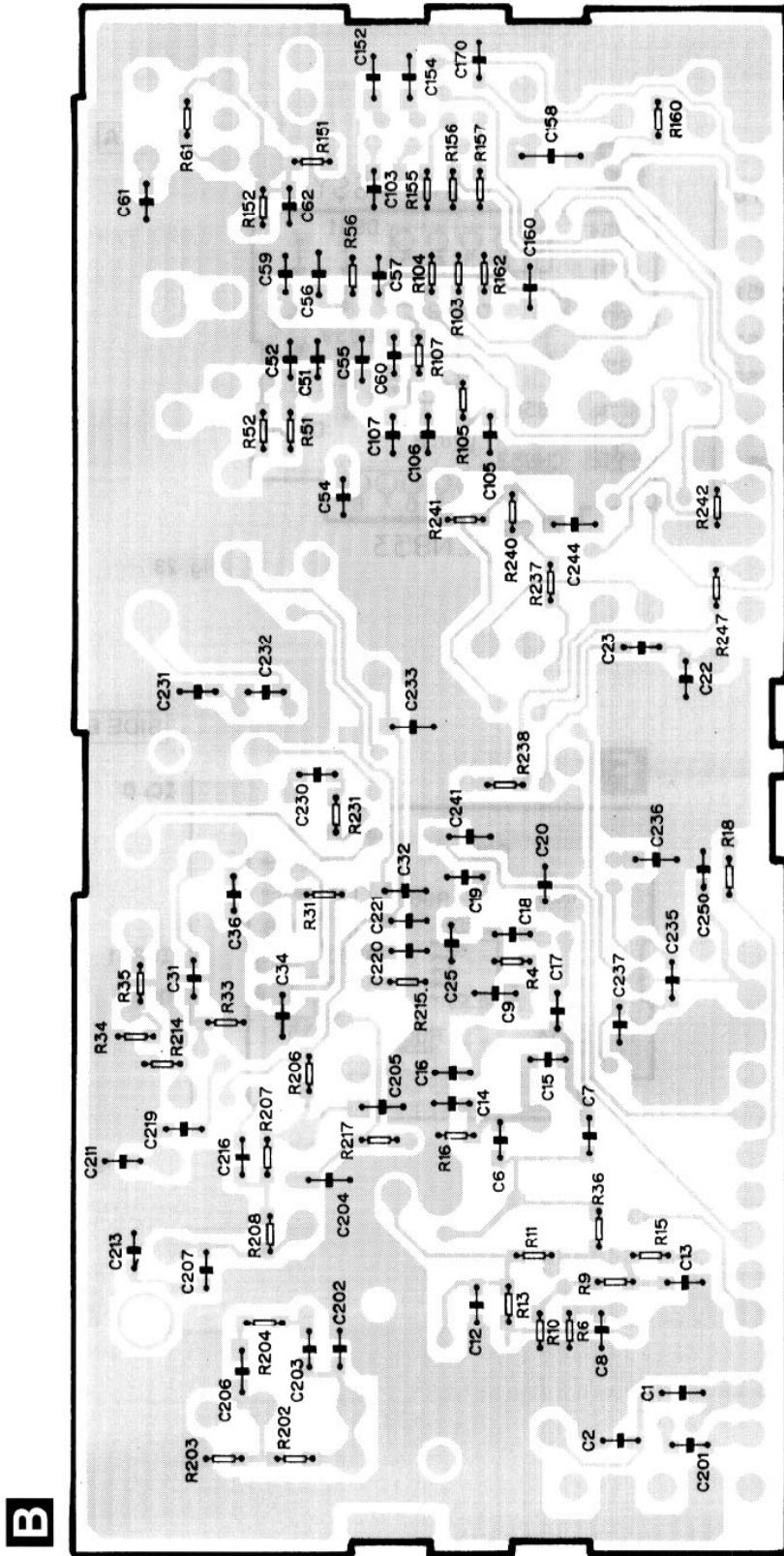

Fig. 22

B

DEH-59DH,45DH

4.5 DETACH ALARM UNIT(DEH-59DH)

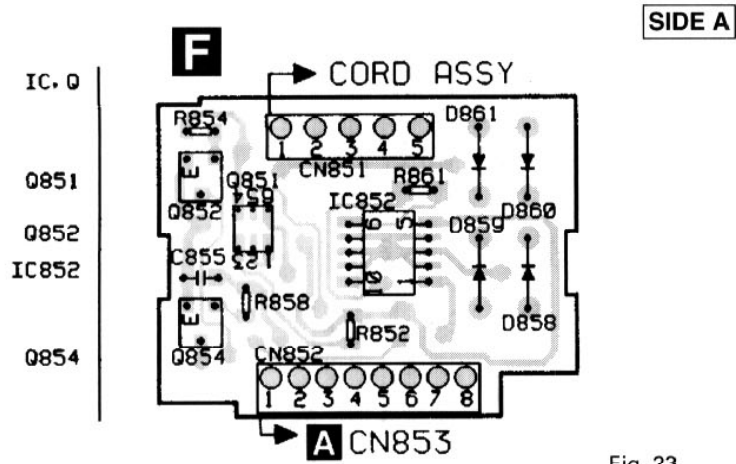

Fig. 23

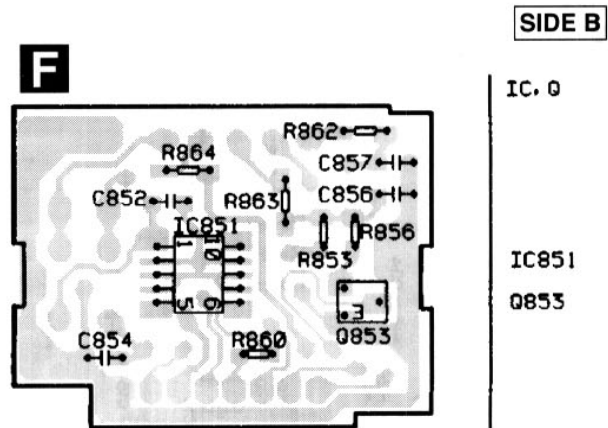

Fig. 24

5. ELECTRICAL PARTS LIST

NOTE:

- Parts whose parts numbers are omitted are subject to being not supplied.
- The part numbers shown below indicate chip components.

Chip Resistor

RS1/○S○○○○J,RS1/○○S○○○J

Chip Capacitor (except for CQS.....)

CKS....., CCS....., CSZS.....

====Circuit Symbol & No. Part Name=====	Part No.	====Circuit Symbol & No. Part Name=====	Part No.
B Unit Number : CWE1417		R 13	RS1/16S563J
Unit Name : FM/AM Tuner Unit		R 15	RS1/16S271J
		R 16	RS1/16S104J
MISCELLANEOUS		R 17	RS1/16S332J
		R 18	RS1/16S332J
IC 1 IC	PA4023B		
IC 2 IC	PA4024A	R 31	RS1/16S470J
Q 1 Transistor	2SC2412KLN	R 32	RS1/16S822J
Q 2 Transistor	DTC124EU	R 33	RS1/16S822J
Q 3 FET	3SK263	R 34	RS1/16S331J
		R 35	RS1/16S331J
Q 31 Transistor	2SC2412KLN		
Q 201 FET	2SK932	R 51	RS1/16S271J
Q 202 Transistor	2SC2412KLN	R 52	RS1/16S560J
Q 203 Transistor	DTC124EU	R 55	RS1/16S102J
D 1 Diode	RD39JS()	R 56	RS1/16S823J
		R 61	RS1/16S392J
D 2 Diode	RD39JS		
D 4 Diode	1SV250	R 62	RS1/16S273J
D 5 Diode	KV1410-F1	R 101	RS1/16S272J
D 6 Diode	MA157	R 102	RS1/16S682J
D 7 Diode	KV1410-F1	R 103	RS1/16S333J
		R 104	RS1/16S334J
D 8 Diode	KV1410-F1		
D 201 Diode	MA157	R 105	RS1/16S683J
D 202 Diode	MA157	R 107	RS1/16S222J
D 231 Diode	SVC253	R 151	RS1/16S222J
L 2 Coil	CTC1108	R 152	RS1/16S393J
		R 155	RS1/16S273J
L 3 Inductor	LCTB2R2K2125		
L 4 Coil	CTC1108	R 156	RS1/16S243J
L 5 Coil	CTC1107	R 157	RS1/16S203J
L 51 Ferri-Inductor	LAU150K	R 160	RS1/16S222J
L 201 Ferri-Inductor	LAU4R7K	R 161	RS1/16S563J
		R 162	RS1/16S105J
L 202 Ferri-Inductor	LAU330K		
L 203 Inductor	CTF1287	R 163	RS1/16S223J
L 208 Inductor	LAU121K	R 202	RS1/16S223J
L 231 Inductor	LCTA3R3J3225	R 203	RS1/16S225J
T 31 Coil	CTE1116	R 204	RS1/16S103J
		R 206	RS1/16S220J
T 51 Coil	CTC1136		
CF 51 Ceramic Filter	CTF1290	R 207	RS1/16S101J
CF 52 Ceramic Filter	CTF1290	R 208	RS1/16S102J
CF 53 Ceramic Filter	CTF1290	R 209	RS1/16S471J
CF 232 Ceramic Filter	CTF1348	R 214	RS1/16S822J
		R 215	RS1/16S822J
X 151 Resonator 920.5kHz	CSS1365		
X 231 Crystal Resonator 10.26MHz	CSS1111	R 217	RS1/16S102J
VR 154 Semi-fixed 150kΩ(B)	CCP1213	R 231	RS1/16S272J
		R 232	RS1/16S473J
		R 237	RS1/16S103J
		R 238	RS1/16S104J
RESISTORS			
R 1	RS1/16S225J		
R 2	RS1/16S225J	R 239	RS1/16S104J
R 4	RS1/16S154J	R 240	RS1/16S332J
R 5	RS1/16S391J	R 241	RS1/16S202J
R 6	RS1/16S223J	R 243	RS1/16S183J
		R 244	RS1/16S392J
R 7	RS1/16S123J		
R 8	RS1/16S332J	R 247	RS1/16S123J
R 9	RS1/16S473J		
R 10	RS1/16S223J		
R 11	RS1/16S124J		

DEH-59DH,45DH

====Circuit Symbol & No. Part Name====	Part No.
CAPACITORS	
C 1	CCSQCH6R0D50
C 2	CCSRCK2R0C50
C 4	CCSRCH820J50
C 6	CCSRCH820J50
C 8	CKSRYP103K25
C 9	CKSQYB104K16
C 10	CCSRCKR50C50
C 11	CEJA1R0M50
C 12	CKSRYP222K50
C 13	CKSRYP222K50
C 14	CCSRCH220J50
C 15	CCSRCH6R0D50
C 16	CCSRCH8R0D50
C 17	CKSRYP222K50
C 18	CKSRYP103K25
C 19	CKSRYP222K50
C 20	CKSRYP222K50
C 21	CEJA100M16
C 22	CCSRTH9R0D50
C 23	CCSRTH120J50
C 24	CCSRCH471J50
C 25	CKSRYP103K25
C 26	CCSRCH101J50
C 31	CKSRYP103K25
C 32	CKSQYB472K50
C 33	CCSRCH5R0C50
C 34	CKSQYB104K16
C 36	CCSRRH201J50
C 51	CKSRYP223K25
C 52	CKSRYP103K25
C 54	CCSRCH470J50
C 55	CKSQYB223K25
C 56	CKSQYB104K16
C 57	CKSRYP472K50
C 58	CEJA330M10
C 59	CKSRYP103K25
C 60	CKSRYP102K50
C 61	CCSRCH270J50
C 62	CKSRYP103K25
C 63	CEJAR22M50
C 101	CEJANP100M10
C 102	CKSRYP182K50
C 103	CKSRYP682K25
C 104	CEJA2R2M50
C 105	CKSRYP103K25
C 106	CCSRCH151J50
C 107	CKSRYP103K25
C 151	CKSRYP472K50
C 152	CKSQYB104K16
C 153	CEJA3R3M50
C 154	CKSQYB104K16
C 157	CEJA3R3M50
C 158	CKSYB474K16
C 159	CEJA220M6R3
C 160	CKSQYB104K16
C 161	CKSQYB104K16
C 162	CEJA3R3M50
C 163	CKSRYP102K50
C 170	CCSRCH100D50
C 201	CCSRCH471J50
C 202	CCSRCH100D50
C 203	CKSRYP332K50
C 204	CKSQYB473K16
C 205	CKSQYB473K16
C 206	CKSQYB104K16

====Circuit Symbol & No. Part Name====	Part No.
C 207	CCSRCH560J50
C 209	CKSQYB104K16
C 211	CCSRCH101J50
C 212	CEJA470M6R3
C 213	CKSRYP103K25
C 216	CCSRCH101J50
C 217	CEJA1R5M50
C 219	CCSRCH471J50
C 220	CKSRYP103K25
C 230	CKSRYP103K25
C 231	CCSRCH330J50
C 232	CCSRCH150J50
C 233	CKSQYB104K16
C 234	CEJA330M10
C 235	CKSRYP332K50
C 236	CKSQYB473K16
C 237	CCSRCH120J50
C 239	CKSRYP472K50
C 240	CEJAR47M50
C 241	CKSQYB104K16
C 242	CEJAR47M50
C 243	CEJAR33M50
C 244	CKSQYB473K16
C 245	CKSRYP333K16
C 246	CKSQYB473K16
C 250	CCSRCH471J50

A Unit Number : CWX2067(DEH-59DH)
 Unit Name : Tuner Amp Unit

MISCELLANEOUS

IC 151	IC	SN761027DL
IC 201	IC	TDA7384A
IC 501	IC	LC72146M
IC 601	IC	PD4723A
IC 661	IC	PD4623B
IC 941	IC	S-80734ANDYI
Q 201	Transistor	DTC124EK
Q 251	Transistor	IMH3A
Q 252	Transistor	IMH3A
Q 253	Transistor	IMD2A
Q 301	Transistor	DTA124EK
Q 302	Transistor	IMH3A
Q 501	Transistor	2SC2412K
Q 502	Transistor	2SK208
Q 503	Transistor	2SC2412K
Q 601	Transistor	DTC124EK
Q 661	Transistor	DTA124EK
Q 801	Transistor	2SA1037K
Q 802	Transistor	2SD1760F5
Q 803	Transistor	DTC114EK
Q 804	Transistor	DTA143EK
Q 805	Transistor	DTC114EK
Q 806	Transistor	2SC2412K
Q 807	Transistor	2SB1238
Q 808	Transistor	DTC143EK
Q 809	Transistor	2SD1864
Q 911	Transistor	2SD1760F5
Q 921	Transistor	IMX1
Q 922	Transistor	DTC114EK
Q 951	Transistor	2SD2396
Q 952	Transistor	2SB1243
Q 953	Transistor	DTC124EK
Q 954	Transistor	2SA1674
Q 955	Transistor	2SA1674
Q 956	Transistor	IMH1A

====Circuit Symbol & No. Part Name====	Part No.	====Circuit Symbol & No. Part Name====	Part No.
Q 957 Transistor	2SC2412K	R 506	RS1/10S103J
Q 958 Transistor	DTC144EK	R 508	RS1/10S472J
Q 971 Transistor	2SD2396	R 509	RS1/10S152J
Q 972 Transistor	IMD2A	R 510	RS1/10S102J
D 201 Diode	DAN202K	R 511	RS1/10S472J
D 501 Diode	DAN202K	R 512	RS1/10S103J
D 502 Diode	HZS3LL(B)	R 513	RS1/10S102J
D 801 Diode	DA204K	R 514	RS1/10S0R0J
D 802 Diode	DA204K	R 515	RS1/10S103J
D 803 Diode	DA204K	R 516	RS1/10S222J
D 804 Diode	MA3062(M)	R 517	RS1/10S473J
D 805 Diode	HZS9L(B3)	R 518	RS1/10S473J
D 806 Diode	HZS5LL(A)	R 519	RS1/10S473J
D 851 LED	BR4361F	R 520	RS1/10S224J
D 901 Diode	ERA15-02VH	R 521	RS1/10S473J
D 902 Diode	ERA15-02VH	R 522	RS1/10S473J
D 911 Diode	ERA15-02VH	R 523	RS1/10S472J
D 912 Diode	HZS6L(B1)	R 524	RS1/10S472J
D 921 Diode	HZS7L(C3)	R 525	RS1/10S222J
D 922 Diode	1SS133	R 526	RS1/10S223J
D 923 Diode	HZS7L(A1)	R 603	RS1/10S473J
D 931 Diode	ERA15-02VH	R 607	RS1/10S473J
D 932 Diode	ERA15-02VH	R 608	RS1/10S221J
D 941 Diode	DAN212K	R 609	RS1/10S682J
D 951 Diode	HZS9L(B3)	R 610	RA4C221J
D 952 Diode	HZS9L(A2)	R 611	RS1/10S682J
D 953 Diode	1SS133	R 613	RS1/10S682J
D 971 Diode	HZS9L(B1)	R 615	RS1/10S682J
L 501 Ferri-Inductor	LAU2R2K	R 617	RA4C681J
L 502 Ferri-Inductor	LAU220K	R 623	RS1/10S473J
L 601 Ferri-Inductor	LAU2R2K	R 624	RS1/10S102J
L 602 Inductor	LAU100K	R 625	RS1/10S202J
L 661 Ferri-Inductor	LAU2R2K	R 626	RS1/10S473J
L 801 Ferri-Inductor	LAU2R2K	R 627	RS1/10S473J
L 802 Transformer	MTX9005	R 628	RS1/10S473J
L 901 Choke Coil 600H	CTH1171	R 629	RS1/10S473J
X 501 7.2MHz	CSS1334	R 630	RS1/10S222J
X 601 Ceramic Resonator 4.194MHz	CSS1047	R 631	RS1/10S473J
X 661 Resonator 8.380MHz	CSS1354	R 633	RS1/10S473J
Detach Alarm Unit	CWM5291	R 634	RS1/10S473J
BZ 601 FM/AM Tuner Unit	CWE1417	R 636	RS1/10S0R0J
Buzzer	CPV1011	R 637	RS1/10S393J
		R 651	RS1/10S681J
		R 652	RS1/10S102J
		R 653	RS1/10S102J
RESISTORS			
R 133	RS1/10S162J		
R 134	RS1/10S162J		
R 151	RS1/10S272J	R 654	RS1/10S102J
R 152	RS1/10S272J	R 662	RS1/10S473J
R 153	RS1/10S151J	R 663	RS1/10S222J
		R 668	RS1/10S103J
		R 669	RS1/10S203J
R 154	RS1/10S151J		
R 201	RS1/10S103J	R 670	RS1/10S222J
R 202	RS1/10S331J	R 671	RS1/10S473J
R 204	RS1/10S103J	R 672	RS1/10S222J
R 205	RS1/10S103J	R 673	RS1/10S473J
		R 674	RS1/10S473J
R 251	RS1/10S821J		
R 252	RS1/10S821J	R 706	RS1/10S0R0J
R 253	RS1/10S471J	R 802	RS1/8S222J
R 254	RS1/10S471J	R 804	RS1/8S472J
R 255	RS1/10S223J	R 806	RS1/8S472J
		R 808	RS1/10S472J
R 256	RS1/10S223J		
R 257	RS1/10S223J	R 809	RS1/10S472J
R 258	RS1/10S223J	R 810	RS2PMF100J
R 301	RS1/10S471J	R 811	RD1/4PU471J
R 302	RS1/10S471J	R 812	RS1/10S103J
		R 813	RS1/10S224J
R 303	RS1/10S104J		
R 304	RS1/10S104J		
R 501	RS1/10S102J		
R 502	RS1/10S102J		
R 503	RS1/10S102J		

DEH-59DH,45DH

====Circuit Symbol & No. Part Name====	Part No.	====Circuit Symbol & No. Part Name====	Part No.	
R 814	RS1/10S222J	C 201	CKSYB224K16	
R 815	RD1/4PU102J	C 202	CKSYB224K16	
R 816	RS1/10S391J	C 203	CKSYB224K16	
R 817	RS1/10S752J	C 204	CKSYB224K16	
R 818	RS1/10S104J	C 205	CEHAR010M50	
R 819	RS2P300JL	C 206	3300 μ F/16V	CCH1163
R 851	RS1/8S331J	C 207	CKSQYB103K50	
R 865	RS1/10S103J	C 208	CEHAR100M16	
R 866	RS1/10S102J	C 209	CEHAR010M50	
R 867	RS1/10S473J	C 210	CEHAR330M10	
R 868	RS1/10S473J	C 251	CEJA4R7M35	
R 869	RS1/10S473J	C 252	CEJA4R7M35	
R 911	RS1/10S332J	C 253	CEJA4R7M35	
R 912	RS1/10S101J	C 254	CEJA4R7M35	
R 921	RS1/10S103J	C 255	CKSQYB221K50	
R 922	RS1/10S473J	C 256	CKSQYB221K50	
R 923	RS1/10S103J	C 257	CKSQYB221K50	
R 924	RS1/10S103J	C 258	CKSQYB221K50	
R 925	RS1/10S473J	C 301	CEJA3R3M50	
R 926	RS1/10S472J	C 302	CEJA3R3M50	
R 931	RS1/10S103J	C 501	CKSQYB223K25	
R 941	RS1/10S102J	C 502	CKSQYB223K25	
R 942	RS1/10S822J	C 503	CKSQYB103K50	
R 951	RD1/4PU221J	C 504	CKSQYB103K50	
R 952	RD1/4PU301J	C 505	CKSQYB103K50	
R 953	RS1/10S1R0J	C 506	CKSQYB473K25	
R 954	RD1/4PU331J	C 507	CKSQYB102K50	
R 955	RD1/4PU331J	C 509	CKLSR473K16	
R 956	RS1/8S472J	C 510	CKSQYB103K50	
R 957	RD1/4PU102J	C 512	CEJA100M16	
R 958	RS1/10S472J	C 513	CKSQYB103K50	
R 959	RD1/4PU102J	C 514	CCSQCH101J50	
R 960	RS1/10S472J	C 515	CCSQCH101J50	
R 961	RS1/10S103J	C 516	CKSQYB103K50	
R 962	RS1/10S473J	C 518	4.7 μ F/16V	CCH1250
R 963	RS1/10S473J	C 519	CKSQYB103K50	
R 971	RD1/4PU221J	C 520	CCSQCH150J50	
R 972	RS1/10S221J	C 521	CCSQCH150J50	
R 973	RS1/10S472J	C 522	CKSQYB223K25	
R 974	RS1/8S122J	C 603	CEJA100M16	
CAPACITORS		C 604	CKSQYB103K50	
C 133	CKSQYB473K25	C 605	CCSQCH101J50	
C 134	CKSQYB473K25	C 606	CCSQCH101J50	
C 135	CEJA4R7M35	C 607	CCSQCH101J50	
C 136	CEJA4R7M35	C 609	CASA1R0M16	
C 137	CEJA4R7M35	C 661	CCSQCH101J50	
C 138	CEJA4R7M35	C 662	CEJA4R7M35	
C 151	CKSQYB104K16	C 663	CKSQYB104K16	
C 152	CEAS470M10	C 664	CKSQYB473K25	
C 153	CEJANP100M10	C 801	CKSYB104K16	
C 154	CEJANP100M10	C 802	CCSQCH101J50	
C 155	CKSQYB822K50	C 803	CEHAR100M16	
C 156	CKSQYB822K50	C 804	CKSQYB103K50	
C 157	CEJA1R0M50	C 805	CEHAR100M16	
C 158	CEJA1R0M50	C 806	CKSQYB103K50	
C 159	CKSQYB183K25	C 807	CKSQYB333K25	
C 160	CKSQYB183K25	C 808	CKSQYB333K25	
C 161	CKSQYB102K50	C 858	CKSQYB473K25	
C 162	CKSQYB102K50	C 901	CKSQYB103K50	
C 163	CEJANP2R2M35	C 911	CKSQYB103K50	
C 164	CEJANP2R2M35	C 912	0.22F/5.5V	CCL1037
C 165	CKSQYB333K25	C 913	CKSQYB472K50	
C 166	CKSQYB333K25	C 914	CEHAQ102M16	
C 167	CEJA220M6R3	C 915	CEAS470M10	
C 168	CEJA2R2M50	C 921	CKSYB105K16	
C 169	CKSQYB104K16			

DEH-59DH,45DH

====Circuit Symbol & No. Part Name====	Part No.	====Circuit Symbol & No. Part Name====	Part No.
C 922	CKSYB102K50	D 921	Diode
C 931	CKSQYB473K25	D 922	Diode
C 941	CEJA2R2M50	D 923	Diode
C 951	CKSQYB103K50	D 931	Diode
C 952	CEHAQ101M16	D 932	Diode
C 953	CKSQYB103K50	D 941	Diode
C 954 330 μ F/10V	CCH1181	D 951	Diode
C 971	CKSQYB473K25	D 952	Diode
C 972	CKSQYB102K50	D 953	Diode
C 973	CEAS101M10	D 971	Diode
		L 501	Ferri-Inductor
		L 502	Ferri-Inductor
		L 601	Ferri-Inductor
		L 602	Inductor
		L 661	Ferri-Inductor
		L 801	Ferri-Inductor
		L 802	Transformer
		L 901	Choke Coil 600H
		X 501	7.2MHz
		X 601	Ceramic Resonator 4.194MHz
		X 661	Resonator 8.380MHz FM/AM Tuner Unit
			LAU2R2K
			LAU220K
			LAU2R2K
			LAU100K
			LAU2R2K
			LAU2R2K
			MTX9005
			CTH1171
			CSS1334
			CSS1047
			CSS1354
			CWE1417
MISCELLANEOUS			
IC 151 IC	SN761027DL		
IC 201 IC	TDA7384A		
IC 501 IC	LC72146M		
IC 601 IC	PD4723A		
IC 661 IC	PD4623B		
IC 941 IC	S-80734ANDYI		
Q 201 Transistor	DTC124EK		
Q 252 Transistor	IMH3A		
Q 253 Transistor	IMD2A		
Q 301 Transistor	DTA124EK		
Q 302 Transistor	IMH3A		
Q 501 Transistor	2SC2412K		
Q 502 Transistor	2SK208		
Q 503 Transistor	2SC2412K		
Q 661 Transistor	DTA124EK		
Q 801 Transistor	2SA1037K		
Q 802 Transistor	2SD1760F5		
Q 803 Transistor	DTC114EK		
Q 804 Transistor	DTA143EK		
Q 805 Transistor	DTC114EK		
Q 806 Transistor	2SC2412K		
Q 807 Transistor	2SB1238		
Q 808 Transistor	DTC143EK		
Q 809 Transistor	2SD1864		
Q 911 Transistor	2SD1760F5		
Q 921 Transistor	IMX1		
Q 922 Transistor	DTC114EK		
Q 951 Transistor	2SD2396		
Q 952 Transistor	2SB1243		
Q 953 Transistor	DTC124EK		
Q 954 Transistor	2SA1674		
Q 955 Transistor	2SA1674		
Q 956 Transistor	IMH1A		
Q 957 Transistor	2SC2412K		
Q 958 Transistor	DTC144EK		
Q 971 Transistor	2SD2396		
Q 972 Transistor	IMD2A		
D 201 Diode	DAN202K		
D 501 Diode	DAN202K		
D 502 Diode	HZS3LL(B)		
D 801 Diode	DA204K		
D 802 Diode	DA204K		
D 803 Diode	DA204K		
D 804 Diode	MA3062(M)		
D 805 Diode	HZS9L(B3)		
D 806 Diode	HZS5LL(A)		
D 901 Diode	ERA15-02VH		
D 902 Diode	ERA15-02VH		
D 911 Diode	ERA15-02VH		
D 912 Diode	HZS6L(B1)		
			RS1/10S162J
			RS1/10S162J
			RS1/10S272J
			RS1/10S272J
			RS1/10S151J
			RS1/10S151J
			RS1/10S103J
			RS1/10S331J
			RS1/10S103J
			RS1/10S103J
			RS1/10S471J
			RS1/10S471J
			RS1/10S223J
			RS1/10S223J
			RS1/10S471J
			RS1/10S471J
			RS1/10S104J
			RS1/10S104J
			RS1/10S102J
			RS1/10S102J
			RS1/10S102J
			RS1/10S103J
			RS1/10S472J
			RS1/10S152J
			RS1/10S102J
			RS1/10S472J
			RS1/10S103J
			RS1/10S102J
			RS1/10S102J
			RS1/10S0R0J
			RS1/10S103J
			RS1/10S222J
			RS1/10S473J
			RS1/10S473J
			RS1/10S473J
			RS1/10S473J
			RS1/10S472J
			RS1/10S472J
			RS1/10S222J

A Unit Number : CWX2068(DEH-45DH)
Unit Name : Tuner Amp Unit

MISCELLANEOUS

IC 151 IC	SN761027DL
IC 201 IC	TDA7384A
IC 501 IC	LC72146M
IC 601 IC	PD4723A
IC 661 IC	PD4623B
IC 941 IC	S-80734ANDYI
Q 201 Transistor	DTC124EK
Q 252 Transistor	IMH3A
Q 253 Transistor	IMD2A
Q 301 Transistor	DTA124EK
Q 302 Transistor	IMH3A
Q 501 Transistor	2SC2412K
Q 502 Transistor	2SK208
Q 503 Transistor	2SC2412K
Q 661 Transistor	DTA124EK
Q 801 Transistor	2SA1037K
Q 802 Transistor	2SD1760F5
Q 803 Transistor	DTC114EK
Q 804 Transistor	DTA143EK
Q 805 Transistor	DTC114EK
Q 806 Transistor	2SC2412K
Q 807 Transistor	2SB1238
Q 808 Transistor	DTC143EK
Q 809 Transistor	2SD1864
Q 911 Transistor	2SD1760F5
Q 921 Transistor	IMX1
Q 922 Transistor	DTC114EK
Q 951 Transistor	2SD2396
Q 952 Transistor	2SB1243
Q 953 Transistor	DTC124EK
Q 954 Transistor	2SA1674
Q 955 Transistor	2SA1674
Q 956 Transistor	IMH1A
Q 957 Transistor	2SC2412K
Q 958 Transistor	DTC144EK
Q 971 Transistor	2SD2396
Q 972 Transistor	IMD2A
D 201 Diode	DAN202K
D 501 Diode	DAN202K
D 502 Diode	HZS3LL(B)
D 801 Diode	DA204K
D 802 Diode	DA204K
D 803 Diode	DA204K
D 804 Diode	MA3062(M)
D 805 Diode	HZS9L(B3)
D 806 Diode	HZS5LL(A)
D 901 Diode	ERA15-02VH
D 902 Diode	ERA15-02VH
D 911 Diode	ERA15-02VH
D 912 Diode	HZS6L(B1)

RESISTORS

R 133	RS1/10S162J
R 134	RS1/10S162J
R 151	RS1/10S272J
R 152	RS1/10S272J
R 153	RS1/10S151J
R 154	RS1/10S151J
R 201	RS1/10S103J
R 202	RS1/10S331J
R 204	RS1/10S103J
R 205	RS1/10S103J
R 253	RS1/10S471J
R 254	RS1/10S471J
R 257	RS1/10S223J
R 258	RS1/10S223J
R 301	RS1/10S471J
R 302	RS1/10S471J
R 303	RS1/10S104J
R 304	RS1/10S104J
R 501	RS1/10S102J
R 502	RS1/10S102J
R 503	RS1/10S102J
R 506	RS1/10S103J
R 508	RS1/10S472J
R 509	RS1/10S152J
R 510	RS1/10S102J
R 511	RS1/10S472J
R 512	RS1/10S103J
R 513	RS1/10S102J
R 514	RS1/10S0R0J
R 515	RS1/10S103J
R 516	RS1/10S222J
R 517	RS1/10S473J
R 518	RS1/10S473J
R 519	RS1/10S473J
R 520	RS1/10S224J
R 521	RS1/10S473J
R 522	RS1/10S473J
R 523	RS1/10S472J
R 524	RS1/10S472J
R 525	RS1/10S222J

DEH-59DH,45DH

====Circuit Symbol & No. Part Name====	Part No.	====Circuit Symbol & No. Part Name====	Part No.
R 526	RS1/10S223J	R 959	RD1/4PU102J
R 603	RS1/10S473J	R 960	RS1/10S472J
R 607	RS1/10S473J	R 961	RS1/10S103J
R 608	RS1/10S221J	R 962	RS1/10S473J
R 609	RS1/10S682J	R 963	RS1/10S473J
R 610	RA4C221J	R 971	RD1/4PU221J
R 611	RS1/10S682J	R 972	RS1/10S221J
R 613	RS1/10S682J	R 973	RS1/10S472J
R 615	RS1/10S682J	R 974	RS1/8S122J
R 617	RA4C681J		
R 623	RS1/10S473J		
R 626	RS1/10S473J	CAPACITORS	
R 627	RS1/10S473J	C 133	CKSQYB473K25
R 628	RS1/10S473J	C 134	CKSQYB473K25
R 629	RS1/10S473J	C 135	CEJA4R7M35
R 630	RS1/10S222J	C 136	CEJA4R7M35
R 631	RS1/10S473J	C 137	CEJA4R7M35
R 633	RS1/10S473J	C 138	CEJA4R7M35
R 635	RS1/10S473J	C 151	CKSQYB104K16
R 636	RS1/10S0R0J	C 152	CEAS470M10
R 637	RS1/10S393J	C 153	CEJANP100M10
R 651	RS1/10S681J	C 154	CEJANP100M10
R 652	RS1/10S102J	C 155	CKSQYB822K50
R 653	RS1/10S102J	C 156	CKSQYB822K50
R 654	RS1/10S102J	C 157	CEJA1R0M50
R 662	RS1/10S473J	C 158	CEJA1R0M50
R 663	RS1/10S222J	C 159	CKSQYB183K25
R 668	RS1/10S103J	C 160	CKSQYB183K25
R 669	RS1/10S203J	C 161	CKSQYB102K50
R 670	RS1/10S222J	C 162	CKSQYB102K50
R 671	RS1/10S473J	C 163	CEJANP2R2M35
R 672	RS1/10S222J	C 164	CEJANP2R2M35
R 673	RS1/10S473J	C 165	CKSQYB333K25
R 674	RS1/10S473J	C 166	CKSQYB333K25
R 706	RS1/10S0R0J	C 167	CEJA220M6R3
R 802	RS1/8S222J	C 168	CEJA2R2M50
R 804	RS1/8S472J	C 169	CKSQYB104K16
R 806	RS1/8S472J	C 201	CKSYB224K16
R 808	RS1/10S472J	C 202	CKSYB224K16
R 809	RS1/10S472J	C 203	CKSYB224K16
R 810	RS2PMF100J	C 204	CKSYB224K16
R 811	RD1/4PU471J	C 205	CEHAR010M50
R 812	RS1/10S103J	C 206	3300 μ F/16V
R 813	RS1/10S224J	C 207	CCH1163
R 814	RS1/10S222J	C 208	CKSQYB103K50
R 815	RD1/4PU102J	C 209	CEHAR100M16
R 816	RS1/10S391J	C 210	CEHAR010M50
R 817	RS1/10S752J	C 253	CEHAR330M10
R 818	RS1/10S104J	C 254	CEJA4R7M35
R 819	RS2P300JL	C 257	CEJA4R7M35
R 868	RS1/10S473J	C 258	CKSQYB221K50
R 911	RS1/10S332J	C 301	CKSQYB221K50
R 912	RS1/10S101J	C 302	CEJA3R3M50
R 921	RS1/10S103J	C 501	CKSQYB223K25
R 922	RS1/10S473J	C 502	CKSQYB223K25
R 923	RS1/10S103J	C 503	CKSQYB103K50
R 924	RS1/10S103J	C 504	CKSQYB103K50
R 925	RS1/10S473J	C 505	CKSQYB103K50
R 926	RS1/10S472J	C 506	CKSQYB473K25
R 931	RS1/10S103J	C 507	CKSQYB102K50
R 941	RS1/10S102J	C 509	CKLSR473K16
R 942	RS1/10S822J	C 510	CKSQYB103K50
R 951	RD1/4PU221J	C 512	CEJA100M16
R 952	RD1/4PU301J	C 513	CKSQYB103K50
R 953	RS1/10S1R0J	C 514	CCSQCH101J50
R 954	RD1/4PU331J	C 515	CCSQCH101J50
R 955	RD1/4PU331J	C 516	CKSQYB103K50
R 956	RS1/8S472J		
R 957	RD1/4PU102J		
R 958	RS1/10S472J		

DEH-59DH,45DH

====Circuit Symbol & No. Part Name====	Part No.	====Circuit Symbol & No. Part Name====	Part No.
C 518 4.7 μ F/16V	CCH1250	S 1909	CSG1061
C 519	CKSQYB103K50	S 1910	CSG1061
C 520	CCSQCH150J50	S 1911	CSG1084
C 521	CCSQCH150J50	S 1912	CSG1084
C 522	CKSQYB223K25	S 1913	CSG1084
C 603	CEJA100M16	S 1914	CSG1084
C 604	CKSQYB103K50	S 1915	CSG1084
C 605	CCSQCH101J50	S 1916	CSG1084
C 606	CCSQCH101J50	S 1917	CSG1085
C 607	CASA1R0M16	S 1918	CSG1084
C 609	CCSQCH101J50	S 1919	CSG1084
C 661	CCSQCH101J50	S 1920	CSG1084
C 662	CEJA4R7M35	S 1921	CSG1086
C 663	CKSQYB104K16		CAW1390
C 664	CKSQYB473K25	LCD	CEL1488
		EL	
C 801	CKSYB104K16	RESISTORS	
C 802	CCSQCH101J50		
C 803	CEHAR100M16	R 1901	RS1/8S222J
C 804	CKSQYB103K50	R 1902	RS1/8S222J
C 805	CEHAR100M16	R 1903	RS1/8S562J
		R 1904	RS1/8S470J
C 806	CKSQYB103K50	R 1905	RS1/8S2R2J
C 807	CKSQYB333K25		
C 808	CKSQYB333K25	R 1906	RS1/8S121J
C 901	CKSQYB103K50	R 1907	RS1/8S121J
C 911	CKSQYB103K50	R 1908	RS1/8S121J
		R 1909	RS1/8S121J
C 912 0.22F/5.5V	CCL1037	R 1910	RS1/8S121J
C 913	CKSQYB472K50		
C 914	CEHAQ102M16	R 1911	RS1/8S121J
C 915	CEAS470M10	R 1912	RS1/8S121J
C 921	CKSYB105K16	R 1913	RS1/8S121J
		R 1914	RS1/8S121J
C 922	CKSYB102K50	R 1915	RS1/8S121J
C 931	CKSQYB473K25		
C 941	CEJA2R2M50	R 1918	RS1/8S0R0J
C 951	CKSQYB103K50	R 1919	RS1/8S0R0J
C 952	CEHAQ101M16		
		CAPACITORS	
C 953	CKSQYB103K50		
C 954 330 μ F/10V	CCH1181	C 1901	CKSQYB103K50
C 971	CKSQYB473K25	C 1902	CEV470M6R3
C 972	CKSQYB102K50	C 1903	CKSQYB104K16
C 973	CEAS101M10	C 1904	CKSQYB104K16
		C 1905	CKSYB104K25
		C 1906	CKSQYB104K16

C Unit Number : CWX2091
Unit Name : Keyboard Unit

MISCELLANEOUS

IC 1901 IC	PD6197A
IC 1902	RS-140
D 1901 Diode	DA204K
D 1902 Diode	DA204K
D 1903 LED	CL220PGC
D 1904 LED	CL220PGC
D 1905 LED	CL220PGC
D 1906 LED	CL170PGCD
D 1907 LED	CL170PGCD
D 1908 LED	CL170PGCD
L 1901 Inductor	LCTB1R0K2125
X 1901	CSS1084
S 1901	CSG1085
S 1902	CSG1084
S 1903	CSG1085
S 1904	CSG1085
S 1905	CSG1085
S 1906	CSG1085
S 1907	CSG1085
S 1908	CSG1085

E Unit Number : CWX1889
Unit Name : Control Unit

MISCELLANEOUS

IC 101 IC	UPC2572GS
IC 201 IC	UPD63702GF
IC 301 IC	XLA6997FP
IC 302 IC	XLA6285FP
IC 601 IC	TA2063F
IC 701 IC	PQ05TZ51
Q 101 Transistor	2SD1664
Q 102 Transistor	UMD2N
Q 601 Transistor	2SD1781K
Q 602 Transistor	2SD1781K
Q 603 Transistor	2SB709A
D 601 Diode	MA151WA
D 701 Diode	1SR154-400
D 702 Diode	1SR154-400
D 801	CL200IRX
D 802	CL200IRX
X 201 Ceramic Resonator 16.93MHz	CSS1363
S 801 Switch(Home)	CSN1028
S 802 Switch(Clamp)	CSN1028

DEH-59DH,45DH

====Circuit Symbol & No. Part Name====	Part No.
RESISTORS	
R 101	RS1/8S100J
R 102	RS1/8S120J
R 103	RS1/16S102J
R 104	RS1/16S822J
R 105	RS1/16S682J
R 106	RS1/16S183J
R 107	RS1/16S822J
R 108	RS1/16S333J
R 109	RS1/16S683J
R 110	RS1/16S134J
R 111	RS1/16S273J
R 112	RS1/16S222J
R 113	RS1/16S103J
R 114	RS1/16S103J
R 115	RS1/16S102J
R 116	RS1/16S163J
R 117	RS1/16S163J
R 201	RS1/16S104J
R 202	RS1/16S473J
R 304	RS1/16S0R0J
R 501	RS1/16S0R0J
R 505	RS1/16S102J
R 507	RA4C102J
R 508	RA4C681J
R 510	RS1/10S0R0J
R 601	RS1/16S102J
R 602	RS1/16S102J
R 603	RS1/16S223J
R 604	RS1/16S223J
R 605	RS1/16S162J
R 606	RS1/16S162J
R 607	RS1/16S103J
R 801	RS1/8S751J
R 802	RS1/8S751J
CAPACITORS	
C 101	CEV101M6R3
C 102	CKSQYB104K16
C 103	CEV470M6R3
C 104	CKSYB334K16
C 105	CCSRCH330J50
C 106	CKSRYB103K25
C 107	CEV4R7M35
C 108	CKSQYB273K50
C 109	CCSRCH101J50
C 110	CKSQYB104K16
C 111	CKSRYB332K50
C 112	CKSQYB473K16
C 113	CKSRYB103K25
C 114	CKSRYB391K50
C 115	CCSRCH121J50
C 116	CKSRYB682K25
C 117	CKSRYB333K16
C 118	CKSYB334K16
C 119	CKSYB334K16
C 120	CKSYB334K16
C 121	CKSYB334K16
C 122	CKSQYB104K16
C 123	CKSRYB472K50
C 124	CKSQYB104K16
C 125	CCSRCH6R0D50
C 126	CKSRYB153K25
C 127	CCSRCH102J25
C 201	CKSYB334K16
C 202	CKSQYB104K16
C 203	CKSQYB104K16

====Circuit Symbol & No. Part Name====	Part No.
C 303	CEV470M16
C 304	CKSRYB103K25
C 305	CKSRYB103K25
C 306	CKSRYB103K25
C 502	CKSRYB471K50
C 601	CEV101M6R3
C 602	CKSQYB104K16
C 603	CEV4R7M35
C 604	CEV4R7M35
C 605	CKSRYB152K50
C 606	CKSRYB152K50
C 607	CEV220M6R3
C 701	22 μ F/6.3V
C 702	CCH1233
C 703	CKSYB334K16
C 901	CEV101M6R3
C 902	CCSRCH471J50
C 903	CCSRCH271J50
C 904	CCSRCH471J50
C 904	CCSRCH101J50

F Unit Number : CWM5291(DEH-59DH)
Unit Name : Detach Alarm Unit

MISCELLANEOUS

IC 851	IC	TPD1018F
IC 852	IC	TPD1018F
Q 851	Transistor	IMD2A
Q 852	Transistor	DTC123EK
Q 853	Transistor	DTC123EK
Q 854	Transistor	DTC123EK
D 858	Diode	ERA15-02VH
D 859	Diode	ERA15-02VH
D 860	Diode	ERA15-02VH
D 861	Diode	ERA15-02VH

RESISTORS

R 852	RS1/10S103J
R 853	RS1/10S103J
R 854	RS1/10S163J
R 856	RS1/10S163J
R 858	RS1/10S163J
R 860	RS1/10S103J
R 861	RS1/10S103J
R 862	RS1/8S102J
R 863	RS1/8S102J
R 864	RS1/8S102J

CAPACITORS

C 852	CKSQYB473K25
C 854	CKSQYB473K25
C 855	CKSQYB103K50
C 856	CKSQYB103K50
C 857	CKSQYB103K50

D Unit Number :
Unit Name : Detector PCB

Q 1	Photo-transistor	CPT-230S-X
Q 2	Photo-transistor	CPT-230S-X

Miscellaneous Parts List

M 1	Pickup Unit(SERVICE)	CXX1230
M 2	Motor Unit(Spindle)	CXA8912
M 3	CRG Motor Unit(Carriage)	CXA8986
M 3	Load Motor Unit>Loading)	CXA8702

6. ADJUSTMENT

6.1 TUNER ADJUSTMENT

● Connection Diagram

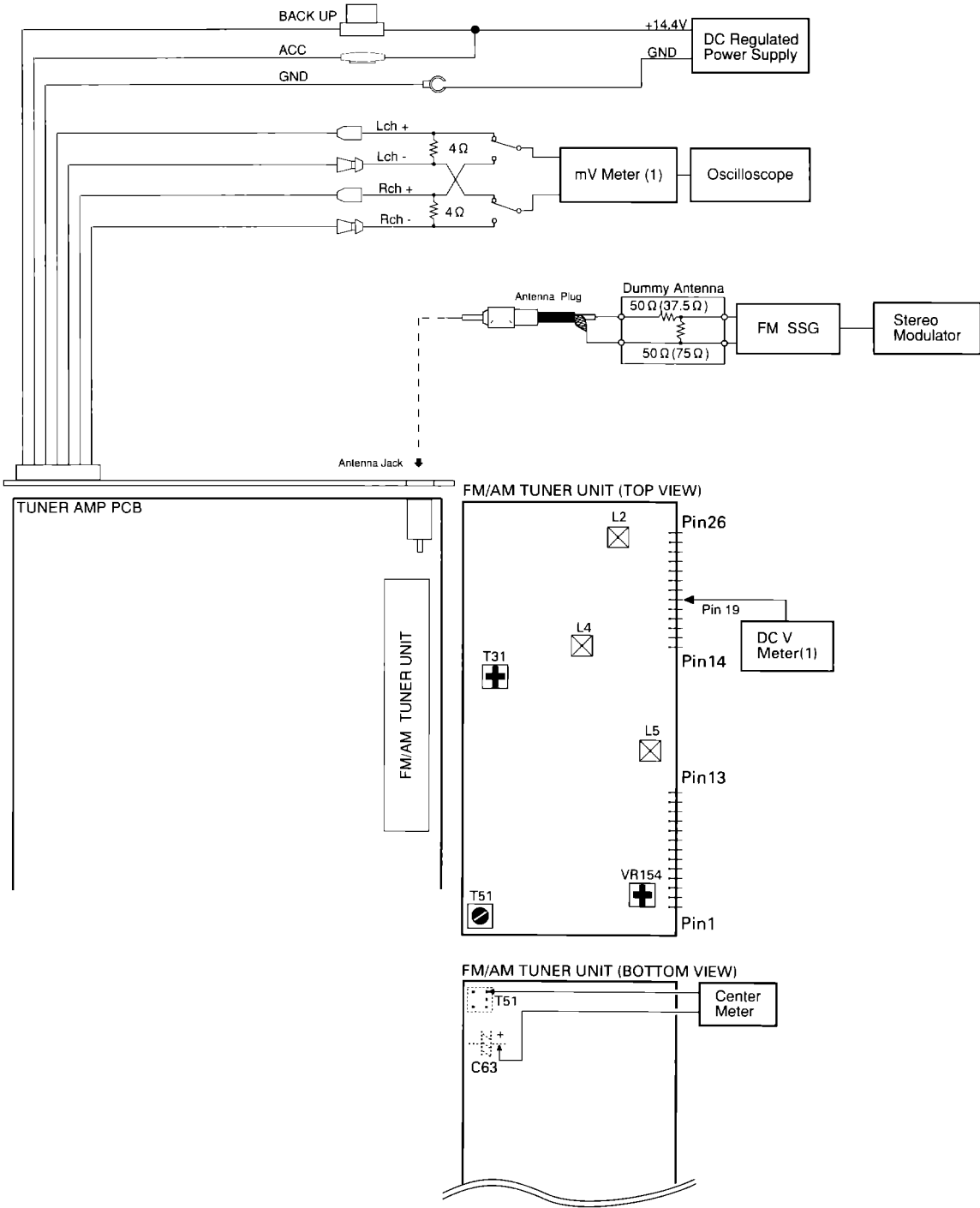

Fig. 25

DEH-59DH,45DH

FM ADJUSTMENT

Modulation M:MONO MOD., 400Hz 30%(22.5kHz Dev.) or 400Hz 100%(75kHz Dev.)

S:STEREO MOD., 1kHz, L or R=30%(20.25kHz+7.5kHz Dev.)

NOTE:Before proceeding to further adjustments after switching power ON, let the tuner run for ten minutes to allow the circuits to stabilize.

	No.	FM SSG		Displayed Frequency(MHz)	Adjustment Point	Adjustment Method (Switch Position)
		Frequency(MHz)	Level(dBf)			
TUN Volt	1	*****	*****	107.9	L5	DC V Meter(1) : 6V
IF	2	98.1 M	60	98.1	T51	Center Meter : 0
ANT Coil	3	98.1 M	5	98.1	L2	mV Meter(1) : Maximum
RF Coil	4	98.1 M	5	98.1	L4	mV Meter(1) : Maximum
IFT	5	98.1 M	5	98.1	T31	mV Meter(1) : Maximum (STEREO MODE)
ARC	6	98.1 S	40	98.1	VR154	mV Meter(1) : Separation 5dB (STEREO MODE)

6.2 CHECKING THE KEYBOARD UNIT

When checking the Keyboard unit and Tuner Amp PCB , set the unit as shown in the figure. Secure the Keyboard unit by using adhesive tape to prevent it from becoming unstable during the check.

Even without the CD mechanism module, the minimum necessary items, such as the EL check, can be checked.

In the Keyboard unit and Tuner Amp PCB, there are EL high-voltage sections with the description of "HIGH VOLTAGE". Therefore, special care should be taken when handling them to prevent electrical shock.

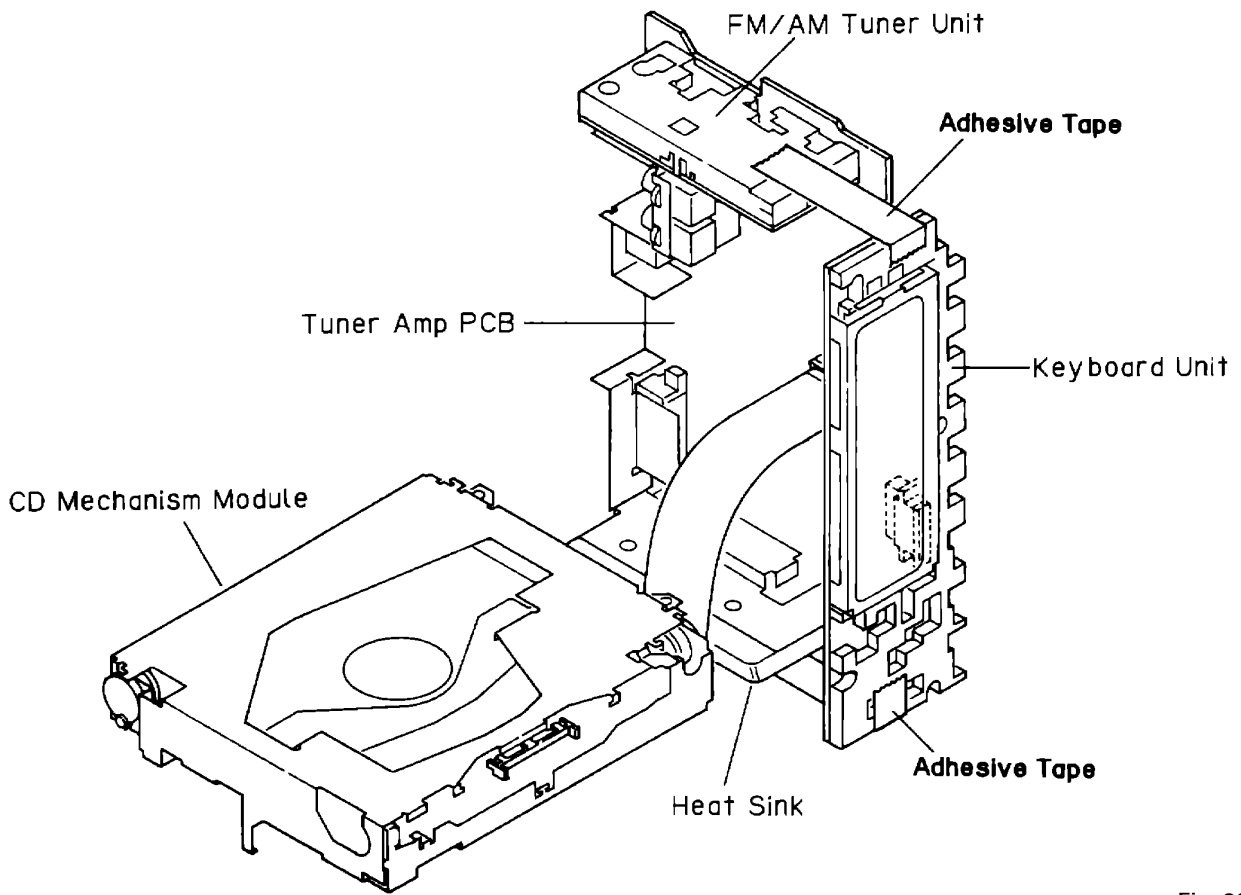

Fig. 26

6.3 CD ADJUSTMENT

1)Precautions

- This unit uses a single power supply (+5V) for the regulator. The signal reference potential, therefore, is connected to REFO(approx. 2.5V) instead of GND. If REFO and GND are connected to each other by mistake during adjustments, not only will it be impossible to measure the potential correctly, but the servo will malfunction and a severe shock will be applied to the pick-up. To avoid this, take special note of the following.
Do not connect the negative probe of the measuring equipment to REFO and GND together. It is especially important not to connect the channel 1 negative probe of the oscilloscope to REFO with the channel 2 negative probe connected to GND.
Since the frame of the measuring instrument is usually at the same potential as the negative probe, change the frame of the measuring instrument to floating status.
If by accident REFO comes in contact with GND, immediately switch the regulator or power OFF.
- Always make sure the regulator is OFF when connecting and disconnecting the various filters and wiring required for measurements.
- Before proceeding to further adjustments and measurements after switching regulator ON, let the player run for about one minute to allow the circuits to stabilize.
- Since the protective systems in the unit's software are rendered inoperative in test mode, be very careful to avoid mechanical and /or electrical shocks to the system when making adjustment.
- Test mode starting procedure
Switch ACC, back-up ON while pressing the **4** and **6** keys together.

- Test mode cancellation
Switch ACC, back-up OFF.
- Disc detection during loading and eject operations is performed by means of a photo transistor in this unit. Consequently, if the inside of the unit is exposed to a strong light source when the outer casing is removed for repairs or adjustment, the following malfunctions may occur.
*During PLAY, even if the eject button is pressed, the disc will not be ejected and the unit will remain in the PLAY mode.
*The unit will not load a disc.
When the unit malfunctions this way, either re-position the light source, move the unit or cover the photo transistor.
- When loading and unloading discs during adjustment procedures, always wait for the disc to be properly clamped or ejected before pressing another key. Otherwise, there is a risk of the actuator being destroyed.
- Turn power off when pressing the button ▷ or the button ◁ key for focus search in the test mode. (Or else lens may stick and the actuator may be damaged.)
- SINGLE/4TRK/10TRK/32TRK will continue to operate even after the key is released. Tracking is closed the moment C-MOVE is released.
- JUMP MODE resets to SINGLE as soon as power is switched OFF.

6.4 CHECKING THE GRATING

● Checking the Grating After Changing the Pickup Unit

·Note :

Unlike previous CD mechanism modules the grating angle of the PU unit cannot be adjusted after the PU unit is changed. The PU unit in the CD mechanism module is adjusted on the production line to match the CD mechanism module and is thus the best adjusted PU unit for the CD mechanism module. Changing the PU unit is thus best considered as a last resort. However, if the PU unit must be changed, the grating should be checked using the procedure below.

·Purpose :

To check that the grating is within an acceptable range.

·Symptoms of Mal-adjustment :

If the grating is off by a large amount symptoms such as being unable to close tracking, being unable to perform track search operations, or track searching taking a long time, may appear.

·Method :

- | | |
|----------------------|---------------------------|
| ·Measuring Equipment | ·Oscilloscope, Two L.P.F. |
| ·Measuring Points | ·E, F, REFOUT |
| ·Disc | ·ABEX TCD-784 |
| ·Mode | ·TEST MODE |

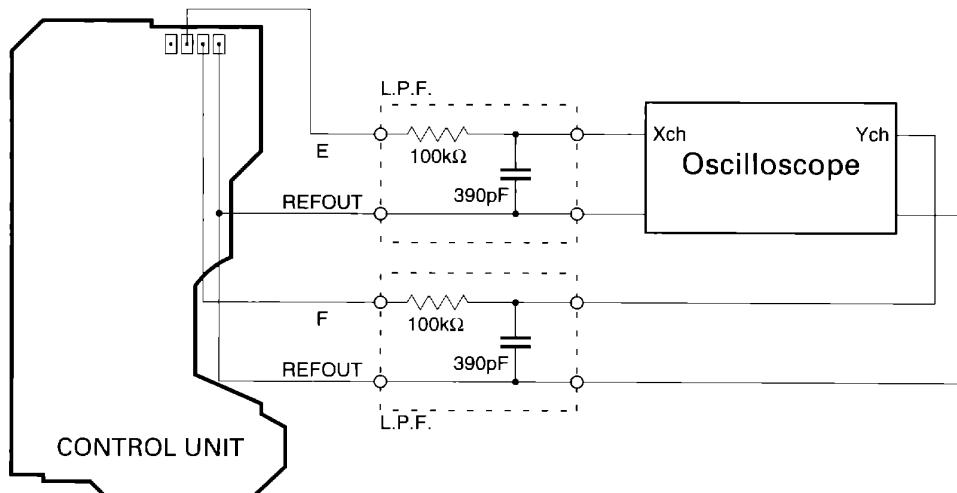

·Checking Procedure

1. In test mode, load the disc and switch the 5V regulator on.
2. Using the **TR+** and **TR-** buttons, move the PU unit to the innermost track.
3. Press key **9** to close focus, the display should read "91". Press key **8** to implement the tracking balance adjustment the display should now read "81". Press key **9** 4 times. The display will change, returning to "81" on the fourth press.
4. As shown in the diagram above, monitor the L.P.F. outputs using the oscilloscope and check that the phase difference is within 75°. Refer to the photographs supplied to determine the phase angle.
5. If the phase difference is determined to be greater than 75° try changing the PU unit to see if there is any improvement. If, after trying this a number of times, the grating angle does not become less than 75° then the mechanism should be judged to be at fault.

·Note

Because of eccentricity in the disc and a slight misalignment of the clamping center the grating waveform may be seen to "wobble" (the phase difference changes as the disc rotates). The angle specified above indicates the average angle.

·Hint

Reloading the disc changes the clamp position and may decrease the "wobble".

DEH-59DH,45DH

Grating waveform

Ech → Xch 20mV/div, AC
Fch → Ych 20mV/div, AC

0°

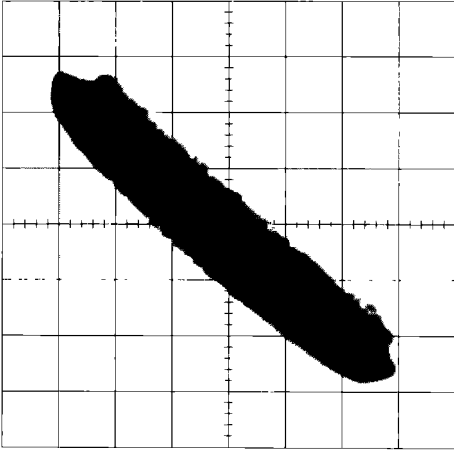

30°

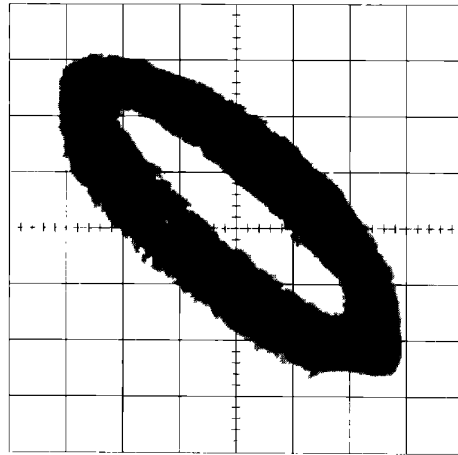

45°

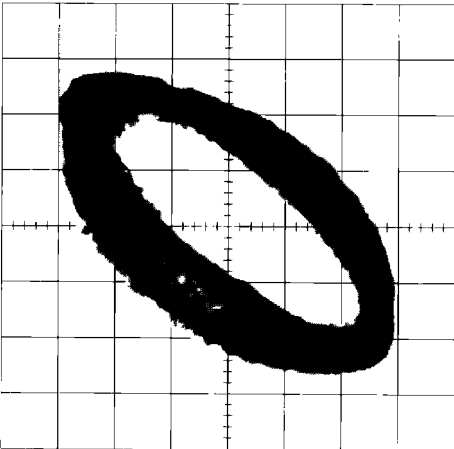

60°

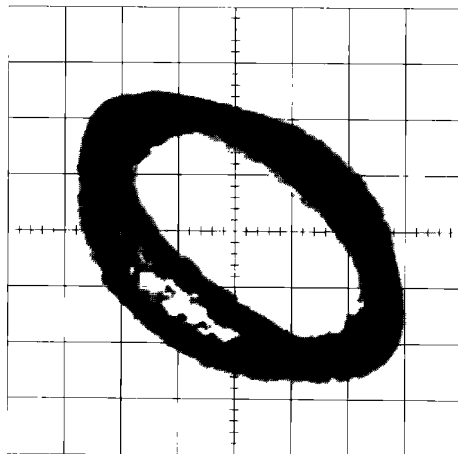

75°

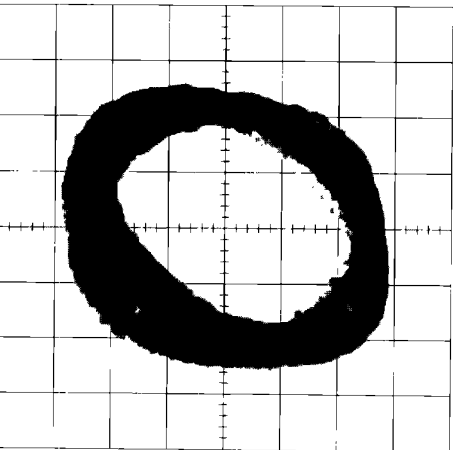

90°

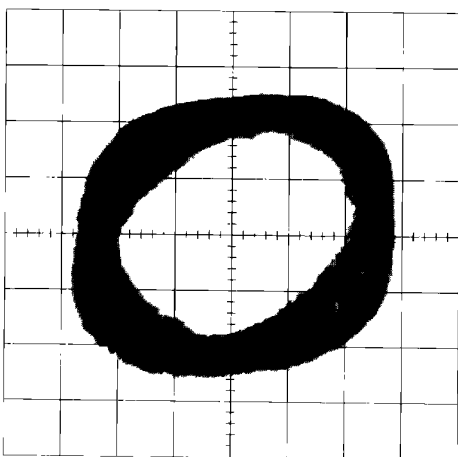

6.5 TEST MODE

● Flow Chart

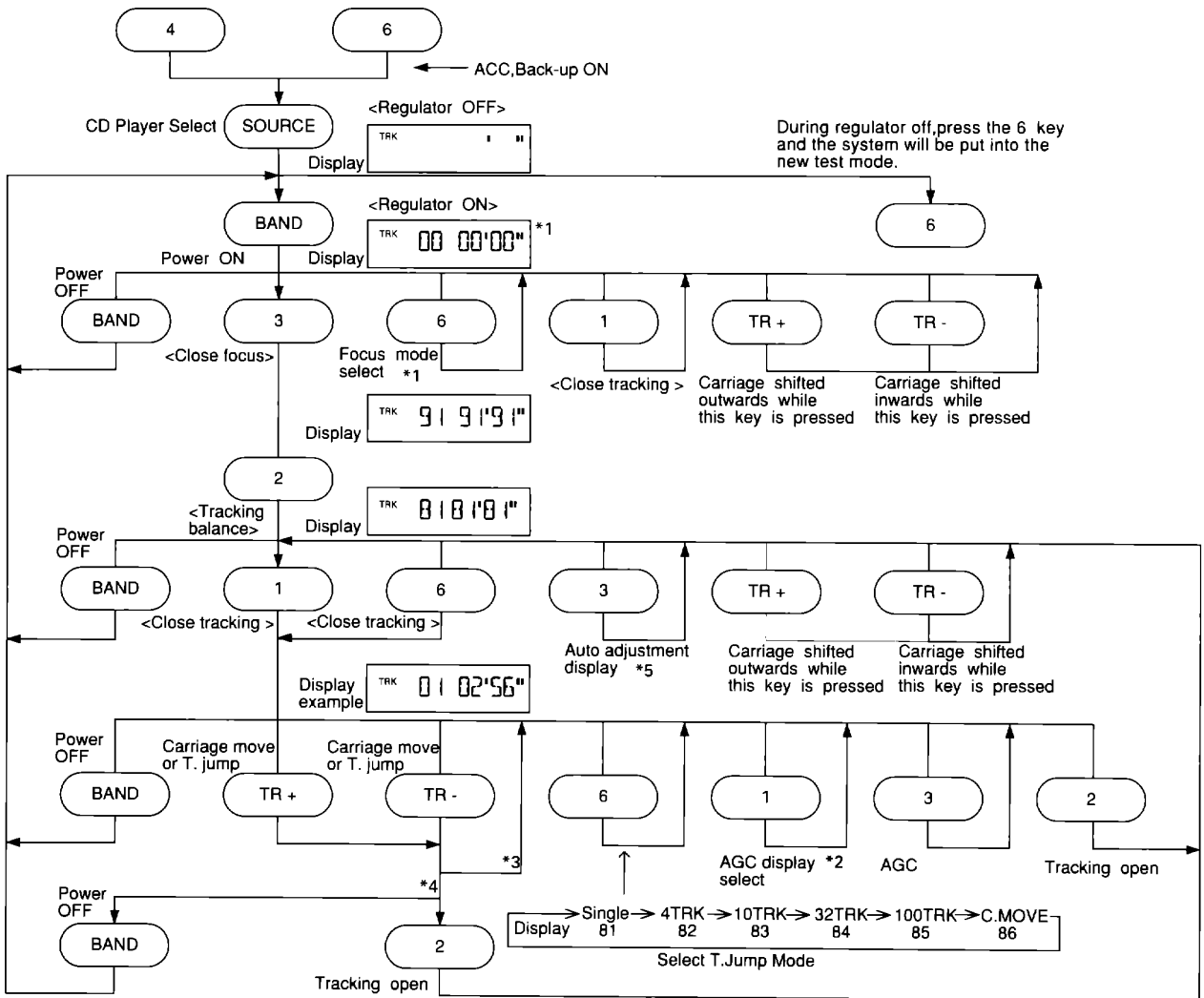

- *1

Normal focus close	→	S curve check	→	Focus EQ check
00 00 00		01 01 01		02 02 02
- *2

Normal display	→	Focus gain	→	Track gain
----------------	---	------------	---	------------
- *3 100 TRK jump & carriage move continue only while the keys are pressed
- *4 SINGLE/4/10/32 → continuous even after key release
- *5

Normal display	→	Focus gain	→	Tracking offset	→	Tracking balance
(Close spindle-rough)						

7. GENERAL INFORMATION

7.1 PARTS

7.1.1 IC

● Pin Functions (UPC2572GS)

Pin No.	Pin Name	I/O	Function and Operation
1	EFM-IN	I	EFM comparator input
2	AGC-OUT	O	AGC amplifier output
3	C. AGC		Connects AGC peak detection condenser
4	RF-IN	I	RF signal DC component cut input
5	RF-OUT	O	RF amplifier output
6	RF-	I	RF amplifier inverted input
7	C1, 3T		Connects RF3T component detection condenser
8	C2, 3T		Connects RF3T component detection condenser
9	Vcc		Power supply
10	A	I	A signal input
11	C	I	C signal input
12	B	I	B signal input
13	D	I	D signal input
14	F	I	F signal input
15	E	I	E signal input
16	PD	I	APC amplifier input
17	LD	O	APC amplifier output
18	LDON	I	Laser diode ON/OFF input
19	VREF-OUT	O	Reference voltage output
20	VREF-IN	I	Reference voltage input
21	DET-OUT	O	Vibration detection circuit output
22	DET-IN	I	Vibration detection circuit input
23	TE-OUT2	O	Tracking error amplifier output (fourfold gain)
24	TE-OUT1	O	Tracking error amplifier output (singlefold gain)
25	TE-	I	Tracking error amplifier inverted input
26	GND		GND
27	FE-	I	Focus error amplifier inverted input
28	FE-OUT	O	Focus error amplifier output
29	C.FE	I	Focus error signal DC component cut input
30	3T-OUT	O	RF3T component output
31	MIRR	O	MIRR signal output
32	RFOK	O	RFOK signal output
33	DEFECT	O	DEFECT signal output
34	C. DEF		Connects DEFECT signal detection condenser
35	EFM-OUT	O	EFM comparator output
36	ASY	I	EFM comparator level input
37	TE-BAL	I	Tracking balance control
38	FE-BAL	I	Focus balance control

UPC2572GS

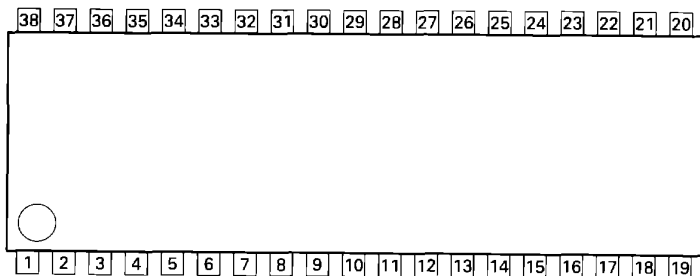

● Pin Functions (UPD63702GF)

Pin No.	Pin Name	I/O	Function and Operation
1	D.VDD		Supplies current of positive voltage to the logic circuits
2	RST	I	System reset input pin
3	AO	I	Microcomputer interface AO="L": STB active and set to address register AO="H": STB active and set to parameter
4	STB	I	Signal to latch serial data within the LSI
5	SCK	I	Clock input pin to input and output serial data
6	SO	O	Outputs serial data and status signal
7	SI	I	Serial data input pin
8	D.GND		Logic circuit GND
9	X.GND		Crystal oscillation circuit GND
10	XTAL	I	Crystal oscillator connection pin
11	XTAL	O	Crystal oscillator connection pin
12	X.VDD		Supplies current of positive voltage to the crystal oscillation circuit
13	DA.VDD		Supplies current of positive voltage to the D/A converter
14	R+	O	Right channel analog audio data output pin
15	R-	O	Right channel analog audio data output pin
16,17	DA.GND		D/A converter GND
18	L-	O	Left channel analog audio data output pin
19	L+	O	Left channel analog audio data output pin
20	DA.VDD		Supplies current of positive voltage to the D/A converter
21	D.VDD		Supplies current of positive voltage to logic circuit
22	FLAG	O	Flag output pin to indicate that audio data currently being output consists of noncorrectable data
23	WDCK	O	Pin to output double the frequency of LRCK
24	C16M	O	Pin to output the clock
25	EMPH	O	Output pin for the pre-emphasis data in the sub-Q code
26	DIN	I	Input pin for serial audio data
27	DOUT	O	Output pin for the serial audio data
28	SCKO	O	Output pin for the clock for the serial audio data
29	LRCK	O	Signals to distinguish the right and left channels of the audio data output from DOUT. Frequency is 44.1kHz at 50% duty at normal regeneration
30	TX	O	Output pin for the digital audio interface data
31	CTLV	I	Oscillation control pin for high-frequency clock generation VCO used for the digital PLL upon regeneration at fast speed of 2- or 4-fold
32	POUT	O	Output point for phase comparison
33	D.GND		GND for the logic circuit
34	VCO	I	Input pin for the inverter
35	VCO	O	Output pin for the inverter
36	D.VDD		Supplies current of positive voltage to the logic circuit
37	PLCK	O	Pin for monitoring the bit clock
38	LOCK	O	Indicates "H" when the synchronized pattern detection signal matches the frame counter output at the EFM recovery modulation, and "L" when they don't match
39	WFCK	O	Minute-cycle signal for the bit clock, the signal indicates the cycle of 1 frame (approx. 7.35kHz)
40	RFCK	O	Minute-cycle signal for the clock, the signal indicates cycle of 1 frame (approx. 7.35kHz)
41	D.GND		GND for the logic circuit
42,43	TEST0,1	I	Test pins
44,45	TM2, TM4	I	Pins for controlling regeneration at fast speed of 2- or 4-fold
46-49	T4-T7	I	Test pins
50,51	C1D1, C1D2	O	Output pin for indicating the C1 error correction results
52-54	C2D1-C2D3	O	Output pin for indicating the C2 error correction results
55	D.VDD		Supplies current of positive voltage to the logic circuit
56	SFSY	O	Outputs 1 word of the subcode. Generally, 1 cycle is approx 136 micro seconds
57	SBSY	O	The signal indicates the beginning of the subcode block. The SFSY signal is output at high level every 98 times
58	SBSO	O	Output pin for the subcode data

DEH-59DH,45DH

Pin No.	Pin Name	I/O	Function and Operation
59	SBCK	I	Input pin for the clock signal for read-out of the subcode data
60	A.GND		GND for the analog circuit
61	MD	O	Output pin for the spindle drive
62	SD	O	Output pin for the sled drive
63	TD	O	Output pin for the tracking drive
64	FD	O	Output pin for the focus drive
65	FBAL	O	Output pin for the focus balance control
66	TBAL	O	Output pin for the tracking balance control
67	A.VDD		Supplies current of positive voltage to the analog circuit
68	TBC	I	Switches coefficient banks for the tracking filter
69	EFM	I	Input pin for the EFM signal
70	HOLD	I	Input pin for the hold control signal
71	RFOK	I	Input pin for the RFOK signal
72	MIRR	I	Input pin for the MIRR signal
73	A.GND		GND for the analog circuit
74	HOME	I	Home position detector input
75	VR1	I	The signal input through these pins is digitized to 8-bit by the A/D converter, which by operation of the assigned register, can be read into the microcomputer
76	FE	I	Inputs a focus-error signal from the RF amplifier
77	TE	I	Inputs a tracking-error signal from the RF amplifier
78	TEC	I	Input pin for the tracking comparator
79	REFOUT	O	Output point for midpoint potential for the A/D converter for the LSI portion
80	A.VDD		Supplies current of accurate voltage to the analog circuit

*UPD63702GF

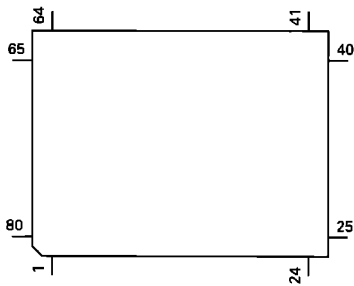

IC's marked by* are MOS type.

Be careful in handling them because they are very liable to be damaged by electrostatic induction.

*PD4623B

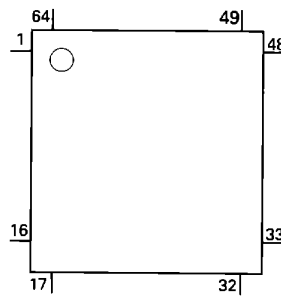

● Pin Functions (PD4623B)

Pin No.	Pin Name	I/O	Format	Function and Operation
1	NC			Not used
2	XRST	O	C	CD LSI reset output
3,4	NC			Not used
5	DCE	O	C	Chip enable output
6	CRST	O	C	IP-BUS reset output
7	HOME			Connect to VDD
8	CLAMP	I		Disc clamp input
9	VSS			GND
10	NC			Not used
11	CDEJET	O	C	Load motor eject control output
12	CDLOAD	O	C	LOAD motor loading control output
13	CONT	O	C	Servo driver power supply control
14	NC			Not used
15	CDMUTE	O	C	CD mute control output
16	DEEM			Not used
17	ADENA	O	C	A/D reference voltage control output
18-23	NC			Not used
24	VSS			GND
25	DSET			Not used
26	BMUTE			Not used
27-30	NC			Not used
31	BRXEN	I/O	C	Reception enable input/output
32	BSRO	O	C	P-BUS serial pole request input
33	VDCONT	O	C	VD power control output
34	CD5VON	O	C	CD +5V power control output
35	RESET	I		Reset input
36	TXARI	I		VDD
37	CSSENS	I		Flap close sense input
38	BRST	I		P-BUS reset input
39	CMPARI	I		GND
40	VDD			Power supply
41	X2			Crystal oscillator connection pin
42	X1	I		Crystal oscillator connection pin
43	IC			Connect to GND
44	NC			Not used
45	TESTIN	I		Test program start input
46	AVSS	I		A/D GND
47	TEMP	I		Temperature sense input
48	VDSNS	I		VD short detection input
49	EJTSNS			Disc EJECT position detect
50	DSCSNS	I		Disc detect
51	NC			Not used
52	FOK	I		FOK signal input
53	MIRR	I		Mirror detection input
54	LOCK	I		Spindle lock detector input
55	AVDD			Power supply
56	AVREF	I		A/D converter reference voltage
57	XSI	I		Serial data input
58	XSO	O	C	Serial data output
59	XSCK	O	C	Serial clock output
60	XSTB	O	C	CD LSI strobe output
61	XA0	O		Control signal distinguishing data from microcomputer
62	NC			Not used
63	BDATA	I/O	C	P-BUS serial data input/output
64	BSCK	I/O	C	P-BUS serial clock input/output

Format	Meaning
C	C MOS

DEH-59DH,45DH

● Pin Functions (PD4723A)

Pin No.	Pin Name	I/O	Format	Function and Operation
1	RIDRST	O	C	RBDS/IDLOGIC reset output
2	RIDSEL	O	C	RBDS/IDLOGIC select output
3	NC			Not used
4	AVSS			A/D converter ground potential
5	VCAOUT	O		Sub woofer volume control
6	NC			Not used
7	AVREF	I		D/A converter reference voltage
8	KYDT	I		Communication data input
9	DPDT	O	C	Communication data output
10	SWVDD	O	C	Power supply output
11	RIDDI			RBDS/IDLOGIC communication data
12	RIDDO	O	C	RBDS/IDLOGIC communication data output
13	RIDCK	O	C	RBDS/IDLOGIC communication clock output
14	BRST	O	C	P-BUS reset output
15	BRXEN	I/O	C	P-BUS enable input/output
16	BSRQ	I		P-BUS serial pole request input
17	BSIO	I/O	C	P-BUS serial data input/output
18	BSCK	I/O	C	P-BUS serial clock input/output
19	VST	O	C	Strobe pulse output for electronic volume
20	VDT	O	C	Data output for electronic volume
21	VCK	O	C	Clock output for electronic volume
22	DRELAY	O	C	External relay output
23	DRSYS	O	C	Door system select output
24	STOUT	O	C	Starter cut output
25,26	NC			Not used
27	TUNPCK	O	C	PLL IC clock
28	TUNPDO	O	C	PLL IC data output
29	TUNPCE	O	C	PLL IC chip enable
30	TUNPDI	I		PLL IC data input
31	DRSENS			Door open/close sense
32	DLSENS			Door lock sense
33	VSS			GND
34	MUTE	O	C	Mute output
35	FIEOUT	O	C	FIE ON/OFF control output
36	SUBW0	O	N	Sub woofer control 0
37	SUBW1	O	N	Sub woofer control 1
38	DLED	O	N	Alarm LED output
39	TMUTE	O	N	Tuner mute output
40	BMUTE	O	C	Bus mute output
41	ASENBO	O	C	Slave power supply control output
42	ILMPW	O	C	Illumination power supply control output
43	FM	O	C	FM power control output
44	AM	O	C	AM power control output
45	PEE	O	C	Beep tone output
46	TUNPW	O	C	Tuner power control output
47	SYSPW	O	C	System power control output
48	CDPW	O	C	CD power control
49	PCL	O	C	Clock adjustment output
50	LCDPW	O	C	LCD back light power supply control output
51	DIMMER	O	C	Dimmer output
52	SD	I		FM SD input
53	ST	I		FM stereo input
54	TSENS	I		Illumination sense input
55	NC			Not used
56	TX	O	C	IP BUS data output
57	RX	I		IP BUS data input
58	IPPW	O	C	Power supply control output for IP BUS interface IC
59	NC			Not used

Pin No.	Pin Name	I/O	Format	Function and Operation
60	RESET	I		Reset input
61	RIDRDY	I		Ready input
62	BSENS	I		Back up power sense input
63	ASENS	I		ACC power sense input
64	DSENS	I		Grille detach sense
65	MOSENS	I		Sensor input
66	NC			Not used
67	CLKIN	I	C	Clock input
68	VDD			Power supply
69	X2			Crystal oscillator connection pin
70	X1			Crystal oscillator connection pin
71	IC			GND
72	XT2			Not used
73	TESTIN	I	C	Test program mode input
74	AVDD			A/D converter power supply
75	AVREF0			A/D converter standard voltage input
76	SL	I		Signal level input
77	SELO	I		Model select pin
78,79	NC			Not used
80	ADPW	O	C	Control output for analog input reference power

*PD4723A

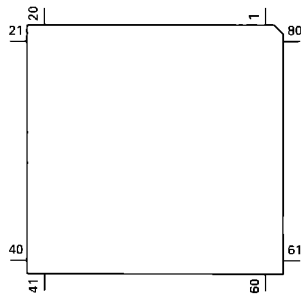

Format	Meaning
C	C MOS
N	Nch open drain

DEH-59DH,45DH

XLA6997FP

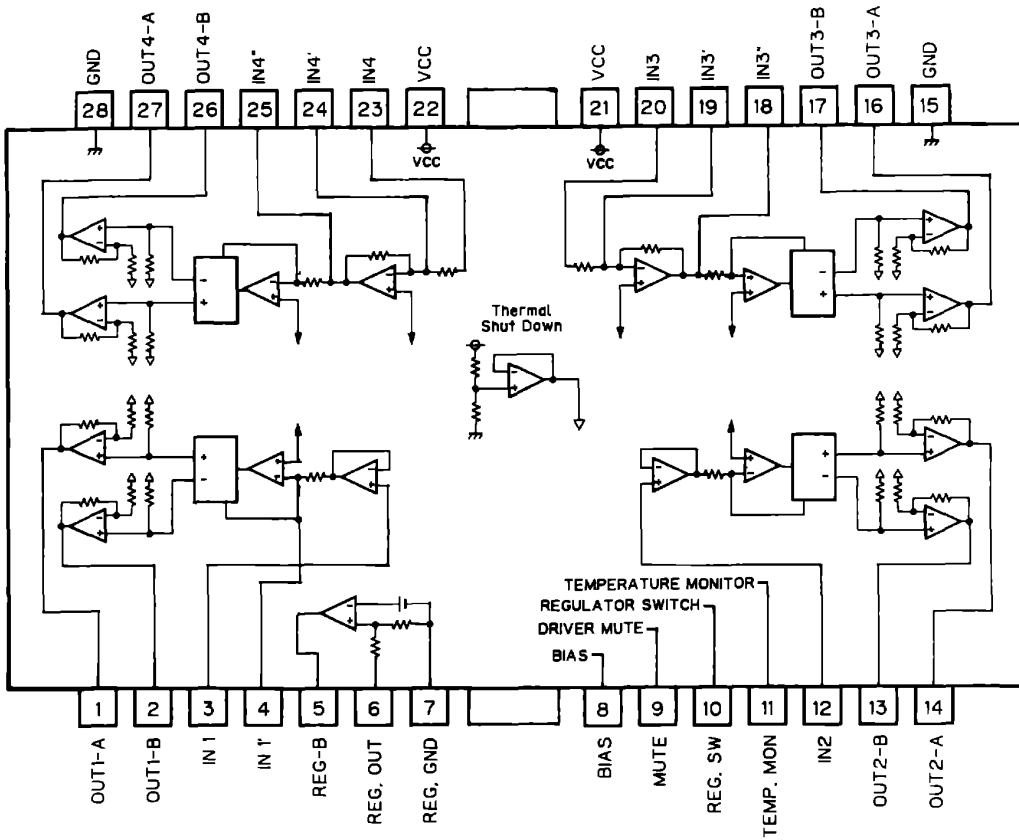

TDA7384A

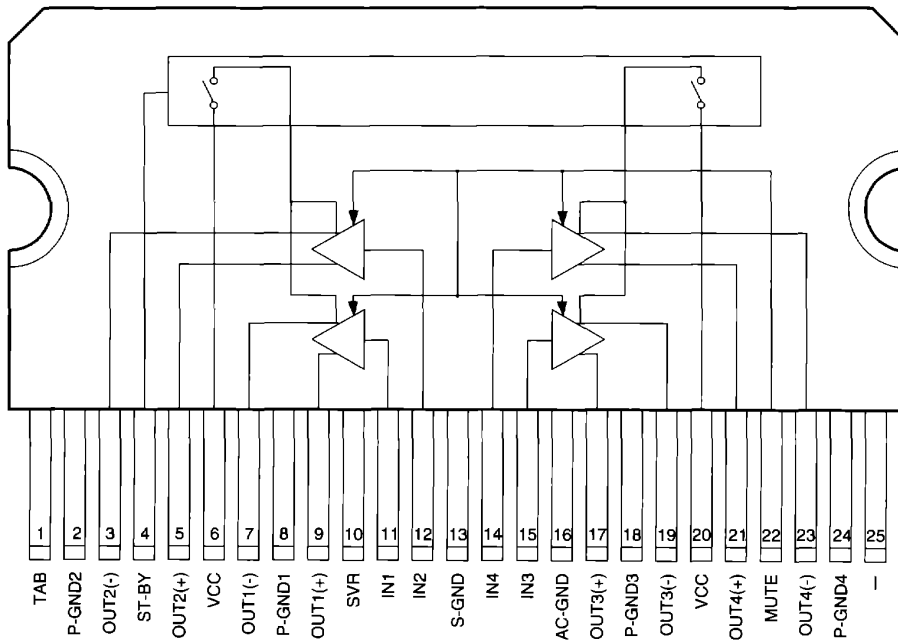

*SN761027DL

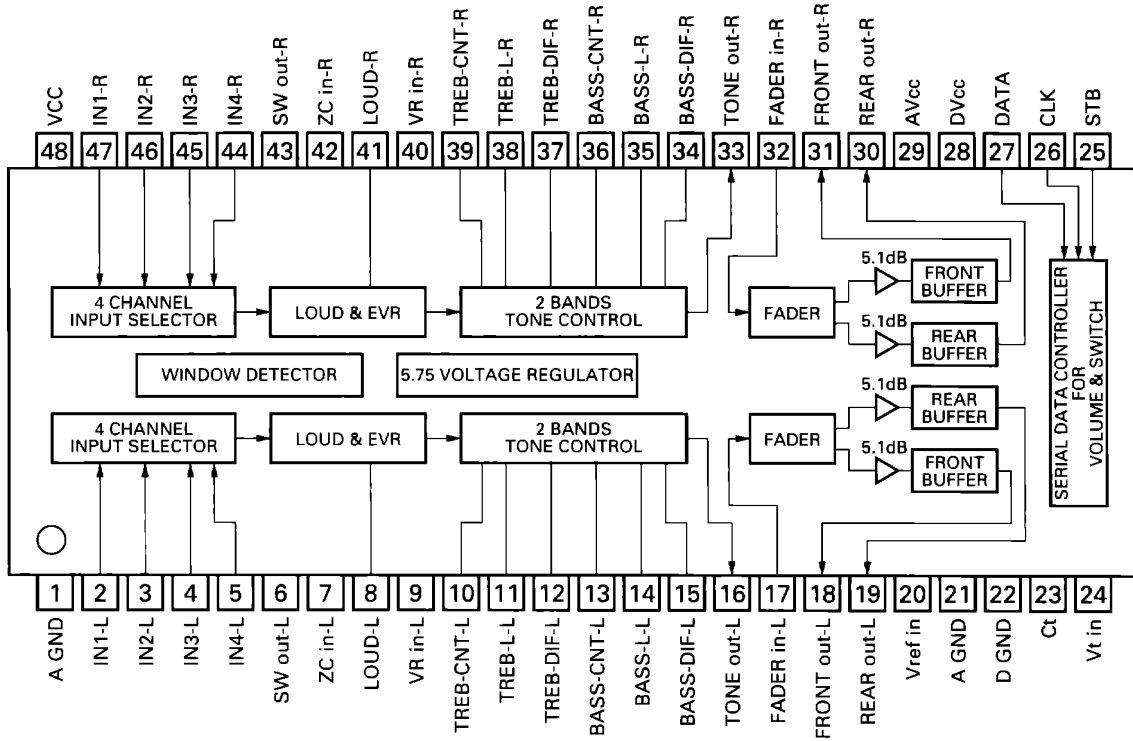

XLA6285FP

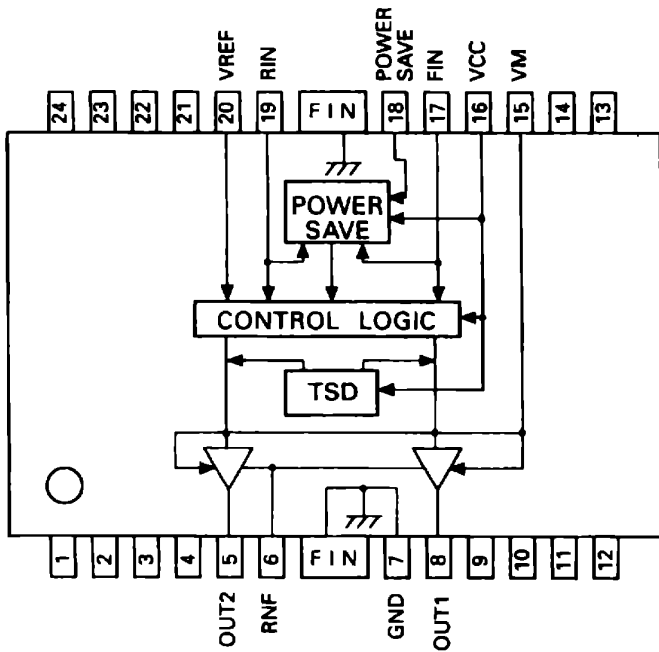

DEH-59DH,45DH

● Pin Functions (PD6197A)

Pin No.	Pin Name	I/O	Function and Operation
1	VSS		GND
2	X1		Crystal oscillator connection pin
3	X0		Crystal oscillator connection pin
4	NC		Not used
5,6	MOD1,0	I	Connect to GND
7	NC		Not used
8	KYDT	O	Display/key data output
9	DPDT	I	Display/key data input
10	REMIN	I	Remote control pulse input
11,12	NC		Not used
13-16	$\overline{KD4-KD1}$	I	Key data input
17-21	$\overline{KS6-KS2}$	O	Key strobe output
22	NC		Not used
23	VDD		VDD
24-73	SEG0-49	O	LCD segment output
74-77	COM3-0	O	LCD common output
78	VLCD	I	LCD voltage input
79,80	V2,V1		Power supply terminal

*PD6197A

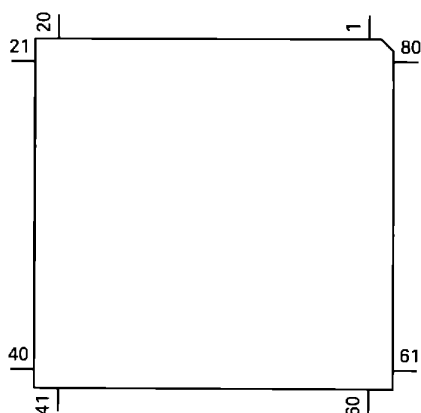

RS-140

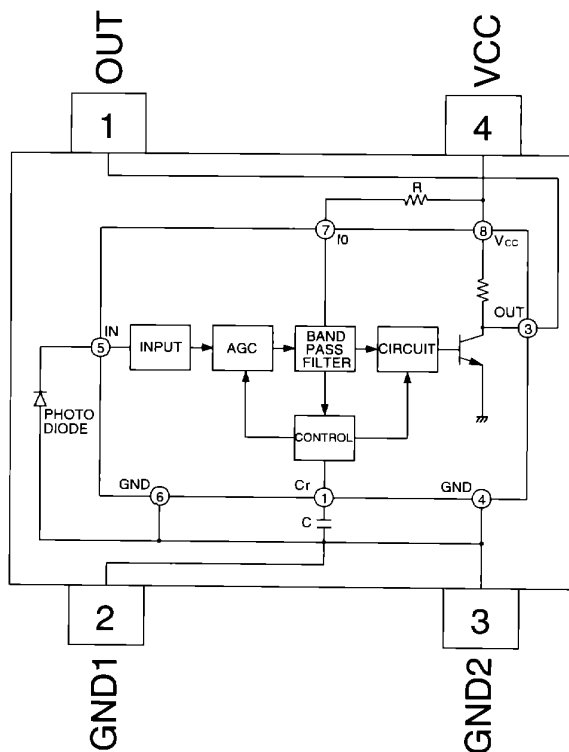

PA4023B

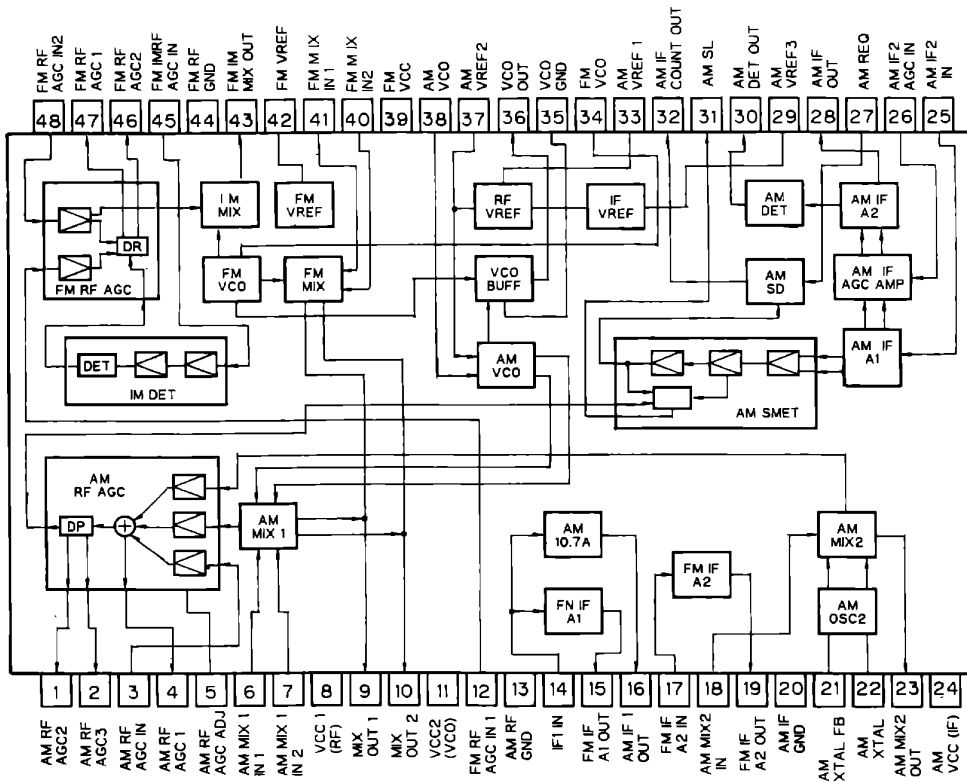

DEH-59DH,45DH

7.1.2 DISPLAY

● CAW1390

COMMON

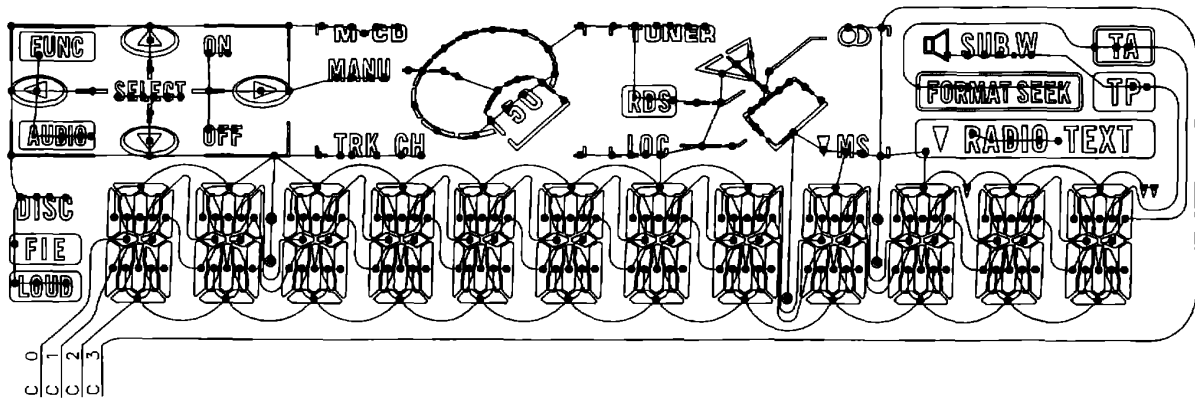

SEGMENT

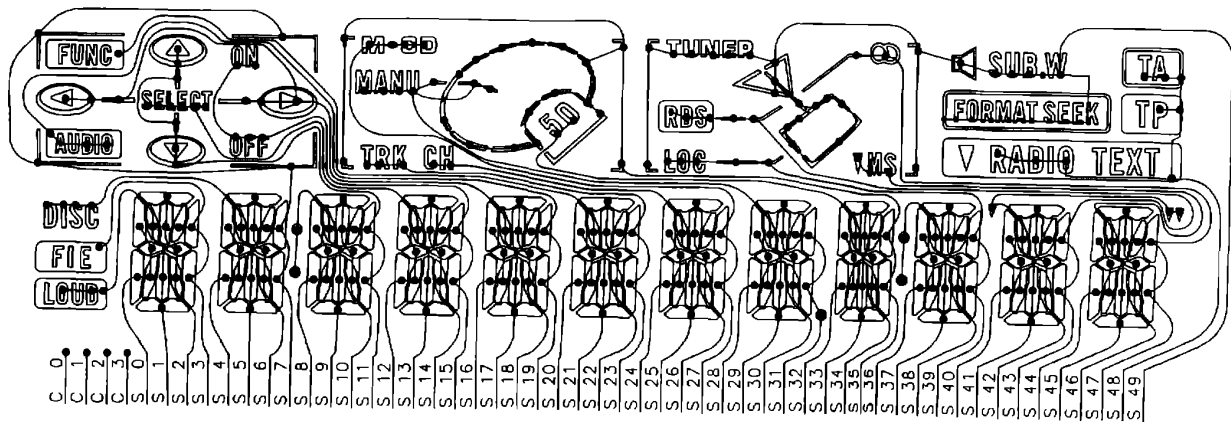

Fig. 27

7.2 DIAGNOSIS

7.2.1 DISASSEMBLY

● Removing the Case

1.Remove the three screws A , and then remove the case.

● Removing the Panel Assy

1.Remove the three screws B.
2.Disconnect the five stoppers C , and then remove the panel assy.

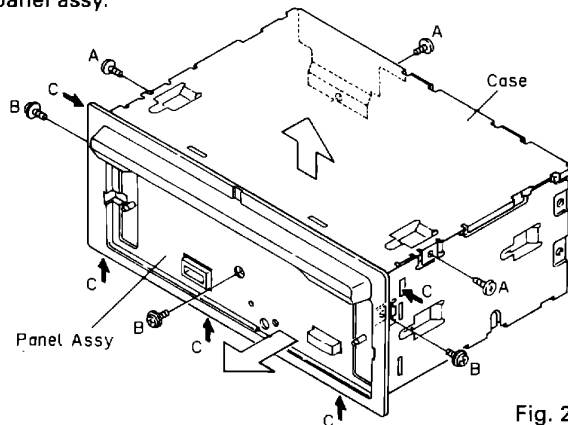

Fig. 28

● Removing the Tuner Amp PCB

1.Remove the six screws.
2.Stretch the four claws , and then remove the tuner amp PCB.

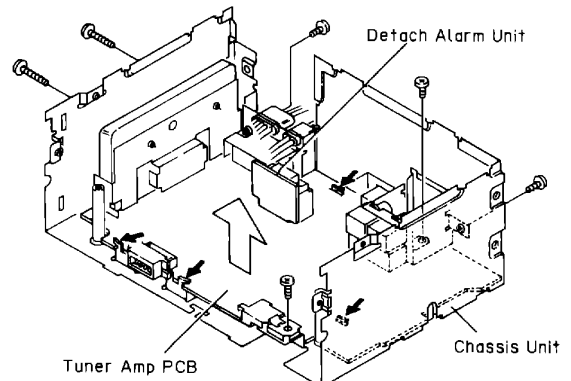

Fig. 30

● Removing the CD Mechanism Module

1.Remove the four screws D.
2.Disconnect the connector indicated by arrow.
3.Remove the CD Mechanism Module.

● Removing the Bracket

1.Remove the four screws E , and then remove the bracket.

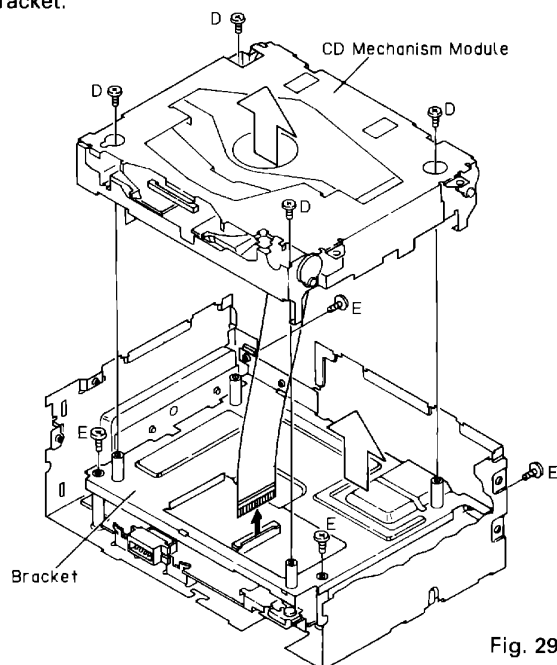

Fig. 29

7.2.2 TEST MODE

● Error Number Indication

If the CD should fail to operate or if an error has taken place during operation the player will enter into the error mode, and the cause of the error will be numerically indicated.

This is aimed at assisting in analysis or repair.

(1) Examples of Display

·ERROR- XX

(2) Error Codes

Error Code	Classification	Description	Cause/Detail
10	ELECTRIC	Carriage home failure	Carriage doesn't move to or from the innermost position →Home switch failed and/or carriage immobile
11	ELECTRIC	Focus failure	Focus failed →Defects, disc upside-down, severe vibration
12	ELECTRIC	Spindle lock failure Subcode failure	Spindle failed to lock or subcode unreadable →Spindle defective, defect, severe vibration
14	ELECTRIC	Mirror failure	Unrecorded CD-R The disc is upside-down, defects, vibration
17	ELECTRIC	Set up failure	AGC protect failed →Defects, disc upside-down, severe vibration
19	ELECTRIC	Set up failure	Tracking error waveform is too unbalanced (>50%) or level is too small →The P.U.unit or tracking error circuitry is N.G.
30	ELECTRIC	Search time out	Failed to reach target address →Carriage/tracking defective and/or defects
A0	SYSTEM	Power failure	Power overvoltage or short circuit detected →Switching transistor defective and/or power abnormal

● New Test Mode(aging operation and setup analysis)

The single CD player plays in normal mode. After being set up, it will display FOK (focus), LOCK (spindle), subcode, sound skip, protection against a mechanical error or the like, occurrence of an error, cause and time of an expiry, if any, (and disk number)

During the setup, the CD software operation status (internal RAM and C-point)is displayed.

(1) How to enter NEW TEST Mode

See the test mode flow chart Page 57.

(2) Relations of keys between TEST and NEW TEST Modes

Keys	Test Mode		New Test Mode	
	Regulator OFF	Regulator ON	PLAY in progress	Error Occurred, Protection Activated
BAND	Regulator ON	Regulator OFF	—	Time of occurrence / cause of error select
>	—	FWD-Kick	TRACK UP / FF	—
<	—	REV-Kick	TRACK DOWN /REV	—
1	—	Tracking close	SCAN	—
2	—	Tracking open	REPEAT	—
3	—	Focus close	RANDOM	—
6	To New Test Mode	Focus Mode Select	AUTO/MANU	—

Operations, such as EJECT, CD ON/OFF, etc. are performed normally

(3) Error Cause (Error Number) Code

Error Code	Classification	Mode	Description	Cause	Detail
40	ELECTRIC	PLAY	FOK=L 100ms	Put out of focus	Scratch, Stain, Vibration, Servo defect, etc...
41	ELECTRIC	PLAY	LOCK=L 100ms	Spindle unlock	
42	ELECTRIC	PLAY	Subcode unacceptable 500ms	Failed to read subcode	
43	ELECTRIC	PLAY	Sound skipped	Last address memory operated	

(4) Indicating an Operation Status During Setup

Status No.	Description	Protection operation
01	Carriage home mode started	None
02	Carriage moving inwards	10-second time out, Home switch failed
03	Carriage moving outwards	10-second time out, Home switch failed
05	Carriage moving outwards	None
11	Setup started	None
12	Spindle turn/Focus search started	None
13	Waiting for focus closure (XSI=L)	Failure to close focus
10,14	Waiting for focus closure (FOK=H)	Failure to close focus
15, 16, 17	Focus closed, Tracking open	Focus disrupted
18	During focus AGC Subcode waiting	Focus disrupted
19	During tracking AGC	Disrupted focus
20	Waiting for MIRR, LOCK or subcode read Carriage closed, SPINDLE=ADAPTIVE	Focus disrupted, MIRR NG, Failure to lock, Failed to read subcode

(5) Example of Display.

· SET UP in progress
8 digits display LCD

TNo.	Min	Sec
11	11	11

· Operation (PLAY, SEARCH, etc.) in progress perfectly identical with that in the normal mode.

· Protection/Error upon occurrence(8 digits display LCD)

(a) Error number indicated

ERROR-xx

Select the display with the BAND key.

(b) Track number and absolute time indicated

TNo.	Min	Sec
10	40	05

7.3 BLOCK DIAGRAM

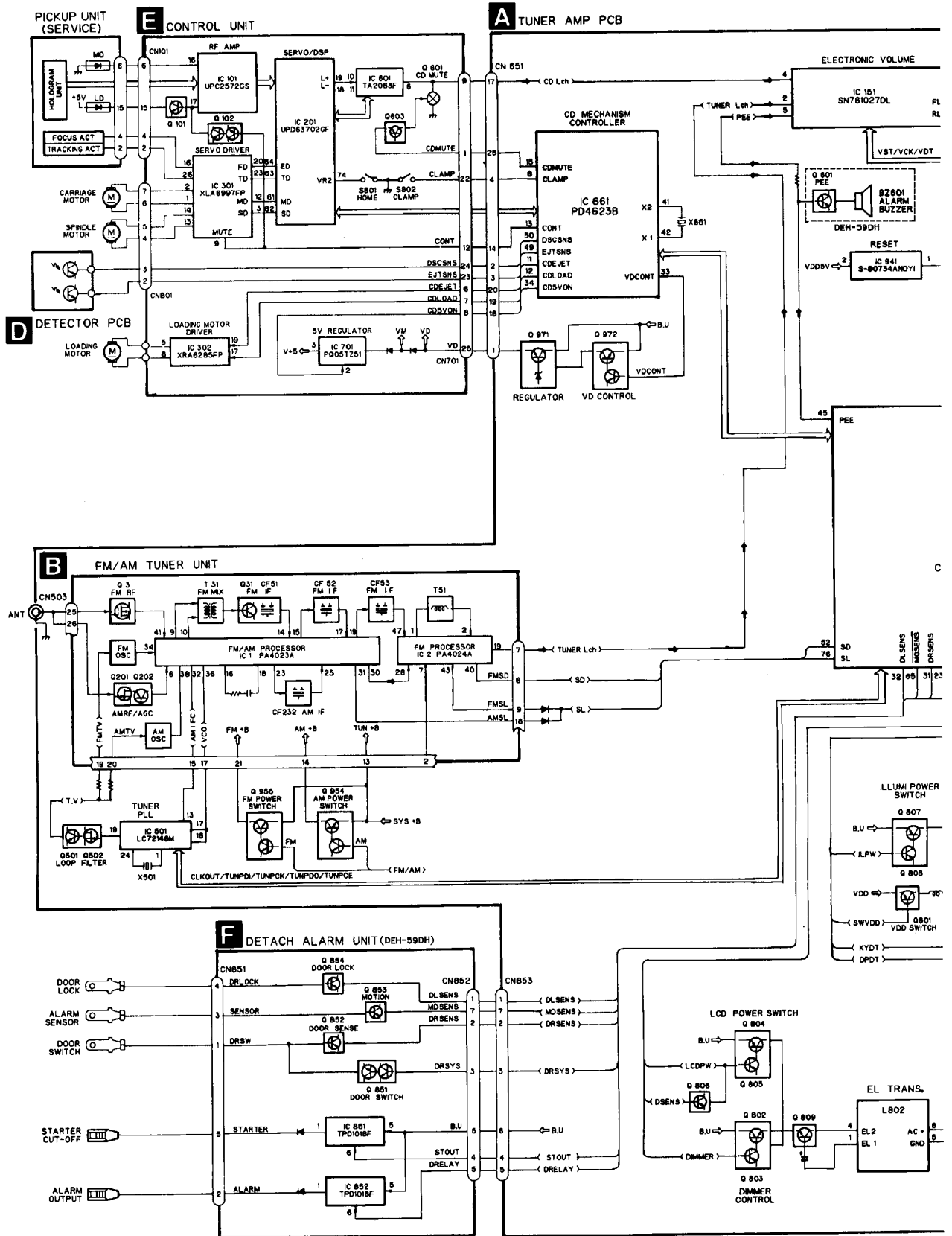

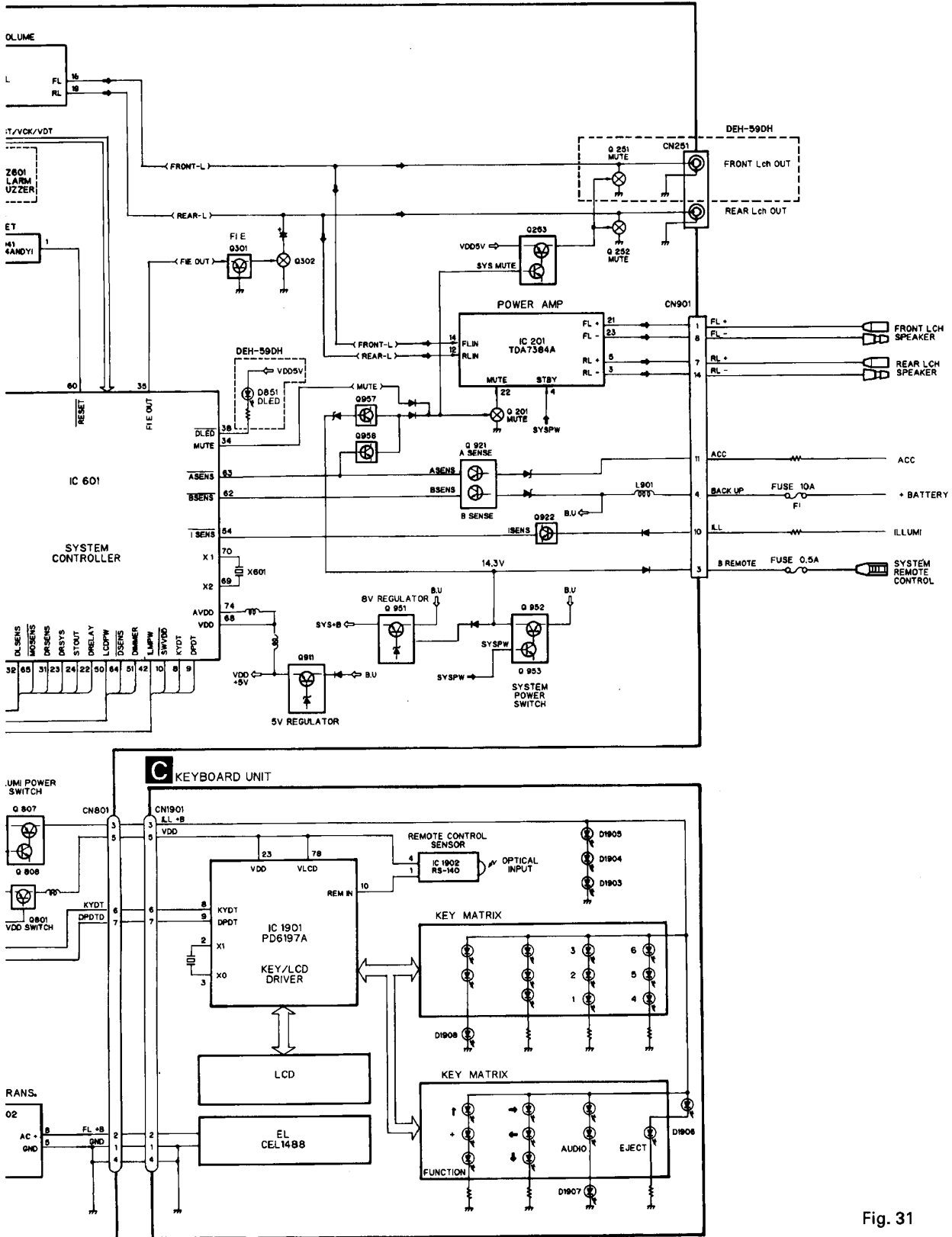

Fig. 31

8. OPERATIONS AND SPECIFICATIONS

Key Finder

■ Head Unit

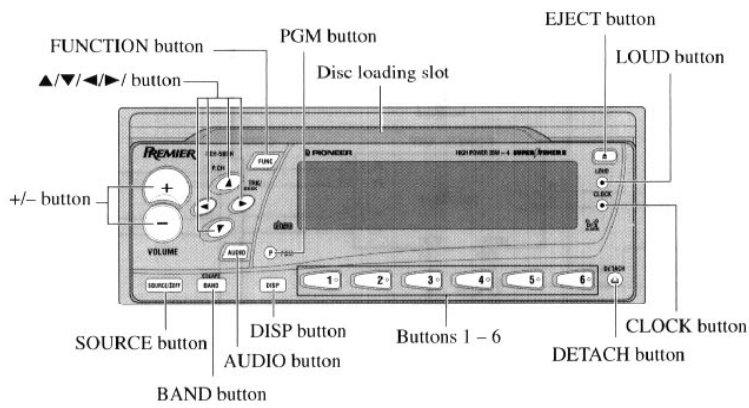

Fig. 32

■ Remote Controller

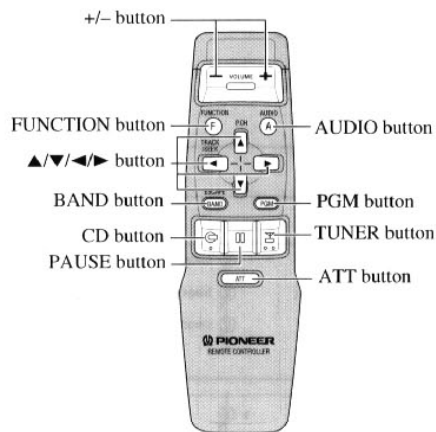
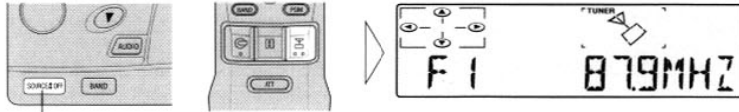

Fig. 33

Tuner Operation

Basic Operation of Tuner

1. Select Tuner.



Each press changes the Source ...

2. Select the desired band.

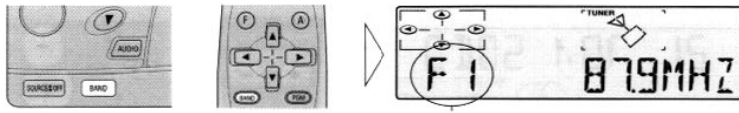

F1 → F2 → F3 → AM

3. Tune the receiver to a higher or lower frequency.

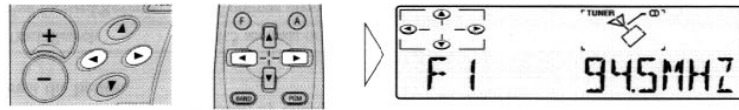

This product's tuner lets you select the tuning by changing the length of the time you press the button.

Manual Tuning (step by step)	0.3 seconds or less
Seek Tuning (automatically)	0.3 – 2 seconds
Manual Tuning (continuously)	2 seconds or more

Note:

- "CD" indicator lights when a stereo station is selected.

Basic Operation

Switching Power ON/OFF

- Select the desired source (such as the tuner).

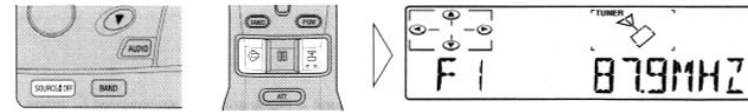

■ Head Unit:

Each press of the SOURCE button selects the desired source in the following order:

Built-in CD player → Tuner

To switch the sources OFF, hold down the SOURCE button for 1 second or more.

■ Remote Controller:

Each press of the CD button selects the desired source in the following order:

Built-in CD player → Sources OFF

Each press of the TUNER button selects the desired source in the following order:

Tuner → Sources OFF

Note:

- The sound source will not change if no disc is set in this unit.

Using the Built-in CD Player

Basic Operation of Built-in CD Player

The built-in CD player plays one standard 12 cm or 8 cm (single) CD at a time. Do not use an adapter when playing 8 cm CD.

1. Insert the disc with the recorded (iridescent) surface down.

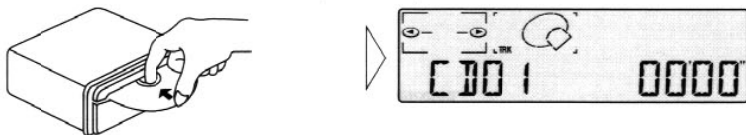

2. Select the desired track (and phrase).

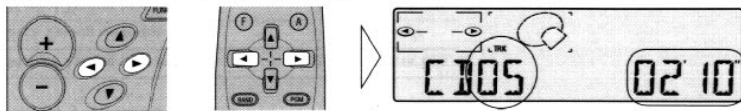

This product's built-in CD player lets you select the track search function or fast-forward/reverse function by changing the length of the time you press the button.

Track Search	0.5 seconds or less
Fast-forward/Reverse	Continue pressing

3. Raise or lower the volume.

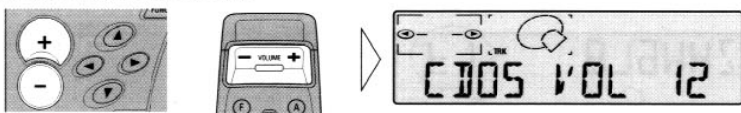

4. Raise or lower the volume.

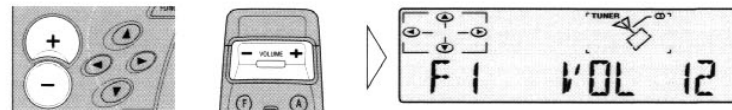

5. Turn the source OFF.

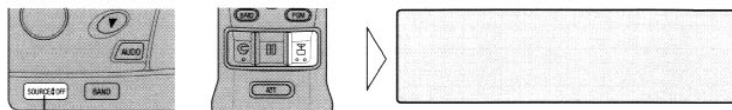

Hold for 1 second

Entering the Function Menu

In this menu you can select tuner functions.

- Select the desired mode in Function Menu.

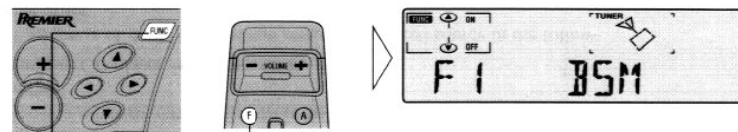

Each press changes the Mode ... Each press changes the Mode ...

Each press of the FUNCTION button selects the mode in the following order:

BSM → LOC

To cancel the Function Menu, press the BAND button.

Note:

- After entering the Function Menu, if you do not perform an operation within about 30 seconds, the Function Menu is automatically canceled.

Built-in CD Player Troubleshooting

Error Message

When problems occur with CD playback, an error message appears on the display. Refer to the table below to identify the problem, then take the suggested corrective action. If the error persists, contact your dealer or your nearest PIONEER Service Center.

Message	Possible cause	Recommended action
ERROR- 11, 12,17, 30	Dirty disc.	Clean the disc.
ERROR- 11, 12, 17, 30	Scratched disc.	Replace the disc.
ERROR- 14	Unrecorded CD.	Check the disc.
ERROR- 10, 11,12, 14 17, 30, A0	Electrical or mechanical or problem. then back	Turn the ignition ON and OFF switch to a different source, to the CD player.

4. Remove the disc.

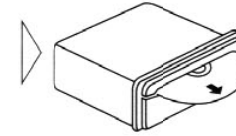
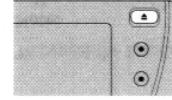

Note:

- The CD function can be turned ON/OFF with the disc remaining in this product. (See Page 75.)
- Discs left partially inserted after ejection may incur damage or fall out.
- If a disc cannot be inserted fully or playback fails, make sure the recorded side is down, push the EJECT button and check the disc for damage before reinserting it.
- If a CD is inserted with the recorded side up, it will be ejected automatically after a few moments.
- If the built-in CD player cannot operate properly, an error message (such as "ERROR-14") appears on the display. Refer to "Built-in CD Player Troubleshooting".

Pause

- Stops playback temporarily or restarts the system.



Note:

- You can also switch the Pause Function ON/OFF in the Function Menu.

Audio Adjustment

Entering the Audio Menu

In this menu, you can adjust sound quality such as fader/balance and bass/treble settings.

- Select the mode you want to adjust in Audio Menu.

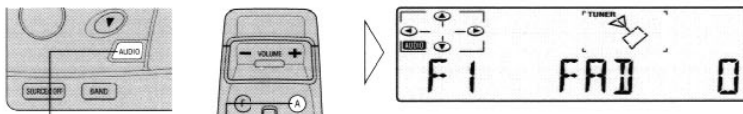

Each press
changes the Mode ...

Each press
changes the Mode ...

Each press of the AUDIO button selects the mode in the following order:
FAD → BAS → TRE → LOUD → FIE

To cancel the Audio Menu, press the BAND button.

Note:

- After entering the Audio Menu, if you do not perform an operation within 30 seconds, the Audio Menu is automatically canceled.

Balance Adjustment

This function allows you to select a Fader/Balance setting that provides ideal listening conditions in all occupied seats.

1. Select the Fader/Balance mode (FAD) in the Audio Menu.
2. Shift the balance progressively to the front or rear speakers.

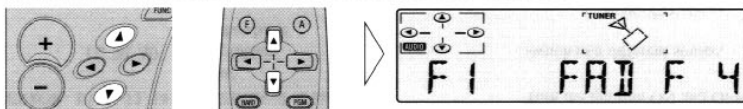

"FAD F15" – "FAD R15" is displayed as it moves from front to rear.

3. Shift the balance to the left or right speaker, respectively.

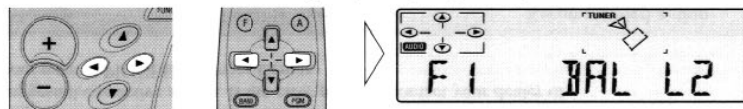

"BAL L9" – "BAL R9" is displayed as it moves from left to right.

To cancel the Audio Menu, press the BAND button.

Note:

- "FAD 0" is the proper setting when 2 speakers are in use.

Bass/Treble Adjustment

This product is equipped with two tone adjustment modes, the Bass (BAS) and Treble (TRE) modes.

1. Select bass mode (BAS) or treble mode (TRE) in the Audio Menu.
2. Increase or decrease the intensity of the bass or treble, whichever is selected.

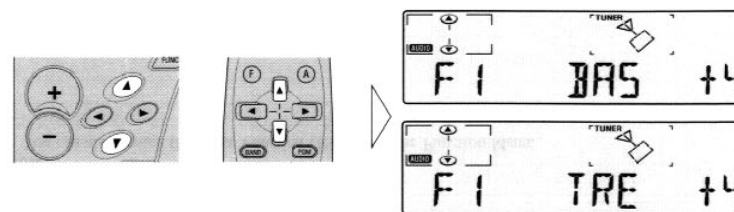

The display shows "+6" – "-6".

3. Repeat steps 1 – 2 above for the other Bass or Treble adjustment.

To cancel the Audio Menu, press the BAND button.

Loudness Adjustment

The Loudness function compensates for deficiencies in the low and high sound ranges at low volume.

- Switch the Loudness function ON.

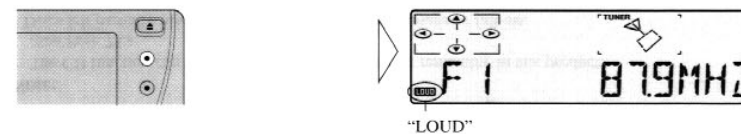

To cancel the Loudness function, repeat the preceding operation.

Note:

- You can also switch the Loudness function ON/OFF in the Audio Menu.

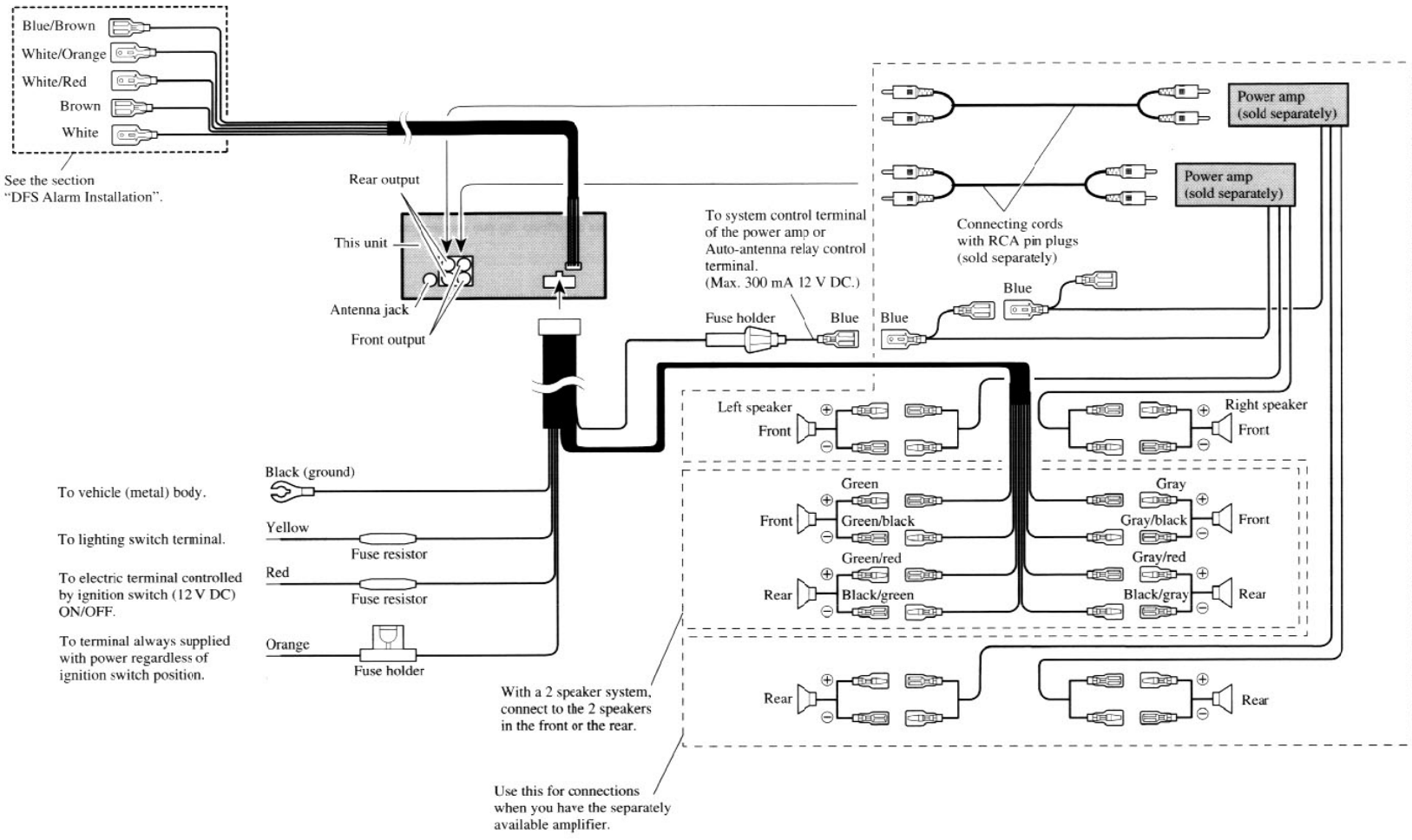

DEH-690DH, 450DH

● DEH-45DH

Specifications**General**

Power source 14.4 V DC (10.8 – 15.1 V allowable)
 Grounding system Negative type
 Max. current consumption 8.0 A
 Dimensions
 (mounting size) 198 (W) × 78 (H) × 135 (D) mm
 [7-3/4 (W) × 3-1/8 (H) × 5-3/8 (D) in.]
 (nose) 190 (W) × 62 (H) × 21 (D) mm
 [7-1/2 (W) × 2-1/2 (H) × 7/8 (D) in.]
 Weight 2.1 kg (4.6 lbs)

Amplifier

Continuous power output is 17 W per channel min. into 4 ohms, both channels driven 50 to 15,000 Hz with no more than 5% THD.
 Maximum power output 35 W × 4
 Load impedance 4 Ω (4 – 8 Ω allowable)
 Preout output level/output impedance 500 mV/1 kΩ
 Tone controls
 (Bass) ±12 dB (100 Hz)
 (Treble) ±12 dB (10 kHz)
 Loudness contour +10 dB (100 Hz), +6.5 dB (10 kHz)
 (volume: –30 dB)

CD player

System Compact disc audio system
 Usable discs Compact disc
 Signal format Sampling frequency: 44.1 kHz
 Number of quantization bits: 16; linear
 Frequency characteristics 5 – 20,000 Hz (±1 dB)
 Signal-to-noise ratio 94 dB (1 kHz) (IHF-A network)
 Dynamic range 90 dB (1 kHz)
 Number of channels 2 (stereo)

FM tuner

Frequency range 87.9 – 107.9 MHz
 Usable sensitivity 11 dBf
 (1.0 μV/75 Ω, mono, S/N: 30 dB)
 50 dB quieting sensitivity 16 dBf (1.7 μV/75 Ω, mono)
 Signal-to-noise ratio 70 dB (IHF-A network)
 Distortion 0.3% (at 65 dBf, 1 kHz, stereo)
 Frequency response 30 – 15,000 Hz (±3 dB)
 Stereo separation 40 dB (at 65 dBf, 1 kHz)
 Selectivity 70 dB (2ACA)
 Three-signal intermodulation
 (desired signal level) 50 dBf
 (two undesired signal level: 110 dBf)

AM tuner

Frequency range 530 – 1,710 kHz
 Usable sensitivity 18 μV (25 dB) (S/N: 20 dB)
 Selectivity 50 dB (±10 kHz)

Note:

- Specifications and the design are subject to possible modification without notice due to improvements.

● DEH-59DH

Specifications**General**

Power source 14.4 V DC (10.8 – 15.1 V allowable)
 Grounding system Negative type
 Max. current consumption 8.0 A
 Dimensions
 (mounting size) 198 (W) × 78 (H) × 135 (D) mm
 [7-3/4 (W) × 3-1/8 (H) × 5-3/8 (D) in.]
 (nose) 190 (W) × 62 (H) × 21 (D) mm
 [7-1/2 (W) × 2-1/2 (H) × 7/8 (D) in.]
 Weight 2.1 kg (4.6 lbs)

Amplifier

Continuous power output is 17 W per channel min. into 4 ohms, both channels driven 50 to 15,000 Hz with no more than 5% THD.
 Maximum power output 35 W × 4
 Load impedance 4 Ω (4 – 8 Ω allowable)
 Preout output level/output impedance 500 mV/1 kΩ
 Tone controls
 (Bass) ±12 dB (100 Hz)
 (Treble) ±12 dB (10 kHz)
 Loudness contour +10 dB (100 Hz), +6.5 dB (10 kHz)
 (volume: –30 dB)

CD player

System Compact disc audio system
 Usable discs Compact disc
 Signal format Sampling frequency: 44.1 kHz
 Number of quantization bits: 16; linear
 Frequency characteristics 5 – 20,000 Hz (±1 dB)
 Signal-to-noise ratio 94 dB (1 kHz) (IHF-A network)
 Dynamic range 90 dB (1 kHz)
 Number of channels 2 (stereo)

FM tuner

Frequency range 87.9 – 107.9 MHz
 Usable sensitivity 11 dBf
 (1.0 μV/75 Ω, mono, S/N: 30 dB)
 50 dB quieting sensitivity 16 dBf (1.7 μV/75 Ω, mono)
 Signal-to-noise ratio 70 dB (IHF-A network)
 Distortion 0.3% (at 65 dBf, 1 kHz, stereo)
 Frequency response 30 – 15,000 Hz (±3 dB)
 Stereo separation 40 dB (at 65 dBf, 1 kHz)
 Selectivity 70 dB (2ACA)
 Three-signal intermodulation
 (desired signal level) 50 dBf
 (two undesired signal level: 110 dBf)

AM tuner

Frequency range 530 – 1,710 kHz
 Usable sensitivity 18 μV (25 dB) (S/N: 20 dB)
 Selectivity 50 dB (±10 kHz)

Note:

- Specifications and the design are subject to possible modification without notice due to improvements.