

203

# SERVICE MANUAL

**AKAI TAPE RECORDER**

**MODEL X-360**

ALSO APPLICABLE FOR MODEL X-360D

# I. SPECIFICATIONS

<b>POWER SUPPLY</b>	: AC 100 to 240 V, 50 or 60 Hz	<b>MAIN MOTOR</b>	: Hysteresis Synchronous 3 speeds (2-4-8 pole) motor. Condenser Capacity 3 $\mu$ F (50 Hz), 2 $\mu$ F (60 Hz) Revolutions : 3,000-1,500-750 r.p.m. (50 Hz) 3,600-1,800-900 r.p.m. (60 Hz)
<b>RECORDING SYSTEM</b>	: In-line 4-track stereo, monaural recording by using Cross-field Bias Head.	<b>REEL MOTOR</b>	: Two 6-pole eddy current outer-rotor motors Revolutions : 930 r.p.m. at 50 Hz, 100 V 1,120 r.p.m. at 60 Hz, 120 V
<b>TAPE SPEED</b>	: 1-7/8, 3-3/4, 7-1/2 and 15 ips.	<b>HEADS</b>	
<b>TAPE SPEED DEVIATION</b>	: Within $\pm 0.5\%$ at 7-1/2 ips Within $\pm 1.0\%$ at 3-3/4 ips Within $\pm 1.0\%$ at 1-7/8 ips	<b>PLAYBACK HEAD</b>	: In-line 4-track stereo and monaural Impedance . . . 5,000 ohms at 1,000 Hz Gap . . . 2 microns
<b>WOW AND FLUTTER</b>	: Less than 0.10% r.m.s. at 7-1/2 ips Less than 0.13% r.m.s. at 3-3/4 ips Less than 0.25% r.m.s. at 1-7/8 ips	<b>RECORDING HEAD</b>	: In-line 4-track stereo and monaural Impedance . . . 45 ohms at 1,000 Hz Gap . . . 2 microns
<b>FREQUENCY RESPONSE</b>	: 30 to 21,000 Hz $\pm 3$ dB at 7-1/2 ips 30 to 18,000 Hz $\pm 3$ dB at 3-3/4 ips 40 to 9,000 Hz $\pm 4$ dB at 1-7/8 ips	<b>ERASE HEAD</b>	: In-line 4-track stereo and monaural Impedance . . . 380 ohms at 100 KHz Gap . . . 0.4 mm
<b>SIGNAL TO NOISE RATIO</b> (at Line Output)	: Greater than 48 dB at 7-1/2 ips Greater than 45 dB at 3-3/4 ips Greater than 48 dB at 1-7/8 ips	<b>CROSS-FIELD BIAS HEAD</b>	: In-line 4-track stereo and monaural Impedance . . . 430 ohms at 100 KHz Gap . . . 0.4 mm
<b>TOTAL HARMONIC DISTORTION</b> (at Line Output, 1,000 Hz 0 VU Rec/PB)	: Within 1.7% at 7-1/2 ips Within 3.0% at 3-3/4 ips Within 3.0% at 1-7/8 ips	<b>INTERNAL SPEAKERS</b>	: 2 4-inch Round Speakers Nominal Power Input . . . 3 W, 16 ohms
<b>RECORDING INPUTS</b>		<b>TRANSISTORS USED</b>	: 15 2SC458LG <sup>(B)</sup> / <sup>(C)</sup> 15 2SC372 1 2SC828 <sup>(J)</sup> 3 2SC538A <sup>(Q)</sup> 2 2SC650 <sup>(B)</sup> 1 2SC728 1 2SB75A 1 2SB77A <sup>(B)</sup> 4 2SD157 1 2SD147 6 2SC828R 2 2SC538RQ 4 2SC696EB 4 2SD130R
<b>MICROPHONE</b>	: Above 0.7 mV		} X-360D (without Main Amplifier) 44 ca.
<b>LINE INPUT</b>	: Above 70 mV Impedance . . . 166 K ohms		
<b>DIN INPUT</b>	: High : 70 mV 166 K ohms Low : 7 mV 16 K ohms		} Main Amplifier 16 ea.
<b>OUTPUTS</b>			
<b>LINE OUTPUT</b>	: Required Load Impedance : more than 50,000 ohms 1.23 V (+4 db $\pm 1.5$ db) at 7-1/2 ips 1.03 V (+2.5 db $\pm 1.5$ db) at 3-3/4 ips 0.82 V (+0.5 db $\pm 1.5$ db) at 1-7/8 ips	<b>DIODE USED</b>	
<b>POWER OUTPUT:</b>	External Speaker Jack More than 10 W at 8 ohms Non-inductive resistance		
<b>NOISE</b>	: Less than 5 mV at 8 ohms at External Speaker Jack (Volume Control at "Minimum" position)		
<b>FAST FORWARD AND REWIND TIME</b>	: 75 seconds for a full 1,200 foot tape at 50 Hz 60 seconds for a full 1,200 foot tape at 60 Hz		
<b>CROSS-TALK</b>	: Less than -70 dB (Monaural) Less than -43 dB (Stereo)		
<b>ERASE RATIO</b>	: More than 70 dB		
<b>INSULATION DURABILITY</b>	: 500 V AC for more than one minute duration		
<b>BIAS FREQUENCY:</b>	100 KHz		

## II. MEASURING METHOD

### TAPE SPEED DEVIATION

1. Method involving use of pre-recorded tape.

Playback on the tape recorder to be tested tape pre-recorded at 1,000 Hz  $\pm$  0.1% for measuring tape speed deviation. Connect the appropriate output to a frequency counter meter in order to measure the tape speed deviation from the resulting deviation of the measured frequency.

2. Method involving use of timing tape  
(designed for tape speed measurement)

This method utilizes a timing tape marked at intervals of 7-1/2". The running time of the tape over 60 marked section is measured in order to calculate the deviation of the tape speed. In applying this method, however, it should be born in mind that the timing tape stretch or contract, measurement error is inevitable, so that it is necessary to measure the total length of the tape in advance.

### WOW AND FLUTTER

Playback the 3,000 Hz pre-recorded tape whose wow and flutter level is guaranteed to be smaller than 0.07% for measurement by means of a wow meter. It is also possible for a 3,000 Hz sine wave to be recorded and played for measurement by means of the wow meter. In this case, however, the wow meter indicates a value as much as twice the value given in the specifications on the first page.

### FREQUENCY RESPONSE

RECORD:

- 1) Give a sine wave of 1,000 Hz to the Line Input of the recorder to be tested through an attenuator from an audio frequency generator.
- 2) Push the "Source Button" and adjust the line input volume so that the VU meter needle indicates "0" VU.
- 3) Under the condition described in (2), lower the input level 20 db by means of the attenuator.
- 4) Connect a microphone to the Microphone Input. Push the tape speed selector in 7-1/2" position.
- 5) Start recording. Control the microphone input level and the spot frequency in the range of 30 Hz to 25,000 Hz from the audio frequency generator and record by talking.

\* Remarks: After announcing the frequency of each point, the the microphone volume should immediately be rotated back to minimum.

PLAYBACK:

- 6) Push the "Tape Monitor Button" and "Forward Button".
- 7) Set the Tape Speed Selector in 7-1/2" position.
- 8) Connect a Vacuum Tube Volt Meter to the line output jack (V.T.V.M. with milli volt scale).
- 9) Playback the recorded tape.
- 10) Playback the recorded spot frequencies and make a memo of output level and plot the value on a graph.

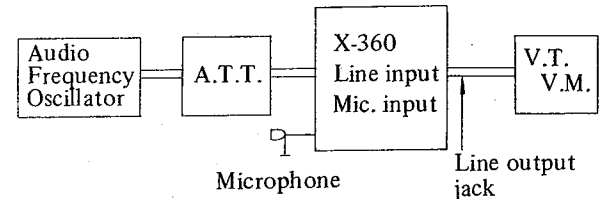

### TOTAL HARMONIC DISTORTION FACTOR

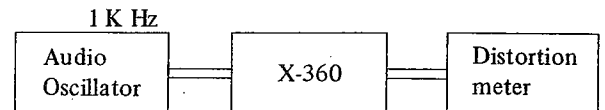

Connect the measuring instrument as shown above, and record the 1,000 Hz sine wave at "0" VU. Playback the resultant signal and measure the overall distortion factor. Measure the noise level of the tape recorder with the tape removed; connect the audio oscillator directly to the distortion meter for measurement of the distortion factor of the oscillator.

The required distortion factor may be obtained from the results of the above measurement by the following formula:

$$d_0 = d - d_1 - d_2$$

where,  $d_0$  = Required  
 $d$  = Overall distortion factor  
 $d_1$  = Noise level  
 $d_2$  = Distortion factor of the oscillator

(Note: New tape of particularly good quality should be used for measurement of the distortion factor).

### SIGNAL TO NOISE RATIO

Set the tone Switch on "Flat" position and Playback a tape containing a 250 Hz sine wave recorded at "0" VU level on a standard recorder. Connect a high sensitivity V.T.V.M. to the line output jack and measure its output.

Then remove the tape and measure the noise level under the same conditions. Convert into decibels each of the measured values.

## POWER OUTPUT

Playback a tape containing a sine wave of 1,000 Hz recorded at 0 VU on a standard recorder. Measure the voltage at the output of the recorder to be tested when terminated with 8 ohms resistance.

Then use the following formula:

$$P = \frac{E^2}{R} \quad \left\{ \begin{array}{l} P = \text{Desired output (watts)} \\ E = \text{Measured voltage (R.M.S.)} \\ R = 8 \end{array} \right.$$

## CROSS TALK (Cross talk between the tracks)

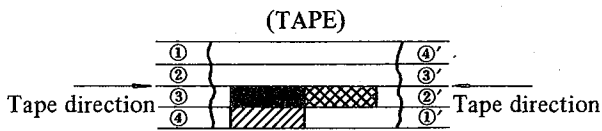

As shown in the figure, first record a 1,000 Hz sine wave on track No. 3 at + 3 VU level. Next, remove the 1,000 Hz input signal and record under a non-input condition. Then, playback the tape on track No. 3 and No. 1 (reversed condition of tape) through the 1,000 Hz B.P.F. (Band Pass Filter, Sensitivity . . . 1:1) and obtain a ratio between the two from the following formula.

$$C = 20 \log \frac{E_0}{E_2 - E_1} \text{ (db)}$$

C = Desired cross talk ratio (db)

$E_0$  = 1,000 Hz signal output level

$E_2$  = 1,000 Hz cross talk output level

$E_1$  = Non-input signal record level



### III. CONTROL LOCATIONS

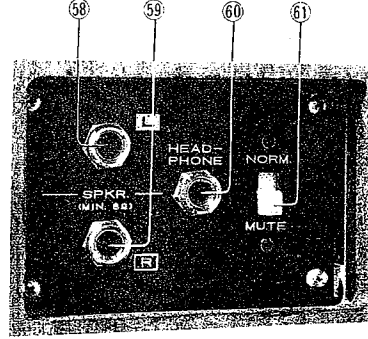
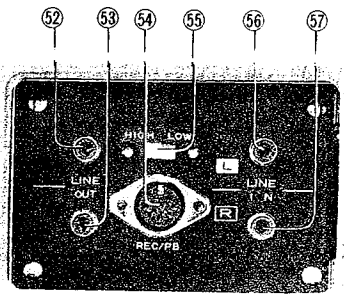
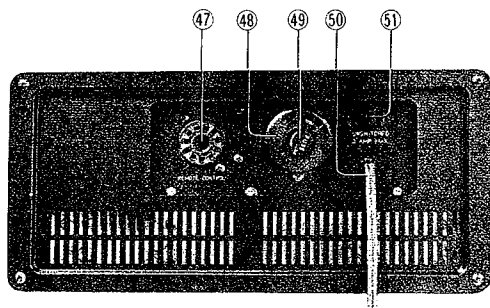
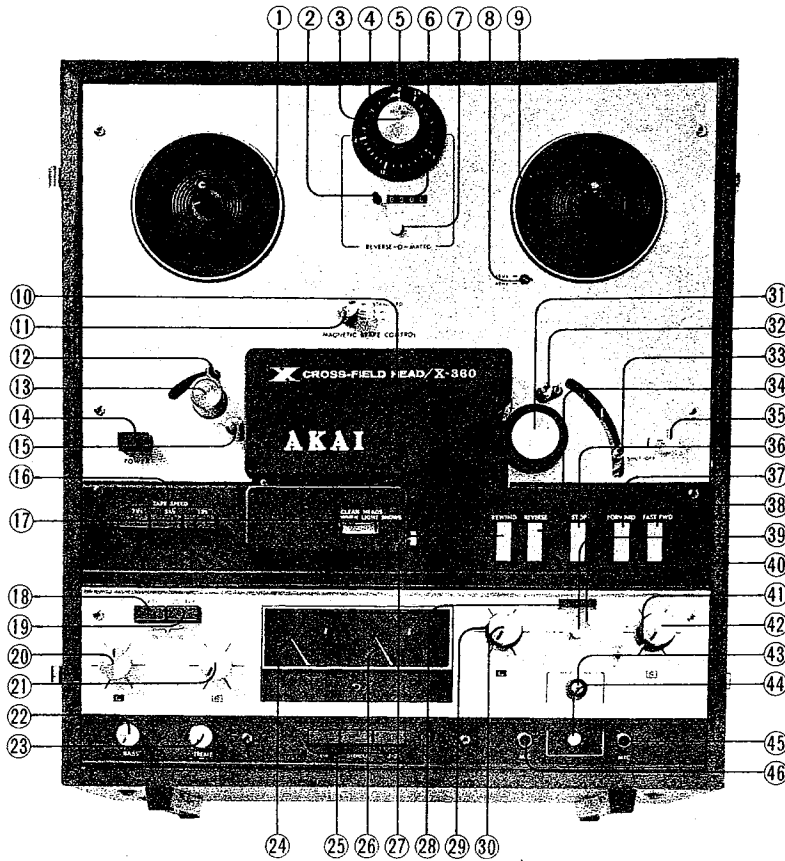

- ① Supply Reel Shaft
- ② Reset Button
- ③ Set Dial
- ④ Tape Count Meter
- ⑤ Tape Count Scale
- ⑥ Tape Counter
- ⑦ REVERSE-O-MATIC Set Button
- ⑧ Cycle Change Switch
- ⑨ Take-up Reel Shaft
- ⑩ Head Cover
- ⑪ Brake Control
- ⑫ Tension Arm
- ⑬ Impedance Roller
- ⑭ Power Switch
- ⑮ Tape Cleaner
- ⑯ Tape Speed Selectors
- ⑰ Indicator Lamp of Dust Minder
- ⑱ "TAPE" Button
- ⑲ "SOURCE" Button
- ⑳ Volume Control (Left)
- ㉑ Volume Control (Right)
- ㉒ Bass Control
- ㉓ Treble Control
- ㉔ VU Meter (Left)
- ㉕ Track Selectors
- ㉖ VU Meter (Right)
- ㉗ Rewind Button
- ㉘ Record Indicator Lamp
- ㉙ Line Record Level Control (Left)
- ㉚ Microphone Record Level Control (Left)
- ㉛ Pinch Wheel (Roller)
- ㉜ Reverse Pins
- ㉝ Take-up Tension Arm
- ㉞ Reverse Button
- ㉟ Shut off Switch
- ㊱ Stop Button
- ㊲ Forward Button
- ㊳ Fast Forward Button
- ㊴ Record Interlock Button
- ㊵ Record Safety Lock
- ㊶ Line Record Level Control (Right)
- ㊷ Microphone Record Level Control (Right)
- ㊸ COMPUT-O-MATIC Record Level Indicator
- ㊹ COMPUT-O-MATIC Set Button
- ㊺ Microphone Jack (Right)
- ㊻ Microphone Jack (Left)
- ㊼ Remote Control Socket
- ㊽ Voltage Selector
- ㊾ Fuse Post
- ㊿ AC Cord
- 1 AC Outlet
- 2 Line Output Jack (Left)
- 3 Line Output Jack (Right)
- 4 DIN Jack
- 5 HIGH/LOW Change Switch
- 6 Line Input Jack (Left)
- 7 Line Input Jack (Right)
- 8 External Speaker Jack (Left)
- 9 External Speaker Jack (Right)
- 0 Stereo Headphone Jack
- 1 Speaker Switch

## IV. DISMANTLING OF TAPE TRANSPORT UNIT & AMPLIFIERS



- 1) Remove CONTROL KNOBS (Volume, Line Record Level, Microphone Record Level, Bass & Treble which are marked (A) to (H) ) with taking off their RETAINING SCREWS by using a Philips-head screw driver.

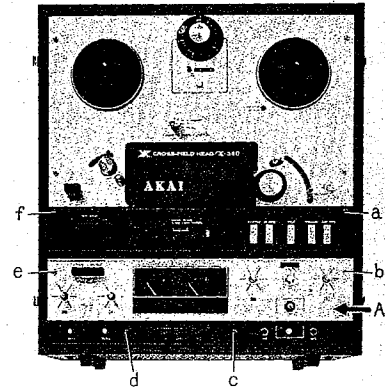

- 2) Remove RETAINING SCREWS (marked (a) to (f) ) by using a Philips-head screw driver and remove the AMPLIFIER COVER PANEL (A).

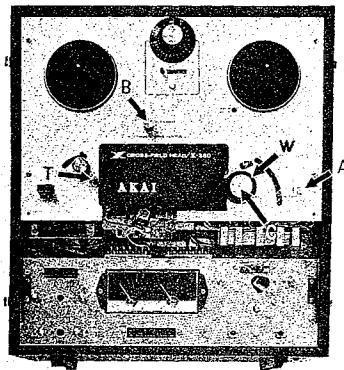

- 3) Remove KNOBS (BRAKE CONTROL & SHUT OFF SWITCH marked (A) and (B) ) with taking off the RETAINING SCREWS. PINCH WHEEL (W) is removed with taking off the PINCH WHEEL CAP (C) by hand. Remove TAPE CLEANER (T) by using minus head driver.

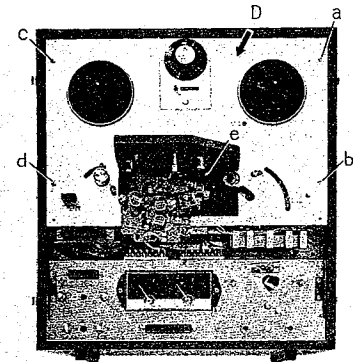

- 4) Remove SCREWS (marked (a) to (d) ) by using a Philips-head screw driver, and NUT (e) by using a box head driver, and remove the DECK COVER PANEL (D) along with MAIN HEAD COVER.

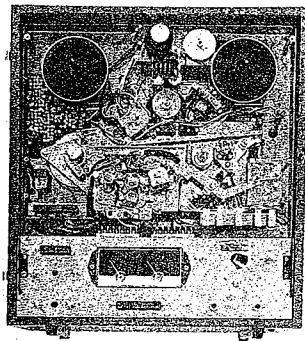

- 5) This picture shows all top cover panels removed making front mechanism control adjustment accessible.

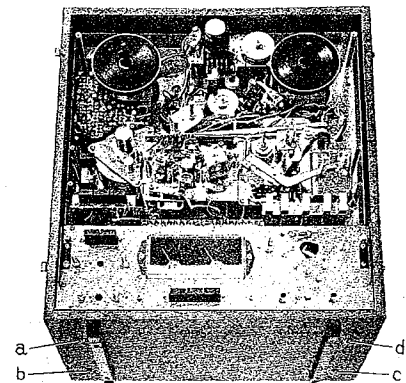

- 6) Remove RETAINING SCREWS (marked (a) to (d) ) by using a Philips-head screw driver.

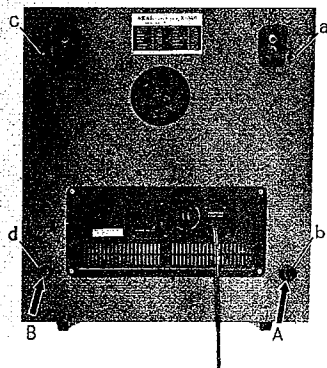

7) Remove RETAINING SCREWS (marked (a) to (d) ) by using a Philips-head screw driver and remove the RUBBER FEET (A) and (B).

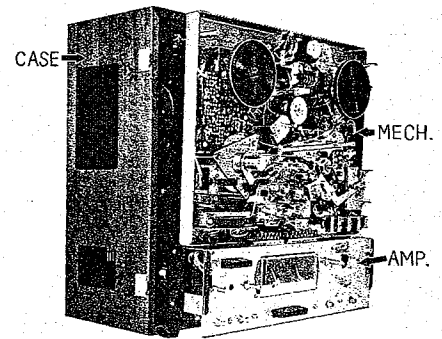

8) This picture shows all components removed from the case. The upper part houses the mechanism, the lower part the amplifiers.

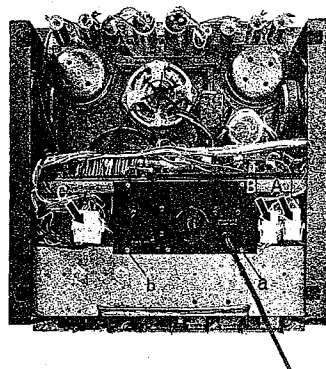

9) Carefully disconnect PLUGS (marked (A) to (C) ) and remove RETAINING SCREWS (marked (a) and (b) ).

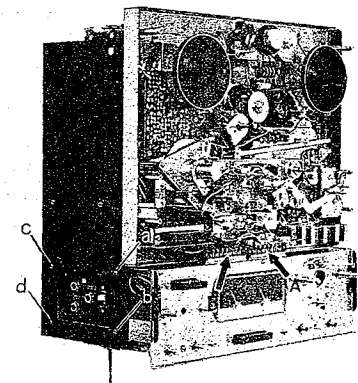

10) Carefully disconnect PLUGS (marked (A) and (B) ) and remove SELF TAPPING SCREWS (marked (a) to (d) ) by using a Philips-head screw driver.

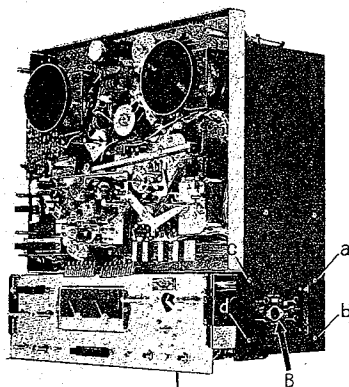

11) Remove SELF TAPPING SCREWS (marked (a) to (d) ) by using a Philips-head screw driver. The machine may then be separated into two parts.

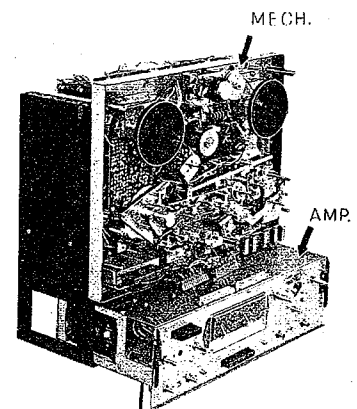

12) The amplifiers can now be removed.

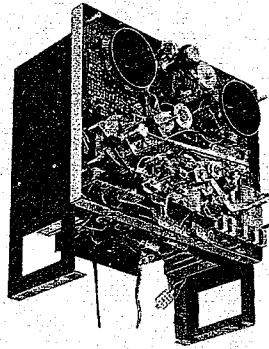

- 13) This picture shows the entire mechanical assembly. Any mechanical adjustment is now possible.

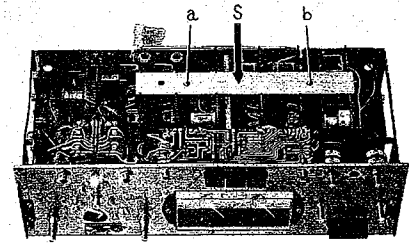

- 14) This picture shows the entire amplifier assembly, including PRE-AMPLIFIER & MAIN AMPLIFIER CARD BLOCKS. Remove RETAINING SCREWS ((a) and (b)) in order to remove the supporting plate (S).

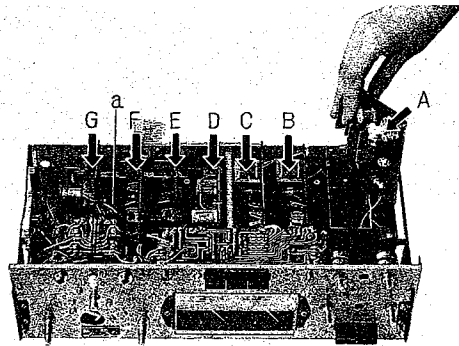

- 15) CARDS (marked from (A) to (F)) are now available to be withdrawn. COM DETECTOR CARD BLOCK (G) will be withdrawn with removing screw (a) by using a Philips-head screw driver.

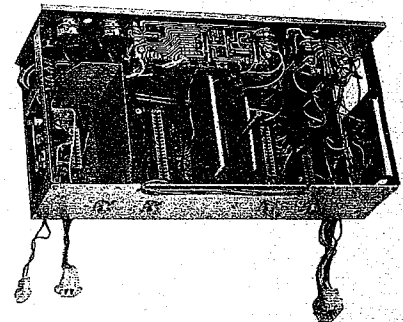

- 16) This picture shows the AMPLIFIER CHASSIS after all card blocks have been removed.



## V. MAGNETIC HEADS ADJUSTMENT

### 1. Adjustment of Magnetic Heads

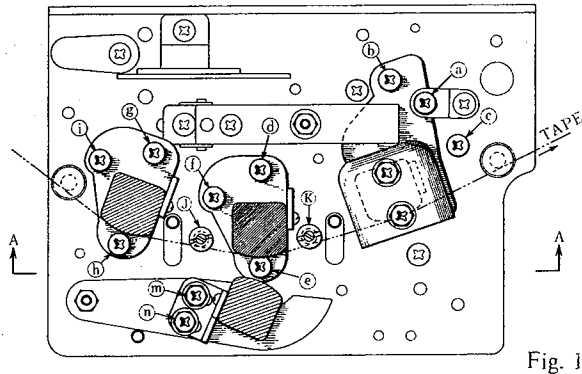

Fig. 1

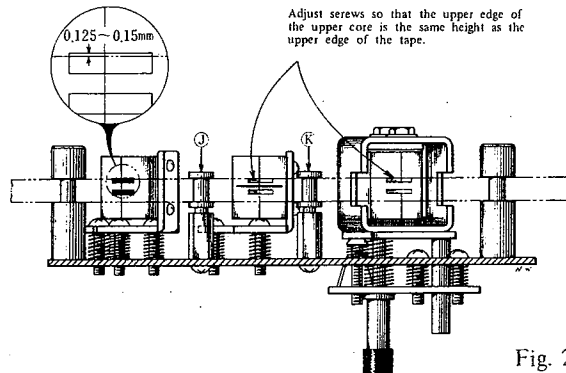

Fig. 2

Since adjustment of the Heads critically affects tape recorder performance, it is essential that Heads be carefully adjusted with precision measuring equipment and a suitable recorded tape.

#### 1.1 Adjustment of Head Height (See Figures 1 and 2)

Whenever replacing the Head Assembly, adjust the Tape Guides (J) and (K) so that they do not contact the edge of the tape, then proceed with Head height adjustment.

##### 1) Playback Head

To adjust, turn Screw (a) (Figure 1) during "Normal Play" position so that the upper edge of the upper core of the Playback Head is the same height as the upper edge of the tape. Adjust by turning Screw (b) (Figure 1) during "Reverse Play" position so that the lower edge of the lower core of the Playback Head is the same height as the lower edge of the tape.

##### 2) Recording Head

Adjust with Screws (d), (e) and (f) (Figure 1) so that the upper edge of the upper core is the same height as the upper edge of the tape.

##### 3) Erasing Head

Adjust Screws (g), (h) and (i) (Figure 1) so that

the upper edge of the upper core is 0.125 to 0.15 mm higher than the upper edge of the tape. (Precaution)

In adjusting Head Height, make sure that the front of the Head is at right angles to the Chassis and that the upper and lower part of the Head firmly contact the tape.

#### 1.2 Adjustment of Azimuth Alignment

##### 1) Playback Head

Use a Pre-recorded tape (16 KHz, 7-1/2 ips), and connect a highly sensitivity V.T.V.M. to the line output jack. Adjust Screw (C) (Figure 1) so that line output voltage is maximum.

##### 2) Recording Head

Connect an Audio Oscillator to the line input jack and record 16 KHz Signals at a -10db recording level and depress the Monitor "TAPE" Button. Adjust Screw (f) (Figure 1) so that the indicated V.T.V.M. value applied to the line output jack is maximum.

##### 3) Erasing Head

Visually check to assure that the centerline of the Erasing Head, is at right angles to the Head Chassis.

##### 4) Bias Head

Loosen Screws (m) and (n) (Figure 1), adjust angulation and clearance of the Bias and Recording Heads, as subsequently described in paragraph 2-5 (Adjustment of Recording Equalization (Balance) Characteristics).

## VI. AMPLIFIER ADJUSTMENT

### 1. PLAYBACK OUTPUT LEVEL (Pre-amplifier) ADJUSTMENT

- Connect a High-sensitivity V.T.V.M. to the Line Output Jack
- Set the Tape Speed Selector Switch to the "7-1/2" position.
- Playback a 250 Hz pre-recorded tape.
- Adjust the VR29-1 (semi-fixed resistor, 50 K-B) of the Pre-amplifier so that Line Output Voltage indicates 1.228 V (+4 dbm).

### 2. VU METER SENSITIVITY ADJUSTMENT

After the above adjustment, adjust the VR26-1 (semi-fixed resistor 2 K-B) of Chassis Print Board (RD-526) so that the VU meter needles indicate exactly 0 VU, denoted by dot.

### 3. MAIN AMPLIFIER ADJUSTMENT

- As shown in Fig. 1, connect the AM Meter (100 mA–150 mA scale) and a resistor ( $8\Omega$  20W) to the External Speaker Jack.
- Set the Main Amplifier Volume Control to minimum so that VR31-1 and VR31-2 (semi-fixed resistor 200 $\Omega$ -B) are wound counterclockwise.
- Set the Power Switch to the "ON" position. Adjust VR31-1 and VR31-2 so that the AM meter needle indicates "0".
- The foregoing should accomplish adjustment. In this condition Collector Voltage of 2SD130 (Power Output Transistor) should read 26 to 27 V, with Collector Current at 70 to 100 mA.

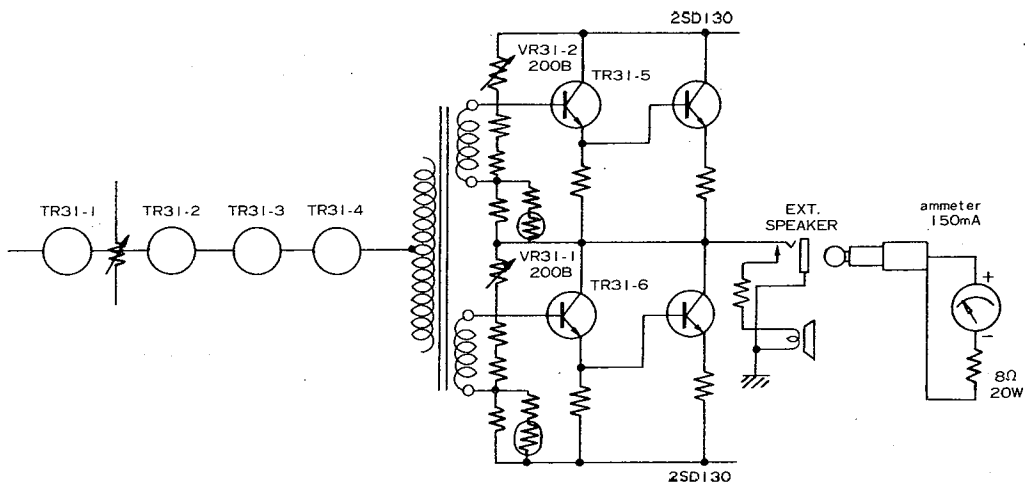

Fig. 1

#### 4. RECORDING AMPLIFIER ADJUSTMENT

Recording Amplifier Adjustment should be made only after Head Adjustment (vertical and horizontal azimuth) and Playback Amplifier Adjustments have been performed.

- Load a blank test tape (Scotch No. 150) on the Tape Recorder.
- As shown in Fig. 2, connect an Audio Oscillator and Attenuator to the Line Input. Connect a High-sensitivity V.T.V.M. to the Line Output.
- Set the Tape Speed Selector to "7-1/2" and the Monitor Switch to "TAPE" position.
- By using the Audio Oscillator, supply a 1,000 Hz signal. Set the tape to transport, and the Record Interlock Button to recording mode.
- Adjust the Line Level Control so that the VU meter needle indicates "0" (white dot).
- Set the Monitor Switch to "SOURCE" position. Adjust the VR28-1 (semi-fixed resistor, 20 K-B) of Recording Amplifier Board (RD-528) so that the VU meter needle indicates "0" (white dot).

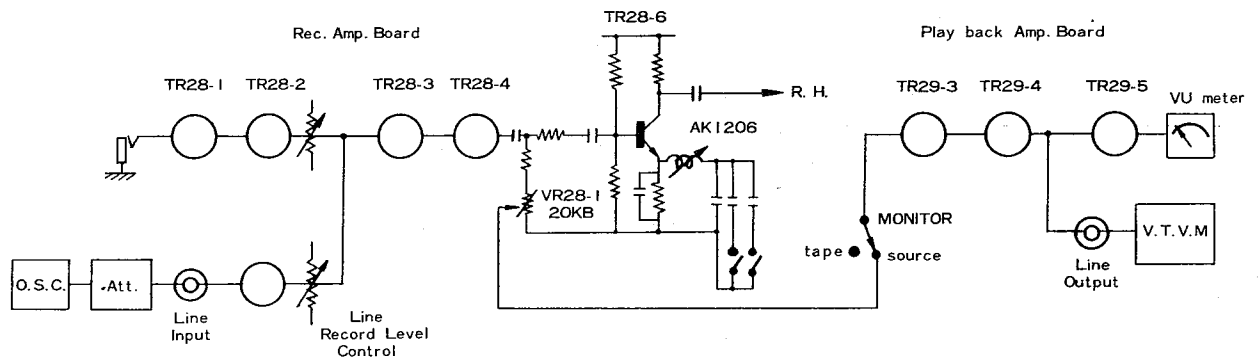

Fig. 2

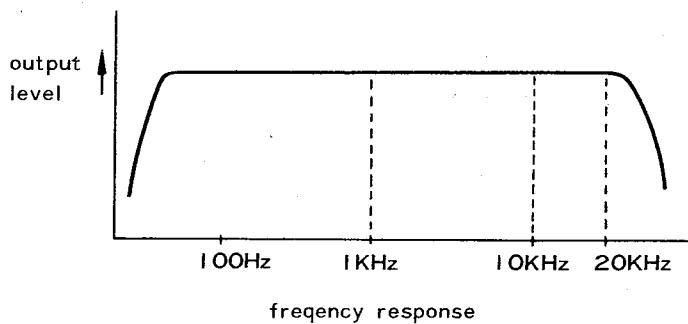

Fig. 3

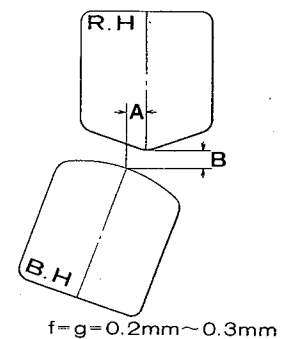

Fig. 4

## 5. RECORDING EQUALIZATION CHARACTERISTICS ADJUSTMENT

- For tape and meters, follow the procedure used for the adjustment of the recording amplifier.
- Adjust the Recording Level Control by setting the Monitor Switch to "SOURCE" position so that the VU meter needle indicates "0" (white dot).
- Attenuate the Audio Oscillator signal by 20 db.
- Start the tape, by pushing the Forward Button then press the Record Button to record. The Monitor Switch must be set to "TAPE" position.
- As shown in Fig. 3, increase the frequency of the Audio Frequency Oscillator by steps from 1 KHz to 10 KHz. Adjust Bias Voltage and Bias Head angle including the gap between Bias and Recording heads. The V.T.V.M. which is connected to the Line Output, should indicate the same voltage when using 1 KHz to 10 KHz.
- During 7-1/2" operation, the Bias Voltage may be adjusted by turning the white knob VR30-1 (semi-fixed resistor 2K-B) of Bias Oscillator Board (RD-530) clockwise.

This adjustment should begin when VR30-1 is fully wound in the clockwise position.

- As shown in Fig. 4, Gaps A and B, which are between the Recording and Bias Heads, should be about 0.2 mm.
- After completion of the foregoing, observe the Recording Playback Output Voltage at 1 KHz and 10 KHz. If this voltage remains constant, change the frequency response of Audio Oscillator continuously. Check to see that the Output Voltages are within  $\pm 3$  dB at any condition up to 20 KHz. If the response around 20 KHz reads more than  $\pm 3$  dB difference when compared with response at 10 KHz, adjust the Peaking Coil (AKI206) of the Recording Amplifier to match the High-range response.
- If the frequency response is gained as specified, reset the Attenuator Dial to read "0" VU. Follow the operation as detailed in 4 (e) & (f), and re-adjust the Recording Level of the Recording Amplifier to 0 VU at 1,000 Hz.

- Set the Tape Speed Selector to "3-3/4" and attenuate the Input signal to  $-20$  dB. Adjust the VR30-2 (semi-fixed resistor 5 K-B) of Bias Oscillator Board (RD-530) so that the responses at 1 KHz and 10 KHz in Recording/Playback condition, are at the same level.
- After the same response at 1 KHz and 10 KHz has been gained, increase the Input signal to 18 KHz by steps. Check whether 18 KHz is within  $-6$ dB.
- Distortion level at 7-1/2" should be within 2% and 3% at "3-3/4".

## 6. DM DETECTOR SENSITIVITY ADJUSTMENT

- Before adjustment, remove the solder at point P (Time Delay circuit of 15 seconds) which is shown in Figs. 5 and 6.
- Turn the Microphone Record Level Control (left channel) slightly clockwise from the medium level position. Then, record the non-input signal for 15 seconds.
- Playback that signal. Adjust VR71-1 (semi-fixed resistor 10 K-B) of DM Detector Card so that DM indicator lamp is extinguished.
- Playback a new blank tape. Adjust VR71-1 so that the Indicator lamp lights.
- Check to see that the lamp is lighted when the tape is off the Playback Head during playback operation.
- Solder Point P as shown in Figs. 5 and 6. After soldering, the DM Indicator Lamp should light after 15 seconds following the stoppage of input signal to the DM Detector circuit.

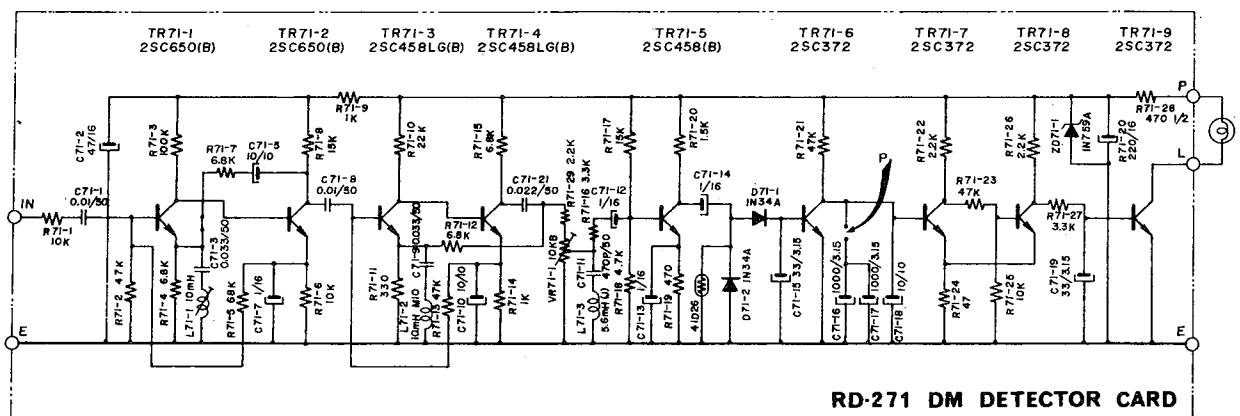

Fig. 5

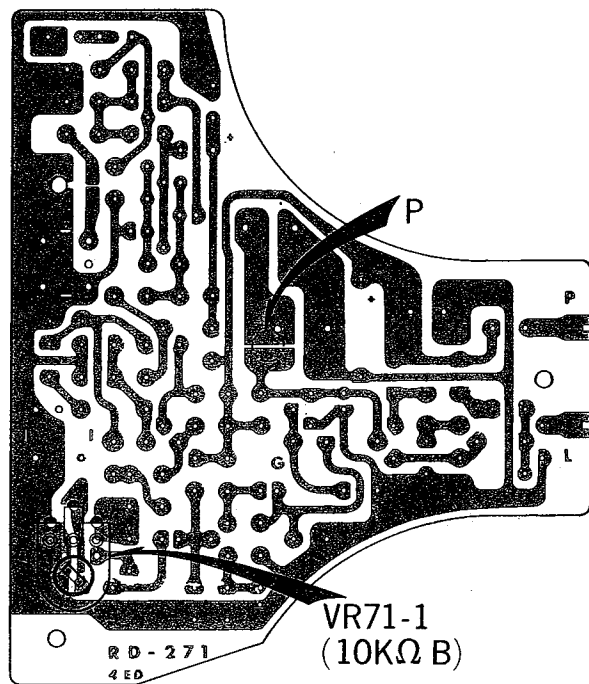

Fig. 6

## 7. ADJUSTMENT OF COMPUT-O-MATIC RECORDING LEVEL SENSITIVITY

- a) As shown in Fig. 7, connect an Audio Oscillator to the Left Line Input Jack (56) of the tape recorder, and supply a 1,000 Hz signal.
- b) Push the "SOURCE" Monitor Button. Set the Track Selector to "STEREO".
- c) Turn the Line Record Level Control Knob (19) so that the left channel VU meter needle indicates "O" VU (white mark). The COMPUT-O-MATIC should be set to the "OFF" position.
- d) Push the COMPUT-O-MATIC Button to the "ON" position, and the Indicator needle automatically moves from maximum to "O" VU level.
- e) Adjust the semi fixed resistor VR70-1 (100KB) of COM DETECTOR CARD (RD-570) so that VU meter needle indicates exactly "O" VU.
- f) If the VU meter needle indicates lower than "O" VU, reset the COMPUT-O-MATIC Button to "OFF" position. Readjust the VR70-1 to an increased value, push the button to "ON" and recheck.

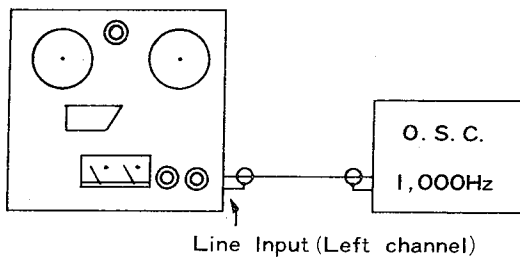

Fig. 7

## VII. MECHANISM ADJUSTMENT

### 6. Mechanism Adjustment

#### 6.1 Alignment of Capstan Drive Mechanism

The Capstan Drive Belt should run in the center of the Motor Pulley and Flywheel, as shown in Figure 1. To position the Capstan Drive Belt, with proper clearance between the Motor Mounting Plate and the Chassis use adjusting Screws (C) and (A), shown in Figure 2. After adjustment, tighten Lock Screws (B) and (D).

- 1) With Motor rotating in the Normal direction, loosen Screws (B) and (D) and adjust Belt position by turning Screw (C).
- 2) With Motor rotating in the Reverse direction, adjust Belt position by turning Screw (A). After Drive Belt position has been properly adjusted to run in the center of the Motor Pulley and Flywheel (according to direction of motor rotation), lock by tightening Screws (B) and (D).

- 3) With the Motor rotating and with the recorder switched from 50 to 60 Hz, verify that the Drive Belt does not contact the Belt Shift Lever.
- 4) If the Drive Belt contacts the Belt Shift Lever, loosen Screw (E), and move the Belt Shift Lever Stopper so that the Belt does not contact the Shift Lever.

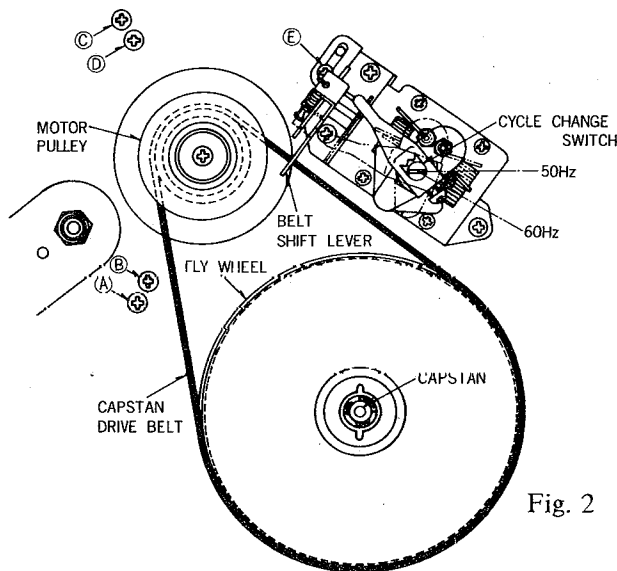

Fig. 2

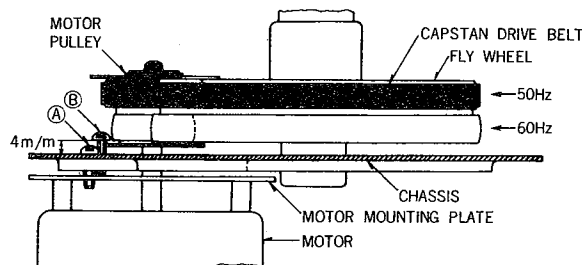

Fig. 1

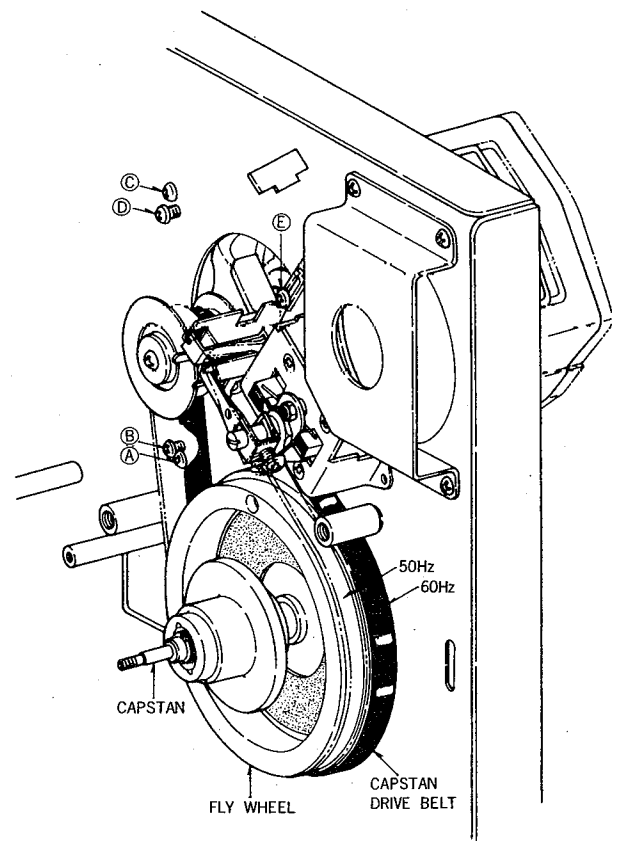
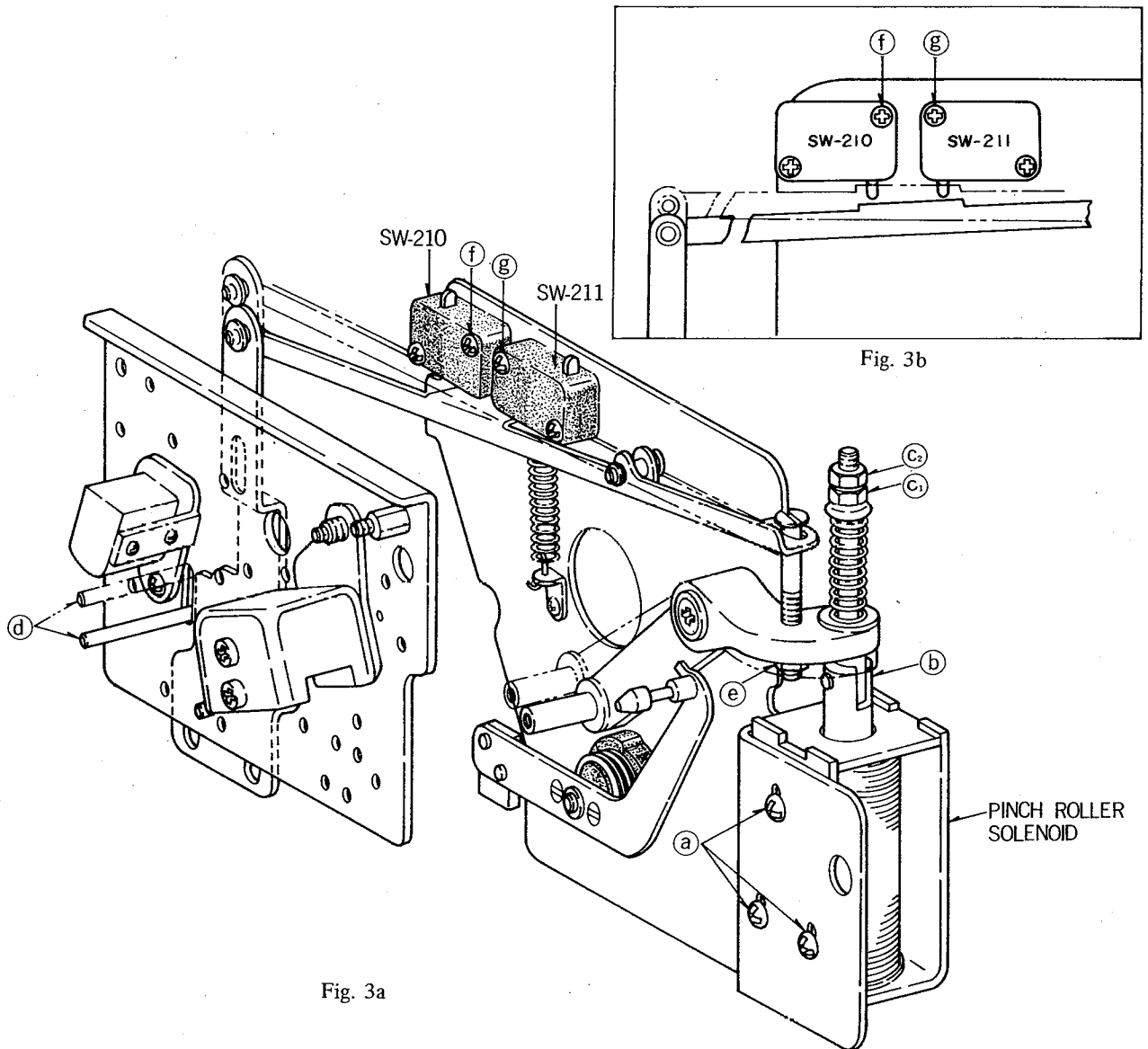

Fig. 1,2

2. Adjustment of Pinch Roller Mechanism

- 1) Pinch Roller Solenoid Position—Set the Solenoid so that there is approximately 0.3 mm clearance between the end of Plunger (b) and the bottom of the Solenoid when the Pinch Roller Shaft is depressed with your finger, and then tighten Screw (a). (See Figure 3a)
- 2) Pinch Roller Pressure—Apply a Tension Gauge to the Pinch Roller Shaft, and adjust Nut (C1) so that pressure is 1.8 kg/cm when set for Playback. Then tighten Nut (C2) and secure with Nut (C1).

- 3) Adjust Nut (e) so that there is approximately 0.5 mm clearance between Shifter Pin (d) and the upper edge of the hole in the Head Mounting Plate when set for Playback.
- 4) Set to Playback with the Pinch Roller contacting the Capstan and verify that the Tape Shifter Lever depresses Microswitch SW-210 and SW-211 Pins, as shown in Figure 3b, and make sure that switches operate correctly. To adjust positions of Microswitches SW-210 and SW-211, loosen Screws (f) and (g).



### 3. Adjustment Brake Mechanism

- 1) To adjust Brake Solenoid position, align the Left and Right Brake Levers when the Solenoid Plunger is retracted.
- 2) One end of the Brake Band is centered in the elliptical hole in the Brake Band, as shown by (a) (a') in Figure 4a.
- 3) For metal Brake Band Retainer, adjust Screw (b), so that the clearance between the Brake Band and motor circumference is uniform, as shown in Figure 4B.
- 4) Adjust the set position of the Brake Band Spring so that Brake tension is 150 grams (using 60 mm diameter tape and measuring with a Tension Gauge) (See Figure 4a (c) (c')).

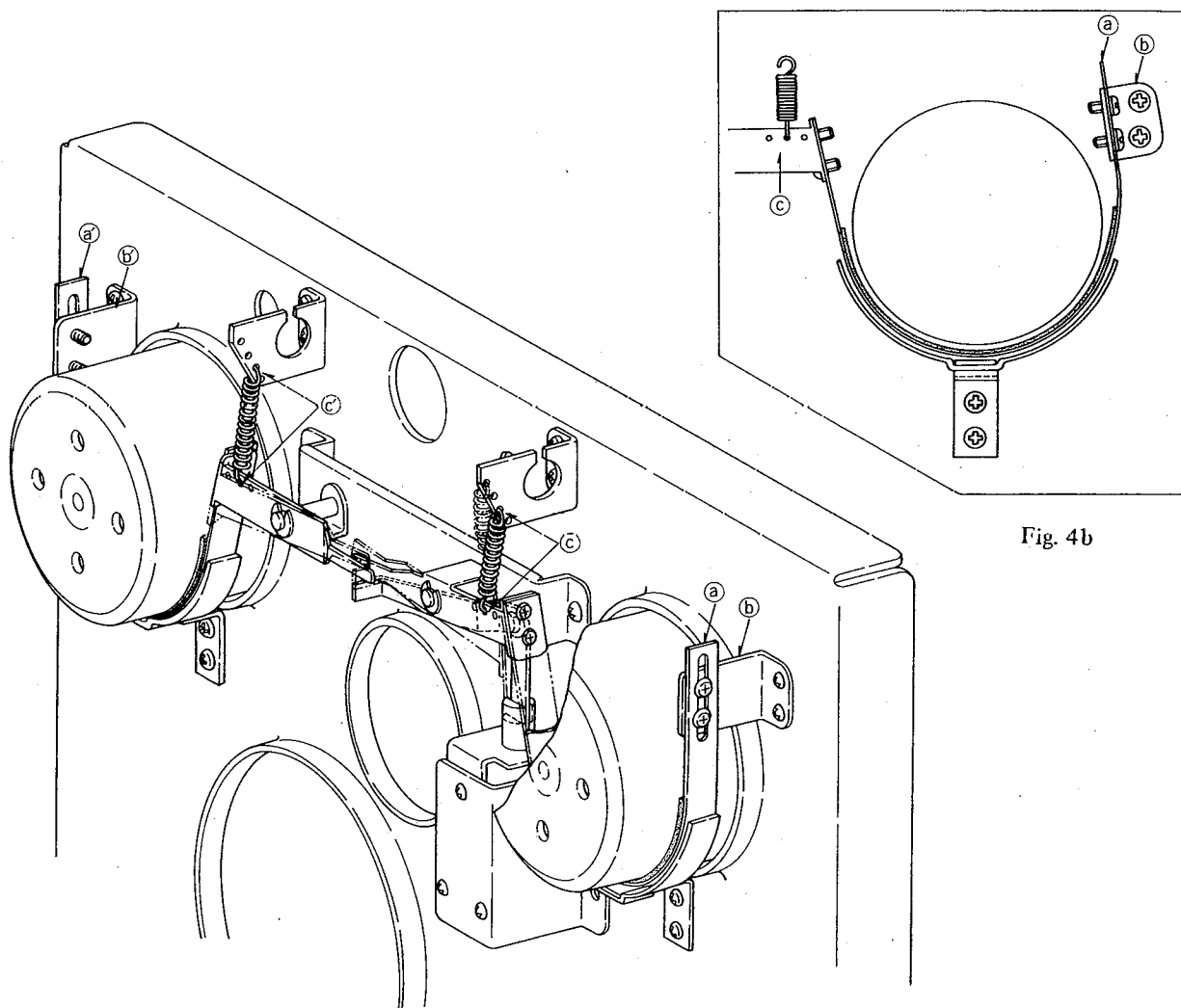

Fig. 4a

Fig. 4b



#### 4. Adjustment of Tape

For all measurements, use 60 mm diameter tape, and measure tape tension with a Tension Gauge.

Set the Magnetic Brake Control Switch to STANDARD.

- 1) Back tension for "Reverse Play" depends upon the torque of Motor B, as shown in Figure 6. Adjust back tension to 60 grams adjusting the 230  $\Omega$  Resistor (F), as shown in Figure 5. At this tension setting, voltage applied to Motor B is approximately 29 V.
- 2) Take-Up tension for "Normal Play" depends upon the torque of Motor B, as shown in Figure 6. Adjust take-up tension to 100 grams by adjusting the 120  $\Omega$  Resistor (A), as shown in Figure 5. At this tension setting, voltage applied to Motor B is approximately 41 V.

- 3) Back tension for "Normal Play" depends upon the torque of Motor A, as shown in Figure 6. Adjust back tension to 60 grams by adjusting the 230  $\Omega$  Resistor (F), as shown in Figure 5. At this tension setting, voltage applied to Motor A is approximately 29V.
- 4) Take-up tension for "Reverse Play" depends upon the torque of Motor A, as shown in Figure 6. Adjust Take-up tension to 220 grams by adjusting the 120  $\Omega$  Resistor (A), as shown in Figure 5. At this tension setting, voltage applied to Motor A is approximately 62V.

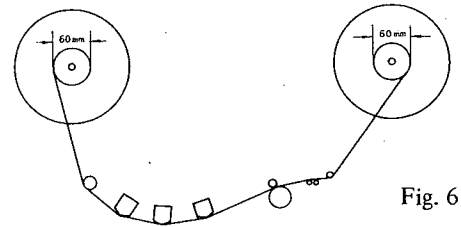

Fig. 6

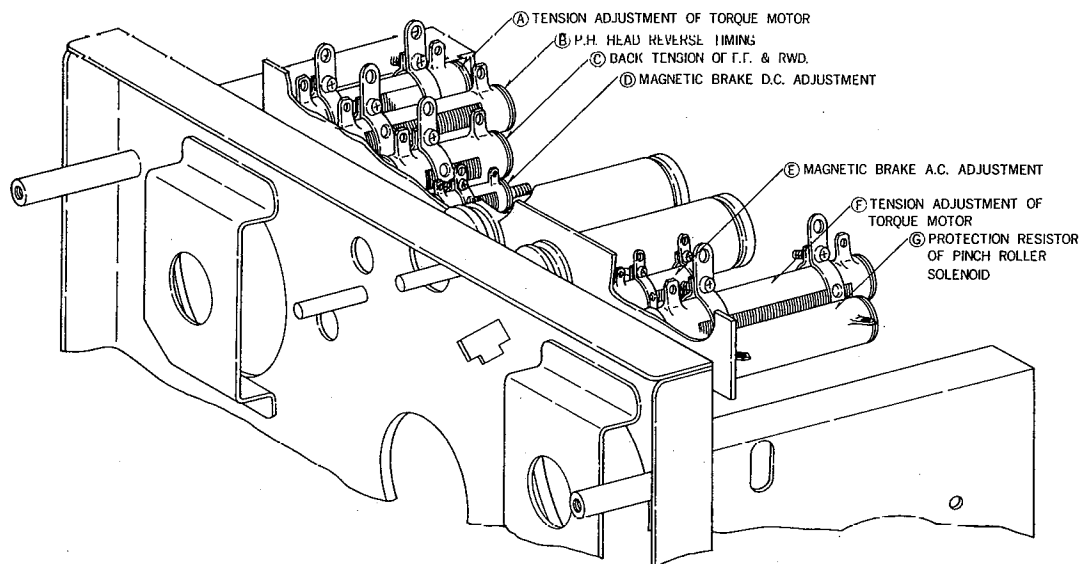
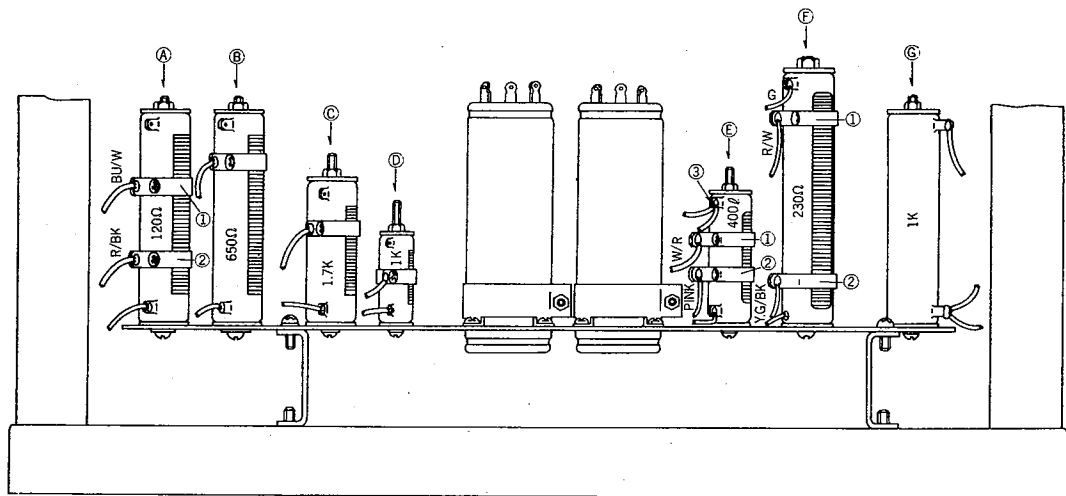

Fig. 5

- 
5. Adjustment of Playback Head Reverse Timing  
The Playback Head reproduces on Tracks 1-3 for "Normal Play" and on Tracks 2-4 for "Reverse Play" when using Stereo Tape.  
The Playback Head lowers to Track 2-4 position, when switched from Normal to Reverse Play. If the Playback Head lowers with the tape contacting the Head, a loud noise will be heard from the speaker. The Tape Shifter releases the tape from contact with the Playback Head before the Head lowers.  
Adjust the 650  $\Omega$  Resistor (B), as shown in Figure 5, so that 38 Volts is applied between the terminals (white and gray wire) (Reverse Head Solenoid Coil).
6. Adjustment of Magnetic Brake
- 1) Adjust the 400  $\Omega$  Resistor (E) (in Figure 5) so that the terminals on each end of the Resistor are equidistant.
  - 2) Center the Slider of the 1K  $\Omega$  Resistor (D), as shown in Figure 5. (D.C. Brake)
  - 3) Set the Magnetic Brake Control Switch to STANDARD. Depress the STOP Button near the outer end of a 7" reel of tape at FAST FORWARD to determine whether the tape turns in the rewind direction.
  - 4) If the tape turns in the rewind direction, increase D.C. Brake voltage by adjusting the Slider (1) of the 1K  $\Omega$  Resistor (D) to decrease resistance or adjust slider (1) toward terminal (3) of the 400  $\Omega$  Resistor (E), as shown in Figure 5. Also verify that Brake Band tension is accurately adjusted to 150 grams.
  - 5) Set the Magnetic Brake Control Switch to 1.0 or 0.5 mil and check the following: FAST FORWARD  $\rightarrow$  STOP, REWIND  $\rightarrow$  STOP. If the tape loses its tension and becomes slack at STOP, move the Slider (2) of 400  $\Omega$  Resistor (E) toward Slider (1), as shown in Figure 5.  
After the foregoing adjustments, verify (with the Magnetic Brake operating) that torque motor tension is as follows:  
Standard : approx. 300 ~ 330 gram.  
1.0 or 1/2 mil : approx. 250 gram.
7. Adjustment of Back Tension for FAST FORWARD and REWIND.
- 1) Adjust the slider of the 1.7 K $\Omega$  Resistor (C), shown in Figure 5, so that overall resistance is 1.3 K $\Omega$ . If Resistor (C) itself is 1.3 K $\Omega$ , no adjustment is required.
8. Adjustment of Reel Table Height  
To adjust Reel height, loosen the two screws on the bottom of the Reel Table and adjust so that height from the Chassis to the upper edge of the Reel Table is 53.5 mm.
-

## VIII. TRANSPORT MECHANISM

---

Explanation of Relays and Solenoids included in X-360.

REC 2	:	Recording Relay 2 Actuated by REC Relay 1. Switches Recording Head to ON/OFF.
RT	:	Reverse Timing Relay Charges at 220 $\mu$ when changing from Reverse to Normal operation.
REV H	:	Head Reverse Solenoid Depresses Playback Head to Reverse position in the reverse mode.
REV 1	:	Reverse Relay 1 Reverses motor rotation. Locks Reverse circuit. Controls PLY Relay.
REV 2	:	Reverse Relay 2 Switches the Reel Motor Tension during Reverse operation.
REV 3	:	Reverse Relay 3 Switches the Playback Head connection (L.ch. R.ch.) during Reverse operation.
PT	:	Pinch Roller Timing Stops tape in 4 seconds while changing Normal and Reverse.
PLY	:	Play Relay Locks BRK., QT., PR. control & PLY circuit.
PR	:	Pinch Roller Solenoid
REC 1	:	Recording Relay 1 Locks REC Relay 2 control and Recording circuit.
BIAS	:	Bias Head Control Solenoid
QT	:	Quick Tension Used under all operations and at starting time, operates to provide Reel. Motor a high force.
BRK	:	Brake Solenoid
MAG	:	Magnetic Brake Relay Constantly ON during normal operation. In Off position Magnetic Brake circuit operates.
TIM	:	Time Constant Relay ON during Fast Forward and Rewind operations. Controls Magnetic Brake operation.
RWD	:	Rewind Relay
FF	:	Fast Forward
DS	:	Direction Switch Relay Operates only during Rewind mode. Controls the direction of the Magnetic Brake operation.
SENS	:	Sensing Relay Operated by Sensing Tape or Reverse Dial. Also sets Reverse circuit to ON.

# SYSTEM CONTROL BOARD (RD-144) BLOCK DIAGRAM

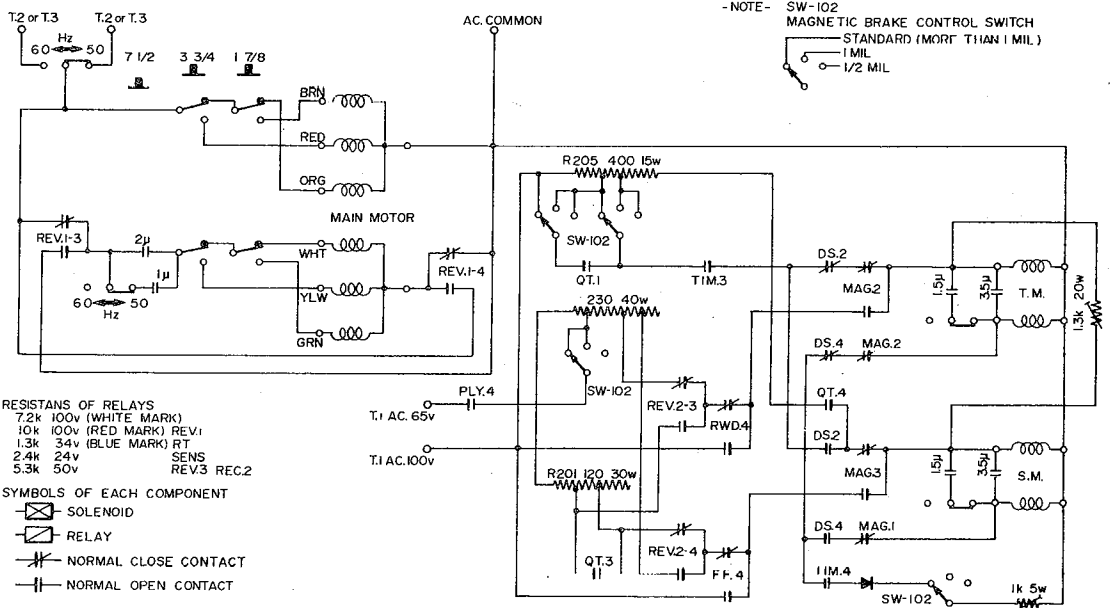
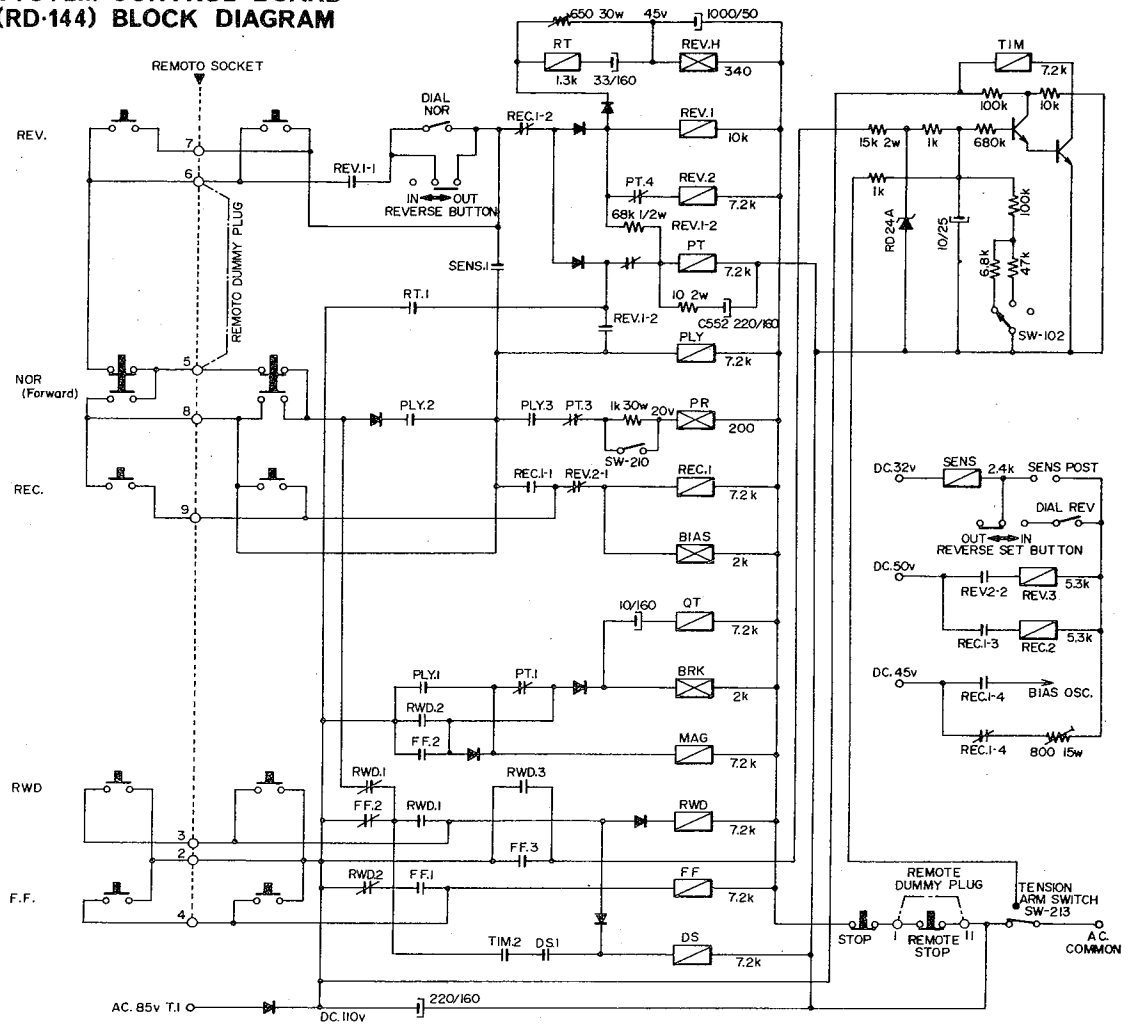

1. Relays & Solenoids Actuated for Each Operation

Function	R.T.	REV1	REV2	REV3	P.T.	PLY	REC1	REC2	SENS	Q.T	MAG.	RWD.	F.F.	DS	TIM.	Solenoid				
																REV.H	PR	BIAS	BRK	
Normal Play						○				○	○							○		○
Reverse Play	○	○	○	○	○	○			○	○	○						○	○		○
Recording						○	○	○		○	○							○	○	○
Fast Forward										○	○		○		○					○
Rewind										○	○	○		○	○					○

○ mark indicates "engaged".

Fig. 1

2. STOP

Load a tape and depress the Power Switch. Current flows as indicated by the red line in Figure 2, driving the Main Motor in the normal direction, and lights the VU Meter Lamp.

3. PLAY

With the Recorder set to STOP, depress the FORWARD Button. Current flows as indicated in Figure 3, actuating the PLY, QT, and MAG Relays and the P.R. and BRK Solenoids. Tape is fed in the normal (forward) direction at a constant speed as current is supplied through R201 and R206 to Left and Right Reel Motors. To provide increased starting torque for the Reel Motors, the QT Relay is actuated approximately 0.2 second after the FORWARD Button is depressed, partially shorting R201 and applying higher voltage to the Take-up Motor. The Block Diagram clearly show the operation of the individual relays.

4. FAST FORWARD

When the FAST FORWARD Button is depressed, current flows as indicated in Figure 4, actuating the FF, MAG, QT, and TIM Relays and the BRK Solenoid. 100V is supplied to the Take-up Motor, and 13V is fed to the Supply Motor through R203, for back tension application during FAST FORWARD feed.

5. REWIND

When the REWIND Button is depressed, current flows as indicated in Figure 5, actuating the RWD, QT, MAG, DS, and TIM Relays and the BRK Solenoid. 100V is supplied to the Supply Motor and 13V is fed to the Take-up Motor through R203, for back tension application during REWIND.

6. Magnetic Brake

When the STOP Button is depressed during FAST FORWARD or REWIND, the Magnetic Brake smoothly and quickly stops the fast moving tape.

a) When the STOP Button is depressed during REWIND, Condenser C44-7 (10  $\mu$ F) is discharged through VR44-1 (100K  $\Omega$ ) and R44-4 (6.8K  $\Omega$ ), as shown in Figure 6.

Discharge Time Constant is 2 seconds with SW102 set to STANDARD, or 4 seconds when set to 1 or 1/2 mil. During discharge Tr44-1 (2SC372) and Tr44-2(2SC728), as well as TIM and DS Relays remain engaged. 65V AC is supplied to the Take-up Motor through R205 (400  $\Omega$ ) and DC current is supplied to the Take-up Motor Sub Coil through R205(1K  $\Omega$ ) and Diode (10D4), allowing the Take-up Motor to serve as a Brake.

b) When the STOP Button is depressed during FAST FORWARD, the TIM Relay remains engaged, and supplies both AC and DC to the Supply Motor which serves as a Brake for the fast moving tape. When the Magnetic Brake Control Switch SW-102 is set to 1 or 1/2 mil, D44-11 and R204 are cut out from the circuit and AC only is supplied to the Motor.

Because the Brake Band only assists the Magnetic Brake, Brake Tension (Braking Power) applied by the Brake Band can be of a comparatively smaller value than usual.

STOP

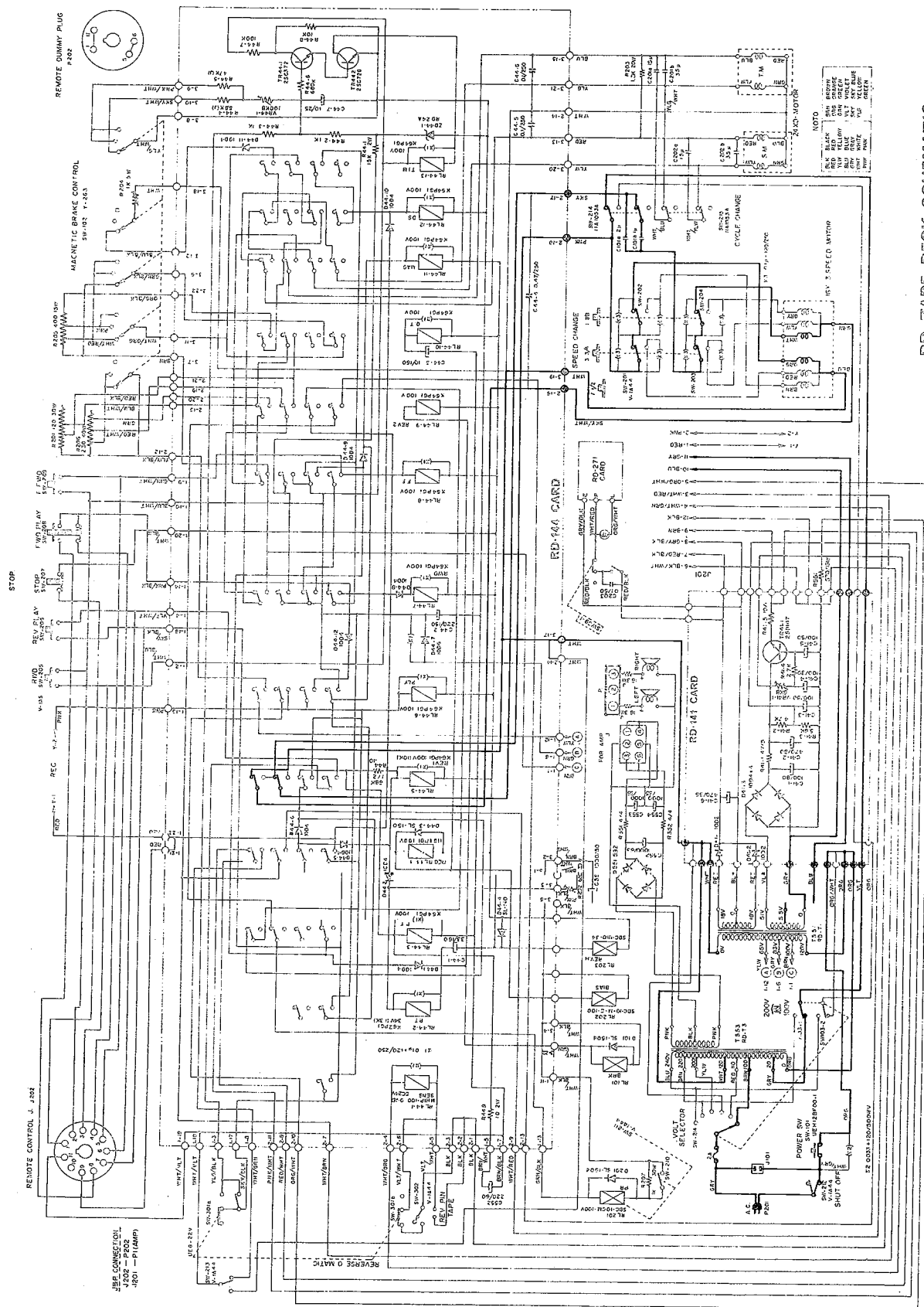

RD TAPE DECK SCHEMATIC

Fig. 2

NORMAL PLAY

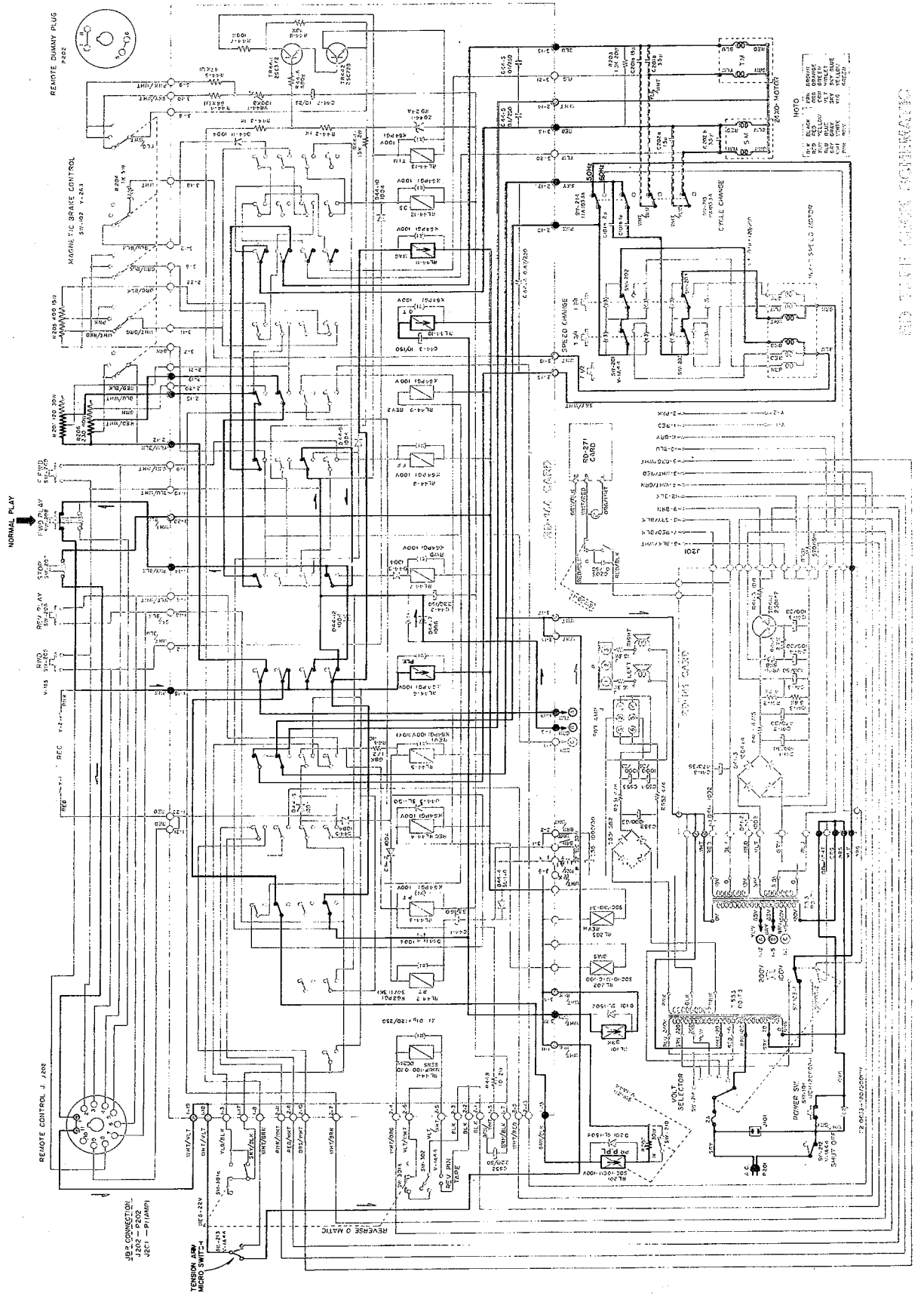
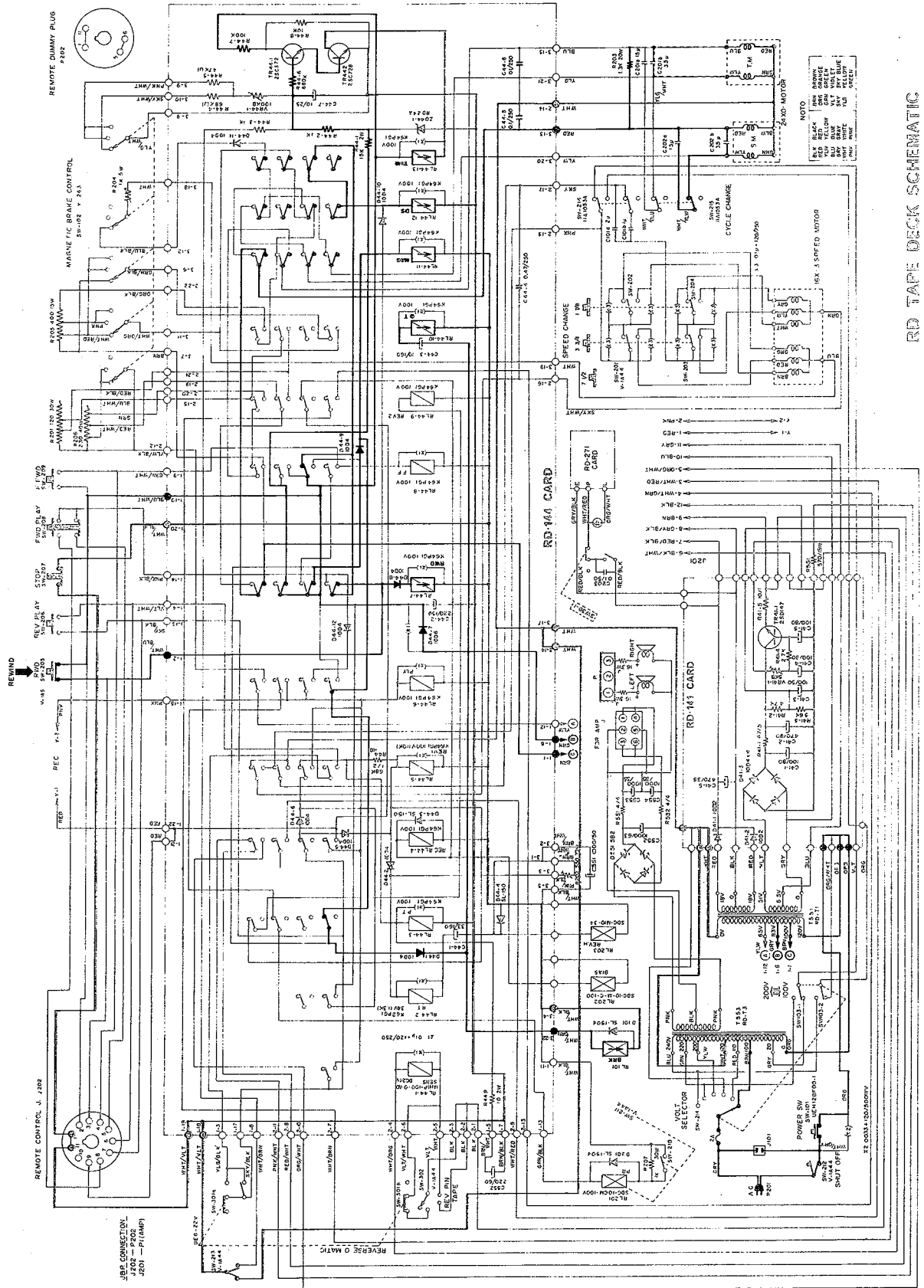

Fig. 3





REWIND



RD TAPE DECK SCHEMATIC

Fig 5



## 7. REVERSE PLAY

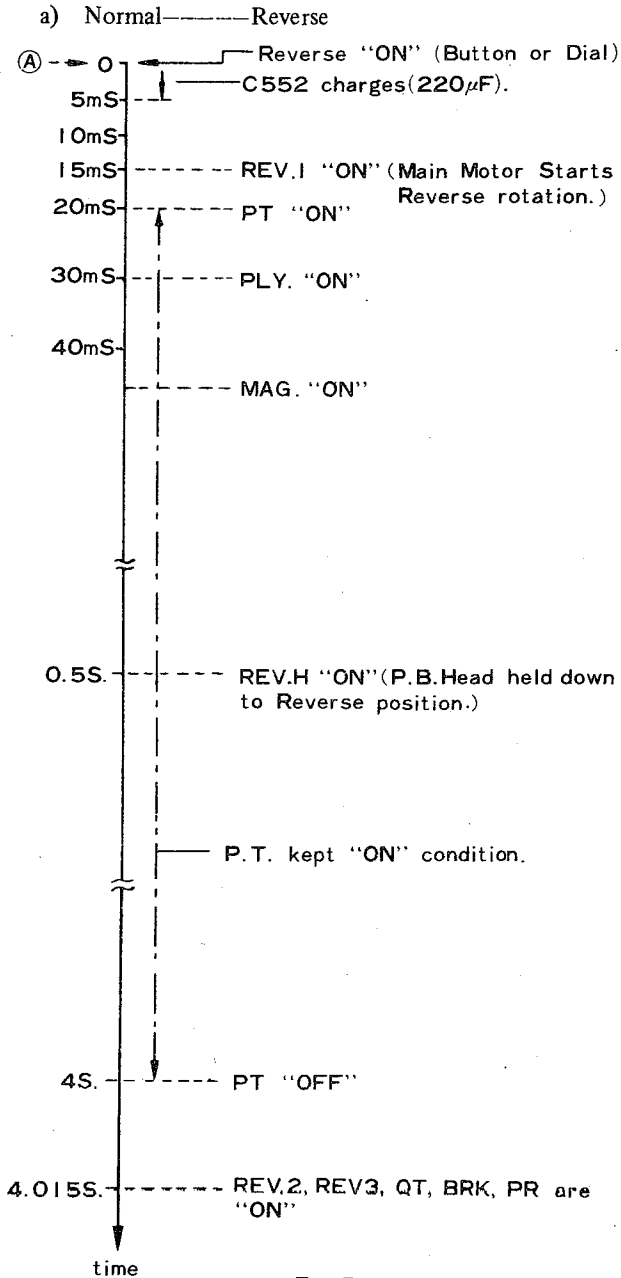
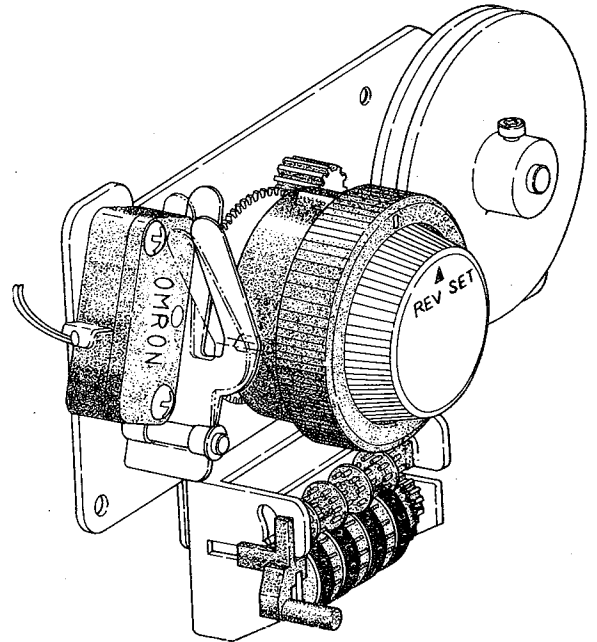

Fig. 7

Sequence of operation when the REVERSE Button is depressed, or when the White Mark on the Tape Count Meter reaches the Black Arrow of the Reverse Set Dial as follows for Automatic Reverse. Assuming this is point (A), Figure 7 shows Relay and Solenoid operating sequence beginning at this point.

Relay operation can be clearly understood by referring to the System Control Board Block Diagram (Figure 8.). As soon as REVERSE is actuated ("ON") at point (A), current begins to flow in the Reverse Circuit. Since it takes about 15 milliseconds before the contact is operative, C552 (220  $\mu$ F) is charged within approximately 5 milliseconds through REV1-2 (normally closed contact).

15 milliseconds later, REV1 Relay is actuated ("ON") and the normally closed contact of REV1-2, is opened, 220  $\mu$ F is discharged through the 10  $\Omega$  Resistor and the PT Relay. The PT Relay remains engaged and the pinch roller disengages during the 4-second Discharge Time. The REV1 Relay is actuated ("ON") during this 4 seconds, starting the Main Motor rotating in the reverse direction. PLY and MAG Relays are actuated ("ON"), permitting current to flow to the Left and Right Reel Motors. The REV. H Solenoid is actuated ("ON"), the Playback Head lowers to its REVERSE position. The PT Relay is now cut off, and the pinch roller engages. Approximately 15 milliseconds later the REV2, REV3, and QT Relays and the BRK and PR Solenoids are actuated ("ON"), causing the tape travel to REVERSE.





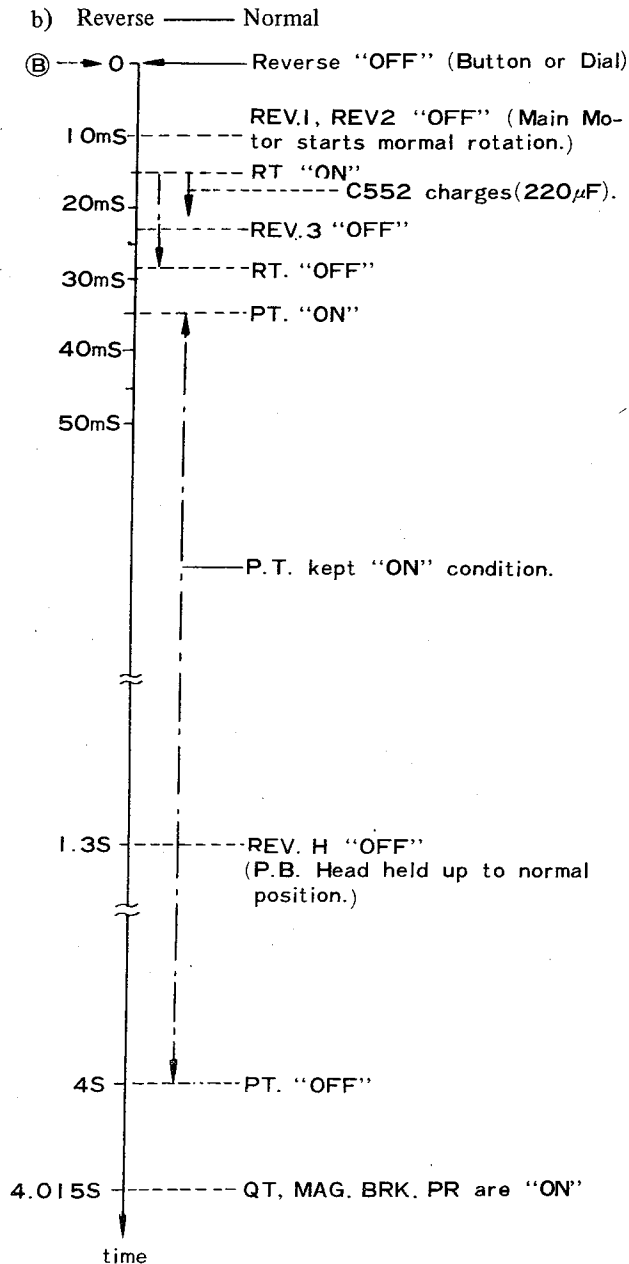

Fig. 9

Sequence of operation when the FORWARD Button is depressed during REVERSE PLAY, or when the White Mark on the Tape Count Meter reaches the "O" Mark on the Tape Count Scale used for Automatic Reverse is as follows, assuming this is point "B".

Reverse Circuit current is cut off at point(B), but REV1 and REV2 remain engaged for approximately 10 milliseconds. As REV1 is disengaged, the Main Motor starts rotating in the Normal direction. When the current in the Reverse Circuit is cut off, the 33 µF Condenser, which is series connects to the RT Relay and charged during Reverse Play, is discharged through the RT Relay Coil and the 650 Ω Resistor. The Discharge Time is about 28 milliseconds. Thus, the RT Relay remains engaged approximately 13 milliseconds. (See Figure 9)

RT1 normally open contact is closed and Condenser C552 (220 µF) is charged in approximately 5 milliseconds.

As RT1 closes, current starts flowing to the PT Relay Coil. As RT1 opens, C552 discharges and the PT Relay is engaged 35 milliseconds later, and continues to be operative for about 4 seconds, after which it is engaged. C551 (1000 µF) discharges current to the REV.H Solenoid Coil. in approximately 1.3 seconds after point (B), the REV.H is disengaged and the Playback Head raises to its Normal Play position.

As the PT Relay is disengaged, current flows to QT and MAG Relays and to BRK and PR Solenoids through the normally closed contacts. After approximately 15 milliseconds, the QT and MAG Relays and the BRK and PR Solenoids are actuated ("ON"), and tape travel starts in the Normal direction.

#### 8. Comput-O-matic

a) By depressing the Set Button (SW25-1) with no input signal applied to Line Input or Microphone Jacks, current flows to the Comput-O-Matic Motor through the Relay (MH2PM-0) (a normally closed contact) and the Microswitch (SW92-1), causing the Motor to rotate in the direction indicated by the blue line in Figure 10.

The Motor Shaft is connected to the Comput-O-Matic Volume Control Shaft by gear mechanism. When the Motor rotates in the direction indicated by the blue line, the Volume Control turns toward the upper limit (maximum). When the Volume Control reaches the upper limit, Microswitch SW92-1 is cut off by the cam attached to the Volume Control Shaft, cutting the flow of current to the Motor, thus, stopping the Motor.

As current is cut off, Bias Voltage is applied to Transistor TR70-8, through R70-23 and R70-22, actuating TR70-8. As TR70-8 is actuated ("ON") collector current flows through the Relay Coil MH2PM-0, engaging the Relay. However, when no input signal is applied, current does not flow to the Motor because Transistor TR70-7 is inoperative (OFF), as shown in Figure 10.

b) Under conditions as described above, but when input signals are applied to the Line Input or Microphone Input Jacks (for input signals level of 0 VU or greater) the function of Transistors are as shown by the red print in Figure 10. As TR70-7 is actuated, TR70-7 collector current flows through the Motor, causing the Motor to rotate in the direction indicated by the red arrow in Figure 10.

As the Motor rotates in the direction indicated by the red arrow, the Volume Control rotates from the upper limit toward the lower limit (minimum). The input signals applied to the

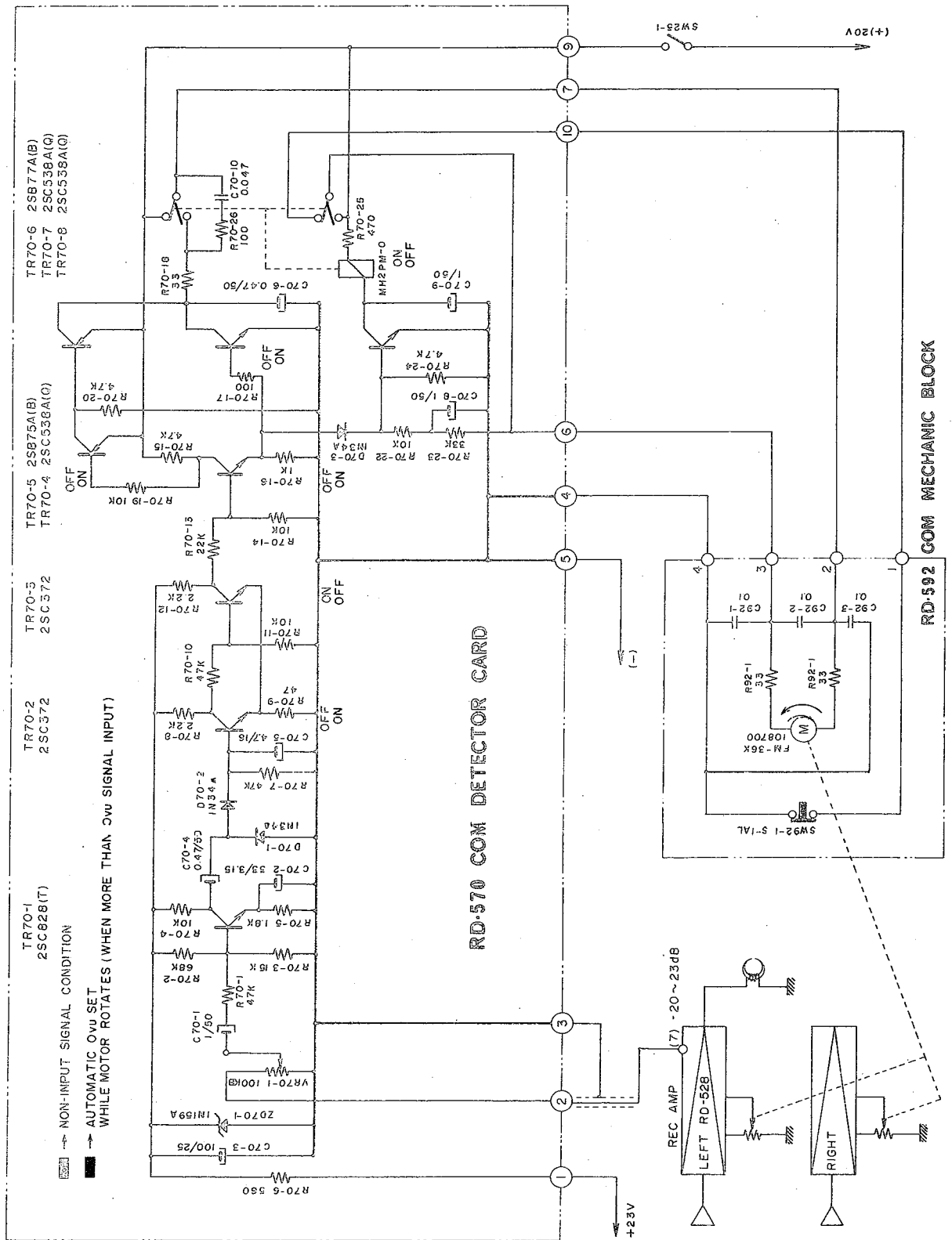

Fig 10

Recording Amplifier are decreased by the Volume Control, and the COM Detector Card input signal level is reduced accordingly.

When the signal level to the Recording Amplifier is reduced to 0 VU, the conditions of the COM Detector Card Transistors are again as indicated in blue print in Figure 10, TR70-7 is cut off and the Motor stops.

TR70-5 and TR70-6 insure that the Motor stops immediately when signal level reaches 0 VU.

- c) Since the Comput-O-Matic Motor operates only in the direction for decreasing the signal level (with input signals applied), if the input signal becomes too low, Comput-O-Matic recording level must be reset by depressing the Set Button "OFF" and then back "ON". At this time, Relay MH2PM-0 is cut off (as described in (a) above). Thus, the Volume Control rotates toward the upper limit, automatically stopping when the VU Meter Indicator Needle registers 0 VU.

9. DM Detector

The DM Detector Circuit automatically detects the quality of recorded sound, and when Playback level deteriorates during recording and playback (due to dirt, magnetic oxide, etc. on the Recording or

Playback Heads), the D.M. Indicator Lamp lights. 9 KHz is used as a drive signal for the DM Detector Circuit. The DM Detector Card is connected to the 1st Stage of the Playback Amplifier, as shown in Figure 11.

The 1st through the 5th Stages of the DM Detector Circuit serve as a 9 KHz Filter Amplifier. A 90 KHz Bias Trap Circuit is inserted between the 4th and 5th Stages to prevent operational error from Magnetic Bias Flux during recording.

The circuitry from the 6th through the 9th Stages serve as switching circuits. Presence of the 9 KHz component in Playback output signals results in the condition printed in blue in Figure 11, Transistor TR71-9 stops functioning and the DM Indicator Lamp is extinguished. If the Playback Head is dirty and no 9 KHz component is included in the playback output signals, conditions will be as indicated in red print in Figure 11, TR1-9 will be actuated ("ON") and the Indicator Lamp will light. Also, if the Recording Head is dirty during recording and no 9 KHz component is included in the playback output signals, the Lamp will light.

At 1-7/8 ips tape speed, power is cut to the DM Detector by the Speed Selector Switch SW39-1, thus DM Detector circuit won't function. During STOP, as there is no need for the Lamp, so power is cut to the DM Detector Circuit by Microswitch SW207.

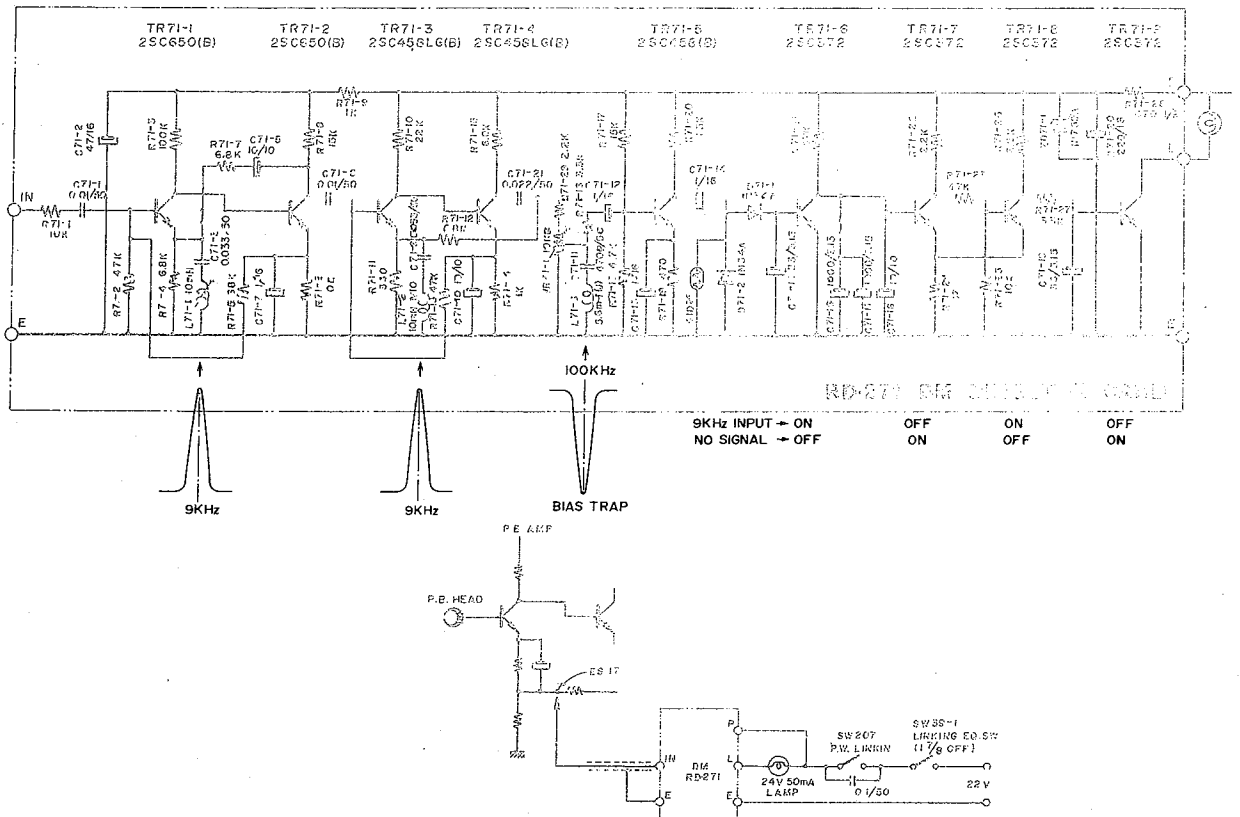

Fig. 11

# IX. MAINTENANCE PROCEDURES

## 1. LUBRICATION INSTRUCTION

For maximum service life and optimum performance, lubricate the parts identified below after each 1,000 ~ 1,500 hours of operation. Use only light machine oil of good quality.

Main Motor  
Capstan Shaft  
Pinch Wheel Shaft  
Tape Counter

Also apply a liberal film of light machine grease to each roller surface of all levers and cams.

**CAUTION: DO NOT OVER-LUBRICATE, AND WIPE OFF EXCESS OIL WITH A COTTON SWAB SOAKED IN ALCOHOL. OTHERWISE, EXCESS LUBRICANT MAY BE SCATTERED DURING OPERATION. AND THE RUBBER COMPONENT PARTS WILL DETERIORATE.**

## 2. CLEANING TAPE HEADS AND OTHER

Wipe surface of tape heads, guide roller bearing, capstan bushing and pinch wheel periodically with a soft cloth soaked in alcohol or carbon-tet.

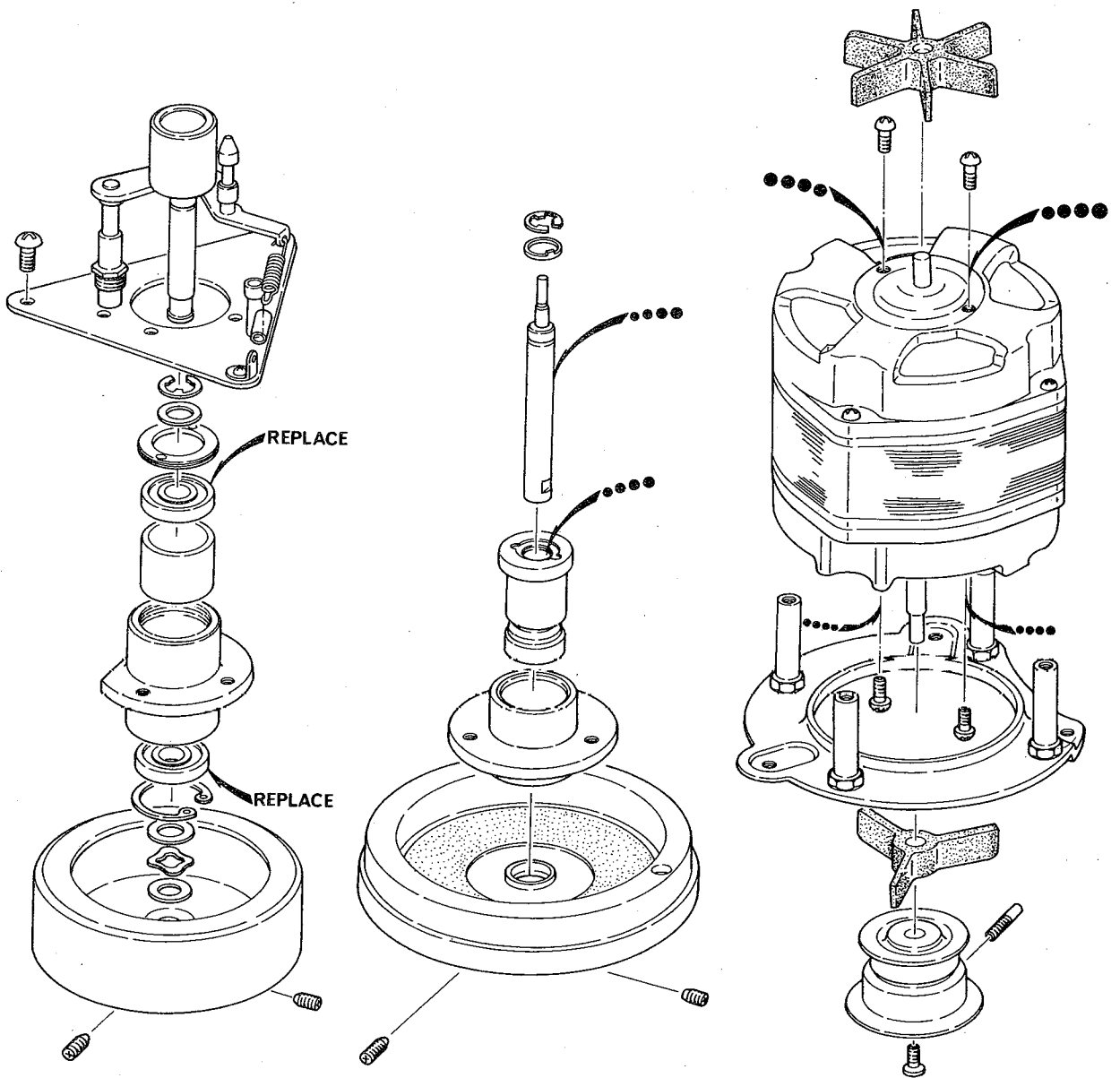



# X. TROUBLE SHOOTING CHART

## SECTION "A" TAPE TRANSPORT MECHANISM TROUBLES

- \* If all relays do not operate, first, check the REMOTE DUMMY PLUG (P202).
- \* Next, check D10D (D44-7) (Relay, Power Supply) and Condenser 220  $\mu$ F or 100  $\mu$ F 150V.
- \* Check the Relay Print Circuit Board as shown in Fig. First, check each connection point (blank point).
- \* When there are no troubles that relays and diodes have the normal resistances and distortions.

### 1. Capstan fails to rotate.

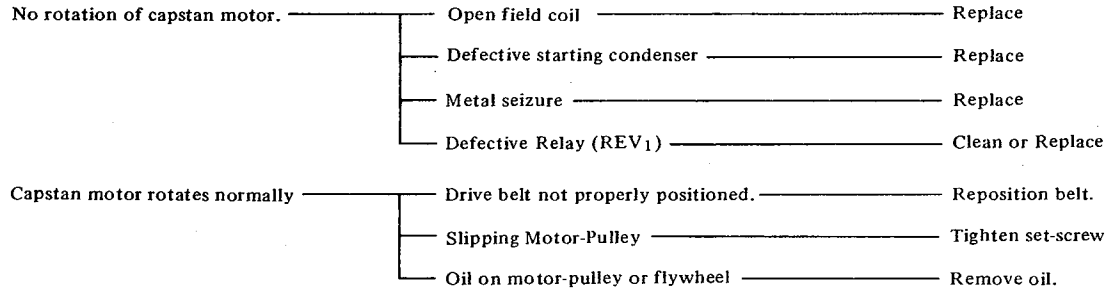

### 2. No tape movement in "Play" mode.

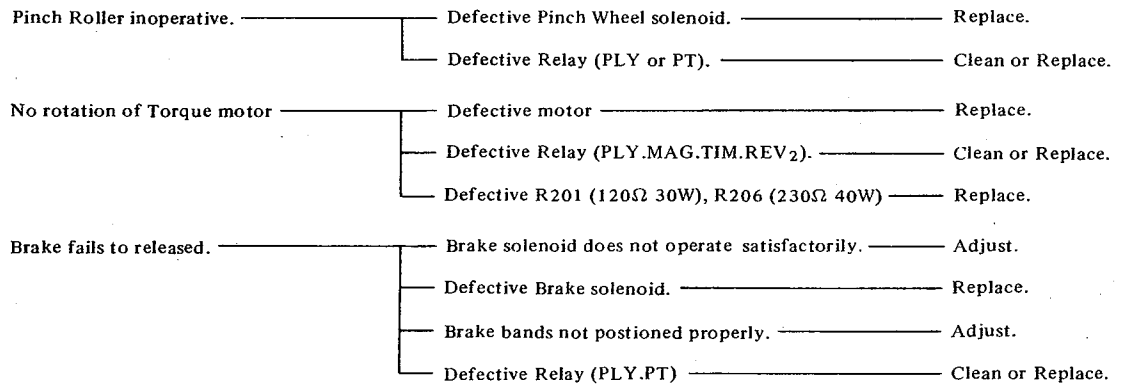

### 3. No "Reverse Play"

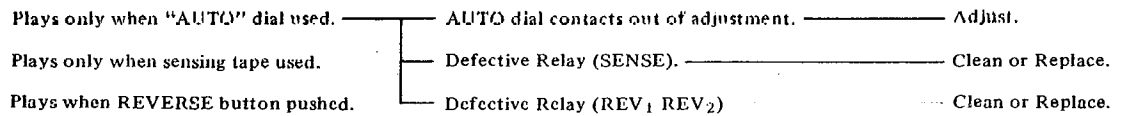

### 4. Inproper Reverse Operation

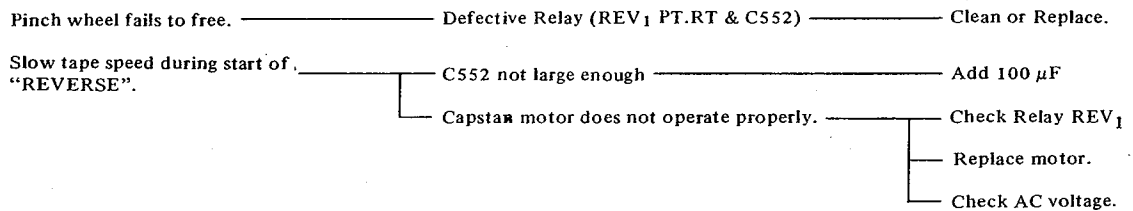

### 5. No rewind.

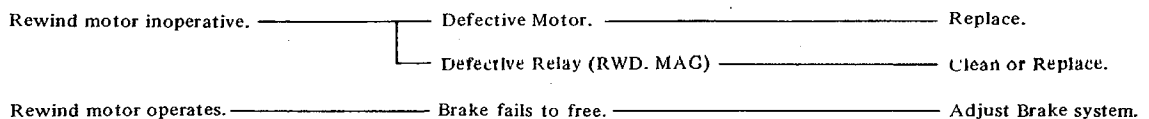



Intermittent sound cut out. ———— Defective Relay (REV. PL22-2) ———— Clean or Replace.  
 ———— Poor contact on Track Selector Card (RD-522) ———— Repair

2. Distorted sound

Satisfactory sound from Line-out. ———— Defective transistor or C.R. on RD-531. ———— Replace.  
 Sound distorted from Line-out. ———— Defective playback card components (RD-529). ———— Replace.  
 ———— Excessive playback head wear. ———— Replace.

3. Excessive Hum.

Hum decreased when playback head shorted. ———— Defective playback head. ———— Replace.  
 Hum not due to playback head. ———— Defective power supply circuit parts. ———— Replace.  
 ———— Broken or disconnected ground wire. ———— Repair.

4. Scratching or cracking sounds.

Noise during tape operation. ———— Magnetized head. ———— Demagnetize head.  
 ———— Noisy tape. ———— Replace tape.  
 Not due to tape. ———— Defective transistors on the playback card. ———— Replace.

5. Normal Reverse sound unequal

Head alignment. Incorrect height. adjustment. ———— Readjust or Replace head.

6. Improper function of dust minder

Lamp keeps lighting or remains lit. ———— Transistor or C7-2 defective on the Detector Card ———— Replace.  
 ———— Incorrect adjustment of VR71 1 10K ———— Readjust.  
 Lamp fails to light. ———— Defective lamp ———— Replace.

**B. Recording system troubles.**

\* Before any trouble shootings, clean and demagnetize heads first.

1. Recording not possible.

Recording lamp fails to light. (OSC does not work.) ———— Defective relay RL-44-4 (REC<sub>1</sub>) ———— Clean or Replace.  
 ———— Defective transistors or the OSC card (RD-530) ———— Replace.

Recording lamp lights. ———— Defective relay RL2201 (REC<sub>2</sub>) ———— Clean or Replace.  
 ———— Bias head does not shift to correct position. ———— Replace or Adjust bias solenoid.  
 VU meter indicates normal. ———— Defective head. ———— Replace.  
 ———— Defective transistors on the record card. ———— Replace.  
 No VU meter indication. ———— Defective transistors on the record card (RD-528) ———— Replace.

2. No VU meter indication.

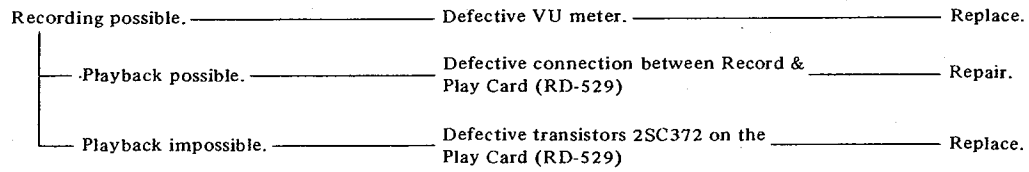

3. Distorted sound.

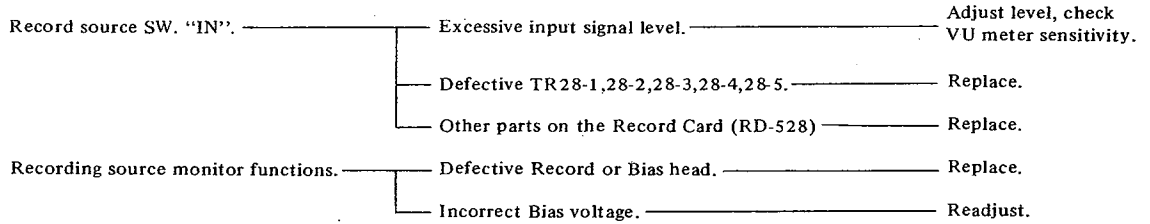

4. Faulty Erasing

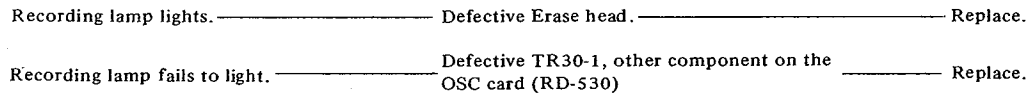

5. Inproper function of Auto VR

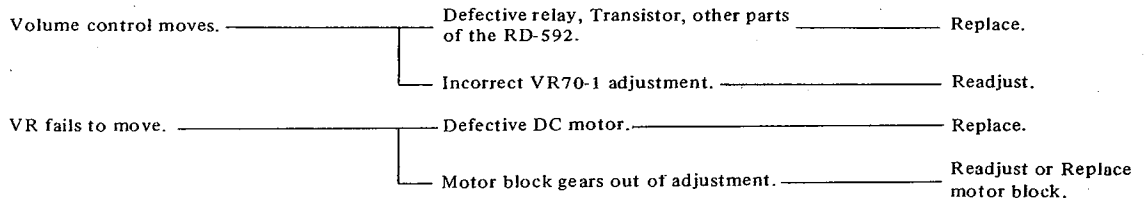

---

**MEMO**

## XI. COMPOSITE VIEWS OF COMPONENTS

---

	Page
SYSTEM CONTROL P.C. BOARD	RD-144 ..... 38
POWER SOURCE P.C. BOARD	RD-141 ..... 39
OSCILLATOR P.C. BOARD	RD-530 ..... 39
AUTOMATIC DUST MINDER P.C. BOARD	RD-271 ..... 40
PLAYBACK P.C. BOARD	RD-529 ..... 40
RECORDING P.C. BOARD	RD-528 ..... 41
MAIN AMP. P.C. BOARD	RD-531 ..... 41
MONITOR SWITCH P.C. BOARD	RD-523 ..... 42
TRACK SELECTOR P.C. BOARD	RD-522 ..... 42
COM. P.C. BOARD	RD-570 ..... 43
COM. SET SWITCH P.C. BOARD	RD-525 ..... 43
COM. MECHANIC P.C. BOARD	RD-529 ..... 43
SPARK QUENCHER P.C. BOARD	RD-150B ..... 44
SPEED SELECTOR SWITCH P.C. BOARD	RD-139B ..... 44
HEADPHONE P.C. BOARD	RD-524 ..... 45
CHASSIS P.C. BOARD	RD-526 ..... 45
MAIN AMP SOCKET P.C. BOARD	RD-532 ..... 45

SYSTEM CONTROL P.C. BOARD (RD-144)

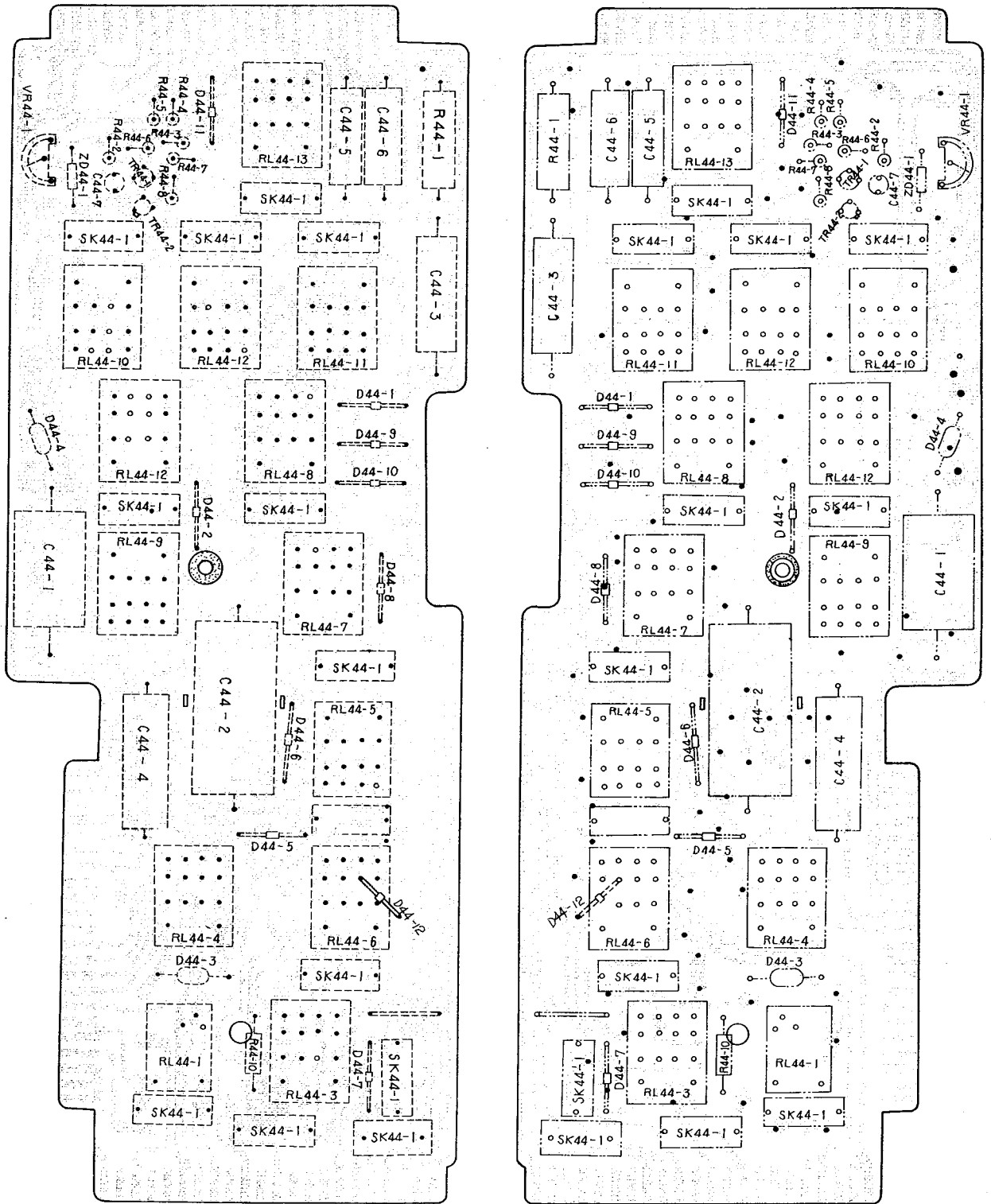

POWER SOURCE P.C. BOARD (RD-141)

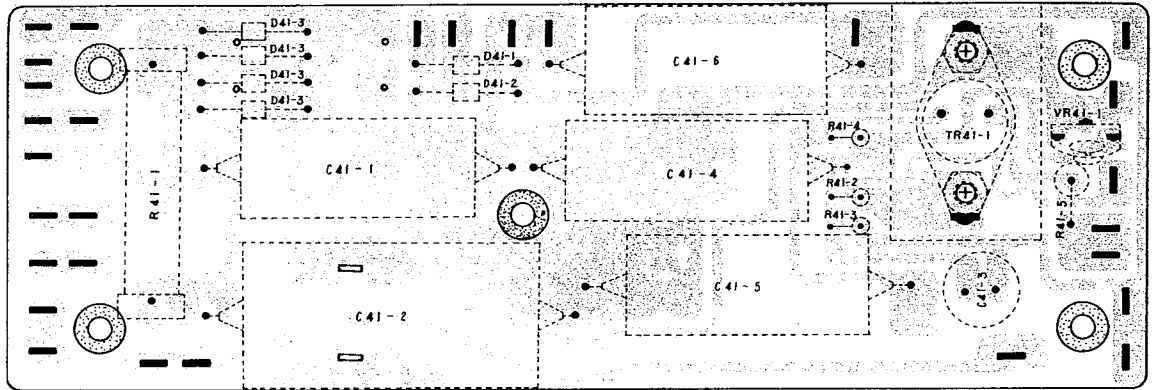

OSC. P.C. BOARD (RD-530)

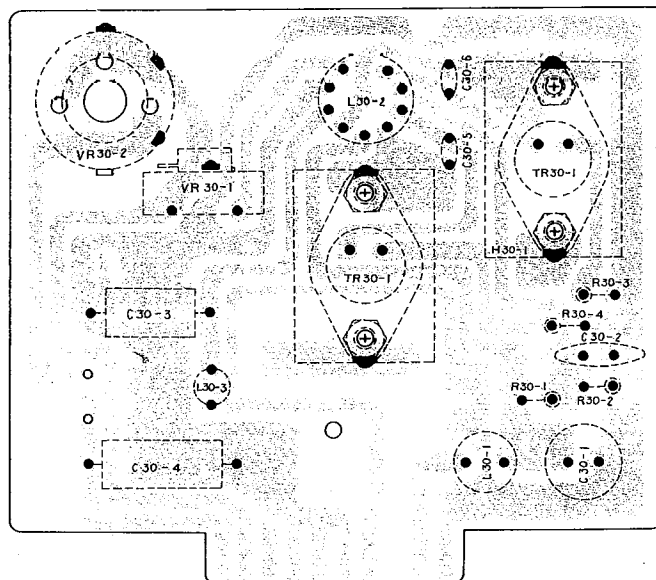



AUTOMATIC DUST MINDER P.C. BOARD (RD-271)

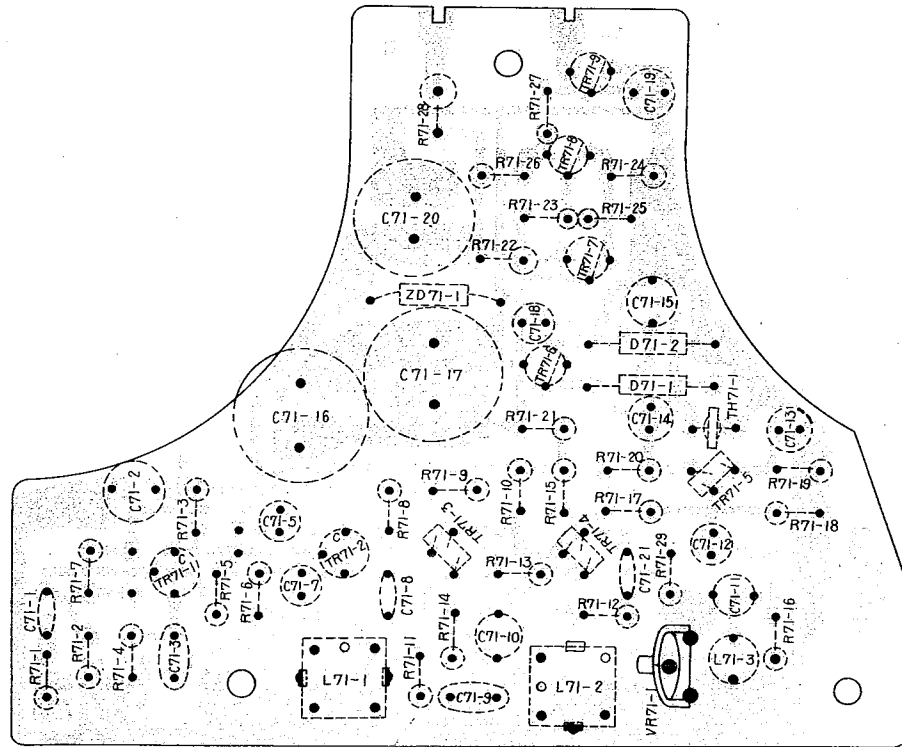

PLAYBACK P.C. BOARD (RD-529)

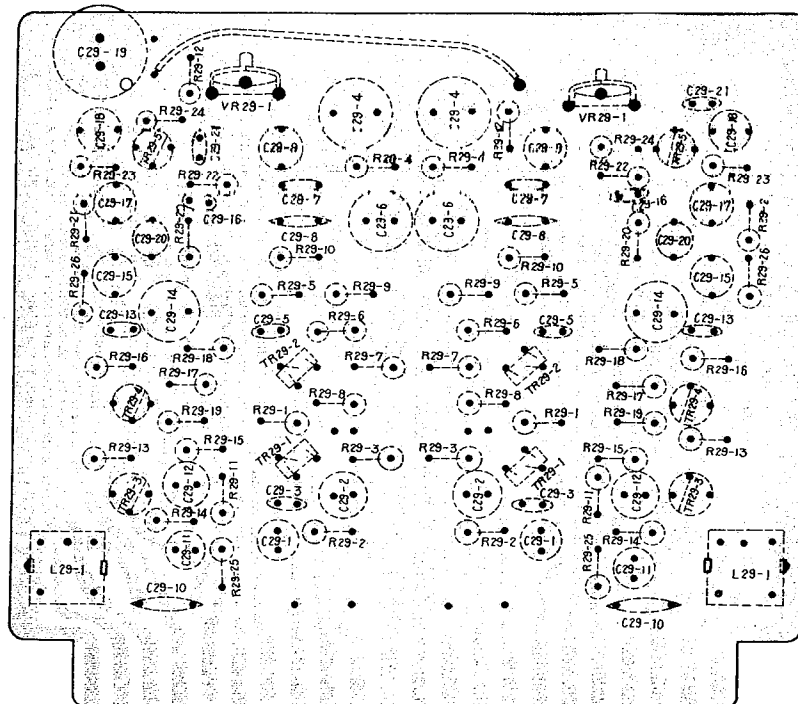

RECORDING P.C. BOARD (RD-528)

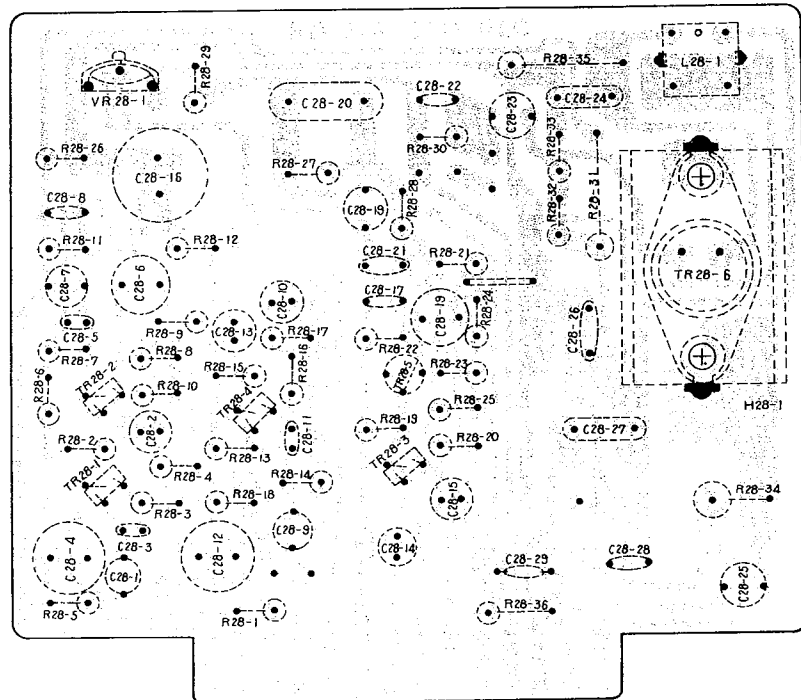

MAIN AMP. P.C. BOARD (RD-531)

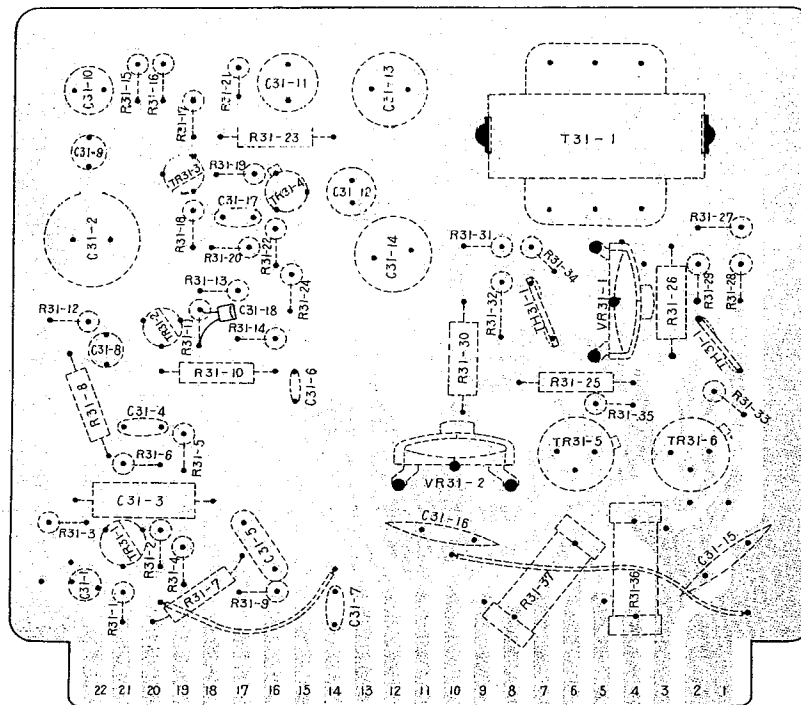

MONITOR SWITCH P.C. BOARD (RD-523)

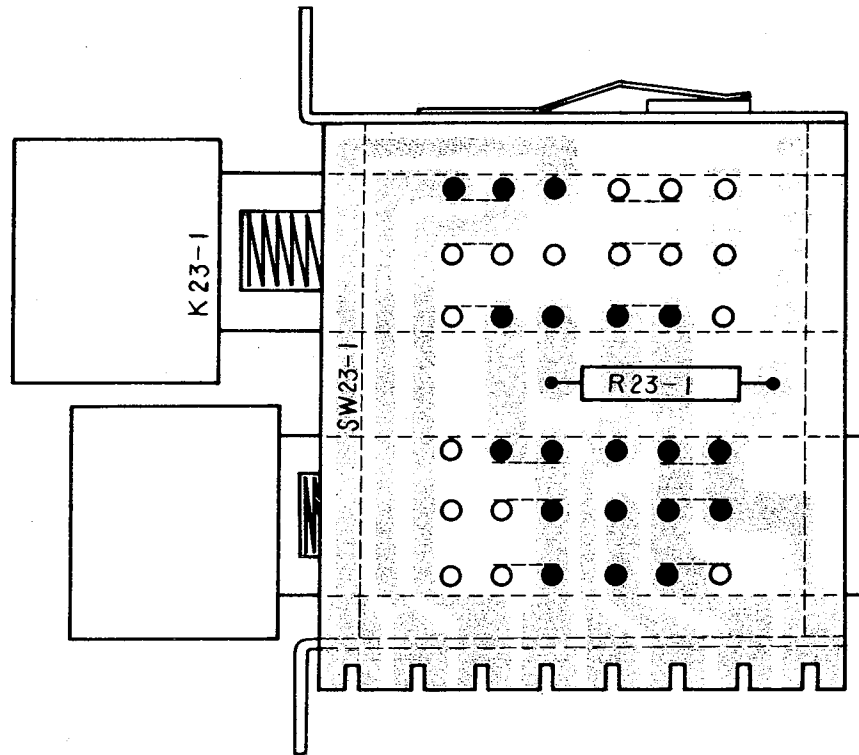

TRACK SELECTOR P.C. BOARD (RD-522)

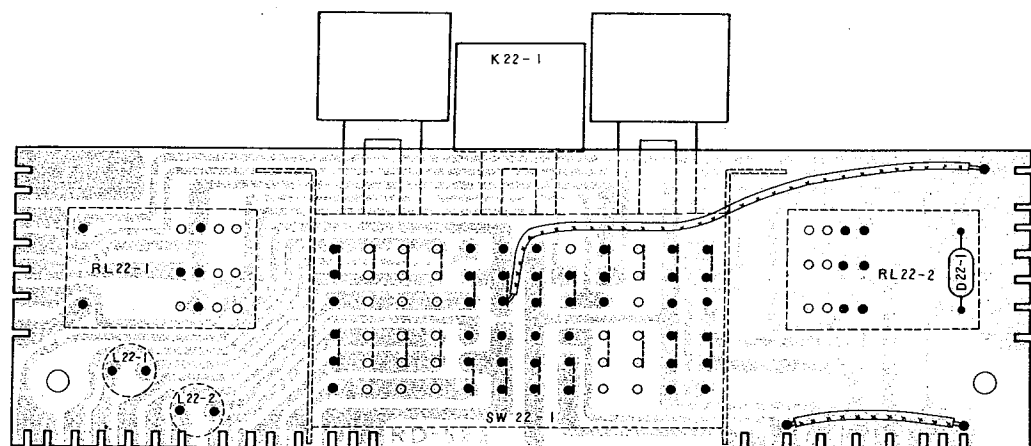

COM. P.C. BOARD (RD-570)

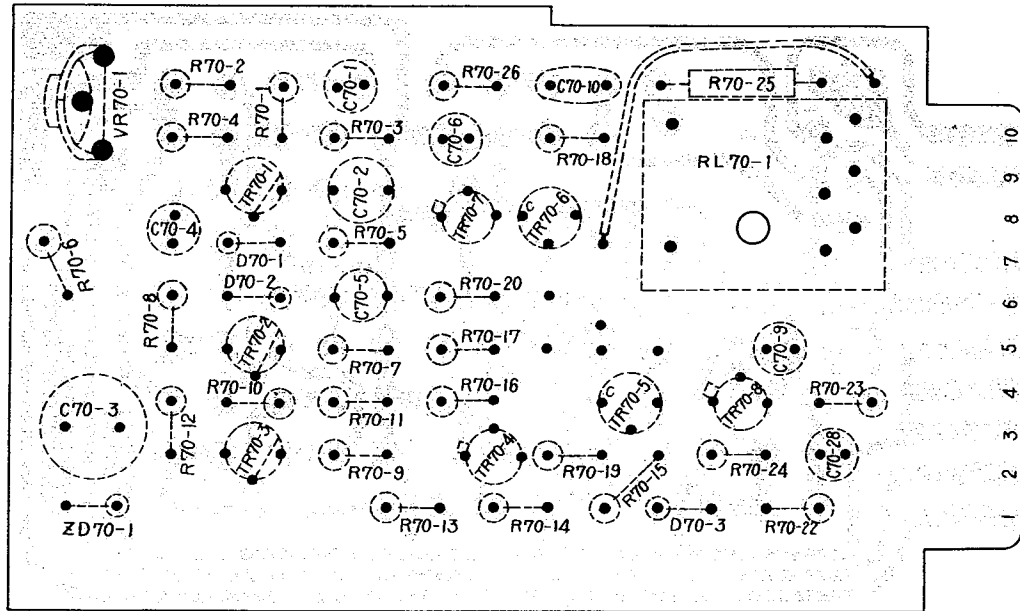

COM. SET SWITCH P.C. BOARD (RD-525)

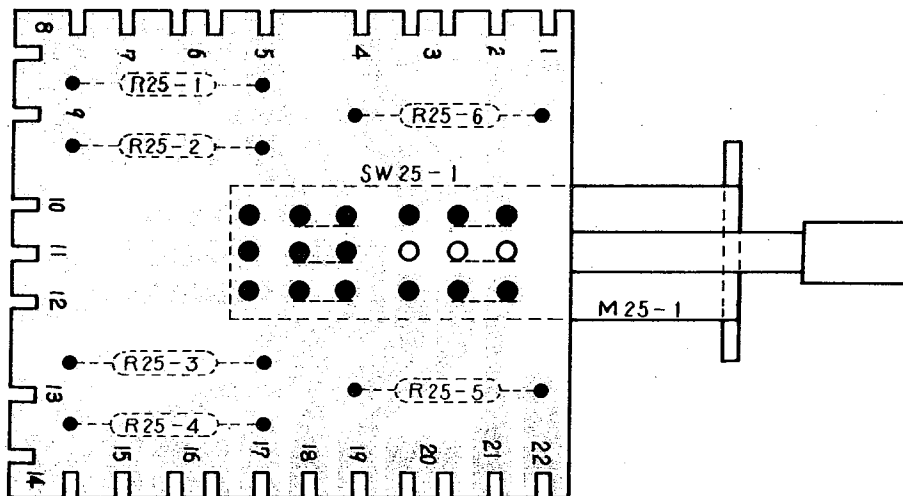

COM. MECHANISM P.C. BOARD (RD-592)

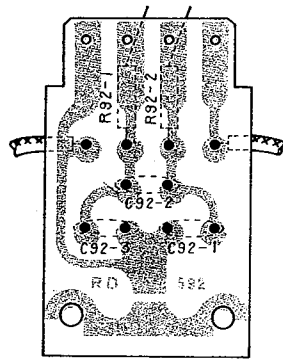

SPARK QUENCHER P.C. BOARD (RD-150B)

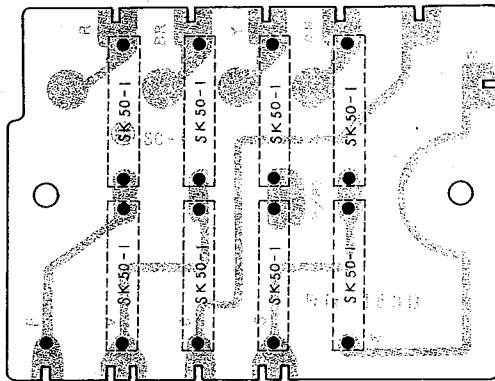

SPEED SELECTOR SWITCH P.C. BOARD (RD-139B)

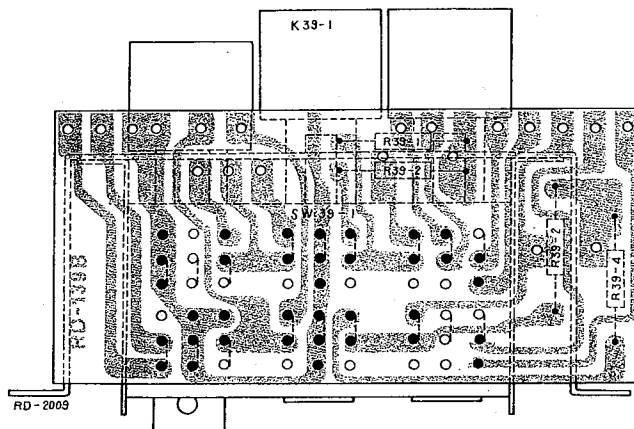

HEADPHONE P.C. BOARD (RD-524) (X-360 D only)

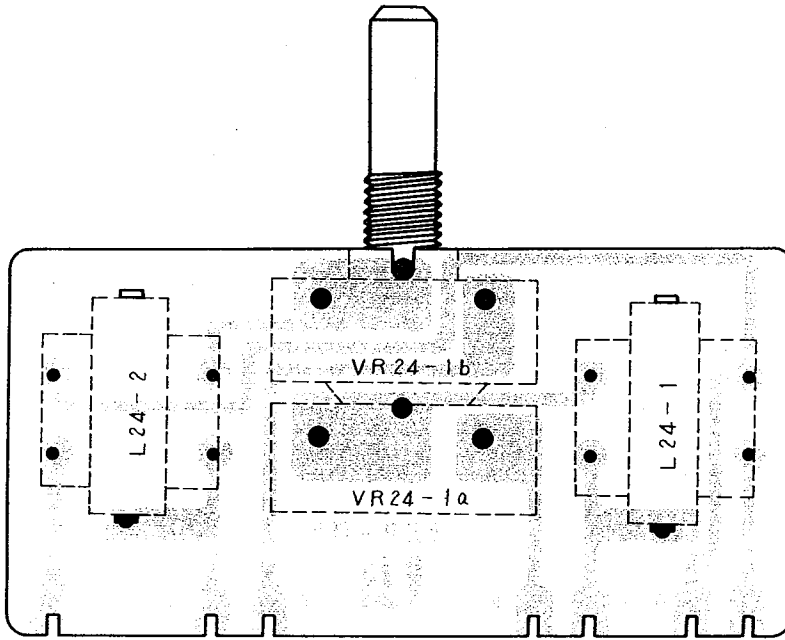

CHASSIS P.C. BOARD (RD-526)

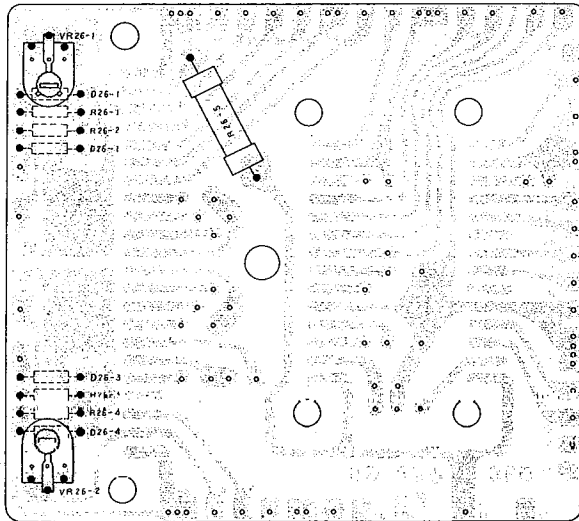

MAIN AMPLIFIER SOCKET P.C. BOARD (RD-532)

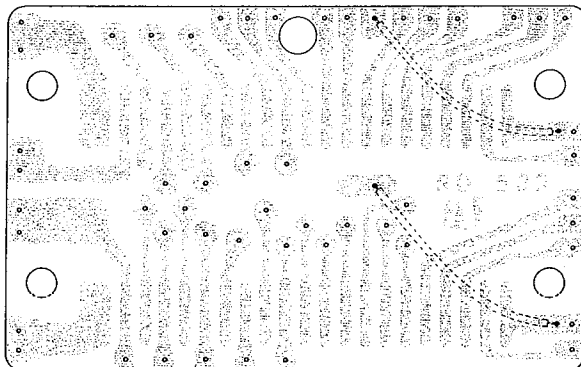

## XII. SCHEMATIC DIAGRAM NUMBER CLASSIFICATION

Schematic Diagram Number Classification according to Serial Numbers.

### X-360

Serial Number	REC. RD528	P.B. RD529	OSC. RD530	DM RD271	COM RD570	PWR/AMP RD531	SYSCON RD144	AMP CHASSIS
710-0001 – 710-0500	R-1	P-1	O-1	D-1	C-1	W-1	S-1	A-1
808-0001 – 808-0700	↓	↓	↓	↓	↓	↓	↓	↓
808-0701 – 808-1000	↓	↓	↓	D-2	↓	↓	↓	↓
808-1001 – 808-2000	R-2	↓	↓	↓	↓	↓	S-2	A-2
1204-0001 – 1204-1000	↓	↓	↓	↓	↓	↓	S-3	↓
103-0001 – 103-0800	R-3	P-2	O-2	↓	↓	↓	S-4	↓

### X-360D

Serial Number	REC. RD528	P.B. RD529	OSC RD530	DM RD271	COM RRD570	SYSCON RD144	AMP CHASSIS	
704-0001 – 704-0500	R-1	P-1	O-1	D-1	C-1	S-1	A-1	
807-0001 – 807-1500	↓	↓	↓	↓	↓	↓	↓	
904-0001 – 904-0440	↓	↓	↓	D-2	↓	↓	↓	
1006-0001 – 1006-0200	↓	↓	↓	↓	↓	↓	↓	
1102-0001 – 1102-0500	↓	↓	↓	↓	↓	↓	↓	
1203-0001 – 1203-1000	R-2	↓	↓	↓	↓	S-3	A-2	
102-0001 – 102-1200	R-3	P-2	O-2	↓	↓	S-4	↓	

**\* NOTE**

#### INTERCHANGEABILITY

1. There are three types of Recording Amplifier Boards (RD-528). They are no interchangeable.
2. The SYSCON board (RD-144) is interchangeable only when the new board is installed on an old tape recorder.
3. All other boards are interchangeable.
4. Amp. Chassis is no interchangeable.

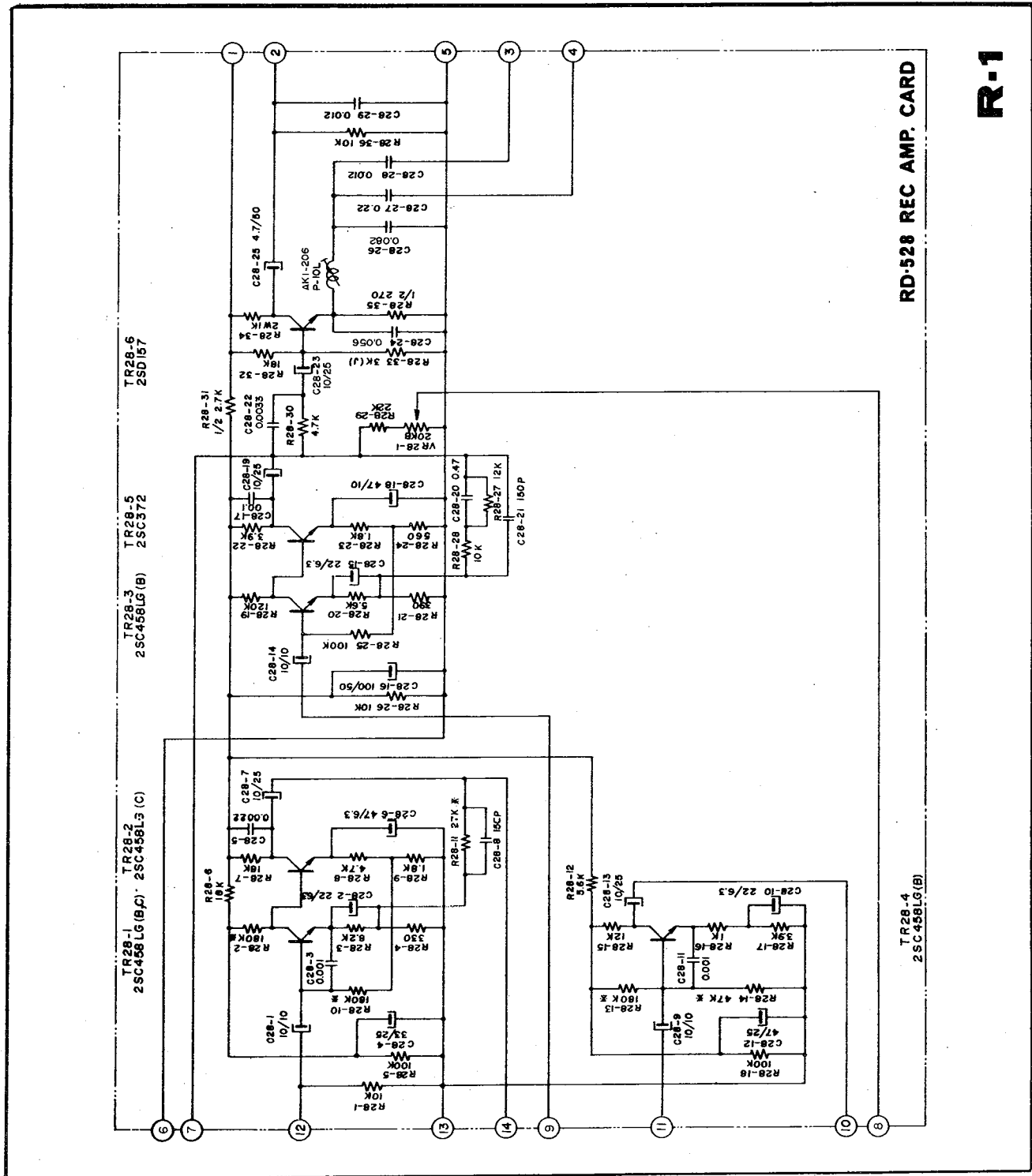

RD-528 REC AMP. CARD

R-1



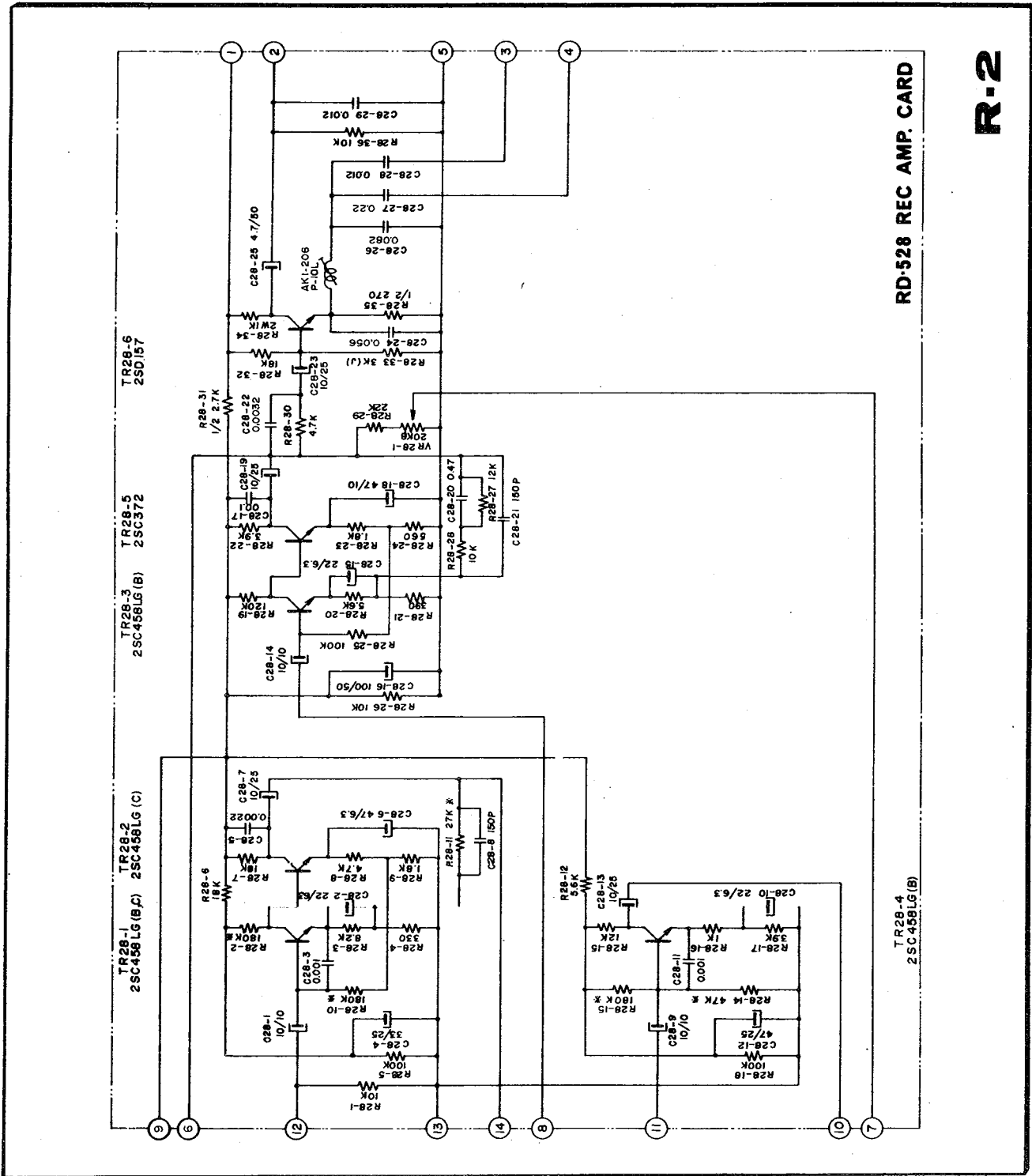

RD-528 REC AMP. CARD

TR28-4  
2SC458LG(B)

TR28-6  
2SD157

TR28-5  
2SC372

TR28-2  
2SC458LG (C)

TR28-1  
2SC458LG (B) C

R-2

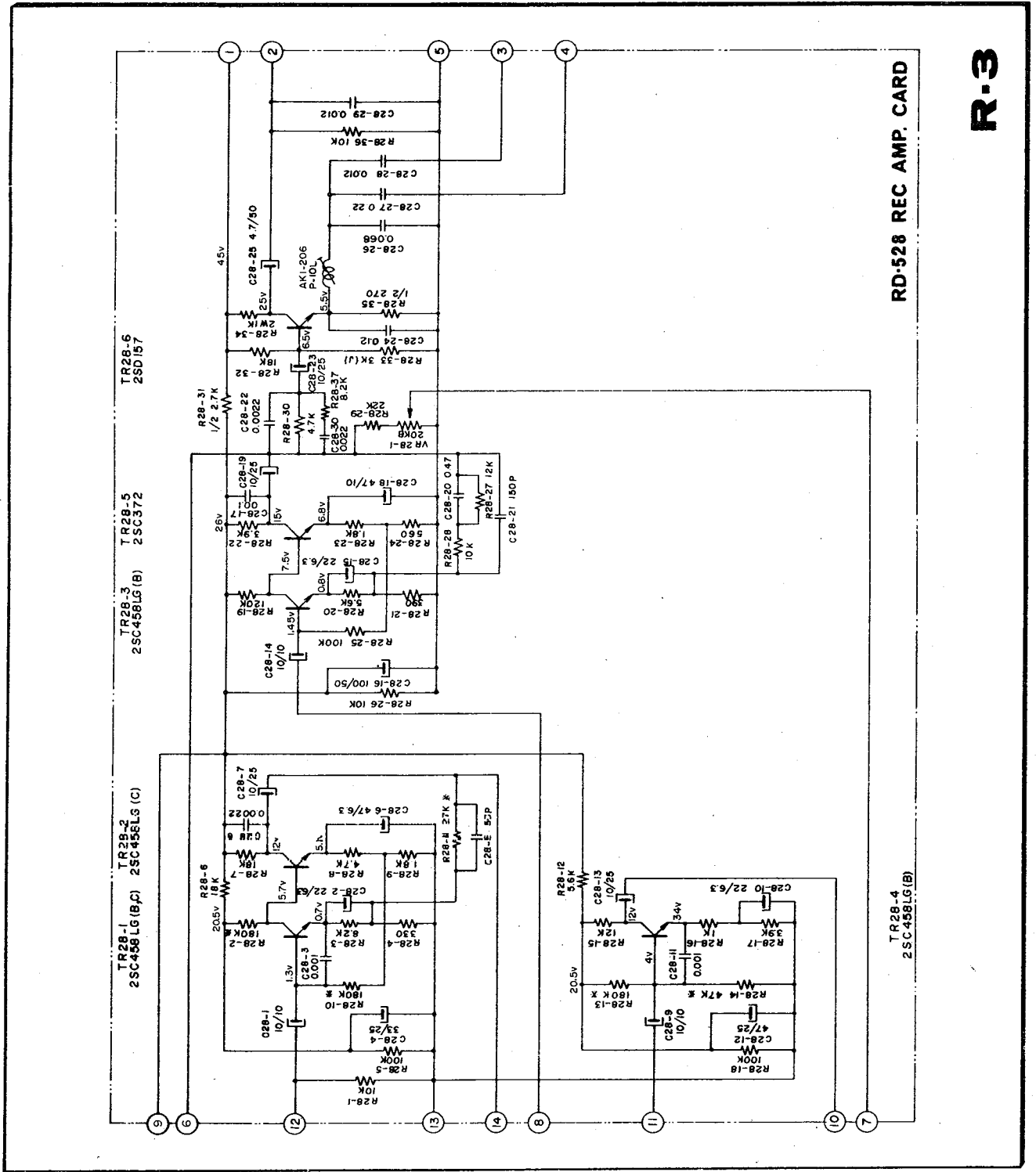

RD-528 REC AMP. CARD

R-3

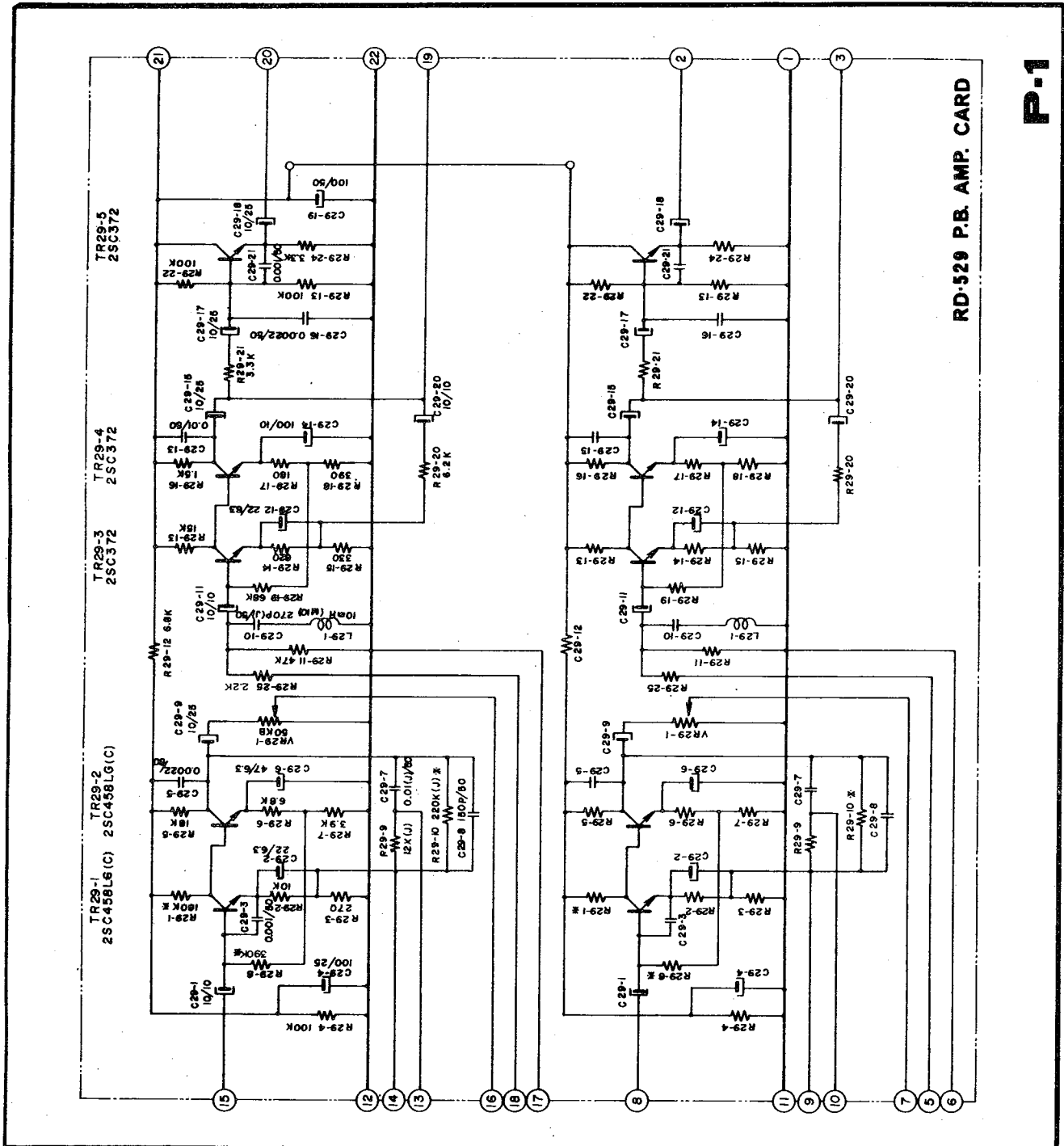

RD-529 P.B. AMP. CARD

P-1

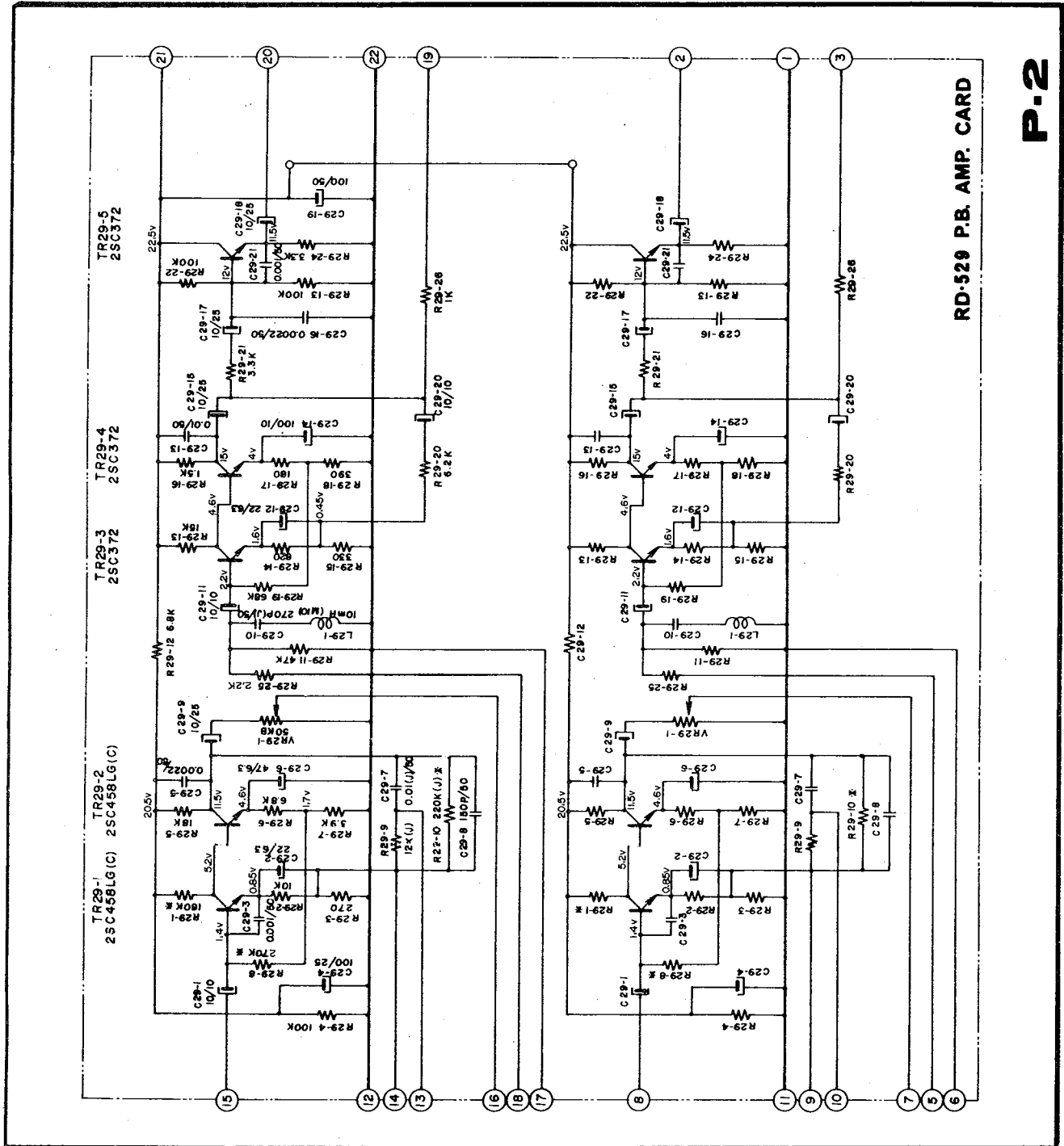

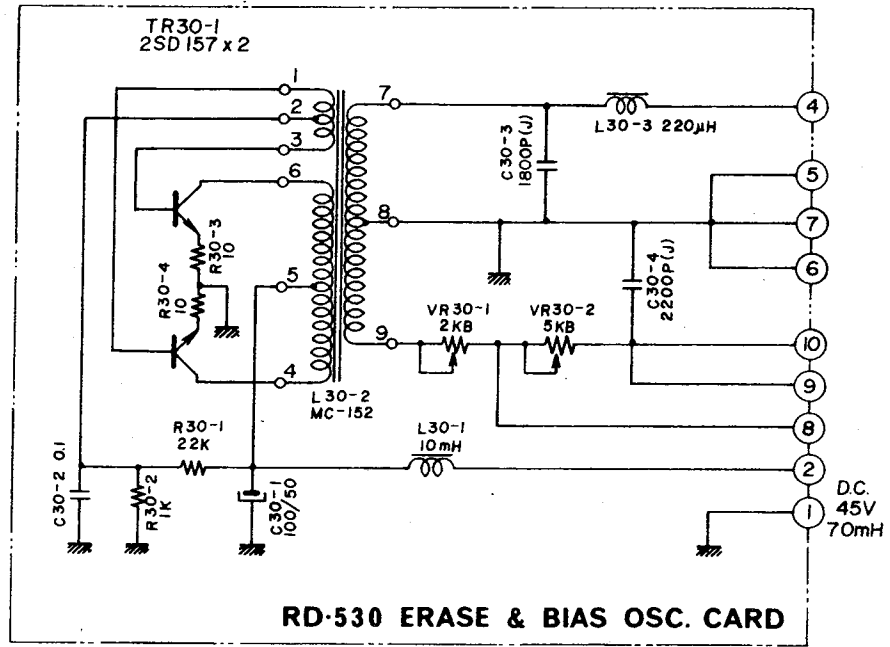

**O-1**

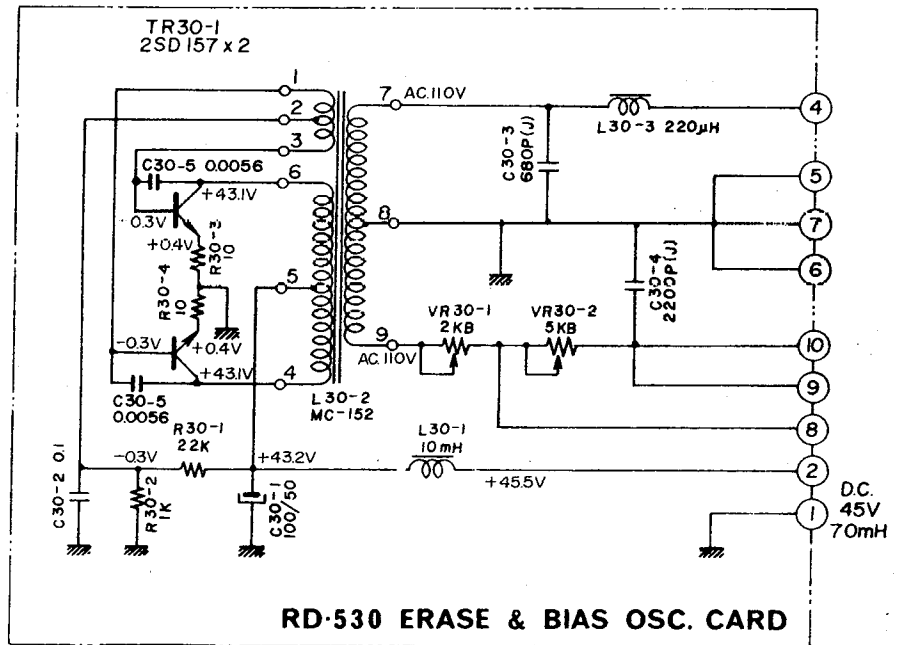

**O-2**

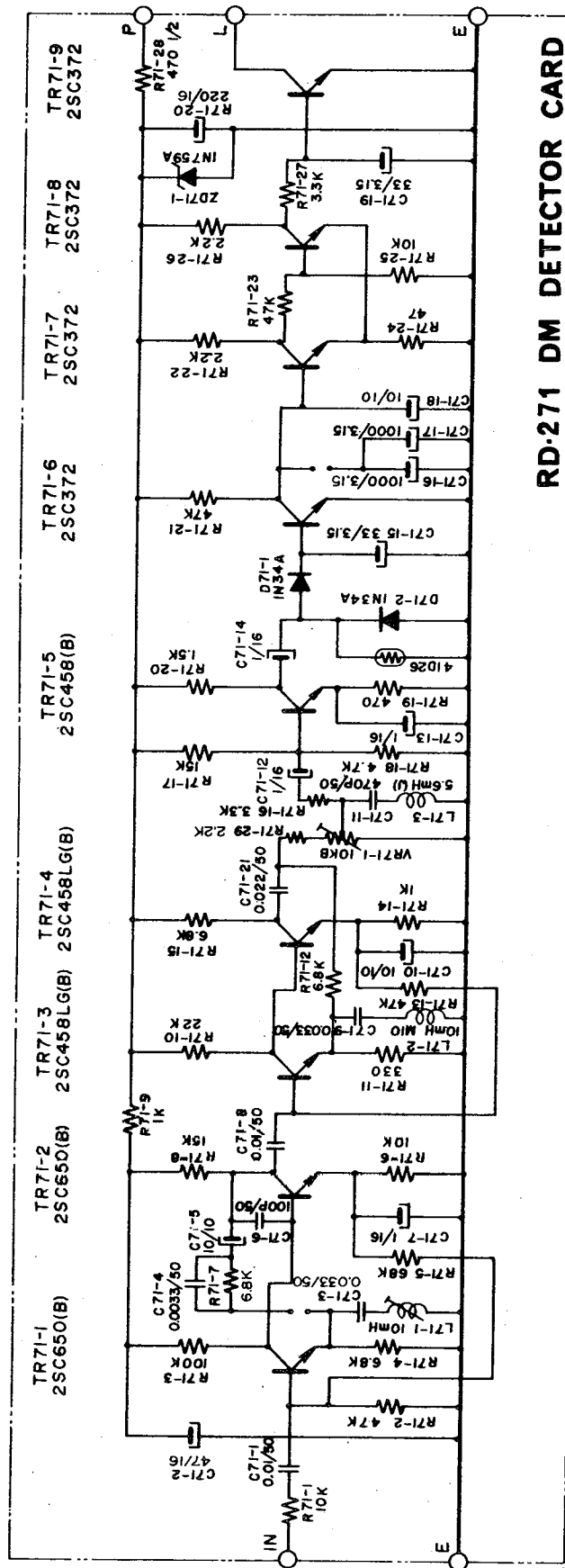

RD-271 DM DETECTOR CARD

D-1

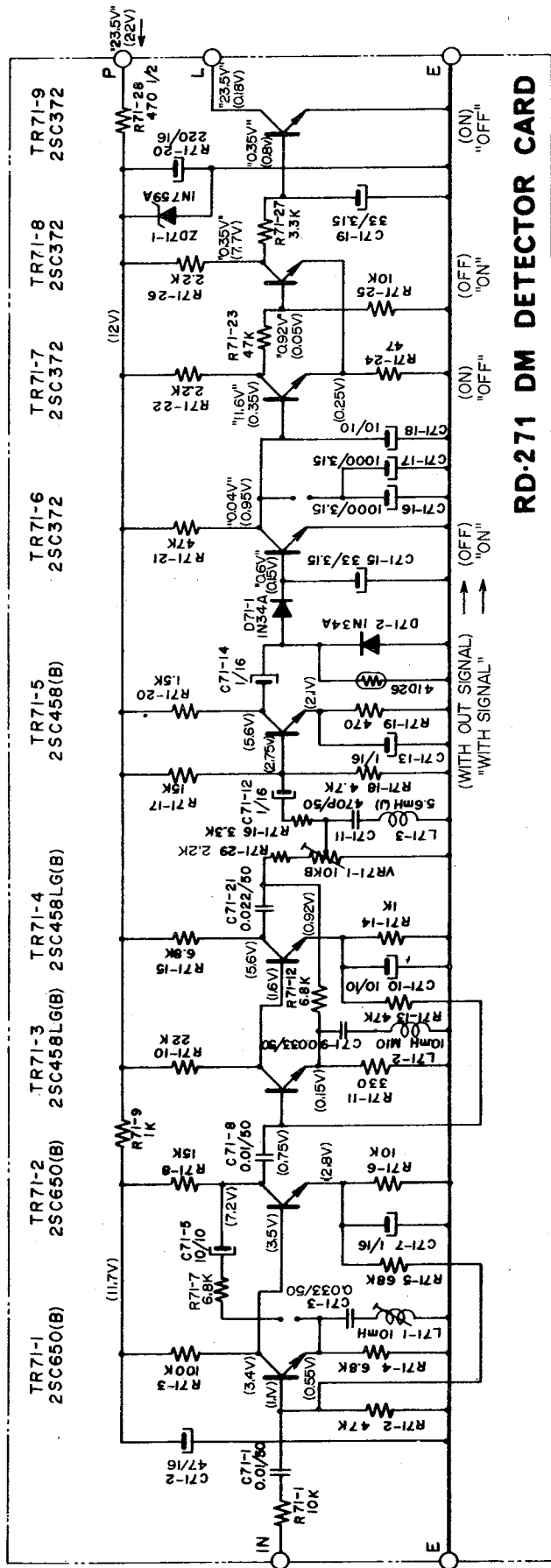

RD-271 DM DETECTOR CARD

( ) SHOWING LAMP IS ON  
 ( - - - ) SHOWING LAMP IS OFF

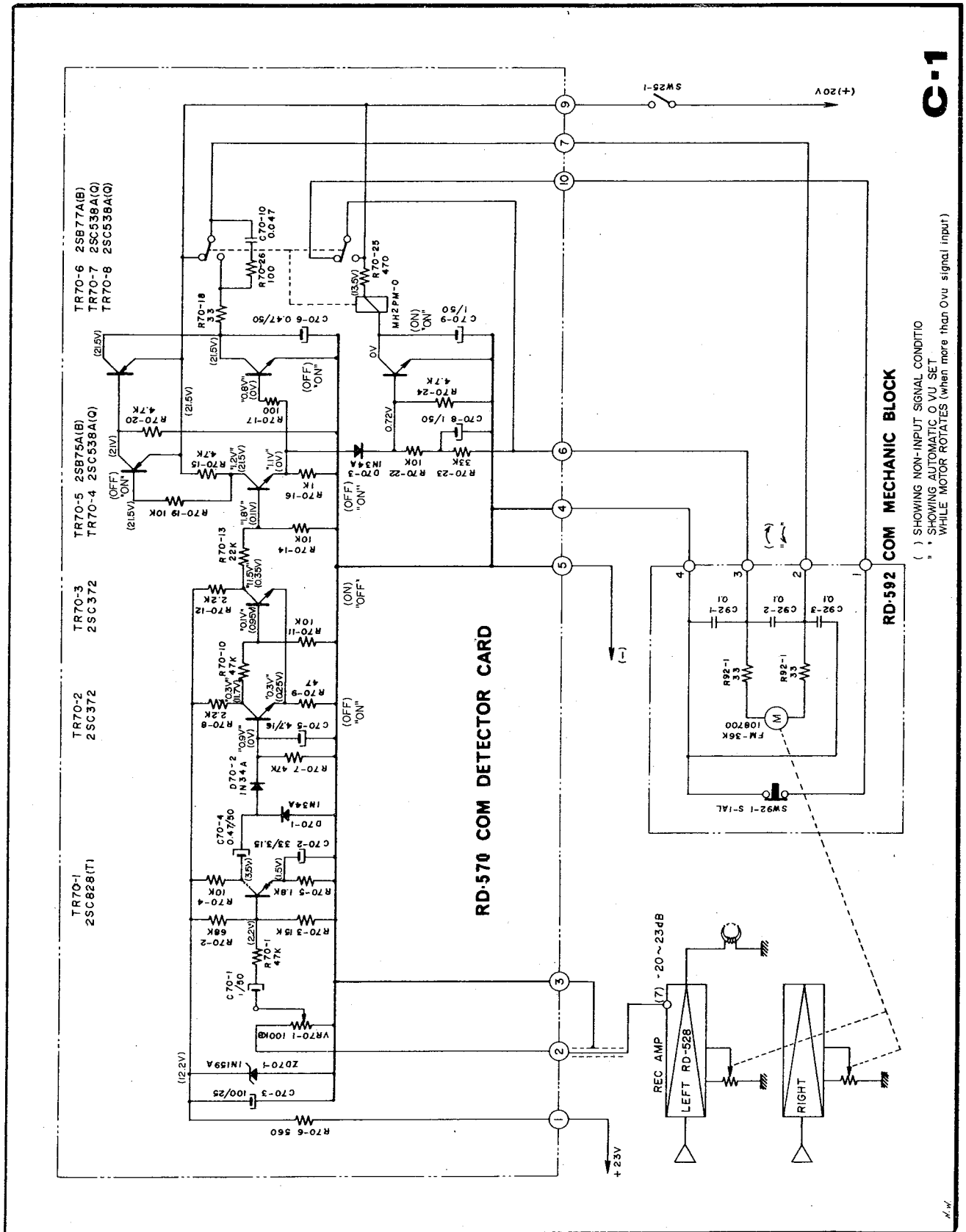



RD-531 POWER AMP. CARD

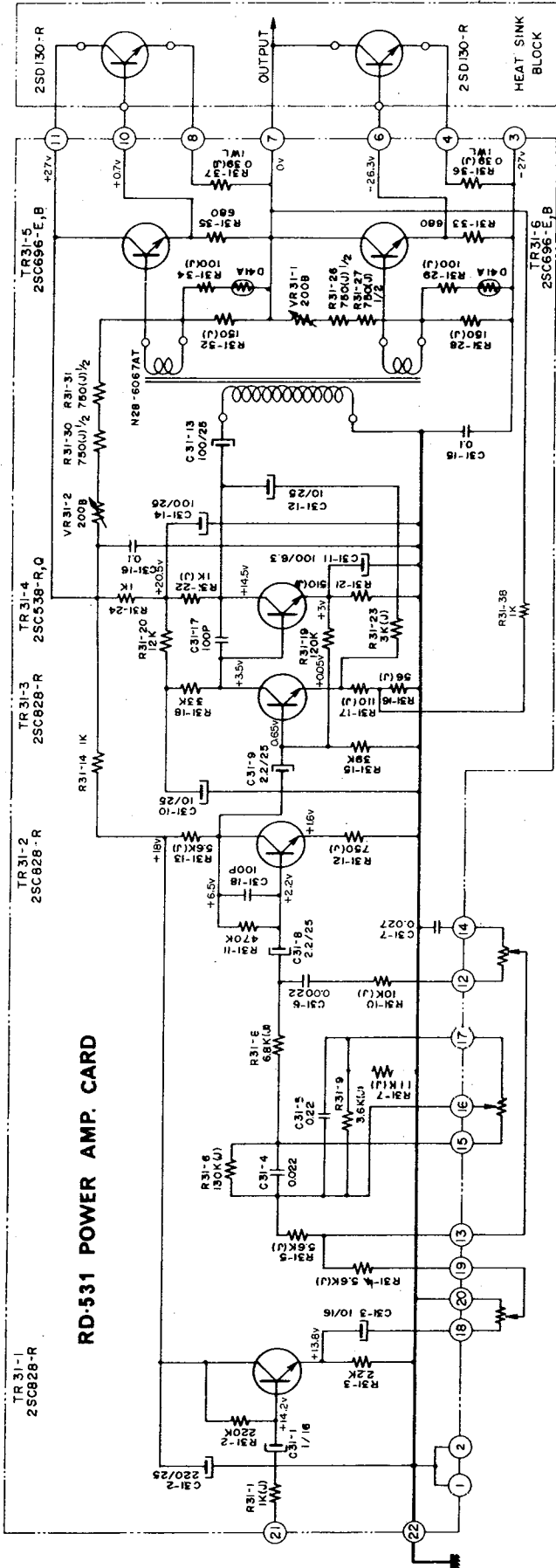

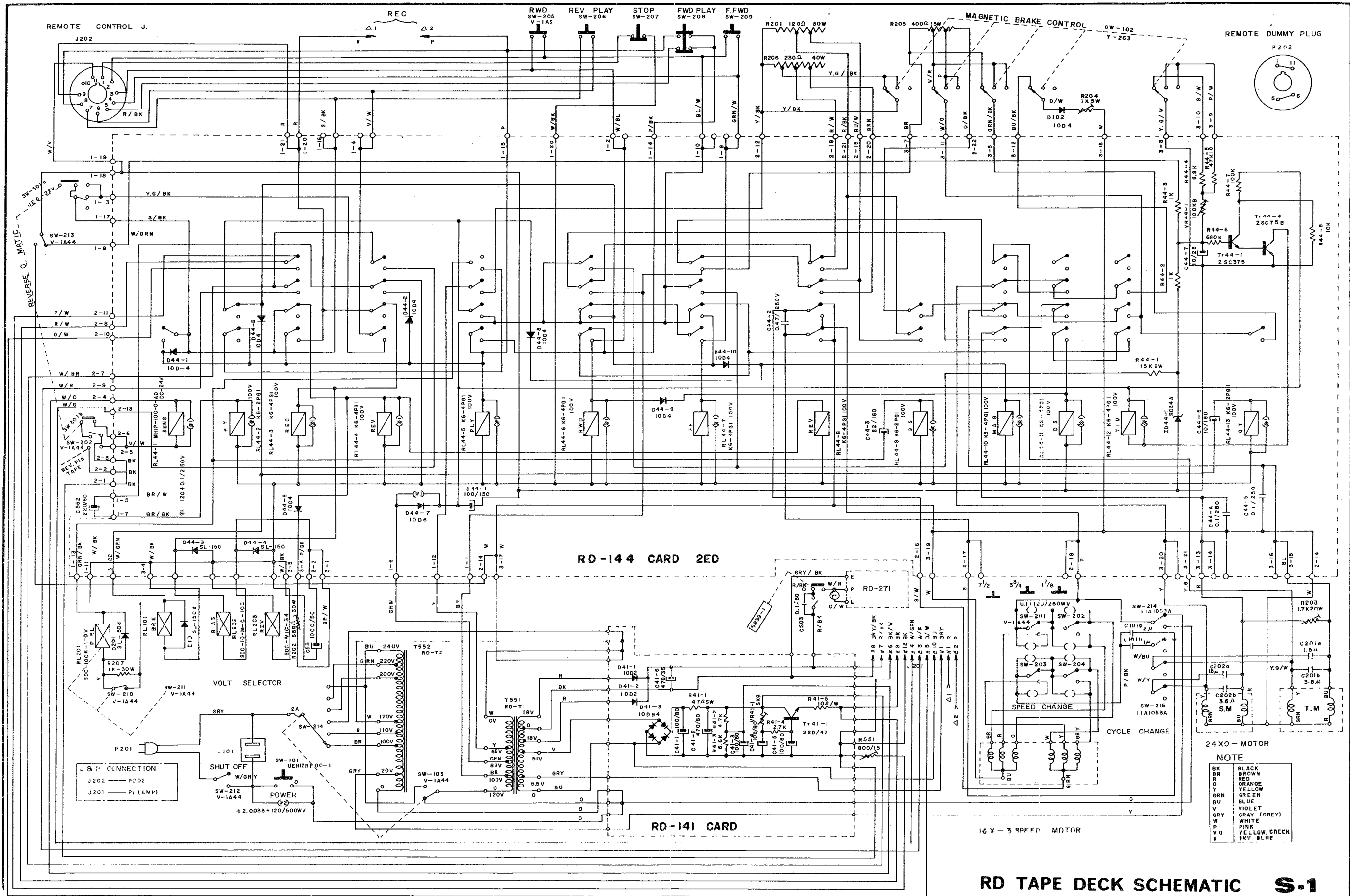

RD TAPE DECK SCHEMATIC S-1

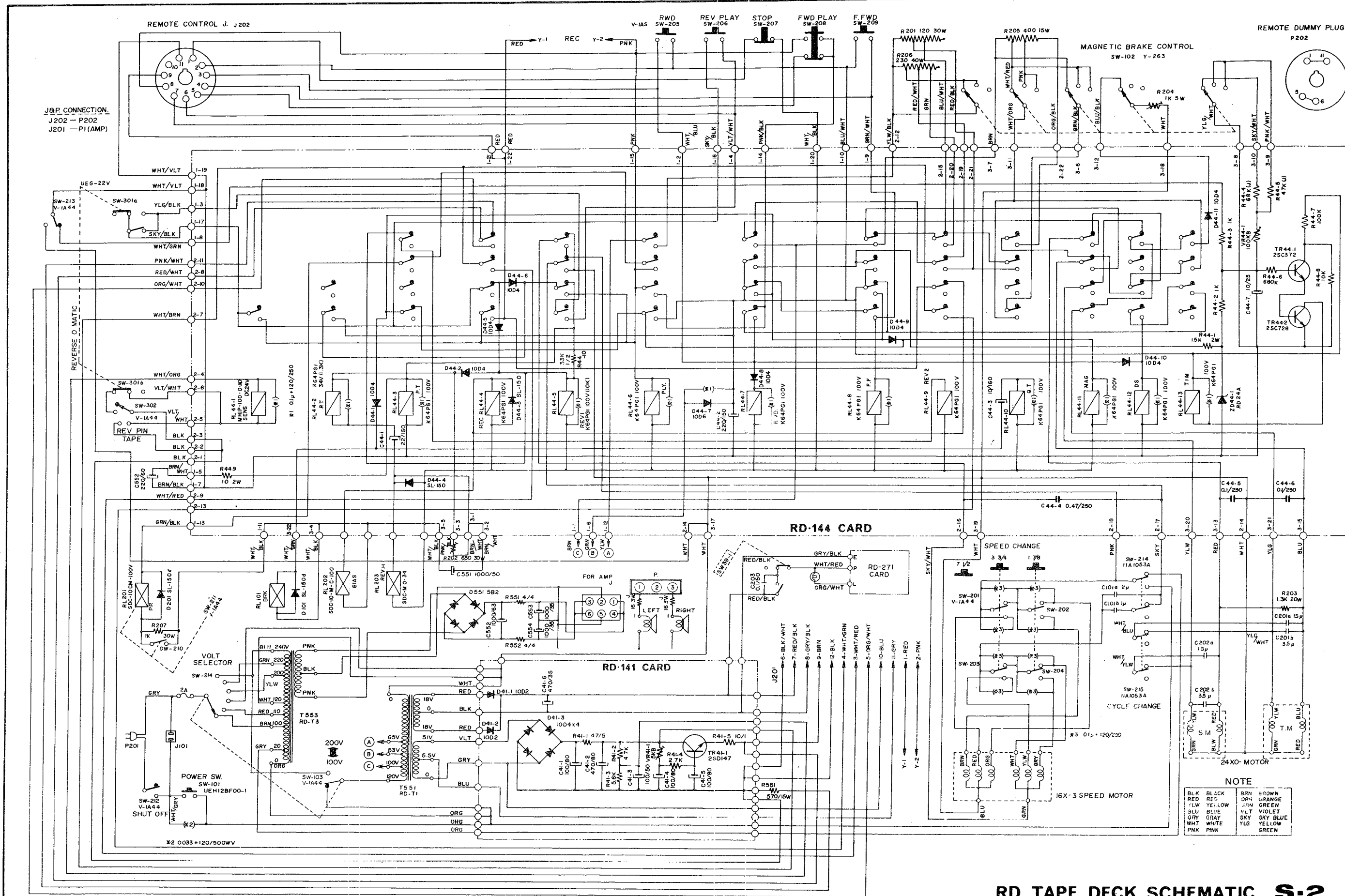

RD TAPE DECK SCHEMATIC S-2

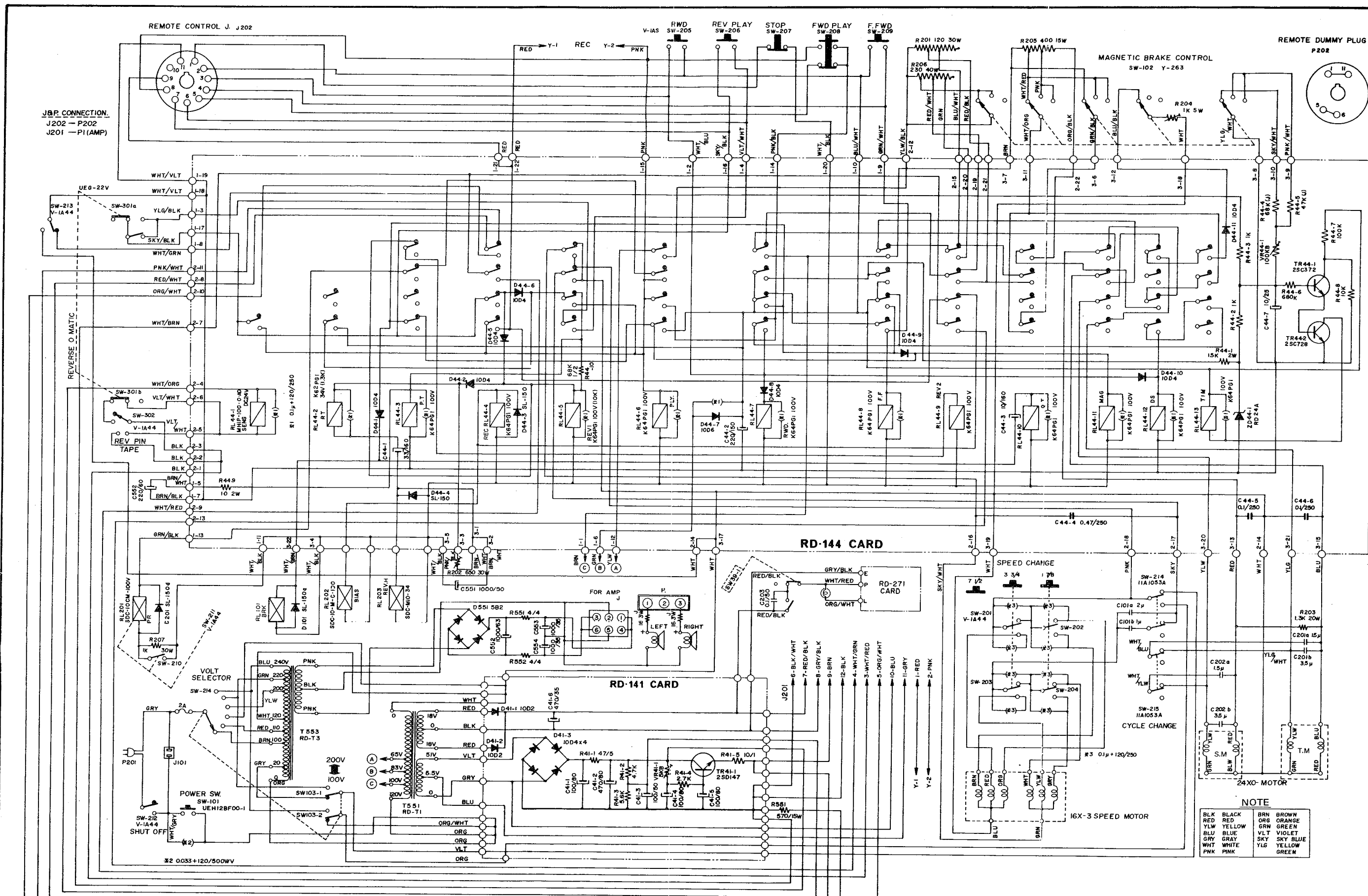

J&P CONNECTION  
 J202 - P202  
 J201 - P1 (AMP)

REMOTE DUMMY PLUG  
 P202

RD-144 CARD

RD-141 CARD

RD-271 CARD

SPEED CHANGE

CYCLE CHANGE

NOTE

BLK	BLACK	BRN	BROWN
RED	RED	ORG	ORANGE
YLG	YELLOW	GRN	GREEN
BLU	BLUE	VLT	VIOLET
GRY	GRAY	SKY	SKY BLUE
WHT	WHITE	YLG	YELLOW
PNK	PINK	GRN	GREEN

RD TAPE DECK SCHEMATIC S-3

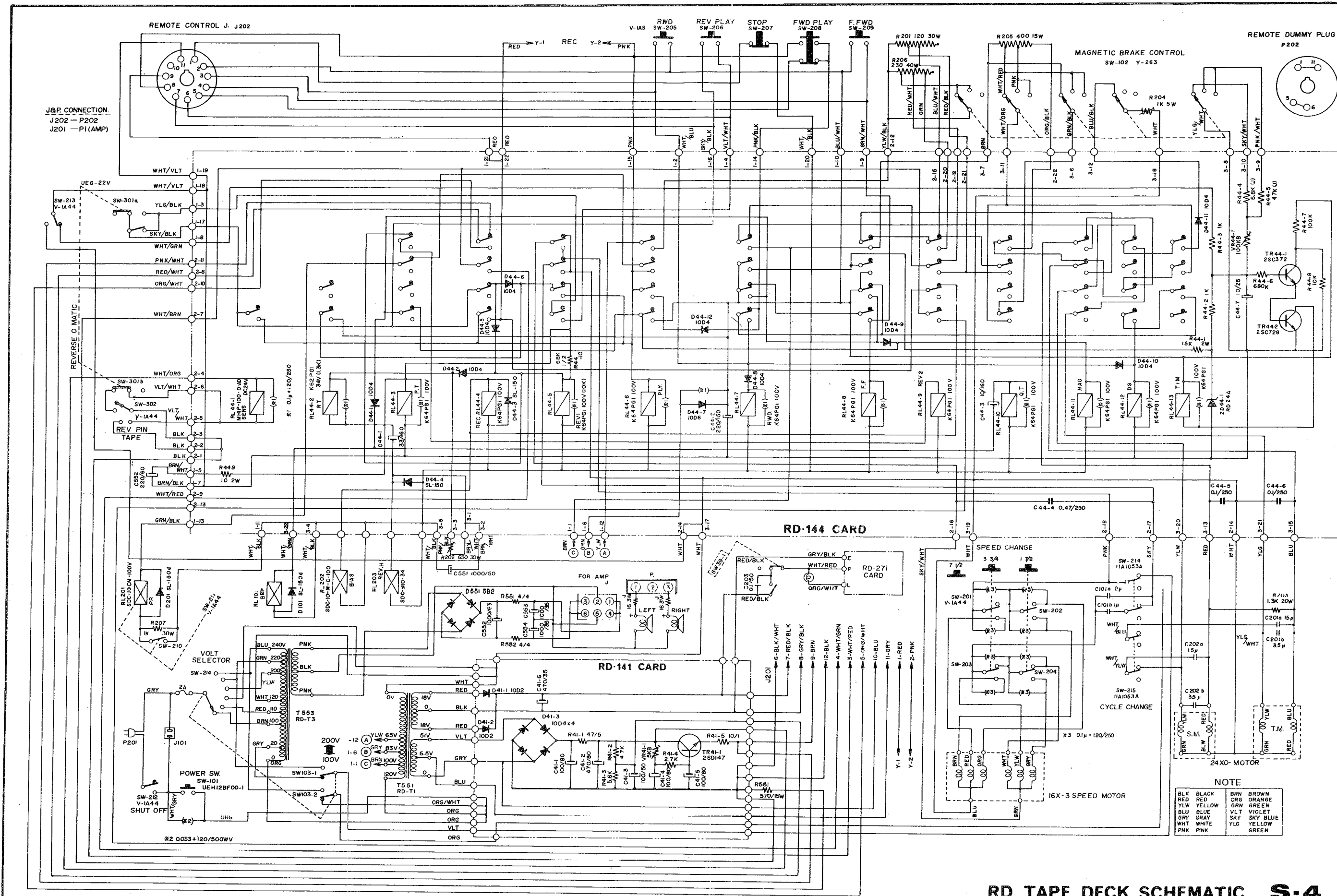

J&P CONNECTION  
 J202 - P202  
 J201 - P1 (AMP)

REMOTE DUMMY PLUG  
 P202

RD-144 CARD

RD-141 CARD

SPEED CHANGE

CYCLE CHANGE

NOTE

BLK	BLACK	BRN	BROWN
RED	RED	ORG	ORANGE
YLW	YELLOW	GRN	GREEN
BLU	BLUE	VLT	VIOLET
GRY	GRAY	SKY	SKY BLUE
WHT	WHITE	YLG	YELLOW GREEN
PNK	PINK		

RD TAPE DECK SCHEMATIC S-4

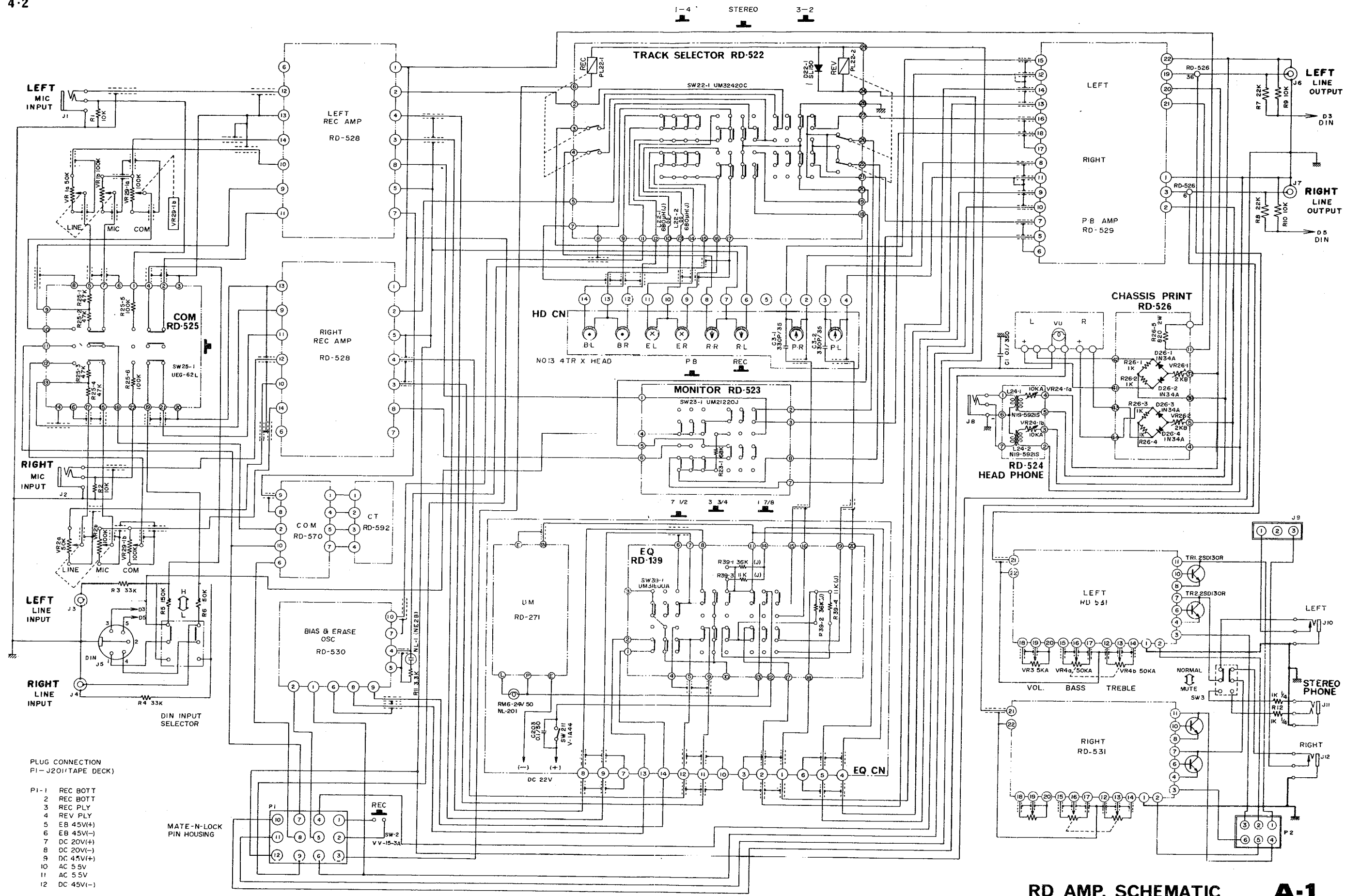

PLUG CONNECTION  
P1 - J201 (TAPE DECK)

- P1-1 REC BOTT
- 2 REC BOTT
- 3 REC PLY
- 4 REV PLY
- 5 EB 45V(+)
- 6 EB 45V(-)
- 7 DC 20V(+)
- 8 DC 20V(-)
- 9 DC 4.5V(+)
- 10 AC 5.5V
- 11 AC 5.5V
- 12 DC 45V(-)

MATE-N-LOCK  
PIN HOUSING

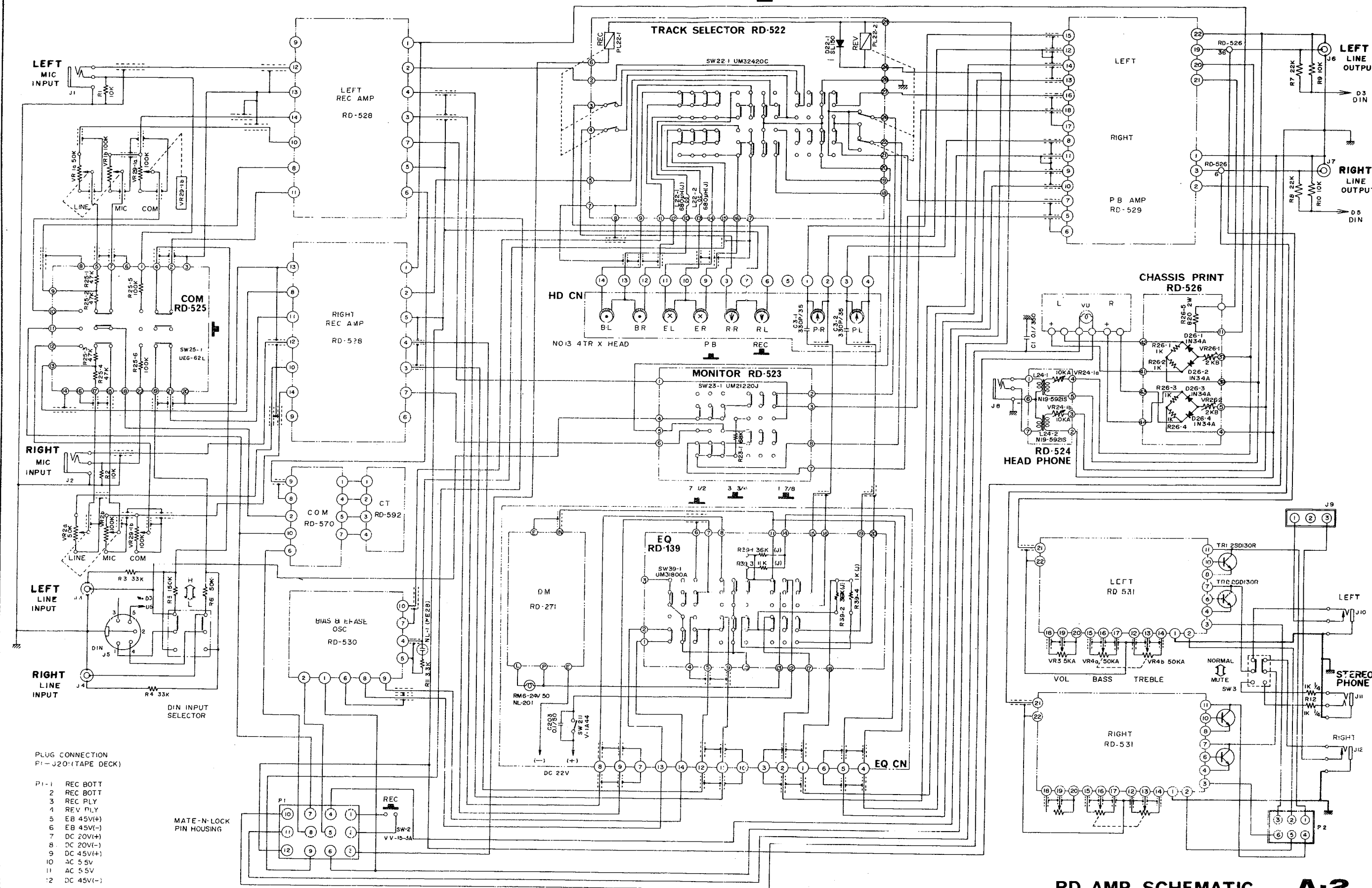

PLUS CONNECTION  
P1-J20 (TAPE DECK)

- P1-1 REC BOTT
- 2 REC BOTT
- 3 REC PLY
- 4 REV PLY
- 5 EB 45V(+)
- 6 EB 45V(-)
- 7 DC 20V(+)
- 8 DC 20V(-)
- 9 DC 45V(+)
- 10 AC 55V
- 11 AC 55V
- 12 DC 45V(-)

MATE-N-LOCK  
PIN HOUSING

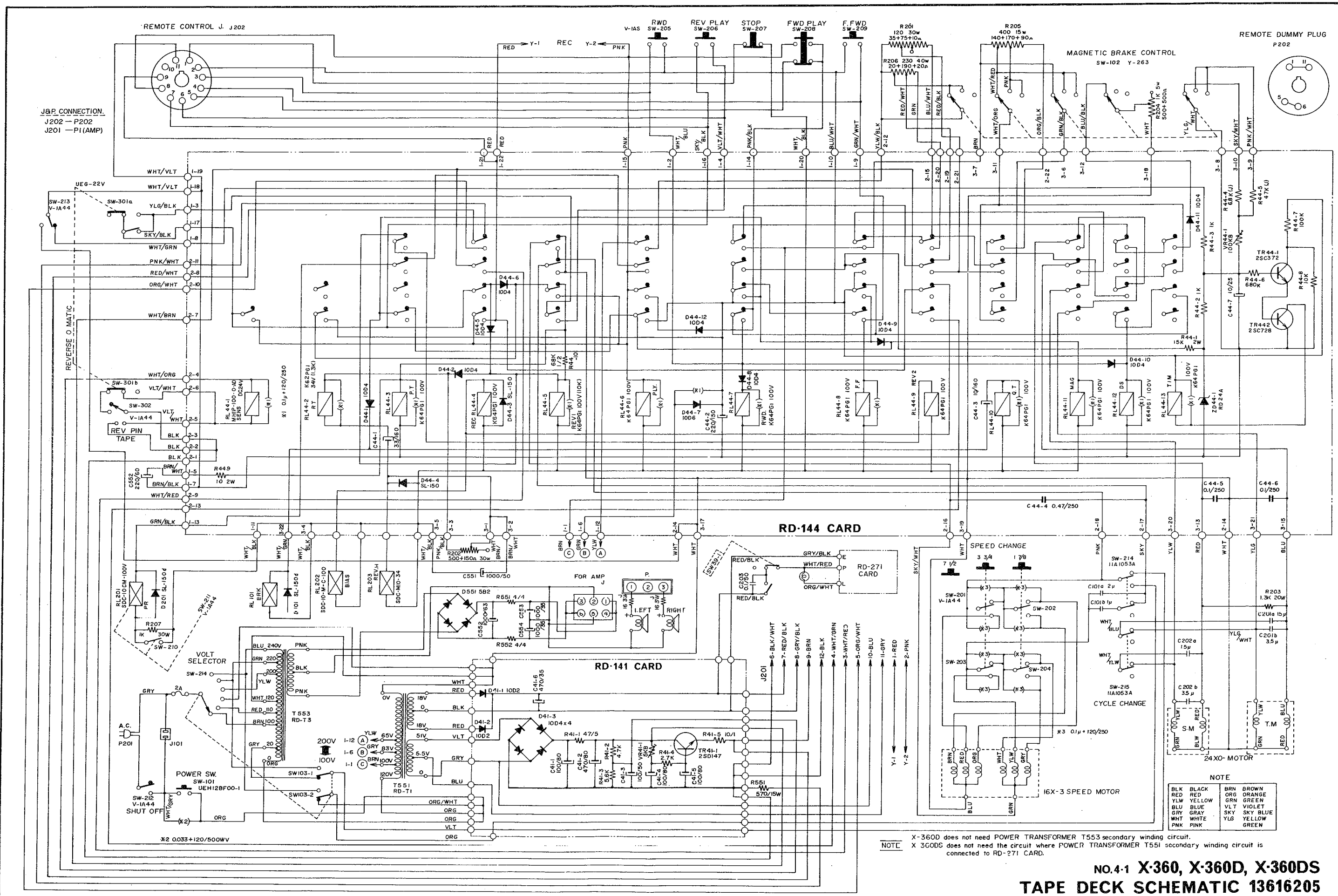

**NOTE**

BLK	BLACK	BRN	BROWN
RED	RED	ORG	ORANGE
YLG	YELLOW	GRN	GREEN
BLU	BLUE	VL T	VIOLET
GRY	GRAY	SKY	SKY BLUE
WHT	WHITE	YLG	YELLOW
PNK	PINK	GRN	GREEN

**no.4-1 X-360, X-360D, X-360DS  
TAPE DECK SCHEMATIC 13616205**



1-4 STEREO 3-2

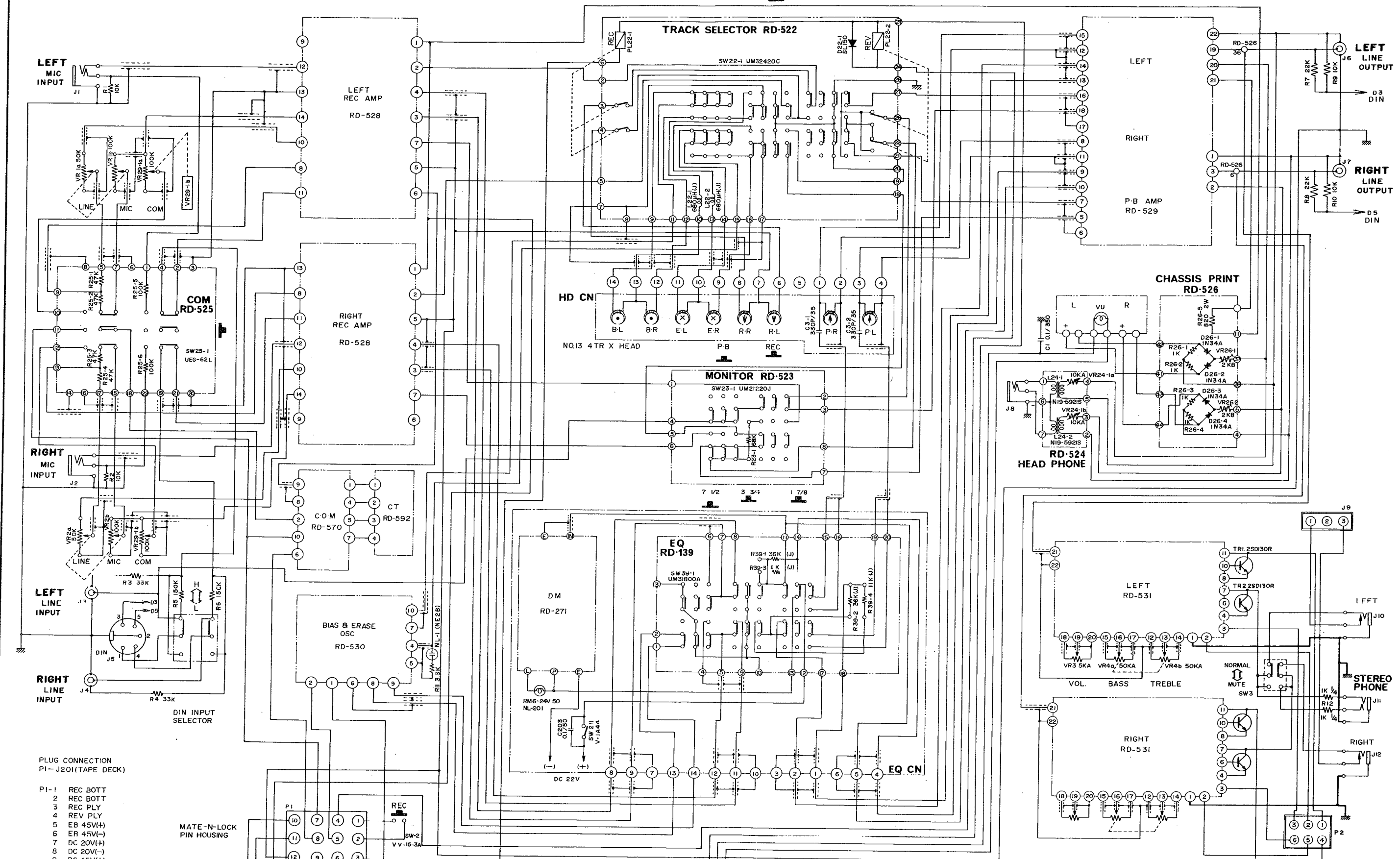

PLUG CONNECTION  
PI-J201(TAPE DECK)

- PI-1 REC BOTT
- 2 REC BOTT
- 3 REC PLY
- 4 REV PLY
- 5 EB 45V(+)
- 6 ER 45V(-)
- 7 DC 20V(+)
- 8 DC 20V(-)
- 9 DC 45V(+)
- 10 AC 5.5V
- 11 AC 5.5V
- 12 DC 45V(-)

MATE-N-LOCK  
PIN HOUSING

NOTE  
X-360 does not need HEAD PHONE PRINT CARD (RD-524) and its belonging circuit.  
X-360D does not need MAIN AMPLIFIER CARD (RD-531) and its belonging circuit.  
X-360DS does not need MAIN AMPLIFIER CARD (RD-531) and its belonging circuit.  
DM RD-271 CARD and its belonging circuit.  
COM RD-525, RD-570, CT RD-592 CARD and their belonging circuit.

NO.4-2 X-360, X-360D, X-360DS  
AMP. SCHEMATIC 13616224

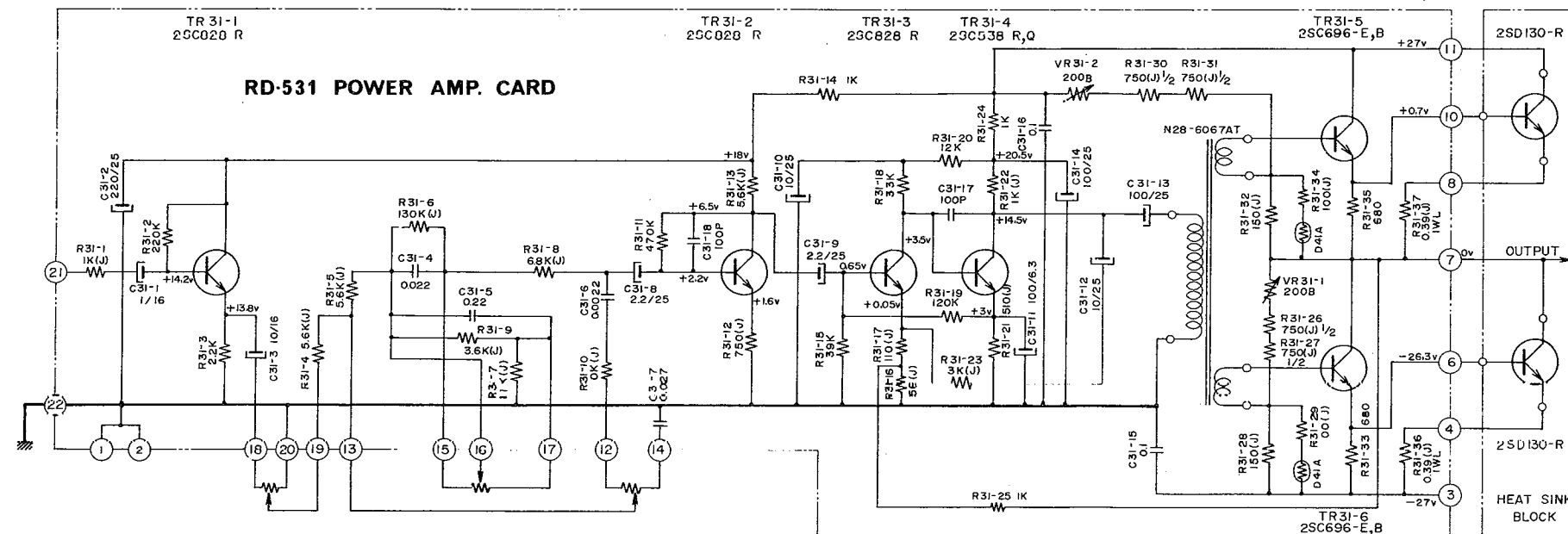
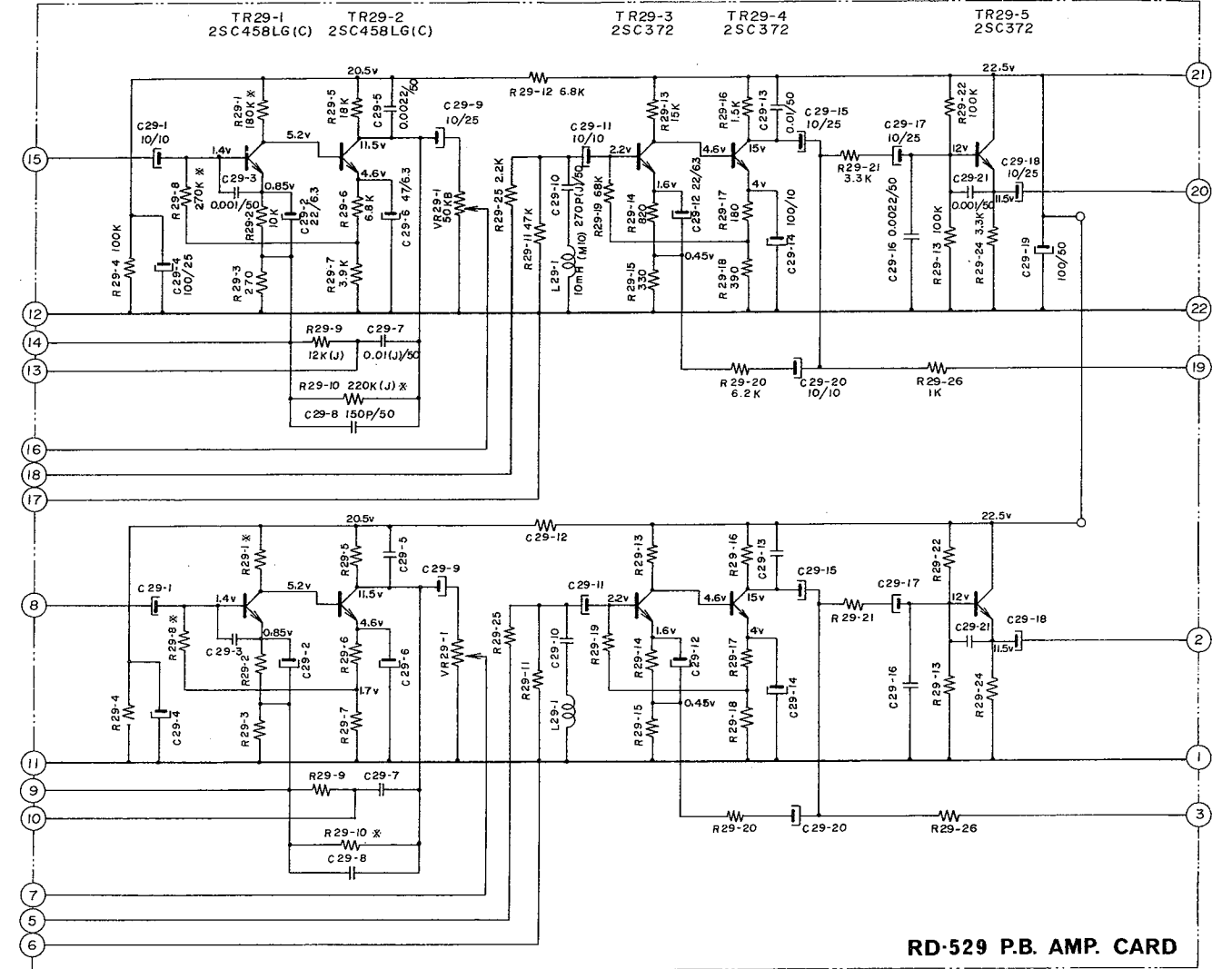
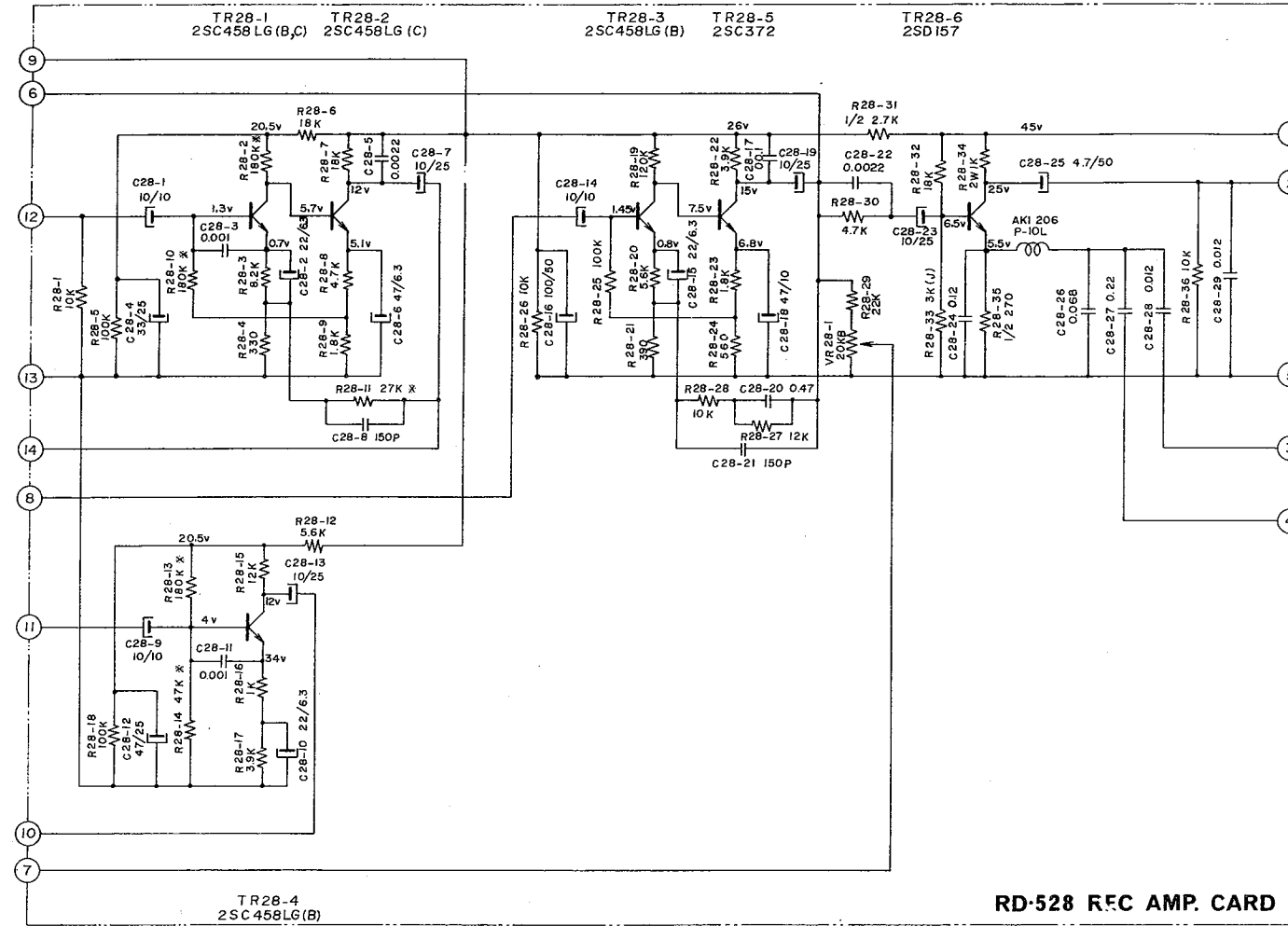

**NOTE**

RESISTOR  
\* ---- NOISE LESS

RD-531 POWER AMP. CARD is not needed in X-360D and X-360DS.

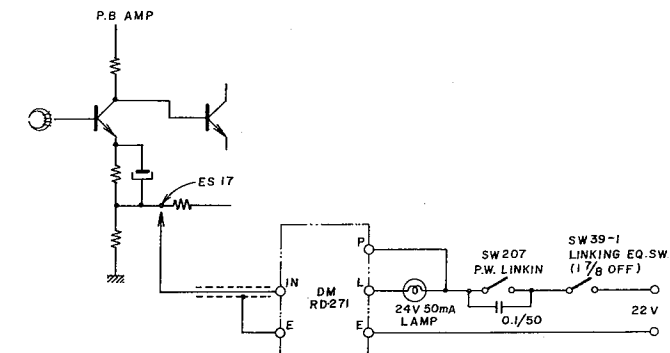
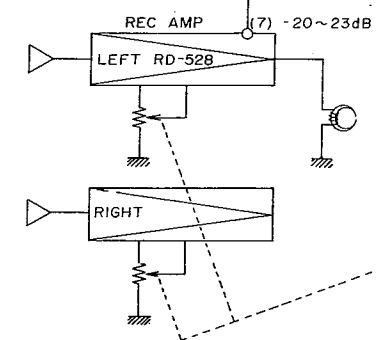
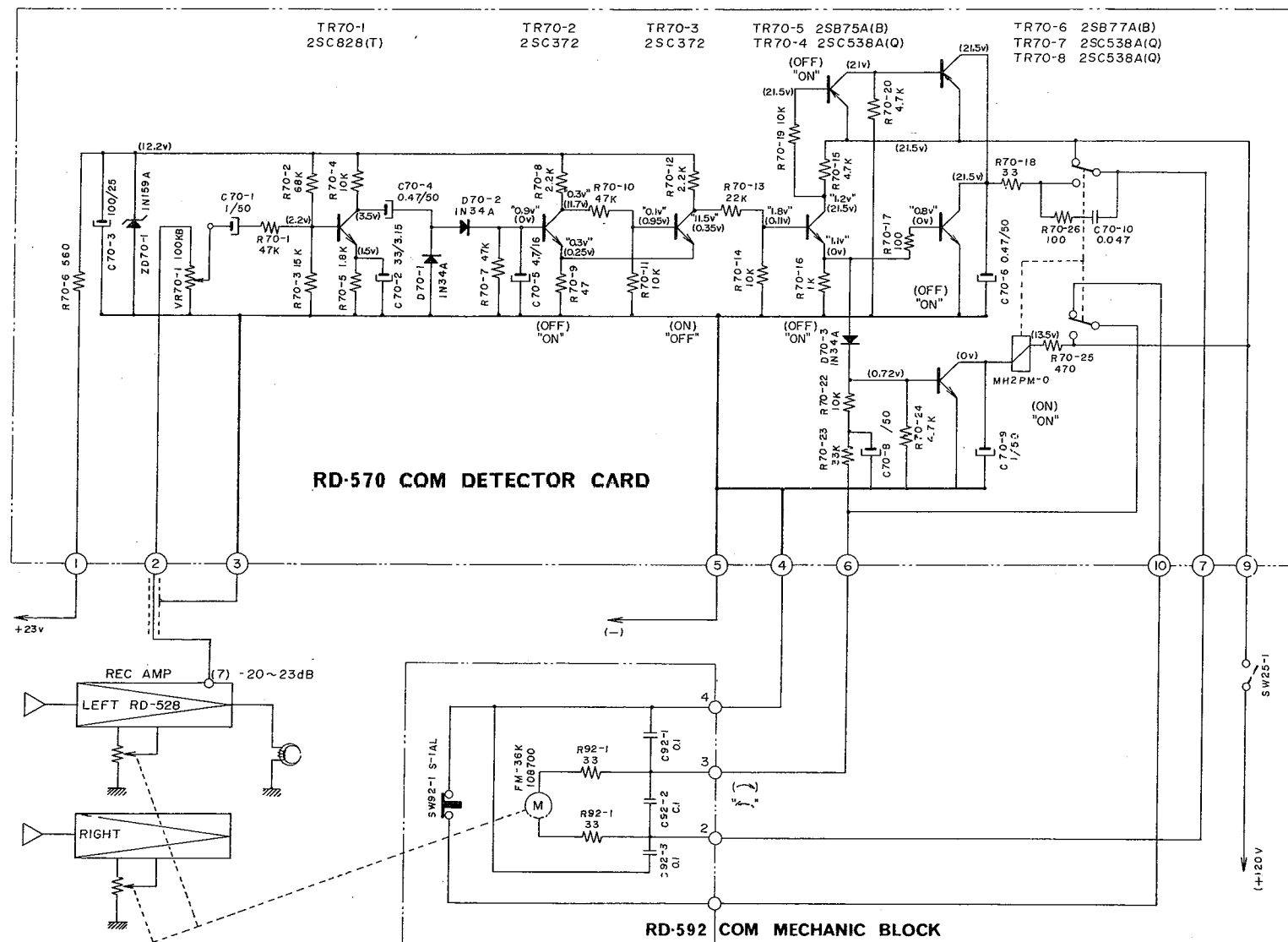
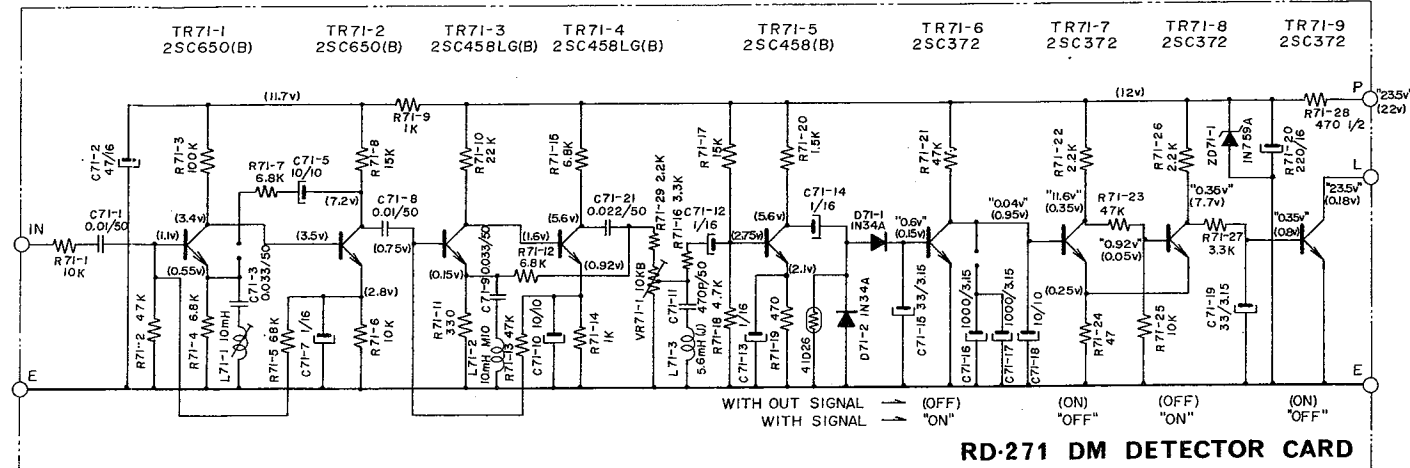
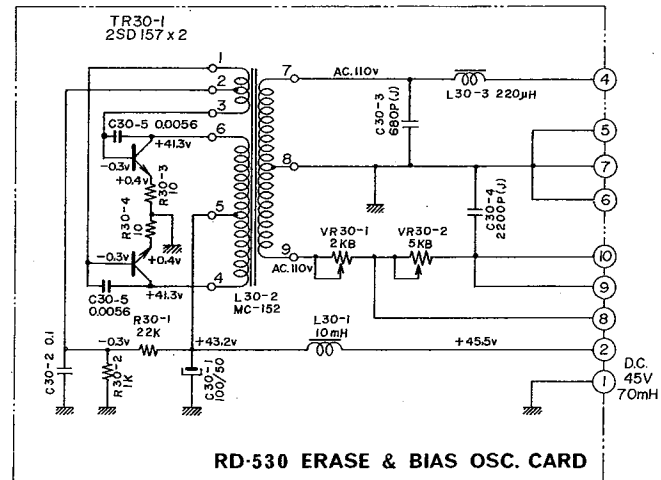

NOTE ( ) SHOWING LAMP IS "ON"  
" " SHOWING LAMP IS "OFF"

NOTE  
RD-570 C.O.M. DETECTOR CARD and RD-592 C.O.M. MECHANIC BLOCK is not needed in X-360DS.  
RD-271 DM DETECTOR CARD is not needed in X-360DS.

NO.4-4 X-360, X-360D, X-360DS  
AMP. CARD SCHEMATIC 13616124

NOTE ( ) SHOWING NON-INPUT SIGNAL CONDITION  
SHOWING AUTOMATIC Ovu SET  
WHILE MOTOR ROTATES (WHEN MORE THAN Ovu SIGNAL INPUT)

N. W.

REFERENCE FOR THE REPAIR II RD-144 System Control Board (Old Type)

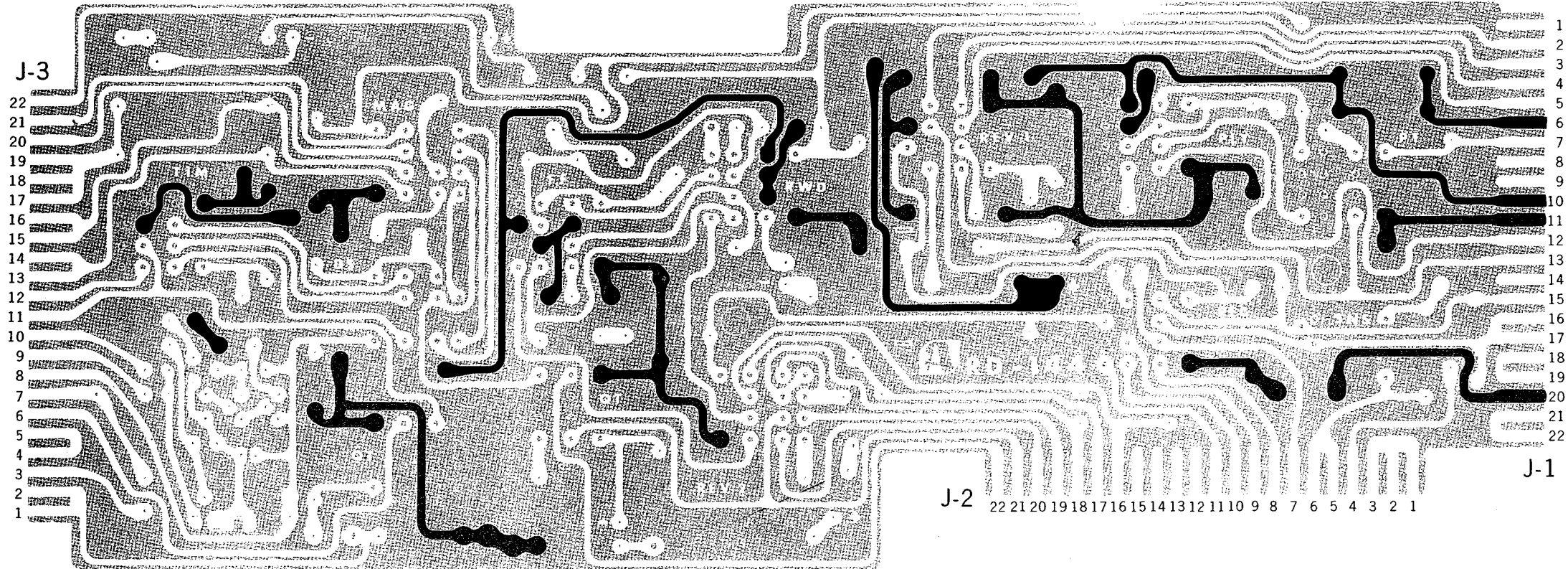

REFERENCE FOR THE REPAIR I RD-144 System Control Board (New Type)

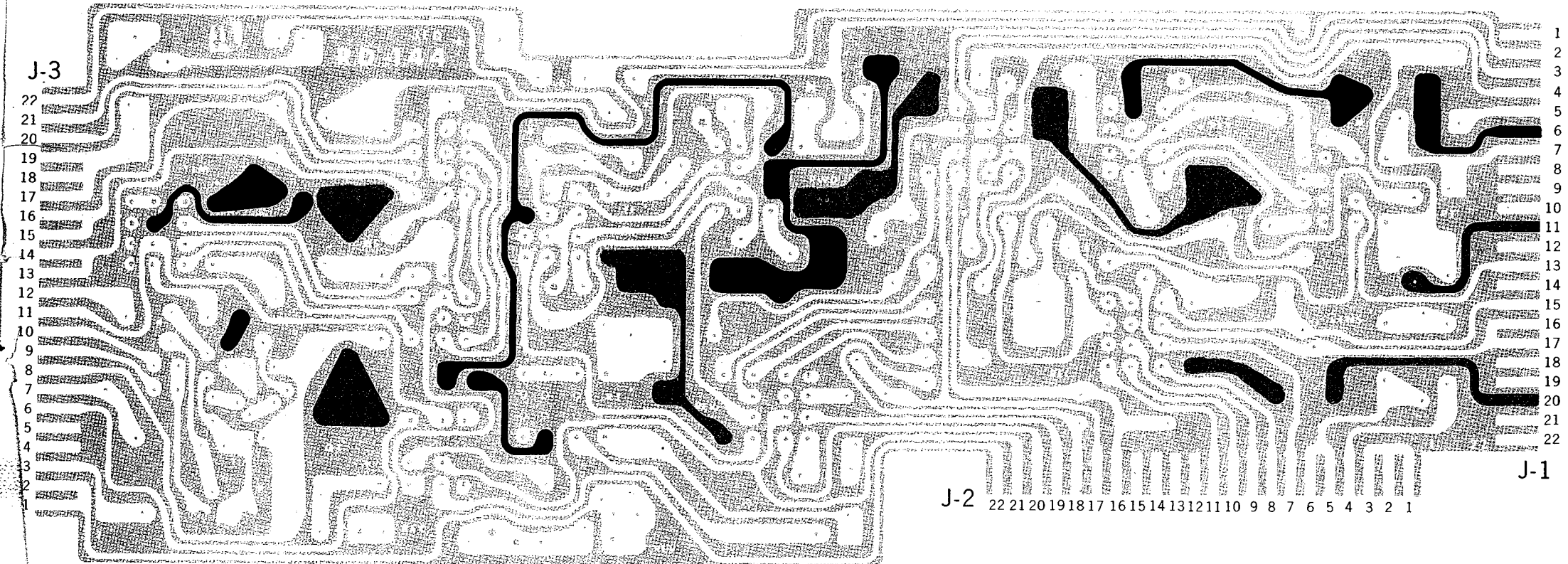

YELLOW...NEGATIVE. RED...POSITIVE(STOP CONDITION) BLACK POINT...CONNECTING POINT (CONNECTING BOTH SIDES OF THE BOARD)

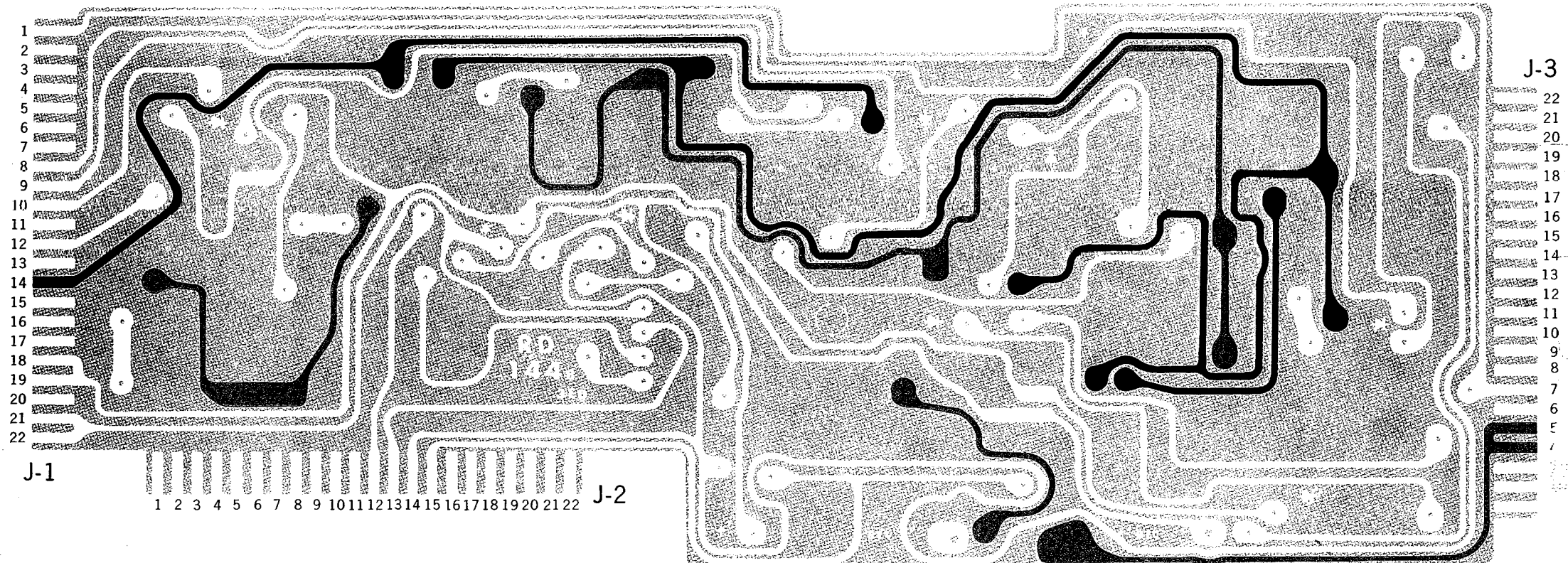
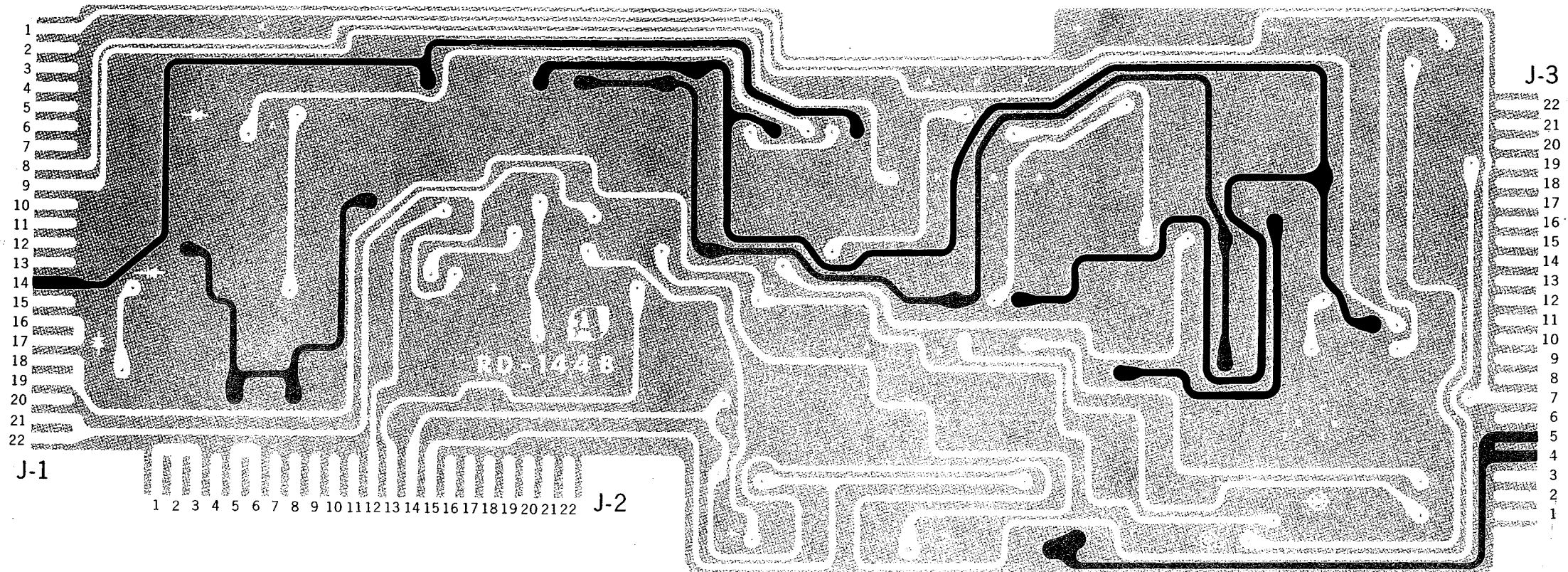

YELLOW...NEGATIVE.RED...POSITIVE(STOP CONDIITION) BLACK POINT...CONNECTING POINT (CONNECTING BOTH SIDES OF THE BOARD)

293

# PARTS LIST

**AKAI TAPE RECORDER**

**MODEL X-360**

ALSO APPLICABLE FOR MODEL X-360D

# REPLACEMENT PARTS TABLE

---

## X-360 PARTS LIST

	Page
HEAD BLOCK	RD-1100 ..... 2
CAPSTAN & PINCH WHEEL BLOCK	RD-1200 ..... 4
STABILIZER BLOCK	RD-1300 ..... 4
CYCLE CHANGE BLOCK	RD-1700 ..... 7
MECHANISM CHASSIS	RD-2000 ..... 7
REEL MOTOR & TABLE BLOCK	RD-1400 ..... 8
REVERSE MECHANISM BLOCK	RD-1600 ..... 8
MAIN MOTOR BLOCK	RD-1500 ..... 10
BRAKE BLOCK	RD-1800 ..... 10
RESISTOR BLOCK	RD-1900 ..... 10
RELAY BOARD BLOCK	RD-144 ..... 12
POWER SOURCE BLOCK	RD-2100 ..... 14
POWER SOURCE PRINTED BOARD	RD-141 ..... 16
OSCILLATOR BOARD	RD-530 ..... 17
DM DETECTOR BOARD	RD-271 ..... 18
PLAYBACK PRE-AMPLIFIER BOARD	RD-529 ..... 20
RECORDING AMPLIFIER BOARD	RD-528 ..... 22
MAIN AMPLIFIER BOARD	RD-531 ..... 24
MONITOR SWITCH BOARD	RD-523 ..... 26
TRACK SELECTOR BOARD	RD-522 ..... 27
C.O.M. DETECTOR BOARD	RD-570 ..... 28
C.O.M. SET SWITCH BLOCK	RD-525 ..... 30
C.O.M. MECHANIC BLOCK	RD-2200 ..... 31
SPARK QUENCHER & SWITCH BLOCK	RD-150B ..... 32
SPEED SELECTOR SWITCH BLOCK	RD-139B ..... 33
AMPLIFIER CHASSIS BLOCK	RD-2300 ..... 34
CASE & PANEL BLOCK	RD-2500 ..... 36
HEADPHONE CONNECTION BOARD (X-360D only)	RD-524 ..... 38
CHASSIS PRINTED BOARD	RD-526 ..... 39
MAIN AMPLIFIER SOCKET BORD	RD-532 ..... 39

**PARTS TABLE 1**

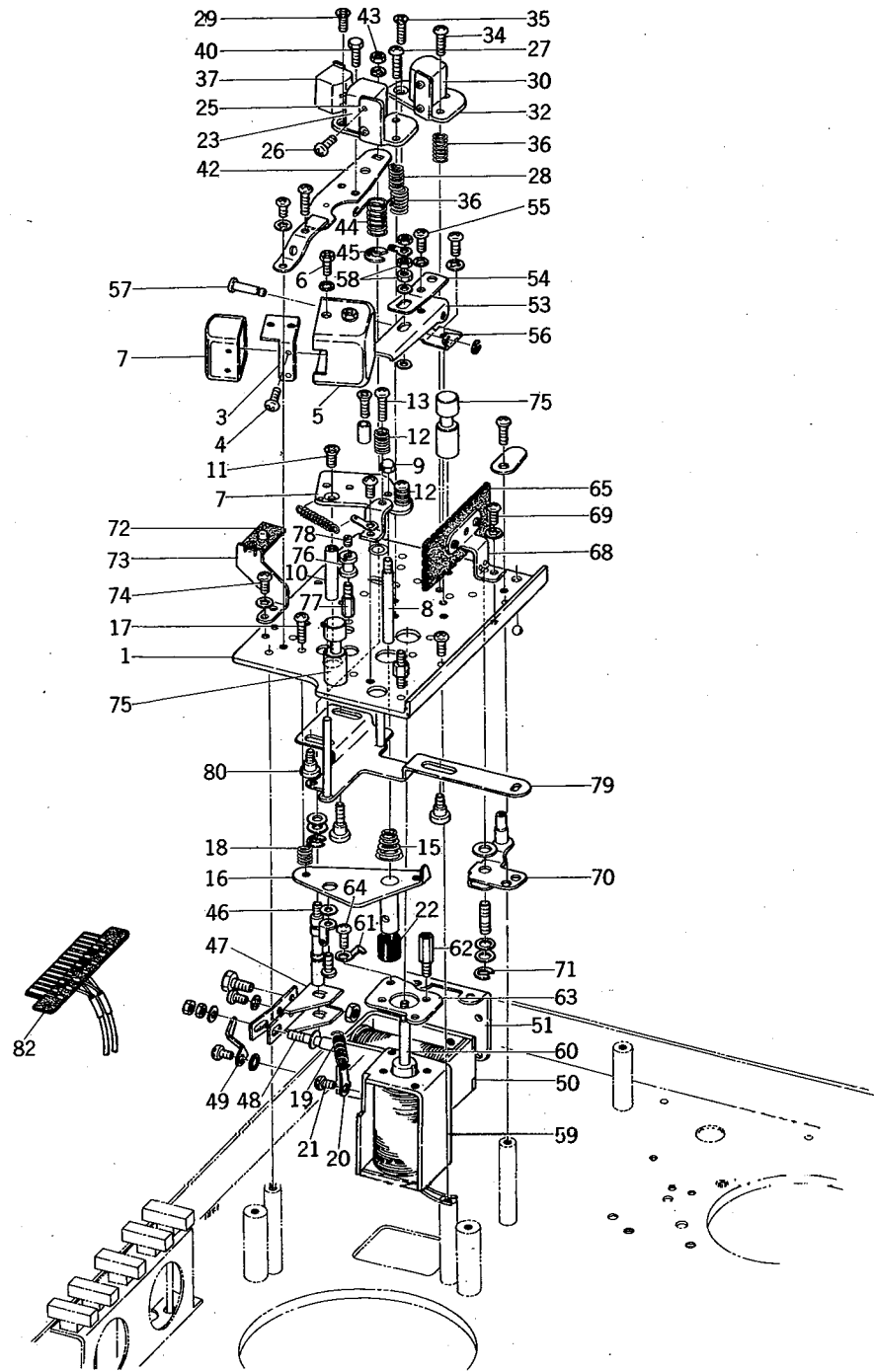

**HEAD BLOCK (RD-1100)**

Ref. No.	Parts No.	Nomenclature	Ref. No.	Parts No.	Nomenclature
0	RD-1100	Head Assembly Complete	6	RD-1106	Hexagon Head Screw (Bracket Mounting)
1	RD-1101	Chassis, Head Assembly	7	RD-1107	Plate, Shielded Case Mounting
2	RD-1102	Playback Head	8	RD-1108	Shaft, Playback Head Mounting
3	RD-1103	Bracket, P.B. Head Mounting	9	RD-1109	Cap Nut 3 mm, Shaft Mounting
4	RD-1104	Screw, pan head 2 x 3 mm (Head Mounting)	10	RD-1110	Guide prop, Playback Head
5	RD-1105	Shielded Case, Playback Head	11	RD-1111	Screw, flat head 3 x 6 mm



**PARTS TABLE 1**

Ref. No.	Parts No.	Nomenclature	Ref. No.	Parts No.	Nomenclature
12	RD-1112	Spring, Head Height Adjustment	45	RD-1145	"U" Ring
13	RD-1113	Screw, round head 3 x 10 mm	46	RD-1146	Prop, Bias Head Activating
14	RD-1114	Screw, round head 3 x 4 mm	47	RD-1147	Solenoid Link, Bias Head Activating
15	RD-1115	Spider Spring, Head up-down	48	RD-1148	Link, Solenoid Plunger
16	RD-1116	Plate, P.B. Head Angle Adjustment	49	RD-1149	Solenoid Stopper
17	RD-1117	Screw, round head 3 x 15 mm	50	RD-1150	Solenoid (SDCM10B-100) Bias Head Activating
18	RD-1118	Spring, P.B. Head Angle Adjustment	51	RD-1151	Bracket, Solenoid Mounting
19	RD-1119	Spring, P.B. Head Tension	52	RD-1152	Screw, binding head 3 x 5 mm
20	RD-1120	4 mm Lug Plate	53	RD-1153	Lever, Playback Head Activating
21	RD-1121	Screw, round head, Lug Plate Mounting 3 x 5 mm	54	RD-1154	Bar Spring
22	RD-1122	Dust Cover Cap	55	RD-1155	Screw, binding head 3 x 5 mm
23	RD-1123	Recording Head	56	RD-1156	Bracket, Lever Mounting
24	RD-1124	Spacer Metal, Recording Head Mounting	57	RD-1157	Prop, Lever Mounting
25	RD-1125	Bracket, Recording Head Mounting	58	RD-1158	Nut 3 mm
26	RD-1126	Screw, pan head 2 x 4 mm (Head Mounting)	59	RD-1159	Solenoid SDC-M-10B-34, Playback Head Activating
27	RD-1127	Screw, round head 3 x 12 mm (Bracket Mounting)	60	RD-1160	Link, Solenoid Plunger
28	RD-1128	Spring, Head Angle Adjustment	61	RD-1161	Solenoid Stopper
29	RD-1129	Screw, counter sunk head 3 x 12 mm (Bracket Mounting)	62	RD-1162	Hexagonal Prop, Solenoid Mounting
30	RD-1130	Erase Head	63	RD-1163	Plate, Solenoid Mounting
31	RD-1131	Spacer Metal, Erase Head Mounting	64	RD-1164	Screw, binding head 3 x 5 mm
32	RD-1132	Bracket, Erase Head Mounting	65	RD-1165	Printed Board, RD-43 (Head Connection)
33	RD-1133	Screw, pan head 2 x 4 mm (Head Mounting)	66	RD-1166	Capacitor, Mica 330P/50V
34	RD-1134	Screw, round head 3 x 12 mm (Bracket Mounting)	67	RD-1167	Capacitor, C3-2 330P/35V
35	RD-1135	Screw, counter sunk head 3 x 12 mm (Bracket Mounting)	68	RD-1168	Bracket, Printed Board Mounting
36	RD-1136	Spring, Head Angle Adjustment	69	RD-1169	Screw, binding head 3 x 5 mm with washer
37	RD-1137	Bias Head	70	RD-1170	Tape Cleaner Lever
38	RD-1138	Bracket, Bias Head Mounting	71	RD-1171	"U" Ring, Cleaner Lever Mounting
39	RD-1139	Screw, pan head 2 x 4 mm (Head Mounting)	72	RD-1172	Printed Board (RD-53, DM Lamp Mounting)
40	RD-1140	Screw, hexagonal head 3 x 4 mm (Bracket Mounting)	73	RD-1173	Bracket, Printed Board Mounting
41	RD-1141	Washer 7.8 x 0.5 mm	74	RD-1174	Screw, binding head 3 x 5 mm with washer
42	RD-1142	Lever, Bias Head Activating	75	RD-1175	Tape Guide A
43	RD-1143	Nut 3 mm (lever Mounting)	76	RD-1176	Tape Guide B
44	RD-1144	Spring, Bias Head hold-down	77	RD-1177	Hexagonal Prop, Tape Guide Mounting
			78	RD-1178	Set Screw 3 x 5 mm
			79	RD-1179	Tape Shifter Lever
			80	RD-1180	Guide Screw, flat head 3 x 5 mm (Tape Shifter Mounting)
			81	RD-1181	Screw, round head 3 x 12 mm
			82	RD-1182	Printed Plug, 14 P

PARTS TABLE 2

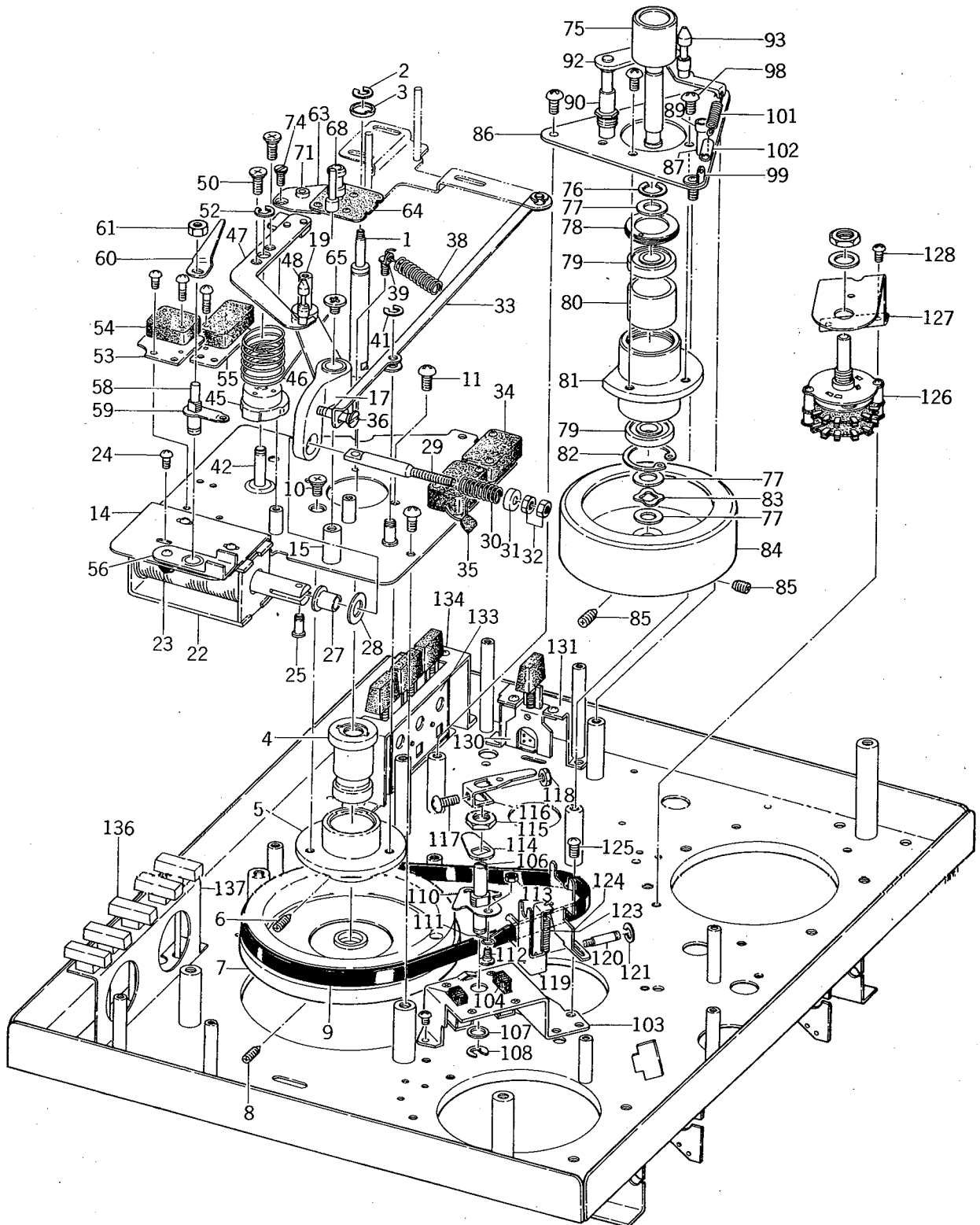

**PARTS TABLE 2**

**CAPSTAN & PINCH ROLLER BLOCK (RD-1200)**

Ref. No.	Parts No.	Nomenclature	Ref. No.	Parts No.	Nomenclature
			39	RD-1239	Bracket, Spring Holder
0	RD-1200	Capstan Flywheel Assembly Complete	40	RD-1240	Screw, pan head 4 x 6 mm
1	RD-1201	Capstan Shaft	41	RD-1241	"U" Ring
2	RD-1202	"E" Ring, Capstan Shaft	42	RD-1242	Shaft, Tension Aem
3	RD-1203	Nylon Washer, Capstan Shaft (Claw washer)	43	RD-1243	Nut 4 mm
4	RD-1204	Bearing, Capstan	44	RD-1244	Washer
5	RD-1205	Bearing Case, Capstan	45	RD-1245	Cam, Shut-off Switch Activating
6	RD-1206	Set Screw 4 x 6 mm, Bearing Mounting	46	RD-1246	Spring, Tension Arm
7	RD-1207	Flywheel, Capstan	47	RD-1247	Tension Arm
8	RD-1208	Set Screw, 5 x 6 mm, Flywheel Mounting	48	RD-1248	Tape Guide C, Tension Arm
9	RD-1209	Capstan Drive Belt (diameter 120 mm)	49	RD-1249	Screw, counter sunk head 3 x 6 mm
10	RD-1210	Screw, counter sunk head 4 x 8 mm (Flywheel Mounting)	50	RD-1250	Screw, counter sunk head 2.3 x 12 mm
11	RD-1211	Screw, pan head 4 x 8 mm, Flywheel Mounting	51	RD-1251	Nut 2.3 mm
12	RD-1212	Pinch Roller (for 7.5 ips)	52	RD-1252	"U" Ring
13	RD-1213	Pinch Roller Cap	53	RD-1253	Plate A, Micro Switch Mounting
14	RD-1214	Chassis, Flywheel Mounting	54	RD-1254	Micro Switch V-1A44
15	RD-1215	Shaft, Pinch Roller Lever	55	RD-1255	Plate B, Micro Switch Mounting
16	RD-1216	Washer 13 x 0.2 mm, Pinch Roller Lever	56	RD-1256	Plate, Tension Arm Stop Lever Mounting
17	RD-1217	Lever, Pinch Roller Activating	57	RD-1257	Screw, pan head 3 x 5 mm
18	RD-1218	Screw, flat head 4 x 6 mm	58	RD-1258	Shaft, Stop Lever
19	RD-1219	Shaft, Pinch Roller Mounting	59	RD-1259	Leaf Spring, Stop Lever
20	RD-1220	Washer 10.3 x 0.8 mm, Pinch Roller Shaft	60	RD-1260	Stop Lever, Tension Arm
21	RD-1221	Nut 4 mm	61	RD-1261	Nut 6 mm (special)
22	RD-1222	Solenoid SDC-10CM-100V, Pinch Roller Activating	62	RD-1262	"E" Ring 4 mm
23	RD-1223	Diode SL-150	63	RD-1263	Plate, Printed Board Mounting
24	RD-1224	Screw, pan head 3 x 5 mm, Solenoid Mounting	64	RD-1264	Printed Board, Reverse Pin
25	RD-1225	Connection Pin 3 x 15.5 mm	65	RD-1265	Reverse Pin
26	RD-1226	"E" Ring, 1.9 mm (for Connection Pin)	66	RD-1266	Nut 2.3 mm
27	RD-1227	Metal Sleeve	67	RD-1267	Prop, Reverse Tape Guide
28	RD-1228	Washer 16 x 1 mm	68	RD-1268	Reverse, Tape Guide
29	RD-1229	Shaft, Solenoid Link	69	RD-1269	Set Screw, 4 x 5 mm
30	RD-1230	Spring, Pinch Roller Tension	70	RD-1270	Nut 3 mm
31	RD-1231	Spring Stopper	71	RD-1271	Cushion, Rubber Sleeve
32	RD-1232	Cap, Nut 4mm	72	RD-1272	Screw, round head 3 x 4 mm
33	RD-1233	Lever, Tape Shifter Activating	73	RD-1273	Screw, pan head 3 x 8 mm
34	RD-1234	Micro Switch V-1A44	74	RD-1274	Screw, counter sunk head 3 x 6 mm
35	RD-1235	Capacitor Mylar 0.1μF 50V	<b>STABILIZER BLOCK (RD-1300)</b>		
36	RD-1236	Screw 4 x 20 mm, Lever Mounting	RD-1300	Stabilizer Assembly Complete	
37	RD-1237	Nut 4 mm	75	RD-1301	Stabilizer Shaft
38	RD-1238	Spring, Tape Shifter Lever Tension	76	RD-1302	"E" Ring 7 mm
			77	RD-1303	SVS Washer 15.8 x 0.25 mm
			78	RD-1304	Stopper Ring (Bearing Mount)
			79	RD-1305	Bearing 608VVC2EL
			80	RD-1306	Spacer Collar

PARTS TABLE 2

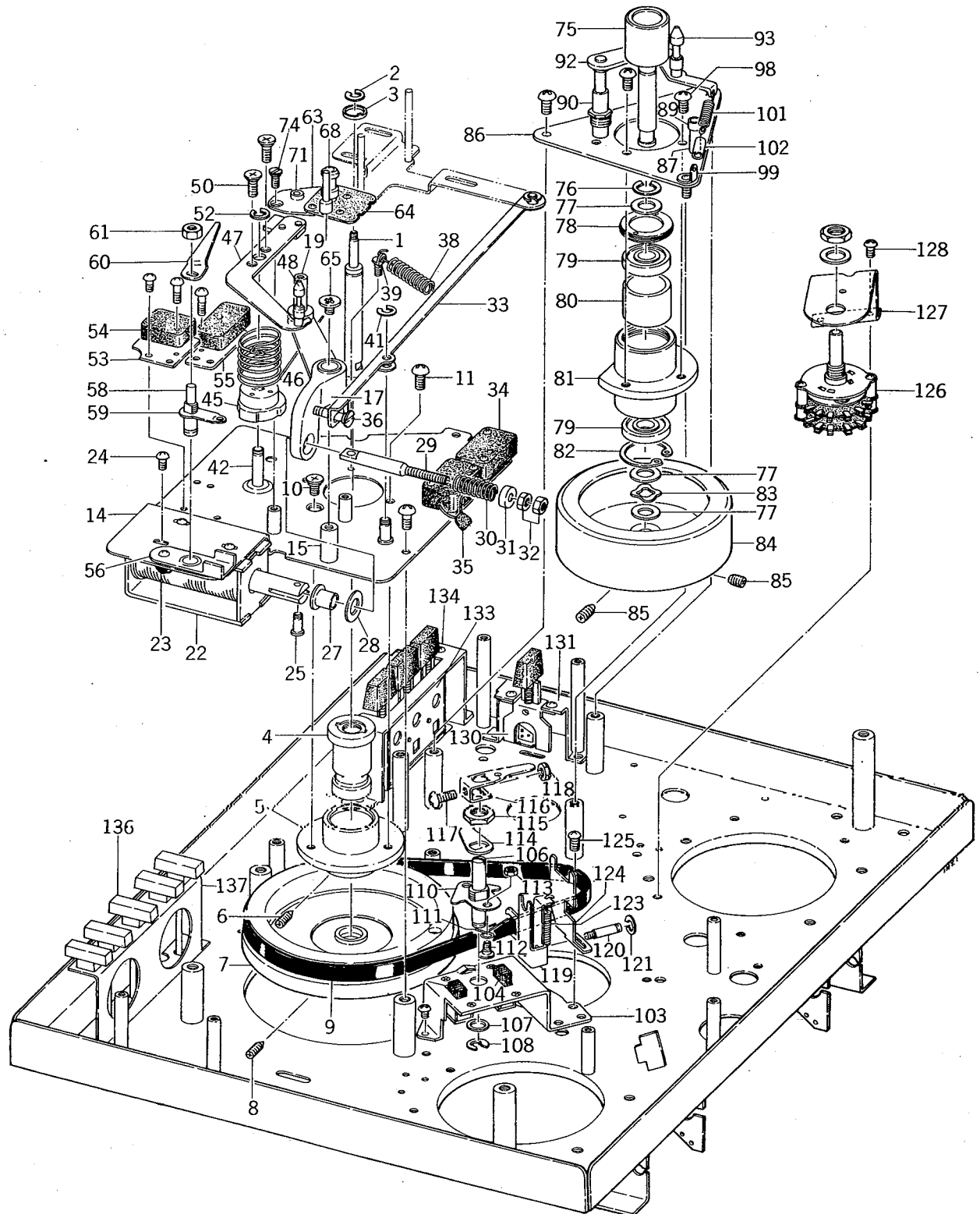

**PARTS TABLE 2**

Ref. No.	Parts No.	Nomenclature
81	RD-1307	Bearing Case
82	RD-1308	"C" Ring 22 mm (Bearing Hold)
83	RD-1309	Spring Washer
84	RD-1310	Stabilizer Wheel
85	RD-1311	Set Screw 5 x 5 mm
86	RD-1312	Plate, Stabilizer Mounting
87	RD-1313	Prop, Stopper for Tension Arm
88	RD-1314	Screw, binding head
89	RD-1315	Rubber Cushion
90	RD-1316	Bearing, Tension Arm
91	RD-1317	Nut 9 mm
92	RD-1318	Tension Arm
93	RD-1319	Tape Guide C, Tension Arm
94	RD-1320	Metal Washer 8 x 0.2 mm
95	RD-1321	Screw, counter sunk head 3 x 5 mm
96	RD-1322	Metal Washer, 7.8 x 0.5 mm
97	RD-1323	Nut 3 mm
98	RD-1324	Screw, pan head 4 x 8 mm
99	RD-1325	Lug Plate 4 mm
100	RD-1326	Screw, pan head 4 x 8 mm
101	RD-1327	Spring, Tension Arm
102	RD-1328	Nylon Tube 5 x 18 mm (for Tension Spring)

**CYCLE CHANGE BLOCK (RD-1700)**

	RD-1700	Cycle Change Block Assembly Complete
103	RD-1701	Bracket, Cycle Change Switch Mounting
104	RD-1702	Slide Switch DPDT ESD- 270DU 11A-1053A
105	RD-1703	Screw, counter sunk head No. 4-40 x 6 (inch size)
106	RD-1704	Shaft, Cycle Change Switch
107	RD-1705	Nylon Washer 10 x 1 mm
108	RD-1706	"U" Ring 4 mm
109	RD-1707	Steel Ball 4 mm
110	RD-1708	Plate, Cycle Change Switch
111	RD-1709	Spring, Plate Activating
112	RD-1710	Screw, flat head 3 x 6 mm (Spring Mount)
113	RD-1711	Nut 3 mm
114	RD-1712	Bar Spring (Steel Ball Stopper)
115	RD-1713	Nut
116	RD-1714	Shifter Lever, Cycle Change
117	RD-1715	Screw, pan head 4 x 8 mm
118	RD-1716	Nut 4 mm
119	RD-1717	Cycle Change Lever

Ref. No.	Parts No.	Nomenclature
120	RD-1718	Shaft, Cycle Change Lever
121	RD-1719	"C" Ring
122	RD-1720	Nut 3 mm, Shaft Mounting
123	RD-1721	Spring, Cycle Change Lever
124	RD-1722	Stopper Metal (Cycle Change Lever)
125	RD-1723	Screw, binding head 3 x 5 mm

**MECHANISM CHASSIS (RD-2000)**

126	RD-2001	Magnetic Brake Control Switch (Y263)
127	RD-2002	Bracket, Brake Control Switch Mounting
128	RD-2003	Screw, binding head 3 x 5 mm
129	RD-2004	Silicon Diode 10D4
130	RD-2005	Power Switch Complete UEH12BF00-1
131	RD-2006	Bracket, Power Switch Mounting
132	RD-2007	Spark Quencher (0.033 $\mu$ F + 120 $\Omega$ 500V)
133	RD-2008	Speed Selector Switch Assembly Complete (RD-139B)
134	RD-2009	Bracket, Speed Selector Switch Mounting
135	RD-2010	Screw, pan head 3 x 5 mm
136	RD-2018	Knob, Function Switch
137	RD-2019	Bracket, Knob Mounting

PARTS TABLE 3

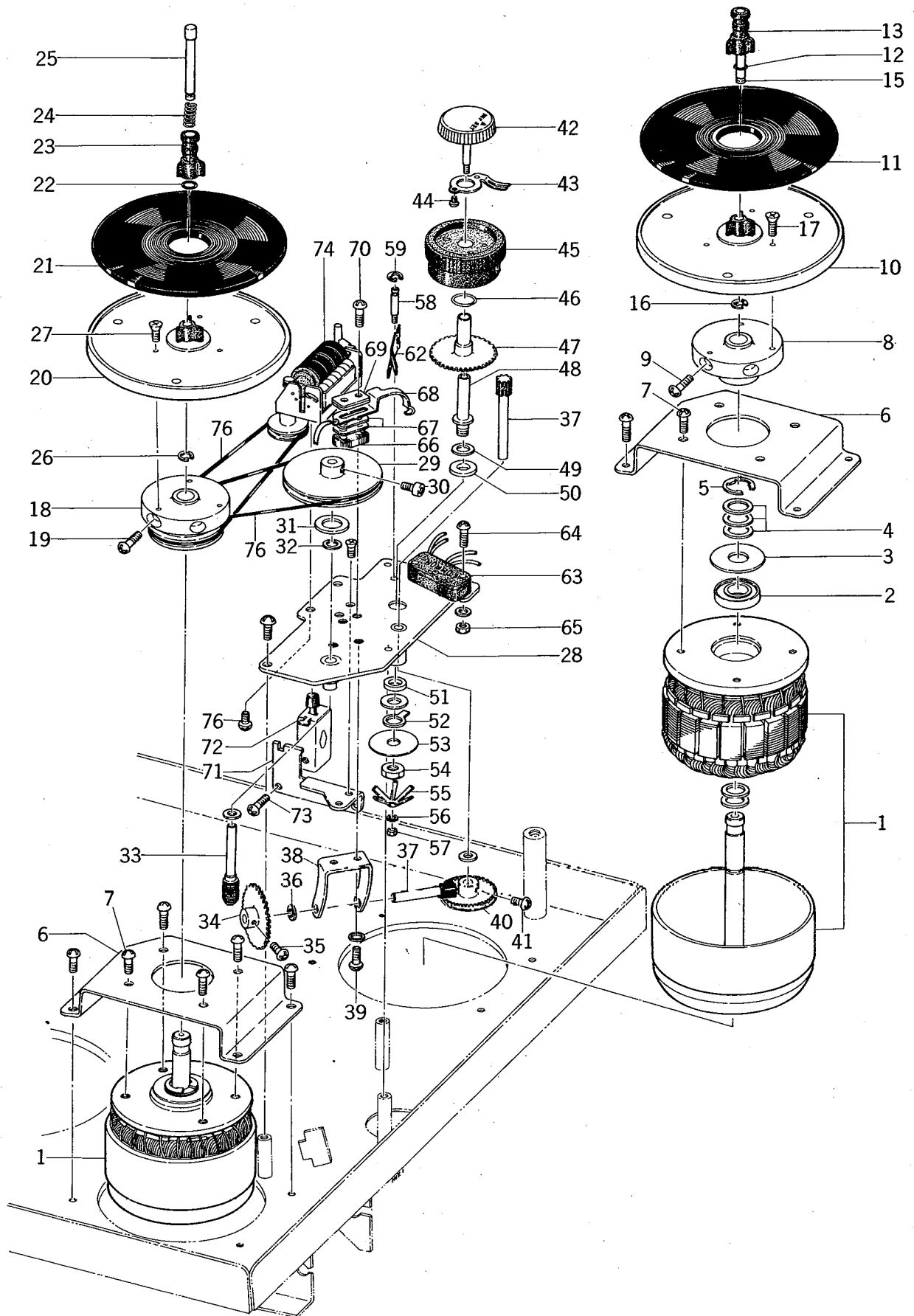

**PARTS TABLE 3**

**REEL MOTOR & REEL TABLE BLOCK (RD-1400)**

Ref. No.	Parts No.	Nomenclature
	RD-1400	Reel Motor Assembly Complete (24XO)
1	RD-1401	Reel Motor
2	RD-1402	Bearing 608VVC2EL
3	RD-1403	Nylon Washer 24 x 2 mm
4	RD-1404	Bronze Washer 13 x 0.1 mm
5	RD-1405	"E" Ring 7 mm (Rotor Shaft Hold)
6	RD-1406	Plate, Motor Mounting
7	RD-1407	Screw, pan head 4 x 6 mm
	RD-1408	Supply Reel Table Complete
8	RD-1409	Pulley, Supply Reel
9	RD-1410	Screw, pan head 4 x 8 mm
10	RD-1411	Reel Table
11	RD-1412	Rubber Plate, Reel Table
12	RD-1413	Rubber Ring 6 mm
13	RD-1414	Reel Retainer
14	RD-1415	Spring, Reel Retainer Shaft
15	RD-1416	Shaft, Reel Retainer
16	RD-1417	"E" Ring 1.9 mm
17	RD-1418	Screw, counter sunk head 3 x 10 mm
	RD-1419	Take-up Reel Complete
18	RD-1420	Pulley, Take-up Reel
19	RD-1421	Screw, pan head 4 x 8 mm (Pulley Mounting)
20	RD-1422	Reel Table
21	RD-1423	Rubber Plate, Reel Table
22	RD-1424	Rubber Ring 6 mm
23	RD-1425	Reel Retainer
24	RD-1426	Spring, Reel Retainer Shaft
25	RD-1427	Shaft, Reel Retainer
26	RD-1428	"E" Ring 1.9 mm
27	RD-1429	Screw, counter sunk head 3 x 10 mm

**REVERSE MECHANISM BLOCK (RD-1600)**

	RD-1600	Reverse Mechanism Assembly Complete
28	RD-1601	Chassis, Reverse Mechanism
29	RD-1602	Pulley (Belt Driven)
30	RD-1603	Screw, Cylinder Head 3 x 5 mm (Pulley Mounting)
31	RD-1604	Felt Washer 13 x 1 mm
32	RD-1605	Nylon Washer 7 x 0.25 mm
33	RD-1606	Worm Gear with Shaft
34	RD-1607	Spur Gear
35	RD-1608	Screw, round head 3 x 4 mm
36	RD-1609	Nylon Washer 7 x 0.025 mm
37	RD-1610	Pinion Gear with Shaft

Ref. No.	Parts No.	Nomenclature
38	RD-1611	Bracket, Gear Mounting
39	RD-1612	Screw, round head 3 x 4 mm
40	RD-1613	Link Gear
41	RD-1614	Screw, round head 3 x 4 mm
42	RD-1615	Reverse Set Dial
43	RD-1616	Contact Pin (Reverse)
44	RD-1617	Screw, binding head 2.3 x 3 mm
45	RD-1618	Tape Count Meter Dial
46	RD-1619	Metal Ring (for Tape Count Meter)
47	RD-1620	Spur Gear
48	RD-1621	Dial Shaft
49	RD-1622	Metal Washer 13 x 0.3 mm
50	RD-1623	Insulator (Nylon Bush)
51	RD-1624	Nylon Washer 10.3 x 0.5 mm
52	RD-1625	Lug Terminal
53	RD-1626	Metal Washer 22 x 0.5 mm
54	RD-1727	Nut 6 mm
55	RD-1628	Clutch Spring
56	RD-1629	Toothed Lock Washer 3 mm
57	RD-1630	Nut 2.3 mm
58	RD-1631	Prop, (Actuator Mounting)
59	RD-1632	"E" Ring 1.9 mm
60	RD-1633	Toothed Lock Washer 3 mm
61	RD-1634	Nut 2.3 mm
62	RD-1635	Actuator (Micro Switch)
63	RD-1636	Micro Switch V-1A44
64	RD-1637	Screw, round head 3 x 15 mm
65	RD-1638	Nut 3 mm
66	RD-1639	Insulator (Contact-maker)
67	RD-1640	Spacer, (Contact-maker)
68	RD-1641	Contact-maker (metal)
69	RD-1642	Metal Plate
70	RD-1643	Screw, round head 3 x 15 mm
71	RD-1644	Bracket, Reverse-o-matic Set Switch Mounting
72	RD-1645	Reverse-O-matic Set Switch (UEG-22V)
73	RD-1646	Screw, binding head 3 x 5 mm
74	RD-1747	Tape Counter Complete
75	RD-1648	Screw, binding head 3 x 5 mm
76	RD-1649	Counter Belt (75 mm)

PARTS TABLE 4

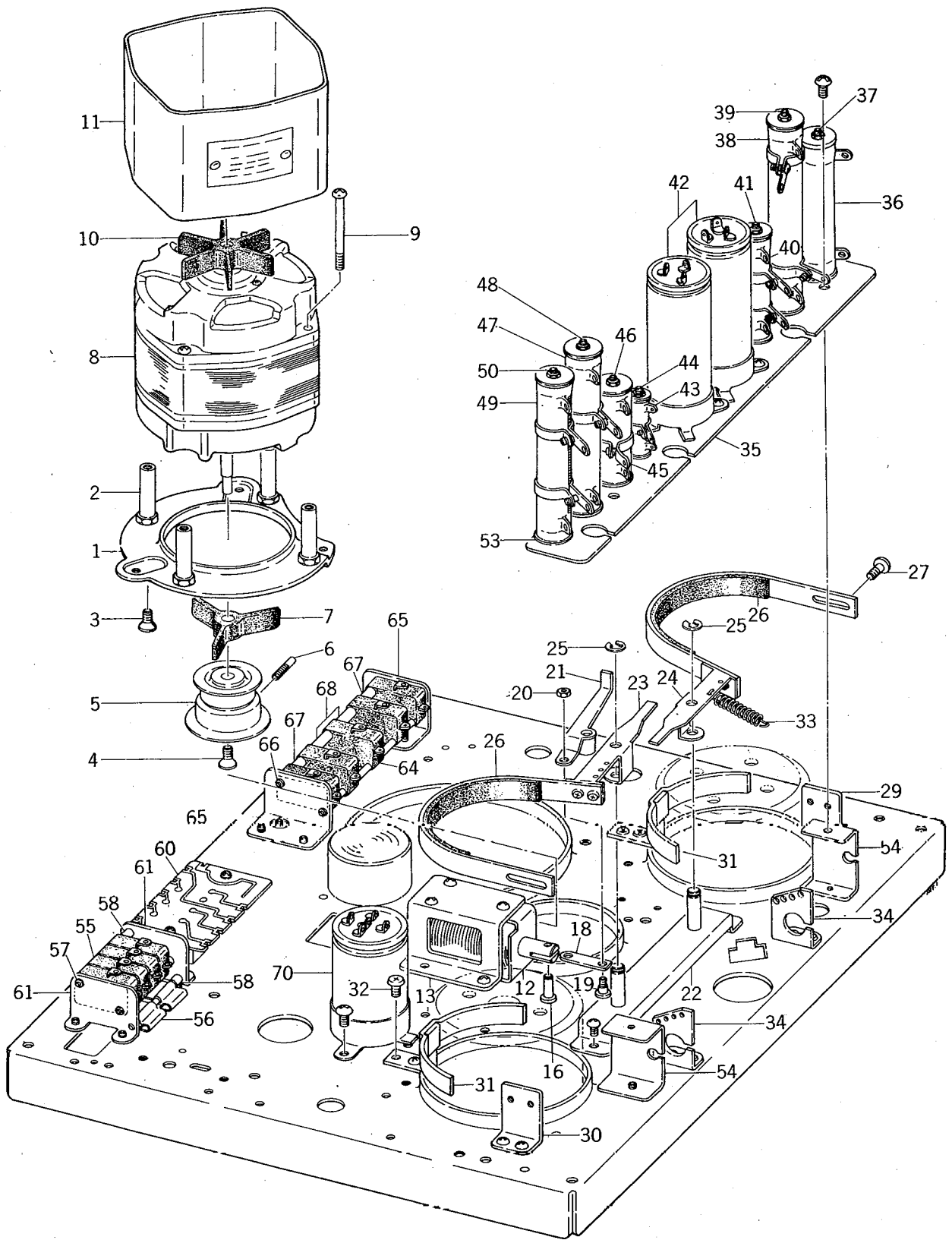



**PARTS TABLE 4**

**MAIN MOTOR BLOCK (RD-1500)**

Ref. No.	Parts No.	Nomenclature
	RD-1500	Main Motor Assembly Complete (16X)
1	RD-1501	Plate, Motor Mounting
2	RD-1502	Prop, Motor Mounting
3	RD-1503	Screw, counter sunk head 4 x 10 mm
4	RD-1504	Screw, oval counter sunk head 3 x 15 mm
5	RD-1505	Motor Pulley
6	RD-1506	Set Screw 3 x 7.5 mm (Motor Pulley Mounting)
7	RD-1507	Motor Fan (Rubber)
8	RD-1508	Main Motor
9	RD-1509	Screw, pan head 4 x 50 mm
10	RD-1510	Motor Fan (Rubber)
11	RD-1511	Shield Case

**BRAKE BLOCK (RD-1800)**

12	RD-1801	Solenoid SDCM10-C
13	RD-1802	Bracket, Solenoid Mounting
14	RD-1803	Screw, binding head 3 x 5 mm
15	RD-1804	Diode SL-150
16	RD-1805	Connection Pin 3 x 15.5 mm
17	RD-1806	"E" Ring 1.9 mm
18	RD-1807	Solenoid Ring
19	RD-1808	Screw, flat head 3 x mm
20	RD-1809	Nut 3 mm
21	RD-1810	Bracket Lever A
22	RD-1811	Bracket, Brake Lever Mounting
23	RD-1812	Braker Lever B
24	RD-1813	Braker Lever C
25	RD-1814	"C" Ring 2.85 mm
26	RD-1815	Brake Band with Felt
27	RD-1816	Screw, binding head 3 x 5 mm
28	RD-1817	Spring Washer 3 mm
29	RD-1818	Bracket A, Brake Band Mounting
30	RD-1819	Bracket B, Brake Band Mounting
31	RD-1820	Bracket, Brake Band Guide
32	RD-1821	Screw
33	RD-1822	Brake Tension Spring
34	RD-1823	Bracket, Brake Spring Mounting

**RESISTOR BLOCK (RD-1900)**

	RD-1900	Resistor Block Assembly Complete
35	RD-1901	Plate, Resistor and Capacitor Mounting
36	RD-1902	Resistor, 1K $\Omega$ (J) 30H
37	RD-1903	Screw, round head 3 x 85 mm
38	RD-1904	Resistor, 230 $\Omega$ (K) 40H
39	RD-1905	Screw, round head 4 x 100 mm
40	RD-1906	Resistor, 400 $\Omega$ (K) 15H

Ref. No.	Parts No.	Nomenclature
41	RD-1907	Screw, round head 3 x 60 mm
42	RD-1908	Metallized Paper Capacitor MP 35 $\mu$ + 15 $\mu$ 250VAC (Lug Tublar Type)
43	RD-1909	Resistor, 1K $\Omega$ (K) 5H
44	RD-1910	Screw, round head 3 x 50 mm
45	RD-1911	Resistor, 1.7K $\Omega$ (K) 20H
46	RD-1912	Screw, round head 3 x 65 mm
47	RD-1913	Resistor, 650 $\Omega$ (K) 30H
48	RD-1914	Screw, round head 3 x 85 mm
49	RD-1915	Resistor, 120 $\Omega$ (K) 30H
50	RD-1916	Screw, round head 3 x 85 mm
51	RD-1917	Nut 3 mm
52	RD-1918	Nut 4 mm
53	RD-1919	Insulation Washer 18 x 1 mm
54	RD-1920	Bracket, (Resistor Plate Mounting)
55	RD-2011	Micro Switch V-1A44
56	RD-2012	Actuator for Micro Switch
57	RD-2013	Shaft 3 x 55 mm (Micro Switch Mounting)
58	RD-2014	Metal Sleeve, Micro Switch Mounting 6 x 7 mm
59	RD-2015	"E" Ring 1.9 mm
60	RD-2016	Spark Quencher Block (RD-150)
61	RD-2017	Bracket, Micro Switch Mounting
62	RD-2020	Spring (Function Switch Knob Tension)
63	RD-2021	"E" Ring 3.2 mm
64	RD-2022	Micro Switch V-1A44 (Function Switch)
65	RD-2023	Bracket, Micro Switch Mounting
66	RD-2024	Shaft, Micro Switch Mounting 3 x 107 mm
67	RD-2025	Metal Sleeve 5 x 8.6 mm
68	RD-2026	Metal Sleeve 5 x 15.6 mm
69	RD-2027	"E" Ring 1.9 mm
70	RD-2027	Metallized Paper Capacitor 2 $\mu$ F + 1 $\mu$ F 250 WV (for Main Motor)

## SYSTEM CONTROL BLOCK (RD-144)

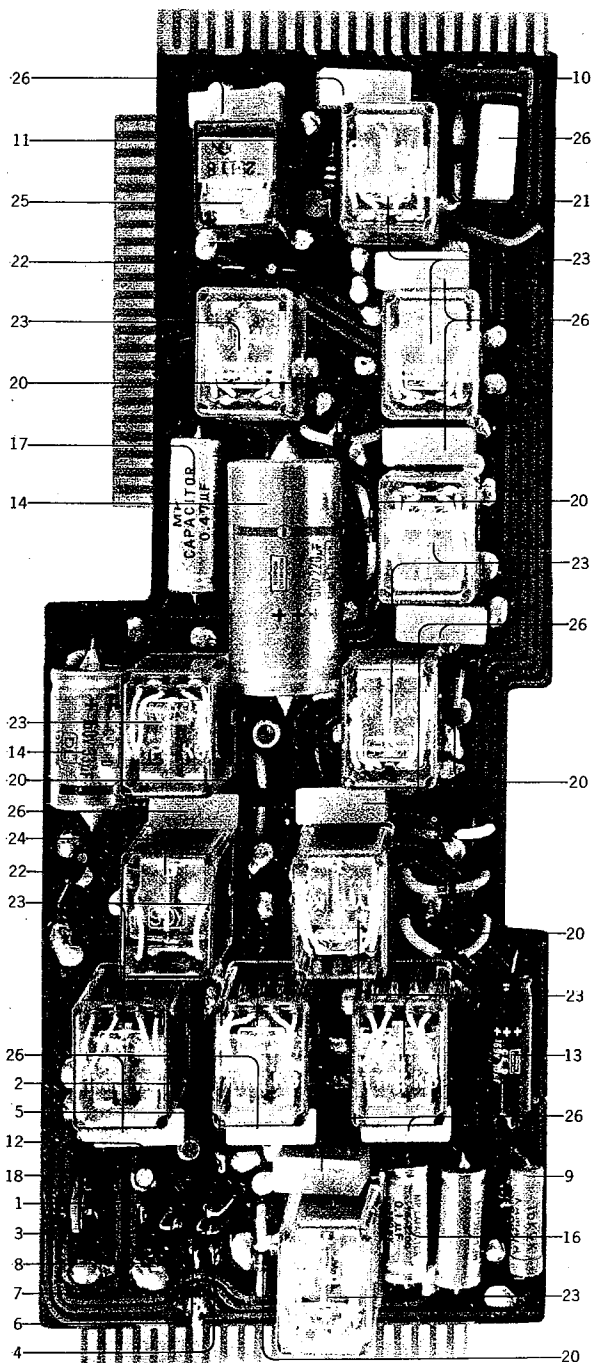

Ref. No.	Parts No.	Nomenclature
	RD-144	System Control Block
		<b>Transistor</b>
1	TR44-1	2SC372
2	TR44-2	2SC728
		<b>Carbon Resistor with Stopper</b>
3	R44-2,3	1/4 watt 1K (K)
4	R44-4	1/4 watt 6.8K (J)
5	R44-8	1/4 watt 10K (K)
6	R44-5	1/4 watt 47K (J)
7	R44-7	1/4 watt 100K (K)
8	R44-6	1/4 watt 680K (K)
9	R44-1	Metal Oxide Film Resistor 2W 15K (K)
10	R44-9	Wired Resistor 2W 10Ω
11	R44-10	Solid Resistor 68K 1/2W
		<b>Electrolytic Vertical Mounting Type Capacitor</b>
12	C44-7	10 μ 25V
13	C44-3	10 μ 160V
14	C44-1	33 μ 160V
15	C44-2	220 μ 160V
		<b>Metallized Paper Capacitor Tublar Type</b>
16	C44-5,6	0.1 μ 250V (M)
17	C44-4	0.47 μ 250V (M)
18	VR44-1	100K B Variable Resistor
19	ZD44-1	Zener Diode RD-24A
		<b>Silicon Diode</b>
20	D44-1,2,5,6,8~12	10D4
21	D44-7	10D6
22	D44-3,4	SL-150
		<b>Relay</b>
23	RL44-3~13	MY4-0-AD DC 80V
24	RL44-2	MY2-0-AD DC 34V
25	RL44-1	MHIP-0 DC 24V
26	SK44-1	Spark-killer Compound 0.1μ + 120Ω 250V

SYSTEM CONTROL BLOCK (RD-144)

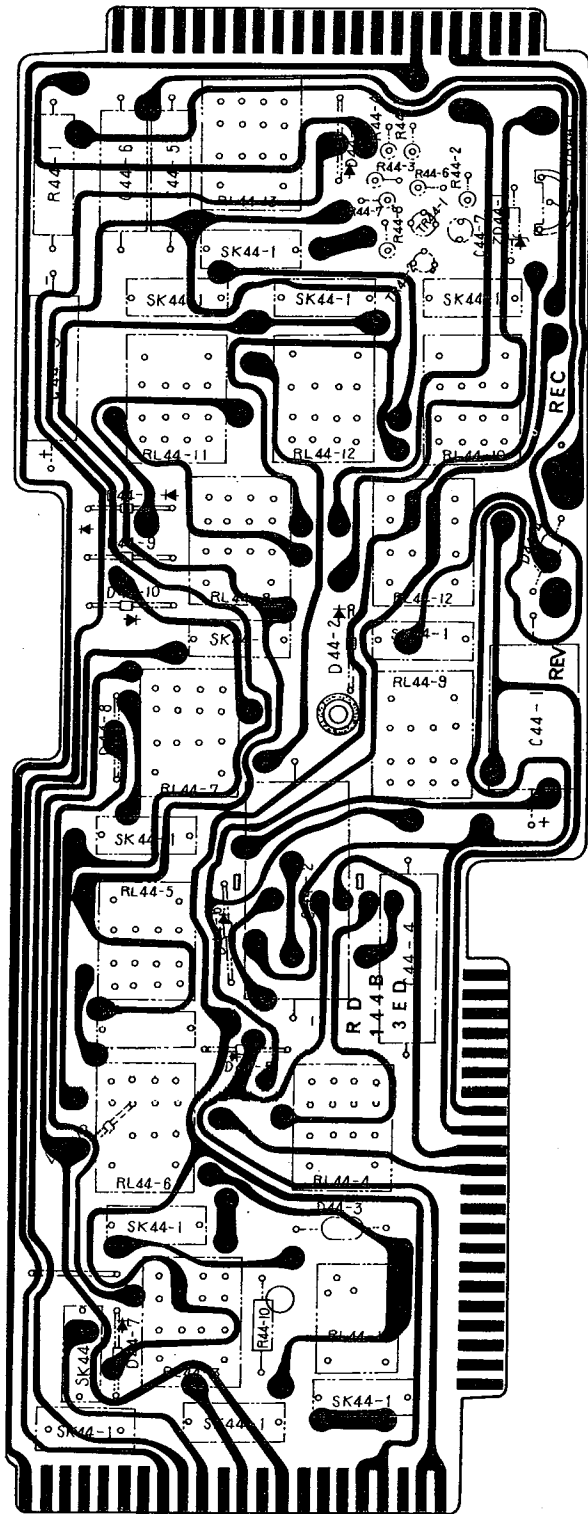
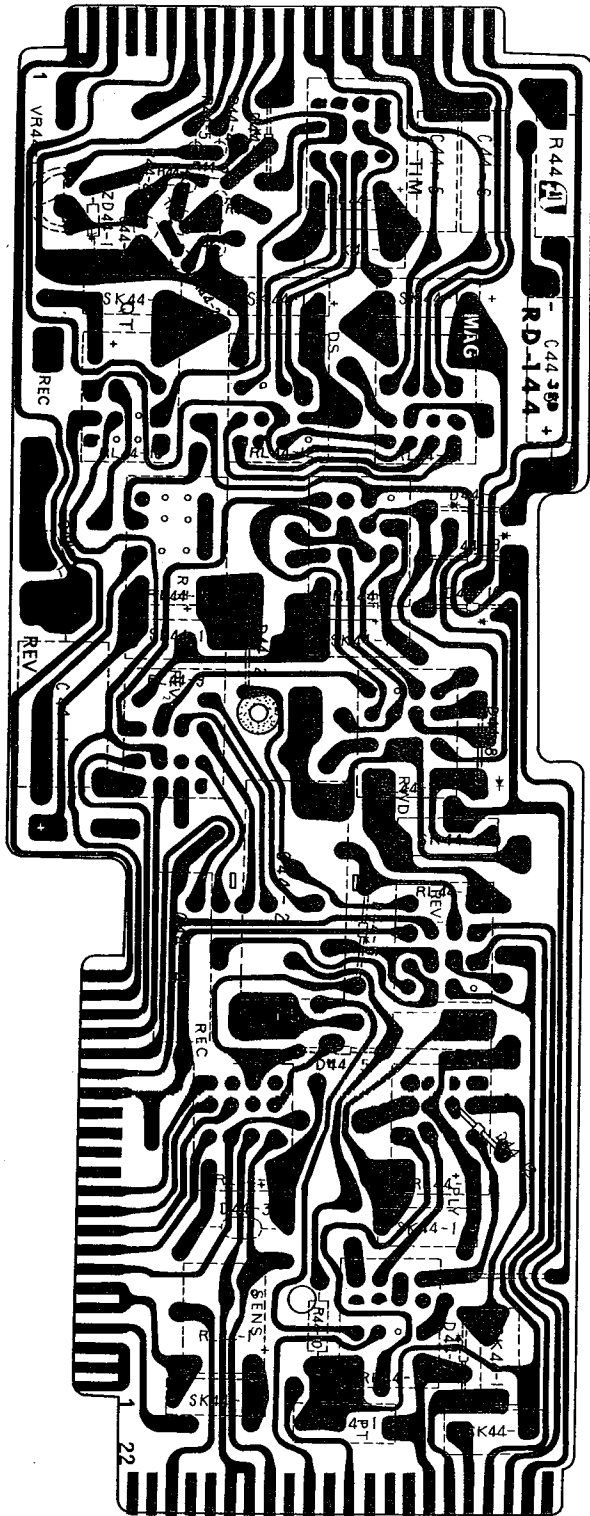

POWER SOURCE BLOCK (RD2100)

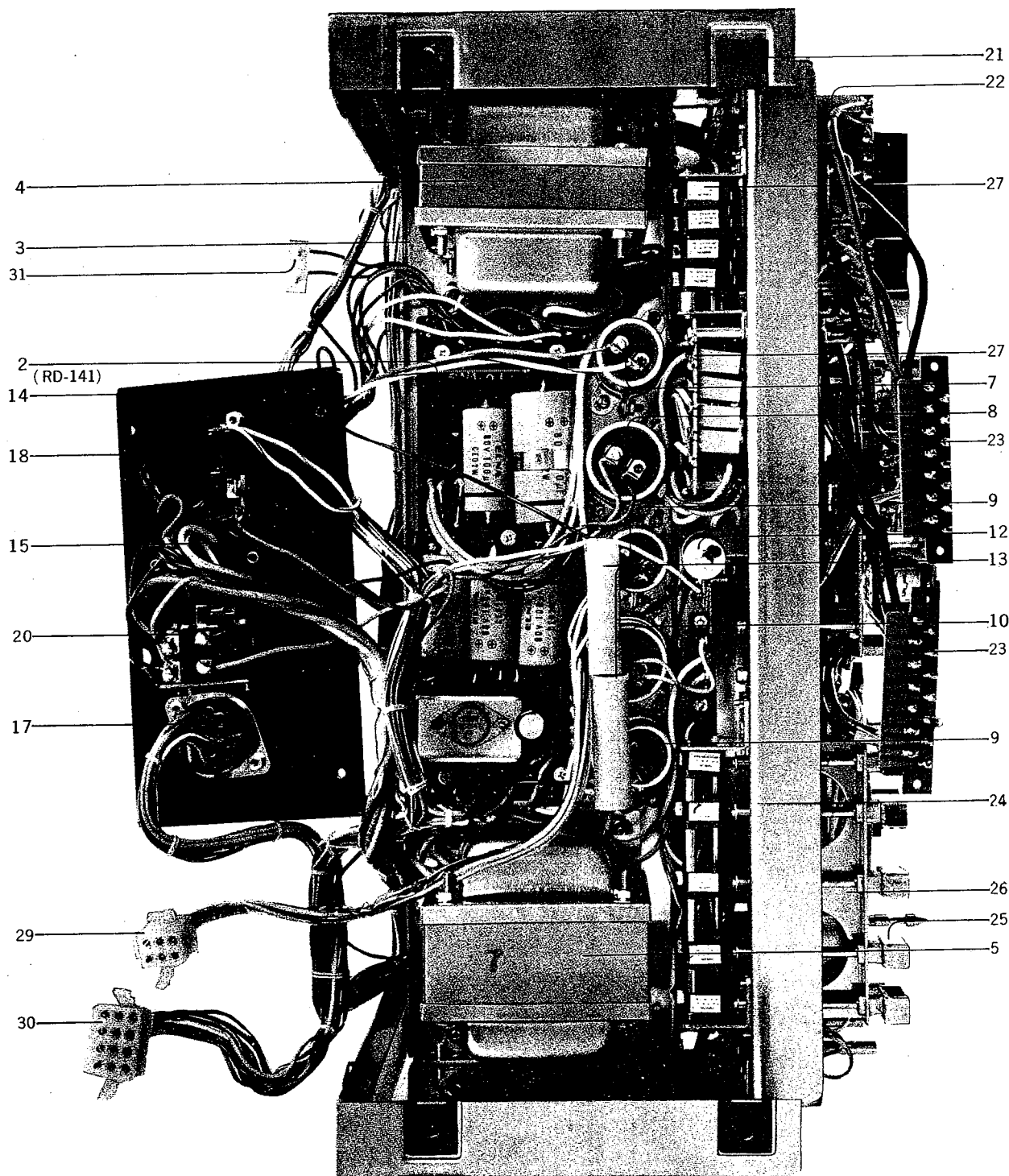

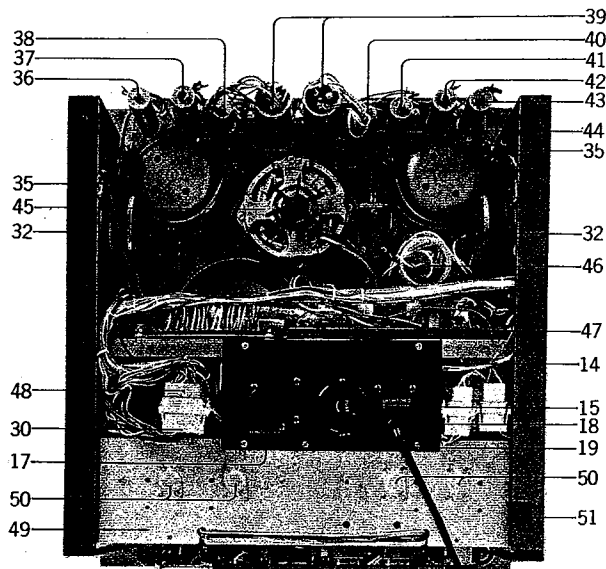

Ref. No.	Parts No.	Nomenclature
10	RD-2109	1000 $\mu$ 63V (C55-5)
11	RD-2110	Screw, round head 3 x 3 mm
12	RD-2111	Wire Wound Fixed Power Resistor 15H 570 $\Omega$
13	RD-2112	Wire Wound Resistor 4 W 4 $\Omega$ (J)
14	RD-2113	Plate, Voltage Change
15	RD-2114	Receptacle Socket (Voltage Selector)
16	RD-2115	Screw, truss head 3 x 8 mm
17	RD-2116	Socket, Remote Control
18	RD-2117	Strain Bushing for AC Cord (SR-2P-1)
19	RD-2118	AC Supply Cord
20	RD-2119	Micro Switch, Voltage Change (V-1A44)
21	RD-2120	Speed Nut
22	RD-2008	Speed Selector Switch Assy. Comp. (RD-139B)
23	RD-1182	Printed Plug 14P
24	RD-2022	Micro Switch (V-1A44)
25	RD-2018	Knob, Function Switch
26	RD-2019	Bracket, Knob Mounting
27	RD-2011	Micro Switch (V-1A44)
28	RD-2016	Spark Quencher Block (RD-150)
29	RD-2121	6P Socket
30	RD-2122	12P Socket
31	RD-2123	3P Socket
32	RD-2124	Speaker
33	RD-2126	Screw, binding head 3 x 12 mm
34	RD-2127	Lug Plate KPL1
35	RD-2128	Wire wound Resistor 3W 16 $\Omega$
36	RD-1902	Resistor, 30H 1K (J)
37	RD-1904	Resistor, 40H 230 $\Omega$ (K)
38	RD-1906	Resistor, 15H 400 $\Omega$ (K)
39	RD-1908	Metalized Paper Capacitor (Lug Tublar Type)
40	RD-1909	Resistor, 5H 1K (K)
41	RD-1911	Resistor, 20H 1.7K (K)
42	RD-1913	Resistor, 30H 650 $\Omega$ (K)
43	RD-1915	Resistor 30H 120 $\Omega$ (K)
44	RD-1400	Reel Motor Assy. Comp. (24XO)
45	RD-1500	Main Motor Assy. Comp. (16X)
46	RD-2028	Metalized Paper Capacitor 2 $\mu$ F + 1 $\mu$ F 250V
47	RD-144	System Control Block
48	RD-2341	12P Plug
49	RD-2331	Plate, Heat Sink
50	RD-2329	Transistor 2SD-130R
51	RD-2120	Speed Nut
52	RD-212	Plate, Diode Mounting
53	RD-2122	Screw, binding head 3 x 5 mm
54	RD-2123	Silicon Diode 5B2
55	RD-2124	Screw, binding head 3 x 8 mm

### POWER SOURCE BLOCK (RD-2100)

Ref. No.	Parts No.	Nomenclature
	RD-2100	Power Source Assembly Complete
1	RD-2101	Power Source Chassis Assy. Comp.
2	RD-141	Power Source Printed Board Complete
3	RD-2102	Chassis, Power Source
4	RD-2103	Power Transformer (RD-T1)
5	RD-2104	Power Transformer (RD-T3)
6	RD-2105	Screw, pan head 4 x 8 mm
7	RD-2106	Electrolytic Capacitor 1000 $\mu$ 50V (C55-1)
8	RD-2107	Electrolytic Capacitor 220 $\mu$ 160V (C55-2)
9	RD-2108	Electrolytic Capacitor 1000 $\mu$ 35V (C55-3,4)

## POWER SOURCE PRINTED BOARD (RD-141)

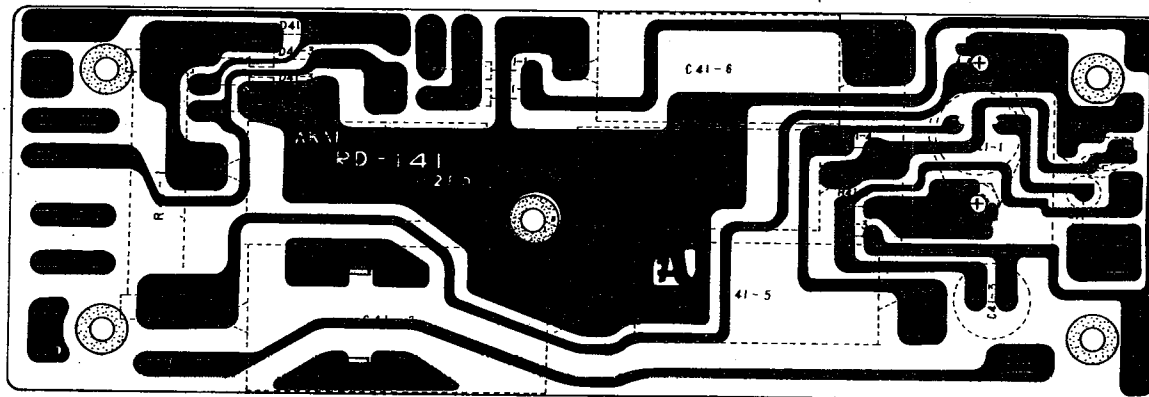
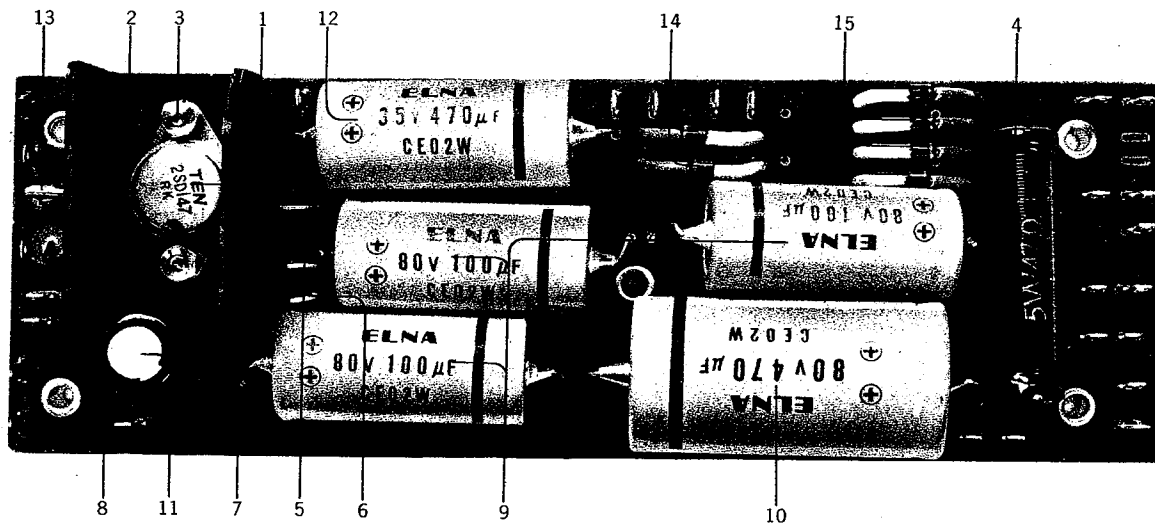

## POWER SOURCE PRINTED BOARD (RD-141)

Ref. No.	Parts No.	Nomenclature	Ref. No.	Parts No.	Nomenclature
	RD-141	Power Source Printed Board Complete			
1	TR41-1	Transistor 2SD147	9	C41-1,4,5	Electrolytic, Tubular Type Capacitor 100 µ 80V
2	H41-1	Transistor Cooler RD-134 for 2SD147	10	C41-2	470 µ 80V
3	S41-1	Screw, binding head 3 x 8 mm	11	C41-3	100 µ 50V
4	R41-1	Wire wound resistor 5W 47 Ω	12	C41-6	470 µ 35V
		<b>Carbon Resistor with stopper</b>	13	VR41-1	5KB Semi-variable Resistor
5	R41-2	1/4 watt 4.7K (K)	14	D41-1,2	Silicon Diode SW-05-02
6	R41-3	1/4 watt 5.6K (K)	15	D41-3	10D4
7	R41-4	1/4 watt 2.7K (K)		S41-2	Screw, flat head 3 x 12mm
8	R41-5	Solid Resistor 1 watt 10 Ω (K)			

**OSC PRINTED  
CIRCUIT BOARD  
(RD-530)**

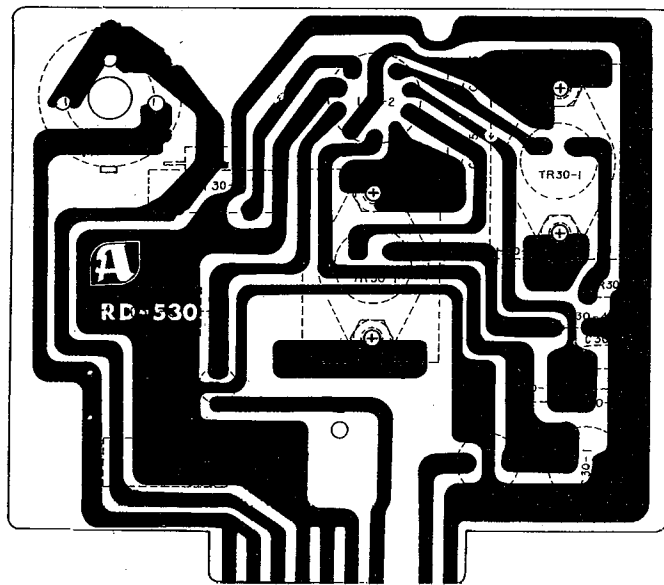
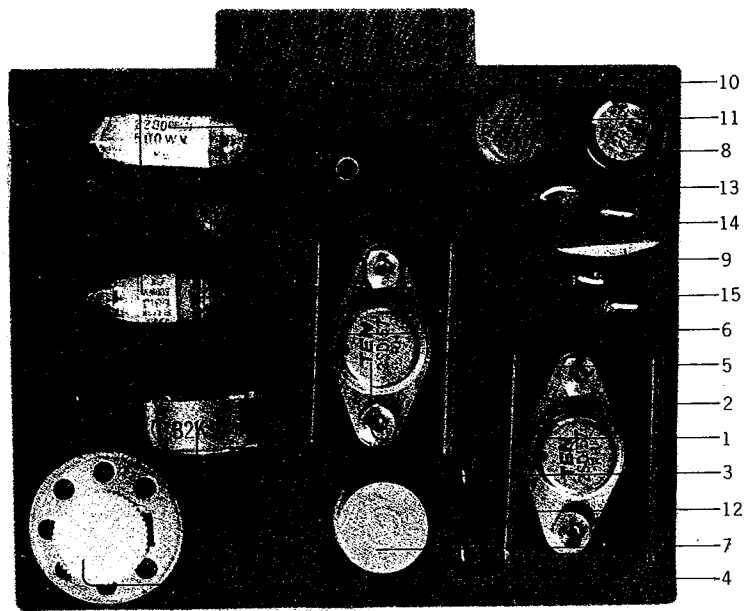

**OSC PRINTED CIRCUIT BOARD (RD-530)**

Ref. No.	Parts No.	Nomenclature	Ref. No.	Parts No.	Nomenclature
	RD-530	OSC Printed Circuit Board Complete			
1	TR30-1	Transistor 2SD157	9	C30-2	Ceramic Condenser vertical mounting type 0.1 $\mu$ 50V
2	H30-1	Transistor Cooler for 2SD157	10	C30-3	Plastic Film Condenser 680P 500V
		Wire wound semi-variable Resistor	11	C30-4	2200P 500V
3	VR30-1	1.5W 2KB WR185-2K(PH)	12	C30-5,6	Mylar Condenser, tublar type 0.0056 $\mu$ (K) 100V
4	VR30-2	1.5W 5KB WR241-5K (PVB)			Carbon Resistor with Stopper
		Inductive Coil	13	R30-1	1/4 watt 22K
5	L30-1	FL11H 10mH	14	R30-2	1/4 watt 1K
6	L30-3	FL-7H 220 $\mu$ H	15	R30-3,4	1/4 watt 10 $\Omega$
7	L30-2	OSC Coil MC-152			
8	C30-1	Electrolytic Capacitor, vertical mounting type 100 $\mu$ 50V			

AUTOMATIC DUST MINDER PRINTED CIRCUIT BOARD (RD-271)

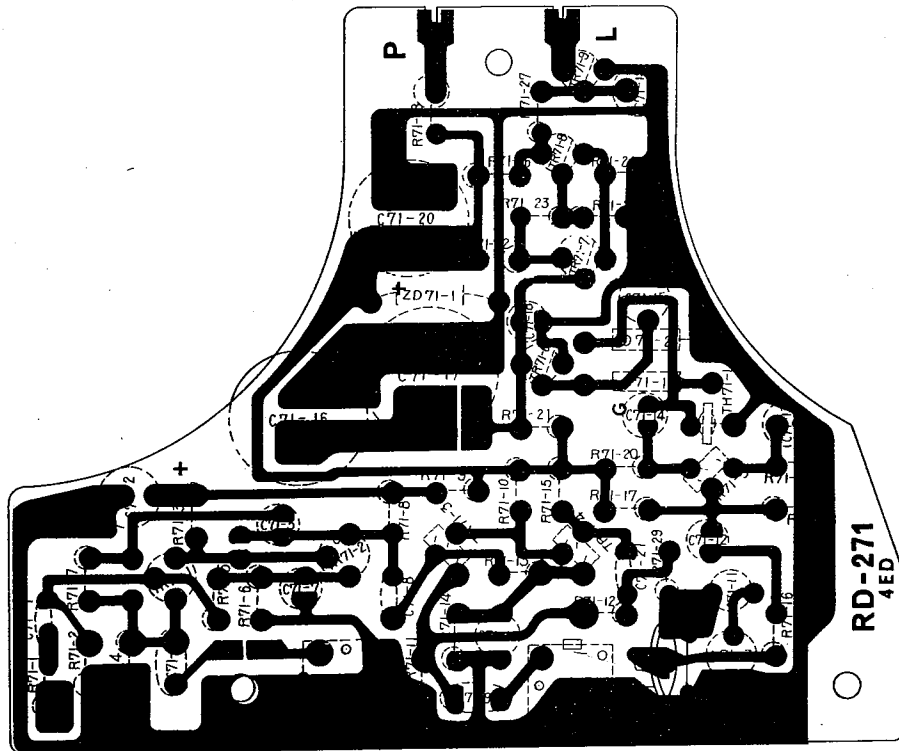
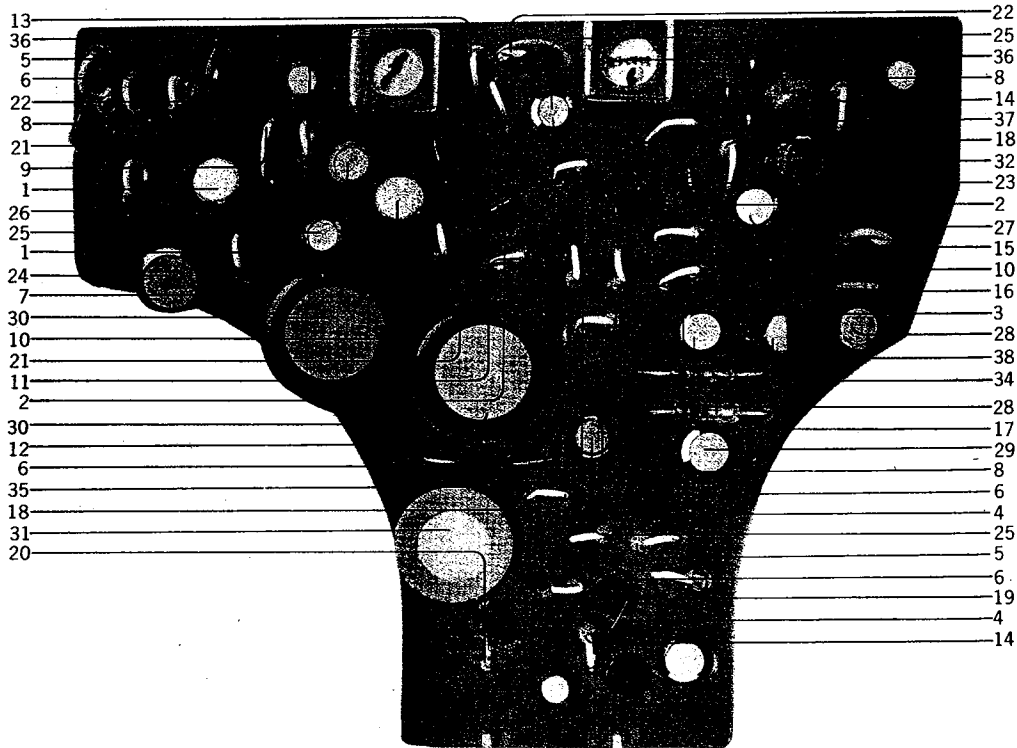



## AUTOMATIC DUST MINDER PRINTED CIRCUIT BOARD (RD-271)

Ref. No.	Parts No.	Nomenclature
	RD-271	Automatic Dust Minder Printed Circuit Board Complete
		<b>Transistor</b>
1	TR71-1,2	2SC650 (B)
2	TR71-3,4	2SC458 LG(B)
3	TR71-5	2SC458 (B)
4	TR71-6~9	2SC372
		<b>Carbon Resistor with Stopper</b>
5	R71-1,6,25	1/4 watt 10K (K)
6	R71-2,13, 21,23	1/4 watt 47K (K)
7	R71-3	1/4 watt 100K (K)
8	R71-4,7, 12,15	1/4 watt 6.8K (K)
9	R71-5	1/4 watt 68K (K)
10	R71-8,17	1/4 watt 15K (K)
11	R71-9,14	1/4 watt 1K (K)
12	R71-10	1/4 watt 22K (K)
13	R71-11	1/4 watt 330 $\Omega$
14	R71-16,27	1/4 watt 3.3K (K)
15	R71-18	1/4 watt 5.7K (K)
16	R71-19	1/4 watt 470 $\Omega$ (K)
17	R71-20	1/4 watt 1.5K (K)
18	R71-22, 26,29	1/4 watt 2.2K (K)
19	R71-24	1/4 watt 47 $\Omega$ (K)
20	R71-28	<b>Solid Resistor</b> 1/2 watt 470 $\Omega$ (K)
		<b>Mylar Condenser, vertical mounting type</b>
21	C71-1,8	0.01 $\mu$ 50V
22	C71-3,9	0.033 $\mu$ 50V
23	C71-21	0.022 $\mu$ 50V
		<b>Electrolytic Capacitor, vertical mounting type</b>
24	C71-2	47 $\mu$ 16V
25	C71-5,10,18	10 $\mu$ 10V
26	C71-7	1 $\mu$ 17V
27	C71-12	1 $\mu$ 10V
28	C71-13,14	1 $\mu$ 16V
29	C71-15,19	33 $\mu$ 3.15V
30	C71-16,17	1000 $\mu$ 3.15V
31	C71-20	220 $\mu$ 16V
32	C71-11	<b>Styrol Capacitor</b> 470P 50V
33	VR71-1	10K (B) Semi-variable Resistor
34	D71-1	<b>Germanium Diode</b> IN34A
35	ZD71-1	Zener Diode IN759A
36	L71-1,2	DM Coil, 100mH M-10
37	L71-3	Inductive Coil FL-7H 5.6mH
38	TH71-1	<b>Thermister 41D26</b>



## PLAYBACK PRINTED CIRCUIT BOARD (RD-529)

Ref. No.	Parts No.	Nomenclature
	RD-529	Playback Printed Circuit Board Complete
		<b>Transistor</b>
1	TR29-1,2	2SC458LG ©
2	TR29-3,4,5	2SC372
		<b>Carbon Resistor with Stopper (Noiseless)</b>
3	R29-1	1/4 watt 180K
4	R29-8	1/4 watt 270K
5	R29-10	1/4 watt 220K
		<b>Carbon Resistor with Stopper</b>
6	R29-2	1/4 watt 10K
7	R29-3	1/4 watt 270 Ω
8	R29-4,22, 23	1/4 watt 100K
9	R29-5	1/4 watt 18K
10	R29-6,12	1/4 watt 6.8K
11	R29-7	1/4 watt 3.9K
12	R29-9	1/4 watt 12K
13	R29-11	1/4 watt 47K
14	R29-13	1/4 watt 15K
15	R29-14	1/4 watt 220 Ω
16	R29-15,16	1/4 watt 1.5K
17	R29-17	1/4 watt 180 Ω
18	R29-18	1/4 watt 390 Ω
19	R29-19	1/4 watt 68K
20	R29-20	1/4 watt 6.2K
21	R29-21,24	1/4 watt 3.3K
22	R29-25	1/4 watt 2.2K
23	R29-26	1/4 watt 1K
		<b>Electrolytic Capacitor, Vertical Mounting Type</b>
24	C29-1,11	10 μ 10V
25	C29-2,12	22 μ 6.3V
26	C29-4	100 μ 25V
27	C29-6	47 μ 6.3V
28	C29-9,15, 17,18	10 μ 25V
29	C29-14	100 μ 10V
30	C29-19	100 μ 50V
31	C29-20	0.001 μ 50V
		<b>Mylar Condenser Vertical Mounting Type</b>
32	C29-3,21	0.001 μ 50V
33	C29-5,16	0.0022 μ 50V
34	C29-7	0.01 μ 50V (J)
35	C29-13	0.01 μ 50V
		<b>Minature Film Mica Condenser</b>
36	C29-8	150P 50V
37	C29-10	270P 50V
38	VR29-1	50KB Semi-variable Resistor
39	L29-1	DM Coil 10mH (Inductive Coil FL9H 10mH (J))

RECORD PRINTED CIRCUIT BOARD (RD-528)

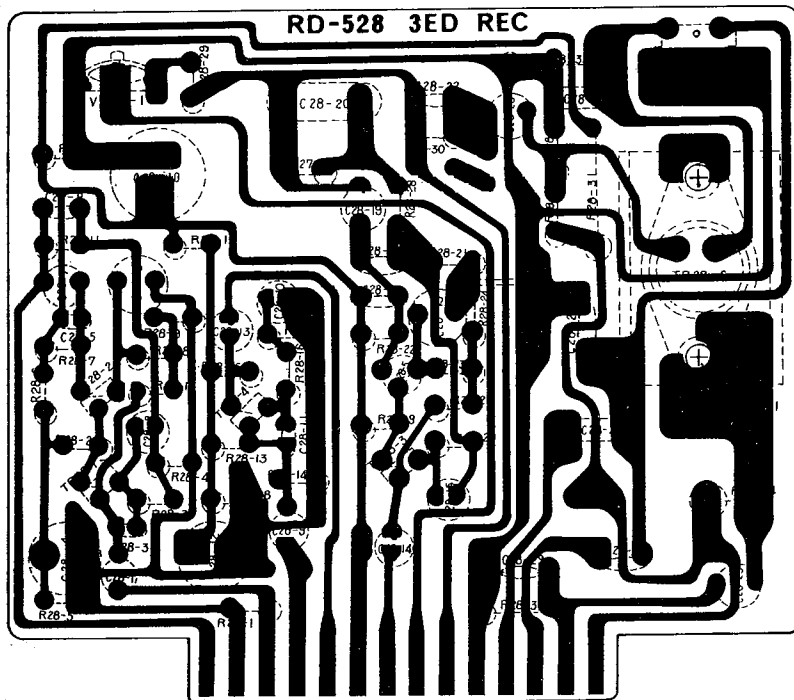
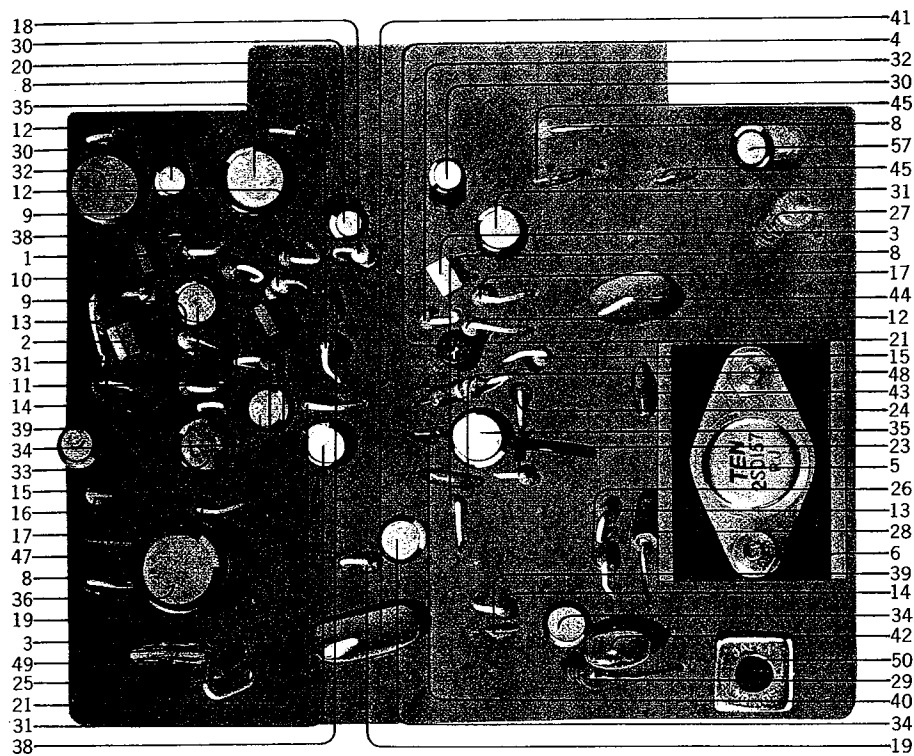

# RECORD PRINTED CIRCUIT BOARD (RD-528)

Ref. No.	Parts No.	Nomenclature	Ref. No.	Parts No.	Nomenclature
	RD-528	Record Printed Circuit Board Complete	50	L28-1	Peaking Coil AK1206 (P-10L 650 $\mu$ H)
		Transistor			
1	TR28-1	2SC-458LG (B) (C)			
2	TR28-2	2SC-458LG (C)			
3	TR28-3,4	2SC-458LG (B)			
4	TR28-5	2SC-372			
5	TR28-6	2SD-157			
6	H28-1	Transistor Cooler for 2SD-157			
7	S28-1	Screw, round head 3 x 8 mm			
		Carbon Resistor with Stopper			
8	R28-1,26, 28,36	1/4 watt 10K			
9	R28-2,10,13	1/4 watt 180K			
10	R28-3,37	1/4 watt 8.2K			
11	R28-4	1/4 watt 330 $\Omega$			
12	R28-5,18,25	1/4 watt 100K			
13	R28-6,7,32	1/4 watt 18K			
14	R28-8,30	1/4 watt 4.7K			
15	R28-9,23	1/4 watt 1.8K			
16	R28-11	1/4 watt 27K			
17	R28-12,20	1/4 watt 5.6K			
18	R28-14	1/4 watt 47K			
19	R28-15,27	1/4 watt 12K			
20	R28-16	1/4 watt 1K			
21	R28-17,22	1/4 watt 3.9K			
22	R28-19	1/4 watt 120K			
23	R28-21	1/4 watt 390 $\Omega$			
24	R28-24	1/4 watt 560 $\Omega$			
25	R28-29	1/4 watt 22K			
26	R28-33	1/4 watt 3K (J)			
27	R28-34	Metal Oxide Film Resistor 2W 1K			
28	R28-31	Solid Resistor 1/2 watt 2.7K			
29	R28-35	Solid Resistor 1/2 watt 270 $\Omega$			
		Electrolytic Capacitor, Vertical Mounting Type			
30	C28-1,9,14	10 $\mu$ 10V			
31	C28-2,10,15	22 $\mu$ 6.3V			
32	C28-4	33 $\mu$ 25V			
33	C28-6	47 $\mu$ 6.3V			
34	C28-7,13, 19,23	10 $\mu$ 25V			
35	C28-12,18	47 $\mu$ 25V			
36	C28-16	100 $\mu$ 50V			
37	C28-25	4.7 $\mu$ 50V			
		Mylar Condenser, Vertical Mounting Type			
38	C28-3,11	0.001 $\mu$ 50V			
39	C28-5,22	0.0022 $\mu$ 50V			
40	C28-17	47 $\mu$ 10V			
41	C28-20	0.47 $\mu$ 35V			
42	C28-24	0.12 $\mu$ 50V			
43	C28-26	0.068 $\mu$ 50V			
44	C28-27	0.22 $\mu$ 35V			
45	C28-28,29	0.012 $\mu$ 50V			
46	C28-30	0.022 $\mu$ 50V			
47	C28-8	Film Mica Condenser 150P 50V			
48	C28-21	Minature Film Mica Condenser 150P 50V			
49	VR28-1	20KB Semi-variable Resistor			

MAIN AMPRIER PRINTED CIRCUIT BOARD (RD-531)

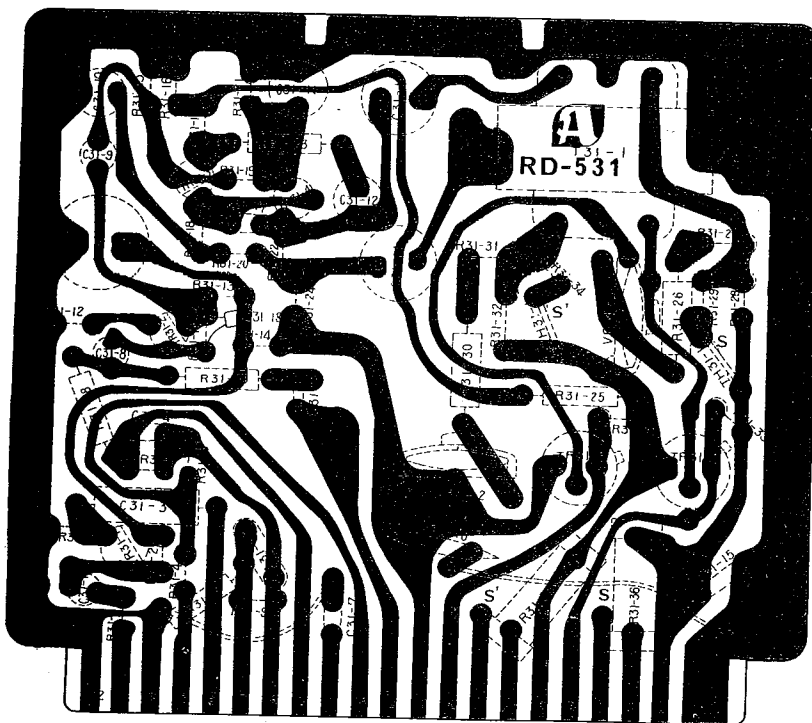
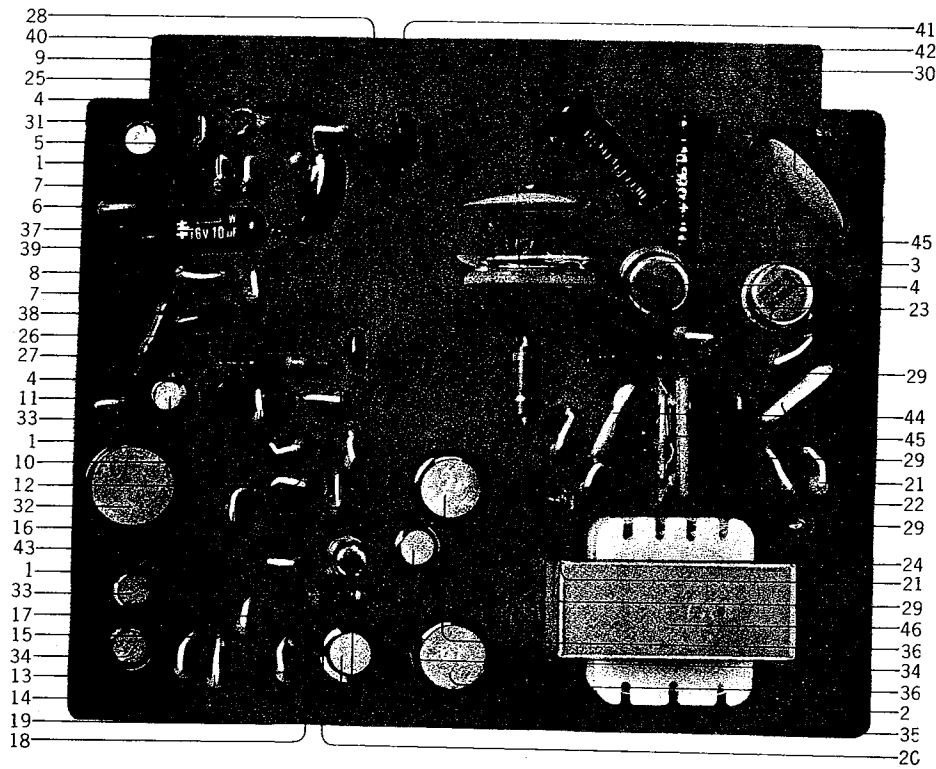

## MAIN AMPLIFIER PRINTED CIRCUIT BOARD (RD-531)

Ref. No.	Parts No.	Nomenclature
	RD-531	Main Amplifier Printed Circuit Board Complete
		<b>Transistor</b>
1	TR31-1,2,3	2SC828-R
2	TR31-4	2SC538-R.O.
3	TR31-5,6	2SC696-E.B.
		<b>Carbon Resistor with Stopper</b>
4	R31-1,14, 22,25	1/4 watt 1 K
5	R31-2	1/4 watt 220K
6	R31-3	1/4 watt 2.2K
7	R31-4,5	1/4 watt 5.6K
8	R31-6	1/4 watt 130K
9	R31-9	1/4 watt 3.6K
10	R31-11	1/4 watt 470K
11	R31-12	1/4 watt 750 $\Omega$
12	R31-13	1/4 watt 5.6K
13	R31-15	1/4 watt 39K
14	R31-16	1/4 watt 56 $\Omega$
15	R31-17	1/4 watt 110 $\Omega$
16	R31-18	1/4 watt 33K
17	R31-19	1/4 watt 120K
18	R31-20	1/4 watt 12K
19	R31-21	1/4 watt 510 $\Omega$
20	R31-23	1/4 watt 3K
21	R31-28,32	1/4 watt 150 $\Omega$
22	R31-29	1/4 watt 100 $\Omega$
23	R31-33,35	1/4 watt 680 $\Omega$
24	R31-34	1/4 watt 100 $\Omega$
		<b>Carbon Resistor</b>
25	R31-7	1/4 watt 1.1K
26	R31-8	1/4 watt 6.8K
27	R31-10	1/4 watt 10K
28	R31-24	1/4 watt 1K
		<b>Solid Resistor</b>
29	R31-26,27, 30,31	1/2 watt 750 $\Omega$
		<b>Wire wound Resistor</b>
30	R31-36,37	1 watt 0.39 $\Omega$
		<b>Electrolytic Capacitor, Vertical Mounting Type</b>
31	C31-1	1 $\mu$ 16V
32	C31-2	220 $\mu$ 25V
33	C31-8,9	22 $\mu$ 25V
34	C31-10,12	10 $\Omega$ 25V
35	C31-11	100 $\mu$ 6.3V
36	C31-13,14	100 $\mu$ 25V
		<b>Electrolytic Capacitor, Tublar Type</b>
37	C31-3	10 $\mu$ 16V
		<b>Mylar Condenser</b>
38	C31-4	0.022 $\mu$ 50V
39	C31-5	0.22 $\mu$ 35V
40	C31-6	0.0022 $\mu$ 50V
41	C31-7	0.027 $\mu$ 50V
42	C31-15,16	Styrol Condenser 0.1 $\mu$ 50V
43	C31-17,18	Film Condenser 100P 50V
44	TH31-1	Thermister D41A
45	VR31-1,2	200 $\Omega$ B Semi-variable Resistor
46	T31-1	In-put Transformer N28-6067AT

MONITOR SWITCH PRINTED CIRCUIT BOARD (RD-523)

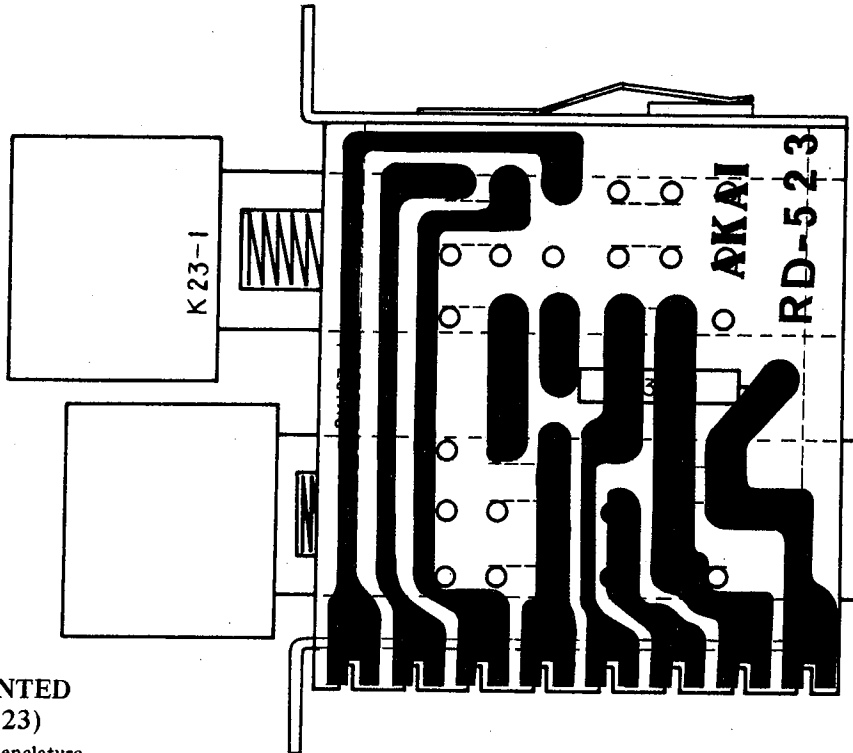
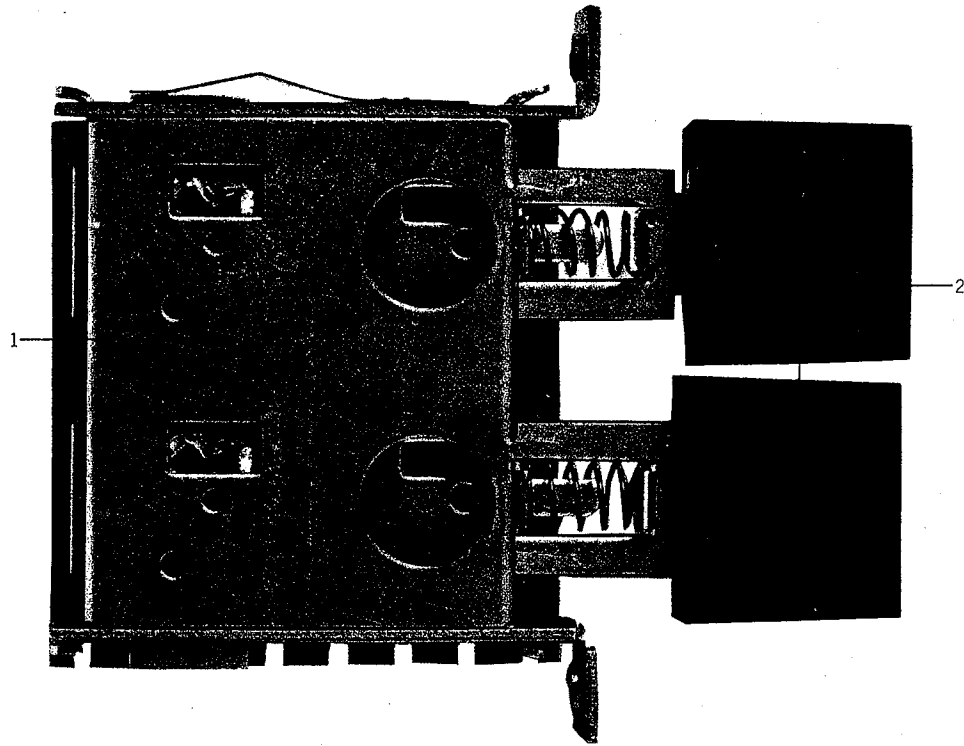

MONITOR SWITCH PRINTED CIRCUIT BOARD (RD-523)

Ref. No.	Parts No.	Nomenclature
	RD-523	Monitor Switch Printed Circuit Board Assembly Complete
1	SW23-1	Monitor Push Switch UM21220J
2	K23-1	Knob, Monitor Switch
3	R23-1	Carbon Resistor 1/4 watt 68K



TRACK SELECTOR PRINTED CIRCUIT BOARD (RD-522)

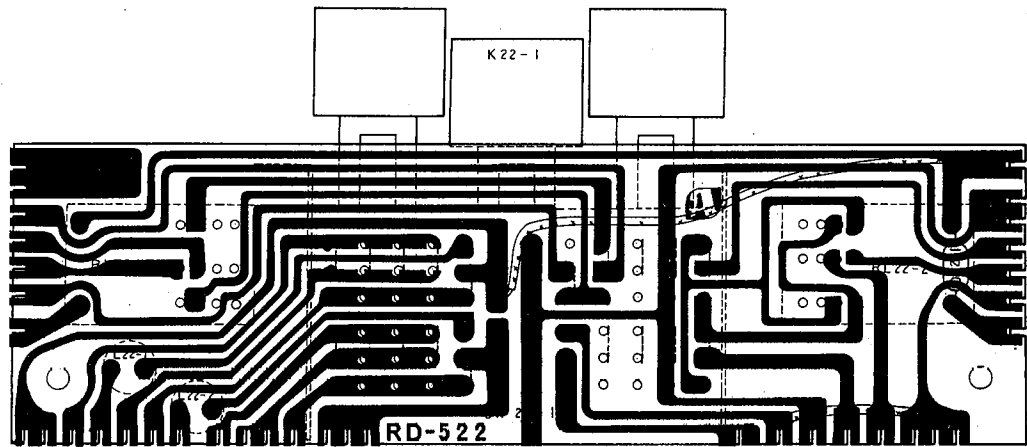
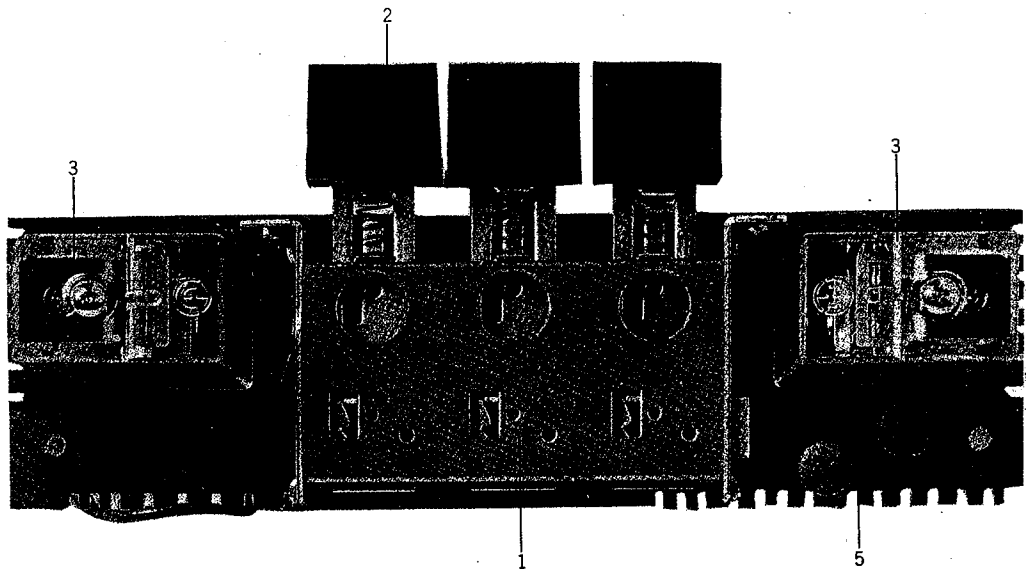

TRACK SELECTOR PRINTED  
CIRCUIT BOARD (RD-522)

Ref. No.	Parts No.	Nomenclature
	RD-522	Track Selector Printed Circuit Board Assembly Complete
1	SW22-1	Track Selector Switch UM32420C.
2	K22-1	Knob, Track Selector Switch

Ref. No.	Parts No.	Nomenclature
3	RL22-1,2	Relay, MQ-1404
4	D22-1	Silicon Diode SL-150
5	L22-1,2	Inductive Coil FL-9H 680mH



## COM PRINTED CIRCUIT BOARD BLOCK (RD-570)

Ref. No.	Parts No.	Nomenclature
	RD-570	COM Printed Circuit Board Complete
		<b>Transistor</b>
1	TR70-1	2SC828 (T)
2	TR70-2,3	2SC372
3	TR70-4,7,8	2SC538A (Q)
4	TR70-5	2SB75A (B)
5	TR70-6	2SB77A (B)
6	VR70-1	100K (B) Semi-variable Resistor
7	ZD70-1	Zener Diode IN 759A
8	D70-1,2,3	Germanium Diode IN34A
		<b>Carbon Resistor with Stopper</b>
9	R70-1,7,10	1/4 watt 47K
10	R70-2	1/4 watt 68K
11	R70-3	1/4 watt 15K
12	R70-4,11, 14,19,22	1/4 watt 10K
13	R70-5	1/4 watt 1.8K
14	R70-6	1/4 watt 560 $\Omega$
15	R70-8,12	1/4 watt 2.2K
16	R70-9	1/4 watt 47 $\Omega$
17	R70-13	1/4 watt 22K
18	R70-15, 20,24	1/4 watt 4.7K
19	R70-16	1/4 watt 1K
20	R70-17,26	1/4 watt 100 $\Omega$
21	R70-18	1/4 watt 33 $\Omega$
22	R70-23	1/4 watt 33K
23	R70-25	1/4 watt 470 $\Omega$
24	RL70-1	Relay MH2PM-0 with socket
		<b>Electrolytic Capacitor, vertical mounting type</b>
25	C70-1,8,9	1 $\mu$ 50V
26	C70-2	33 $\mu$ 3.15V
27	C70-3	100 $\mu$ 25V
28	C70-4,6	0.47 $\mu$ 50V
29	C70-5	4.7 $\mu$ 16V
		<b>Mylar Condenser, vertical mounting type</b>
30	C70-10	0.047 $\mu$ 50V

C.O.M. SET SWITCH PRINTED CIRCUIT BOARD (RD-525)

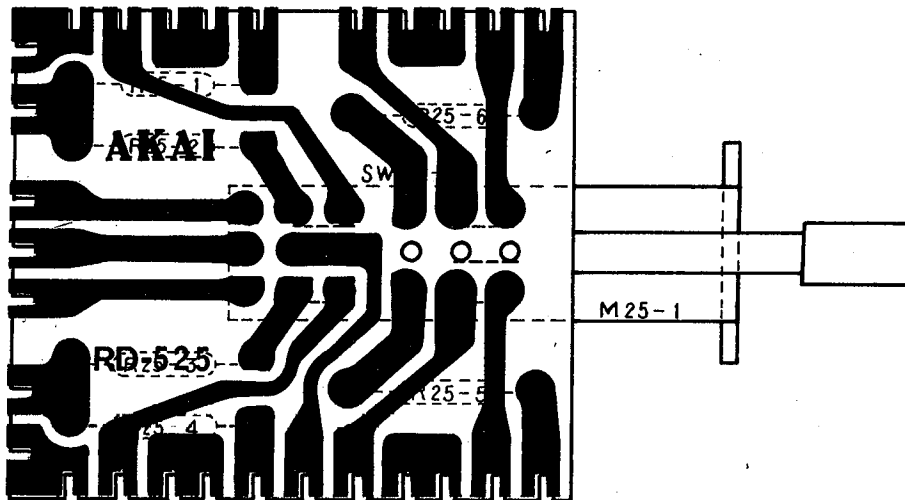
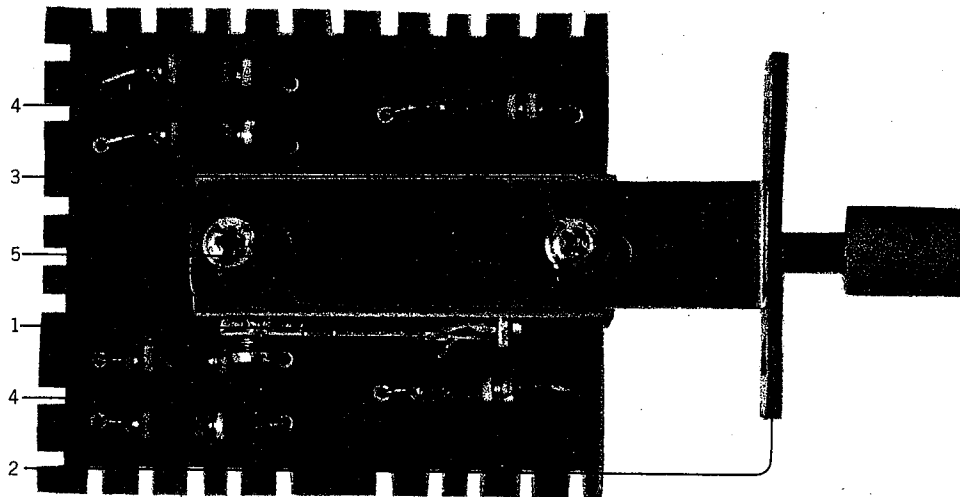

C.O.M. SET SWITCH PRINTED CIRCUIT BOARD (RD-525)

Ref. No.	Parts No.	Nomenclature	Ref. No.	Parts No.	Nomenclature
	RD-525	C.O.M. Set Switch Printed Circuit Assembly Complete	3	S25-1	Screw, round head 2.6 x 4 mm
1	SW25-1	C.O.M. Set Switch UEG-62	4	R25-1,2,3,4	Carbon Resistor 1/4 watt 47K
2	M25-1	Bracket, C.O.M' Set Switch Printed Circuit Board Mounting	5	R25-5,6	Carbon Resistor 1/4 watt 100K

C.O.M. MECHANIC BLOCK (RD-2200)

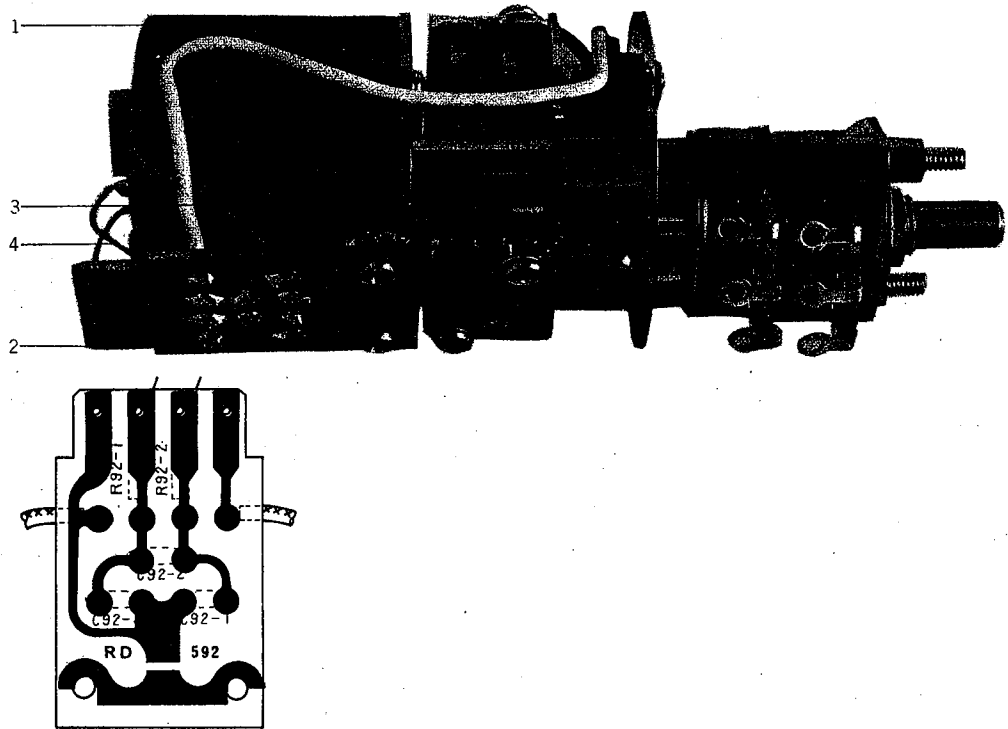

C.O.M. MECHANIC BLOCK (RD-2200)

Ref. No.	Parts No.	Nomenclature
	RD-2200	C.O.M. Volume Assy. with Micro Motor (FM-36K) contained in Rubber Cover
1	RD-2201	Micro Motor (FM-36K)
2	RD-2202	C.O.M. Terminal Circuit Board Comp. (RD-592) without Resistor

Ref. No.	Parts No.	Nomenclature
3	C92-1,2,3	Ceramic Condenser 0.1 $\mu$ 50V
4	R92-1,2	Solid Resistor 1/4 watt 33 $\Omega$ (K)

# SPARK QUENCHER & MICRO SWITCH BLOCK (RD-150B)

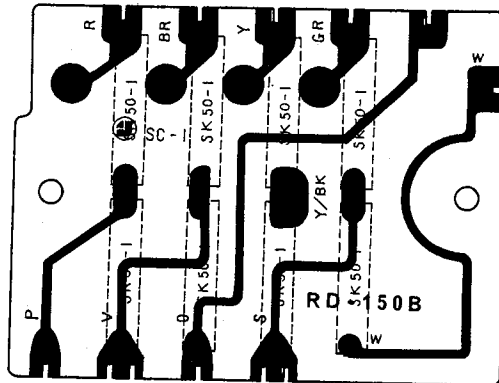
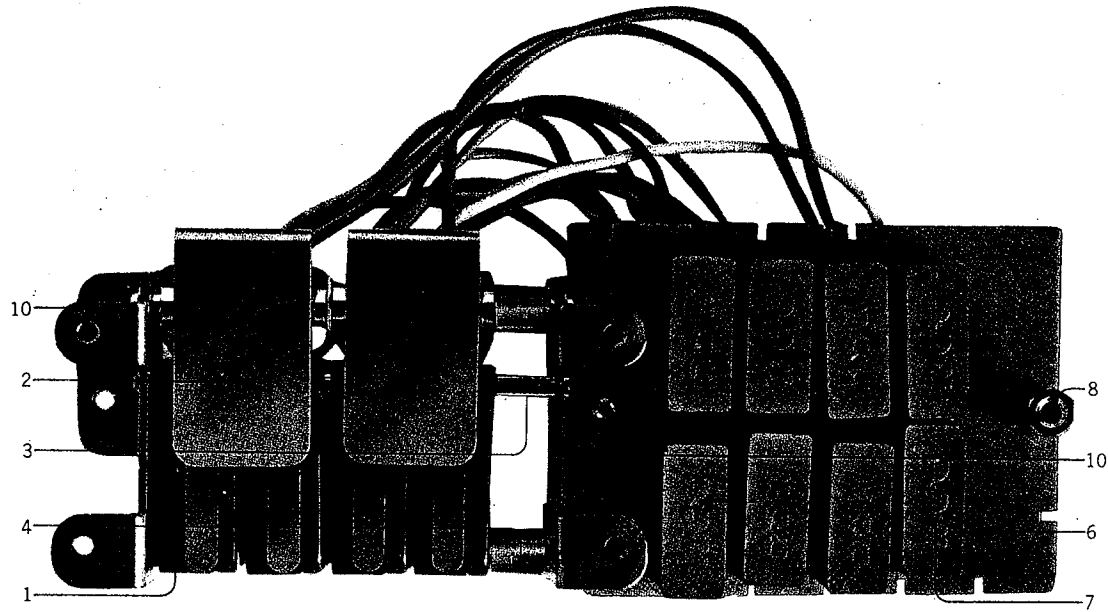

## SPARK QUENCHER & MICRO SWITCH BLOCK (RD-150B)

Ref. No.	Parts No.	Nomenclature	Ref. No.	Parts No.	Nomenclature
	RD-150B	Spark Quencher and Micro Switch Assembly Complete	6	RD-2016	Spark Quencher Block (RD-150)
1	RD-2011	Micro Switch V-1A44	7	SK50-1	Spark Quencher Compound 0.1 $\mu$ + 120 $\Omega$
2	RD-2012	Actuator for Micro Switch	8	P50-1	Prop (hex.) for Printed Circuit Board
3	RD-2013	Shaft 3 x 55 mm (Micro Switch Mounting)	9	S50-1	Screw, binding head 3 x 5 mm
4	RD-2014	Metal Sleeve, Micro Switch Mounting 6 x 7 mm	10	RD-2017	Bracket, Micro Switch Mounting
5	RD-2015	"E" Ring 1.9 mm			

## SPEED SELECTOR SWITCH BLOCK (RD-139B)

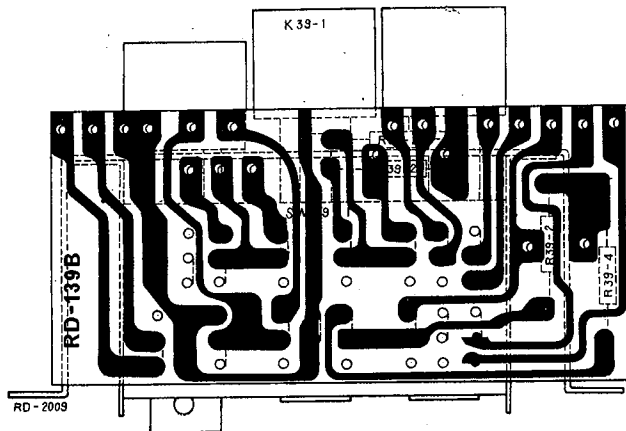
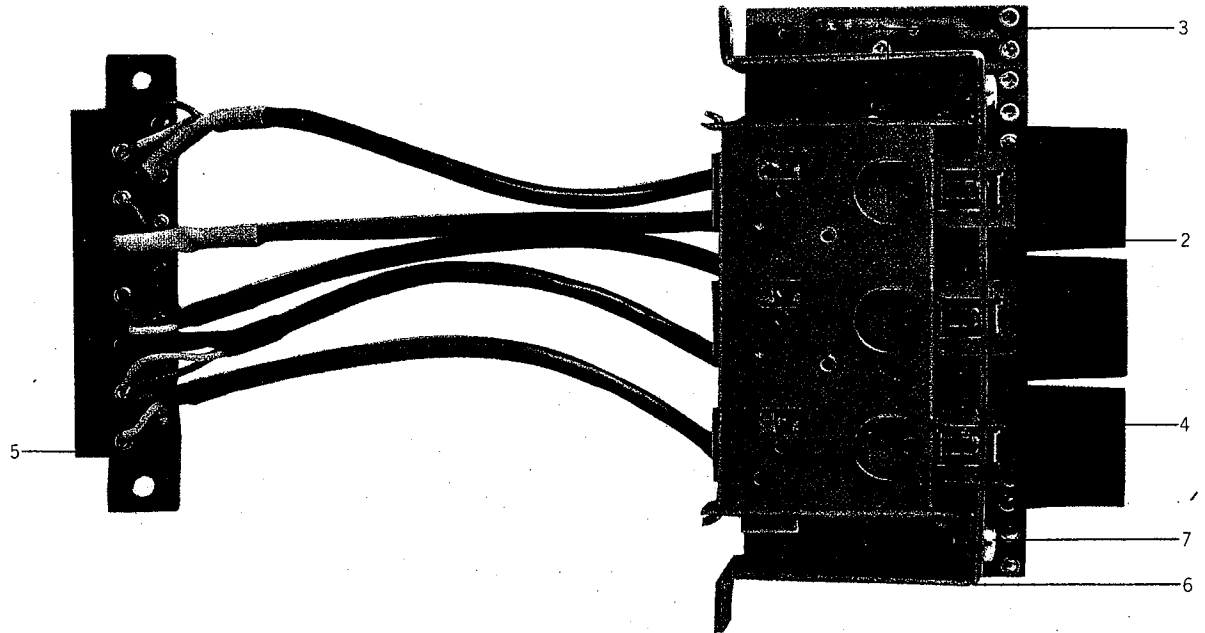

## SPEED SELECTOR SWITCH BLOCK (RD-139B)

Ref. No.	Parts No.	Nomenclature	Ref. No.	Parts No.	Nomenclature
1	RD-2008	Speed Selector Switch Assembly Complete (RD-139B)	4	K39-1	Knob, Speed Selector Switch
2	RD39-1,2	Carbon Resistor 1/4 W 36K (J)	5	P39-1	Printed Plug 14P
3	RD39-3,4	Carbon Resistor 1/4 w 11K (J)	6	RD-2009	Bracket, Speed Selector Switch Mounting
			7	RD-2010	Screw, pan head 3 x 5 mm

AMPLIFIER CHASSIS BLOCK (RD-2300)

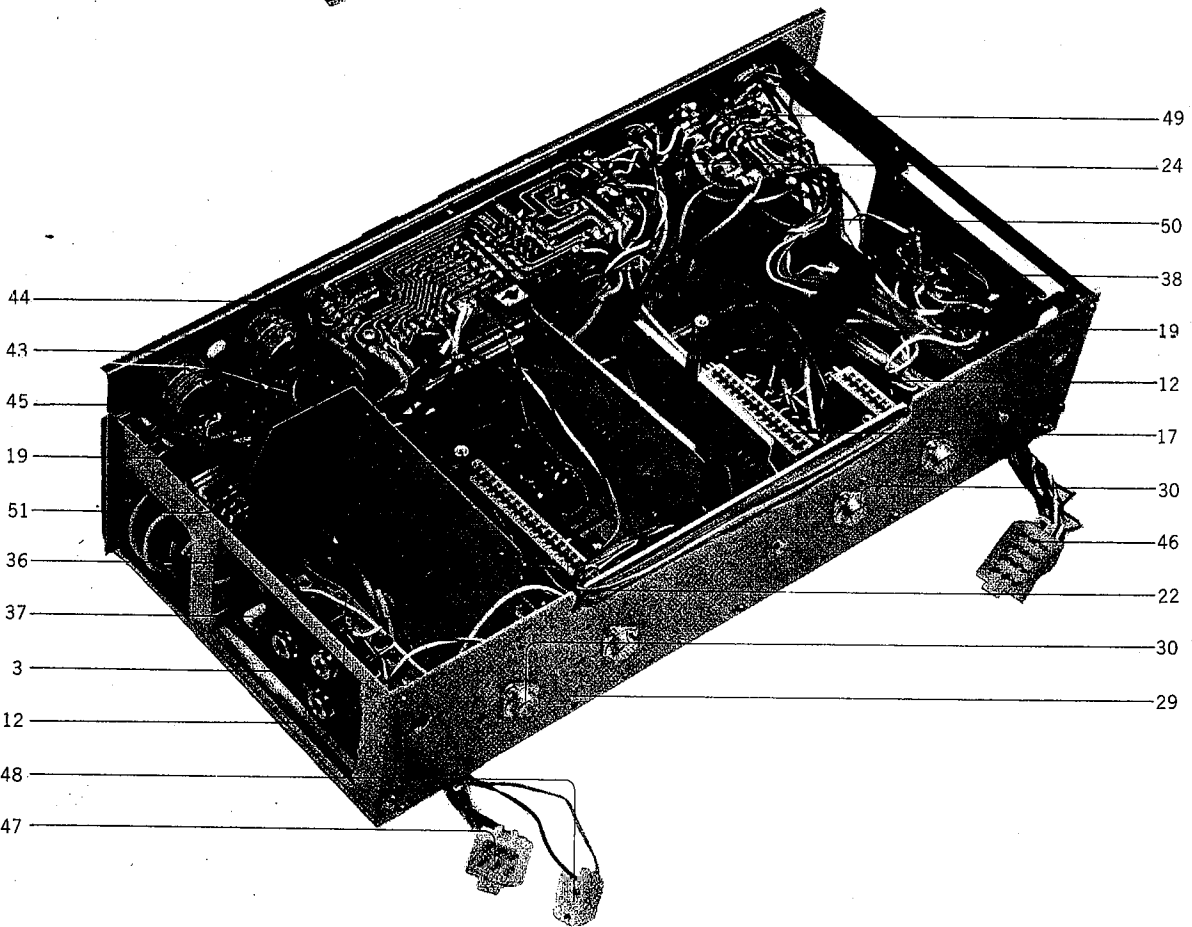
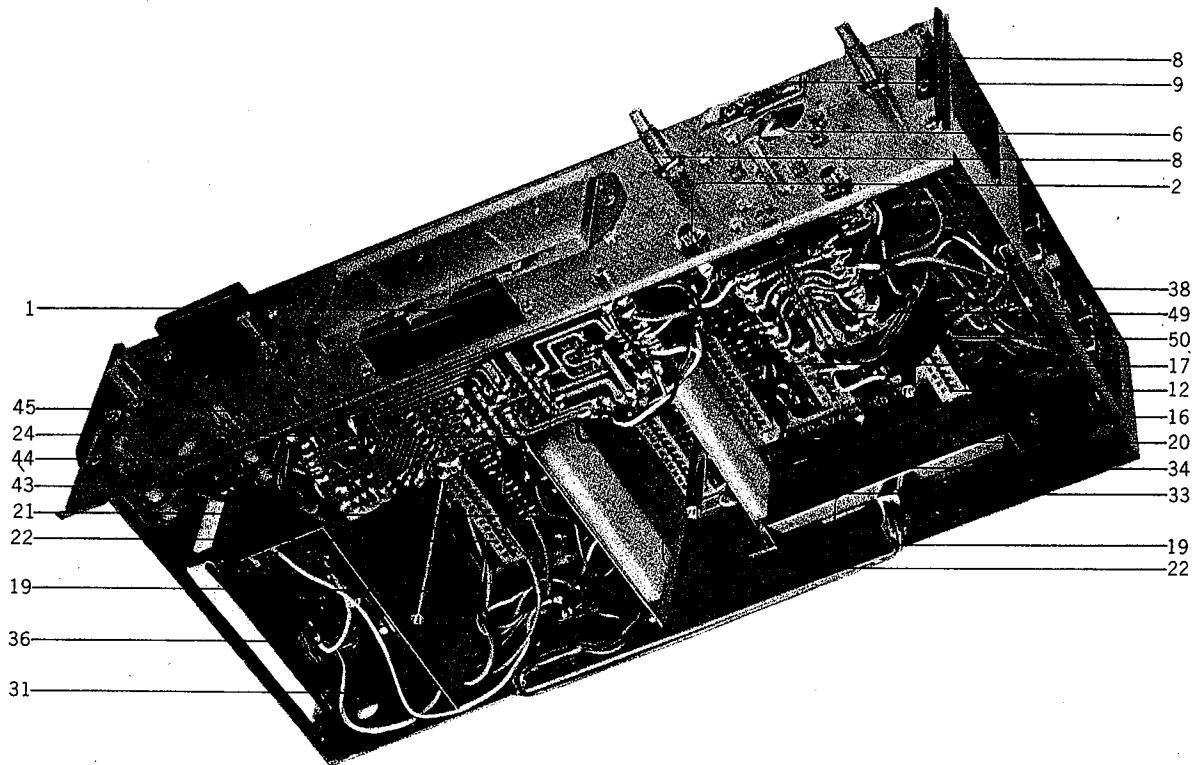



## AMPLIFIER CHASSIS BLOCK (RD-2300)

Ref. No.	Parts No.	Nomenclature	Ref. No.	Parts No.	Nomenclature
1	RD-2301	VU Meter (twin Type)	36	RD-2335	Speaker Jack Plate Assembly Complete
2	RD-2302	Mic. Jack (2-conductor "E" Type)	37	RD-2336	Speaker Switch
3	RD-2303	Headphone Jack (3-conductor "E" type)	38	RD-2337	Line Jack Plate Assembly Complete
4	RD-2304	Bracket, Recording Switch Mounting	39	RD-R3,4	Carbon Resistor 1/4 W 33K (K)
5	RD-2305	Screw, binding head 3 x 5 mm (with washer)	40	RD-R5,6	Carbon Resistor 1/4 W 150K (K)
6	RD-2306	Micro Switch (VV-15-3A) for Recording	41	RD-R7,8	Carbon Resistor 1/4 W 22K (K)
7	RD-2307	Screw, round head 3 x 15 mm (for micro switch)	42	RD-R9,10	Carbon Resistor 1/4 W 10K (K)
8	RD-2308	Mic. Volume Control with Tone (D24N 50KA/100KA)	43	RD-2338	Volume, Bass Control 50KAx2 (VR-4a)
9	RD-2309	Indicator Lamp Printed Board	44	RD-2339	Volume, Treble Control 50KA x 2
10	RD-2310	Lamp (NE-2Q)	45	RD-2340	Volume Control, left and right (VR-3)
11	RD-2311	Solid Resistor 1/4 watt 33K	46	RD-2341	12P Plug,
12	RD-2312	10P Printed Circuit Connector	47	RD-2342	6P Plug
13	RD-2313	Screw, round head 3 x 6 mm	48	RD-2343	3P Plug
14	RD-2314	Prop A, Connector Mounting	49	RD-525	C.O.M. Set Switch, Printed Circuit Assy. Comp.
15	RD-2315	Screw, binding head 3 x 5 mm	50	RD-2200	C.O.M. Volume Assy. with Micro Motor
16	RD-2316	Prop B, Printed Circuit Retaining	51	RD-523	Monitor Switch, Printed Circuit Board Assy. Comp.
17	RD-2317	14P Printed Circuit Connector			
18	RD-2318	Screw, round head 3 x 12 mm			
19	RD-2319	Prop, Printed Circuit Retaining			
20	RD-2320	Printed Circuit Board (RD-526)			
21	RD-2321	Printed Circuit Board (RD-532)			
22	RD-2322	22P Printed Circuit Connector			
23	RD-2323	Prop C, Connector Mounting			
24	RD-522	Track Selector Board			
25	RD-2324	Bucking, for Retaining Track Selector Switch			
26	RD-2325	Screw, binding head 3 x 8 mm			
27	RD-2326	Bracket, Printed Board Mounting			
28	RD-2327	Screw, binding head 3 x 5 mm			
29	RD-2328	Heat Sink Block			
30	RD-2329	Transistor 2SD-130R			
31	RD-2330	Plate, Heat Sink			
32	RD-2331	Set Screw 3 x 8 mm			
33	RD-2332	Socket, Transistor Mounting			
34	RD-2333	Transistor Cover			
35	RD-2334	Screw, binding head 3 x 8 mm			

CASE & TOP PANEL (RD-2500)

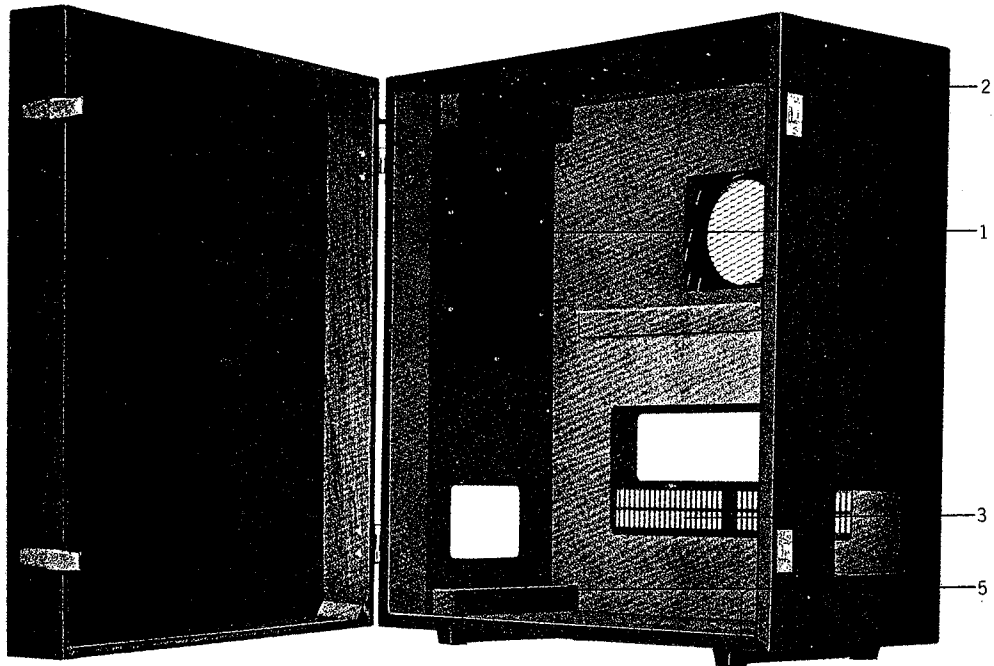

## CASE & TOP PANEL (RD-2500)

Ref. No.	Parts No.	Nomenclature	Ref. No.	Parts No.	Nomenclature
	RD-2500	Case Complete	50	K23-1	Knob, Monitor, Switch
1	RD-2501	Escutcheon, Speaker	51	K22-1	Knob, Track Selector Switch
2	RD-2502	RD Escutcheon			
3	RD-2503	Ventilator	52	RD-2018	Knob, Function Switch
4	RD-2504	Screw, truss head 3 x 6 mm			
5	RD-2505	Oblong Foot			
6	RD-2506	Screw, flat head 4 x 15 mm			
7	RD-2507	Rubber Foot			
8	RD-2508	Tapping Screw 4 x 25 mm			
9	RD-2509	Panel, Deck Cover			
10	RD-2510	Screw, truss head 3 x 6 mm			
11	RD-2511	Main Head Cover A			
12	RD-2512	Head Cover B			
13	RD-2513	Set Screw (Head Cover B)			
14	RD-2514	Knob, Brake Control			
15	RD-2515	Screw, with head 3 x 4 mm			
16	RD-2516	Knob, Shut off Switch			
17	RD-2517	Screw, without head 3 x 5 mm			
18	RD-1212	Pinch Wheel 7.5 inch			
19	RD-1213	Pinch Wheel Cap			
20	RD-2520	Pinch Wheel 15 inch			
21	RD-2521	Capstan for 15 inch			
22	RD-2522	Bracket, Tape Cleaner			
23	RD-2523	Set Screw (Minus head)			
24	RD-2524	Panel, Amplifier Cover with Meter Escutcheon			
25	RD-2525	Screw, truss head 3 x 8 mm (BNI)			
26	RD-2526	Meter Escutcheon			
27	RD-2527	Screw, oval counter sunk head 2.3 x 4 mm			
28	RD-2528	Recording Safety Escutcheon			
29	RD-2529	Knob, Line Record Level Control			
30	RD-2530	Set Screw, 4 x 7 mm			
31	RD-2531	Knob, microphone Record Level Control			
32	RD-2532	Set Screw 4 x 6.5 mm			
33	RD-2533	Knob, Volume Control			
34	RD-2534	Set Screw 4 x 6.5 mm			
35	RD-2535	Knob, Recording Safety			
36	RD-2536	Clip, Retaining			
37	RD-2537	Lever, Recording Safety Locking			
38	RD-2538	Guide Screw			
39	RD-2539	Tension Spring			
40	RD-2540	Knob, Bass Control			
41	RD-2541	Set Screw 3 x 4 mm			
42	RD-2542	Knob, Treble Control			
43	RD-1615	Reverse Set Dial			
44	RD-1618	Tape Count Meter Dial			
45	RD-1408	Supply Reel Table Complete			
46	RD-1419	Take-up Reel Table Complete			
47	RD-1747	Tape Counter Complete			
48	RD-1301	Stabilizer Shaft			
49	K39-1	Knob, Speed Selector Switch			

HEADPHONE PRINTED CIRCUIT BOARD (RD-524)

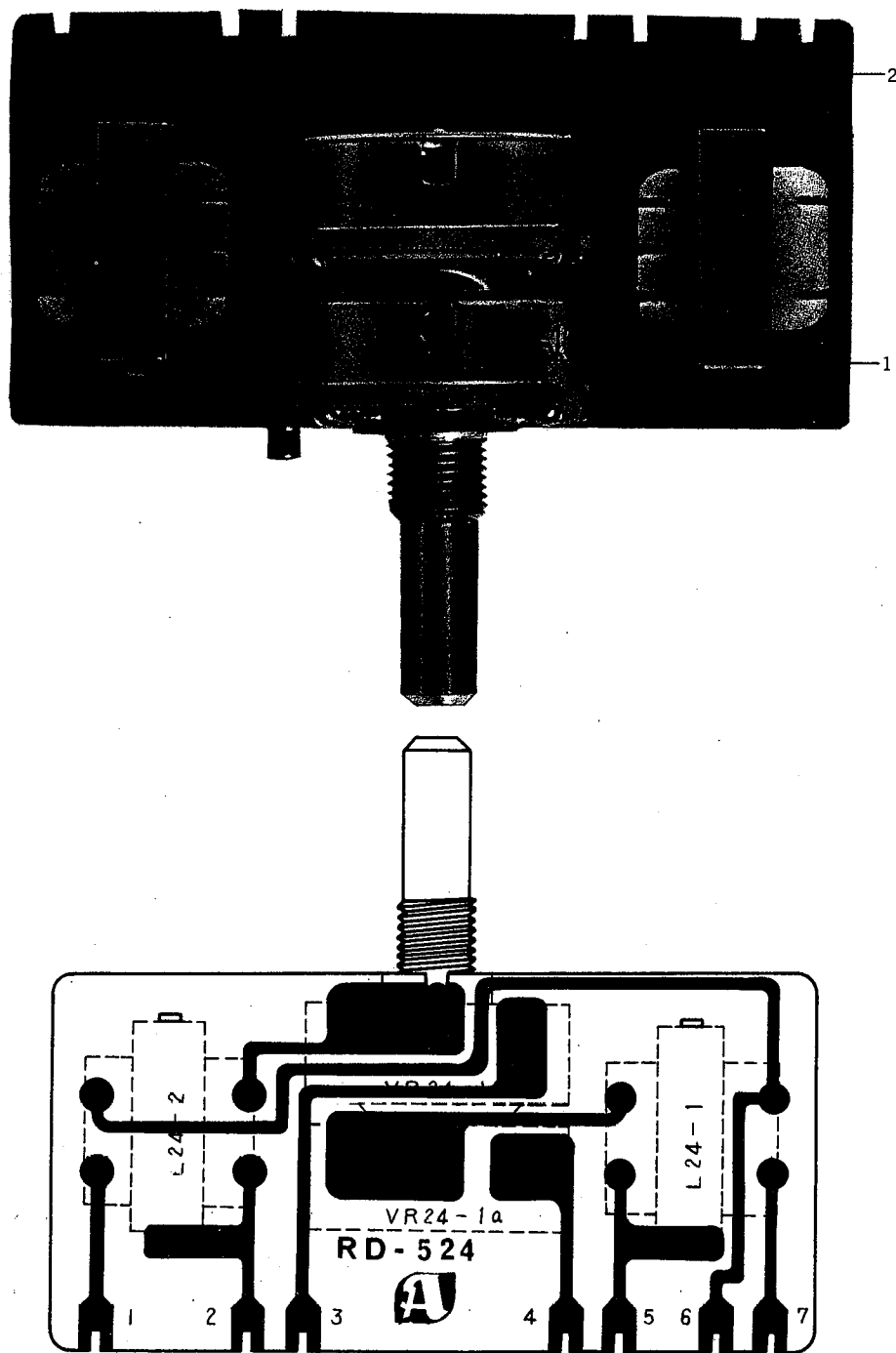

HEADPHONE PRINTED CIRCUIT BOARD (RD-524)

Ref. No.	Parts No.	Nomenclature
	RD-524	Headphone Printed Circuit Board Assembly Complete
1	VR24-1	Headphone Volume Control 10KA x 2
2	L24-1,2	Transformer, N19-5921S

### CHASSIES PRINTED BOARD (RD-526)

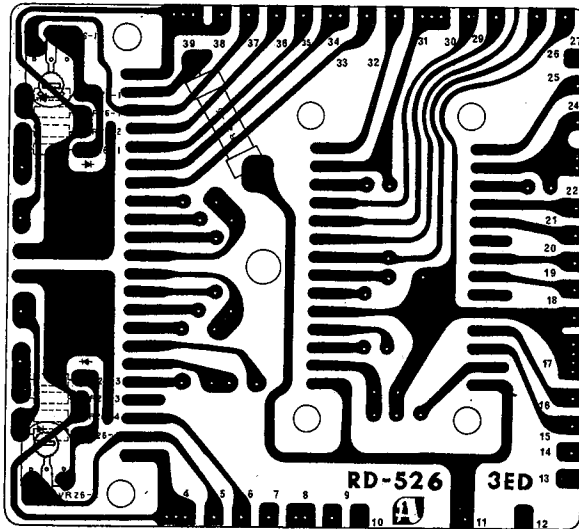

### MAIN AMPLIFIER SOCKET BOARD (RD-532)

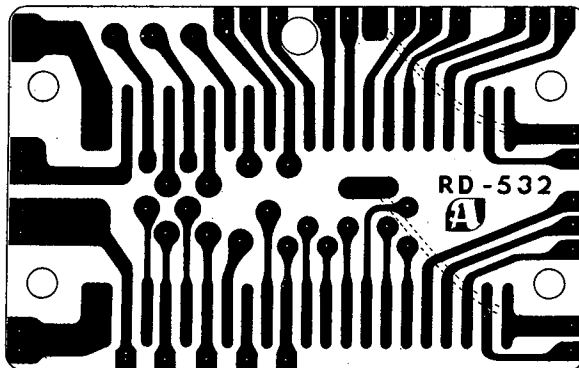

Ref. No.	Parts No.	Nomenclature
	RD-526	Chassis Printed Board Assy. Comp.
1	D26-1~4	Germanium Diode IN34A
2	R26-1~4	Solid Resistor 1/4 watt 1K (K)
3	R26-5	Solid Resistor 2 Watt 820Ω (K)
4	VR26-1,2	2KB Semi-variable Resistor
5	RD-532	Main Amplifier Socket Board

### X-360D is not provided the parts listed below:

Parts No.	Nomenclature
RD-531	Main Amplifier Printed Circuit Board Complete
RD-2328	Heat Sink Block
RD-2123	3P Socket
RD-2343	3P Plug
RD-2335	Speaker Jack Plate Assembly Complete
RD-2338	Volume, Bass Control 50KAX2 (VR-4a)
RD-2540	Knob, Bass Control
RD-2541	Set Screw 3 x 4 mm
RD-2339	Volume, Treble Control 50KA x 2
RD-2542	Knob, Treble Control
RD-2541	Set Screw 3 x 4 mm
RD-2340	Volume Control, left and right (VR-3)
RD-2533	Knob, Volume Control
RD-2534	Set Screw 4 x 6.5 mm

#### Power Source Block

RD-2104	Power Transformer (RD-T3)
RD-2121	Plate, Diode Mounting
RD-2122	Screw, binding head 3 x 5 mm
RD-2123	Silicon Diode 5B2
RD-2124	Screw, binding head 3 x 8 mm
RD-2108	Electrolytic Capacitor 1000 μ 35V
RD-2109	Electrolytic Capacitor 1000 μ 63V
RD-2110	Screw, round head 3 x 3 mm
RD-2112	Wire Wound Resistor 4W 4 Ω (J)
RD-2121	6P Socket
RD-2342	6P Plug

\*Case Complete have to be changed.

RD-2501	Escutcheon, Speaker
RD-2124	Speaker
RD-2126	Screw, binding head 3 x 12 mm
RD-2127	Lug Plate (KPL-1)
RD-2128	Wire Wound Resistor 3 W 16 Ω

### X-360D is not provided next parts listed below:

RD-524	Headphone Printed Circuit Board Assy. Comp.
VR24-1	Headphone Volume Control 10KAX2
L24-1,2	Transformer N19-5921S

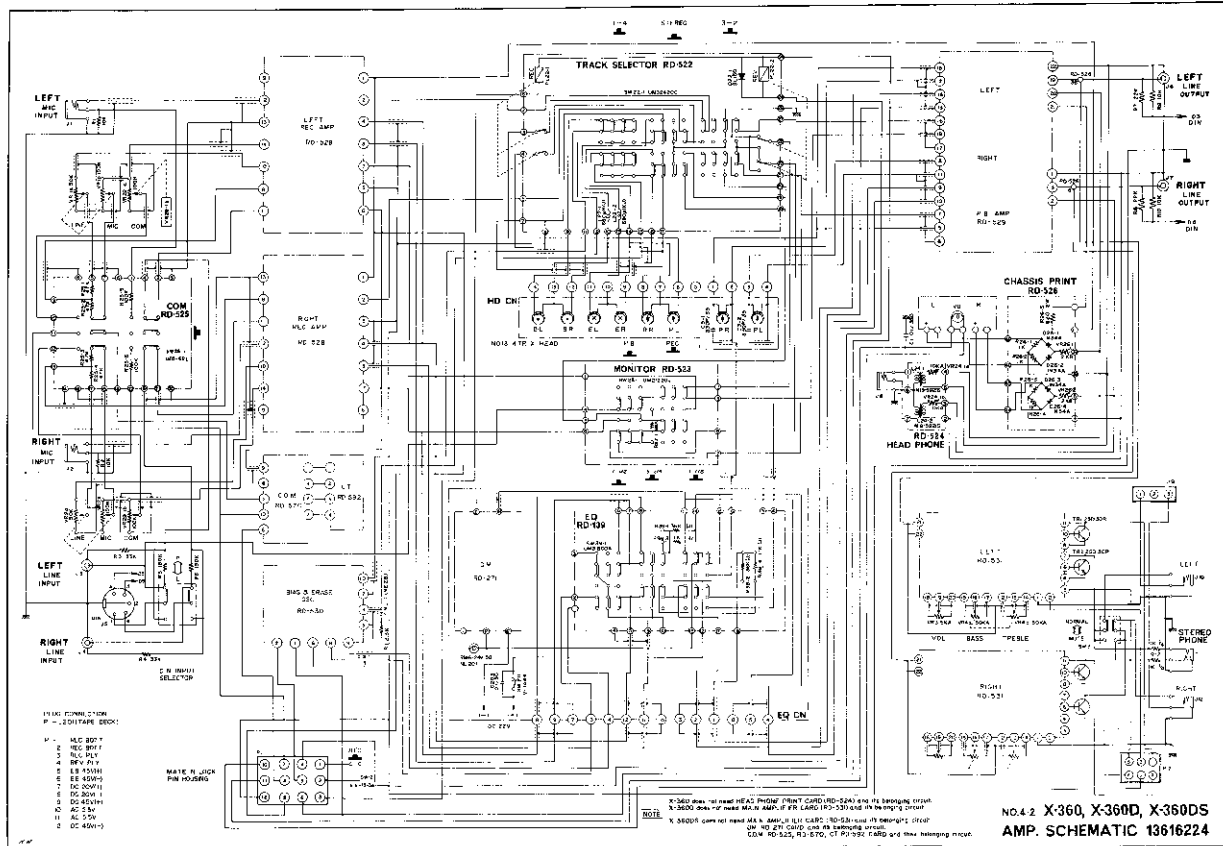

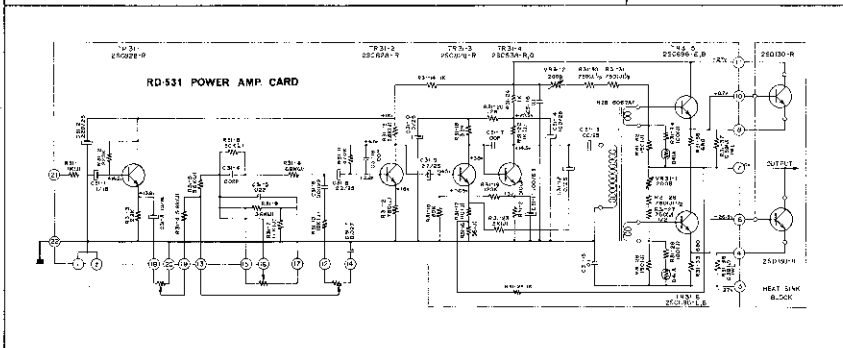
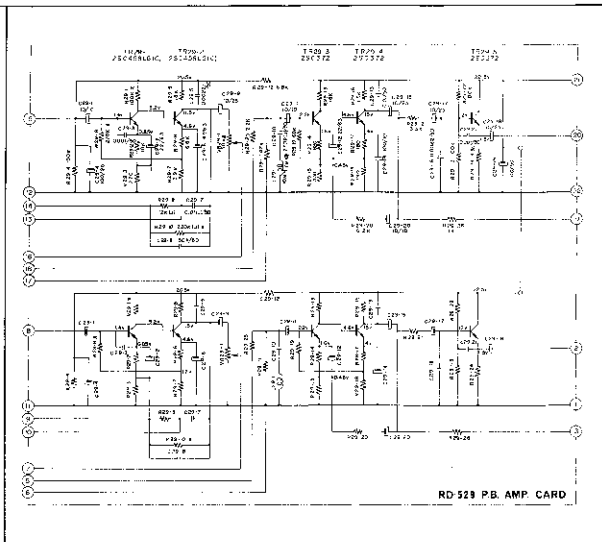
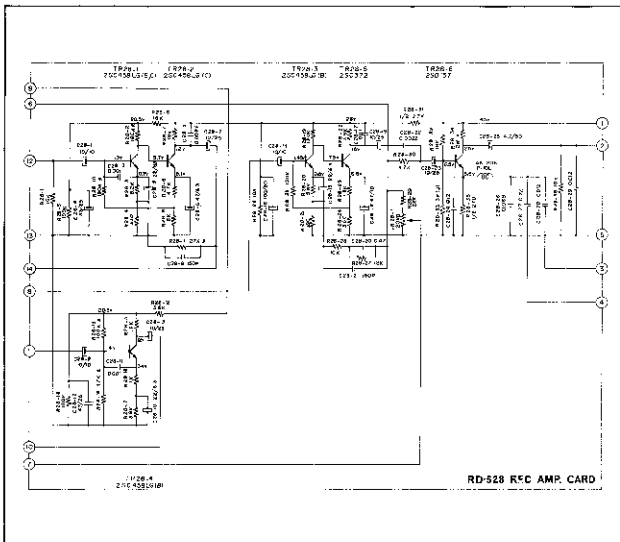

**NOTE**  
 RESISTOR  
 ..... NOISE LESS

RD-531 POWER AMP CARD IS TP 164011-1, R-164011-1, X-3600S.

**NO. 4-3 X-360, X-360D, X-360DS  
 AMP. CARD SCHEMATIC 13616164**

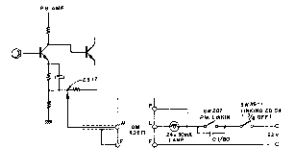
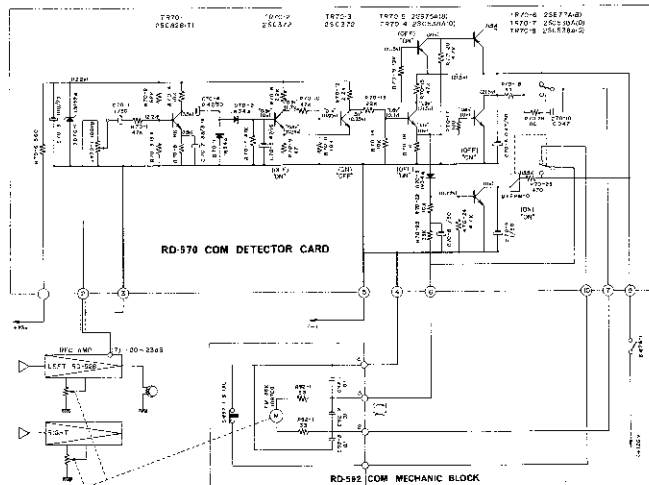
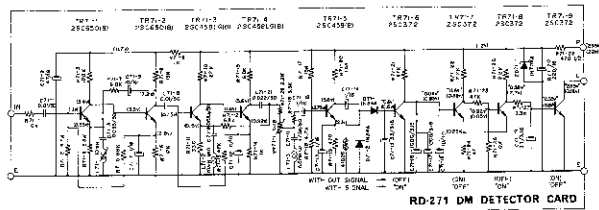
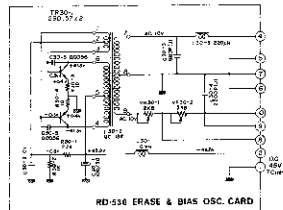

NOTE  
 1 - COMMON LEAD IN TIME  
 2 - SHIELDING LEAD IN OFF

NOTE  
 MECHANIC DETECTOR CARD AND RD-582 COM MECHANIC BLOCK IN USE SHOWN IN X-360DS.  
 RD-271 DM DETECTOR CARD IN USE SHOWN IN X-360DS.

NO. 4-4 X-360, X-360D, X-360DS  
 AMP. CARD SCHEMATIC 13616124

NOTE  
 1 - SHOWS NO. HEAT SINKING LOCATION  
 2 - SHOWS ELECTRICAL CONNECTION  
 3 - SHOWS MECHANICAL CONNECTION  
 4 - SHOWS MORE THAN ONE SIGNAL POINT



