

Service Manual

PIONEER
The future of sound and vision.

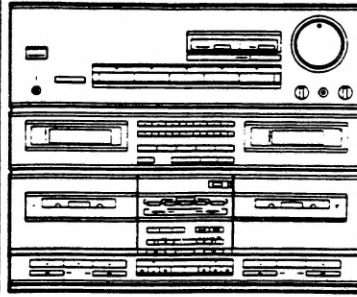

**ORDER NO.
ARP1687**

STEREO DOUBLE CASSETTE TAPE DECK AMPLIFIER

DC-Z92

MODEL DC-Z92 HAS SIX VERSIONS:

Type	Power requirement	Export destination
HB	AC220V,240V (switchcable)*	United Kingdom
HE	AC220V,240V (switchcable)*	European continent
HEZ	AC220V,240V (switchcable)*	West Germany
SD	AC110V,120V-127V,220V,240V (switchcable)	Kingdom of Saudi Arabia and general market
YP	AC240V only	Australia
KU	AC120V only	U.S.A.

*Change the jumper wires of assembly boards.

- This manual is applicable to the DC-Z92/HB, HE and SD types.
- For HE and SD types, refer to pages 81-84.
- For the other types, refer to additional service manuals.
- Ce manuel pour le service comprend les explications en français de réglage.
- Este manual de servicio trata del método ajuste escrito en español.

CONTENTS

1. SAFTY INFORMATION	2	6. ADJUSTMENTS	59
2. P.C. BOARDS LOCATION	3	RÉGLAGE	64
3. EXPLODED VIEWS, PACKING AND PARTS LIST	6	AJUSTE	69
4. SCHEMATIC DIAGRAM AND P.C. BOARDS CONNECTION DIAGRAM	18	7. IC INFORMATION	74
5. ELECTRICAL PARTS LIST	53	8. FOR HE AND SD TYPES	81
		9. CONNECTIONS	85
		10. PANEL FACILITIES	87
		11. SPECIFICATIONS	91

PIONEER ELECTRONIC CORPORATION 4-1, Meguro 1-Chome, Meguro-ku, Tokyo 153, Japan
PIONEER ELECTRONICS SERVICE INC. P.O. Box 1760, Long Beach, California 90801 U.S.A.
PIONEER ELECTRONICS OF CANADA, INC. 505 Cochrane Drive, Markham, Ontario L3R 8E3 Canada
PIONEER ELECTRONIC [EUROPE] N.V. Keetberglaan 1, 2740 Beveren, Belgium
PIONEER ELECTRONICS AUSTRALIA PTY. LTD. 178-184 Boundary Road, Braeside, Victoria 3195, Australia TEL: [03] 580-9911
© PIONEER ELECTRONIC CORPORATION 1989

YV FEB.1989 Printed in Japan.

1. SAFETY INFORMATION

1. SAFETY PRECAUTIONS

The following check should be performed for the continued protection of the customer and service technician.

LEAKAGE CURRENT CHECK

Measure leakage current to a known earth ground (water pipe, conduit, etc.) by connecting a leakage current tester such as Simpson Model 229-2 or equivalent between the earth ground and all exposed metal parts of the appliance (input/output terminals, screwheads, metal overlays, control shaft, etc.). Plug the AC line cord of the appliance directly into a 120V AC 60Hz outlet and turn the AC power switch on. Any current measured must not exceed 0.5mA.

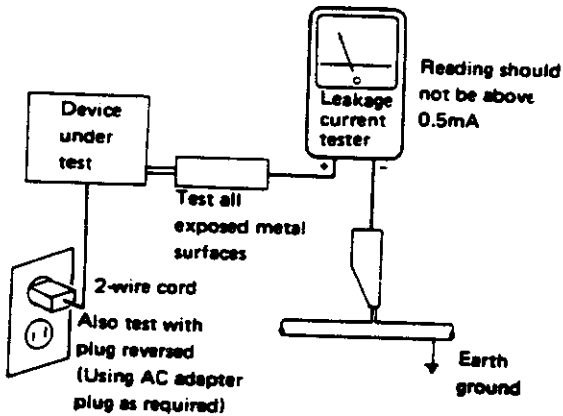

AC Leakage Test

ANY MEASUREMENTS NOT WITHIN THE LIMITS OUTLINED ABOVE ARE INDICATIVE OF A POTENTIAL SHOCK HAZARD AND MUST BE CORRECTED BEFORE RETURNING THE APPLIANCE TO THE CUSTOMER.

2. PRODUCT SAFETY NOTICE

Many electrical and mechanical parts in the appliance have special safety related characteristics. These are often not evident from visual inspection nor the protection afforded by them necessarily can be obtained by using replacement components rated for voltage, wattage, etc. Replacement parts which have these special safety characteristics are identified in this Service Manual.

Electrical components having such features are identified by marking with a Δ on the schematics and on the parts list in this Service Manual.

The use of a substitute replacement component which does not have the same safety characteristics as the PIONEER recommended replacement one, shown in the parts list in this Service Manual, may create shock, fire, or other hazards.

Product Safety is continuously under review and new instructions are issued from time to time. For the latest information, always consult the current PIONEER Service Manual. A subscription to, or additional copies of, PIONEER Service Manual may be obtained at a nominal charge from PIONEER.

2. P.C.BOARDS LOCATION

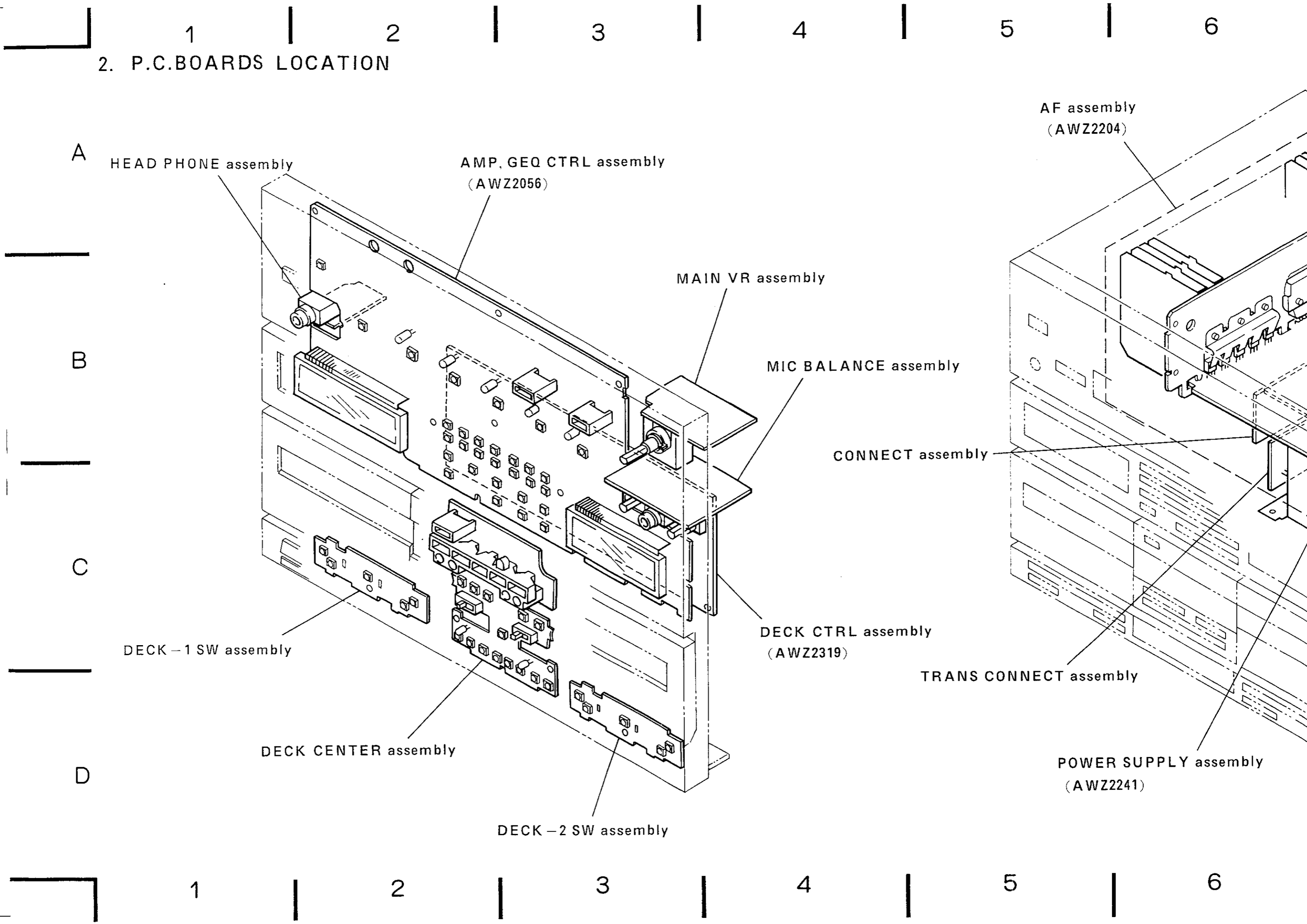

3 | 4 | 5 | 6 | 7 | 8 | 9

. assembly

A

B

C

D

MAIN VR assembly

AF assembly
(AWZ2204)

GEQ assembly
(AWG1016)

MIC BALANCE assembly

CONNECT assembly

REC assembly
(AWK1178)

FUNCTION assembly
(AWK1174)

DECK CTRL assembly
(AWZ2319)

TRANS CONNECT assembly

POWER SUPPLY assembly
(AWZ2241)

l assembly

3 | 4 | 5 | 6 | 7 | 8 | 9

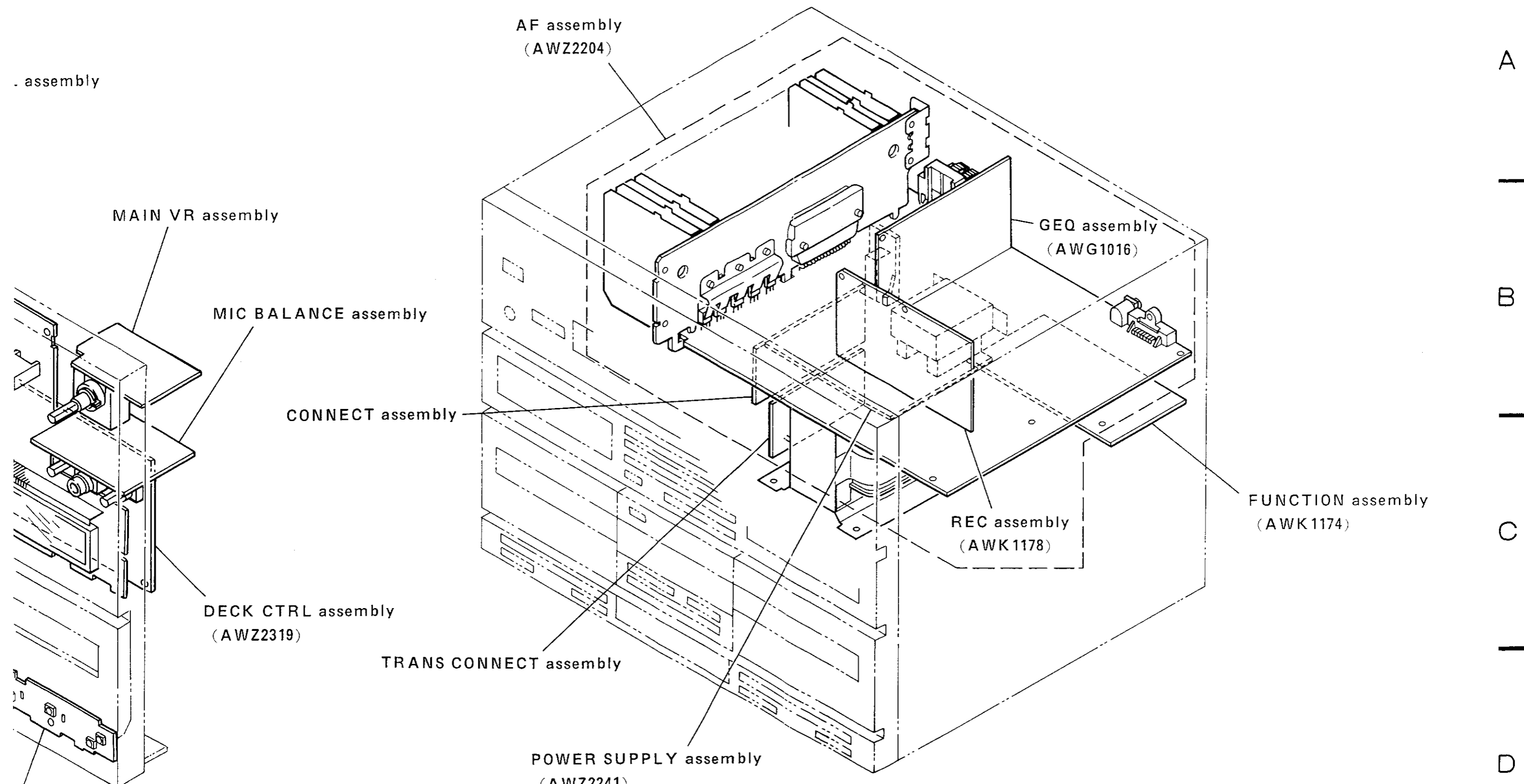

3. EXPLODED VIEWS, PACKING AND PARTS LIST

3.1 PARTS LIST OF MAIN BODY SECTION, FRONT PANEL SECTION AND PACKING

NOTES:

- Parts without part number cannot be supplied.
- The Δ mark found on some component parts indicates the importance of the safety factor of the part. Therefore, when replacing, be sure to use parts of identical designation.
- Parts marked by "●" are not always kept in stock. Their delivery time may be longer than usual or they may be unavailable.

Mark	No.	Part No.	Description	Mark	No.	Part No.	Description
	1	AWK1174	FUNCTION ASSY	53	AXD1087		REMOTE CONTROL UNIT
	2	ATS1184	POWER TRANSFORMER	54	ARM1003		CAUTION CARD
	3	AEK-509	FUSE (T1.25A)FU2004	55	AHA1234		PAD(L)
	4	AEK-509	FUSE (T1.25A)FU2005				
	5	AEK-510	FUSE (T1.6A) FU2003	56	AHA1235		PAD(R)
	6	AEK-511	FUSE (T2A)FU2001	57	AHD1584		PACKING CASE
	7	ADG-063	AC POWER CORD	58	ANE1182		BONNET
	8	AAW1007	COUNTER	59			MIC BALANCE ASSY
	9	AEC-847	LEG ASS'Y	60	AWG1016		GEQ ASSY
	10	ABF1013	WASHER (PAPER)	61			MAIN VR ASSY
	11	ABH1050	SPRING1(L)	62			HEAD PHONE ASSY
	12	ABH1051	SPRING2(R)	63			TRANS CONNECT ASSY
	13	AEB1085	COUNTER BELT	64	AWZ2204		AF ASSY
	14	AMR1656	EJECT LEVER-1 (L)	65	AWK1178		REC ASSY
	15	AMR1657	EJECT LEVER-2 (R)	66	AWZ2056		AMP. GEQ CTRL ASSY
	16	AXA1005	DAMPER ASSEMBLY	67			DECK-1 SW ASSY
	17	ABA1084	SCREW	68			DECK-2 SW ASSY
	18	ABA1085	SCREW	69	AWZ2319		DECK CTRL ASSY
	19	BBZ26P080FMC	SCREW	70			DECK CENTER ASSY
	20	BBZ30P060FMC	SCREW	71			
	21	BBZ30P080FCU	SCREW	72	AWZ2241		POWER SUPPLY ASSY
	22	BBZ30P080FZK	SCREW	73			CONNECT ASSY
	23	BPZ26P080FMC	SCREW	74			TERMINAL SCREW
	24	NK90FUC	NUT	75			EARTH LEAD
	25	VBH30P080FMC	SCREW	76			MECHA UNIT 1
	26	VBZ30P200FMC	SCREW	77			MECHA UNIT 2
	27	VPZ30P080FZK	SCREW	78			CHASSIS
	28	VTZ30P100FZK	SCREW	79			REAR PANEL
	29	AMB1439	FRONT PANEL ASSEMBLY	80			HEAT SINK
	30	AAK1629	INDICATOR LENS	81			PLATE
	31	AAK1636	DECORATIVE PLATE(D)	82			PLATE
	32	AAK1637	DECORATIVE PLATE(U)	83			PLATE A
	33	AAK1638	DECORATIVE PLATE(GEO L)	84			PLATE B
	34	AAK1639	DECORATIVE PLATE(GEO R)	85			PLATE
	35	AAK1655	DECORATIVE PLATE(DECK)	86			PLATE
	36	AAK1658	INDICATOR LENS B	87			PLATE
	37	AAK1663	DECORATIVE PLATE(DOOR L)	88			SHIELD PLATE
	38	AAK1664	DECORATIVE PLATE(DOOR R)	89			KEEP PLATE
	39	AAN1118	CASSETTE DOOR (R)	90			CUSHION
	40	AAN1119	CASSETTE DOOR (L)	91			RUBBER
	41	AAB1089	KNOB(VOLUME)	92			PCB SPACER
	42	AAB1090	KNOB	93			NYLON REVET
	43	AAD1521	BUTTON(POWER)	94			SPACER
	44	AAD1522	BUTTON(DIRECT)	95			BINDER
	45	AAD1523	BUTTON(FUNCTION)	96		
	46	AAD1524	BUTTON(GEO)	97		
	47	AAD1525	BUTTON(PLAY)	98		
	48	AAD1527	BUTTON(ASES)	99			"AAA" DRY CELL
	49	AAD1528	BUTTON(EJECT)	100			WARRANTY CARD
	50	AAD1530	BUTTON(REC)	101			SHEET
	51	AAE1103	SLIDE KNOB	102			SHEET
	52	ARB1156	OPERATING INSTRUCTIONS				

3.2 EXTERIOR

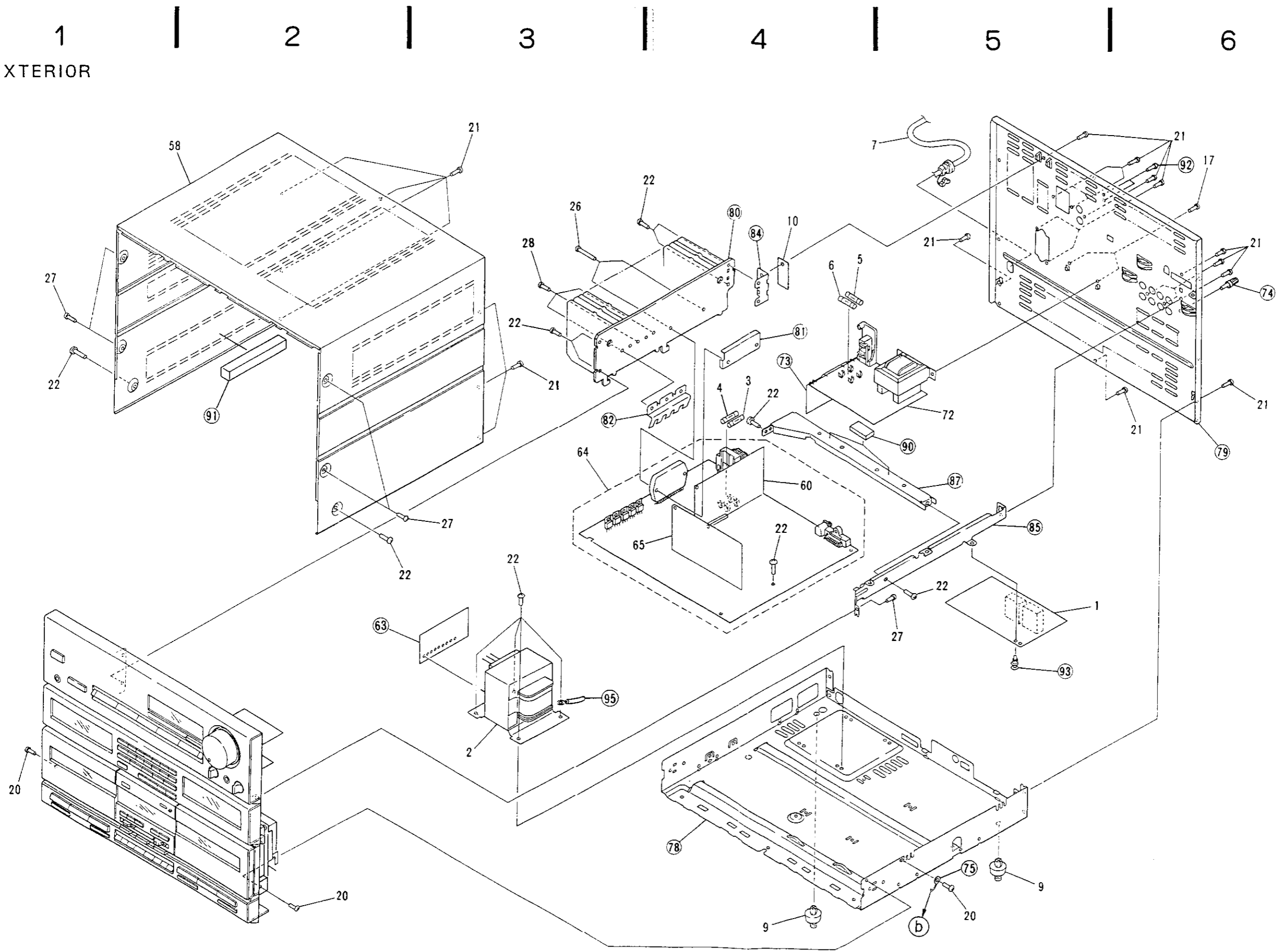

A



B



C

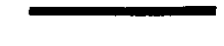

D



1

2

3

4

5

6

3.3 FRONT PANEL SECTION

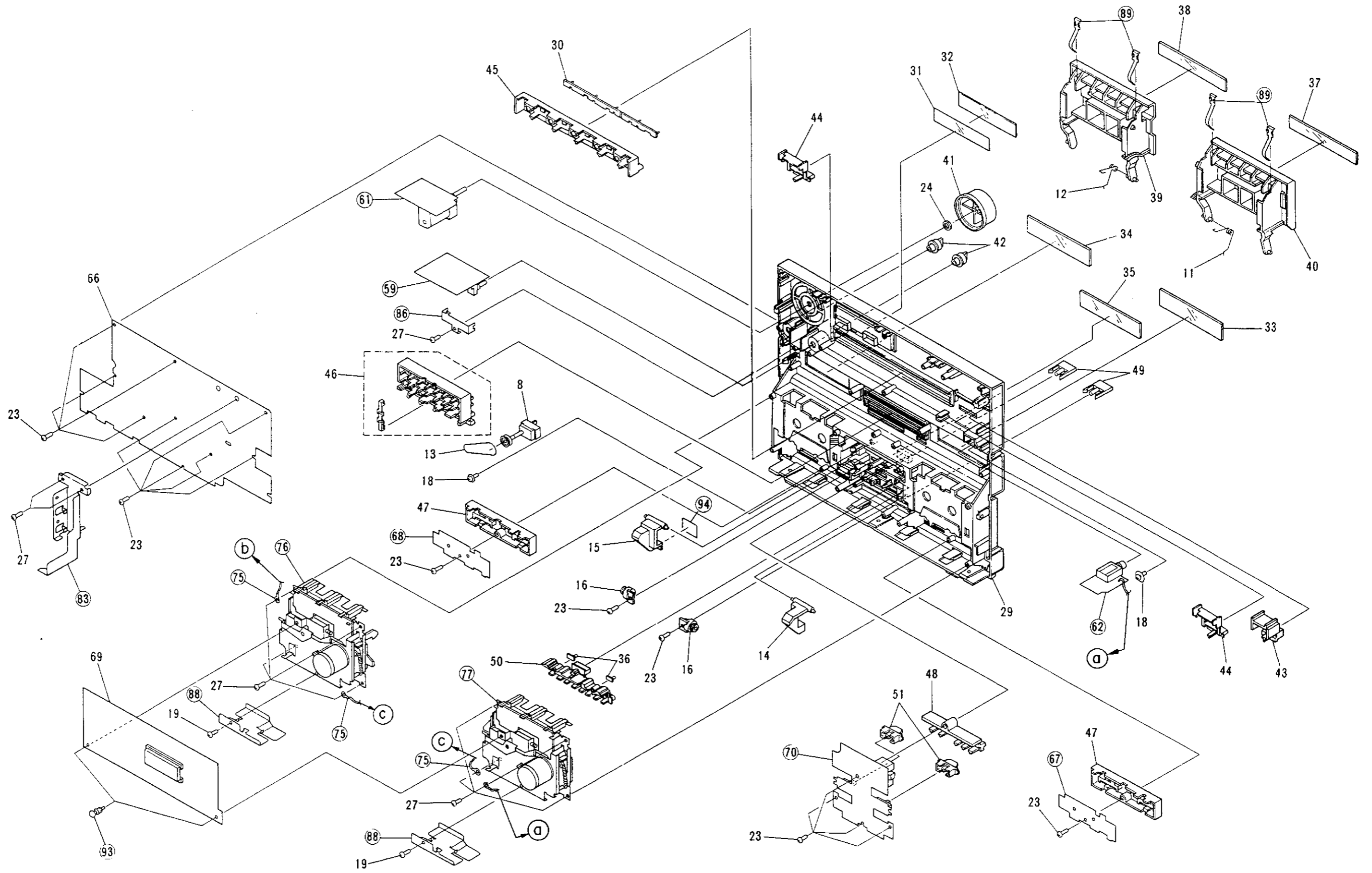

3.4 PACKING

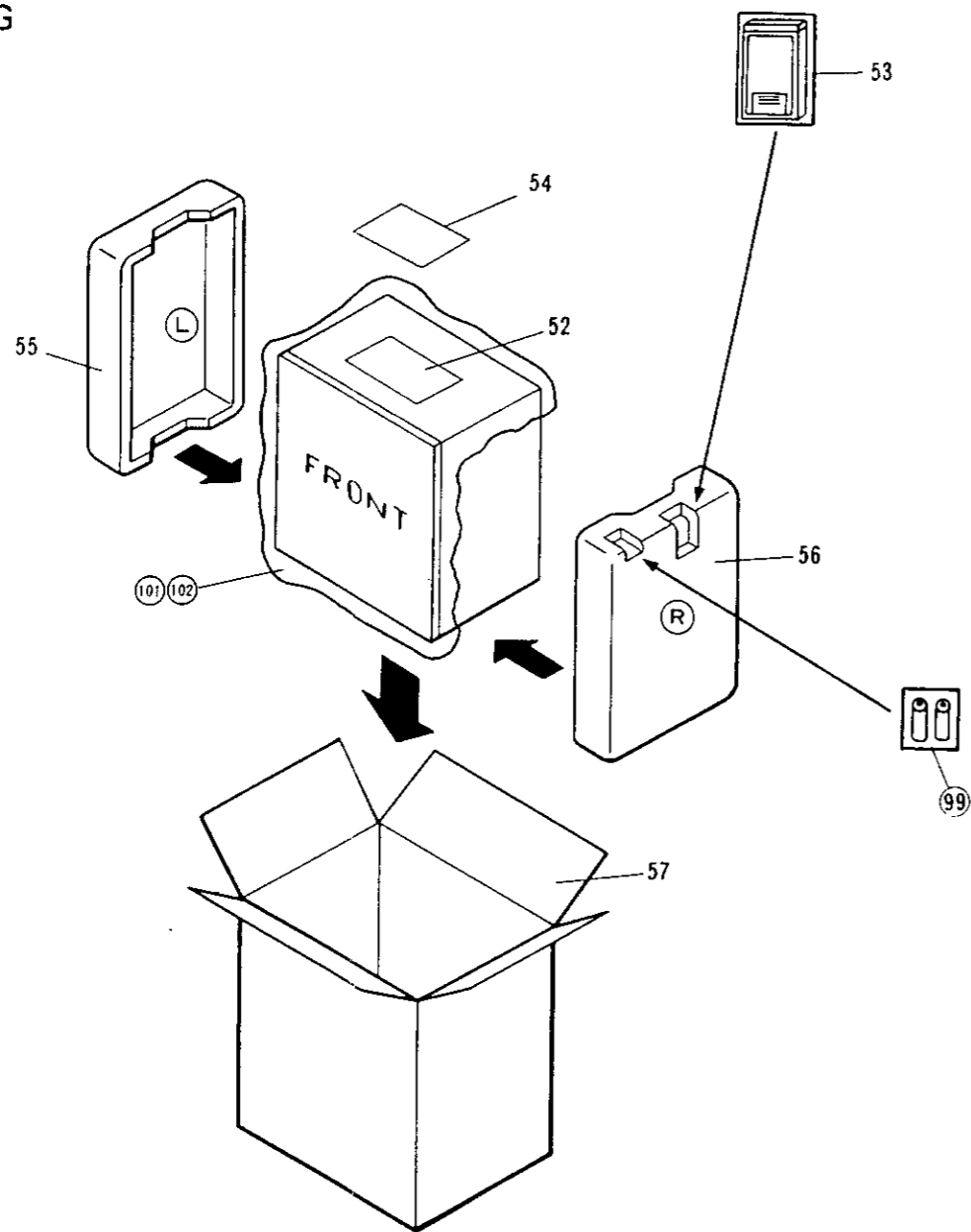

Parts list of Remote control Unit(AXD1087)

Mark	No.	Parts No.	Description
		AZN1846	Battery cover

3.5 MECHA UNIT 1

Mark	No.	Parts No.	Description	Mark	No.	Parts No.	Description
	1	AZE1018	Half IC	53	AZN1326	Head lever	
	2	AZX1019	Motor			calking assembly	
	3	AZS1054	Leaf SW(MODE)	54	AZN1327	FW assembly	
	4	AZS1034	Leaf SW	55		Head P.C.Board	
			(ARF,HALF,METAL .		HALL	EFFECT ELEMENT	
			CrO2,ARR)	56		Plate(FLYWHEEL)	
	5	AZN1286	Drive arm assembly	57	AZN1328	Azimuth plate	
				58		SW arm	
	6	AZN1287	FW assembly A	59	AZN1356	Eject arm L	
	7	AZN1288	Cam gear	60	AZN1357	Eject arm R	
	8	AZN1289	Reel			MOTOR	
	9	AZN1290	FR arm	61	AZN1330	Head arm	
	10	AZN1797	P arm L assembly	62	AZN1331	Azimuth spring	
				63	AZN1332	Cassette stopper	
	11	AZN1798	P arm R assembly	64	AZN1333	Play trigger	
	12	AZN1293	Gear			calking assembly	
	13	AZN1294	H Gear	65	AZN1334	Head frame	
	14	AZN1793	CUE arm			SOLENOID A	
	15	AZB1079	Screw	66	AZN1335	Cassette guide L	
				67	AZN1336	Cassette guide R	
	16	AZB1080	Screw	68	AZN1337	Cassette guide	
	17	AZB1296	Collar C	69	AZN1338	Cam gear	
	18	AZN1297	Motor pully	70	AZN1469	Head holder	
	19	AZN1298	Belt			SOLENOID B	
	20	AZN1299	Spring	71	AZN1340	Head gear	
				72	AZN1341	Eject arm	
	21	AZN1300	FR lever spring	73	AZN1342	Select lever	
	22	AZN1301	FWF spring	74	AZN1343	Brake	
	23	AZN1302	FWR spring	75	AZN1344	Eject lever L	
	24	AZN1303	Spring				
	25	AZB1088	Collar	76	AZN1345	Ratch lever R	
				77	AZN1346	Metal	
	26	AZN1305	Cable holder	78	AZN1347	Metal	
	27	AZN1306	Spring	79	AZN1348	Cushion	
	28	AZN1307	Spring	80	AZN1349	Trigger arm	
	29	AZN1308	Spring				
	30	AZN1309	Spring	81	AZN1350	Plunger	
				82	AZS1035	Bobbin	
	31	AZN1310	Spring	83	AZN1351	Solenoid plate	
	32	AZN1311	Spring			calking assembly	
	33	AZN1312	Spring	84	AZP1014	R/P/E Head	
	34	AZN1313	Spring	85	AZB1099	Screw	
	35	AZN1314	Spring				
				86	AZN1352	Spring	
	36	AZN1315	Spring	87	AZN1304	Spacer	
	37	AZB1081	Screw	88	AZN1470	Tube	
	38	AZN1316	Nylon band	89	AZB1100	Screw	
	39	AZN1836	P.C.Board	90	AZS1036	Bobbin	
	40		Jumper wire				
				91	AZB1101	Screw	
	41		Head lead	92	AZB1102	Spring washer	
	42		Lead wire	93		
	43		Lead wire	94	AZN1833	Capstan holder	
	44	AZN1468	Tube	95	AZN1834	Capstan holder	
	45		Mecha P.C.Board				
			calking assembly	200	AZB1084	Nut	
				201	AZB1085	E ring	
				202	AZB1086	D Screw	
	46	AZN1319	R Reel assembly				
	47	AZN1320	F Reel assembly				
	48	AZN1321	Reverse arm	203	AZB1121	P Washer	
			calking assembly	204	AZB1087	N Washer	
	49		FR lever calking assembly	205	AZB1089	U Screw	
	50	AZN1795	PLAY lever				
			calking assembly	206	AZB1090	P Washer	
	51	AZN1324	Gear arm R	207	AZB1091	Oil cut	
			calking assembly	208	AZB1092	Oil cut	
	52	AZN1325	Gear arm L	209	AZB1093	P Washer	
			calking assembly	210	AZB1094	P Washer	

1

2

3

4

5

6

Mark	No.	Parts No.	Description
	211	AZB 1095	D Screw
	212	
	213	AZB 1097	P Washer
	214	AZB 1098	M Washer
	215	AZB 1105	P Screw
	216	AZB 1106	D Screw
	217	AZB 1107	P Washer
	218	
	300	AZX 1020	Motor assembly
	301	AZP 1016	Head frame assembly
	302	AZB 1104	Screw

A

A

B

B

C

C

D

D

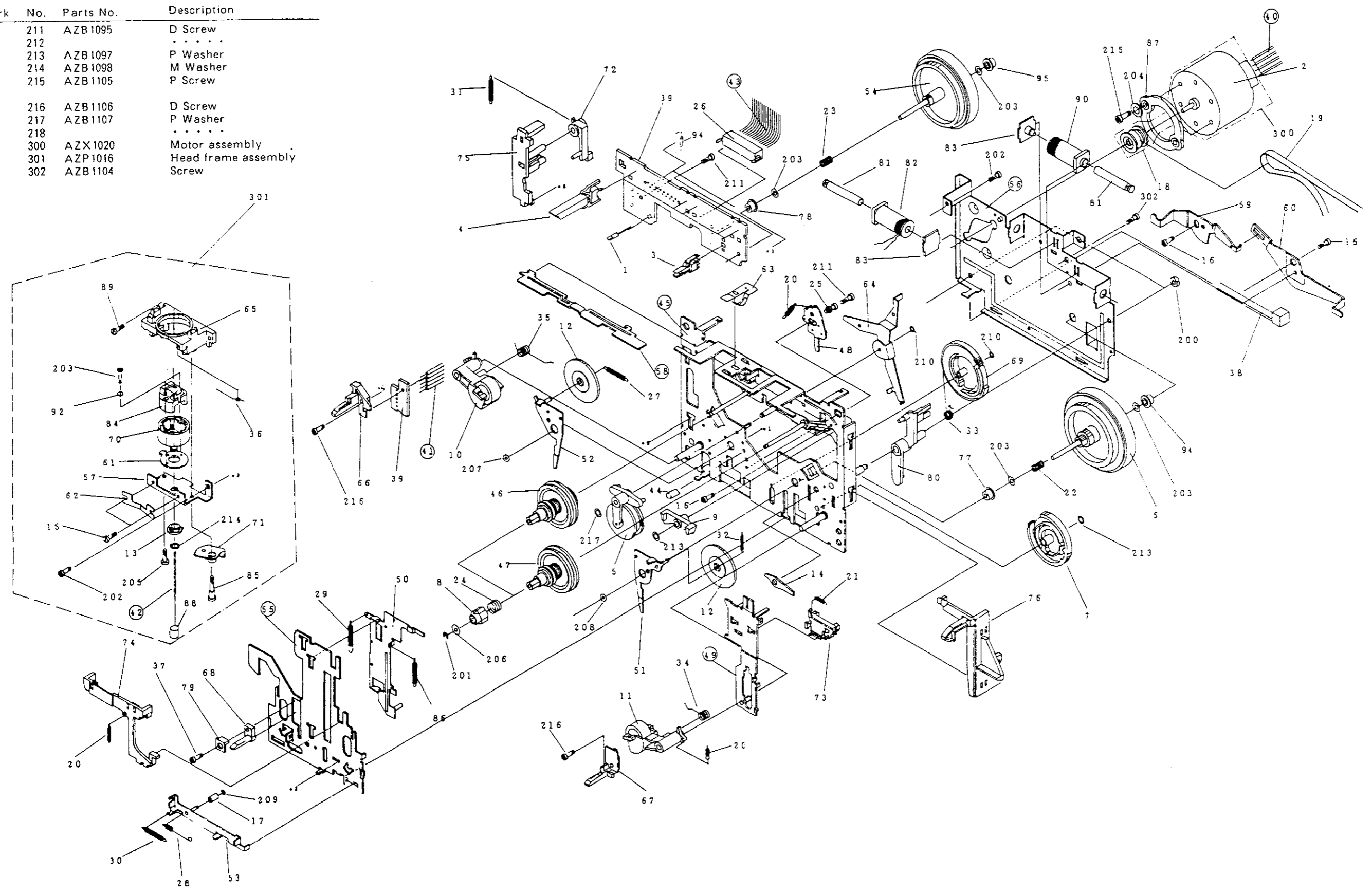

13

1

2

3

4

5

6

3.6 MECHA UNIT 2

Mark	No.	Parts No.	Description	Mark	No.	Parts No.	Description
	1	AZE1018	Hall IC	53		AZN1326	Head lever
	2	AZX1019	Motor				calking assembly
	3	AZS1054	Leaf SW(MODE)	54		AZN1327	FW assembly
	4	AZS1034	Leaf SW (ARF,HALF,METAL . CrO2,ARR)	55			Head P.C.Board
	5	AZN1286	Drive arm assembly	56			Plate(FLYWHEEL)
	6	AZN1287	FW assembly A	57		AZN1328	Azimuth plate
	7	AZN1288	Cam gear	58			SW arm
	8	AZN1289	Reel	59		
	9	AZN1290	FR arm	60		
	10	AZN1797	P arm L assembly	61		AZN1330	Head arm
	11	AZN1798	P arm R assembly	62		AZN1331	Azimuth spring
	12	AZN1293	Gear	63		AZN1332	Cassette stopper
	13	AZN1294	H Gear	64		AZN1333	Play trigger
	14	AZN1793	CUE arm				calking assembly
	15	AZB1079	Screw	65		AZN1334	Head frame
	16	AZB1080	Screw	66		AZN1335	Cassette guide L
	17	AZB1296	Collar C	67		AZN1336	Cassette guide R
	18	AZN1297	Motor pully	68		AZN1337	Cassette guide
	19	AZN1298	Belt	69		AZN1338	Cam gear
	20	AZN1299	Spring	70		AZN1469	Head holder
	21	AZN1300	FR lever spring	71		AZN1340	Head gear
	22	AZN1301	FWF spring	72		AZN1341	Eject arm
	23	AZN1302	FWR spring	73		AZN1342	Select lever
	24	AZN1303	Spring	74		AZN1343	Brake
	25	AZB1088	Collar	75		
	26	AZN1305	Cable holder	76		AZN1353	Ratch lever R
	27	AZN1306	Spring	77		AZN1346	Metal
	28	AZN1307	Spring	78		AZN1347	Metal
	29	AZN1308	Spring	79		AZN1348	Cushion
	30	AZN1309	Spring	80		AZN1349	Trigger arm
	31	AZN1310	Spring	81		AZN1350	Plunger
	32	AZN1311	Spring	82		AZS1035	Bobbin
	33	AZN1312	Spring	83		AZN1351	Solenoid plate
	34	AZN1313	Spring				calking assembly
	35	AZN1314	Spring	84		AZP1014	R/P/E Head
	36	AZN1315	Spring	85		AZB1099	Screw
	37	AZB1081	Screw	86		AZN1352	Spring
	38	AZN1316	Nylon band	87		AZN1304	Spacer
	39	AZN1836	P.C.Board	88		AZN1470	Tube
	40		Jumper wire	89		AZB1100	Screw
	41		Head lead	90		AZS1036	Bobbin
	42		Lead wire	91		AZB1101	Screw
	43		Lead wire	92		AZB1102	Spring washer
	44	AZN1468	Tube	93		
	45		Mecha P.C.Board calking assembly	94		AZN1833	Capstan holder
	46	AZN1319	R Reel assembly	95		AZN1834	Capstan holder
	47	AZN1320	F Reel assembly	200		AZB1084	Nut
	48	AZN1321	Reverse arm calking assembly	201		AZB1085	E ring
	49		FR lever calking assembly	202		AZB1086	D Screw
	50	AZN1795	PLAY lever calking assembly	203		AZB1121	P Washer
	51	AZN1324	Gear arm R calking assembly	204		AZB1087	N Washer
	52	AZN1325	Gear arm L calking assembly	205		AZB1089	U Screw
				206		AZB1090	P Washer
				207		AZB1091	Oil cut
				208		AZB1092	Oil cut
				209		AZB1093	P Washer
				210		AZB1094	P Washer

Mark	No.	Parts No.	Description	Mark
	211	AZB1095	D Screw	
	212		
	213	AZB1097	P Washer	
	214	AZB1098	M Washer	
	215	AZB1105	P Screw	
	216	AZB1106	D Screw	
	217	AZB1107	P Washer	
	218		
	300	AZX1020	Motor assembly	
	301	AZP1016	Head frame assembly	
	302	AZB1104	Screw	

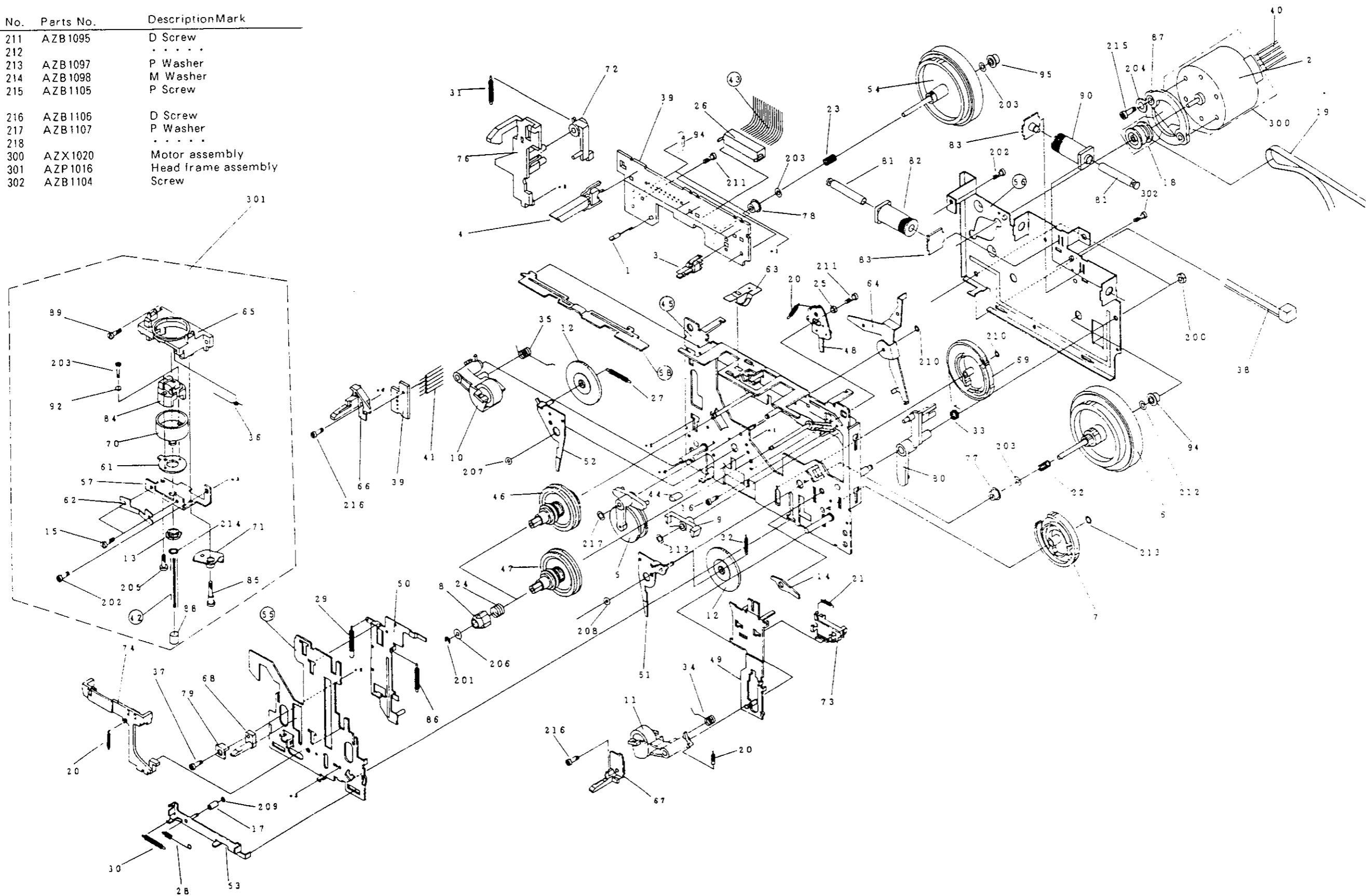

4. SCHEMATIC DIAGRAMS AND P.C.BOARD CONNECTION DIAGRAMS

4.1 OVER ALL SCHEMATIC DIAGRAM

A

B

C

D

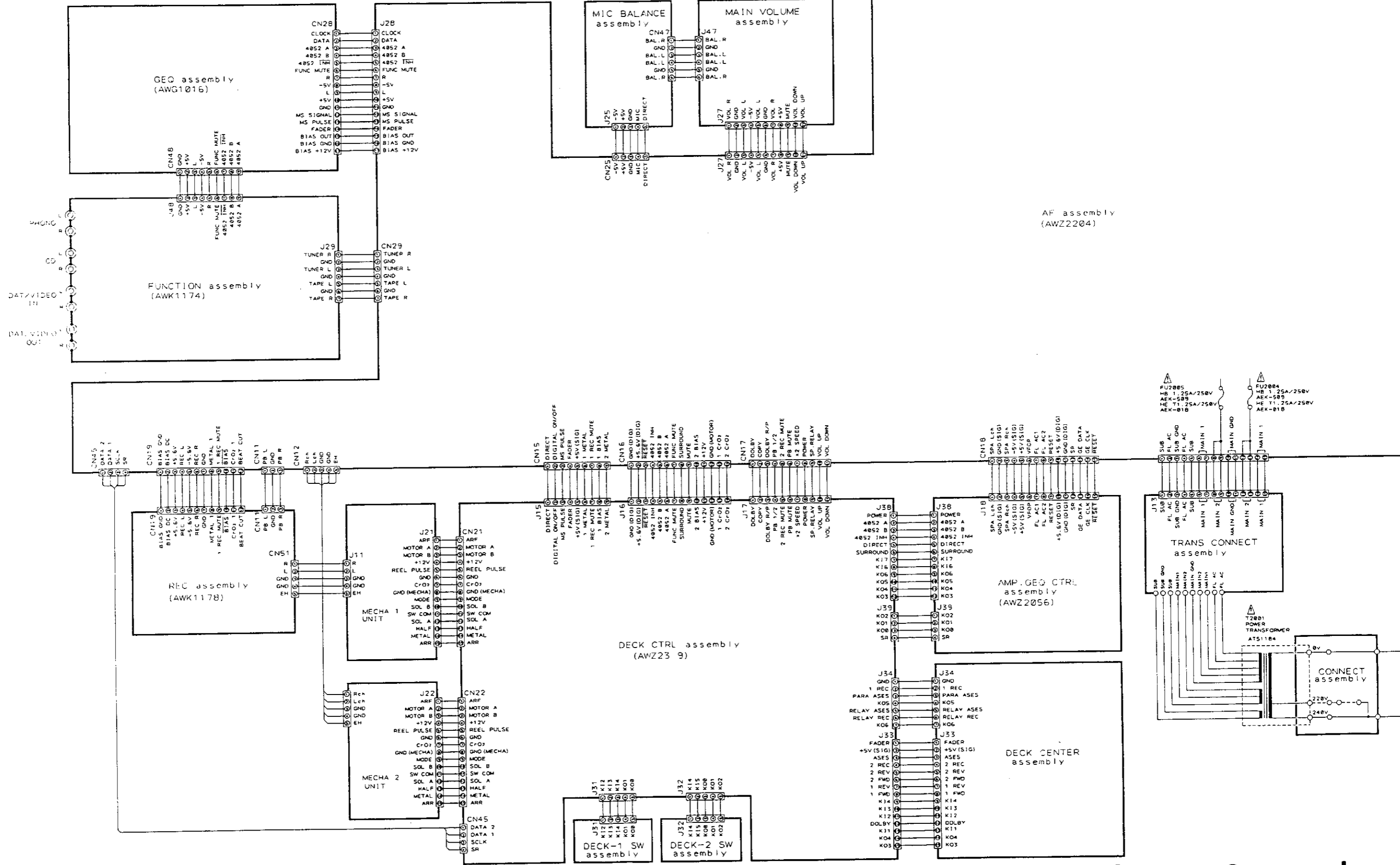

4

5

6

7

8

9

A

B

C

D

SECTION DIAGRAMS

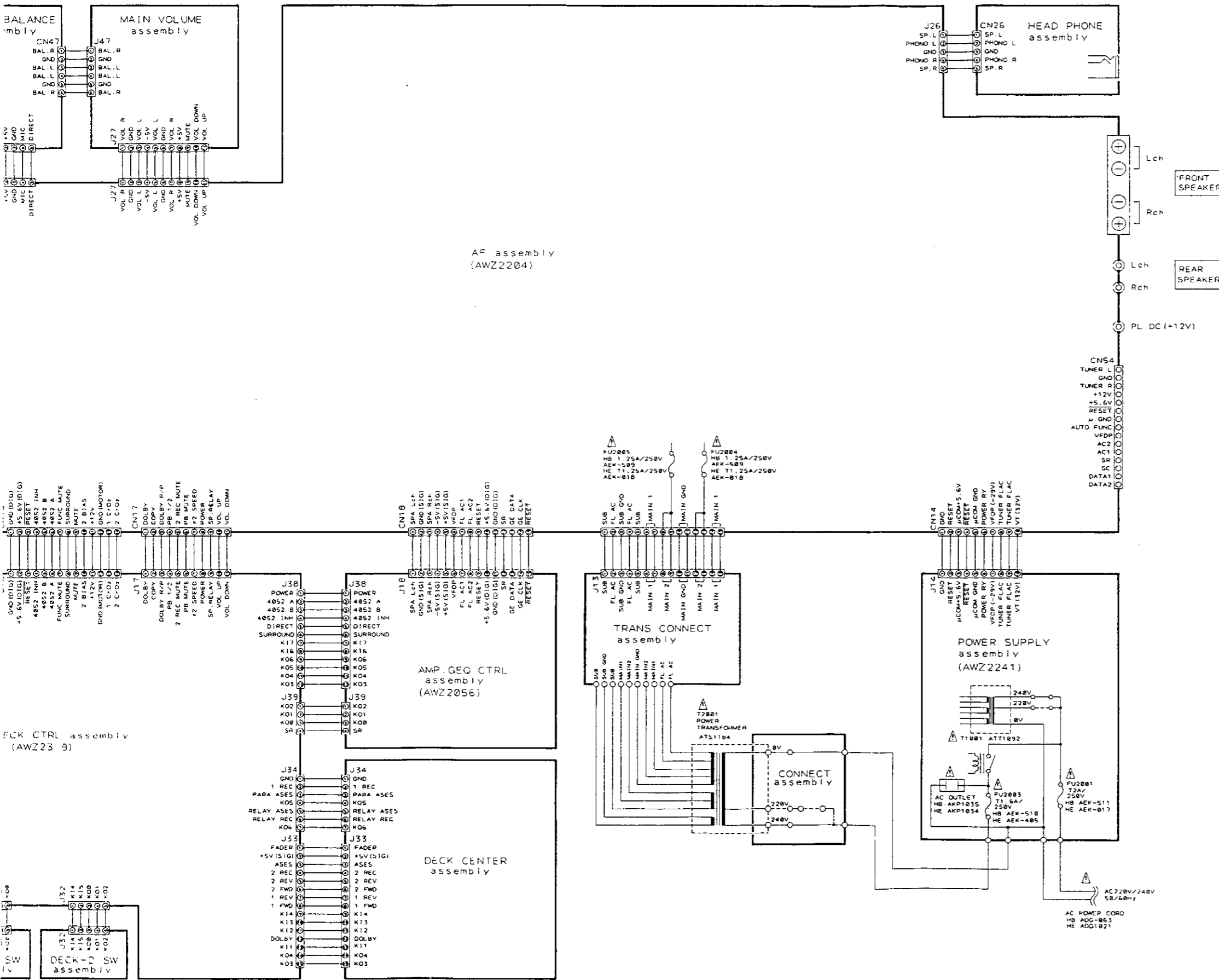

- RESISTORS:**
Indicated in Ω , $\frac{1}{2}W$, $\frac{1}{4}W$, $\frac{1}{8}W$, $\frac{1}{16}W$, $\frac{1}{32}W$, $\frac{1}{64}W$, $\frac{1}{128}W$, $\frac{1}{256}W$, $\frac{1}{512}W$, $\frac{1}{1024}W$, $\frac{1}{2048}W$, $\frac{1}{4096}W$, $\frac{1}{8192}W$, $\frac{1}{16384}W$, $\frac{1}{32768}W$, $\frac{1}{65536}W$, $\frac{1}{131072}W$, $\frac{1}{262144}W$, $\frac{1}{524288}W$, $\frac{1}{1048576}W$, $\frac{1}{2097152}W$, $\frac{1}{4194304}W$, $\frac{1}{8388608}W$, $\frac{1}{16777216}W$, $\frac{1}{33554432}W$, $\frac{1}{67108864}W$, $\frac{1}{134217728}W$, $\frac{1}{268435456}W$, $\frac{1}{536870912}W$, $\frac{1}{1073741824}W$, $\frac{1}{2147483648}W$, $\frac{1}{4294967296}W$, $\frac{1}{8589934592}W$, $\frac{1}{17179869184}W$, $\frac{1}{34359738368}W$, $\frac{1}{68719476736}W$, $\frac{1}{137438953472}W$, $\frac{1}{274877906944}W$, $\frac{1}{549755813888}W$, $\frac{1}{1099511627776}W$, $\frac{1}{2199023255552}W$, $\frac{1}{4398046511104}W$, $\frac{1}{8796093022208}W$, $\frac{1}{17592186044416}W$, $\frac{1}{35184372088832}W$, $\frac{1}{70368744177664}W$, $\frac{1}{140737488355328}W$, $\frac{1}{281474976710656}W$, $\frac{1}{562949953421312}W$, $\frac{1}{1125899906842624}W$, $\frac{1}{2251799813685248}W$, $\frac{1}{4503599627370496}W$, $\frac{1}{9007199254740992}W$, $\frac{1}{18014398509481984}W$, $\frac{1}{36028797018963968}W$, $\frac{1}{72057594037927936}W$, $\frac{1}{144115188075855872}W$, $\frac{1}{288230376151711744}W$, $\frac{1}{576460752303423488}W$, $\frac{1}{1152921504606846976}W$, $\frac{1}{2305843009213693952}W$, $\frac{1}{4611686018427387904}W$, $\frac{1}{9223372036854775808}W$, $\frac{1}{18446744073709551616}W$, $\frac{1}{36893488147419103232}W$, $\frac{1}{73786976294838206464}W$, $\frac{1}{147573952589676412928}W$, $\frac{1}{295147905179352825856}W$, $\frac{1}{590295810358705651712}W$, $\frac{1}{1180591620717411303424}W$, $\frac{1}{2361183241434822606848}W$, $\frac{1}{4722366482869645213696}W$, $\frac{1}{9444732965739290427392}W$, $\frac{1}{18889465931478580854784}W$, $\frac{1}{37778931862957161709568}W$, $\frac{1}{75557863725914323419136}W$, $\frac{1}{151115727451828646838272}W$, $\frac{1}{302231454903657293676544}W$, $\frac{1}{604462909807314587353088}W$, $\frac{1}{1208925819614629174706176}W$, $\frac{1}{2417851639229258349412352}W$, $\frac{1}{4835703278458516698824704}W$, $\frac{1}{9671406556917033397649408}W$, $\frac{1}{19342813113834066795298816}W$, $\frac{1}{38685626227668133590597632}W$, $\frac{1}{77371252455336267181195264}W$, $\frac{1}{154742504910672534362390528}W$, $\frac{1}{309485009821345068724781056}W$, $\frac{1}{618970019642690137449562112}W$, $\frac{1}{1237940039285380274899124224}W$, $\frac{1}{2475880078570760549798248448}W$, $\frac{1}{4951760157141521099596496896}W$, $\frac{1}{9903520314283042199192993792}W$, $\frac{1}{19807040628566084398385987584}W$, $\frac{1}{39614081257132168796771975168}W$, $\frac{1}{79228162514264337593543950336}W$, $\frac{1}{158456325028528675187087900672}W$, $\frac{1}{316912650057057350374175801344}W$, $\frac{1}{633825300114114700748351602688}W$, $\frac{1}{1267650600228229401496703205376}W$, $\frac{1}{2535301200456458802993406410752}W$, $\frac{1}{5070602400912917605986812821504}W$, $\frac{1}{10141204801825835211973625643008}W$, $\frac{1}{20282409603651670423947251286016}W$, $\frac{1}{40564819207303340847894502572032}W$, $\frac{1}{81129638414606681695789005144064}W$, $\frac{1}{162259276829213363391578010288128}W$, $\frac{1}{324518553658426726783156020576256}W$, $\frac{1}{649037107316853453566312041152512}W$, $\frac{1}{1298074214633706907132624082305024}W$, $\frac{1}{2596148429267413814265248164610048}W$, $\frac{1}{5192296858534827628530496329220096}W$, $\frac{1}{10384593717069655257060992658440192}W$, $\frac{1}{20769187434139310514121985316880384}W$, $\frac{1}{41538374868278621028243970633760768}W$, $\frac{1}{83076749736557242056487941267521536}W$, $\frac{1}{166153499473114484112974882535042672}W$, $\frac{1}{332306998946228968225949765070085344}W$, $\frac{1}{664613997892457936451899530140170688}W$, $\frac{1}{1329227995784915872903799060280341376}W$, $\frac{1}{2658455991569831745807598120560682752}W$, $\frac{1}{5316911983139663491615196241121365504}W$, $\frac{1}{10633823966279326983230392482242731008}W$, $\frac{1}{21267647932558653966460784964485462016}W$, $\frac{1}{42535295865117307932921569928970924032}W$, $\frac{1}{85070591730234615865843139857941848064}W$, $\frac{1}{170141183460469231731687279715883696128}W$, $\frac{1}{340282366920938463463374559431767392256}W$, $\frac{1}{680564733841876926926749118863534784512}W$, $\frac{1}{1361129467683753853853498237727069569024}W$, $\frac{1}{27222589353675077077069964754541391384}W$, $\frac{1}{5444517870735015415413992950908272768}W$, $\frac{1}{10889035741470030830827985901816545536}W$, $\frac{1}{21778071482940061661655971803633091072}W$, $\frac{1}{43556142965880123323311943607266182144}W$, $\frac{1}{87112285931760246646623887214532364288}W$, $\frac{1}{17422457186352049329324777442906472576}W$, $\frac{1}{34844914372704098658649554885812945152}W$, $\frac{1}{69689828745408197317299109771625890304}W$, $\frac{1}{13937965749081639463459821954325178068}W$, $\frac{1}{278759314981632789269196439086503561376}W$, $\frac{1}{557518629963265578538392878173007122752}W$, $\frac{1}{111503725992653115707678575634601425504}W$, $\frac{1}{2230074519853062314153571512692028510016}W$, $\frac{1}{446014903970612462830714302538405702032}W$, $\frac{1}{89202980794122492566142860507681140464}W$, $\frac{1}{178405961588244985132285721015362280928}W$, $\frac{1}{356811923176489970264571442030724561856}W$, $\frac{1}{713623846352979940529142884061449133712}W$, $\frac{1}{1427247692705959881058285768122898267424}W$, $\frac{1}{2854495385411919762116571536245796534848}W$, $\frac{1}{570899077082383952423314307249159306976}W$, $\frac{1}{1141798154164767904846628614493186133952}W$, $\frac{1}{2283596308329535809693257228986372267904}W$, $\frac{1}{4567192616659071619386514457972744535808}W$, $\frac{1}{9134385233318143238773028915945489071616}W$, $\frac{1}{182687704666362864775460578318909781332}W$, $\frac{1}{36537540933272572955092115663781956264}W$, $\frac{1}{73075081866545145910184231327563912528}W$, $\frac{1}{146150163733090291820368462655127825056}W$, $\frac{1}{292300327466180583640736925310255650112}W$, $\frac{1}{584600654932361167281473850620511300224}W$, $\frac{1}{1169201309864722334562947701241022600448}W$, $\frac{1}{2338402619729444669125895402482045200896}W$, $\frac{1}{4676805239458889338251790804964090401792}W$, $\frac{1}{9353610478917778676503581609928180803584}W$, $\frac{1}{18707220957835557353007163219856361607168}W$, $\frac{1}{37414441915671114706014326439712723214336}W$, $\frac{1}{7482888383134222941202865287942544642872}W$, $\frac{1}{14965776766268445882405730575885089365744}W$, $\frac{1}{2993155353253689176481146115177017811488}W$, $\frac{1}{5986310706507378352962292230354035622976}W$, $\frac{1}{11972621413014756705924584460708071245952}W$, $\frac{1}{23945242826029513411849168921416142491904}W$, $\frac{1}{47890485652059026823698337842832284983808}W$, $\frac{1}{9578097130411805364739667568566456977616}W$, $\frac{1}{19156194260823610729479335371132913955232}W$, $\frac{1}{38312388521647221458958670742265827910464}W$, $\frac{1}{76624777043294442917917341484531655820928}W$, $\frac{1}{153249554086588885835834682969063211641952}W$, $\frac{1}{30649910817317777167166936593812642328384}W$, $\frac{1}{61299821634635554334333873187625284656768}W$, $\frac{1}{122599643269271108668667743575250573113536}W$, $\frac{1}{245199286538542217337335487150501146267104}W$, $\frac{1}{490398573077084434674670974301002292534208}W$, $\frac{1}{98079714615416886934934194860200458506848}W$, $\frac{1}{196159429228833773869868389720400917013696}W$, $\frac{1}{39231885845766754773973677944080183627392}W$, $\frac{1}{78463771691533509547947355888160367254784}W$, $\frac{1}{156927543383067019095894711776320734509568}W$, $\frac{1}{31385508676613403819178942355264149019136}W$, $\frac{1}{62771017353226807638357884710528298038272}W$, $\frac{1}{125542034706453615276715769421056580764544}W$, $\frac{1}{251084069412907230553431538842112116129088}W$, $\frac{1}{502168138825814461106863077684224232258176}W$, $\frac{1}{1004336277651628922213726155368448464516352}W$, $\frac{1}{2008672555303257844427452310736896929032672}W$, $\frac{1}{401734511060651568885490462147379385806544}W$, $\frac{1}{803469022121303137771080924294758771613088}W$, $\frac{1}{160693804424260627554216184858951754262176}W$, $\frac{1}{321387608848521255108432369717903508524352}W$, $\frac{1}{642775217697042510216864739435807017048704}W$, $\frac{1}{1285550435394085020433729478871614034177408}W$, $\frac{1}{2571100870788170040867458957743228068354816}W$, $\frac{1}{51422017415763400817349179154864561367092}W$, $\frac{1}{102844034831526801634698358309729127341184}W$, $\frac{1}{205688069663053603269396716619458254682368}W$, $\frac{1}{411376139326107206538793433238916509367136}W$, $\frac{1}{822752278652214413077586866477833018734272}W$, $\frac{1}{1645504577304428826155173732955660374468544}W$, $\frac{1}{3291009154608857652310347465911320748937088}W$, $\frac{1}{6582018309217715304620694931822641497874176}W$, $\frac{1}{1316403661843543060924138986364528299574832}W$, $\frac{1}{2632807323687086121848277972729056599149664}W$, $\frac{1}{5265614647374172243696555945458113198299328}W$, $\frac{1}{1053122929474834448739311189091622639659856}W$, $\frac{1}{2106245858949668897478622378183245279319712}W$, $\frac{1}{4212491717899337794957244756366490558639424}W$, $\frac{1}{8424983435798675589914489512732981117278848}W$, $\frac{1}{1684996687159735117982897902546596223455776}W$, $\frac{1}{3369993374319470235965795805093192446911552}W$, $\frac{1}{6739986748638940471931591610186384893823104}W$, $\frac{1}{1347997349727788094386318322037276988764608}W$, $\frac{1}{2695994699455576188772636644074553977537216}W$, $\frac{1}{5391989398911152377545273288149107555074432}W$, $\frac{1}{1078397879782230475509054657629821510014864}W$, $\frac{1}{215679575956446095101810931525964302002928}W$, $\frac{1}{431359151912892190203621863051928604005856}W$, $\frac{1}{862718303825784380407243726103857208011712}W$, $\frac{1}{1725436607651568760814487452207714416224224}W$, $\frac{1}{345087321530313752162897490441542884324448}W$, $\frac{1}{690174643060627504325794980883085686488976}W$, $\frac{1}{138034928612125500865158996176617137297792}W$, $\frac{1}{276069857224251001730317992353234274595584}W$, $\frac{1}{552139714448502003460635984706468549191168}W$, $\frac{1}{1104279428897004006921271969412937093822336}W$, $\frac{1}{2208558857794008013842543938825874187644672}W$, $\frac{1}{441711771558801602768508787765174837528944}W$, $\frac{1}{883423543117603205537017575530349675157888}W$, $\frac{1}{1766847086235206411074035151060699302315776}W$, $\frac{1}{3533694172470412822148070302121398604631552}W$, $\frac{1}{706738834494082564429614060424279720926304}W$, $\frac{1}{1413477668988165128859228120848559441852608}W$, $\frac{1}{282695533797633025771845624169111890552512}W$, $\frac{1}{565391067595266051543691248338223781105024}W$, $\frac{1}{1130782135190532103087382496676447562210048}W$, $\frac{1}{2261564270381064206174764993352895124420176}W$, $\frac{1}{4523128540762128412349529966705790248841312}W$, $\frac{1}{9046257081524256824699059933411580497682624}W$, $\frac{1}{1809251416304851364939811986682316099536512}W$, $\frac{1}{3618502832609702729879623973364632199073024}W$, $\frac{1}{7237005665219405459759247946729264398146048}W$, $\frac{1}{1447401133043881091951849489345852879629216}W$, $\frac{1}{2894802266087762183903698978691705759258432}W$, $\frac{1}{5789604532175524367807397957383411518516672}W$, $\frac{1}{1157920906435104873561479591476682303703344}W$, $\frac{1}{2315841812870209747122959182953364607406688}W$, $\frac{1}{463168362574041949424591836590672921481376}W$, $\frac{1}{926336725148083898849183673181345842962752}W$, $\frac{1}{185267345029616779769836734636269168592544}W$, $\frac{1}{370534690059233559539673469272538337185088}W$, $\frac{1}{741069380118467119079346938545076674370176}W$, $\frac{1}{1482138760376934378158693877090153348740352}W$, $\frac{1}{2964277520753868756317387754180306697480704}W$, $\frac{1}{5928555041507737512634775508360613349601408}W$, $\frac{1}{11857110083015475025269551016721226699202816}W$, $\frac{1}{23714220166030950050539102033442453398405632}W$, $\frac{1}{47428440332061900101078204066884906796811264}W$, $\frac{1}{94856880664123800202156408133769813593622528}W$, $\frac{1}{18971376132824760040431281626753962718724512}W$, $\frac{1}{37942752265649520080862563253507925437449024}W$, $\frac{1}{7588550$

15

11

10

9

8

7

A

B

C

D

CN12 To bare 43
 CN12 To bare 44
 CN12 To bare 44
 CN12 To bare 44

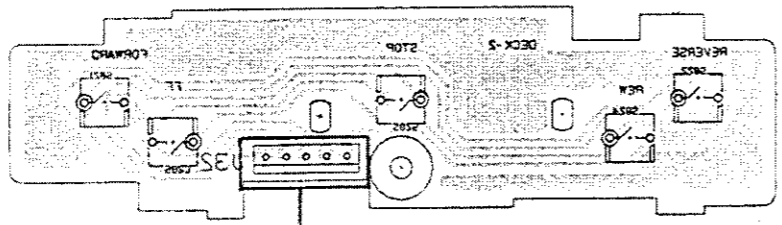

DECK CTRL assembly (AW3319)
 DECK-5 SW assembly

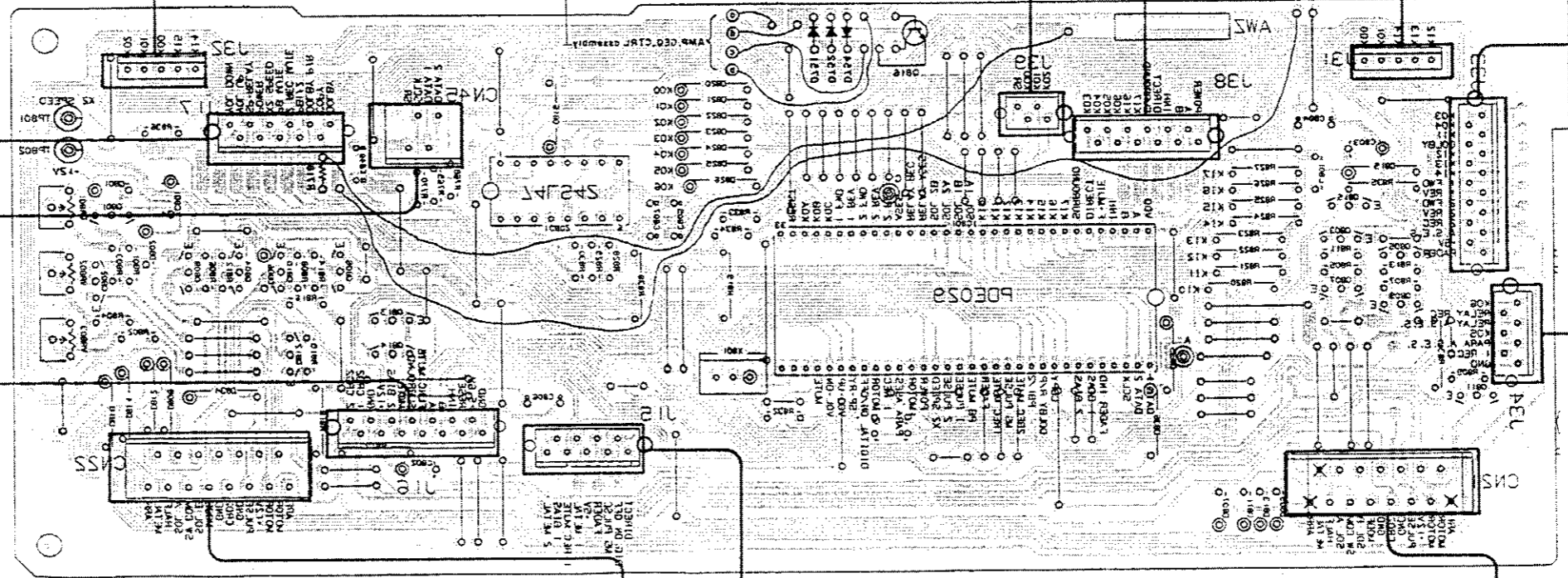

AR801-AR803 0815-0814 080E 0810 0804 0808 0801 0805
 IC805
 IC801
 0811 0803 0812 0803 0804

To bare 43
 CN12
 TO AF assembly

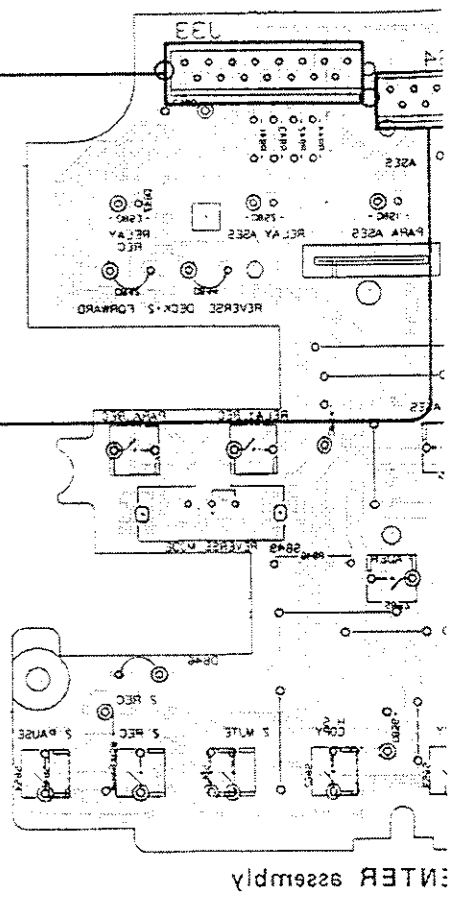
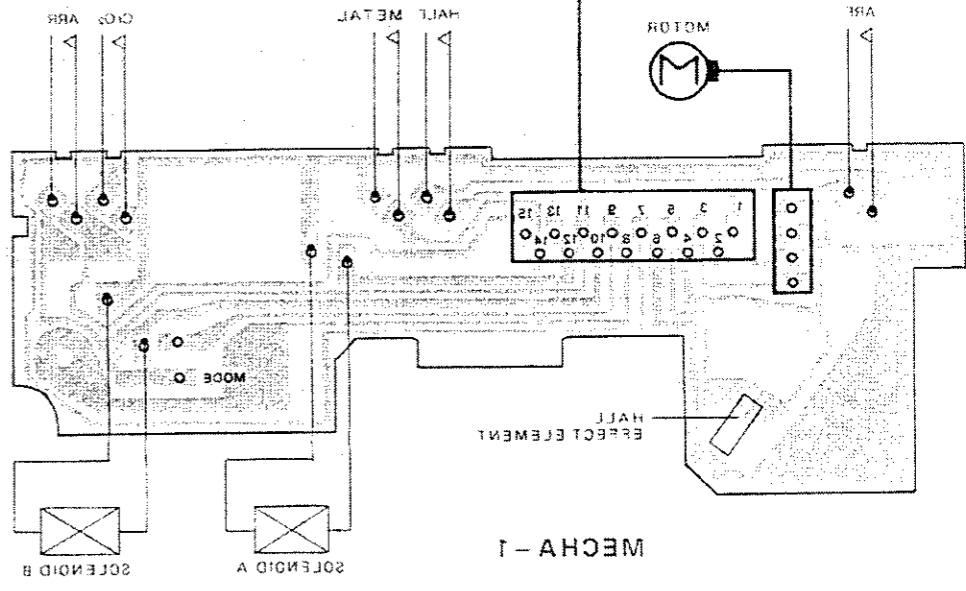
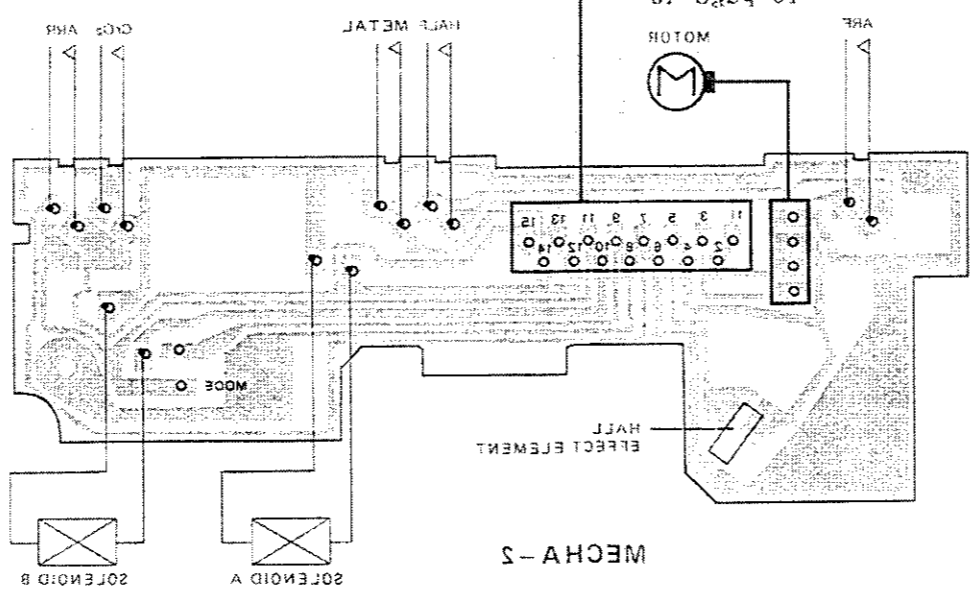

15

11

10

9

8

7

NOTE:
This picture shows the foil side of the printed circuit.

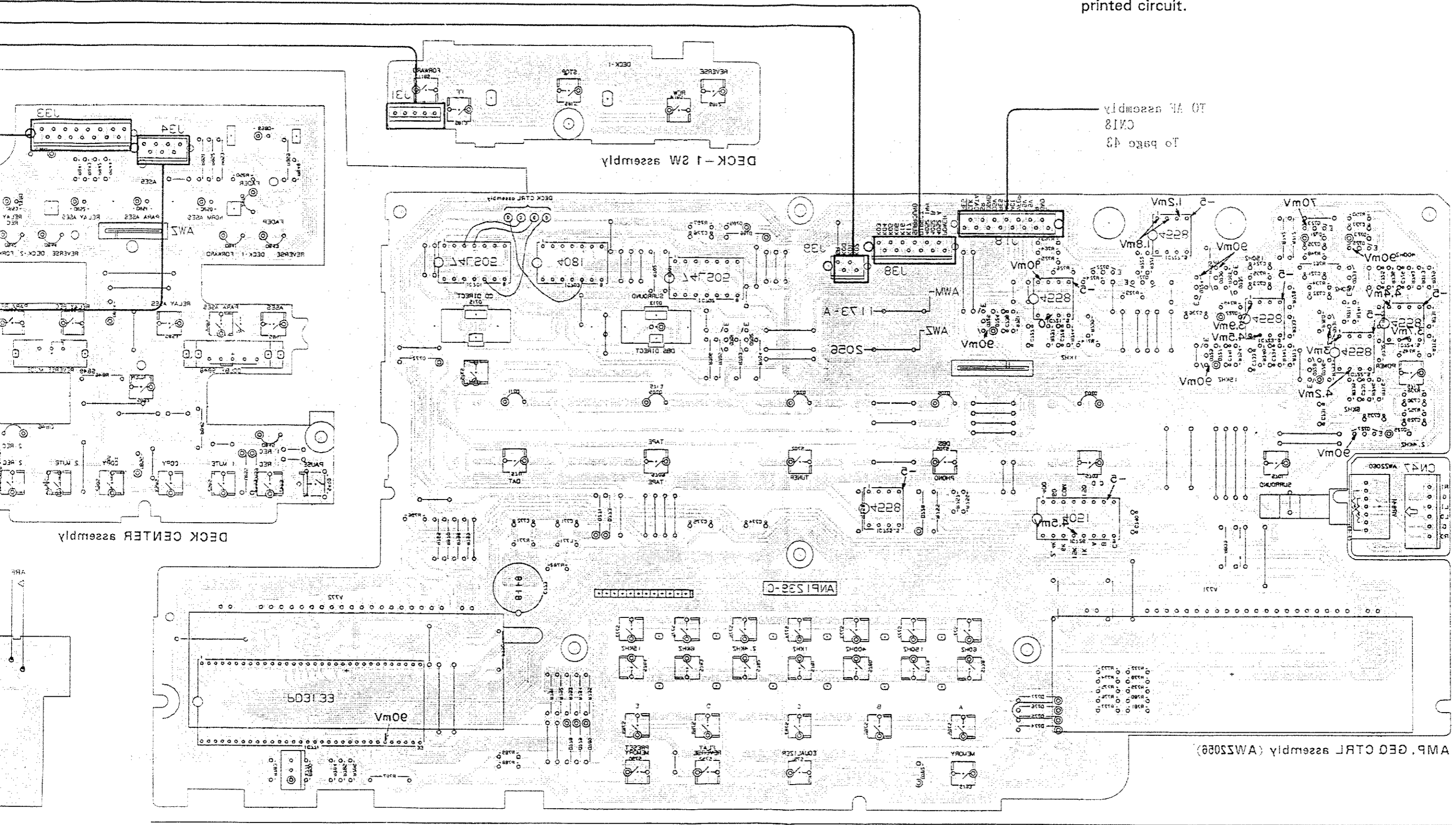

A
B
C
D

NOTE:
This picture shows the foil side of the printed circuit.

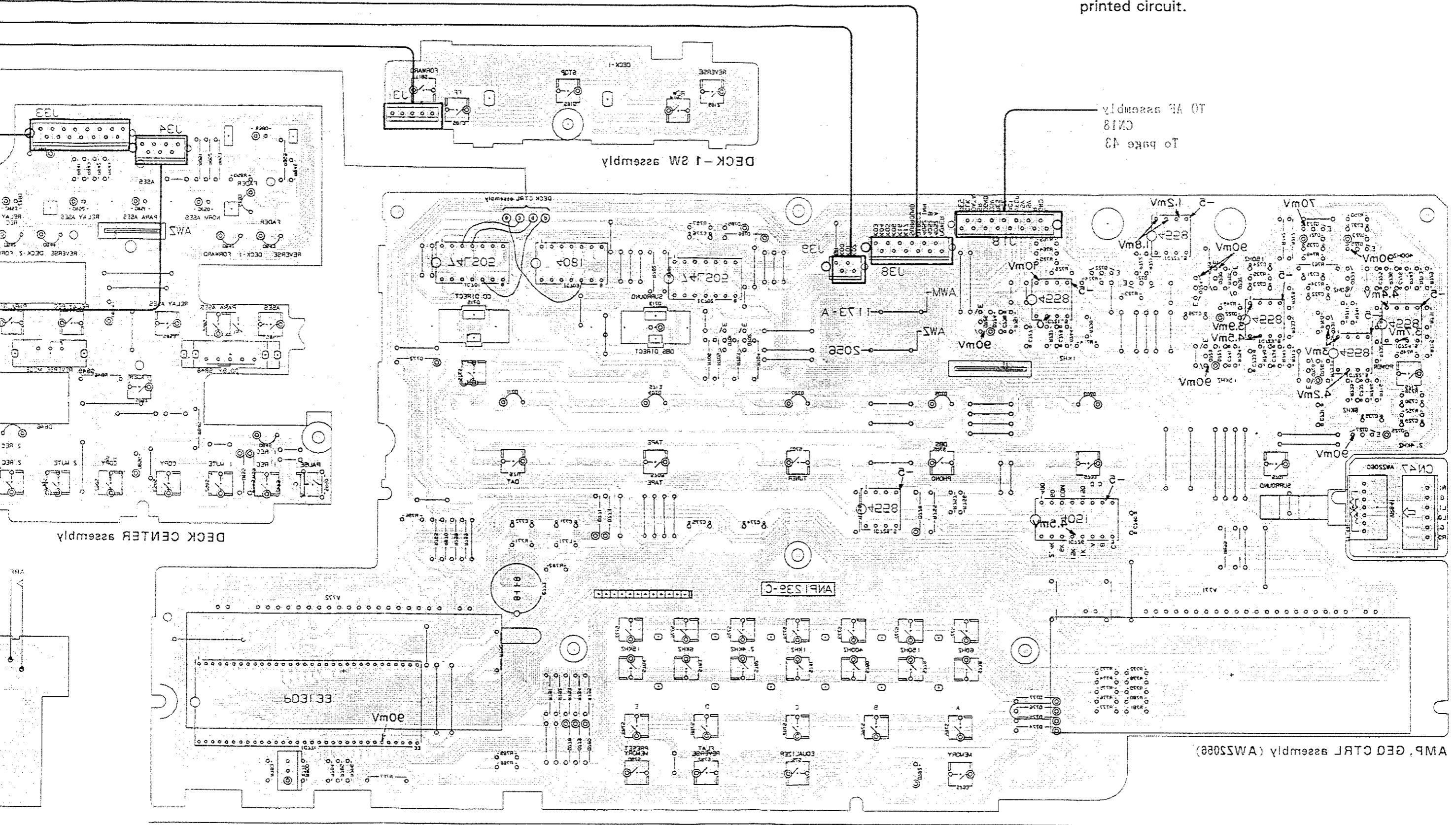

A
B
C
D

1C271

1C255

1C256

1C251-1C254
0251-0223
1C252

1C201-1C203
0205 0201

6

5

4

3

2

1

24

4.2 AMP, GEO CTRL (AWZ2056) , DECK -1SW, DECK -2SW, DECK CTRL (AWZ2319) DECK CENTER assembly, MECHA 1 and MECHA 2 UNIT.

A

B

C

D

TO AF assembly
CN18
To page 43

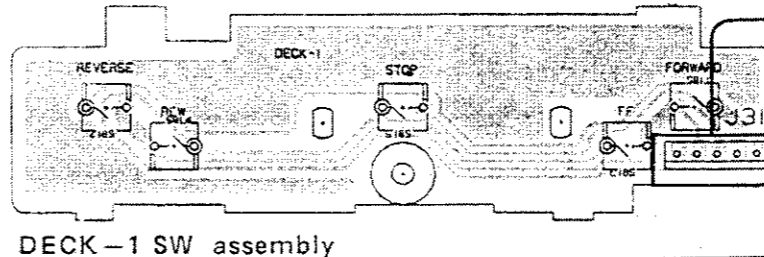

DECK -1 SW assembly

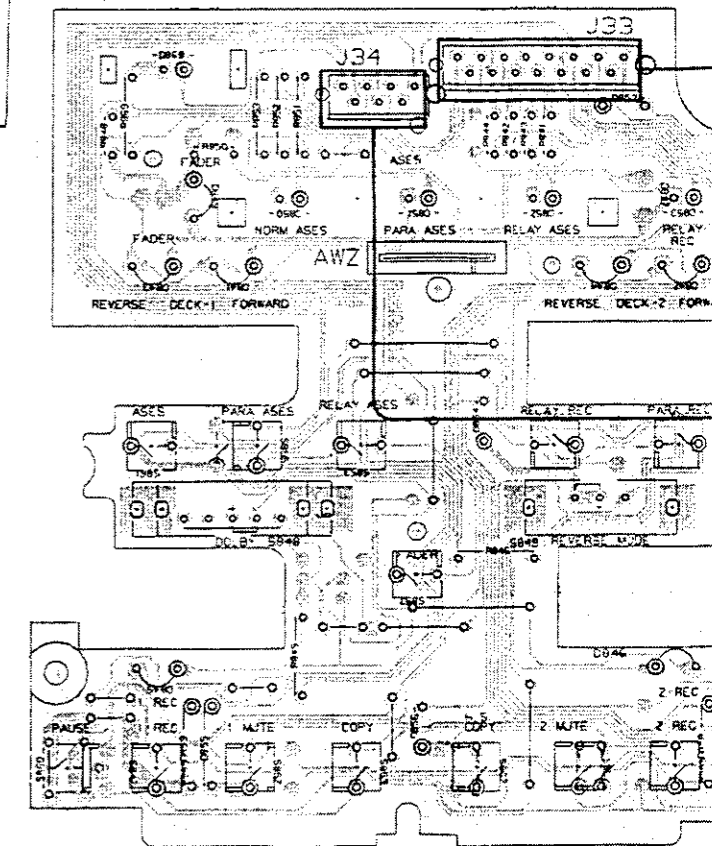

DECK CENTER assembly

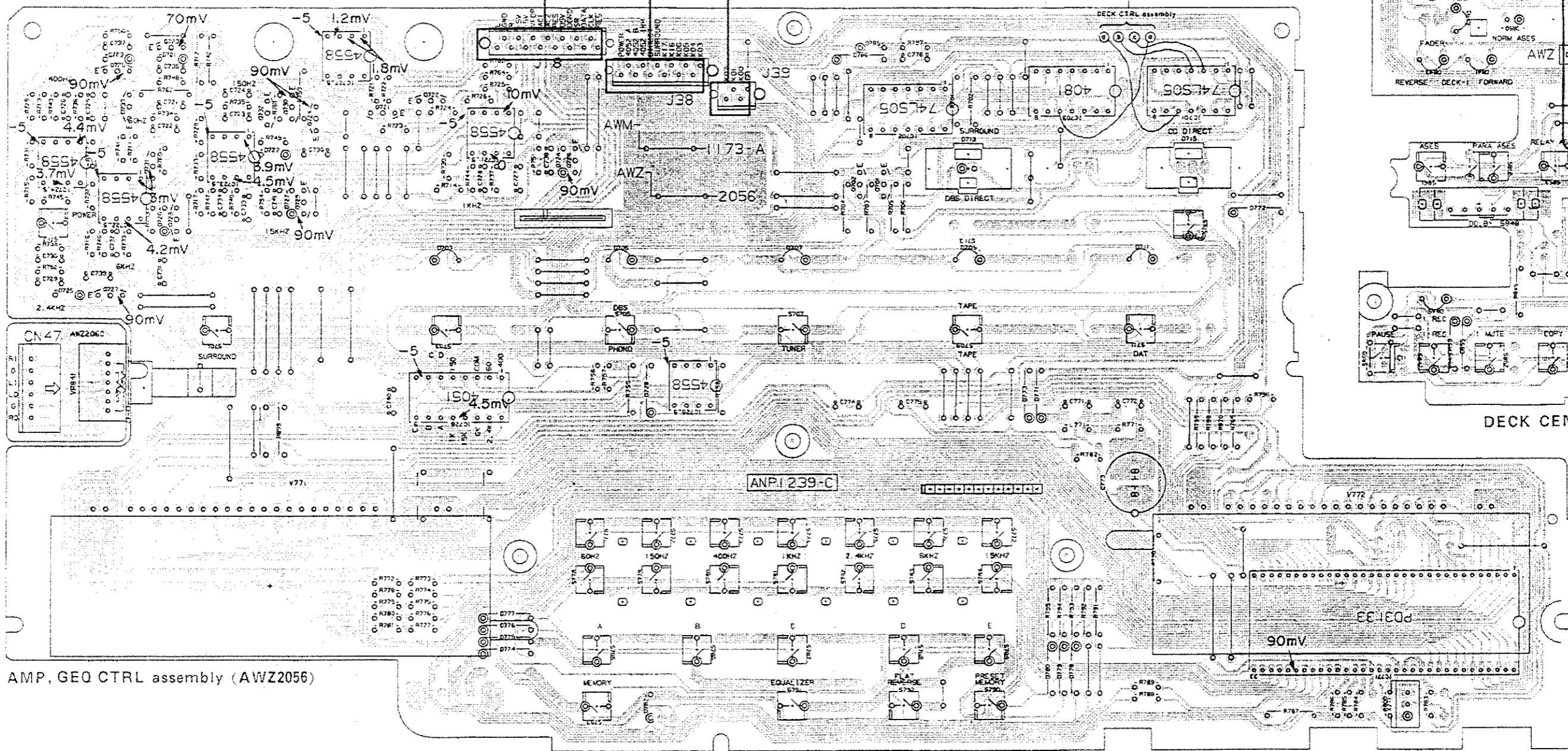

AMP, GEO CTRL assembly (AWZ2056)

IC721 - IC724

Q721 - Q733

IC727

IC726

IC725

Q702 Q701

IC701 - IC703

IC771

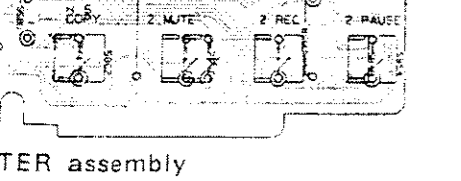
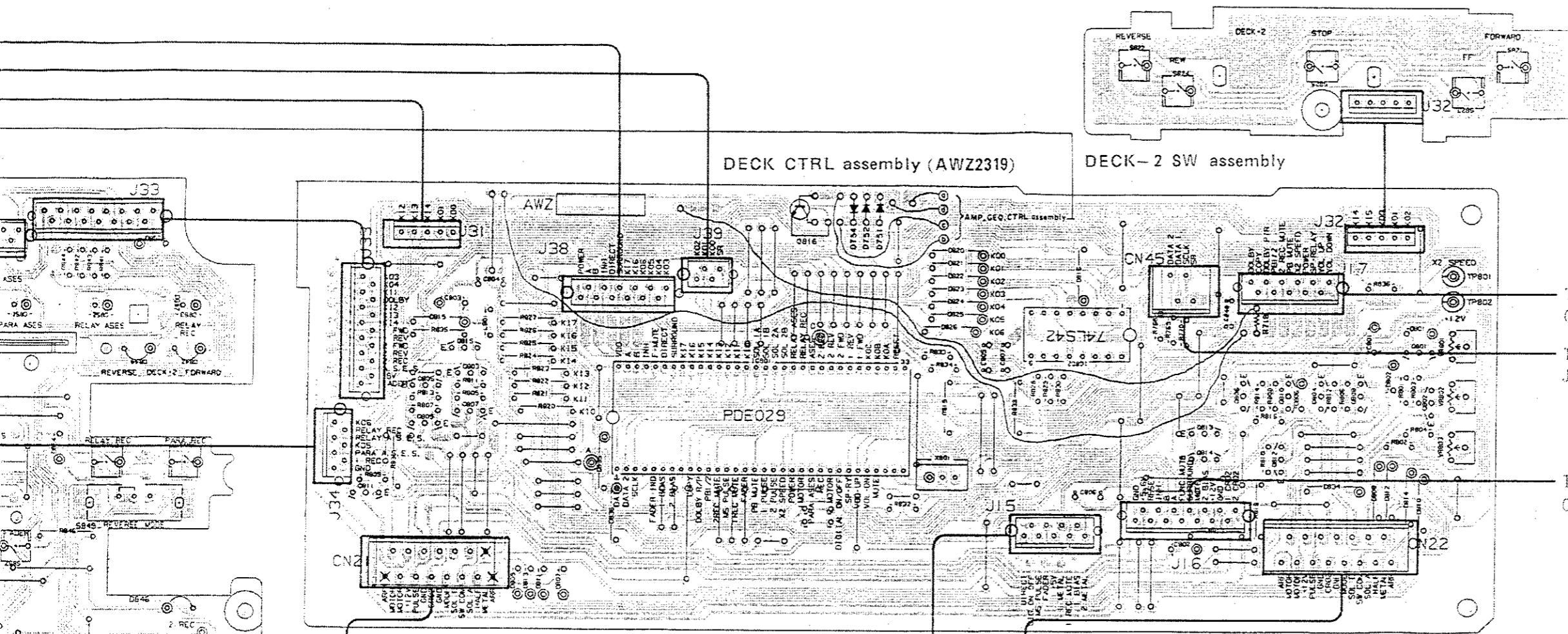

TER assembly

TO AF assembly
CN17 To page 44

TO AF assembly
J45 To page 44

TO AF assembly
CN16 To page 43

Q805 Q815 Q803 Q807 IC801 Q811 Q809

IC802 Q806 Q810 Q804 Q808 Q801 Q802 Q812-Q814 VR801-VR803

TO AF assembly
CN15
To page 43

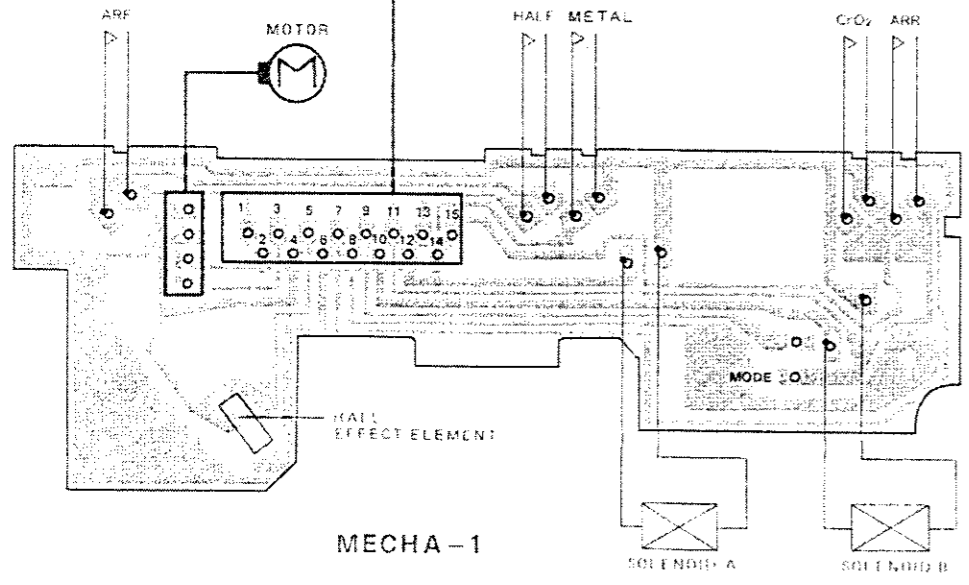

MECHA-1

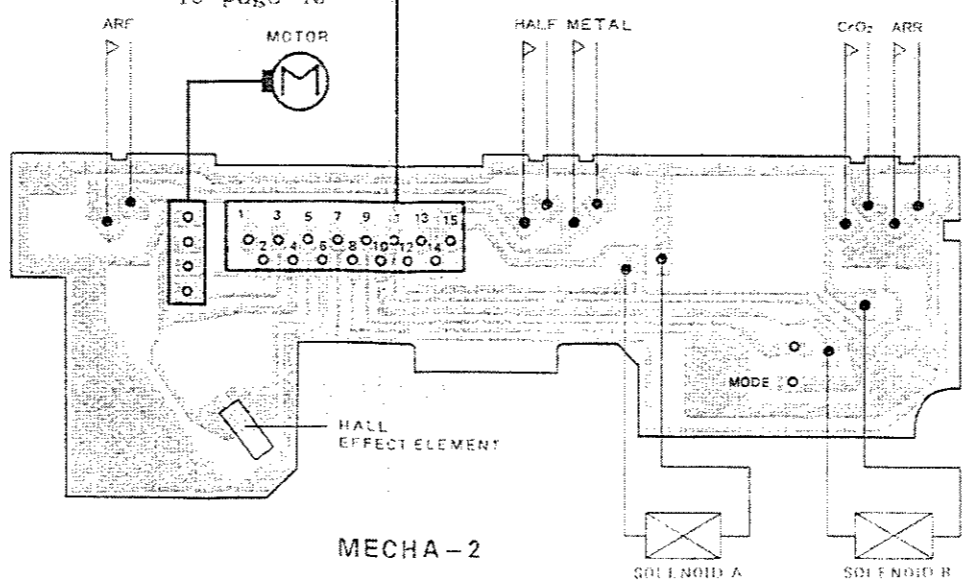

MECHA-2

NOTE

- This P.C.B. connection diagram is viewed from the parts mounted side.
- The parts which have been mounted on the board can be replaced with those shown with the corresponding wiring symbols listed in the following Table.

P.C.B. pattern diagram indication	Corresponding part symbol	Part Name
		Transistor
		Radiator type transistor
		Diode
		Resistor
		Capacitor (Polarity)
		Capacitor (Non-polarity)

P.C.B. pattern diagram indication	Part Name
IC	IC
S	Switch
RY	Relay
L	Coil
F	Filter
VR	Variable resistor or Semi-fixed resistor

- The capacitor terminal marked with (C) (double circles) shows negative terminal.
- The diode terminal marked with (C) (double circles) shows cathode side.
- The transistor terminal to which E is affixed shows the emitter.

A

B

C

D

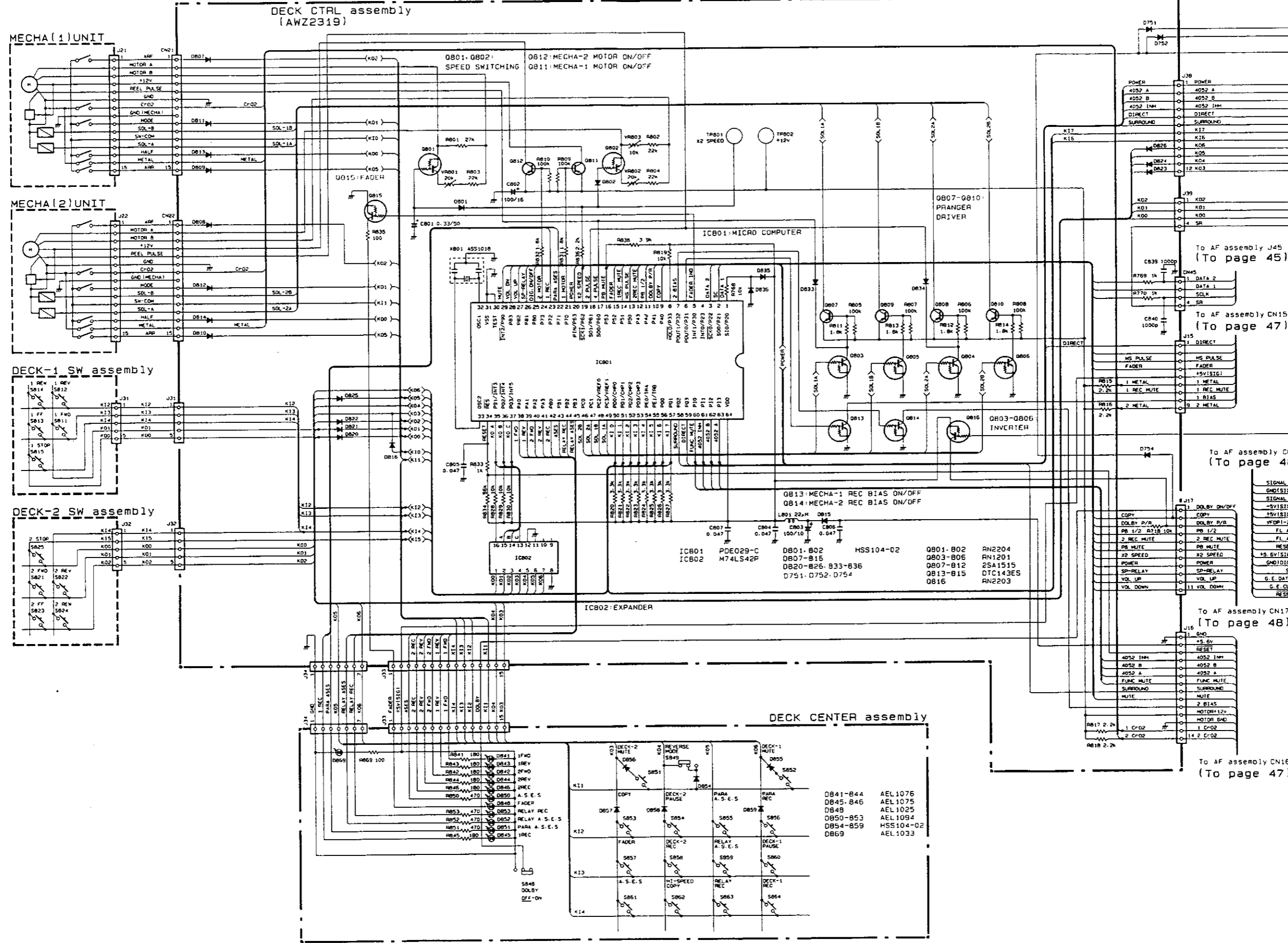

A

B

C

D

1

2

3

4

5

6

1

2

3

4

5

6

IC771: FOR DISPLAY MICRO COMPUTER

To AF assembly CN16 (To page 47)

To AF assembly CN17 (To page 48)

To AF assembly CN18 (To page 48)

To AF assembly CN15 (To page 47)

To AF assembly J45 (To page 45)

4.3 FUNCTION (AWK1174), GEQ (AWG1016) and REC assembly (AWK1178)

A

B

C

D

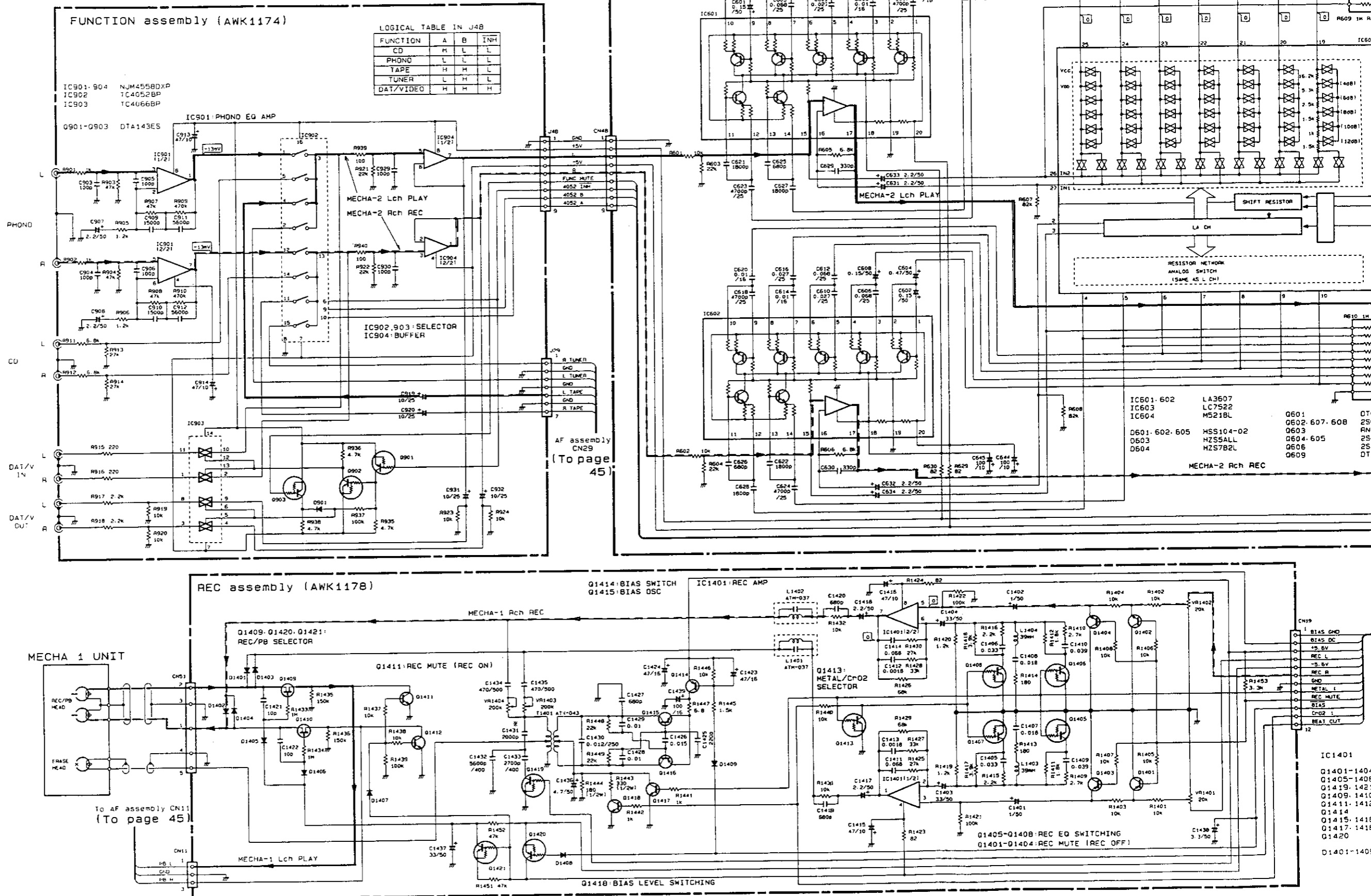

1178)

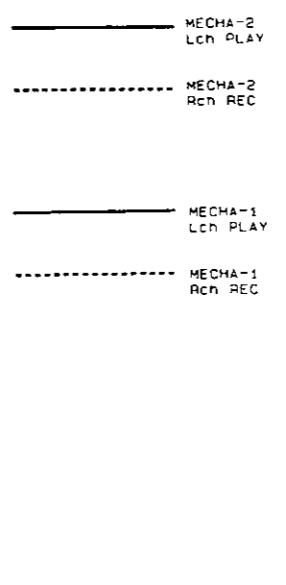
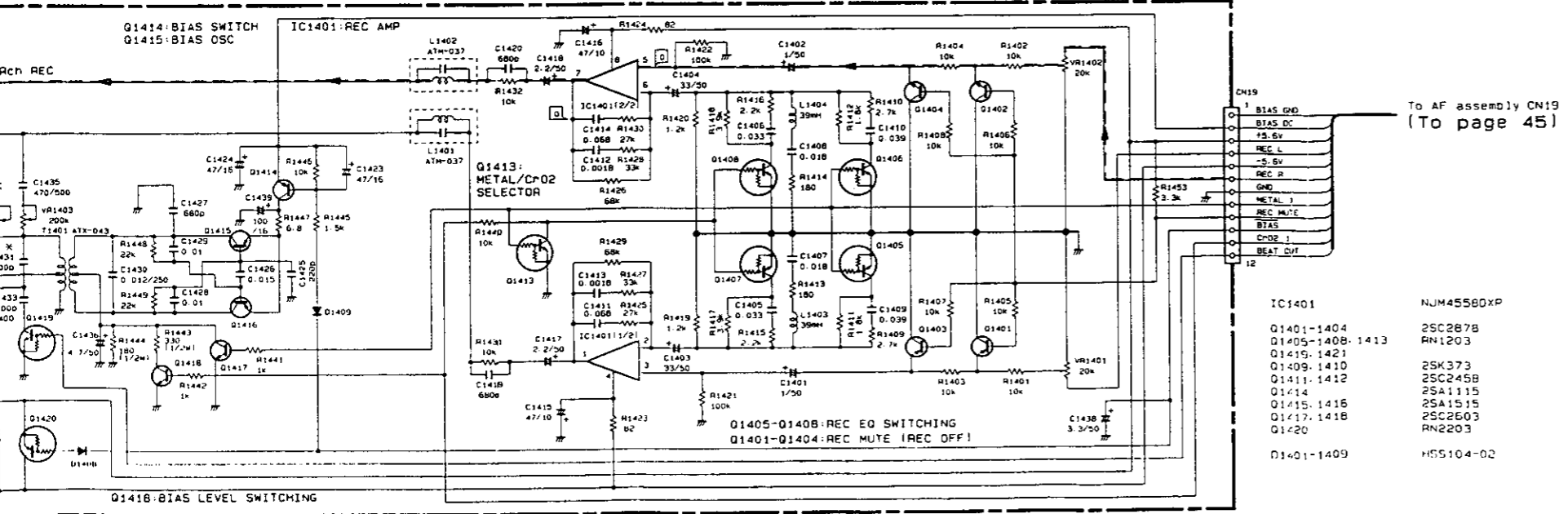
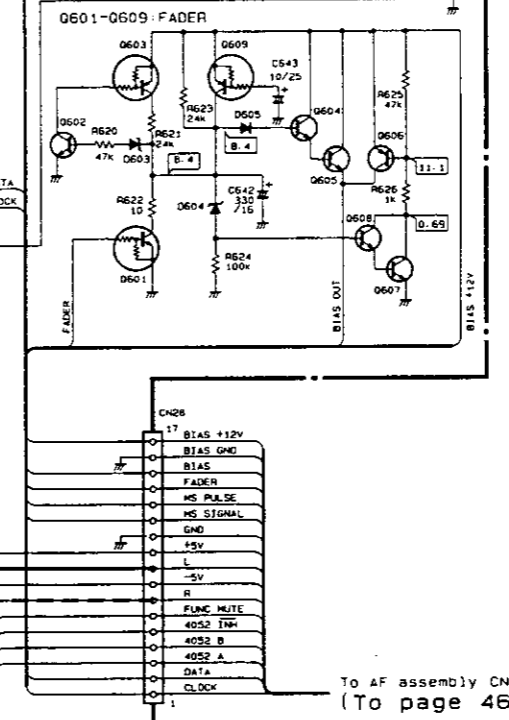
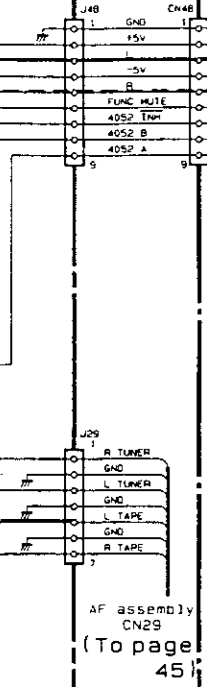
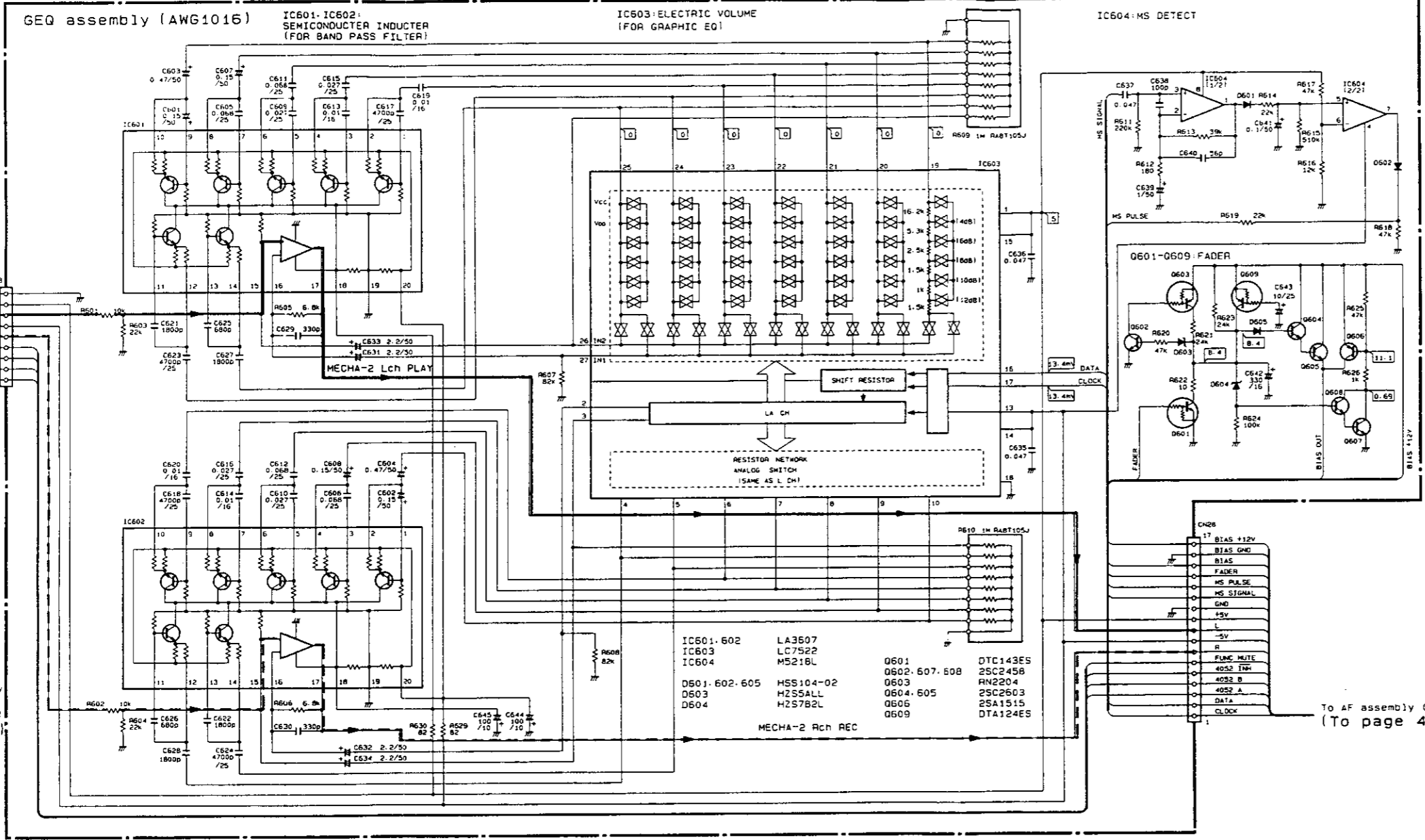

IC1401	NJM4558DXP
Q1401-1404	2SC287B
Q1405-1408, 1413	RN1203
Q1419, 1421	
Q1409, 1410	2SK373
Q1411, 1412	2SC245B
Q1414	2SA1115
Q1415, 1416	2SA1515
Q1417, 1418	2SC2603
Q1420	RN2203
Q1401-1409	HSS104-02

1

2

3

4

5

6

A

Q604 Q608 IC601 IC604 IC603
Q601 Q603 Q609

IC602

IC904

Q903 Q901 Q902
IC903

IC902

IC901

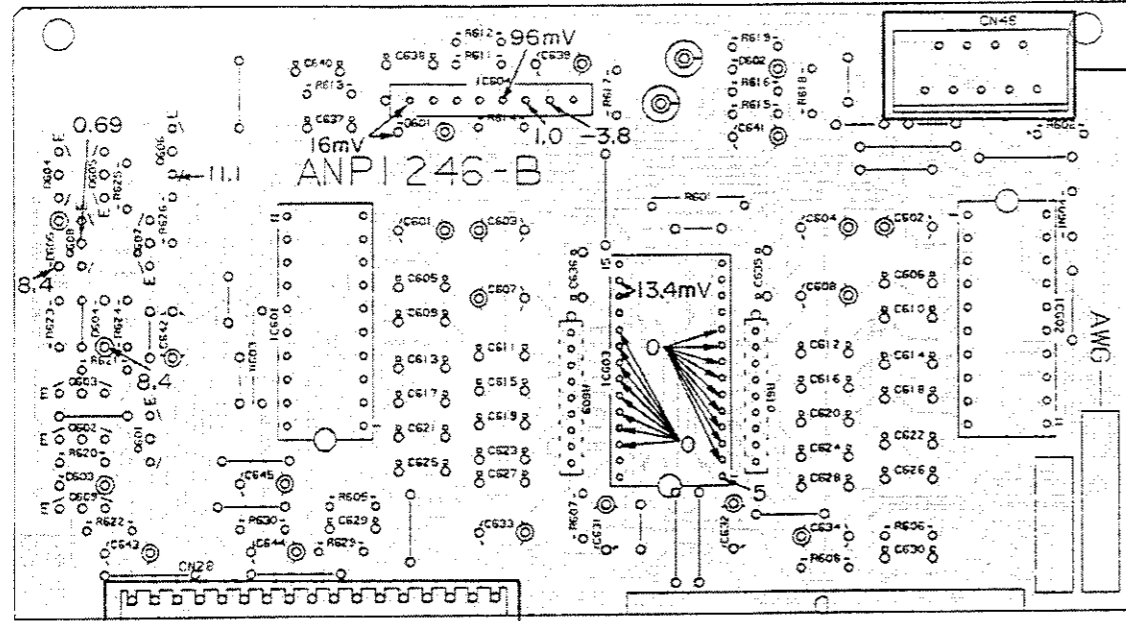

GEQ assembly (AWG1016)

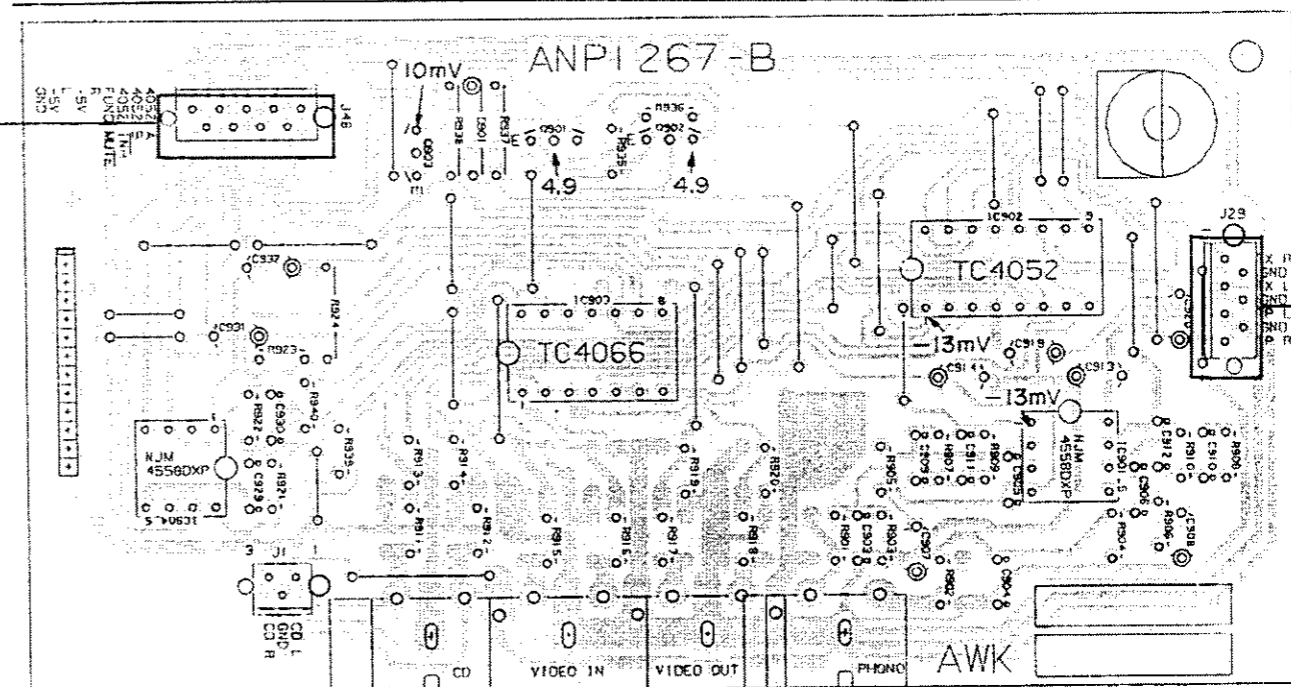

FUNCTION assembly (AWK1174)

TO AF assembly
CN29
To page 44

TO AF assembly
CN28
To page 43

REC assembly (AWK1178)

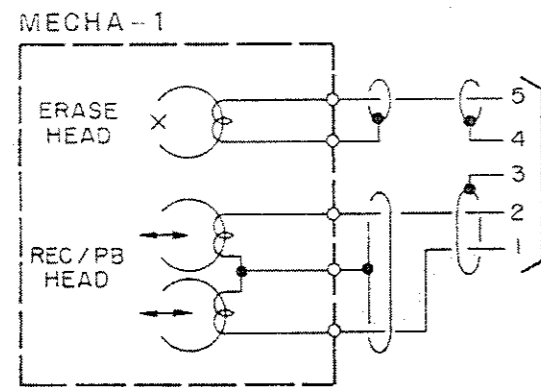

TO AF assembly
CN11
To page 43

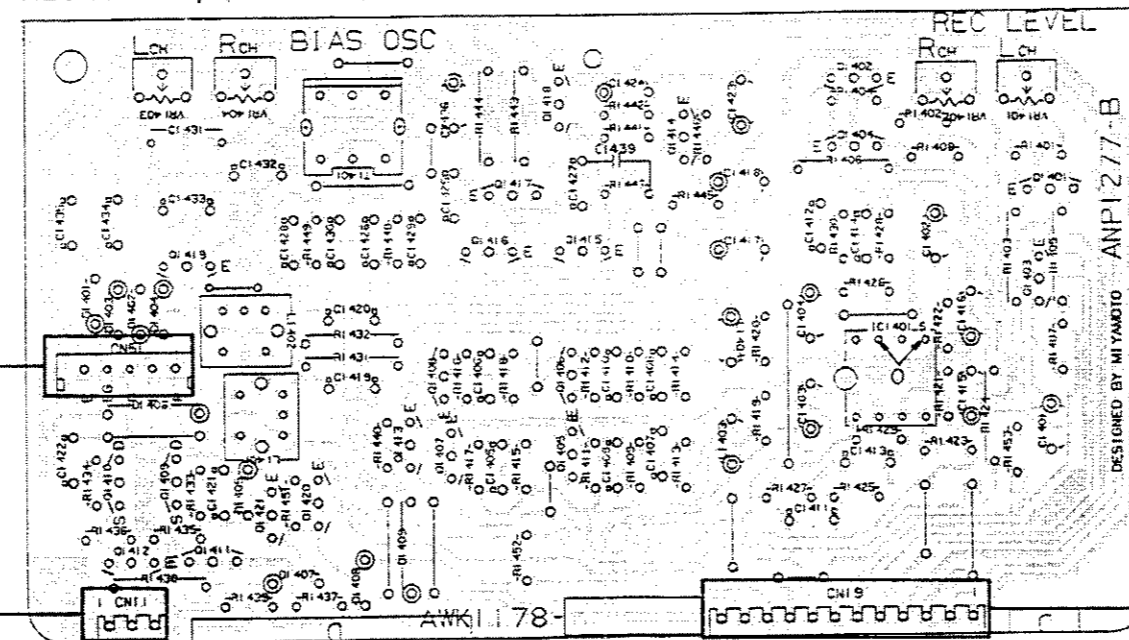

Q1419 Q1414-Q1418 Q1401-Q1404
Q1409-Q1412 Q1421 Q1420 Q1413 Q1405-Q1408 IC1401
VR1403 VR1404 VR1402 VR1401

TO AF assembly
CN19
To page 43

NOTE

1. This P.C.B. connection diagram is viewed from the parts mounted side.
2. The parts which have been mounted on the board can be replaced with those shown with the corresponding wiring symbols listed in the following Table.

P.C.B. pattern diagram indication	Corresponding part symbol	Part Name
EO Q504		Transistor
Q215		Radiation type transistor
Q203		Diode
R237		Resistor
C513		Capacitor (Polarity)
C518		Capacitor (Non-polarity)

Others

P.C.B. pattern diagram indication	Part Name
IC	IC
S	Switch
RY	Relay
L	Coil
F	Filter
VR	Variable resistor or Semi-fixed resistor

3. The capacitor terminal marked with ⊙ (double circles) shows negative terminal.
4. The diode terminal marked with ⊙ (double circles) shows cathode side.
5. The transistor terminal to which E is affixed shows the emitter.

1

2

3

4

5

6

NOTE:
This picture shows the foil side of the
printed circuit.

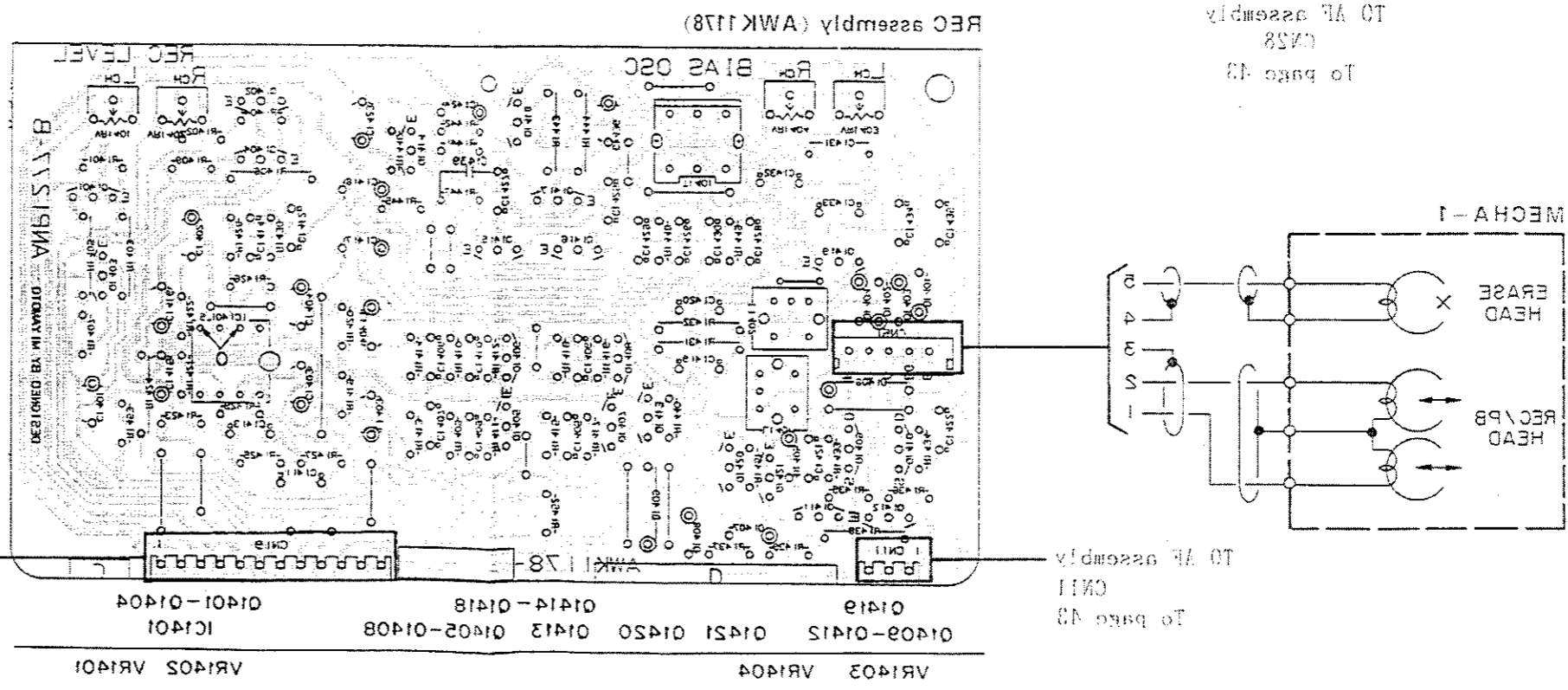
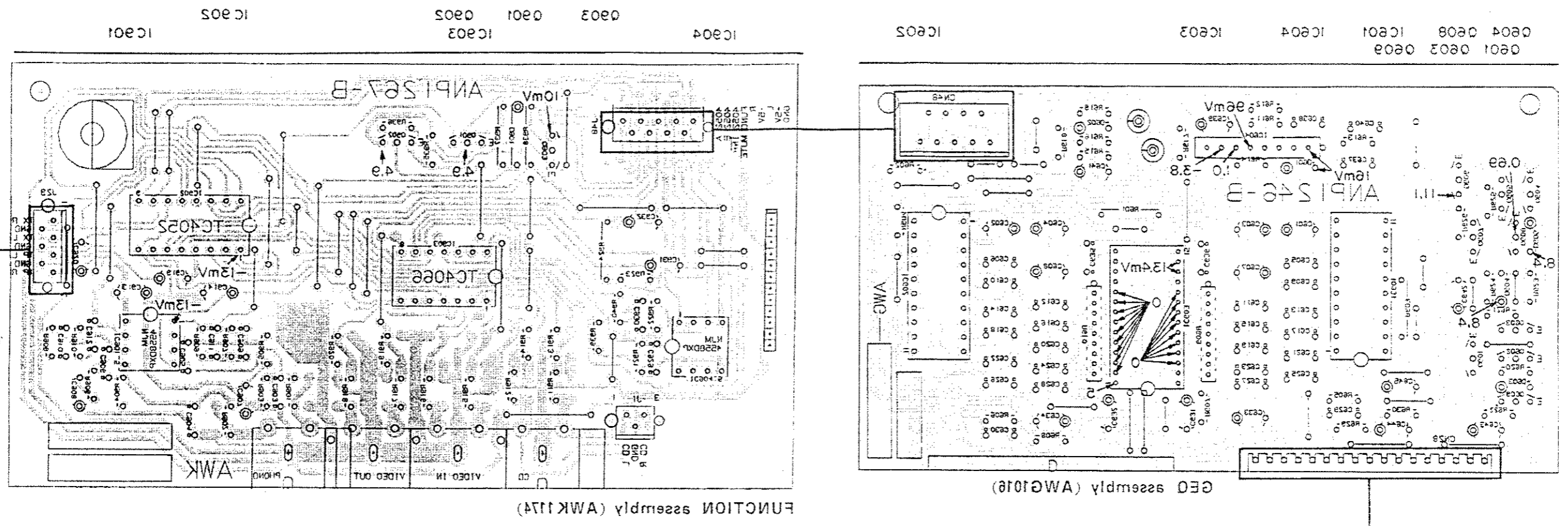

NOTE:
This picture shows the foil side of the
printed circuit.

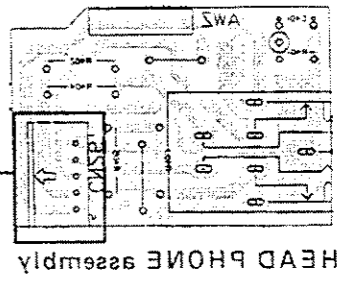
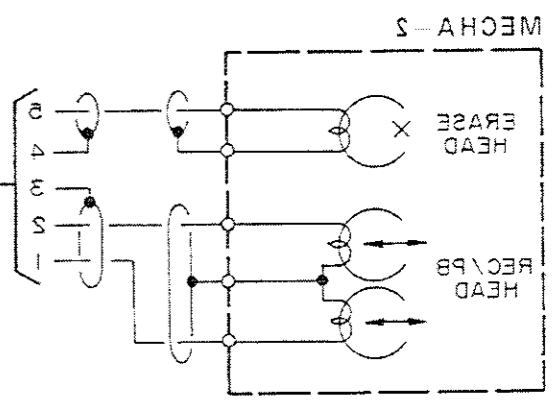
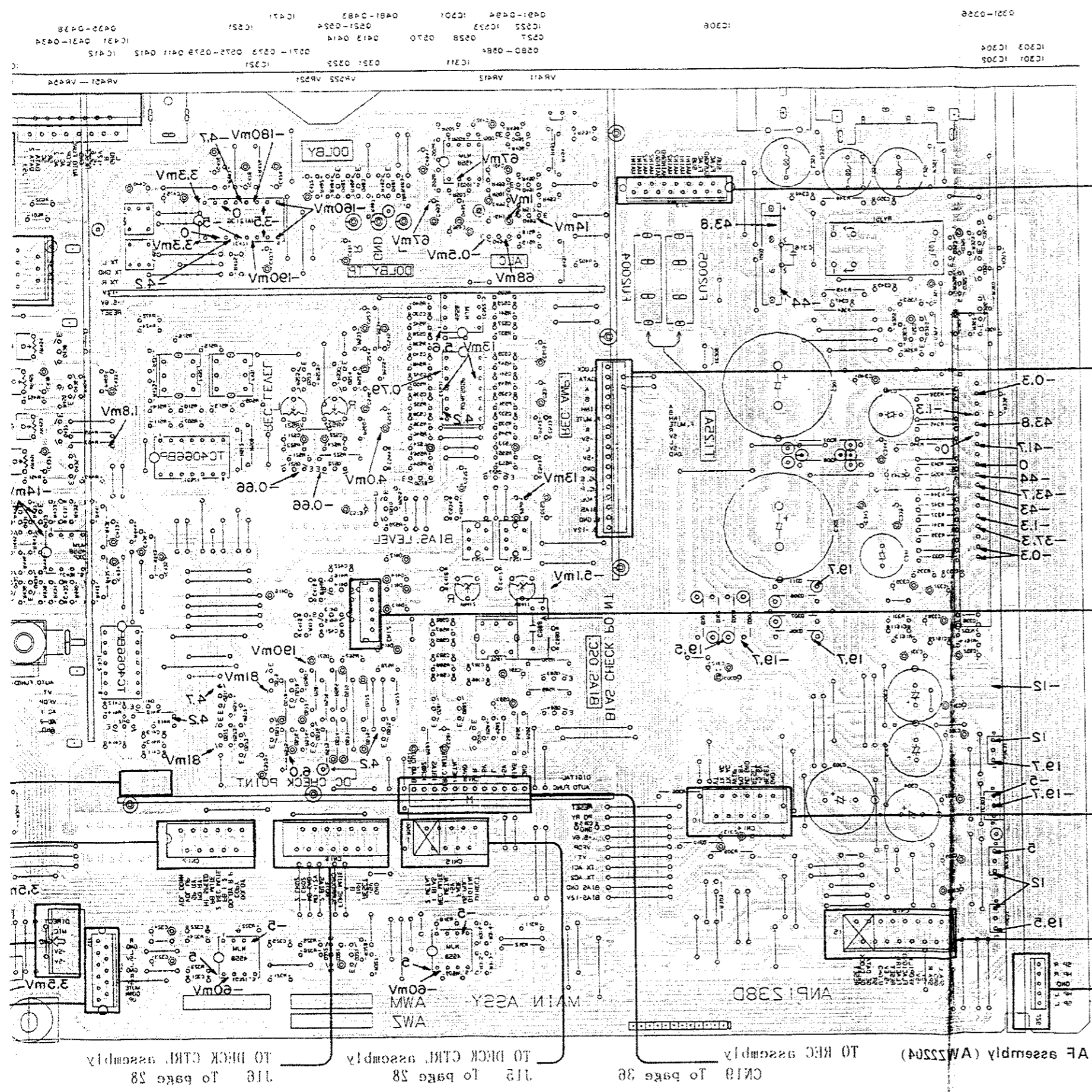

TO TRANS CONNECT Assembly
113
To page 31

TO GEO assembly
CN28
To page 32

TO POWER SUPPLY assembly
114
To page 30

TO AMP. GEO CTRL assembly
118
To page 32

AF assembly (AW2204) TO REC assembly
CN18 To page 38
TO DRCK CTRL assembly
116 To page 38
TO DRCK CTRL assembly
115 To page 38

A

B

C

D

1

2

3

4

5

6

A

B

C

D

MECHA-2 Lch PLAY
MECHA-1 Lch PLAY
MECHA-2 Rch REC
MECHA-1 Rch REC

MIC BALANCE assembly IC371(1/2)-AMP
IC371(2/2)-Q372 BUFFER
Q371-MUTE
MAIN

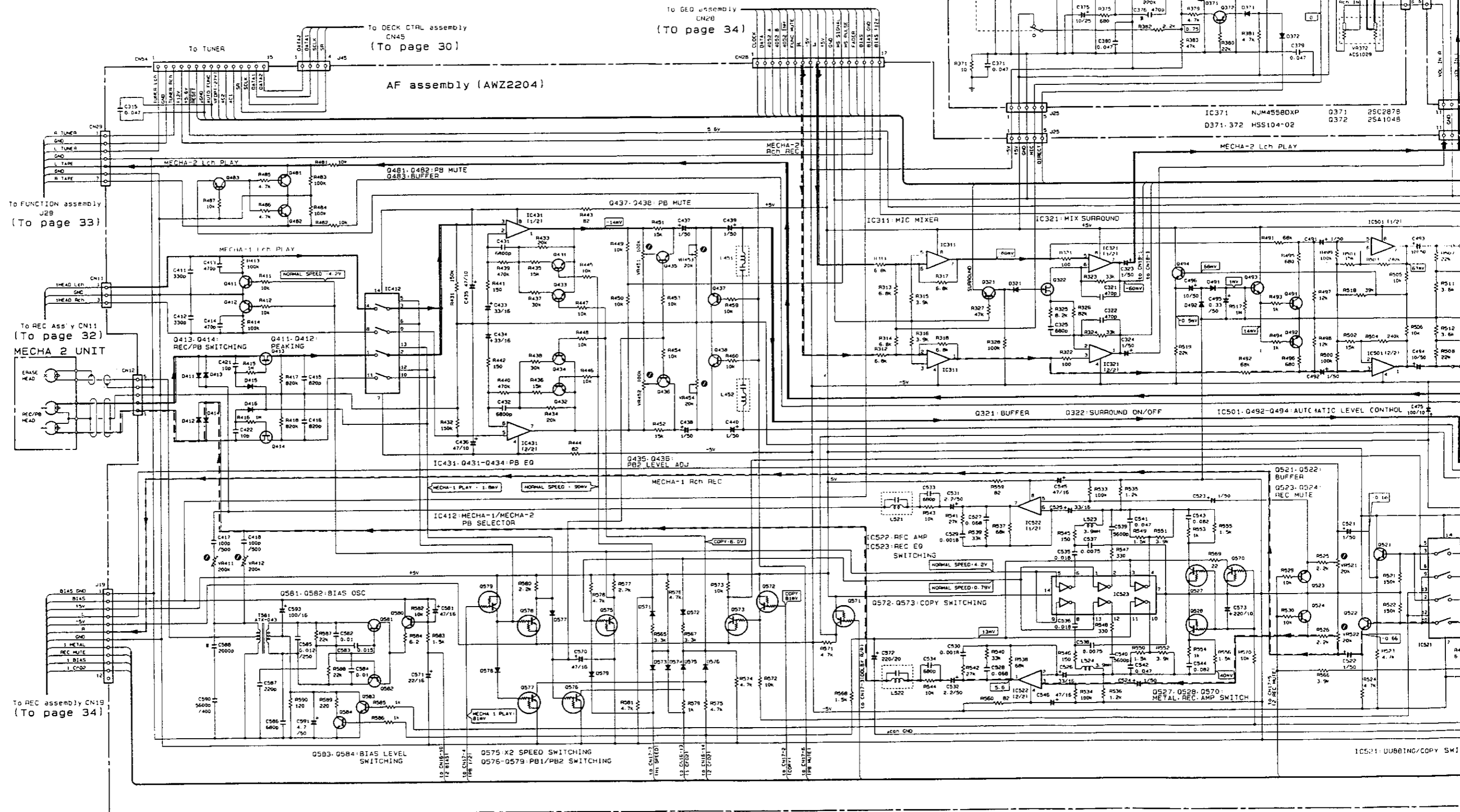

1

2

3

4

5

6

7

8

9

10

11

12

A

B

C

D

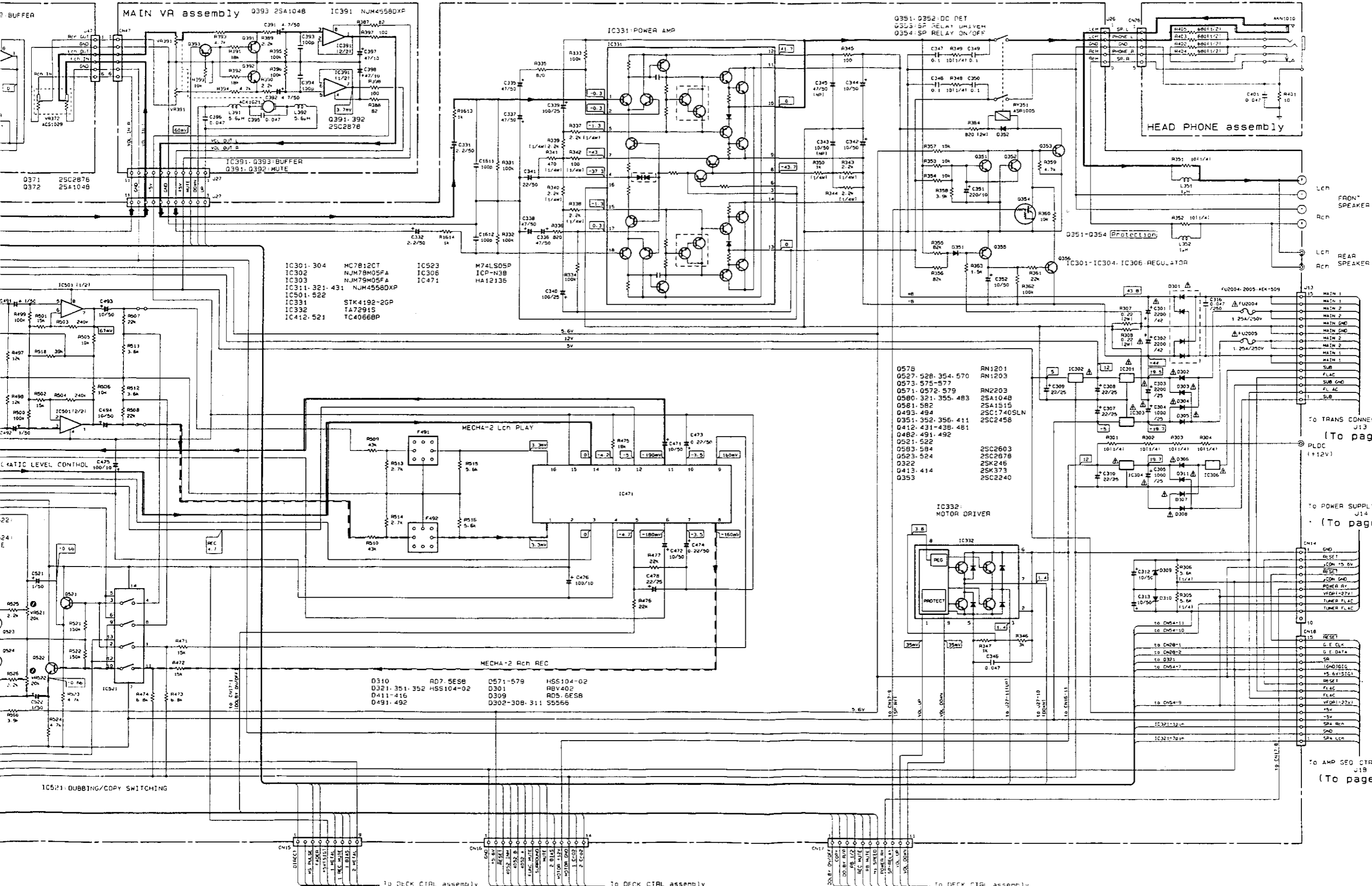

Q371 25C2876
Q372 25A1048

IC301: 304 MC7812CT
IC302 NJM78M05FA
IC303 NJM79M05FA
IC311: 321-431 NJM4558DXP
IC311: 522 STK4192-2GP
IC331 TA72915
IC332 TC4066BP
IC333
IC412: 521

0578 AN1201
0527: 528-354-570 AN1203
0573: 575-577
0571: 0572-579 RN2203
0580: 321-355-483 25A1048
0581: 582 25A1515
0493: 494 25C1740SLN
0351: 352-356-411 25C2458
0412: 431-438-481
0482: 491-492
0521: 522
0583: 584 25C2603
0523: 524 25C2678
0322 25K246
0413: 414 25K373
0353 25C2240

D310 AD7.5E58
D321: 351-352 HSS104-02
D411-416
D491-492
D571-579 HSS104-02
D301 RBV402
D309 RDS.6E58
D302-308: 311 S5556

7

8

9

10

11

12

To DECK CTRL assembly J15
(To page 30)

To DECK CTRL assembly J16
(To page 30)

To DECK CTRL assembly J17
(To page 30)

To AMP GEO CTRL assembly J19
(To page 30)

To POWER SUPPLY assembly J14
(To page 49)

To TRANS CONNECT assembly J13
(To page 49)

PLDC (+12V)

LCh FRONT SPEAKER
Rch REAR SPEAKER

HEAD PHONE assembly

IC331: POWER AMP

MAIN VR assembly Q393 25A1048 IC391 NJM4558DXP

Q351: Q352: DC NET
Q353: SP RELAY L/UM/VEN
Q354: SP RELAY ON/OFF

2 BUFFER

IC521: DUBBING/COPY SWITCHING

MECHA-2 Lch PLAY

MECHA-2 Rch REC

IC332: MOTOR DRIVER

HEAD PHONE assembly

IC331: POWER AMP

MAIN VR assembly Q393 25A1048 IC391 NJM4558DXP

Q351: Q352: DC NET
Q353: SP RELAY L/UM/VEN
Q354: SP RELAY ON/OFF

2 BUFFER

IC521: DUBBING/COPY SWITCHING

MECHA-2 Lch PLAY

MECHA-2 Rch REC

IC332: MOTOR DRIVER

HEAD PHONE assembly

IC331: POWER AMP

MAIN VR assembly Q393 25A1048 IC391 NJM4558DXP

Q351: Q352: DC NET
Q353: SP RELAY L/UM/VEN
Q354: SP RELAY ON/OFF

2 BUFFER

IC521: DUBBING/COPY SWITCHING

MECHA-2 Lch PLAY

MECHA-2 Rch REC

IC332: MOTOR DRIVER

HEAD PHONE assembly

IC331: POWER AMP

MAIN VR assembly Q393 25A1048 IC391 NJM4558DXP

Q351: Q352: DC NET
Q353: SP RELAY L/UM/VEN
Q354: SP RELAY ON/OFF

2 BUFFER

IC521: DUBBING/COPY SWITCHING

MECHA-2 Lch PLAY

MECHA-2 Rch REC

IC332: MOTOR DRIVER

HEAD PHONE assembly

IC331: POWER AMP

MAIN VR assembly Q393 25A1048 IC391 NJM4558DXP

Q351: Q352: DC NET
Q353: SP RELAY L/UM/VEN
Q354: SP RELAY ON/OFF

2 BUFFER

IC521: DUBBING/COPY SWITCHING

MECHA-2 Lch PLAY

MECHA-2 Rch REC

IC332: MOTOR DRIVER

HEAD PHONE assembly

IC331: POWER AMP

MAIN VR assembly Q393 25A1048 IC391 NJM4558DXP

Q351: Q352: DC NET
Q353: SP RELAY L/UM/VEN
Q354: SP RELAY ON/OFF

2 BUFFER

IC521: DUBBING/COPY SWITCHING

MECHA-2 Lch PLAY

MECHA-2 Rch REC

IC332: MOTOR DRIVER

HEAD PHONE assembly

IC331: POWER AMP

MAIN VR assembly Q393 25A1048 IC391 NJM4558DXP

Q351: Q352: DC NET
Q353: SP RELAY L/UM/VEN
Q354: SP RELAY ON/OFF

2 BUFFER

IC521: DUBBING/COPY SWITCHING

MECHA-2 Lch PLAY

MECHA-2 Rch REC

IC332: MOTOR DRIVER

HEAD PHONE assembly

IC331: POWER AMP

MAIN VR assembly Q393 25A1048 IC391 NJM4558DXP

Q351: Q352: DC NET
Q353: SP RELAY L/UM/VEN
Q354: SP RELAY ON/OFF

2 BUFFER

IC521: DUBBING/COPY SWITCHING

MECHA-2 Lch PLAY

MECHA-2 Rch REC

IC332: MOTOR DRIVER

HEAD PHONE assembly

IC331: POWER AMP

MAIN VR assembly Q393 25A1048 IC391 NJM4558DXP

Q351: Q352: DC NET
Q353: SP RELAY L/UM/VEN
Q354: SP RELAY ON/OFF

2 BUFFER

IC521: DUBBING/COPY SWITCHING

MECHA-2 Lch PLAY

MECHA-2 Rch REC

IC332: MOTOR DRIVER

HEAD PHONE assembly

IC331: POWER AMP

MAIN VR assembly Q393 25A1048 IC391 NJM4558DXP

Q351: Q352: DC NET
Q353: SP RELAY L/UM/VEN
Q354: SP RELAY ON/OFF

2 BUFFER

IC521: DUBBING/COPY SWITCHING

MECHA-2 Lch PLAY

MECHA-2 Rch REC

IC332: MOTOR DRIVER

HEAD PHONE assembly

IC331: POWER AMP

MAIN VR assembly Q393 25A1048 IC391 NJM4558DXP

Q351: Q352: DC NET
Q353: SP RELAY L/UM/VEN
Q354: SP RELAY ON/OFF

2 BUFFER

IC521: DUBBING/COPY SWITCHING

MECHA-2 Lch PLAY

MECHA-2 Rch REC

IC332: MOTOR DRIVER

HEAD PHONE assembly

IC331: POWER AMP

MAIN VR assembly Q393 25A1048 IC391 NJM4558DXP

Q351: Q352: DC NET
Q353: SP RELAY L/UM/VEN
Q354: SP RELAY ON/OFF

2 BUFFER

IC521: DUBBING/COPY SWITCHING

MECHA-2 Lch PLAY

MECHA-2 Rch REC

IC332: MOTOR DRIVER

HEAD PHONE assembly

IC331: POWER AMP

MAIN VR assembly Q393 25A1048 IC391 NJM4558DXP

Q351: Q352: DC NET
Q353: SP RELAY L/UM/VEN
Q354: SP RELAY ON/OFF

2 BUFFER

IC521: DUBBING/COPY SWITCHING

MECHA-2 Lch PLAY

MECHA-2 Rch REC

IC332: MOTOR DRIVER

HEAD PHONE assembly

IC331: POWER AMP

MAIN VR assembly Q393 25A1048 IC391 NJM4558DXP

Q351: Q352: DC NET
Q353: SP RELAY L/UM/VEN
Q354: SP RELAY ON/OFF

2 BUFFER

IC521: DUBBING/COPY SWITCHING

MECHA-2 Lch PLAY

MECHA-2 Rch REC

IC332: MOTOR DRIVER

HEAD PHONE assembly

IC331: POWER AMP

MAIN VR assembly Q393 25A1048 IC391 NJM4558DXP

Q351: Q352: DC NET
Q353: SP RELAY L/UM/VEN
Q354: SP RELAY ON/OFF

2 BUFFER

IC521: DUBBING/COPY SWITCHING

MECHA-2 Lch PLAY

MECHA-2 Rch REC

IC332: MOTOR DRIVER

HEAD PHONE assembly

IC331: POWER AMP

MAIN VR assembly Q393 25A1048 IC391 NJM4558DXP

Q351: Q352: DC NET
Q353: SP RELAY L/UM/VEN
Q354: SP RELAY ON/OFF

2 BUFFER

IC521: DUBBING/COPY SWITCHING

MECHA-2 Lch PLAY

MECHA-2 Rch REC

IC332: MOTOR DRIVER

HEAD PHONE assembly

IC331: POWER AMP

MAIN VR assembly Q393 25A1048 IC391 NJM4558DXP

Q351: Q352: DC NET
Q353: SP RELAY L/UM/VEN
Q354: SP RELAY ON/OFF

2 BUFFER

IC521: DUBBING/COPY SWITCHING

MECHA-2 Lch PLAY

MECHA-2 Rch REC

IC332: MOTOR DRIVER

HEAD PHONE assembly

IC331: POWER AMP

MAIN VR assembly Q393 25A1048 IC391 NJM4558DXP

Q351: Q352: DC NET
Q353: SP RELAY L/UM/VEN
Q354: SP RELAY ON/OFF

2 BUFFER

IC521: DUBBING/COPY SWITCHING

MECHA-2 Lch PLAY

MECHA-2 Rch REC

IC332: MOTOR DRIVER

HEAD PHONE assembly

IC331: POWER AMP

MAIN VR assembly Q393 25A1048 IC391 NJM4558DXP

Q351: Q352: DC NET
Q353: SP RELAY L/UM/VEN
Q354: SP RELAY ON/OFF

2 BUFFER

IC521: DUBBING/COPY SWITCHING

MECHA-2 Lch PLAY

MECHA-2 Rch REC

IC332: MOTOR DRIVER

HEAD PHONE assembly

IC331: POWER AMP

MAIN VR assembly Q393 25A1048 IC391 NJM4558DXP

Q351: Q352: DC NET
Q353: SP RELAY L/UM/VEN
Q354: SP RELAY ON/OFF

2 BUFFER

IC521: DUBBING/COPY SWITCHING

MECHA-2 Lch PLAY

MECHA-2 Rch REC

IC332: MOTOR DRIVER

HEAD PHONE assembly

IC331: POWER AMP

MAIN VR assembly Q393 25A1048 IC391 NJM4558DXP

Q351: Q352: DC NET
Q353: SP RELAY L/UM/VEN
Q354: SP RELAY ON/OFF

2 BUFFER

IC521: DUBBING/COPY SWITCHING

MECHA-2 Lch PLAY

MECHA-2 Rch REC

IC332: MOTOR DRIVER

HEAD PHONE assembly

IC331: POWER AMP

MAIN VR assembly Q393 25A1048 IC391 NJM4558DXP

Q351: Q352: DC NET
Q353: SP RELAY L/UM/VEN
Q354: SP RELAY ON/OFF

2 BUFFER

IC521: DUBBING/COPY SWITCHING

MECHA-2 Lch PLAY

MECHA-2 Rch REC

IC332: MOTOR DRIVER

HEAD PHONE assembly

IC331: POWER AMP

MAIN VR assembly Q393 25A1048 IC391 NJM4558DXP

Q351: Q352: DC NET
Q353: SP RELAY L/UM/VEN
Q354: SP RELAY ON/OFF

2 BUFFER

IC521: DUBBING/COPY SWITCHING

MECHA-2 Lch PLAY

MECHA-2 Rch REC

IC332: MOTOR DRIVER

HEAD PHONE assembly

IC331: POWER AMP

MAIN VR assembly Q393 25A1048 IC391 NJM4558DXP

Q351: Q352: DC NET
Q353: SP RELAY L/UM/VEN
Q354: SP RELAY ON/OFF

2 BUFFER

4.5 POWER SUPPLY (AWZ2241), CONNECT and TRANS CONNECT assembly

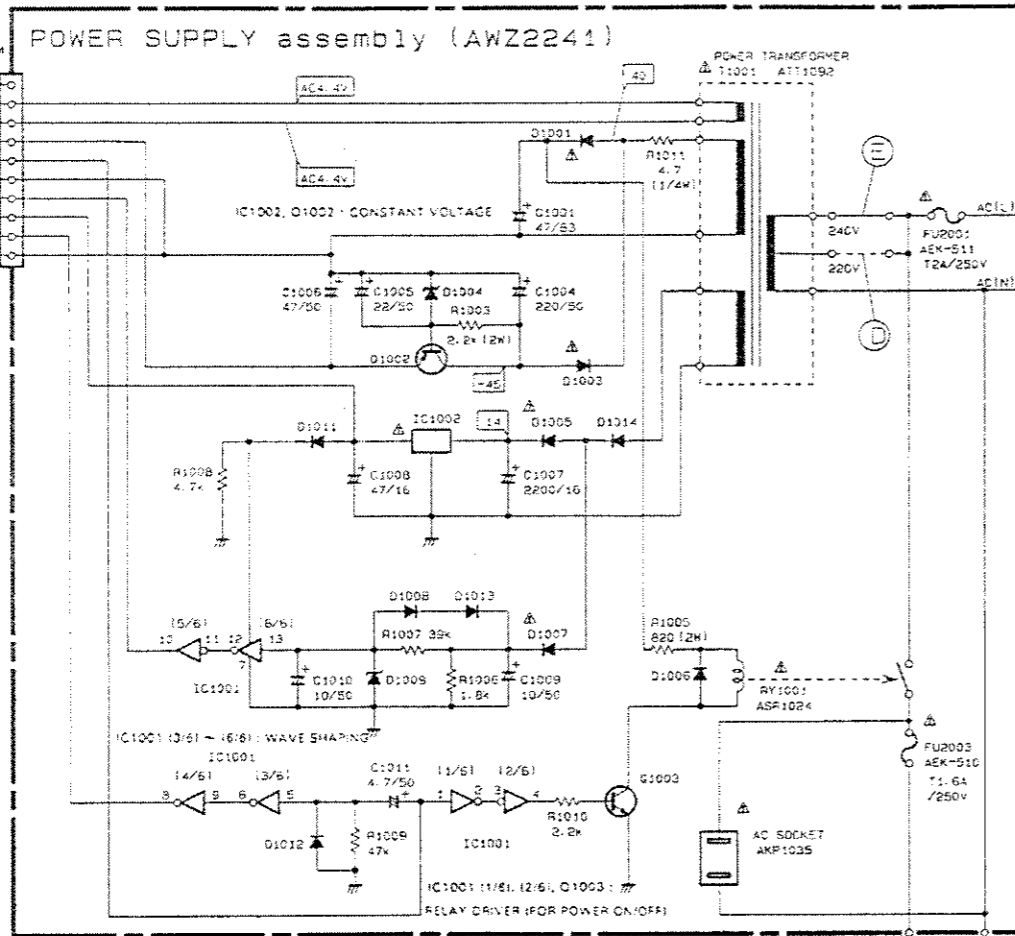

IC1001	TC4069UBP	D1001, 1003, 1005	S5566
IC1002	LM78M56FA	D1002, 1014	
		D1004	RD33ESB2
G1003	25C2240	D1006, 1008	HSS104-02
G1002	25B550	D1011-1013	FD5.1ESB
		D1009	

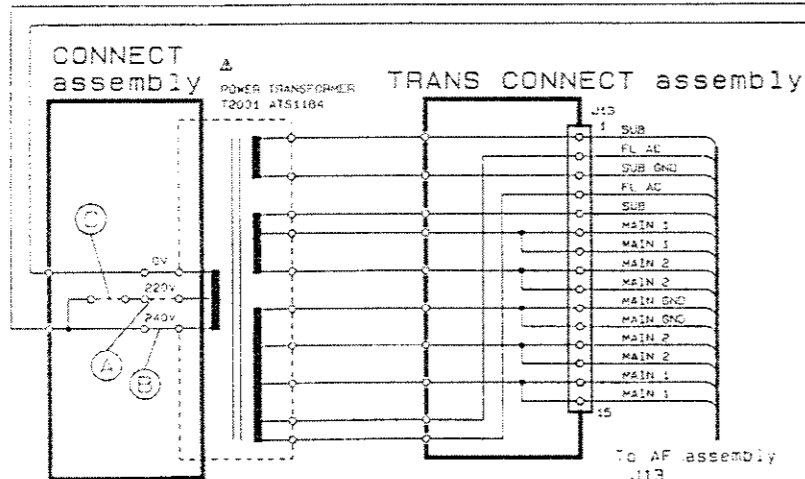

To AF assembly J13
(To page 48)

Line Voltage Selection (FOR HB AND HE TYPES)

- Line voltage can be changed with the following steps.
1. Disconnect the AC power cord.
 2. Remove the top cover.
 3. Change the position of the jumper wires A-E as follows.
 4. Stick the line voltage label on the rear panel.

Jumper wire	220V	240V
A	○	×
B	×	○
C	○	×
D	○	×
E	×	○

○ : Be needed
× : Be needless

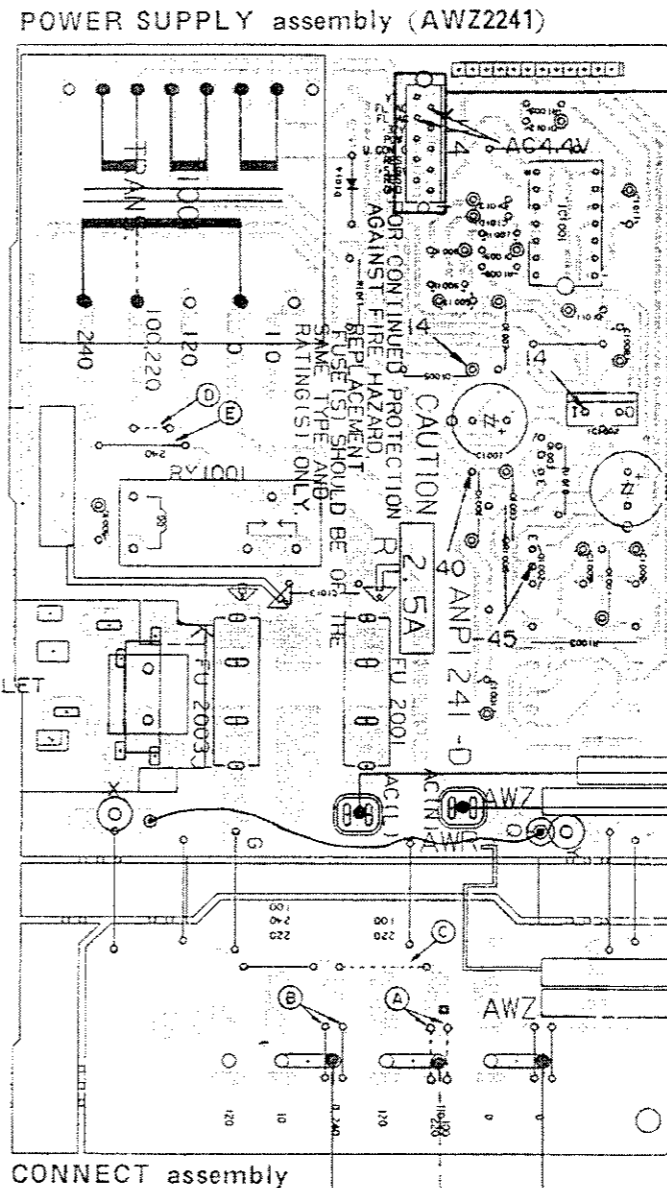

AC OUTLET

CONNECT assembly

To AF assembly CN14
(To page 43)

AC POWER CORD
AC240V
50/60Hz

T2001
POWER TRANSFORMER

Stick the line voltage label on the rear panel.

Part No.	Description
AAX-193	220V label
AAX-192	240V label

To AF assembly J13
(To page 43)

- NOTE
1. This P.C.B. connection
 2. The parts which have with the corresponding

P.C.B. pattern diagram in

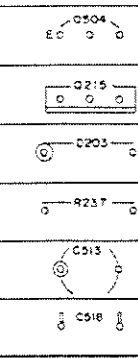

Others

P.C.B. pattern diagram in

Component	Location
IC	
S	
RY	
L	
F	
VR	

3. The capacitor terminal
4. The diode terminal
5. The transistor terminal

NOTE

- 1. This P.C.B. connection diagram is viewed from the parts mounted side.
- 2. The parts which have been mounted on the board can be replaced with those shown with the corresponding wiring symbols listed in the following Table.

P.C.B. pattern diagram indication	Corresponding part symbol	Part Name
		Transistor
		Radiator type transistor
		Diode
		Resistor
		Capacitor (Polarity)
		Capacitor (Non polarity)

Others

P.C.B. pattern diagram indication	Part Name
IC	IC
S	Switch
RY	Relay
L	Coil
F	Filter
VR	Variable resistor or Semi-fixed resistor

- 3. The capacitor terminal marked with ⊕ (double circles) shows negative terminal.
- 4. The diode terminal marked with ⊕ (double circles) shows cathode side.
- 5. The transistor terminal to which E is affixed shows the emitter.

NOTE:

This picture shows the foil side of the printed circuit.

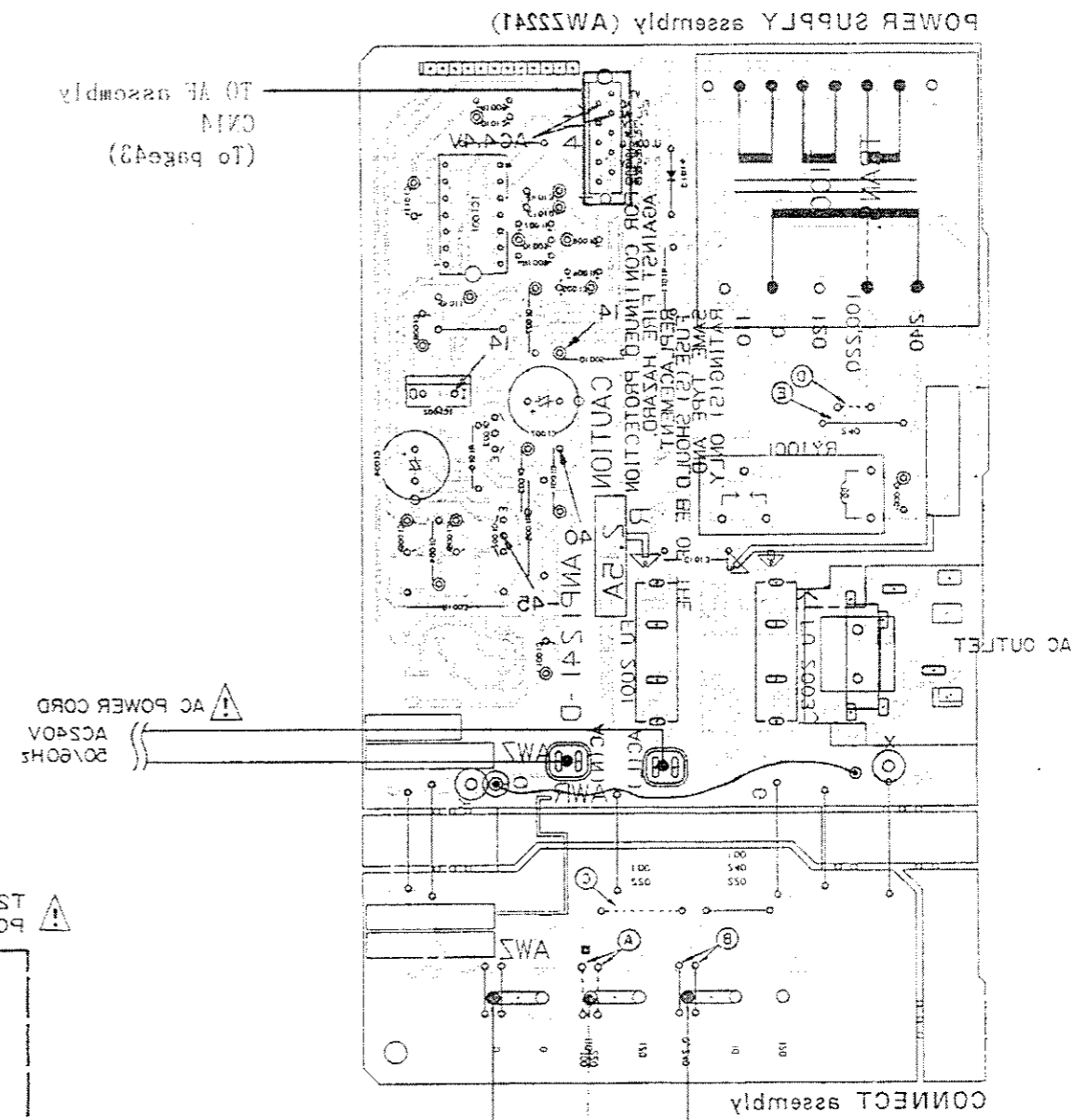

A

B

C

D

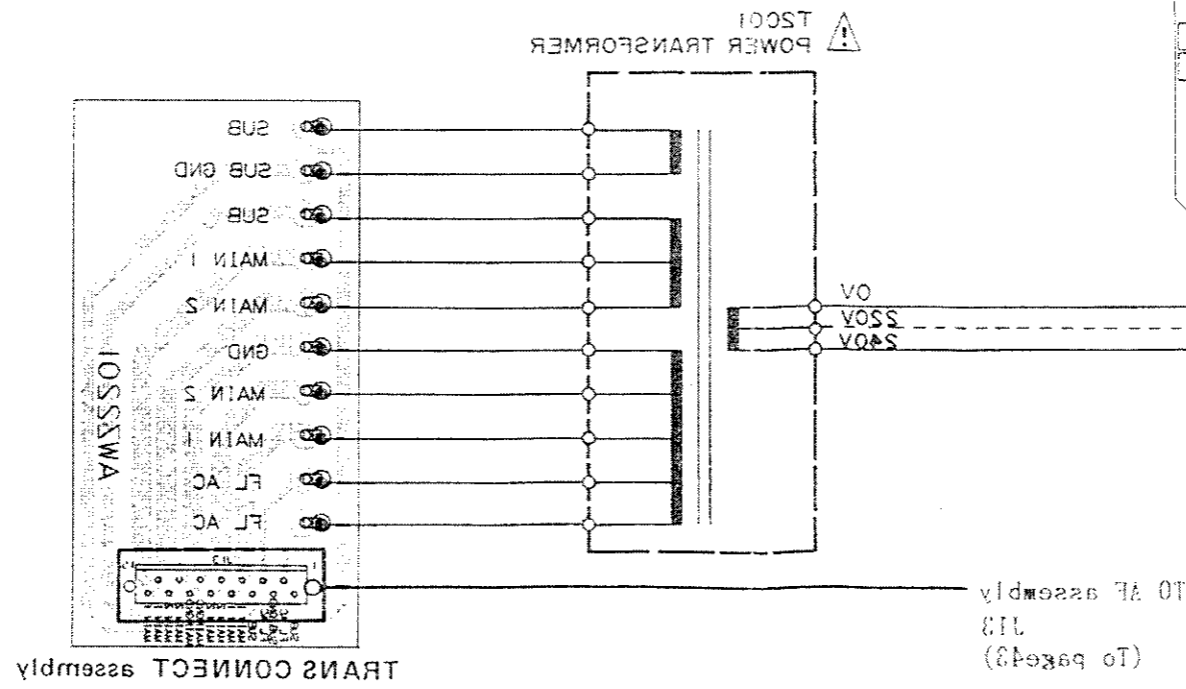
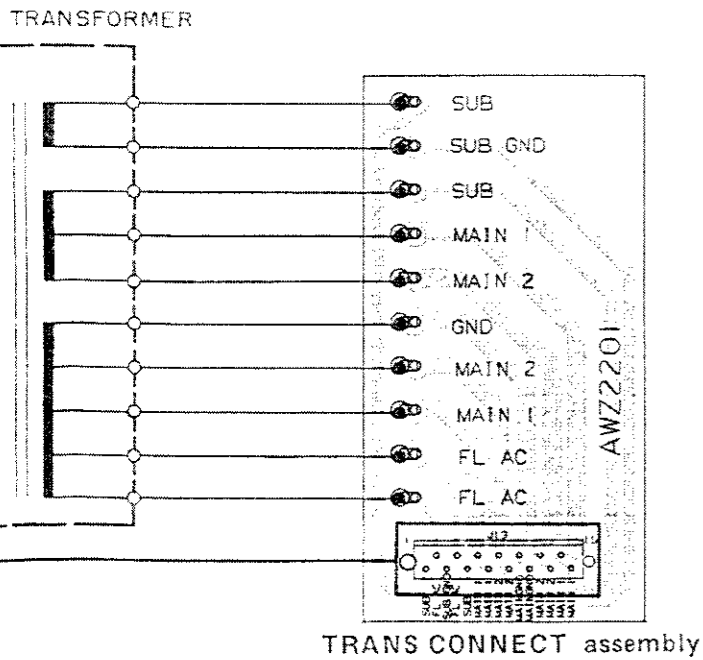

5. ELECTRICAL PARTS LIST

NOTES:

- Parts without part number cannot be supplied.
- Parts marked by "⊙" are not always kept in stock. Their delivery time may be longer than usual or they may be unavailable.
- The Δ mark found on some component parts indicates the importance of the safety factor of the part. Therefore, when replacing, be sure to use parts of identical designation.
- When ordering resistors, first convert resistance values into code form as shown in the following examples.

Ex. 1 When there are 2 effective digits (any digit apart from 0), such as 560 ohm and 47k ohm (tolerance is shown by J = 5%, and K = 10%).

560 Ω	56×10^1	561.....	RD1/4PS	\square	\square	\square	J
47k Ω	47×10^3	473.....	RD1/4PS	\square	\square	\square	J
0.5 Ω	0R5.....		RN2H	\square	\square	\square	K
1 Ω	010.....		RS1P	\square	\square	\square	K

Ex. 2 When there are 3 effective digits (such as in high precision metal film resistors).

5.62k Ω	562×10^1	5621.....	RN1/4SR	\square	\square	\square	F
----------------	-------------------	-----------	---------	-----------	-----------	-----------	---

Miscellaneous Parts

P.C.BOARD ASSEMBLIES

Mark	Symbol & Description	Part No.
	FUNCTION assembly	AWK1174
	MIC BALANCE assembly	
	AF assembly	AWZ2204
	MAIN VR assembly	
	HEAD PHONE assembly	
	TRANS CONNECT assembly	
	AMP,GEQ CTRL assembly	AWZ2056
	DECK-1 SW assembly	
	DECK-2 SW assembly	
	DECK CTRL assembly	AWZ2319

Note: The GEQ assembly (AWG1016) and the REC assembly (AWK1178) are some of the parts for the AF assembly (AWZ2204).

	GEQ assembly	AWG1016
	REC assembly	AWK1178

	DECK CENTER assembly	
	POWER SUPPLY assembly	AWZ2241
	CONNECT assembly	

OTHERS

Mark	Symbol & Description	Part No.
Δ	T2001 Power Transformer (AC220V/240V)	ATS1184
Δ	FU2004,FU2005 Fuse (1.25A/250V)	AEK-509
Δ	FU2003 Fuse (T1.6A/250V)	AEK-510
Δ	FU2001 Fuse (T2A/250V)	AEK-511
Δ	AC Power cord	ADG-063
	Hall IC	AZE1018
	Leaf SW	AZS1054
	Leaf SW	AZS1034
	P.C. BOARD	AZN1836
	Bobbin	AZS1035

Mark	Symbol & Description	Part No.
	Bobbin	AZS1036
	Motor assembly	AZX1020
	R/P E Head	AZP1014
	Head frame assembly	AZP1016

FUNCTION assembly (AWK1174)

SEMICONDUCTORS

Mark	Symbol & Description	Part No.
	IC901,IC904	NJM4558DXP
	IC902	TC4052BP
	IC903	TC4066BP
	Q901,Q903	DTA143ES
	Q902	DTC143ES
	D901	HSS104-02

CAPACITORS

Mark	Symbol & Description	Part No.
	C903-C906,C929,C930	CCCSL101J50
	C907,C908	CEAS2R2M50
	C909,C910	CKCYB152K50
	C911,C912	CKCYB562K50
	C913,C914	CEAS470M10
	C919,C920,C931,C932	CEAS100M25

RESISTORS

Mark	Symbol & Description	Part No.
	All resistors	RD1/BPM□□□J

OTHERS

Mark	Symbol & Description	Part No.
	Terminal 4P (CD, VIDEO IN)	AKB1009
	Terminal 4P (PHONO, VIDEO OUT)	AKB1085

MIC BALANCE assembly
SEMICONDUCTORS

Mark	Symbol & Description	Part No.
	IC371	NJM4558DXP
	Q372	2SA1048
	Q371	2SC2878
	D371,D372	HSS104-02

CAPACITORS

Mark	Symbol & Description	Part No.
	C376	ACG1019
	C372	CEAS010M50
	C375,C377,C378	CEAS100M25
	C371,C379,C380	CKCYF473Z50
	C373	CKMYB681K50

RESISTORS

Mark	Symbol & Description	Part No.
	VR371	ACS1025
	VR372	ACS1029
	Other resistors	RD1/8PM□□□J

OTHERS

Mark	Symbol & Description	Part No.
	Mic jack	AKN1017

AF assembly (AWZ2204)

SEMICONDUCTORS

Mark	Symbol & Description	Part No.
	IC471	HA12138
	IC306	ICP-N38
	IC301,IC304	MC7812CT
	IC523	M74LS05P
	IC311,IC321,IC431,IC501,IC522	NJM4558DXP
	IC302	NJM78M05FA
	IC303	NJM79M05FA
	IC331	STK4192-2GP
	IC332	TA7291S
	IC412,IC521	TC4066BP
	Q578	RN1201
	Q354,Q527,Q528,Q570,Q573	RN1203
	Q575-577	
	Q571,Q572,Q579	RN2203
	Q321,Q355,Q483,Q580	2SA1048

Mark	Symbol & Description	Part No.
	Q581,Q582	2SA1515
	Q493,Q494	2SC1740SLN
	Q353	2SC2240
	Q351,Q352,Q356,Q411,Q412	2SC2458
	Q431-438,Q481,Q482,Q491	
	Q492,Q521,Q522	
	Q583,Q584	2SC2603
	Q523,Q524	2SC2878
	Q322	2SK246
	Q413,Q414	2SK373
	D321,D351,D352,D411-D416	HSS104-02
	D491,D492,D571-579	
	D301	RBV402
	D309 Zener Diode	RD5.6ESB
	D310 Zener Diode	RD7.5ESB
	D302-D308,311	S5566

COILS & TRANSFORMER

Mark	Symbol & Description	Part No.
	F491,F492	ATF1064
	L351,L352 (1mH)	ATH-133
	L521,L522	ATM-037
	L451,L452	ATM1001
	T581	ATX-043
	L523,L524 Inductor (3.9mH)	LTA392J

RELAY

Mark	Symbol & Description	Part No.
	RY351	ASR1005

CAPACITORS

Mark	Symbol & Description	Part No.
	C588 (2000p)	ACE1020
	C301,C302 (2200/42)	ACH-252
	C1611,C1612	CCCSL101J50
	C417,C418	CCCSL101K500
	C421,C422	CCMSL100D50
	C343	CEANP100M50
	C341	CEANP220M50
	C345	CEANP470M50
	C473,C474	CEASR22M50
	C495	CEASR33M50
	C323,C324,C437-C440,C491	CEAS010M50
	C492,C521-C524	
	C312,C313,C342,C344,C352	CEAS100M50
	C471,C472,C493,C494,C496	
	C475,C476	CEAS101M10
	C593	CEAS101M16
	C339,C340	CEAS101M25
	C304,C305	CEAS102M25
	C331,C531,C532	CEAS2R2M50
	C571	CEAS220M16

Mark	Symbol & Description	Part No.
	C307 - C310, C478 C351, C572, C573 C303 C433, C434, C525, C526 C591	CEAS220M25 CEAS221M10 CEAS222M25 CEAS330M16 CEAS4R7M50
	C435, C436 C545, C546, C570, C581 C335, C337, C338 C332 C336	CEAS470M10 CEAS470M16 CEAS470M50 CEHAQ2R2M50 CEHAQ470M50
	C527, C528 C315, C346 C587 C411, C412 C413, C414	CFTXA683J50 CKDYF473Z50 CKMYB221K50 CKMYB331K50 CKMYB471K50
	C325, C533, C534, C586 C415, C416 C582, C584 C347 - C350 C585	CKMYB681K50 CKMYB821K50 CQMA103K50 CQMA104K50 CQMA123K250
	C583 C528, C530 C535, C536 C541, C542 C316	CQMA153K50 CQMA182J50 CQMA183J50 CQMA473J50 CQMA473K250
	C539, C540 C590 C431, C432 C537, C538 C543, C544	CQMA562J50 CQMA562K400 CQMA682J50 CQMA752J50 CQMA823J50
	C321, C322	CQSA471J50

RESISTORS

Mark	Symbol & Description	Part No.
	VR451, VR452 (100k) VR453, 454 (20k) VR521, VR522 (20k) VR411, VR412 (200k)	VRTM6H104 VRTM6H203 VRTM6V203 VRTM6V204
	R589, 590 R342, R345, R350 - R352 R348, R349 R301 - R306, R337 - R340, R343 R344	RD1/2PM□□□J RD1/4PMFL□□□J RD1/4PMF100J RD1/4PM□□□
	R341 R307, R308, R364	RFA1/4PL471J RS2LMF□□□J
	Other resistors	RD1/8PM□□□J

OTHERS

Mark	Symbol & Description	Part No.
	Terminal 2P (REAR SPEAKER) Speaker terminal 4P DC Jack GEQ assembly REC assembly	AKB1039 AKE1012 AKN - 203 AWG1016 AWK1178

GEQ Ass'y (AWG1016)

Note: This GEQ assembly (AWZ1016) is a part of AF assembly (AWZ2204).

SEMICONDUCTORS

Mark	Symbol & Description	Part No.
	IC601, IC602 IC603 IC604	LA3607 LC7522 M5218L
	Q609 Q601 Q603 Q606 Q602, Q607, Q608	DTA124ES DTC143ES RN2204 2SA1515 2SC2458
	Q604, Q605	2SC2603
	D601, D602, D605 D603 Zener Diode D604 Zener Diode	HSS104-02 HZS5ALL HZS7B2L

CAPACITORS

Mark	Symbol & Description	Part No.
	C638 C640 C601, C602, C607, C608 C603, C604 C641	CCCSL101J50 CCCSL560J50 CEASR15M50 CEASR47M50 CEAS0R1M50
	C639 C643 C644, C645 C631 - C634 C642	CEAS010M50 CEAS100M25 CEAS101M10 CEAS2R2M50 CEAS331M16
	C621, C622, C627, C628 C613, C614, C619, C620 C617, C618, C623, C624 C629, C630 C635 - C637	CGMYB182M50 CGMYX103M16 CGMYX472M25 CKCYB331K50 CKCYF473Z50
	C609, C610, C615, C616 C605, C606, C611, C612 C625, C626	CKCYX273M25 CKCYX683M25 CKMYB681K50

RESISTORS

Mark	Symbol & Description	Part No.
	R609, R610 Other resistors	RA8T105J RD1/8PM□□□J

REC assembly (AWK1178)

Note: This REC assembly (AWK1178) is a part of AF assembly (AWZ2204).

SEMICONDUCTOR

Mark	Symbol & Description	Part No.
	IC1401	NJM4558DXP
	Q1045 - Q1408, Q1413, Q1419, Q1421	RN1203
	Q1420	RN2203
	Q1414	2SA1115
	Q1415, Q1416	2SA1515
	Q1411, Q1412	2SC2458
	Q1417, Q1418	2SC2603
	Q1401 - Q1404	2SC2878
	Q1409, Q1410	2SK373
	D1401 - D1409	HSS104-02

COILS & TRANSFORMERS

Mark	Symbol & Description	Part No.
	L1401, L1402	ATM-037
	L1403, L1404	LTA392J
	T1401	ATX-043

CAPACITORS

Mark	Symbol & Description	Part No.
	C1431	ACE1020
	C1425	CCCSL221J50
	C1421, C1422	CCMSL100D50
	C1401, C1402	CEAS010M50
	C1439	CEAS101M16
	C1417, C1418	CEAS2R2M50
	C1437, C1438	CEAS3R3M50
	C1403, C1404	CEAS330M50
	C1436	CEAS4R7M50
	C1415, C1416	CEAS470M10
	C1423, C1424	CEAS470M16
	C1434, C1435	CKCYB471K500
	C1419, C1420, C1427	CKMYB681K50
	C1428, C1429	CQMA103J50
	C1430	CQMA123K250
	C1426	CQMA153J50
	C1412, C1413	CQMA182J50
	C1407, C1408	CQMA183J50
	C1433	CQMA272K400
	C1405, C1406	CQMA333J50
	C1409, C1410	CQMA393J50
	C1432	CQMA562K400
	C1411, C1414	CQMA683J50

RESISTORS

Mark	Symbol & Description	Part No.
	R1443, R1444	RD1/2PM□□□J
	VR1401, VR1402	VRTM6H203
	VR1403, VR1404	VRTM6H204
	Other resistors	RD1/8PM□□□J

MAIN VR assembly SEMICONDUCTORS

Mark	Symbol & Description	Part No.
	IC391	NJM4558DXP
	Q393	2SA1048
	Q391, Q392	2SC2878

COILS

Mark	Symbol & Description	Part No.
	L391, L392 Axial Inductor (5.6μH)	LAU5R6K

CAPACITORS

Mark	Symbol & Description	Part No.
	C393, C394	CCMSL101J50
	C391, C392	CEAS4R7M50
	C397, C398	CEAS470M10
	C395, C396	CKCYF473Z50

RESISTORS

Mark	Symbol & Description	Part No.
	VR391	ACX1021
	Other resistors	RD1/8PM□□□J

HEAD PHONE assembly

CAPACITORS

Mark	Symbol & Description	Part No.
	C401	CKCYF473Z50

RESISTORS

Mark	Symbol & Description	Part No.
	R402 - R405	RD1/2PMF681J
	R401	RD1/8PM100J

OTHERS

Mark	Symbol & Description	Part No.
	Head phone Jack	AKN1010

TRANS CONNECT assembly

No parts are supplied with the TRANS CONNECT assembly.

AMP.GEQ CTRL assembly (AWZ2056) SEMICONDUCTORS

Mark	Symbol & Description	Part No.
	IC701, IC702	M74LS05P
	IC721 - IC725, IC727	NJM4558DXP
	IC771	PD3133
	IC726	TC4051BP
	IC703	TC4081BP

Mark	Symbol & Description	Part No.
	Q701,Q702	DTA143ES
	Q721-Q729	DTC143ES
	Q730	2SA1048
	Q731-Q733	2SC2458
	D703,D705,D707,D709,D711	AEL1065
	D713,D715	AEL1081
	D721-D728,D771-D780,D782	HSS104-02
	D785,D786	

COILS

Mark	Symbol & Description	Part No.
	X771 Ceramic resonator	ASS1018
	L771 Axial inductor (22 μ H)	LAU220K

SWITCHES

Mark	Symbol & Description	Part No.
	S701,S703,S705,S707,S709, S711,S715,S717,S771-S793 Tact switch (SURROUND, CD, PHONO, TUNER, TAPE, DAT, CD DIRECT, POWER, 60Hz+, 150Hz+, 400Hz+, 1kHz+, 2.4kHz+, 6kHz+, 15kHz+, 60Hz-, 150Hz-, 400Hz-, 1kHz-, 2.4kHz-, 6kHz-, 15kHz-, A, B, C, D, E, PRESET/MEMORY, EQUALIZER ON/OFF, FLAT/REVERSE, MEMORY)	ASG1029

CAPACITORS

Mark	Symbol & Description	Part No.
	C773 (0.047)	ACH1070
	C775	CKCYB102K50
	C729,C730	CKCYB182K50
	C733,C734	CKCYB331K50
	C727,C728	CKCYB472K50
	C731,C732	CKCYB821K50
	C725,C726	CKCYX123M25
	C723,C724	CKCYX333M25
	C735-C741,C771,C772,C774, C776	CKDYF473Z50
	C721,C722	CKDYX823M25

RESISTORS

Mark	Symbol & Description	Part No.
	All resistors	RD1/8PM□□□J

OTHERS

Mark	Symbol & Description	Part No.
	V772 Fluorescent indicator tube	AAV1069
	V771 Fluorescent indicator tube	AAV1071

DECK - 1 SW assembly

SWITCHES

Mark	Symbol & Description	Part No.
	S811-S815 Tact switch (1FWD, 1REV, 1FF, 1REW, 1STOP)	ASG1029

DECK - 2 SW assembly

SWITCHES

Mark	Symbol & Description	Part No.
	S821-S825 Tact switch (2FWD, 2REV, 2FF, 2REW, 2STOP)	ASG1029

DECK CTRL assembly (AWZ2319)

SEMICONDUCTORS

Mark	Symbol & Description	Part No.
	IC802	M74LS42P
	IC801	PDE029-C
	Q813-815	DTC143ES
	Q803-806	RN1201
	Q801,802	RN2204
	Q807-812	2SA1515
	Q816	RN2203
	D801,D802,D807-D816	HSS104-02
	D820-D826,D833-D836	
	D751,D752,D754	

COILS

Mark	Symbol & Description	Part No.
	X801 Ceramic resonator	ASS1018
	L801 Axial inductor (22 μ H)	LAU220K

CAPACITORS

Mark	Symbol & Description	Part No.
	C801	CEASR33M50
	C803	CEAS101M10
	C802	CEAS101M16
	C839,C840	CKDYB102K50
	C804-C807	CKDYF473Z50

RESISTORS

Mark	Symbol & Description	Part No.
	VR803 (10k)	VRTM6H103
	VR801,VR802 (20k)	VRTM6H203
	R899	RD1/2PM1R8J
	Other resistors	RD1/8PM□□□J

DECK CENTER assembly

SEMICONDUCTORS

Mark	Symbol & Description	Part No.
	D848 LED	AEL1025
	D869 LED	AEL1033
	D845, D846 LED	AEL1075
	D841-D844 LED	AEL1076
	D850-D853 LED	AEL1094
	D854-D859	HSS104-02

SWITCHES & RELAYS

Mark	Symbol & Description	Part No.
	S860 Tact switch (DECK-1 PAUSE, DECK-2, MUTE, DECK-1 MUTE, COPY, DECK-2 PAUSE, PARA ASES, PARA REC, FADER, DECK-2 REC, RELAY ASES, ASES, HI-SPEED COPY, RELAY REC, DECK-1 REC)	ASG-711
	S851-S859, S861-864 Tact switch	ASG1029
	S848, S849 Slide switch (DOLBY, REVERSE MODE)	ASH1014

RESISTORS

Mark	Symbol & Description	Part No.
	All resistors	RD1/8PM□□□J

POWER SUPPLY assembly (AWZ2241)

SEMICONDUCTORS

Mark	Symbol & Description	Part No.
	IC1002	NJM78M56FA
	IC1001	TC4069UBP
	Q1002	2S8560
	Q1003	2SC2240
	D1006, D1008, D1011-D1013	HSS104-02
	D1004 Zener Diode	RD33ESB2
	D1009 Zener Diode	RD5.1ESB
	D1001, D1003, D1005, D1007, D1014	S5566

TRANSFORMER

Mark	Symbol & Description	Part No.
△	T1001 Power transformer	ATT1092

RELAY

Mark	Symbol & Description	Part No.
△	RY1001 Relay	ASR1024

CAPACITORS

Mark	Symbol & Description	Part No.
	C1009, C1010	CEAS100M50
	C1005	CEHAQ220M50
	C1004	CEAS221M50
	C1007	CEAS222M16
	C1011	CEAS4R7M50
	C1008	CEAS470M16
	C1006	CEAS470M50
	C1001	CEAS470M63

RESISTORS

Mark	Symbol & Description	Part No.
	R1011	RD1/4PMFL4R7J
	R1003	RS2LMF222J
	R1005	RS2LMF821J
	Other resistors	RD1/8PM□□□J

OTHERS

Mark	Symbol & Description	Part No.
△	1P AC SOCKET (OUTLET)	AKP1035

CONNECT assembly

No parts are supplied with the connection assembly.

6. ADJUSTMENTS

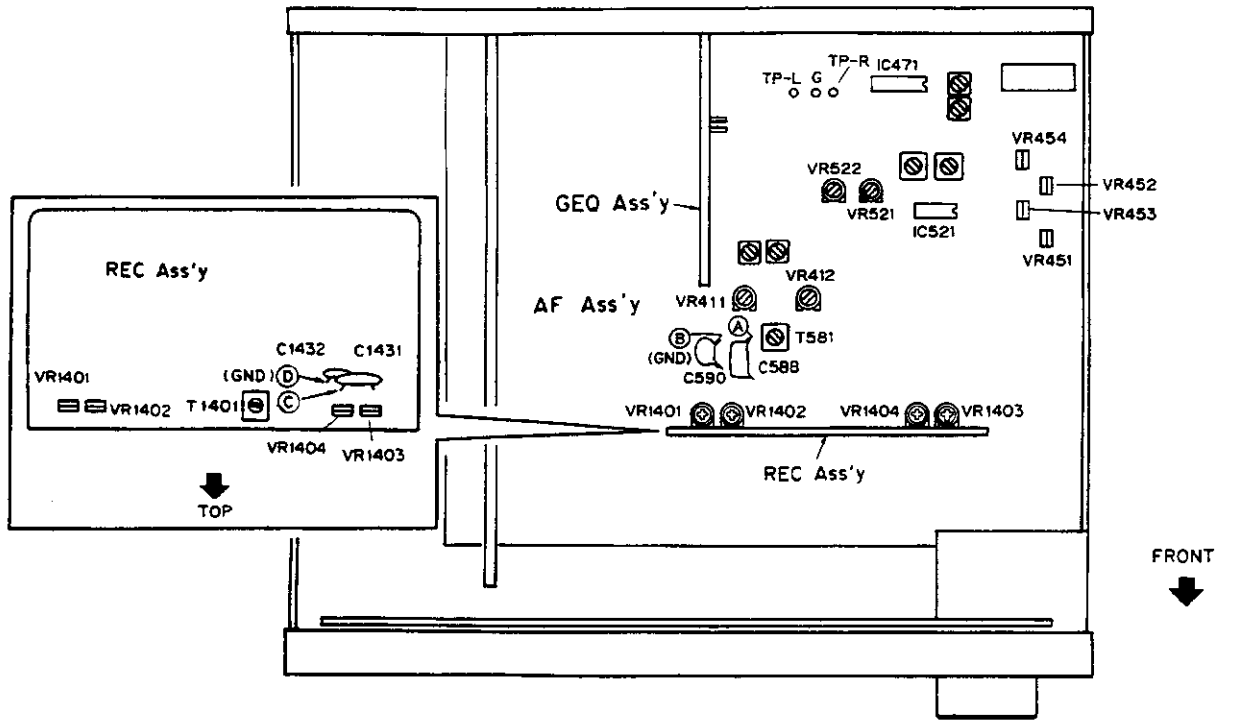

Fig 6.1. Adjustment location

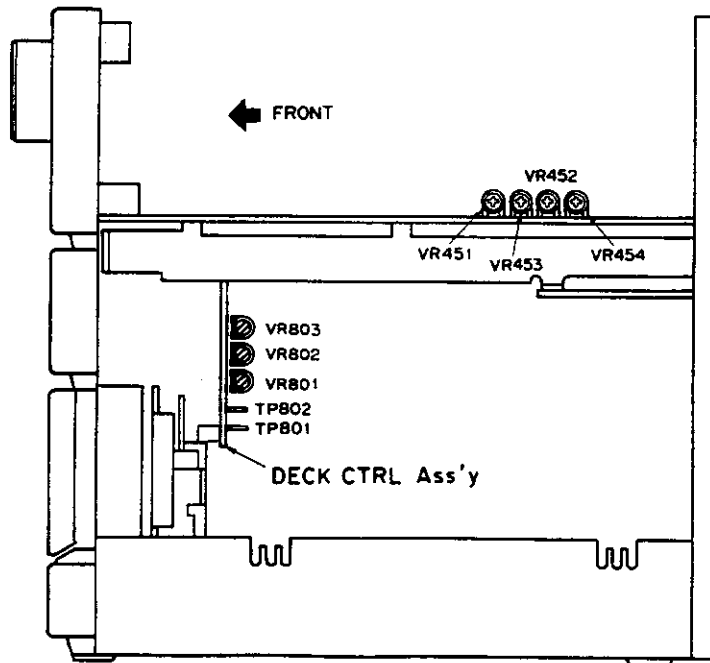

Fig 6.2. Adjustment location

- Adjustment and measurement are usually made in the AF Ass'y, unless specified otherwise.
- Set the graphic equalizer to OFF, the balance control to Center and the microphone mixing volume to MIN.
- The function should always be set to "TAPE" unless otherwise specified.

Adjustment of Mechanical System

- Test tape: STD-301 (3 kHz, 30 min)
- Setting of double speed mode: Short-circuit TP801 and TP802 of the DECK CTRL Ass'y. To release the mode, break the short circuit.

1. Adjustment of tape speed							
No.	Mode	Input signal & Test tape	Adjustment location		Measuring location	Adjustment value	Remarks
1	PLAY	Playback the STD-301 tape to 3 kHz.	Deck I	DECK CTRL Ass'y VR801	TP-L (Lch)	Press the PLAY SW and adjust the frequency to 3010 Hz \pm 10 Hz. Make sure that the wow and flutter is within 0.2 %.	
2	PLAY (Double speed mode)			—		Press the PLAY SW in double speed mode and confirm that the frequency is 6000 Hz \pm 1000 Hz. Note down the figure.	Release the double speed mode after adjustment.
3	PLAY (Double speed mode)		Deck II	DECK CTRL Ass'y VR803	TP-R (Rch)	Press the PLAY SW in double speed mode and adjust the frequency to be within \pm 30 Hz of the figure recorded at step No. 2.	Release the double speed mode after adjustment.
4	PLAY			DECK CTRL Ass'y VR802		Press the PLAY SW and adjust the frequency to 3010 Hz \pm 10 Hz. Make sure that the wow and flutter is within 0.2 %.	

Adjustment of Electric System

■ Check and conduct the following before adjusting the electric system.

1. Adjustment of tape speed has been completed.
2. Clean and demagnetize the head using a head eraser.
3. When measured, the level should be 0 dBV = 1 Vrms.
4. Use side A of the specified tape for adjustment.
STD-331B: For adjustment of playback system.
STD-630: NORMAL blank tape
STD-620: CrO₂ blank tape
STD-610: METAL blank tape
5. Prepare the following measuring devices:
AC millivoltmeter, Low-frequency oscillator, Attenuator, Oscilloscope
6. Adjust both L and R channels, unless specified otherwise.
7. Set the DOLBY NR switches to OFF, unless specified otherwise.

8. Warm up the unit for several minutes before adjustment. Especially before adjusting the frequency characteristics of recording and playback, warm up for 3 to 5 minutes in REC/PLAY mode.
9. Make sure to follow the proper order of the adjustment procedure. Any change in the order may cause an imperfect result.

List of Adjustment

Deck I

1. Head azimuth adjustment
2. Playback level adjustment
3. Adjustment frequency characteristics of recording/playback
4. Recording level adjustment

Deck II

1. Head azimuth adjustment
2. Playback level adjustment
3. Adjustment frequency characteristics of recording/playback
4. Recording level adjustment

Checking of Decks I and II

1. Make sure the ALC is operating properly.

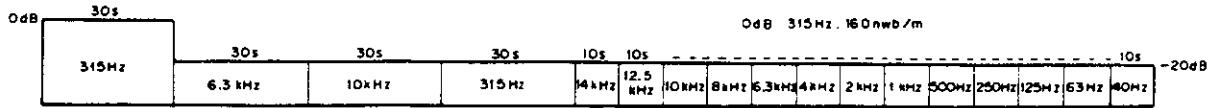

Fig. 6.3 Test tape STD-331B

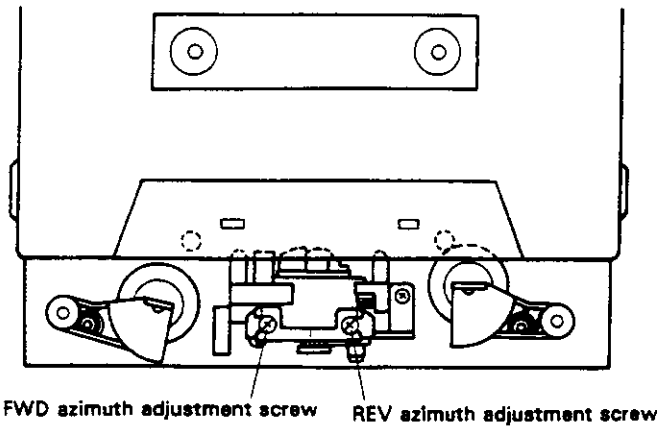

Fig. 6.4 Head azimuth adjustment

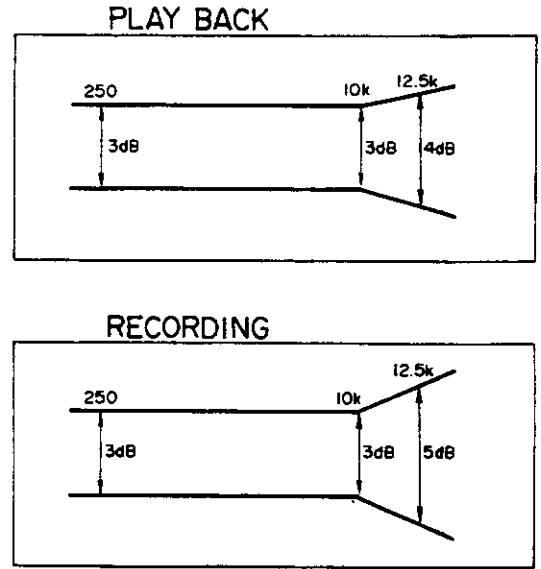

Fig. 6.5 Frequency characteristics

• Head Adjustment of Deck I

- Deck I is provided with an automatic tape selector mechanism.
- Note: Do not switch over FWD and REV while the driver is inserted.

1. Head Azimuth Adjustment

Procedure	Tape selector	Mode	Input signal/test tape	Adjustment location	Measuring location	Adjustment value	Remarks
1	NORM	PLAY	Playback the test tape STD-331B (10 kHz, -20 dB).	Head azimuth adjustment screw (Fig. 6-4)	TP-L (Lch) TP-R (Rch)	Maximum playback signal level	Lock the screw with screw lock after completing adjustment.

2. Playback Level Adjustment

- Be sure to make a careful adjustment, as the adjustment determines the DOLBY NR level for playback.

Procedure	Tape selector	Mode	Input signal/test tape	Adjustment location	Measuring location	Adjustment value	Remarks
1	NORM	PLAY	Playback the test tape STD-331B (315 Hz, 0 dB).	VR453 (Lch) VR454 (Rch)	TP-L (Lch) TP-R (Rch)	-6.7 dBV	

3. Adjustment of frequency characteristics of recording/playback

- As this procedure is for adjustment of the recording bias, be careful not to increase the distortion by under-adjusting the bias.

Procedure	Tape selector	Mode	Input signal/test tape	Adjustment location	Measuring location	Adjustment value	Remarks
1	NORM	REC	Load the test tape STD-630 and set to record mode.	—	Area between ③ and ④ (REC Ass'y) shown in Fig. 6-1.	Confirm that the oscillation frequency is 105 kHz \pm 1 kHz.	If the adjustment value cannot be set within the specification, adjust the T1401 of the REC Ass'y.
2	NORM	REC	Apply a signal of 315 Hz to the CD input terminal and set the function to "CD".	Input signal level	TP-L (Lch) TP-R (Rch)	-27.7 dBV	
3	NORM	REC/ PLAY	Record and playback the test tape STD-630 (315 Hz and 10 kHz).	REC Ass'y VR1403 (Lch) VR1404 (Rch)	TP-L (Lch) TP-R (Rch)	Repeat the correction so that the playback level of 10 kHz remains 0 \pm 0.5 dB in relation to 315 Hz.	

4. Recording Level Adjustment

Procedure	Tape selector	Mode	Input signal/test tape	Adjustment location	Measuring location	Adjustment value	Remarks
1	NORM	REC	Apply a signal of 315 Hz to the CD input terminal and set the function to "CD".	Input signal level	TP-L (Lch) TP-R (Rch)	-7.7 dBV	
2	NORM	REC/ PLAY	Record and playback the test tape STD-630 (315 Hz and 10 kHz).	REC Ass'y VR1401 (Lch) VR1402 (Rch)	TP-L (Lch) TP-R (Rch)	Repeat the recording and correction so that the playback level of 315 Hz is -6.7 dBV.	

- **Head Adjustment of Deck II**
- Deck II is provided with an automatic tape selector mechanism.
- Note: Do not switch over FWD and REV while the driver is inserted.

1. Head Azimuth Adjustment

Pro-cedure	Tape selector	Mode	Input signal/test tape	Adjustment location	Measuring location	Adjustment value	Remarks
1	NORM	PLAY	Playback the test tape STD-331B (10 kHz, -20 dB).	Head azimuth adjustment screw (Fig. 6-4)	TP-L (Lch) TP-R (Rch)	Maximum playback signal level	Lock the screw with screw lock after completing adjustment.

2. Playback Level Adjustment

- Be sure to make a careful adjustment, as the adjustment determines the DOLBY NR level for playback.

Pro-cedure	Tape selector	Mode	Input signal/test tape	Adjustment location	Measuring location	Adjustment value	Remarks
1	NORM	PLAY	Playback the test tape STD-331B (315 Hz, 0 dB).	VR451 (Lch) VR452 (Rch)	TP-L (Lch) TP-R (Rch)	-6.7 dBV	

3. Adjustment of frequency characteristics of recording/playback

- As this procedure is for adjustment of the recording bias, be careful not to increase the distortion by under-adjusting the bias.

Pro-cedure	Tape selector	Mode	Input signal/test tape	Adjustment location	Measuring location	Adjustment value	Remarks
1	NORM	REC	Load the test tape STD-630 and set to record mode.	—	Area between ① and ② (AF Ass'y) shown in Fig. 6-1.	Confirm that the oscillation frequency is 105 kHz \pm 1 kHz.	If the adjustment value cannot be set within the specification, adjust the T581.
2	NORM	REC	Apply a signal of 315 Hz to the CD input terminal and set the function to "CD".	Input signal level	TP-L (Lch) TP-R (Rch)	-27.7 dBV	
3	NORM	REC/ PLAY	Record and playback the test tape STD-630 (315 Hz and 10 kHz).	VR411 (Lch) VR412 (Rch)	TP-L (Lch) TP-R (Rch)	Repeat the correction so that the playback level of 10 kHz remains 0 \pm 0.5 dB in relation to 315 Hz.	

4. Recording Level Adjustment

Pro-cedure	Tape selector	Mode	Input signal/test tape	Adjustment location	Measuring location	Adjustment value	Remarks
1	NORM	REC	Apply a signal of 315 Hz to the CD input terminal and set the function to "CD".	Input signal level	TP-L (Lch) TP-R (Rch)	-7.7 dBV	
2	NORM	REC/ PLAY	Record and playback the test tape STD-630 (315 Hz).	VR521 (Lch) VR522 (Rch)	TP-L (Lch) TP-R (Rch)	Repeat the recording and correction so that the playback level of 315 Hz is -6.7 dBV.	

• Checking Procedure for Decks I and II

1. Action of ALC

Pro-cedure	Tape selector	Mode	Input signal/test tape	Adjustment location	Measuring location	Checking value	Remarks
1	NORM	REC	Apply a signal of 315 Hz to the CD input terminal and set the function to "CD".	Input signal level	TP-L (Lch) TP-R (Rch)	-7.7 dBV	
2				+10 dB against the input level of step 1.		-2.7 dBV \pm 2.5 dB	

6. RÉGLAGES

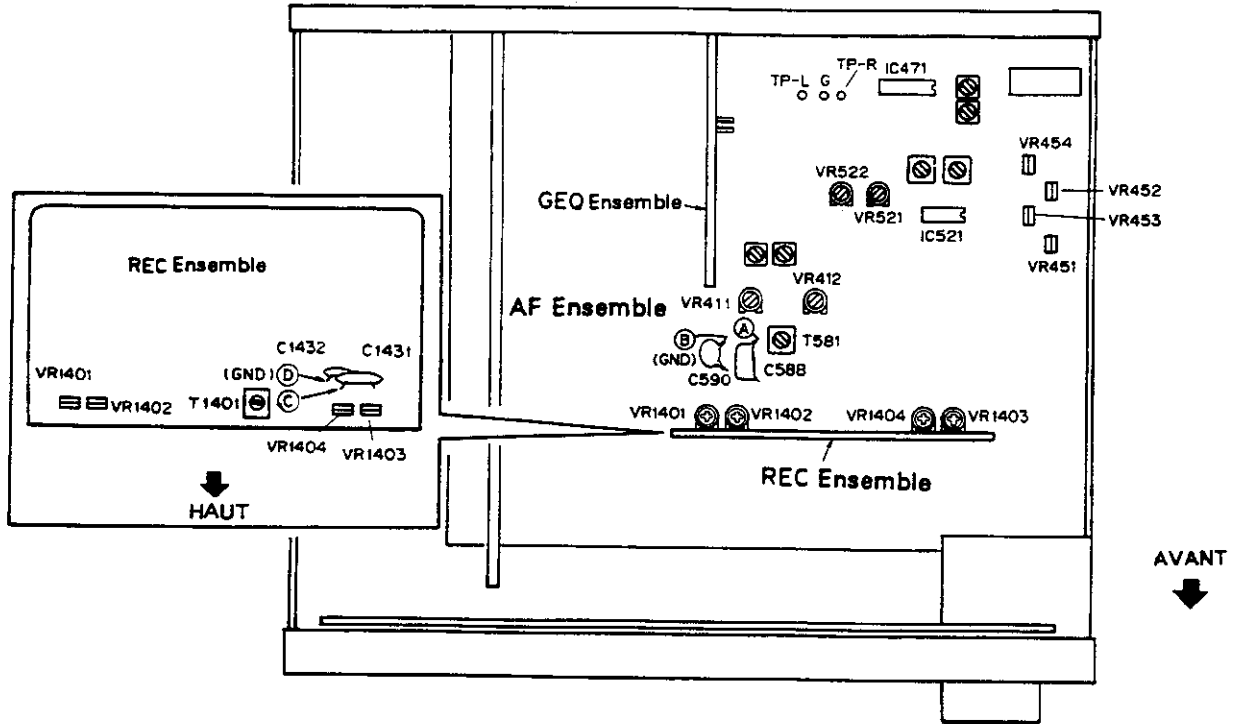

Fig 6.1 Points de réglage

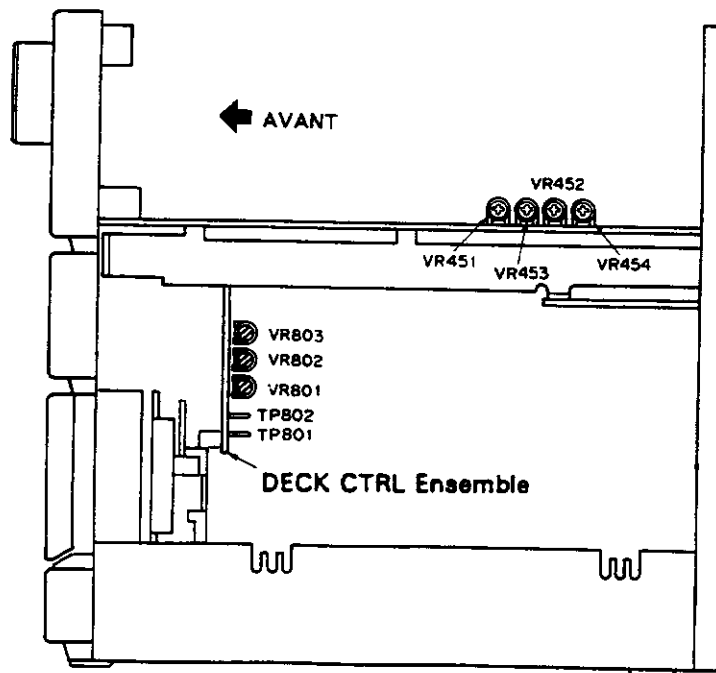

Fig 6.2 Points de réglage

- Les réglages et les mesures sont généralement faits dans l'ensemble AF, à moins de spécification contraire.
- Régler l'égaliseur graphique sur OFF, la commande d'équilibre en position centrale et le volume de mixage au microphone sur MIN.
- La fonction doit toujours être réglée sur "TAPE" à moins de spécification contraire.

Réglages mécaniques

- Bande d'étalonnage: STD-301 (3 kHz, 30 mn.)
- Réglage du mode de vitesse double: Court-circuiter TP801 et TP802 de l'ensemble de commande. Pour libérer le mode, ouvrir le court-circuit.

1. Réglage de la vitesse de bande							
No.	Mode	Signal appliqué / bande d'étalonnage	Emplacement du réglage		Emplacement du point de mesure	Valeur relevée	Observations
1	PLAY	Reproduire la bande STD-301 par 3 kHz.	Platine I	ENSEMBLE COMM. PLATINE VR801	TP-L (can. G)	Appuyer sur le contacteur PLAY et régler la fréquence sur 3.010 Hz \pm 10 Hz. Vérifier que le pleurage et scintillement est dans la limite de 0,2%.	
2	PLAY (Mode de vitesse double)			—		Appuyer sur le contacteur PLAY dans le mode de vitesse double et vérifier que la fréquence est 6.000 Hz \pm 1.000 Hz. Noter le chiffre.	Libérer le mode de vitesse double après le réglage.
3	PLAY (Mode de vitesse double)		Platine II	ENSEMBLE COMM. PLATINE VR803	TP-R (can. D)	Appuyer sur le contacteur PLAY dans le mode de vitesse double et régler la fréquence pour qu'elle soit dans la limite de \pm 30 Hz du chiffre noté dans l'étape No. 2.	Libérer le mode de vitesse double après le réglage.
4	PLAY			ENSEMBLE COMM. PLATINE VR802		Appuyer sur le contacteur PLAY et régler la fréquence sur 3.010 Hz \pm 10 Hz. Vérifier que le pleurage et scintillement est dans la limite de 0,2%.	

Réglages électriques

■ Vérifier les points suivants et effectuer les opérations suivantes avant procéder aux réglages électriques.

1. Le réglage de la vitesse de bande a été complété.
2. Nettoyer et démagnétiser la tête avec un démagnétiseur de tête.
3. Lors de la mesure, le niveau doit être de 0 dBV = 1 Vepp.
4. Utiliser la face A de la bande spécifiée pour le réglage. STD-331B: Pour le réglage du système de lecture.
STD-630: Bande vierge NORMAL
STD-620: Bande vierge CrO₂
STD-610: Bande vierge METAL
5. Préparer les instruments de mesure suivants: Millivoltmètre CA, oscillateur à basse fréquence, éatténuateur et oscilloscope.
6. Régler les deux canaux L (gauche) et R (droit), sauf spécification contraire.
7. Régler les commutateurs DOLBY NR sur la position OFF, sauf spécification contraire.
8. Laisser chauffer l'appareil pendant plusieurs minutes avant le réglage. En particulier avant d'effectuer le réglage de la réponse en fréquence d'enregistrement et de lecture, laisser chauffer l'appareil pendant 3 à 5 minutes dans le mode d'enregistrement/lecture (REC/PLAY).

9. Toujours suivre l'ordre spécifié de la méthode réglage. Tout changement de l'ordre peut provoquer des résultats imparfaits.

Liste des réglages

Platine I

1. Azimut de la tête
2. Niveau de lecture
3. Réponse en fréquence d'enregistrement/lecture
4. Niveau d'enregistrement

Platine II

1. Azimut de la tête
2. Niveau de lecture
3. Réponse en fréquence d'enregistrement/lecture
4. Niveau d'enregistrement

Vérification des Platines I et II

1. Vérifier que le ALC fonctionne correctement.

• Réglage de la Platine I

- La Platine I est équipée d'un mécanisme de sélection automatique de bande.
- Remarque: Ne pas commuter entre le sens avant (FWD) et le sens arrière (REV) pendant que le tournevis est inséré.

1. Réglage d'azimut de la tête

Opération	Sélecteur de bande	Mode	Signal appliqué / bande d'étalonnage	Emplacement du réglage	Emplacement du point de mesure	Valeur relevée	Observations
1	NORM	PLAY	Reproduire la bande d'étalonnage STD-331B (10 kHz, -20 dB).	Vis de réglage d'azimut de tête (Fig. 6-4)	TP-L (can. G) TP-R (can. D)	Niveau maximum du signal de lecture	Une fois le réglage terminé, bloquer la vis avec un frein de vis.

2. Réglage du niveau de lecture

- Toujours effectuer un réglage minutieux, car la valeur réglée sera le niveau Dolby pour la lecture.

Opération	Sélecteur de bande	Mode	Signal appliqué / bande d'étalonnage	Emplacement du réglage	Emplacement du point de mesure	Valeur relevée	Observations
1	NORM	PLAY	Reproduire la bande d'étalonnage STD-331B (315 kHz, 0 dB)	VR453 (can. G) VR454 (can. D)	TP-L (can. G) TP-R (can. D)	-6.7 dBV	

3. Réglage de la réponse fréquence d'enregistrement/lecture

- Cette opération réglant la polarisation d'enregistrement, faire attention de ne pas augmenter la distorsion par un réglage insuffisant de la polarisation.

Opération	Sélecteur de bande	Mode	Signal appliqué / bande d'étalonnage	Emplacement du réglage	Emplacement du point de mesure	Valeur relevée	Observations
1	NORM	REC	Charger la bande d'étalonnage STD-630 et régler dans le mode d'enregistrement.	—	Partie entre ① et ② (ensemble d'enregistrement (REC)) indiquée sur la Fig. 6-1.	Vérifier que la fréquence d'oscillation est de 105 kHz \pm 1 kHz.	Si la valeur de réglage ne peut pas être réglée dans les limites spécifiées, régler T1401 de l'ensemble REC.
2	NORM	REC	Appliquer un signal de 315 Hz à la borne d'entrée CD et régler la fonction sur "CD".	Niveau du signal d'entrée	TP-L (can. G) TP-R (can. D)	-27 dBV	
3	NORM	REC / PLAY	Enregistrer et reproduire la bande d'étalonnage STD-630 (315 Hz et 10 kHz).	Ensemble enr. (REC) VR1403 (can. G) VR1404 (can. D)	TP-L (can. G) TP-R (can. D)	Répéter la correction de sorte que le niveau de lecture de 10 kHz soit de 0 \pm 0,5 dB en relation avec 315 Hz.	

4. Réglage du niveau d'enregistrement

Opération	Sélecteur de bande	Mode	Signal appliqué / bande d'étalonnage	Emplacement du réglage	Emplacement du point de mesure	Valeur relevée	Observations
1	NORM	REC	Appliquer un signal de 315 Hz à la borne d'entrée CD et régler la fonction sur "CD".	Niveau du signal d'entrée	TP-L (can. G) TP-R (can. D)	-7.7 dBV	
2	NORM	REC / PLAY	Enregistrer et reproduire la bande d'essai STD-630 (315 Hz et 10 kHz).	Ensemble enr. (REC) VR1401 (can. G) VR1402 (can. D)	TP-L (can. G) TP-R (can. D)	Répéter l'enregistrement et la correction de sorte que le niveau de lecture de 315 Hz soit de -6,7 dBV.	

• Réglage de la Platine II

- La Platine II est équipée d'un mécanisme de sélection automatique de bande.
- Remarque: Ne pas commuter entre le sens avant (FWD) et le sens arrière (REV) pendant que le tournevis est inséré.

1. Réglage d'azimut de la tête

Opération	Sélecteur de bande	Mode	Signal appliqué / bande d'étalonnage	Emplacement du réglage	Emplacement du point de mesure	Valeur relevée	Observations
1	NORM	PLAY	Reproduire la bande d'étalonnage STD-331B (10 kHz, -20 dB).	Vis de réglage d'azimut de tête (Fig. 6-4)	TP-L (can. G) TP-R (can. D)	Niveau maximum du signal de lecture	Une fois le réglage terminé, bloquer la vis avec un frein de vis.

2. Réglage du niveau de lecture

- Toujours effectuer un réglage minutieux, car la valeur réglée sera le niveau Dolby pour la lecture.

Opération	Sélecteur de bande	Mode	Signal appliqué / bande d'étalonnage	Emplacement du réglage	Emplacement du point de mesure	Valeur relevée	Observations
1	NORM	PLAY	Reproduire la bande d'étalonnage STD-331B (315 Hz, 0 dB)	VR451 (can. G) VR452 (can. D)	TP-L (can. G) TP-R (can. D)	-6.7 dBV	

3. Réglage de la réponse fréquence d'enregistrement/lecture

- Cette opération réglant la polarisation d'enregistrement, faire attention de ne pas augmenter la distorsion par un réglage insuffisant de la polarisation.

Opération	Sélecteur de bande	Mode	Signal appliqué / bande d'étalonnage	Emplacement du réglage	Emplacement du point de mesure	Valeur relevée	Observations
1	NORM	REC	Charger la bande d'étalonnage STD-630 et régler dans le mode d'enregistrement.	—	Partie entre ④ et ⑤ (ensemble d'enregistrement (AF) indiquée sur la Fig. 6-1.	Vérifier que la fréquence d'oscillation est de 105 kHz \pm 1 kHz.	Si la valeur de réglage ne peut pas être réglée dans les limites spécifiées, régler T581.
2	NORM	REC	Appliquer un signal de 315 Hz à la borne d'entrée CD et régler la fonction sur "CD".	Niveau du signal d'entrée	TP-L (can. G) TP-R (can. D)	-27 dBV	
3	NORM	REC / PLAY	Enregistrer et reproduire la bande d'étalonnage STD-630 (315 Hz et 10 kHz).	VR411 (can. G) VR412 (can. D)	TP-L (can. G) TP-R (can. D)	Répéter la correction de sorte que le niveau de lecture de 10 kHz soit de 0 \pm 0,5 dB en relation avec 315 Hz.	

4. Réglage du niveau d'enregistrement

Opération	Sélecteur de bande	Mode	Signal appliqué / bande d'étalonnage	Emplacement du réglage	Emplacement du point de mesure	Valeur relevée	Observations
1	NORM	REC	Appliquer un signal de 315 Hz à la borne d'entrée CD et régler la fonction sur "CD".	Niveau du signal d'entrée	TP-L (can. G) TP-R (can. D)	-7.7 dBV	
2	NORM	REC / PLAY	Enregistrer et reproduire la bande d'essai STD-630 (315 Hz).	VR1401 (can. G) VR1402 (can. D)	TP-L (can. G) TP-R (can. D)	Répéter l'enregistrement et la correction de sorte que le niveau de lecture de 315 Hz soit de -6,7 dBV.	

• Vérification de la Platines I et II

1. Action du ALC

Opération	Sélecteur de bande	Mode	Signal appliqué / bande d'étalonnage	Emplacement du réglage	Emplacement du point de mesure	Valeur relevée	Observations
1	NORM	REC	Appliquer un signal de 315 Hz à la borne d'entrée CD et régler la fonction sur "CD".	Niveau du signal d'entrée	TP-L (can. G) TP-R (can. D)	-7.7 dBV	
2				+ 10 dB par rapport au niveau d'entrée de l'étape 1.		-2.7 dBV \pm 2.5 dB	

6. AJUSTE

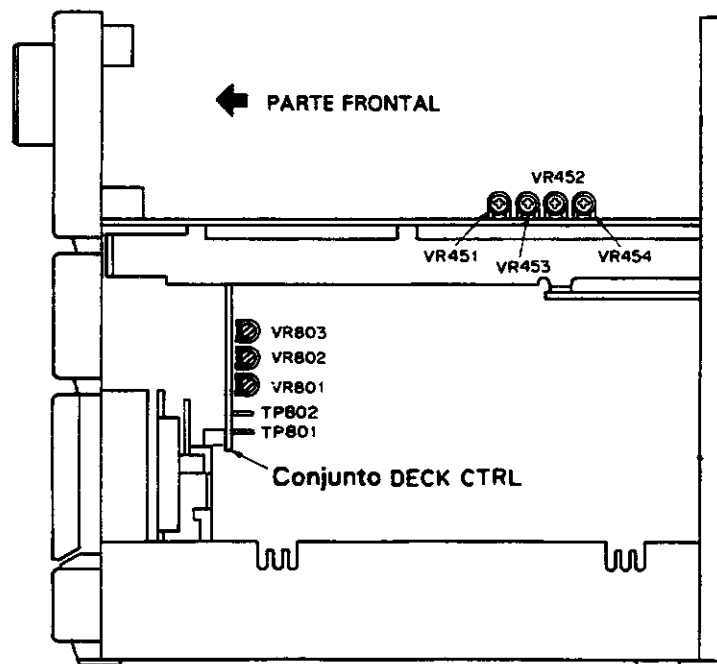
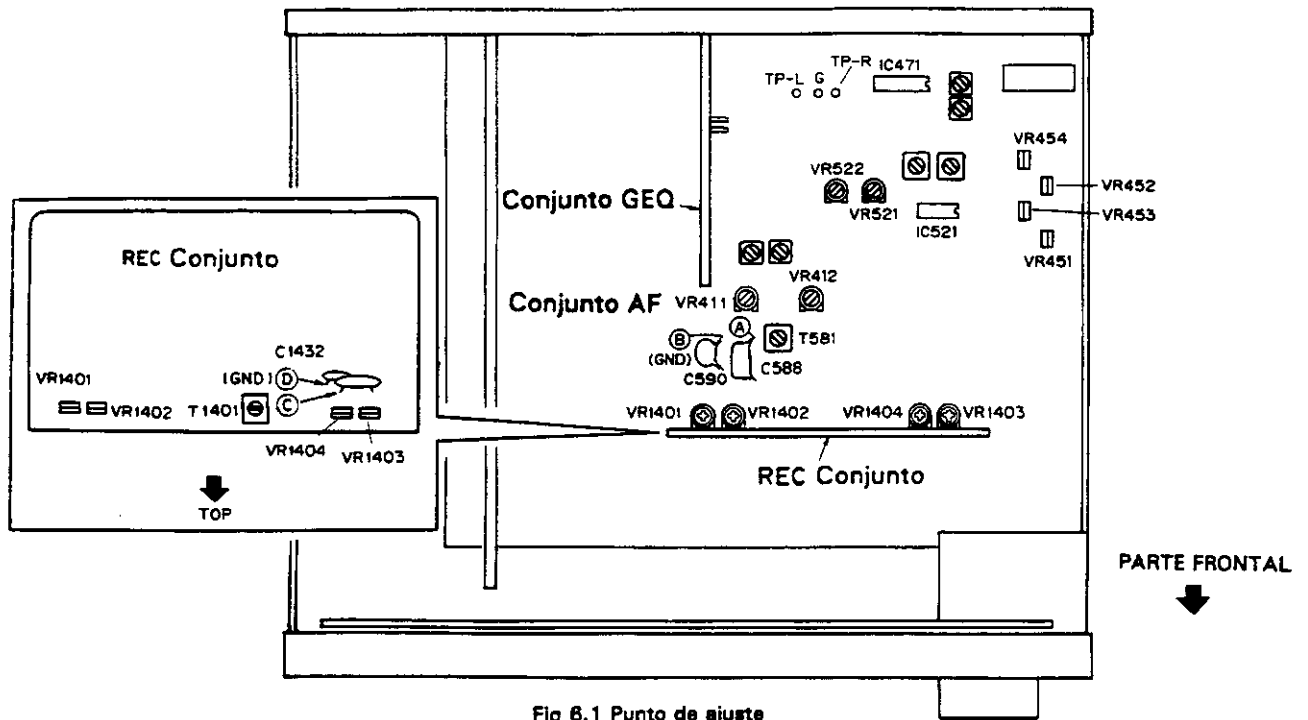

- El ajuste y la medición se realizarán normalmente en el conjunto AF, a menos que se especifique otra cosa.
- Desactive (OFF) el ecualizador gráfico, ponga el control de equilibrio en el centro, y ajuste el volumen de mezcla de micrófono al mínimo (MIN).
- La función deberá estar ajustada siempre a "TAPE", a menos que se especifique otra cosa.

Ajuste del sistema mecánico

- Cinta de prueba: STD-301 (3 kHz, 30 min)
- Ajuste del modo de velocidad doble: Cortocircuite TP801 y TP802 del conjunto de control. Para desactivar el modo, abra el cortocircuito.

1. Ajuste de la velocidad de la cinta							
Nº	Modo	Señal de entrada/cinta de prueba	Punto de ajuste		Punto de medición	Valor de ajuste	Observaciones
1	PLAY	Reproducción de la cinta STDy301 a 3 kHz	Sección I	VR801 del conjunto DECK CTRL	TP-L (canal izquierdo)	Presione PLAY SW y ajuste la frecuencia a 3010 Hz \pm 10 Hz. Cerciórese de que la fluctuación y el efecto de trémolo estén dentro de los límites del 0,2%.	
2	PLAY (Modo de velocidad doble)			—		Presione PLAY SW en el modo de velocidad doble y compruebe si la frecuencia es 6000 Hz \pm 1000 Hz. Anote el valor.	Después del ajuste, desactive el modo de velocidad doble.
3	PLAY (Modo de velocidad doble)		Sección II	VR803 del conjunto DECK CTRL	TP-R (canal derecho)	Presione PLAY SW en el modo de velocidad doble y ajuste la frecuencia de forma que quede a \pm 30 Hz del valor anotado en el paso N°2.	Después del ajuste, desactive el modo de velocidad doble.
4	PLAY			VR802 del conjunto DECK CTRL		Presione PLAY SW y ajuste la frecuencia a 3010 Hz \pm 10 Hz. Cerciórese de que la fluctuación y el efecto de trémolo estén dentro de los límites del 0,2%.	

Ajuste del sistema eléctrico

■ Antes de ajustar el sistema eléctrico, compruebe y realice lo siguiente.

1. El ajuste de la velocidad de la cinta ha finalizado.
2. Limpie y desmagnetice la cabeza empleando un desmagnetizador de cabezas.
3. Cuando se mida, el nivel de nivel debe ser de 0 dBV = 1V rms.
4. Emplee el lado A de la cinta especificada para realizar el ajuste.
STD-331B: Para ajuste del sistema de reproducción.
STD-630: Cinta en blanco NORMAL
STD-620: Cinta en blanco de CrO₂
SRD-610: Cinta en blanco de METAL
5. Prepare los dispositivos de medición siguientes: Milivoltímetro de CA, oscilador de baja frecuencia, atenuador, y osciloscopio
6. Ajuste ambos canales, izquierdo y derecho, a menos que se especifique otra cosa.
7. Ponga los interruptores DOLBY NR en OFF, a menos que se especifique otra cosa.
8. Antes del ajuste, deje que la unidad se caliente durante varios minutos.
Especialmente antes de ajustar las características de frecuencia de grabación y reproducción, deje

que se caliente durante 3 a 5 minutos en el modo REC/PLAY.

9. Cerciórese de seguir el orden apropiado del procedimiento de ajuste. Cualquier cambio en el orden podría causar un resultado imperfecto.

Lista de ajuste

Sección I

1. Azimut de la cabeza
2. Nivel de reproducción
3. Características de frecuencia de grabación/reproducción
4. Nivel de grabación

Sección II

1. Azimut de la cabeza
2. Nivel de reproducción
3. Características de frecuencia de grabación/reproducción
4. Nivel de grabación

Comprobación de las secciones I y II

1. Cerciórese de que ALC esté funcionando adecuadamente.

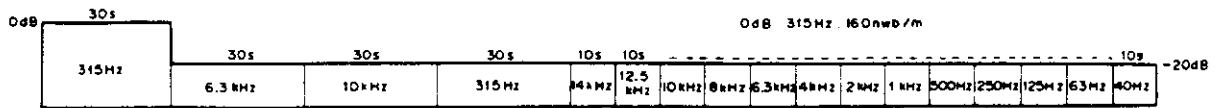
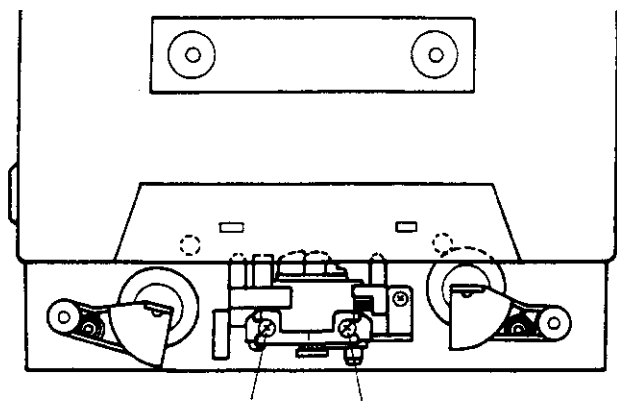

Fig. 6.3 Cinta de prueba STD-331B



Tornillo de ajuste azimut de FWD Tornillo de ajuste azimut de REV

Fig. 6.4 Ajuste del azimut de la cabeza

REPRODUCCIÓN

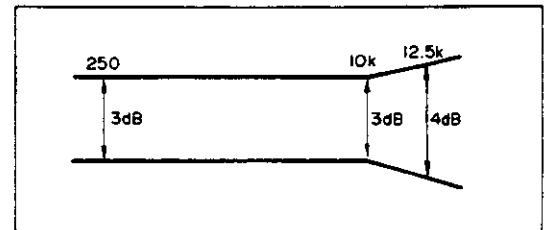

CRABACIÓN

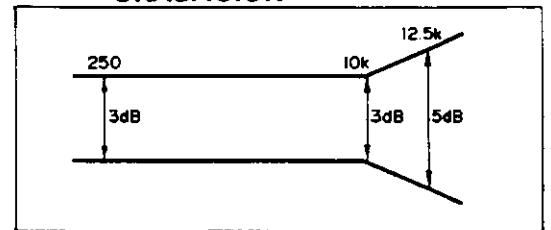

Fig. 6.5 Características de frecuencia

- **Ajuste de la sección I**
- La sección I dispone de un mecanismo selector automático de cinta.
- Nota: No cambie a FWD ni a REV mientras el destornillador esté insertado.

1. Ajuste azimutal de la cabeza

Procedimiento	Selector de cinta	Modo	Señal de entrada / cinta de prueba	Punto de ajuste	Punto de medición	Valor de ajuste	Observaciones
1	NORM	PLAY	Ponga la cinta de prueba STD-331B en reproducción (10 kHz, -20 dB).	Tornillo de ajuste azimutal de la cabeza (Fig. 6-4)	TP-L (canal izquierdo) TP-R (canal derecho)	Nivel máximo de la señal de reproducción	Bloquea el tornillo con tornillos después de terminado el ajuste.

2. Ajuste del nivel de reproducción

- Tenga mucho cuidado durante el ajuste, ya que el valor ajustado será el nivel Dolby fijado para reproducción.

Procedimiento	Selector de cinta	Modo	Señal de entrada / cinta de prueba	Punto de ajuste	Punto de medición	Valor de ajuste	Observaciones
1	NORM	PLAY	Ponga la cinta de prueba STD-331B en reproducción (315 Hz, 0 dB).	VR453 (canal izquierdo) VR454 (canal derecho)	TP-L (canal izquierdo) TP-R (canal derecho)	-6.7 dBV	

3. Ajuste de las características de frecuencia de grabación/reproducción

- Como este procedimiento es para el ajuste de la polarización de grabación, tenga cuidado de no aumentar el valor de distorsión mediante el subajuste de la polarización.

Procedimiento	Selector de cinta	Modo	Señal de entrada / cinta de prueba	Punto de ajuste	Punto de medición	Valor de ajuste	Observaciones
1	NORM	REC	Cargue la cinta de prueba STD-630 y establezca el modo de grabación.	—	Área entre C y D (conjunto de REC) mostrada en la Fig. 6-1.	Confirme que la frecuencia de oscilación sea de 105 kHz \pm 1 kHz.	Si el valor de ajuste no puede establecerse dentro de la especificación, ajuste T1401 del conjunto de REC.
2	NORM	REC	Aplice una señal de 315 Hz al terminal de entrada CD y ajuste la función a "CD".	Nivel de la señal de entrada	TP-L (canal izquierdo) TP-R (canal derecho)	-27.7 dBV	
3	NORM	REC / PLAY	Grabe y reproduzca la cinta de prueba STD-630 (315 Hz y 10 kHz).	Conjunto REC VR1403 (canal izquierdo) VR1404 (canal derecho)	TP-L (canal izquierdo) TP-R (canal derecho)	Repita la corrección de forma que el nivel de reproducción de 10 kHz sea de 0 \pm 0,5 dB en relación con 315 Hz.	

4. Ajuste del nivel de grabación

Procedimiento	Selector de cinta	Modo	Señal de entrada / cinta de prueba	Punto de ajuste	Punto de medición	Valor de ajuste	Observaciones
1	NORM	REC	Aplice una señal de 315 Hz al terminal de entrada CD y ajuste la función a "CD".	Nivel de la señal de entrada	TP-L (canal izquierdo) TP-R (canal derecho)	-7.7 dBV	
2	NORM	REC / PLAY	Grabe y reproduzca la cinta de prueba STD-630 (315 Hz y 10 kHz).	Conjunto REC VR1401 (canal izquierdo) VR1402 (canal derecho)	TP-L (canal izquierdo) TP-R (canal derecho)	Grabe y reproduzca la cinta de prueba de forma que el nivel de reproducción de 315 Hz sea de -6,7 dBV.	

• Ajuste de la sección II

- La sección II dispone de un mecanismo selector automático de cinta.
- Nota: No cambie a FWD ni a REV mientras el destornillador esté insertado.

1. Ajuste azimutal de la cabeza

Procedimiento	Selector de cinta	Modo	Señal de entrada / cinta de prueba	Punto de ajuste	Punto de medición	Valor de ajuste	Observaciones
1	NORM	PLAY	Ponga la cinta de prueba STD-331B en reproducción (10 kHz, -20 dB).	Tornillo de ajuste azimutal de la cabeza (Fig. 6-4)	TP-L (canal izquierdo) TP-R (canal derecho)	Nivel máximo de la señal de reproducción	Bloquee el tornillo con bloqueador de tornillos después de haber terminado el ajuste.

2. Ajuste del nivel de reproducción

- Tenga mucho cuidado durante el ajuste, ya que el valor ajustado será el nivel Dolby fijado para reproducción.

Procedimiento	Selector de cinta	Modo	Señal de entrada / cinta de prueba	Punto de ajuste	Punto de medición	Valor de ajuste	Observaciones
1	NORM	PLAY	Ponga la cinta de prueba STD-331B en reproducción (315 Hz, 0 dB).	VR451 (canal izquierdo) VR452 (canal derecho)	TP-L (canal izquierdo) TP-R (canal derecho)	-6.7 dBV	

3. Ajuste de las características de frecuencia de grabación/reproducción

- Como este procedimiento es para el ajuste de la polarización de grabación, tenga cuidado de no aumentar el valor de distorsión mediante el subajuste de la polarización.

Procedimiento	Selector de cinta	Modo	Señal de entrada / cinta de prueba	Punto de ajuste	Punto de medición	Valor de ajuste	Observaciones
1	NORM	REC	Cargue la cinta de prueba STD-630 y establezca el modo de grabación.	—	Área entre (A) y (B) (conjunto de AF) mostrada en la Fig. 6-1.	Confirme que la frecuencia de oscilación sea de 105 kHz \pm 1 kHz.	Si el valor de ajuste no puede establecerse dentro de la especificación, ajuste T581.
2	NORM	REC	Aplique una señal de 315 Hz al terminal de entrada CD y ajuste la función a "CD".	Nivel de la señal de entrada	TP-L (canal izquierdo) TP-R (canal derecho)	-27.7 dBV	
3	NORM	REC / PLAY	Grabe y reproduzca la cinta de prueba STD-630 (315 Hz y 10 kHz).	VR411 (canal izquierdo) VR412 (canal derecho)	TP-L (canal izquierdo) TP-R (canal derecho)	Repita la corrección de forma que el nivel de reproducción de 10 kHz sea de 0 \pm 0,5 dB en relación con 315 Hz.	

4. Ajuste del nivel de grabación

Procedimiento	Selector de cinta	Modo	Señal de entrada / cinta de prueba	Punto de ajuste	Punto de medición	Valor de ajuste	Observaciones
1	NORM	REC	Aplique una señal de 315 Hz al terminal de entrada CD y ajuste la función a "CD".	Nivel de la señal de entrada	TP-L (canal izquierdo) TP-R (canal derecho)	-7.7 dBV	
2	NORM	REC / PLAY	Grabe y reproduzca la cinta de prueba STD-630 (315 Hz).	VR521 (canal izquierdo) VR522 (canal derecho)	TP-L (canal izquierdo) TP-R (canal derecho)	Grabe y reproduzca la cinta de prueba de forma que el nivel de reproducción de 315 Hz sea de -6,7 dBV.	

• Procedimiento de comprobación para las secciones I y II

1. Acción del ALC

Procedimiento	Selector de cinta	Modo	Señal de entrada / cinta de prueba	Punto de ajuste	Punto de medición	Valor de ajuste	Observaciones
1	NORM	REC	Aplique una señal de 315 Hz al terminal de entrada CD y ajuste la función a "CD".	Nivel de la señal de entrada	TP-L (canal izquierdo) TP-R (canal derecho)	-7.7 dBV	
2				+10 dB contra el nivel de entrada del paso 1.		-2.7 dBV \pm 2.5 dB	

7. IC INFORMATION

● Terminal function of PD3133

No.	Terminal name	I/O	Function		Active
1 5	S7 S11	0	Segment 7 Segment 11	Outputs segment control signals of the FL indicator.	H
6 12	G1 G7	0	Grid 1 Grid 7	Outputs grid control signals of the FL indicator (Rch).	H
13 17	G1 G5	0	Grid 1 Grid 7	Outputs grid control signals of the FL indicator (Lch).	H
18		I	Not used (pull-down with the resistor).		—
19		—	-27V power supply input for FL indicator control. If these -27V are not supplied when AC voltage of the filament is applied, the FL indicator will go off.		—
20 22	6G 8G	0	Grid 6 Grid 8	Outputs grid control signals of the FL indicator.	H
23	DIRECT	I	Direct detection When the DIRECT switch of the AMP is pressed and this terminal becomes "H" by Pin59 of the IC801(PDE029), turns the characteristics of the graphic EQ to flat.		H
24	SR	I	SR remote control signal input.		L
25	GE DATA	0	DATA	Outputs control signal of the IC603 (LC7522).	H/L
26	GE CLOCK	0	CLOCK		
27	POWER	I	Power supply detection. When the power is turned on and "H" is input to this terminal from Pin20 of the IC801(PDE029), it becomes operation mode. If "H" is not input (when "L"), it becomes backup mode.		H
28	A	0	A(Pin11)	Outputs control signal of the IC726 (TC4041BP).	H/L
29	B	0	B(Pin10)		
30	C	0	C(Pin9)		
31	SPA IN	I	Inputs the comparison result of the level comparator IC725 (NJM4558DXP). (decides whether Pin1 of the IC725 is "H" or "L"). (See Note1 on P.76).		H/L
32	VCC	—	+5V Power supply.		—

No.	Terminal name	I/O	Function		Active
33	A/D0(LSB)	0	LSB MSB	Outputs voltage for comparison of the comparator of the D/A converter (See Note1 on P.76).	H/L
34	A/D1				
35	A/D2				
36	A/D3				
37	A/D4(MSB)				
38	BPF RESET	0	RESET of band-pass filter output for Spectrum Analyzer. After measuring the level of the Lch, reset the output of each band-pass filter to level zero, then proceed to measure the level of the Rch.		H
39	CTRL Rch	0	Selects input of the band-pass filter for Spectral Analyzer (See Note1 on P.76).	Lch	L
40	CTRL Lch	0		Rch	L
41	K01	0	Outputs key scan signal.		L
42	K00				
43 46	K13 K10	1	Inputs key scan signal.		L
47	RESET	1	Inputs RESET signal.		H
48	OSC2	0	4.19MHz ceramic oscillator connection terminal.		—
49	OSC1	1			—
50	GND	—	Grounding.		—
51	CL1	1	Pull-up to Vcc as it is not used.		—
52	CL2	0	Not used.		—
53	<u>TEST</u>	1	Pull-up to Vcc.		—
54 58	K02 K06	0	Outputs key scan signal.		L
59 64	S1 S6	0	Outputs segment control signal of the FL indicator.		H

Note 1: Spectral Analyser Indication Unit

Spectral Analyser indication unit is as shown in Fig. 7-1.

The microcomputer IC771 (PD3133) and a comparator IC725 (NJM4558DXP) measure the Lch and Rch or respective band levels and control the level indication.

Thus, the channel level is measured one by one for every one band. When all bands of Lch and Rch are measured, the results will be displayed all at once. The measurement is made by repeating B.P.F. output RESET, Lch 15 kHz to 60 Hz, B.P.F. output RESET, Rch 15 kHz to 60 Hz, level indication, B.P.F. output RESET, Lch.

Respective band levels of the Spectral Analyser are measured as follows: outputs reference voltage (V_{Ref}) for five times; decides whether the output from the comparator is "H" or "L"; specifies the fifth output of the reference voltage as the measuring level and decides in which point of 11 steps the level is positioned; displays the level.

Thus, the difference of measuring times for low level measurement and high level measurement can be eliminated to allow level measurement of the respective band by unit time.

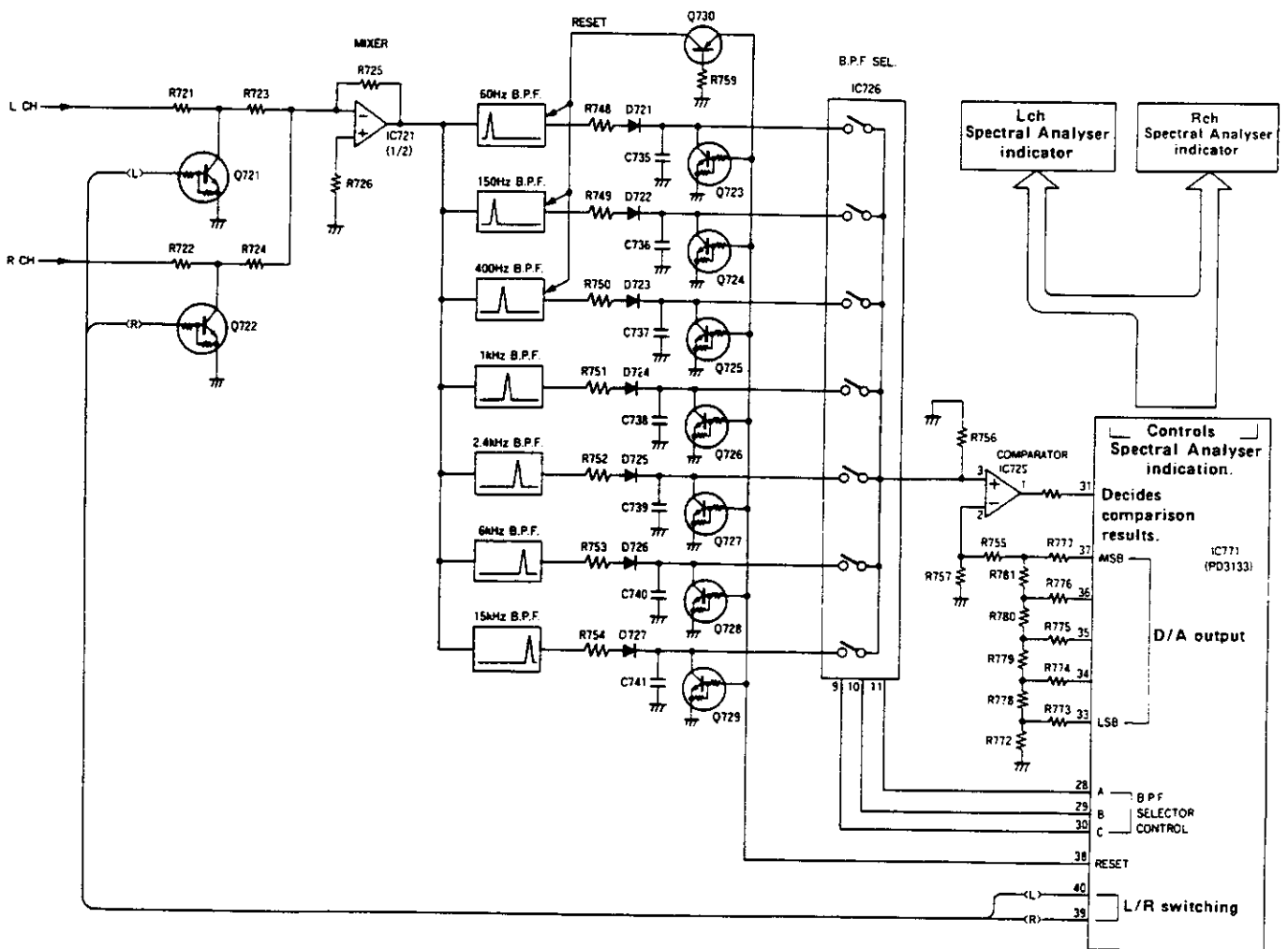

Fig.7-1 Block diagram of Spectral Analyser indication unit

Level measurement works, mentioned as below. 5 bit DATA "10000" (1/2 of maximum value, See Fig. 7-2.) puts out first from the D/A output of the Pins 33 to 37 of the IC771 (PD3133). The second DATA to be output is decided by "H" or "L" of the comparator output at this point. If the output is "H", the reference voltage (V_{Ref}) is lower. "11000", the intermediate value of "10000" (the first output) and the maximum value "11111", will be the second output. The third DATA to be output is decided by "H" or "L" of the comparator output at this point. If the output is "L", the reference voltage (V_{Ref}) is higher.

"10100", the intermediate value of "11000" (the second output) and "10000" (the first output), will be output third.

The fourth DATA to be output is decided by "H" and "L" of the comparator output at this point.

If the output is "L", the reference voltage (V_{Ref}) is still higher. "10010", the intermediate value of "10100" (the third output) and "10000" (the first output), will be output fourth.

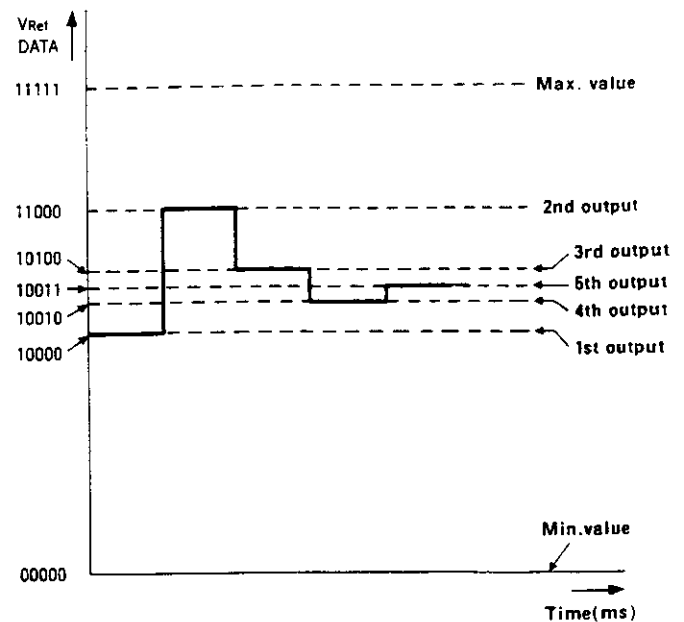

Fig.7-2 Level measurement action

The fifth DATA to be output is decided by "H" and "L" of the comparator output at this point. If the output is "H", the reference voltage (V_{Ref}) is still lower. "10011", the intermediate value of "10010" (the fourth output) and "10100" (the third output), will be output fifth. The fifth DATA value "10011" is specified as the the result of measurement. Finally, how many points of Spectral Analyser should be lit up is decided from this DATA "10011". All bands of Lch and Rch are displayed all at once after measurement.

Terminal Function of PDE029-C(DECK control microcomputer)

Note: I: CMOS input, N: Nch open drain output,

O: CMOS output, UN: Nch open drain output with pull-up MOS transistor

No.	Terminal name	I/O	Function	Active																						
1	S1(DATA1)	N	Used for sending/receiving of DATA with microcomputer of TUNER.	H/L																						
2	S0(DATA2)	O		H/L																						
3	SC	O		H/L																						
4	SREQ	O	Not used.	—																						
5	FADER (LED)	O	Light up LED during FADER REC mode.	H																						
6	1 BIAS	O	Not used.	—																						
7	2 BIAS	O	Oscillates BIAS only during REC mechanism 2.	H																						
8		I	Not used.	—																						
9	COPY	UN	<p>According to the various statuses in the table below, the control of the IC471 (for DOLBY NR) and for the switching inputs of the REC AMP are depicted as follows.</p> <p>DOLBY NR IC: IC471, HA12136 REC AMP Input Selector: IC521, TC4066BP</p> <table border="1" style="margin-left: auto; margin-right: auto;"> <thead> <tr> <th>FUNCTION</th> <th>REC MODE</th> <th>COPY (Pin 9)</th> <th>DOLBY P/R (Pin 10)</th> </tr> </thead> <tbody> <tr> <td rowspan="2">TAPE</td> <td>REC not operating</td> <td>L</td> <td>L</td> </tr> <tr> <td>REC is operating</td> <td>H</td> <td>L</td> </tr> <tr> <td rowspan="2">Except TAPE</td> <td>REC not operating</td> <td>L</td> <td>L</td> </tr> <tr> <td>REC is operating</td> <td>L</td> <td>H</td> </tr> <tr> <td colspan="2">COPY is operating (both normal speed and double speed)</td> <td>L</td> <td>L</td> </tr> </tbody> </table>	FUNCTION	REC MODE	COPY (Pin 9)	DOLBY P/R (Pin 10)	TAPE	REC not operating	L	L	REC is operating	H	L	Except TAPE	REC not operating	L	L	REC is operating	L	H	COPY is operating (both normal speed and double speed)		L	L	H/L
FUNCTION	REC MODE	COPY (Pin 9)		DOLBY P/R (Pin 10)																						
TAPE	REC not operating	L	L																							
	REC is operating	H	L																							
Except TAPE	REC not operating	L	L																							
	REC is operating	L	H																							
COPY is operating (both normal speed and double speed)		L	L																							
10	Dolby P/R	UN		H/L																						
11	PB1/2	UN	Control switching of playback mechanism (L: mechanism 1).	H/L																						
12	2. REC MUTE	UN	Sets to L only while mechanism 2 is in REC mode.	H																						
13	MS. PULSE	N	MS pulse detection (H: music is searched).	H/L																						
14	1. REC MUTE	UN	Not used.	—																						
15	FADER	UN	Turns Q601 ON to discharge the time constant deciding capacitor C642 when controlling rise time of the power supply of the BIAS oscillation circuit. If the FADER switch is turned on, the unit enters REC PAUSE mode. When the PLAY (FWD and REV) button is pressed, at this time, the terminal will be switched from "H" to "L". In FADER REC during ASES operation, the terminal will be "H" for 100ms when the unit starts up.	H																						
16	PB. MUTE	UN	Turns OFF only during DECK playback mode.	H																						
17	1. PULSE	N	Detects hall device pulse of mechanism 1.	H/L																						
18	2. PULSE	N	Detects hall device pulse of mechanism 2.	H/L																						
19	HI/NORM	N	Controls TAPE SPEED (H: double speed).	H/L																						
20	POW. RY	O	Becomes "H" when POWER is turned ON.	H																						
21	1. MOTOR	N	Controls the motor of mechanism 1. (L: MOTOR rotates).	L																						
22	P. ASES	N	Not used.	—																						

No.	Terminal name	I/O	Function	Active
23	1. ●	N	Not used.	—
24	2. MOTOR	N	Controls the motor of mechanism 2. (L : MOTOR rotates).	L
25	DIGI ON/OFF	O	Not used.	—
26	SP.RY	O	Controls SP RELAY(RY351) Operates MUTE for 5seconds after POWER is turned ON. Turns SP RELAY OFF immediately after POWER is turned OFF.	L
27	V-UP	O	Controls TA7291 and UP/DOWN of the MOTOR VOLUME.	V-UP (Pin 27)
28	V-DOWN	O		V-DOWN (Pin 28)
29	L-MUTE	O	Operates MUTE for 0.5seconds when FUNCTION is switched and SURROUND is ON/OFF and DIRECT is ON/OFF. When POWER is ON, the SP RELAY is turned ON, and it takes 0.3seconds until the output signal of VOLUME(VR391) functions for muting.	H
30	TEST	—	Not used (GND).	—
31	V _{ss}	—	GND.	—
32	OSC1	—	Connects 4.19MHz ceramic resonator.	—
33	OSC2	—		—
34	RES	—	RESET terminal.	L
35	A	O	Transfer DATA of 3bit to the 74LS42P and uses as KEYSKAN OUT K00-K06.	L/H
36	B	O		L/H
37	C	O		L/H
38	1. ▶ (LED)	N	Controls the FWD PLAY LED of mechanism 1.	L
39	1. ◀ (LED)	N	Controls the REV PLAY LED of mechanism 1.	L
40	2. ▶ (LED)	N	Controls the FWD PLAY LED of mechanism 2.	L
41	2. ◀ (LED)	N	Controls the REV PLAY LED of mechanism 2.	L
42	2. ● (LED)	N	Control the REC LED of mechanism 2.	L
43	ASES(LED)	N	Controls the ASES.	L
44	R.REC(LED)	N	Not used.	—
45	R.ASES (LED)	N	Not used.	—
46	SOL2B	O	Controls the solenoid for FF/REW of mechanism 2.	H
47	SOL2A	O	Controls the solenoid for PLAY of mechanism 2.	H
48	SOL1B	O	Controls the solenoid for FF/REW of mechanism 1.	H
49	SOL1A	O	Controls the solenoid for PLAY of mechanism 1.	H

No.	Terminal name	I/O	Function	Active
50 55	K10 K15	I	KEY matrix input.	H/L
56	K16	N		
57	K17			
58	SURROUND	UN	Controls SURROUND ON/OFF.	H
59	DIRECT	UN	Controls DIRECT ON/OFF.	H
60	F-MUTE	UN	Operates MUTE for 0.5seconds when FUNCTION is switched. When POWER is ON after SP RELAY(RY351) is activated (ON), MUTE is operated for 0.3seconds.	H
61	INH	UN	Switches FUNCTION.	H/L
62	B	UN		H/L
63	A	UN		H/L
64	VDD	-	+5V	-

8. FOR HE AND SD TYPES

8.1 CONTRAST OF MISCELLANEOUS PARTS

NOTES:

- Parts without part number cannot be supplied.
- The \triangle mark found on some component parts indicates the importance of the safety factor of the part. Therefore, when replacing, be sure to use parts of identical designation.
- Parts marked by "●" are not always kept in stock. Their delivery time may be longer than usual or they may be unavailable.

The DC-Z92/HE and SD types are the same as the DC-Z92/HB type with the exception of the following sections.

Mark	Symbol & Description	Part No.			Remarks
		DC-Z92/ HB type	DC-Z92/ HE type	DC-Z92/ SD type	
\triangle	POWER SUPPLY assembly CONNECTOR assembly	AWZ2241 Non supply	AWZ2239 Non supply	AWZ2242	
\triangle	FU2001 Fuse (T2A/250V)	AEK-511	AEK-107	AEK-400	
\triangle	FU2002 Fuse (T1.6A/250V)	AEK-405	
\triangle	FU2003 Fuse (T1.6A/250V)	AEK-510	AEK-405	AEK-405	
\triangle	FU2004,FU2005 Fuse (T1.25A/250V)	AEK-509	AEK-018	AEK018	
\triangle	S2001 Line voltage selector switch (AC110V,120V~127V,220V,240V)	AKX1007	
\triangle	S2002 Line voltage selector switch (AC110V,120V~127V,220V,240V)	AKX-507	
\triangle	AC Power cord	ADG-063	ADG1021	ADG1015	
\triangle	T2001 Power transformer (AC220V,240V)	ATS1184	ATS1184	
\triangle	T2001 Power transformer (AC110V,120V~127V,220V,240V)	ATS1185	
	Caution card	ARM1003	
	Operating Instructions (English)	ARB1156	
	Operating Instructions (English, German, French, Italian)	ARE1117	
	Operating Instructions (Dutch, Swedish, Spanish, Portuguese)	ARC1135	
	Operating Instructions (Spanish)	ARC1138	

8.2 FOR HE TYPE

POWER SUPPLY assembly (AWZ2239)

The POWER SUPPLY assembly (AWZ2239:HE type) is the same as the POWER SUPPLY assembly (AWZ2241:HB type) with the exception of the following sections.

Mark	Symbol & Description	Part No.		Remarks
		AWZ2241:HB type	AWZ2239:HE type	
⚠	AC socket (OUTLET)	AKP1035	AKP1034	

CONNECT assembly

The difference in parts between the CONNECT assemblies HB type and HE type is only the jumper wire.

SCHEMATIC AND P.C.BOARDS DIAGRAM

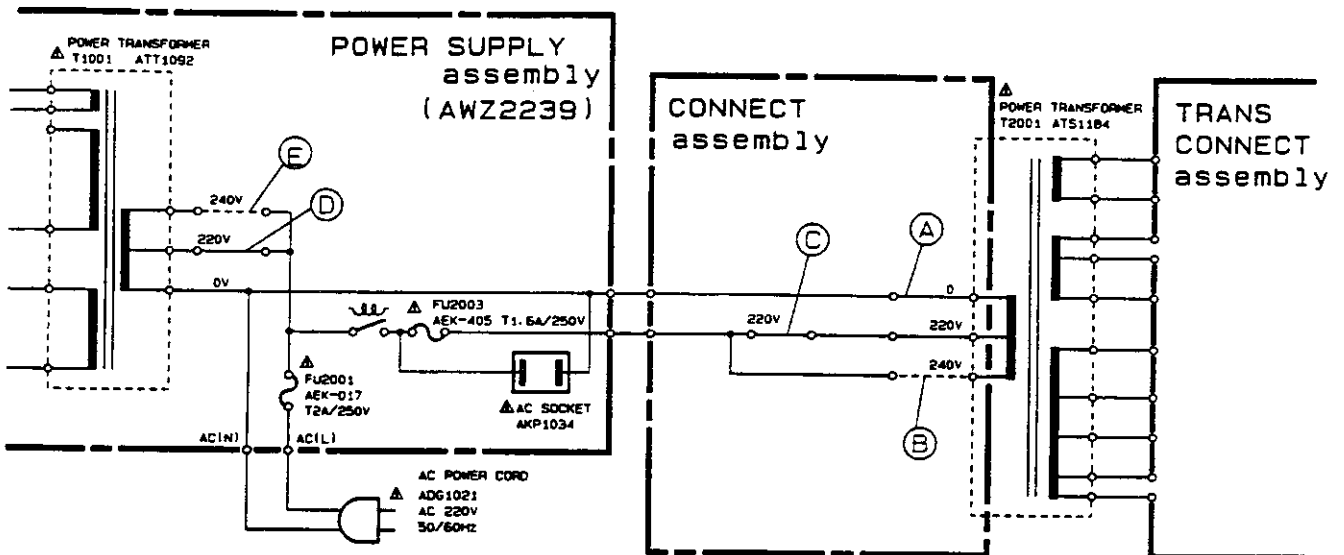

POWER SUPPLY assembly (AWZ2239)

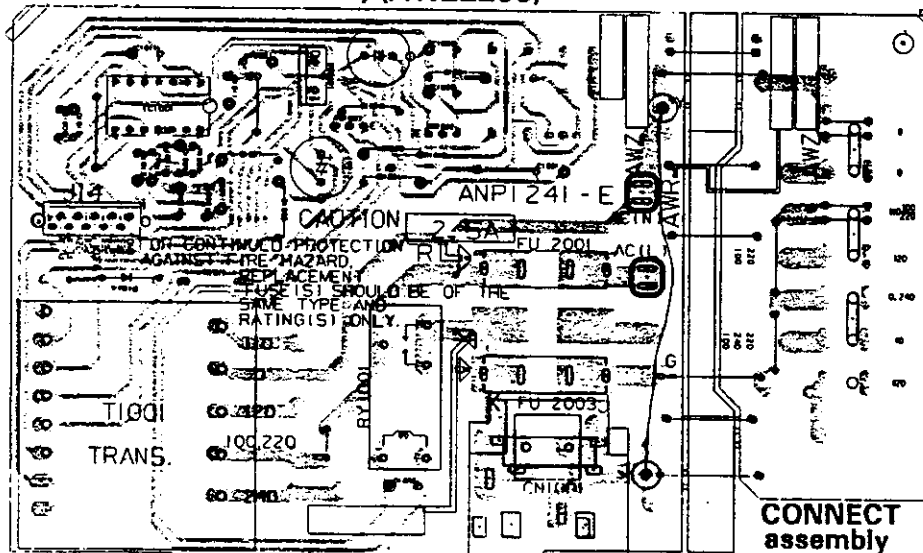

8.3 FOR SD TYPE

POWER SUPPLY assembly (AWZ2242)

The POWER SUPPLY assembly (AWZ2242:SD type) is the same as the POWER SUPPLY assembly (AWZ2241:HB type) with the exception of the following sections.

Mark	Symbol & Description	Part No.		Remarks
		AWZ2241:HB type	AWZ2242:SD type	
⚠	T1001 Power transformer (AC 220V, 240V)	ATT1092	
⚠	T1001 Power transformer (AC110V, 120V~127V, 220V, 240V)	ATT1093	
⚠	AC socket (OUTLET)	AKP1035	AKP1033	

P.C.BOARD DIAGRAM

POWER SUPPLY assembly (AWZ2242)

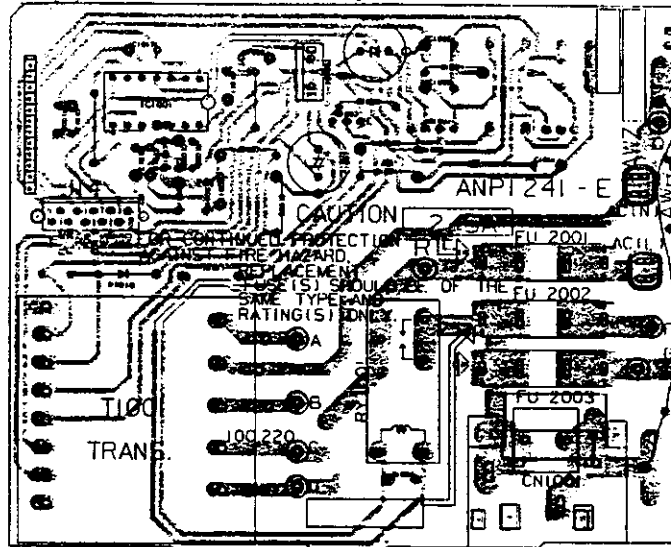

SCHEMATIC DIAGRAM

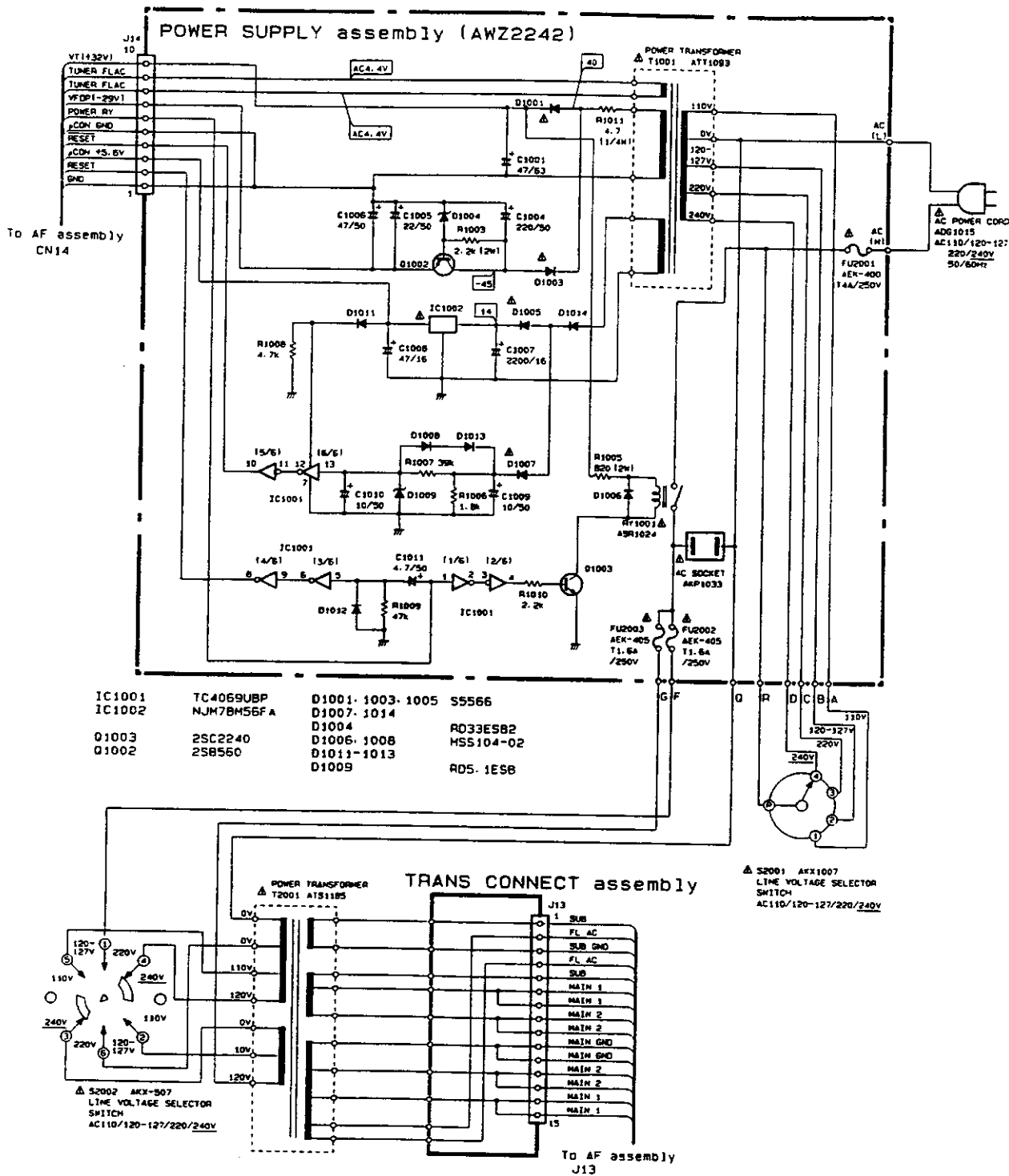

9. CONNECTIONS

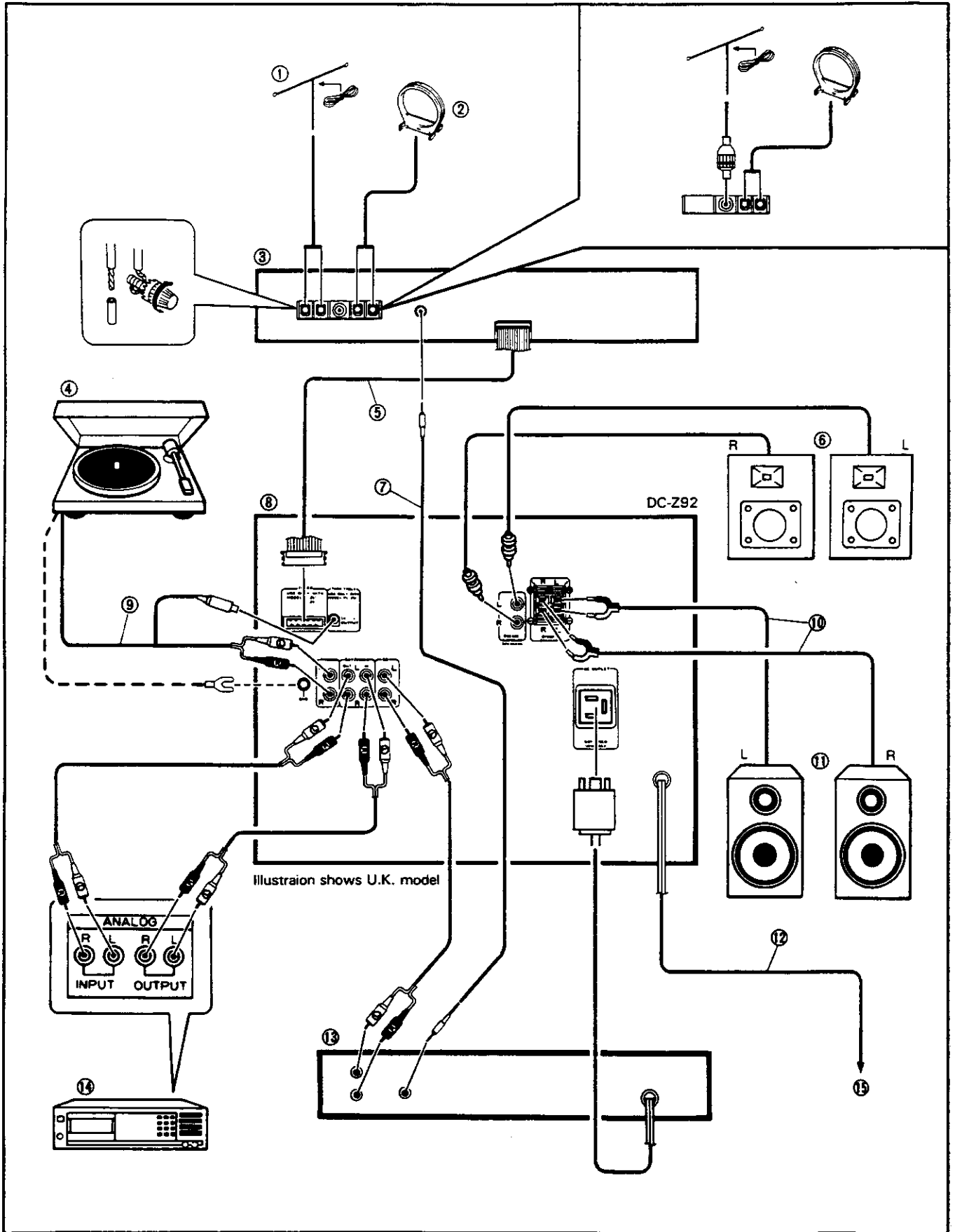

Refer to page 85 for the connections diagram.

- ① Accessory FM antenna
- ② Accessory AM loop antenna
- ③ FM/AM tuner (F-Z92 or F-Z92L)
- ④ Turntable (Separately sold PL-Z82 or PL-Z92)
- ⑤ Tuner input/output cord
- ⑥ Surround speaker system
- ⑦ CD player control cord
- ⑧ Cassette tape deck amplifier
- ⑨ Turntable output cord
- ⑩ Speakers cord
- ⑪ Speaker system
- ⑫ Power cord
- ⑬ CD player (Separately sold PD-Z72T or PD-Z82M)
- ⑭ Digital audio tape deck (DAT) or video cassette recorder (VCR)
- ⑮ AC wall socket

Plug the power cord into the AC wall socket outlet only after all the connections have been completed.

If the FM antenna terminal of the FM/AM tuner is a PAL connector only, then refer to connection diagram B.

Proceed as follows with the set-up and connections.

1. Place the cassette tape deck amplifier on top of the CD player.
2. Connect the CD player OUTPUT jacks to the cassette tape deck amplifier CD INPUT jacks with audio cords.
3. Place the tuner on top of the cassette tape deck amplifier.
4. Connect the tuner input/output cord ⑤ to cassette tape deck amplifier.

TUNER CONNECTION (Page 3, diagram C)

Insert the connector until it locks, thus ensuring that it is connected. When disconnecting the connector, pull it in the opposite direction while pressing the left and right claws.

If using this unit together with the optional PD-Z72T or PD-Z82M, connect the control cord ⑦.

5. Connect the FM antenna ① and the AM loop antenna ② to the tuner's antenna terminals.
6. Place the turntable on top of the tuner.
7. Connect the turntable's cords ⑨ to the cassette tape deck amplifier's jacks.
 - If using this unit together with the optional PL-Z82 or PL-Z92, connect the turntable's audio cords and power supply cord respectively to the cassette tape deck amplifier's PHONO jacks and DC 12V OUTPUT jack.
 - If using a different turntable, connect the audio cord and earth cord.
8. Use the "DAT/VIDEO" jacks for connection to the audio input/output jacks of a DAT or VCR.
 - If connecting an LD player, connect the LD player's audio output jacks to the "DAT/VIDEO" input jacks.

NOTE:

- Insert the plugs securely into the jacks. Improper connection can lead to sound distortion or malfunctioning.
 - The white plug is for the left channel connection and the red plug for the right channel connection.
9. Connect the speaker cords ⑩ to the SPEAKERS terminals.
 - Connect the "+" terminals on the cassette tape deck amplifier to the "+" terminals on the speakers, the "-" terminals on the cassette tape deck amplifier to the "-" terminals on the speakers.

Connecting the speaker cords.

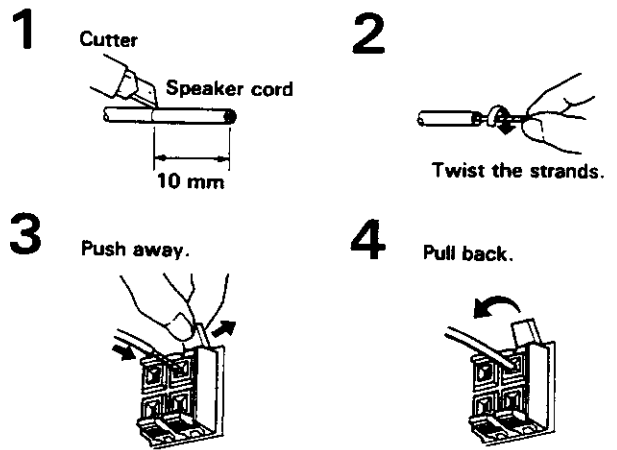

NOTE:

Do not allow the conductors of the cords to project beyond the terminals and to come into contact with other conductors. A breakdown or failure may occur when conductors touch one another.

Speaker impedance

Connect speaker systems with a nominal impedance of between 6 and 16 Ω.

Surround speaker connection

Connect the plugs properly.

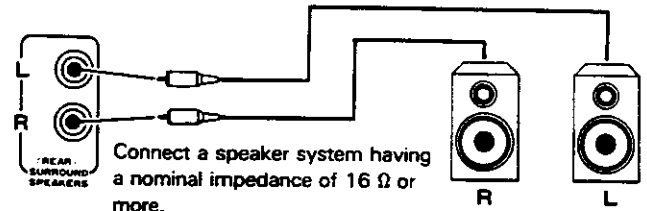

10. Finally, connect the power cord ⑫ to the AC wall socket ⑮.

What is surround sound?

With ordinary stereo, sound normally comes only from speakers in front of the listener. In a concert hall or theater though, sound reflected from the walls and ceiling reaches the listener from all directions. This is what accounts for the feeling of ambience or spaciousness of a live performance.

Surround sound works to reproduce these effects to produce fuller, more "live" sound.

STEREO WIDE

When the surround speakers are not connected, the stereo wide function will be activated. This function enhances the stereo effect. Note that it does not operate in the case of a monaural source, however.

Speaker System Placement Examples

The sound effects obtained in a surround system depend on speaker placement. Experiment with various arrangements to find the one most suited to your tastes.

Placing the speakers so that they are slightly higher than ear level contributes to sound quality.

[Case A]

Good sound dispersion; recommended for movies, etc.

[Case B]

Sound appears to come from directly in front of listener. Good for listening to music recordings.

[Case C]

Offers most varied effects; good for watching sports programs or listening to live recordings.

10. PANEL FACILITIES

DC-Z92

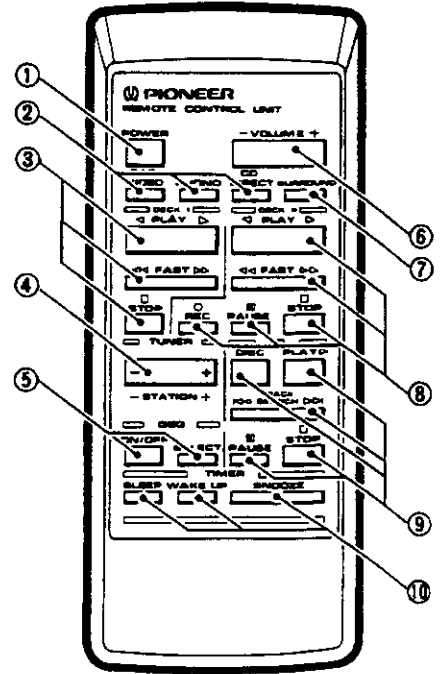
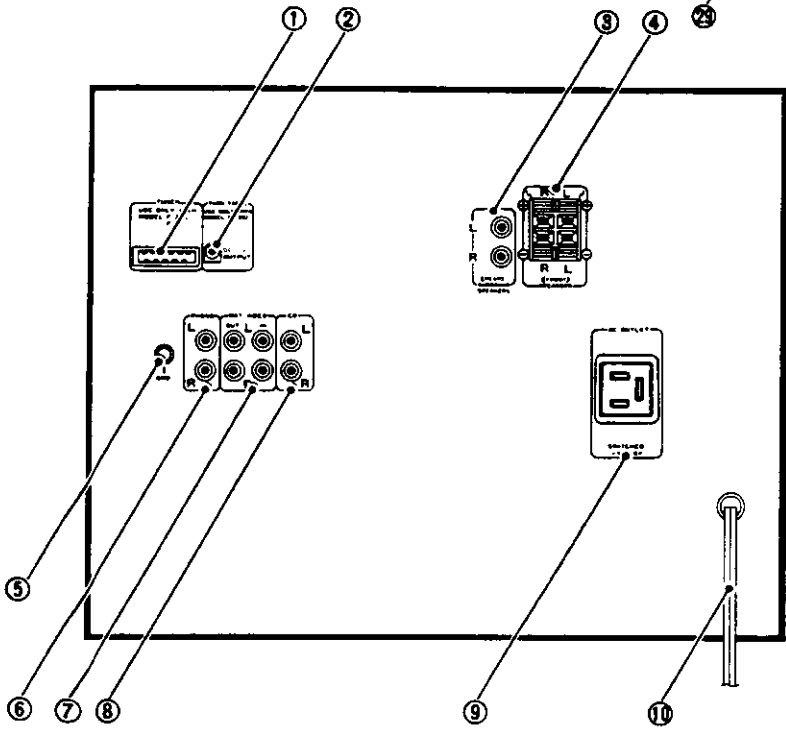
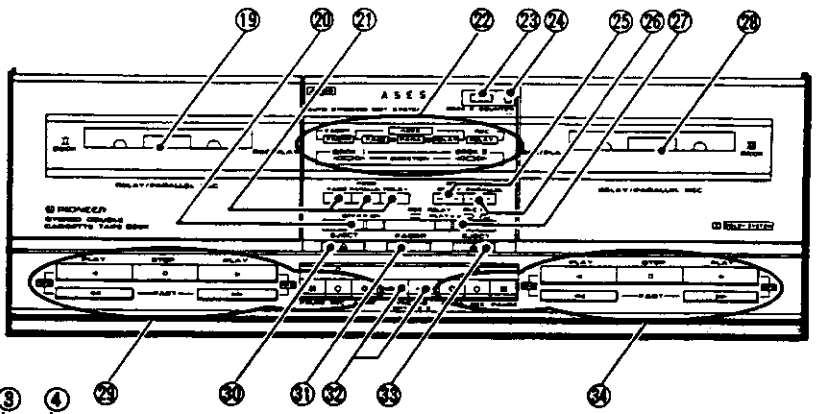
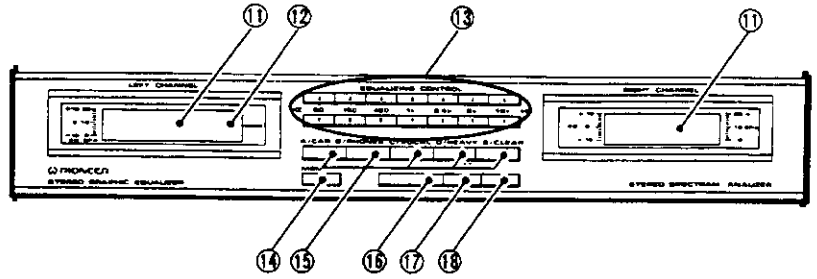
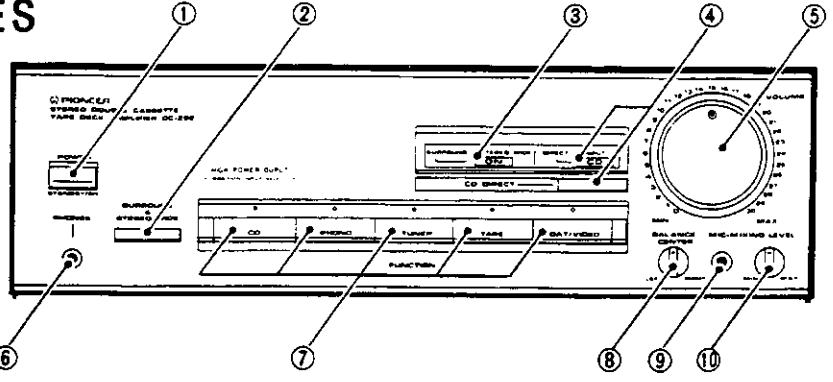
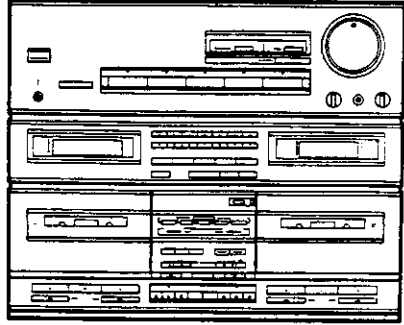

REAR PANEL FACILITIES

Cassette tape deck amplifier: DC-Z92

① TUNER jack

Connect the F-Z92 (or F-Z92L) FM/AM tuner.

② TURNTABLE OUTPUT jack

This jack supplies power to the PL-Z82 or PL-Z92.

③ SURROUND SPEAKERS jacks

Connect the Surround speaker systems.

NOTE:

Connect a speaker system having a nominal impedance of 16Ω or more.

④ SPEAKERS terminals

L: Connect the left speaker system as seen from the listening position.

R: Connect the right speaker system as seen from the listening position.

NOTE:

Connect a speaker system having a nominal impedance ranging from 6Ω to 16Ω.

⑤ Ground terminal (GND)

Connect this to the ground terminal on the turntable (except for PL-Z92 and PL-Z82).

⑥ PHONO input jacks

Connect the audio output cord on the turntable to these jacks.

⑦ DAT/VIDEO jacks

IN: Connect to audio output jacks of DAT, LD player or VCR, etc.

OUT: Connect to audio input jacks of DAT or VCR, etc.

⑧ CD input jacks

Connect to audio output jacks of CD player.

⑨ AC OUTLET (SWITCHED 100 W MAX)

Power supplied through these outlets is turned on and off by the cassette tape deck amplifier's POWER switch. Total electrical power consumption of connected equipment should not exceed 100 W.

NOTE:

Do not connect appliances with high power consumption such as heaters, irons, or television sets to the AC OUTLET in order to avoid overheating or fire risk.

This can cause the cassette tape deck amplifier to malfunction.

⑩ Power cord

Connect this to the AC wall socket.

FRONT PANEL FACILITIES

Cassette tape deck amplifier: DC-Z92

- This unit has an automatic tape selector.
- Recording and playback are possible on both deck I and II.
- Sound can be recorded as adjusted by the graphic equalizer.

Amplifier section

① POWER STANDBY/ON switch

When this switch is set to the on position, power is supplied to the cassette tape deck amplifier's main circuit. The POWER unit's switch is geared to selecting the transformer's secondary so that even in STANDBY position, the unit's circuitry will work as long as the power cord is connected to a power outlet. Disconnect the power cord from the power outlet when you do not plan to use the unit for a long period of time.

The unit is in STANDBY when the tuner section display indicates only the time.

② SURROUND & STEREO WIDE switch

When surround speaker systems are connected to the SURROUND SPEAKERS jacks at the rear: By turning this switch ON, you can enjoy surround reproduction.

When surround speaker systems are not connected: By turning this switch ON, you can enjoy STEREO WIDE reproduction with greater left-right spread.

NOTE:

- In the case of a monaural source, a SURROUND & STEREO WIDE effect cannot be obtained.
- SURROUND & STEREO WIDE function does not operate if CD DIRECT is on.

③ SURROUND & STEREO WIDE indicator

Lights when the SURROUND & STEREO WIDE switch is on.

④ CD DIRECT switch/indicator

Press this switch to listen to a CD without passing the signal through sound quality adjustment circuits.

⑤ VOLUME control

⑥ Headphone jack (PHONES)

For stereo headphone plug.

⑦ FUNCTION switches/indicators

[CD]

Press to listen to a CD player connected to the CD jacks.

[PHONO]

Press to play records on a turntable connected to the PHONO jacks.

[TUNER]

Press to listen to a radio broadcast.

[TAPE]

Press to listen to a cassette tape.

[DAT/VIDEO]

Press to listen to a stereo component connected to the DAT/VIDEO jacks.

⑧ BALANCE control

Usually set this control to the central position. If turned counterclockwise, the volume of the right channel will decrease.

If turned clockwise, the volume of the left channel will decrease.

⑨ Microphone (MIC) jack

This is a standard jack for connecting a microphone.

Mic mixing is not possible when CD DIRECT is on.

⑩ MIXING LEVEL control

Use to adjust volume of microphone and playback sound.

Graphic Equalizer section

11 Graphic equalizer/Spectrum analyzer display

Ordinarily this shows the spectrum analyzer display. It shows a graphic equalizer display during operation of the EQUALIZING CONTROL switches.

12 MODE display

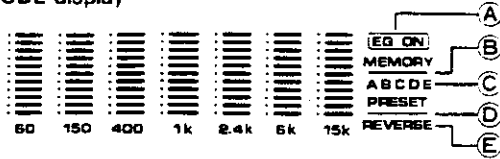

A EQ ON indicator

Lights when the EQUALIZER switch is set to ON. When this indicator is lit, the graphic equalizer can be used to adjust sound quality.

B MEMORY indicator

When the line is lit under "MEMORY", it indicates that the equalization curves memorized in the memory recall switches can be recalled.

C A - E indicators

Indicates which equalization curve is currently recalled.

A: Curve stored in A/CAR.

B: Curve stored in B/PHONES.

C: Curve stored in C/VOCAL.

D: Curve stored in D/HEAVY.

E: Curve stored in E/CLEAR.

D PRESET indicator

When the line is lit under "PRESET", it indicates that the equalization curves preset in the memory recall switches can be recalled.

E REVERSE indicator

Lights when the FLAT/REVERSE switch is used to invert the equalization curve.

13 EQUALIZING CONTROL switches

These strengthen or weaken the indicated frequency band. Press the upper switch to emphasize; press the lower switch to attenuate.

14 MEMORY switch

Use to store equalization curves in the memory recall switches.

15 Memory recall switches

Use to recall equalization curves.

16 EQUALIZER switch

Turns the equalizer on and off. The EQ ON indicator lights when this switch is on.

The equalizer can not be used to adjust the sound when CD DIRECT is on.

17 FLAT/REVERSE switch

Press once to reset the equalizer to flat response (no equalization). Press again to reverse the previous curve (boosted frequencies will be reduced, and vice versa).

18 PRESET/MEMORY switch

Determines whether the equalizer curves recalled by the Memory recall switches will be your own programmed memorized curves or the factory preset curves.

Cassette Tape Deck Section

19 Deck I cassette door

20 DOLBY* NR switch

Set this switch to the ON position to activate the DOLBY NR system.

- Tapes recorded using Dolby noise reduction system should always be played back with the noise reduction system on. Sound quality will be adversely affected if they are played back with the system off, or if tapes recorded using a different noise reduction system are played back with the Dolby NR system on.

- It is recommended that tapes recorded using Dolby B NR be so marked on the label. This will help to prevent incorrect setting of the noise reduction switch during playback.

Dolby noise reduction manufactured under license from Dolby Laboratories Licensing Corporation. "DOLBY" and the double-D symbol  are trademarks of Dolby Laboratories Licensing Corporation.

21 ASES switch

Use to automatically record a CD on cassette tape.

FADE: The sound will fade out at the end of the tape.

PARALLEL: Deck I and Deck II record at the same time.

RELAY: Recording continues on Deck II after tape ends on Deck I. If using this unit together with the PD-Z72T CD player, Deck II will record disc II after Deck I finishes recording disc I.

Using ASES after putting both decks I and II into the stop mode.

22 Operation indicators

FADER: lights when the FADER switch is on.

ASES

FADE: fade edit in progress.

PARA: parallel edit in progress.

RELAY: relay edit in progress.

RELAY REC: indicates relay recording in progress using Deck I and Deck II.

Direction (◀, ▶): Indicates direction of tape travel during recording or playback. Flashes slowly in pause mode. Flashes rapidly during Music Search (MS).

23 DECK II COUNTER

24 Counter reset switch

Press this switch to reset the Deck II tape counter display to 000.

25 RELAY RECORDING switch

Use for relay recording from Deck I to Deck II.

Deck II starts recording when Deck I finishes.

Use after putting both decks I and II into the stop mode.

26 PARALLEL RECORDING switch

Deck I and Deck II record at the same time.

Use after putting both decks I and II into the stop mode.

27 REVERSE MODE switch

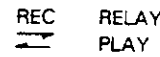
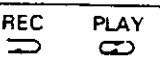
Switch position	During playback	During recording
	Plays both tape sides. When one deck finishes playback, the other side begins playback of both tape sides. (6 times maximum). If there is a tape in only one deck, then that deck continuously plays both sides of the tape. (6 times maximum).	Records on one side.
	Plays both sides continuously. (6 times maximum.)	Records on both sides.

28 Deck II cassette door

29 Deck I Operation switches

- ▶ **PLAY (FWD)** For playing back a tape in the forward mode.
- ◀ **PLAY (REV)** For playing back a tape in the reverse mode.
- **STOP** For stopping the tape.
- ▶▶ **FAST** Fast forward in forward mode, rewind in reverse mode. Music search (MS) starts if this is pressed during playback.
- ◀◀ **FAST** Rewind in forward mode, fast forward in reverse mode. Music search (MS) starts if this is pressed during playback.
- ▢ **PAUSE** Temporarily stops tape travel. Cancels pause mode when pressed again or press the PLAY switch.
- **REC** Sets recording standby mode. The REC indicator lights and the DIRECTION indicators (◀ and ▶) flash. Recording will then begin when you press the PLAY switch (◀ or ▶).
- **MUTE** A blank no-signal area is recorded on the tape while this is kept depressed while recording. Useful for creating gaps between songs.

30 Deck I EJECT switch

31 FADER switch

This switch is used to gradually fade out a recorded loaded tape in deck II. (The sound will be completely cut off after approximately 10 seconds and the tape will stop.)

32 SYNCHRO COPY switches

Use for tape copying.

NORM: Copying from the Deck I tape to the Deck II tape at normal recording/playback speed.

HIGH: Copying at about twice normal tape speed. (Copies can be made in about half the NORM time.)

33 Deck II EJECT switch

34 Deck II Operation switches

- ▶ **PLAY (FWD)** For playing back a tape in the forward mode.
- ◀ **PLAY (REV)** For playing back a tape in the reverse mode.
- **STOP** For stopping the tape.
- ▶▶ **FAST** Fast forward in forward mode, rewind in reverse mode. Music search (MS) starts if this is pressed during playback.
- ◀◀ **FAST** Rewind in forward mode, fast forward in reverse mode. Music search (MS) starts if this is pressed during playback.
- ▢ **PAUSE** Temporarily stops tape travel. Cancels pause mode when pressed again or press the PLAY switch.
- **REC** Sets recording standby mode. The REC indicator lights and the DIRECTION indicators (◀ and ▶) flash. Recording will then begin when you press the PLAY switch (◀ or ▶).
- **MUTE** A blank no-signal area is recorded on the tape while this is kept depressed while recording. Useful for creating gaps between songs.

Remote control unit

1 POWER key

2 Function keys

- DAT/VIDEO** Sets function to DAT/VIDEO.
- PHONO** Sets function to PHONO.
- CD DIRECT** Sets function to CD DIRECT.

3 DECK I operation keys

- ▶ Forward play
- ◀ Reverse play
- Stop
- ▶▶ Fast forward in forward mode, rewind in reverse mode. Music search (MS) starts if this is pressed during playback.
- ◀◀ Rewind in forward mode, fast forward in reverse mode. Music search (MS) starts if this is pressed during playback.

4 TUNER STATION key

- Before operation, memorize broadcast stations in the STATION CALL switches.
- + Stations change in order in the upward direction
- Stations change in order in the downward direction.

5 Graphic equalizer (GEQ) operation keys.

- ON/OFF:** Turns the equalizer on and off.
- SELECT:** Recalls the preset equalization curves (PRESET) and memorized equalization curves (MEMORY) in sequence.

6 VOLUME UP (+)/DOWN (-) keys

7 SURROUND key

Turns SURROUND & STEREO WIDE on and off.

8 DECK II operation keys

- ▶ Forward play
- ◀ Reverse play
- ▶▶ Fast forward in forward mode, rewind in reverse mode. Music search (MS) starts if this is pressed during playback.
- ◀◀ Rewind in forward mode, fast forward in reverse mode. Music search (MS) starts if this is pressed during playback.
- Stop
- ▢ Pause
- REC (recording standby). Next, press the play key to begin recording.

9 CD operation keys

Perform the connections so that the CD player is operated by the remote control unit.

- ▶ Play
- DISC DISC selection
- Stop
- ⏸ Pause
- ◀◀, ▶▶ ... Track search

NOTE:

Note that the DISC selector key on the accessory remote control unit may not function, depending on the CD player used.

10 Timer operation keys

SLEEP: Sets the sleep timer. Each time you press this key, the setting changes as shown here. The current setting is shown on the tuner display.

Power turns off when your set time has elapsed.

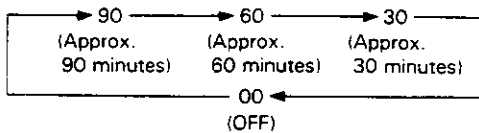

If you press the SLEEP key during SLEEP operation, the display will show the time remaining till power turns off.

WAKE-UP: Timer playback setting/cancellation can be performed when the timer playback time has been set. This is shown in the tuner display section.

SNOOZE: Turns off power if pressed after timer playback begins. Timer playback begins again approx. 5 minutes later.

The amplifier section function automatically switches to the music source being operated when you press the CD playback (▶), cassette tape deck playback (◀, ▶), or tuner station controls.

To operate with the remote control unit, use the keys with the same function indicating symbols (for example ▶) as those shown on the components.

NOTE:

It is not possible to operate the CD player with the remote control unless the remote control cord is connected (refer to page 2)

Range of remote control

When the remote control unit is pointed at the remote sensor window on the tuner and any of its keys is pressed, the tuner and other components can be operated by remote control.

Distance: Within a range of approx. 7 meters from the remote sensor window on the tuner.

Angle: Within approx. 30 degrees from the center of the remote sensor window on the tuner.

Remote control will not be possible if there is an obstacle between the remote control unit itself and the remote sensor window on the tuner.

11. SPECIFICATIONS

Cassette tape deck amplifier: DC-Z92

AMPLIFIER SECTION

Continuous Average Power Output is 50 Watts* per channel, min., at 8 ohms from 40 Hertz to 20,000 Hertz, with no more than 0.3% total harmonic distortion.

*Measured pursuant to the Federal Trade Commission's Trade Regulation rules on Power Output Claims for Amplifiers.

Music power	90 W + 90 W (1 kHz, T.H.D. 1%, 8 ohms)
Music power (DIN).....	90 W + 90 W (1 kHz, T.H.D. 1%, 8 ohms)
Peak music power	390 W (8 ohms)
Continuous Power Output (DIN)	60 W + 60 W
	(1 kHz, T.H.D. 1%, 8 ohms)
Graphic equalizer frequency band.....	60 Hz, 150 Hz,
	400 Hz, 1 kHz, 2.4 kHz, 6 kHz, 15 kHz, ± 7 dB
Signal-to-Noise Ratio (IHF, short-circuited, A network)	
PHONO	72 dB
Signal-to-Noise Ratio (DIN, continuous Power/50 mW)	
PHONO	68 dB/60 dB
Total Harmonic Distortion	
(40 Hz to 20,000 Hz, 30 W, 8 ohms)**	No more than 0.2%

Tape Deck Section

Systems	4 track, 2-channel stereo
Heads	Recording/playback head x 2
	Erasing head x 2
Motor.....	DC servo 2 speed motor x 2
Wow and Flutter.....	No more than 0.09% (WRMS)
Fast Winding Time	Approximately 95 seconds
	(C-60 tape)

Frequency Response (-20 dB recording):

Normal tape	35 Hz to 14,000 Hz ± 6 dB
CrO ₂ tape	35 Hz to 15,000 Hz ± 6 dB
Metal tape	35 Hz to 16,000 Hz ± 6 dB
Signal-to-Noise Ratio	
Dolby NR OFF.....	56 dB
Noise Reduction Effect	
Dolby B type NR ON	More than 10 dB (at 5 kHz)

Furnished Parts

Operating Instructions	1
Remote control unit	1
Dry cell batteries	2

Miscellaneous

Power requirements

U.K. and Australian models	a.c. 240 Volts ~, 50/60 Hz
Other destination models	
..... AC 110/120 - 127/220/240 V (switchable)	50/60 Hz
Power Consumption	426 W
Dimensions	360 (W) x 287 (H) x 334 (D) mm
	14-3/16 (W) x 11-5/16 (H) x 13-1/8 (D) in
Weight (without package).....	9.2 kg (20 lb 5 oz)

Accessories

EP Adaptor.....	1
-----------------	---

• Specifications and design subject to possible modification without notice due to improvement.

**Measured By Audio Spectrum Analyzer.