

Service Manual

PIONEER
The future of sound and vision.

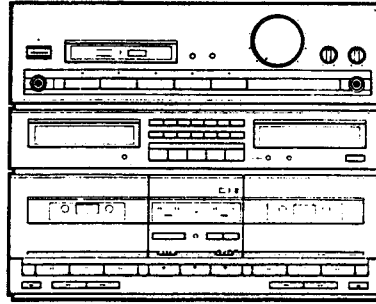

ORDER NO.
ARP1916

STEREO DOUBLE CASSETTE DECK AMPLIFIER **DC-Z83**

DC-Z83 HAS FOLLOWING VERSIONS:

Type	Power requirement	Export destination
HB	AC220V, 240V (switchable)*	United Kingdom
HE	AC220V, 240V (switchable)*	European continent
HEWZ	AC220V, 240V (switchable)*	West Germany
YPW	AC240V only	Australia
SD	AC110V, 120V-127V, 220V, 240V (switchable)	Kingdom of Saudi Arabia and General market

*: Change the Jumper wires of assembly boards.

- This manual is applicable to the DC-Z83/HB and HE types.
- As to the HE type, refer to page 68.
- As to the other types, refer to applicable service manuals.
- Ce manuel pour le service comprend les explications de réglage en français.
- Este manual de servicio trata del método ajuste escrito en español.
- As to the system composition, refer to the S-222 service manual (ARP1936).

CONTENTS

1. EXPLODED VIEWS, PACKING AND PARTS LIST	2	5. FOR HE TYPE	68
2. SCHEMATIC DIAGRAMS AND P.C. BOARD CONNECTION DIAGRAMS	12	6. PANEL FACILITIES	69
3. P.C.B's PARTS LIST	47	7. SPECIFICATIONS	73
4. ADJUSTMENTS	53		
4. RÉGLAGE	58		
4. AJUSTE	63		

PIONEER ELECTRONIC CORPORATION 4-1, Meguro 1-Chome, Meguro-ku, Tokyo 153, Japan
PIONEER ELECTRONICS SERVICE INC. P.O. Box 1760, Long Beach, California 90801 U.S.A.
PIONEER ELECTRONICS OF CANADA, INC. 505 Cochrane Drive, Markham, Ontario L3R 8E3 Canada
PIONEER ELECTRONIC [EUROPE] N.V. Keetberglaan 1, 2740 Beveren, Belgium
PIONEER ELECTRONICS AUSTRALIA PTY. LTD. 178-184 Boundary Road, Braeside, Victoria 3195, Australia TEL: [03] 580-9911
 © PIONEER ELECTRONIC CORPORATION 1990

YV JAN. 1990 Printed in japan.

2703

1. EXPLODED VIEWS, PACKING AND PARTS LIST

1.1 PARTS LIST OF EXTERIOR AND PACKING

NOTES:

- Parts without part number cannot be supplied.
- The Δ mark found on some component parts indicates the importance of the safety factor of the part. Therefore, when replacing, be sure to use parts of identical designation.
- Parts marked by "◎" are not always kept in stock. Their delivery time may be longer than usual or they may be unavailable.

Mark	No.	Description	Parts No.	Mark	No.	Description	Parts No.
	1	Knob (VOLUME)	AAB1135		46	"AAA" dry cell	
	2	Rotary knob	AAB1136		47	Front pad (L.R)	AHA1314
	3	Button (REC)	AAD1668		48	Rear pad (L.R)	AHA1315
	4	Button (POWER)	AAD1674		49	Packing case	AHD1796
	5	Button (COPY)	AAD1676		50	Battery cover	AZN1846
	6	Button	AAD1682		51	Sheet	
	7	Button (FUNCTION)	AAD1711		52	Terminal screw	
	8	Button (GEQ)	AAD1712		53	Front panel	AMB1636
	9	Button (EQUALIZER)	AAD1713		54	P.C.B mold	
	10	Button (EJECT)	AAD1716		55	Eject arm (L)	AMR2031
	11	Button (PLAY)	AAD1718		56	Eject arm (R)	AMR2032
	12	Slide knob	AAE1128		57	Chassis	
	13	Indicator lens (POWER)	AAK1800		58	Rear panel	
	14	Indicator lens	AAK1801		59	Bonnet case	ANE1218
	15	Decorative plate (AMP U)	AAK1804		60	Plate	
	16	Decorative plate (DOOR R)	AAK1873		61	Plate B	
	17	Decorative plate (AMP D)	AAK1877		62	Plate	
	18	Decorative plate (GEQ L)	AAK1878		63	Plate	
	19	Decorative plate (GEQ R)	AAK1879		64	Plate A	
	20	Decorative plate (DECK)	AAK1880		65	Plate	
	21	Decorative plate (DOOR L)	AAK1882		66	Heat sink	
	22	...			67	Shield plate	
	23	Cassette door (L)	AAN1177		68	Operating instructions	ARB1222
	24	Cassette door (R)	AAN1181		69	...	
	25	Counter	AAW1009		70	...	
	26		71	SPEANA assembly	AWG1025
	27		72	FUNCTION assembly	AWK1174
	28		73	AF assembly	AWZ2632
	29	Lavel	AAX1301		74	MAIN VR assembly	
	30	Screw	ABA1084		75	HEAD PHONE assembly	
	31	Screw (STEEL)	ABA1095		76	TRANS CONNECT assembly	
	32	Washer (PAPER)			77	BALANCE assembly	
	33	Spring 1	ABH1062		78	GEQ assembly	AWG1028
	34	Spring 2	ABH1063		79	MIC assembly	
	35	Keep plate	ABK1011		80	DECK-1 SW assembly	
	36	Earth lead			81	DECK-2 SW assembly	
	37	Earth lead			82	DECK CENTER assembly	
Δ	38	AC power cord	ADG1052		83	DECK CTRL assembly	AWZ2641
	39	Counter belt	AEB1110		84	AMP,GEQ CTRL assembly	AWZ2642
	40	Nylon binder			85	POWER SUPPLY assembly	AWZ2241
	41	Leg assembly	AEC-847		86	CONNECT assembly	
Δ	42	Strain relief	AEC-882		87	Mechanism unit 1	AWY1052
	43	Spacer (PCB)			88	Mechanism unit 2	AWY1054
	44	Nylon rivet			89	Damper assembly	AXA1008
	45	Clamper			90	Remote control unit (CU-DC020)	AXD1132

A

Mark	No.	Description	Parts No.
	91	Screw	BBZ30P060FMC
	92	Screw	BBZ30P080FCU
	93	Screw	BBZ30P080FZK
	94	Screw	BBZ30P180FMC
	95	Screw	BPZ26P080FMC
	96	Nut	NK90FUC
	97	Screw	VPZ30P080FZK
⚠	98	Fuse (T2A/250V, FU2001)	AEK-511
⚠	99	Fuse (T1.6A/250V, FU2003)	AEK-510
⚠	100	Fuse (T1.25A/250V, FU2004)	AEK-509
⚠	101	Fuse (T1.25A/250V, FU2005)	AEK-509
⚠	102	Power transformer (T2001)	ATS1252
	103	Screw	VPZ30P080FMC

B



1.2 PACKING

C

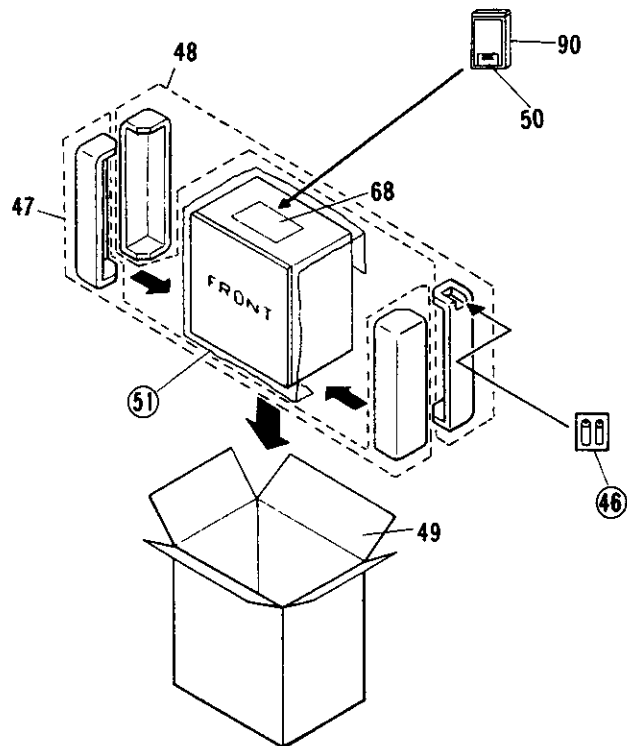

D

1.3 EXTERIOR

DC-Z83

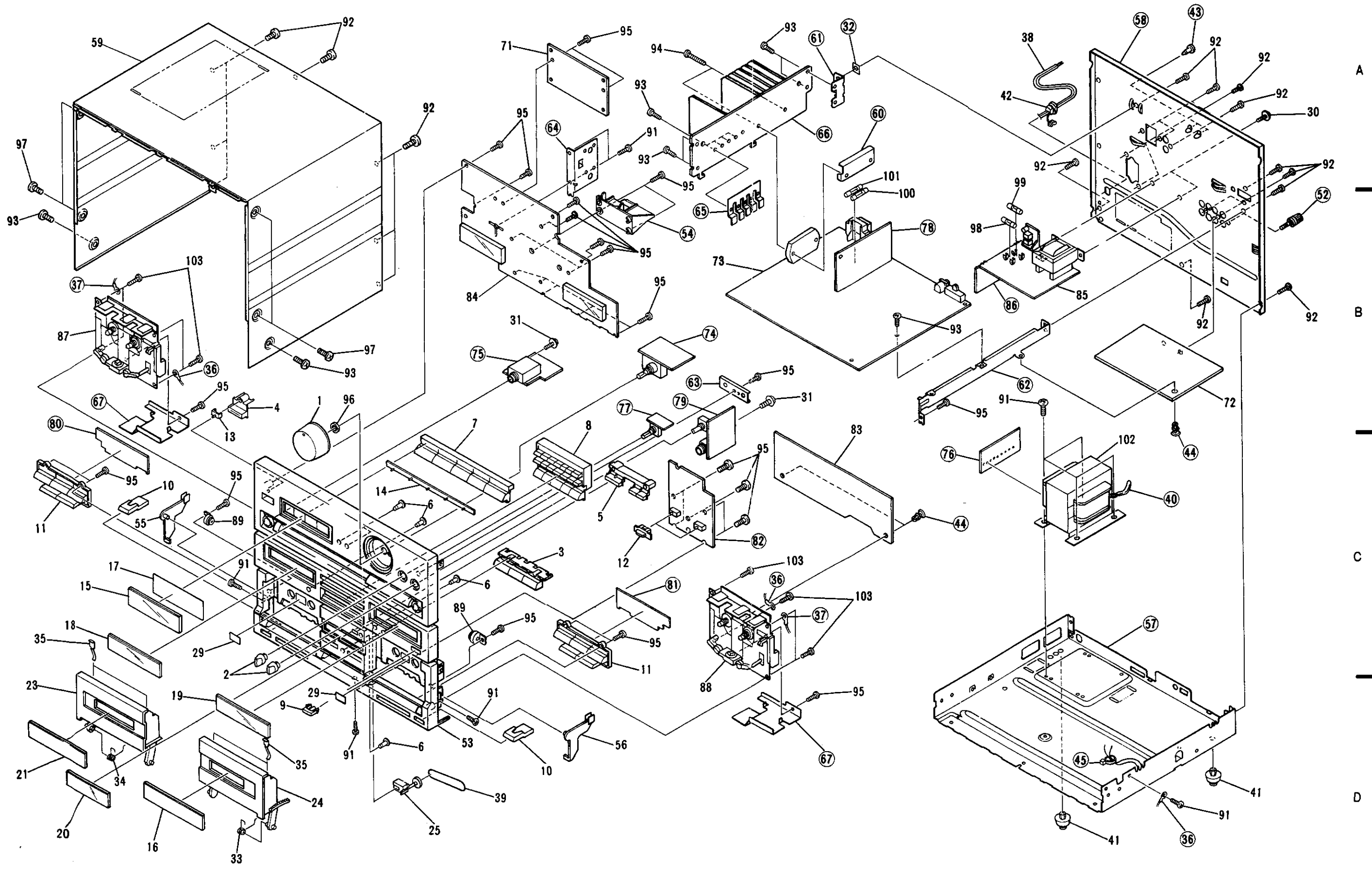

A

B

C

D

4

5

6

7

8

9

4

5

6

7

8

9

1.4 MECHA UNIT 1 (AWY1052)

Mark	No.	Parts No.	Description	Mark	No.	Parts No.	Description
	1	AZE1018	Hall IC	51	AZN1976	Gear arm R assembly	
	2	AZX1019	Motor	52	AZN1977	Gear arm L assembly	
	3	AZS1054	Leaf SW (MODE)	53	AZN1326	Head lever calking assembly	
	4	AZS1034	Leaf SW (CrO2)	54	AZN1327	FW assembly	
	5	AZN1286	Drive arm assembly	55		Head P.C.board	
	6	AZN1287	FW assembly A	56		Plate (FLY WHEEL)	
	7	AZN1288	Cam gear	57	AZN1328	Azimuth plate	
	8	AZN1289	Reel	58		SW arm	
	9	AZN1971	FR arm	59	
	10	AZN1972	Pinch arm L assembly	60	
	11	AZN1973	Pinch arm R assembly	61	AZN1330	Head arm	
	12	AZN1293	Gear	62	AZN1331	Azimuth spring	
	13	AZN1294	H Gear	63	AZN1332	Cassette stopper	
	14	AZN1793	CUE arm	64	AZN1978	Trigger arm	
	15	AZB1079	Screw	65	AZN1334	Head frame	
	16	66	AZN1335	Cassette guide L	
	17	AZN1984	Collar C	67	AZN1336	Cassette guide R	
	18	AZN1297	Motor pully	68	AZN1337	Cassette guide	
	19	AZN1298	Belt	69	AZN1338	Cam gear	
	20	AZN1299	Spring	70	AZN1994	Head holder	
	21	AZN1300	FR lever spring	71	AZN1340	Head gear	
	22	AZN1301	FWF spring	72	AZN1980	Eject arm 2	
	23	AZN1302	FWR spring	73	AZN1342	Select lever	
	24	AZN1303	Spring	74	AZN1343	Brake	
	25	AZB1297	Screw	75	
	26	AZN1305	Cable holder	76	AZN1981	Ratch lever L	
	27	AZN1306	Spring	77	AZN1346	Metal	
	28	AZN1307	Spring	78	AZN1347	Metal	
	29	AZN1308	Spring	79	AZN1348	Cushion	
	30	AZN1309	Spring	80	AZN1349	Trigger arm	
	31	AZN1310	Spring	81	
	32	AZN1311	Spring	82	AZS1085	Solenoid	
	33	AZN1312	Spring	83	
	34	AZN1313	Spring	84	AZP1022	P Head	
	35	AZN1314	Spring	85	AZB1099	Screw	
	36	AZN1315	Spring	86	AZN1352	Spring	
	37	AZB1081	Screw	87	AZN1304	Spacer	
	38	AZN1316	Nylon band	88	AZN1470	Tube	
	39	AZN1995	P.C.board	89	AZB1100	Screw	
	40		Jumper wire	90	AZS1087	Solenoid	
	41		Wire assembly	91	AZB1101	Screw	
	42		Lead wire	92	AZB1102	Spring washer	
	43		Lead wire	93	AZN1471	Head spring	
	44	AZN1468	Tube	94	AZB1298	Screw	
	45		Mecha P.C.board calking assembly	95	AZN1833	Capstan holder	
	46	AZN1319	R reel assembly	96	AZN1834	Capstan holder	
	47	AZN1320	F reel assembly	97		Holder	
	48	AZN1321	Reverse arm calking assembly	200	AZB1084	Nut	
	49		FR lever assembly	201	AZB1085	E ring	
	50	AZN1975	PLAY lever calking assembly	202	AZB1086	D screw	
				203	AZB1121	P washer	
				204	AZB1087	N washer	

Mark	No.	Parts No.	Description
	205	AZB1089	U screw
	206	AZB1090	P washer
	207	AZB1091	Oil cut
	208	AZB1092	Oil cut
	209
A	210	AZB1094	P washer
	211	AZB1095	D screw
	212
	213	AZB1097	P washer
	214	AZB1098	M washer
	215	AZB1105	P screw
	216	AZB1106	D screw
	217
	218	AZB1164	P screw
	300	AZX1020	Motor assembly
	301	AZP1042	Head frame assembly

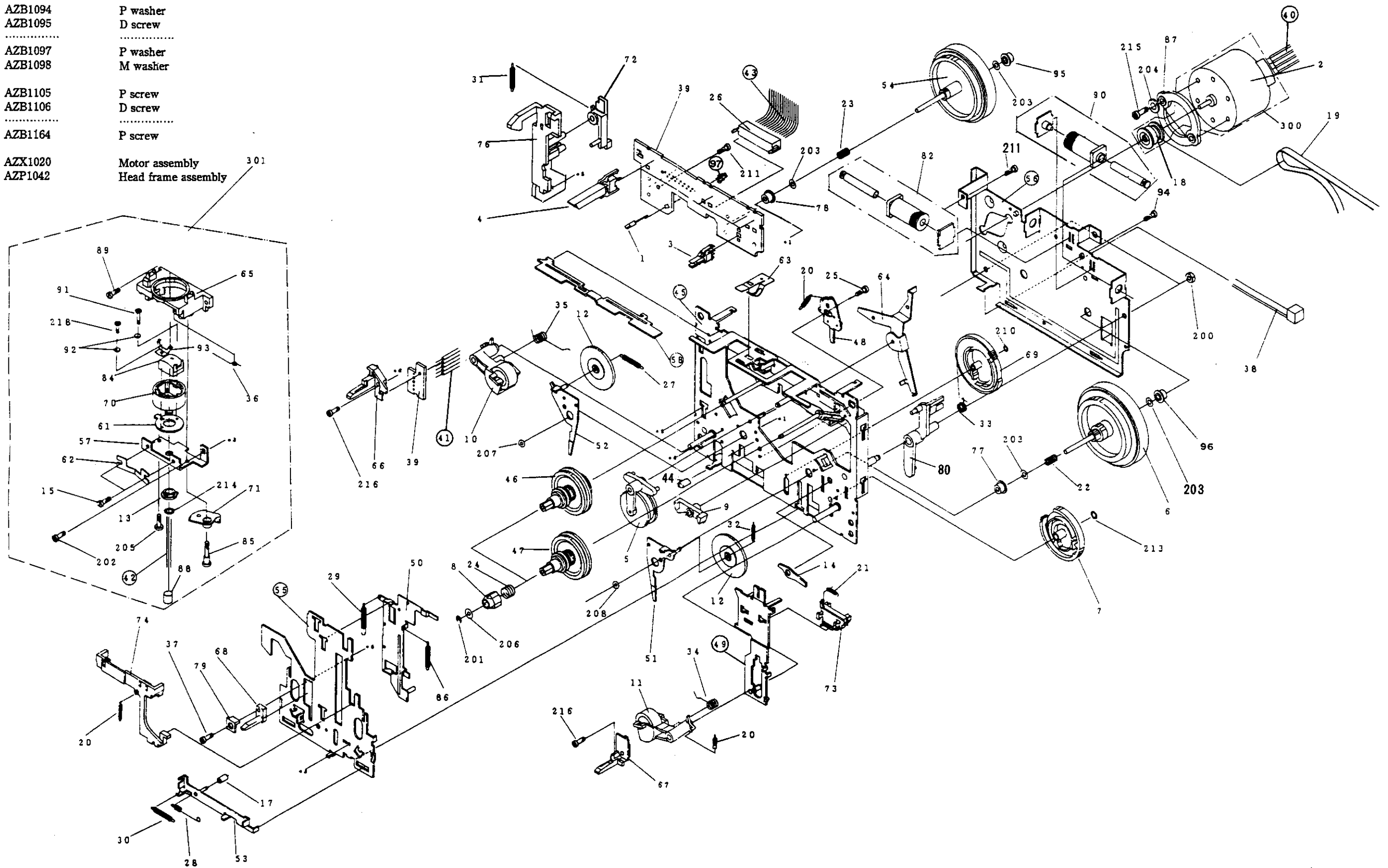

1.5 MECHA UNIT 2 (AWY1054)

Partslist of Mecha unit 2

Mark	No.	Parts No.	Description	Mark	No.	Parts No.	Description
	1	AZE1018	Hall IC		51	AZN1976	Gear arm R assembly
	2	AZX1019	Motor		52	AZN1977	Gear arm L assembly
	3	AZS1054	Leaf SW (MODE)		53	AZN1326	Head lever calking assembly
	4	AZS1034	Leaf SW (ARF, HALF, METAL, CrO2, ARR)		54	AZN1327	FW assembly
	5	AZN1286	Drive arm assembly		55		Head P.C.board
	6	AZN1287	FW assembly A		56		Plate (FLY WHEEL)
	7	AZN1288	Cam gear		57	AZN1328	Azimuth plate
	8	AZN1289	Reel		58		SW arm
	9	AZN1971	FR arm		59	AZN1988	Eject arm L
	10	AZN1972	Pinch roller L assembly		60	AZN1989	Eject arm R
	11	AZN1973	Pinch roller R assembly		61	AZN1330	Head arm
	12	AZN1293	Gear		62	AZN1331	Azimuth spring
	13	AZN1294	H Gear		63	AZN1332	Cassette stopper
	14	AZN1793	CUE arm		64	AZN1978	Trigger arm
	15	AZB1079	Screw		65	AZN1334	Head frame
	16	AZB1080	Screw		66	AZN1335	Cassette guide L
	17	AZN1984	Collar		67	AZN1336	Cassette guide R
	18	AZN1297	Motor pully		68	AZN1337	Cassette guide
	19	AZN1298	Belt		69	AZN1338	Cam gear
	20	AZN1299	Spring		70	AZN1979	Head holder
	21	AZN1300	FR lever spring		71	AZN1340	Head gear
	22	AZN1301	FWF spring		72	AZN1980	Eject arm 2
	23	AZN1302	FWR spring		73	AZN1342	Select lever
	24	AZN1303	Spring		74	AZN1343	Brake
	25	AZB1080	Screw		75	AZN1468	Tube
	26	AZN1305	Cable holder		76	AZN1985	Ratch lever R
	27	AZN1306	Spring		77	AZN1346	Metal
	28	AZN1307	Spring		78	AZN1347	Metal
	29	AZN1308	Spring		79	AZN1348	Cushion
	30	AZN1309	Spring		80	AZN1349	Trigger arm
	31	AZN1310	Spring		81
	32	AZN1311	Spring		82	AZS1085	Solenoid
	33	AZN1312	Spring		83
	34	AZN1313	Spring		84	AZP1014	R/P/E Head
	35	AZN1314	Spring		85	AZB1099	Screw
	36	AZN1315	Spring		86	AZN1352	Spring
	37	AZB1081	Screw		87	AZN1304	Spacer
	38	AZN1316	Nylon band		88	AZN1470	Tube
	39	AZN1983	P.C.board		89	AZB1100	Screw
	40		Jumper wire		90	AZS1087	Solenoid
	41		Head lead		91	AZB1101	Screw
	42		Lead wire		92	AZB1102	Spring washer
	43		Wire		93		...
	44		94	AZB1298	Screw
	45		Mecha P.C.board calking assembly		95	AZN1833	Capstan holder
	46	AZN1319	R reel assembly		96	AZN1834	Capstan holder
	47	AZN1320	F reel assembly		97	AZN1344	Eject lever L
	48	AZN1321	Reverse arm calking assembly		98
	49		FR lever assembly		99		Holder
	50	AZN1975	PLAY lever calking assembly				

Mark	No.	Parts No.	Description
	200	AZB1084	Nut
	201	AZB1085	E ring
	202	AZB1086	D screw
	203	AZB1121	P washer
	204	AZB1087	N washer
A	205	AZB1089	U screw
	206	AZB1090	P washer
	207	AZB1091	Oil cut
	208	AZB1092	Oil cut
	209
	210	AZB1094	P washer
	211	AZB1095	D screw
	212
	213	AZB1097	P washer
	214	AZB1098	M washer
	215	AZB1105	P screw
	216	AZB1106	D screw
	300	AZX1020	Motor assembly
	301	AZP1041	Head frame assembly

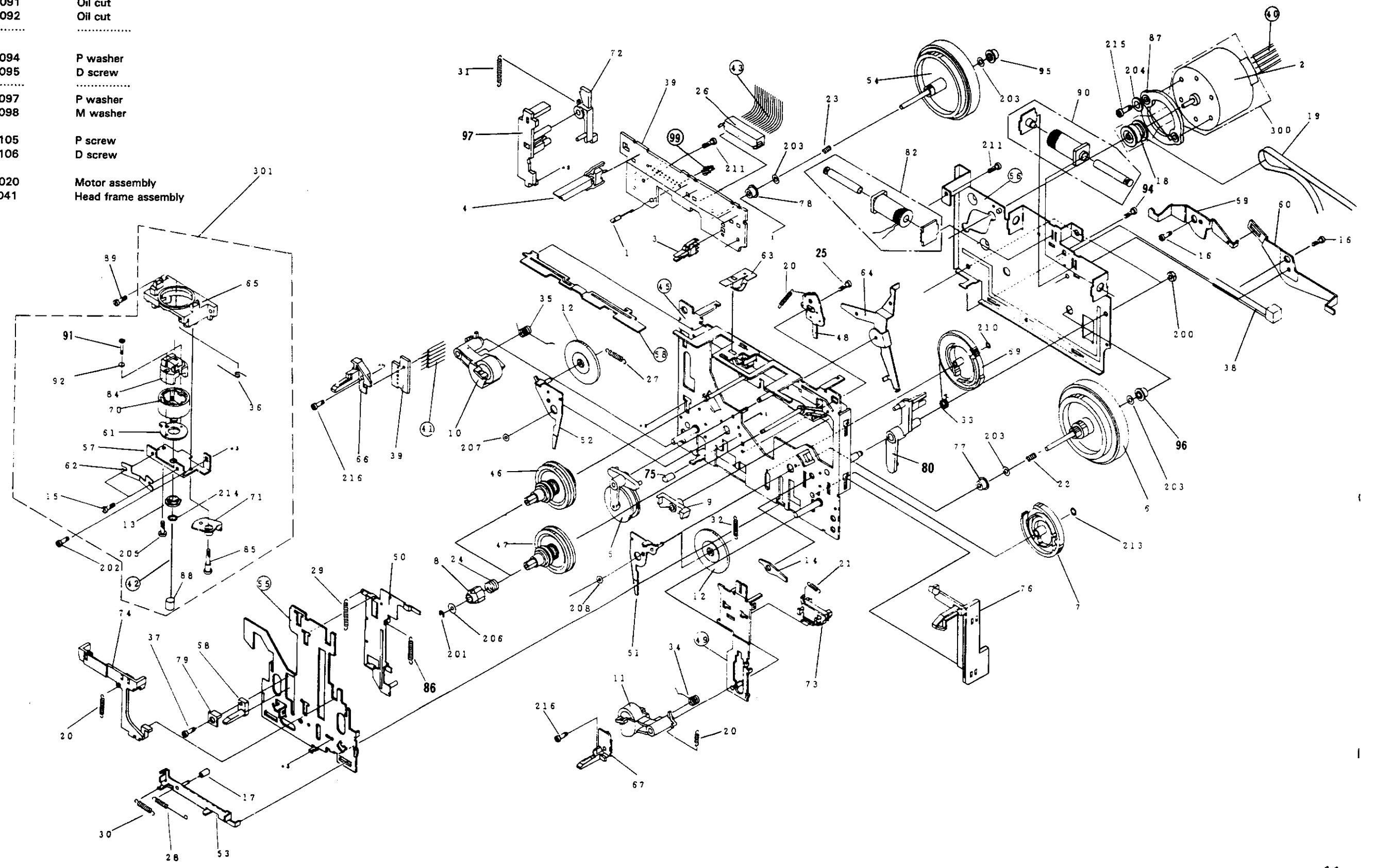

2. SCHEMATIC DIAGRAMS AND P.C.BOARD CONNECTION DIAGRAMS

2.1 OVER ALL SCHEMATIC DIAGRAM

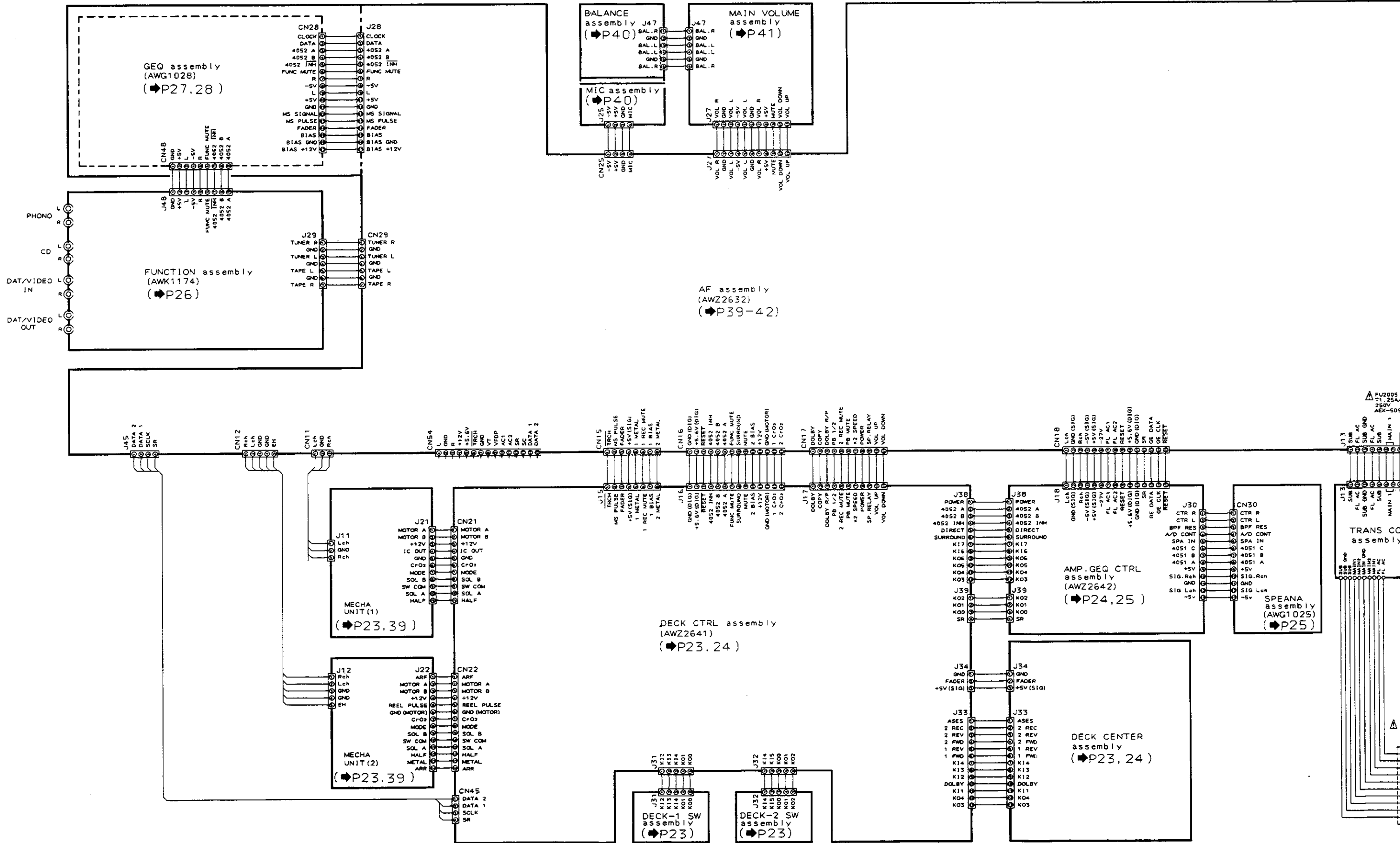

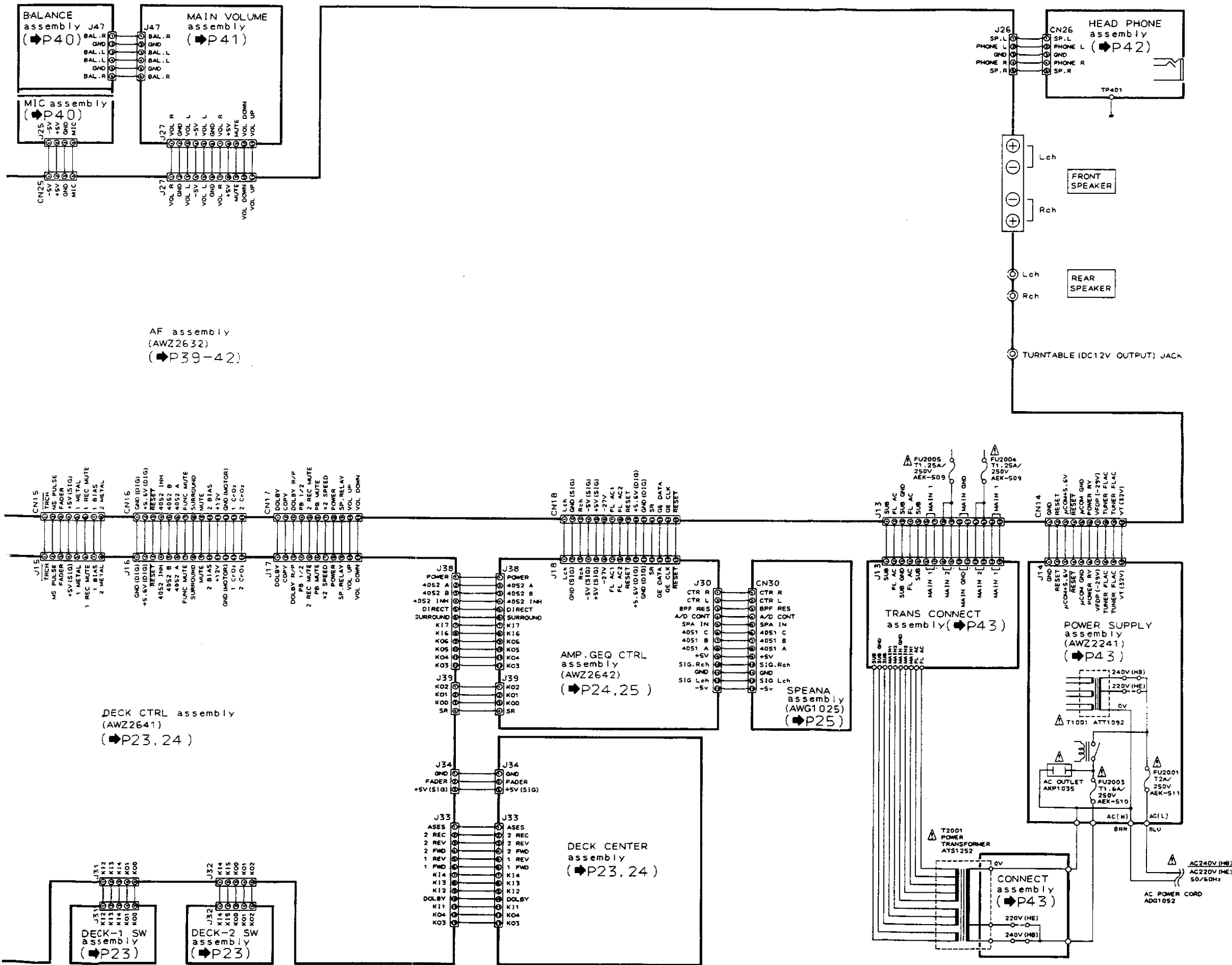

1. RESISTORS:
 Indicated in Ω, %W, %W, ±5% tolerance unless otherwise noted k: kΩ,
 M: MΩ, (F): ±1%, (G): ±2%, (K): ±10% (M): ±20% tolerance

2. CAPACITORS:
 Indicated in capacity (μF)/voltage (V) unless otherwise noted p: pF
 Indication without voltage is 50V except electrolytic capacitor.

3. VOLTAGE, CURRENT:
 [Symbol] : Signal voltage at (45W + 45W 8Ω)output (1kHz)
 [Symbol] : DC voltage (V) at no input signal
 Value in () is DC voltage at rated power.
 [Symbol] mA: DC current at no input signal

4. OTHERS:
 [Symbol] : Signal route.
 [Symbol] : Adjusting point.
 The [Symbol] mark found on some component parts indicates the importance of the safety factor of the part. Therefore, when replacing, be sure to use parts of identical designation.
 * marked capacitors and resistors have parts numbers.

This is the basic schematic diagram, but the actual circuit may vary due to improvements in design.

SWITCHES:

AMP,GEQ CTRL assembly	DECK-1 SW assembly
S707 PHONO	S811 1FWD
S709 TUNER	S812 1REV
S715 DAT	S813 1FF
S718 CD	S814 1REV
S719 SURROUND	S815 1STOP
S720 POWER	DECK-2 SW assembly
S721 CD DIRECT	S821 2FWD
S722 TAPE	S822 2REV
S771 60Hz +	S823 2FF
S772 150Hz +	S824 2REV
S773 400Hz +	S825 2STOP
S774 1kHz +	DECK CENTER assembly
S775 2.4kHz +	S848 DOLBY OFF-ON
S776 6kHz +	S849 REVERSE MODE
S777 15kHz +	S853 COPY
S778 60Hz -	S857 FADER
S779 150Hz -	S862 HI-SPEED COPY
S780 400Hz -	S871 DECK-2 MUTE
S781 1kHz -	S872 A.S.E.S
S782 2.4kHz -	S874 DECK-2 REC
S783 6kHz -	S875 DECK-2PAUSE
S784 15kHz -	
S785 A	
S786 B	
S787 C	
S788 D	
S789 E	
S790 PRESET/MEMORY	
S791 EQUALIZER ON/OFF	
S792 FLAT/REVERSE	
S793 MEMORY	

The underline indicates the switch position

A

B

C

D

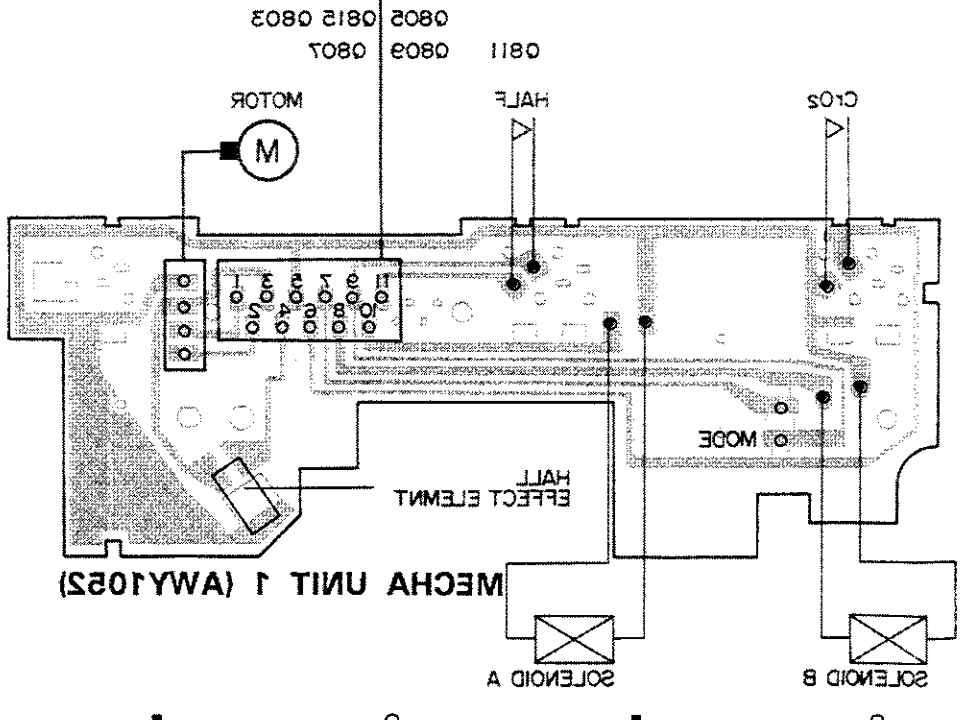
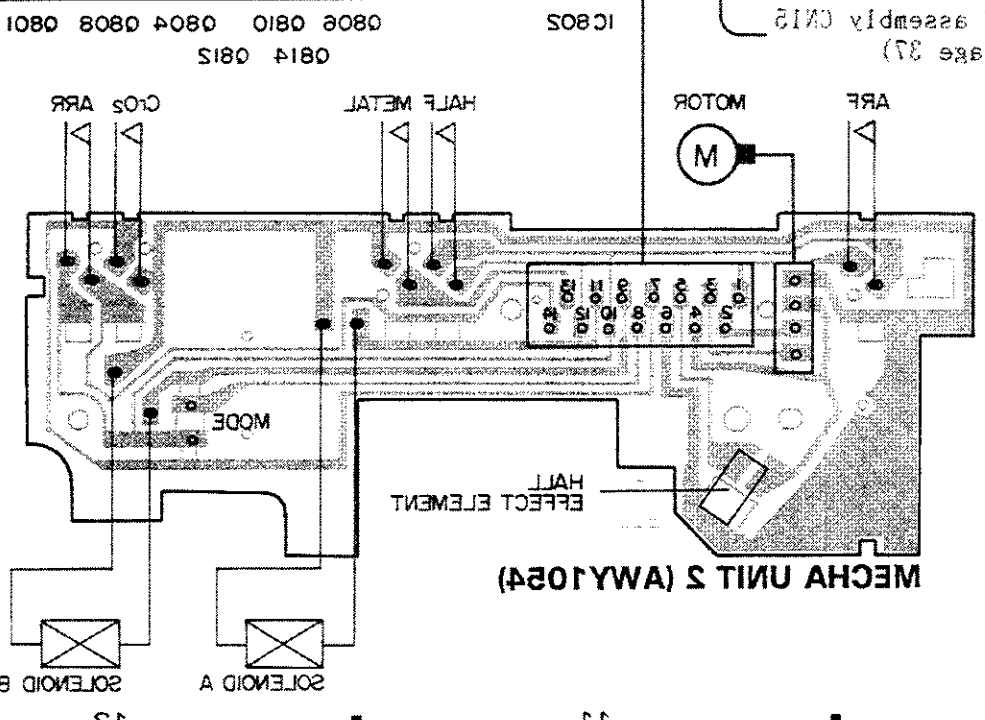
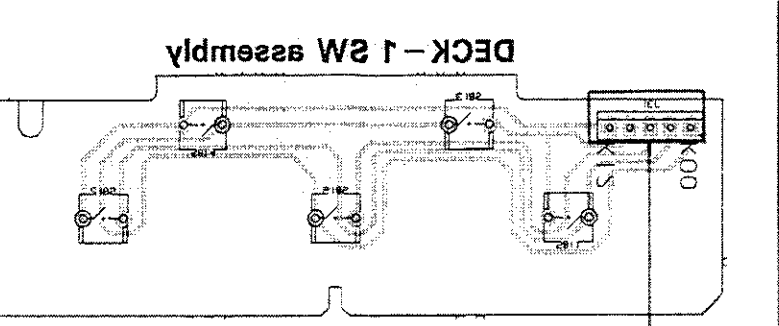
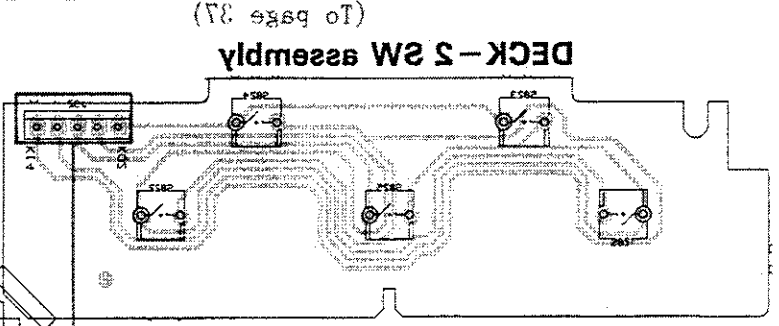
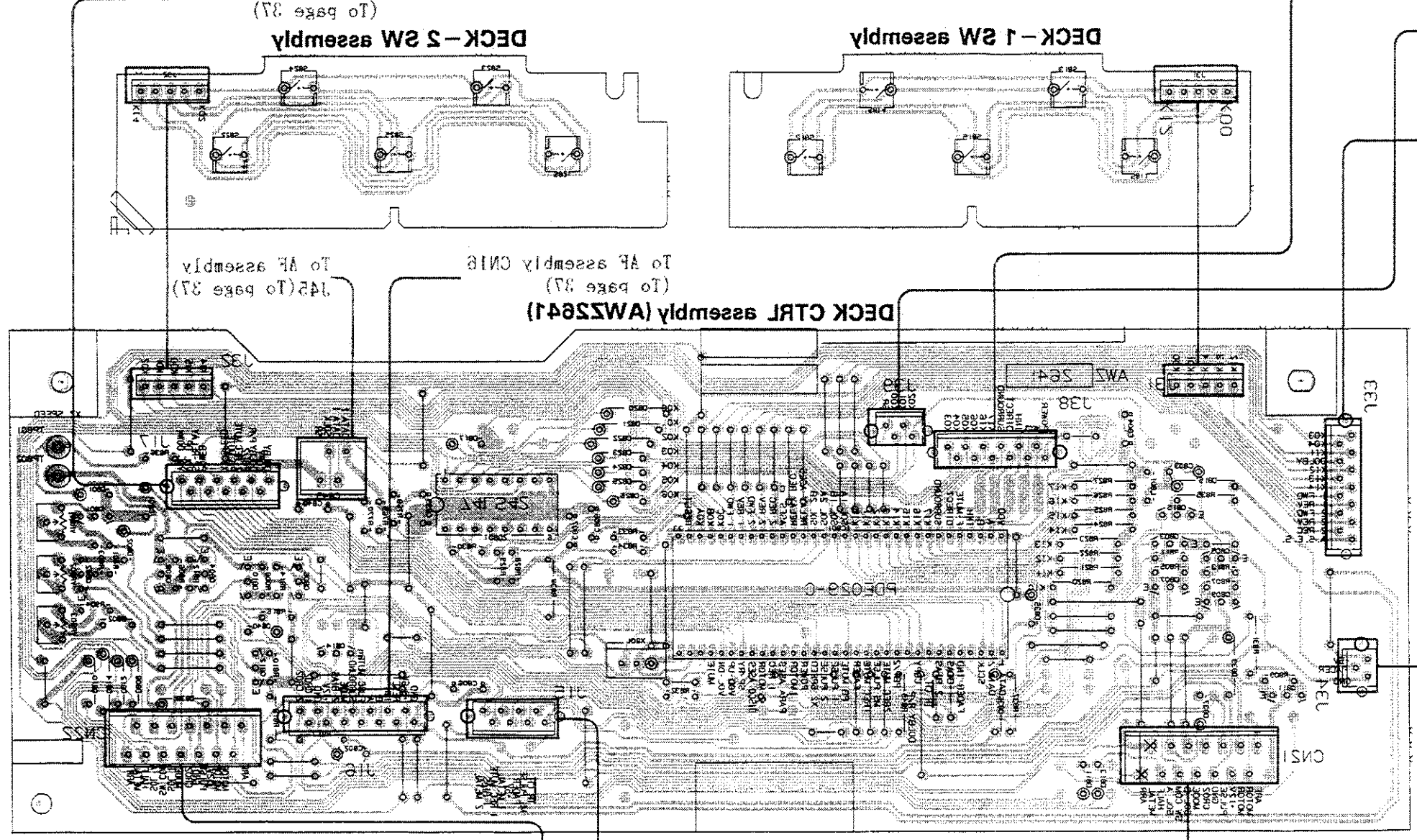
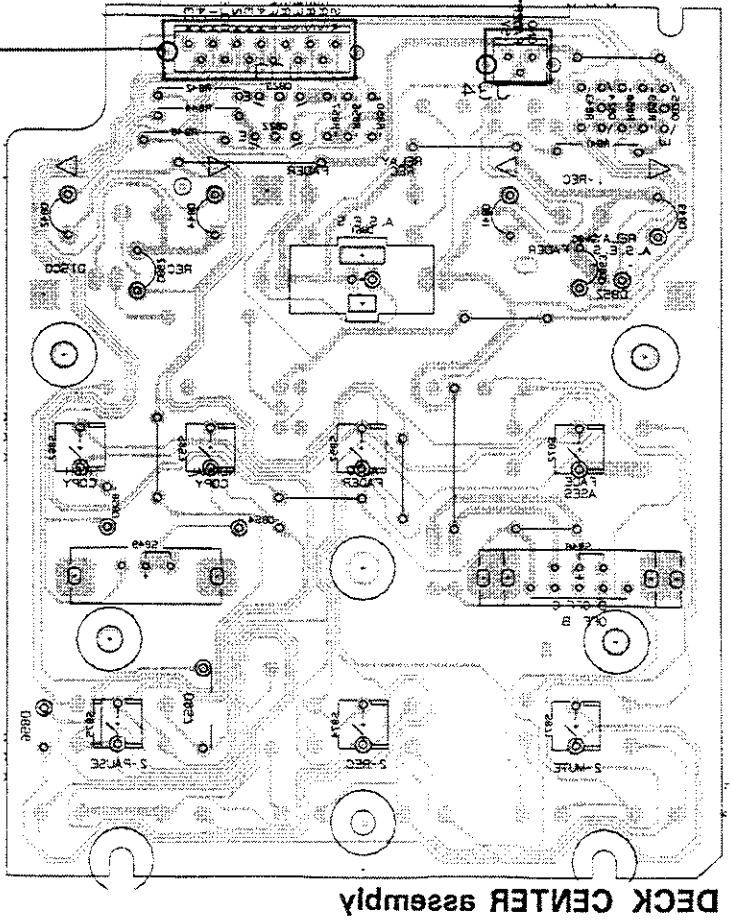

IC801 To AF assembly CN15 (To page 37)
 IC802 0815 0803
 IC803 0809 0803
 IC804 0815 0803
 IC805 0808 0810 0804 0808 0801 0805
 VR801-VR803

To AF assembly CN17 (To page 37)

To AF assembly (To page 37)

To AF assembly CN18 (To page 37)

DECK CTRL assembly (AW2841)

DECK -1 SW assembly

DECK -2 SW assembly

DECK CENTER assembly

MECHA UNIT 2 (AWY1054)

MECHA UNIT 1 (AWY1053)

SOLENOID A
 SOLENOID B

SOLENOID A
 SOLENOID B

EFFECT ELEMENT
 HALL

EFFECT ELEMENT
 HALL

CLOS ARR

HALF METAL

MOTOR

ARR

MOTOR

HALF

CLOS

MODE

MODE

15

11

10

9

8

7

15

11

10

9

8

7

2.2 AMP, GEQ CTRL (AWZ2642), DECK-1 SW, DECK-2 SW, DECK CTRL (AWZ2641), DECK CENTER, SPEANA assembly (AWG1025) MECHA UNIT 1 (AWY1052) and MECHA UNIT 2 (AWY1054)

A

To AF assembly CN18
(To page 36)

B

C

D

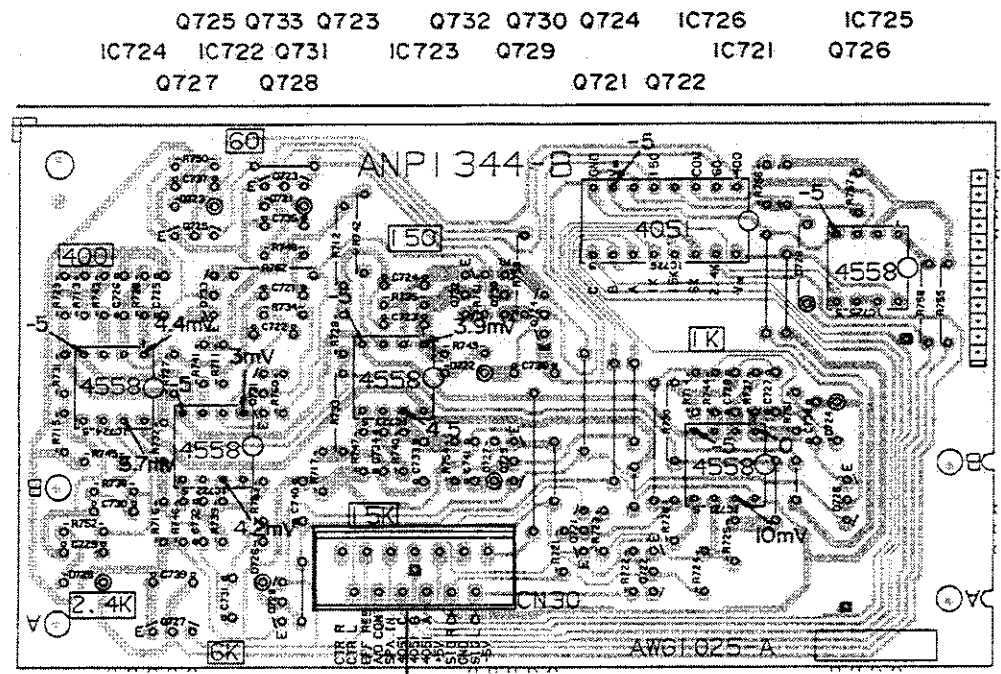
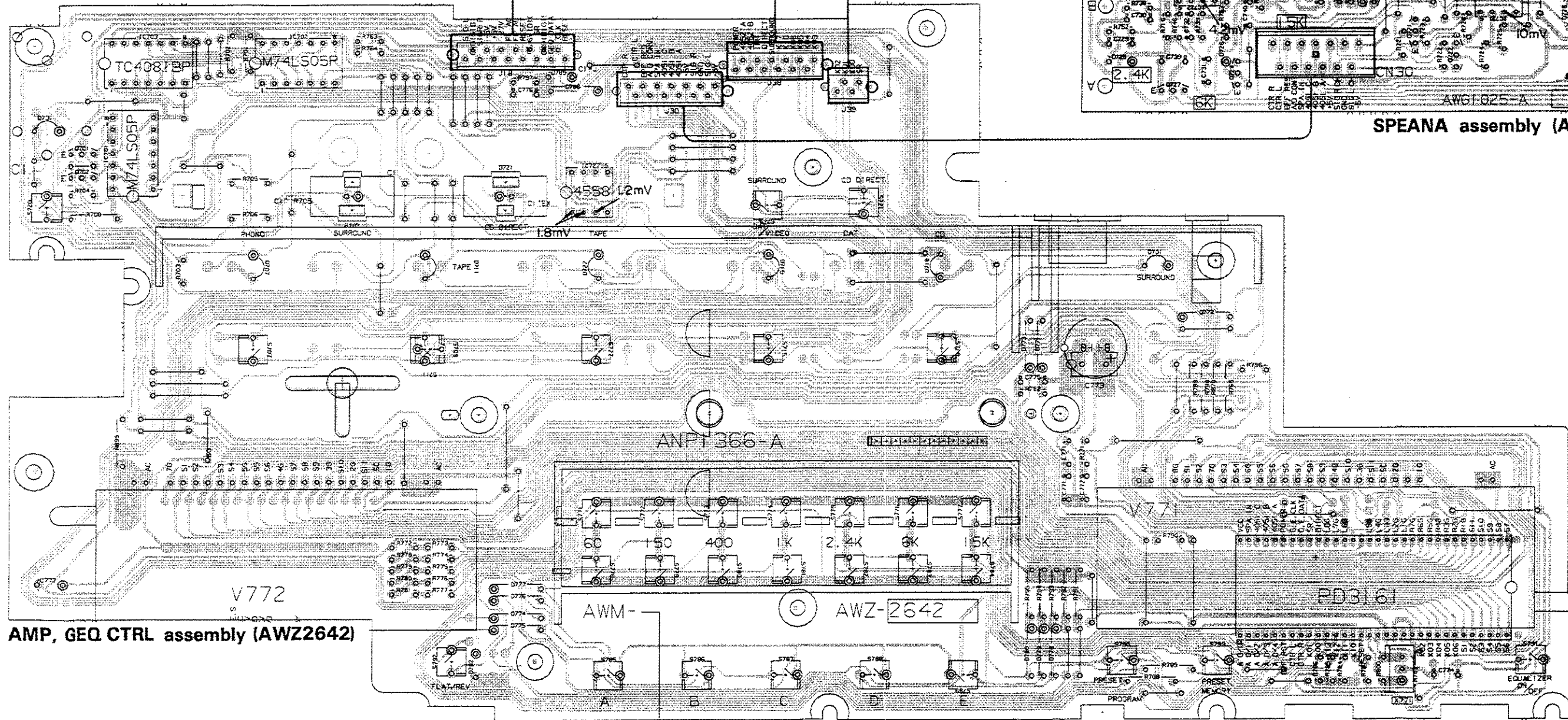

SPEANA assembly (AWG1025)



DECK CTRL

- NOTE
1. This P.C.B. connection diagram is viewed from the top.
 2. The parts which have been mounted on the P.C.B. are indicated by the corresponding wiring symbols listed below.

P.C.B. pattern diagram indication	Corresponding wiring symbol
EO	⊙
O215	⊕
O203	⊖
R237	⊖
C513	⊕
C518	⊖

Others

P.C.B. pattern diagram indication	Part
IC	IC
S	S
RV	RV
L	L
F	F
VR	Var. Semi

3. The capacitor terminal marked with ⊕ (double circle) is to be connected to ground.
4. The diode terminal marked with ⊕ (double circle) is to be connected to ground.
5. The transistor terminal to which E is affixed is to be connected to ground.

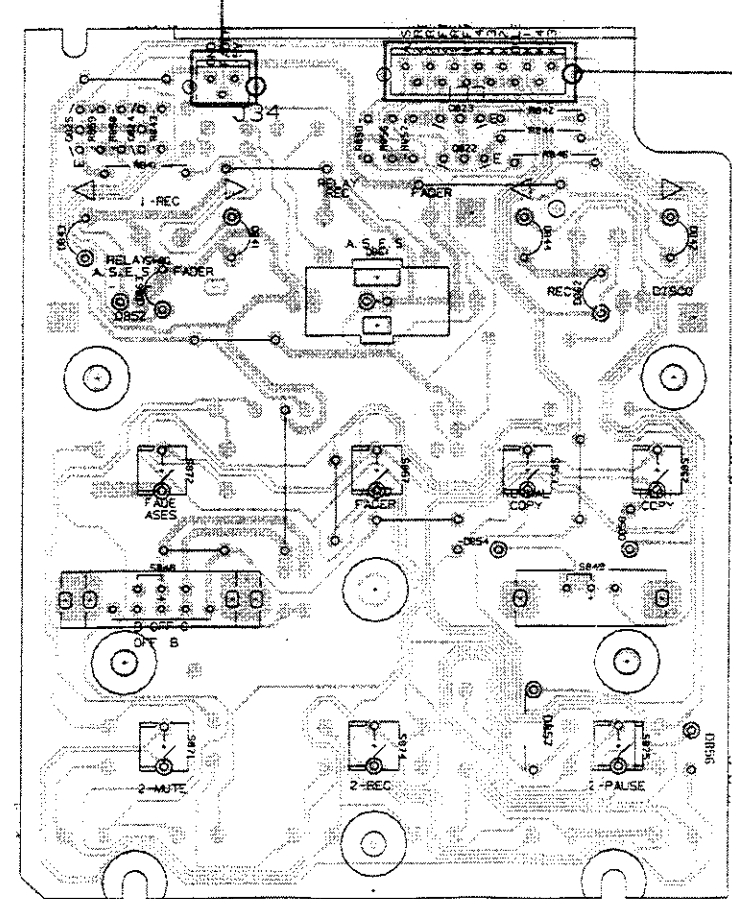

DECK CENTER assembly

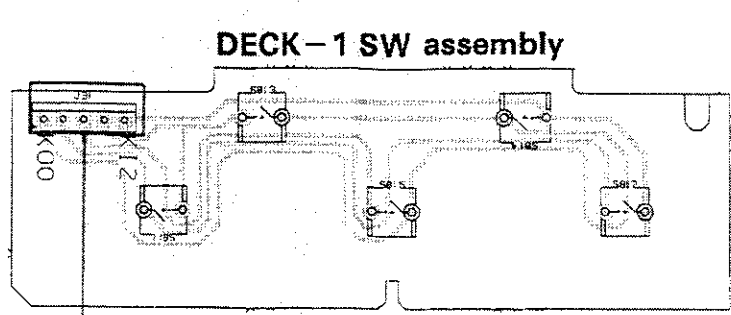

DECK-1 SW assembly

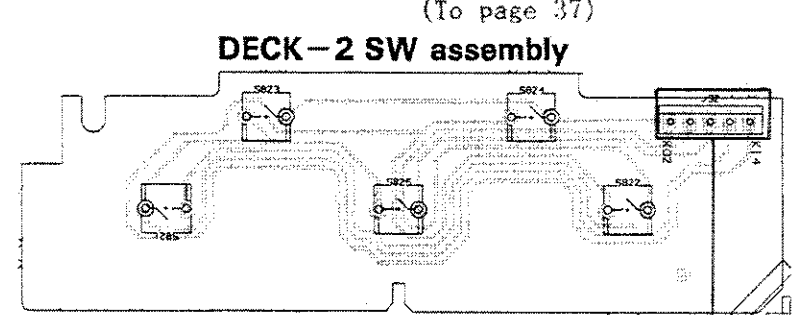

DECK-2 SW assembly

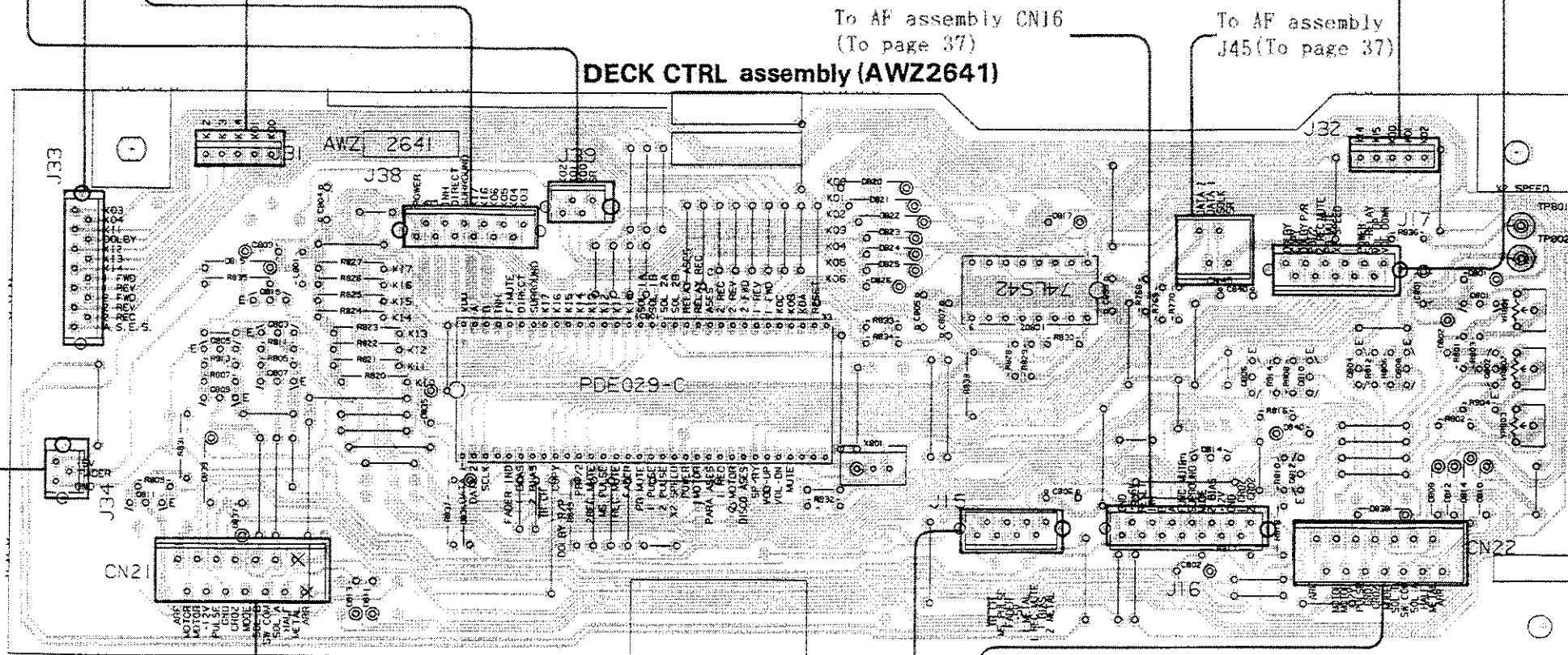

DECK CTRL assembly (AWZ2641)

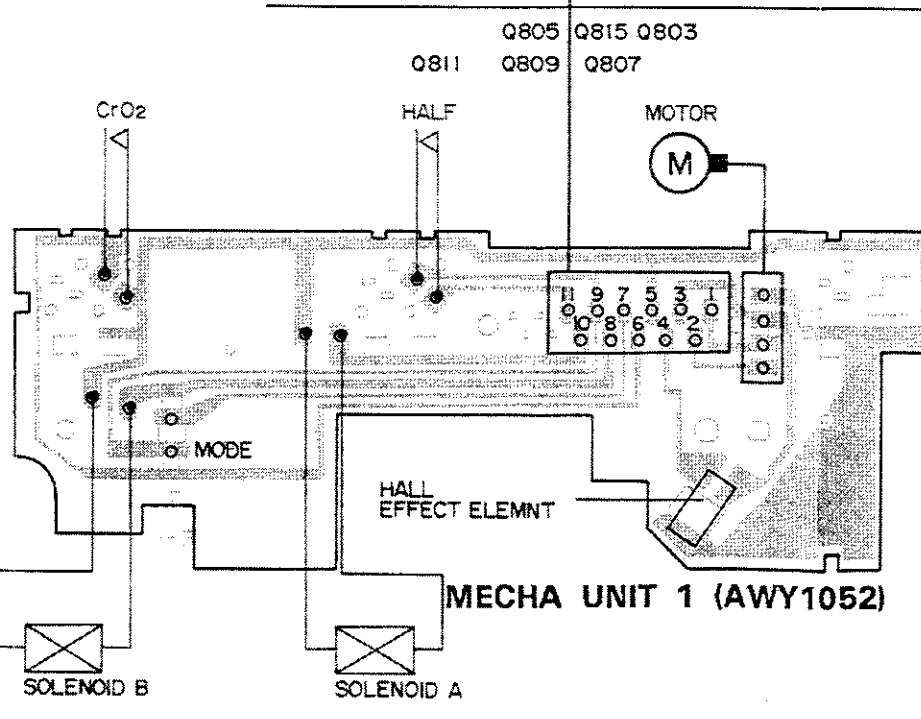

MECHA UNIT 1 (AWY1052)

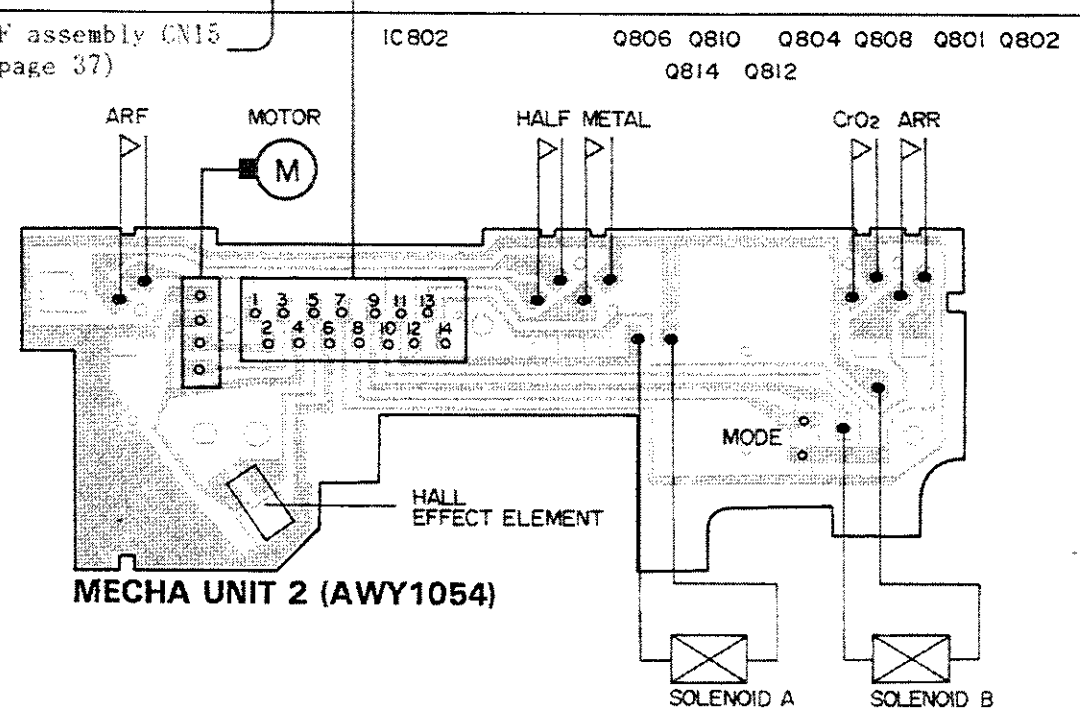

MECHA UNIT 2 (AWY1054)

NOTE

1. This P.C.B. connection diagram is viewed from the parts mounted side.
2. The parts which have been mounted on the board can be replaced with those shown with the corresponding wiring symbols in the following Table.

P.C.B. pattern diagram indication	Corresponding part symbol	Part Name
		Transistor
		Radiator type transistor
		Diode
		Resistor
		Capacitor (Polarity)
		Capacitor (Non-polarity)

Others

P.C.B. pattern diagram indication	Part Name
IC	IC
S	Switch
RY	Relay
L	Coil
F	Filter
VR	Variable resistor or Semi-fixed resistor

3. The capacitor terminal marked with @ (double circles) shows negative terminal.
4. The diode terminal marked with @ (double circles) shows cathode side.
5. The transistor terminal to which E is affixed shows the emitter.

DECK CTRL assembly (AWZ2641)

MECHA UNIT(1)

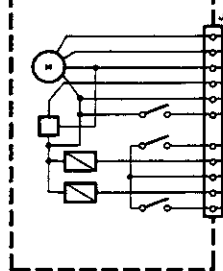

MECHA UNIT(2)

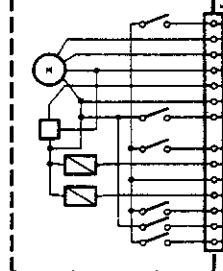

DECK 1 SW assembly

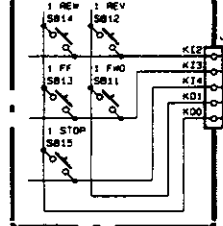

DECK-2 SW assembly

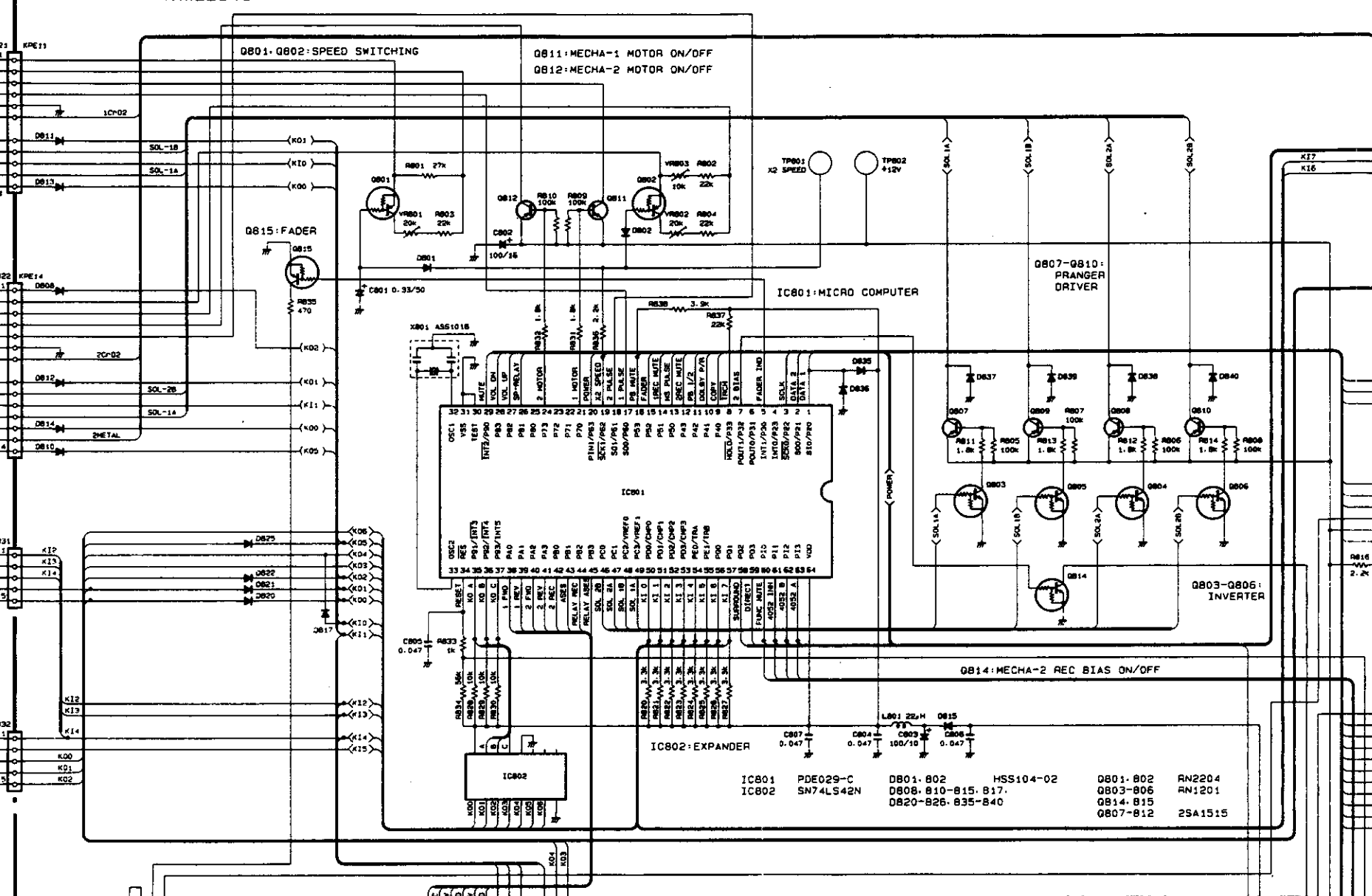
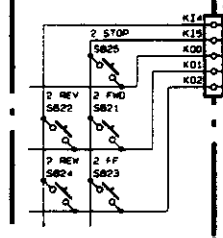

DECK CENTER assembly

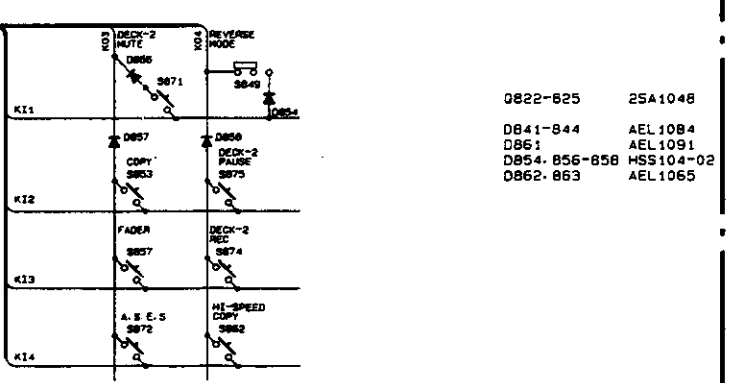
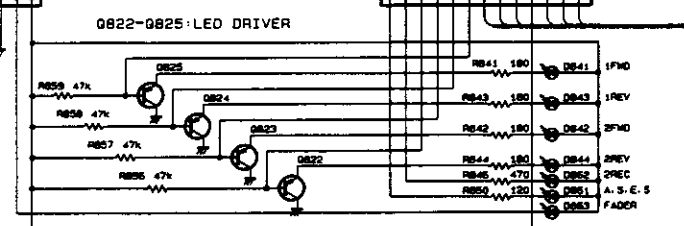

- 0822-825 25A1048
- 0841-844 AEL1084
- 0861 AEL1091
- 0854-856-858 HSS104-02
- 0862-863 AEL1065

AMP. GEQ CTRL assembly (AWZ2641)

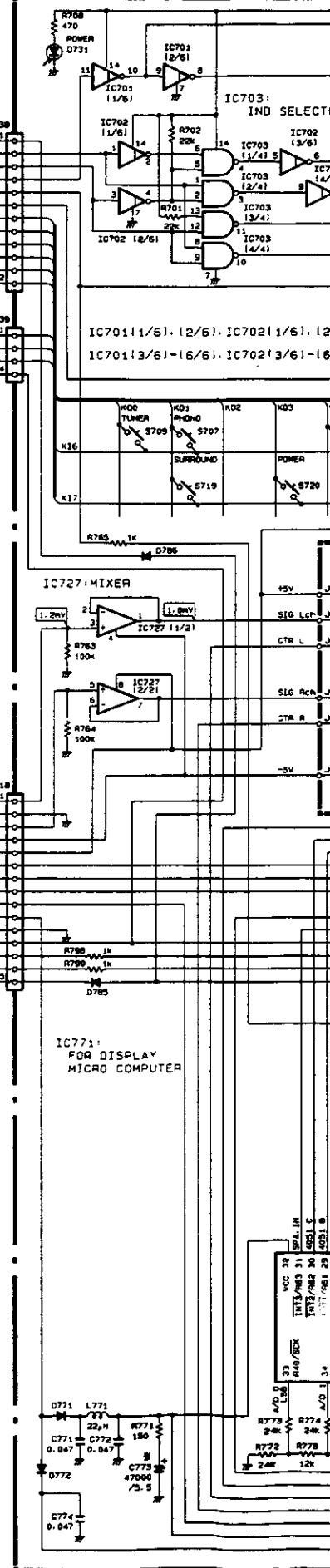

A

B

C

D

3 4 5 6 7 8 9

-1 MOTOR ON/OFF
-2 MOTOR ON/OFF

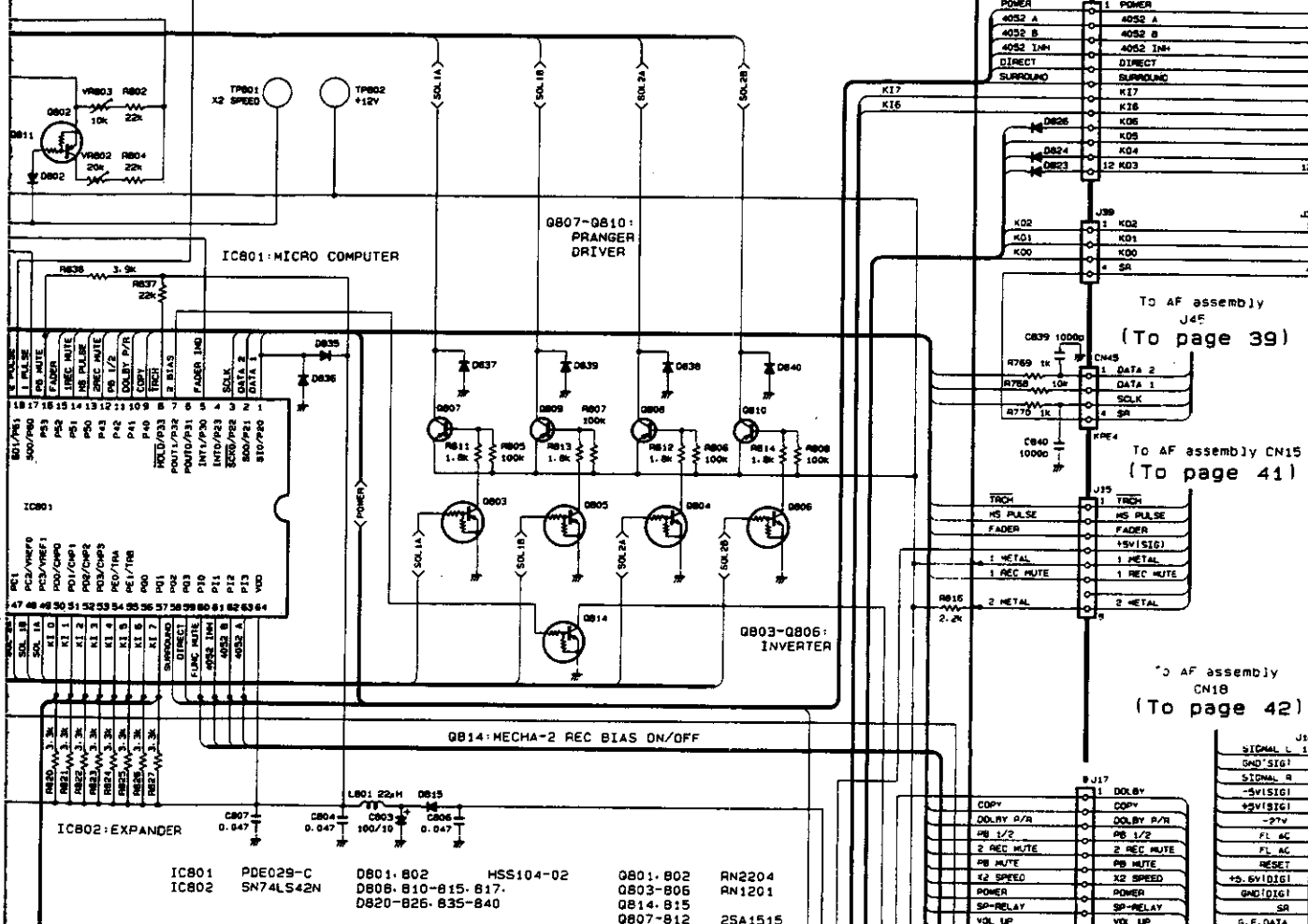

DECK CENTER assembly

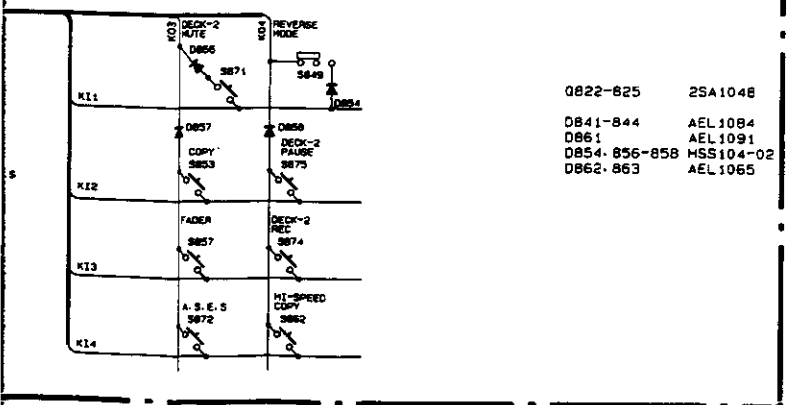

Q822-825	2SA1048
Q841-844	AEL1084
Q861	AEL1091
Q854-856-858	HSS104-02
Q862-863	AEL1065

AMP. GEG CTFL assembly (AWZ2642)

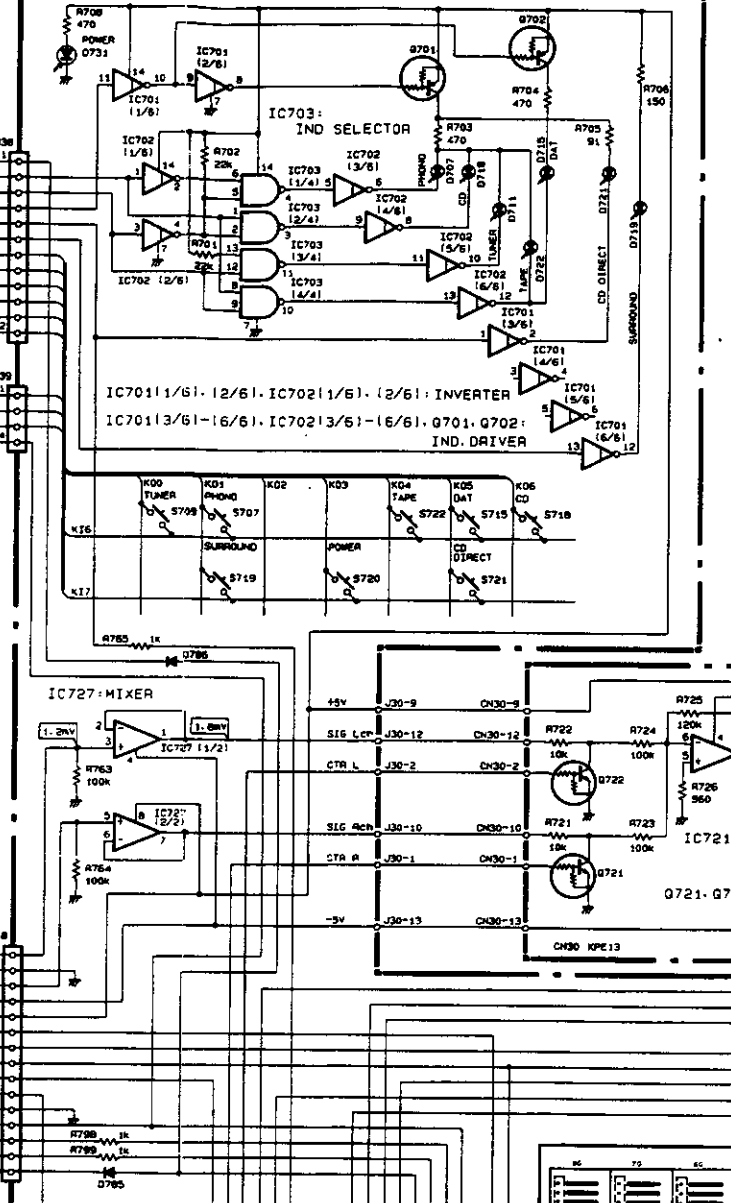

IC771: FOR DISPLAY MICRO COMPUTER

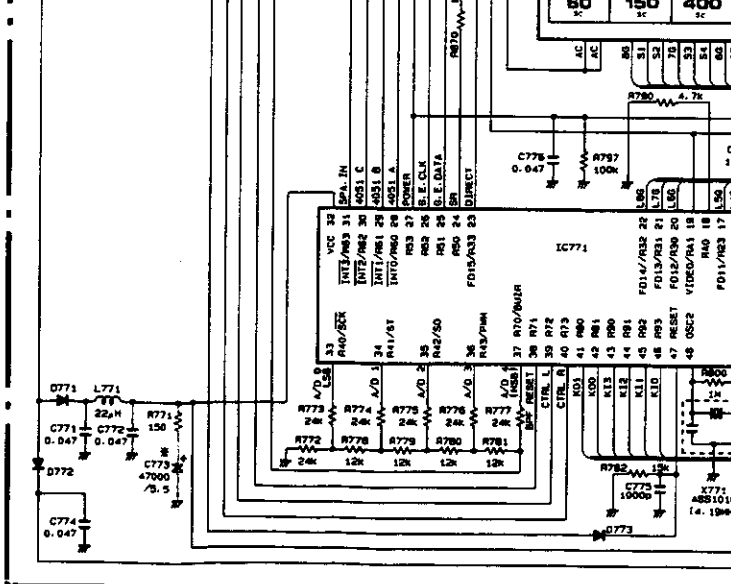

SPEANA assembly (AWG1025)

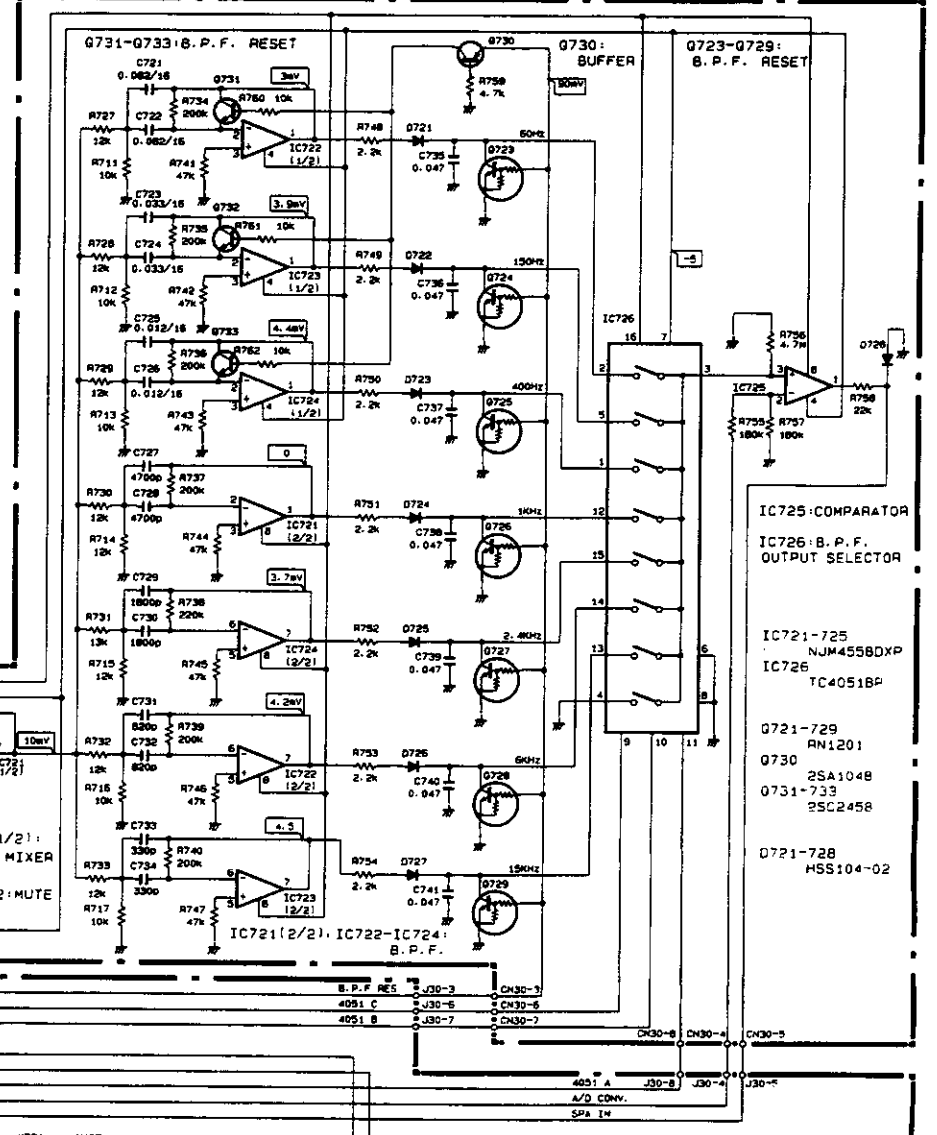

IC701, 702	M74LS05N	D721	M74LS05N	AEL1081
IC703	TC4081BP	D707, 711, 715,	D707, 711, 715,	AEL1099
IC727	NJM4558DXP	D718, 722, 731	D718, 722, 731	
IC771	PD3133-C	D719	D719	AEL1105
Q701-702	AN2201	D771-780,	D771-780,	HSS104-02
		D782, 785, 786	D782, 785, 786	

3 4 5 6 7 8 9 25

2.3 FUNCTION (AWK1174) and GEQ assembly (AWG1028)

A

MECHA-2 Lch PLAY
MECHA-2 Rch REC

B

C

D

FUNCTION assembly (AWK1174)

LOGICAL TABLE IN TC4052BP

FUNCTION	A	B	INH
CD	H	L	L
PHONO	L	L	L
TAPE	H	H	L
TUNER	L	H	L

- IC901: 904 NJM4558DXP
- IC902 TC4052BP
- IC903 TC4066BP
- Q901: 903 DTA143ES
- Q902 DTC143ES
- D901 HSS104-02

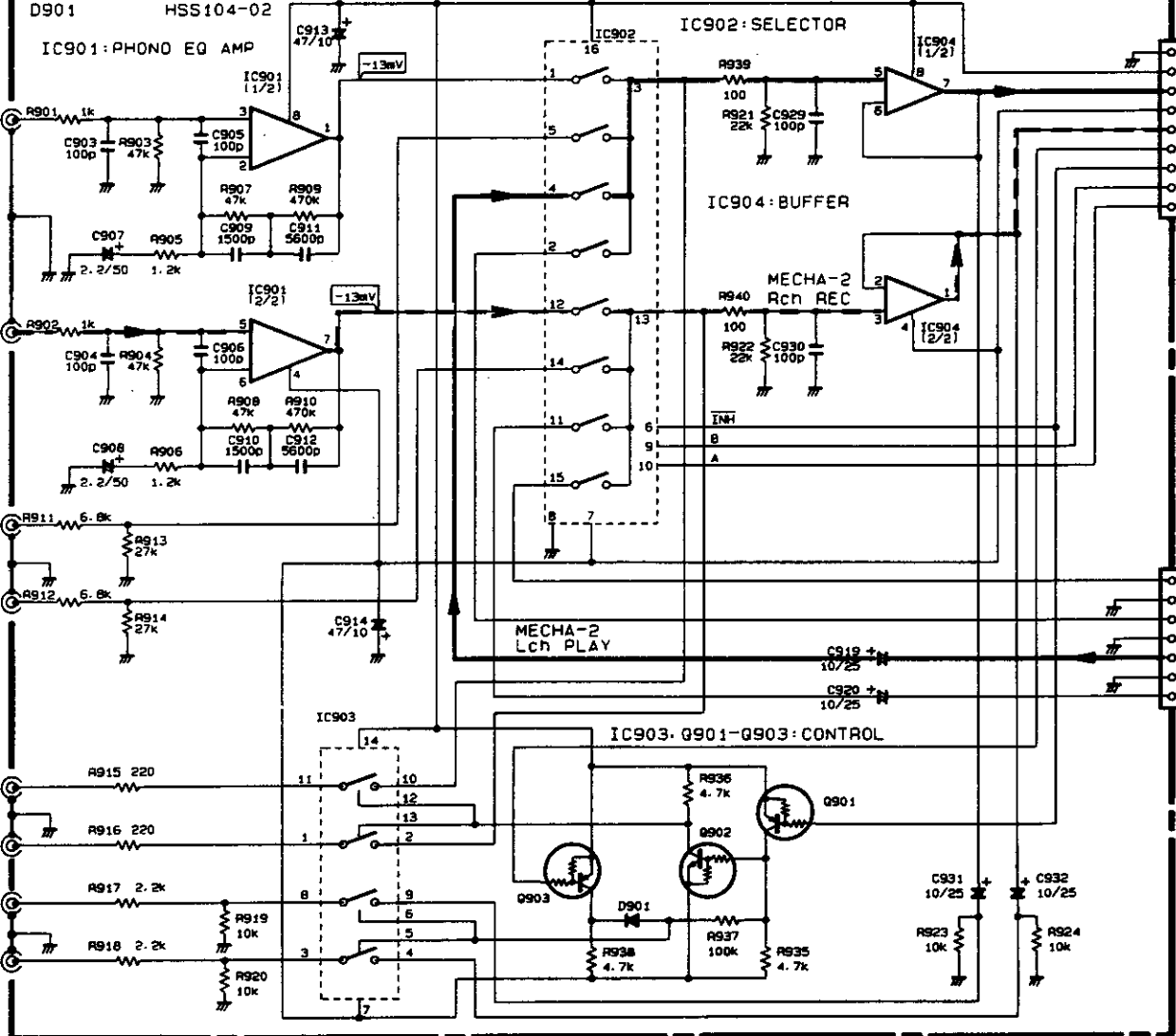

To AF assembly
CN29
(To page 39)

GEQ assembly (AWG1028)*

*:The GEQ assembly is the sub P.C.board which is part of the AF assembly

IC601, IC602: SEMICONDUCTOR INDUCTOR (FOR BAND PASS FILTER)

IC603: ELECTRIC VOLUME

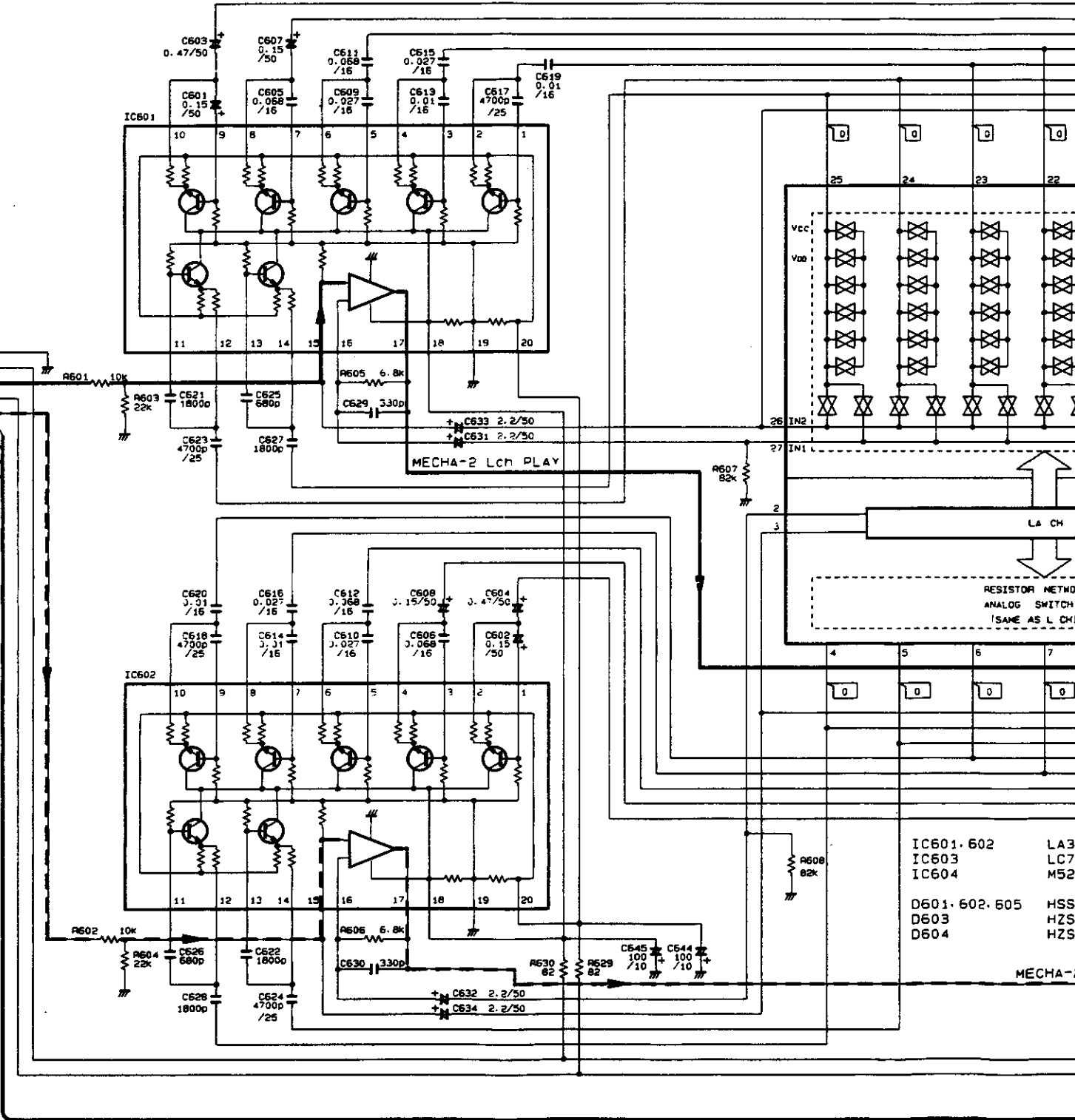

GEO assembly (AWG1028)*

*:The GEO assembly is the sub P.C-board which is part of the AF assembly.

IC601, IC602: SEMICONDUCTOR INDUCTOR (FOR BAND PASS FILTER)

IC603: ELECTRIC VOLUME (FOR GRAPHIC EQ)

IC604: MS DETECT

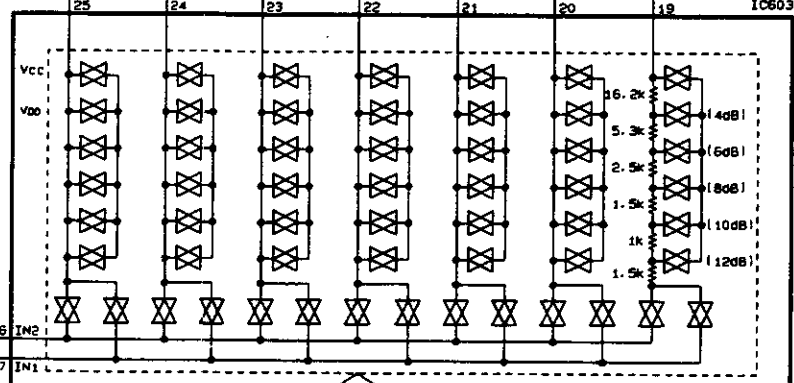
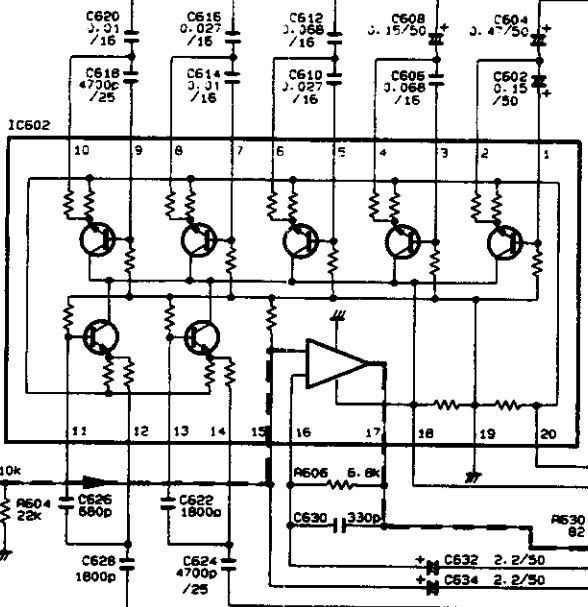
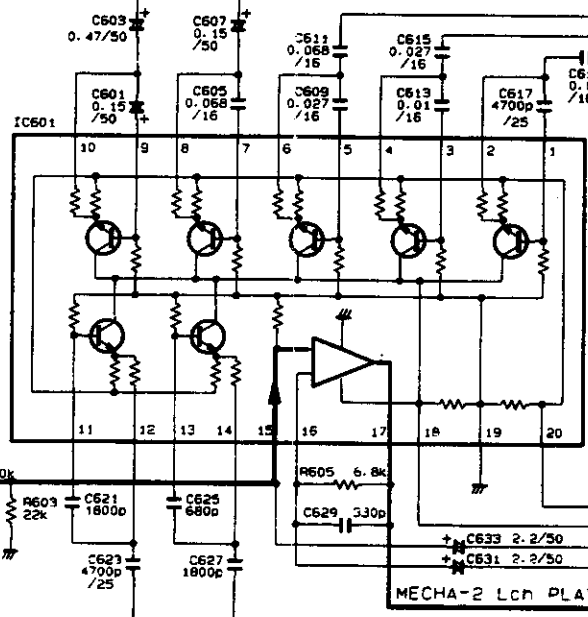
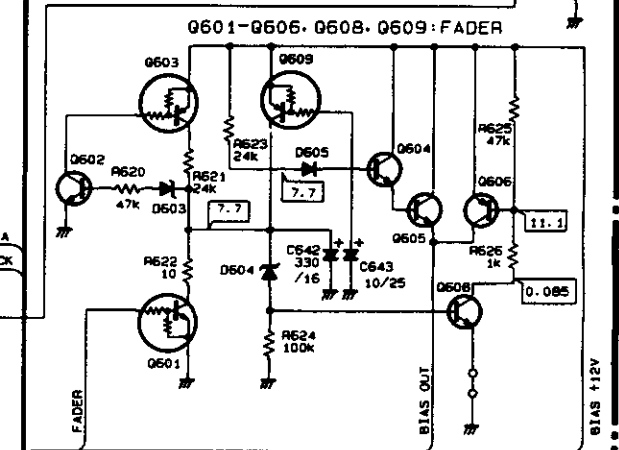
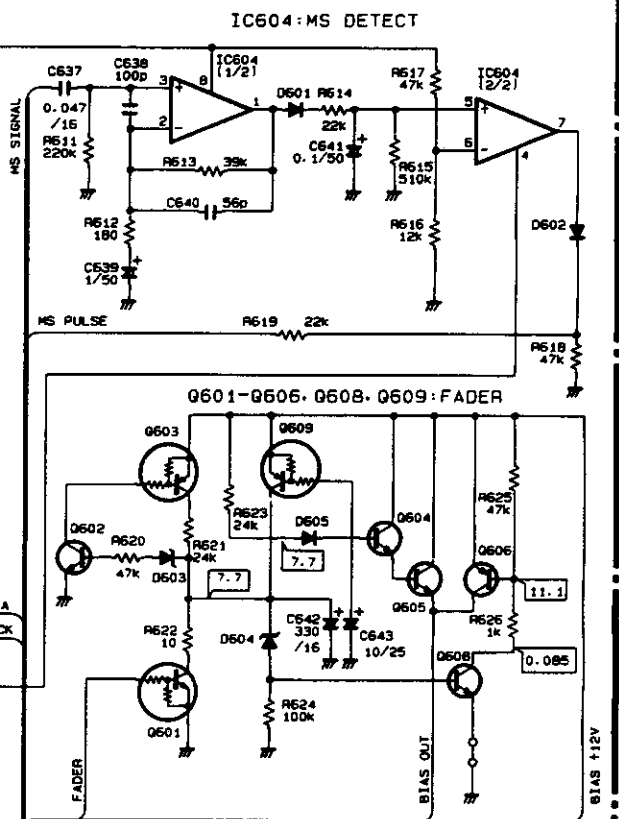

IC601, 602	LA3607	Q601	AN1201
IC603	LC7522	Q602, 608	2SC2458
IC604	M5218L	Q603	RN2204
D601, 602, 605	HSS104-02	Q604, 605	2SC2603
D603	HZS5ALL	Q606	2SA1115
D604	HZS7B2L	Q609	RN2203

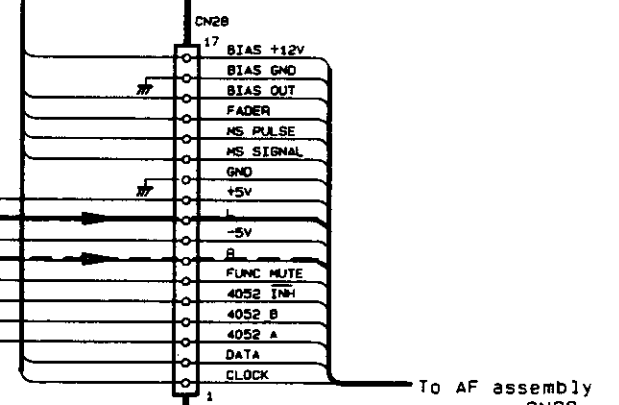
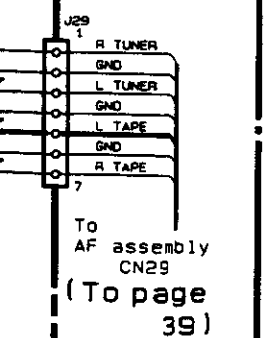
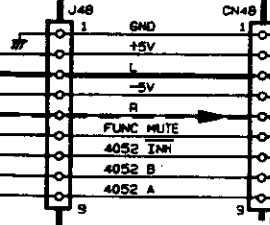

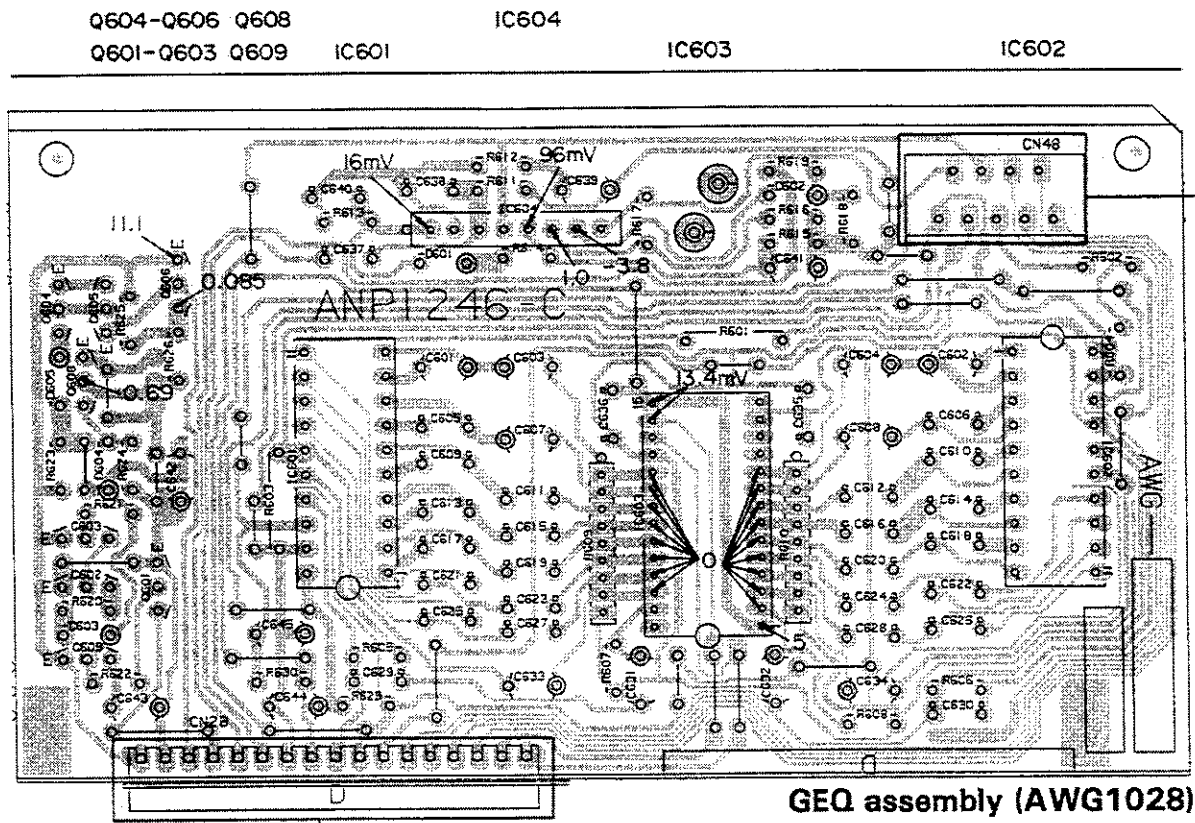

GEQ assembly (AWG1028)

To AF assembly CN28
(To page 37)

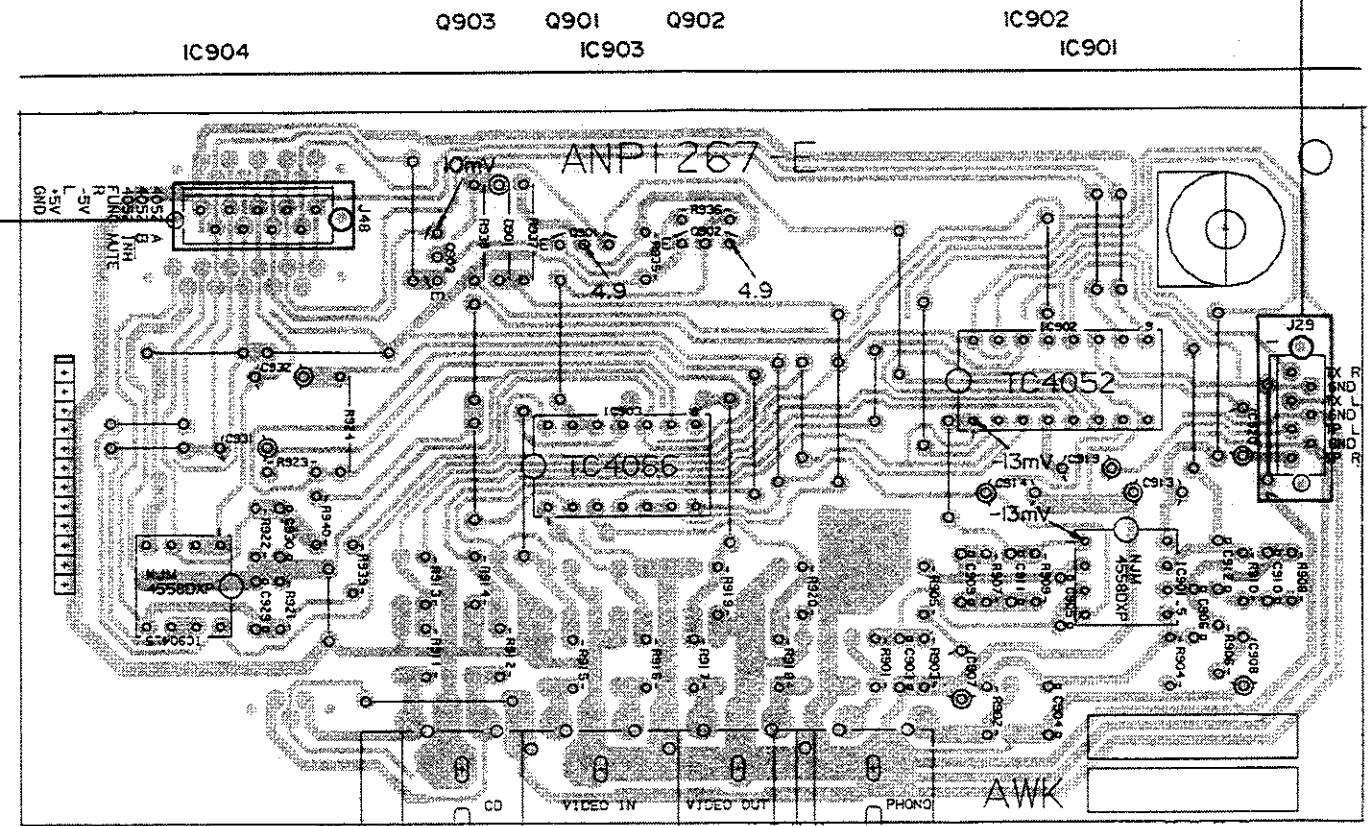

FUNCTION assembly (AWK1174)

- NOTE
1. This P.C.B. connection diagram is viewed from the parts mounted side.
 2. The parts which have been mounted on the board can be replaced with those shown with the corresponding wiring symbols listed in the following Table.

P.C.B. pattern diagram indication	Corresponding part symbol	Part Name
		Transistor
		Radiator type transistor
		Diode
		Resistor
		Capacitor (Polarity)
		Capacitor (Non-polarity)

Others

P.C.B. pattern diagram indication	Part Name
IC	IC
S	Switch
RV	Relay
L	Coil
F	Filter
VR	Variable resistor or Semi-fixed resistor

3. The capacitor terminal marked with ⊖ (double circles) shows negative terminal.
4. The diode terminal marked with ⊖ (double circles) shows cathode side.
5. The transistor terminal to which E is affixed shows the emitter.

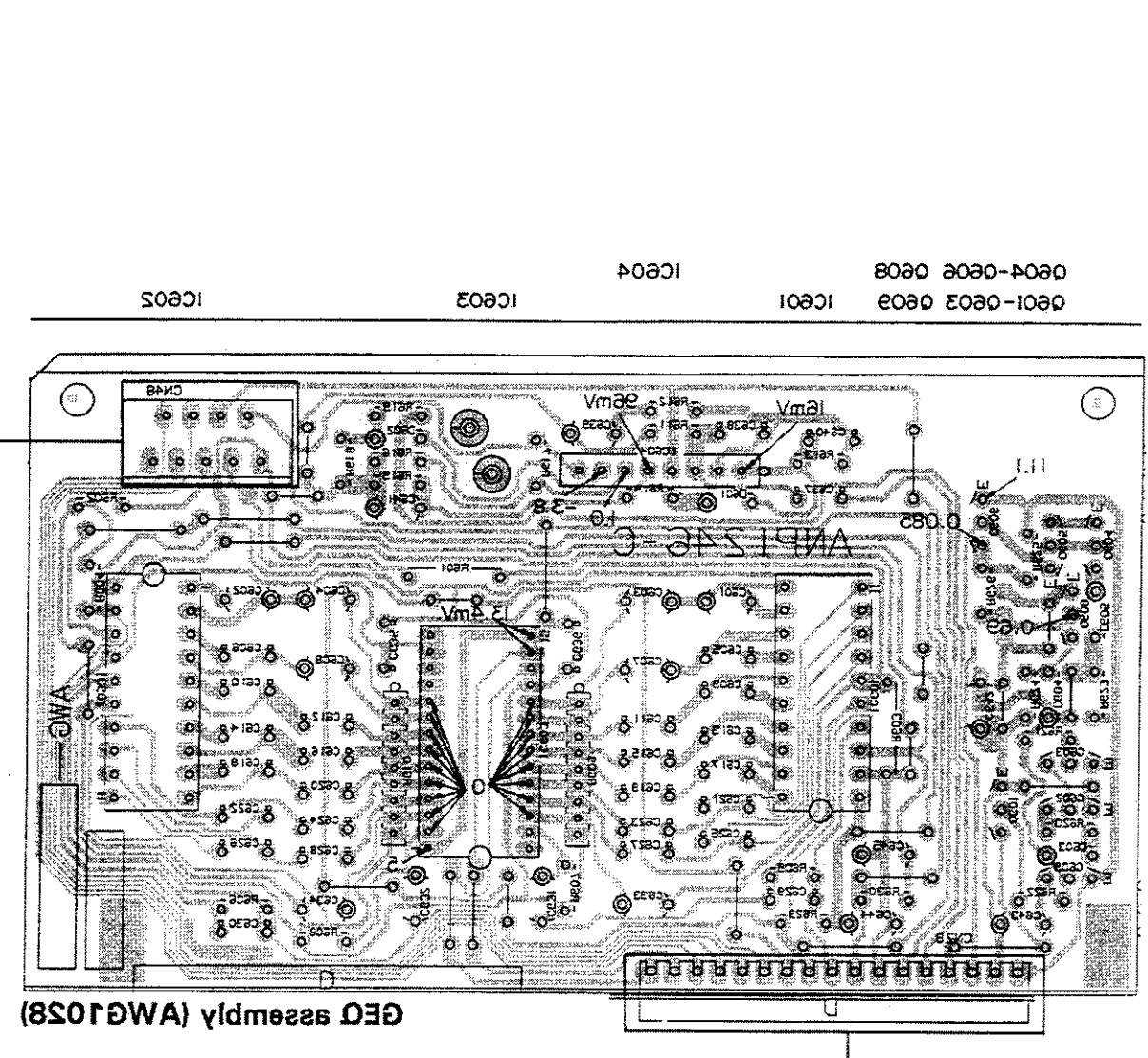
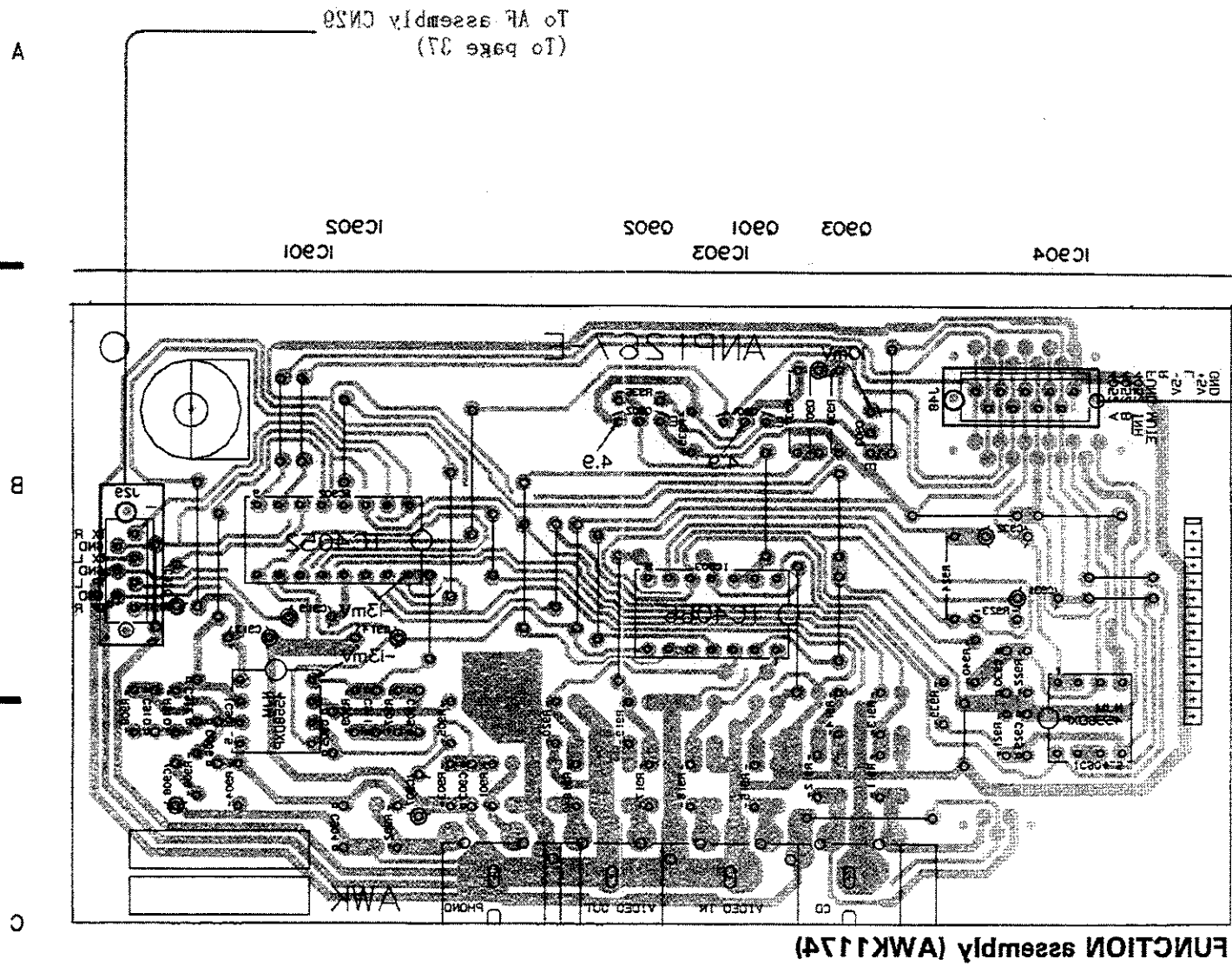

NOTE:
 This picture shows the foil side of the
 printed circuit.

To AF assembly CNS8
 (To page 37)

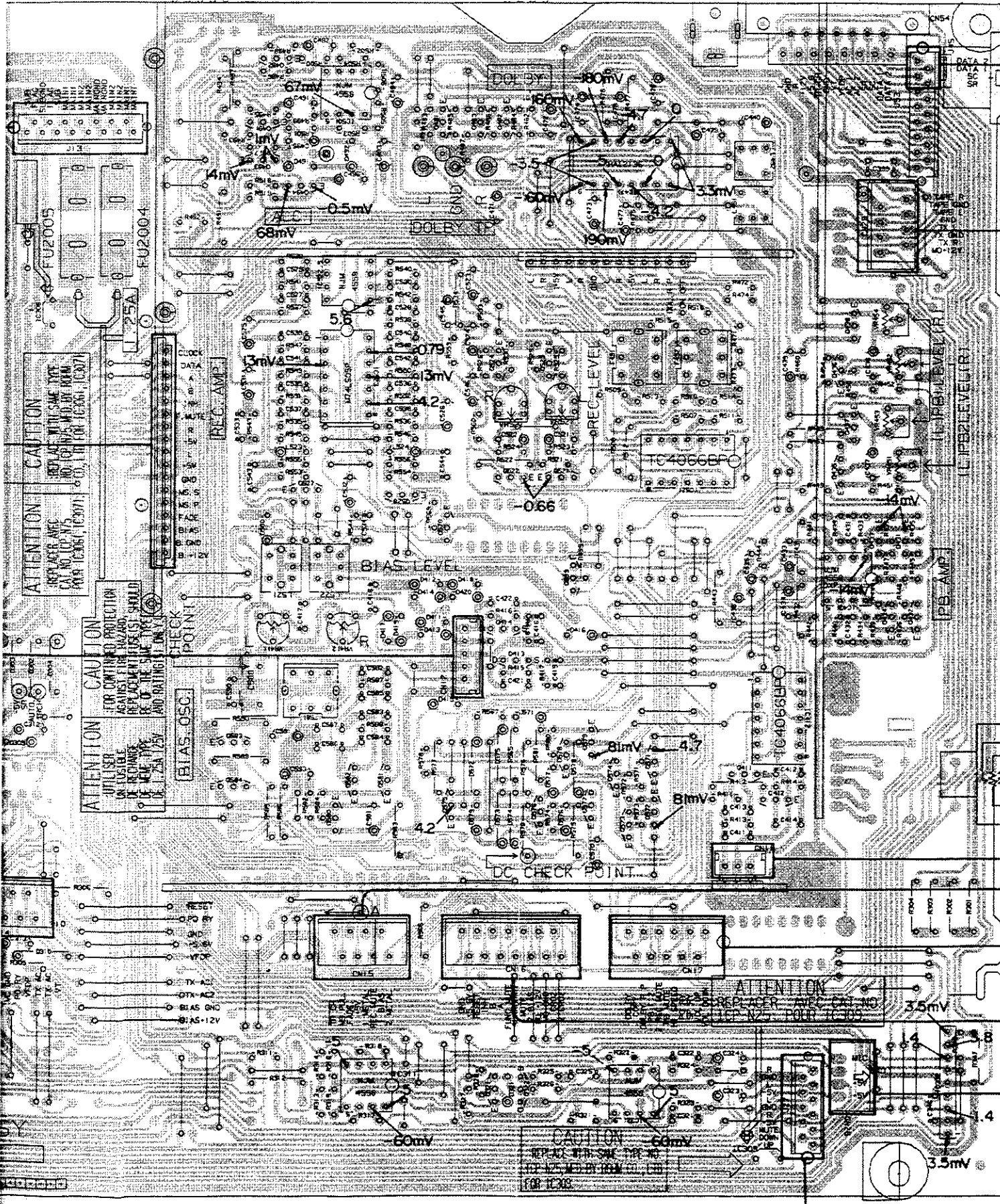

To DECK CTRL assembly CN45
(To page 22)

To FUNCTION assembly J29
(To page 30)

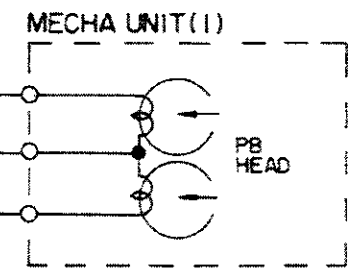
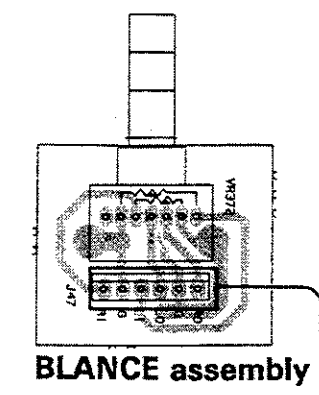

To DECK CTRL assembly J15
(To page 22)

To DECK CTRL assembly J17
(To page 22)

To DECK CTRL assembly J16
(To page 22)

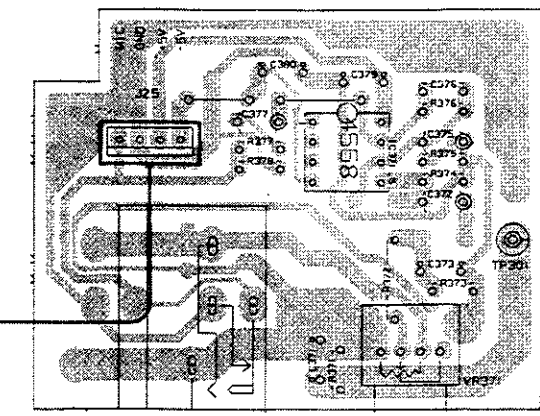

- NOTE
1. This P.C.B connection diagram is viewed from the parts mounted side.
 2. The parts which have been mounted on the board can be replaced with those shown with the corresponding wiring symbols listed in the following Table.

P.C.B. pattern diagram indication	Corresponding part symbol	Part Name
		Transistor
		Radiator type transistor
		Diode
		Resistor
		Capacitor (Polarity)
		Capacitor (Non-polarity)

Others

P.C.B. pattern diagram indication	Part Name
IC	IC
S	Switch
RY	Relay
L	Coil
F	Filter
VR	Variable resistor or Semi-fixed resistor

3. The capacitor terminal marked with ⊙ (double circles) shows negative terminal.
4. The diode terminal marked with ⊙ (double circles) shows cathode side.
5. The transistor terminal to which E is affixed shows the emitter.

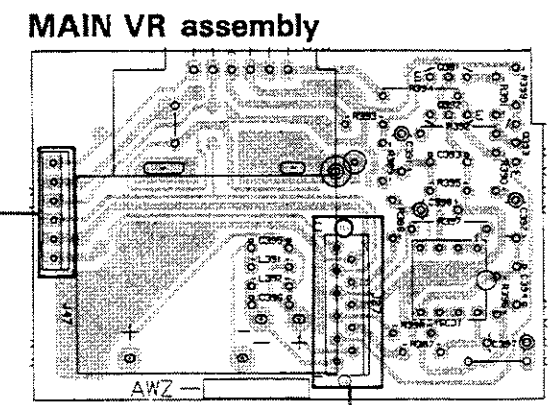

A

B

C

D

A

B

C

D

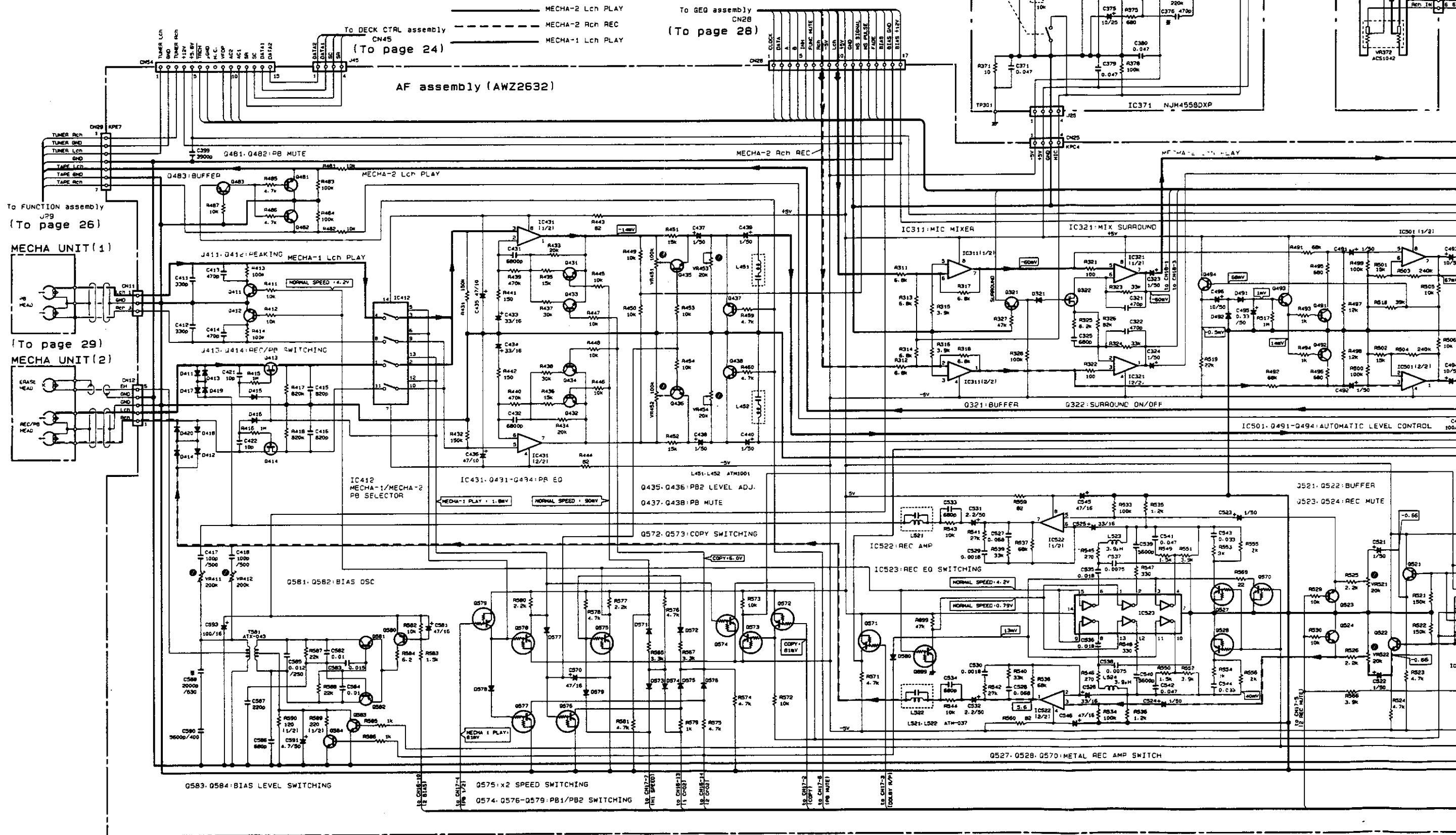

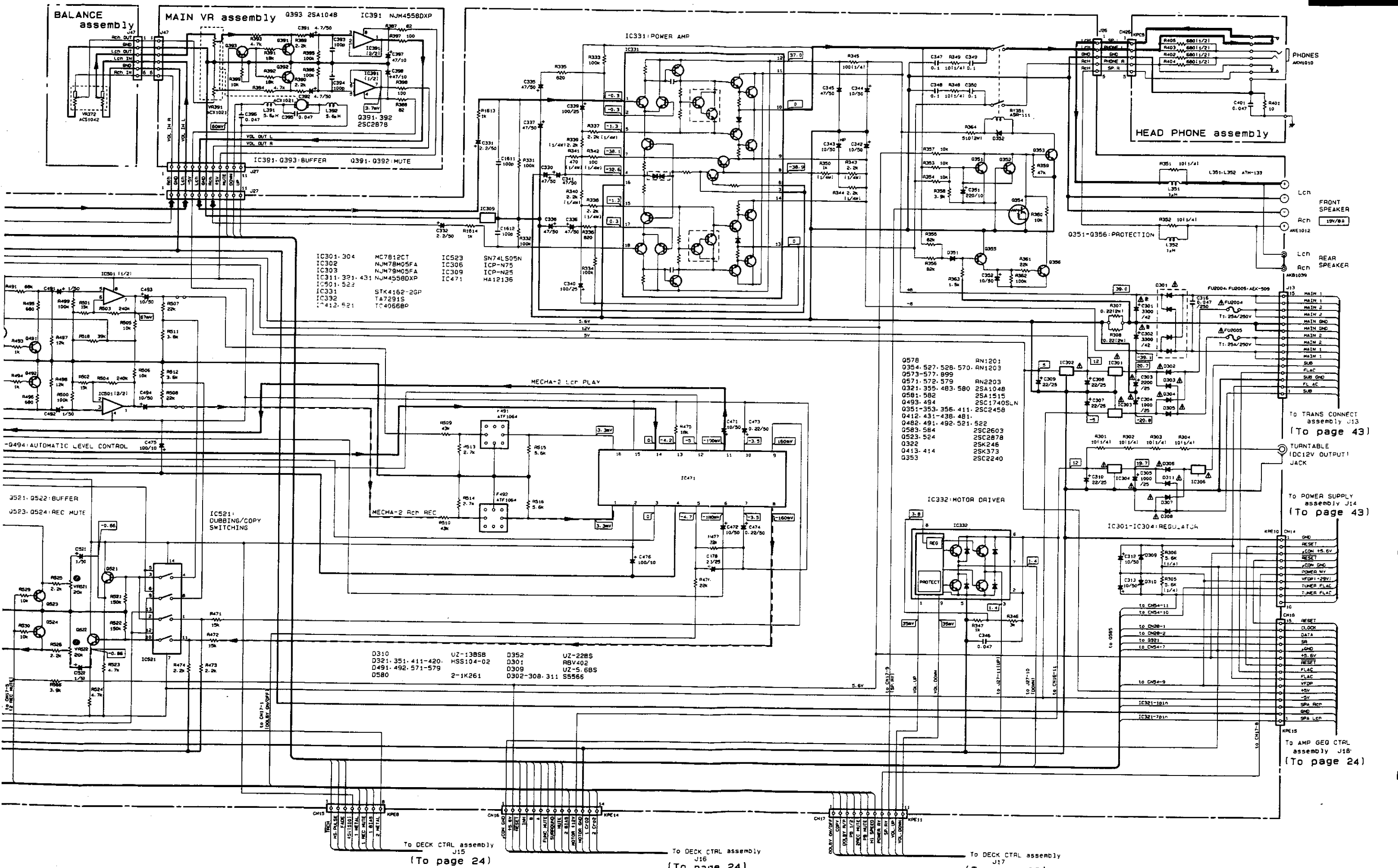

2.5 POWER SUPPLY (AWZ2241), CONNECT and TRANS CONNECT assembly

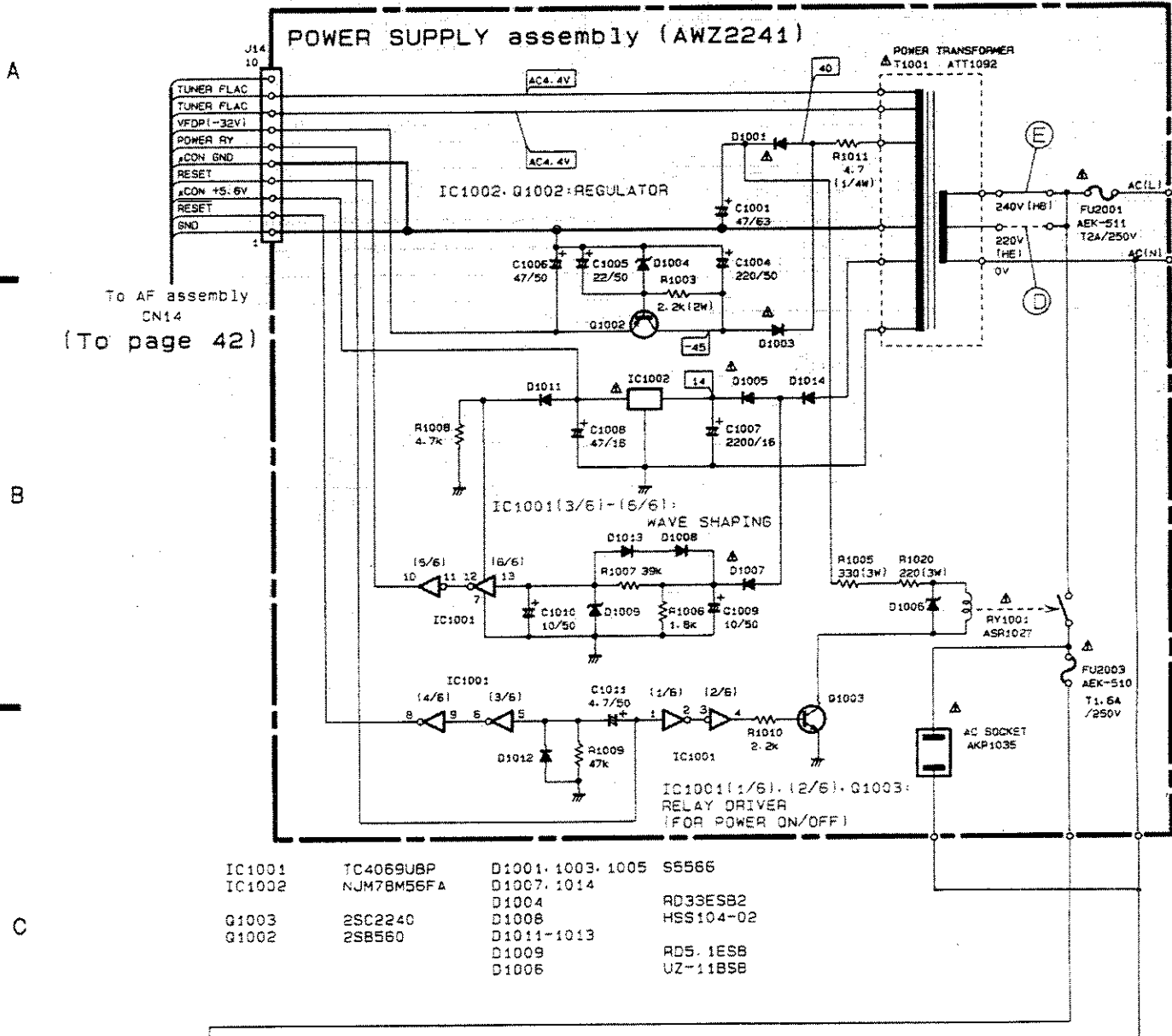

IC1001	TC4069UBP	D1001, 1003, 1005	S5566
IC1002	NJM78M56FA	D1007, 1014	
Q1003	2SC2240	D1004	RD33ESB2
Q1002	2SB560	D1008	HSS104-02
		D1011-1013	
		D1009	RD5.1ESB
		D1006	UZ-11BSB

POWER SUPPLY assembly (AWZ2241)

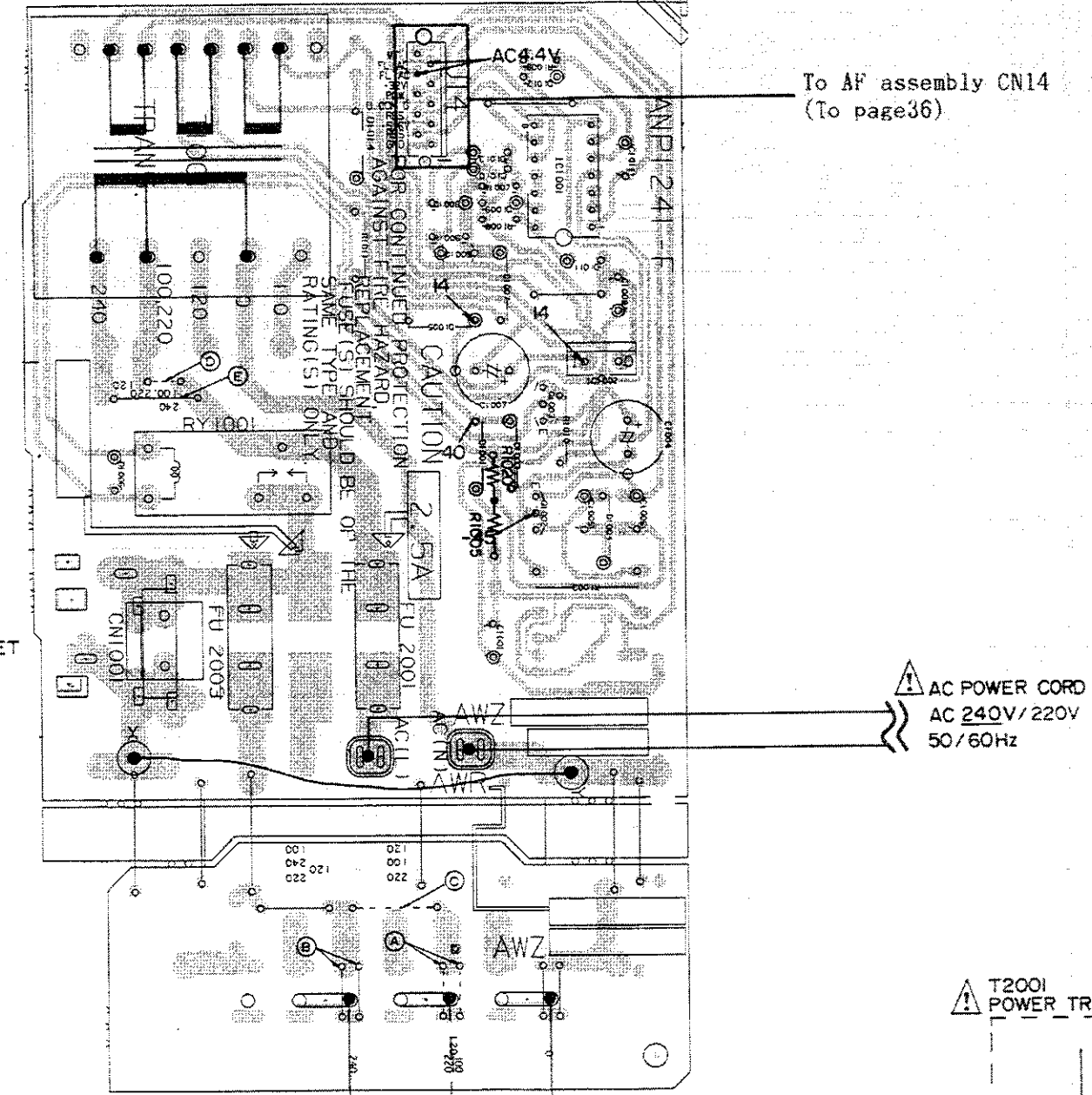

NOTE
1. This P.C.B. connection di...
2. The parts which have b...
with the corresponding v...

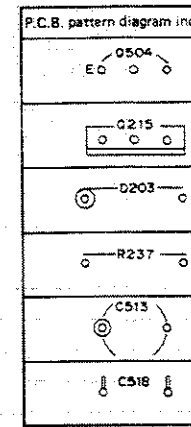

Others
P.C.B. pattern diagram indic...

3. The capacitor terminal m...
4. The diode terminal mar...
5. The transistor terminal

CONNECT assembly TRANS CONNECT assembly

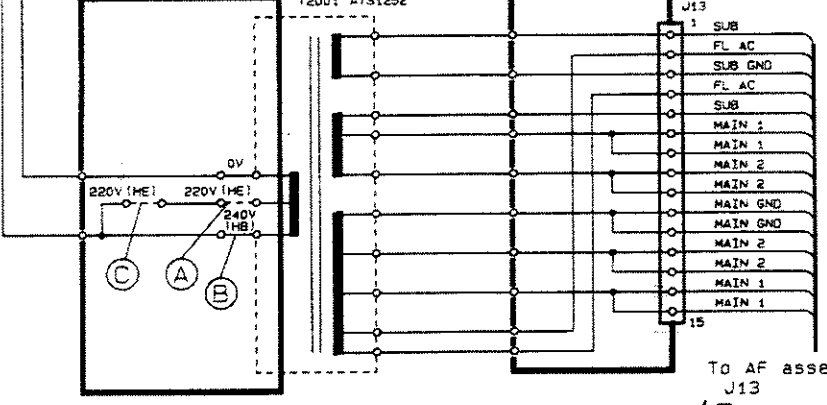

Line Voltage Selection (FOR HE AND HB TYPES)

Line voltage can be changed with the following steps.

1. Disconnect the AC power cord.
2. Remove the top cover.
3. Change the position of the jumper wires (A)-(E) as follows.
4. Stick the line voltage label on the rear panel.

Jumper wires	220V (HE)	240V (HB)
(A)	○	×
(B)	×	○
(C)	○	×
(D)	○	×
(E)	×	○

○: Be needed
×: Be needless

Part No.	Description
AAX-193	220V label
AAX-192	240V label

To AF assembly J13 (To page 36)

NOTE

- 1. This P.C.B connection diagram is viewed from the parts mounted side.
- 2. The parts which have been mounted on the board can be replaced with those shown with the corresponding wiring symbols listed in the following Table.

P.C.B. pattern diagram indication	Corresponding part symbol	Part Name
		Transistor
		Radiator type transistor
		Diode
		Resistor
		Capacitor (Polarity)
		Capacitor (Non-polarity)

Others

P.C.B. pattern diagram indication	Part Name
IC	IC
S	Switch
RY	Relay
L	Coil
F	Filter
VR	Variable resistor or Semi-fixed resistor

- 3. The capacitor terminal marked with ⊕ (double circles) shows negative terminal.
- 4. The diode terminal marked with ⊕ (double circles) shows cathode side.
- 5. The transistor terminal to which E is affixed shows the emitter.

CN14

POWER CORD
220V/220V
Hz

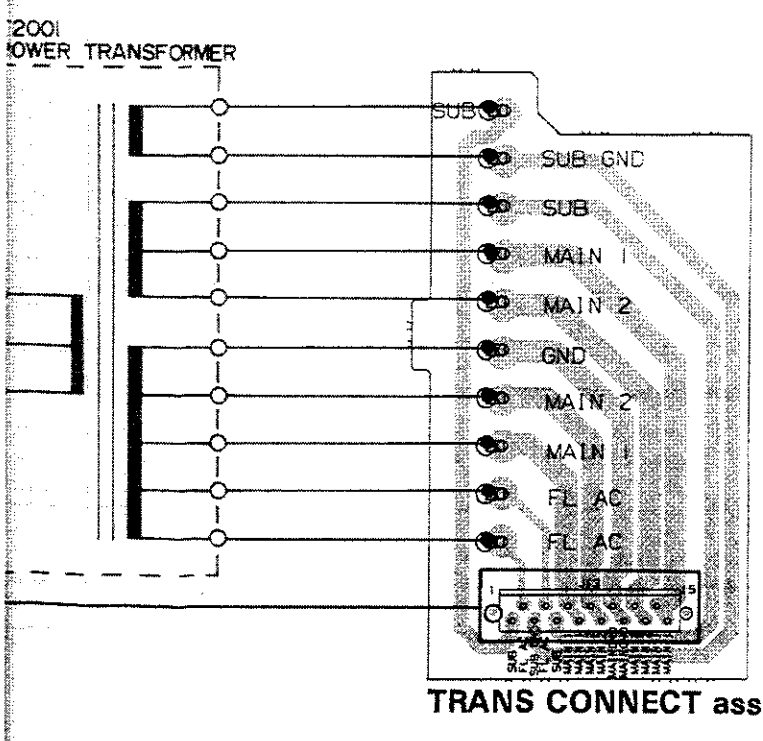

NOTE:

This picture shows the foil side of the printed circuit.

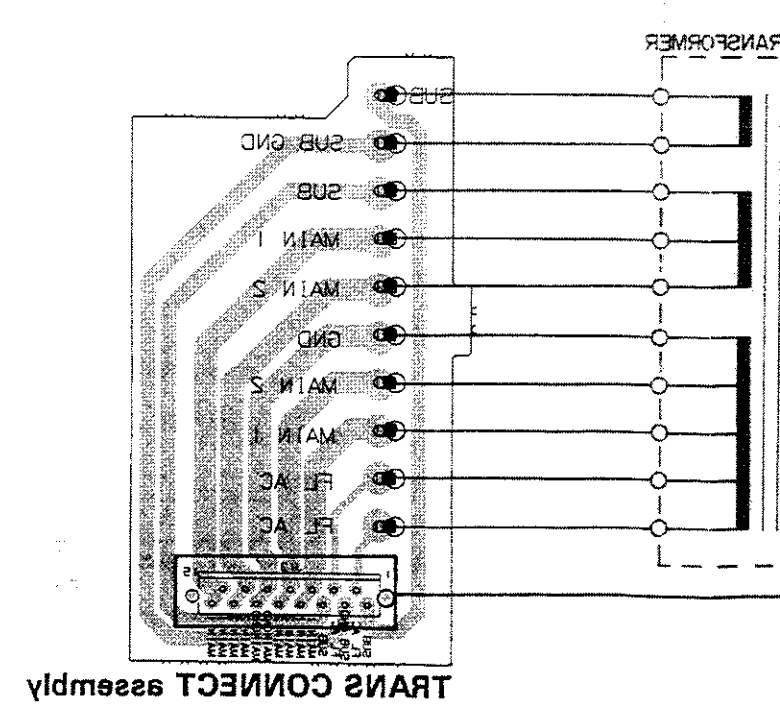

To AF assembly CN14
(To page 36)

AC POWER CORD
220V/220V
50/60Hz

To AF assembly J13
(To page 36)

POWER SUPPLY assembly (AW22541)

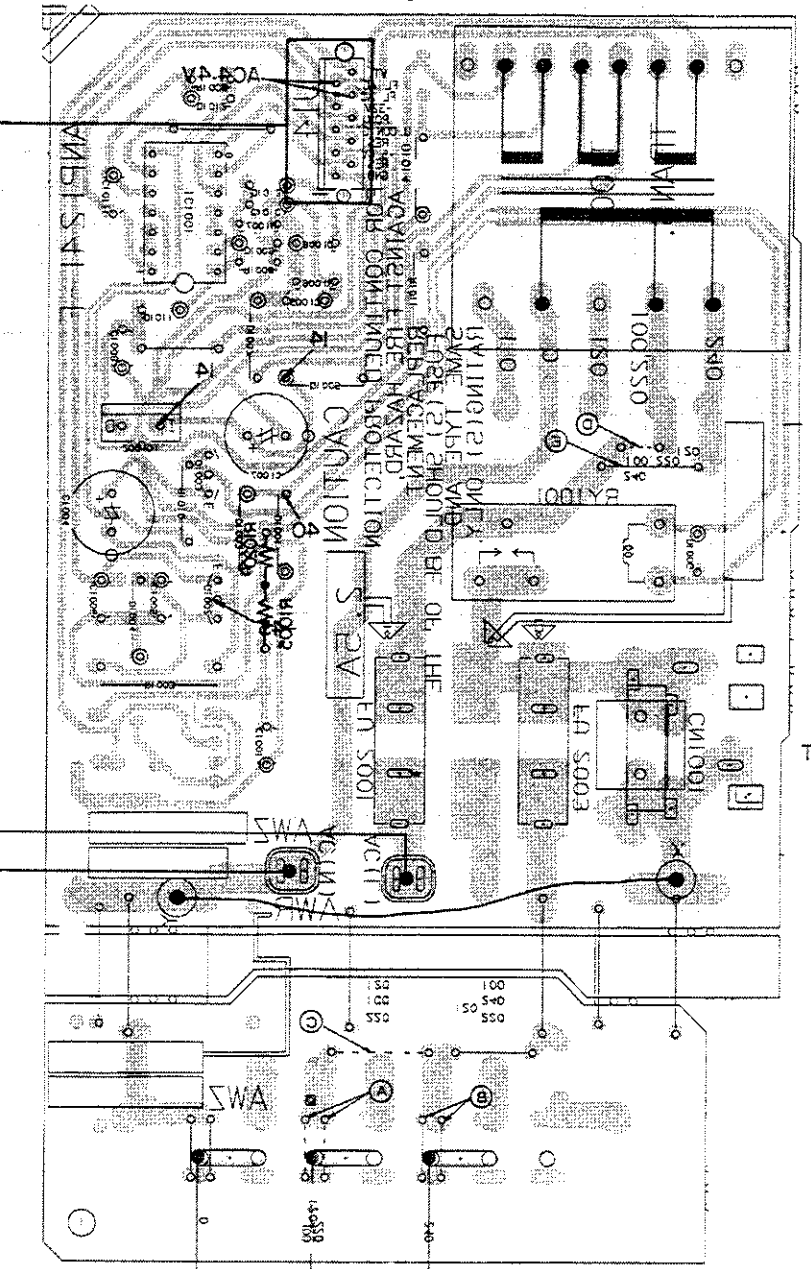

CONNECT assembly

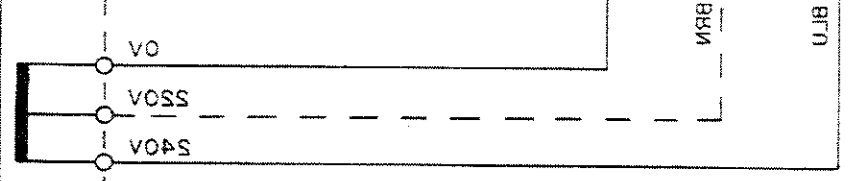

3. P.C.B's PARTS LIST

NOTES:

- Parts without part number cannot be supplied.
- Parts marked by "⊙" are not always kept in stock. Their delivery time may be longer than usual or they may be unavailable.
- The Δ mark found on some component parts indicates the importance of the safety factor of the part. Therefore, when replacing, be sure to use parts of identical designation.
- When ordering resistors, first convert resistance values into code form as shown in the following examples.

Ex. 1 When there are 2 effective digits (any digit apart from 0), such as 560 ohm and 47k ohm (tolerance is shown by J = 5%, and K = 10%).

560 Ω	56 $\times 10^1$	561.....	RD1/4PS	\square	\square	\square	J
47k Ω	47 $\times 10^3$	473.....	RD1/4PS	\square	\square	\square	J
0.5 Ω	0R5.....		RN2H	\square	\square	\square	K
1 Ω	010.....		RS1P	\square	\square	\square	K

Ex. 2 When there are 3 effective digits (such as in high precision metal film resistors).

5.62k Ω	562 $\times 10^1$	5621.....	RN1/4SR	\square	\square	\square	F
----------------	-------------------	-----------	---------	-----------	-----------	-----------	---

Mark	No.	Description	Parts No.	Mark	No.	Description	Parts No.
SPEANA ASSEMBLY (AWG1025)							
SEMICONDUCTORS							
	IC721-725	OP-AMP IC	NJM4558DXP	Q601		TRANSISTOR	RN1201
	IC726	LOGIC IC	TC4051BP	Q602		TRANSISTOR	2SC2458
	Q721-729	TRANSISTOR	RN1201	Q603		TRANSISTOR	RN2204
	Q730	TRANSISTOR	2SA1048	Q604,605		TRANSISTOR	2SC2603
	Q731-733	TRANSISTOR	2SC2458	Q606		TRANSISTOR	2SA1115
	D721-728	DIODE	HSS104-02	Q608		TRANSISTOR	2SC2458
CAPACITORS				Q609		TRANSISTOR	RN2203
	C721,722	CERAMIC CAPACITOR	CKDYX823M16	D601,602		DIODE	HSS104-02
	C723,724	CERAMIC CAPACITOR	CKCYX333M16	D603		ZENER DIODE	HZS5ALL
	C725,726	CERAMIC CAPACITOR	CKCYX123M16	D604		ZENER DIODE	HZS7B2L
	C727,728	CERAMIC CAPACITOR	CKCYB472K50	D605		DIODE	HSS104-02
	C729,730	CERAMIC CAPACITOR	CKCYB182K50	CAPACITORS			
	C731,732	CERAMIC CAPACITOR	CKCYB821K50	C601,602		ELECTR.CAPACITOR	CEASR15M50
	C733,734	CERAMIC CAPACITOR	CKCYB331K50	C603,604		ELECTR.CAPACITOR	CEASR47M50
	C735-741	CERAMIC CAPACITOR	CKDYF473Z50	C605,606		CERAMIC CAPACITOR	CKDYX683M16
RESISTORS				C607,608		ELECTR.CAPACITOR	CEASR15M50
	All resistors		RD1/8PM	C609,610		CERAMIC CAPACITOR	CKDYX273M16
OTHERS				C611,612		CERAMIC CAPACITOR	CKDYX683M16
	CN30	JUMPER CONNECTOR	KPE13	C613,614		CERAMIC CAPACITOR	CGMYX103M16
		13-P		C615,616		CERAMIC CAPACITOR	CKDYX273M16
GEQ ASSEMBLY (AWG1028)				C617,618		CERAMIC CAPACITOR	CGMYX472M25
This GEQ ASSEMBLY (AWG1028) is a part of				C619,620		CERAMIC CAPACITOR	CGMYX103M16
AF ASSEMBLY (AWZ2632)				C621,622		CERAMIC CAPACITOR	CGMYB182M50
SEMICONDUCTORS				C623,624		CERAMIC CAPACITOR	CGMYX472M25
	IC601,602	GEQ IC	LA3607	C625,626		CERAMIC CAPACITOR	CKMYB681K50
	IC603	GEQ EVR IC	LC7522	C627,628		CERAMIC CAPACITOR	CGMYB182M50
	IC604	OP-AMP IC	M5218L	C629,630		CERAMIC CAPACITOR	CKCYB331K50
				C631-634		ELECTR.CAPACITOR	CEAS2R2M50
				C635-637		CERAMIC CAPACITOR	CKDYX473M16
				C638		CERAMIC CAPACITOR	CCCSL101J50
				C639		ELECTR.CAPACITOR	CEAS010M50
				C640		CERAMIC CAPACITOR	CCCSL560J50

Mark	No.	Description	Parts No.
	C641	ELECTR.CAPACITOR	CEAS0R1M50
	C642	ELECTR.CAPACITOR	CEAS331M16
	C643	ELECTR.CAPACITOR	CEAS100M25
	C644,645	ELECTR.CAPACITOR	CEAS101M10

RESISTORS

	R609,610	RESISTOR ARRAY (1MΩ) Other resistors	RA8T105J RD1/8PM□□□□
--	----------	--	-------------------------

OTHERS

	CN48	JUMPER CONNECTOR 9-P	KPE9
--	------	-------------------------	------

FUNCTION ASSEMBLY (AWK1174)

SEMICONDUCTORS

	IC901	OP-AMP IC	NJM4558DXP
	IC902	LOGIC IC	TC4052BP
	IC903	LOGIC IC	TC4066BP
	IC904	OP-AMP IC	NJM4558DXP
	Q901,903	TRANSISTOR	DTA143ES
	Q902		DTC143ES
	D901	DIODE	HSS104-02

CAPACITORS

	C903-906	CERAMIC CAPACITOR	CCCSL101J50
	C907,908	ELECTR.CAPACITOR	CEAS2R2M50
	C909,910	CERAMIC CAPACITOR	CKCYB152K50
	C911,912	CERAMIC CAPACITOR	CKCYB562K50
	C913,914	ELECTR.CAPACITOR	CEAS470M10
	C919,920	ELECTR.CAPACITOR	CEAS100M25
	C929,930	CERAMIC CAPACITOR	CCCSL101J50
	C931,932	ELECTR.CAPACITOR	CEAS100M25

RESISTORS

	All resistors	RD1/8PM□□□□
--	---------------	-------------

OTHERS

	PHONO JACK 4-P	AKB1009
	PHONO JACK 4-P	AKB1085

AF ASSEMBLY (AWZ2632)

SEMICONDUCTORS

	IC301	REGULATOR IC	MC7812CT
	IC302	REGULATOR IC	NJM78M05FA
	IC303	REGULATOR IC	NJM79M05FA
	IC304	REGULATOR IC	MC7812CT
	IC306	IC PROTECTOR	ICP-N75
	IC309	IC PROTECTOR	ICP-N25
	IC311	OP-AMP IC	NJM4558DXP
	IC321	OP-AMP IC	NJM4558DXP

Mark	No.	Description	Parts No.
	IC331	AUDIO IC	STK4162-2GP
	IC332	MECHANISM DRIVER IC	TA7291S

	IC412	LOGIC IC	TC4066BP
	IC431	OP-AMP IC	NJM4588DXP
	IC471	DOLBY-B IC	HA12136
	IC501	OP-AMP IC	NJM4558DXP
	IC521	LOGIC IC	TC4066BP

	IC522	OP-AMP IC	NJM4558DXP
	IC523	LOGIC IC	SN74LS05N

	Q321	TRANSISTOR	2SA1048
	Q322	N-FET	2SK246
	Q351-353	TRANSISTOR	2SC2458

	Q354	TRANSISTOR	RN1203
	Q355	TRANSISTOR	2SA1048
	Q356	TRANSISTOR	2SC2458
	Q411,412	TRANSISTOR	2SC2458
	Q413,414	N-FET	2SK373

	Q431-438	TRANSISTOR	2SC2458
	Q481,482	TRANSISTOR	2SC2458
	Q483	TRANSISTOR	2SA1048
	Q491,492	TRANSISTOR	2SC2458
	Q493,494	TRANSISTOR	2SC1740SLN

	Q521,522	TRANSISTOR	2SC2458
	Q523,524	TRANSISTOR	2SC2878
	Q527,528	TRANSISTOR	RN1203
	Q570	TRANSISTOR	RN1203
	Q571,572	TRANSISTOR	RN2203

	Q573-577	TRANSISTOR	RN1203
	Q578	TRANSISTOR	RN1201
	Q579	TRANSISTOR	RN2203
	Q580	TRANSISTOR	2SA1048
	Q581,582	TRANSISTOR	2SA1515

	Q583,584	TRANSISTOR	2SC2603
	Q899		RN1203

	D301	DIODE	RBV402
	D302-308	DIODE	S5566
	D309	ZENER DIODE	UZ-5.6BS
	D310	ZENER DIODE	UZ-13BSB

	D311	DIODE	S5566
--	------	-------	-------

	D321	DIODE	HSS104-02
	D351	DIODE	HSS104-02
	D352	ZENER DIODE	UZ-22BS
	D411-420	DIODE	HSS104-02

	D491,492	DIODE	HSS104-02
	D571-579	DIODE	HSS104-02
	D580	DIODE	2-1K261

Mark No.	Description	Parts No.	Mark No.	Description	Parts No.
RELAY			C437,438	ELECTR.CAPACITOR	CEAS010M50
RY351	RELAY	ASR-111	C439,440	ELECTR.CAPACITOR	CEAS010M50
COILS & TRANSFORMER			C471,472	ELECTR.CAPACITOR	CEAS100M50
L351,352	COIL	ATH-133	C473,474	ELECTR.CAPACITOR	CEASR22M50
L451,452	COIL	ATM1001	C475,476	ELECTR.CAPACITOR	CEAS101M10
L521,522	COIL	ATM-037	C478	ELECTR.CAPACITOR	CEAS220M25
L523,524	INDUCTOR	LTA392J	C491,492	ELECTR.CAPACITOR	CEAS010M50
T581	OSC TRANSFORMER	ATX-043	C493,494	ELECTR.CAPACITOR	CEAS100M50
FILTERS			C495	ELECTR.CAPACITOR	CEASR33M50
F491,F492	DOLBY FILTER	ATF1064	C496	ELECTR.CAPACITOR	CEAS100M50
CAPACITORS			C521-524	ELECTR.CAPACITOR	CEAS010M50
C1611,1612	CERAMIC CAPACITOR	CCCSL101J50	C525,526	ELECTR.CAPACITOR	CEAS330M16
C301,302	ELECTR.CAPACITOR (3300 μ F/42V)	ACH1017	C527,528	AUDIO FILM CAPACITOR	CFTXA683J50
C303	ELECTR.CAPACITOR	CEAS222M25	C529,530	CERAMIC CAPACITOR	CKCYB182K50
C304,305	ELECTR.CAPACITOR	CEAS102M25	C531,532	ELECTR.CAPACITOR	CEAS2R2M50
C307-310	ELECTR.CAPACITOR	CEAS220M25	C533,534	CERAMIC CAPACITOR	CKMYB681K50
C312,313	ELECTR.CAPACITOR	CEAS100M50	C535,536	MYLOR FILM CAPACITOR	CQMA183J50
C316	MYLOR FILM CAPACITOR	CQMA473K250	C537,538	MYLOR FILM CAPACITOR	CQMA752J50
C321,322	PL STYRENE CAPACITOR	CQSA471J50	C539,540	CERAMIC CAPACITOR	CKCYB562K50
C323,324	ELECTR.CAPACITOR	CEAS010M50	C541,542	MYLOR FILM CAPACITOR	CQMA473J50
C325	CERAMIC CAPACITOR	CKMYB681K50	C543,544	MYLOR FILM CAPACITOR	CQMA333J50
C330	ELECTR.CAPACITOR	CEAS470M50	C545,546	ELECTR.CAPACITOR	CEAS470M16
C331	ELECTR.CAPACITOR	CEAS2R2M50	C570	ELECTR.CAPACITOR	CEAS470M16
C332	ELECTR.CAPACITOR	CEHAQ2R2M50	C581	ELECTR.CAPACITOR	CEAS470M16
C335	ELECTR.CAPACITOR	CEAS470M50	C582	CERAMIC CAPACITOR	CKCYB103K50
C336	ELECTR.CAPACITOR	CEHAQ470M50	C583	MYLOR FILM CAPACITOR	CQMA153K50
C337,338	ELECTR.CAPACITOR	CEAS470M50	C584	CERAMIC CAPACITOR	CKCYB103K50
C339,340	ELECTR.CAPACITOR	CEAS101M25	C585	MYLOR FILM CAPACITOR	CQMA123K250
C341	ELECTR.CAPACITOR	CEAS470M50	C586	CERAMIC CAPACITOR	CKMYB681K50
C342	ELECTR.CAPACITOR	CEAS100M50	C587	CERAMIC CAPACITOR	CKMYB221K50
C343	ELECTR.CAPACITOR	CEANP100M50	C588	CQPA(2000P/630V)	ACE1020
C344	ELECTR.CAPACITOR	CEAS100M50	C590	MYLOR FILM CAPACITOR	CQMA562K400
C345	ELECTR.CAPACITOR	CEANP470M50	C591	ELECTR.CAPACITOR	CEAS4R7M50
C346	CERAMIC CAPACITOR	CKDYF473Z50	C593	ELECTR.CAPACITOR	CEAS101M16
C347-350	MYLOR FILM CAPACITOR	CQMA104K50	RESISTORS		
C351	ELECTR.CAPACITOR	CEAS221M10	VR411,412	VR (200k Ω)	VRTM6V204
C352	ELECTR.CAPACITOR	CEAS100M50	VR451,452	VR (100k Ω)	VRTM6H104
C399	CERAMIC CAPACITOR	CKDYB392K50	VR453,454	VR (20k Ω)	VRTM6H203
C411,412	CERAMIC CAPACITOR	CKMYB331K50	VR521,522	VR (22k Ω)	ACP1026
C413,414	CERAMIC CAPACITOR	CKMYB471K50	R301-304	CARBON FILM RESISTOR	RD1/4PM100J
C415,416	CERAMIC CAPACITOR	CKMYB821K50	R305,306	CARBON FILM RESISTOR	RD1/4PM562J
C417,418	CERAMIC CAPACITOR	CCCSL101K500	R307,308	METAL OXIDE RESISTOR	RS2LMFR22J
C421,422	CERAMIC CAPACITOR	CCMSL100D50	R337-340	CARBON FILM RESISTOR	RD1/4PM222J
C431,432	MYLOR FILM CAPACITOR	CQMA682J50			
C433,434	ELECTR.CAPACITOR	CEAS330M16			
C435,436	ELECTR.CAPACITOR	CEAS470M10			

Mark	No.	Description	Parts No.
R341		FUSLIBLE RESISTOR	RFA1/4PL471J
R342		CARBON FILM RESISTOR	RD1/4PMFL101J
R343,344		CARBON FILM RESISTOR	RD1/4PM222J
R345		CARBON FILM RESISTOR	RD1/4PMFL101J
R348,349		CARBON FILM RESISTOR	RD1/4PMF100J
R350		CARBON FILM RESISTOR	RD1/4PMFL102J
R351,352		CARBON FILM RESISTOR	RD1/4PMFL100J
R364		METAL OXIDE RESISTOR	RS2LMF511J
R589,590		CARBON FILM RESISTOR Other resistors	RD1/2PM□□□J RD1/8PM□□□J

OTHERS

CN14		JUMPER CONNECTOR 10-P	KPE10
CN15		JUMPER CONNECTOR 8-P	KPE8
CN16		JUMPER CONNECTOR 14-P	KPE14
CN17		JUMPER CONNECTOR 11-P	KPE11
CN18		JUMPER CONNECTOR 15-P	KPE15
CN25		JUMPER CONNECTOR 4-P	KPC4
CN29		JUMPER CONNECTOR 7-P	KPE7
		PIN JACK 2-P (SPEAKER)	AKB1039
		TERMINAL 4-P (SPEAKER)	AKE1012
		JACK (PL DC+12V) Socket 15-P (To TUNER)	AKN-203 AKP1038
		GEQ ASSEMBLY (As to the parts list, refer to page47)	AWG1028

MAIN VR ASSEMBLY

SEMICONDUCTORS

IC391		OP-AMP IC	NJM4558DXP
Q391,392		TRANSISTOR	2SC2878
Q393		TRANSISTOR	2SA1048

COILS

L391,392		AXIAL INDUCTOR (5.6μH)	LAU5R6K
----------	--	------------------------	---------

Mark	No.	Description	Parts No.
CAPACITORS			
	C391,392	ELECTR.CAPACITOR	CEAS4R7M50
	C393,394	CERAMIC CAPACITOR	CCMSL101J50
	C395,396	CERAMIC CAPACITOR	CKCYF473Z50
	C397,398	ELECTR.CAPACITOR	CEAS470M10

RESISTORS

VR391		VR (100k) Other resistors	ACX1021 RD1/8PM□□□J
-------	--	------------------------------	------------------------

HEAD PHONE ASSEMBLY

CAPACITOR

C401		CERAMIC CAPACITOR	CKCYF473Z50
------	--	-------------------	-------------

RESISTORS

R401		CARBON FILM RESISTOR	RD1/8PM100J
R402-405		CARBON FILM RESISTOR	RD1/2PMF681J

OTHERS

CN26		JUMPER CONNECTOR 5-P JACK (HEADPHONE)	KPC5 AKN1010
------	--	--	-----------------

TRANSE CONNECT ASSEMBLY

No Parte are supplied with the TRANS CONNECT assembly

BALANCE ASSEMBLY

RESISTOR

VR372		VR(10k)	ACS1042
-------	--	---------	---------

MIC ASSEMBLY

SEMICONDUCTOR

IC371		OP-AMP IC	NJM4558DXP
-------	--	-----------	------------

CAPACITORS

C371		CERAMIC CAPACITOR	CKCYF473Z50
C372		ELECTR.CAPACITOR	CEAS010M50
C373		CERAMIC CAPACITOR	CKMYB631K50
C375		ELECTR.CAPACITOR	CEAS100M25
C376		CERAMIC CAPACITOR (470p)	ACG1019
C377		ELECTR.CAPACITOR	CEAS100M25
C379,380		CERAMIC CAPACITOR	CKCYF473Z50

RESISTORS

VR371		VR (10K-X1) Other resistors	ACS1043 RD1/8PM□□□J
-------	--	--------------------------------	------------------------

Mark No.	Description	Parts No.	Mark No.	Description	Parts No.
OTHERS			COIL		
	JACK (MIC)	AKN1017	L801	AXIAL INDUCTOR (22 μ H)	LAU220K
DECK-1 SW ASSEMBLY			CAPACITORS		
SWITCHES			C801	ELECTR.CAPACITOR	CEASR33M50
S811-815	SWITCH	ASG1034	C802	ELECTR.CAPACITOR	CEAS101M16
DECK-2 SW ASSEMBLY			C803	ELECTR.CAPACITOR	CEAS101M10
SWITCHES			C804-807	CERAMIC CAPACITOR	CKDYF473Z50
S821-825	SWITCH	ASG1034	C839,840	CERAMIC CAPACITOR	CKDYB102K50
DECK CENTER ASSEMBLY			RESISTORS		
SEMICONDUCTORS			VR801,802	VR	VRTM6H203
Q822-825	TRANSISTOR	2SA1048	VR803	VR	VRTM6H103
D841-844	LED	AEL1084	Other resistors		
D854	DIODE	HSS104-02	OTHERS		
D856-858	DIODE	HSS104-02	X801	(4.19MHz)	ASS1018
D861	LED	AEL1091	CN21	JUMPER CONNECTOR	KPE11
D862,863	LED(RED)	AEL1065	11-P		
SWITCHES			CN22	JUMPER CONNECTOR	KPE14
S848,849	SWITCH	ASH1014	14-P		
S853	SWITCH	ASG1034	CN45	JUMPER CONNECTOR	KPE4
S857	SWITCH	ASG1034	4-P		
S862	SWITCH	ASG1034	AMP, GEQ CTRL ASSEMBLY (AWZ2642)		
S871,872	SWITCH	ASG1034	SEMICONDUCTORS		
S874,875	SWITCH	ASG1034	IC771		PD3161
RESISTORS			IC701,702		SN74LS05N
	All resistors	RD1/8PM□□□□	IC703	LOGIC IC	TC4081BP
DECK CTRL ASSEMBLY(AWZ2641)			IC727	OP-AMP IC	NJM4558DXP
SEMICONDUCTORS			Q701,702	TRANSISTOR	RN2201
IC801	DECK AMP	PDE029-C	D707	LED(RED)	AEL1099
IC802	LOGIC IC	SN74LS42N	D711	LED(RED)	AEL1099
Q801,802	TRANSISTOR	RN2204	D715	LED(RED)	AEL1099
Q803-806	TRANSISTOR	RN1201	D718	LED(RED)	AEL1099
Q807-812	TRANSISTOR	2SA1515	D719	LED	AEL1105
Q814,815	TRANSISTOR	RN1201	D721	LED	AEL1081
D801,802	DIODE	HSS104-02	D722	LED(RED)	AEL1099
D808	DIODE	HSS104-02	D731	LED(RED)	AEL1099
D810-815	DIODE	HSS104-02	D771-780	DIODE	HSS104-02
D817	DIODE	HSS104-02	D782	DIODE	HSS104-02
D820-826	DIODE	HSS104-02	D785,786	DIODE	HSS104-02
D835-840	DIODE	HSS104-02	SWITCHES		
			S707	SWITCH	ASG1034
			S709	SWITCH	ASG1034
			S715	SWITCH	ASG1034
			S718-722	SWITCH	ASG1034
			S771-793	SWITCH	ASG1034
			COIL		
			L771	AXIAL INDUCTOR (22 μ H)	LAU220K

Mark No.	Description	Parts No.
CAPACITORS		
C771,772	CERAMIC CAPACITOR	CKDYF473Z50
C773	(47000 μ / 5.5 V)	ACH1135
C774	CERAMIC CAPACITOR	CKDYF473Z50
C775	CERAMIC CAPACITOR	CKCYB102K50
C776	CERAMIC CAPACITOR	CKDYF473Z50
C777	ELECTR.CAPACITOR	CEAS100M50
RESISTORS		
R899	CARBON FILM RESISTOR	RD1/2PM1R8J
	Other resistors	RD1/8PM□□□J
OTHERS		
V771	FL TUBE	AAV1071
V772	FL TUBE	AAV1069
X771	(4.19MHz)	ASS1018

Mark No.	Description	Parts No.
RESISTORS		
R1003	METAL OXIDE RESISTOR	RS2LMF222J
R1005	METAL OXIDE RESISTOR	RS3PMF331J
R1020		RS3PMF221J
R1011	CARBON FILM RESISTOR	RD1/4PMFLAR7J
	Other resistors	RD1/8PM□□□J
OTHERS		
△	AC SOCKET 1-P (OUTLET)	AKP1035

CONNECT ASSEMBLY

No parts are supplied with the CONNECT assembly.

POWER SUPPLY ASSEMBLY (AWZ2241)

SEMICONDUCTORS

IC1001	LOGIC IC	TC4069UBP
IC1002	REGULATOR	NJM78M56FA
Q1002	TRANSISTOR	2SB560
Q1003	TRANSISTOR	2SC2240
D1001	DIODE	S5566
D1003	DIODE	S5566
D1004	ZENER DIODE	RD33ESB2
D1005	DIODE	S5566
D1006	ZENER DIODE	UZ-11BSB
D1007	DIODE	S5566
D1008	DIODE	HSS104-02
D1009	ZENER DIODE	RD5.1ESB
D1011-1013	DIODE	HSS104-02
D1014	DIODE	S5566

RELAY

△	RY1001	RELAY	ASR1027
---	--------	-------	---------

TRANSFORMER

T1001	POWER TRANSFORMER	ATT1092
-------	-------------------	---------

CAPACITORS

C1001	ELECTR.CAPACITOR	CEAS470M63
C1004	ELECTR.CAPACITOR	CEAS221M50
C1005	ELECTR.CAPACITOR	CEHAQ220M50
C1006	ELECTR.CAPACITOR	CEAS470M50
C1007	ELECTR.CAPACITOR	CEAS222M16
C1008	ELECTR.CAPACITOR	CEAS470M16
C1009,1010	ELECTR.CAPACITOR	CEAS100M50
C1011	ELECTR.CAPACITOR	CEAS4R7M50

4. ADJUSTMENTS

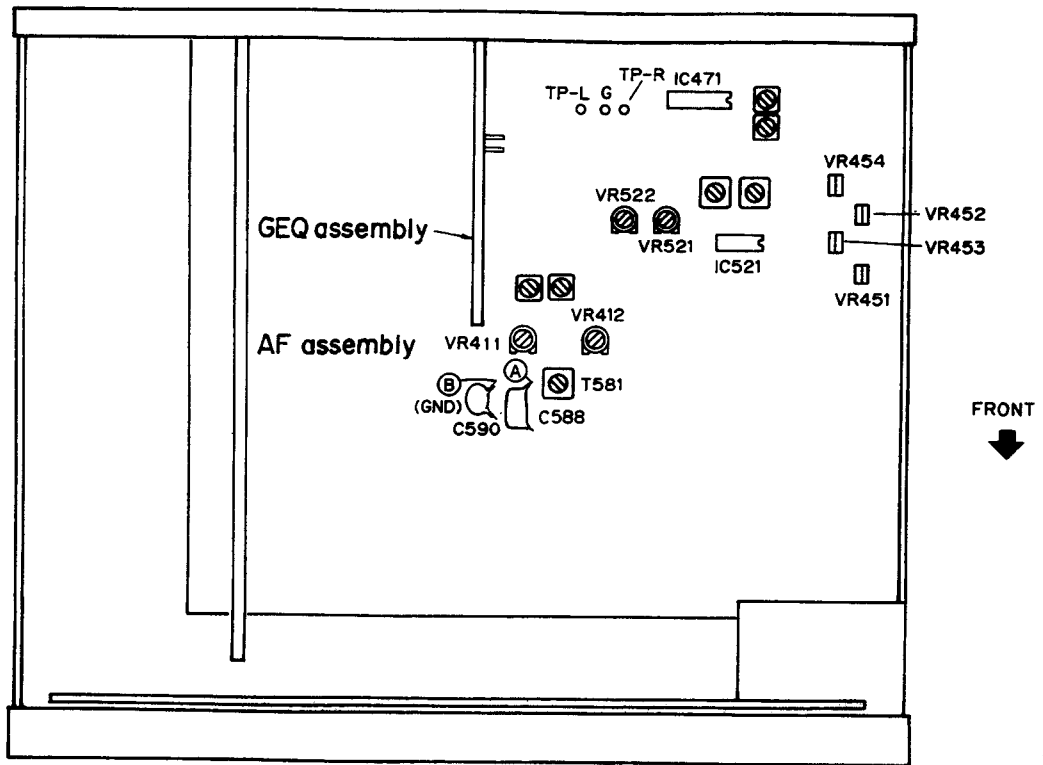

Fig 4.1. Adjustment location

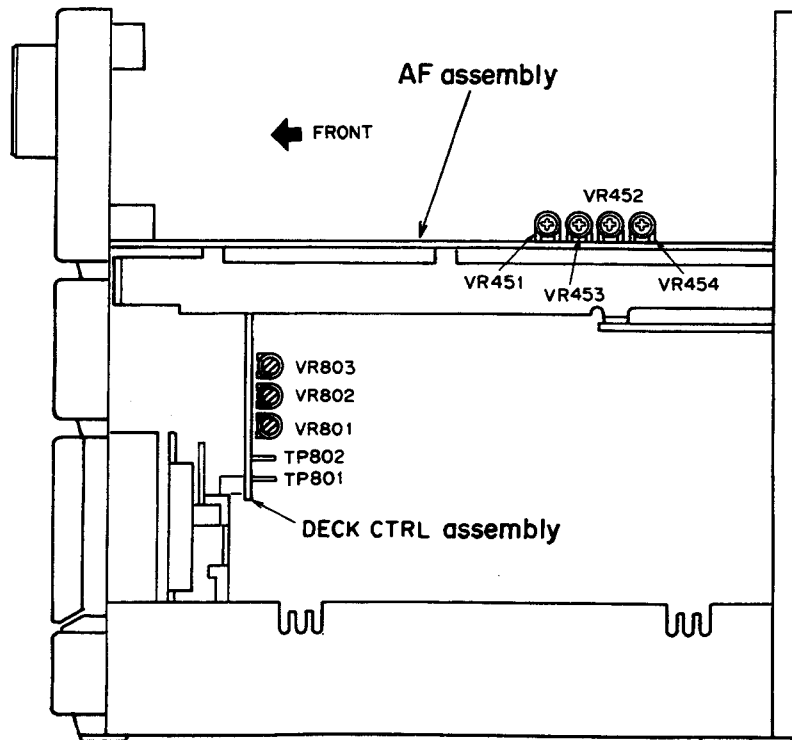

Fig 4.2. Adjustment location

- Adjustment and measurement are usually made in the AF assembly, unless specified otherwise.
- Set the graphic equalizer to OFF, the BALANCE control knob to Center and the MIC LEVEL control knob to MIN.
- The function should always be set to "TAPE" unless otherwise specified.

Adjustment of Mechanical System

- Test tape: STD-301 (3 kHz 30 min)
- Setting of double speed mode: Short-circuit TP801 and TP802 of the DECK CTRL assembly. To release the mode, break the short circuit.

1. Adjustment of tape speed							
No.	Mode	Input signal & Test tape	Adjustment location		Measuring location	Adjustment value	Remarks
1	PLAY	Playback the STD-301 tape to 3 kHz.	Deck I	DECK CTRL Assembly VR801	TP-L (Lch)	Press the PLAY SW and adjust the frequency to 3010 Hz \pm 10 Hz. Make sure that the wow and flutter is within 0.2 %.	
2	PLAY (Double speed mode)			—		Press the PLAY SW in double speed mode and confirm that the frequency is 6000 Hz \pm 1000 Hz. Note down the figure.	Release the double speed mode after adjustment.
3	PLAY (Double speed mode)		Deck II	DECK CTRL Assembly VR803	TP-R (Rch)	Press the PLAY SW in double speed mode and adjust the frequency to be within \pm 30 Hz of the figure recorded at step No. 2.	Release the double speed mode after adjustment.
4	PLAY			DECK CTRL Assembly VR802		Press the PLAY SW and adjust the frequency to 3010 Hz \pm 10 Hz. Make sure that the wow and flutter is within 0.2 %.	

Adjustment of Electric System

■ Check and conduct the following before adjusting the electric system.

1. Adjustment of tape speed has been completed.
2. Clean and demagnetize the head using a head eraser.
3. When measured, the level should be 0 dBV = 1 Vrms.
4. Use side A of the specified tape for adjustment. STD-331B: For adjustment of playback system. STD-630: NORMAL blank tape
5. Prepare the following measuring devices: AC millivoltmeter, Low-frequency oscillator, Attenuator, Oscilloscope
6. Adjust both L and R channels, unless specified otherwise.
7. Set the DOLBY NR switches to OFF, unless specified otherwise.
8. Warm up the unit for several minutes before adjustment. Especially before adjusting the frequency characteristics of recording and playback, warm up for 3 to 5 minutes in REC/PLAY mode.
9. Make sure to follow the proper order of the adjustment procedure. Any change in the order may cause an imperfect result.

List of Adjustment

Deck I

1. Head azimuth adjustment
2. Playback level adjustment

Deck II

1. Head azimuth adjustment
2. Playback level adjustment
3. Bias oscillation frequency adjustment
4. Recording level adjustment
5. Adjustment frequency characteristics of recording / playback

Checking of Deck II

1. Make sure the ALC is operating properly.

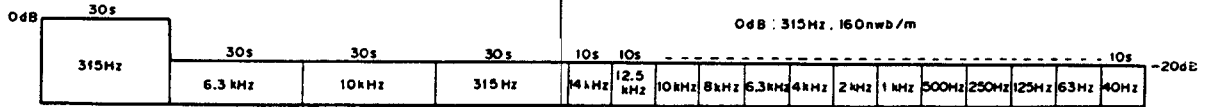

Fig. 4.3 Test tape STD-331B

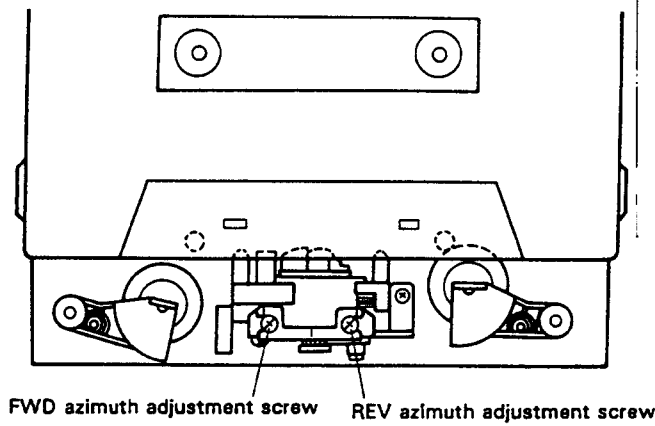

Fig. 4.4 Head azimuth adjustment

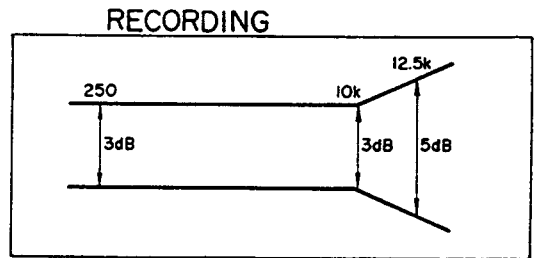
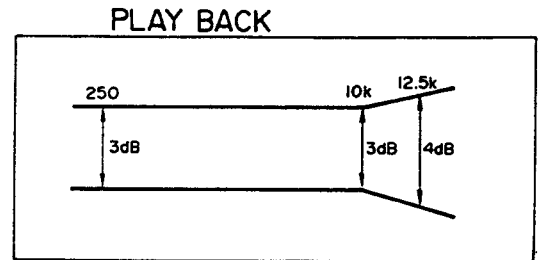

Fig. 4.5 Frequency characteristics

• **Head Adjustment of Deck I**

- Deck I is provided with an automatic tape selector mechanism.
- Note: Do not switch over FWD and REV while the driver is inserted.

1. Head Azimuth Adjustment

Pro-cedure	Tape selector	Mode	Input signal/test tape	Adjustment location	Measuring location	Adjustment value	Remarks
1	NORM	PLAY	Playback the test tape STD-331B (10 kHz, -20 dB).	Head azimuth adjustment screw (Fig. 4-4)	TP-L (Lch) TP-R (Rch)	Maximum playback signal level	Lock the screw with screw lock after completing adjustment.

2. Playback Level Adjustment

- Be sure to make a careful adjustment, as the adjustment determines the DOLBY NR level for playback.

Procedure	Tape selector	Mode	Input signal/test tape	Adjustment location	Measuring location	Adjustment value	Remarks
1	NORM	PLAY	Playback the test tape STD-331B (315 Hz, 0 dB).	VR453 (Lch) VR454 (Rch)	TP-L (Lch) TP-R (Rch)	-6.7 dBV	

• Head Adjustment of Deck II

- Deck II is provided with an automatic tape selector mechanism.
- Note: Do not switch over FWD and REV while the driver is inserted.

1. Head Azimuth Adjustment

Procedure	Tape selector	Mode	Input signal/test tape	Adjustment location	Measuring location	Adjustment value	Remarks
1	NORM	PLAY	Playback the test tape STD-331B (10 kHz, -20 dB).	Head azimuth adjustment screw (Fig. 4-4)	TP-L (Lch) TP-R (Rch)	Maximum playback signal level	Lock the screw with screw lock after completing adjustment.

2. Playback Level Adjustment

- Be sure to make a careful adjustment, as the adjustment determines the DOLBY NR level for playback.

Procedure	Tape selector	Mode	Input signal/test tape	Adjustment location	Measuring location	Adjustment value	Remarks
1	NORM	PLAY	Playback the test tape STD-331B (315 Hz, 0 dB).	VR451 (Lch) VR452 (Rch)	TP-L (Lch) TP-R (Rch)	-6.7 dBV	

3. Bias oscillation frequency adjustment

Procedure	Tape selector	Mode	Input signal/test tape	Adjustment location	Measuring location	Adjustment value	Remarks
1	NORM	REC	Load the test tape STD-630 and set to record mode.	T581	Area between ① and ② (AF Assembly) shown in Fig. 4-1.	The oscillation frequency is 105 kHz \pm 1 kHz.	

4. Recording Level Adjustment

Procedure	Tape selector	Mode	Input signal/test tape	Adjustment location	Measuring location	Adjustment value	Remarks
1	NORM	REC	Apply a signal of 315 Hz to the CD input terminal and set the function to "CD".	Input signal level	TP-L (Lch) TP-R (Rch)	-7.7 dBV	
2	NORM	REC/ PLAY	Record and playback the test tape STD-630 (315 Hz).	VR521 (Lch) VR522 (Rch)	TP-L (Lch) TP-R (Rch)	Repeat the recording and correction so that the playback level of 315 Hz is -6.7 dBV.	

5. Adjustment of frequency characteristics of recording/playback

- As this procedure is for adjustment of the recording bias, be careful not to increase the distortion by under-adjusting the bias.

Procedure	Tape selector	Mode	Input signal/test tape	Adjustment location	Measuring location	Adjustment value	Remarks
1	NORM	REC	Apply a signal of 315 Hz to the CD input terminal and set the function to "CD".	Input signal level	TP-L (Lch) TP-R (Rch)	-27.7 dBV	
2	NORM	REC / PLAY	Record and playback the test tape STD-630 (315 Hz and 10 kHz).	VR411 (Lch) VR412 (Rch)	TP-L (Lch) TP-R (Rch)	Repeat the correction so that the playback level of 10 kHz remains 0 ± 0.5 dB in relation to 315 Hz.	

• Checking Procedure for Deck II

1. Action of ALC

Procedure	Tape selector	Mode	Input signal/test tape	Adjustment location	Measuring location	Checking value	Remarks
1	NORM	REC	Apply a signal of 315 Hz to the CD input terminal and set the function to "CD".	Input signal level	TP-L (Lch) TP-R (Rch)	-7.7 dBV	
2				+10 dB against the input level of step 1.		-2.7 dBV ± 2.5 dB	

4 RÉGLAGE

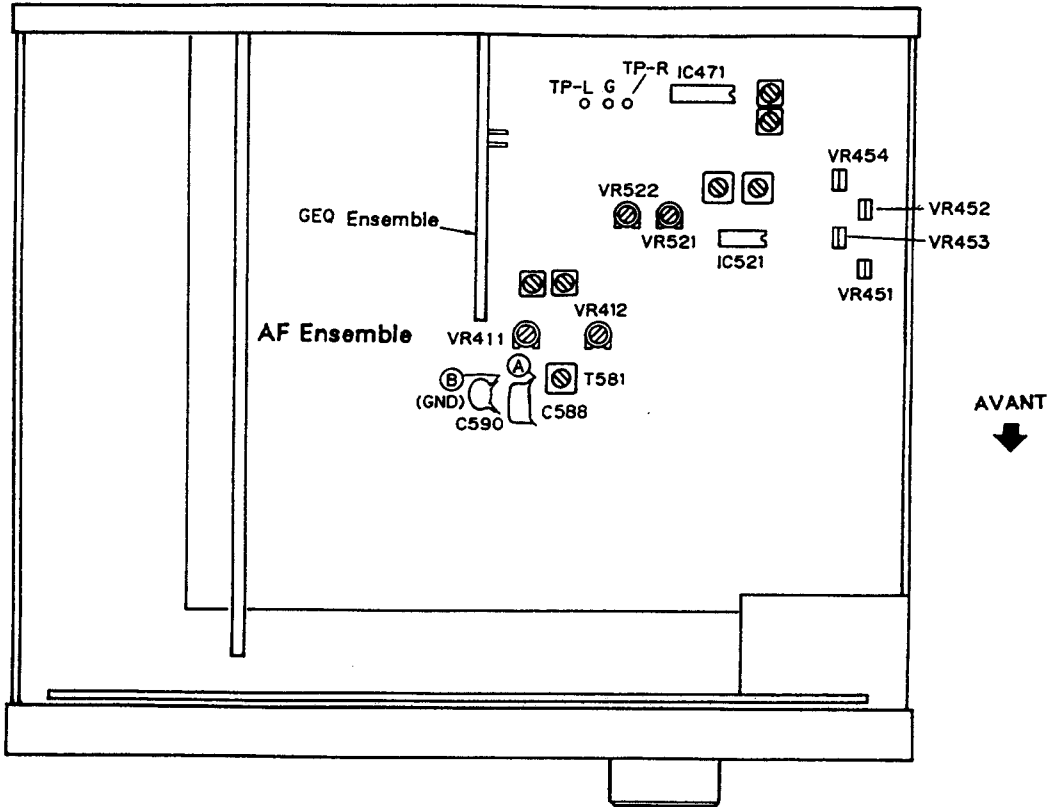

Fig 4.1 Points de réglage

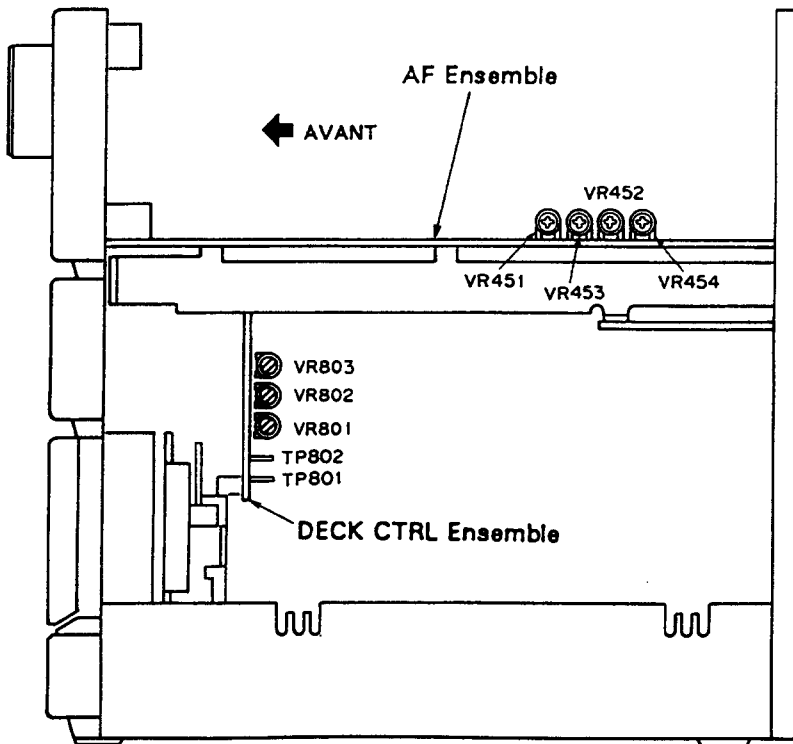

Fig 4.2 Points de réglage

- Les réglages et les mesures sont généralement faits dans l'ensemble AF, à moins de spécification contraire.
- Régler l'égaliseur graphique sur OFF, la commande d'équilibre (BALANCE) en position centrale et le volume de la commande de niveau microphone (MIC LEVEL) sur MIN.
- La fonction doit toujours être réglée sur "TAPE" à moins de spécification contraire.

Réglages mécaniques

- Bande d'étalonnage: STD-301 (3 kHz, 30 mn.)
- Réglage du mode de vitesse double: Court-circuiter TP801 et TP802 de l'ensemble de DECK CTRL. Pour libérer le mode, ouvrir le court-circuit.

1. Réglage de la vitesse de bande							
No.	Mode	Signal appliqué / bande d'étalonnage	Emplacement du réglage		Emplacement du point de mesure	Valeur relevée	Observations
1	PLAY	Reproduire la bande STD-301 par 3 kHz.	Platine I	ENSEMBLE COMM. PLATINE VR801	TP-L (can. G)	Appuyer sur le contacteur PLAY et régler la fréquence sur 3010 Hz \pm 10 Hz. Vérifier que le pleurage et scintillement est dans la limite de 0,2%.	
2	PLAY (Mode de vitesse double)			—		Appuyer sur le contacteur PLAY dans le mode de vitesse double et vérifier que la fréquence est 6000 Hz \pm 1000 Hz. Noter le chiffre.	Libérer le mode de vitesse double après le réglage.
3	PLAY (Mode de vitesse double)		Platine II	ENSEMBLE COMM. PLATINE VR803	TP-R (can. D)	Appuyer sur le contacteur PLAY dans le mode de vitesse double et régler la fréquence pour qu'elle soit dans la limite de \pm 30 Hz du chiffre noté dans l'étape No. 2.	Libérer le mode de vitesse double après le réglage.
4	PLAY			ENSEMBLE COMM. PLATINE VR802		Appuyer sur le contacteur PLAY et régler la fréquence sur 3010 Hz \pm 10 Hz. Vérifier que le pleurage et scintillement est dans la limite de 0,2%.	

Réglages électriques

■ Vérifier les points suivants et effectuer les opérations suivantes avant procéder aux réglages électriques.

1. Le réglage de la vitesse de bande a été complété.
2. Nettoyer et démagnétiser la tête avec un démagnétiseur de tête.
3. Lors de la mesure, le niveau doit être de 0 dBV = 1 Vepp.
4. Utiliser la face A de la bande spécifiée pour le réglage. STD-331B: Pour le réglage du système de lecture. STD-630: Bande vierge NORMAL
5. Préparer les instruments de mesure suivants: Millivoltmètre CA, oscillateur à basse fréquence, éatténuateur et oscilloscope.
6. Régler les deux canaux L (gauche) et R (droit), sauf spécification contraire.
7. Régler les commutateurs DOLBY NR sur la position OFF, sauf spécification contraire.
8. Laisser chauffer l'appareil pendant plusieurs minutes avant le réglage. En particulier avant d'effectuer le réglage de la réponse en fréquence d'enregistrement et de lecture, laisser chauffer l'appareil pendant 3 à 5 minutes dans le mode d'enregistrement/lecture (REC/PLAY).

9. Toujours suivre l'ordre spécifié de la méthode de réglage. Tout changement de l'ordre peut provoquer des résultats imparfaits.

Liste des réglages

Platine I

1. Azimut de la tête
2. Niveau de lecture

Platine II

1. Azimut de la tête
2. Niveau de lecture
3. Réglage de fréquence d'oscillation de polarisation
4. Niveau d'enregistrement
5. Réponse en fréquence d'enregistrement / lecture

Vérification des Platine II

1. Vérifier que le ALC fonctionne correctement.

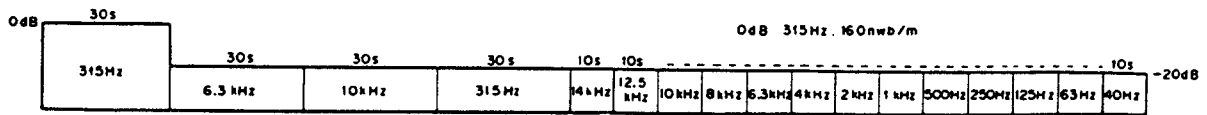

Fig. 4.3 Bande d'étalonnage STD-331B

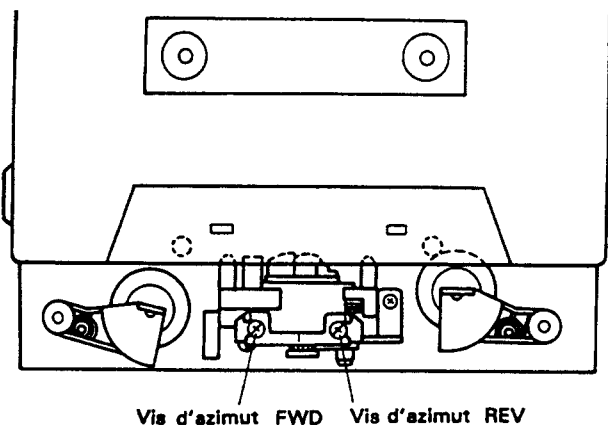

Fig. 4.4 Réglage d'azimut de la tête

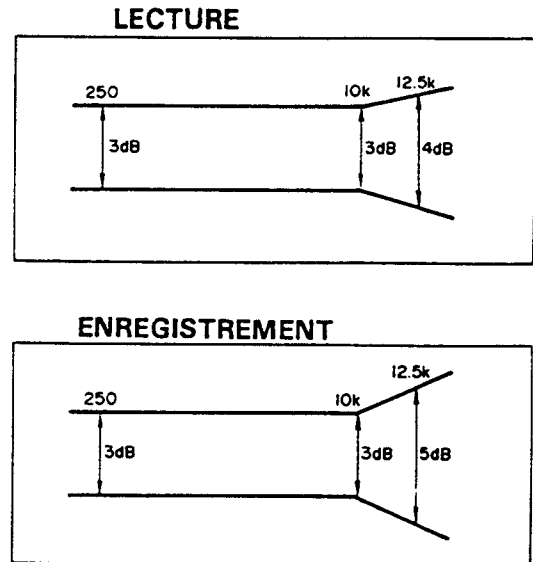

Fig. 4.5 Réponse en fréquence

• Réglage de la Platine I

- La Platine I est équipée d'un mécanisme de sélection automatique de bande.
- Remarque: Ne pas commuter entre le sens avant (FWD) et le sens arrière (REV) pendant que le tournevis est inséré.

1. Réglage d'azimut de la tête

Opération	Sélecteur de bande	Mode	Signal appliqué / bande d'étalonnage	Emplacement du réglage	Emplacement du point de mesure	Valeur mesurée	Observations
1	NORM	PLAY	Reproduire la bande d'étalonnage STD-331B (10 kHz, -20 dB).	Vis de réglage d'azimut de tête (Fig. 4-4)	TP-L (can. G) TP-R (can. D)	Niveau maximum du signal de lecture	Une fois le réglage terminé, bloquer la vis avec un frein de vis.

2. Réglage du niveau de lecture

- Toujours effectuer un réglage minutieux, car la valeur réglée sera le niveau Dolby pour la lecture.

Opération	Sélecteur de bande	Mode	Signal appliqué / bande d'étalonnage	Emplacement du réglage	Emplacement du point de mesure	Valeur mesurée	Observations
1	NORM	PLAY	Reproduire la bande d'étalonnage STD-331B (315 kHz, 0 dB)	VR453 (can. G) VR454 (can. D)	TP-L (can. G) TP-R (can. D)	-6,7 dBV	

• Réglage de la Platine II

- La Platine II est équipée d'un mécanisme de sélection automatique de bande.
- Remarque: Ne pas commuter entre le sens avant (FWD) et le sens arrière (REV) pendant que le tournevis est inséré.

1. Réglage d'azimut de la tête

Opération	Sélecteur de bande	Mode	Signal appliqué / bande d'étalonnage	Emplacement du réglage	Emplacement du point de mesure	Valeur mesurée	Observations
1	NORM	PLAY	Reproduire la bande d'étalonnage STD-331B (10 kHz, -20 dB).	Vis de réglage d'azimut de tête (Fig. 4-4)	TP-L (can. G) TP-R (can. D)	Niveau maximum du signal de lecture	Une fois le réglage terminé, bloquer la vis avec un frein de vis.

2. Réglage du niveau de lecture

- Toujours effectuer un réglage minutieux, car la valeur réglée sera le niveau Dolby pour la lecture.

Opération	Sélecteur de bande	Mode	Signal appliqué / bande d'étalonnage	Emplacement du réglage	Emplacement du point de mesure	Valeur mesurée	Observations
1	NORM	PLAY	Reproduire la bande d'étalonnage STD-331B (315 kHz, 0 dB)	VR451 (can. G) VR452 (can. D)	TP-L (can. G) TP-R (can. D)	-6,7 dBV	

3. Réglage de fréquence d'oscillation de polarisation

Opération	Sélecteur de bande	Mode	Signal appliqué / bande d'étalonnage	Emplacement du réglage	Emplacement du point de mesure	Valeur mesurée	Observations
1	NORM	REC	Charger la bande d'étalonnage STD-630 et régler dans le mode d'enregistrement.	T581	Partie entre ④ et ⑤ (ensemble d'enregistrement (AF)) indiquée sur la Fig. 4-1.	La fréquence d'oscillation est de 105 kHz \pm 1 kHz.	

4. Réglage du niveau d'enregistrement

Opération	Sélecteur de bande	Mode	Signal appliqué / bande d'étalonnage	Emplacement du réglage	Emplacement du point de mesure	Valeur mesurée	Observations
1	NORM	REC	Appliquer un signal de 315 Hz à la borne d'entrée CD et régler la fonction sur "CD".	Niveau du signal d'entrée	TP-L (can. G) TP-R (can. D)	-7,7 dBV	
2	NORM	REC / PLAY	Enregistrer et reproduire la bande d'étalonnage STD-630 (315 Hz).	VR521 (can. G) VR522 (can. D)	TP-L (can. G) TP-R (can. D)	Répéter l'enregistrement et la correction de sorte que le niveau de lecture de 315 Hz soit de -6,7 dBV.	

5. Réglage de la réponse en fréquence d'enregistrement/lecture

- Cette opération réglant la polarisation d'enregistrement, faire attention de ne pas augmenter la distorsion par un réglage insuffisant de la polarisation.

Opération	Sélecteur de bande	Mode	Signal appliqué / bande d'étalonnage	Emplacement du réglage	Emplacement du point de mesure	Valeur mesurée	Observations
1	NORM	REC	Appliquer un signal de 315 Hz à la borne d'entrée CD et régler la fonction sur "CD".	Niveau du signal d'entrée	TP-L (can. G) TP-R (can. D)	-27,7 dBV	
2	NORM	REC / PLAY	Enregistrer et reproduire la bande d'étalonnage STD-630 (315 Hz et 10 kHz).	VR411 (can. G) VR412 (can. D)	TP-L (can. G) TP-R (can. D)	Répéter la correction de sorte que le niveau de lecture de 10 kHz soit de $0 \pm 0,5$ dB en relation avec 315 Hz.	

• Vérification de la Platine II

1. Action du ALC

Opération	Sélecteur de bande	Mode	Signal appliqué / bande d'étalonnage	Emplacement du réglage	Emplacement du point de mesure	Valeur mesurée	Observations
1	NORM	REC	Appliquer un signal de 315 Hz à la borne d'entrée CD et régler la fonction sur "CD".	Niveau du signal d'entrée	TP-L (can. G) TP-R (can. D)	-7,7 dBV	
2				+10 dB par rapport au niveau d'entrée de l'étape 1.		-2,7 dBV $\pm 2,5$ dB	

4. AJUSTE

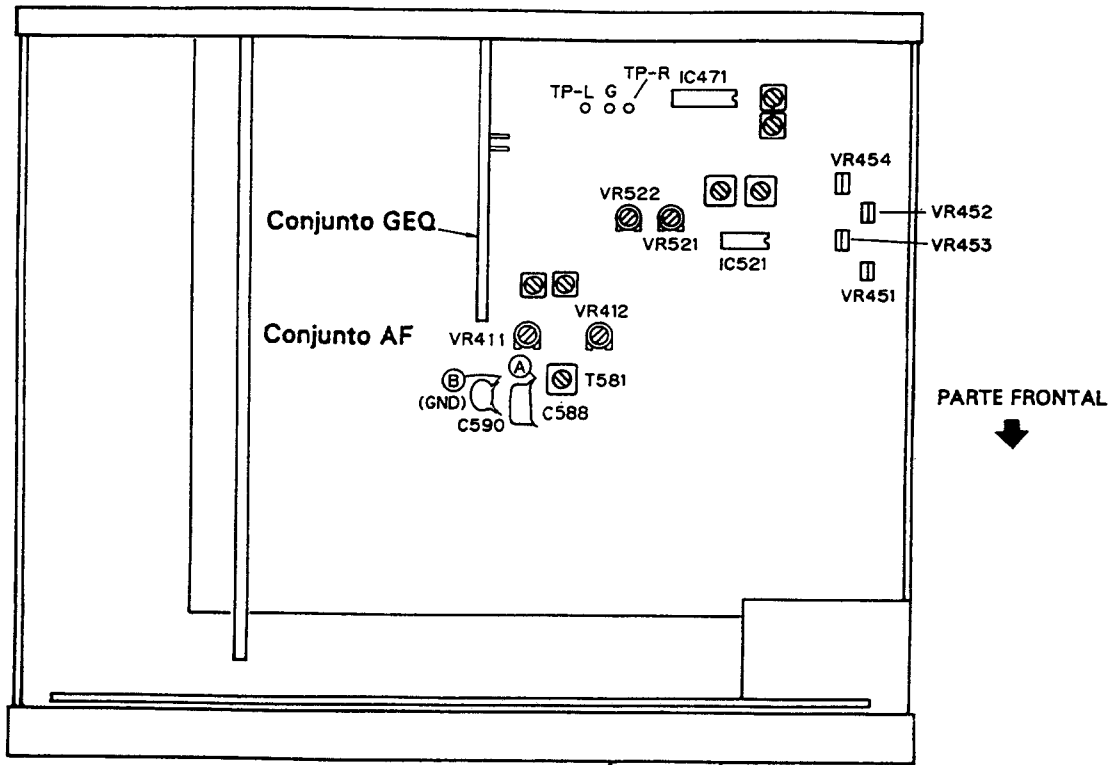

Fig 4.1 Punto de ajuste

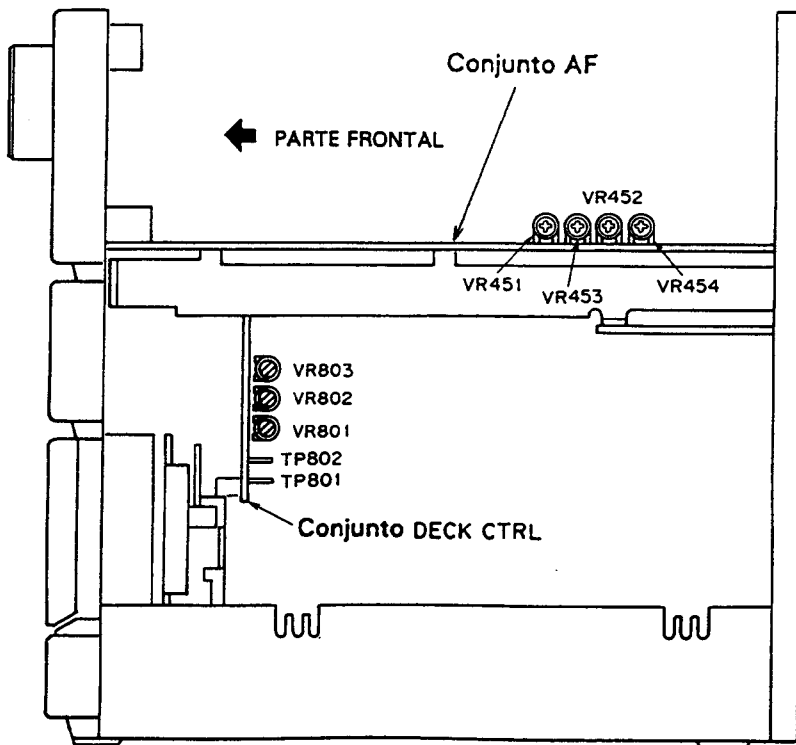

Fig 4.2 Punto de ajuste

- El ajuste y la medición se realizarán normalmente en el conjunto AF, a menos que se especifique otra cosa.
- Desactive (OFF) el ecualizador gráfico, ponga el control BALANCE en el centro, y ajuste el Control MIC LEVEL al mínimo (MIN).
- La función deberá estar ajustada siempre a "TAPE", a menos que se especifique otra cosa.

Ajuste del sistema mecánico

- Cinta de prueba: STD-301 (3 kHz, 30 min)
- Ajuste del modo de velocidad doble: Cortocircuite TP801 y TP802 del conjunto de DECK CTRL. Para desactivar el modo, abra el cortocircuito.

1. Ajuste de la velocidad de la cinta							
Nº	Modo	Señal de entrada/ cinta de prueba	Punto de ajuste		Punto de medición	Valor de ajuste	Observaciones
1	PLAY	Reproducción de la cinta STDy301 a 3 kHz	Sección I	VR801 del conjunto DECK CTRL	TP-L (canal izquierdo)	Presione PLAY SW y ajuste la frecuencia a 3010 Hz \pm 10 Hz. Cerciórese de que la fluctuación y el efecto de trémolo estén dentro de los límites del 0,2%.	
2	PLAY (Modo de velocidad doble)			—		Presione PLAY SW en el modo de velocidad doble y compruebe si la frecuencia es 6000 Hz \pm 1000 Hz. Anote el valor.	Después del ajuste, desactive el modo de velocidad doble.
3	PLAY (Modo de velocidad doble)		Sección II	VR803 del conjunto DECK CTRL	TP-R (canal derecho)	Presione PLAY SW en el modo de velocidad doble y ajuste la frecuencia de forma que quede a \pm 30 Hz del valor anotado en el paso N°2.	Después del ajuste, desactive el modo de velocidad doble.
4	PLAY			VR802 del conjunto DECK CTRL		Presione PLAY SW y ajuste la frecuencia a 3010 Hz \pm 10 Hz. Cerciórese de que la fluctuación y el efecto de trémolo estén dentro de los límites del 0,2%.	

Ajuste del sistema eléctrico

■ Antes de ajustar el sistema eléctrico, compruebe y realice lo siguiente.

1. El ajuste de la velocidad de la cinta ha finalizado.
2. Limpie y desmagnetice la cabeza empleando un desmagnetizador de cabezas.
3. Cuando se mida, el nivel de nivel debe ser de 0 dBV = 1V rms.
4. Emplee el lado A de la cinta especificada para realizar el ajuste.
STD-331B: Para ajuste del sistema de reproducción.
STD-630: Cinta en blanco NORMAL
5. Prepare los dispositivos de medición siguientes: Milivoltímetro de CA, oscilador de baja frecuencia, atenuador, y osciloscopio
6. Ajuste ambos canales, izquierdo y derecho, a menos que se especifique otra cosa.
7. Ponga los interruptores DOLBY NR en OFF, a menos que se especifique otra cosa.
8. Antes del ajuste, deje que la unidad se caliente durante varios minutos.
Especialmente antes de ajustar las características de frecuencia de grabación y reproducción, deje que se caliente durante 3 a 5 minutos en el modo REC/PLAY.

9. Cerciórese de seguir el orden apropiado del procedimiento de ajuste. Cualquier cambio en el orden podría causar un resultado imperfecto.

Lista de ajuste

Sección I

1. Azimut de la cabeza
2. Nivel de reproducción

Sección II

1. Azimut de la cabeza
2. Nivel de reproducción
3. Ajuste de la frecuencia de oscilación de polarización
4. Nivel de grabación
5. Características de frecuencia de grabación/reproducción

Comprobación de la sección II

1. Cerciórese de que ALC esté funcionando adecuadamente.

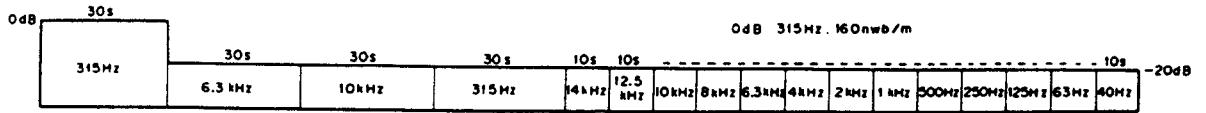
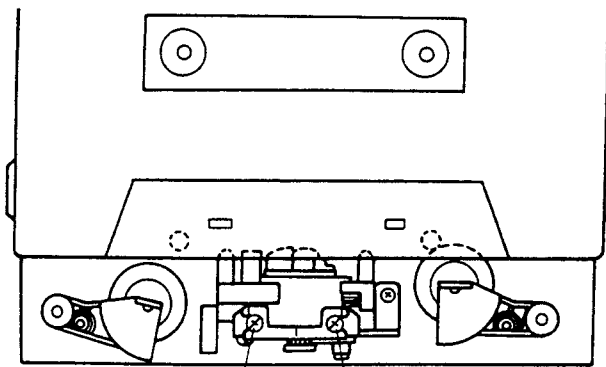

Fig. 4.3 Cinta de prueba STD-331B



Tornillo de ajuste azimut de FWD Tornillo de ajuste azimut de REV

Fig. 4.4 Ajuste del azimut de la cabeza

REPRODUCCIÓN

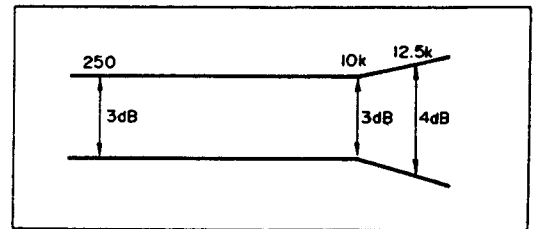

CRABACIÓN

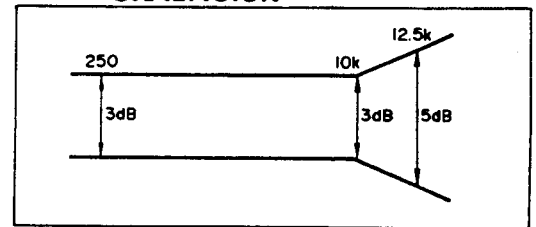

Fig. 4.5 Características de frecuencia

• Ajuste de la sección I

- La sección I dispone de un mecanismo selector automático de cinta.
- Nota: No cambie a FWD ni a REV mientras el destornillador esté insertado.

1. Ajuste azimutal de la cabeza

Procedimiento	Selector de cinta	Modo	Señal de entrada / cinta de prueba	Punto de ajuste	Punto de medición	Valor de ajuste	Observaciones
1	NORM	PLAY	Ponga la cinta de prueba STD-331B en reproducción (10 kHz, -20 dB).	Tornillo de ajuste azimutal de la cabeza (Fig. 4-4)	TP-L (canal izquierdo) TP-R (canal derecho)	Nivel máximo de la señal de reproducción	Bloquee el tornillo con bloqueador de tornillos después de haber terminado el ajuste.

2. Ajuste del nivel de reproducción

- Tenga mucho cuidado durante el ajuste, ya que el valor ajustado será el nivel Dolby fijado para reproducción.

Procedimiento	Selector de cinta	Modo	Señal de entrada / cinta de prueba	Punto de ajuste	Punto de medición	Valor de ajuste	Observaciones
1	NORM	PLAY	Ponga la cinta de prueba STD-331B en reproducción (315 Hz, 0 dB).	VR453 (canal izquierdo) VR454 (canal derecho)	TP-L (canal izquierdo) TP-R (canal derecho)	-6,7 dBV	

• Ajuste de la sección II

- La sección II dispone de un mecanismo selector automático de cinta.
- Nota: No cambie a FWD ni a REV mientras el destornillador esté insertado.

1. Ajuste azimutal de la cabeza

Procedimiento	Selector de cinta	Modo	Señal de entrada / cinta de prueba	Punto de ajuste	Punto de medición	Valor de ajuste	Observaciones
1	NORM	PLAY	Ponga la cinta de prueba STD-331B en reproducción (10 kHz, -20 dB).	Tornillo de ajuste azimutal de la cabeza (Fig. 4-4)	TP-L (canal izquierdo) TP-R (canal derecho)	Nivel máximo de la señal de reproducción	Bloquee el tornillo con bloqueador de tornillos después de haber terminado el ajuste.

2. Ajuste del nivel de reproducción

- Tenga mucho cuidado durante el ajuste, ya que el valor ajustado será el nivel Dolby fijado para reproducción.

Procedimiento	Selector de cinta	Modo	Señal de entrada / cinta de prueba	Punto de ajuste	Punto de medición	Valor de ajuste	Observaciones
1	NORM	PLAY	Ponga la cinta de prueba STD-331B en reproducción (315 Hz, 0 dB).	VR451 (canal izquierdo) VR452 (canal derecho)	TP-L (canal izquierdo) TP-R (canal derecho)	-6,7 dBV	

3. Ajuste de la frecuencia de oscilación de polarización

Procedimiento	Selector de cinta	Modo	Señal de entrada / cinta de prueba	Punto de ajuste	Punto de medición	Valor de ajuste	Observaciones
1	NORM	REC	Cargue la cinta de prueba STD-630 y establezca el modo de grabación.	T581	Área entre ④ y ⑤ (conjunto de AF) mostrada en la Fig. 4-1.	La frecuencia de oscilación es de 105 kHz \pm 1 kHz.	

4. Ajuste del nivel de grabación

Procedimiento	Selector de cinta	Modo	Señal de entrada / cinta de prueba	Punto de ajuste	Punto de medición	Valor de ajuste	Observaciones
1	NORM	REC	Aplique una señal de 315 Hz al terminal de entrada CD y ajuste la función a "CD".	Nivel de la señal de entrada	TP-L (canal izquierdo) TP-R (canal derecho)	-7,7 dBV	
2	NORM	REC / PLAY	Grabe y reproduzca la cinta de prueba STD-630 (315 Hz).	VR521 (canal izquierdo) VR522 (canal derecho)	TP-L (canal izquierdo) TP-R (canal derecho)	Grabe y reproduzca la cinta de prueba de forma que el nivel de reproducción de 315 Hz sea de -6,7 dBV.	

5. Ajuste de las características de frecuencia de grabación/reproducción

- Como este procedimiento es para el ajuste de la polarización de grabación, tenga cuidado de no aumentar el valor de distorsión mediante el subajuste de la polarización.

Procedimiento	Selector de cinta	Modo	Señal de entrada / cinta de prueba	Punto de ajuste	Punto de medición	Valor de ajuste	Observaciones
1	NORM	REC	Aplique una señal de 315 Hz al terminal de entrada CD y ajuste la función a "CD".	Nivel de la señal de entrada	TP-L (canal izquierdo) TP-R (canal derecho)	-27,7 dBV	
2	NORM	REC/PLAY	Grabe y reproduzca la cinta de prueba STD-630 (315 Hz y 10 kHz).	VR411 (canal izquierdo) VR412 (canal derecho)	TP-L (canal izquierdo) TP-R (canal derecho)	Repita la corrección de forma que el nivel de reproducción de 10 kHz sea de $0 \pm 0,5$ dB en relación con 315 Hz.	

• Procedimiento de comprobación para sección II

1. Acción del ALC

Procedimiento	Selector de cinta	Modo	Señal de entrada / cinta de prueba	Punto de ajuste	Punto de medición	Valor de ajuste	Observaciones
1	NORM	REC	Aplique una señal de 315 Hz al terminal de entrada CD y ajuste la función a "CD".	Nivel de la señal de entrada	TP-L (canal izquierdo) TP-R (canal derecho)	-7,7 dBV	
2				+10 dB contra el nivel de entrada del paso 1.		-2,7 dBV $\pm 2,5$ dB	

5. FOR HE TYPE

CONTRAST OF MISCELLANEOUS PARTS

NOTES:

- Parts without part number cannot be supplied.
- The \triangle mark found on some component parts indicates the importance of the safety factor of the part. Therefore, when replacing, be sure to use parts of identical designation.
- Parts marked by "⊙" are not always kept in stock. Their delivery time may be longer than usual or they may be unavailable.

The DC-Z83/HE type is the same as the DC-Z83/HB type with the exception of the following sections.

Mark	Symbol & Description	Part No.		Remarks
		HB type	HE type	
	POWER SUPPLY assembly	AWZ2241	AWZ2239	
	CONNECT assembly	Non supply	Non supply	
\triangle	FU2001 Fuse (T2A/250V)	AEK-511	
\triangle	FU2001 Fuse (T1.25A/250V)	AEK-018	
\triangle	FU2004 Fuse (T1.25A/250V)	AEK-509	
\triangle	FU2004 Fuse (T2A/250V)	AEK-017	
\triangle	FU2003 Fuse (T1.6A/250V)	AEK-510	AEK-405	
\triangle	FU2005 Fuse (T1.25A/250V)	AEK-509	AEK-018	
\triangle	AC Power cord	ADG1052	ADG1049	
	Operating instructions (English)	ARB1222	
	Operating instructions (Dutch, Swedish, Spanish, Portuguese)	ARC1181	
	Operating instructions (English, German, French, Italian)	ARE1145	

POWER SUPPLY assembly (AWZ2239)

The POWER SUPPLY assembly (AWZ2239) is the same as the POWER SUPPLY assembly (AWZ2241) with the exception of the following sections.

Mark	Symbol & Description	Part No.		Remarks
		AWZ2241	AWZ2239	
\triangle	AC socket (OUTLET)	AKP1035	AKP1034	

CONNECT assembly

The difference in parts between the CONNECT assemblies HB type and HE type is only the jumper wire.

6. PANES FACILITIES

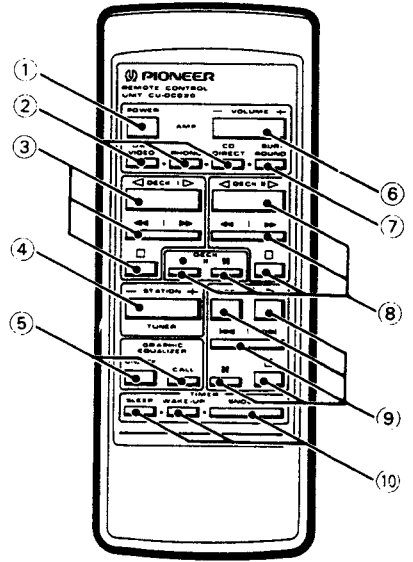
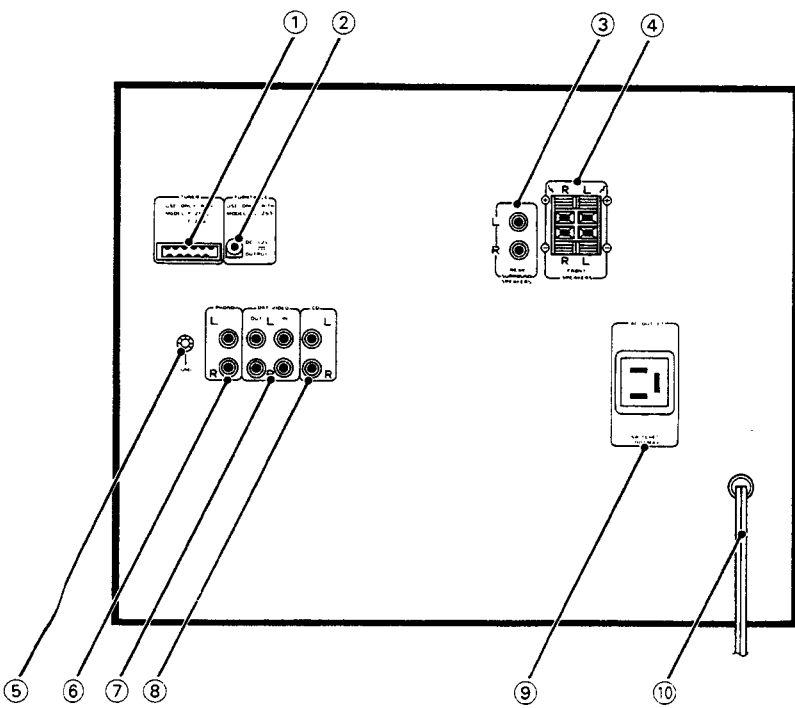
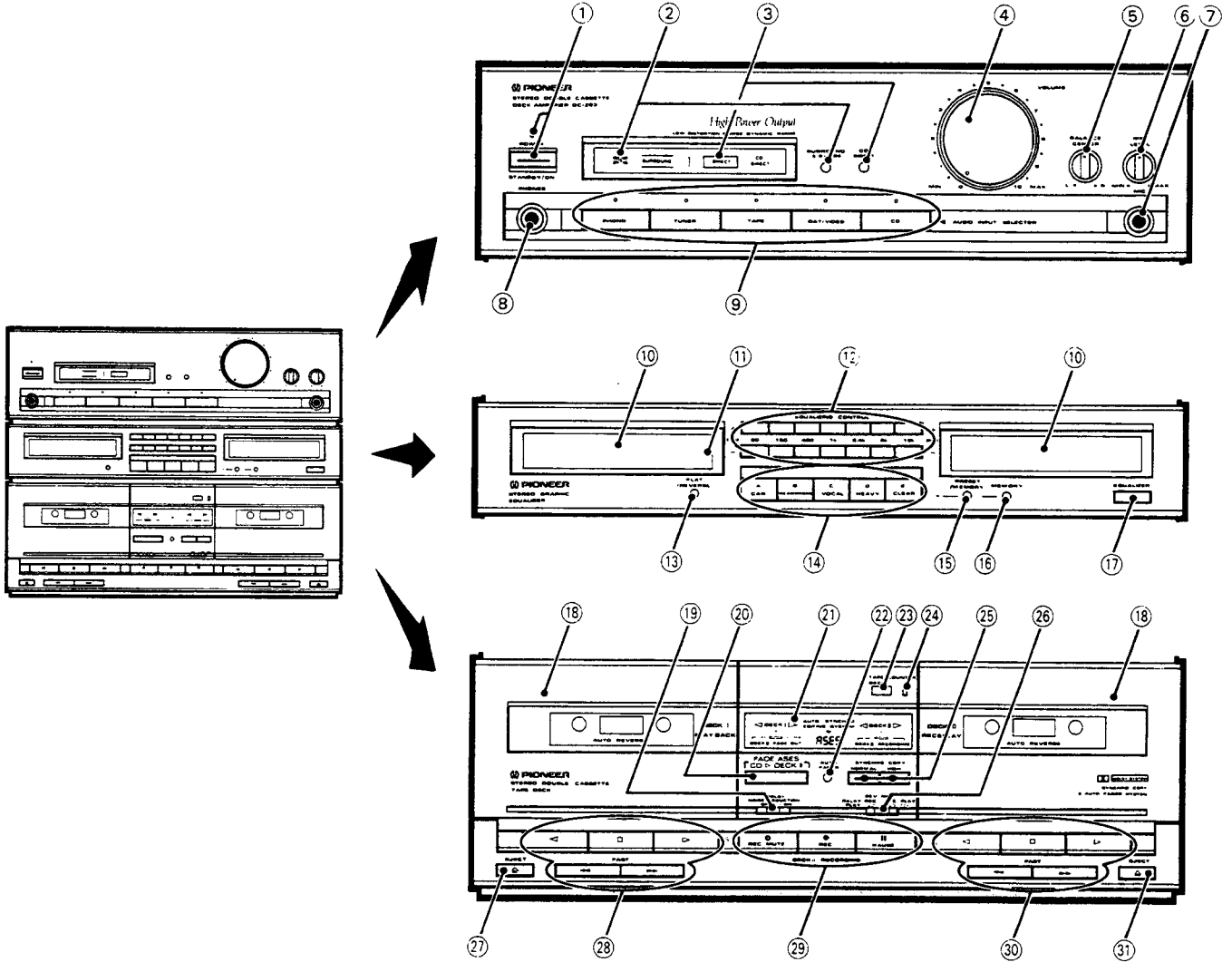

REAR PANEL FACILITIES

① TUNER jacks

Connect the tuner cord here.

② TURNTABLE (DC 12 V OUTPUT) jack

This jack supplies power to the turntable (PL-Z93).

③ SURROUND SPEAKERS jacks

Connect the Surround speaker systems.

NOTE:

Connect a speaker system having a nominal impedance of 16 Ω or more.

④ SPEAKERS terminals

L: Connect the left speaker system as seen from the listening position.

R: Connect the right speaker system as seen from the listening position.

NOTE:

Connect a speaker system having a nominal impedance ranging from 6 Ω to 16 Ω .

⑤ Ground terminal (GND)

Connect this to the ground terminal on the turntable (except for PL-Z93).

⑥ PHONO input jacks

Connect the output cord of the turntable to these jacks.

⑦ DAT/VIDEO jacks

IN: Connect to audio output jacks of DAT, LD player or VCR, etc.

OUT: Connect to audio input jacks of DAT or VCR, etc.

⑧ CD input jacks

Connect to output jacks of a CD player.

⑨ AC OUTLET (SWITCHED 100 W MAX)

Power supplied through this outlet is turned on and off by the cassette tape deck amplifier's POWER switch. Total electrical power consumption of connected equipment should not exceed 100 W.

NOTE:

Do not connect appliances with high power consumption such as heaters, irons, or television sets to the AC OUTLET in order to avoid overheating or fire risk.

This can cause the cassette tape deck amplifier to malfunction.

⑩ Power cord

Connect this to the AC wall socket.

FRONT PANEL FACILITIES

- This unit has an automatic tape type selector.
- Tapes can be played back on Deck I; tapes can be played back and recorded on Deck II.
- Sound can be recorded as adjusted by the graphic equalizer.

■ Amplifier section

① POWER STANDBY/ON switch/indicator

This is the switch for electric power.

ON: When set to the ON position, power is supplied and the unit becomes operational.
The POWER indicator lights.

STANDBY: When set to the STANDBY position, the main power flow is cut and the unit is no longer fully operational. A minute flow of power feeds the unit to maintain operation readiness.

When the POWER indicator is off, the unit is in STANDBY. (The tuner display shows only the time.)

② SURROUND & STEREO WIDE switch/indicator

By turning this switch ON, you can enjoy surround reproduction when rear speakers are used.

By turning this switch ON, you can enjoy STEREO WIDE reproduction with greater left-right spread when rear speakers are not used.

The indicator lights when the switch is on.

NOTE:

- In the case of monaural source, SURROUND & STEREO WIDE effects cannot be obtained.
- SURROUND & STEREO WIDE functions do not operate if CD DIRECT is on.

③ CD DIRECT switch/indicator

Press this switch to listen to a CD without passing the signal through sound quality adjustment circuits.

④ VOLUME control

⑤ BALANCE control

Used for changing the balance between left and right channels. Usually set this control to the centre position.

⑥ MIC LEVEL control

Used for adjusting the volume of microphone.

⑦ MIC (Microphone) jack

This is a standard jack for connecting a microphone.

⑧ PHONES (Headphones) jack

For stereo headphones.

NOTE:

There is no output from the speakers when headphones are plugged into PHONES jack.

⑨ Input selector switches/indicators

[PHONO]

Press to play records on a turntable connected to the PHONO jacks.

[TUNER]

Press to listen to radio broadcast.

[TAPE]

Press to listen to cassette tape.

[DAT/VIDEO]

Press to listen to digital audio tape.

[CD]

Press to listen to a CD player connected to the CD jacks.

■ Graphic Equalizer section

⑩ Graphic equalizer/Spectrum analyzer display

Usually this is the spectrum analyzer display. And becomes a graphic equalizer display during operation of the EQUALIZING CONTROL switches.

11 MODE display

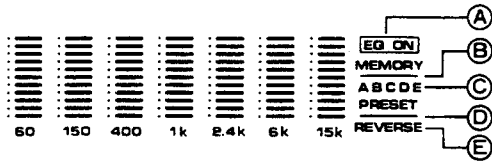

A EQ ON indicator

Lights when the EQUALIZER switch is set to ON. When this indicator is lit, the graphic equalizer can be used to adjust sound quality.

B MEMORY indicator

When the line under "MEMORY" is lit, it indicates that the equalization curves you input in the memory recall switches can be recalled.

C A - E indicators

Indicates which equalization curve is currently recalled.

- A: Curve stored in A/CAR. (Preset CAR or Memory A)
- B: Curve stored in B/HEADPHONE. (Preset HEADPHONE or Memory B)
- C: Curve stored in C/VOCAL. (Preset VOCAL or Memory C)
- D: Curve stored in D/HEAVY. (Preset HEAVY or Memory D)
- E: Curve stored in E/CLEAR. (Preset CLEAR or Memory E)

D PRESET indicator

When the line under "PRESET" is lit, it indicates that the equalization factory curves preset in the memory recall switches can be recalled.

E REVERSE indicator

Lights when FLAT/REVERSE switch is used to invert the equalization curve.

12 EQUALIZING CONTROL switches

These strengthen or weaken the indicated frequency band. Press the upper switch to emphasize; press the lower switch to attenuate.

13 FLAT/REVERSE switch

Press once to reset the equalizer to flat response (no equalization). Press again to reverse a previous curve (boosted frequencies will be attenuated, and vice versa).

14 Memory recall switches

Used for recalling equalization curves.

15 PRESET/MEMORY switch

Determines whether the equalizer curves recalled by the Memory recall switches are your memorized curves or factory preset curves.

16 MEMORY switch

Used for storing equalization curves you input in the memory recall switches.

17 EQUALIZER switch

Turns the equalizer on and off. The EQ ON indicator lights when this switch is on. The equalizer can not be used to adjust the sound when CD DIRECT is on.

■ Cassette Tape Deck Section

18 Cassette door

19 DOLBY* NR switch

Set this switch to the ON position to activate the DOLBY NR system.

- Tapes recorded using Dolby noise reduction should always be played back with the noise reduction system on. Sound quality will be adversely affected if played back with the system off, or if tapes recorded using a different noise reduction system are played back with the Dolby NR system on.

- It is recommended that tapes recorded with Dolby B type NR be so marked on the label. This will help prevent incorrect setting of the noise reduction switch during playback.

*
Dolby noise reduction manufactured under license from Dolby Laboratories Licensing Corporation. "DOLBY" and the double-D symbol are trademarks of Dolby Laboratories Licensing Corporation.

20 AUTO SYNCHRO EDITING SYSTEM switch

Used for automatically recording a CD on cassette tape. The sound will fade out at the end of the tape.

21 Operation indicators

- DECK II FADE OUT: Lights when AUTO FADE OUT mode is on.
- ASES: Lights when the ASES (Auto Synchro Editing System) is operating.
- DECK II RECORDING: Lights when recording. Flashes when copying a tape.
 - Slow flashing — Normal copy
 - Rapid flashing — High speed copy
- Direction (<, >): Indicates direction of tape travel during recording or playback. Flashes slowly in pause mode. Flashes rapidly during Music Search (MS).

22 AUTO FADER switch

Used for gradually fading out a recorded tape in Deck II. (The sound will be completely cut off after approximately 10 seconds and the tape will stop.)

23 Tape counter (DECK II)

24 Counter reset switch

Press this switch to reset the Deck II tape counter display to 000.

25 SYNCHRO COPY switches

Used for tape copying.

- NORMAL: Copying from the Deck I tape to the Deck II tape at normal recording/playback speed.
- HIGH: Copying at about twice normal tape speed. (Copies can be made in about half the NORMAL time.)

26 REV (REVERSE) MODE switch

Switch position	During playback	During recording
RELAY REC PLAY	Plays both tape sides. When one deck finishes playback, the other deck begins playback of both tape sides for 6 times. If there is a tape in only one deck, then that deck continuously plays both sides of the tape for 6 times.	Records on one side (Deck II only).
REC PLAY 	Plays both tape sides for 6 times maximum.	Records on both sides (Deck II only).

27 Deck I EJECT switch

28 Deck I Operation switches

- ▷ **PLAY (FWD)** For playing back a tape in the forward mode.
- ◁ **PLAY (REV)** For playing back a tape in the reverse mode.
- **STOP** For stopping the tape.
- ▶▶ **FAST** Fast forward in forward mode, rewind in reverse mode.
Music search (MS) starts if this is pressed during playback.
- ◀◀ **FAST** Rewind in forward mode, fast forward in reverse mode.
Music search (MS) starts if this is pressed during playback.

29 DECK II RECORDING switches

- MUTE (○)** Used for creating a blank space between songs. The unrecorded space is created for as long as this switch is kept depressed.
- REC (●)** To set to recording standby mode. Recording begins when you press the PLAY switch (◁ or ▷).
- PAUSE (□□)** Temporarily stops tape travel. Cancels pause mode when pressed again or press the PLAY switch.

30 Deck II Operation switches: Same as Deck I operation switches 28

31 Deck II EJECT switch

Remote control unit

1 POWER key

2 Function keys

- DAT/VIDEO** Sets function to DAT/VIDEO.
- PHONO** Sets function to PHONO.
- CD DIRECT** Sets function to CD DIRECT.

3 DECK I operation keys: Same as the Deck I operation switches 28

4 TUNER STATION key

- Before operation, memorize broadcast stations in the STATION CALL switches.
- + ... Stations change in order in the upward direction
- ... Stations change in order in the downward direction.

5 GRAPHIC EQUALIZER operation keys.

- ON/OFF:** Turns the equalizer on and off.
- CALL:** Recalls the preset equalization curves (PRESET) and memorized equalization curves (MEMORY) in sequence.

6 VOLUME + (UP)/- (DOWN) key

When pressed, VOLUME on the amplifier is actually moved by a motor.

7 SURROUND key

Turns SURROUND & STEREO WIDE on and off.

8 Deck II operation keys: Same as Deck I operation switches 28 plus Deck II recording switch 29 (except for MUTE).

9 CD operation keys

Perform the connections so that the CD player is operated by the remote control unit.

- ▷ Play
- DISC** DISC selection
- Stop
- Pause
- ◀◀, ▶▶ Track search

NOTE:

Note that the DISC selector key on the remote control unit may not operate, depending on the CD player used.

10 Timer operation keys

- SLEEP:** Sets the sleep timer. Each time you press this key, the setting changes as shown here. The current setting is shown on the tuner display. Power turns off when your set time has elapsed.

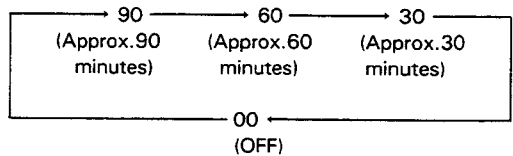

If you press the SLEEP key during SLEEP operation, the display will show the time remaining till power turns off.

- WAKE-UP:** Timer playback setting/cancellation can be performed when the timer playback time has been set. This is shown in the tuner display section.

- SNOOZE:** Turns off power if pressed after timer playback begins. Timer playback begins again approx. 5 minutes later.

The amplifier input selector automatically switches to the music source being operated when you press the CD playback (▷), cassette tape deck playback (◁, ▷), or tuner station controls.

NOTE:

It is not possible to operate the CD player with the remote control unless the remote control cord is connected

Range of remote control

When the remote control unit is pointed at the remote sensor window on the tuner and any of its keys is pressed, the tuner and other components can be operated by remote control.

Distance: Within a range of approx. 7 meters from the remote sensor window on the tuner.

Angle: Within approx. 30 degrees from the center of the remote sensor window on the tuner.

Remote control will not be possible if there is an obstacle between the remote control unit itself and the remote sensor window on the tuner.

Performance of the remote control unit is adversely affected in the presence of strong fluorescent light. Keep such lights away, specially from the sensor window.

7. SPECIFICATIONS

Cassette tape deck amplifier: DC-Z83

Amplifier Section

Continuously Average Power Output is 35 Watts* per channel, min., at 8 ohms from 40 Hertz to 20,000 Hertz, with no more than 0.4 % total harmonic distortion.

* Measured pursuant to the Federal Trade Commission's Trade Regulation rules on Power Output Claims for Amplifiers.

Music power	75 W + 75 W (1 kHz, T.H.D. 1 %, 8 Ω)
Music power (DIN)	75 W + 75 W (1 kHz, T.H.D. 1 %, 8 Ω)
Peak music power	450 W (1 kHz, T.H.D. 10 %, 6 Ω)
Continuous Power Output (DIN)	45 W + 45 W (1 kHz, T.H.D. 1 %, 8 Ω)
Graphic equalizer frequency band	60 Hz, 150 Hz, 400 Hz, 1 kHz, 2.4 kHz, 6 kHz, 15 kHz, ± 7 dB
Signal-to-Noise Ratio (IHF, short-circuited, A network) PHONO	72 dB
Signal-to-Noise Ratio (DIN, continuous Power/50 mW) PHONO	68 dB/60 dB
Total Harmonic Distortion (40 Hz to 20,000 Hz, 20 W, 8 ohms)**	No more than 0.2 %

Tape Deck Section

Systems	4 track, 2-channel stereo
Heads	Recording/playback head x 1 Playback head x 1 Erasing head x 1
Motor	DC servo 2 speed motor x 2
Wow and Flutter	No more than 0.09 % (WRMS)
Fast Winding Time	Approximately 95 seconds (C-60 tape)
Frequency Response (- 20 dB recording):	
Normal tape	35 Hz to 14,000 Hz ± 6 dB
CrO ₂ tape	35 Hz to 15,000 Hz ± 6 dB
Metal tape	35 Hz to 16,000 Hz ± 6 dB
Signal-to-Noise ratio Dolby NR OFF	56 dB
Noise Reduction Effect Dolby B type NR ON	More than 10 dB (at 5 kHz)

Furnished Parts

Operating Instructions	1
Remote control unit	1
Dry cell batteries	2

Miscellaneous

Power requirements	
U.K. and Australian models	a.c. 240 Volts ~, 50/60 Hz
Other destination models	AC 110/120-127/220/240 V (switchable) 50/60 Hz
Power Consumption	336 W
Dimensions	360 (W) x 287 (H) x 329 (D) mm 14-3/16 (W) x 11-5/16 (H) x 12-15/16 (D) in
Weight (without package)	9 kg (19 lb 14 oz)

Accessories

EP Adaptor	1
------------------	---

• Specifications and design subject to possible modification without notice due to improvement.

** Measured By Audio Spectrum Analyzer.