

Service Manual

PIONEER
The future of sound and vision.

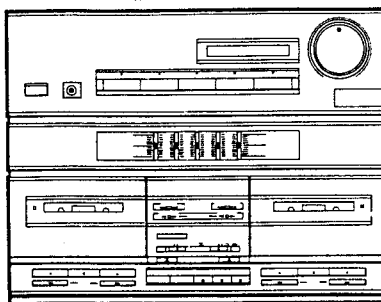

**ORDER NO.
ARP1689**

STEREO DOUBLE CASSETTE TAPE DECK AMPLIFIER

DC-Z72

MODEL DC-Z72 HAS FIVE VERSIONS:

Type	Power requirement	Export destination
HB	AC220V,240V (switchcable)*	United Kingdom
HE	AC220V,240V (switchcable)*	European continent
HEZ	AC220V,240V (switchcable)*	West Germany
SD	AC110V,120V-127V,220V,240V (switchcable)	Kingdom of Saudi Arabia and general market
YP	AC240V only	Australia

*Change the jumper wires of assembly boards.

- This manual is applicable to the DC-Z72/HB and HE types.
- For HE type, refer to pages 71-72.
- For the other types, refer to additional service manuals.
- Ce manuel pour le service comprend les explications en français de réglage.
- Este manual de servicio trata del método ajuste escrito en español.

CONTENTS

1. SPECIFICATIONS	2	6. ADJUSTMENTS	54
2. P.C. BOARDS LOCATION	3	RÉGLAGE	58
3. EXPLODED VIEWS, PACKING AND PARTS LIST	6	AJUSTE	63
4. SCHEMATIC DIAGRAM AND P.C. BOARDS CONNECTION DIAGRAM	18	7. IC INFORMATION	68
5. ELECTRICAL PARTS LIST	49	8. FOR HE TYPE	71
		9. CONNECTIONS	73
		10. PANEL FACILITIES	75

PIONEER ELECTRONIC CORPORATION 4-1, Meguro 1-Chome, Meguro-ku, Tokyo 153, Japan
PIONEER ELECTRONICS SERVICE INC. P.O. Box 1760, Long Beach, California 90801 U.S.A.
PIONEER ELECTRONICS OF CANADA, INC. 505 Cochrane Drive, Markham, Ontario L3R 8E3 Canada
PIONEER ELECTRONIC [EUROPE] N.V. Keetberglaan 1, 2740 Beveren, Belgium
PIONEER ELECTRONICS AUSTRALIA PTY. LTD. 178-184 Boundary Road, Braeside, Victoria 3195, Australia TEL: [03] 580-9911
© PIONEER ELECTRONIC CORPORATION 1989

YV JAN.1989 Printed in Japan.

1. SPECIFICATIONS

Cassette tape deck amplifier: DC-Z72

AMPLIFIER SECTION

Continuous Average Power Output is 27 Watts* per channel, min., at 8 ohms from 40 Hertz to 20,000 Hertz, with no more than 0.3% total harmonic distortion.

**Measured pursuant to the Federal Trade Commission's Trade Regulation rules on Power Output Claims for Amplifiers.*

Music power 50 W + 50 W (1 kHz, T.H.D. 1 %, 8 ohms)
 DIN music power..... 50 W + 50 W (1 kHz, T.H.D. 1%, 8 ohms)
 Peak music power..... 290 W
 Continuous power output (DIN)..... 33 W + 33 W
 (1 kHz, T.H.D. 1 %, 8 ohms)
 Graphic equalizer frequency band..... 100 Hz, 330 Hz,
 1 kHz, 3.3 kHz, 10 kHz, ± 7 dB
 Hum and Noise (DIN, continuous Power/50 mW)
 PHONO 68 dB/60 dB
 Total Harmonic Distortion
 (40 Hz to 20,000 Hz, 15 W, 8 ohms)** No more than 0.2%

Tape Deck Section

Systems..... 4 track, 2-channel stereo
 Heads Recording/playback head x 1
 Playback head x 1
 Erasing head x 1
 Motor..... DC servo 2 speed motor x 2
 Wow and Flutter..... No more than 0.09% (WRMS)
 Fast Winding Time Approximately 95 seconds
 (C-60 tape)

Frequency Response (-20 dB recording):
 Normal tape 35 Hz to 14,000 Hz ± 6 dB
 CrO₂ tape 35 Hz to 15,000 Hz ± 6 dB
 Signal-to-noise ratio
 Dolby NR OFF..... 56 dB
 Noise Reduction Effect
 Dolby B type NR ON More than 10 dB (at 5 kHz)

Furnished Parts

Operating Instructions 1
 Remote control unit 1
 Dry cell batteries 2

Miscellaneous

Power requirements
 U.K. model a.c. 240 Volts ~, 50/60 Hz
 Other destination models
 AC 110/120 - 127/220/240 V (switchable) 50/60 Hz
 Power Consumption 185 W
 Dimensions 360 (W) x 271 (H) x 334 (D) mm
 14-3/16 (W) x 13-1/8 (H) x 10-11/16 (D) in
 Weight (without package) 7.9 kg (17 lb 7 oz)

Accessories

EP Adaptor..... 1

** Specifications and design subject to possible modification without notice due to improvement.*

*** Measured By Audio Spectrum Analyser.*

2. P.C.BOARDS LOCATION

A

B

C

D

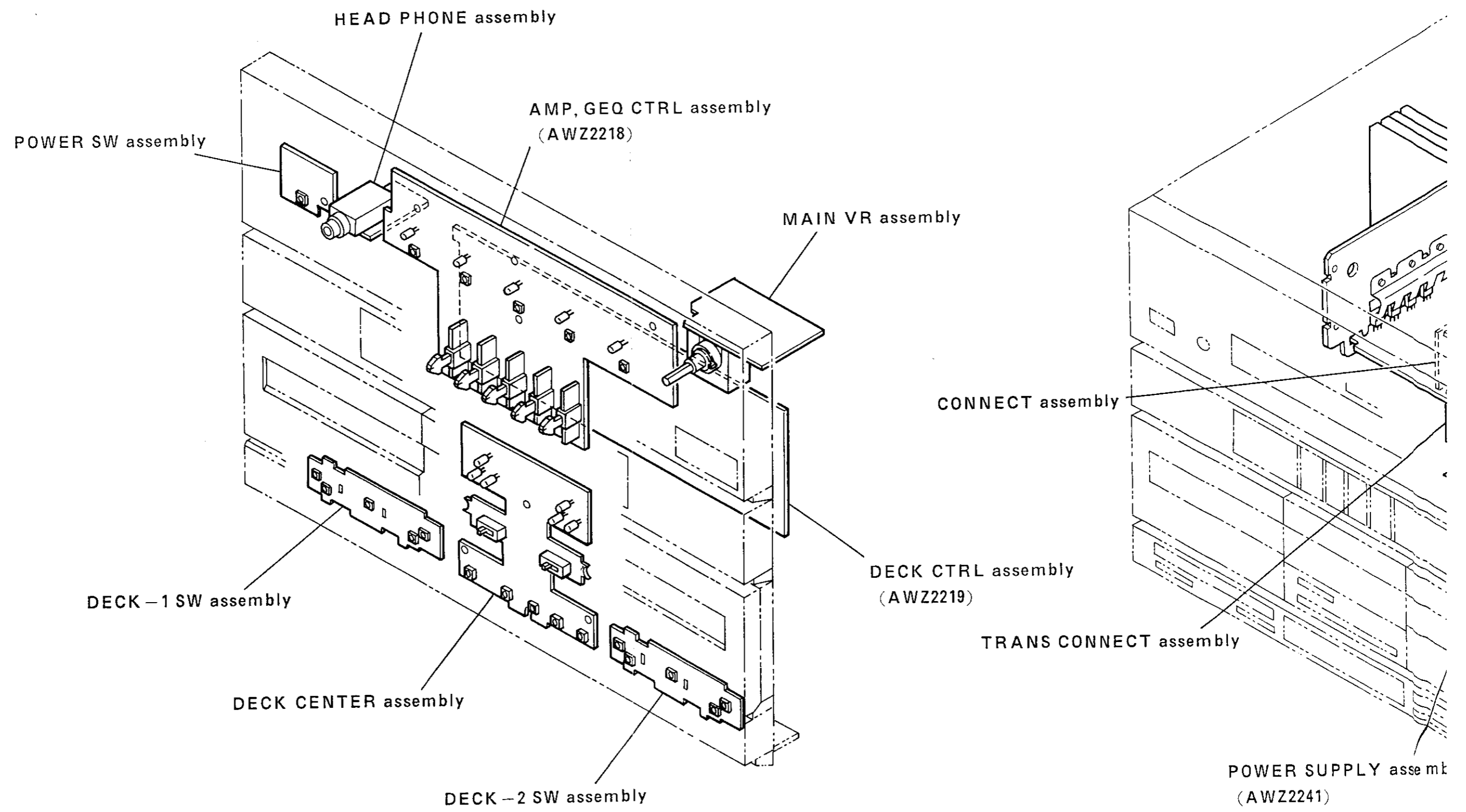

4

5

6

7

8

9

A

B

C

D

SEQ CTRL assembly
(2218)

MAIN VR assembly

DECK CTRL assembly
(AWZ2219)

CONNECT assembly

TRANS CONNECT assembly

POWER SUPPLY assembly
(AWZ2241)

AF assembly
(AWZ2217)

FUNCTION assembly

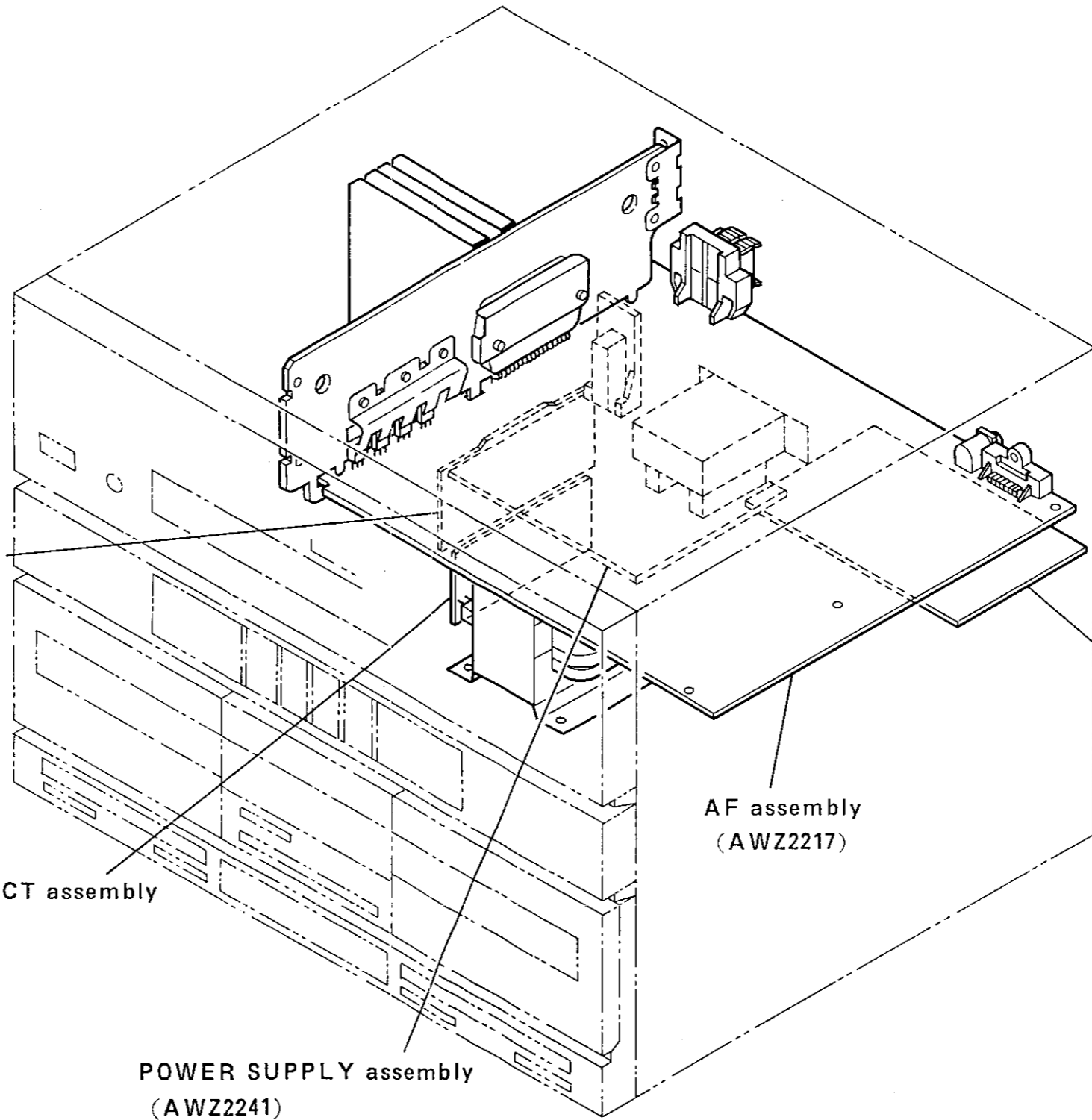
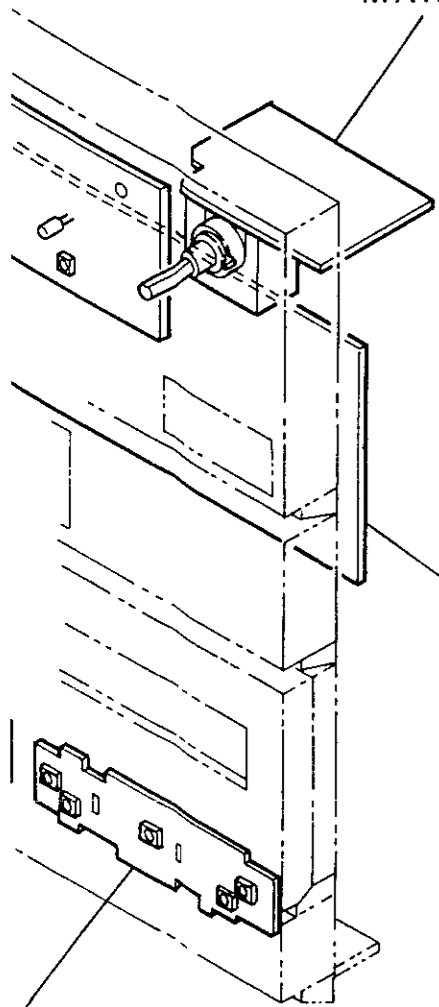

4

5

6

7

8

9

5

3. EXPLODED VIEWS, PAKING AND PARTS LIST

3.1 PARTS LIST OF MAIN BODY SECTION, FRONT PANEL SECTION AND PACKING

NOTES:

- Parts without part number cannot be supplied.
- The Δ mark found on some component parts indicates the importance of the safety factor of the part. Therefore, when replacing, be sure to use parts of identical designation.
- Parts marked by "●" are not always kept in stock. Their delivery time may be longer than usual or they may be unavailable.

Mark No.	Part No.	Description	Mark No.	Part No.	Description
Δ 1	ATS1179	POWER TRANSFORMER	51		FUNCTION ASSY
Δ 2	AEK-507	FUSE FU2003(T800MA)	52		POWER SW ASSY
Δ 3	AEK-509	FUSE FU2001(T1.25A)	53		DECK-1 SW ASSY
Δ 4	AEK-509	FUSE FU2004(T1.25A)	54		DECK-2 SW ASSY
Δ 5	AEK-509	FUSE FU2005(T1.25A)	55		
Δ 6	ADG-063	AC POWER CORD	56		HEAD PHONE ASSY
7	AEC-847	LEG ASS'Y	57		TRANSE CONNECT ASSY
8	ABH1050	SPRING	58	AWZ2217	AF ASSY
9	ABH1051	SPRING	59		MAIN VR ASSY
10	AMR1656	EJECT LEVER-1	60		
11	AMR1657	EJECT LEVER-2	61	AWZ2241	POWER SUPPLY ASSY
12	AXA1005	DAMPER ASSEMBLY	62		CONNECT ASSY
13	ABA-283	SCREW (STEEL)	63		TERMINAL SCREW
14	ABA1084	SCREW	64		EARTH LEAD
15	BBZ26P080FMC	SCREW	65		MECHA UNIT
16	BBZ30P060FMC	SCREW	66		MECHA UNIT
17	BBZ30P080FCU	SCREW	67		CHASSIS
18	BBZ30P080FZK	SCREW	68		REAR PANEL
19	BPZ26P080FMC	SCREW	69		HEAT SINK
20	NK90FUC	NUT	70		PLATE
21	VBZ30P160FMC	SCREW	71		PLATE
22	VPZ30P080FZK	SCREW	72		PLATE A
23	VTZ30P100FZK	SCREW	73		PLATE B
24	AMB1437	FRONT PANEL ASSEMBLY	74		PLATE
25	AAK1629	INDICATOR LENS	75		SHIELD PLATE
26	AAK1660	DECORATIVE PLATE	76		KEEP PLATE
27	AAK1661	DECORATIVE PLATE	77		
28	AAK1662	DECORATIVE PLATE(DOOR)	78		NYLON REVET
29	AAK1664	DECORATIVE PLATE(DOOR)	79		BINDER
30	AAB1089	KNOB(VOLUME)	80		
31	AAD1515	BUTTON(ASES)	81		SPACER
32	AAD1516	BUTTON(FUNCTION)	82		
33	AAD1520	BUTTON(POWER)	83		"AAA" DRY CELL
34	AAD1525	BUTTON(PLAY)	84		WARRANTY CARD
35	AAD1528	BUTTON(EJECT)	85		SHEET
36	AAD1529	BUTTON(REC)	86		SHEET
37	AAE1103	SLIDE KNOB			
38	AAN1120	CASSETTE DOOR			
39	AAN1121	CASSETTE DOOR			
40	ARB1154	OPERATING INSTRUCTION			
41	AXD1088	REMOTE CONTROL UNIT			
42	ARM1003	CAUTION CARD			
43	AHA1232	PAD(L)			
44	AHA1233	PAD(R)			
45	AHD1582	PAKING CASE			
46	ANE1180	BONNET			
47					
48		DECK CENTER ASSY			
49	AWZ2218	AMP GEQ CTRL ASSY			
50	AWZ2219	DECK CTRL ASSY			

3.2 MAIN BODY SECTION

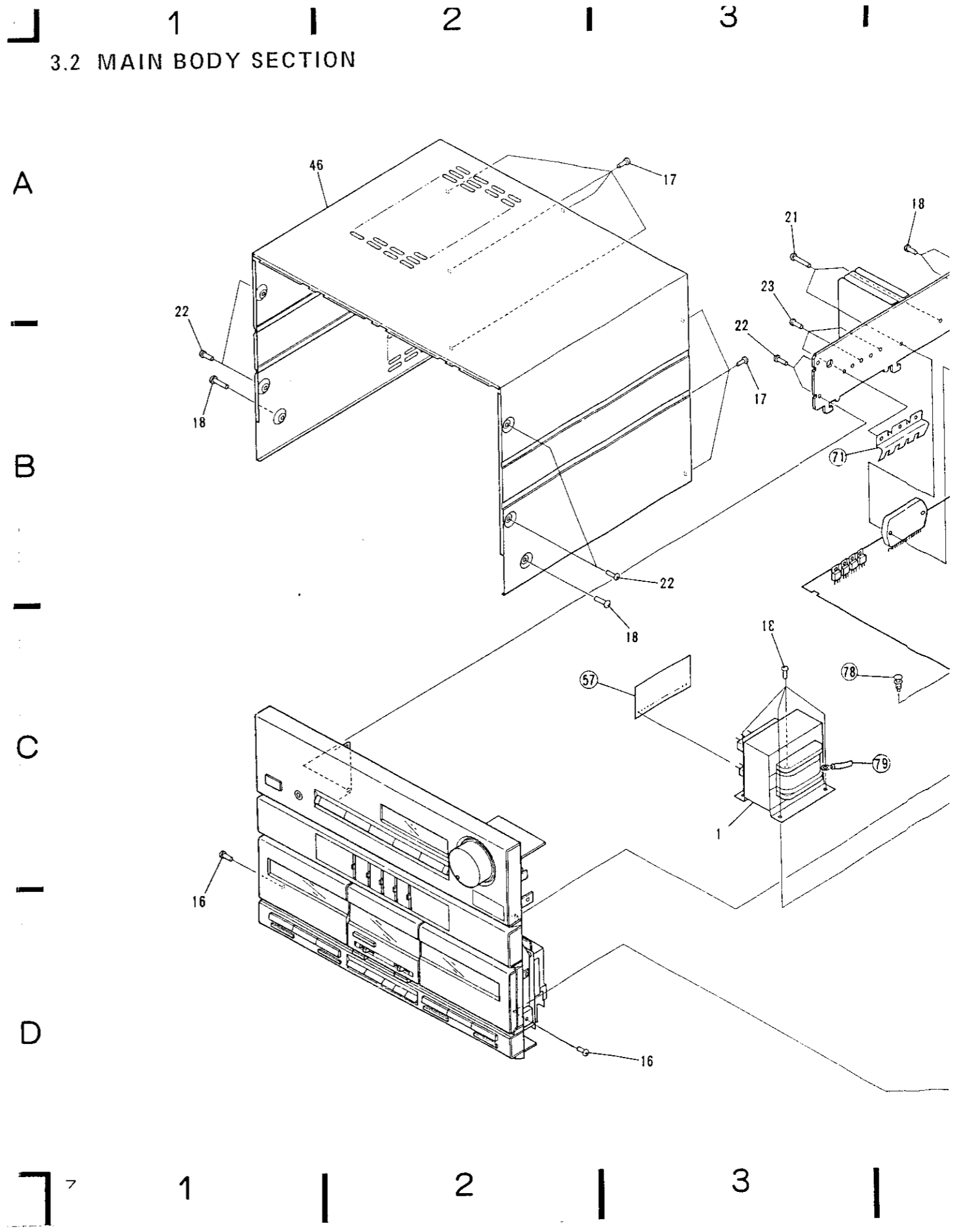

3.2 MAIN BODY SECTION

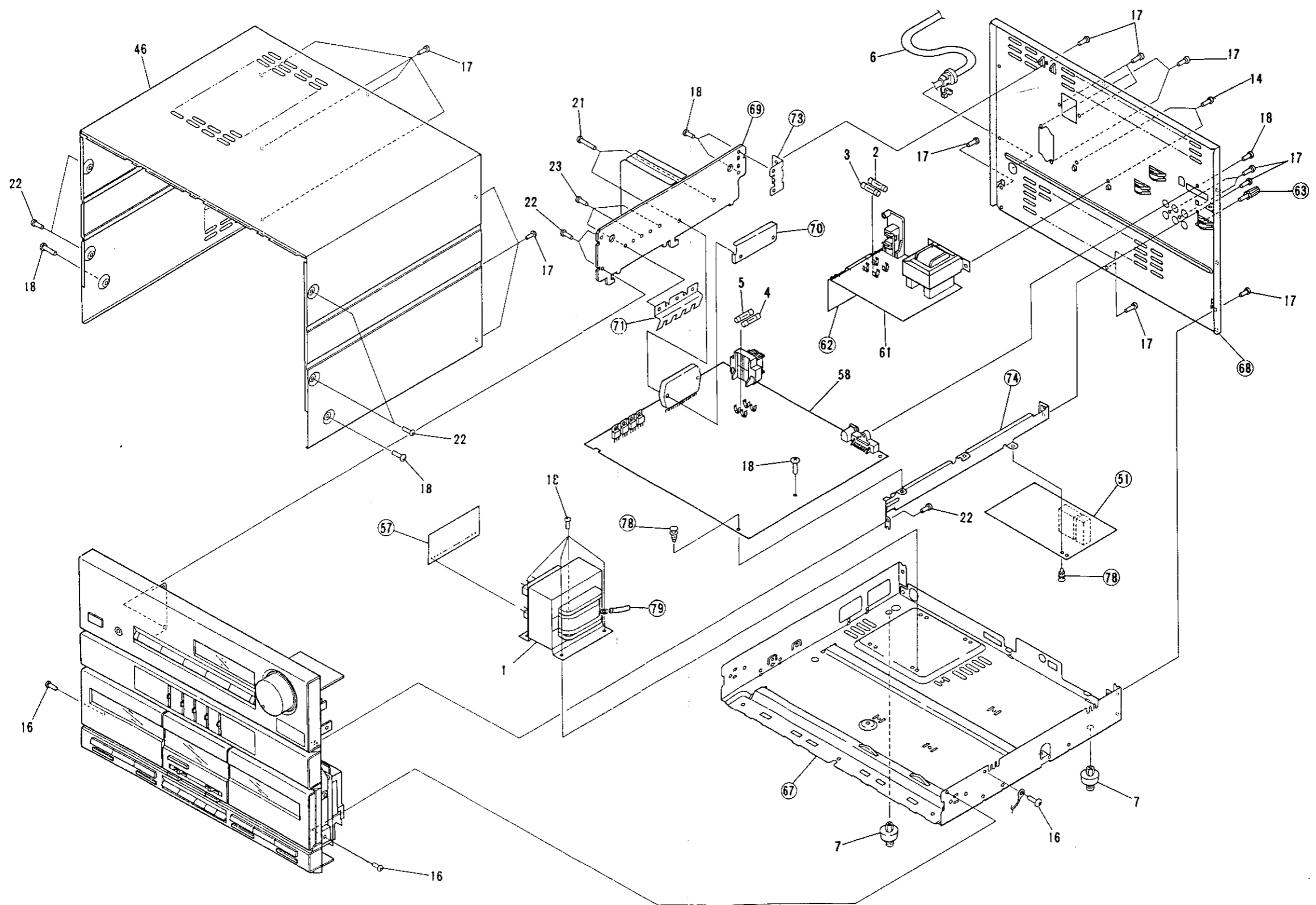

3.3 FRONT PANEL SECTION

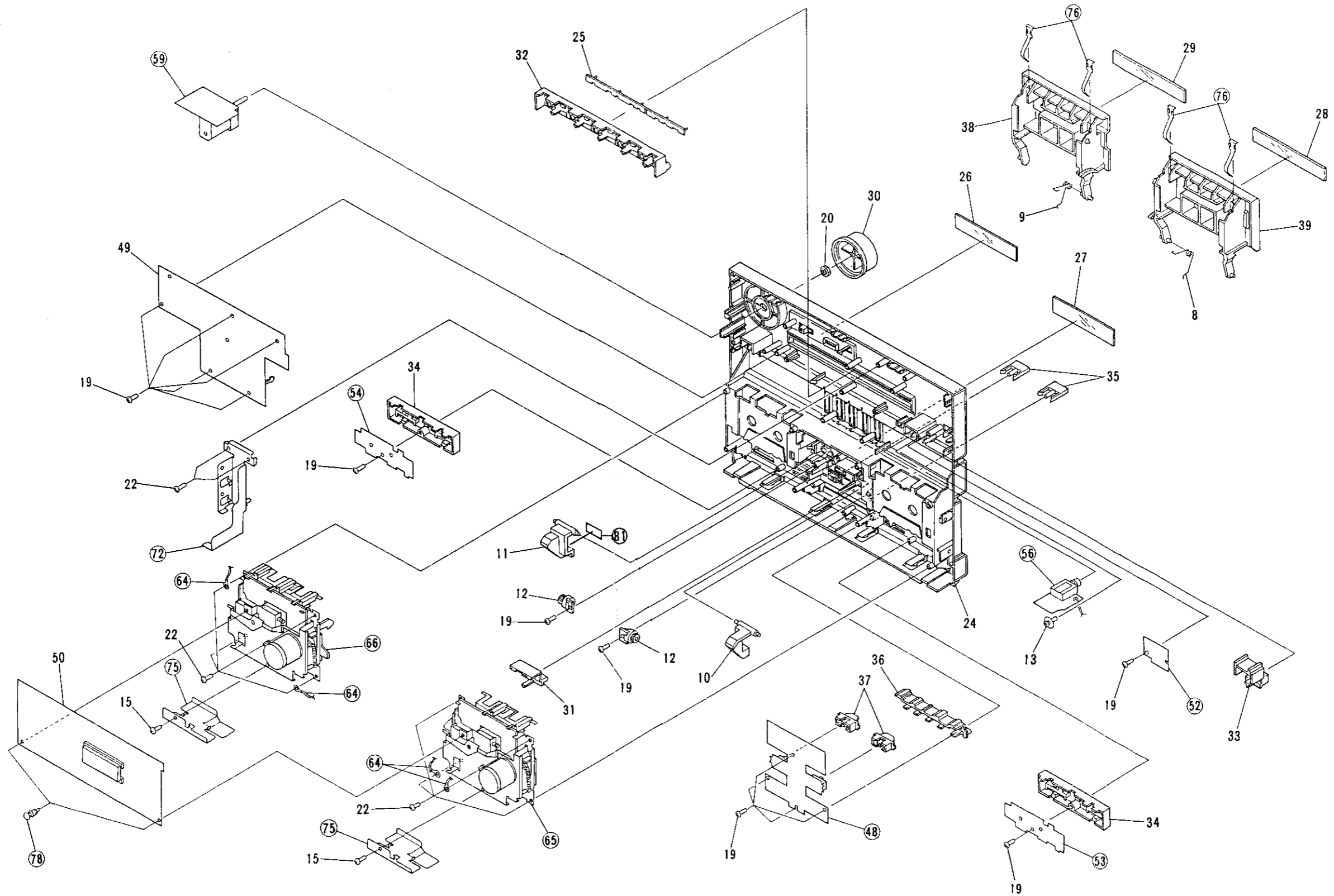

4

5

6

3.4 PACKING

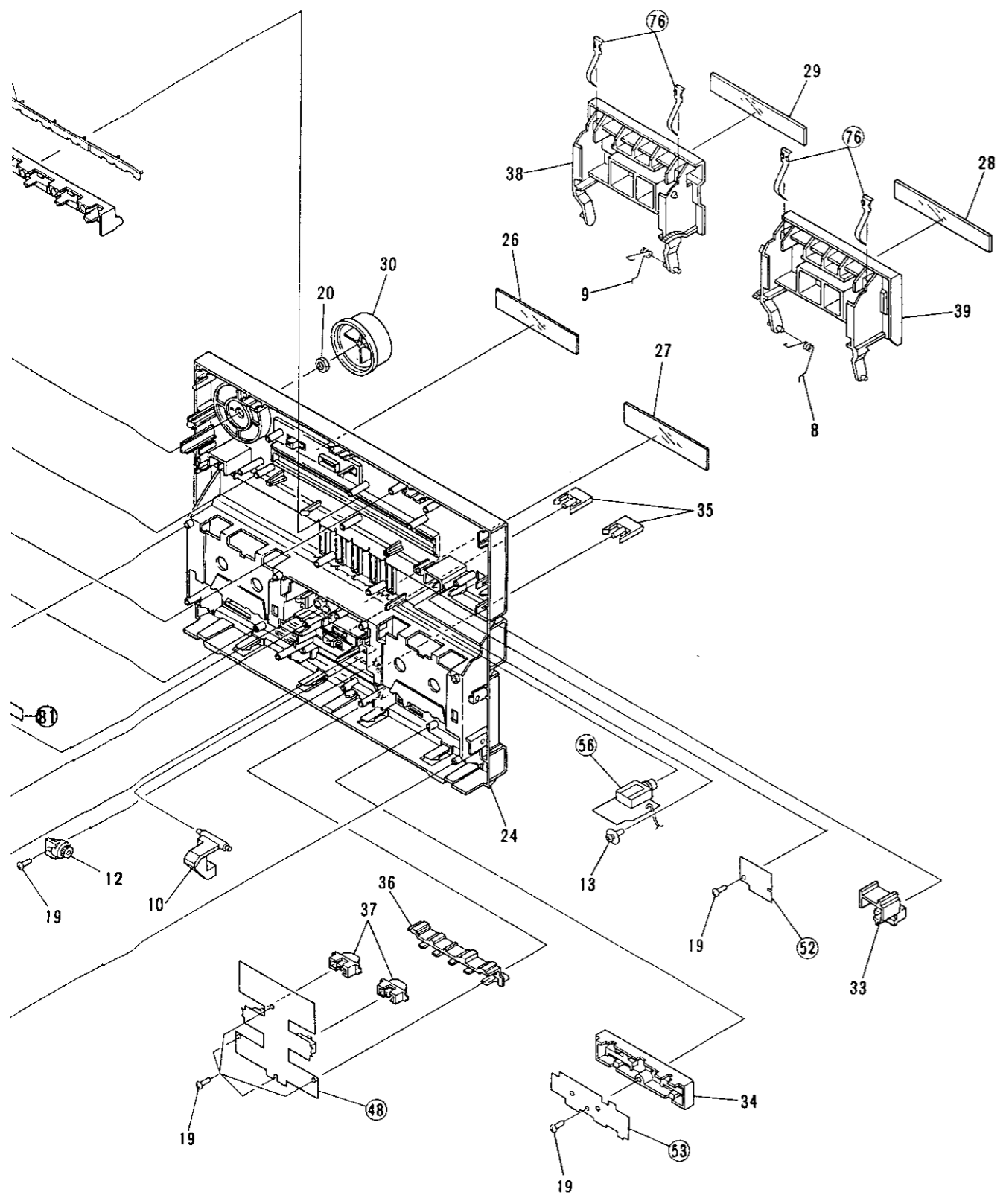

A

B

C

D

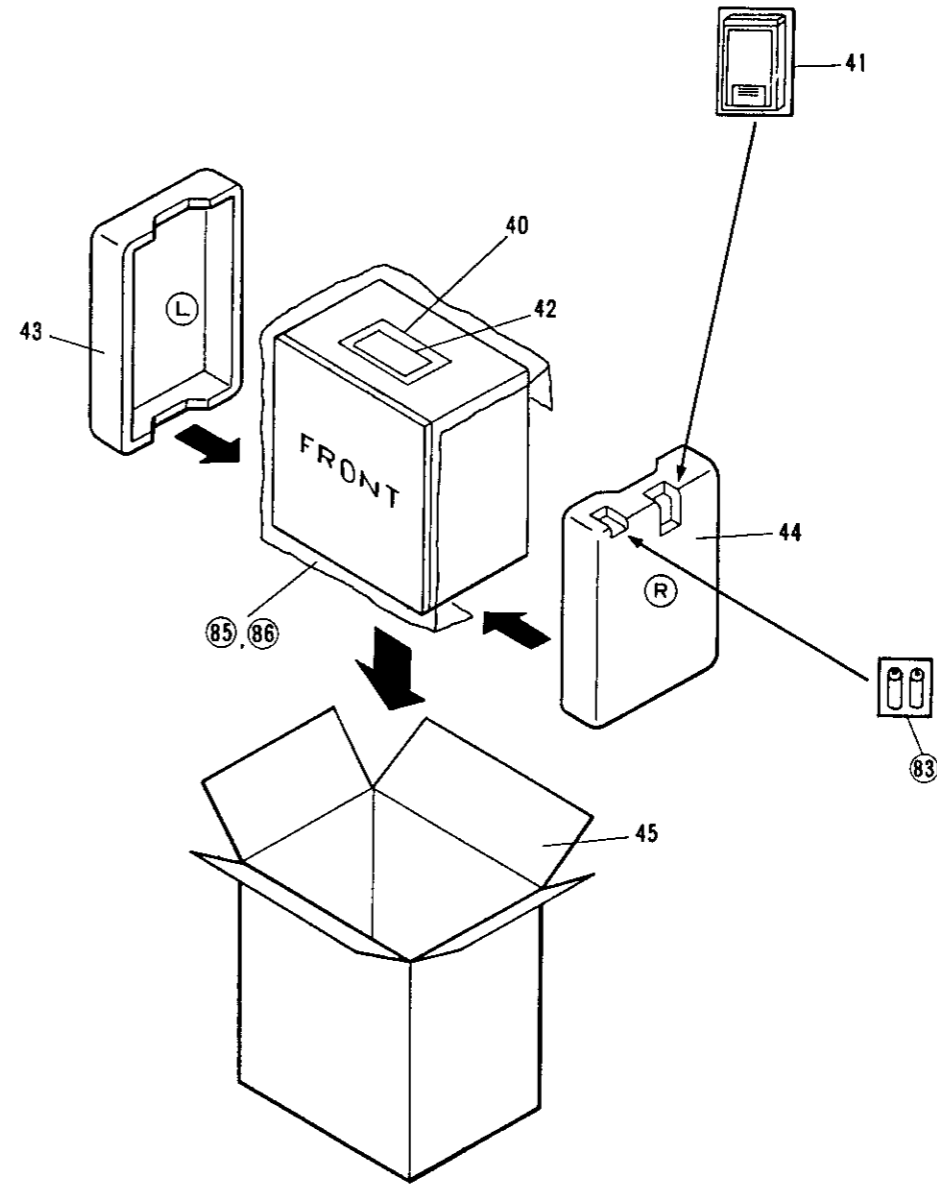

Parts list of Remote control Unit(AXD1088)

Mark	No.	Parts No.	Description
		AZN1856	Battery cover

4

5

6

10

3.5 MECHA UNIT 1

Mark	No.	Parts No.	Description	Mark	No.	Parts No.	Description
	1	AZE1018	Half IC		53	AZN1326	Head lever calking assembly
	2	AZX1019	Motor		54	AZN1327	FW assembly
	3	AZS1054	Leaf SW(MODE)		55		Head P.C.Board
	4	AZS1034	Leaf SW (HALF, CrO2)		56		Plate(FLYWHEEL)
	5	AZN1286	Drive arm assembly		57	AZN1328	Azimuth plate
	6	AZN1287	FW assembly A		58		SW arm
	7	AZN1288	Cam gear		59	AZN1356	Eject arm L
	8	AZN1289	Reel		60	AZN1357	Eject arm R
	9	AZN1290	FR arm		61	AZN1330	Head arm
	10	AZN1797	P arm L assembly		62	AZN1331	P Azimuth spring
	11	AZN1798	P arm R assembly		63	AZN1332	Cassette stopper
	12	AZN1293	Gear		64	AZN1333	Play trigger calking assembly
	13	AZN1294	H Gear		65	AZN1334	Head frame
	14	AZN1793	CUE arm		66	AZN1335	Cassette guide L
	15	AZB1079	Screw		67	AZN1336	Cassette guide R
	16	AZB1080	Screw		68	AZN1337	Cassette guide
	17	AZN1296	Collar C		69	AZN1338	Cam gear
	18	AZN1297	Motor pully		70	AZN1469	Head holder
	19	AZN1298	Belt		71	AZN1340	Head gear
	20	AZN1299	Spring		72	AZN1341	Eject arm
	21	AZN1300	FR lever spring		73	AZN1342	Select lever
	22	AZN1301	FWF spring		74	AZN1343	Brake
	23	AZN1302	FWR spring		75	AZN1344	Eject lever L
	24	AZN1303	Spring		76	AZN1345	Ratch lever R
	25	AZB1088	Collar		77	AZN1346	Metal
	26	AZN1467	Cable holder		78	AZN1347	Metal
	27	AZN1306	Spring		79	AZN1348	Cushion
	28	AZN1307	Spring		80	AZN1349	Trigger arm
	29	AZN1308	Spring		81	AZN1350	Plunger
	30	AZN1309	Spring		82	AZS1035	Bobbin
	31	AZN1310	Spring		83	AZN1351	Solenoid plate calking assembly
	32	AZN1311	Spring		84	AZP1022	P Head
	33	AZN1312	Spring		85	AZB1099	Screw
	34	AZN1313	Spring		86	AZN1352	Spring
	35	AZN1314	Spring		87	AZN1304	Spacer
	36	AZN1315	Spring		88	AZN1470	Tube
	37	AZB1081	Screw		89	AZB1100	Screw
	38	AZN1316	Nylon band		90	AZS1036	Bobbin
	39	AZN1835	P.C.Board		91	AZB1101	Screw
	40		Jumper wire		92	AZB1102	Spring washer
	41		Head lead		93	AZN1471	Head spring
	42		Lead wire		94	AZN1833	Capstan holder
	43		Lead wire		95	AZN1834	Capstan holder
	44	AZN1468	Tube		200	AZB1084	Nut
	45		Mecha P.C.Board calking assembly		201	AZB1085	E ring
	46	AZN1319	R Reel assembly		202	AZB1086	D Screw
	47	AZN1320	F Reel assembly		203	AZB1121	P Washer
	48	AZN1321	Reverse arm calking assembly		204	AZB1087	N Washer
	49		FR lever calking assembly		205	AZB1089	U Screw
	50	AZN1795	PLAY lever calking assembly		206	AZB1090	P Washer
	51	AZN1324	Gear arm R calking assembly		207	AZB1091	Oil cut
	52	AZN1325	Gear arm L calking assembly		208	AZB1092	Oil cut
					209	AZB1093	P Washer
					210	AZB1094	P Washer

Mark	No.	Parts No.	Description
	211	AZB1095	D Screw
	212	
	213	AZB1097	P Washer
	214	AZB1098	M Washer
	215	AZB1105	P Screw
	216	AZB1106	D Screw
	217	AZB1107	P Washer
	218	AZB1164	P screw
	300	AZX1020	Motor assembly
	301	AZP1023	Head frame assembly
	302	AZB1104	Screw

A

B

C

D

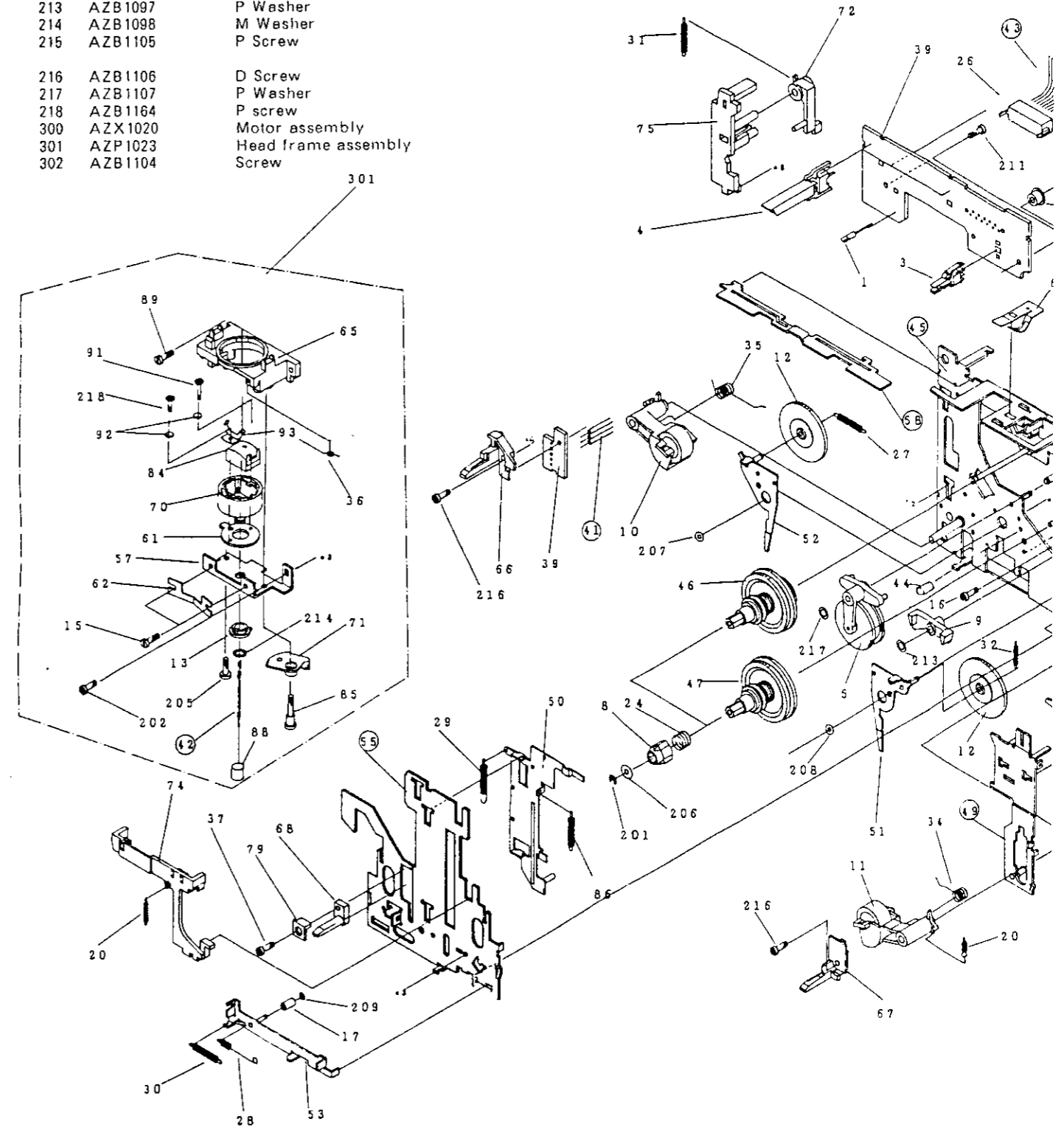

1

2

3

4

5

6

Mark	No.	Parts No.	Description
	211	AZB1095	D Screw
	212	
	213	AZB1097	P Washer
	214	AZB1098	M Washer
	215	AZB1105	P Screw
	216	AZB1106	D Screw
	217	AZB1107	P Washer
	218	AZB1164	P screw
	300	AZX1020	Motor assembly
	301	AZP1023	Head frame assembly
	302	AZB1104	Screw

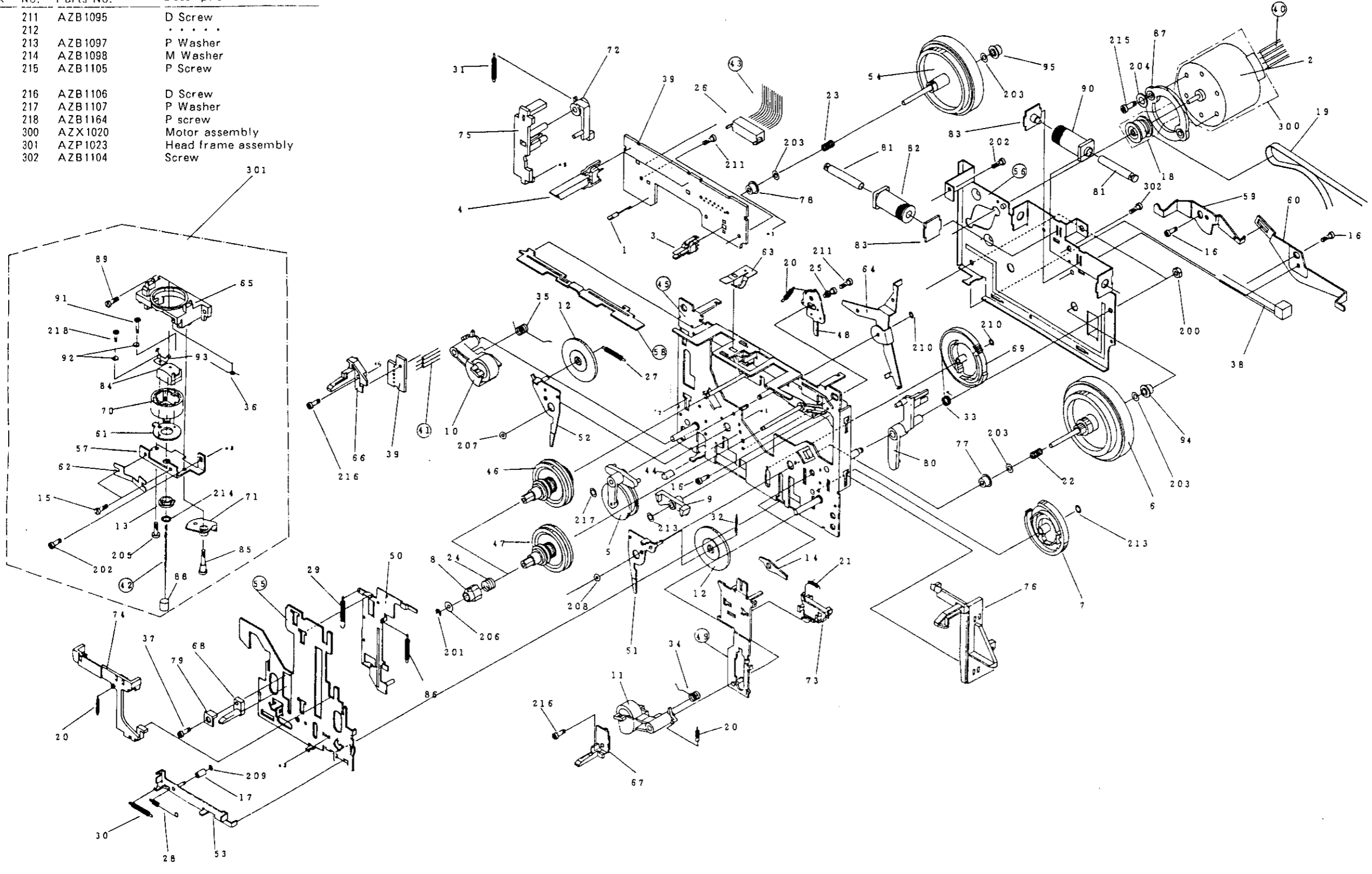

A

A

B

B

C

C

D

D

1

2

3

4

5

6

3.6 MECHA UNIT 2

Mark	No.	Parts No.	Description
1		AZE1018	Half IC
2		AZX1019	Motor
3		AZS1054	Leaf SW(MODE)
4		AZS1034	Leaf SW (ARF,HALF, CrO2)
5		AZN1286	Drive arm assembly
6		AZN1287	FW assembly A
7		AZN1288	Cam gear
8		AZN1289	Reel
9		AZN1290	FR arm
10		AZN1797	P arm L assembly
11		AZN1798	P arm R assembly
12		AZN1293	Gear
13		AZN1294	H Gear
14		AZN1793	CUE arm
15		AZB1079	Screw
16		AZB1080	Screw
17		AZB1296	Collar C
18		AZN1297	Motor pully
19		AZN1298	Belt
20		AZN1299	Spring
21		AZN1300	FR lever spring
22		AZN1301	FWF spring
23		AZN1302	FWR spring
24		AZN1303	Spring
25		AZB1088	Collar
26		AZN1305	Cable holder
27		AZN1306	Spring
28		AZN1307	Spring
29		AZN1308	Spring
30		AZN1309	Spring
31		AZN1310	Spring
32		AZN1311	Spring
33		AZN1312	Spring
34		AZN1313	Spring
35		AZN1314	Spring
36		AZN1315	Spring
37		AZB1081	Screw
38		AZN1316	Nylon band
39		AZN1836	P.C.Board
40			Jumper wire
41			Head lead
42			Lead wire
43			Lead wire
44		AZN1468	Tube
45			Mecha P.C.Board calking assembly
46		AZN1319	R Reel assembly
47		AZN1320	F Reel assembly
48		AZN1321	Reverse arm calking assembly
49			FR lever calking assembly
50		AZN1795	PLAY lever calking assembly
51		AZN1324	Gear arm R calking assembly
52		AZN1325	Gear arm L calking assembly

Mark	No.	Parts No.	Description
53		AZN1326	Head lever calking assembly
54		AZN1327	FW assembly
55			Head P.C.Board
56			Plate(FLYWHEEL)
57		AZN1328	Azimuth plate
58			SW arm
59		
60		
61		AZN1330	Head arm
62		AZN1331	Azimuth spring
63		AZN1332	Cassette stopper
64		AZN1333	Play trigger calking assembly
65		AZN1334	Head frame
66		AZN1335	Cassette guide L
67		AZN1336	Cassette guide R
68		AZN1337	Cassette guide
69		AZN1338	Cam gear
70		AZN1469	Head holder
71		AZN1340	Head gear
72		AZN1341	Eject arm
73		AZN1342	Select lever
74		AZN1343	Brake
75		
76		AZN1353	Ratch lever R
77		AZN1346	Metal
78		AZN1347	Metal
79		AZN1348	Cushion
80		AZN1349	Trigger arm
81		AZN1350	Plunger
82		AZS1035	Bobbin
83		AZN1351	Solenoid plate calking assembly
84		AZP1014	R/P/E Head
85		AZB1099	Screw
86		AZN1352	Spring
87		AZN1304	Spacer
88		AZN1470	Tube
89		AZB1100	Screw
90		AZS1036	Bobbin
91		AZB1101	Screw
92		AZB1102	Spring washer
93		
94		AZN1833	Capstan holder
95		AZN1834	Capstan holder
200		AZB1084	Nut
201		AZB1085	E ring
202		AZB1086	D Screw
203		AZB1121	P Washer
204		AZB1087	N Washer
205		AZB1089	U Screw
206		AZB1090	P Washer
207		AZB1091	Oil cut
208		AZB1092	Oil cut
209		AZB1093	P Washer
210		AZB1094	P Washer

Mark	No.	Parts No.	Description
211		AZB1095	D Screw
212		
213		AZB1097	P Washer
214		AZB1098	M Washer
215		AZB1105	P Screw
216		AZB1106	D Screw
217		AZB1107	P Washer
218		
300		AZX1020	Motor assembly
301		AZP1016	Head frame assembly
302		AZB1104	Screw

A
B
C
D

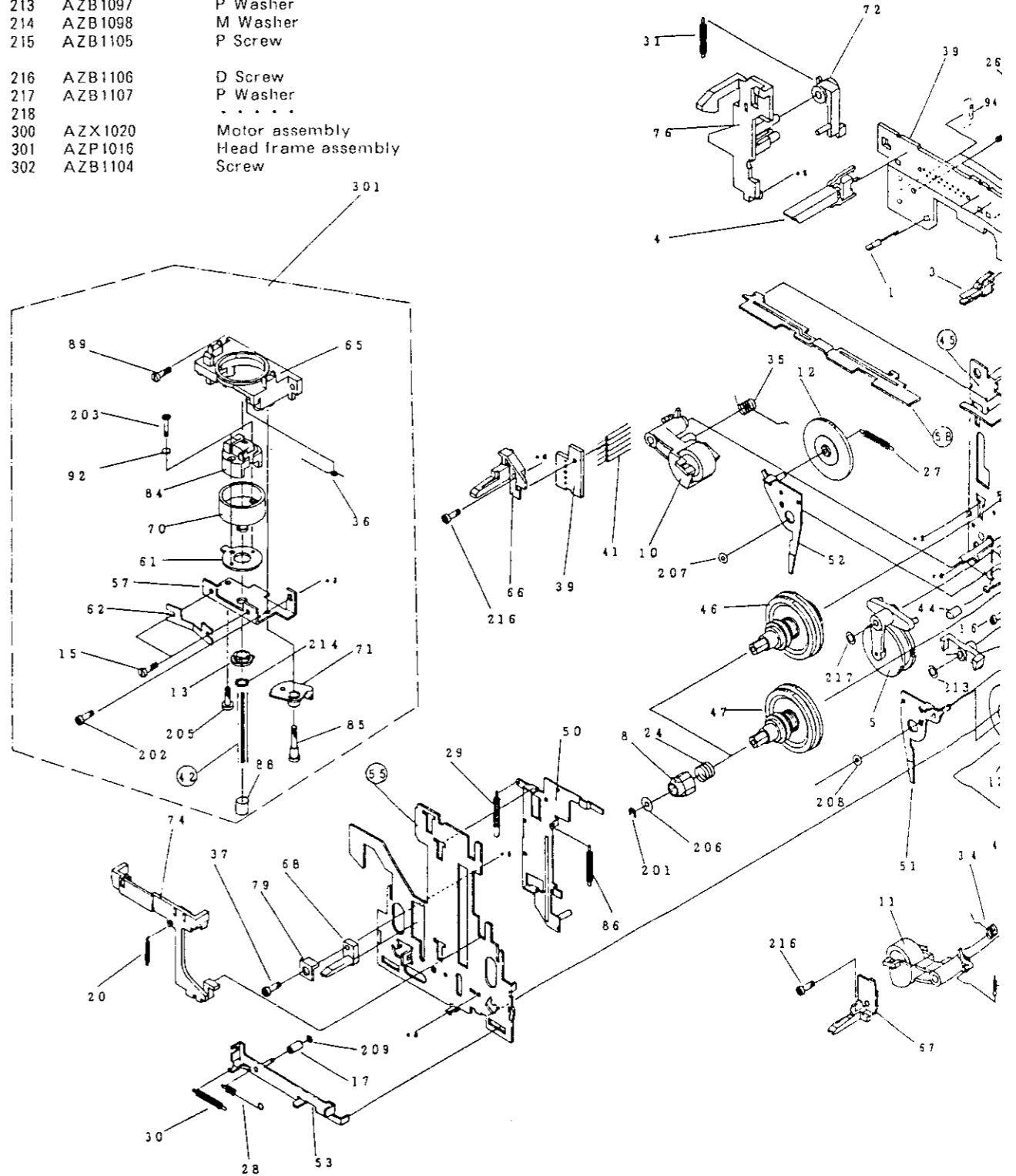

Mark	No.	Parts No.	Description
	211	AZB1095	D Screw
	212	
	213	AZB1097	P Washer
	214	AZB1098	M Washer
	215	AZB1105	P Screw
	216	AZB1106	D Screw
	217	AZB1107	P Washer
	218	
	300	AZX1020	Motor assembly
	301	AZP1016	Head frame assembly
	302	AZB1104	Screw

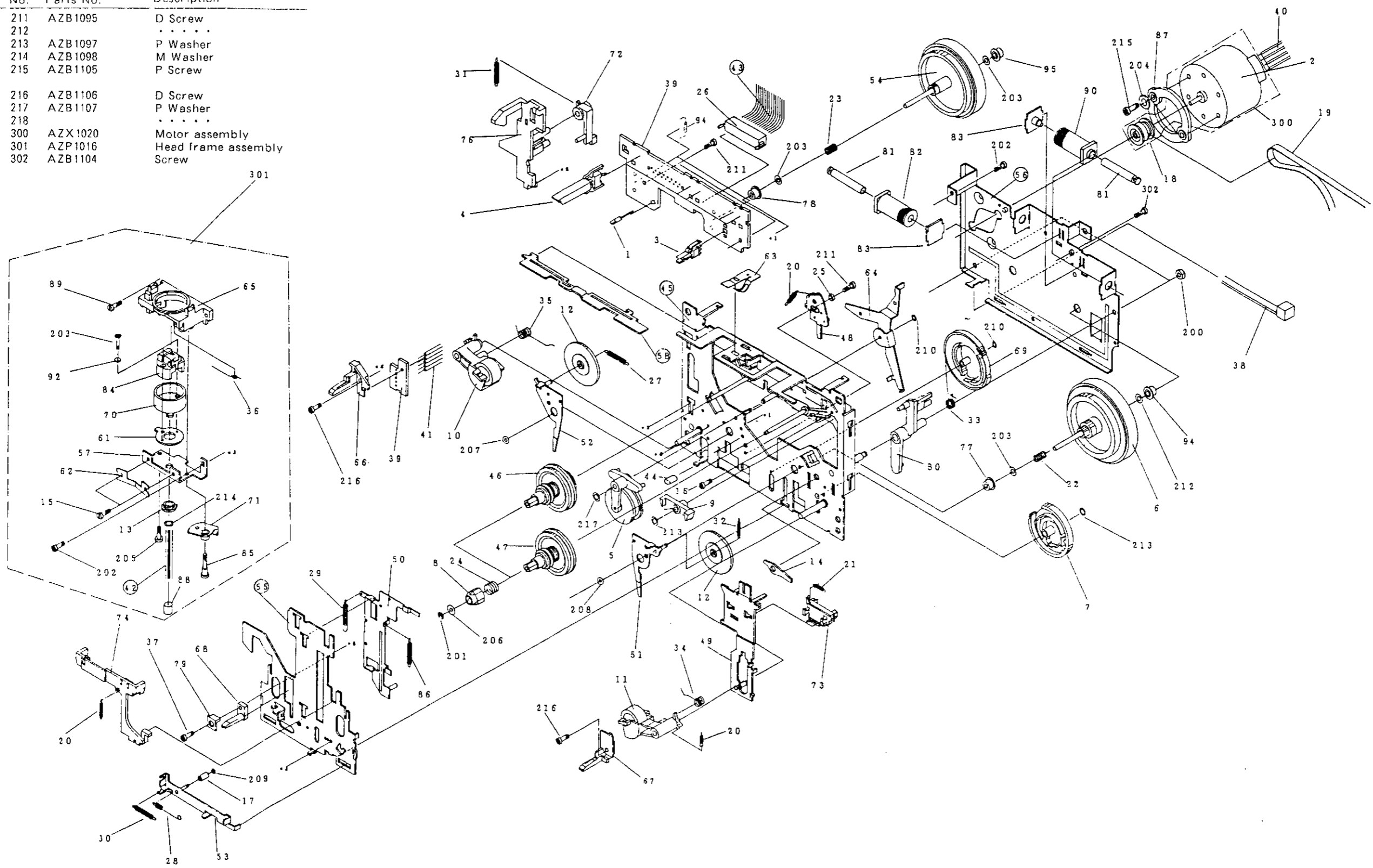

4. SCHEMATIC DIAGRAM AND P.C.BOARD CONNECTION DIAGRAM

4.1 OVER ALL SCHEMATIC DIAGRAM

A

B

C

D

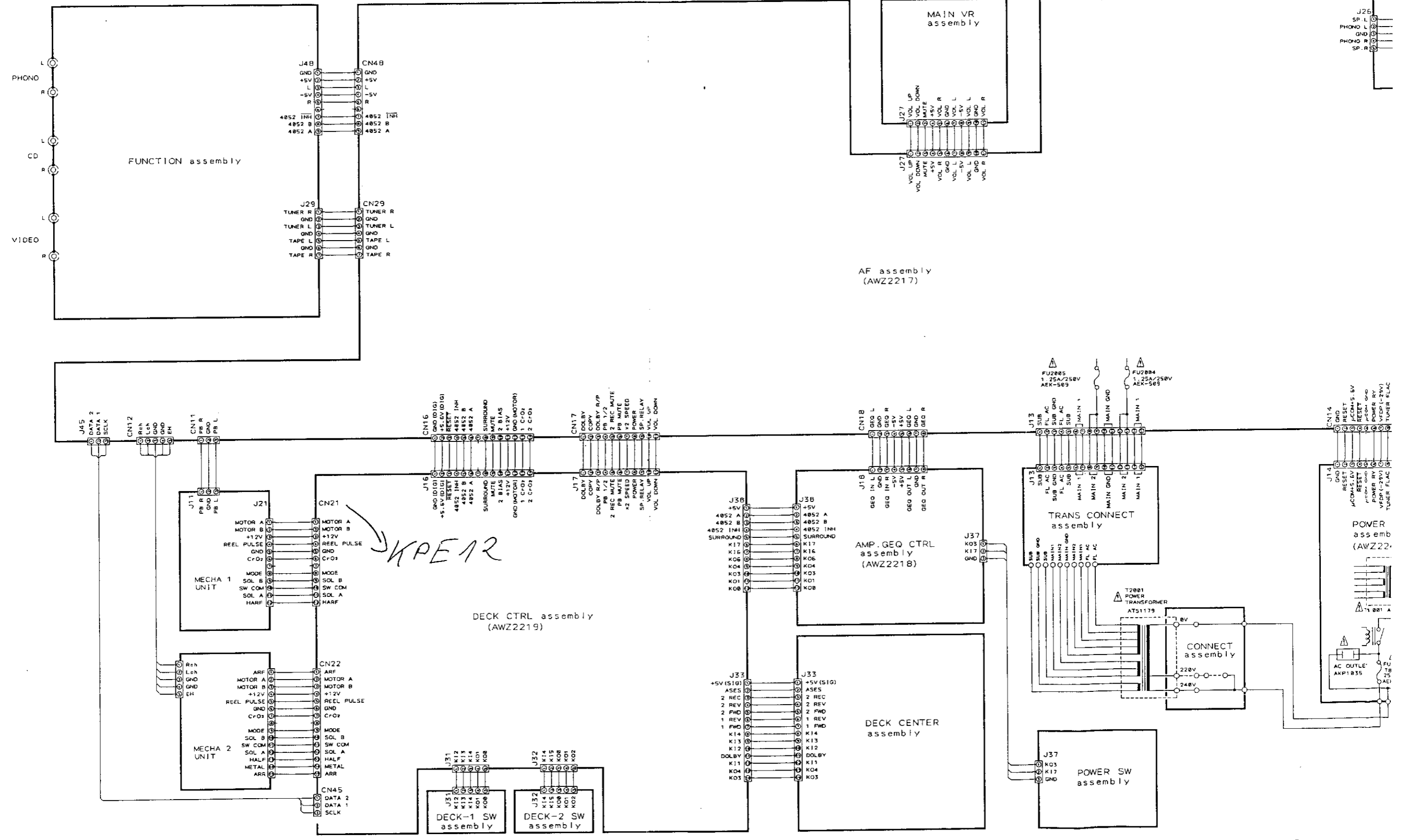

KPE 12

ION DIAGRAM

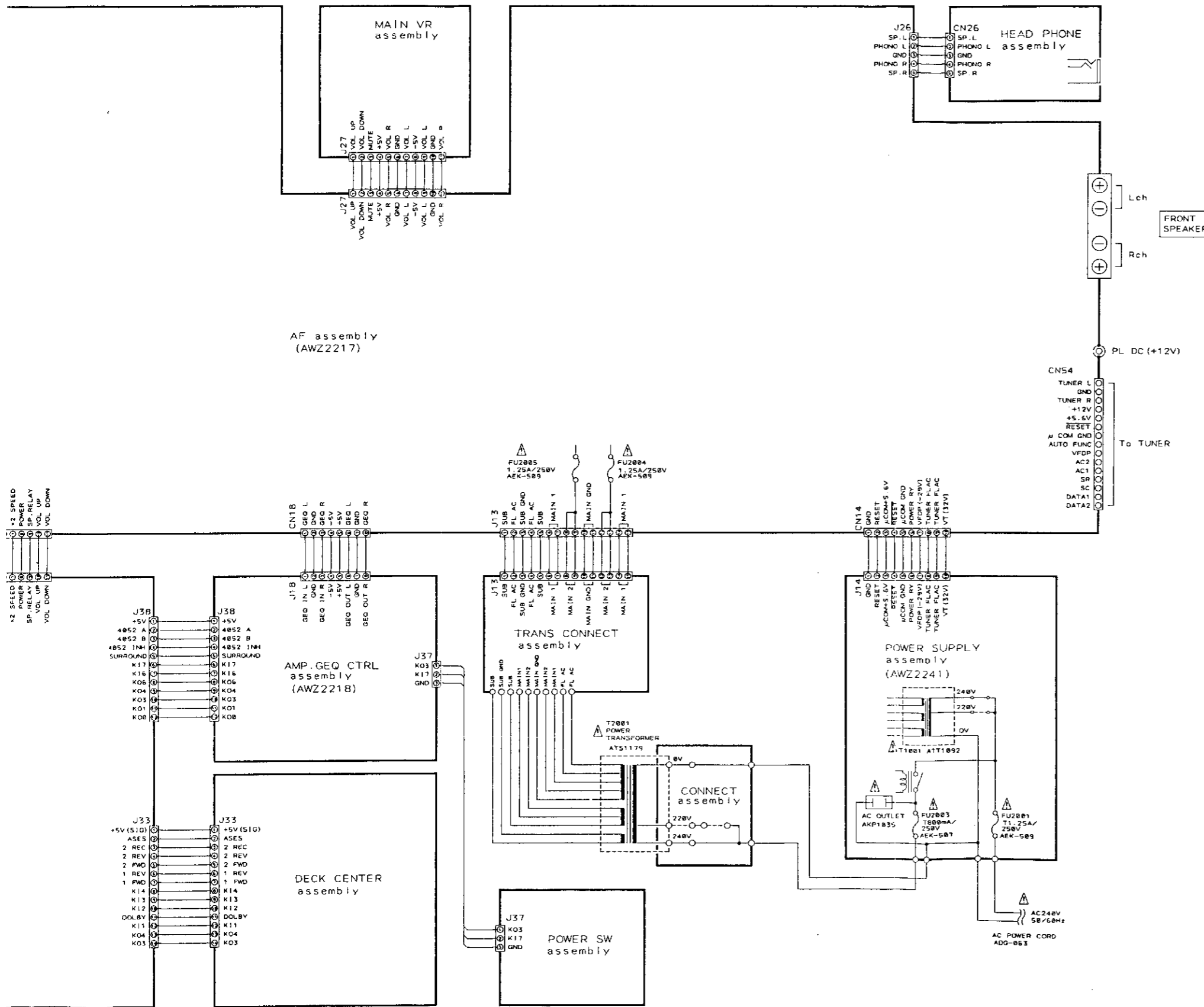

1. RESISTORS:
Indicated in Ω, ¼W, ½W, ±5% tolerance unless otherwise noted k:kΩ, M:MΩ, (F): ±1%, (G): ±2%, (K): ±10% (M): ±20% tolerance
2. CAPACITORS:
Indicated in capacity (μF)/voltage (V) unless otherwise noted p:pF
Indication without voltage is 50V except electrolytic capacitor.
3. VOLTAGE, CURRENT:
 - ⊖: Signal voltage at (33W + 33W 8Ω)output (1kHz)
 - ⊖: DC voltage (V) at no input signal
 - Value in () is DC voltage at rated power.
 - ⊖ mA: DC current at no input signal
4. OTHERS:
 - ➔: Signal route.
 - ⊙: Adjusting point.

The ⚠ mark found on some component parts indicates the importance of the safety factor of the part. Therefore, when replacing, be sure to use parts of identical designation.
* marked capacitors and resistors have parts numbers.

This is the basic schematic diagram, but the actual circuit may vary due to improvements in design.

- SWITCHES:
- AMP,GEQ CTRL assembly (AWZ2218)
S701-S705 TACT SW
 - DECK-1 SW assembly
S811-S815 TACT SW
 - DECK-2 SW assembly
S821-S825 TACT SW
 - DECK CENTER assembly
S847 DOLBY OFF-ON
S848 REVERSE MODE
 - S841-S846 TACT SW
 - POWER SW assembly
S707 POWER

The underline indicates the switch position

A

B

C

D

15

11

10

9

8

15

11

10

9

8

7

A

B

C

D

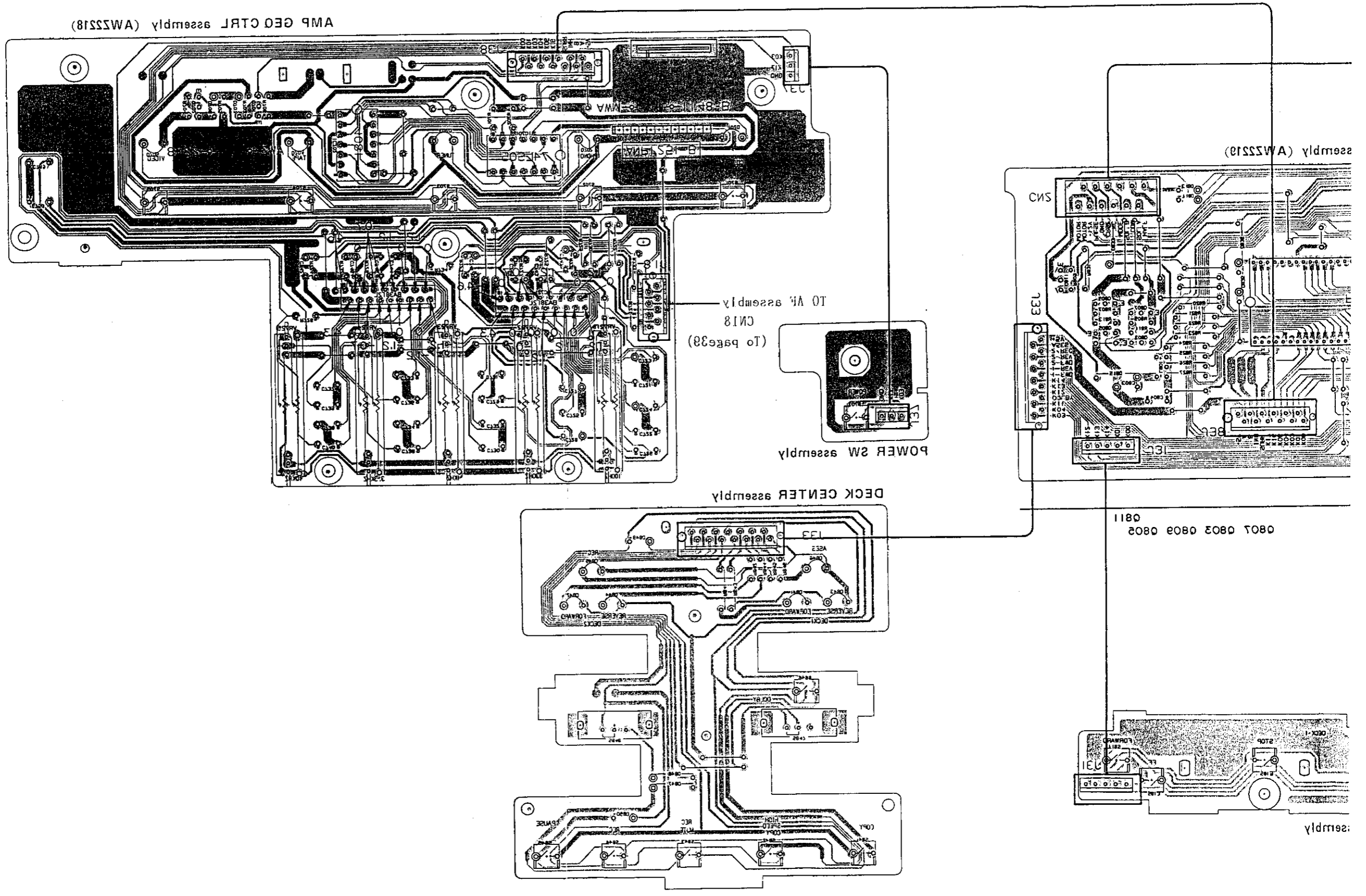

1 2 3 4 5

NOTE:
This picture shows the foil side of the printed circuit.

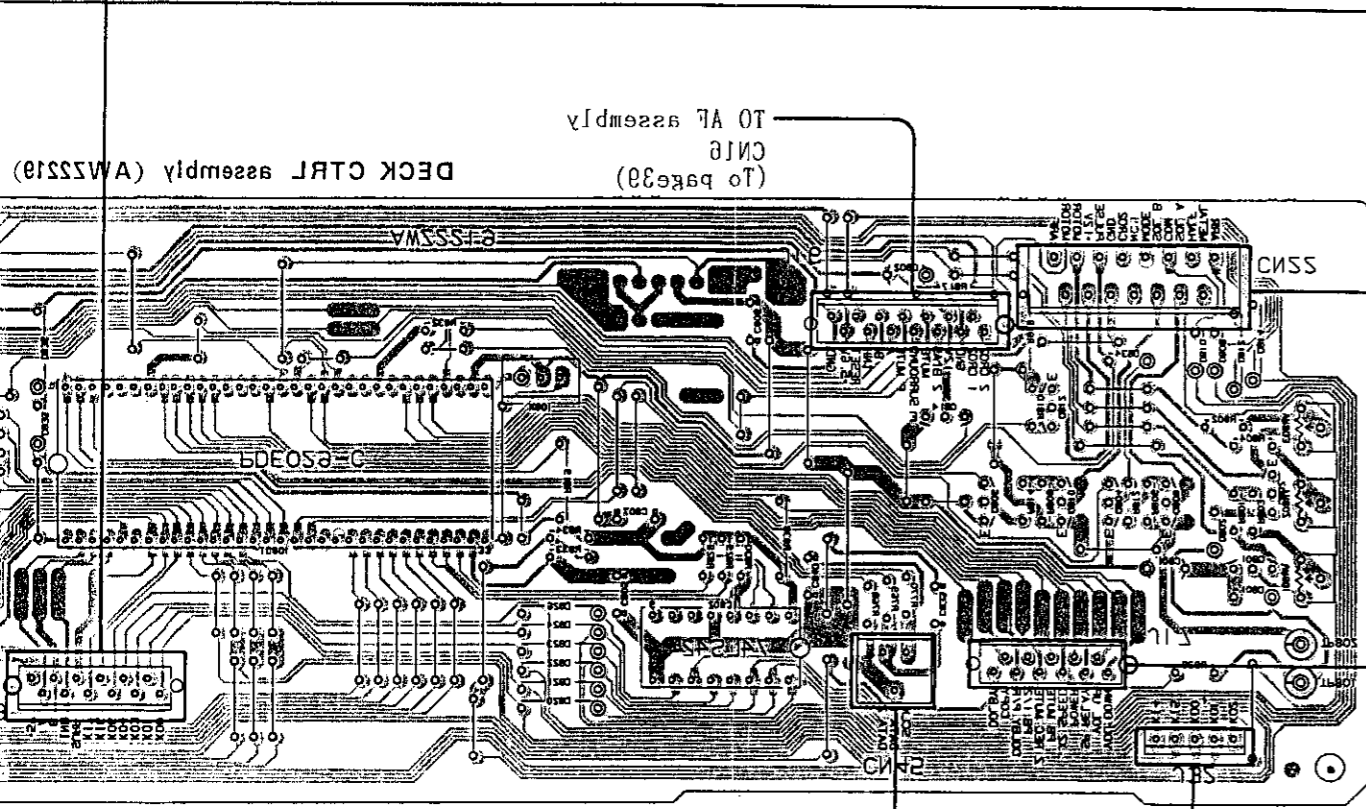

0801 0804 0808 0810 0808 0805 0801
0808 0815 0814 0818 0818
VRB01-VRB03

TO AF assembly
(To page 3)
CN18

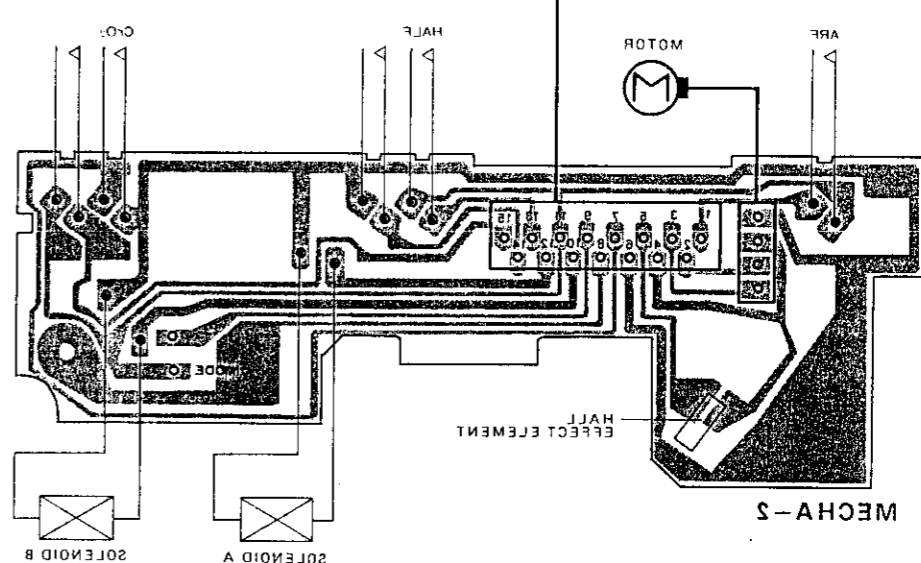
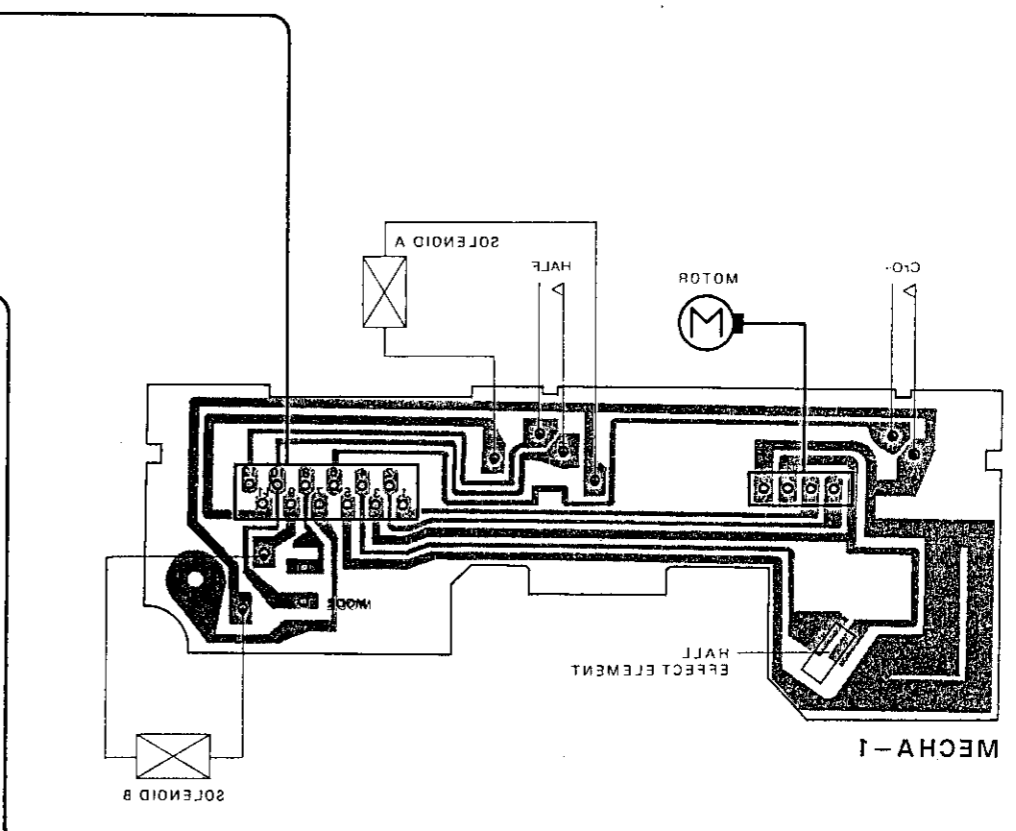
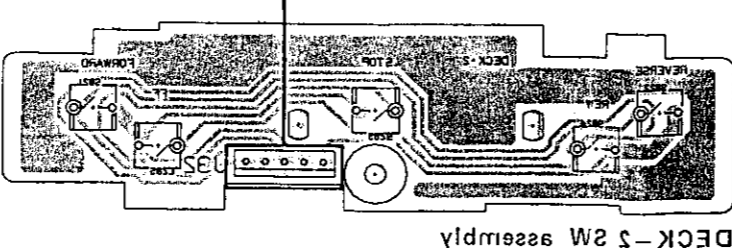
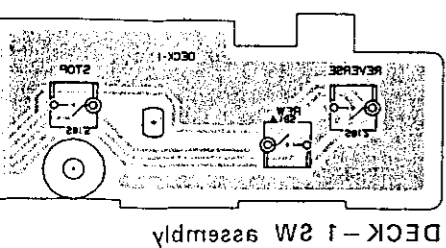

A
B
C
D

4.2 AMP, GEO CTRL (AWZ2218), DECK - 1SW, DECK - 2SW, DECK CTRL (AWZ2219), DECK CENTER assembly, MECHA - 1 and MECHA - 2 UNIT

A

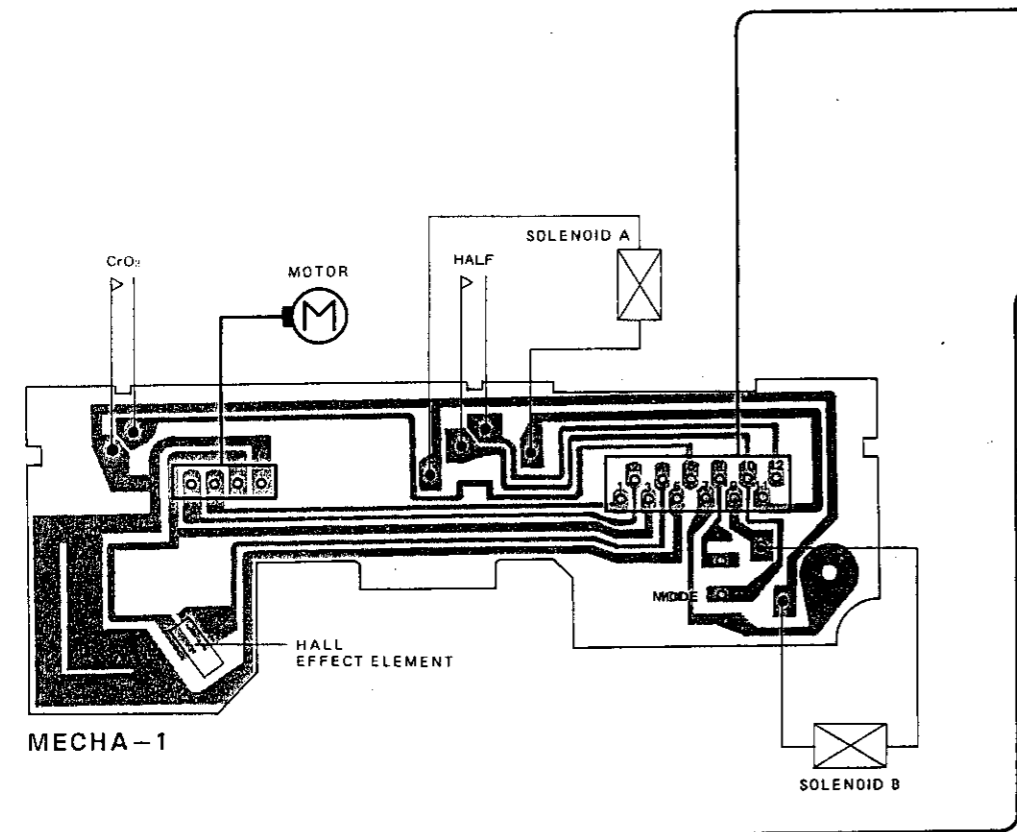

B

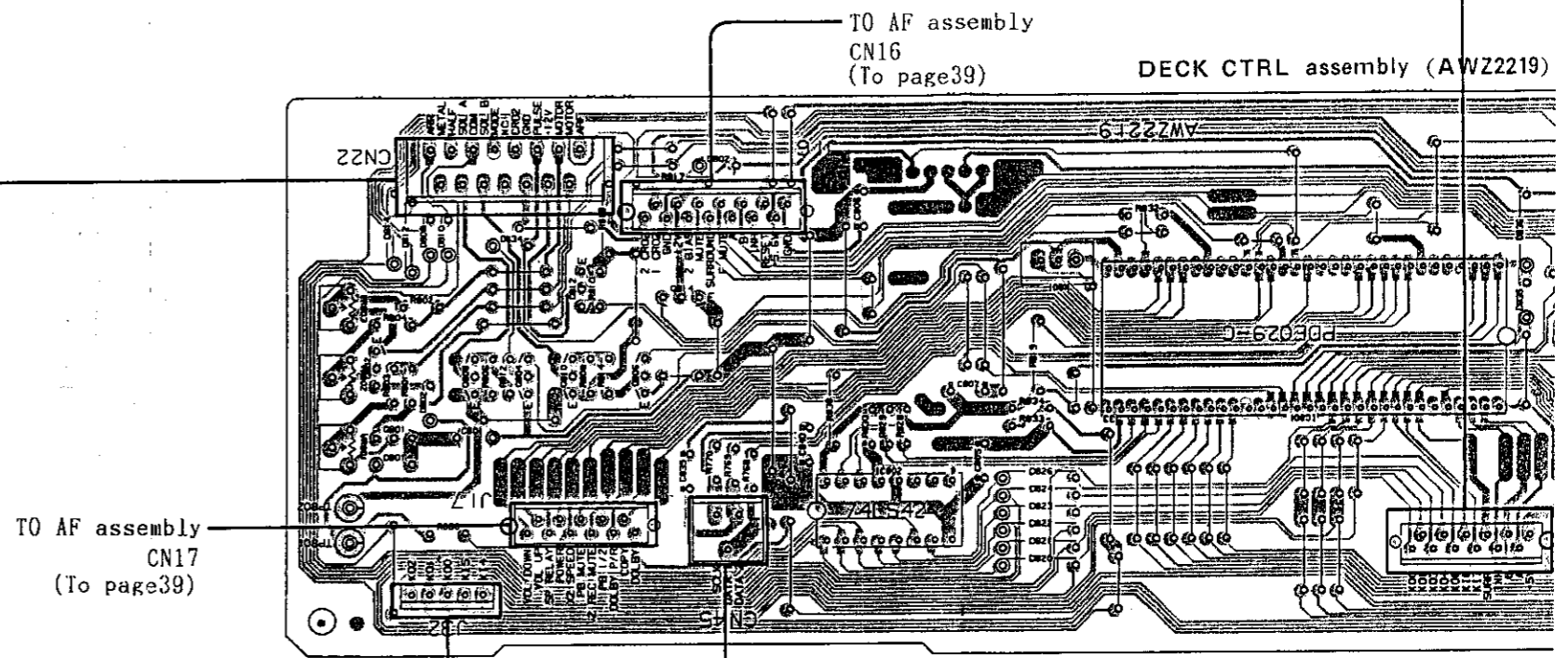

C

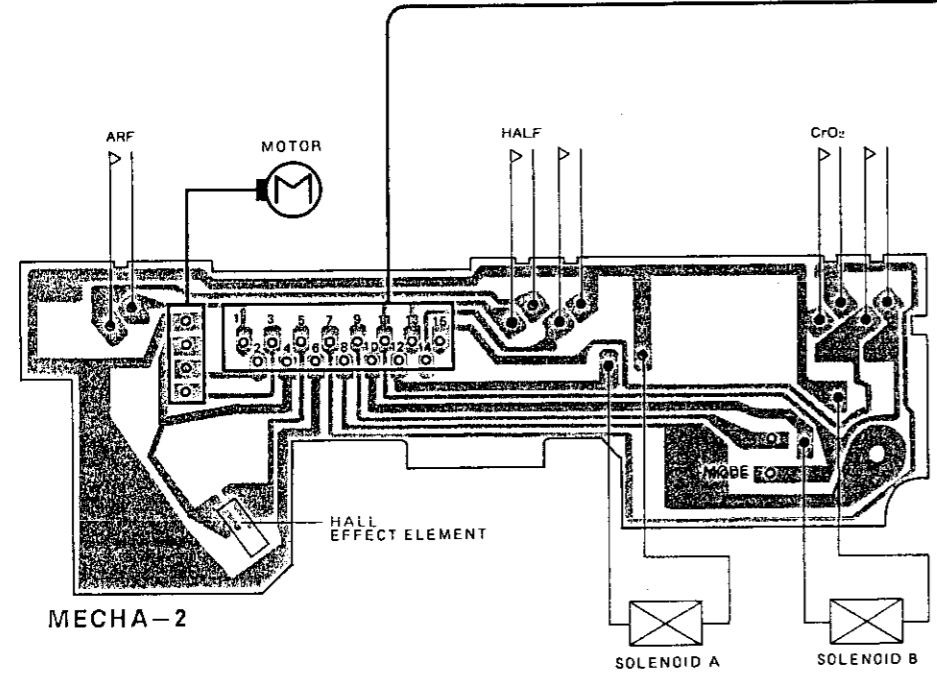

D

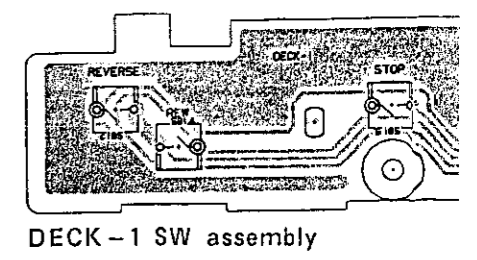
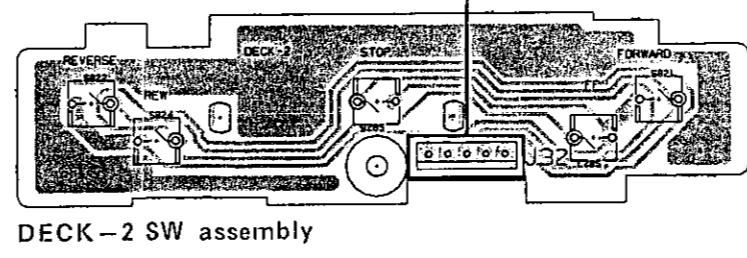

7

8

9

10

11

12

AMP GEQ CTRL assembly (AWZ2218)

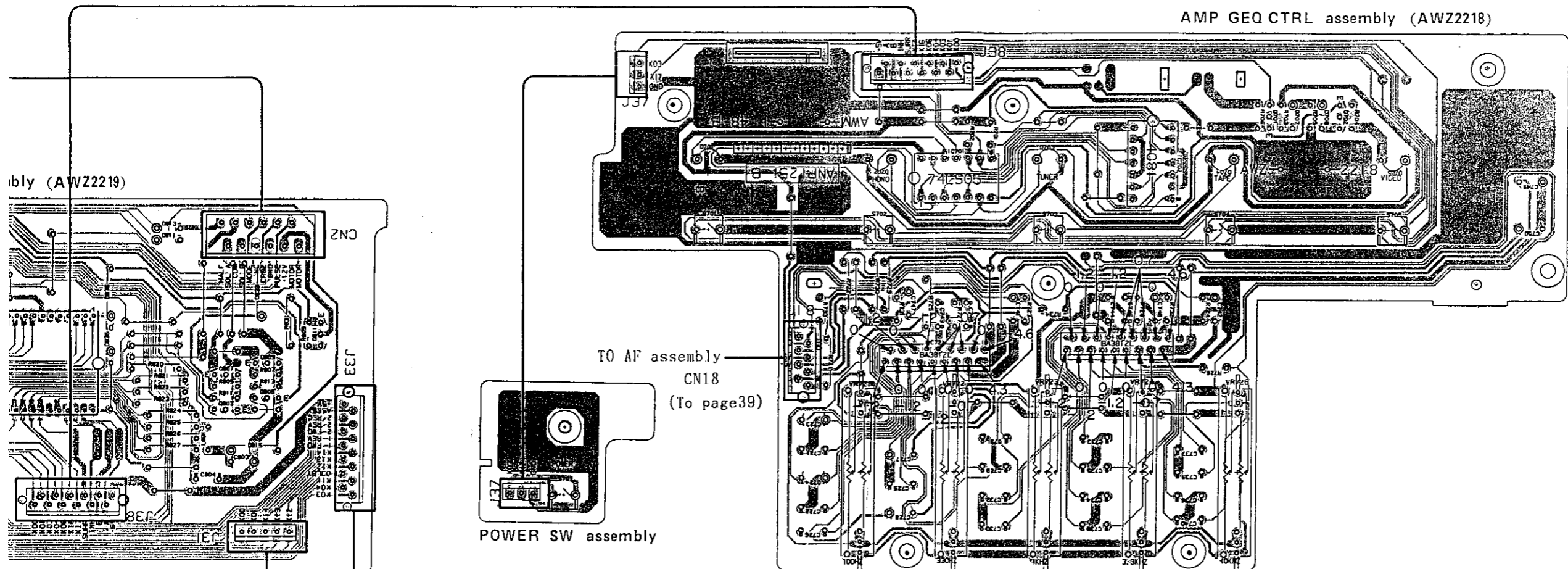

A

B

Assembly (AWZ2219)

TO AF assembly
CN18
(To page 39)

POWER SW assembly

DECK CENTER assembly

Q811
Q807 Q803 Q809 Q805

- NOTE
1. This P.C.B. connection diagram is viewed from the parts mounted side.
 2. The parts which have been mounted on the board can be replaced with those shown with the corresponding wiring symbols listed in the following Table.

P.C.B. pattern diagram indication	Corresponding part symbol	Part Name
Q504		Transistor
Q215		Radiator type transistor
D203		Diode
R237		Resistor
C513		Capacitor (Polarity)
C518		Capacitor (Non-polarity)

C

Others

P.C.B. pattern diagram indication	Part Name
IC	IC
S	Switch
RY	Relay
L	Coil
F	Filter
VR	Variable resistor or Semi-fixed resistor

D

3. The capacitor terminal marked with ⊖ (double circles) shows negative terminal.
4. The diode terminal marked with ⊖ (double circles) shows cathode side.
5. The transistor terminal to which E is affixed shows the emitter.

7

8

9

10

11

12

1

2

3

4

5

6

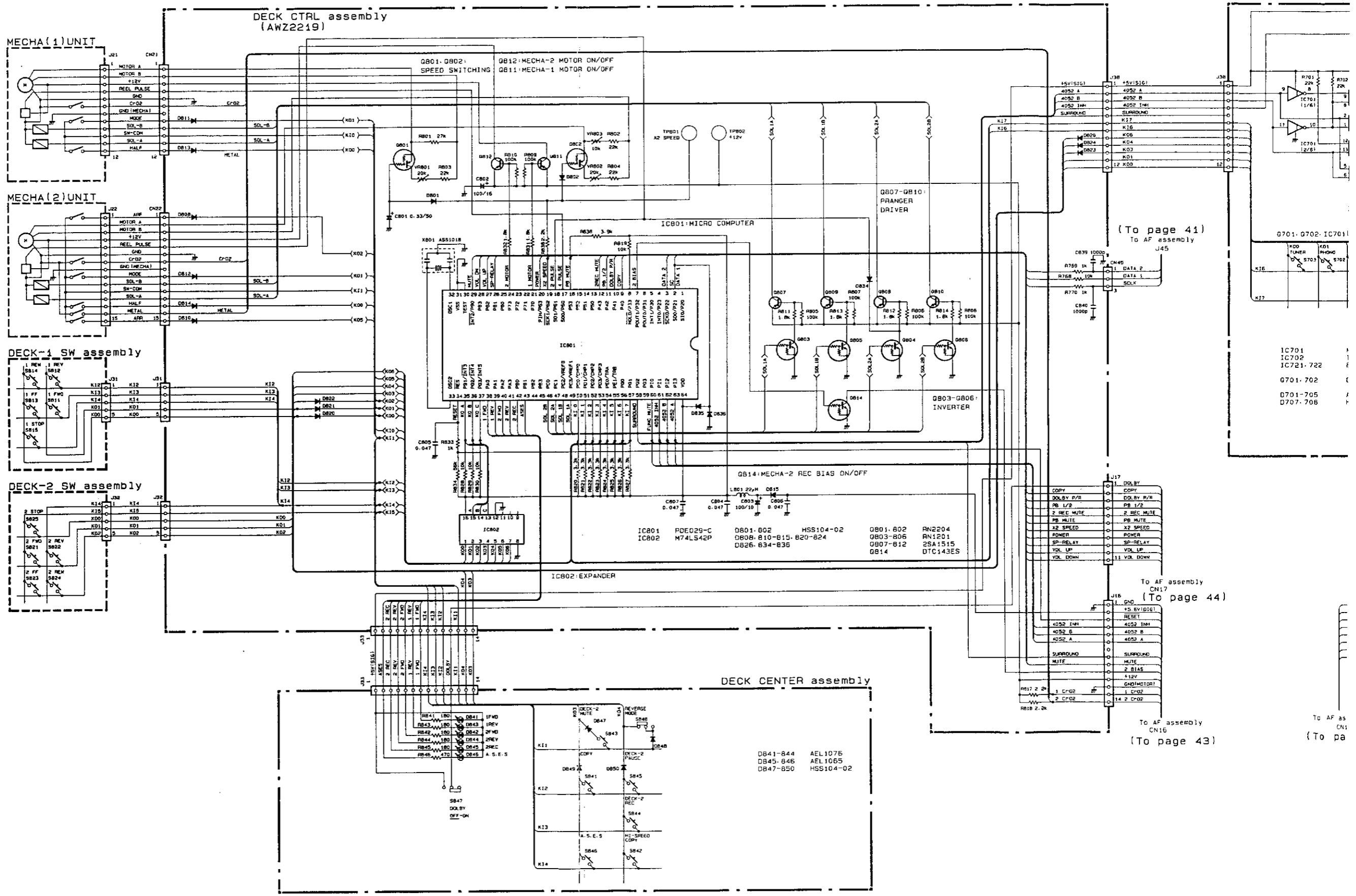

1

2

3

4

5

6

A

B

C

D

AMP. GEQ CTRL asse

(To page 41)
To AF assembly
J45

To AF assembly
CN17
(To page 44)

To AF assembly
CN16
(To page 43)

To AF as
CN1
(To page 41)

G701-G702-IC701

IC701
IC702
IC721-722
0701-702
0701-705
0707-708

DECK CENTER assembly

DB41-844 AEL1076
DB45, 846 AEL1065
DB47-850 HSS104-02

DB17 2.2k
DB18 2.2k
DB19 1k
DB20 1k
DB21 1k
DB22 1k
DB23 1k
DB24 1k
DB25 1k
DB26 1k
DB27 1k
DB28 1k
DB29 1k
DB30 1k
DB31 1k
DB32 1k
DB33 1k
DB34 1k
DB35 1k
DB36 1k
DB37 1k
DB38 1k
DB39 1k
DB40 1k
DB41 1k
DB42 1k
DB43 1k
DB44 1k
DB45 1k
DB46 1k
DB47 1k
DB48 1k
DB49 1k
DB50 1k
DB51 1k
DB52 1k
DB53 1k
DB54 1k
DB55 1k
DB56 1k
DB57 1k
DB58 1k
DB59 1k
DB60 1k
DB61 1k
DB62 1k
DB63 1k
DB64 1k
DB65 1k
DB66 1k
DB67 1k
DB68 1k
DB69 1k
DB70 1k
DB71 1k
DB72 1k
DB73 1k
DB74 1k
DB75 1k
DB76 1k
DB77 1k
DB78 1k
DB79 1k
DB80 1k
DB81 1k
DB82 1k
DB83 1k
DB84 1k
DB85 1k
DB86 1k
DB87 1k
DB88 1k
DB89 1k
DB90 1k
DB91 1k
DB92 1k
DB93 1k
DB94 1k
DB95 1k
DB96 1k
DB97 1k
DB98 1k
DB99 1k
DB100 1k

4

5

6

7

8

9

AMP. GEQ CTRL assembly (AWZ221B)

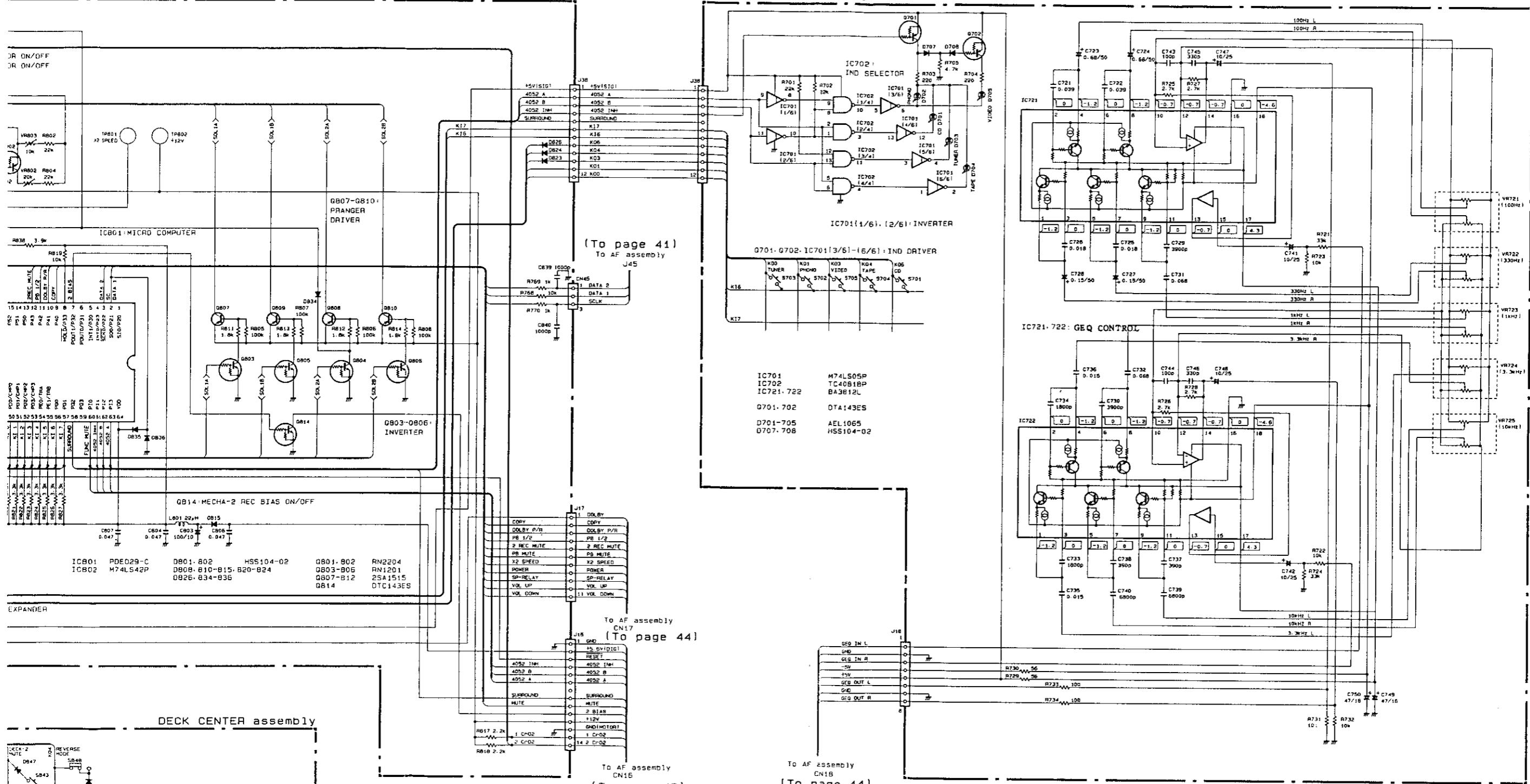

A

B

C

D

DECK CENTER assembly

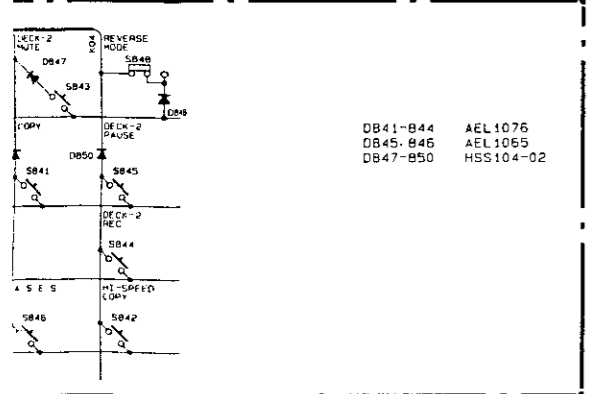

4

5

6

7

8

9

4.3 FUNCTION assembly

A

B

C

D

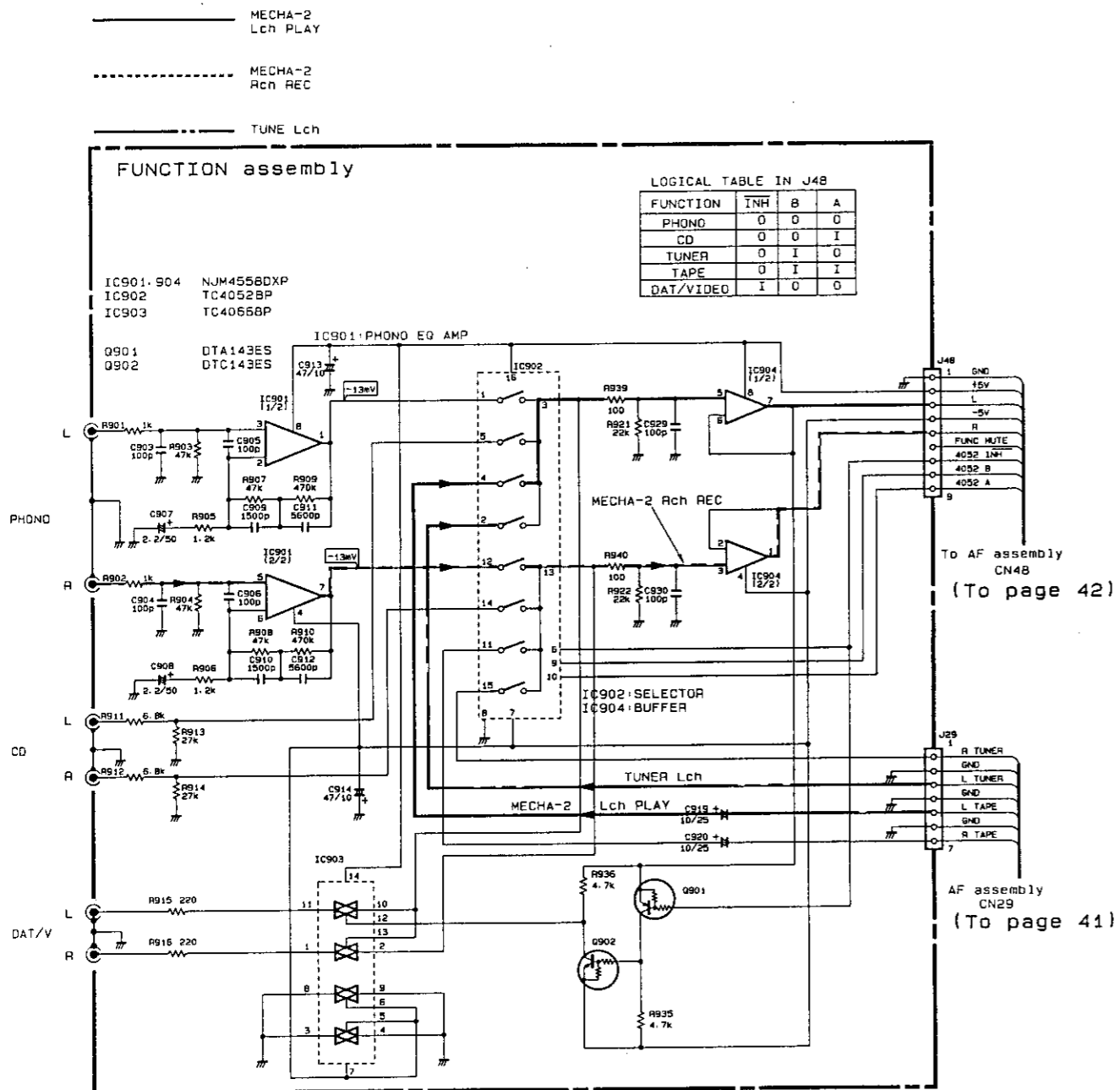

TO AF assembly CN29 (To page 39)

TO AF assembly CN48 (To page 39)

TO AF assembly CN48 (To page 39)

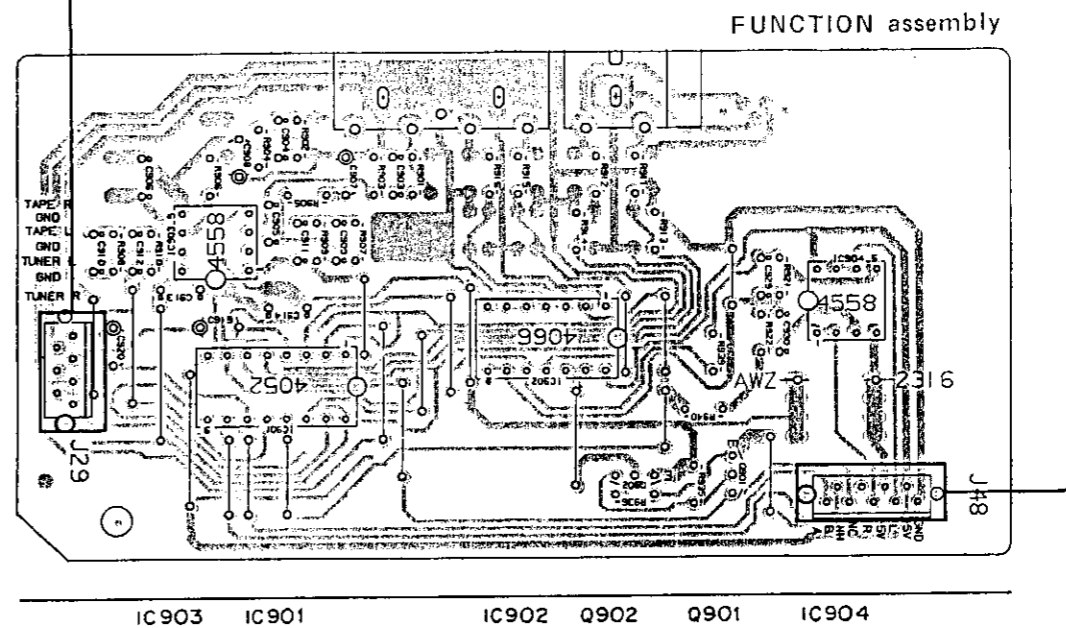

NOTE

- This P.C.B. connection diagram is viewed from the parts mounted side.
- The parts which have been mounted on the board can be replaced with those shown with the corresponding wiring symbols listed in the following Table.

P.C.B. pattern diagram indication	Corresponding part symbol	Part Name
		Transistor
		Radiator type transistor
		Diode
		Resistor
		Capacitor (Polarity)
		Capacitor (Non-polarity)

Others

P.C.B. pattern diagram indication	Part Name
IC	IC
S	Switch
RY	Relay
L	Coil
F	Filter
VR	Variable resistor or Semi-fixed resistor

- The capacitor terminal marked with ⊕ (double circles) shows negative terminal.
- The diode terminal marked with ⊕ (double circles) shows cathode side.
- The transistor terminal to which E is affixed shows the emitter.

4

5

6

7

8

9

NOTE:
This picture shows the foil side of the printed circuit.

TO AF assembly
CN29
(To page39)

TO AF assembly
CN48
(To page39) (02339 OT)

TO AF assembly
CN28
(To page39)

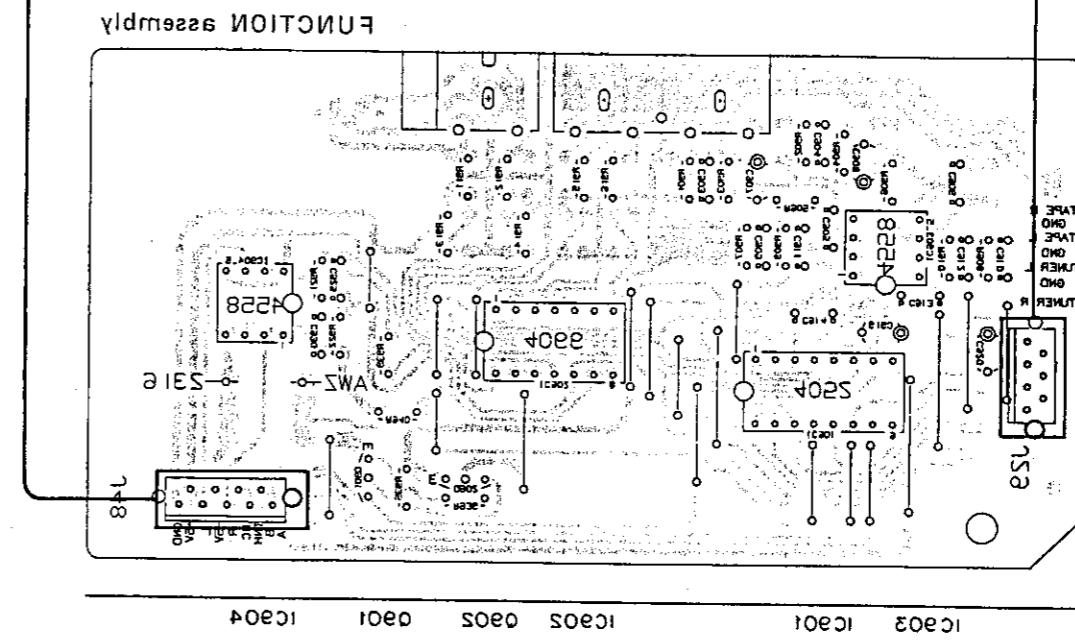
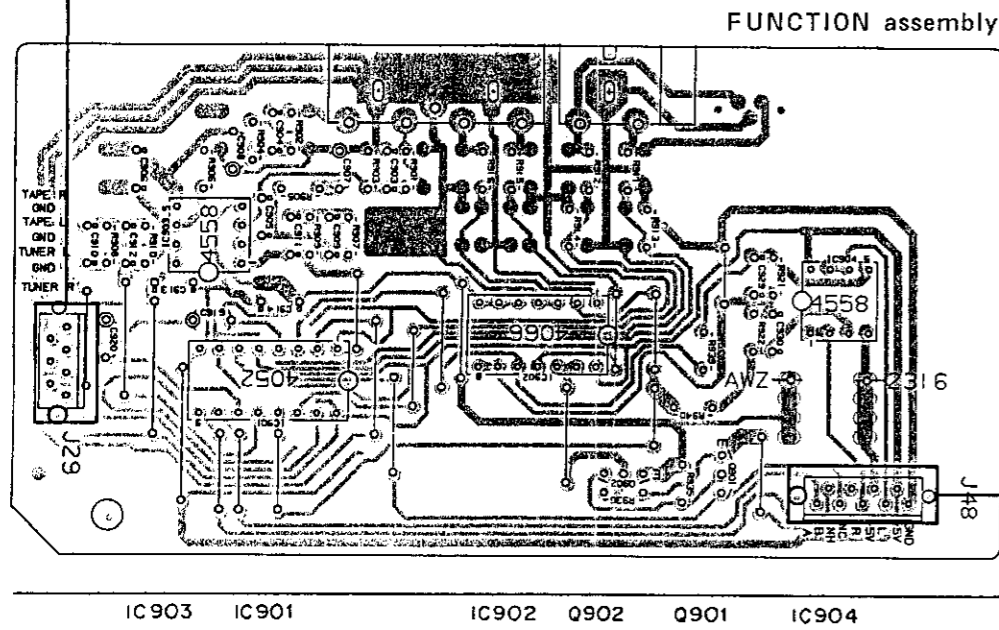

NOTE

1. This P.C.B connection diagram is viewed from the parts mounted side.
2. The parts which have been mounted on the board can be replaced with those shown with the corresponding wiring symbols listed in the following Table.

P.C.B. pattern diagram indication	Corresponding part symbol	Part Name
		Transistor
		Radiator type transistor
		Diode
		Resistor
		Capacitor (Polarity)
		Capacitor (Non-polarity)

Others

P.C.B. pattern diagram indication	Part Name
IC	IC
S	Switch
RY	Relay
L	Coil
F	Filter
VR	Variable resistor or Semi-fixed resistor

3. The capacitor terminal marked with ⊕ (double circles) shows negative terminal.
4. The diode terminal marked with ⊕ (double circles) shows cathode side.
5. The transistor terminal to which E is affixed shows the emitter.

A

B

C

D

4

5

6

7

8

9

1 4 1 1 2 1 6 7 8 1 9

IC205
IC204
IC203
IC202
IC201
IC200
IC199
IC198
IC197
IC196
IC195
IC194
IC193
IC192
IC191
IC190
IC189
IC188
IC187
IC186
IC185
IC184
IC183
IC182
IC181
IC180
IC179
IC178
IC177
IC176
IC175
IC174
IC173
IC172
IC171
IC170
IC169
IC168
IC167
IC166
IC165
IC164
IC163
IC162
IC161
IC160
IC159
IC158
IC157
IC156
IC155
IC154
IC153
IC152
IC151
IC150
IC149
IC148
IC147
IC146
IC145
IC144
IC143
IC142
IC141
IC140
IC139
IC138
IC137
IC136
IC135
IC134
IC133
IC132
IC131
IC130
IC129
IC128
IC127
IC126
IC125
IC124
IC123
IC122
IC121
IC120
IC119
IC118
IC117
IC116
IC115
IC114
IC113
IC112
IC111
IC110
IC109
IC108
IC107
IC106
IC105
IC104
IC103
IC102
IC101
IC100
IC99
IC98
IC97
IC96
IC95
IC94
IC93
IC92
IC91
IC90
IC89
IC88
IC87
IC86
IC85
IC84
IC83
IC82
IC81
IC80
IC79
IC78
IC77
IC76
IC75
IC74
IC73
IC72
IC71
IC70
IC69
IC68
IC67
IC66
IC65
IC64
IC63
IC62
IC61
IC60
IC59
IC58
IC57
IC56
IC55
IC54
IC53
IC52
IC51
IC50
IC49
IC48
IC47
IC46
IC45
IC44
IC43
IC42
IC41
IC40
IC39
IC38
IC37
IC36
IC35
IC34
IC33
IC32
IC31
IC30
IC29
IC28
IC27
IC26
IC25
IC24
IC23
IC22
IC21
IC20
IC19
IC18
IC17
IC16
IC15
IC14
IC13
IC12
IC11
IC10
IC9
IC8
IC7
IC6
IC5
IC4
IC3
IC2
IC1

TO TRFR
TO DECK CTRL assembly
C445
(To page 28)
TO FUNCTION assembly
128
(To page 33)

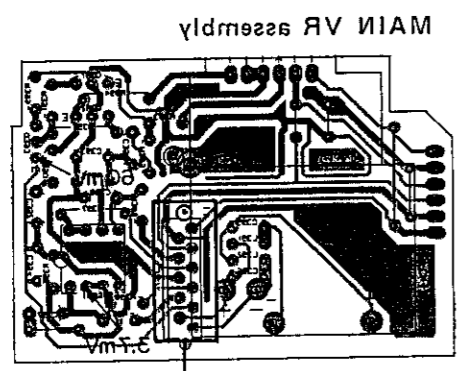

TO DECK CTRL assembly
117
(To page 28)

TO DECK CTRL assembly
116
(To page 28)

A

B

C

D

9

8

7

6

5

4

3

2

1

14 (WASS17)

1

S

3

4

R

6

IC201 IC205 IC202 IC204
IC203 IC206
022-0228
0251 0252
0491-0494 IC201
IC255 IC253
0491-0488
0251-0254 IC411
0411 0418
IC421 IC415
0211-0214
0280-0283 0284
0251
0411 0418
IC421 IC415
0211-0214
VR411
VR415
VR455 VR457
VR421 - VR429
0280-0428
0421 0421-0421-0

NOTE:

This picture shows the foil side of the printed circuit.

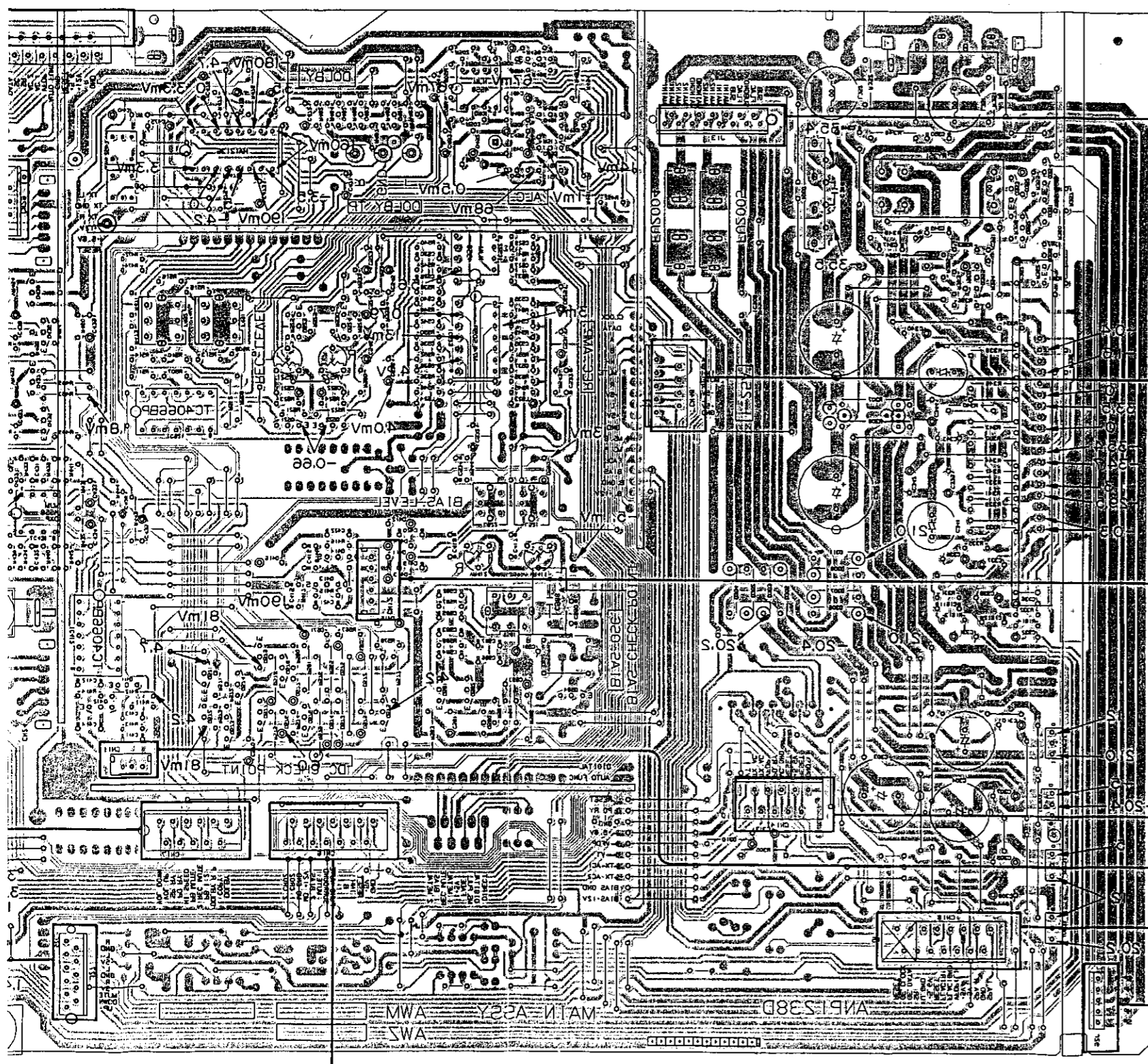

A

B

C

D

TO TRANS CONNECT assembly
713 (To page 7)

TO FUNCTION assembly
718 (To page 3)

TO POWER SUPPLY assembly
714 (To page 6)

TO AMP. GEO CTRL assembly
718 (To page 8)

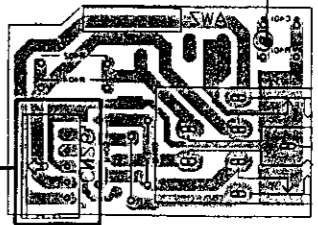
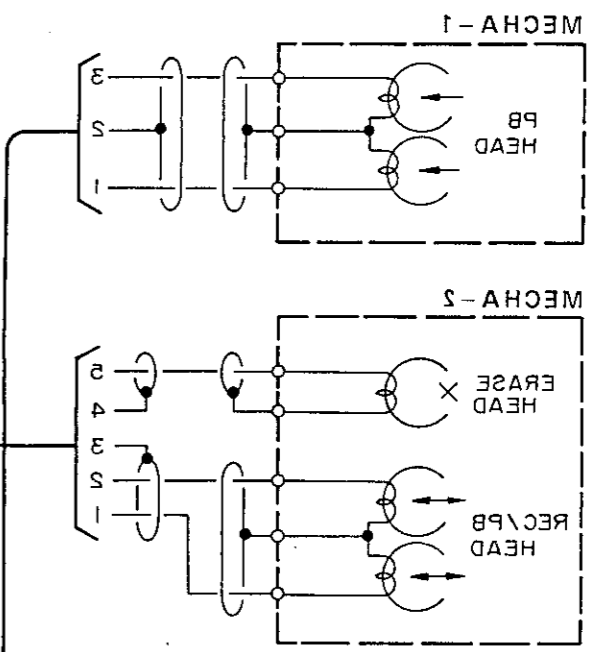

TO DECK CTRL assembly
716 (To page 5)

1

S

3

4

R

6

4.4 AF (AWZ2217), MAIN VR,
HEAD PHONE assembly

035-0356
IC303 IC304
IC301 IC302

IC306

0491-0494 IC501
IC522 IC523
0527
0580-0582 0584

0481-0483 IC471
0521-0524 IC521
0414 0415
0571-0579

0435-0438
IC431 IC431-0434
IC412
0411 0412 IC412

VR411 VR412 VR522 VR521 VR451 - VR454 V1

A

TO TRANS CONNECT assembly
(To page47) J13

B

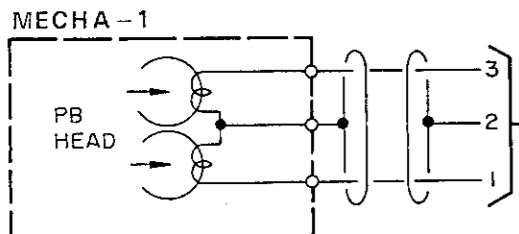

TO FUNCTION assembly
(To page33) J48

C

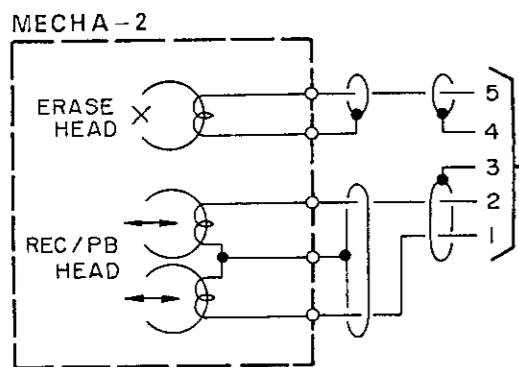

TO POWER SUPPLY assembly
(To page46) J14

TO AMP.GEQ CTRL assembly
(To page28) J18

D

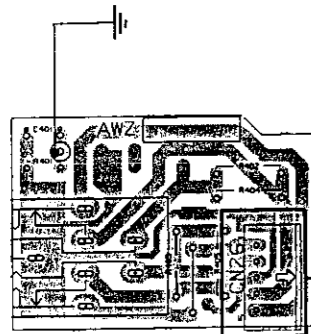

HEAD PHONE assembly

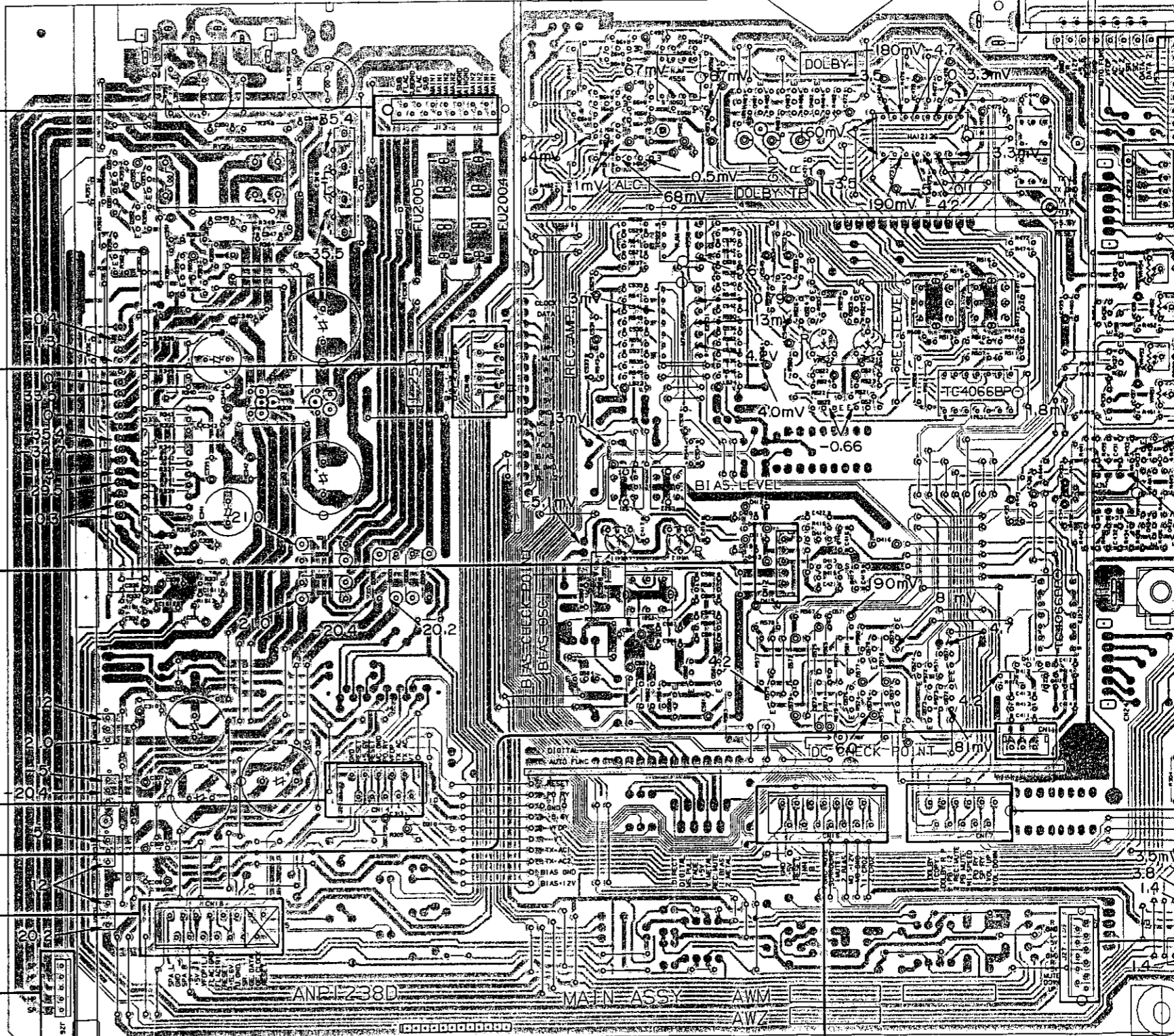

AF assembly (AWZ2217)

TO DECK CTRL assembly
J16 (To page26)

4

5

6

7

8

9

-0356

IC306

0491-0494 IC501
IC522 IC523
0527

0481-0483 IC471
0521-0524 IC521
0414 0415

0435-0438
IC431 0431-0434

504
502

VR411 VR412

VR522 VR521

VR451 - VR454

IC332

VR391

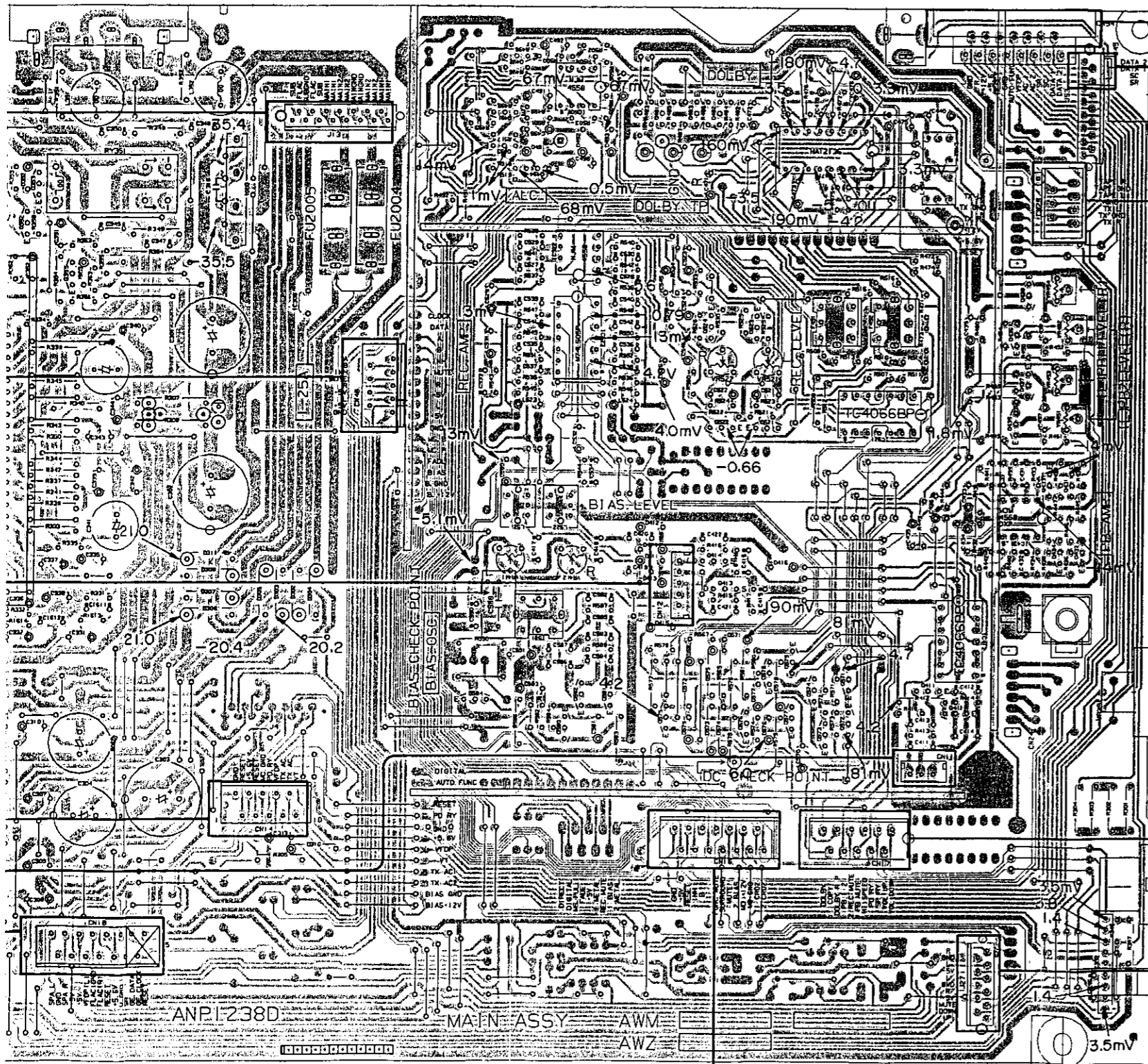

TO TUNFR
TO DECK CTRL assembly
CN45
(To page26)

TO FUNCTION assembly
J29
(To page33)

TO DECK CTRL assembly
J17
(To page26)

TO DECK CTRL assembly
J16
(To page26)

NOTE

1. This P.C.B connection diagram is viewed from the parts mounted side.
2. The parts which have been mounted on the board can be replaced with those shown with the corresponding wiring symbols listed in the following Table.

P.C.B. pattern diagram indication	Corresponding part symbol	Part Name
		Transistor
		Resistor type transistor
		Diode
		Resistor
		Capacitor (Polarity)
		Capacitor (Non-polarity)

Others

P.C.B. pattern diagram indication	Part Name
IC	IC
S	Switch
RY	Relay
L	Coil
F	Filter
VR	Variable resistor or Semi-fixed resistor

3. The capacitor terminal marked with ⊕ (double circles) shows negative terminal.
4. The diode terminal marked with ⊕ (double circles) shows cathode side.
5. The transistor terminal to which E is affixed shows the emitter.

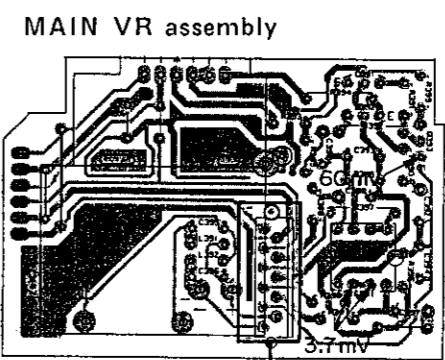

(AWZ2217)

A

B

C

D

4

5

6

7

8

9

1 | 2 | 3 | 4 | 5 | 6

A

B

C

D

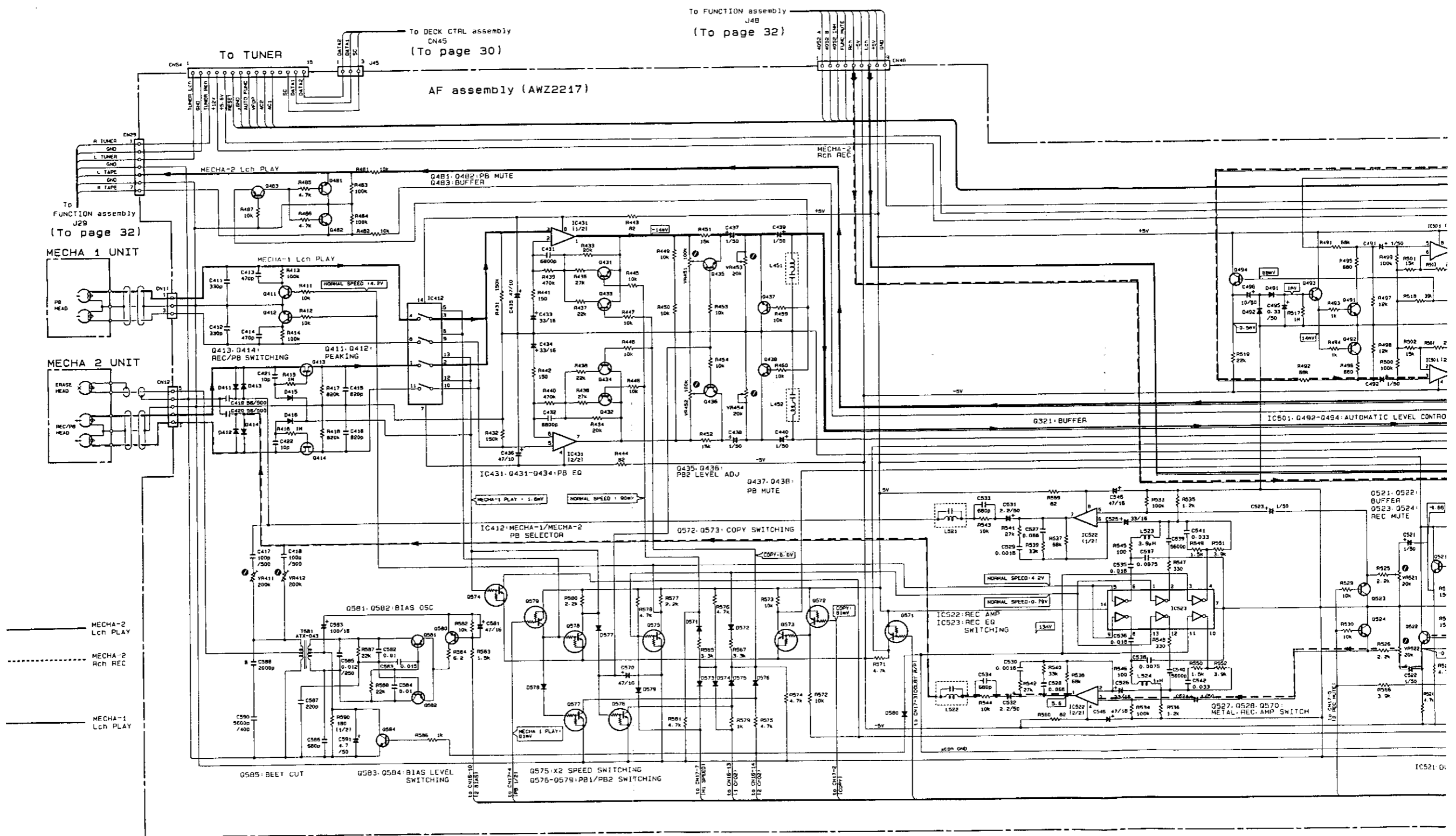

1 | 2 | 3 | 4 | 5 | 6

7

8

9

10

11

12

72 BUFFER

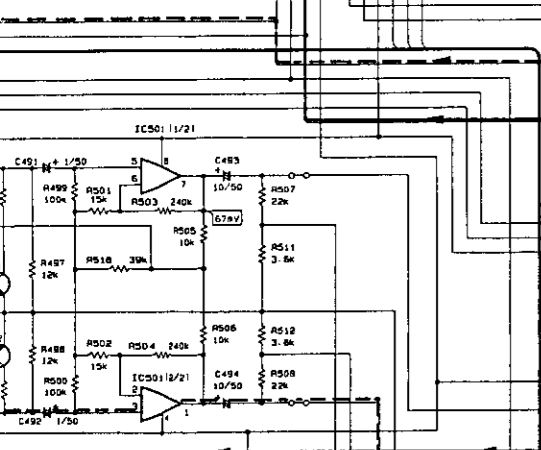
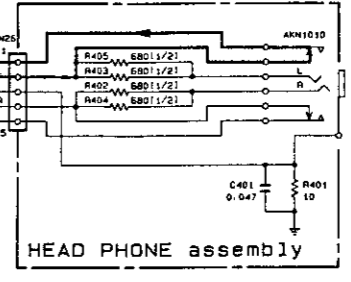
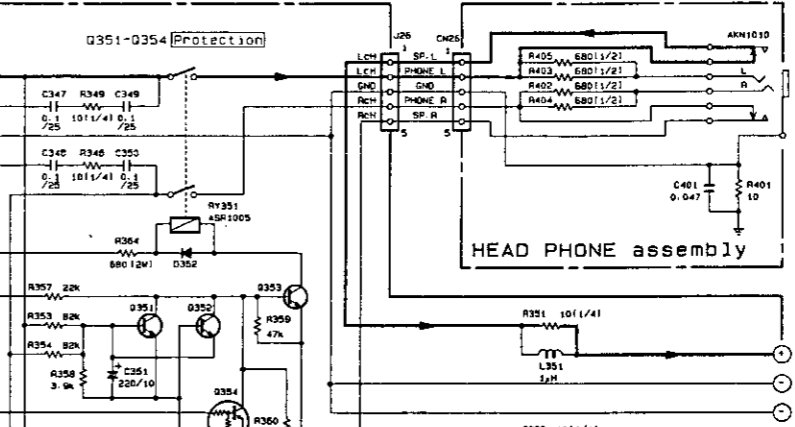
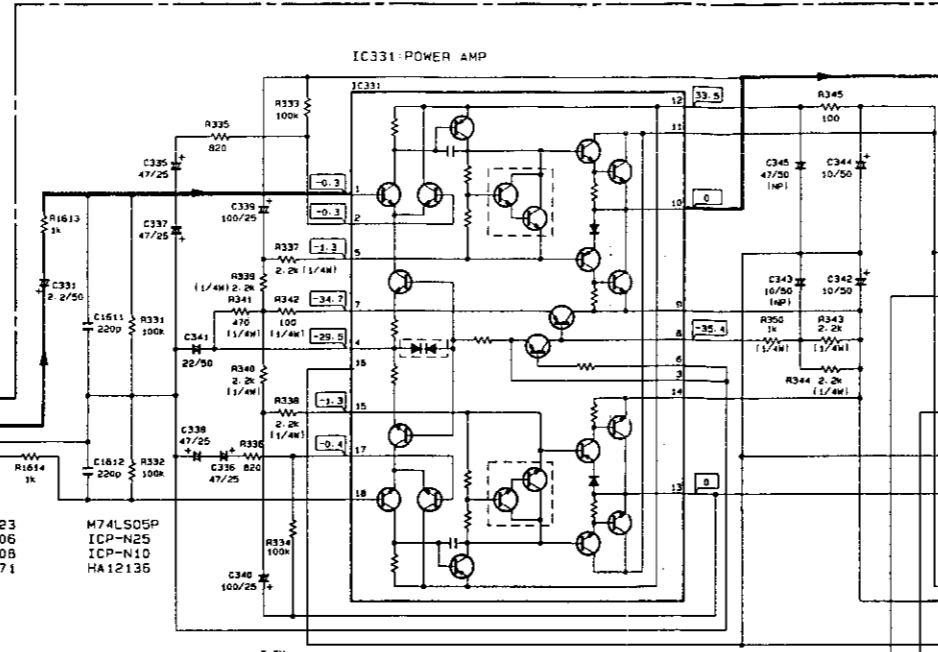
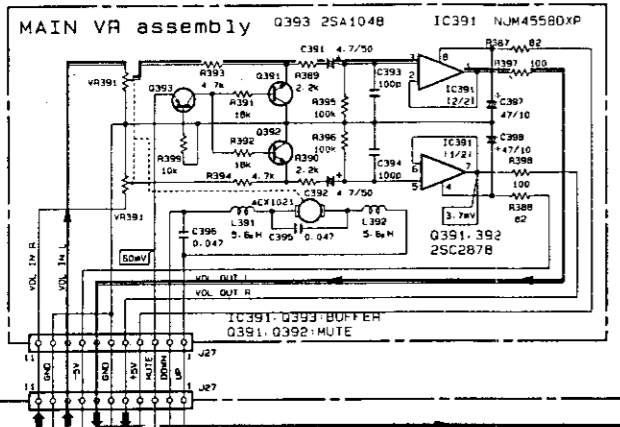

- IC301: 304 MC7812CT
- IC302 NJM78M05FA
- IC303 NJM78M05FA
- IC431: 501-522 NJM45580XP
- IC331 IC331
- IC332 TA7281S
- IC412: 523 TC4056BP
- IC523 M74LS05P
- IC306 ICP-N25
- IC309 ICP-N10
- IC471 HA12135

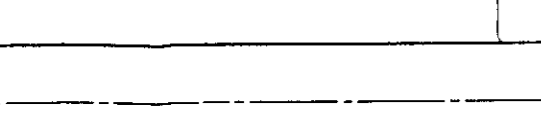
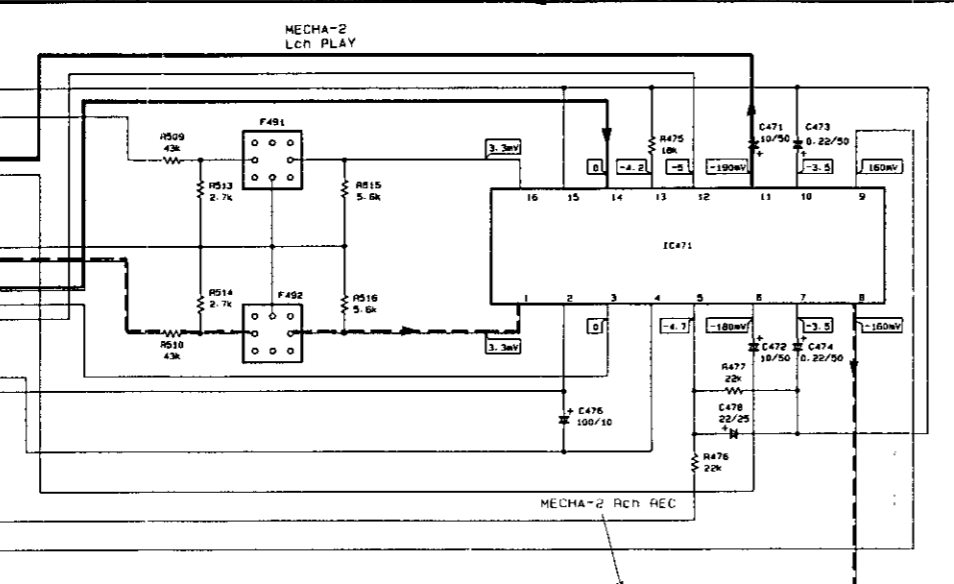
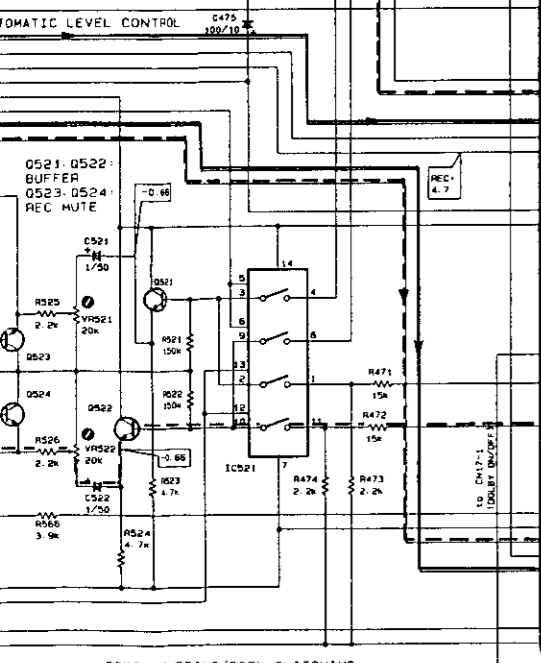

- 0310 RD7.5ESB
- 0321: 411-416-491, 492 HSS104-02
- D301 D301
- D309 RD5.6ESB
- D302: 308, 311 S5566
- HSS104-02
- ABV402

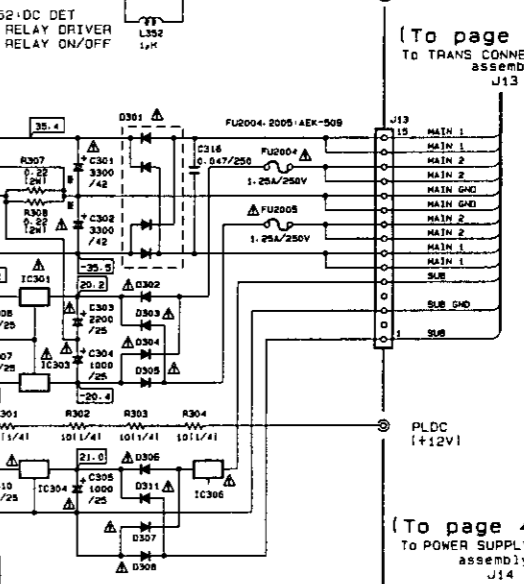
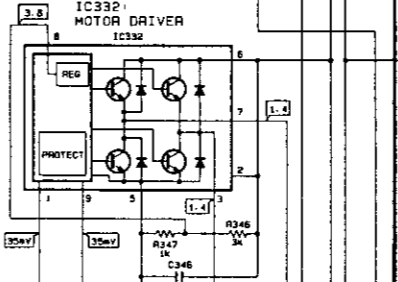
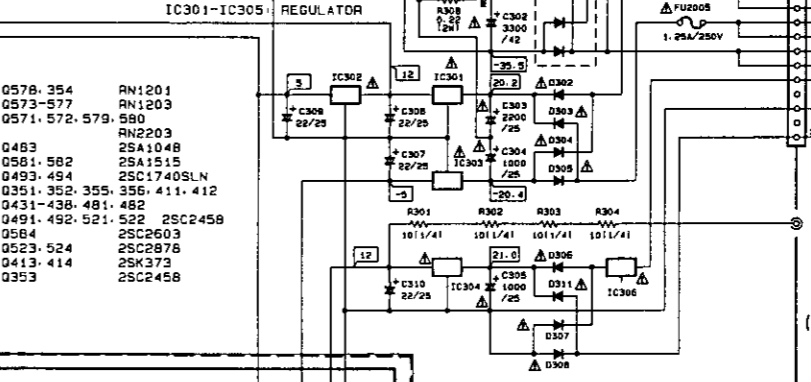

(To page 45)
To TRANS CONNECT assembly J13

(To page 45)
To POWER SUPPLY assembly J14

To AMP GEG CTRL assembly J18
(To page 31)

A

B

C

D

7

8

9

10

11

12

To DECK CTRL assembly J16
(To page 30)

To DECK CTRL assembly J17
(To page 30)

4.5 POWER SUPPLY (AWZ2241), CONNECT and TRANS CONNECT assembly

NOTE
 1. This P.C.B. connection dia
 2. The parts which have be
 with the corresponding w
 P.C.B. pattern diagram indica
 Q504
 Q215
 Q203
 R237
 C513
 C518
 Other
 P.C.B. pattern diagram indica
 IC
 S
 RY
 L
 F
 VR
 3. The capacitor terminal m
 4. The diode terminal mark
 5. The transistor terminal tc

A

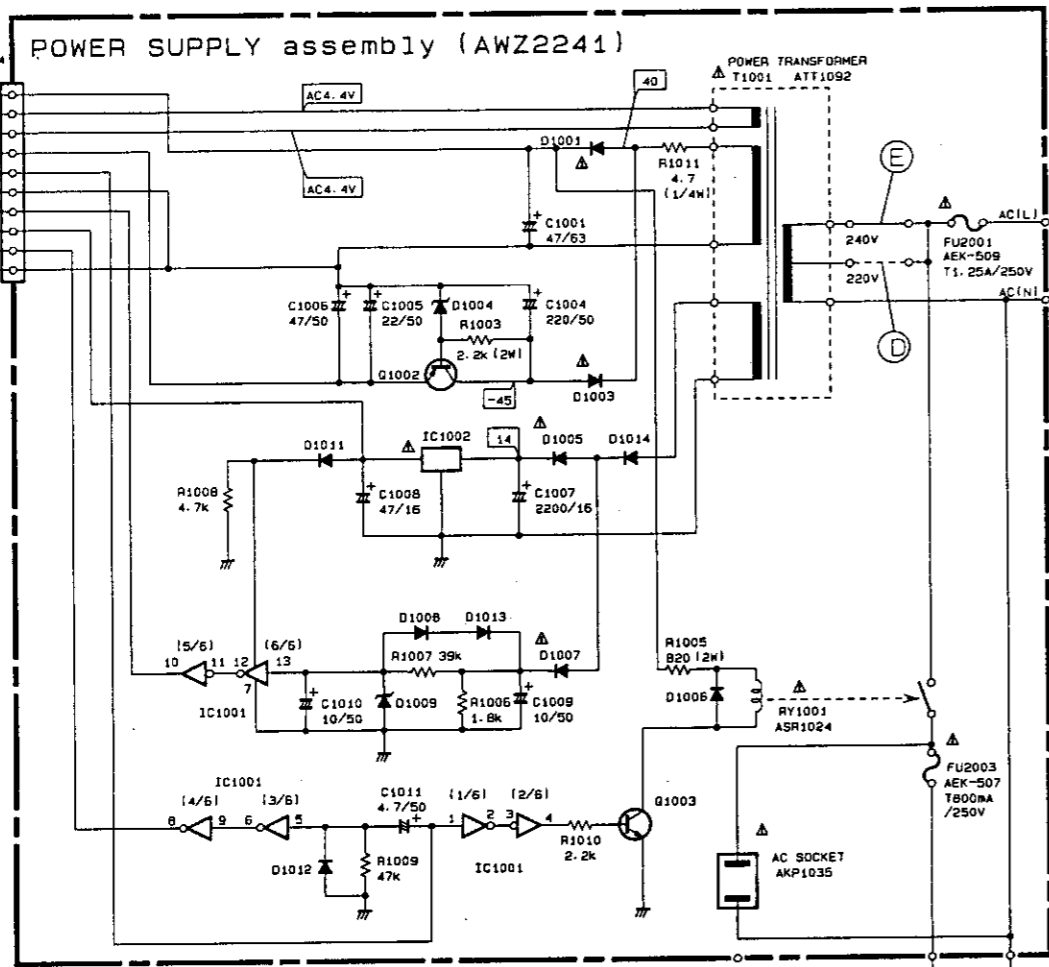

To AF assembly
 CN14
 (To page 44)

B

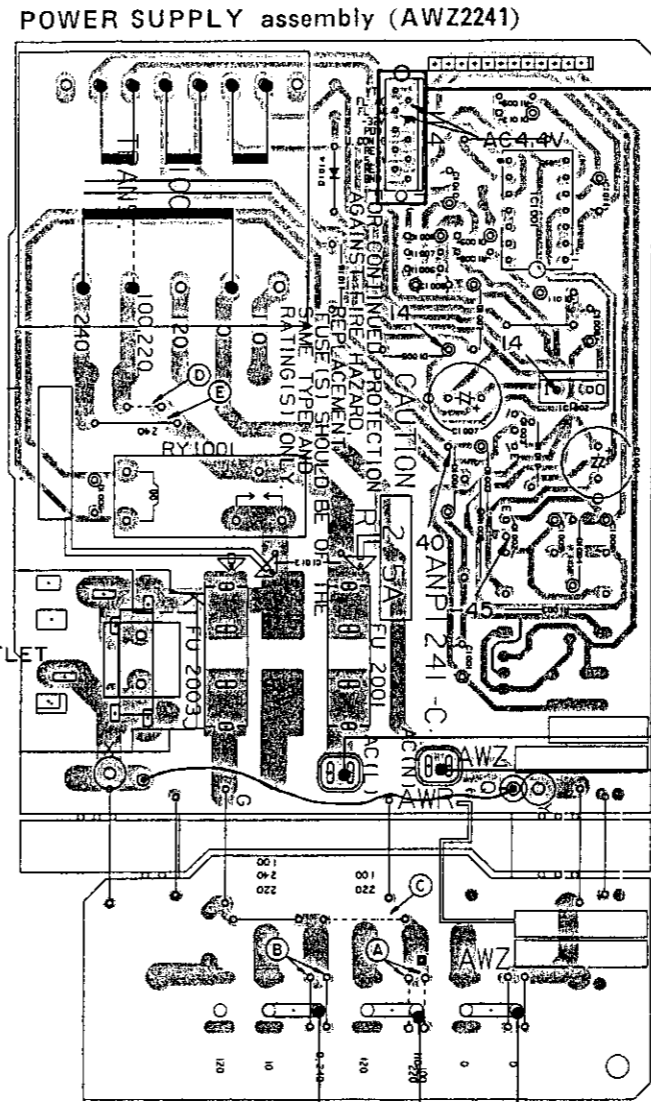

TO AF assembly
 CN14
 (To page 39)

C

IC1001	TC4069UBP	D1001, 1003, 1005, 1007	S5566
IC1002	NJM78M56FA	D1014	RD33ESB2
D1003	2SC2240	D1004	HSS104-02
D1002	2SB560	D1006, 1008, 1011-1013	RD5.1ESB
		D1009	

D

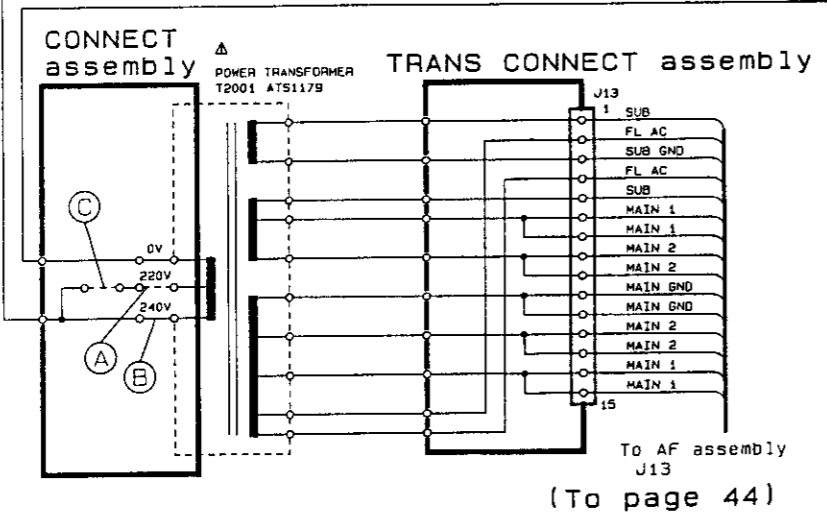

Line Voltage Selection (FOR HB AND HE TYPES)

- Line voltage can be changed with the following steps.
 1. Disconnect the AC power cord.
 2. Remove the top cover.
 3. Change the position of the jumper wires (A-E) as follows.

Jumper wire	220V	240V
(A)	○	×
(B)	×	○
(C)	○	×
(D)	○	×
(E)	×	○

○: Be needed
 ×: Be needless

4. Stick the line voltage label on the rear panel.

Part No.	Description
AAX-193	220V label
AAX-192	240V label

TO AF assembly
 J13
 (To page 39)

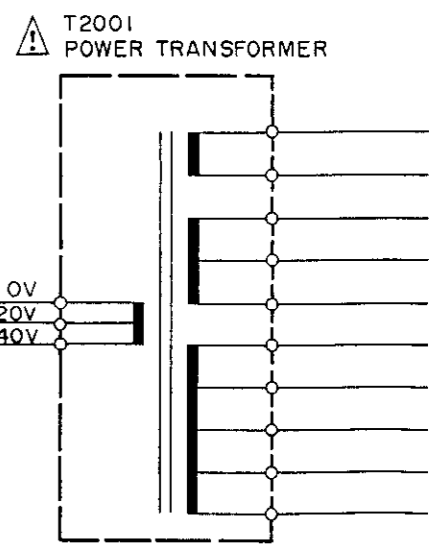

NOTE

1. This P.C.B. connection diagram is viewed from the parts mounted side.
2. The parts which have been mounted on the board can be replaced with those shown with the corresponding wiring symbols listed in the following Table.

P.C.B. pattern diagram indication	Corresponding part symbol	Part Name
		Transistor
		Radiator type transistor
		Diode
		Resistor
		Capacitor (Polarity)
		Capacitor (Non-polarity)

Others

P.C.B. pattern diagram indication	Part Name
IC	IC
S	Switch
RY	Relay
L	Coil
F	Filter
VR	Variable resistor or Semi-fixed resistor

3. The capacitor terminal marked with ⊕ (double circles) shows negative terminal.
4. The diode terminal marked with ⊕ (double circles) shows cathode side.
5. The transistor terminal to which E is affixed shows the emitter.

NOTE:

This picture shows the foil side of the printed circuit.

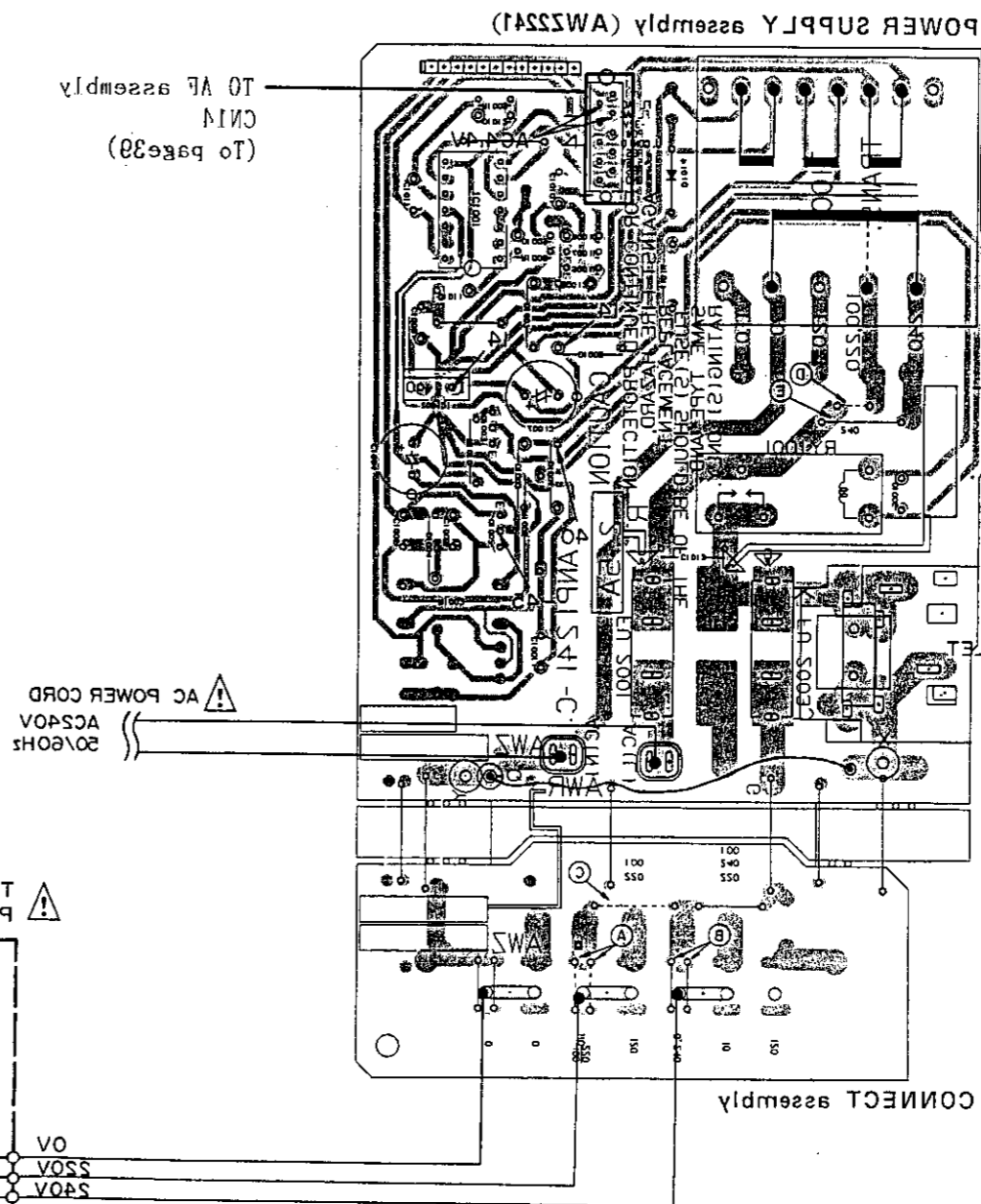

A
B
C
D

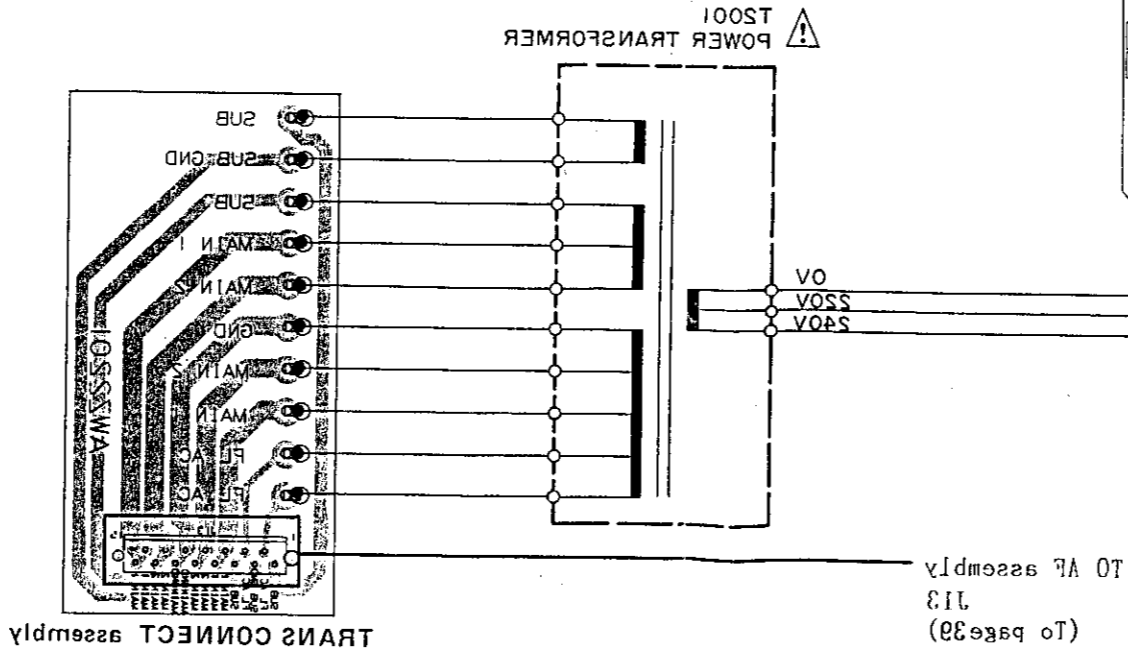
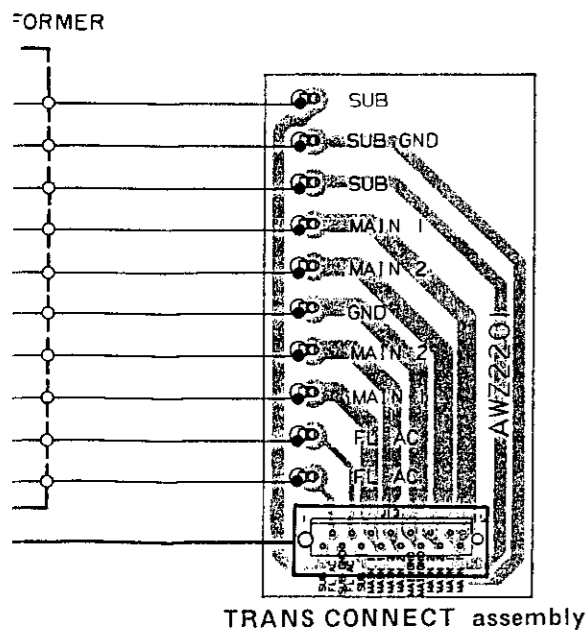

5. ELECTRICAL PARTSLIST

NOTES:

- Parts without part number cannot be supplied.
- Parts marked by "⊙" are not always kept in stock. Their delivery time may be longer than usual or they may be unavailable.
- The ⚠ mark found on some component parts indicates the importance of the safety factor of the part. Therefore, when replacing, be sure to use parts of identical designation.
- When ordering resistors, first convert resistance values into code form as shown in the following examples.

Ex. 1 When there are 2 effective digits (any digit apart from 0), such as 560 ohm and 47k ohm (tolerance is shown by J = 5%, and K = 10%).

560Ω	56 × 10 ¹	561.....	RD1/4PS	Ⓜ	Ⓜ	Ⓜ	J
47kΩ	47 × 10 ³	473.....	RD1/4PS	Ⓜ	Ⓜ	Ⓜ	J
0.5Ω	0R5.....		RN2H	Ⓜ	Ⓜ	Ⓜ	K
1Ω	010.....		RSIP	Ⓜ	Ⓜ	Ⓜ	K

Ex. 2 When there are 3 effective digits (such as in high precision metal film resistors).

5.62kΩ	562 × 10 ¹	5621.....	RN1/4SR	Ⓜ	Ⓜ	Ⓜ	F
--------	-----------------------	-----------	---------	---	---	---	---

Miscellaneous Parts

P.C.BOARD ASSEMBLIES

Mark	Symbol & Description	Part No.
	Function assembly	
	AF assembly	AWZ2217
	MAIN VR assembly	
	HEAD PHONO assembly	
	TRANS CONNECT assembly	
	AMP, GEO, CTRL assembly	AWZ2218
	DECK - 1 SW assembly	
	DECK - 2 SW assembly	
	DECK CTRL assembly	AWZ2219
	POWER SW assembly	
	DECK CENTER assembly	
	POWER SUPPLY assembly	AWZ2241
	CONNECT assembly	

OTHERS

Mark	Symbol & Description	Part No.
⚠	T2001 Power Transformer (AC220V/240V)	ATS1179
⚠	FU2003 Fuse (T800mA/250V)	AEK - 507
⚠	FU2001, FU2004, FU2005 Fuse (T1.25A/250V)	AEK - 509
⚠	AC Power cord	ADG - 063
	Hall IC	AZE1018
	Leaf SW	AZS1054
	Leaf SW	AZS1034
	P.C.BOARD	AZN1835
	Bobbin	AZS1035
	Bobbin	AZS1036
	Motor assembly	AZX1020
	Head frame assembly	AZP1023
	Head frame assembly	AZP1016

FUNCTION assembly

SEMICONDUCTORS

Mark	Symbol & Description	Part No.
	IC903, IC904	NJM4558DXP
	IC901	TC4052BP
	IC902	TC4066BP
	Q901	DTA143ES
	Q902	DTC143ES

CAPACITORS

Mark	Symbol & Description	Part No.
	C903 - C906, C929, C930	CCCSL101J50
	C907, C908	CEAS2R2M50
	C909, C910	CKCYB152K50
	C911, C912	CKCYB562K50
	C913, C914	CEAS470M10
	C919, C920	CEAS100M25

RESISTORS

Mark	Symbol & Description	Part No.
	All resistors	RD1/8PM□□□J

OTHERS

Mark	Symbol & Description	Part No.
	Terminal 4P (VIDEO, PHONO)	AKB1085
	Terminal 2P (CD)	AKB1086

AF assembly (AWZ2217)

SEMICONDUCTORS

Mark	Symbol & Description	Part No.
	IC471	HA12136
	IC306	ICP - N38
	IC301, IC304	MC7812CT
	IC523	M74LS05P
	IC431, IC501, IC522	NJM4558DXP

Mark	Symbol & Description	Part No.
	IC302	NJM78M05FA
	IC303	NJM79M05FA
	IC331	STK4142-2GP
	IC332	TA7291S
	IC412,IC521	TC4066BP
	Q578	RN1201
	Q354,Q573-Q577	RN1203
	Q571,Q572,Q579	RN2203
	Q355,Q483,Q580	2SA1048
	Q581,Q582	2SA1515
	Q493,Q494	2SC1740SLN
	Q351-Q353,Q356,Q411,Q412, Q431-Q438,Q481,Q482,Q491, Q492,Q521,Q522	2SC2458
	Q584	2SC2603
	Q523,Q524	2SC2878
	Q413,Q414	2SK373
	D351,D352,D411-D416,D491, D492,D571-D580	HSS-104-02
	D301	RBV402
	D310 Zener Diode	RD7.5ESB
	D302-D308,D311	S5566

RELAY

Mark	Symbol & Description	Part No.
	RY351	ASR1005

COILS & TRANSFORMERS

Mark	Symbol & Description	Part No.
	F491,F492 Dolby filter	ATF1064
	L351,L352 AF choke coil	ATH-133
	L521,L522 Trap coil	ATM-037
	L451,L452 Trap coil	ATM1001
	T581 Bias oscillator transformer	ATX-043
	L523,L524 Inductor	LTA392J

CAPACITORS

Mark	Symbol & Description	Part No.
	C588 (2000P/630)	ACE1020
	C301,C302 (2200/42)	ACH1109
	C417,C418	CCCSL101K500
	C1611,C1612	CCCSL221J50
	C419,C420	CCCSL560K500
	C421,C422	CCMSL100D50
	C343	CEANP100M50
	C341	CEANP220M50
	C345	CEANP470M50
	C473,C474	CEASR22M50

Mark	Symbol & Description	Part No.
	C495	CEASR33M50
	C437-C440,C491,C492, C521-C524	CEAS010M50
	C313,C342,C344,C352,C471, C472,C493,C494,C496,C570 C475,C476	CEAS100M50
	C593	CEAS101M10
	C339,C340	CEAS101M16
	C304,C305	CEAS101M25
	C331,C332,C531,C532	CEAS102M25
	C307-C310,C478	CEAS2R2M50
	C351	CEAS220M25
	C303	CESA221M10
	C433,C434,C525,C526	CEAS222M25
	C591	CEAS330M16
	C435,C436	CEAS4R7M50
	C545,C546,C581	CEAS470M10
	C335,C337,C338	CEAS470M16
	C336	CEAS470M25
	C541,C542	CEHAQ470M25
	C527,C528	CFTXA333J50
	C347-C350	CFTXA683J50
	C316	CKCYX104M25
	C346	CKDYB392K500
	C587	CKDYF473Z50
	C411,C412	CKMYB221K50
	C413,C414	CKMYB331K50
	C533,C534,C586	CKMYB471K50
	C415,C416	CKMYB681K50
	C582,C584	CKMYB821K50
	C585	CQMA103K50
	C583	CQMA123K250
	C529,C530	CQMA153K50
	C535,C536	CQMA182J50
	C539,C540	CQMA183J50
	C590	CQMA562J50
	C431,C432	CQMA562K400
	C537,C538	CQMA682J50
		CQMA752J50

RESISTORS

Mark	Symbol & Description	Part No.
	R307,R308	RS2LMFR22J
	R364	RS2LMF681J
	VR451,VR452 (100k)	VRTM6H104
	VR453,VR454 (20k)	VRTM6H203
	VR521,VR522 (20k)	VRTM6V203

Mark	Symbol & Description	Part No.
	VR411,VR412 (200k) R590 R341,R342,R345,R350-R352 R301-R305,R337-R340,R343, R344,R348,R349	VRTM6V204 RD1/2PM180J RD1/4PMFL□□□J RD1/4PM□□□J
	Other resistors	RD1/8PM□□□J

OTHERS

Mark	Symbol & Description	Part No.
	4P Speaker terminal DC jack	AKE1012 AKN-203

**MAIN VR assembly
SEMICONDUCTORS**

Mark	Symbol & Description	Part No.
	IC391	NJM4558DXP
	Q393 Q391,Q392	2SA1048 2SC2878

COILS

Mark	Symbol & Description	Part No.
	L391,L392 Axial Inductor (5.6μH)	LAU5R6K

CAPACITORS

Mark	Symbol & Description	Part No.
	C393,C394 C391,C392 C397,C398 C395,C396	CCMSL101J50 CEAS4R7M50 CEAS470M10 CKCYF473Z50

RESISTORS

Mark	Symbol & Description	Part No.
	VR391 (100k × 2) Other resistors	ACX1021 RD1/8PM□□□J

**HEAD PHONE assembly
CAPACITORS**

Mark	Symbol & Description	Part No.
	C401	CKCYF473Z50

RESISTORS

Mark	Symbol & Description	Part No.
	R402-R405 R401	RD1/2PMF681J RD1/8PM100J

OTHERS

Mark	Symbol & Description	Part No.
	Head phone Jack	AKN1010

TRANS CONNECT assembly

No parts are supplied with the TRANS CONNECT assembly.

**AMP,GEQ CTRL assembly (AWZ2218)
SEMICONDUCTORS**

Mark	Symbol & Description	Part No.
	IC701 IC702 IC721,IC722	M74LS05P TC4081BP BA3812L
	Q701,Q702	DTA143ES
	D701-D705 LED D707,D708	AEL1065 HSS104-02

SWITCHES

Mark	Symbol & Description	Part No.
	S701-S705	ASG1029

CAPACITORS

Mark	Symbol & Description	Part No.
	C743,C744 C727,C728 C723,C724 C741,C742,C747,C748 C749,C750	CCMSL101J50 CEASR15M50 CEASR68M50 CEAS100M25 CEAS470M16
	C733,C734 C729,C730 C739,C740 C735,C736 C725,C726	CKDYB182K50 CKDYB392K50 CKDYB682K50 CKDYX153M25 CKDYX183M25
	C721,C722 C731,C732 C745,C746 C737,C738	CKDYX393M25 CKDYX683M25 CKMYB331K50 CKMYB391K50

RESISTORS

Mark	Symbol & Description	Part No.
	VR721-VR725 (30k-B5 × 2) Other resistors	ACU1031 RD1/8PM□□□J

**DECK - 1 SW assembly
SWITCHES**

Mark	Symbol & Description	Part No.
	S811-S815 Tact switch (1FWD, 1REV, 1FF, 1REW, 1STOP)	ASG1029

**DECK - 2 SW assembly
SWITCHES**

Mark	Symbol & Description	Part No.
	S821-S825 Tact switch (2FWD, 2REV, 2FF, 2REW, 2STOP)	ASG1029

**DECK CTRL assembly (AWZ2219)
SEMICONDUCTORS**

Mark	Symbol & Description	Part No.
	IC802	M74LS42P
	IC801	PDE029-C
	Q814	DTC143ES
	Q803-806	RN1201
	Q801,802	RN2204
	Q807-812	2SA1515
	D801,D802,D808,D810-D815, D820-D824,D826,D834-D836	HSS104-02

COILS

Mark	Symbol & Description	Part No.
	X801 Ceramic resonator	ASS1018
	L801 Axial Inductor (22 μ H)	LAU220K

CAPACITORS

Mark	Symbol & Description	Part No.
	C801	CEASR33M50
	C803	CEAS101M10
	C802	CEAS101M16
	C839,C840	CKCYB102K50
	C804-C807	CKCYF473Z50

RESISTORS

Mark	Symbol & Description	Part No.
	VR803 (10k)	VRTM6H103
	VR801,VR802 (20k)	VRTM6H203
	Other resistors	RD1/8PM□□□J

**POWER SW assembly
SWITCH**

Mark	Symbol & Description	Part No.
	S707	ASG1029

**DECK CENTER assembly
SEMICONDUCTORS**

Mark	Symbol & Description	Part No.
	D845,D846LED	AEL1065
	D841-D844LED	AEK1076
	D847-D850	HSS104-02

SWITCHES

Mark	Symbol & Description	Part No.
	S841-S846 Tact switch	ASG1029
	S847,S848 Slide switche	ASH1014

RESISTORS

Mark	Symbol & Description	Part No.
	All resistors	RD1/8PM□□□J

**POWER SUPPLY assembly (AWZ2241)
SEMICONDUCTORS**

Mark	Symbol & Description	Part No.
	IC1002	NJM78M56FA
	IC1001	TC4069UBP
	Q1002	2SB560
	Q1003	2SC2240
	D1006,D1008,D1011-D1013	HSS104-02
	D1004 Zener Diode	RD33ESB2
	D1009 Zener Diode	RD5.1ESB
	D1001,D1003,D1005,D1007, D1014	S5566

TRANSFORMER

Mark	Symbol & Description	Part No.
△	T1001 Power transformer	ATT1092

RELAY

Mark	Symbol & Description	Part No.
△	RY1001 Relay	ASR1024

CAPACITORS

Mark	Symbol & Description	Part No.
	C1009,C1010	CEAS100M50
	C1005	CEHAQ220M50
	C1004	CEAS221M50
	C1007	CEAS222M16
	C1011	CEAS4R7M50
	C1008	CEAS470M16
	C1006	CEAS470M50
	C1001	CEAS470M63

RESISTORS

Mark	Symbol & Description	Part No.
	R1011	RD1/4PMFL4R7J
	R1003	RS2LMF222J
	R1005	RS2LMF821J
	Other resistors	RD1/8PM□□□J

OTHERS

Mark	Symbol & Description	Part No.
⚠	1P AC SOCKET (OUTLET)	AKP1035

CONNECT assembly

No parts are supplied with the connection assembly.

6. ADJUSTMENTS

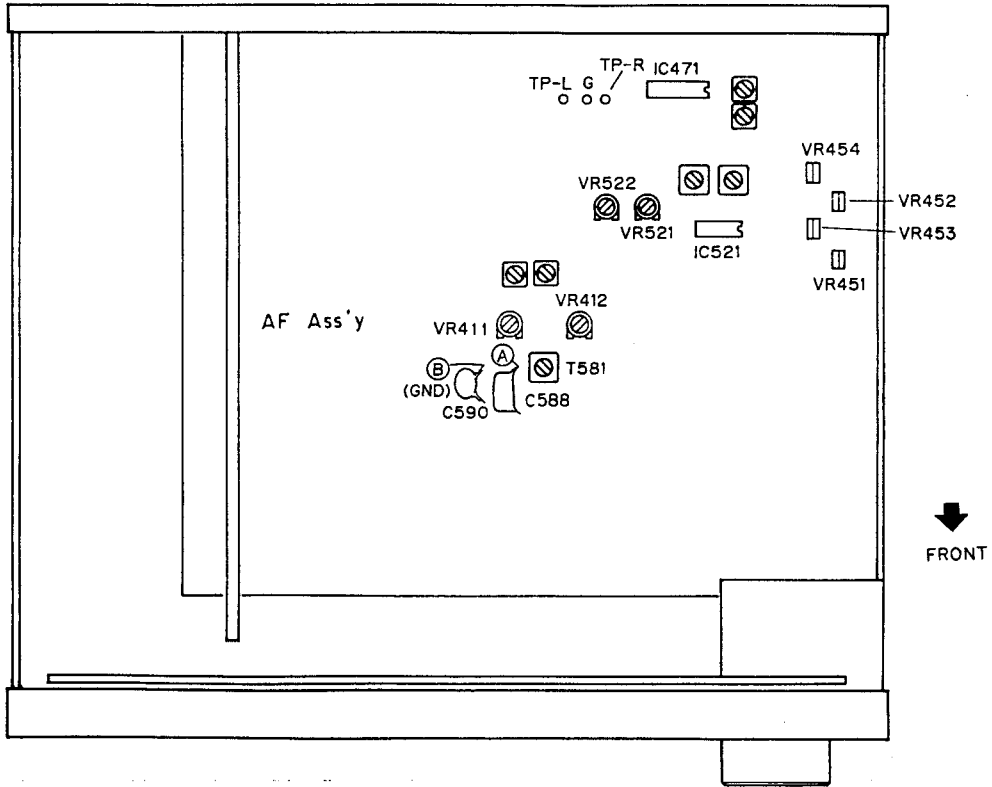

Fig 6.1. Adjustment location

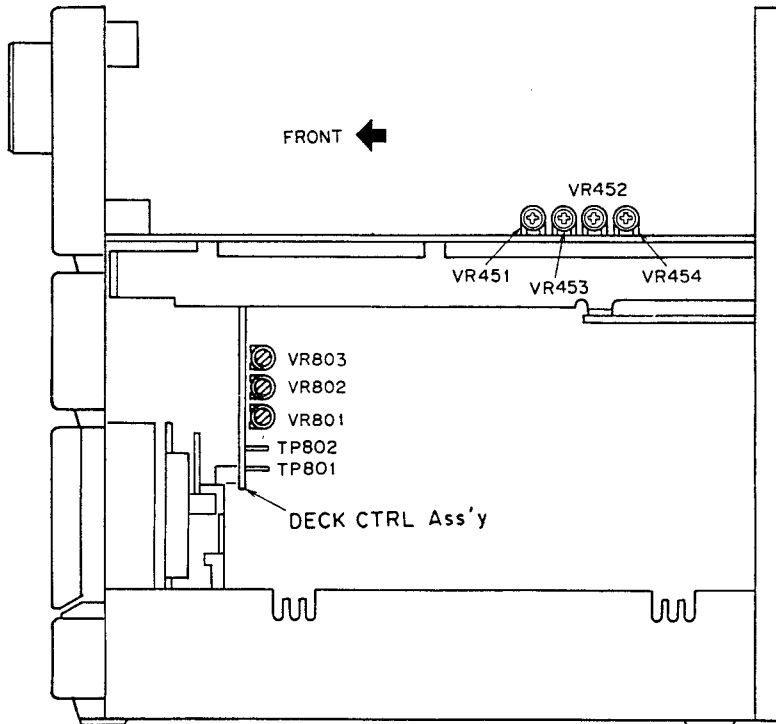

Fig 6.2. Adjustment location

- Adjustment and measurement are usually made in the AF Ass'y, unless specified otherwise.
- Set the graphic equalizer to FLAT. Depending on the country of destination, the unit may be equipped with a MIC mixing volume control.
If a MIC mixing volume control is built in, please set to the MIN position.
- The function should always be set to "TAPE" unless otherwise specified.

Adjustment of Mechanical System

- Test tape: STD-301 (3 kHz, 30 min.)
- Setting of double speed mode: Short-circuit TP801 and TP802 of the Control Ass'y. To release the mode, break the short circuit.

1. Adjustment of tape speed							
No.	Mode	Input signal & Test tape	Adjustment location		Measuring location	Adjustment value	Remarks
1	PLAY	Playback the STD-301 tape to 3 kHz.	Deck I	DECK CTRL Ass'y VR801	TP-L (Lch)	Press the PLAY SW and adjust the frequency to 3010 Hz \pm 10 Hz. Make sure that the wow and flutter is within 0.2 %.	
2	PLAY (Double speed mode)			---		Press the PLAY SW in double speed mode and confirm that the frequency is 6000 Hz \pm 1000 Hz. Note down the figure.	Release the double speed mode after adjustment.
3	PLAY (Double speed mode)		Deck II	DECK CTRL Ass'y VR803	TP-R (Rch)	Press the PLAY SW in double speed mode and adjust the frequency to be within \pm 30 Hz of the figure recorded at step No. 2.	Release the double speed mode after adjustment.
4	PLAY			DECK CTRL Ass'y VR802		Press the PLAY SW and adjust the frequency to 3010 Hz \pm 10 Hz. Make sure that the wow and flutter is within 0.2 %.	

Adjustment of Electric System

■ Check and conduct the following before adjusting the electric system.

1. Adjustment of tape speed has been completed.
2. Clean and demagnetize the head using a head eraser.
3. When measured, the level should be 0 dBV = 1 Vrms.
4. Use side A of the specified tape for adjustment.
STD-331B: For adjustment of playback system.
STD-630: NORMAL blank tape
STD-620: CrO₂ blank tape
STD-610: METAL blank tape
5. Prepare the following measuring devices:
AC millivoltmeter, Low-frequency oscillator, Attenuator, Oscilloscope
6. Adjust both L and R channels, unless specified otherwise.
7. Set the DOLBY NR switches to OFF, unless specified otherwise.
8. Warm up the unit for several minutes before adjustment. Especially before adjusting the frequency characteristics of recording and playback, warm up for 3 to 5 minutes in REC/PLAY mode.
9. Make sure to follow the proper order of the adjustment procedure. Any change in the order may cause an imperfect result.

List of Adjustment

Deck I

1. Head azimuth adjustment
2. Playback level adjustment

Deck II

1. Head azimuth adjustment
2. Playback level adjustment
3. Adjustment frequency characteristics of recording/playback
4. Recording level adjustment

Checking of Decks II

1. Make sure the ALC is operating properly.

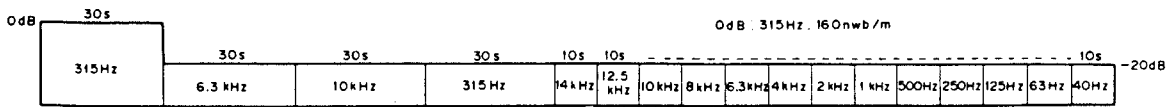

Fig. 6.3 Test tape STD-331B

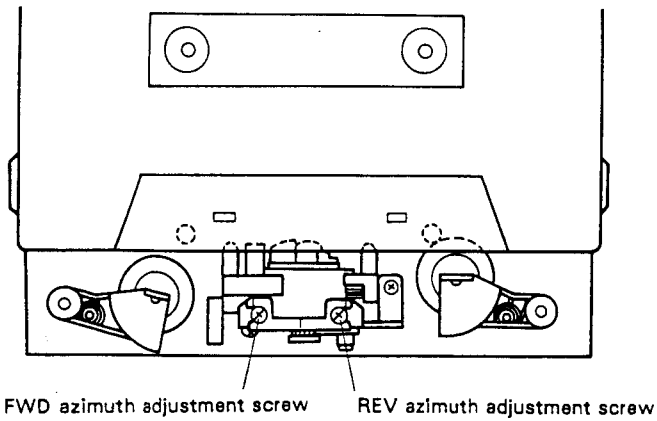

Fig. 6.4 Head azimuth adjustment

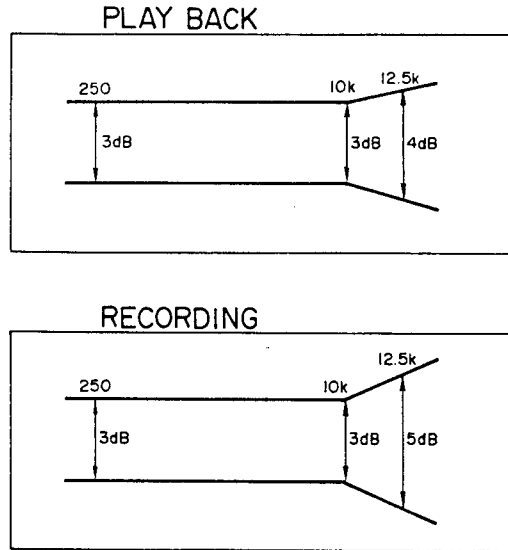

Fig. 6.5 Frequency characteristics

• Head Adjustment of Deck I

- Deck I is provided with an automatic tape selector mechanism.
- Note: Do not switch over FWD and REV while the driver is inserted.

1. Head Azimuth Adjustment

Pro-cedure	Tape selector	Mode	Input signal/test tape	Adjustment location	Measuring location	Adjustment value	Remarks
1	NORM	PLAY	Playback the test tape STD-331B (10 kHz, -20 dB).	Head azimuth adjustment screw (Fig. 6-4)	TP-L (Lch) TP-R (Rch)	Maximum playback signal level	Lock the screw with screw lock after completing adjustment.

2. Playback Level Adjustment

- Be sure to make a careful adjustment, as the adjustment determines the DOLBY NR level for playback.

Pro-cedure	Tape selector	Mode	Input signal/test tape	Adjustment location	Measuring location	Adjustment value	Remarks
1	NORM	PLAY	Playback the test tape STD-331B (315 Hz, 0 dB).	VR453 (Lch) VR454 (Rch)	TP-L (Lch) TP-R (Rch)	-6.7 dBV	

• Head Adjustment of Deck II

- Deck II is provided with an automatic tape selector mechanism.
- Note: Do not switch over FWD and REV while the driver is inserted.

1. Head Azimuth Adjustment

Pro-cedure	Tape selector	Mode	Input signal/test tape	Adjustment location	Measuring location	Adjustment value	Remarks
1	NORM	PLAY	Playback the test tape STD-331B (10 kHz, -20 dB).	Head azimuth adjustment screw (Fig. 6-4)	TP-L (Lch) TP-R (Rch)	Maximum playback signal level	Lock the screw with screw lock after completing adjustment.

2. Playback Level Adjustment

- Be sure to make a careful adjustment, as the adjustment determines the DOLBY NR level for playback.

Pro-cedure	Tape selector	Mode	Input signal/test tape	Adjustment location	Measuring location	Adjustment value	Remarks
1	NORM	PLAY	Playback the test tape STD-331B (315 Hz, 0 dB).	VR451 (Lch) VR452 (Rch)	TP-L (Lch) TP-R (Rch)	-6.7 dBV	

3. Adjustment of frequency characteristics of recording/playback

- As this procedure is for adjustment of the recording bias, be careful not to increase the distortion rate by under-adjusting the bias.

Pro-cedure	Tape selector	Mode	Input signal/test tape	Adjustment location	Measuring location	Adjustment value	Remarks
1	NORM	REC	Load the test tape STD-630 and set to record mode.	—	Area between Ⓐ and Ⓑ (A F Ass'y) shown in Fig. 6-1.	Confirm that the oscillation frequency is 105 kHz \pm 1 kHz.	If the adjustment value cannot be set within the specification, adjust the T581.
2	NORM	REC	Apply a signal of 315 Hz to the CD input terminal and set the function to "CD".	Input signal level	TP-L (Lch) TP-R (Rch)	-27.7 dBV	
3	NORM	REC/ PLAY	Record and playback the test tape STD-630 (315 Hz and 10 kHz).	VR411 (Lch) VR412 (Rch)	TP-L (Lch) TP-R (Rch)	Repeat the correction so that the playback level of 10 kHz remains 0 \pm 0.5 dB in relation to 315 Hz.	

4. Recording Level Adjustment

Pro-cedure	Tape selector	Mode	Input signal/test tape	Adjustment location	Measuring location	Adjustment value	Remarks
1	NORM	REC	Apply a signal of 315 Hz to the CD input terminal and set the function to "CD".	Input signal level	TP-L (Lch) TP-R (Rch)	-7.7 dBV	
2	NORM	REC/ PLAY	Record and playback the test tape STD-630 (315 Hz).	VR521 (Lch) VR522 (Rch)	TP-L (Lch) TP-R (Rch)	Repeat the recording and correction so that the playback level of 315 Hz is -6.7 dBV.	

• Checking Procedure for Deck II

1. Action of ALC

Pro-cedure	Tape selector	Mode	Input signal/test tape	Adjustment location	Measuring location	Checking value	Remarks
1	NORM	REC	Apply a signal of 315 Hz to the CD input terminal and set the function to "CD".	Input signal level	TP-L (Lch) TP-R (Rch)	-7.7 dBV	
2				+10 dB against the input level of step 1.		-2.7 dBV \pm 2.5 dB	

6. RÉGLAGES

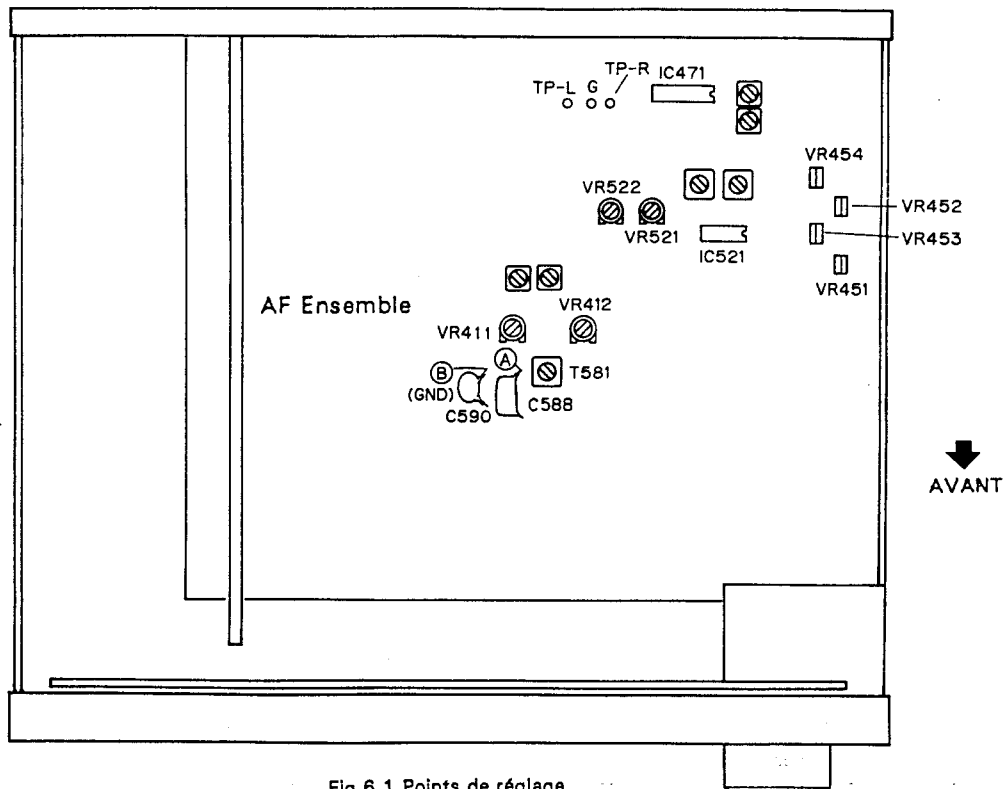

Fig 6.1 Points de réglage

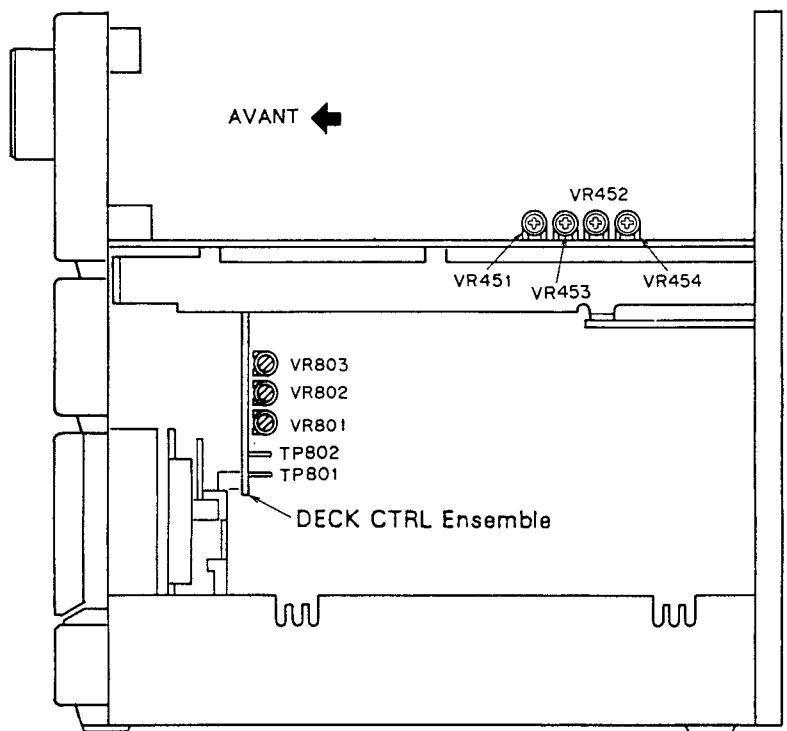

Fig 6.2 Points de réglage

- Les réglages et les mesures sont généralement faits dans l'ensemble AF, à moins de spécification contraire.
- Régler l'égaliseur graphique sur FLAT, selon le pays de destination, l'unité peut être équipée d'une commande de volume de mixage de micro.
Si une commande de volume de mixage de micro est incorporée, prière de la régler à la position minimum.
- La fonction doit toujours être réglée sur "TAPE" à moins de spécification contraire.

Réglages mécaniques

- Bande d'étalonnage: STD-301 (3 kHz, 30 mn.)
- Réglage du mode de vitesse double: Court-circuiter TP801 et TP802 de l'ensemble de commande. Pour libérer le mode, ouvrir le court-circuit.

1. Réglage de la vitesse de bande							
No.	Mode	Signal appliqué / bande d'étalonnage	Emplacement du réglage		Emplacement du point de mesure	Valeur relevée	Observations
1	PLAY	Reproduire la bande STD-301 par 3 kHz.	Platine I	ENSEMBLE COMM. PLATINE VR801	TP-L (can. G)	Appuyer sur le contacteur PLAY et régler la fréquence sur 3.010 Hz \pm 10 Hz. Vérifier que le pleurage et scintillement est dans la limite de 0,2%.	
2	PLAY (Mode de vitesse double)			—		Appuyer sur le contacteur PLAY dans le mode de vitesse double et vérifier que la fréquence est 6.000 Hz \pm 1.000 Hz. Noter le chiffre.	Libérer le mode de vitesse double après le réglage.
3	PLAY (Mode de vitesse double)		Platine II	ENSEMBLE COMM. PLATINE VR803	TP-R (can. D)	Appuyer sur le contacteur PLAY dans le mode de vitesse double et régler la fréquence pour qu'elle soit dans la limite de \pm 30 Hz du chiffre noté dans l'étape No. 2.	Libérer le mode de vitesse double après le réglage.
4	PLAY			ENSEMBLE COMM. PLATINE VR802		Appuyer sur le contacteur PLAY et régler la fréquence sur 3.010 Hz \pm 10 Hz. Vérifier que le pleurage et scintillement est dans la limite de 0,2%.	

Réglages électriques

■ Vérifier les points suivants et effectuer les opérations suivantes avant procéder aux réglages électriques.

1. Le réglage de la vitesse de bande a été complété.
2. Nettoyer et démagnétiser la tête avec un démagnétiseur de tête.
3. Lors de la mesure, le niveau doit être de 0 dBV = 1 Vepp.
4. Utiliser la face A de la bande spécifiée pour le réglage. STD-331B: Pour le réglage du système de lecture.
STD-630: Bande vierge NORMAL
STD-620: Bande vierge CrO₂
STD-610: Bande vierge METAL
5. Préparer les instruments de mesure suivants:
Millivoltmètre CA, oscillateur à basse fréquence, éatténateur et oscilloscope.
6. Régler les deux canaux L (gauche) et R (droit), sauf spécification contraire.
7. Régler les commutateurs DOLBY NR sur la position OFF, sauf spécification contraire.
8. Laisser chauffer l'appareil pendant plusieurs minutes avant le réglage. En particulier avant d'effectuer le réglage de la réponse en fréquence d'enregistrement et de lecture, laisser chauffer l'appareil pendant 3 à 5 minutes dans le mode d'enregistrement/lecture (REC/PLAY).
9. Toujours suivre l'ordre spécifié de la méthode réglage. Tout changement de l'ordre peut provoquer des résultats imparfaits.

Liste des réglages

Platine I

1. Azimut de la tête
2. Niveau de lecture

Platine II

1. Azimut de la tête
2. Niveau de lecture
3. Réponse en fréquence d'enregistrement/lecture
4. Niveau d'enregistrement

Vérification de la Platines II

1. Vérifier que le ALC fonctionne correctement.

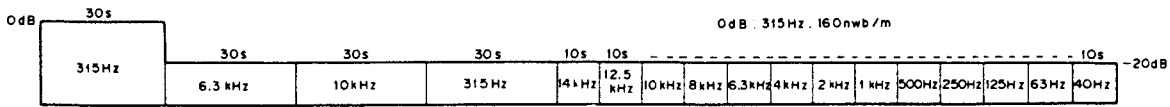

Fig. 6.3 Bande d'étalonnage STD-331B

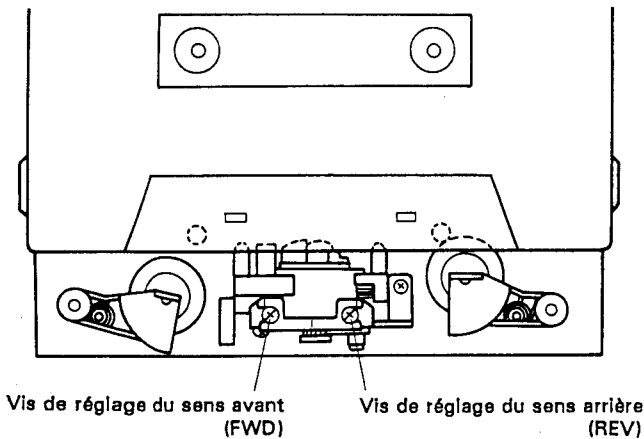
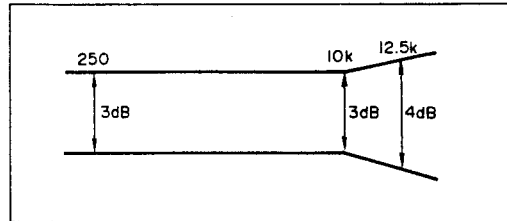

Fig. 6.4 Réglage d'azimut de la tête

LECTURE



ENREGISTREMENT

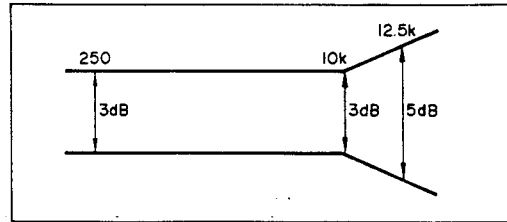

Fig. 6.5 Réponse en fréquence

• Réglage de la Platine I

- La Platine I est équipée d'un mécanisme de sélection automatique de bande.
- Remarque: Ne pas commuter entre le sens avant (FWD) et le sens arrière (REV) pendant que le tournevis est inséré.

1. Réglage d'azimut de la tête

Opération	Sélecteur de bande	Mode	Signal appliqué / bande d'étalonnage	Emplacement du réglage	Emplacement du point de mesure	Valeur relevée	Observations
1	NORM	PLAY	Reproduire la bande d'étalonnage STD-331B (10 kHz, -20 dB).	Vis de réglage d'azimut de tête (Fig. 6-4)	TP-L (can. G) TP-R (can. D)	Niveau maximum du signal de lecture	Une fois le réglage terminé, bloquer la vis avec un frein de vis.

2. Réglage du niveau de lecture

- Toujours effectuer un réglage minutieux, car la valeur réglée sera le niveau Dolby pour la lecture.

Opération	Sélecteur de bande	Mode	Signal appliqué / bande d'étalonnage	Emplacement du réglage	Emplacement du point de mesure	Valeur relevée	Observations
1	NORM	PLAY	Reproduire la bande d'étalonnage STD-331B (315 kHz, 0 dB)	VR453 (can. G) VR454 (can. D)	TP-L (can. G) TP-R (can. D)	-6,7 dBV	

• Réglage de la Platine II

- La Platine II est équipée d'un mécanisme de sélection automatique de bande.
- Remarque: Ne pas commuter entre le sens avant (FWD) et le sens arrière (REV) pendant que le tournevis est inséré.

1. Réglage d'azimut de la tête

Opération	Sélecteur de bande	Mode	Signal appliqué / bande d'étalonnage	Emplacement du réglage	Emplacement du point de mesure	Valeur relevée	Observations
1	NORM	PLAY	Reproduire la bande d'étalonnage STD-331B (10 kHz, -20 dB).	Vis de réglage d'azimut de tête (Fig. 6-4)	TP-L (can. G) TP-R (can. D)	Niveau maximum du signal de lecture	Une fois le réglage terminé, bloquer la vis avec un frein de vis.

2. Réglage du niveau de lecture

- Toujours effectuer un réglage minutieux, car la valeur réglée sera le niveau Dolby pour la lecture.

Opération	Sélecteur de bande	Mode	Signal appliqué / bande d'étalonnage	Emplacement du réglage	Emplacement du point de mesure	Valeur relevée	Observations
1	NORM	PLAY	Reproduire la bande d'étalonnage STD-331B (315 kHz, 0 dB)	VR451 (can. G) VR452 (can. D)	TP-L (can. G) TP-R (can. D)	-6,7 dBV	

3. Réglage de la réponse fréquence d'enregistrement/lecture

- Cette opération réglant la polarisation d'enregistrement, faire attention de ne pas augmenter la distorsion par un réglage insuffisant de la polarisation.

Procédure	Sélecteur de bande	Mode	Signal appliqué / bande d'étalonnage	Emplacement du réglage	Emplacement du point de mesure	Valeur relevée	Observations
1	NORM	REC	Charger la bande d'étalonnage STD-630 et régler dans le mode d'enregistrement.	—	Partie entre ① et ② (ensemble d'enregistrement (A.F)) indiquée sur la Fig. 6-1.	Vérifier que la fréquence d'oscillation est de 105 kHz \pm 1 kHz.	Si la valeur de mesurée ne peut pas être réglée dans les limites spécifiées, régler T581.
2	NORM	REC	Appliquer un signal de 315 Hz à la borne d'entrée CD et régler la fonction sur "CD".	Niveau du signal d'entrée	TP-L (can. G) TP-R (can. D)	-27,7 dBV	
3	NORM	REC / PLAY	Enregistrer et reproduire la bande d'étalonnage STD-630 (315 Hz et 10 kHz).	VR411 (can. G) VR412 (can. D)	TP-L (can. G) TP-R (can. D)	Répéter la correction de sorte que le niveau de lecture de 10 kHz soit de 0 \pm 0,5 dB en relation avec 315 Hz.	

4. Réglage du niveau d'enregistrement

Procédure	Sélecteur de bande	Mode	Signal d'entrée / bande d'essai	Emplacement du réglage	Emplacement du point de mesure	Valeur relevée	Remarques
1	NORM	REC	Appliquer un signal de 315 Hz à la borne d'entrée CD et régler la fonction sur "CD".	Niveau du signal d'entrée	TP-L (can. G) TP-R (can. D)	-7,7 dBV	
2	NORM	REC / PLAY	Enregistrer et reproduire la bande d'essai STD-630 (315 Hz).	VR521 (can. G) VR522 (can. D)	TP-L (can. G) TP-R (can. D)	Répéter l'enregistrement et la correction de sorte que le niveau de lecture de 315 Hz soit de -6,7 dBV.	

• Vérification de la Platine II

1. Action du ALC

Opération	Sélecteur de bande	Mode	Signal appliqué / bande d'étalonnage	Emplacement du réglage	Emplacement du point de mesure	Valeur relevée	Observations
1				Niveau du signal d'entrée		-7,7 dBV	
2	NORM	REC	Appliquer un signal de 315 Hz à la borne d'entrée CD et régler la fonction sur "CD".	+ 10 dB par rapport au niveau d'entrée de l'étape 1.	TP-L (can. G) TP-R (can. D)	-2,7 dBV \pm 2,5 dB	

6. AJUSTE

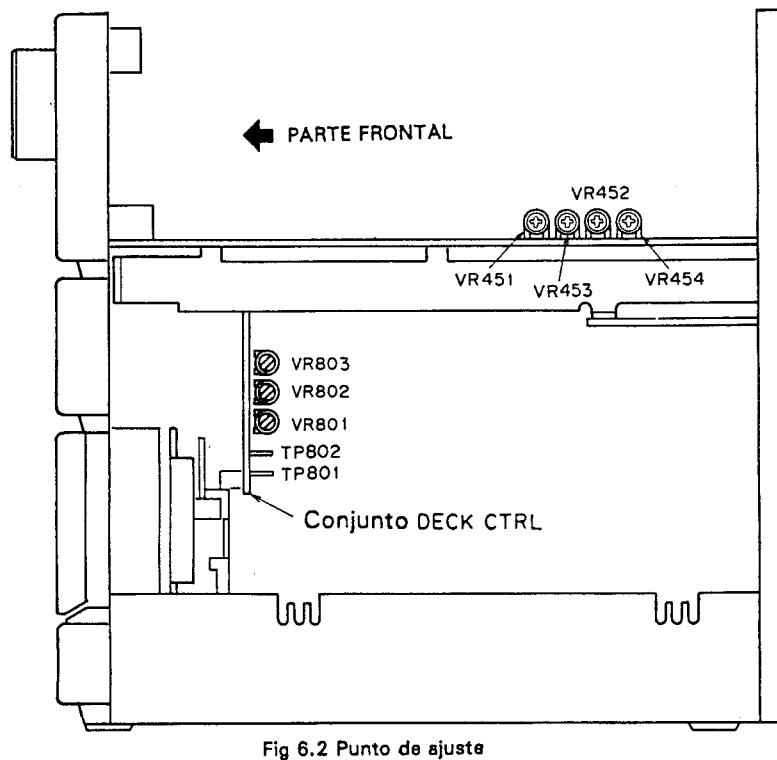
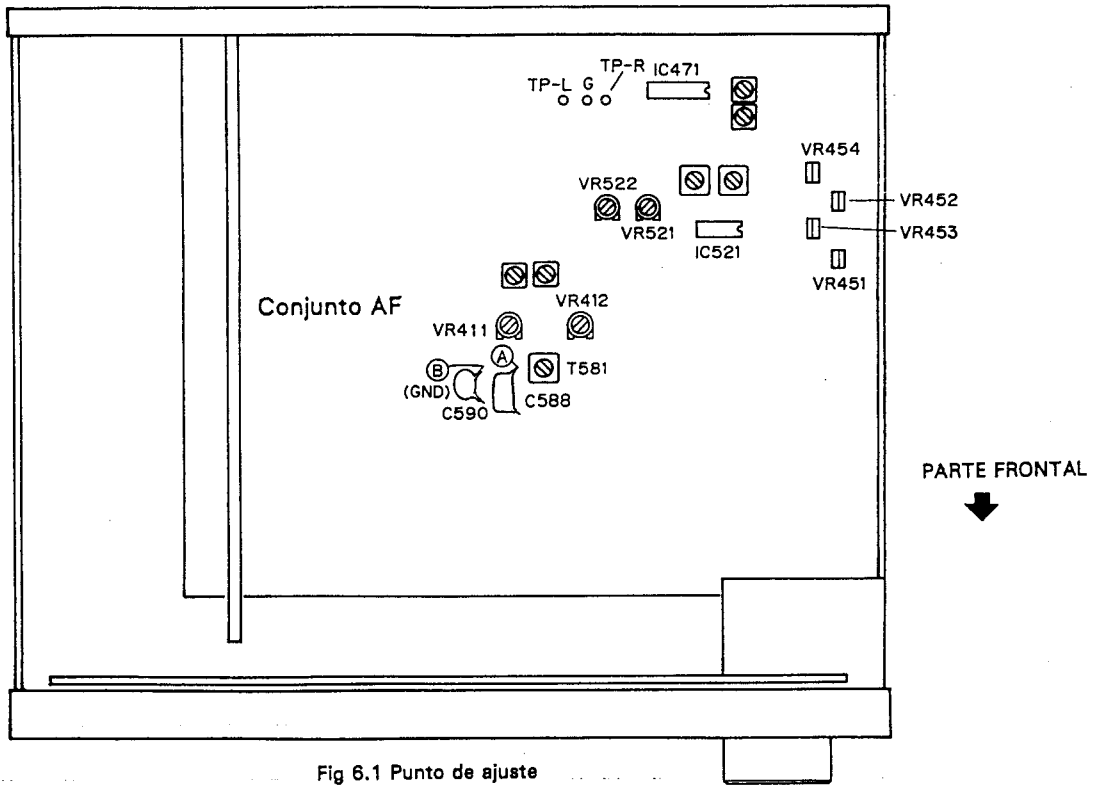

- El ajuste y la medición se realizarán normalmente en el conjunto AF, a menos que se especifique otra cosa.
- Desactive (FLAT) el ecualizador gráfico. Dependiendo del país de destino, el aparato puede estar provisto de un control de volumen de mezcla microfónica (MIC).
Se está provisto de un control de volumen de mezcla microfónica (MIC), ajústelo a la posición MIN.
- La función deberá estar ajustada siempre a "TAPE", a menos que se especifique otra cosa.

Ajuste del sistema mecánico

- Cinta de prueba: STD-301 (3 kHz, 30 min)
- Ajuste del modo de velocidad doble: Cortocircuite TP801 y TP802 del conjunto de control. Para desactivar el modo, abra el cortocircuito.

1. Ajuste de la velocidad de la cinta							
Nº	Modo	Señal de entrada/cinta de prueba	Punto de ajuste		Punto de medición	Valor de ajuste	Observaciones
1	PLAY	Reproducción de la cinta STDy301 a 3 kHz	Sección I	VR801 del conjunto DECK CTRL	TP-L (canal izquierdo)	Presione PLAY SW y ajuste la frecuencia a 3010 Hz \pm 10 Hz. Cerciórese de que la fluctuación y el efecto de trémolo estén dentro de los límites del 0,2%.	
2	PLAY (Modo de velocidad doble)			—		Presione PLAY SW en el modo de velocidad doble y compruebe si la frecuencia es 6000 Hz \pm 1000 Hz. Anote el valor.	Después del ajuste, desactive el modo de velocidad doble.
3	PLAY (Modo de velocidad doble)		Sección II	VR803 del conjunto DECK CTRL	TP-R (canal derecho)	Presione PLAY SW en el modo de velocidad doble y ajuste la frecuencia de forma que quede a \pm 30 Hz del valor anotado en el paso N°2.	Después del ajuste, desactive el modo de velocidad doble.
4	PLAY			VR802 del conjunto DECK CTRL		Presione PLAY SW y ajuste la frecuencia a 3010 Hz \pm 10 Hz. Cerciórese de que la fluctuación y el efecto de trémolo estén dentro de los límites del 0,2%.	

Ajuste del sistema eléctrico

■ Antes de ajustar el sistema eléctrico, compruebe y realice lo siguiente.

1. El ajuste de la velocidad de la cinta ha finalizado.
2. Limpie y desmagnetice la cabeza empleando un desmagnetizador de cabezas.
3. Cuando se mida, el nivel de nivel debe ser de 0 dBV = 1V rms.
4. Emplee el lado A de la cinta especificada para realizar el ajuste.
STD-331B: Para ajuste del sistema de reproducción.
STD-630: Cinta en blanco NORMAL
STD-620: Cinta en blanco de CrO2
SRD-610: Cinta en blanco de METAL
5. Prepare los dispositivos de medición siguientes:
Milivoltímetro de AC, oscilador de baja frecuencia, atenuador, y osciloscopio
6. Ajuste ambos canales, izquierdo y derecho, a menos que se especifique otra cosa.
7. Ponga los interruptores DOLBY NR en OFF, a menos que se especifique otra cosa.

8. Antes del ajuste, deje que la unidad se caliente durante varios minutos.
Especialmente antes de ajustar las características de frecuencia de grabación y reproducción, deje que se caliente durante 3 a 5 minutos en el modo REC/PLAY.
9. Cerciórese de seguir el orden apropiado del procedimiento de ajuste. Cualquier cambio en el orden podría causar un resultado imperfecto.

Lista de ajuste

Sección I

1. Azimut de la cabeza
2. Nivel de reproducción

Sección II

1. Azimut de la cabeza
2. Nivel de reproducción
3. Características de frecuencia de grabación/reproducción
4. Nivel de grabación

Comprobación de la secciones I y II

1. Cerciórese de que ALC esté funcionando adecuadamente.

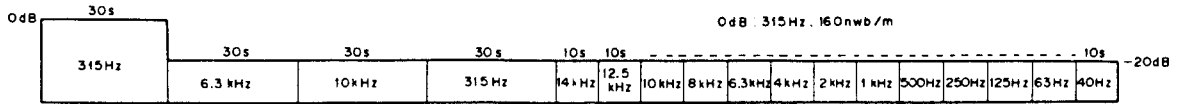

Fig. 6.3 Cinta de prueba STD-331B

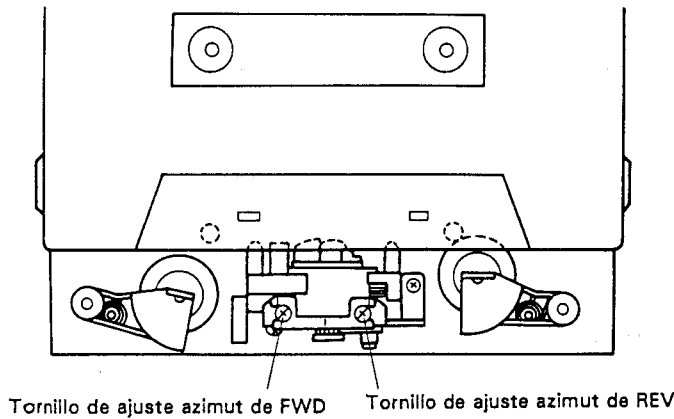
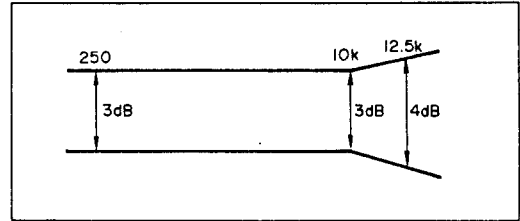

Fig. 6.4 Ajuste del azimut de la cabeza

REPRODUCCIÓN



CRABACIÓN

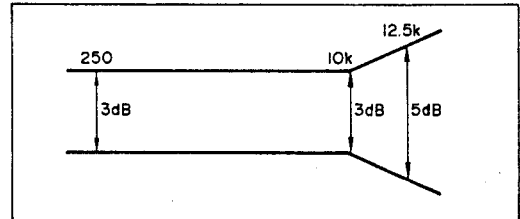

Fig. 6.5 Características de frecuencia

• Ajuste de la sección I

- La sección I dispone de un mecanismo selector automático de cinta.
- Nota: No cambie a FWD ni a REV mientras el destornillador esté insertado.

1. Ajuste azimutal de la cabeza

Procedimiento	Selector de cinta	Modo	Señal de entrada / cinta de prueba	Punto de ajuste	Punto de medición	Valor de ajuste	Observaciones
1	NORM	PLAY	Ponga la cinta de prueba STD-331B en reproducción (10 kHz, -20 dB).	Tornillo de ajuste azimutal de la cabeza (Fig. 6-4)	TP-L (canal izquierdo) TP-R (canal derecho)	Nivel máximo de la señal de reproducción	Bloquee el tornillo con bloqueador de tornillos después de haber terminado el ajuste.

2. Ajuste del nivel de reproducción

- Tenga mucho cuidado durante el ajuste, ya que el valor ajustado será el nivel Dolby fijado para reproducción.

Procedimiento	Selector de cinta	Modo	Señal de entrada / cinta de prueba	Punto de ajuste	Punto de medición	Valor de ajuste	Observaciones
1	NORM	PLAY	Ponga la cinta de prueba STD-331B en reproducción (315 Hz, 0 dB).	VR453 (canal izquierdo) VR454 (canal derecho)	TP-L (canal izquierdo) TP-R (canal derecho)	-6,7 dBV	

• Ajuste de la sección II

- La sección II dispone de un mecanismo selector automático de cinta.
- Nota: No cambie a FWD ni a REV mientras el destornillador esté insertado.

1. Ajuste azimutal de la cabeza

Procedimiento	Selector de cinta	Modo	Señal de entrada / cinta de prueba	Punto de ajuste	Punto de medición	Valor de ajuste	Observaciones
1	NORM	PLAY	Ponga la cinta de prueba STD-331B en reproducción (10 kHz, -20 dB).	Tornillo de ajuste azimutal de la cabeza (Fig. 6-4)	TP-L (canal izquierdo) TP-R (canal derecho)	Nivel máximo de la señal de reproducción	Bloquee el tornillo con bloqueador de tornillos después de haber terminado el ajuste.

2. Ajuste del nivel de reproducción

- Tenga mucho cuidado durante el ajuste, ya que el valor ajustado será el nivel Dolby fijado para reproducción.

Procedimiento	Selector de cinta	Modo	Señal de entrada / cinta de prueba	Punto de ajuste	Punto de medición	Valor de ajuste	Observaciones
1	NORM	PLAY	Ponga la cinta de prueba STD-331B en reproducción (315 Hz, 0 dB).	VR451 (canal izquierdo) VR452 (canal derecho)	TP-L (canal izquierdo) TP-R (canal derecho)	-6,7 dBV	

3. Ajuste de las características de frecuencia de grabación/reproducción

- Como este procedimiento es para el ajuste de la polarización de grabación, tenga cuidado de no aumentar el valor de distorsión mediante el subajuste de la polarización.

Procedimiento	Selector de cinta	Modo	Señal de entrada / cinta de prueba	Punto de ajuste	Punto de medición	Valor de ajuste	Observaciones
1	NORM	REC	Cargue la cinta de prueba STD-630 y establezca el modo de grabación.	—	Área entre ① y ② (conjunto de A.F.) mostrada en la Fig. 6-1.	Confirme que la frecuencia de oscilación sea de 105 kHz \pm 1 kHz.	Si el valor de ajuste no puede establecerse dentro de la especificación, ajuste T1401 del conjunto de REC.
2	NORM	REC	Aplique una señal de 315 Hz al terminal de entrada CD y ajuste la función a "CD".	Nivel de la señal de entrada	TP-L (canal izquierdo) TP-R (canal derecho)	-27,7 dBV	
3	NORM	REC / PLAY	Grabe y reproduzca la cinta de prueba STD-630 (315 Hz y 10 kHz).	VR411 (canal izquierdo) VR412 (canal derecho)	TP-L (canal izquierdo) TP-R (canal derecho)	Repita la corrección de forma que el nivel de reproducción de 10 kHz sea de 0 \pm 0,5 dB en relación con 315 Hz.	

4. Ajuste del nivel de grabación

Procedimiento	Selector de cinta	Modo	Señal de entrada / cinta de prueba	Punto de ajuste	Punto de medición	Valor de ajuste	Observaciones
1	NORM	REC	Aplique una señal de 315 Hz al terminal de entrada CD y ajuste la función a "CD".	Nivel de la señal de entrada	TP-L (canal izquierdo) TP-R (canal derecho)	-7,7 dBV	
2	NORM	REC / PLAY	Grabe y reproduzca la cinta de prueba de forma que el nivel de reproducción de 315 Hz sea de -6,7 dBV.	VR521 (canal izquierdo) VR522 (canal derecho)	TP-L (canal izquierdo) TP-R (canal derecho)	Grabe y reproduzca la cinta de prueba de forma que el nivel de reproducción de 315 Hz sea de -6,7 dBV.	

• Procedimiento de comprobación para la secciones II

1. Acción del ALC

Procedimiento	Selector de cinta	Modo	Señal de entrada / cinta de prueba	Punto de ajuste	Punto de medición	Valor de ajuste	Observaciones
1	NORM	REC	Aplique una señal de 315 Hz al terminal de entrada CD y ajuste la función a "CD".	Nivel de la señal de entrada	TP-L (canal izquierdo) TP-R (canal derecho)	-7,7 dBV	
2				+10 dB contra el nivel de entrada del paso 1.		-2,7 dBV \pm 2,5 dB	

7. IC INFORMATION

● Terminal Function of PDE029-C (DECK & AMP control microcomputer)

Note: I: CMOS input, N: Nch open drain output,
O: CMOS output, UN: Nch open drain output with pull-up MOS transistor

No.	Terminal name	I/O	Function	Active																						
1	S1 (DATA1)	N	Used for sending/receiving of DATA with microcomputer of TUNER.	H/L																						
2	S0 (DATA2)	O		H/L																						
3	\overline{SC}	O		H/L																						
4	SREQ	O	Not used.	—																						
5	FADER (LED)	O	Not used.	—																						
6	1 BIAS	O	Not used.	—																						
7	2 BIAS	O	Oscillates BIAS only during REC mechanism 2.	H																						
8		I	Not used.	—																						
9	\overline{COPY}	UN	According to the various statuses in the table below, the control of the IC471 (for DOLBY NR) and for the switching inputs of the REC AMP are depicted as follows. DOLBY NR IC: IC471, HA12136 REC AMP Input Selector: IC521, TC4066BP	H/L																						
10	Dolby P/R	UN		<table border="1"> <thead> <tr> <th>FUNCTION</th> <th>REC MODE</th> <th>COPY (Pin 9)</th> <th>DOLBY P/R (Pin 10)</th> </tr> </thead> <tbody> <tr> <td rowspan="2">TAPE</td> <td>REC not operated.</td> <td>L</td> <td>L</td> </tr> <tr> <td>REC is operating.</td> <td>H</td> <td>L</td> </tr> <tr> <td rowspan="2">Except TAPE</td> <td>REC not operated.</td> <td>L</td> <td>L</td> </tr> <tr> <td>REC is operating.</td> <td>L</td> <td>H</td> </tr> <tr> <td></td> <td>COPY is operating (spin normal speed and double speed).</td> <td>L</td> <td>L</td> </tr> </tbody> </table>	FUNCTION	REC MODE	COPY (Pin 9)	DOLBY P/R (Pin 10)	TAPE	REC not operated.	L	L	REC is operating.	H	L	Except TAPE	REC not operated.	L	L	REC is operating.	L	H		COPY is operating (spin normal speed and double speed).	L	L
FUNCTION	REC MODE	COPY (Pin 9)	DOLBY P/R (Pin 10)																							
TAPE	REC not operated.	L	L																							
	REC is operating.	H	L																							
Except TAPE	REC not operated.	L	L																							
	REC is operating.	L	H																							
	COPY is operating (spin normal speed and double speed).	L	L																							
11	$\overline{PB1/2}$	UN	Control switching of playback mechanism (L: mechanism 1).	H/L																						
12	2.REC MUTE	UN	Sets to L only while mechanism 2 is in REC mode.	H																						
13	MS. PULSE	N	Not used.	—																						
14	1.REC MUTE	UN	Not used.	—																						
15	FADER	UN	Not used	—																						
16	PB. MUTE	UN	Turns OFF only during DECK playback mode.	H																						
17	1PULSE	N	Detects hall device pulse of mechanism 1.	H/L																						
18	2PULSE	N	Detects hall device pulse of mechanism 2.	H/L																						
19	$\overline{HI/NORM}$	N	Controls TAPE SPEED (H: double speed).	H/L																						
20	POW. RY	O	Becomes "H" when POWER is turned ON.	H																						
21	$\overline{1. MOTOR}$	N	Controls the motor of mechanism 1. (L: MOTOR rotates).	L																						
22	$\overline{P.ASES}$	N	Not used.	—																						

No.	Terminal name	I/O	Function	Active	
23	1. ●	N	Not used.	—	
24	2. MOTOR	N	Controls the motor of mechanism 2. (L : MOTOR rotates).	L	
25	DIGI ON/OFF	O	Not used.	—	
26	SP.RY	O	Controls SP RELAY(RY351) Operates MUTE for 5seconds after POWER is turned ON. Turns SP RELAY OFF immediately after POWER is turned OFF.	L	
27	V-UP	O	Controls TA7291S and UP/DOWN of the MOTOR VOLUME.	V-UP (Pin 27)	H
28	V-DOWN	O		V-DOWN (Pin 28)	H
29	L-MUTE	O	Operates MUTE for 0.5seconds when FUNCTION is switched and DIRECT is ON/OFF. When POWER is ON, the SP RELAY is turned ON, and it takes 0.3seconds until the output signal of VOLUME(VR391) functions for muting.	H	
30	TEST	—	Not used (GND).	—	
31	Vss	—	GND.	—	
32	OSC1	—	Connects 4.19MHz ceramic resonator.	—	
33	OSC2	—		—	
34	RES	—	RESET terminal.	L	
35	A	O	Transfer DATA of 3bit to the 74LS42P and uses as KEYSKAN OUT K00-K06.	L/H	
36	B	O		L/H	
37	C	O		L/H	
38	1. ► (LED)	N	Controls the FWD PLAY LED of mechanism 1.	L	
39	1. ◀ (LED)	N	Controls the REV PLAY LED of mechanism 1.	L	
40	2. ► (LED)	N	Controls the FWD PLAY LED of mechanism 2.	L	
41	2. ◀ (LED)	N	Controls the REV PLAY LED of mechanism 2.	L	
42	2. ● (LED)	N	Control the REC LED of mechanism 2.	L	
43	ASES(LED)	N	Controls the ASES LED.	L	
44	R.REC(LED)	N	Not used.	—	
45	R.ASES (LED)	N	Not used.	—	
46	SOL2B	O	Controls the solenoid for FF/REW of mechanism 2.	H	
47	SOL2A	O	Controls the solenoid for PLAY of mechanism 2.	H	
48	SOL1B	O	Controls the solenoid for FF/REW of mechanism 1.	H	
49	SOL1A	O	Controls the solenoid for PLAY of mechanism 1.	H	

No.	Terminal name	I/O	Function	Active
50 55	K10 K15	I	KEY matrix input.	H/L
56	K16	N		
57	K17			
58	SURROUND	UN	Controls SURROUND ON/OFF (for SD type only).	H
59	DIRECT	UN	Controls DIRECT ON/OFF.	—
60	F-MUTE	UN	Operates MUTE for 0.5seconds when FUNCTION is switched. When POWER is ON after SP RELAY(RY351) is activated (ON), MUTE is operated for 0.3seconds.	H
61	INH	UN	Switches FUNCTION.	H/L
62	B	UN		H/L
63	A	UN		H/L
64	VDD	—	+5V	—

8. FOR HE TYPE

8.1 CONTRAST OF MISCELLANEOUS PARTS

NOTES:

- Parts without part number cannot be supplied.
- The \triangle mark found on some component parts indicates the importance of the safety factor of the part. Therefore, when replacing, be sure to use parts of identical designation.
- Parts marked by "●" are not always kept in stock. Their delivery time may be longer than usual or they may be unavailable.

The DC-Z72/HE type is the same as the DC-Z72/HB type with the exception of the following sections.

Mark	Symbol & Description	Part No.		Remarks
		DC-Z72/HB type	DC-Z72/HE type	
	POWER SUPPLY assembly	AWZ2241	AWZ2239	
	CONNECT assembly	Non supply	Non supply	
\triangle	FU2001, FU2004, FU2005 Fuse(T1 . 25A/250V)	AEK-509	
\triangle	FU2001, FU2004, FU2005 Fuse(T1 . 25A/250V)	AEK-018	
\triangle	FU2003 Fuse(T800mA/250V)	AEK-507	AEK-031	
\triangle	AC Power cord	ADG-063	ADG-1021	
	Operating instruction(English)	ARB1154	
	Operating instruction(English, German, French, Italian, Dutch, Swedish, Spanish, Portuguese)	ARE1111	
	Operating instruction(German)	ARC1129	

8.2 POWER SUPPLY assembly(AWZ2239;HE TYPE)

The POWER SUPPLY assembly(AWZ2239;HE TYPE) is the same as the POWER SUPPLY assembly(AWZ2241;HB TYPE) With the exception of the following sections.

Mark	Symbol & Description	Part No.		Remarks
		AWZ2241;HB type	AWZ2239;HE type	
\triangle	AC socket(OUTLET)	AKP1035	AKP1034	

8.3 CONNECT assembly(HE TYPE)

The difference in parts between the CONNECT assemblies HB type and HE type is only the jumper wire.

8.4 SCHEMATIC AND P.C.BOARDS DIAGRAM

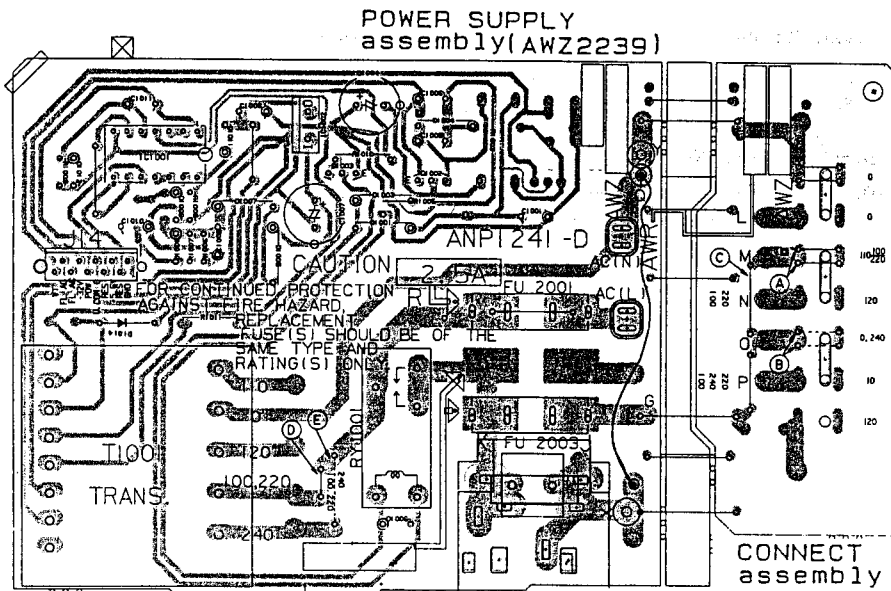
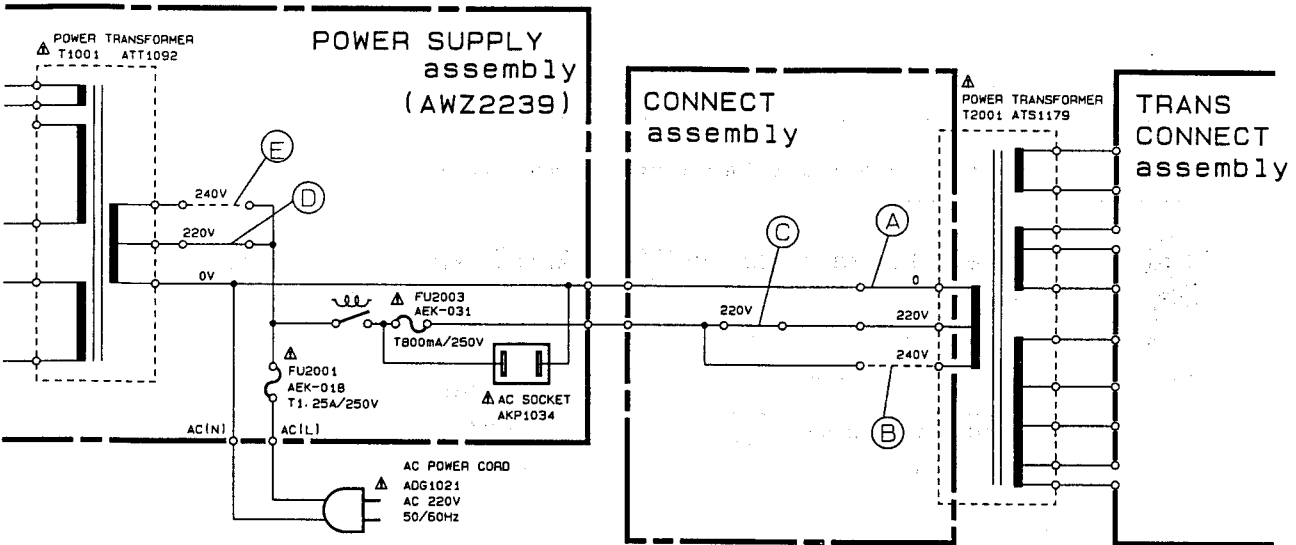

Line Voltage Selection (FOR HB AND HE TYPES)

Line voltage can be changed with the following steps.

1. Disconnect the AC power cord.
2. Remove the top cover.
3. Change the position of the jumper wires (A) - (E) as follows.

4. Stick the line voltage label on the rear panel.

Voltage	Jumper wire	
	220V	240V
(A)	○	×
(B)	×	○
(C)	○	×
(D)	○	×
(E)	×	○

○: Be needed
 ×: Be needless

Part No.	Description
AAX-193	220V label
AAX-192	240V label

9. CONNECTIONS

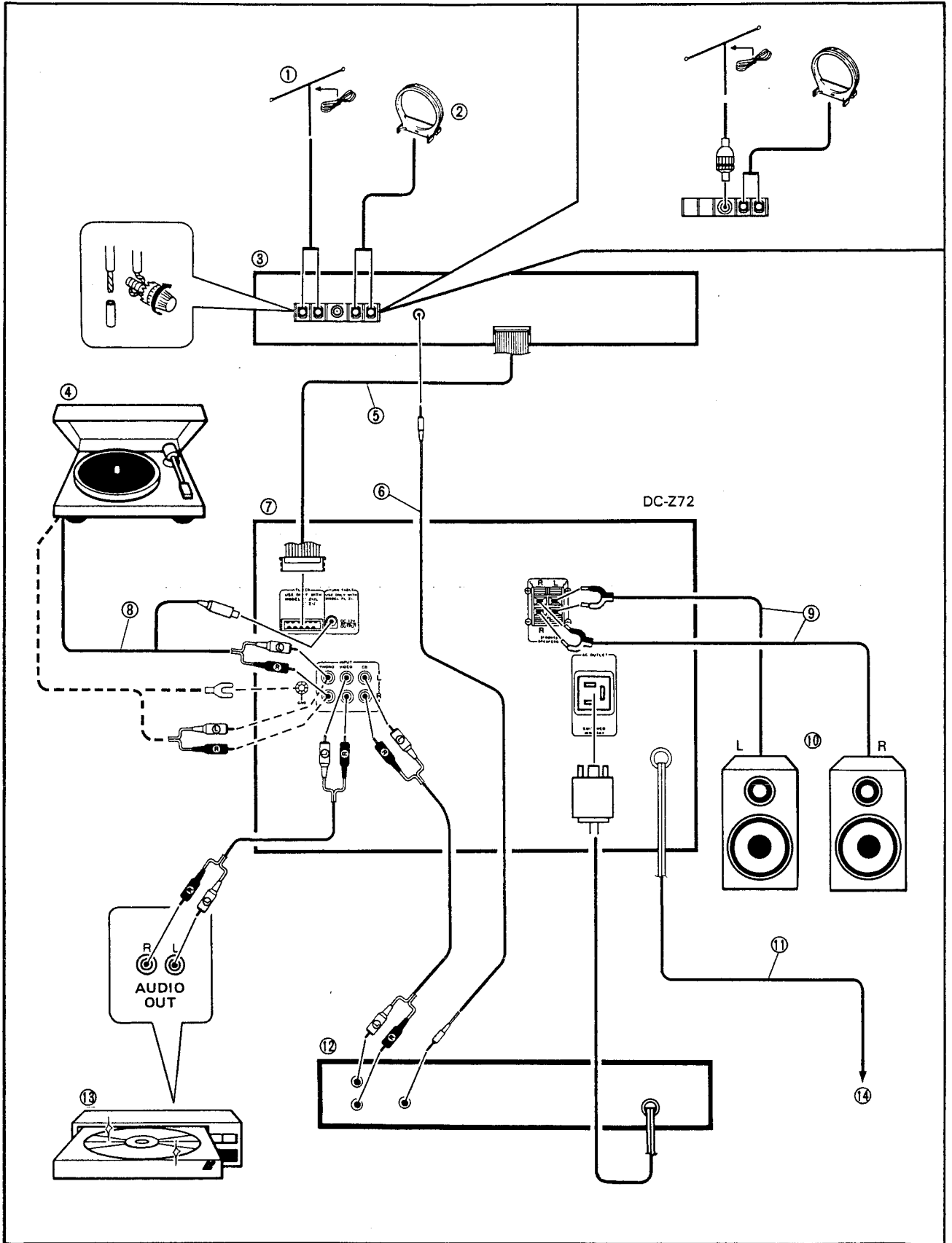

Refer to page 73 for the connections diagram.

- ① Accessory FM antenna
- ② Accessory AM loop antenna
- ③ FM/AM tuner (F-Z92 or F-Z92L)
- ④ Turntable (Separately sold PL-Z82 or PL-Z92)
- ⑤ Tuner input/output cord
- ⑥ CD player control cord
- ⑦ Cassette tape deck amplifier
- ⑧ Turntable output cord
- ⑨ Speakers cord
- ⑩ Speaker system
- ⑪ Power cord
- ⑫ CD player (Separately sold PD-Z72T or PD-Z82M)
- ⑬ LD player or video cassette recorder (VCR)
- ⑭ AC wall socket

Plug the power cord into the AC wall socket outlet only after all the connections have been completed.

If the FM antenna of the FM/AM tuner terminal is a PAL connector only, then refer to connection diagram B.

Proceed as follows with the set-up and connections:

1. Place the cassette tape deck amplifier on top of the CD player.
2. Connect the CD player OUTPUT jacks to the cassette tape deck amplifier CD INPUT jacks with audio cords.
3. Place the tuner on top of the cassette tape deck amplifier.
4. Connect the tuner input/output cord ⑤ to cassette tape deck amplifier.

TUNER CONNECTION

Insert the connector until it locks, thus ensuring that it is connected. When disconnecting the connector, pull it in the opposite direction while pressing the left and right claws.

If using this unit together with the optional PD-Z72T or PD-Z82M, connect the control cord ⑥.

5. Connect the FM antenna ① and the AM loop antenna ② to the tuner antenna terminals.
6. Place the turntable on top of the tuner.
7. Connect the turntable cords ⑧ to the cassette tape deck amplifier jacks.
If using this unit together with the optional PL-Z82 or PL-Z92, connect the turntable's audio cords and power supply cord respectively to the cassette tape deck amplifier's PHONO jacks and DC 12V OUTPUT jack.
If using a different turntable, connect the audio cord and earth cord.
8. Use the "VIDEO" jacks for connection to the audio jacks of an LD player or VCR.

NOTE:

- Insert the plugs securely into the jacks. Improper connection can lead to sound distortion or malfunctioning.
- The white plug is for the left channel connection and the red plug for the right channel connection.

9. Connect the speaker cords ⑨ to the SPEAKERS terminals.
Connect the "+" terminals on the cassette tape deck amplifier to the "+" terminals on the speakers, the "-" terminals on the cassette tape deck amplifier to the "-" terminals on the speakers.

Connecting the speaker cords.

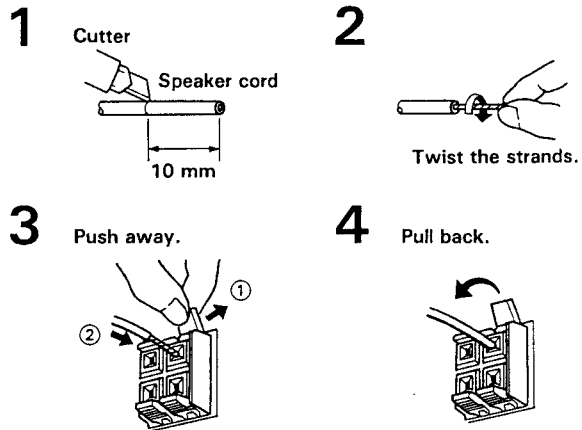

NOTE:

Do not allow the conductors of the cords to project beyond the terminals and to come into contact with other conductors. A breakdown or failure may occur when conductors touch one another.

Speaker impedance

Connect speaker systems with a nominal impedance ranging from 6 to 16 Ω.

10. Finally, connect the power cord ⑪ to the AC wall socket ⑭.

10. PANEL FACILITIES

DC-Z72

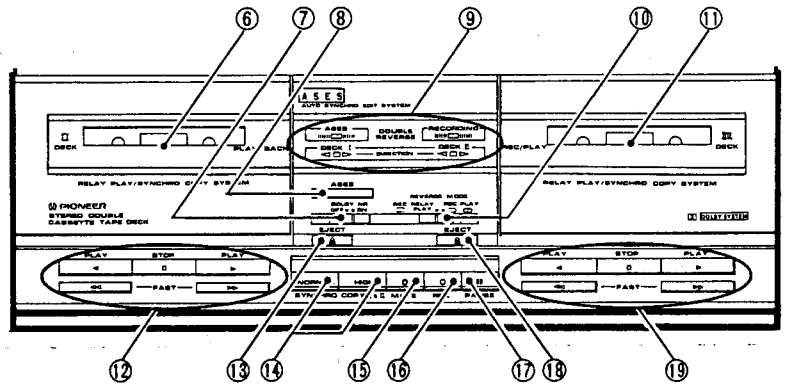
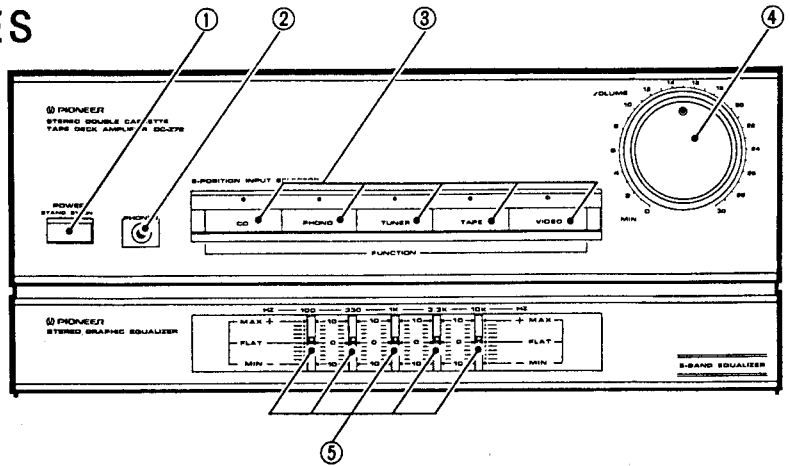
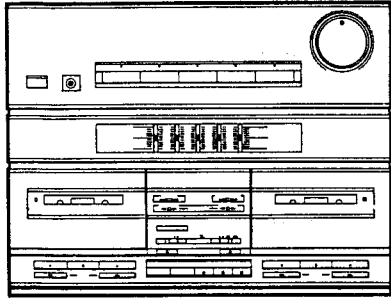

DC-Z72

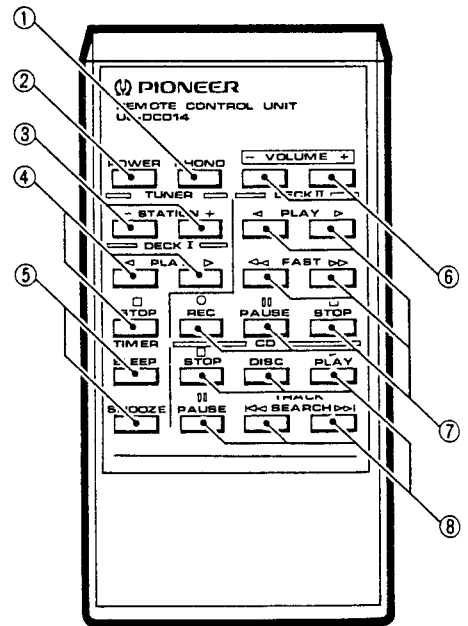
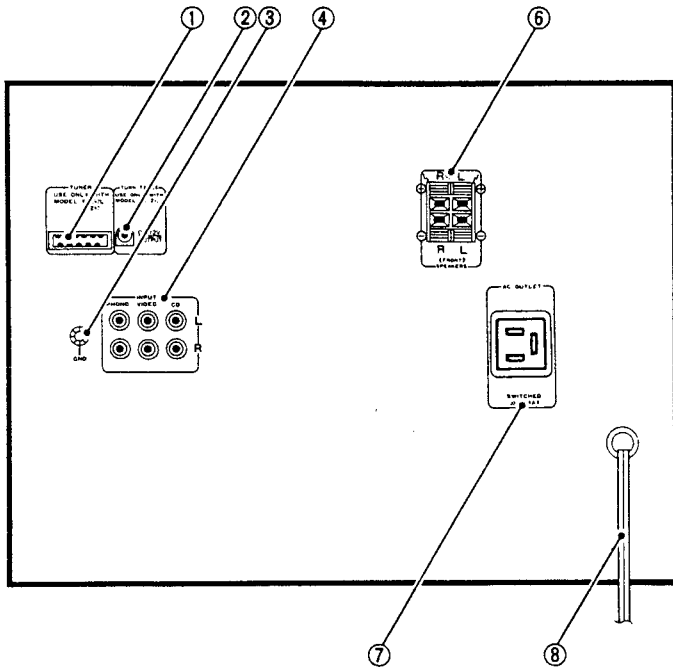

REAR PANEL FACILITIES

Cassette tape deck amplifier: DC-Z72

① TUNER jacks

Connect the F-Z92 (or F-Z92L) FM/AM tuner.

② TURNTABLE OUTPUT jack

This jack supplies power to the PL-Z82 or PL-Z92.

③ Ground terminal (GND)

Connect this to the ground terminal on the turntable (except for PL-Z92 and PL-Z82).

④ INPUT jacks

PHONO: Connect the audio output cord on the turntable to these jacks.

VIDEO: Connect to audio output jacks of LD player or VCR, etc.

CD: Connect to audio output jacks of CD player.

⑥ SPEAKERS terminals

L: Connect the left speaker system as seen from the listening position.

R: Connect the right speaker system as seen from the listening position.

NOTE:

Connect a speaker system having a nominal impedance ranging from 6 Ω to 16 Ω .

⑦ AC OUTLET (SWITCHED 100 W MAX)

Power supplied through these outlets is turned on and off by the cassette tape deck amplifier's POWER switch. Total electrical power consumption of connected equipment should not exceed 100 W.

NOTE:

Do not connect appliances with high power consumption such as heaters, irons, or television sets to the AC OUTLET in order to avoid overheating or fire risk.

This can cause the cassette tape deck amplifier to malfunction.

⑧ Power cord

Connect this to the AC wall socket.

FRONT PANEL FACILITIES

Cassette tape deck amplifier: DC-Z72

- Tapes can be played back on deck I; tapes can be played back and recorded on deck II.
- Sound can be recorded as adjusted by the graphic equalizer.

Amplifier/Graphic equalizer section

① POWER STANDBY/ON switch

When this switch is set to the on position, power is supplied to the cassette tape deck amplifier's main circuit. The POWER unit's switch is geared to selecting the transformer's secondary so that even in STANDBY position, the unit's circuitry will work as long as the power cord is connected to a power outlet. Disconnect the power cord from the power outlet when you do not plan to use the unit for a long period of time.

The unit is in STANDBY when the tuner section display indicates only the time.

② Headphone jack (PHONES)

For stereo headphone plug.

③ FUNCTION switches/indicators

[CD]

Press to listen to a CD player connected to the CD jacks.

[PHONO]

Press to play records on a turntable connected to the PHONO jacks.

[TUNER]

Press to listen to a radio broadcast.

[TAPE]

Press to listen to a cassette tape.

[VIDEO]

Press to listen to a stereo component connected to the VIDEO jacks.

④ VOLUME control

⑤ Graphic equalizer controls

Fine adjustments in sound quality are possible using the 5 controls on the graphic equalizer. These let you simultaneously adjust the tonal quality the left and right channels.

Cassette Tape Deck Section

⑥ Deck I cassette door

⑦ DOLBY* NR switch

Set this switch to the ON position to activate the DOLBY NR system.

- Tapes recorded using Dolby noise reduction should always be played back with the noise reduction system on. Sound quality will be adversely affected if they are played back with the system off, or if tapes recorded using a different noise reduction system are played back with the Dolby NR system on.
- It is recommended that tapes recorded using Dolby B NR be so marked on the label. This will help to prevent incorrect setting of the noise reduction switch during playback.

*
Dolby noise reduction manufactured under license from Dolby Laboratories Licensing Corporation.
"DOLBY" and the double-D symbol  are trademarks of Dolby Laboratories Licensing Corporation.

⑧ ASES switch

Use to automatically record a CD on cassette tape.

⑨ Operation indicators

ASES: Lights when the ASES (Auto Synchro Editing System) is operating.



RECORDING: Lights when recording. Flashes when copying a tape.

Slow flashing = Normal copy

Rapid flashing = High speed copy

Direction (◀ ▶): Show direction of tape travel.

⑩ REVERSE MODE switch

Switch position	During playback	During recording
REC RELAY  PLAY	Plays both tape sides. When one deck finishes playback, the other side begins playback of both tape sides (6 times maximum). If there is a tape in only one deck, then that deck continuously plays both sides of the tape (6 times maximum).	Records on one side (Deck II only).
REC PLAY  	Plays both sides continuously (6 times maximum).	Records on both sides (Deck II only).

⑪ Deck II cassette door

⑫ Deck I Operation switches

- ▶ PLAY (FWD)..... For playing back a tape in the forward mode.
- ◀ PLAY (REV)..... For playing back a tape in the reverse mode.
- STOP..... For stopping the tape.
- ▶▶ FAST Fast forward in forward mode, rewind in reverse mode.
- ◀◀ FAST Rewind in forward mode, fast forward in reverse mode.

⑬ Deck I EJECT switch

⑭ SYNCHRO COPY switches

Use for tape copying.

NORMAL: Copying from the Deck I tape to the Deck II tape at normal recording/playback speed.

HIGH: Copying at about twice normal tape speed. (Copies can be made in about half the NORMAL time.)

⑮ MUTE () switch (Deck II)

Use to create an unrecorded blank space between songs. The unrecorded space will be created for as long as this switch is kept depressed during recording.

⑯ REC () switch (Deck II)

Set to recording standby mode. Recording will then begin when you press the PLAY switch (◀ or ▶).

⑰ PAUSE () switch (Deck II)

Temporarily stops tape travel. Cancels pause mode when pressed again.

⑱ Deck II EJECT switch

⑲ Deck II Operation switches

- ▶ PLAY (FWD)..... For playing back a tape in the forward mode.
- ◀ PLAY (REV)..... For playing back a tape in the reverse mode.
- STOP..... For stopping the tape.
- ▶▶ FAST Fast forward in forward mode, rewind in reverse mode.
- ◀◀ FAST Rewind in forward mode, fast forward in reverse mode.

Remote control unit

① PHONO key

Sets function to PHONO.

② POWER key

③ TUNER STATION keys

• Before operation, memorize broadcast stations in the STATION CALL switches.

- + Stations change in order in the upward direction.
- Stations change in order in the downward direction.

④ Deck I operation keys

- ▶ Forward play
- ◀ Reverse play
- Stop

⑤ Timer operation keys

SLEEP: Sets the sleep timer. Each time you press this key, the setting changes as shown here. The current setting is shown on the tuner display. Power turns off when your set time has elapsed.

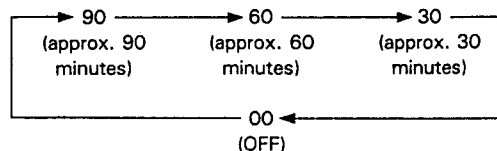

If you press the SLEEP key during SLEEP operation, the display will show the time remaining till power turns off.

SNOOZE: Turns off power if pressed after timer playback begins. Timer playback begins again approx. 5 minutes later.

⑥ VOLUME UP (+)/DOWN (-) keys

⑦ Deck II operation keys

- ▶ Forward play
- ◀ Reverse play
- ▶▶ Fast forward
- ◀◀ Fast reverse
- Stop
- || Pause
- REC (recording standby). Next, press the play key to begin recording.

⑧ CD operation keys

Make the connections so that the CD player can be operated by the remote control unit.

- ▶ Play
- DISC DISC selection
- Stop
- || Pause
- ◀◀, ▶▶ Track search

NOTE:

Note that the DISC selector key on the accessory remote control unit may not function, depending on the CD player used.

The amplifier section function automatically switches to the music source being operated when you press the CD playback (▶), cassette tape deck playback (◀, ▶), or tuner station controls.

To operate with the remote control unit, use the keys with the same function indicating symbols (for example ▶) as those shown on the components.

NOTE:

It is not possible to operate the CD player with the remote control unless the remote control cord is connected

Range of remote control

When the remote control unit is pointed at the remote sensor window on the tuner and any of its keys is pressed, the tuner and other components can be operated by remote control.

Distance: Within a range of approx. 7 meters from the remote sensor window on the tuner.

Angle: Within approx. 30 degrees from the center of the remote sensor window on the tuner.

Remote control will not be possible if there is an obstacle between the remote control unit itself and the remote sensor window on the tuner.