

# Service Manual

**CIRCUIT DESCRIPTIONS  
REPAIR & ADJUSTMENTS**

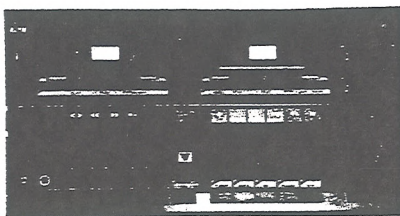

**ORDER NO.  
ARP1055 - 0**

## STEREO DOUBLE CASSETTE TAPE DECK AMPLIFIER **DC-X55Z(BK)** **DC-X55Z**

MODEL DC-X55Z(BK) AND DC-X55Z COMES IN SEVEN VERSIONS DISTINGUISHED AS FOLLOWS:

Type	Applicable model		Power requirement	Destination
	DC-X55Z(BK)	DC-X55Z		
HB	○	○	AC220V, 240V*(Switchable)	United Kingdom
HEZ	○	—	AC220V, 240V*(Switchable)	West Germany
KC	○	—	AC120V only	Canada
YP	○	—	AC240V only	Australia
HE	○	○	AC220V, 240V*(Switchable)	European continent
KU	○	—	AC120V only	U.S.A
S	○	—	AC110V, 120V, 220V, 240V (Switchable)	General market

- This service manual is applicable to the HB type. \* Change the primary wiring of the power transformer.
- As to the other types, please refer to the additional service manual.
- Ce manuel d'instruction se fefere au mode de réglage en français.
- Este manual de servicio trata del método ajuste escrito en español.

### CONTENTS

1. SAFETY INFORMATIONS .....	2	9. SCHEMATIC DIAGRAM .....	27
2. SPECIFICATIONS .....	2	10. CIRCUIT DESCRIPTIONS .....	31
3. FRONT PANEL FACILITIES .....	3	11. MECHANISM OUTLINE .....	42
4. PARTS LOCATION .....	5	12. ADJUSTMENTS .....	48
5. EXPLODED VIEWS .....	7	RÉGLAGE .....	54
6. PACKING .....	10	AJUSTE .....	60
7. ELECTRICAL PARTS LIST .....	19	13. DISASSEMBLY .....	66
8. P.C.BOARDS CONNECTION DIAGRAM .....	23		

# 1. SAFETY INFORMATION

## 1. SAFETY PRECAUTIONS

The following check should be performed for the continued protection of the customer and service technician.

### LEAKAGE CURRENT CHECK

Measure leakage current to a known earth ground (water pipe, conduit, etc.) by connecting a leakage current tester such as Simpson Model 229-2 or equivalent between the earth ground and all exposed metal parts of the appliance (input/output terminals, screwheads, metal overlays, control shaft, etc.). Plug the AC line cord of the appliance directly into a 120V AC 60Hz outlet and turn the AC power switch on. Any current measured must not exceed 0.5mA.

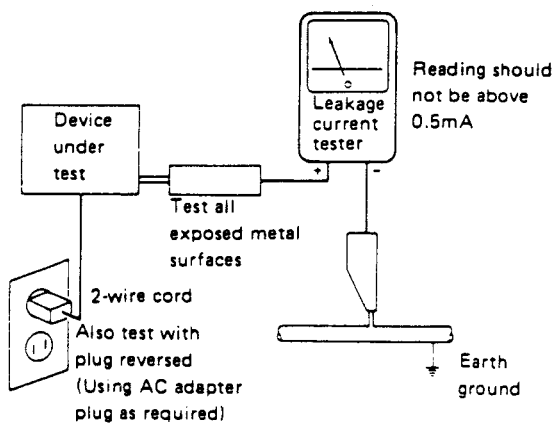

AC Leakage Test

## 2. SPECIFICATIONS

### AMPLIFIER SECTION

Continuous Average Power Output is 40 Watts\* per channel, min., at 8 ohms from 40 Hertz to 20,000 Hertz, with no more than 0.3% total harmonic distortion.

\*Measured pursuant to the Federal Trade Commission's Trade Regulation rules on Power Output Claims for Amplifiers.

Continuous Power Output	
40 to 20,000Hz	40 W + 40 W (T.H.D. 0.3% 8 ohms)
1 kHz (DIN)	50 W + 50 W (T.H.D. 1% 8 ohms)
1 kHz (DIN music power)	70 W + 70 W (T.H.D. 1% 8 ohms)
PMPO	140 W + 140 W
Hum and Noise (IHF, short-circuited, A network)	
PHONO	72 dB
Hum and Noise (DIN continuous Power/50 mV)	
PHONO	68 dB/60 dB
Total Harmonic Distortion (40 Hz to 20,000 Hz, 8 ohms)	
20 Watts per channel power output	No more than 0.2%

### Tape Deck Section

Systems	4 track, 2-channel stereo
Heads	"Hard Permalloy" recording/playback head x 1 "Hard Permalloy" playback head x 1 "Ferrite" erasing head x 1
Motor	DC servo 2 speed motor x 2
Wow and Flutter	No more than 0.09% (WRMS)
Fast Winding Time	Approximately 100 seconds (C-60 tape)

ANY MEASUREMENTS NOT WITHIN THE LIMITS OUTLINED ABOVE ARE INDICATIVE OF A POTENTIAL SHOCK HAZARD AND MUST BE CORRECTED BEFORE RETURNING THE APPLIANCE TO THE CUSTOMER.

## 2. PRODUCT SAFETY NOTICE

Many electrical and mechanical parts in the appliance have special safety related characteristics. These are often not evident from visual inspection nor the protection afforded by them necessarily can be obtained by using replacement components rated for voltage, wattage, etc. Replacement parts which have these special safety characteristics are identified in this Service Manual.

Electrical components having such features are identified by marking with a  $\Delta$  on the schematics and on the parts list in this Service Manual.

The use of a substitute replacement component which does not have the same safety characteristics as the PIONEER recommended replacement one, shown in the parts list in this Service Manual, may create shock, fire, or other hazards.

Product Safety is continuously under review and new instructions are issued from time to time. For the latest information, always consult the current PIONEER Service Manual. A subscription to, or additional copies of, PIONEER Service Manual may be obtained at a nominal charge from PIONEER.

### Frequency Response

-20 dB recording:	
Normal tape	35 Hz to 14,000 Hz $\pm$ 6 dB
CrO <sub>2</sub>	35 Hz to 15,000 Hz $\pm$ 6 dB
Metal tape	35 Hz to 16,000 Hz $\pm$ 6 dB

### Signal-to-Noise Ratio

Dolby NR OFF	56 dB
--------------	-------

### Noise Reduction Effect

Dolby B type NR ON	More than 10 dB (at 5 kHz)
--------------------	----------------------------

### Furnished Parts

Operating Instructions	1
Turntable legs parts	2

### Miscellaneous

#### Power requirements

U.S., Canadian models	AC 120 V, 60 Hz
European model	AC 220 V, 50/60Hz
U.K. and Australian models	AC 240 V, 50/60 Hz
Other destination models	AC 110/120/220/240 V (switchable) 50/60 Hz

#### Power Consumption

U.S., Canadian models	230 W (CSA 260 VA)
European model	380 W
U.K. and Australian models	380 W
Other destination models	230 W

#### Dimensions

	360(W) x 190(H) x 283 (D) mm
--	------------------------------

	14-3/16(W) x 7-7/16(H) x 11-1/8(D) in
--	---------------------------------------

#### Weight (without package)

	7.4 kg (16 lb 5 oz)
--	---------------------

### 3. FRONT PANEL FACILITIES

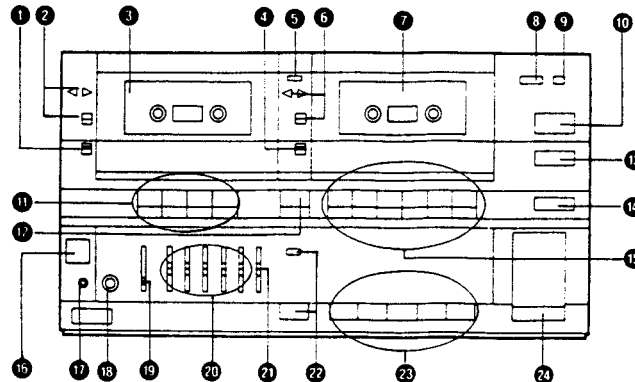

**[CASSETTE TAPE DECK]**

- This unit is provided with an automatic tape selector function.
- This unit is a forward mode priority auto-reverse deck. Both recording and playback always start in the forward direction. If you press the STOP/EJECT (■/▲) switch during reverse playback, the head for forward playback will be reselected automatically.

**1 REVERSE MODE switch**

Sets the reverse mode for the playback-only deck.

Switch positions:	Play
	Continuous play
	Reverse play

Continuous playback is automatically stopped after 8 round trips. Note that it will be counted as one reversal if the tape direction is changed using the direction switch. (One round trip will be counted if the switch is pressed twice.)

**2 Direction switch/indicator (DIRECTION)**

Depress to set the playback direction of the playback-only deck. Direction change can only be performed during playback.

- ▷ ... Lights when forward mode is selected.
- ◁ ... Lights when reverse mode is selected.

**3 Cassette compartment (Playback only)**

**4 REVERSE MODE switch**

Sets the reverse mode for the record/play deck.

Switch positions	Play	Record
	Continuous play	Double-side recording
	Reverse play	Single-side recording

Continuous playback is automatically stopped after 8 round trips. Note that it will be counted as one reversal if the tape direction is changed using the direction switch. (One round trip will be counted if the switch is pressed twice.)

**5 Recording indicator (REC)**

- ... Lights during recording. Flashes during tape copying. (DC-X55Z and DC-555Z only)

**6 Direction switch/indicator (DIRECTION)**

Depress to set the recording and playback direction of the record/play deck. Direction change can be performed during recording, playback or pause.

- ▷ ... Lights when forward mode is selected. Flashes if tape travel is stopped during reverse recording.
- ◁ ... Lights when reverse mode is selected.

**7 Cassette compartment (Recording and playback)**

**8 TAPE COUNTER (Record/play deck.)**

3-digit display measures tape travel on record/play deck.

**9 TAPE COUNTER RESET button**

## ⑩ COPY SPEED switch

Press to set the copy mode.

- NORMAL ... Permits you to listen to playback normally during dubbing (normal speed copying)
- HIGH ... High speed dubbing (double-speed, half-time copying)

## ⑪ Playback-only switches

- ◀▶ (PLAY) ... Forward or reverse mode playback.
- ◀ (FAST) ... Rewind in forward mode, fast forward in reverse mode.
- ▶ (FAST) ... Fast forward in forward mode, rewind in reverse mode.
- /▲ (STOP/EJECT) ... Stops tape travel. Ejects cassette if pressed when tape is stopped.

## ⑫ Synchronized copy switch (SYNCHRO COPY)

Press to start copying from Deck I to Deck II. Set the copying speed (NORMAL or HIGH) using the COPY SPEED switch.

- Press this switch only after you have set the COPY SPEED switch as desired. If this switch is pressed first, the speed cannot afterwards be changed, even if the COPY SPEED switch position is later changed.

## ⑬ Dolby NR switch

Press to activate noise reduction system. Use to play back tapes recorded using Dolby B NR noise reduction.

- Tapes recorded using Dolby B NR noise reduction should always be played back with the noise reduction system on. Sound quality will be adversely affected if they are played back with the system off, or if tapes recorded using a different noise reduction system are played back with the Dolby B NR system on.
- It is recommended that tapes recorded using Dolby B NR be so marked on the label. This will help to prevent incorrect setting of the noise reduction switch during playback.

~~~~~  
Noise reduction manufactured under license from Dolby Laboratories Licensing Corporation.

"Dolby" and the double-D symbol are trademarks of Dolby Laboratories Licensing Corporation.

~~~~~

## ⑭ Recording mute switch (REC MUTE)

Use to create blank intervals on a tape during recording. Works only while held depressed.

## ⑮ Record/Playback switches

- (REC) ..... Record
- ◀▶ (PLAY) .. Playback in forward or reverse mode.
- ◀ (FAST) ..... Rewind in forward mode, fast forward in reverse mode.
- ▶ (FAST) ..... Fast forward in forward mode, rewind in reverse mode.
- /▲ (STOP/EJECT) .. Stops tape travel. Ejects cassette if pressed when tape is stopped.
- (PAUSE) .... Temporarily stops tape travel. Cancels pause mode when pressed again.

## [AMPLIFIER/GRAPHIC EQUALIZER]

### ⑯ Power switch (POWER)

### ⑰ Headphone jack (PHONES)

For miniature stereo phone plug.

### ⑱ Microphone jack (MIC)

For standard phone plug.

## ⑲ Mic Mixing Controls (MIC MIXING)

Adjusts balance between mic volume and volume of other input sources.

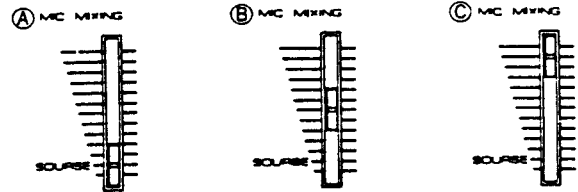

Source input emphasized

To listen to the sound from a microphone mixed with that of a radio broadcast or tape playback:

Mic input emphasized

### NOTE:

- Set the control to the SOURCE position as shown in Fig. A when not using a microphone.
- Source volume is cut by about 1/100 when control is set to the MIC position.

## ⑳ Graphic equalizer controls (GRAPHIC EQUALIZER)

Fine adjustments in sound quality are possible using the 5 controls on the graphic equalizer.

### ㉑ BALANCE control

### ㉒ SURROUND/STEREO WIDE switch/indicator

By using this function, the sounds from stereo sources will be given new breadth, reproducing the effect of concert hall presence.

### NOTE:

*Stereo Wide sound has no effect on monaural sources (AM broadcasts, etc.).*

## ㉓ Function switches (FUNCTION)

Press the button corresponding to the desired program source.

- TUNER ..... Press to listen to radio.
- VIDEO ..... Press to listen to component (Hi-Fi VCR, laser disc player, etc.) connected to the auxiliary input jacks.
- CD ..... Press to listen to CD player.
- PHONO ..... Press to listen to turntable.
- TAPE ..... Press to listen to tape playback.

## ㉔ Volume Control (VOLUME)

## 4. PARTS LOCATION

**NOTES:**

- The  $\Delta$  mark found on some component parts indicates the importance of the safety factor of the part. Therefore, when replacing, be sure to use parts of identical designation.
- For your Parts Stock Control, the fast moving items are indicated with the marks **★★** and **★**.  
**★★ GENERALLY MOVES FASTER THAN ★**  
 This classification shall be adjusted by each distributor because it depends on model number, temperature, humidity, etc.
- Parts marked by "⊙" are not always kept in stock. Their delivery time may be longer than usual or they may be unavailable.

### Front Panel View

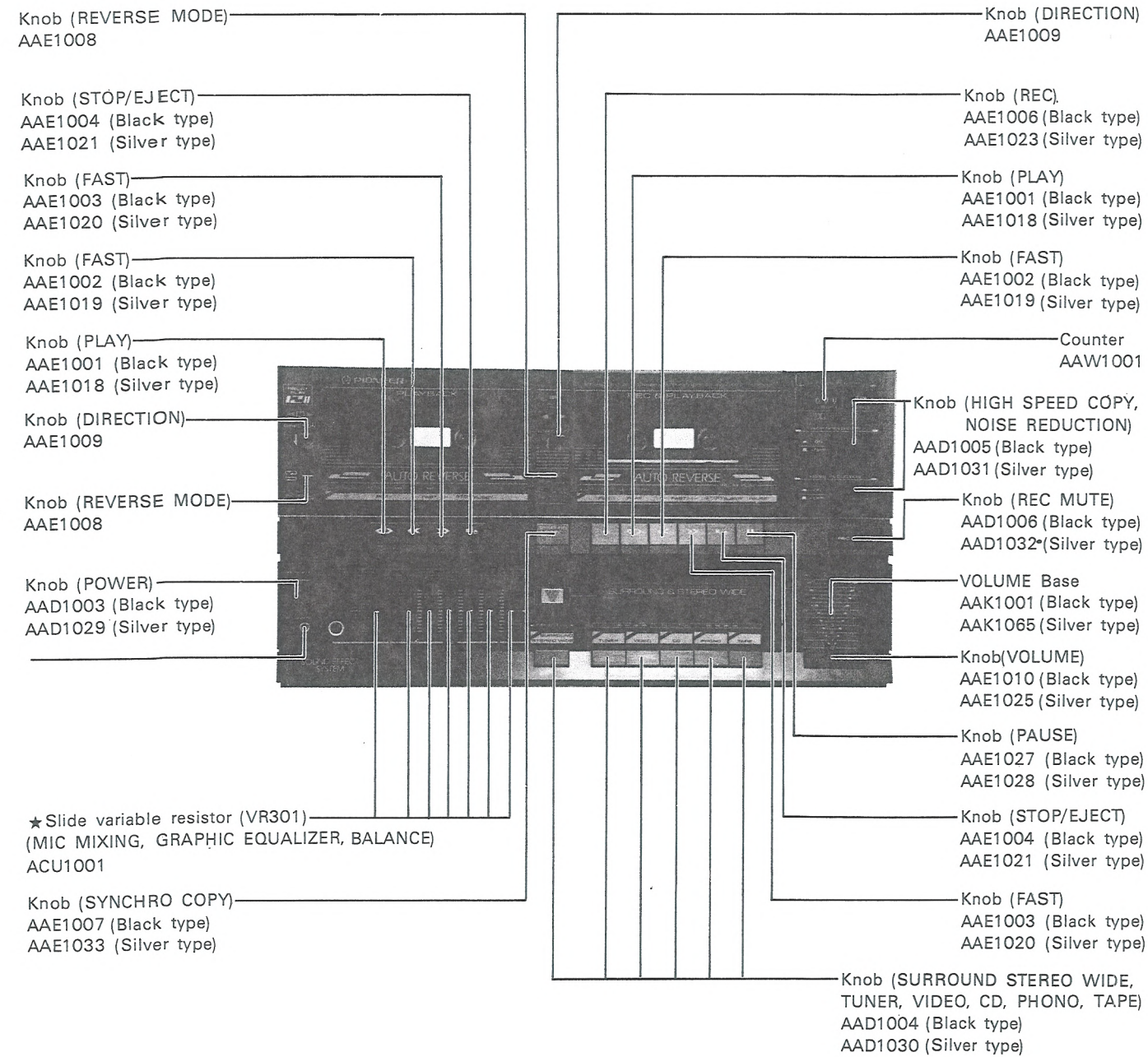

### Top View with Bonnet Case Removed

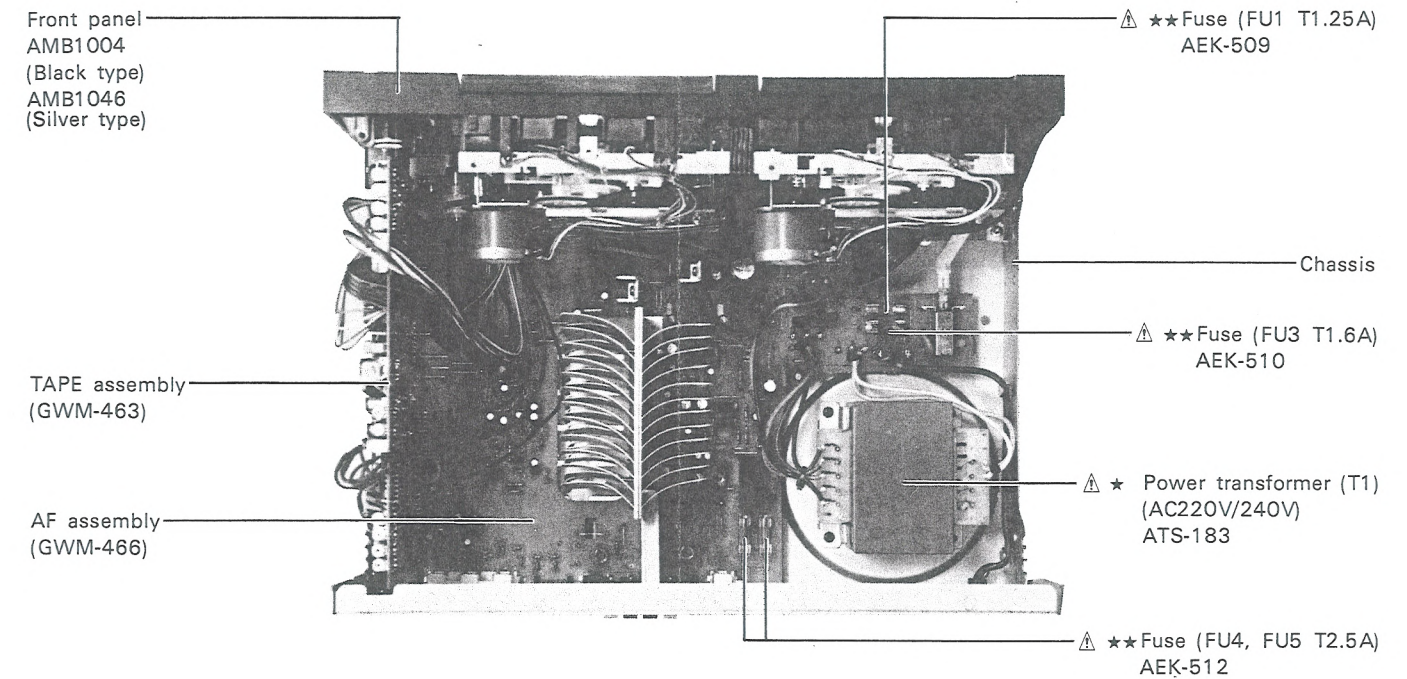

### Rear Panel View

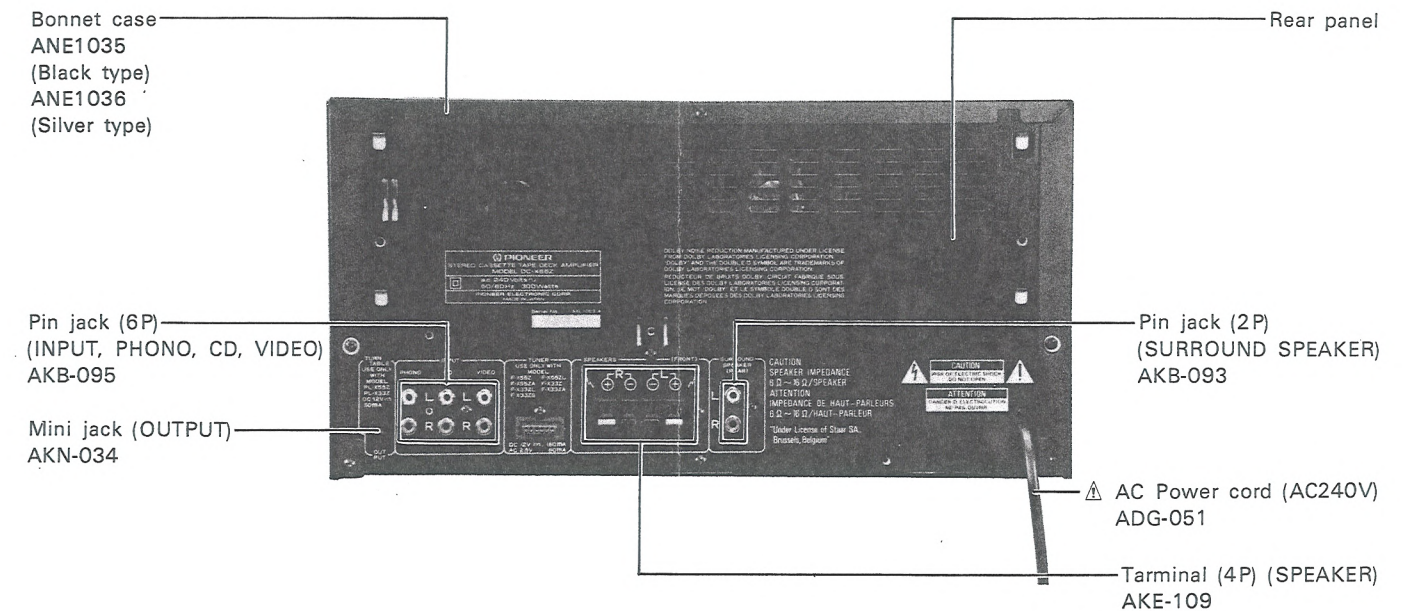

# 5. EXPLODED VIEWS

## 5.1 Exterior

### NOTES:

- Parts without part number cannot be supplied.
- The  $\downarrow$  mark found on some component parts indicates the importance of the safety factor of the part. Therefore, when replacing, be sure to use parts of identical designation.
- For your Parts Stock Control, the fast moving items are indicated with the marks **★★** and **★**.  
**★★ GENERALLY MOVES FASTER THAN ★**  
 This classification shall be adjusted by each distributor because it depends on model number, temperature, humidity, etc.
- Parts marked by "⊙" are not always kept in stock. Their delivery time may be longer than usual or they may be unavailable.

A

—

B

—

C

—

D

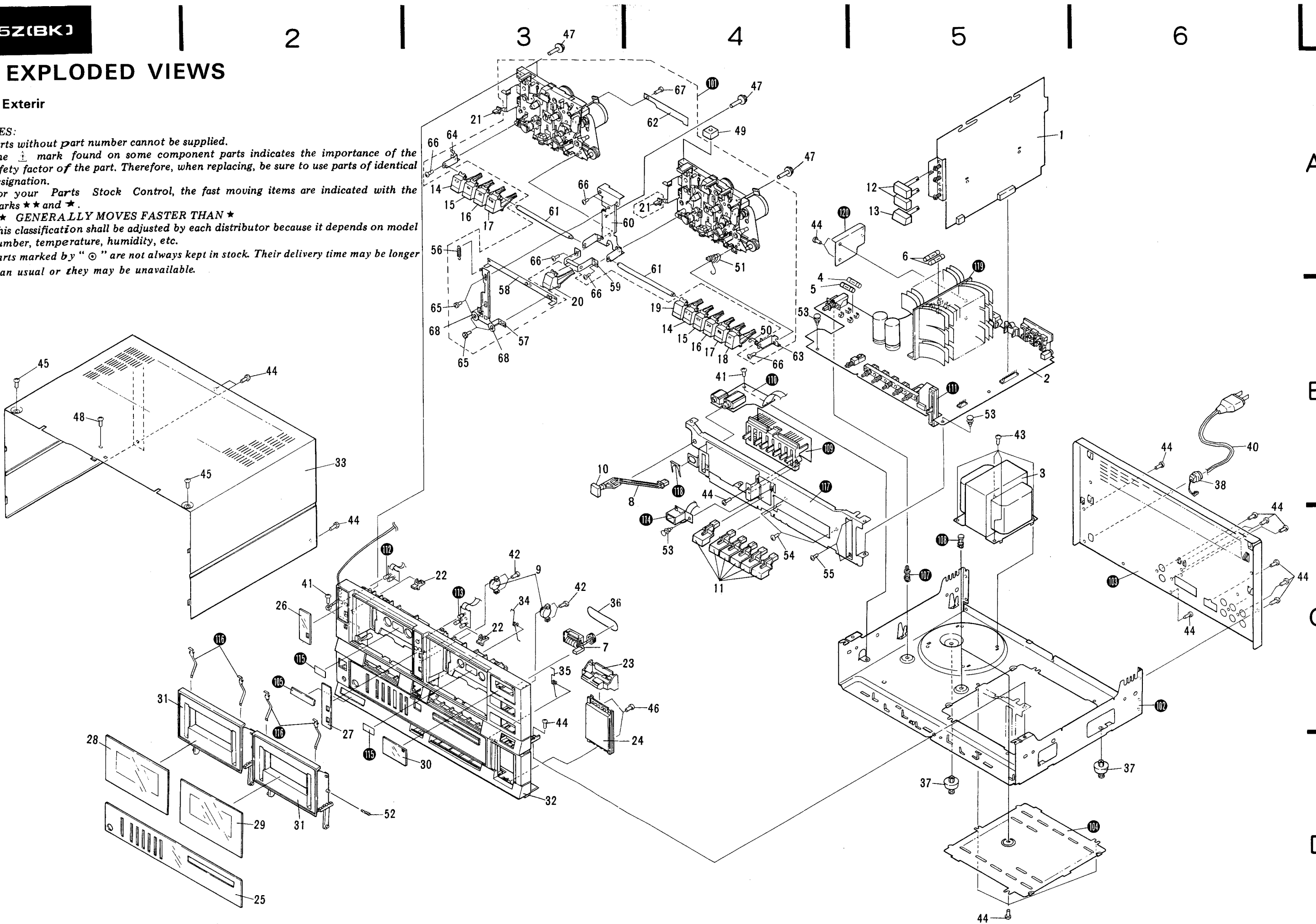

A

B

C

D

1

2

3

4

5

6

5.2 Mechanism 1

A

B

C

D

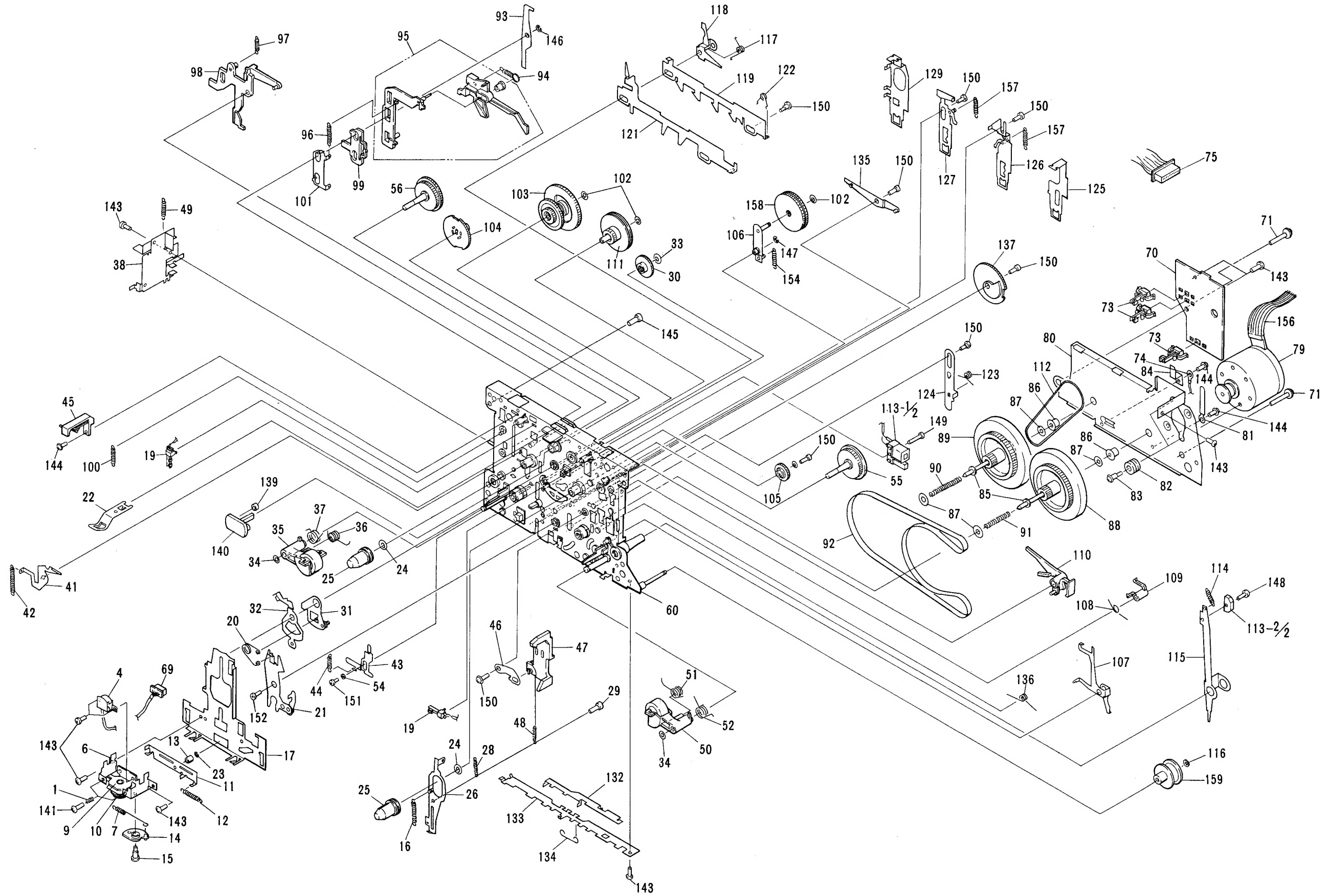

1

2

3

4

5

6

**NOTES:**

- *Parts without part number cannot be supplied.*
- *The  $\Delta$  mark found on some component parts indicates the importance of the safety factor of the part. Therefore, when replacing, be sure to use parts of identical designation.*
- *For your Parts Stock Control, the fast moving items are indicated with the marks **\*\*** and **\***.*  
**\*\* GENERALLY MOVES FASTER THAN \***  
*This classification shall be adjusted by each distributor because it depends on model number, temperature, humidity, etc.*
- *Parts marked by "  $\odot$  " are not always kept in stock. Their delivery time may be longer than usual or they may be unavailable.*

**Parts List of Mechanism 1**

Mark	No.	Part No.	Description	Mark	No.	Part No.	Description
	1	AZN1055	Pressure spring		41	AZN1087	MO plate
	2	.....	.....		42	AZN1088	Coiled spring
	3	.....	.....		43	ANZ1089	Reverse sub-plate
<b>**</b>	4	AZP1007	PLAY head		44	AZN1090	Reverse spring
	5	.....	.....	<b>**</b>	45	AZS1015	Leaf switch (ARR/C-O2 SW)
	6	AZN1058	Metal assembly I		46	AZN1091	Latch slide plate
	7	AZN1059	Head GR spring		47	AZN1092	Latch lever
	8	.....	.....		48	AZN1093	Latch-return spring
	9	AZN1061	Head holder assembly I		49	AZN1094	DIR lever spring
	10	AZN1062	Head gear (A)		50	AZN1095	Pinch arm assembly (R)
	11	AZN1063	Slide plate assembly		51	AZN1096	Twist spring
	12	AZN1064	Slide plate spring		52	AZN1097	Pinch roller spring (R)
	13	AZN1065	Collar		53	.....	.....
	14	AZN1066	Head gear (B)		54	AZN1099	Collar
	15	AZB1032	Step screw		55	AZN1100	Reel base assembly (R)
	16	AZN1067	Return spring		56	AZN1101	Reel base assembly (F)
	17	AZN1068	Head base		57	.....	.....
	18	.....	.....		58	.....	.....
<b>**</b>	19	AZS1013	Leaf switch (DIR, MUT SW)		59	.....	.....
	20	AZN1069	Reverse spring		60	AZN1105	Mechanism chassis
	21	AZN1070	Pinch lever assembly		61	.....	.....
	22	AZN1071	Half set arm		62	.....	.....
	23	AZN1072	P washer		63	.....	.....
	24	AZB1034	Washer		64	.....	.....
	25	AZN1073	Reel claw		65	.....	.....
	26	AZN1074	Sub-plate assembly		66	.....	.....
	27	.....	.....		67	.....	.....
	28	AZN1075	Head-return spring		68	.....	.....
	29	AZB1033	Step screw		69	AZK1025	4P connector
	30	AZN1076	Idler gear		70	AEN1110	P.C. board (I)
	31	AZN1077	Idler assembly		71	AZB1036	Flange screw M2.6x28
	32	AZN1078	Reverse plate A		72	.....	.....
	33	AZN1079	P washer 1.3x3x0.25	<b>**</b>	73	AZS1016	Leaf switch
	34	AZN1080	P washer		74	AZD1003	Ground wire
	35	AZN1081	Pinch arm assembly (L)		75	AZK1026	11P connector
	36	AZN1082	Twist spring		76	.....	.....
	37	AZN1083	Pinch roller return spring		77	.....	.....
	38	AZN1084	Mounting plate assembly		78	.....	.....
	39	.....	.....		79	AZX1005	Motor assembly
	40	.....	.....	<b>**</b>	80	AZN1114	F/W base plate



Mark	No.	Part No.	Description	Mark	No.	Part No.	Description
	81	AZN1115	Wire holder assembly	121	AZN1156		Plate (B)
	82	AZN1116	Rubber washer	122	AZN1157		Plate
	83	AZB1037	Motor mounting screw	123	AZN1158		Stop spring pause spring
	84	AZN1117	Synchro holder	124	AZN1159		Detector sub-plate
	85	AZN1118	P washer	125	AZN1160		Stop plate
	86	AZN1119	Metal	126	AZN1161		FF plate assembly
	87	AZN1120	P washer 2.6x8x0.13	127	AZN1162		REW plate assembly
	88	AZN1113	Flywheel assembly (R)	128	.....		.....
	89	AZN1121	Flywheel assembly (L)	129	AZN1164		PLAY plate
	90	AZN1122	Pressure spring (black)	130	.....		.....
	91	AZN1123	Pressure spring (white)	131	.....		.....
	92	AZN1124	Flat belt	132	AZN1167		Plate (C)
	93	AZN1125	Rerease lever	133	AZN1168		Knob holder plate
	94	AZN1126	Spring	134	AZN1169		Lead clamber
	95	AZN1127	Detector lever assembly	135	AZN1170		Assist arm assembly
	96	AZN1128	Spring	136	AZN1171		Trigger return spring
	97	AZN1129	Spring	137	AZN1172		Assist gear
	98	AZN1130	DIR lever	138	.....		.....
	99	AZN1131	Mode lever	139	AZN1174		Collar
	100	AZN1132	Coiled spring	140	AZN1175		Reverse cam assembly
	101	AZN1133	Mode plate	141	AZB1038		Pan-screw
	102	AZN1134	P washer 1.6x4x0.25	142	.....		.....
	103	AZN1135	Tension pulley assembly	143	AZB1040		Screw
	104	AZN1136	Reverse gear	144	AZB1041		Flange screw
	105	AZN1137	FWD gear	145	AZB1042		FT screw
	106	AZN1138	FF idler plate assembly	146	AZN1176		CS ring
	107	AZN1142	Anti-detect plate	147	AZN1177		E-ring
	108	AZN1143	Twist spring	148	AZB1043		Screw
	109	AZN1144	Clutch stopper	149	AZB1044		Screw
	110	AZN1145	Anti-detect lever	150	AZB1045		Bushing
	111	AZN1146	Drive pulley	151	AZB1046		Bind screw
	112	AZN1147	Square belt	152	AZB1047		Bushing
	113	AZN1148	Magnet	153	.....		.....
	114	AZN1149	Magnet spring	154	AZN1179		FF idler plate spring
	115	AZN1150	Magnet arm	155	.....		.....
	116	AZN1151	Washer	156	AZD1004		Jumper wire
	117	AZN1152	SW drive spring	157	AZN1139		FF.REW gear spring
	118	AZN1153	SW push plate	158	AZN1140		FF idler assembly
	119	AZN1154	PB plate (A)	159	AZN1141		Idler assembly
	120	.....	.....				

5.3 Mechanism 2

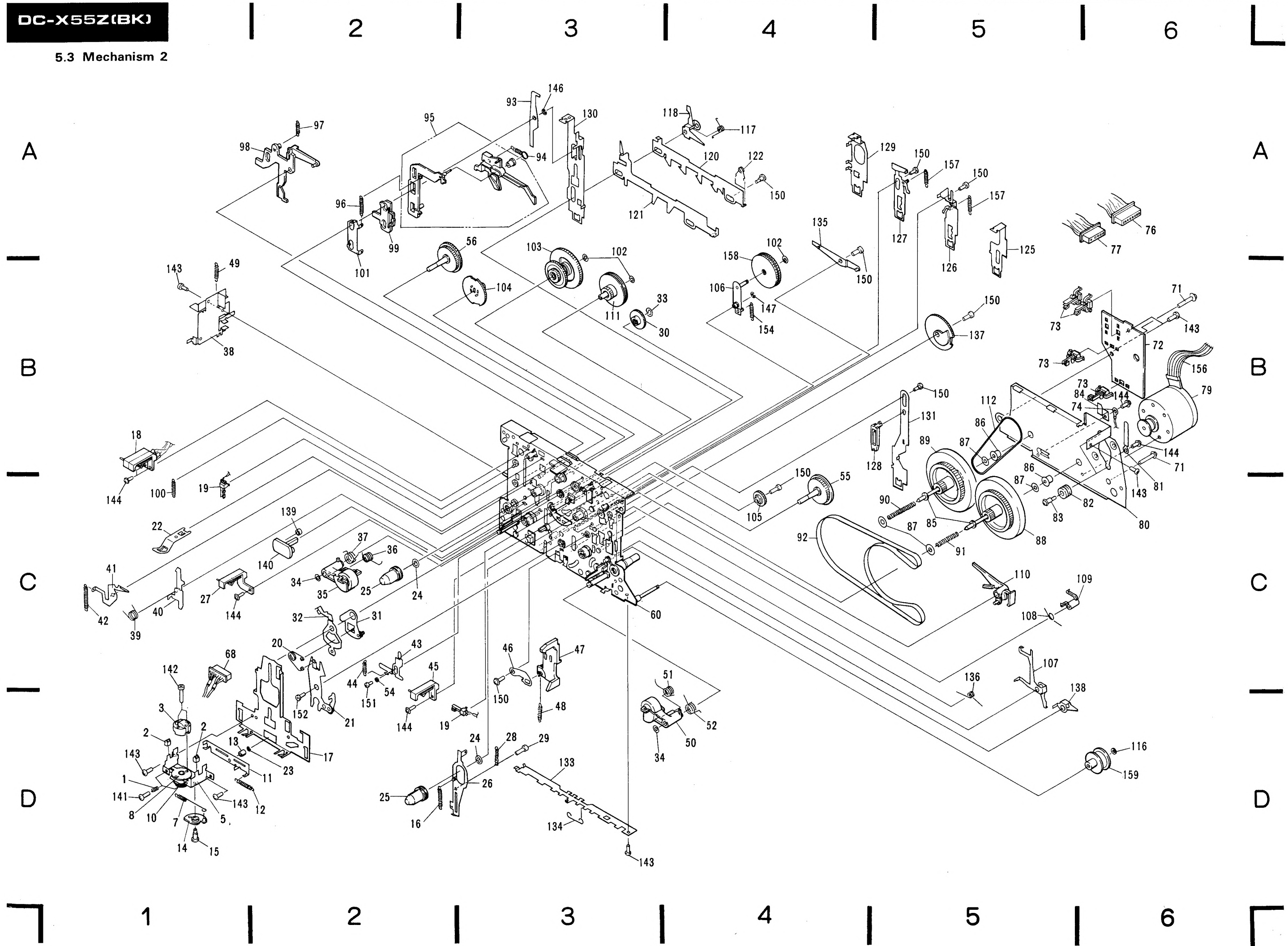

**NOTES:**

- Parts without part number cannot be supplied.
- The  $\Delta$  mark found on some component parts indicates the importance of the safety factor of the part. Therefore, when replacing, be sure to use parts of identical designation.
- For your Parts Stock Control, the fast moving items are indicated with the marks **\*\*** and **\***.  
**\*\* GENERALLY MOVES FASTER THAN \***  
 This classification shall be adjusted by each distributor because it depends on model number, temperature, humidity, etc.
- Parts marked by "⊙" are not always kept in stock. Their delivery time may be longer than usual or they may be unavailable.

**Parts List of Mechanism 2**

Mark	No.	Part No.	Description	Mark	No.	Part No.	Description
	1	AZN1055	Pressure spring		41	AZN1087	MO plate
	2	AZN1056	Tape guide		42	AZN1088	Coiled spring
**	3	AZP1006	Head assembly (REC/PB and ERACE)		43	ANZ1089	Reverse sub-plate
	4	.....	.....		44	AZN1090	Reverse spring
	5	AZN1057	Metal assembly II	**	45	AZS1015	Leaf switch (ARR/CrO <sub>2</sub> SW)
	6	.....	.....		46	AZN1091	Latch slide plate
	7	AZN1059	Head GR spring		47	AZN1092	Latch lever
	8	AZN1060	Head holder assembly II		48	AZN1093	Latch-return spring
	9	.....	.....		49	AZN1094	DIR lever spring
	10	AZN1062	Head gear (A)		50	AZN1095	Pinch arm assembly (R)
	11	AZN1063	Slide plate assembly		51	AZN1096	Twist spring
	12	AZN1064	Slide plate spring		52	AZN1097	Pinch roller spring (R)
	13	AZN1065	Collar		53	.....	.....
	14	AZN1066	Head gear (B)		54	AZN1099	Collar
	15	AZB1032	Step screw		55	AZN1100	Reel base assembly (R)
	16	AZN1067	Return spring		56	AZN1101	Reel base assembly (F)
	17	AZN1068	Head base		57	.....	.....
**	18	AZS1012	Leaf switch (ARF SW)		58	.....	.....
**	19	AZS1013	Leaf switch (DIR, MUT SW)		59	.....	.....
	20	AZN1069	Reverse spring		60	AZN1105	Mechanism chassis
	21	AZN1070	Pinch lever assembly		61	.....	.....
	22	AZN1071	Half set arm		62	.....	.....
	23	AZN1072	P washer		63	.....	.....
	24	AZB1034	Washer		64	.....	.....
	25	AZN1073	Reel claw		65	.....	.....
	26	AZN1074	Sub-plate assembly		66	.....	.....
**	27	AZS1014	Leaf switch (Metal sw)		67	.....	.....
	28	AZN1075	Head-return spring		68	AZK1024	8P connector
	29	AZB1033	Step screw		69	.....	.....
	30	AZN1076	Idler gear		70	.....	.....
	31	AZN1077	Idler assembly		71	AZB1036	Flange screw M2.6x28
	32	AZN1078	Reverse plate A		72	AZN1111	P.C.board (II)
	33	AZN1079	P washer 1.3x3x0.25	**	73	AZS1016	Leaf switch
	34	AZN1080	P washer		74	AZD1003	Ground wire
	35	AZN1081	Pinch arm assembly (L)		75	.....	.....
	36	AZN1082	Twist spring		76	AZK1027	8P connector
	37	AZN1083	Pinch roller return spring		77	AZK1028	5P connector
	38	AZN1084	Mounting plate assembly		78	.....	.....
	39	AZN1085	REC prevent spring	**	79	AZX1005	Motor assembly
	40	AZN1086	REC prevent plate		80	AZN1114	F/W base plate

Mark	No.	Part No.	Description	Mark	No.	Part No.	Description
	81	AZN1115	Wire holder assembly		121	AZN1156	Plate (B)
	82	AZN1116	Rubber washer		122	AZN1157	Plate spring
	83	AZB1037	Motor mounting screw		123	.....	.....
	84	AZN1117	Synchro holder		124	.....	.....
	85	AZN1118	P washer		125	AZN1160	Stop plate
	86	AZN1119	Metal		126	AZN1161	FF plate assembly
	87	AZN1120	P washer 2.6x8x0.13		127	AZN1162	REW plate assembly
	88	AZN1113	Flywheel assembly (R)		128	AZN1163	PAUSE arm
	89	AZN1121	Flywheel assembly (L)		129	AZN1164	PLAY plate
	90	AZN1122	Pressure spring (black)		130	AZN1165	REC plate
	91	AZN1123	Pressure spring (white)		131	AZN1166	PAUSE plate
	92	AZN1124	Flat belt		132	.....	.....
	93	AZN1125	Rerease lever		133	AZN1168	Knob holder plate
	94	AZN1126	Spring		134	AZN1169	Lead clamper
	95	AZN1127	Detector lever assembly		135	AZN1170	Assist arm assembly
	96	AZN1128	Spring		136	AZN1171	Trigger return spring
	97	AZN1129	Spring		137	AZN1172	Assist gear
	98	AZN1130	DIR lever		138	AZN1173	PAUSE arm
	99	AZN1131	Mode lever		139	AZN1174	Collar
	100	AZN1132	Coiled spring		140	AZN1175	Reverse cam assembly
	101	AZN1133	Mode plate		141	AZB1038	Pan-screw
	102	AZN1134	P washer 1.6x4x0.25		142	AZB1039	Screw
	103	AZN1135	Tension pulley assembly		143	AZB1040	Screw
	104	AZN1136	Reverse gear		144	AZB1041	Flange screw
	105	AZN1137	FWD gear		145	.....	.....
	106	AZN1138	FF idler plate assembly		146	AZN1176	CS ring
	107	AZN1142	Anti-detect plate		147	AZN1177	E-ring
	108	AZN1143	Twist spring		148	.....	.....
	109	AZN1144	Clutch stopper		149	.....	.....
	110	AZN1145	Anti-detect lever		150	AZB1045	Bushing
	111	AZN1146	Drive pulley		151	AZB1046	Bind screw
	112	AZN1147	Square belt		152	AZB1047	Bushing
	113	.....	.....		153	.....	.....
	114	.....	.....		154	AZN1179	FF idler plate spring
	115	.....	.....		155	.....	.....
	116	AZN1151	Washer		156	AZD1004	Jumper wire
	117	AZN1152	SW drive spring		157	AZN1139	FF.REW gear spring
	118	AZN1153	SW push plate		158	AZN1140	FF idler assembly
	119	.....	.....		159	AZN1141	Idler assembly
	120	AZN1155	REC/PB plate (A)				

## Parts List of Exterir

Mark	No.	Part No.	Description	Mark	No.	Part No.	Description
	1	GWM-463	TAPE assembly		24	AAK1001	VOLUME base
	2	GWM-466	AF assembly			(Black type)	
△ *	3	ATS-183	Power transformer (T1) (AC 220V/240V)			AAK1065	(Silver type)
	4	AEK-509	Fuse (FU1 T1.25A)		25	AAK1002	AMP panel
	5	AEK-510	Fuse (FU3 T1.6A)		26	AAK1003	Deck panel (A)
	6	AEK-512	Fuse (FU4, FU5 T2.5A)			(Black type)	
	7	AAW1001	Counter			AAK1066	(Silver type)
	8	AMR1003	Power joint		27	AAK1004	Deck panel (B)
	9	AMR1006	Damper assembly		28	AAK1005	Door panel (L)
	10	AAD1003	Knob (POWER)		29	AAK1006	Door panel (R)
		(Black type)			30	AAK1008	Counter panel
		AA1029				(Black type)	
		(Silver type)				AAK1067	(Silver type)
	11	AA1004	Knob (SURROUND, STEREO WIE, TUNER, CD, PHONO, TAPE)		31	AAN1001	Door
		(Black type)			32	AMB1004	Front panel
		AA1030				(Black type)	
		(Silver type)				AMB1046	(Silver type)
	12	AA1005	Knob (HIGH SPEED COPY, ON/OFF)		33	ANE1035	Bonnet case
		(Black type)				(Black type)	
		AA1031				ANE1036	(Silver type)
		(Silver type)					
	13	AA1006	Knob (REC MUTE)		34	ABH1001	Coil spring (L)
		(Black type)					
		AA1032			35	ABH1002	Coil spring (R)
		(Silver type)			36	AEB-197	Counter belt
	14	AAE1001	Knob (PLAY)		37	AEC-847	Leg assembly
		(Black type)		△	38	AEC-882	AC Cord stopper
		AAE1018			39	ABA1003	Screw
		(Silver type)					
	15	AAE1002	Knob (FAST)	±	40	ADG-051	AC Power cord (AC 240V)
		(Black type)			41	BBT30P080FMC	Screw
		AAE1019			42	BBZ20P100FMC	Screw
		(Silver type)			43	BBZ30P060FZK	Screw
	16	AAE1003	Knob (FAST)		44	BBZ30P080FZK	Screw
		(Black type)					
		AAE1020			45	VPZ30P080FZK	Screw
		(Silver type)				(Black type)	
	17	AAE1004	Knob (STOP/EJECT)			VPZ30P080FUC	(Silver type)
		(Black type)			46	BPZ30P080FZK	Screw
		AAE1021			47	VPZ30P100FMC	Screw
		(Silver type)					
	18	AAE1027	Knob (PAUSE)		48	BBZ30P120FZK	Screw
		(Black type)				(Black type)	
		AAE1028				BBZ30P120FUC	(Silver type)
		(Silver type)					
	19	AAE1006	Knob (REC)		49	AEB1013	Rubber
		(Black type)					
		AAE1023			50	ABH1008	PAUSE spring
		(Silver type)			51	ABH1010	Sub-spring
	20	AAE1007	Knob (SYNCHRO COPY)		52	ABH1009	Coil spring
		(Black type)			53	AEC-525	Nylon rivet
		AAE1024			54	VMZ30P060FMC	Screw
		(Silver type)					
	21	AAE1008	Knob (REVERSE MODE, REC/PLAY)		55	PMZ20P030FZK	Screw
					56	AZN1109	Synchro spring
	22	AAE1009	Knob (DIRECTION)		57	AZN1108	Synchro operation plate
	23	AAE1010	Knob (VOLUME)		58	AZN1107	Synchro plate
		(Black type)			59	AZN1104	Synchro axis
		AAE1025					
		(Silver type)					

Mark	No.	Part No.	Description	Mark	No.	Part No.	Description
	60	AZN1102	Docking plate		106		Bainder
	61	AZN1103	Knob axis		107		P.C.B Holder
	62	AZN1112	Reinforcement plate		108		P.C.B Support
	63	ANZ1098	Knob holder (R)		109		EQ assembly
	64	ANZ1106	Knob holder (L)		110		MIC assembly
	65	AZB1035	Screw		111		VR assembly
	66	AZB1042	Screw		112		LED assembly (C)
	67	AZB1040	Screw		113		LED assembly (B)
	68	AZN1178	Washer		114		LED assembly (A)
					115		Remain display paper
	101		Cassette mechanism assembly		116		Half pressure spring
	102		Chassis		117		Unit stay
	103		Rear panel		118		Mount plate
	104		Bottom plate		119		Heat sink
	105		AMP bage		120		Heat sink holder

## 6. PACKING

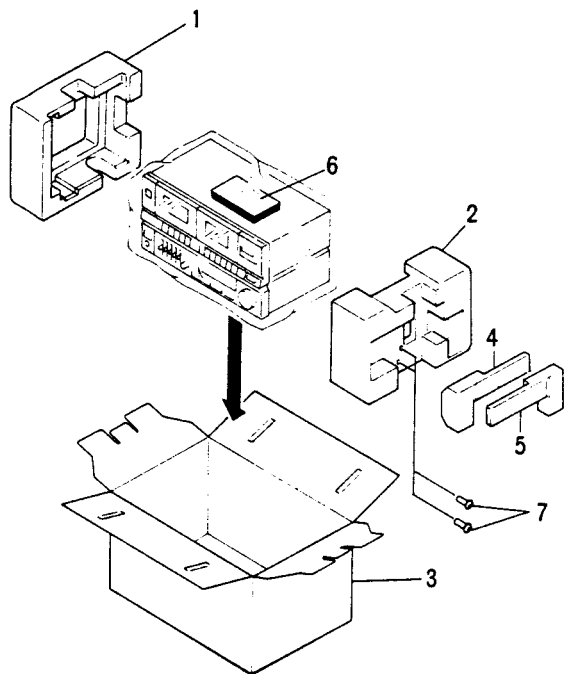

Mark	No.	Part No.	Description
	1	AHA1001	Side pad (L)
	2	AHA1002	Side pad (R)
	3	AHD1001	Packing case
		(Black type)	
		AHD1055	
		(Silver type)	
	4	AMR1060	Player stand (L)
		(Black type)	
		AMR1062	
		(Silver type)	
	5	AMR1061	Player stand (R)
		(Black type)	
		AMR1063	
		(Silver type)	
	6	ARB1001	Operating instruction (English)
	7	ABA1003	Screw

# 7. ELECTRICAL PARTS LIST

**NOTES:**

- When ordering resistors, first convert resistance values into code form as shown in the following examples.
 

*Ex. 1 When there are 2 effective digits (any digit apart from 0), such as 560 ohm and 47k ohm (tolerance is shown by J=5%, and K=10%).*

560Ω    56 × 10<sup>1</sup>    561..... RD½PS 561 J  
 47kΩ    47 × 10<sup>3</sup>    473..... RD½PS 473 J  
 0.5Ω    0R5 ..... RN2H 0R5 K  
 1Ω      010 ..... RS1P 010 K

*Ex. 2 When there are 3 effective digits (such as in high precision metal film resistors).*

5.62kΩ    562 × 10<sup>1</sup>    5621 .... RN¼SR 5621 F
- The  $\Delta$  mark found on some component parts indicates the importance of the safety factor of the part. Therefore, when replacing, be sure to use parts of identical designation.
- For your Parts Stock Control, the fast moving items are indicated with the marks **★★** and **★**.
 

**★★ GENERALLY MOVES FASTER THAN ★**

This classification shall be adjusted by each distributor because it depends on model number, temperature, humidity, etc.
- Parts marked by "⊙" are not always kept in stock. Their delivery time may be longer than usual or they may be unavailable.

**Miscellaneous Parts  
P.C BOARD ASSEMBLIES**

Mark	Symbol & Description	Part No.
	TAPE assembly	GWM-463
	AF assembly	GWM-466
	EQ assembly	Non supply
	MIC assembly	Non supply
	VR assembly	Non supply
	LED assembly (A)	Non supply
	LED assembly (B)	Non supply
	LED assembly (C)	Non supply

**OTHERS**

Mark	Symbol & Description	Part No.
$\Delta$ ★	T1 Power transformer (AC 220V/240V)	ATS-183
★★	FU1 Fuse (T1.25A)	AEK-509
★★	FU3 Fuse (T1.6A)	AEK-510
★★	FU4, FU5 Fuse (T2.5A)	AEK-512
$\Delta$	AC Power cord (AC 240V)	ADG-051

**TAPE Assembly (GWM-463)  
SEMICONDUCTORS**

Mark	Symbol & Description	Part No.
★★	IC501 PRE AMP	BA3416L
★★	IC502	BA3706
★★	IC701, IC702 TR-ARRAY	LB1214
★★	IC703 OP-AMP IC	M5218LF
★★	IC801 W-DECK CONTROL	PDE013
★★	IC601 DOLBY-B IC	TA7719P
★★	IC704 LOGIC IC	TC4052BP
★★	IC503 E-SW IC	μPC1290C
★	D805	RD5.1ESB
★	D701—D707, D801—D803,	1SS131
★	D806—D812	
★	D813	RD3.6ESB

Mark	Symbol & Description	Part No.
★★	Q505, Q506, Q515, Q706, Q707, Q714, Q803—Q805, Q807	2SA1115 (2SA933S)
★★	Q801, Q802	2SA1515
★★	Q501—Q504, Q507—Q512, Q514, Q517, Q518, Q601, Q602, Q703—Q705, Q806, Q708—Q711, Q715—Q718	2SC2603 (2SC1740S)
★★	Q701, Q702	2SD438

**COILS, TRANSFORMER AND FILTERS**

Mark	Symbol & Description	Part No.
	F601, F602 DOLBY Filter	ATF-210
	L701 Inductor	ATH-094
	L704, L705 Inductor	ATH-108
	L702, L703 Inductor	ATH-119
	L706, L707 Trap coil	ATM-037
	T701 Bias oscillator transformer	ATX-043

**SWITCHES**

Mark	Symbol & Description	Part No.
★★	S701 Push switch (HIGH SPEED COPY ON/OFF, NOISE REDUCTION ON/OFF, REC MUTE ON/OFF)	ASG1001

**CAPACITORS**

Mark	Symbol & Description	Part No.
	C701	ACE-133
	C511—C514, C747, C748	CCCSL101J50 (CCDSL101J50)

Mark	Symbol & Description	Part No.
	C751	CCCSL221J50 (CKCSL221J50)
	C501, C502	CCCSL271J50 (CCDSL271J50)
	C803	CCCSL680J50 (CCDSL680J50)
	C705, C706	CCDSL101K500
	C752, C753	CCDSL560K500
	C619, C620	CEASR33M50
	C529, C530, C533, C749	CEASR47M50
	C531, C617, C618	CEASOR1M50
	C505—C508, C601, C602, C730, C731, C750, C804, C806	CEASO10M50
	C532, C613, C614, C625, C746, C801, C536	CEAS100M25
	C535	CEAS101M10
	C534	CEAS101M16
	C623, C624, C711, C712, C732, C733	CEAS2R2M50
	C517, C518	CEAS220M16
	C509, C510, C622	CEAS221M10
	C715, C723	CEAS330M16
	C524, C525, C603, C604, C710	CEAS4R7M50
	C521, C537, C538, C621, C703, C704, C728, C729, C802	CEAS470M16
	C754	CEAS101M10
	C526, C527, C713, C714, C503, C504	CKCYB681K50 (CKDYB681K50)
	C605, C606	CKCYB821K50 (CKDYB821K50)
	C528, C745	CKDYF473Z50
	C707, C709, C735, C736	CQMA103J50
	C702	CQMA123K50
	C717, C722	CQMA123J50
	C522, C523, C708, C741, C742	CQMA153J50
	C609, C610	CQMA182J50
	C716, C738	CQMA183J50
	C519, C520	CQMA273J50
	C724, C725	CQMA332J50
	C515, C516, C607, C608	CQMA333J50
	C611, C612	CQMA472J50
	C615, C616, C718, C719, C720, C721	CQMA473J50
	C539, C540, C734, C737	CQMA682J50
	C726, C727	CQMA683J50
	C734, C737	CQMA822J50

**RESISTORS**

NOTE: When ordering resistors, convert the resistance value into code form, and then rewrite the part no. as before.

Mark	Symbol & Description	Part No.
★	VR703, VR704 Semi-fixed	VRTB6VS223
★	VR802, VR803 Semi-fixed	VRTM6H103

Mark	Symbol & Description	Part No.
★	VR701, VR702 Semi-fixed	VRTM6H104
★	VR501—VR504 Semi-fixed	VRTM6H202
★	VR801, VR804 Semi-fixed	VRTM6H203
	R703, R825, R718	RD1/2PM□□□J
	R521, R540, R621, R733	RD1/4PM□□□J
	R787	
	Other resistors	RD1/8PM□□□J

**AF Assembly (GWM-466)  
SEMICONDUCTORS**

Mark	Symbol & Description	Part No.
★★	IC101, IC102 OP-AMP IC	M5218P
$\Delta$ ★★	IC401 AUDIO IC	STK4171
$\Delta$ ★★	IC402, IC403 REGULATOR IC	μPC78M12H
★★	Q401	2SB1015
★★	Q101—Q108, Q402, Q403	2SC1740S (2SC2603)
★★	Q404	2SD438
★	D401	KZL150
★	D402	RD13EB
$\Delta$ ★	D407—D412	S5566 (11E2)
★	D417	RD5.1EB
★	D102, D103, D415	1SS131
★	D403	1S2471
$\Delta$ ★	D413	4D4B44
★	D416	RD15ESB
	D414	RD16ES

**SWITCHES AND RELLY**

Mark	Symbol & Description	Part No.
$\Delta$ ★★	S103 Push switch (POWER)	ASG-551
★★	S102 Push switch (STEREO WIDE)	ASG1002
★★	S101 Push switch (PHONO, CD, VIDEO, TUNER, TAPE)	SUJ8L22226L
$\Delta$ ★	RY401 Relly	ASR-111

**COILS**

Mark	Symbol & Description	Part No.
	L401, L402 AF Choke coil	ATH-053

**CAPACITORS**

Mark	Symbol & Description	Part No.
$\Delta$	C433 (0.01μF/AC400V)	ACG1002
$\Delta$	C430, C435	ACG-019
$\Delta$	C431, C432	ACH-252
	C101, C103, C110, C112, C405, C406	CCCSL101J50
	C141, C142	CCCSL121J50
	C424	CEASR47M100
	C117, C118, C128, C135, C136	CEASO10M50
	C119, C120, C130, C411, C413, C416, C426, C428, C310, C317	CEAS100M50
	C412, C434	CEAS101M50

Mark	Symbol & Description	Part No.
	C403, C404	CCCSL221J50
	C102, C107, C111, C115, C121, C122, C125, C126, C131, C132, C137, C138, C401, C402	CEAS2R2M50
	C310, C317	CEAS220M16
	C407—C410, C423, C425	CEAS221M25
	C427	CEAS332M25
	C106, C116, C129, C420, C421	CEAS470M16
	C414, C429, C415, C417	CEAS470M25
	C422	CEAS471M6
	C127, C440	CKCYF473Z50 (CKDYF473Z50)
	C139, C140	CKCYB681K50
	C123, C124	CKCYX103M25
	C104, C113	CQMA242J50
	C418, C419	CQMA473K50
	C105, C114	CQMA822J50
	C133, C134	CKCYB391K50
	C108, C109	CEAS470M10

**RESISTORS**

NOTE: When ordering resistors, convert the resistance value into code form, and then rewrite the part no. as before.

Mark	Symbol & Description	Part No.
	R441, R442	RD1/2PMFL100J
	R432, R437, R438	RD1/2PM□□□J
	R419, R420	RD1/4PMFL100J
	R435	RFA1/4PL101J
	R421, R422	RD1/4PMF100J
	R413	RD1/4PMFL222J
	R403—R411, R414, R415	RD1/4PM□□□J
	R416—R418, R424, R425, R426, R428, R429, R430, R434	
	R412	RFA1/4PL101J
	R433	RF1/2PS221J
	R423	RS1LMF681J
	R443, R444	RS2LMF271J
	R431, R436	RS2LMF4R7J
	Other resistors	RD1/8PM□□□J

**OTHERS**

Mark	Symbol & Description	Part No.
	2P Pin jack (OUTPUT)	AKB-093
	6P Pin jack (INPUT, PHONO, CD, VIDEO)	AKB-095
	4P Terminal (SPEAKER)	AKE-109
	Mini jack	AKN-034
	Rivet	AEC-940
	Screw	ABA-271
	Rivet	ACE-525
	Screw (3x8)	BBZ30P080FZK
	Screw (3x6)	PBZ30P060FMC

Mark	Symbol & Description	Part No.
	Screw (2x3)	PMZ20P030FZK
	Screw (3x6)	VBZ30P060FMC
	Screw (3x8)	VBZ30P080FMC
	Screw (3x6)	VMZ30P060FMC

**EQ Assembly SEMICONDUCTORS**

Mark	Symbol & Description	Part No.
	★★ IC301, IC302 AUDIO IC	BA3812L

**CAPACITORS**

Mark	Symbol & Description	Part No.
	C313, C326	CEASR15M50
	C315, C328	CEASR68M50
	C308, C323	CEAS101M10
	C301, C302	CEAS4R7M50
	C309	CEAS470M16
	C305, C318	CKCYB182K50 (CKDYB182K50)
	C307, C322	CKCYB331K50 (CKDYB331K50)
	C303, C320	CKCYB391K50 (CKDYB391K50)
	C312, C325	CKCYB392K50 (CKDYB392K50)
	C304, C321	CKCYB682K50 (CKDYB682K50)
	C306, C319	CKCYX153M25 (CKDYX153M25)
	C314, C327	CKCYX183M25 (CKDYX183M25)
	C316, C329	CKCX393M25 (CKCX393M25)
	C311, C324	CKCYX683M25 (CKDYX683M25)

**RESISTORS**

NOTE: When ordering resistors, convert the resistance value into code form, and then rewrite the part no. as before.

Mark	Symbol & Description	Part No.
	★ VR301 Slide variable resistor	ACU1001
	Other resistors	RD1/8PM□□□J

**MIC Assembly SEMICONDUCTORS**

Mark	Symbol & Description	Part No.
	★★ Q202	2SA933S
	★★ Q201	2SC1740S

**CAPACITORS**

Mark	Symbol & Description	Part No.
	C202	CEASR47M50
	C206	CEAS101M25
	C204	CEAS220M16

Mark	Symbol & Description	Part No.
	C205	CEAS470M25
	C201	CKCYB102K50 (CKDYB102K50)
	C203	CKCYB472K50 (CKDYB472K50)
	C207, C208	CKCYF473Z50 (CKDYF473Z50)

**RESISTORS**

NOTE: When ordering resistors, convert the resistance value into code form, and then rewrite the part no. as before.

Mark	Symbol & Description	Part No.
	All resistors	RD1/8PM□□□J

**OTHERS**

Mark	Symbol & Description	Part No.
	MIC jack (MIC)	AKN-060
	Mini jack (PHONES)	AKN1001

**VR Assembly**

Mark	Symbol & Description	Part No.
	★ VR401 (VOLUME)	ACU1002

**LED Assembly (A) SEMICONDUCTOR**

Mark	Symbol & Description	Part No.
	★★ D101 LED	AEL-443

**LED Assembly (B) SEMICONDUCTORS**

Mark	Symbol & Description	Part No.
	★★ Q901	2SC2603 (2SC1740S)
	★ D904 LED	AEL-382
	★ D902, D903 LED	AEL-424
	★ D901	1SS131

**RESISTORS**

NOTE: When ordering resistors, convert the resistance value into code form, and then rewrite the part no. as before.

Mark	Symbol & Description	Part No.
	All resistors	RD1/8PM□□□J

**LED Assembly (C) SEMICONDUCTORS**

Mark	Symbol & Description	Part No.
	★ D905, D907 LED	AEL-424
	★ D906	1SS131

**RESISTORS**

NOTE: When ordering resistors, convert the resistance value into code form, and then rewrite the part no. as before.

Mark	Symbol & Description	Part No.
	All resistors	RD1/8PM□□□J

**External Appearance of Transistors and ICs**

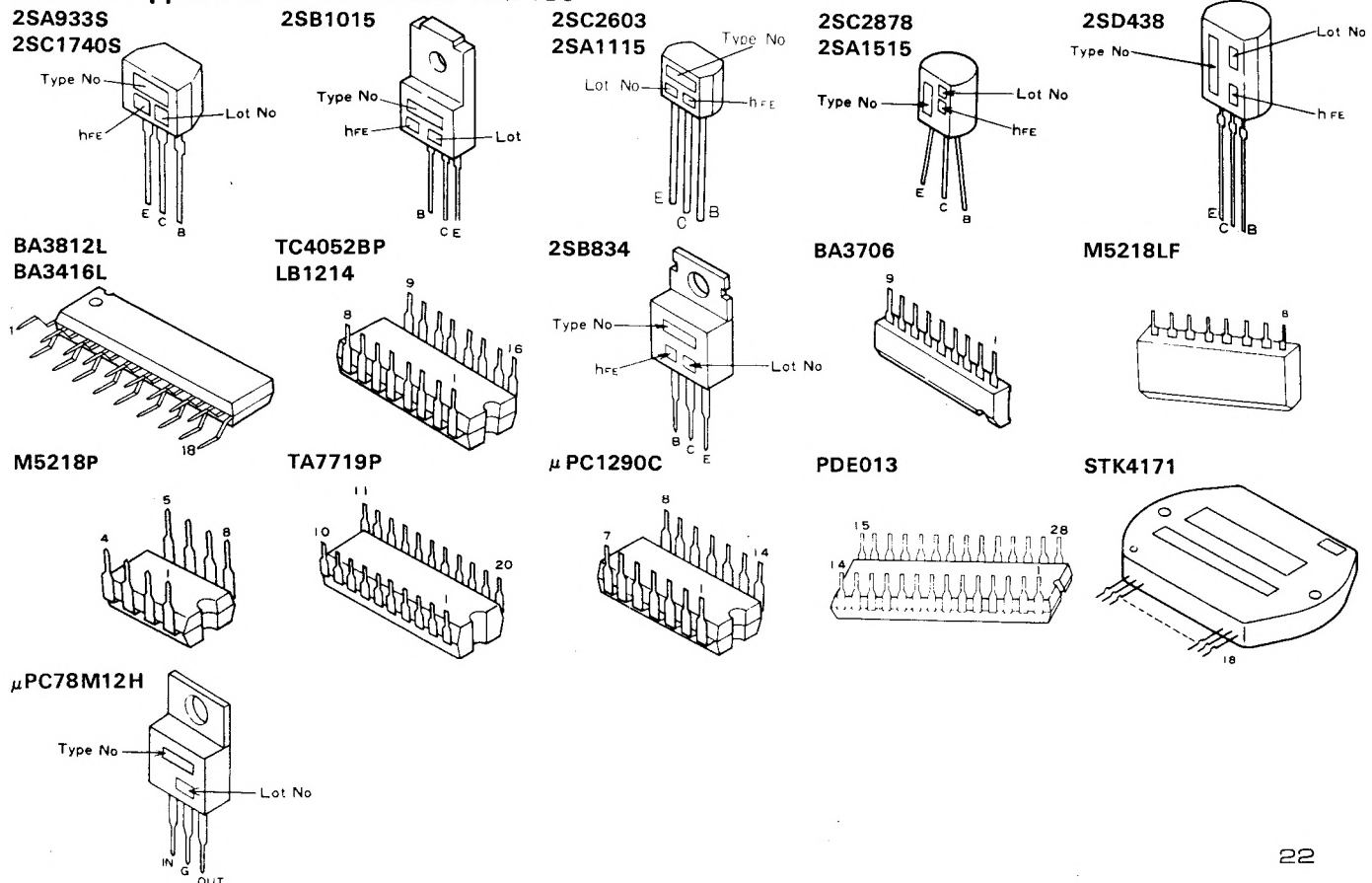





AF ASSEMBLY (GWM-466)

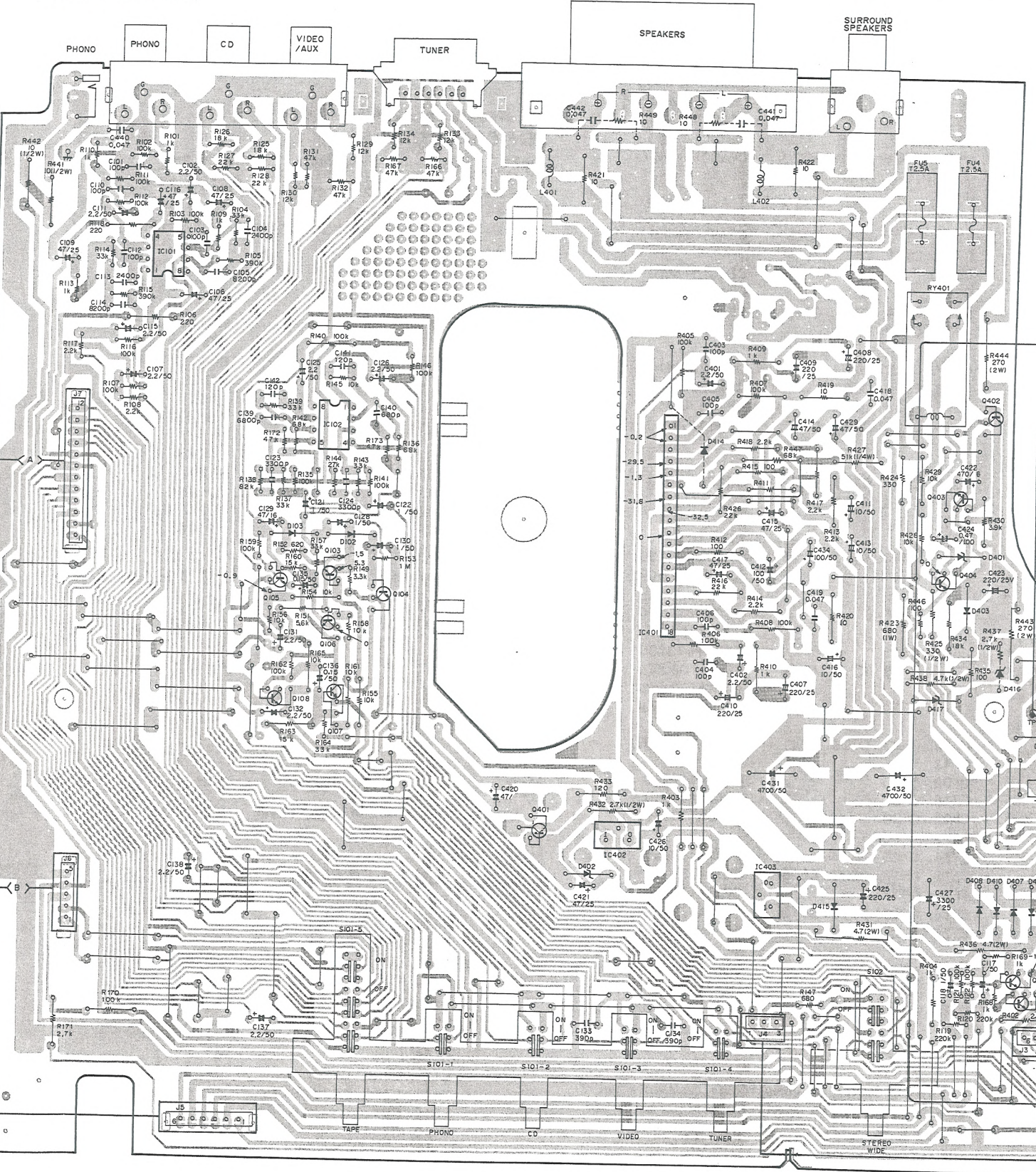

EQ ASSEMBLY

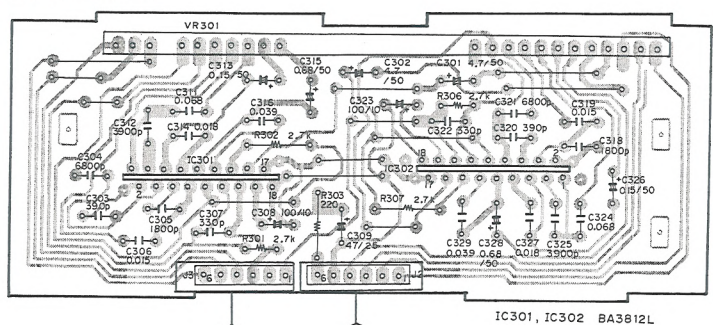

TI POWER TRANSFORMER  
ATS-183

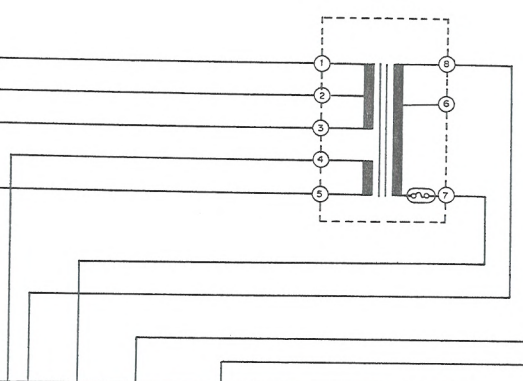

MIC ASSEMBLY

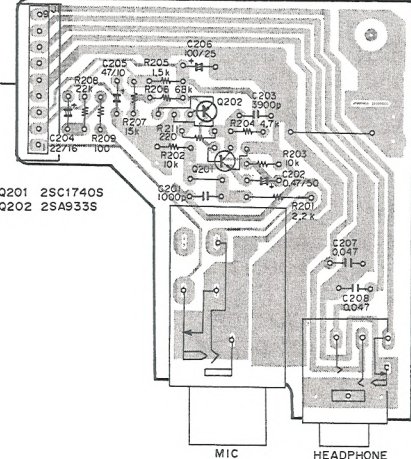

LED ASSEMBLY(A)

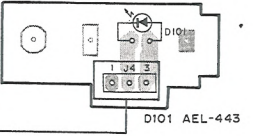

A

B

C

D



NOTE: The indicated semiconductors are representative ones only. Other alternative semiconductors may be used and are listed in the parts list.

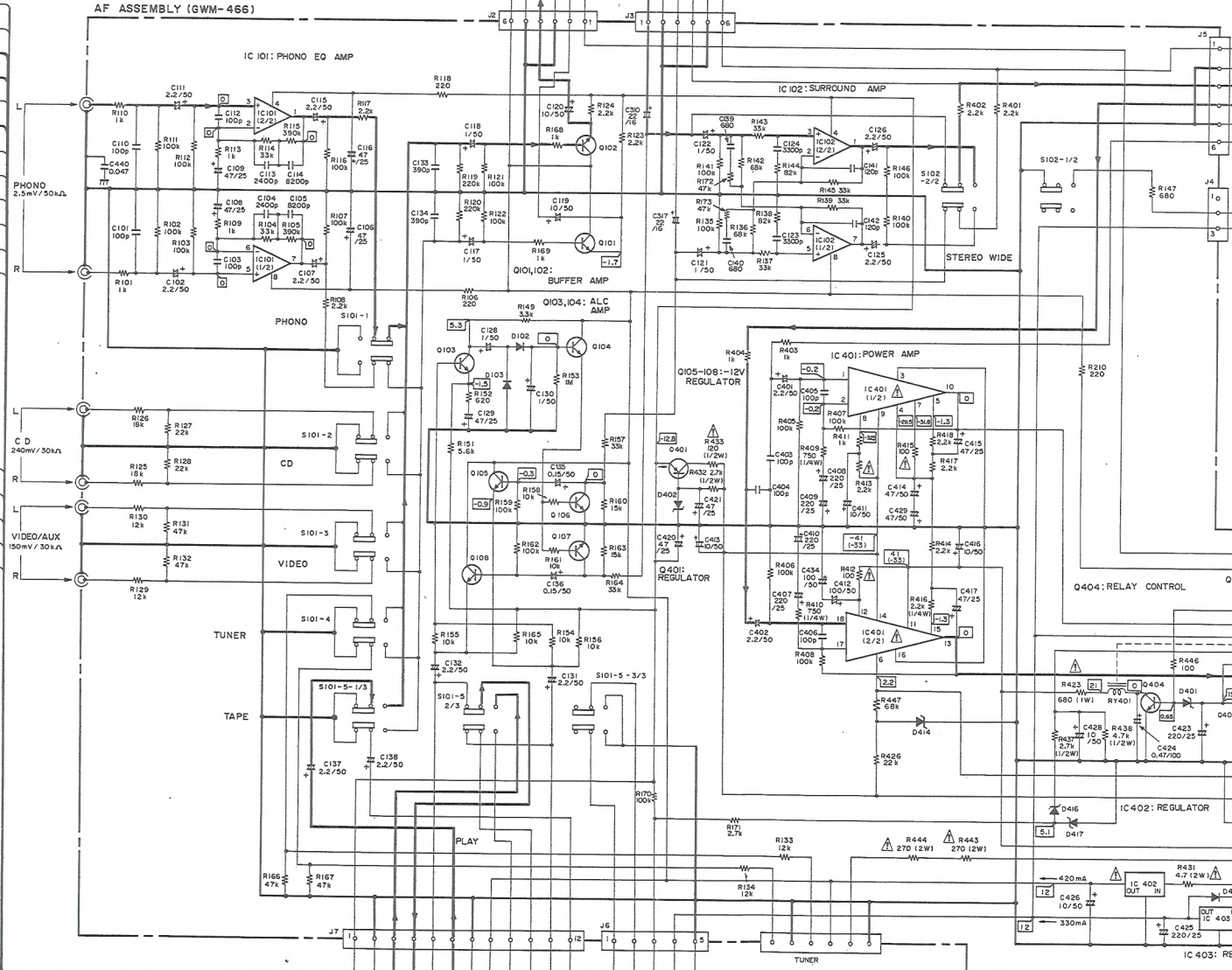
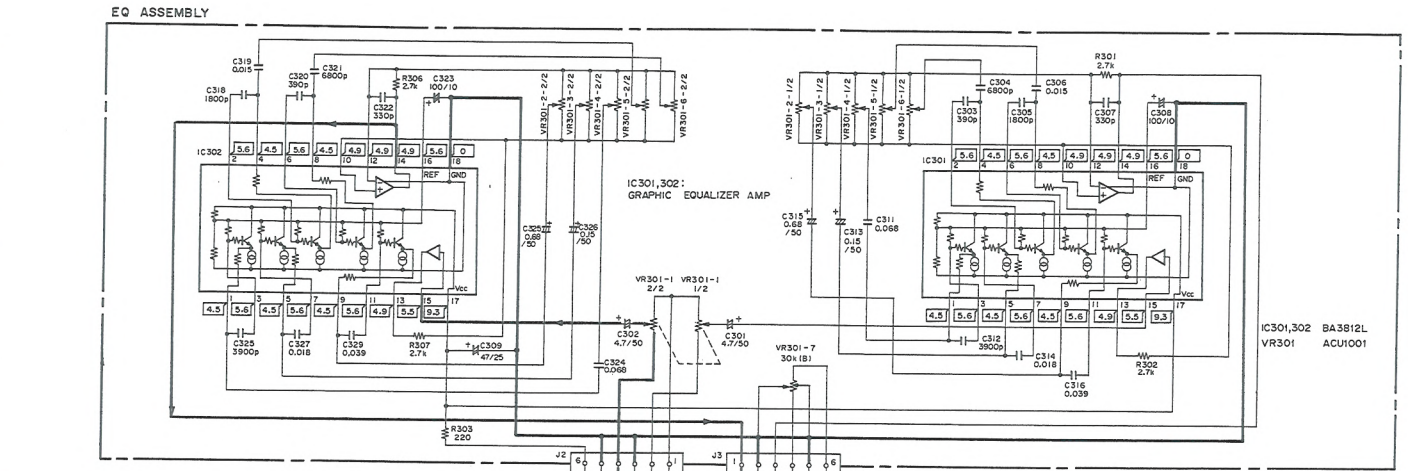
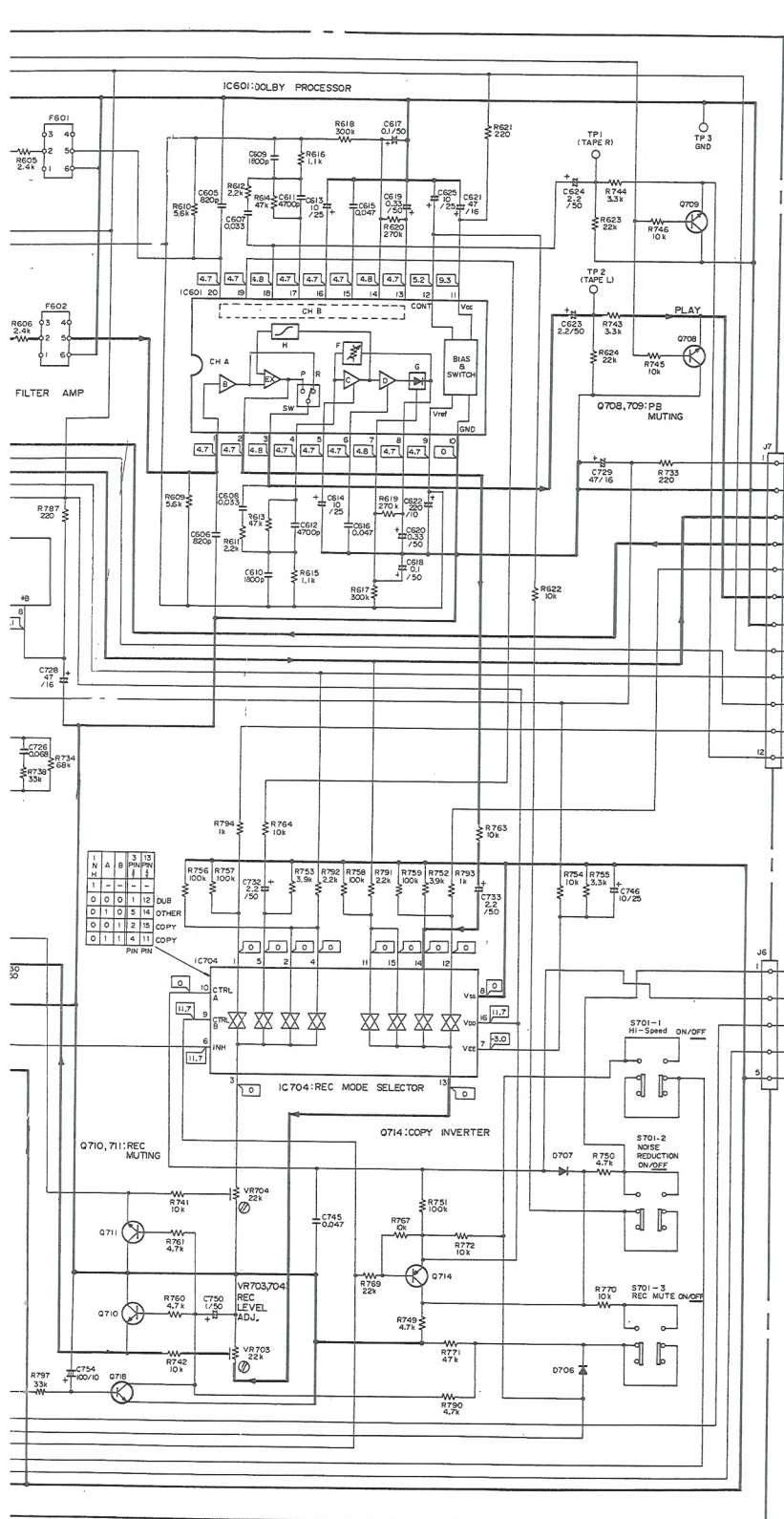

- 1. RESISTORS: Indicated in Ω, 1/4W, 1/6W and 1/8W, ±5% tolerance unless otherwise noted...
2. CAPACITORS: Indicated in capacity (μF)/voltage (V) unless otherwise noted...
3. VOLTAGE, CURRENT: Signal voltage at 50 W + 50 W, 8Ω output (1 kHz)...
4. OTHERS: Signal route, Adjusting point...
5. SWITCHES: THE UNDERLINED INDICATES THE SWITCH POSITION...

Parts list table for AF ASSEMBLY, listing components like IC101, IC401, Q401, Q101-108, Q403, Q404, D401, D402, D403, D404, D405, D413, D414, D415, D416, D417, D418, D419, D420, D421, D422, D423, D424, D425, D426, D427, D428, D429, D430, D431, D432, D433, D434, D435, D436, D437, D438, D439, D440, D441, D442, D443, D444, D445, D446, D447, D448, D449, D450, D451, D452, D453, D454, D455, D456, D457, D458, D459, D460, D461, D462, D463, D464, D465, D466, D467, D468, D469, D470, D471, D472, D473, D474, D475, D476, D477, D478, D479, D480, D481, D482, D483, D484, D485, D486, D487, D488, D489, D490, D491, D492, D493, D494, D495, D496, D497, D498, D499, D500, D501, D502, D503, D504, D505, D506, D507, D508, D509, D510, D511, D512, D513, D514, D515, D516, D517, D518, D519, D520, D521, D522, D523, D524, D525, D526, D527, D528, D529, D530, D531, D532, D533, D534, D535, D536, D537, D538, D539, D540, D541, D542, D543, D544, D545, D546, D547, D548, D549, D550, D551, D552, D553, D554, D555, D556, D557, D558, D559, D560, D561, D562, D563, D564, D565, D566, D567, D568, D569, D570, D571, D572, D573, D574, D575, D576, D577, D578, D579, D580, D581, D582, D583, D584, D585, D586, D587, D588, D589, D590, D591, D592, D593, D594, D595, D596, D597, D598, D599, D600, D601, D602, D603, D604, D605, D606, D607, D608, D609, D610, D611, D612, D613, D614, D615, D616, D617, D618, D619, D620, D621, D622, D623, D624, D625, D626, D627, D628, D629, D630, D631, D632, D633, D634, D635, D636, D637, D638, D639, D640, D641, D642, D643, D644, D645, D646, D647, D648, D649, D650, D651, D652, D653, D654, D655, D656, D657, D658, D659, D660, D661, D662, D663, D664, D665, D666, D667, D668, D669, D670, D671, D672, D673, D674, D675, D676, D677, D678, D679, D680, D681, D682, D683, D684, D685, D686, D687, D688, D689, D690, D691, D692, D693, D694, D695, D696, D697, D698, D699, D700, D701, D702, D703, D704, D705, D706, D707, D708, D709, D710, D711, D712, D713, D714, D715, D716, D717, D718, D719, D720, D721, D722, D723, D724, D725, D726, D727, D728, D729, D730, D731, D732, D733, D734, D735, D736, D737, D738, D739, D740, D741, D742, D743, D744, D745, D746, D747, D748, D749, D750, D751, D752, D753, D754, D755, D756, D757, D758, D759, D760, D761, D762, D763, D764, D765, D766, D767, D768, D769, D770, D771, D772, D773, D774, D775, D776, D777, D778, D779, D780, D781, D782, D783, D784, D785, D786, D787, D788, D789, D790, D791, D792, D793, D794, D795, D796, D797, D798, D799, D800, D801, D802, D803, D804, D805, D806, D807, D808, D809, D810, D811, D812, D813, D814, D815, D816, D817, D818, D819, D820, D821, D822, D823, D824, D825, D826, D827, D828, D829, D830, D831, D832, D833, D834, D835, D836, D837, D838, D839, D840, D841, D842, D843, D844, D845, D846, D847, D848, D849, D850, D851, D852, D853, D854, D855, D856, D857, D858, D859, D860, D861, D862, D863, D864, D865, D866, D867, D868, D869, D870, D871, D872, D873, D874, D875, D876, D877, D878, D879, D880, D881, D882, D883, D884, D885, D886, D887, D888, D889, D890, D891, D892, D893, D894, D895, D896, D897, D898, D899, D900, D901, D902, D903, D904, D905, D906, D907, D908, D909, D910, D911, D912, D913, D914, D915, D916, D917, D918, D919, D920, D921, D922, D923, D924, D925, D926, D927, D928, D929, D930, D931, D932, D933, D934, D935, D936, D937, D938, D939, D940, D941, D942, D943, D944, D945, D946, D947, D948, D949, D950, D951, D952, D953, D954, D955, D956, D957, D958, D959, D960, D961, D962, D963, D964, D965, D966, D967, D968, D969, D970, D971, D972, D973, D974, D975, D976, D977, D978, D979, D980, D981, D982, D983, D984, D985, D986, D987, D988, D989, D990, D991, D992, D993, D994, D995, D996, D997, D998, D999, D1000.

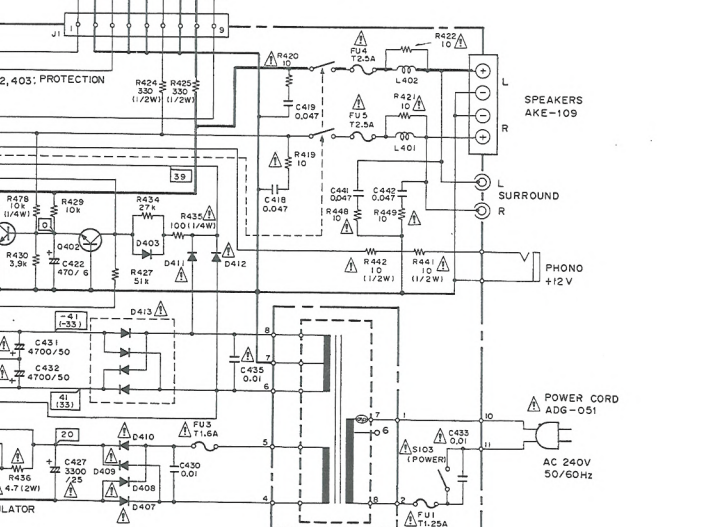
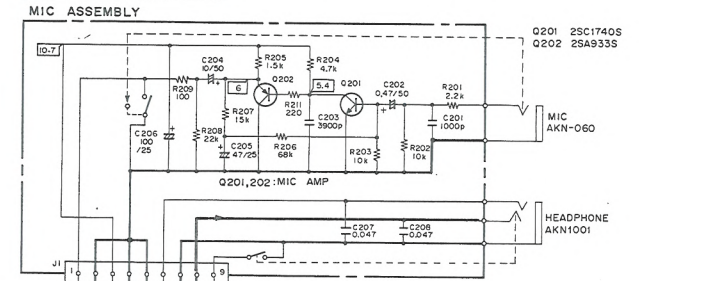

A

B

C

D

# 10. CIRCUIT DESCRIPTIONS

## 10-1. BASIC BLOCKS OF DC-X55Z AND DC-X33Z SIGNAL SYSTEMS

The difference of the two is mainly at the deck section. Table 10-1 indicates the comparative table. As the DC-X33Z is a lower model of DC-X55Z, description will be given mainly on the DC-X55Z.

The signal system basic block is herein indicated so as to comprehend the DC-X55Z signal system from 10-1-1 to 10-1-4.

Table 10-1

	DC-X33Z	DC-X55Z	Remark
Mechanism structure	Single (Mechanism 2 <sup>*1</sup> )	Double (Mechanism 1 <sup>*2</sup> and 2)	*1: Approximately similar to the mechanism 2 of DC-X55Z (REC/PB mechanism) *2: Playback only
Head	E.H and REC/PB H	E.H and REC/PB H... Mechanism 2 side PB H... Mechanism 1 side	
Motor	Rotation number is adjusted by the main body of motor.	Rotation number is adjusted on the board separate from the motor. (Double speed/normal speed)	
Main functions	Copy function	×	○ (Double speed copy is enable)
	Dubbing function	×	○
	Relay play	×	○
	REC MUTE	×	○
Main IC	Control microcomputer	PDE013	PDE013
	Dolby IC	TA7719	TA7719
	Others	×	TC4052BP

\* Is not the DC-X33Z model.

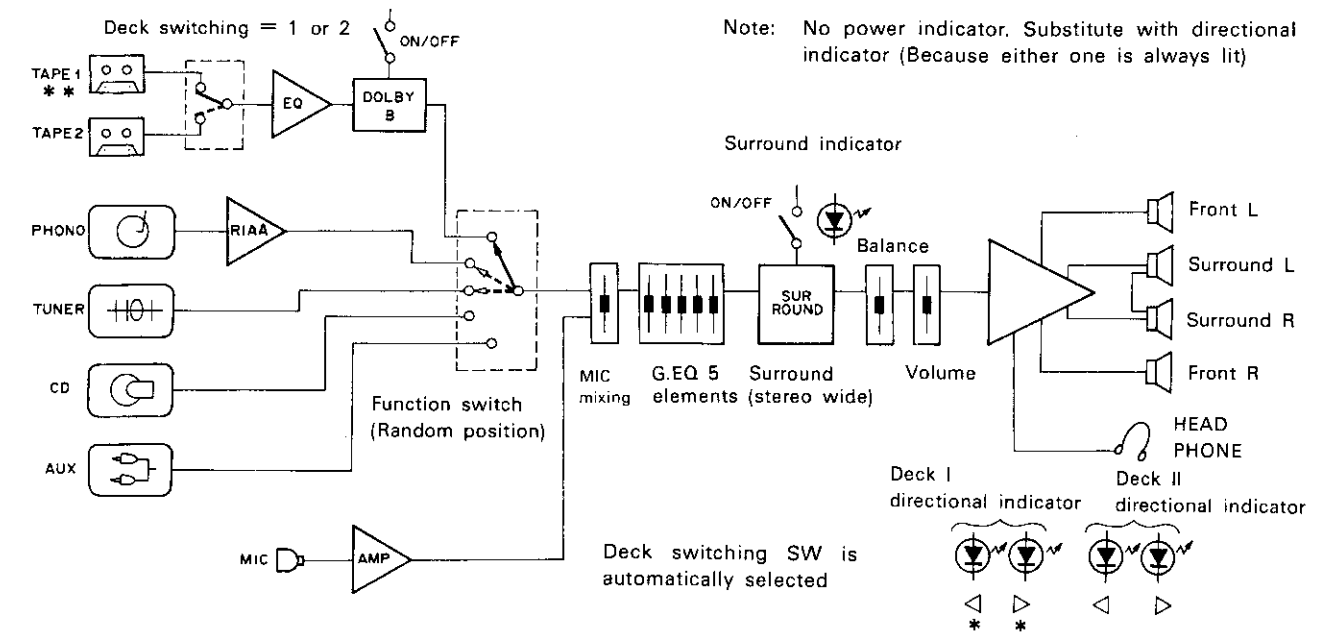

Fig. 10-1-1 Signal system basic block during playback (DC-X55Z, DC-X33Z)

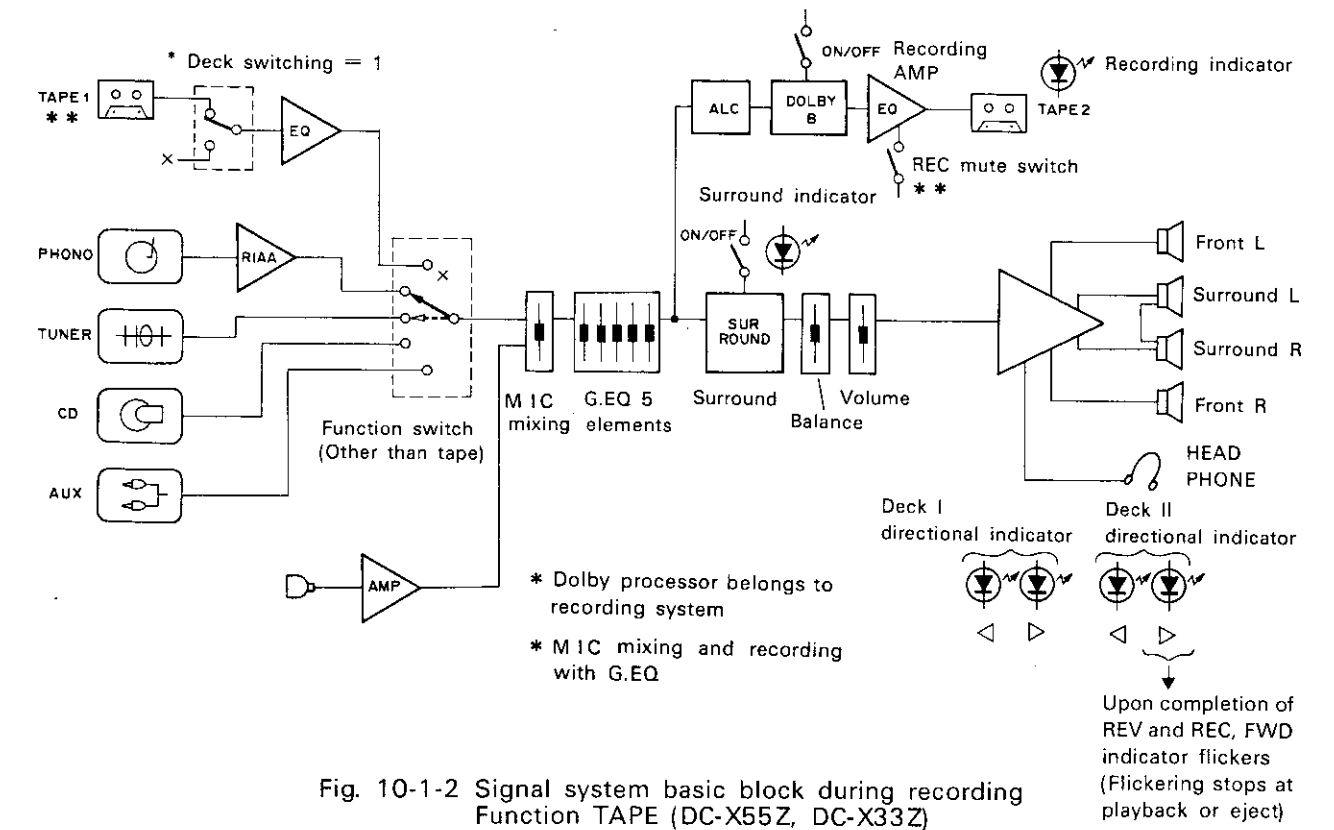

Fig. 10-1-2 Signal system basic block during recording Function TAPE (DC-X55Z, DC-X33Z)

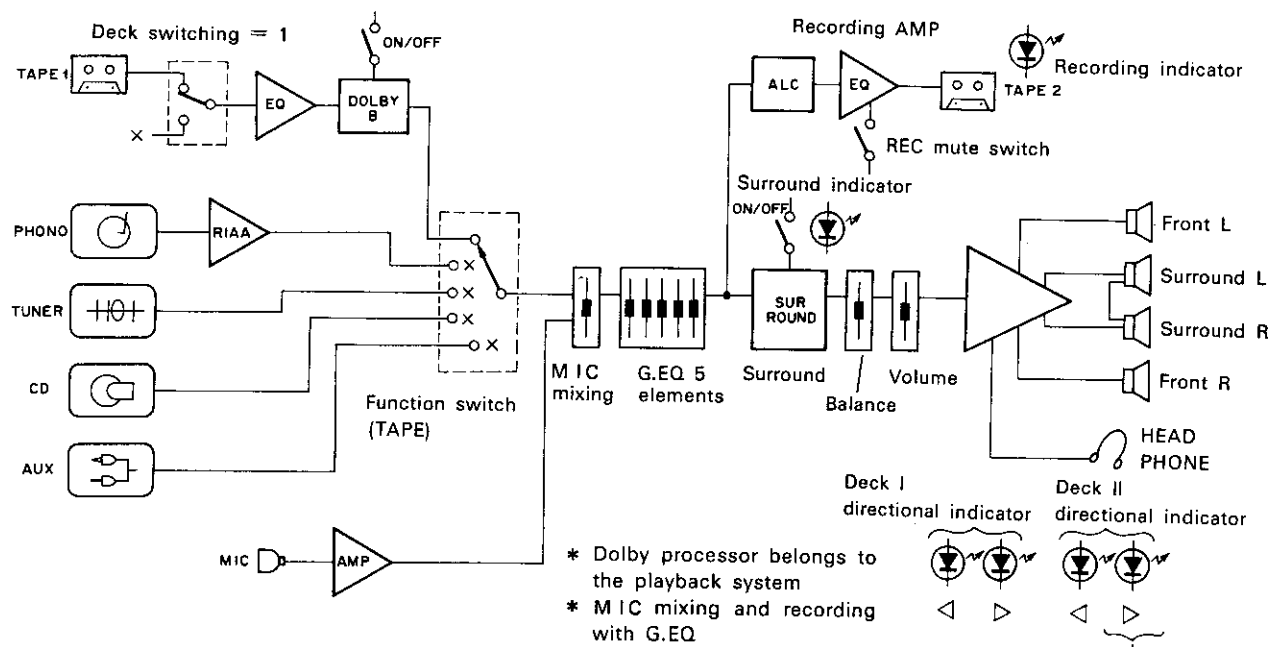
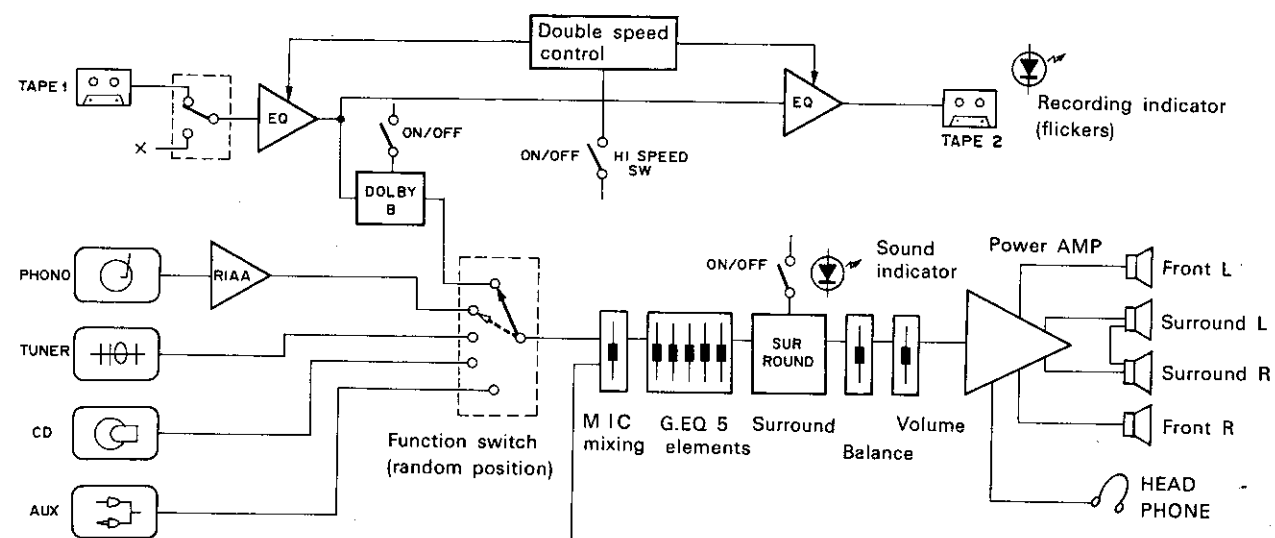

Fig. 10-1-3 Signal system basic block during recording Function TAPE (dubbing) (DC-X55Z only)



- \* Copy mode does not depend on function switch position.
- \* High speed switch is effective only when copy mode is turned on (Ignore the operation of high speed SW after starting copying). Recording indicator flickers during copy.
- \* During normal copying: about 1 to 2 seconds interval.
- \* During double speed copying: about 0.6 second interval.

Fig. 10-1-4 Signal system basic block during copy (DC-X55Z only)

## 10-2. BLOCK DIAGRAM

Fig. 10-2-1 indicates the block diagram of DC-X55Z. Take note that there is no  $\odot$  mark in the Fig. of DC-X33Z.

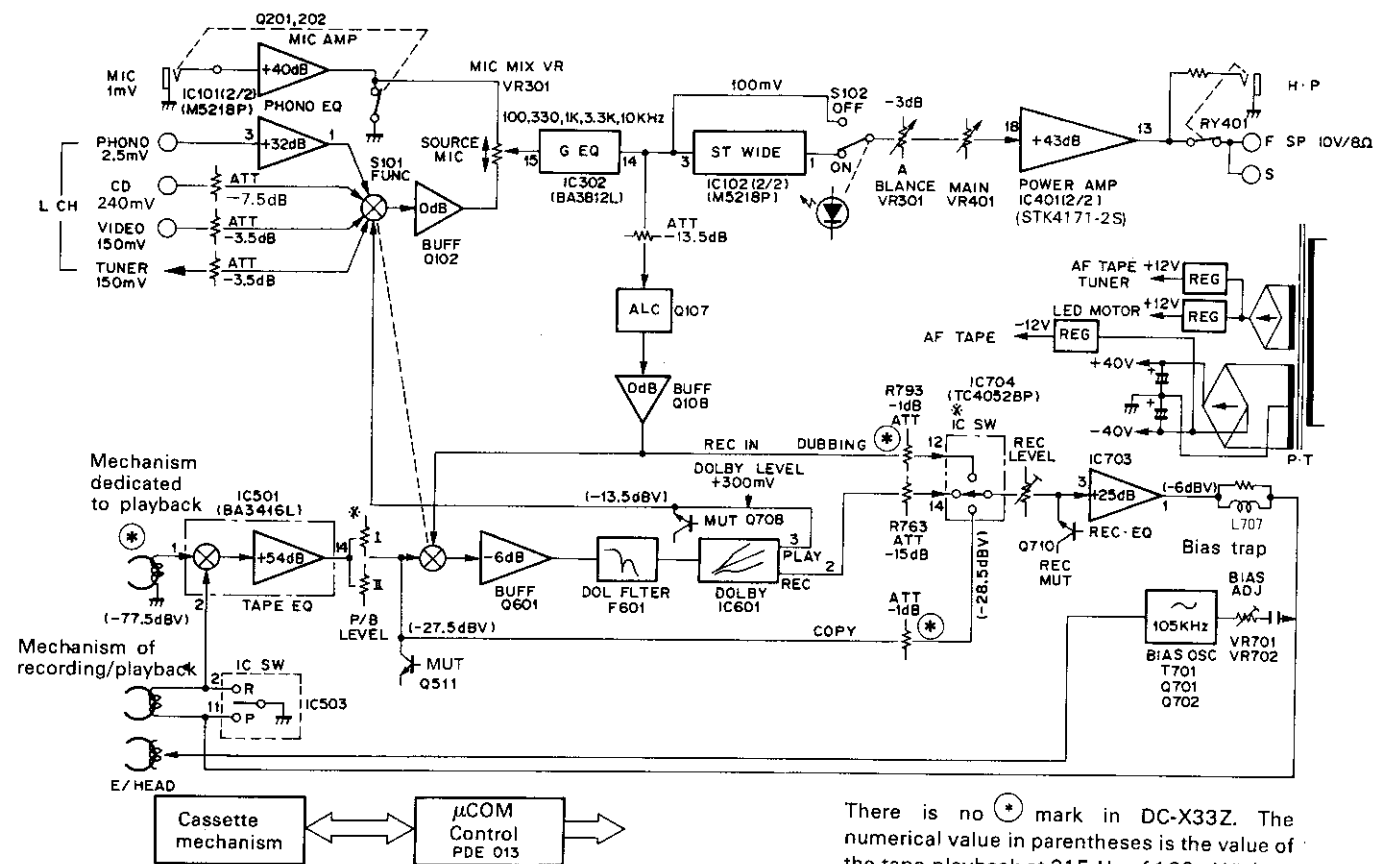

Fig. 10-2-1 Block diagram

The characteristic of this model is that it has only one system in the deck playback system and that this system uses the respective modes of operation separately so that the mechanism 1 does not overlap with the signal system of mechanism 2.

### 10-3. LEVEL DIAGRAM

Fig. 10-3-1 shows the level diagram.

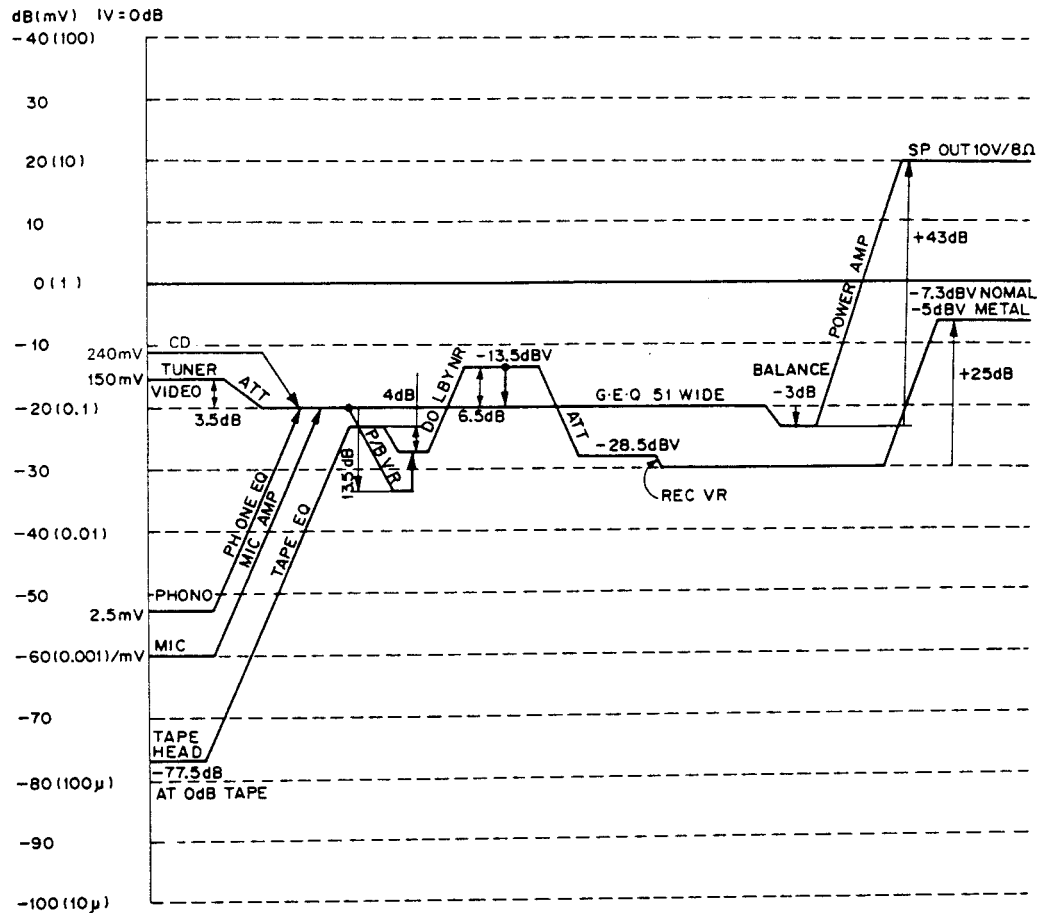

Fig. 10-3-1 Level diagram

### 10-4. SURROUND AND STEREO WIDE CIRCUIT

Fig. 10-4-1 shows the block diagram of the surround and stereo wide circuits.

This circuit leaves the normal component of the medium and low bands as is, and adds the inverse phase to the high and medium band components (There are many reverberal components and ambiance components). In this manner, the normal position of the bass, vocal, etc. become devoid of bad effects, and the sound is heard widening toward the left and right. Also, if a surround loudspeaker is used, one gets the feeling of being surrounded by the sound.

#### Regarding Fig. 10-4-1

1. The input signals of L and R go through a filter which suppresses the respective medium and high band components.
2. Creates an L and R signal component difference and perform addition to the L-ch and subtraction to the R-ch.
3. By performing such calculations, it emphasizes the differential signal components in the medium and high bands in the original source, and obtains a wide sound which is not unnatural (distorted feeling).

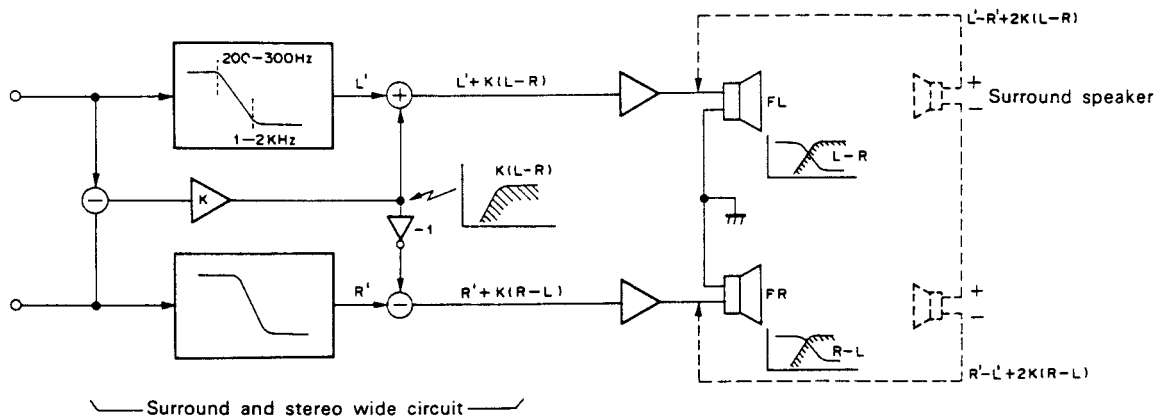
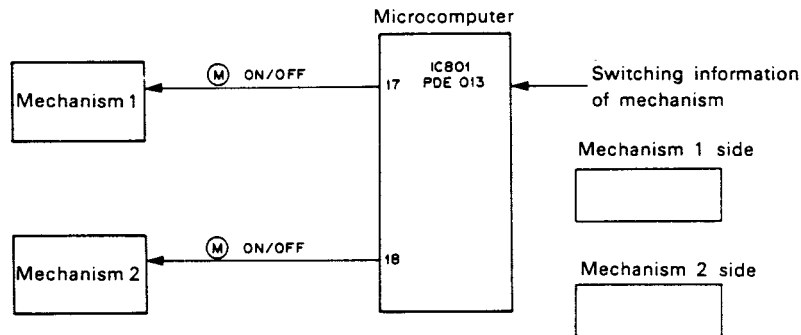

Fig. 10-4-1 Surround and stereo wide circuit block diagram

**10-5. MICROCOMPUTER FOR CONTROL**

The microcomputer IC801 (PDE013) of DC-X55Z gives the on-off commands of the motor only against the mechanism (mechanism 1 and mechanism 2). Also as input, it observes the switch information of the mechanism. The on-off operation of the motor is carried out with this switch information. See Fig. 10-5-1.

In addition, this microcomputer also controls the circuit block (See Fig. 10-5-2). In 2 10-5-3, there is a list of the typical timing chart, pin name and functions.



- \* SW information on the mechanism 1 side
- Main SW → Same as mechanism 2
- Play SW → Same as mechanism 2
- Mute SW → Same as mechanism 2
- First SW → On when the knob of FF or REW is being pressed
- Direction SW → Same as mechanism 2
- Chrome SW → Off when chrome or metal

- \* SW information on the mechanism 2 side
- (Except stop or pause)
- Main SW → On when knob is turned on
- Play SW → On when the play knob is pressed
- Mute SW → On when the head and tape is in contact
- REC SW → On when REC knob is pressed
- Direction SW → On when in reverse playback
- Anti-REC A SW → Off when claw on A side is broken
- Anti-REC B SW → Off when claw on B side is broken
- Mode SW → Off when   display is
- Chrome SW → Off when chrome and metal
- Metal SW → Off when metal

Fig. 10-5-1 Function of control microcomputer

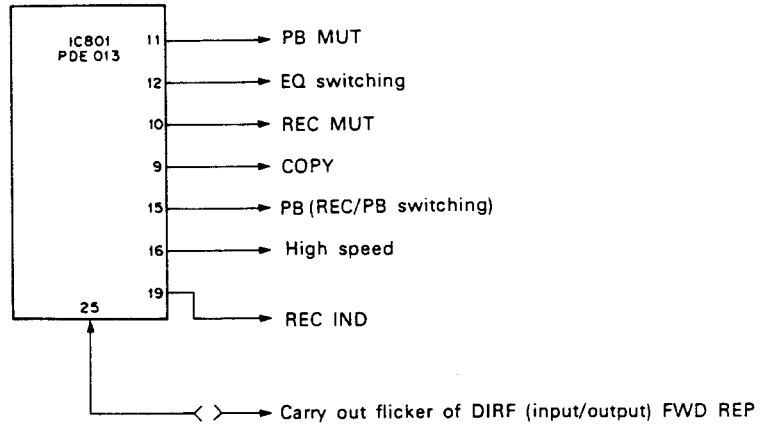

Fig. 10-5-2 Control of microcomputer circuit block dedicated to control

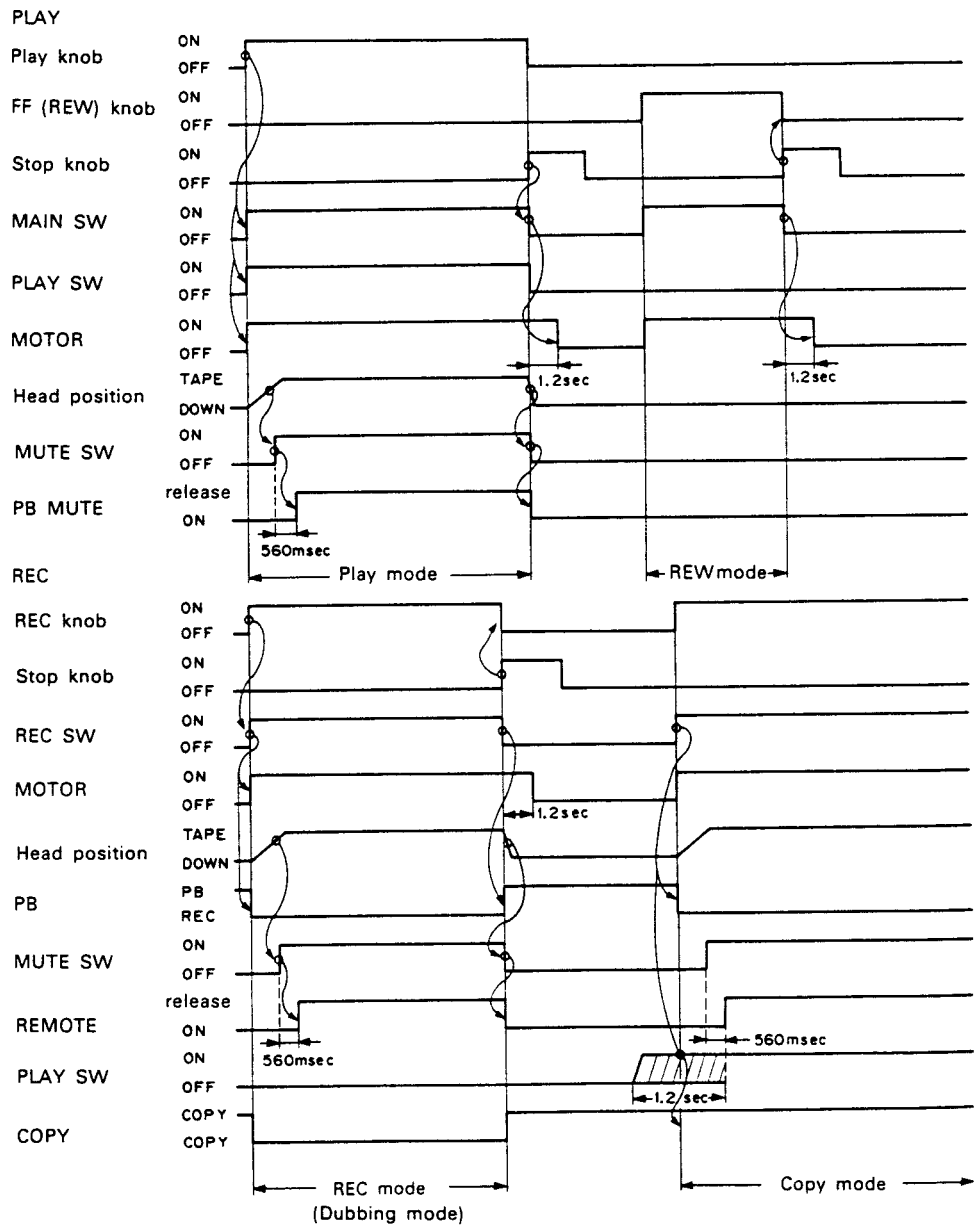

Fig. 10-5-3 (1/2) PDE013 timing chart



## Pin name and functions

Pin No.	Pin name	Input/output of signal	Function
21	ARR	Input	B side erroneous recording prevention claw SW input of mechanism II: "1" when broken.
22	ARF	Input	A side erroneous recording prevention claw SW input of mechanism II: "1" when broken.
23	SYNC	Input	Sync SW input in common: "0" when sync knob is pressed <sup>Note 1)</sup>
24	MAIN (1)	Input	Main SW input of mechanism I: "0" when all the knobs are pressed except stop
25	DIRF	Input/output	DIR SW input and flickering output of mechanism II: "0" when B side is running <sup>Note 2)</sup>
26	DIR	Input	DIR SW input and flickering output of mechanism I: "0" when B side is running
27	MUTE (1)	Input	Mute SW input of mechanism I: "0" when head is turned up
28	PLAY (1)	Input	Play SW input of mechanism I: "0" when play knob is pressed
1	MAIN (2)	Input	Main SW input of mechanism II: "0" when all the knobs are pressed except stop or pause
2	PLAY (2)	Input	Play SW input of mechanism II: "0" when play knob is pressed
3	MUTE (2)	Input	Mute SW input of mechanism II: "0" when head is turned up
4	REC	Input	REC SW input of mechanism II: "0" when REC knob is pressed
7	INT	Input	High speed SW input: <sup>Note 3)</sup>
8	RES	Input	Reset input
9	COPY	Output	Copy output ("0" during REC plus the fact that it is not in copy mode)
10	REC MUTE	Output	REC mute output ("0" when only REC mute is released)
11	MUTE	Output	PB mute output ("0" when only PB mute is released)
12	EQ	Output	EQ switching output ("1" during playback of mechanism I, "0" during playback of mechanism II)
15	PB	Output	Recording/playback switching of mechanism II ("1" during PB, "0" during REC)
16	HISPEED	Output	Double speed switching output ("1" during double speed, "0" during normal)
17	M1	Output	Motor control output of mechanism I ("0" during on)
18	M2	Output	Motor control output of mechanism II ("0" during on)
19	REC IND	Output	Recording IND output ("0" when lit) <sup>Note 4)</sup>

Fig. 10-5-3(2/2) PDE013 pin name and function

\* The output pins are all open collector outputs.

Note 1: Sync SW is not used. In this case, PULL DOWN sync input.

Note 2: Only when DIRF input is 1 (During A side running), it may cause flickering output.

Flickering condition: When it is stopped during recording of REV side.

Flickering condition: When all the knobs are pressed except stop or pause, or when ejected.

Flickering ascertains that the running is in FWD, and does not have any connection with the ordinary operations.

Note 3: Immediately after start of copying, it instantaneously operates as input. The trigger is REC mute output.

During high speed    REC mute    INT  
During normal        High speed SW

Note 4: During REC→lights

During copying

During normal→Repeats flickering at about 1.2 sec interval

During high speed→Repeats flickering at about 0.6 sec interval

**10-6. RELATIONSHIP BETWEEN MECHANISM OPERATION AND CONTROL MICROCOMPUTER**

Before going into the main subject, Fig. 10-6-1 indicates the position and its role of the various SW on the mechanism.

In addition, as the names of "Mode" SW and "Direction" SW are used frequently in this manual, it is recommended that due notice be taken in their relation to the front panel.

a. Figure of mechanism unit seen from front side

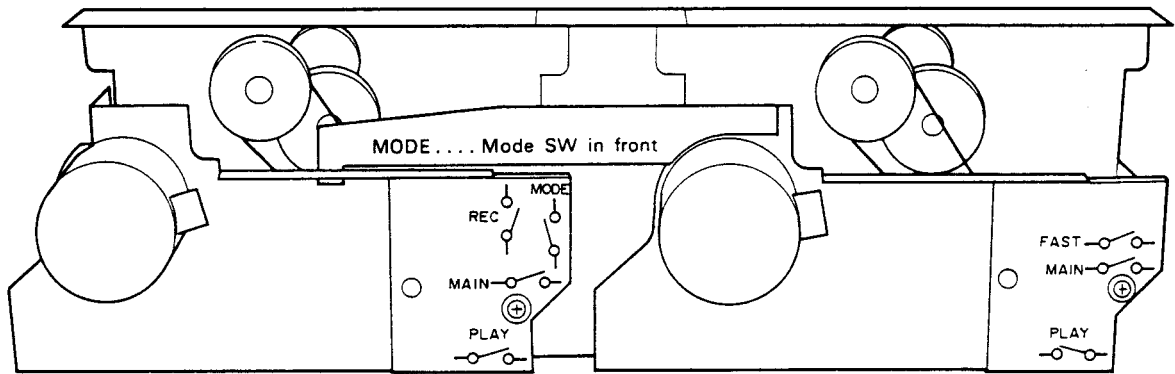
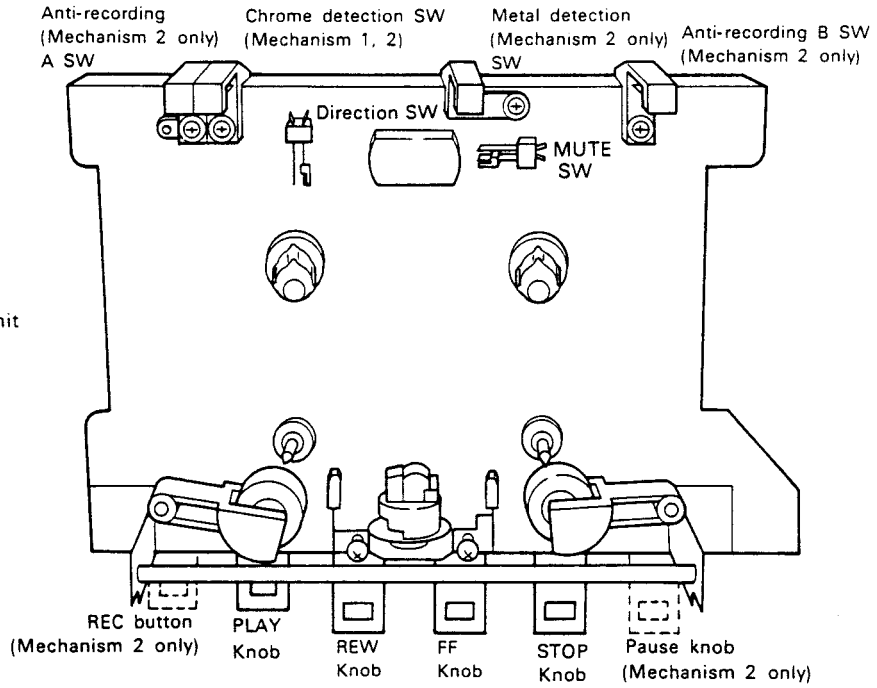

b. Figure seen of mechanism from direction of arrow by opening of bonnet

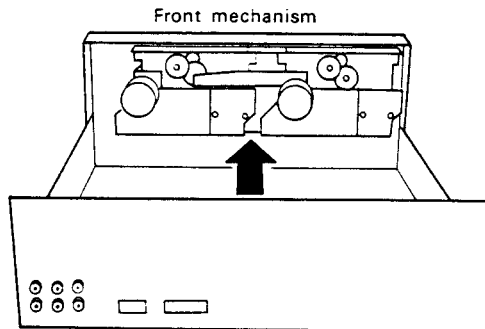

Fig. 10-6-1 Position and role of the various SW

**10-6-1. When Mechanism 1 or Mechanism 2 Operates (Play) Independently**

The microcomputer observes with the main switch, as indicated in Fig 10-6-1(b), as to which knob of the mechanism has been pressed. Against the side of the mechanism of which this switch is on, the signal is output which turns the motor on.

Next, as explained in the block diagram 2, the DC-X55Z has only a single playback amp. Therefore it becomes necessary to make a loop in order to send to the playback amp. the playback signal obtained from the head on the selected mechanism side. These functions are indicated in Fig. 10-6-2.

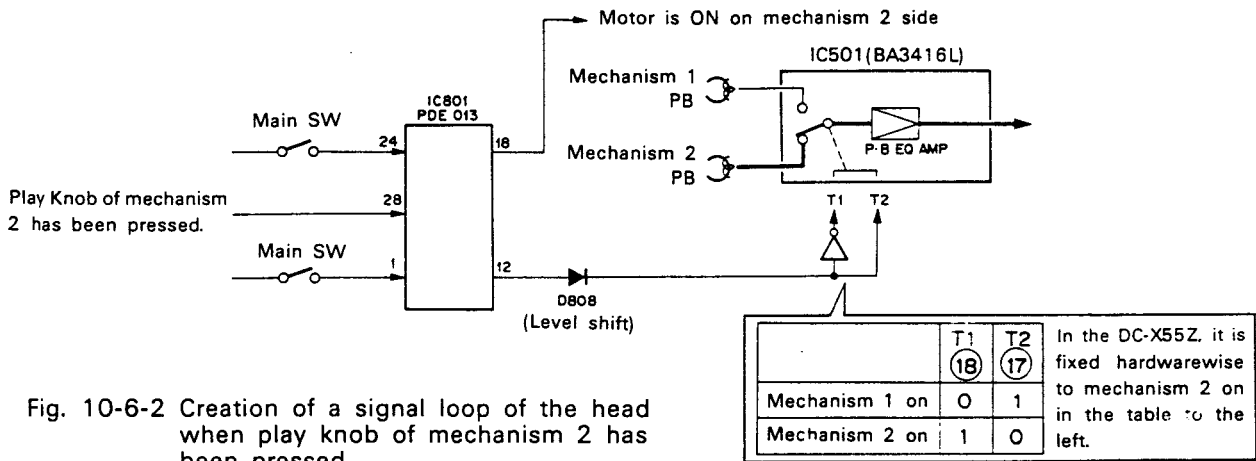

Fig. 10-6-2 Creation of a signal loop of the head when play knob of mechanism 2 has been pressed

**10-6-2. When Mechanism 2 Side Performs REC Operation**

Pin ⑫ output (EQ output) of IC801 (PDE013) is switched to playback of mechanism 1 at "H".

Make pin ⑬ (mechanism 2 recording/palyback switching output) into "L" and induce REC mode. By doing so,

- IC503 is switched to REC mode.
- Make into operation possible state the SW of IC704. (Make to enable)
- Operates the bias oscillator
- Lights the REC IND

The above-mentioned operate and mechanism 2 goes into REC operation.

Moreover, as to the judgment whether it enables the REC operation in practice is judged by the anti-REC SW [See Fig. 10-6-1(a)] alone. (This model is structured mechanically so that the REC knob may be pressed even when the tape erroneous erasure prevention claw is broken. In case the claw is broken, it is so structured that the motor does not rotate and recording may not be performed.)

When reading the anti-REC SW state, it is performed during the start of REC. (The microcomputer does not observe thereafter). These relationships are shown in Fig. 10-6-3.

In Fig. 10-6-3, when the erroneous erasure prevention claw is broken, pins ⑳ and ㉑ of the microcomputer become "H" due to the anti-REC SW being off, and therefore does not become into the REC state.

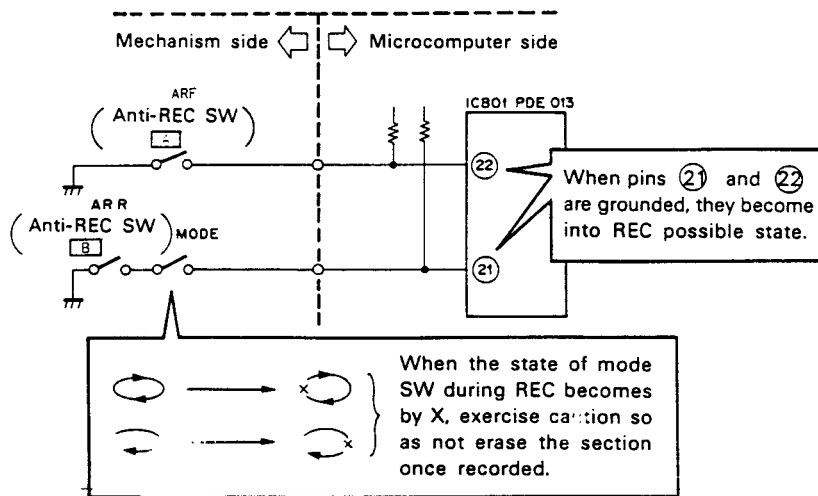

Fig. 10-6-3

### 10-6-3. Relay-play Operation

The DC-X55Z does not have this function.

In order to become into the relay-play operation, it is conditioned that both play switches are on of mechanisms 1 and 2.

It is also so structured that the first played mechanism is always played back on the [A] side. In addition, in accordance with the state of the tape playback mode SW on the front panel, the operation will become as shown in [2] 10-6-4 (According to the example set forth in [2], both mechanisms of 1 and 2 are in the auto-reverse mode.)

In Fig. 10-6-4, the signal which serves as a trigger by detection of tape end and changing tape from [B] to [A] is due to the direction switch which is shown in [2] 10-6-1. (Off when playing back [A] side and on when entering [B] side playback) In accordance with the information of this switch, pins (25) and (26) of the microcomputer change.

When mechanism 1 becomes from [A] side to [B] side and the [B] side becomes end, the microcomputer observes that it is in mechanism 2. At this point, if mechanism 2 awaits at play, make pin (17) from "L" to "H" and stop mechanism 1. Furthermore, make pin (18) from "H" to "L" and play mechanism 2.

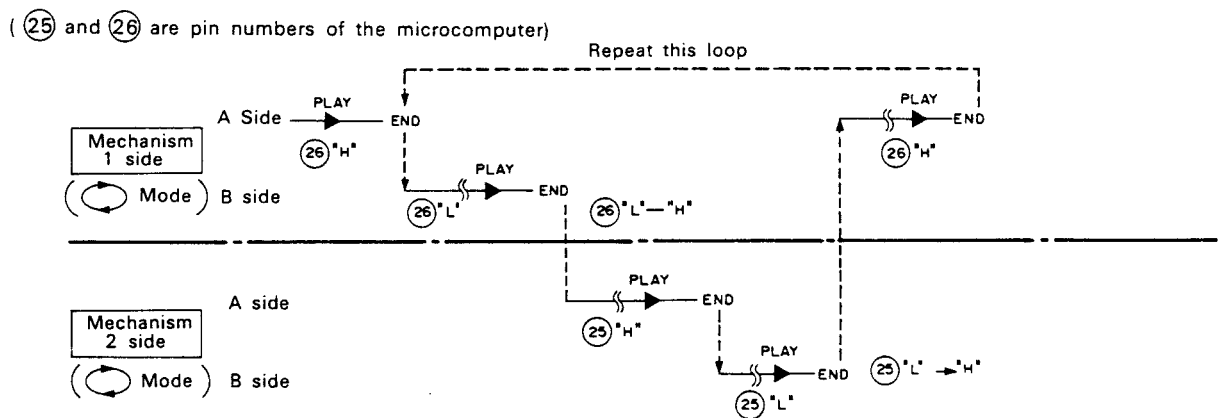

Fig. 10-6-4

### 10-6-4. Copy Operation

Not available for DC-X55Z.

By pressing the sync knob on the front, mechanism 1 becomes into play state and mechanism 2 into REC state. The microcomputer observes this state (When the play SW enters into about  $\pm 1.2$  sec against the REC SW) and judges that it has become into copy mode.

When it becomes into this mode, the microcomputer makes a series of operations as follows:

1. Observes the state of the high speed SW.  
A pulse of approximately  $20 \mu\text{sec}$  is output from pin (10). If this can be read at pins (7) it becomes into high speed recording mode.
2. Set to normal recording or high speed recording.  
High speed recording when pin (16) is "H".  
Normal speed recording when pin (16) is "L".
3. Flickers REC IND.  
0.6 sec cycle during high speed recording  
1.2 sec cycle during normal speed recording
4. Makes mechanism 1 into play, and mechanism 2 into REC. Makes pin (9) to "H".

### 10-6-5. Others

#### Warning against misrecording

In the DC-X55Z, when the recording is cut off on the midst of the [B] side, and then it is desired to continue the recording thereafter on the [B] side the following operation is performed.

1. Turn on PAUSE.
2. Provide for recording state.
3. Provide for [B] side with direction switch.
4. Release PAUSE.

Caution should be exercised because when the recording state is engaged outright, recording will be performed on the [A] side. In order to prompt this caution, this unit flickers the ">" side of "<>" (Pin 25 output of microcomputer)

## 11. MECHANISM OUTLINE

### 11-1. MAJOR SPECIFICATIONS OF MECHANISM

Tape speed	4.76 cm/sec (9.5 cm/sec)	FF and REW torque	Over 80 g·cm less than 200 g·cm
Wow and flutter	0.2% JIS WRMS at 4.76 cm/sec	Back tension torque	3 +2—1 g·cm
FF and REW time	105 ±15 sec	Pinch roller pressing force	220 to 330g
Take up torque	40 +25—5 g·cm	Reverse time at the tape end	Less than 4 sec (PLAY)

### 11-2. OPERATION OUTLINE OF MECHANICAL SECTION

#### 11-2-1. Operation Lever Arrangement

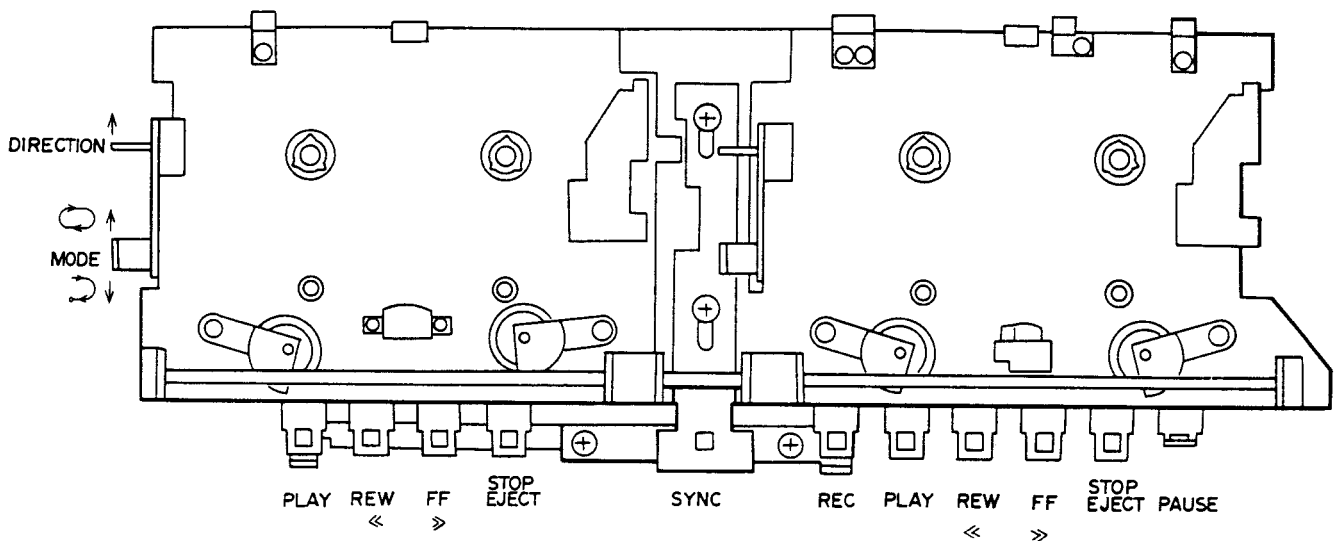

#### 11-2-2. Play

It is put into play mode by the mechanical assist.

#### 11-2-3. REC & Play

##### Play mechanism

1. In the play mode it becomes into <<(REW) or >>(FF), and REV or CUE operation. If it has been in the music selection mode (separate circuit) <<(REW) or >>(FF) is locked and it can be released by the solenoid switch being turned off.

##### REC mechanism

1. When the operation lever of the REC is pressed, that of play is also linked to operate.
2. When in the play mode, if the REC operation lever is pressed, it does not operate.
3. When in >>(REW) or <<(FF) mode, if the REC operation lever is pressed, it does not operate.
4. When in the play mode, if <<(REW) or >>(FF) operation lever is pressed, the play mode is released and it becomes into <<(REW) or >>(FF) single mode.

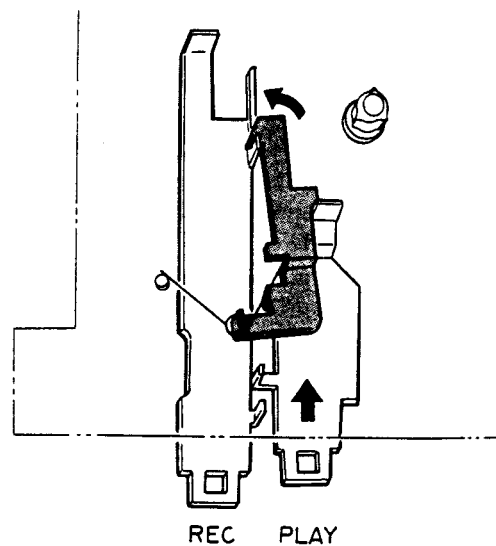

#### 11-2-4. << & >> (REW & FF)

1. It becomes into the REW & FF against the FWD mode and becomes the FF & REW mode against the REV mode.
2. Direct lever pressing <<REW to >>(FF) or from >>(REW) to <<(FF) is not permissible. Be sure to press the lever once via the stop operation.

#### 11-2-5. Stop/Eject

1. Releases the lock of other operation plates. (Except for PAUSE)
2. When the other operation plates are not locked, press the latch lever.
3. When the head board is in the sufficiently advanced state, the STOP plate cannot be inserted even when the other operation plates are unlocked. (The above-mentioned situation is conceivable when the power switch becomes off during the play mode and thereafter the stop operation is performed and the carrying out of the eject operation is intended.)
4. The state of the PAUSE plate has no relations to the operation of the STOP/EJECT plate.

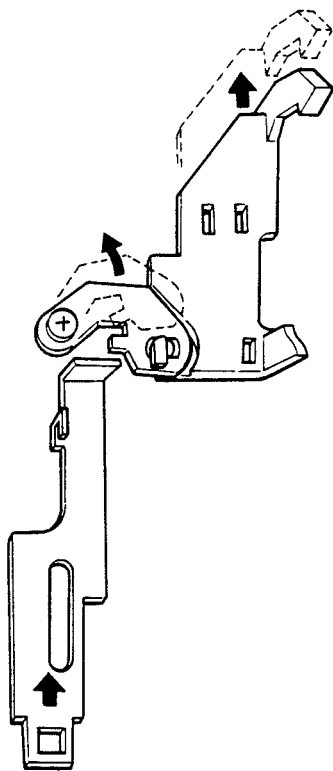

#### 11-2-6. Pause

During the REC or play mode, it can be turned into the pause mode by pulling back the head board a little.

#### 11-2-7. Direction

1. When the operation is performed during the REC or play modes, the tape running direction changes to FWD → REV or REV → FWD.
2. This operation is prohibited when it is not in the REC or play mode.  
See the description of "DIRECTION".

#### 11-2-8. Mode

1. In the mode of ⤴, the tape running direction is automatically changed at the tape end of the FWD or REV and this operation is repeated.
2. In the mode of ⤵, the tape running direction becomes REV at the tape end of FWD and automatically released at the tape end of REV.
3. During << or >>, the tape running directions are automatically released at the respective tape ends.  
See the description of "MODE SELECTION".

#### 11-2-9. Head Rotation

The deviation of the "slide plate ⑧" to the right or left corresponds to the head rotation and the selection of "pinch arm assembly R ⑤⑥" and "pinch arm assembly L ③⑥".

2. During the stop mode (the state in which none of the operations are being carried out), the head board is positioned at the furthestmost back.  
The "slide plate ⑧" is drawn to the right direction by "spring ⑨". This is specified as the FWD standby state.  
The "collar ⑩" of the slide plate contacts with the A section of the U shaped slot of the board. Therefore, the head does not rotate completely and, accordingly, it provides a clearance in the azimuth adjusting section B. This is provided to prevent the shock caused when switching of the REV → FWD mode.
3. When the head board is advanced the "collar ⑩" moves to the C section of the U shaped slot. Since this section is larger than the A section, the "slide plate ⑧" is further pulled to the right direction and the head rotation is regulated by the azimuth adjusting section B via the "head gear B ⑪".  
At this point, there is a clearance provided between the "collar ⑩" and the board C section.

- When the "reverse A ③②" is rotated, the "collar ⑩" is shifted to the left via the "pinch pressure lever caulking assembly ⑲". The shifting amount is in degree to the making of a clearance between the "slide plate ⑧" and the projection D of the "head gear B ⑪". As a result, the head is rotated until it contacts with the azimuth adjusting section E by the pressure of the "head gear spring ⑤". As the head board advances, the "collar ⑩" is supported by the F section of the U shaped slot of the board, and maintains the state in which it is drawn to the left, and becomes in REV mode.

- In the stop mode, move the G section of the "reverse A ③②" in the direction of arrow by hand as shown in Fig., and the operation condition can be found. Moreover, the head board can be advanced to observe the condition with the H section. Finally, be sure to confirm that the head board has completely been recoded.

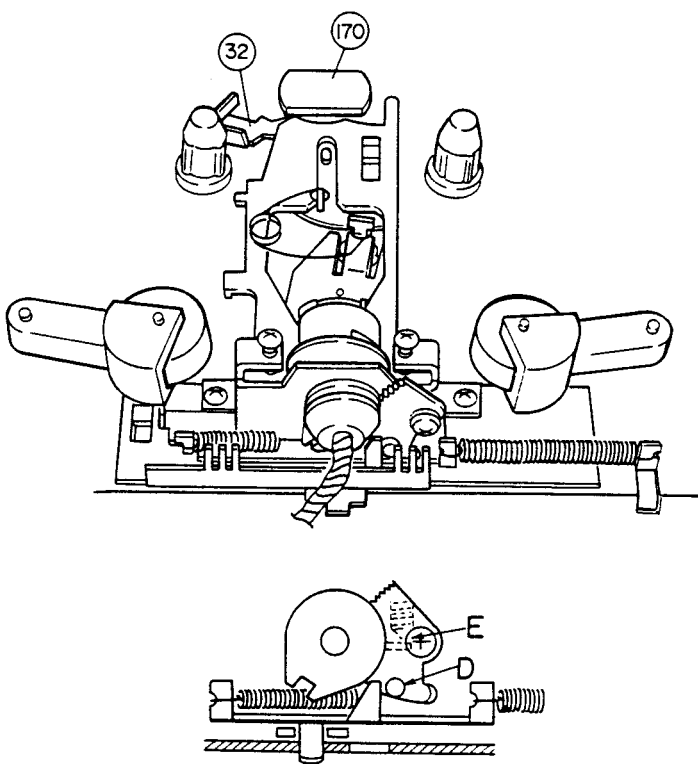
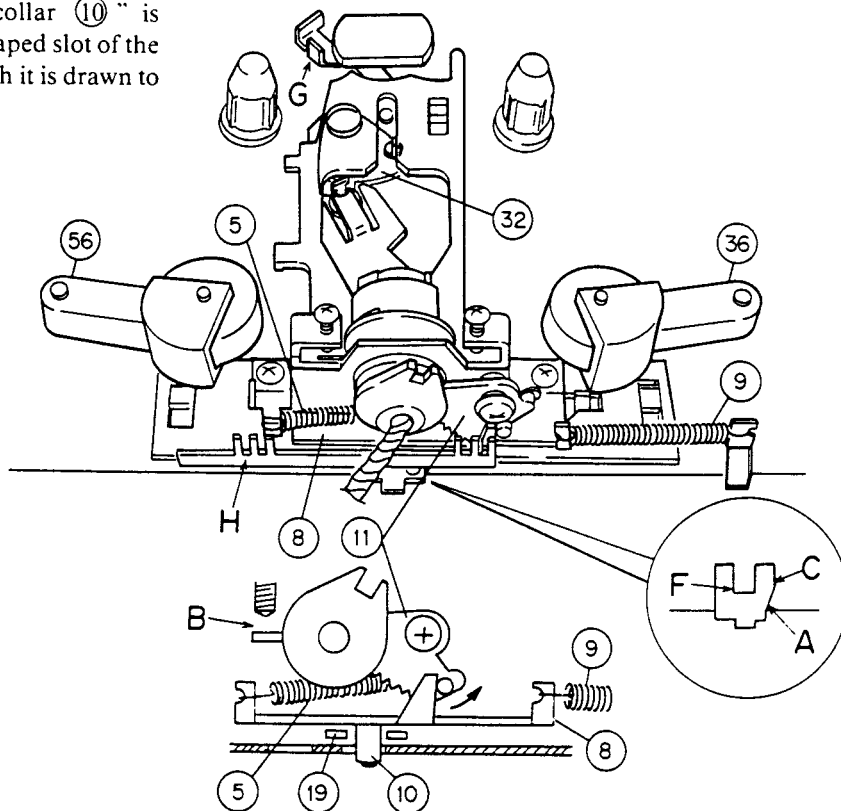

**11-2-10. FWD Priority**

- Once the stop operation is carried out, the next REC or play operation is started from the FWD mode. When pause is required in the process of REV mode, perform pause operation.
- The aforementioned head rotation operation is carried out by every half rotation of the "reverse cam ⑰⑩". It becomes into the FWD mode after a short pin has passed through and the REV mode after a long pin has passed through.
- If the stop operation is carried out from the REV mode, the head board is receded and it becomes into the FWD standby mode as mentioned previously.
- The "reverse A ③②" is also returned at this point; however, the long pin of the "reverse cam ⑰⑩" is being pushed a little. Consequently, the "reverse cam ⑰⑩" turns a half rotation immediately or immediately after the motor is activated again to synchronize with the FWD mode related to the head board.

### 11-2-11. Play Assist

1. When the "play plate (156)" is inserted, it sets the "assist arm (165)" free and rotates the "assist gear (167)" a little by the force of the "trigger returning spring (166)".

The assist gear becomes engaged with the gear of the flywheel and it turns nearly one rotation and when it arrives at the notch of the gear, it is stopped by the top section of the assist arm.

A cam is formed on the other side of the assist gear and the "auxiliary plate (26)" is pushed up alongside the cam face and pulls up the "head board (15)" through the "spring (14)".

2. The "idler gear (30)" is attached to the "idler gear plate (31)" and the selection of the FWD and REV modes are capable by the "inverse spring (18)". The transmission of the take-up torque to the reel table becomes possible by advancing the head board.
3. When the "play plate (156)" is returned by the stop operation, etc., the "assist arm (165)" is also returned and the "assist gear (167)" becomes free and it is receded together with the "head board (15)" and the "auxiliary plate (26)" by the head returning spring (28)".

### 11-2-12. Reverse Auxiliary Plate

During the REV mode, the "idler (30)" receives the pushing back force in relation to the rotation direction. When the head board advances, the edge of the "idler plate (31)" is held to prevent it from being pushed back.

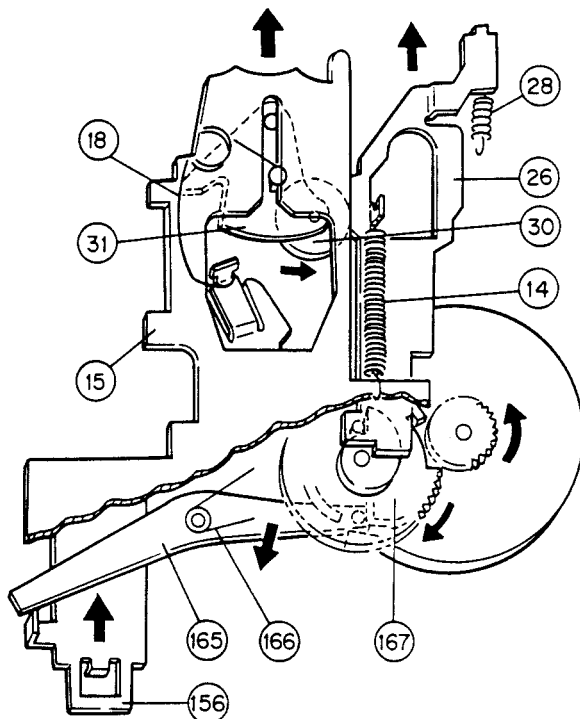

### 11-2-13. Direction

1. Switching of the FWD and REV is carried out by every half rotation of the "reverse cam (171)". (Refer to item 9 and 10) The "reverse gear (129)" is connected to this across the board.

There are two V shaped concave section which face each other at 180° on the cam face closer to the inner circumference of the "reverse gear (129)". In addition, two V shaped convex sections face each other at 180° on the cam face closer to the outer circumference of the said gear. The outer circumference has 2 notch sections.

2. The tip pin section of the "DR lever (122)" is engaged with the concaved section of the reverse gear cam face by "spring (121)" to fix the gear position. At this position, due to gear notching section, it is not engaged with the "tension pulley (127)" which is always rotating at a low speed.
3. When the operating edge of the "DR lever (122)" is drawn toward you, the pin section comes out from the concaved section of the cam face and strikes against the sloped face of the concave and rotates this reverse gear a little.
4. Accordingly, the gear engagement is started and the reverse gear rotates only by half rotation.
5. The shift operation of the "DR lever (122)" is so designed as to prohibit the play plate from being inserted relative to the A section and the "play plate (156)".

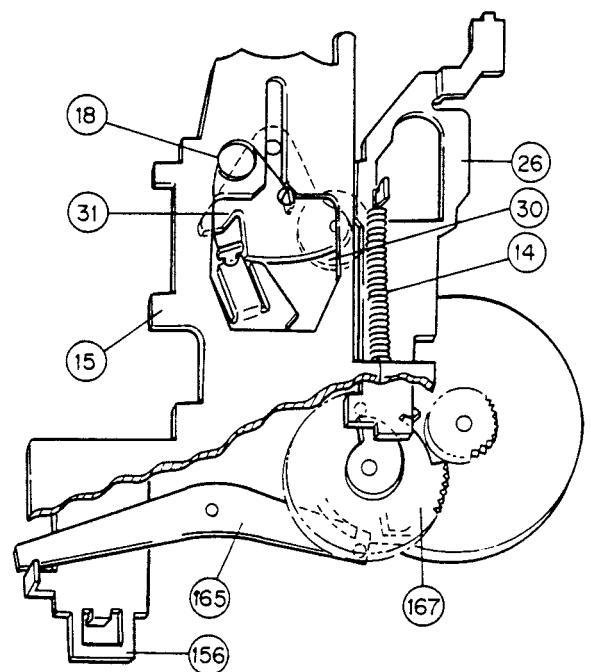





**11-2-14. Automatic**

1. On the lower part of the "reel tables (61) and (62)", there is a pin which is connected to them by a small torque to rotate together.
2. The pin contacts against the short branch of the "detection prevention lever (138)", and while the FWD side reel table is rotating in the FWD direction, it receives the force in the direction of arrow.
3. A pin is inserted into the square shaped slot of the "detection lever (119)", and it is moved in the direction of arrow during the rotation to REV direction by this pin, and during the rotation to the FWD direction by the detection prevention lever.
4. To the "tension pulley (127)", which is always rotating at a low speed, a stepped cam is provided close to the center and a eccentric circumferential shape cam is provided close to the outside. The wall section A in the top section of the "detection lever (119)" is inserted to the concave section between those two cams.

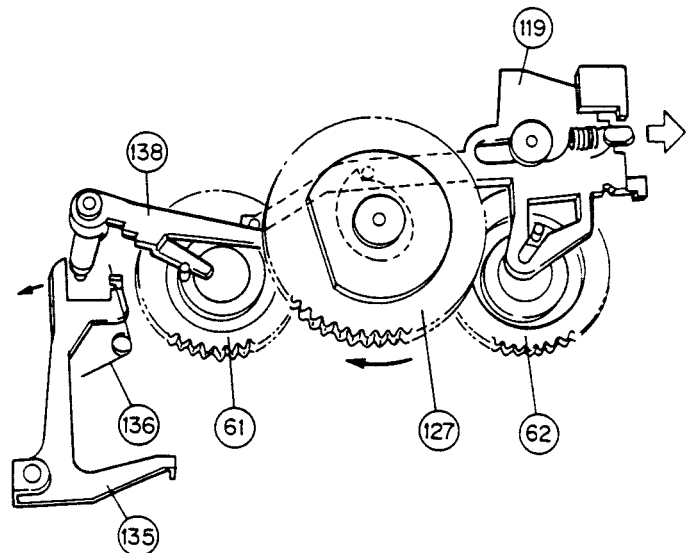
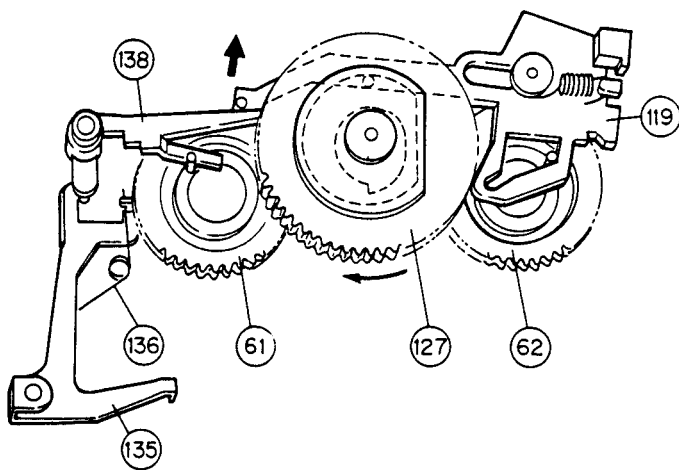
5. During rotation of the reel table the A section, within the cam groove, always totteringly tends to go outward alongside the 1 circumferential cam surface.
6. When the reel table is suspended, as the force to go outward becomes dormant, the A section is drawn inward by the outer circumference cam surface. Thereafter it stays as is and collides with the staircase of the inner cam. By moving it in the direction of →, it performs automatic operation.
7. The eccentric force is applied to the "detection prevention lever (138)" so that the automatic operation does not activate while the "detection prevention plate (135)" and "spring (136)" are in stop or pause modes.



### 11-2-15. Mode Selection

1. The movement of the "detection lever (119)" in the arrow direction is transmitted selectively to the A section of the "DR lever (122)" or the B section of the "release lever (117)". When it is transmitted at the DR lever, it becomes the direction selection and to release lever, it becomes into automation release.
2. The "detection lever (119)" is installed at the section of (119-2). When (119-2) section slides to the A direction, it becomes the DIRECITON (continuous) and to the B direction, it becomes the automatic release (one round trip and then stops).
3. The "stopper plate B (148)" acts when in the << or >> operation and makes it into the end automatic release preferentially.  
When setting the "mode lever (123)" to , the next one becomes the DIRECTION selection (continuous mode) with first priority.  
When setting the "mode lever (123)" to , it becomes selection during the FWD mode and automatic release during the REV mode.
4. The "spring (124)" is a weak spring. It is required that the sliding is carried out lightly.

### 11-2-16. Others

It the play operation is carried out when the power switch is turned off, there may be cases in which the assist gear is still engaged. When the power switch is turned on, it becomes the following mode after once passing through the play mode.

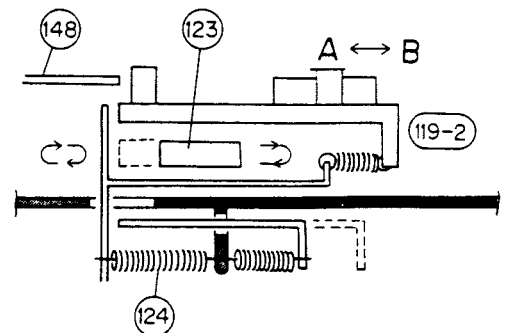
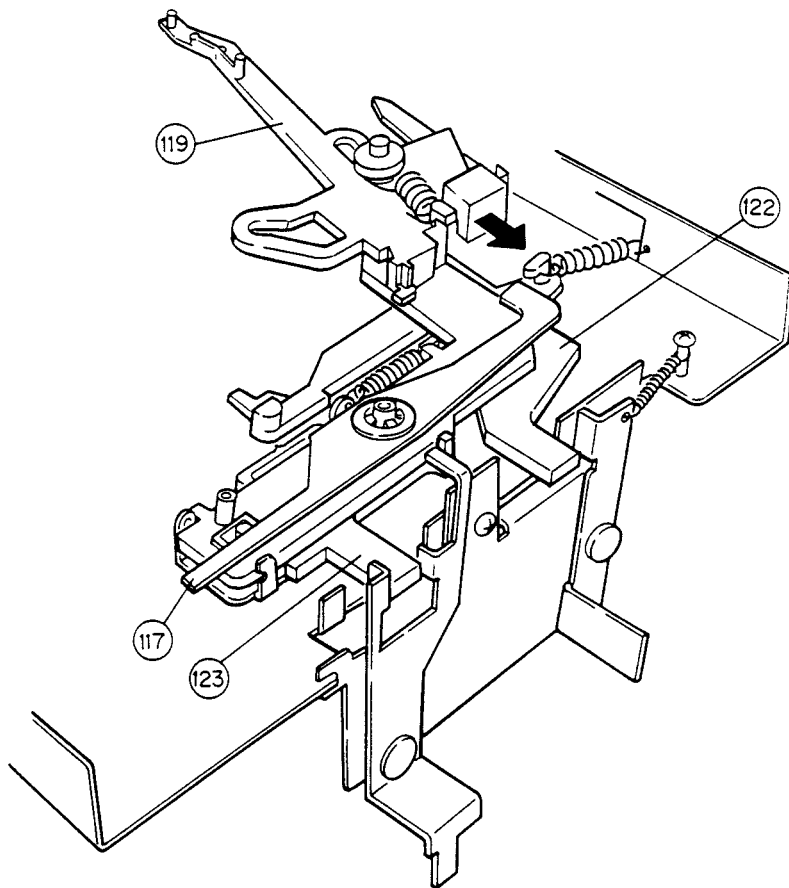

## 12. ADJUSTMENTS

### Tape speed adjustment

1. Connect the frequency counter to the TP1 terminal (Dolby TP: R-ch) on the complex assembly.
2. Turn the tape switch on.
3. Mount the test tape STD-301 onto deck I.
4. Short-circuit between terminals TP4 and TP5 on the tape assembly and put the deck I into play mode. (STD-301 is play backed in double speed.)
5. Adjust with VR803 so that the playback signal frequency of deck I becomes  $6020\text{Hz} \pm 10\text{Hz}$ .
6. Release the short-circuit between terminals TP4 and TP5.
7. Put the deck I into play mode and adjust with VR804 so that the playback signal frequency becomes  $3010\text{Hz} \pm 5\text{Hz}$ .  
(Note 1: Be sure not to turn VR803 while performing the normal speed adjustment.)
8. At this point, be sure to confirm that the wow and flutter are within 0.3% both in the double and normal speeds.
9. Mount the test tape STD-301 onto deck II.
10. Short-circuit between terminals TP4 and TP5 on the tape assembly and put the deck II into play mode. (STD-301 is play backed in double speed.)
11. Adjust with VR802 so that the playback signal frequency of deck II becomes  $\pm 20\text{Hz}$  against that of deck I.
12. Release the short-circuit between terminals TP4 and TP5.
13. Put the deck II into play mode and adjust with VR801 so that the playback signal frequency of deck II becomes  $\pm 10\text{Hz}$  against that of deck I.  
(Note: Be sure not to turn VR802 while performing the normal speed adjustment.)
14. At this point, be sure to confirm that the wow and flutter are within 0.3% both in the double and normal speeds.

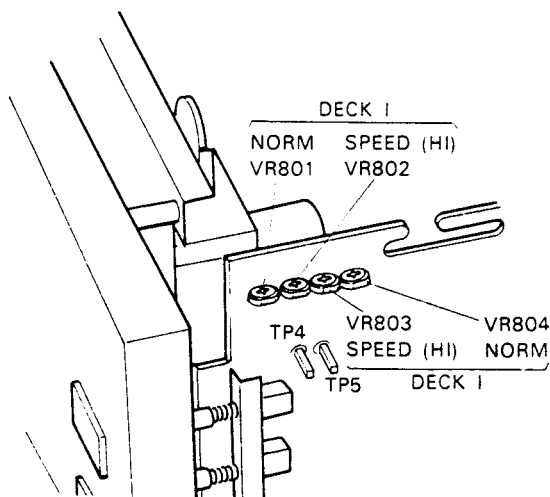

Fig. 12-1 Adjustment Point

## Electrical system adjustment

Prior to the electrical system adjustment, be sure to confirm the following items.

1. The mechanical adjustment should be completed.
2. Perform cleaning of the head and the demagnetization of head with the head eraser.
3. The level during measurement is determined at  $0\text{dBv} = 1\text{V}$ .
4. The specified tape should be used for adjustment. Since the test tape has A side and B side, use the A side with label.

STD-331B: For playback system adjustment

STD-608A: Normal blank tape

STD-620:  $\text{CrO}_2$  blank tape

STD-610: Metal blank tape

5. Prepare the following measuring instruments. AC millivoltmeter, low frequency oscillator, attenuator, and oscilloscope.
6. For the adjustment, perform both L and R channels unless otherwise specified.
7. Turn the Dolby NR switch to off unless otherwise specified.

8. Prior to the adjustment, be sure to perform aging of the set for several minutes. Especially prior to entering the adjustment of the recording and playback frequency characteristics, aging should be performed in REC/PLAY mode for 3 to 5 minutes.
9. The adjustment should be performed in accordance with the adjustment order. If the order is not kept, it may cause the failure of the complete adjustment which induces the inferior function of the unit.

### Deck I

1. Head azimuth adjustment
2. Playback level adjustment

### Deck II

1. Head azimuth adjustment
2. Playback level adjustment
3. Adjustment of recording and playback frequency characteristics
4. Adjustment of recording level

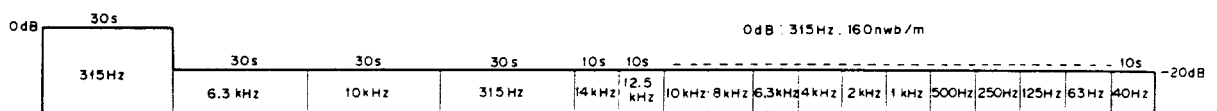

Fig. 12-2 Test tape STD-331B

Adjustment of Deck I *This deck is provided with an auto-tape-selector mechanism.							
<b>1. Head azimuth adjustment</b> * (Note) Do not select FWD and REV with the screwdriver being kept inserted.							
Procedure	Tape selector (AUTO)	Mode	Input signal/test tape	Adjusting point	Measuring point	Adjustment value	Remark
1	NORM	PLAY	Play back 10kHz/ -20dB on test tape STD-331B	Head azimuth adjusting screw (Fig. 12-3)	TP1 (R) TP2 (L)	Maximum playback signal level	After completion, lock the screw
<b>2. Playback level adjustment</b> * Perform this adjustment precisely since this adjustment is Dolby level setting during playback.							
Procedure	Tape selector (AUTO)	Mode	Input signal/test tape	Adjusting point	Measuring point	Adjustment value	Remark
1	NORM	PLAY	Play back 315Hz/0dB on test tape STD-331B	VR504 (R) VR503 (L)	TP1 (R) TP2 (L)	-13.5dBv ± 2dB	
Adjustment of Deck II *This deck is provided with an auto-tape-selector mechanism.							
<b>1. Head azimuth adjustment</b> * (Note) Do not select FWD and REV with the screwdriver being kept inserted.							
Procedure	Tape selector (AUTO)	Mode	Input signal/test tape	Adjusting point	Measuring point	Adjustment value	Remark
1	NORM	PLAY	Play back 315Hz/0dB on test tape STD-331B	Head azimuth adjusting screw (Fig. 12-3)	TP1 (R) TP2 (L)	Maximum playback signal level	After completion, lock the screw.
<b>2. Playback level adjustment</b> * Perform this adjustment precisely since this adjustment is Dolby level setting during playback.							
Procedure	Tape selector (AUTO)	Mode	Input signal/test tape	Adjusting point	Measuring point	Adjustment value	Remark
1	NORM	PLAY	Play back 315Hz/0dB on test tape STD-331B	VR502 (R) VR501 (L)	TP1 (R) TP2 (L)	-13.5 dBv ± 0.5 dB	
<b>3. Adjustment of recording and playback frequency characteristics</b> * This adjustment is performed in order to adjust the recording bias. Therefore, caution should be exercised not to worsen the distortion ratio due to under bias.							
Procedure	Tape selector (AUTO)	Mode	Input signal/test tape	Adjusting point	Measuring point	Adjustment value	Remark
1	NORM	REC	STD-608A and put into REC mode.	Bias oscillator frequency T701	Between (A) and (B) in Fig. 12-2	Confirm that the oscillation frequency 105 kHz ± 1 kHz.	When it is not within the standard, put it into the standard by adjusting T701.
2	NORM	REC	Apply the signal of 315Hz to the CD terminal and turn the CD switch on.	Input signal level	TP1 (R) TP2 (L)	-33.5 dBv ± 0.5 dB	
3	NORM	REC/PLAY	Record and play back 315Hz and 10kHz on test tape STD-608	VR702 (R) VR701 (L)	TP1 (R) TP2 (L)	Repeat recording and playback, and compensate so that the playback level of 10kHz against 315Hz becomes 0 ± 0.5dB.	
* Select the test tape, tape selector, and Dolby NR switch and satisfy the frequency characteristic zone as shown in Figs. 12-5 and 12-8.							
<b>4. Recording level adjustment</b> * Set the graphic equalizer and balance volume to the center and the mike mixing volume to the source side.							
Procedure	Tape selector (AUTO)	Mode	Input signal/test tape	Adjusting point	Measuring point	Adjustment value	Remark
1	NORM	REC	Apply the signal of 315Hz to the CD terminal and turn the CD switch on.	Input signal level	TP1 (R) TP2 (L)	-33.5 dBv (± 0.5 dB)	
2	NORM	REC/PLAY	Record and play back 315Hz to the test tape STD-608A.	VR704 (R) VR703 (L)	TP1 (R) TP2 (L)	Repeat recording and playback, and compensate so that the playback level of 315Hz becomes -13.5 dBv (± 0.5 dB).	
3	CrO <sub>2</sub>	REC/PLAY	Record and play back 315Hz to the test tape STD-620.		TP1 (R) TP2 (L)	Confirm that the playback level of 315Hz becomes -13.5 dBv (± 1.0 dB).	
4	METAL	REC/PLAY	Record and play back 315Hz to the test tape STD-610.		TP1 (R) TP2 (L)	Confirm that the playback level of 315 Hz becomes -13.5 dBv (± 1.0 dB).	

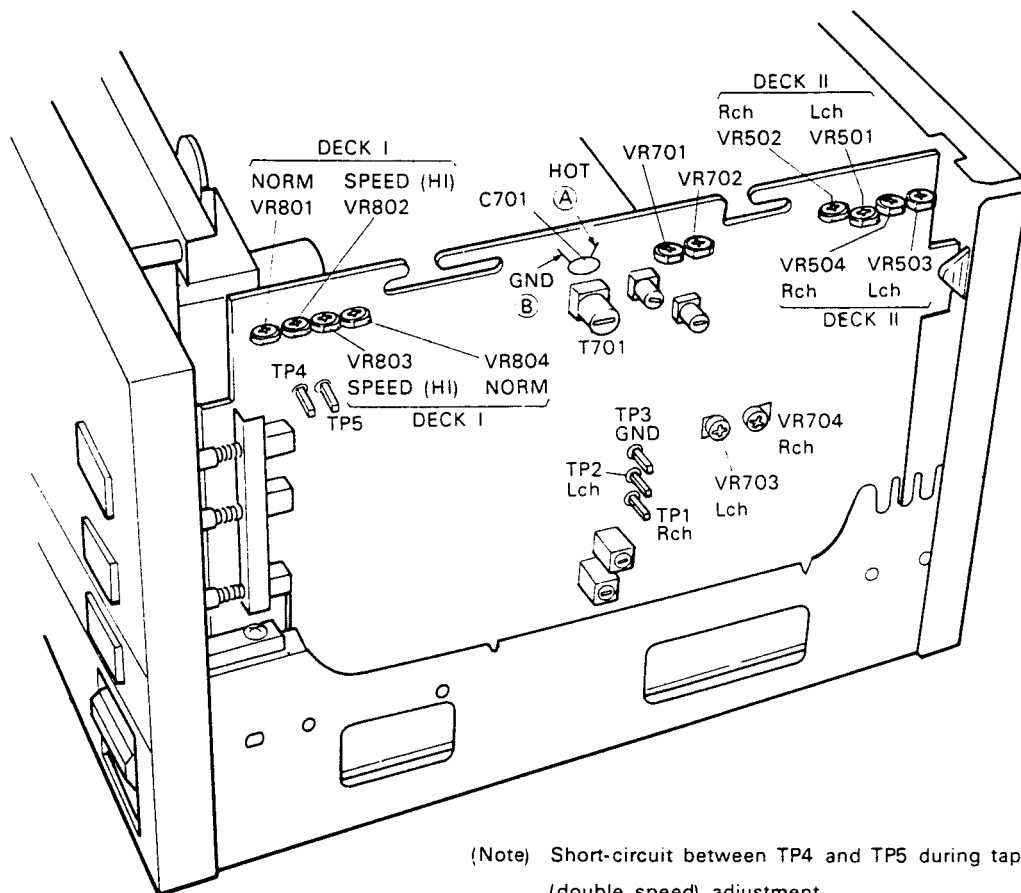

Fig. 12-3 Arrangement diagram of adjusting parts

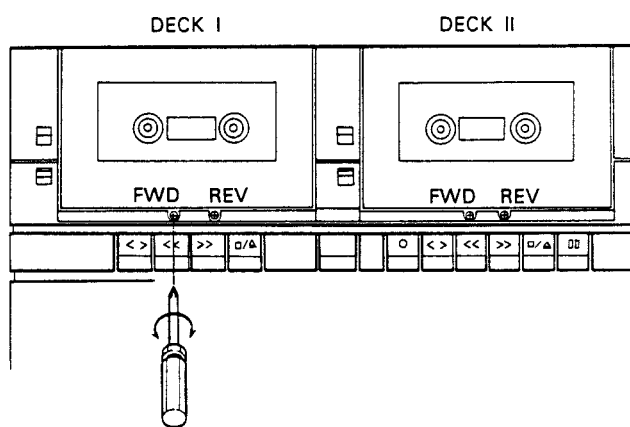

Fig. 12-4 Head azimuth adjustment

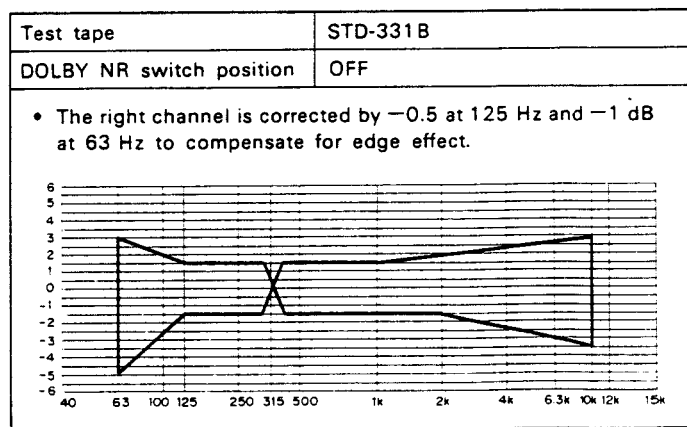

Fig. 12-5 Playback frequency response tolerance zone

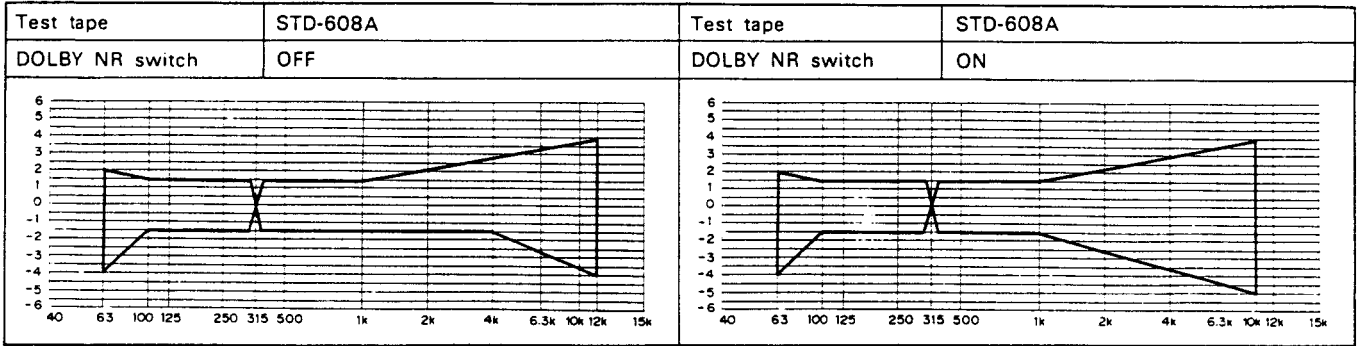

Fig. 12-6 Recording & playback frequency response tolerance zone (NORM)

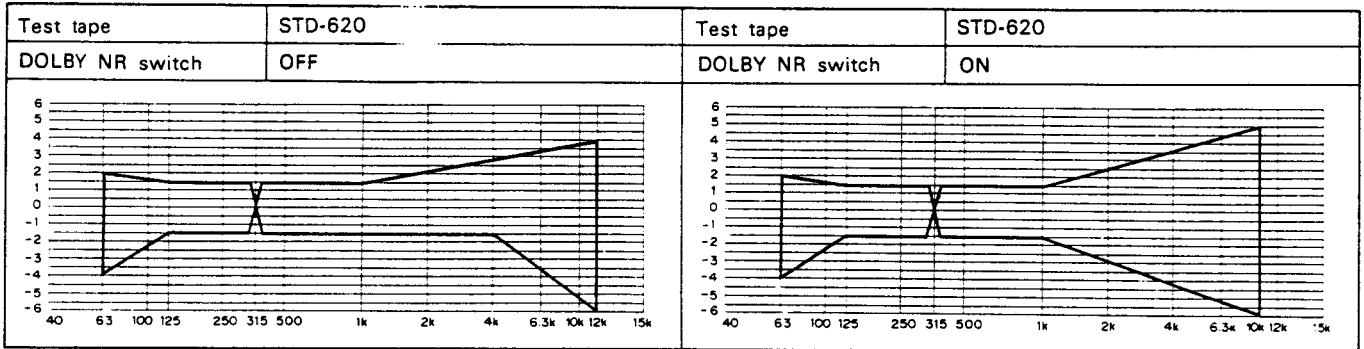

Fig. 12-7 Recording & playback frequency response tolerance zone (CrO2)

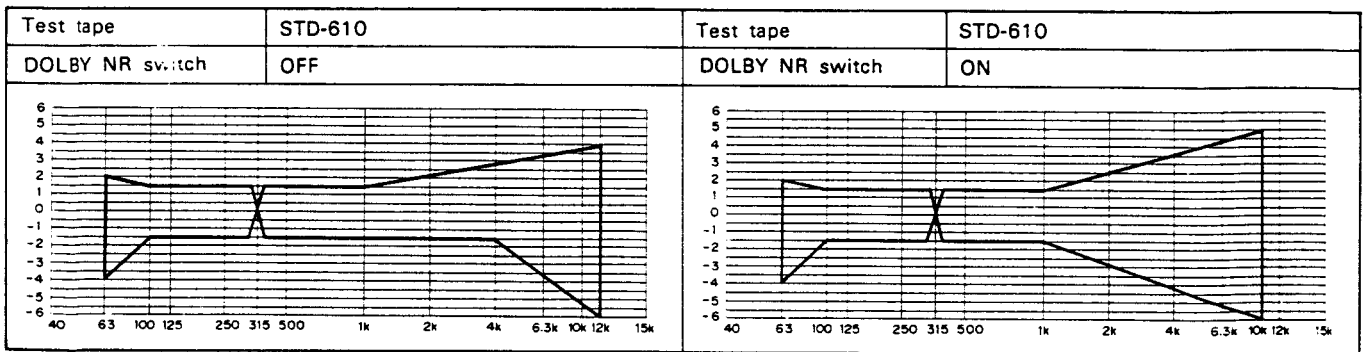

Fig. 12-8 Recording & playback frequency response tolerance zone (METAL)

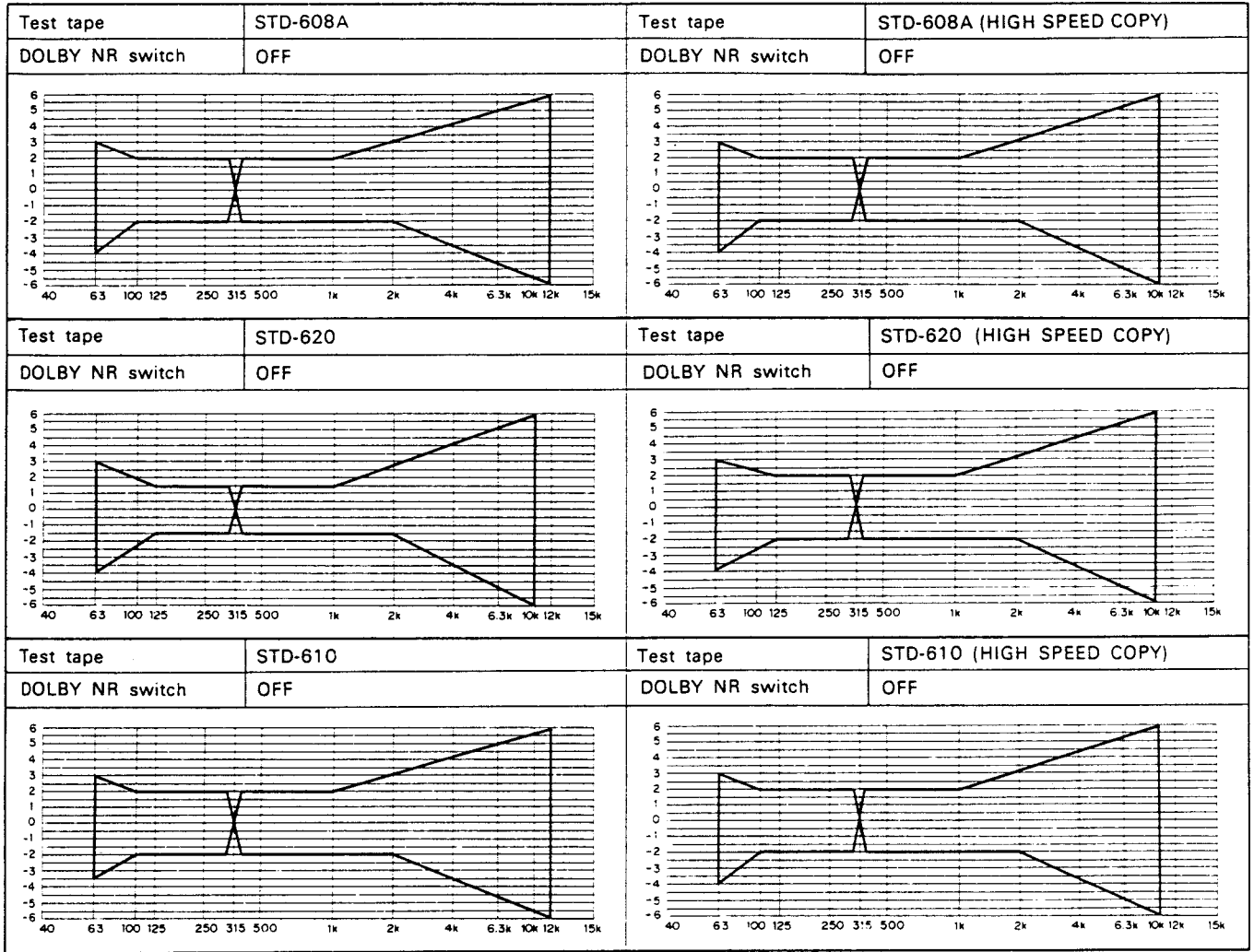

Fig. 12-9 Copy mode recording & playback frequency response (for reference purposes)



## 13. DISASSEMBLY

### 13-1. REMOVAL OF CASSETTE MECHANICAL UNIT

1. Remove 6 screws ❶.
2. Remove the bonnet case.
3. Remove 2 screws ❷.
4. Press the claw of the chassis bottom and remove the front panel (to which the cassette mechanical unit is attached) and pull out toward you.
5. Remove 4 tape assembly connectors (J9, J10, J11 and J12) and 2 parallel jumpers (J901 and J902) from the wiring connectors which are extended from the cassette mechanical unit.

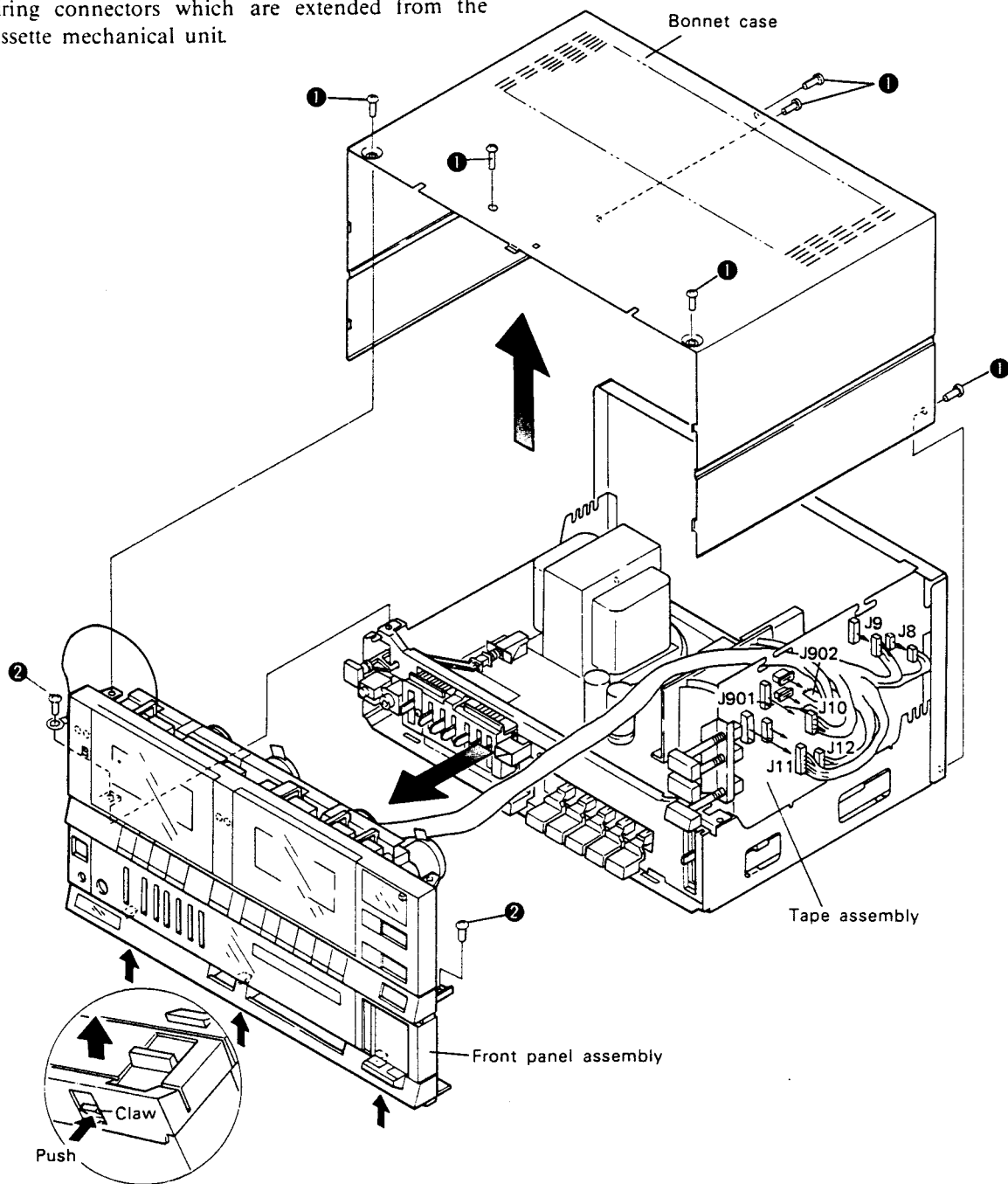

Fig. 13-1 Removal of the front panel assembly

6. Since J8 has been soldered from the rear side, remove the shield wire (the head shield wire of the mechanism I) by using a soldering iron and cut the binders B11 and B12 with a nipper, and then remove the front panel (to which the cassette mechanical unit is attached) from the main body.
7. Remove the counter belt from the counter and apply it to the cassette mechanical unit.
8. Remove 6 screws ③ and remove the cassette mechanical unit from the front panel.

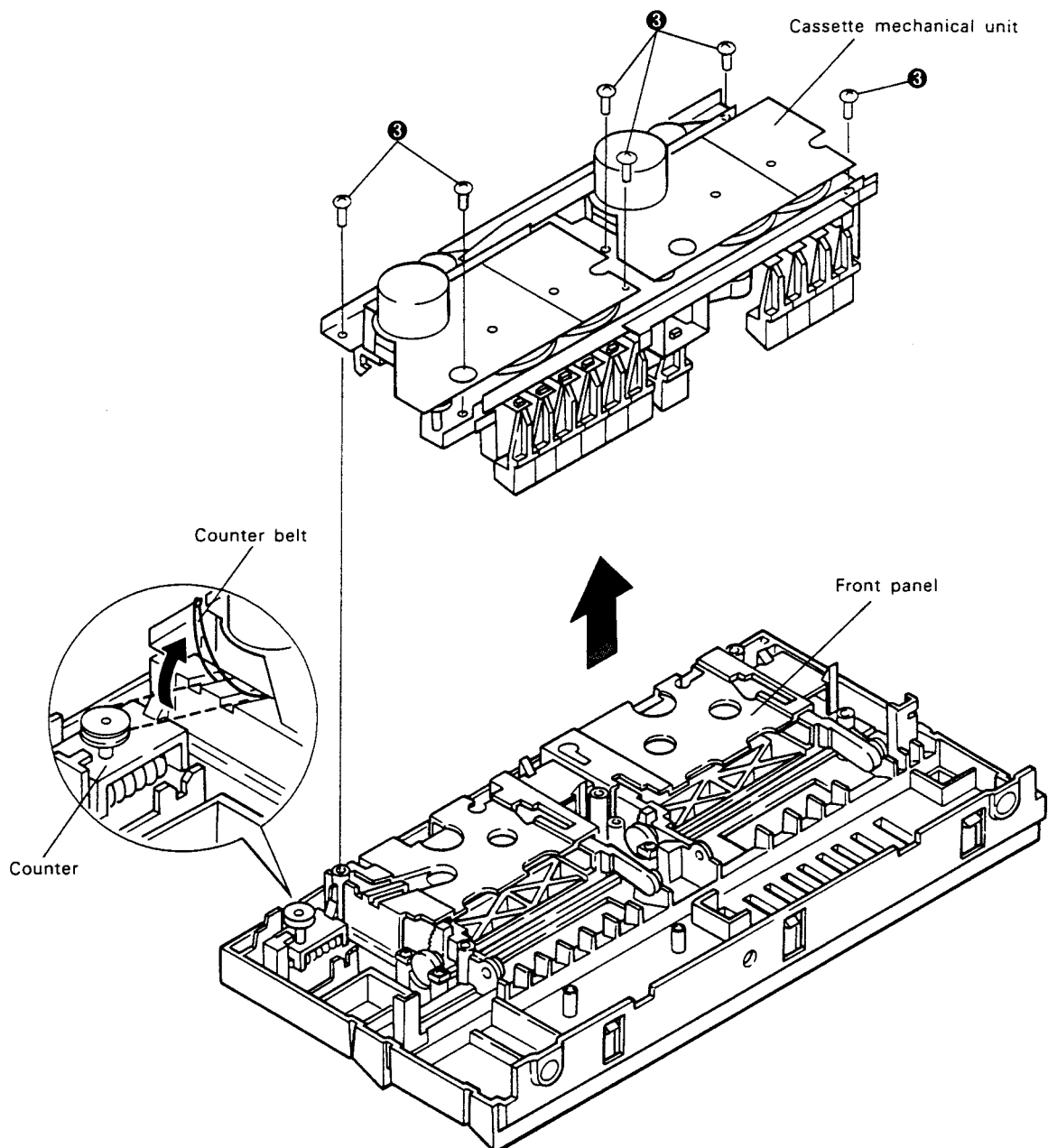

Fig. 13-2 Appliance of belt

**13-2. REMOVAL OF BELT**

1. Remove the cassette mechanical unit from the main body.  
(See Removal of mechanical unit)
2. Cut the binder which bundles the head lead wires.
3. Remove 4 screws ❶ and remove the FW receiving plate from the mechanical chassis.
4. Remove the belt.

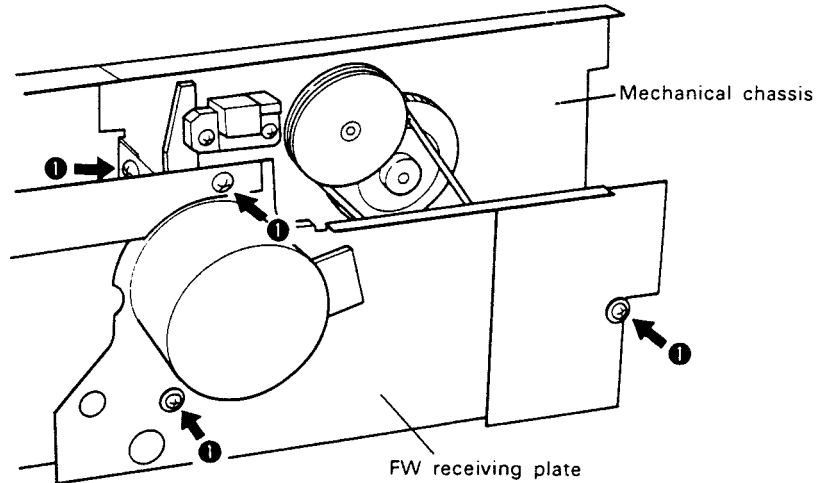

Fig. 13-3 Removal of belt

**13-3. APPLIANCE OF BELT**

1. Apply the flat belt as shown in the broken lines through ㉞ section (belt temporary holding shaft) in the Fig13-4.
2. Apply the square belt as shown ㉟ in Fig13-4.
3. Install the FW receiving plate to the mechanical chassis and transfer the flat belt, which has been held temporary at ㉞ section, to the motor pulley.

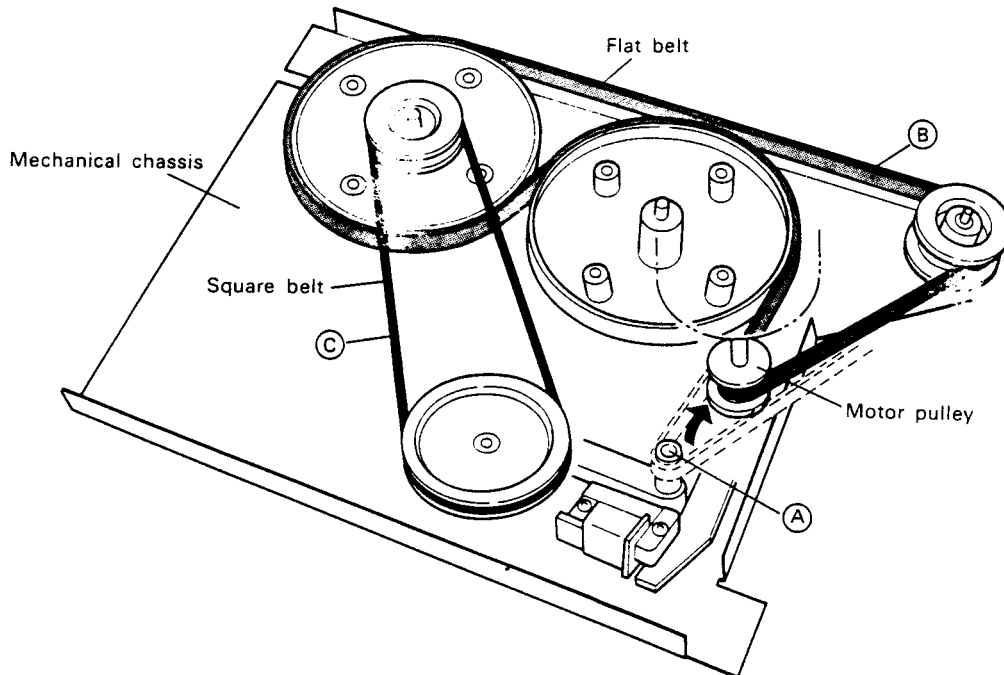

Fig. 13-4 Appliance of belt

**13-4. REMOVAL OF MOTOR**

1. Remove the mechanical unit from the main body. (See Removal of mechanical unit)
2. Remove the lead wires of the motor from motor. (See Fig13-5)
3. Remove the FW receiving plate. (See Removal of belt)
4. Remove 2 screws ❶ and remove the motor. (See Fig13-6)

Note 1: Care should be taken to the motor installation direction and attaching position of the motor lead wires when the motor is replaced.

Note 2: Perform the tape speed adjustment (See Fig13-6) when the motor is replaced.

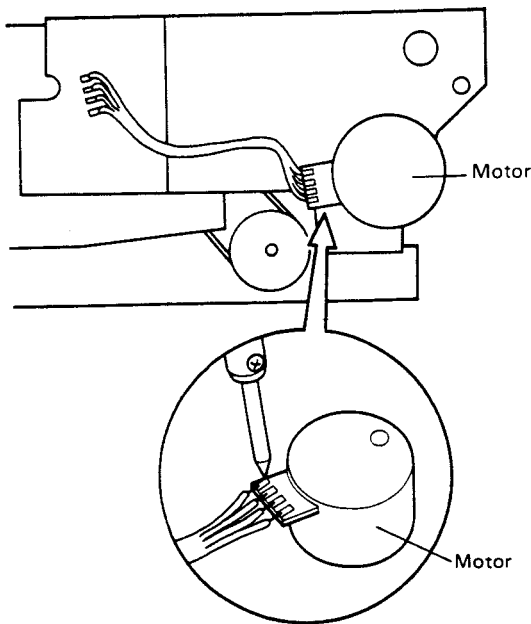

Fig. 13-5 Removal of motor lead wires

**13-5. REPLACEMENT OF HEAD**

1. Remove the mechanical unit from the main body. (See Removal of mechanical unit)
2. Remove 2 screws ❶ for head installation and pull out the head assembly. (See Fig13-7)
3. Remove the lead wires from the head section board by using a soldering iron.
4. Solder the new lead wires to the new head. (See Fig13-7)

Note 1: At this point, be sure to make the soldering of the lead wires to their respective positions without fail.

Note 2: Be sure to perform the mechanical adjustment and electrical adjustment when the head is replaced.

Note 3: When replacing the head, be sure lock the screws which have been used for the head installation.

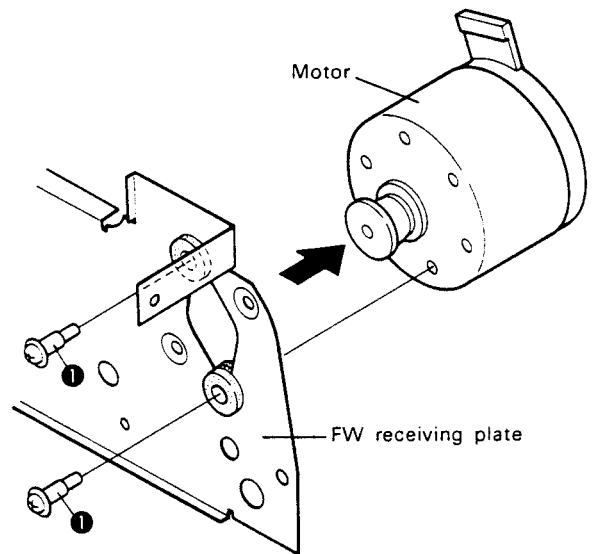

Fig. 13-6 Removal of motor

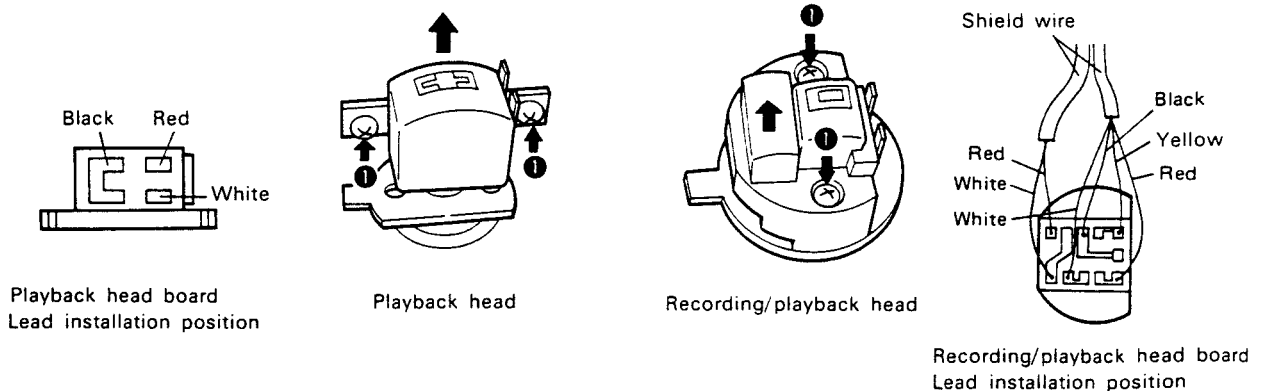

Fig. 13-7 Removal of head assembly