

Service Manual

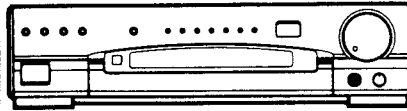

ORDER NO.
ARP2402

TUNER CONTROL AMPLIFIER

CX - J500

CX - J500 HAS THE FOLLOWING :

| Type | Power Requirement | Remarks |
|-------|----------------------------------------------------|---------|
| HE | AC 220 V - 230 V, 240 V (switchable)* | |
| HEWZI | AC 220 V - 230 V, 240 V (switchable)* | |
| HB | AC 220 V - 230 V, 240 V (switchable)* | |
| SD | AC 110 V, 120 V - 127 V, 220 V, 240 V (switchable) | |

* Change the connection of the power transformer's primary wiring.

- This manual is applicable to HE, HB and SD types.
- As to HB and SD types, refer to page 35.
- As to the other type(s), refer to applicable service manual(s).
- These products are systems components. Each of these products does not function properly when independent; to avoid malfunctions, be sure to connect it to the prescribed system component(s), otherwise damage may result.
- These products' instructions are contained within the operating instructions manual of the related system component(s).
- The manual is packed with those component(s). These products' accessories etc. are packed with their related component(s).
- Ce manuel pour le service comprend les explications de réglage en français.
- Este manual de servicio trata del método ajuste escrito en español.

CONTENTS

| | | | |
|-------------------------------------------------------------|----|------------------------------|----|
| 1. EXPLODED VIEWS AND PARTS LIST | 2 | 6. ADJUSTMENTS | 29 |
| 2. PCB PARTS LIST | 5 | 6. REGLAGE | 30 |
| 3. PANEL FACILITIES | 8 | 6. AJUSTE | 31 |
| 4. SPECIFICATIONS | 10 | 7. FOR HB AND SD TYPES | 35 |
| 5. SCHEMATIC DIAGRAMS AND PCB CONNECTIONS DIAGRAMS | 11 | | |

1. EXPLODED VIEWS AND PARTS LIST

NOTES:

- The parts with an encircled number are generally unavailable because they are not in our Master Spare Parts List.
- The Δ mark found on some component parts indicates the importance of the safety factor of the part. Therefore, when replacing, be sure to use parts of identical designation.
- Parts marked by "●" are not always kept in stock. Their delivery time may be longer than usual or they may be unavailable.

| Mark | No. | Description | Parts No. | Mark | No. | Description | Parts No. |
|----------|-----|-------------------|-----------|----------|-----|------------------------------|--------------|
| | 1 | VOL KNOB | AAB1259 | | 31 | CHASSIS | ANA1160 |
| | 2 | KNOB (SMALL) | AAB1270 | | 32 | REAR PANEL | ANC1809 |
| | 3 | BAND BUTTON | AAD2100 | | 33 | METAL BONNET | ANE1323 |
| | 4 | FUNCTION BUTTON | AAD2102 | | 34 | BRACKET(JACK) | ANG1488 |
| | 5 | POWER BUTTON | AAD2104 | | 35 | MAGNET PLATE | ANG1558 |
| | 6 | TIMER BUTTON | AAD2105 | Δ | 36 | POWER TRANSFORMER (T1) | ATT1178 |
| | 7 | INTERNAL PANEL | AAK2221 | | 37 | TUNER ASSEMBLY | AWE1230 |
| | 8 | INDICATOR LENS | AAK2222 | Δ | 38 | FUSE (FU3 T1A/250V)(SD only) | AEK-508 |
| | 9 | PANEL | AAK2223 | | 39 | DUMPER ASSY | AXA1013 |
| | 10 | SCREW | ABA-298 | | 40 | MAGNET | AXX1016 |
| | 11 | SCREW (STEEL) | ABA1009 | | 41 | SCREW | BBZ26P080FMC |
| | 12 | SCREW (STEEL) | ABA1011 | | 42 | NUT | NK90FUC |
| | 13 | SCREW | ABA1018 | | 43 | FOOT ASSY(ABS) | RXA1448 |
| | 14 | SCREW (STEEL) | ABA1143 | Δ | 44 | FUSE(FU1 T2.5A) | AEK-512 |
| Δ | 15 | AC POWER CORD | ADG1019 | Δ | 45 | FUSE(FU2 T1A) | AEK-508 |
| | 16 | FFC | ADD1102 | Δ | 46 | FUSE(FU4 T5A) | AEK-515 |
| | 17 | BINDER | AEC-826 | Δ | 47 | FUSE(FU5 T5A) | AEK-515 |
| Δ | 18 | STRAIN RELIEF | AEC-882 | Δ | 48 | FUSE(FU6 T1.6A) | AEK-510 |
| | 19 | PCB SUPPORT | AEC1010 | Δ | 49 | FUSE(FU7 T1.6A) | AEK-510 |
| | 20 | PCB SPACER | AEC1100 | Δ | 50 | FUSE(FU8 T2A) | AEK-511 |
| | 21 | NYLON RIVET | AEC1160 | ● | 51 | AF ASSEMBLY | AWZ3765 |
| | 22 | SPACER | AEC1236 | ● | 52 | DISPLAY ASSEMBLY | AWZ3769 |
| | 23 | BINDER | AEP-215 | ● | 53 | VR ASSEMBLY | AWZ3771 |
| | 24 | TERMINAL SCREW | AKE-031 | ● | 54 | MIC ASSEMBLY | AWZ3774 |
| Δ | 25 | AC SOCKET 1-P | AKP-508 | ● | 55 | FUSE ASSEMBLY | AWZ3975 |
| Δ | 26 | FUSE HOLDER | AKR-038 | | 56 | SHIELD ASSY | AWZ4117 |
| | 27 | FRONT PANEL | AMB1915 | | | | |
| | 28 | PCB MOLD | AMR1525 | | | | |
| | 29 | LEG ASSY(S) | AMR1937 | | | | |
| | 30 | SEALING DOOR ASSY | AMR2338 | | | | |

EXPLODED VIEW

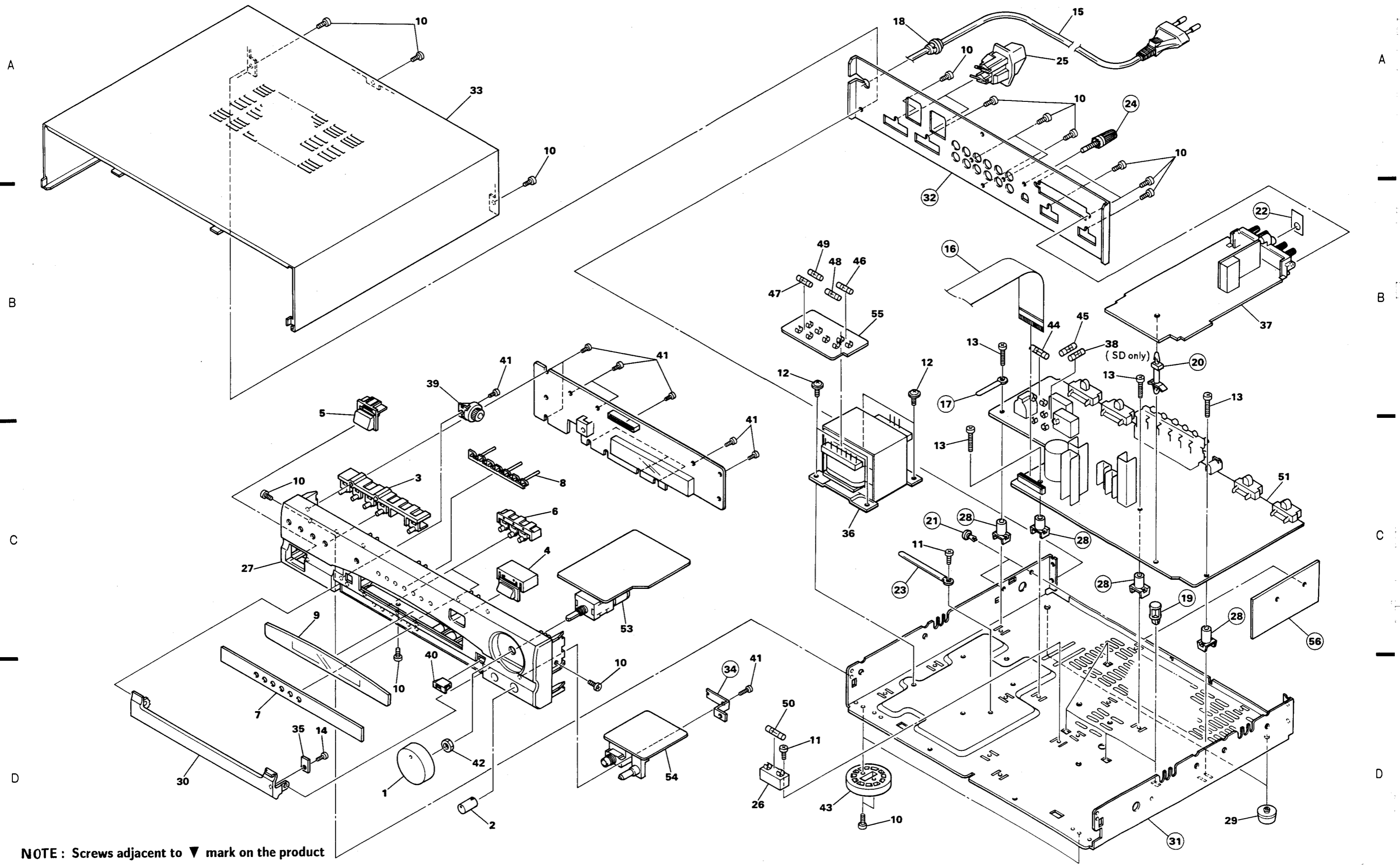

NOTE : Screws adjacent to ▼ mark on the product are used for disassembly.

| Mark | No. | Description | Parts No. |
|------|----------|----------------------|--------------|
| | C225,226 | ELECTR.CAPACITOR | CEAS470M10 |
| | C231,232 | CERAMIC CAPACITOR | CKPUYB101K50 |
| | C235,236 | CERAMIC CAPACITOR | CKDYB562K50 |
| | C237,238 | CERAMIC CAPACITOR | CKCYB152K50 |
| | C239 | ELECTR.CAPACITOR | CEAS3R3M50 |
| | C240 | ELECTROLYTIC CAPACIT | CEAS3R3M50 |
| | C241,242 | ELECTR.CAPACITOR | CEAS470M10 |
| | C243,244 | ELECTR.CAPACITOR | CEAS100M25 |
| | C249,250 | ELECTR.CAPACITOR | CEAS100M25 |
| | C257 | CERAMIC CAPACITOR | CKCYX103M25 |
| | C301 | CERAMIC CAPACITOR | CKCYX473M25 |
| | C302 | CERAMIC CAPACITOR | CKCYF473Z50 |
| | C303 | ELECTR.CAPACITOR | CEAS470M16 |
| | C304 | CERAMIC CAPACITOR | CKCYX473M25 |
| | C305 | ELECTR.CAPACITOR | CEAS010M50 |
| | C306,307 | CERAMIC CAPACITOR | CKCYB102K50 |

RESISTORS

| | | |
|-----------------|--------------------------------|--------------|
| R102 | METAL OXIDE RESISTOR | RS1LMF102J |
| R104 | METAL OXIDE RESISTOR | RS1LMF102J |
| R106 | METAL OXIDE RESISTOR | RS1LMF562J |
| R107 | FUSLIBLE RESISTOR | RFA1/4PL4R7J |
| R116 | METAL OXIDE RESISTOR | RS3LMF151J |
| R117 | METAL OXIDE RESISTOR | RS3LMF181J |
| R119,120 | CARBON FILM RESISTOR | RD1/4PMF470J |
| R121-124 | CARBON FILM RESISTOR | RD1/4PM100J |
| R127 | METAL OXIDE RESISTOR | RS1LMF180J |
| R245,246 | CARBON FILM RESISTOR | RD1/4PM820J |
| R305 | RESISTOR ARRAY (56k Ω) | RA5T563J |
| R312 | RESISTOR ARRAY (56k Ω) | RA5T563J |
| R345 | RESISTOR ARRAY (56k Ω) | RA5T563J |
| Other Resistors | | RD1/8PM□□□J |

OTHERS

| | | |
|--------------|----------------------|--------------|
| X301 | CERAMIC RESO. (4MHz) | ASS1025 |
| CN2 | CONNECTOR(15P) | KPE15 |
| CN3 | CONNECTOR(13P) | KPE13 |
| CN5 | SOCKET(27P) | AKP1099 |
| CN6 | SOCKET(10P) | AKP1073 |
| CN7 | SOCKET(9P) | AKP1072 |
| CN21 | CONNECTOR(4P) | KPE4 |
| JACK | | AKN-203 |
| PIN JACK(6P) | | AKB1121 |
| PIN JACK(6P) | | AKB1129 |
| SCREW | | BBZ30P080FZK |
| SOCKET(15P) | | AKP1049 |

● DISPLAY ASSEMBLY(AWZ3769)

SEMICONDUCTORS

| | | |
|----------|-------------|-----------|
| IC701 | LOGIC IC | SN74LS42N |
| IC702 | CONTROL MCU | PDG075A |
| Q701 | TRANSISTOR | XDC143ES |
| Q702 | TRANSISTOR | 2SC2458 |
| D701 | DIODE | 1SS252 |
| D702-708 | LED(RED) | AEL1108 |
| D709-711 | DIODE | 1SS252 |
| D712 | ZENER DIODE | RD6.2ESB |
| D713-721 | DIODE | 1SS252 |

| Mark | No. | Description | Parts No. |
|-----------------|----------|---------------------------------------------------------------------------------------------------------------------------------------------------------------|-----------|
| SWITCHES | | | |
| | S701-716 | SWITCH | ASG1034 |
| | | SURROUND MODE, FUNC, STATION MEMORY, LOCAL/DX, SET, WAKE UP, REC, CLOCK ADJ, AUDITION, CENTER MODE, DELAY TIME, POWER, BAND, FREQ/ST, DOWN, UP | |

FILTER

| | | |
|------|----------------|---------|
| L701 | AXIAL INDUCTOR | LAU220K |
|------|----------------|---------|

CAPACITORS

| | | |
|------|----------------------|--------------|
| C702 | ELECTROLYTIC CAPACIT | CEJA4R7M35 |
| C703 | CERAMIC CAPACITOR | CKCYF223Z50 |
| C704 | CERAMIC CAPACITOR | CKPUYF473Z16 |
| C705 | ELECTR.CAPACITOR | CEJA010M50 |
| C706 | ELECTR.CAPACITOR | CEAS2R2M50 |
| C707 | CERAMIC CAPACITOR | CKCYB102K50 |
| C708 | ELECTR.CAPACITOR | CEJA470M10 |
| C709 | CERAMIC CAPACITOR | CKCYX473M25 |
| C710 | CEA (47000/5.5V) | ACH1037 |
| C711 | ELECTR.CAPACITOR | CEJA470M10 |
| C712 | ELECTR.CAPACITOR | CEAS4R7M50 |
| C713 | CERAMIC CAPACITOR | CKPUYF473Z16 |
| C715 | ELECTR.CAPACITOR | CEAS471M10 |
| C716 | CERAMIC CAPACITOR | CKDYB472K50 |

RESISTORS

| | | |
|-----------------|--------------------------------|-------------|
| R734 | RESISTOR ARRAY (47k Ω) | RA8S473J |
| R745 | RESISTOR ARRAY (47k Ω) | RA8S473J |
| R746 | RESISTOR ARRAY (47k Ω) | RA11S473J |
| Other Resistors | | RD1/8PM□□□J |

OTHERS

| | | |
|----------------------|-------------------------|---------|
| V701 | FL TUBE | AAV1138 |
| X702 | CRYSTAL RESO. (8.00MHz) | ASS1015 |
| CN4 | SOCKET(27P) | AKP1099 |
| REMOTE RECEIVER UNIT | | AXX1010 |

● VOLUME ASSEMBLY(AWZ3771)

SEMICONDUCTORS

| | | |
|------------|---------------------|----------|
| IC1601 | MECHANISM DRIVER IC | TA7291S |
| IC1602 | IC | UPC4570C |
| Q1601,1602 | TRANSISTOR | 2SC2878 |
| Q1605 | TRANSISTOR | RN2203 |

FILTER

| | | |
|-------|----------------|---------|
| L1601 | AXIAL INDUCTOR | LAU221K |
|-------|----------------|---------|

CAPACITORS

| | | |
|------------|-------------------|-------------|
| C1601-1604 | ELECTR.CAPACITOR | CEAS2R2M50 |
| C1605,1606 | ELECTR.CAPACITOR | CEAS100M25 |
| C1607,1608 | ELECTR.CAPACITOR | CEAS101M16 |
| C1609,1610 | CERAMIC CAPACITOR | CKCYX104M25 |
| C1627 | CERAMIC CAPACITOR | CKCYX473M25 |
| C1629,1630 | CERAMIC CAPACITOR | CKCYB331K50 |
| C1631 | ELECTR.CAPACITOR | CEAS101M16 |

| Mark No. | Description | Parts No. | Mark No. | Description | Parts No. |
|-------------------------------|----------------------|-------------|------------------------------------|------------------|------------|
| RESISTORS | | | C407,408 | ELECTR.CAPACITOR | CEAS470M25 |
| VR1601 | VARIABLE RESISTOR | ACX1064 | RESISTORS | | |
| R1613 | CARBON FILM RESISTOR | RD1/4PM121J | VR401 | VARIABLE(10K-X1) | ACS1025 |
| R1614 | CARBON FILM RESISTOR | RD1/4PM121J | Other Resistors | | |
| Other Resistors | | | RD1/8PM | | RD1/8PM |
| ●MIC ASSEMBLY(AWZ3774) | | | OTHERS | | |
| SEMICONDUCTOR | | | JACK | | AKN1017 |
| IC401 | OP-AMP IC | RC4558DXP | ●FUSE ASSEMBLY(AWZ3975) | | |
| CAPACITORS | | | FUSE assembly has no service part. | | |
| C401 | CERAMIC CAPACITOR | CKCYB332K50 | | | |
| C402 | ELECTROLYTIC CAPACIT | CEJA100M25 | | | |
| C403 | CERAMIC CAPACITOR | CKCYB331K50 | | | |
| C404,405 | ELECTR.CAPACITOR | CEAS010M50 | | | |
| C406 | ELECTROLYTIC CAPACIT | CEJA100M25 | | | |

3. PANEL FACILITIES

REAR PANEL FACILITIES

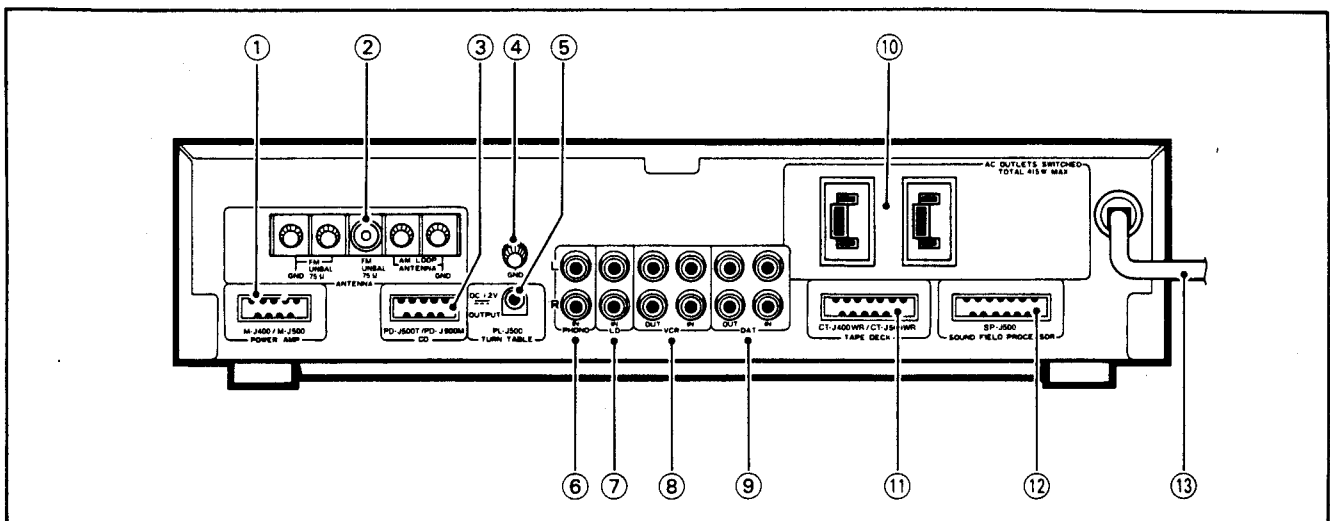

- ① **POWER AMP jack**
Connect the power amplifier (M-J400/M-J500) cable here.
- ② **FM/AM ANTENNA terminals**
Antennas must be connected to these terminals: otherwise you will not be able to receive stations. See page 11 for details on ANTENNA CONNECTIONS.
- ③ **CD jack**
Connect the compact disc player (PD-J500T/PD-J900M) cable here.
- ④ **Ground terminal (GND)**
Connect the ground lead of the turntable here (except for PL-J500).
- ⑤ **TURNTABLE (DC 12 V OUTPUT) jack**
This jack supplies power to the turntable PL-J500.
- ⑥ **PHONO input jacks**
Connect the output cord of the turntable to these jacks.
- ⑦ **LD input jacks**
Connect to the output jacks of the LD player.
- ⑧ **VCR jacks**
IN : Connect to the output jacks of VCR.
OUT : Connect to the input jacks of VCR.
- ⑨ **DAT jacks**
IN : Connect to the analog audio output jacks of the digital audio tape deck.
OUT : Connect to the analog audio input jacks of the digital audio tape deck.
- ⑩ **AC OUTLETS (SWITCHED TOTAL 415 W MAX)**
Power supplied through this outlet is turned on and off by the tuner control amplifier's POWER switch. Total electrical power consumption of connected equipment should not exceed 415 W. PD-J500T or PD-J900M CD player power cords, and the M-J400/M-J500 power amplifier cords can be connected.

NOTE:

Do not connect appliances with high power consumption such as heaters, irons, or television sets to the AC OUTLET in order to avoid overheating or fire risk. This can cause the amplifier to malfunction.

CAUTION:
DO NOT CONNECT TV SET OR MONITOR.

⑪ TAPE DECK jack

Connect the cassette deck (CT-J400WR/CT-J500WR) cable here.

⑫ SOUND FIELD PROCESSOR jack

Connect the sound field processor (SP-J500) cable here.

⑬ Power cord

Connect this to the AC wall socket.

FRONT PANEL FACILITIES

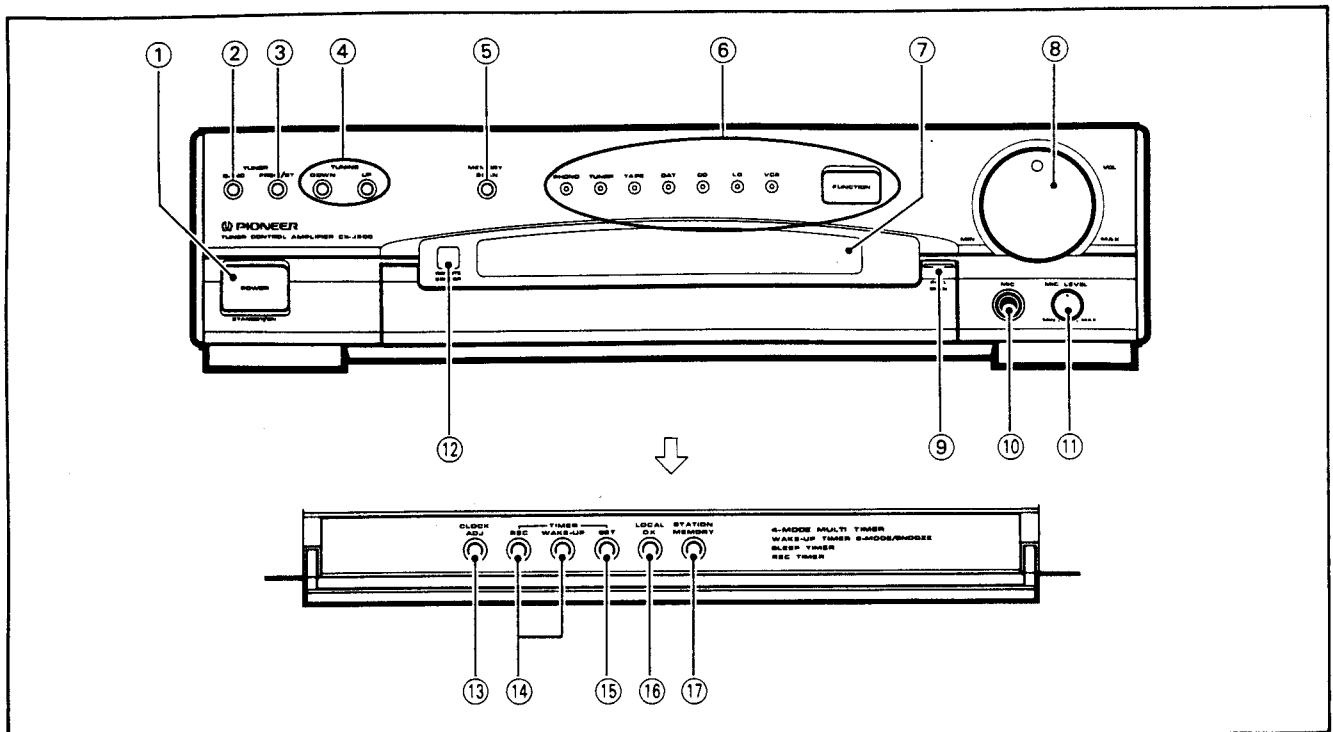

① POWER STANDBY/ON switch

This is the switch for electric power.

ON When set to the ON position, power is supplied and the unit becomes operational.

STANDBY .. When set to the STANDBY position, the main power flow is cut and the unit is no longer fully operational. A minute flow of power feeds the unit to maintain operation readiness.

When only the time is indicated in the display section, the unit is in STANDBY.

② BAND selector button

Each time this button is pressed, FM, MW or LW (except for the multi-voltage model) reception is selected in order.

③ FREQ/ST (Frequency/Station) button

Use to switch between the Frequency mode and the Station Call mode.

④ TUNING (UP, DOWN) buttons

[During tuning]

- When in the Frequency mode, use to raise and lower the reception frequency.
- When in the Station mode, use to raise and lower the station number.

[During time and timer setting]

Used for adjusting the clock, timer settings and its related adjustments.

⑤ MEMORY SCAN button

Press this button to scan programs on the preset stations automatically for 7 seconds each. If you wish to continue listening to the station currently being scanned, press this button again to lock the tuning to the station. This will cancel the preset scan function and return you to normal reception.

⑥ FUNCTION button/indicators

Each time you press the FUNCTION button, the amplifier function changes. The selected function's indicator lights.

[PHONO]

Select to play records on a turntable connected to the PHONO input jacks.

[TUNER]

Select to listen to radio broadcast.

[TAPE]

Select to listen to cassette tape.

[DAT]

Select to listen a DAT playing on a digital audio tape deck connected to the DAT jacks.

[CD]

Select to listen to compact disc.

[LD]

Select to play an LD on a video disc player connected to the LD input jacks.

[VCR]

Select to play a tape on a video cassette recorder connected to the VCR jacks.

⑦ Display section

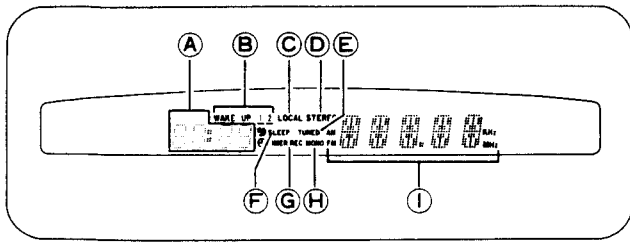

- A Time/channel indicator**
Normally indicates the current time. The current time is shown when the display is in the frequency mode; the channel number is shown when the display is in the station mode.
- B WAKE UP timer indicator**
Displays the selected wake up timer.
- C LOCAL indicator**
Lights when the LOCAL/DX button ⑮ is set to ON.
- D STEREO indicator**
Lights when an FM stereo broadcast is received (FM MONO button on the remote control unit set to OFF).
- E TUNED indicator**
Lights when a broadcast is received and tuned in well.
- F SLEEP indicator**
Indicates that the sleep timer is activated.
- G REC timer indicator**
Displays the timer's setting condition.
- H MONO indicator**
Lights when the FM MONO button on the remote control unit is set to ON. When this indicator is lit, FM stereo broadcasts are reproduced monaurally.
- I Frequency display**
Shows received broadcast frequency. Also gives scrolling display of main function status.
FM and MHz light: FM reception.
AM and kHz light: MW or LW (except for the multi-voltage model) reception.

- ⑧ VOL (VOLUME) control**
- ⑨ Open the hinged panel door with your finger.**
- ⑩ MIC (microphone) jack**
This is a standard jack for connecting a microphone.
- ⑪ MIC LEVEL control**
Used for adjusting the volume of microphone.
- ⑫ REMOTE SENSOR**
- ⑬ CLOCK ADJ button**
Used for starting the clock adjustment.
- ⑭ Timer selector buttons**
[WAKE-UP 1, 2]
Used for timer playback setting.
[REC]
Used for timer recording setting.
- ⑮ SET button**
Used for current time, timer playback, and timer recording setting.
- ⑯ LOCAL/DX button (when receiving FM broadcasts)**
Use this if the broadcast signal is too strong, causing noise and distortion. The attenuator reduces the strength of the signal, reducing noise and distortion.
- ⑰ STATION MEMORY button**
Used to memorizing stations.

4. SPECIFICATIONS

FM Tuner Section

| | |
|-------------------------------------------------|-----------------------------------|
| Frequency range | 87.5 MHz to 108 MHz |
| Usable Sensitivity | Mono: 12.8 dBf, IHF (1.2 μV/75 Ω) |
| Sensitivity (DIN) | Mono S/N 26 dB: 1 μV/75 Ω |
| | Stereo S/N 46 dB: 50 μV/75 Ω |
| Signal-to-Noise Ratio (IHF, 85 dBf Input) | Mono: 77 dB |
| Signal-to-Noise Ratio (DIN) | Mono: 66 dB |
| | Stereo: 60 dB |
| Distortion | Stereo: 0.5% (1 kHz) |
| Antenna Input | 75 Ω unbalanced |

MW (AM) Tuner Section

| | |
|---------------------------------------|----------------------|
| Frequency range | |
| 9 kHz step | 531 kHz to 1,602 kHz |
| 10 kHz step | 530 kHz to 1,700 kHz |
| Sensitivity (IHF, Loop antenna) | 350 μV/m |

LW (AM) Tuner Section

(For LW-equipped models only)

| | |
|---------------------------------------|--------------------|
| Frequency range | 153 kHz to 281 kHz |
| Sensitivity (IHF, Loop antenna) | 1,500 μV/m |

Furnished Parts

| | |
|-------------------------|---|
| FM T-type Antenna | 1 |
| AM Loop Antenna | 1 |

Power Supply/Miscellaneous

Power requirements

| | |
|---------------------------|------------------------------------------------------------|
| U.K. model | a.c. 240 Volts~, 50/60 Hz |
| European model | a.c. 220 – 230 Volts~, 50/60 Hz |
| Multi-voltage model | AC 110 V/120 – 127 V/220 V/240 V (switchable), 50/60 Hz |

Power consumption

| | |
|---------------------------------|---------------------------------|
| U.K. and European models | 40 W |
| Multi-voltage model | 50 W |
| AC outlets switched (x 2) | 415 W |
| Dimensions | 360 (W) x 345 (D) x 90.5 (H) mm |
| Weight | 4.5 kg |

5. SCHEMATIC DIAGRAMS AND PCB CONNECTIONS DIAGRAMS

OVERALL WIRING DIAGRAM

- 1.RESISTORS :**
Indicated in Ω , 1/4W, 1/6W and 1/8W, $\pm 5\%$ tolerance unless otherwise noted k; k Ω , M; M Ω , (F); $\pm 1\%$, (G); $\pm 2\%$, (K); $\pm 10\%$, (M); $\pm 20\%$ tolerance.
- 2.CAPACITORS :**
Indicated in capacity (μ F)/voltage(V) unless otherwise noted p; pF. Indication without voltage is 50V except electrolytic capacitor.
- 3.VOLTAGE, CURRENT :**
□ : DC voltage (V) at no input signal unless otherwise noted.
Value in () is DC voltage at rated power.
◁mA or ←mA ; DC current at no input signal unless otherwise noted.
- 4.OTHERS :**
→ : Signal route.
⊙ : Adjusting point
▼(red) : Measuring point
The Δ mark found on some component parts indicates the importance of the safety factor of the part. Therefore, when replacing, be sure to use parts of identical designation.
* marked capacitors and resistors have parts numbers.

- 5. SWITCHES :** (The underlined indicates the switch position)
- DISPLAY ASSEMBLY**
- S701 SURROUND MODE
 - S702 FUNC
 - S703 STATION MEMORY
 - S704 LOCAL/DX
 - S705 SET
 - S706 WAKE UP
 - S707 REC
 - S708 CLOCK ADJ.
 - S709 AUDITION
 - S710 CENTER MODE
 - S711 DELAY TIME
 - S712 POWER
 - S713 BAND
 - S714 FREQ/ST
 - S715 DOWN
 - S716 UP

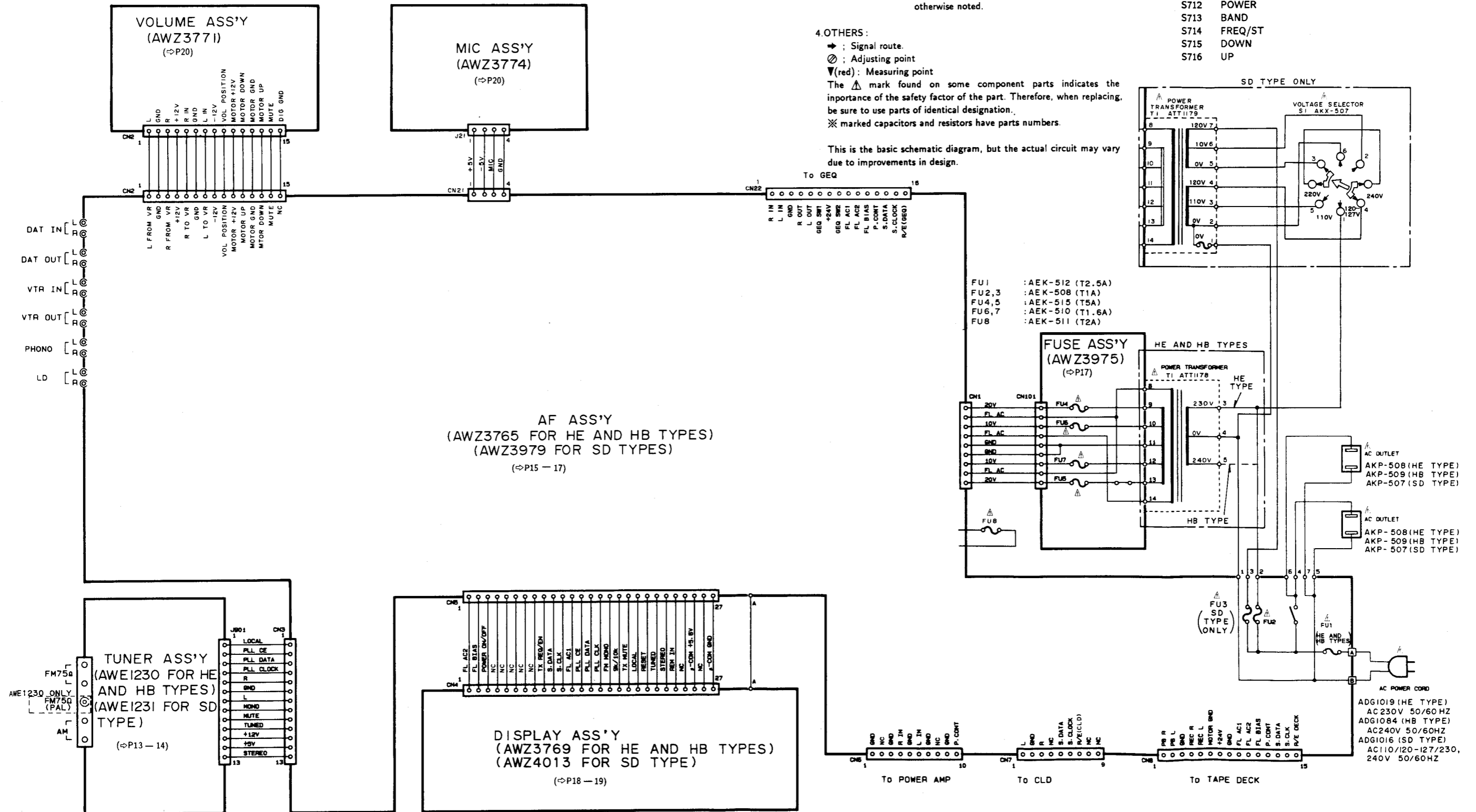

This is the basic schematic diagram, but the actual circuit may vary due to improvements in design.

- FU1 : AEK-512 (T2.5A)
- FU2,3 : AEK-508 (T1A)
- FU4,5 : AEK-515 (T5A)
- FU6,7 : AEK-510 (T1.6A)
- FU8 : AEK-511 (T2A)

- ADG1019 (HE TYPE)
- AC 230V 50/60HZ
- ADG1084 (HB TYPE)
- AC 240V 50/60HZ
- ADG1016 (SD TYPE)
- AC 110/120-127/230, 240V 50/60HZ

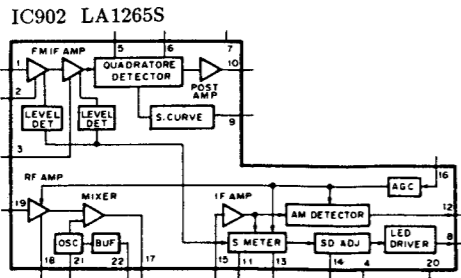

IC902 LA1265S

| Pin No. | Voltage | Pin No. | Voltage | Pin No. | Voltage |
|---------|---------|---------|----------|---------|----------|
| 1 | 2.3 | 10 | 2.8 | 17 | 0 |
| 2 | 2.3 | 11 | 1.5 | 18 | 12.0(AM) |
| 3 | 2.3 | 12 | 1.5 | 18 | 0 |
| 4 | 0 | 13 | 1.4(MAX) | 19 | 2.0(AM) |
| 5 | 12.0 | 14 | 1.4(MAX) | 19 | 0 |
| 6 | 12.0 | 15 | 0(AM) | 20 | 2.0(AM) |
| 7 | 12.0 | 15 | 2.3 | 20 | 3.8 |
| 8 | 0(T) | 16 | 1.1(AM) | 21 | 3.8 |
| 9 | 3.8 | 16 | 1.4 | 22 | 2.8 |
| | | | | | 1.5(AM) |

NOTE: (T): TUNE IND. ON; (D): TUNE IND. OFF.

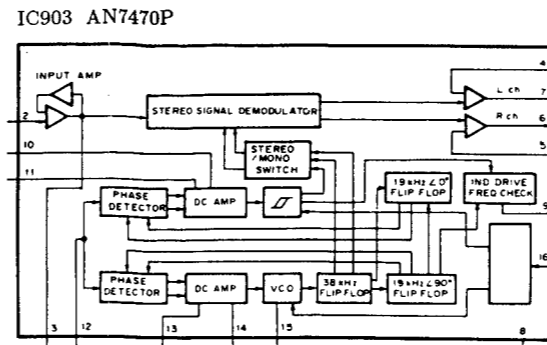

IC903 AN7470P

| Pin No. | Voltage | Pin No. | Voltage | Pin No. | Voltage |
|---------|---------|---------|---------|---------|------------|
| 1 | 11.2 | 9 | 4.9 | 15 | 3.2 |
| 2 | 2.6 | 10 | 0.6 | 16 | 0 |
| 3 | 6.1 | 11 | 2.6 | 16 | 11.4 (AM) |
| 4 | 8.9 | 12 | 2.6 | 16 | 4.0 (MONO) |
| 5 | 8.9 | 13 | 2.6 | | |
| 6 | 3.9 | 14 | 2.6 | | |
| 7 | 3.9 | | | | |
| 8 | 0 | | | | |

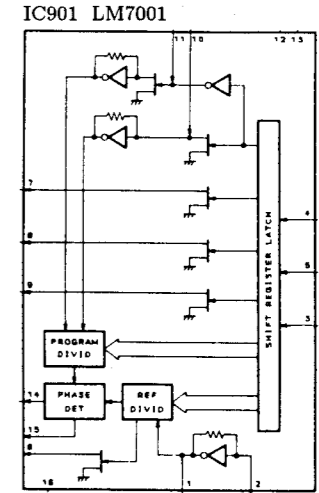

IC901 LM7001

| Pin No. | Voltage | Pin No. | Voltage |
|---------|---------|---------|---------|
| 1 | 1.1 | 9 | 0.46 |
| 2 | 1.5 | 10 | 0 |
| 3 | 0 | 11 | 1.7(AM) |
| 4 | 0 | 12 | 5.0 |
| 5 | 0 | 13 | 5.0 |
| 6 | GND | 14 | 0.7 |
| 7 | — | 15 | — |
| 8 | 0 | 16 | 0 |

TUNER ASS'Y (AWEI230 FOR HE AND HB TYPES)
(AWEI231 FOR SD TYPE)

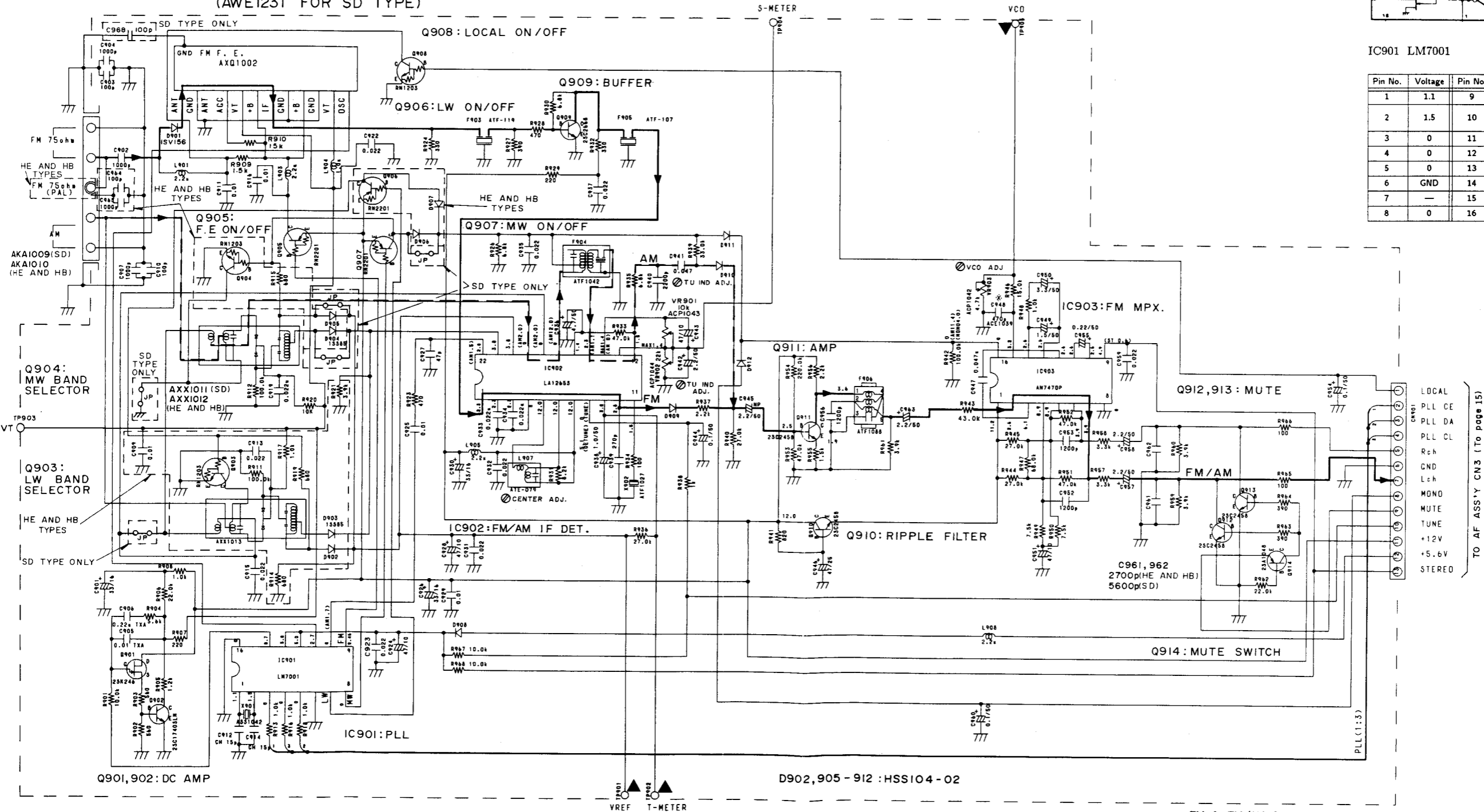

TO AF ASSY CN3 (To page 15)

- LOCAL
- PLL CE
- PLL DA
- PLL CL
- Rch
- CND
- Lch
- MONO
- MUTE
- TUNE
- +12V
- +5.6V
- STEREO

— : FM & FM/AM SIGNAL
- - - : AM SIGNAL

AF AND FUSE ASSY

AF ASS'Y
(AWZ3765 FOR HE AND HB TYPES)
(AWZ3979 FOR SD TYPE)

FUNCTION SELECTION

| | INH | A | B |
|-------|-----|---|---|
| PHONO | L | L | L |
| CLD | L | H | L |
| TUNER | L | L | H |
| TAPE | L | H | H |
| LD | H | L | H |
| VTR | H | H | H |
| DAT | H | L | L |

A: Pin 6 of IC301
B: Pin 7 of IC301
INH: Pin 8 of IC301

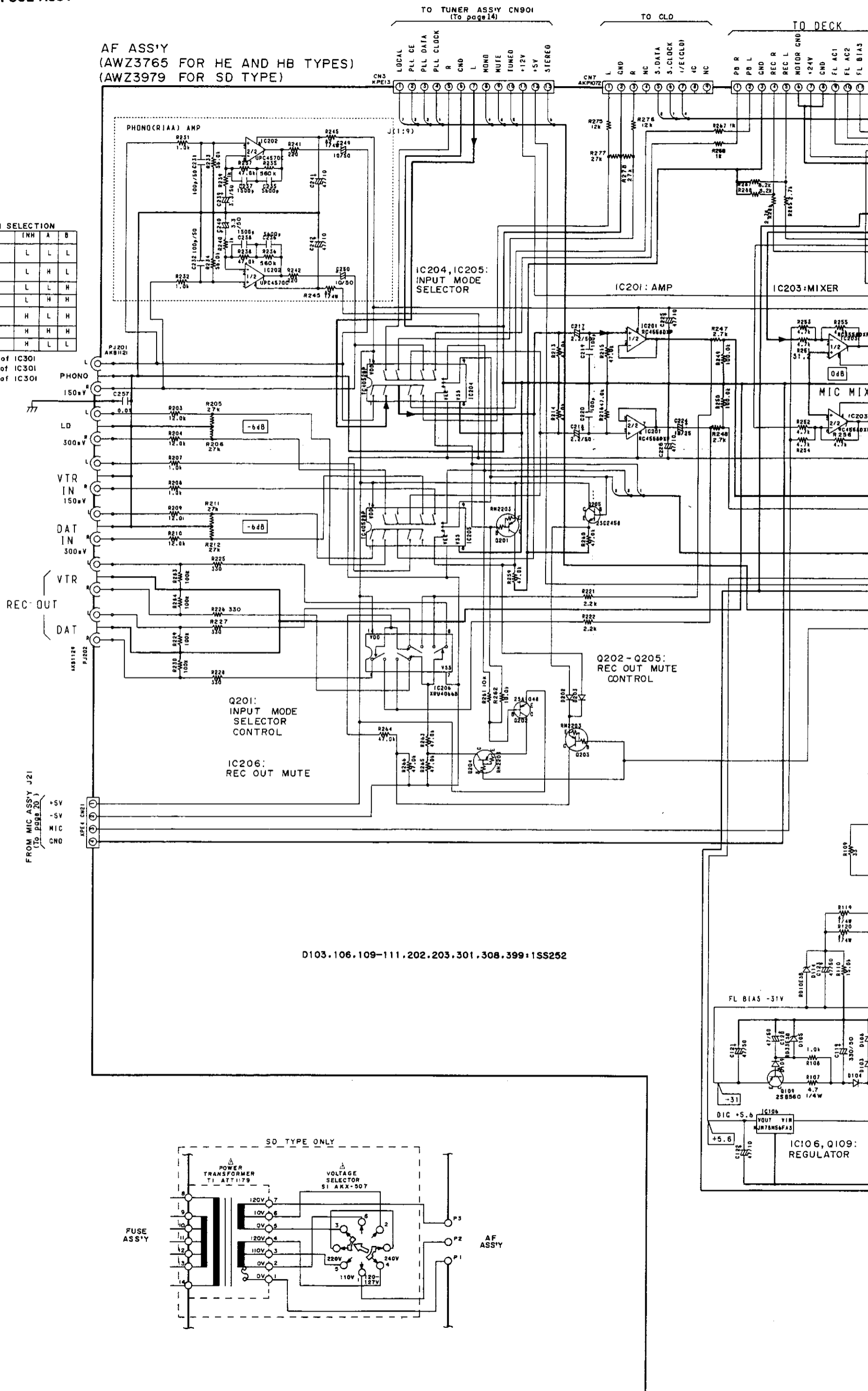

D103, 106, 109-111, 202, 203, 301, 308, 399: 1SS252

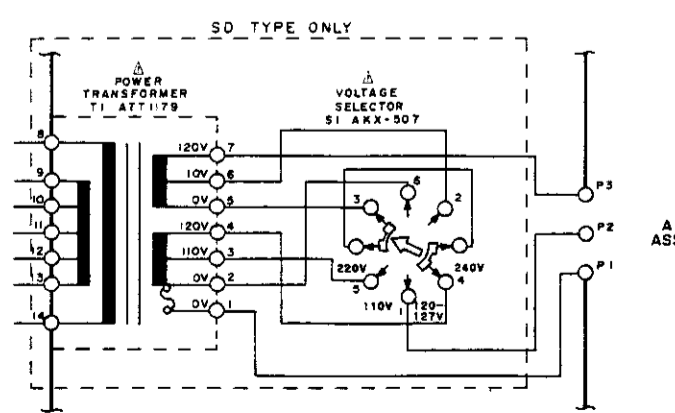
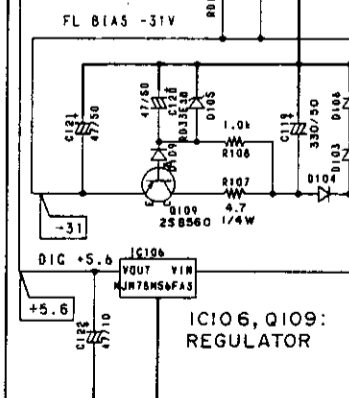

A
B
C
D
E
F

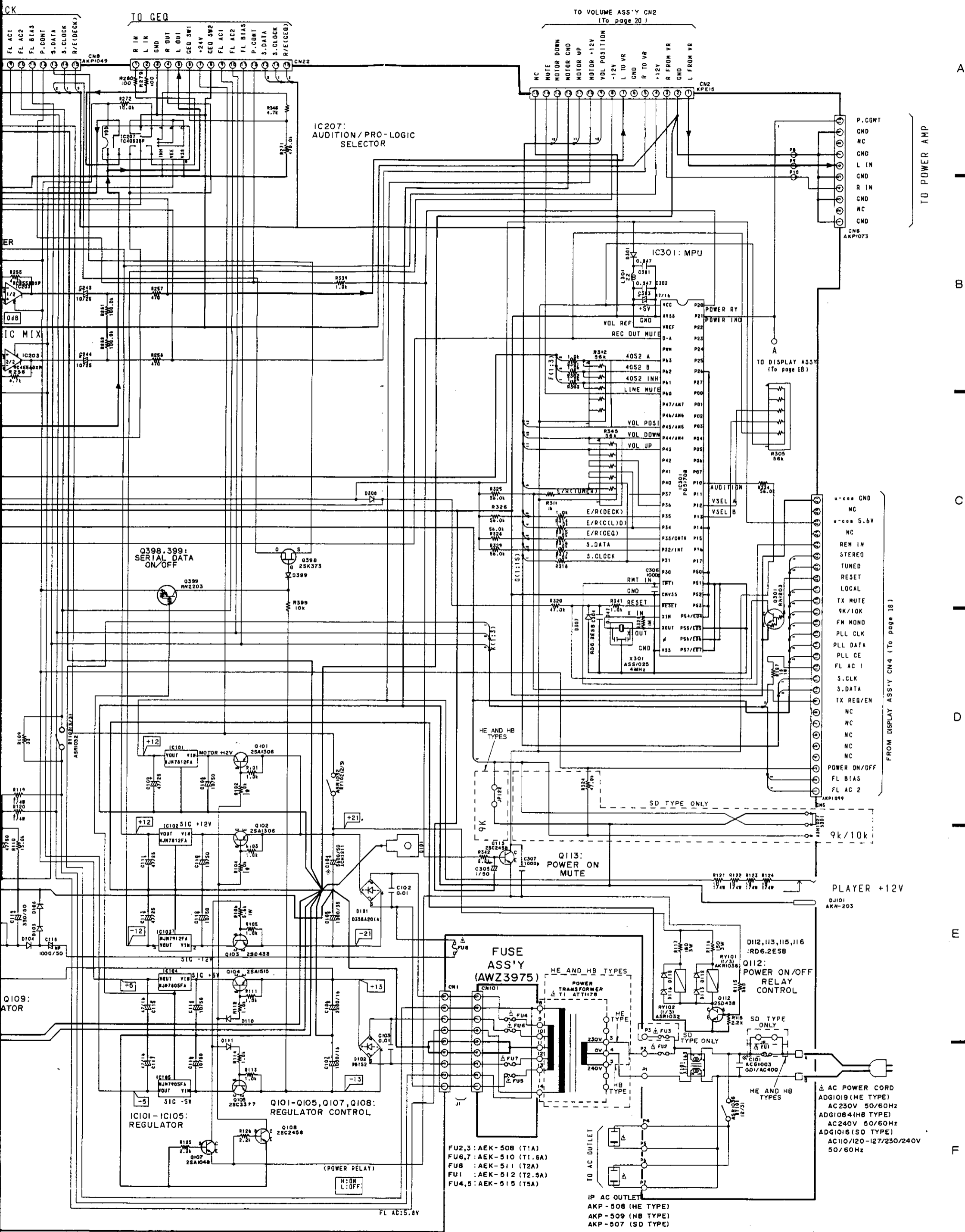

TO POWER AMP

FROM DISPLAY ASS'Y CN4 (To page 18)

PLAYER +12V

FUSE ASS'Y (AWZ3975)

FU2,3 : AEK-508 (T1A)
 FU6,7 : AEK-510 (T1.6A)
 FU8 : AEK-511 (T2A)
 FU1 : AEK-512 (T2.5A)
 FU4,5 : AEK-515 (T5A)

Q112: POWER ON/OFF RELAY CONTROL

SD TYPE ONLY

Q101-Q105, Q107, Q108: REGULATOR CONTROL

Q109: MOTOR

(POWER RELAY)

H: ON
 L: OFF

TO AC OUTLET

AKP-508 (HE TYPE)
 AKP-509 (SB TYPE)
 AKP-507 (SD TYPE)

AC POWER CORD

ADG1019 (HE TYPE)
 AC230V 50/60Hz
 ADG1084 (HB TYPE)
 AC240V 50/60Hz
 ADG1016 (SD TYPE)
 AC110/120-127/230/240V 50/60Hz

A

DISPLAY, VOLUME AND MIC ASSY

B

C

D

E

F

DISPLAY ASS'Y
(AWZ3769 FOR HE AND HB TYPES)
(AWZ4013 FOR SD TYPE)

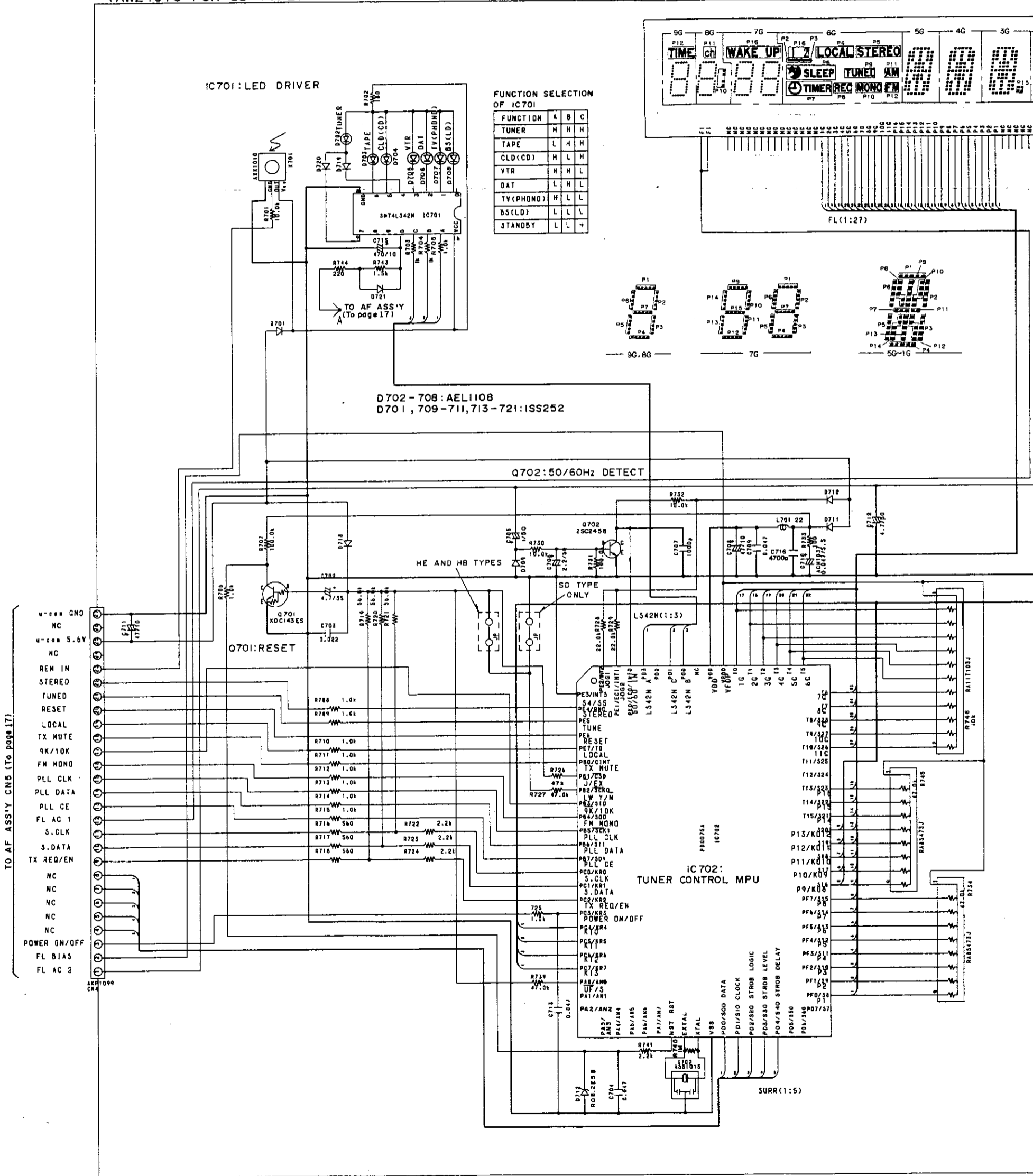

A

B

C

D

E

F

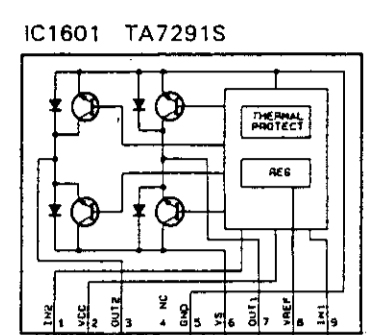
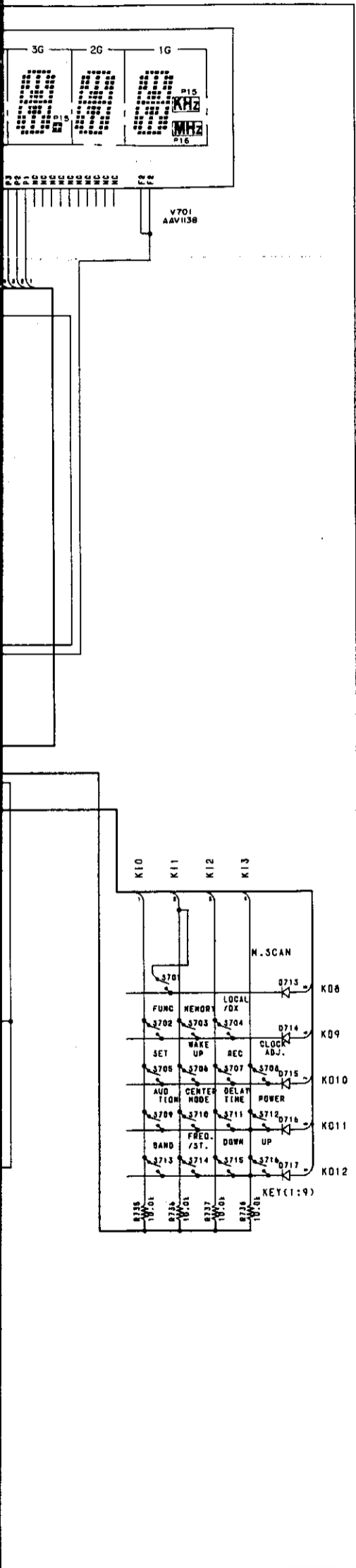

VOLUME ASS'Y (AWZ3771)

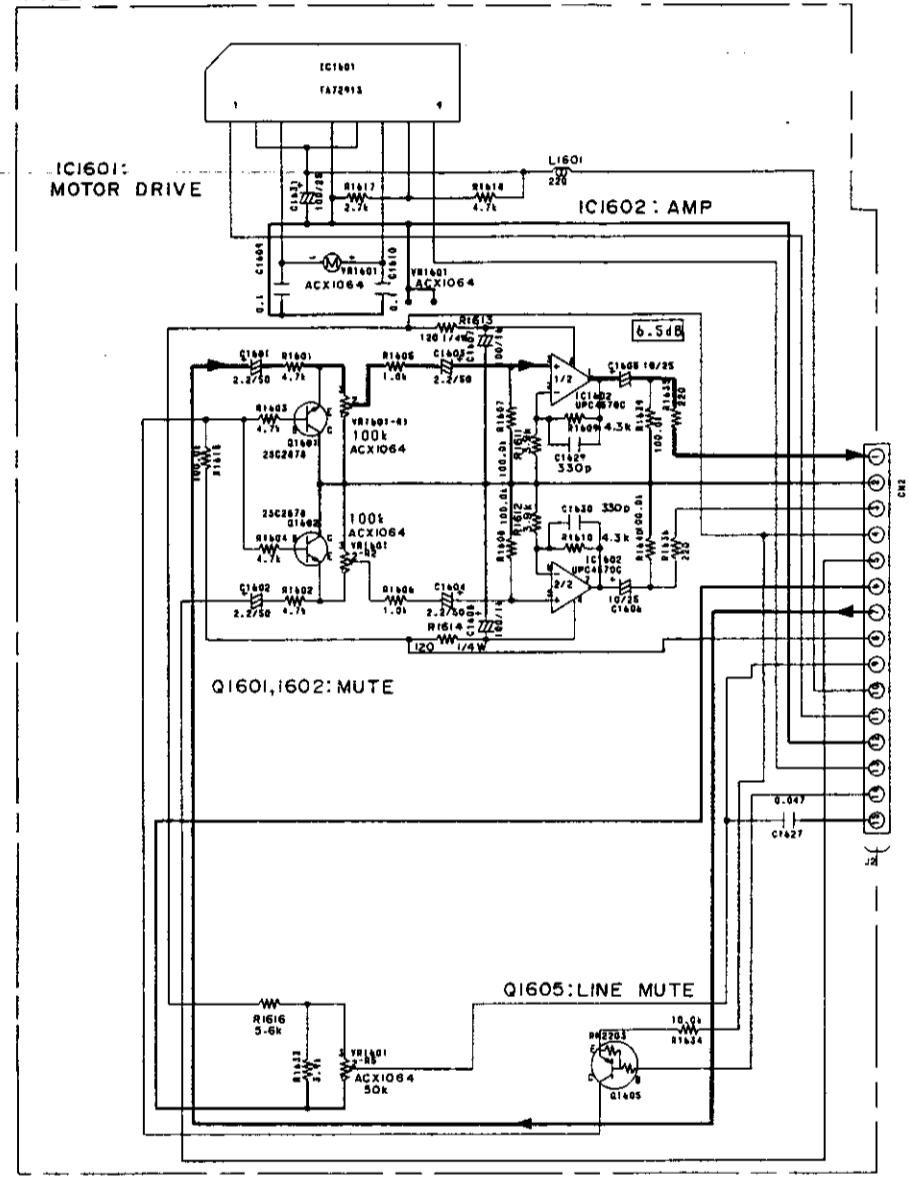

- L CND
 - R
 - +12V
 - R IN
 - CND
 - L IN
 - 12V
 - VOL POSITION
 - MOTOR +12V
 - MOTOR DOWN
 - MOTOR CND
 - MOTOR UP
 - MUTE
 - DIG CND
- TO AF ASS'Y CN2 (To page 17)

MIC ASS'Y (AWZ3774)

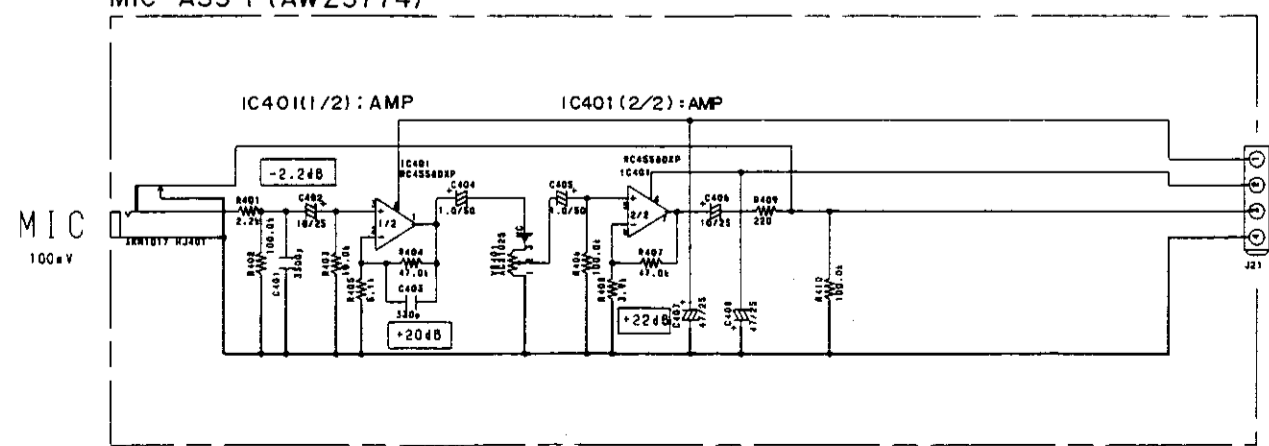

TO AF ASS'Y CN2 (To page 15)

AF ASSY
 (AWZ3765 FOR HE AND HB TYPES)
 (AWZ3979 FOR SD TYPE)

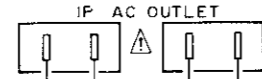

SHIELD ASSY

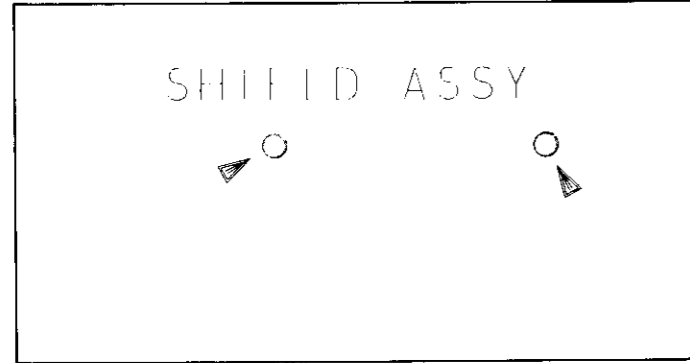

AC POWER CORD

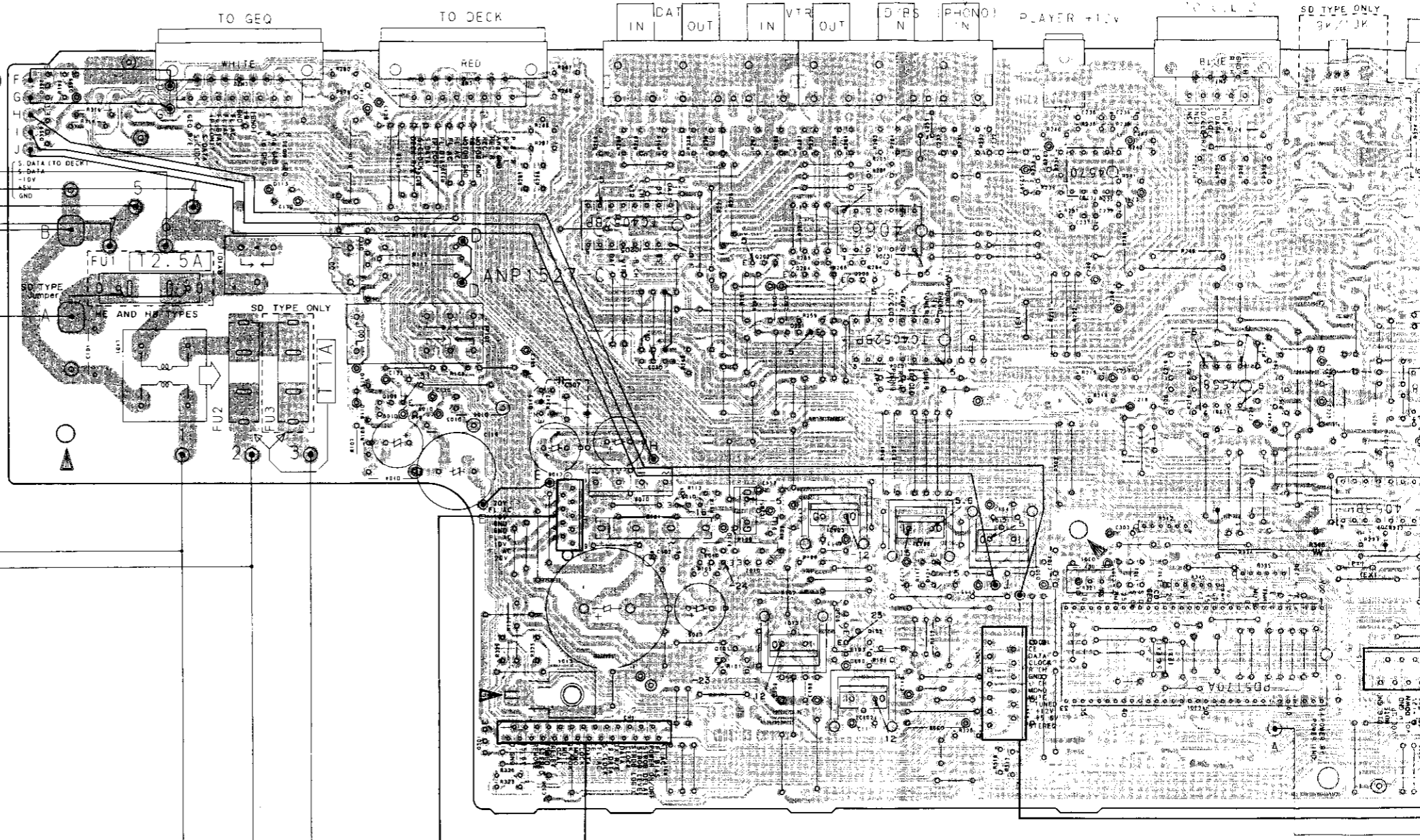

FUSE ASSY
 (AWZ3975)

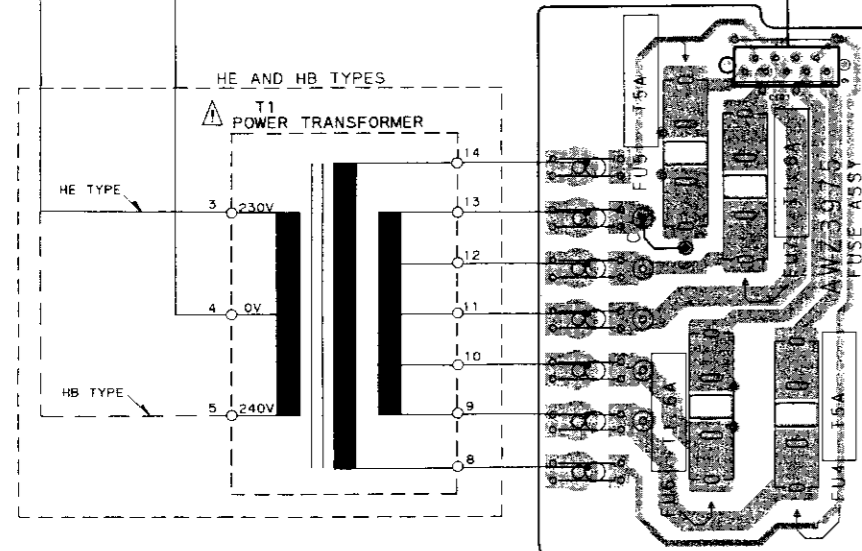

Q398
Q399

Q112
Q109

Q301
Q113

IC205
Q205

Q105
Q103

Q202
Q201

Q204
Q201

IC206
Q203

IC104
IC106

IC202
IC108

IC301
IC106

IC201
IC104

IC207
IC102

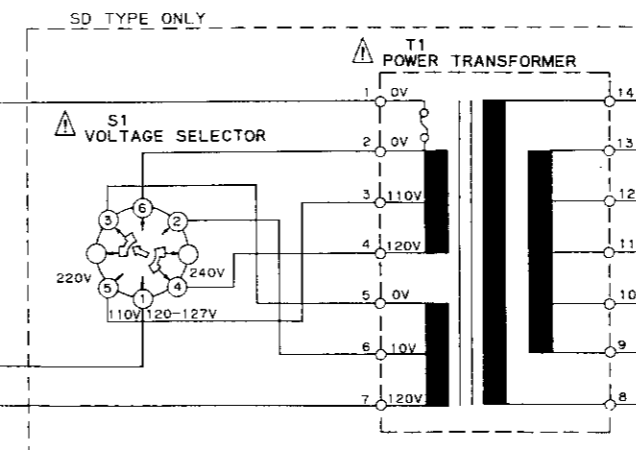

Line Voltage Selection (HE and HB TYPES)

Line voltage can be changed with the following steps.

1. Disconnect the AC power cord.
2. Remove the top cover.
3. Change the connection of the power transformer lead wire.
4. Stick the line voltage label on the rear panel.

| Part No. | Description | |
|----------|-------------|-----------------|
| AXX-193 | 220V label | ----- 220V-230V |
| AXX-192 | 240V label | ————— 240V |

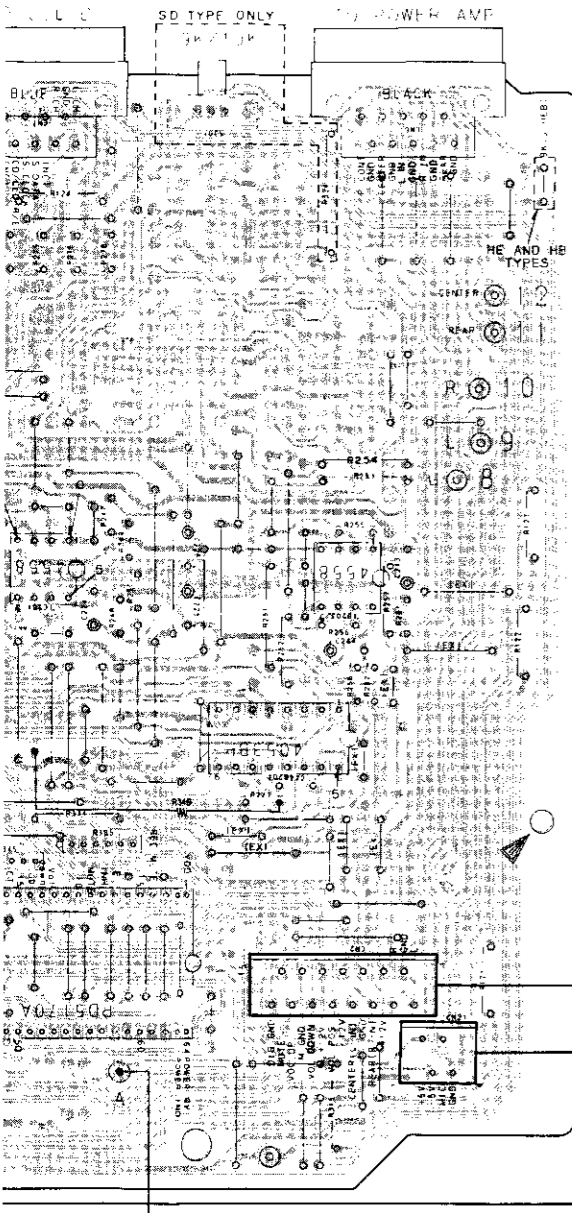

VOLUME ASSY (AWZ3771)

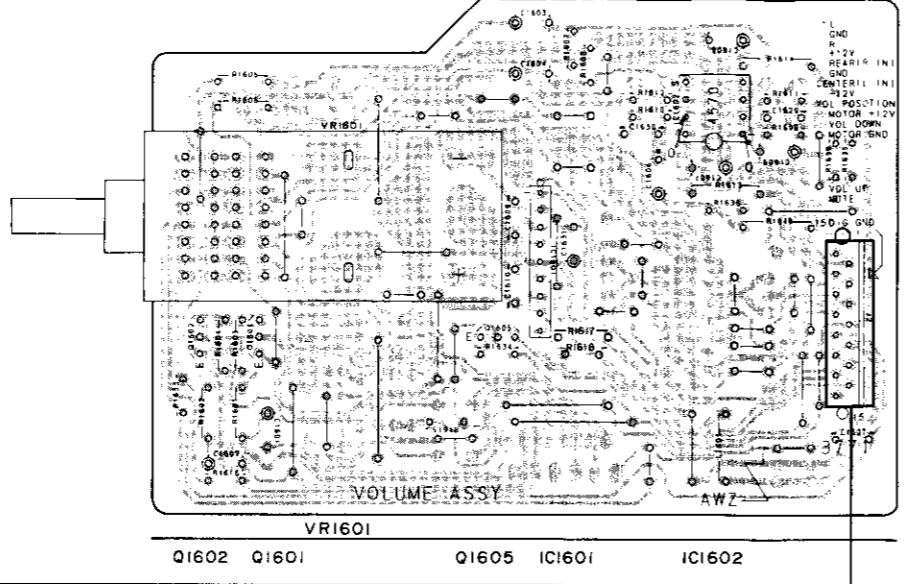

TUNER ASSY (AWEI230 FOR HE AND HB TYPES)
(AWEI231 FOR SD TYPE)

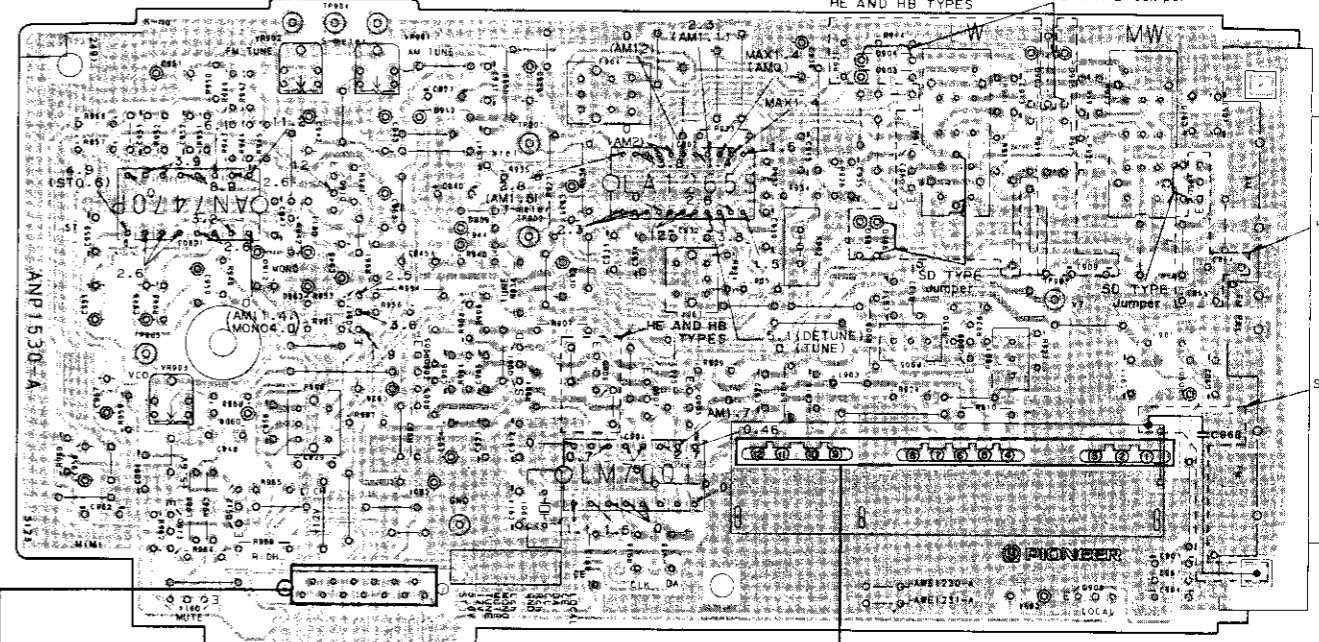

MIC ASSY (AWZ3774)

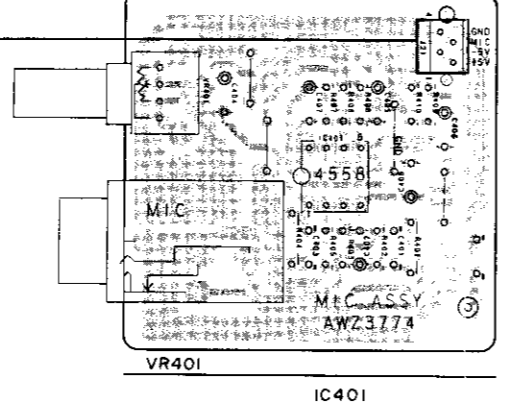

- VR903 VR902 VR901
- IC903 Q913 Q912 Q911 Q914
- Q910 Q902 Q901 Q906 Q907 Q905
- IC902 IC901
- Q903 Q909 Q908 Q904

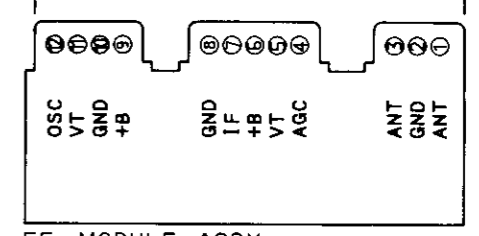

FE MODULE ASSY (AXQ1002)

DISPLAY ASSY (AWZ3769 FOR HE AND HB TYPES)
(AWZ4013 FOR SD TYPE)

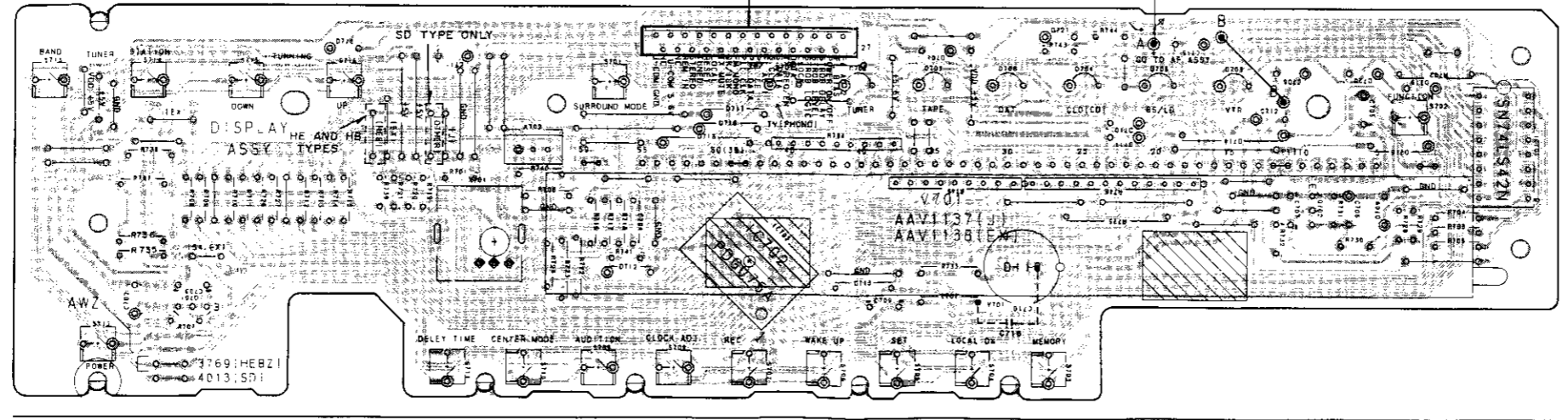

- NOTE
- This P.C.B connection diagram is viewed from the parts mounted side.
 - The parts which have been mounted on the board can be replaced with those shown with the corresponding wiring symbols listed in the following table.

| P.C.B. pattern diagram indication | Corresponding part symbol | Part Name |
|-----------------------------------|---------------------------|--------------------------|
| | | Transistor |
| | | Radiator type transistor |
| | | Diode |
| | | Resistor |
| | | Capacitor (Polarity) |
| | | Capacitor (Non-polarity) |

Others

| P.C.B. pattern diagram indication | Part Name |
|-----------------------------------|------------------------------------------|
| IC | IC |
| S | Switch |
| RY | Relay |
| L | Coil |
| F | Filter |
| VR | Variable resistor or Semi-fixed resistor |

- The capacitor terminal marked with ⊕ (double circles) shows negative terminal.
- The diode terminal marked with ⊕ (double circles) shows cathode side.
- The transistor terminal to which E is affixed shows the emitter.

ES) steps.
mer lead wire.
0V - 230V
0V

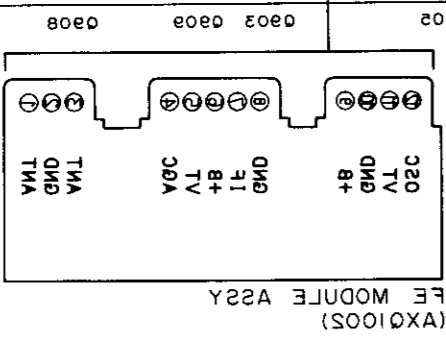
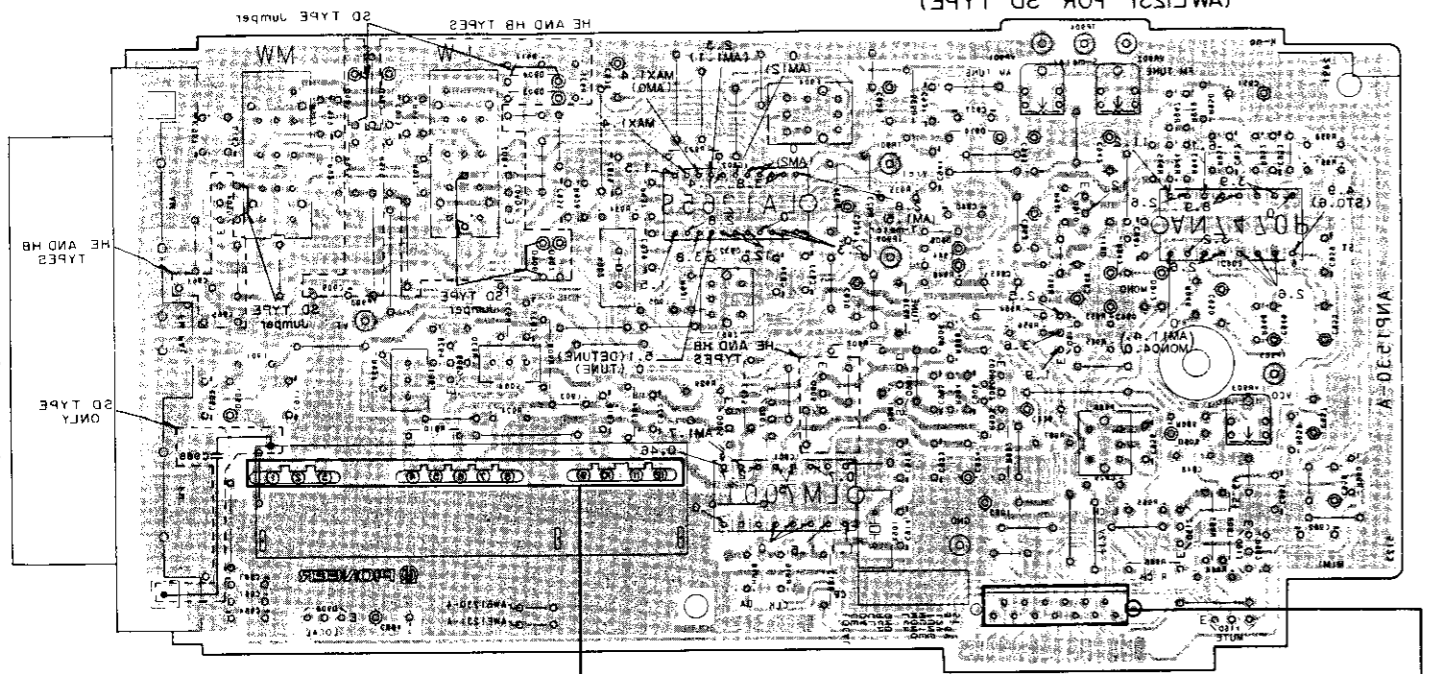
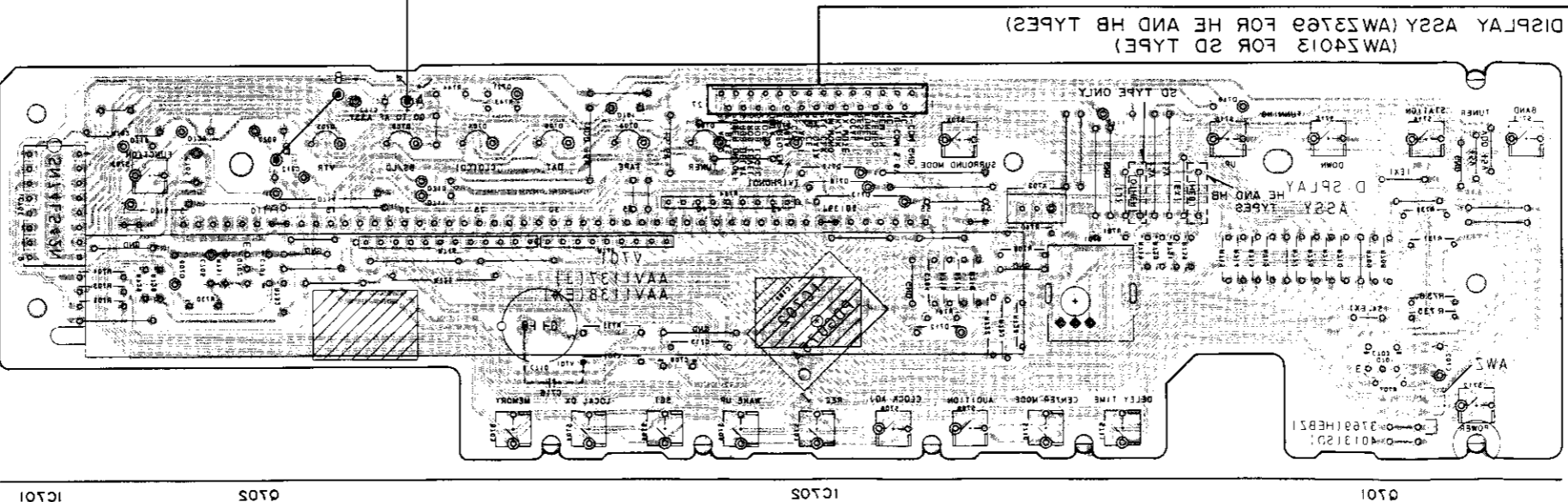
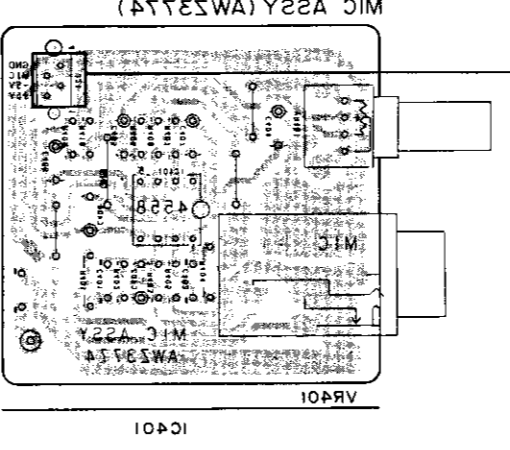
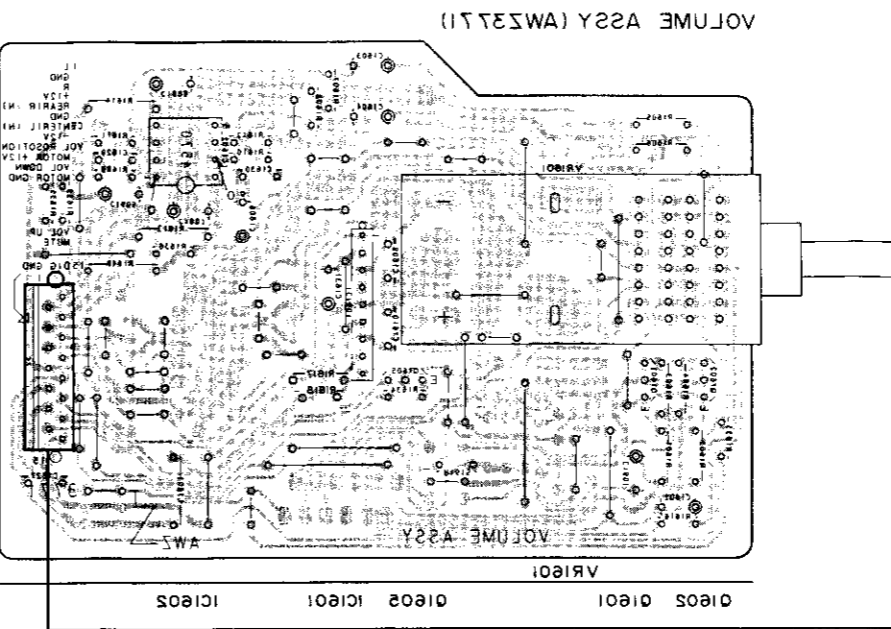
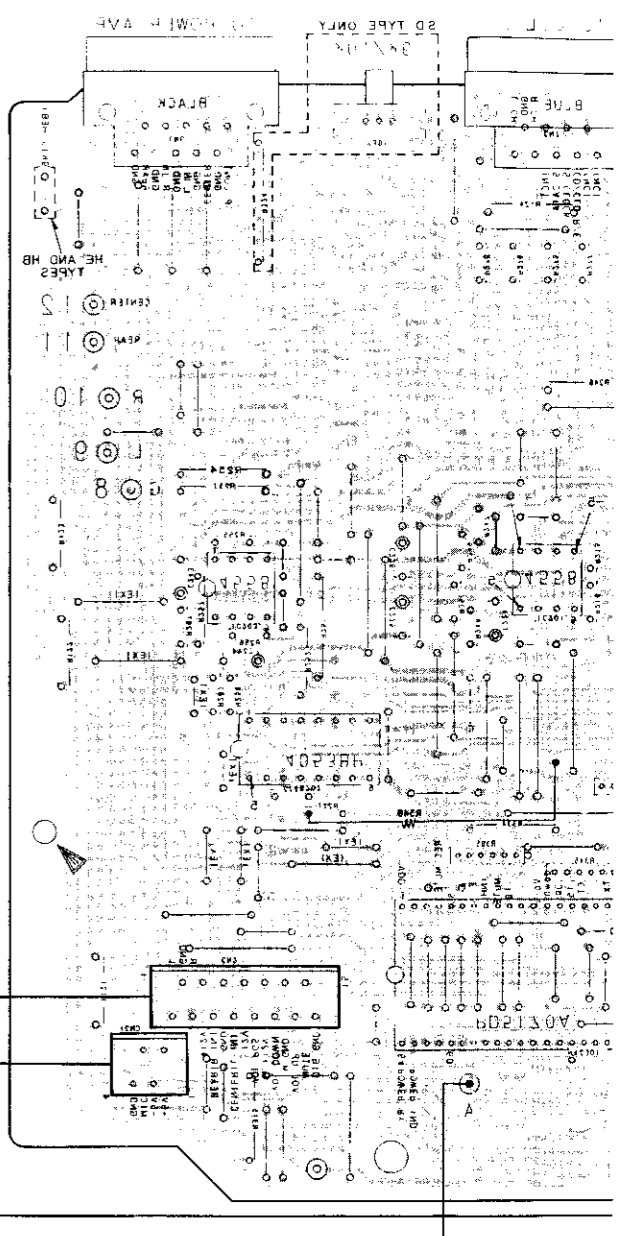

This P.C.B. connection diagram is viewed from the foil side.

TUNER ASSY (AW3753 FOR HE AND HB TYPES)

VOLUME ASSY (AW3771)

MIC ASSY (AW3774)

DISPLAY ASSY (AW3769 FOR HE AND HB TYPES)

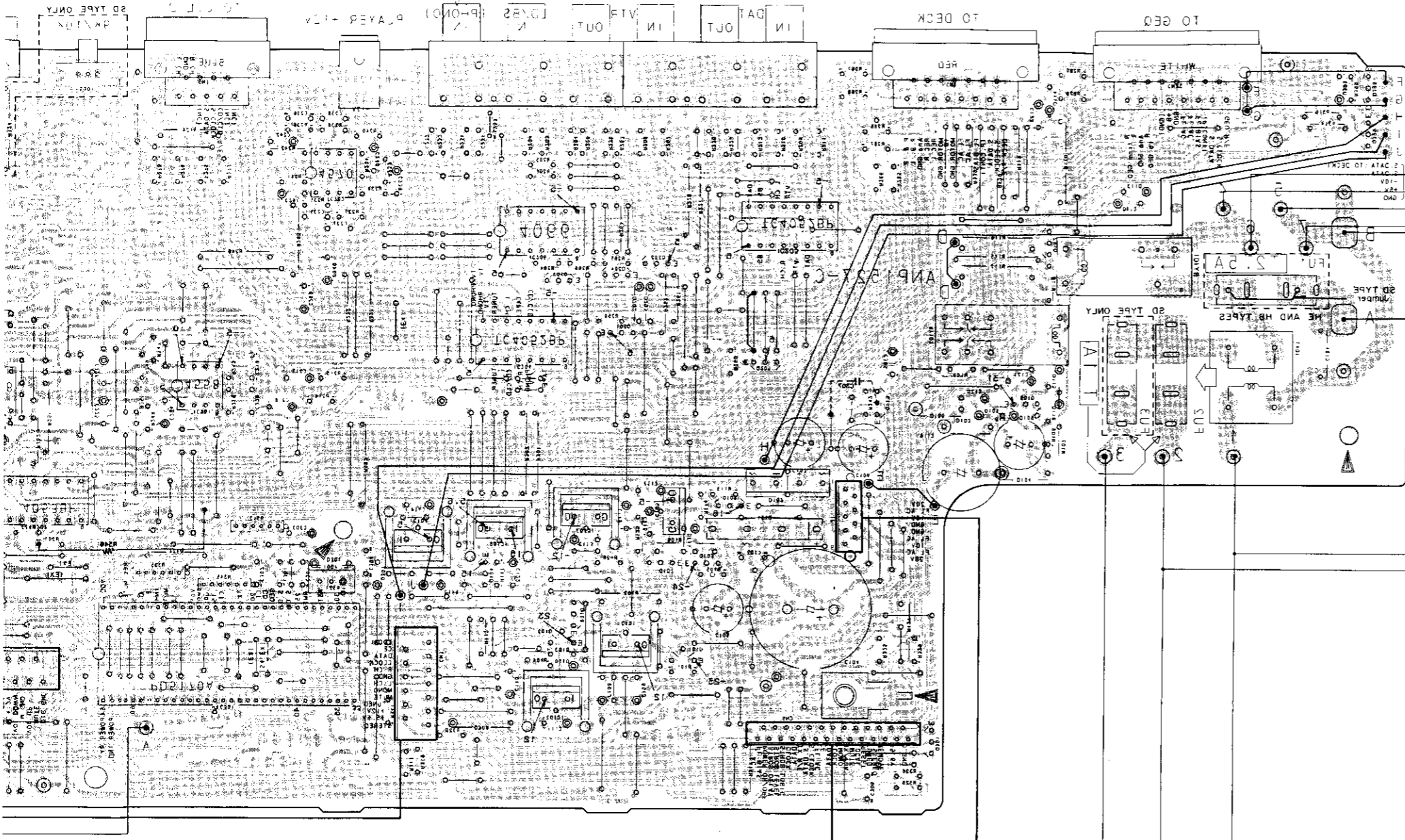

AF ASSY
(AW3375 FOR HE AND HB TYPES)
IP AC OUTLET

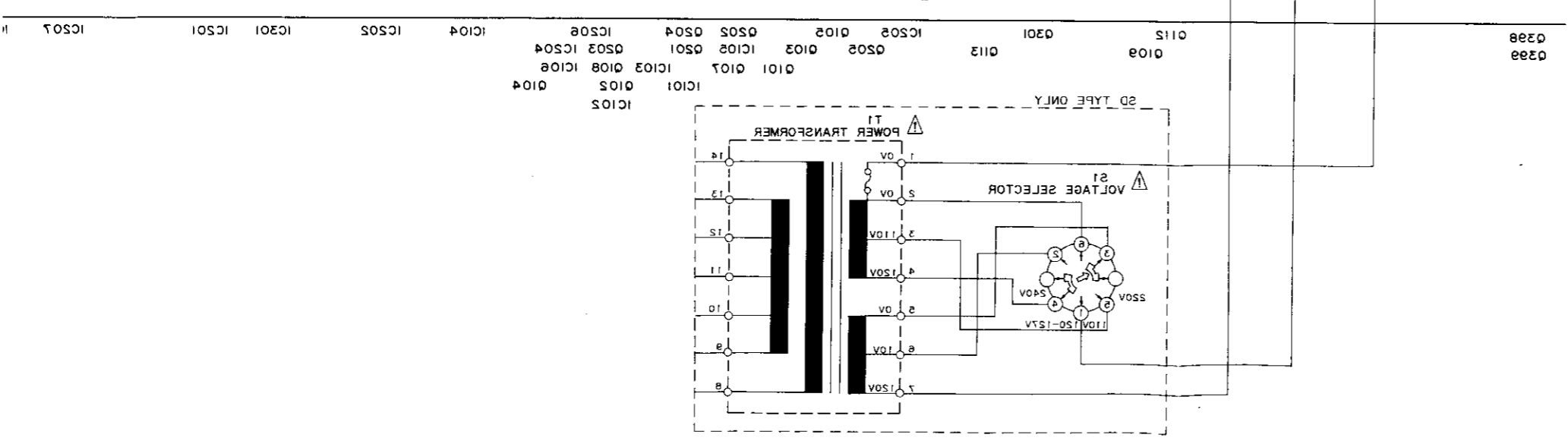
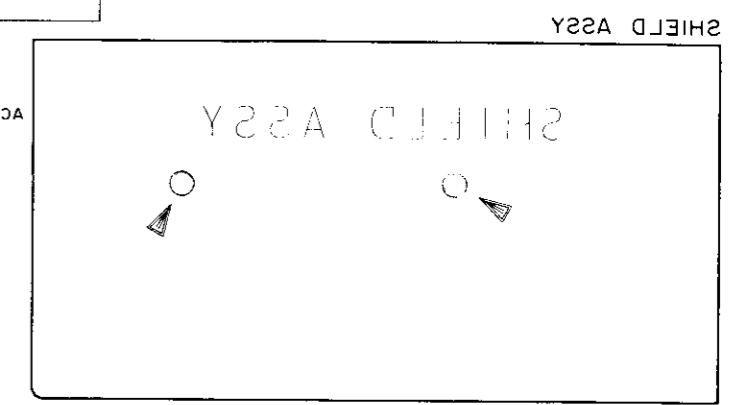
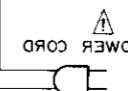
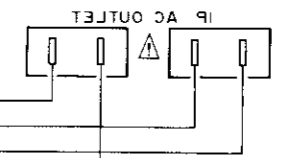

IC105
IC101 Q105 Q104
IC103 Q108 IC108
IC102 Q103 Q501 IC108 Q504
IC104 IC301 IC501
IC505 IC508
IC502 Q102 Q505 Q504
Q301 Q301
Q115 Q115
Q303 Q303

FUSE ASSY
(AW3375)

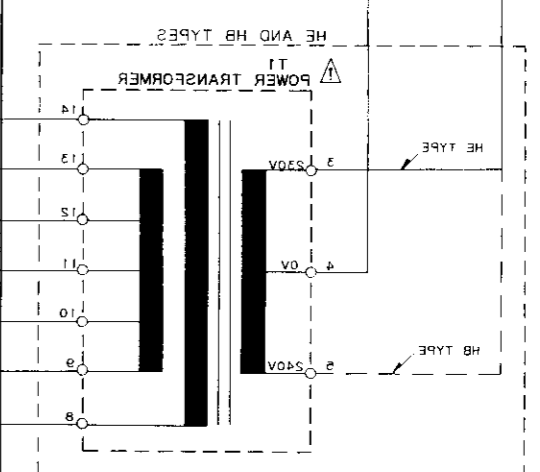
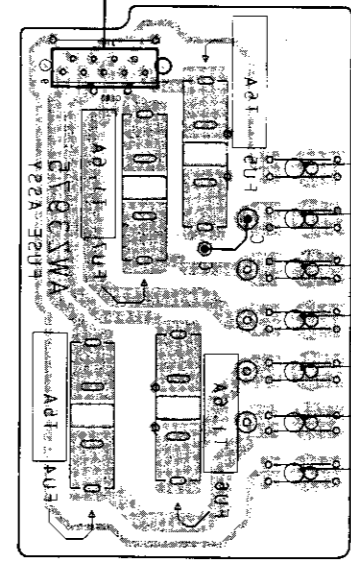

A

B

C

D

e

2

4

3

5

1

e

2

4

3

5

1

6. ADJUSTMENTS

- As to connections and points to be adjusted, refer to Fig. 6-1, Fig. 6-2 and Fig. 6-3.

6.1 AM TUNER ADJUSTMENT

- Set the BAND selector to "AM".

| Step No. | Adjustment Title | AM SG(400Hz, 30% modulation) | | Reception Frequency Display | Adjustment | |
|----------|----------------------------------------|------------------------------|---------------------|-----------------------------|---------------------|-----------------------------------------|
| | | Frequency(kHz) | Level(dB μ V/m) | | Adjustment Location | Specifications |
| 1 | TUNED indicator sensitivity adjustment | 999 | 55 \pm 5 | 999kHz | VR901 | Adjust so that the indicator lights up. |

6.2 FM TUNER ADJUSTMENT

- Set the BAND selector to "FM".
- Perform VCO adjustment two minutes or more after turning the power ON.

Note : Stereo modulation : Main 1 kHz L + R \pm 68.25 Hz dev.
Pilot 19 kHz \pm 6.75 kHz dev .

| Step No. | Adjustment Title | FM SG(1kHz \pm 75kHz dev.) | | Reception Frequency Display | Adjustment | |
|----------|----------------------------------------|------------------------------|-------------------|-----------------------------|---------------------|-----------------------------------------------------------------------|
| | | Frequency(MHz) | Level(dB μ V) | | Adjustment Location | Specifications |
| 1 | Detector coil T-meter adjustment | 98.0 | 80 | 98.0MHz | L907 | Adjust so that the DC voltage between TP901 and TP902 is \pm 50mV. |
| 2 | VCO adjustment | 98.0 (No modulation) | 80 | 98.0MHz | VR903 | Adjust so that the frequency between TP905 and GND is 76 \pm 0.5kHz |
| 3 | TUNED indicator sensitivity adjustment | 98.0 | 18 \pm 3 | 98.0MHz | VR902 | Adjust so that the indicator lights up. |

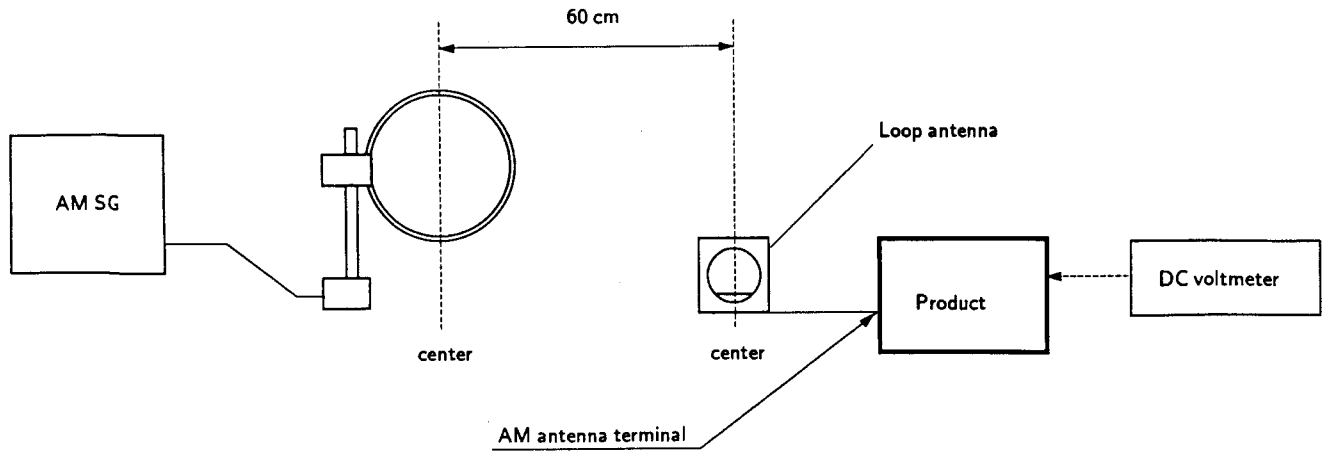

Fig. 6-1 AM Adjustment Connection Diagram

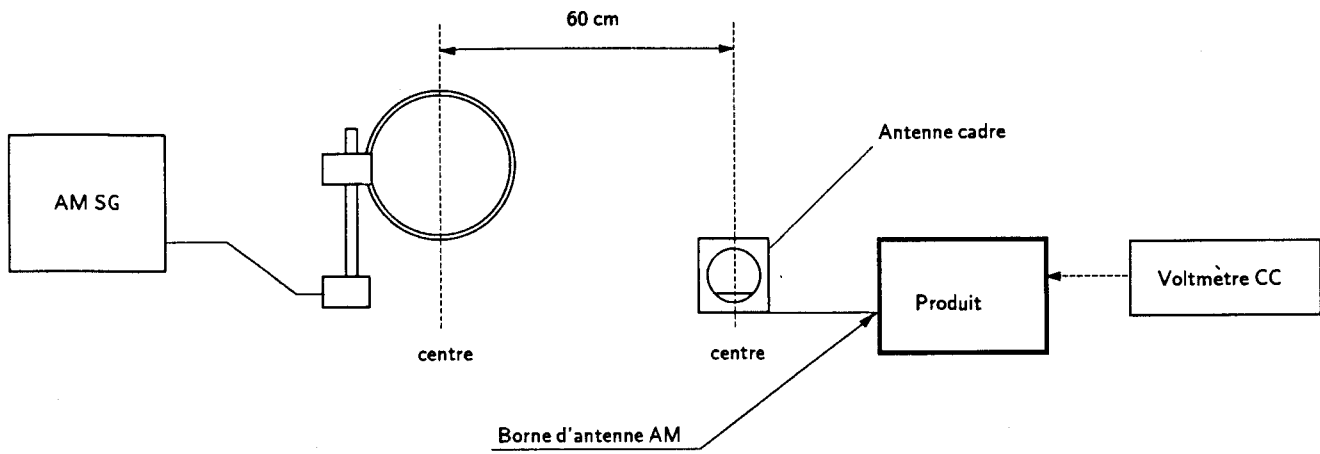

Fig. 6-1 Schéma de raccordement de réglage AM

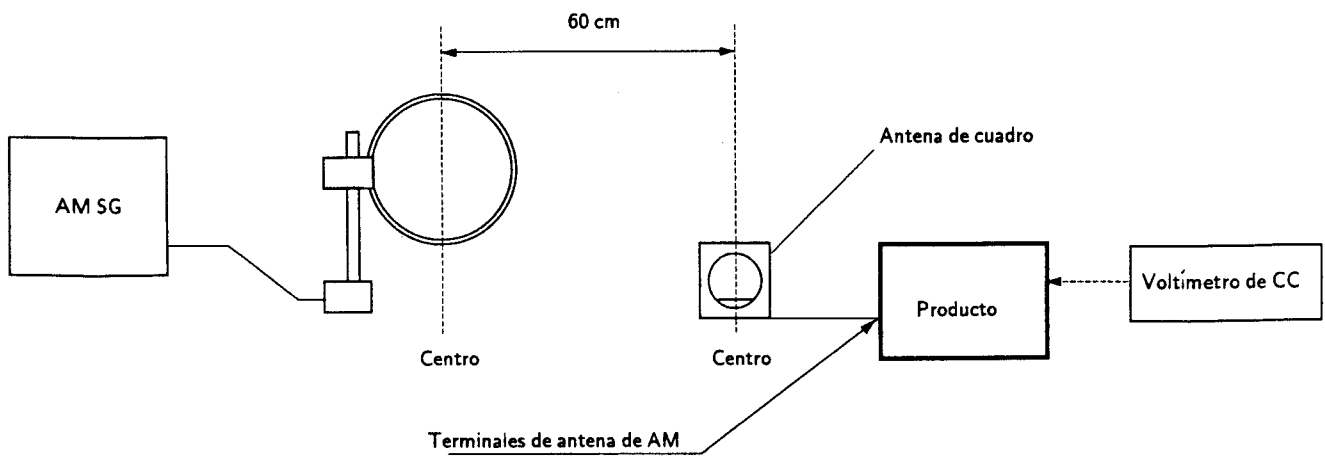

Fig. 6-1 Diagrama de conexiones para el ajuste de AM

6. AJUSTE

● Para las conexiones y puntos de ajuste, refiérase a la Fig. 6-1, Fig. 6-2 y Fig. 6-3.

6.1 AJUSTE DE LA SECCION DEL SINTONIZADOR DE AM

● Ajuste el selector BAND a la posición "AM".

| N°. de paso | Items de ajuste | AM SG(400Hz, 30% modulation) | | Frecuencimetro de resepción | Ajuste | |
|-------------|-------------------------------|------------------------------|---------------------|-----------------------------|-----------------|------------------------------------------------------------------------|
| | | Frecuencia(kHz) | Nivel(dB μ V/m) | | Lugar de ajuste | Especificaciones |
| 1 | Nivel de iluminación de TUNED | 999 | 55 \pm 5 | 999kHz | VR901 | Ajustelo de forma que los indicadores de TUNED comiencen a encenderse. |

6.2 AJUSTE DE LA SECCION DEL SINTONIZADOR DE FM

● Ajuste el selector BAND a la posición "FM".

● Realice el ajuste VCO dos minutos o mas despues de conectar la alimentacion.

*Nota : Modulacion estereo : Principal : 1 kHz L + R \pm 68,25 Hz dev.
Pilote 19 kHz \pm 6,75 kHz dev.*

| N°. de paso | Items de ajuste | FM SG(1kHz \pm 75kHz dev.) | | Frecuencimetro de recepción | Ajuste | |
|-------------|---------------------------------------------|------------------------------|-------------------|-----------------------------|-----------------|------------------------------------------------------------------------------|
| | | Frecuencia(MHz) | Nivel(dB μ V) | | Lugar de ajuste | Especificaciones |
| 1 | Ajuste del medidor T de la bobina detectora | 98,0 | 80 | 98,0MHz | L907 | Ajuste de manera que la tensión de CC entre TP901 y TP902 sea de \pm 50mV. |
| 2 | Ajuste VCO | 98,0 (Sin modulación) | 80 | 98,0MHz | VR903 | Ajuste de manera que la frecuencia entre TP905 y GND sea de 76 \pm 0,5kHz |
| 3 | Nivel de iluminación de TUNED | 98,0 | 18 \pm 3 | 98,0MHz | VR902 | Ajustelo de forma que los indicadores de TUNED comiencen a encenderse. |

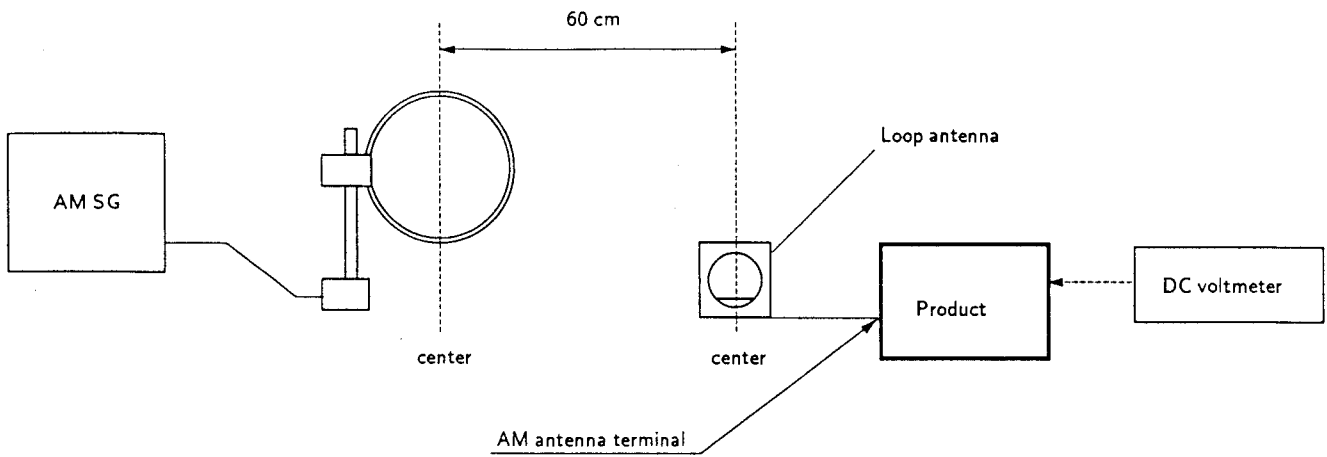

Fig. 6-1 AM Adjustment Connection Diagram

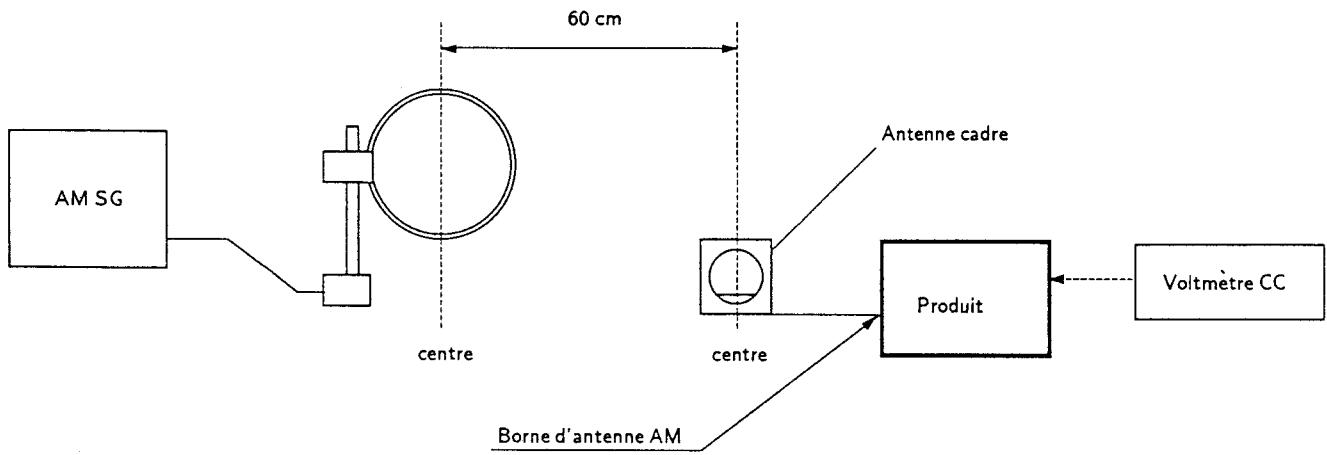

Fig. 6-1 Schéma de raccordement de réglage AM

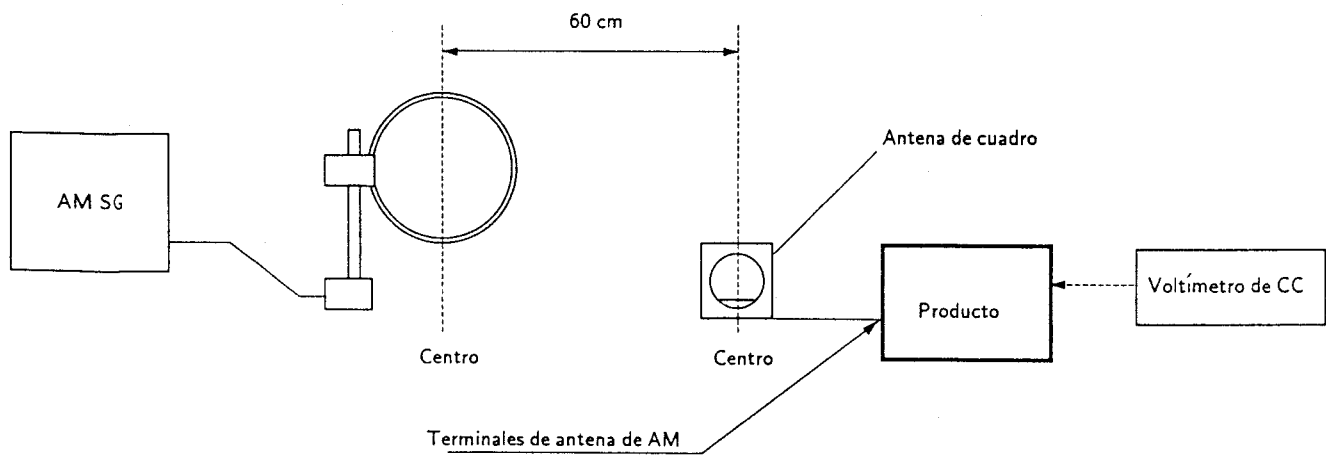

Fig. 6-1 Diagrama de conexiones para el ajuste de AM

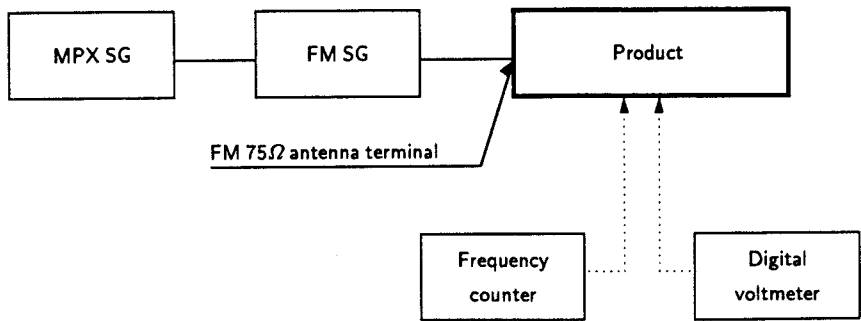

Fig. 6-2 FM Adjustment Connection Diagram

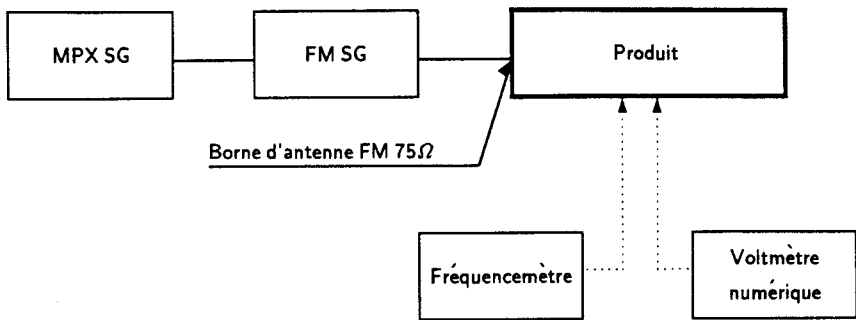

Fig. 6-2 Schéma de connexion de réglage FM

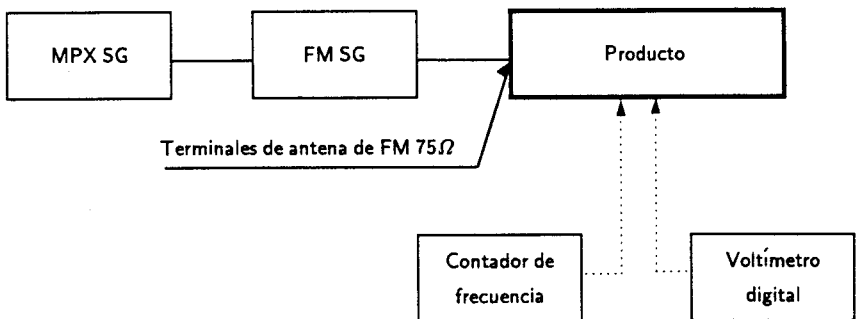

Fig. 6-2 Diagrama de conexiones para el ajuste de FM

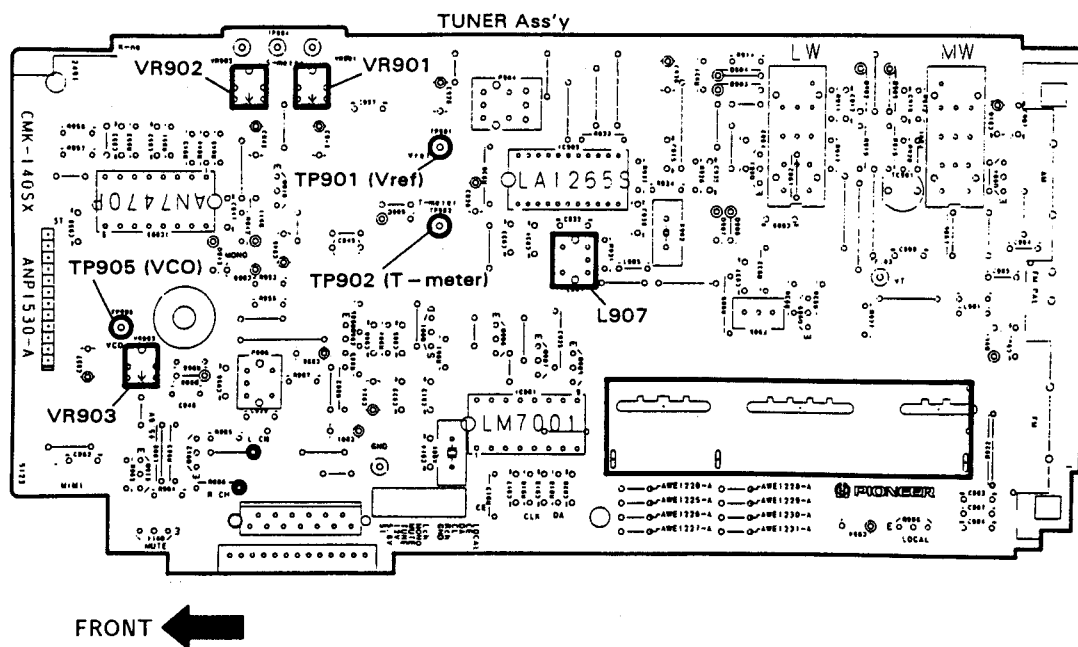

Fig. 6-3 Adjustment Points
 Fig. 6-3 Emplacements de réglage
 Fig. 6-3 Puntos de ajuste

7. FOR HB AND SD TYPES

NOTES :

- Parts without part number cannot be supplied.
- Parts marked by “●” are not always kept in stock. Their delivery time may be longer than usual or they may be unavailable.
- The ▲ mark found on some component parts indicates the importance of the safety factor of the part. Therefore, when replacing, be sure to use parts of identical designation.

CONTRAST OF MISCELLANEOUS PARTS

CX-J500/HB, SD and CX-J500/HE have the same construction except for the following :

| Mark | Symbol & Description | Part No. | | | Remarks |
|------|--------------------------------------------------------|---------------------|---------------------|---------------------|------------|
| | | CX-J500/ HE type | CX-J500/ HB type | CX-J500/ SD type | |
| ● | AF assembly | AWZ3765 | AWZ3765 | AWZ3979 | |
| ● | DISPLAY assembly | AWZ3769 | AWZ3769 | AWZ4013 | |
| | TUNER assembly | AWE1230 | AWE1230 | AWE1231 | |
| ▲ | AC power cord | ADG1019 | ADG1084 | ADG1016 | |
| ▲ | FUSE (FU3 T1A/250V) | | | AEK-508 | No. 38 (*) |
| ▲ | FUSE (FU1 T2.5A/250V) | AEK-512 | AEK-512 | | No. 44 (*) |
| ▲ | AC outlet 1P | AKP-508 | AKP-509 | AKP-507 | |
| ▲ | Line Voltage Selector (S1) (AC110/120-127/220/240V) | | | AKX-507 | |
| ▲ | Power transformer (T1) | ATT1178 | ATT1178 | ATT1179 | |

* : Refer to page 2.

AF ASSEMBLIES

AWZ3979 and AWZ3765 have the same construction except for the following :

| Mark | Symbol & Description | Part No. | | Remarks |
|------|----------------------|----------------|------------------------|---------|
| | | AWZ3765 | AWZ3979 | |
| | S301 R324 | | ASH1027 RD1/8PM473J | |

DISPLAY ASSEMBLIES

AWZ4013 and AWZ3769 are different in part number, but they have the same service parts.

TUNER ASSEMBLIES

AWE1231 and AWE1230 have the same construction except for the following :

| Mark | Symbol & Description | Part No. | | Remarks |
|------|----------------------------------------------------|------------------------------------------------------------------------------------|----------------------------------------------------------------|---------|
| | | AWE1230 | AWE1231 | |
| | Q903, 904 Q906 | RN1203 RN2201 | | |
| | D902, 905-907 D903, 904 | HSS104-02 1SS85 | | |
| | C909 C913 C961, 962 C964 C965 C968 | CKDYF103Z50 CKDYF223Z50 CKDYB272K50 CKPUYB101K50 CKPUYB102K50 | CKDYB562K50 CCDSL101J50 | |
| | R911 R914, 915, 919 R917 R921 | RD1/8PM104J RD1/8PM681J RD1/8PM102J RD1/8PM392J | | |
| | ANTENNA TERMINAL (4P) ANTENNA TERMINAL (PAL 4P) | AKA1010 | AKA1009 | |
| | AM RF TUNING BLOCK (MW) AM RF TUNING BLOCK (LW) | AXX1012 AXX1013 | AXX1011 | |