

Service Manual

PIONEER
The Art of Entertainment



ORDER NO.
ARP2401

TUNER CONTROL AMPLIFIER

CX - J400

CX - J300

CX - J400 AND CX - J300 HAVE THE FOLLOWING :

Type	Model		Power Requirement	Remarks
	CX - J400	CX - J300		
HE	○	○	AC 220 V - 230 V, 240 V (switchable)*	
HEWZI	○	○	AC 220 V - 230 V, 240 V (switchable)*	
HB	○	○	AC 220 V - 230 V, 240 V (switchable)*	
SD 2	-	○	AC 110 V, 120 V - 127 V, 220 V, 240 V (switchable)	
YPW 2	-	○	AC 240 V only	

* Change the connection of the power transformer's primary wiring.

- This manual is applicable to the following : CX - J400/HE and HB ; CX - J300/HE and HB.
- As to the following : CX - J400/HB ; CX - J300/HE and HB, refer to page 35.
- As to the other type(s), refer to applicable service manual(s).
- These products are systems components. Each of these products does not function properly when independent ; to avoid malfunctions, be sure to connect it to the prescribed system component(s), otherwise damage may result.
- These products' instructions are contained within the operating instructions manual of the related system component(s).
- The manual is packed with those component(s). These products' accessories etc. are packed with their related component(s).
- Ce manuel pour le service comprend les explications de réglage en fran cais.
- Este manual de servicio trata del método ajuste escrito en español.

CONTENTS

1. EXPLODED VIEWS AND PARTS LIST	2	6. ADJUSTMENTS	29
2. PCB PARTS LIST	5	6. REGLAGE	30
3. PANEL FACILITIES	8	6. AJUSTE	31
4. SPECIFICATIONS	10	7. FOR CX - J400/HB ; CX - J300/HE AND HB	35
5. SCHEMATIC DIAGRAMS AND PCB CONNECTIONS DIAGRAMS	11		

PIONEER ELECTRONIC CORPORATION 4-1, Meguro 1-Chome, Meguro-ku, Tokyo 153, Japan
PIONEER ELECTRONICS SERVICE INC. P.O. Box 1760, Long Beach, California 90801 U.S.A.
PIONEER ELECTRONICS OF CANADA, INC. 505 Cochrane Drive, Markham, Ontario L3R 8E3 Canada
PIONEER ELECTRONIC [EUROPE] N.V. Haven 1087 Keetberglaan 1, 9120 Melsele, Belgium
PIONEER ELECTRONICS AUSTRALIA PTY. LTD. 178-184 Boundary Road, Braeside, Victoria 3195, Australia TEL: [03] 580-9911

© PIONEER ELECTRONIC CORPORATION 1992

FS JAN. 1992. Printed in Japan

1. EXPLODED VIEWS AND PARTS LIST

NOTES :

- The parts with an encircled number are generally unavailable because they are not in our Master Spare Parts List.
- The Δ mark found on some component parts indicates the importance of the safety factor of the part. Therefore, when replacing, be sure to use parts of identical designation.
- Parts marked by "●" are not always kept in stock. Their delivery time may be longer than usual or they may be unavailable.

Mark	No.	Description	Parts No.	Mark	No.	Description	Parts No.
	1	VOL KNOB	AAB1259		31	METAL BONNET	ANE1323
	2	BAND BUTTON	AAD2100		32	MAGNET PLATE	ANG1558
	3	FUNCTION BUTTON	AAD2102		33	TUNER ASSEMBLY	AWE1230
	4	POWER BUTTON	AAD2104		34	
	5	TIMER BUTTON	AAD2105		35	DUMPER ASSY	AXA1013
	6	INTERNAL PANEL	AAK2221		36	MAGNET	AXX1016
	7	INDICATOR LENS	AAK2222		37	SCREW	BBZ26P080FMC
	8	PANEL	AAK2223		38	NUT	NK90FUC
	9	SCREW	ABA-298		39	FOOT ASSY(ABS)	RXA1448
	10	SCREW (STEEL)	ABA1009	Δ	40	FUSE(FU1 T2.5A)	AEK-512
	11	SCREW (STEEL)	ABA1011	Δ	41	FUSE(FU2 T1A)	AEK-508
	12	SCREW	ABA1018	Δ	42	FUSE(FU4 T5A)	AEK-515
	13	SCREW (STEEL)	ABA1143	Δ	43	FUSE(FU5 T5A)	AEK-515
Δ	14	AC POWER CORD	ADG1019	Δ	44	FUSE(FU6 T1.6A)	AEK-510
	15	BINDER	AEC-826	Δ	45	FUSE(FU7 T1.6A)	AEK-510
Δ	16	STRAIN RELIEF	AEC-882		46	FUSE(FU8 T2A)	AEK-511
	17	PCB SUPPORT	AEC1010		47	FFC	ADD1102
	18	PCB SPACER	AEC1100	Δ	48	POWER TRANSFORMER (T1)	ATT1178
	19	NYLON RIVET	AEC1160	●	49	AF ASSEMBLY	AWZ3764
	20	SPACER	AEC1236	●	50	DISPLAY ASSEMBLY	AWZ3769
	21	BINDER	AEP-215	●	51	VOLUME ASSEMBLY	AWZ3771
	22	TERMINAL SCREW	AKE-031	●	52	FUSE ASSEMBLY	AWZ3975
Δ	23	AC SOCKET 1-P	AKP-508		53	SHIELD ASSY	AWZ4117
Δ	24	FUSE HOLDER	AKR-038				
	25	FRONT PANEL	AMB1899				
	26	PCB MOLD	AMR1525				
	27	LEG ASSY(S)	AMR1937				
	28	SEALING DOOR ASSY	AMR2338				
	29	CHASSIS	ANA1160				
	30	REAR PANEL	ANC1786				

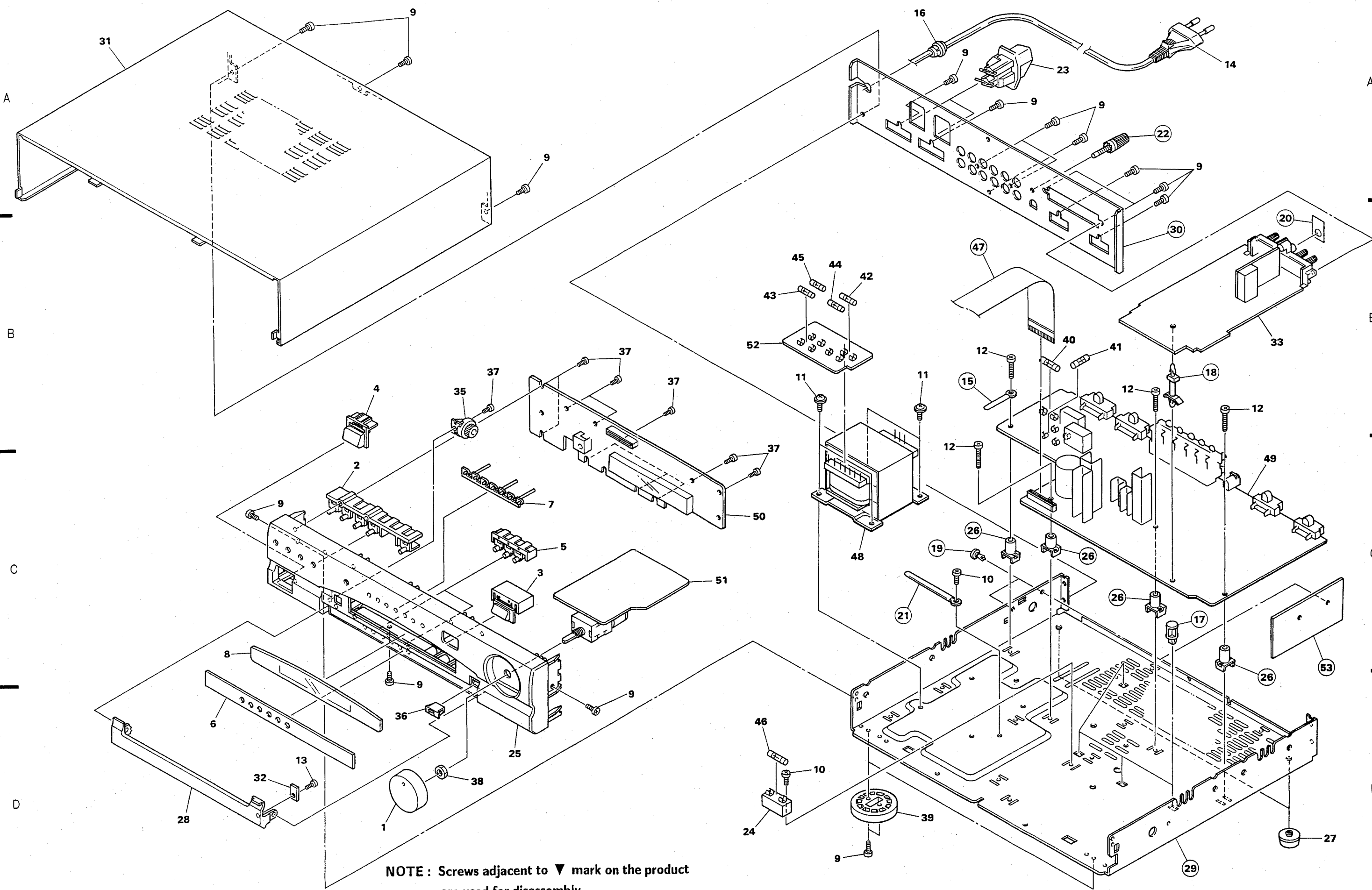

NOTE : Screws adjacent to ▼ mark on the product are used for disassembly.

2. PCB PARTS LIST

NOTES:

- Part without part number cannot be supplied.
Parts marked by "Ⓢ" are not always kept in stock. Their delivery time may be longer than usual or they may be unavailable.
The Δ mark found on some component parts indicates the importance of the safety factor of the part. Therefore, when replacing, be sure to use parts of identical designation.
When ordering resistors, first convert resistance values into code form as shown in the following examples.

Ex.1 When there are 2 effective digits (any digit apart from 0), such as 560 ohm and 47k ohm (tolerance is shown by J= 5%, and K= 10%).

Table showing resistor code examples: 560Ω, 47kΩ, 0.5Ω, 1Ω and their corresponding code forms like RD1/4PS561J, RD1/4PS473J, RD2H0R5K, RD1P010K.

Ex.2 When there are 3 effective digits (such as in high precision metal film resistors).

Table showing resistor code example: 5.62kΩ and its code form RD1/4SR5621F.

Table with 4 columns: Mark, No., Description, Parts No. for various components.

LIST OF ASSEMBLIES

Table listing assemblies: TUNER ASSEMBLY (AWE1230), AF ASSEMBLY (AWZ3764), DISPLAY ASSEMBLY (AWZ3769), VOLUME ASSEMBLY (AWZ3771), FUSE ASSEMBLY (AWZ3975).

TUNER ASSEMBLY(AWE1230)

SEMICONDUCTORS

Table listing semiconductor parts for the tuner assembly, including ICs (LM7001, LA1265S, AN7470P, Q901, Q902, Q903-904, Q905-907, Q908-909, Q910-913, Q914), Diodes (D901, D902, D903, D905), and Transistors (RN1203, RN2201, RN1203, 2SC2668, 2SC2458, 2SA1048, 1SV156, HSS104-02, 1SS85, HSS104-02).

COILS AND FILTERS

Table listing coils and filters: L901, L903, L904, L905, L907 (AXIAL INDUCTOR, COIL) and F903, F904, F905, F906 (CERAMIC FILTER).

CAPACITORS

Table listing various capacitor parts including C901-C943, C906-C911, C912-C916, C919-C925, C926-C930, C931-C938, C939-C943, with descriptions like CERAMIC CAPACITOR, AUDIO FILM CAPACITOR, ELECTROLYTIC CAPACITOR, and ELECTR. CAPACITOR.

Table with 4 columns: Mark, No., Description, Parts No. for various components.

Table listing capacitor parts: C944-C948, C949-C954, C955-C960, with descriptions like ELECTR. CAPACITOR, CERAMIC CAPACITOR, and ELECTROLYTIC CAPACIT.

RESISTORS

Table listing resistor parts: VR901, VR902, VR903, and Other Resistors with descriptions like VR(10kΩ), VR(22kΩ), VR(4.7kΩ).

OTHERS

Table listing other components: X901, X902, 2 SERIAL FE MODULE ASSY, AM RF TUNING BLOCK, ANTENNA TERMINAL (4P).

AF ASSEMBLY(AWZ3764)

SEMICONDUCTORS

Table listing semiconductor parts for AF assembly: IC101-102, IC103, IC104, IC105, IC106, IC201-206, IC207, IC301, Q101-104, Q105-107, Q108-109, Q112.

Table with 4 columns: Mark, No., Description, Parts No. for various components.

Table listing transistor and diode parts: Q113-Q205, Q301-Q399, D101-D102, D103-104, D105, D106, D109-111, D112-113, D114, D115-116, D202-203, D301, D307, D308, D399.

RELAYS

Table listing relays: RY101, RY102.

FILTERS

Table listing filters: L101, L301.

CAPACITORS

Table listing various capacitor parts including C101-C116, C117-C121, C122-C123, C217-218, C219-220, with descriptions like CKA, POLYESTER CAPACITOR, ELECTROLYTIC CAPACIT, and CERAMIC CAPACITOR.

Mark No.	Description	Parts No.
C225,226	ELECTR.CAPACITOR	CEAS470M10
C231,232	CERAMIC CAPACITOR	CKPUYB101K50
C235	CERAMIC CAPACITOR	CKDYB562K50
C236	CERAMIC CAPACITOR	CKCYB562K50
C237,238	CERAMIC CAPACITOR	CKCYB152K50
C239,240	ELECTR.CAPACITOR	CEAS3R3M50
C241,242	ELECTR.CAPACITOR	CEAS470M10
C243,244	ELECTR.CAPACITOR	CEAS100M25
C249,250	ELECTR.CAPACITOR	CEAS100M25
C257	CERAMIC CAPACITOR	CKCYX103M25
C301	CERAMIC CAPACITOR	CKCYX473M25
C302	CERAMIC CAPACITOR	CKCYF473Z50
C303	ELECTR.CAPACITOR	CEAS470M16
C304	CERAMIC CAPACITOR	CKCYX473M25
C305	ELECTR.CAPACITOR	CEAS010M50
C306	CERAMIC CAPACITOR	CKCYB102K50
C307	CERAMIC CAPACITOR	CKDYB102K50

RESISTORS

R102	METAL OXIDE RESISTOR	RS1LMF102J
R104	METAL OXIDE RESISTOR	RS1LMF102J
R106	METAL OXIDE RESISTOR	RS1LMF562J
R107	FUSIBLE RESISTOR	RFA1/4PL4R7J
R116	METAL OXIDE RESISTOR	RS3LMF151J
R117	METAL OXIDE RESISTOR	RS3LMF181J
R119,120	CARBON FILM RESISTOR	RD1/4PMF470J
R121-124	CARBON FILM RESISTOR	RD1/4PM100J
R127	METAL OXIDE RESISTOR	RS1LMF180J
R245,246	CARBON FILM RESISTOR	RD1/4PM820J
R305	RESISTOR ARRAY (56k Ω)	RA5T563J
R312	RESISTOR ARRAY (56k Ω)	RA5T563J
R345	RESISTOR ARRAY (56k Ω)	RA5T563J
Other Resistors		RD1/8PM□□□J

OTHERS

X301	CERAMIC RESO. (4MHz)	ASS1025
CN2	CONNECTOR(15P)	KPE15
CN3	CONNECTOR(13P)	KPE13
CN5	SOCKET(27P)	AKP1099
CN6	SOCKET(10P)	AKP1073
CN7	SOCKET(9P)	AKP1072
JACK		AKN-203
PIN JACK(6P)		AKB1121
PIN JACK(6P)		AKB1129
SCREW		BBZ30P080FZK
SOCKET(15P)		AKP1049

●DISPLAY ASSEMBLY(AWZ3769)

SEMICONDUCTORS

IC701	LOGIC IC	SN74LS42N
IC702	CONTROL MCU	PDG075A
Q701	TRANSISTOR	XDC143ES
Q702	TRANSISTOR	2SC2458
D701	DIODE	1SS252
D702-708	LED(RED)	AEL1108
D709-711	DIODE	1SS252
D712	ZENER DIODE	RD6.2ESB

Mark No.	Description	Parts No.
D713-721	DIODE	1SS252

SWITCHES

S701-716	SWITCH	ASG1034
SURROUND MODE, FUNC, STATION MEMORY, LOCAL/DX, SET, WAKE UP, REC, CLOCK ADJ, AUDITION, CENTER MODE, DELAY TIME, POWER, BAND, FREQ/ST, DOWN, UP		

FILTER

L701	AXIAL INDUCTOR	LAU220K
------	----------------	---------

CAPACITORS

C702	ELECTROLYTIC CAPACIT	CEJA4R7M35
C703	CERAMIC CAPACITOR	CKCYF223Z50
C704	CERAMIC CAPACITOR	CKPUYF473Z16
C705	ELECTR.CAPACITOR	CEJA010M50
C706	ELECTR.CAPACITOR	CEAS2R2M50
C707	CERAMIC CAPACITOR	CKCYB102K50
C708	ELECTR.CAPACITOR	CEJA470M10
C709	CERAMIC CAPACITOR	CKCYX473M25
C710	CEA (47000/5.5V)	ACH1037
C711	ELECTR.CAPACITOR	CEJA470M10
C712	ELECTR.CAPACITOR	CEAS4R7M50
C713	CERAMIC CAPACITOR	CKPUYF473Z16
C715	ELECTR.CAPACITOR	CEAS471M10
C716	CERAMIC CAPACITOR	CKDYB472K50

RESISTORS

R734	RESISTOR ARRAY (47k Ω)	RA8S473J
R745	RESISTOR ARRAY (47k Ω)	RA8S473J
R746	RESISTOR ARRAY (47k Ω)	RA11S473J
Other Resistors		RD1/8PM□□□J

OTHERS

V701	FL TUBE	AAV1138
X702	CRYSTAL RESO. (8MHz)	ASS1015
CN4	SOCKET(27P)	AKP1099
	REMOTE RECEIVER UNIT	AXX1010

●VOLUME ASSEMBLY(AWZ3771)

SEMICONDUCTORS

IC1601	MECHANISM DRIVER IC	TA7291S
IC1602	IC	UPC4570C
Q1601,1602	TRANSISTOR	2SC2878
Q1605	TRANSISTOR	RN2203

FILTER

L1601	AXIAL INDUCTOR	LAU221K
-------	----------------	---------

CAPACITORS

C1601-1604	ELECTR.CAPACITOR	CEAS2R2M50
C1605,1606	ELECTR.CAPACITOR	CEAS100M25
C1607,1608	ELECTR.CAPACITOR	CEAS101M16
C1609,1610	CERAMIC CAPACITOR	CKCYX104M25
C1627	CERAMIC CAPACITOR	CKCYX473M25
C1629,1630	CERAMIC CAPACITOR	CKCYB331K50
C1631	ELECTR.CAPACITOR	CEAS101M16

Mark No.	Description	Parts No.
----------	-------------	-----------

RESISTORS

VR1601	VARIABLE RESISTOR	ACX1064
R1613,1614	CARBON FILM RESISTOR	RD1/4PM121J
Other Resistors		RD1/8PM□□□J

● FUSE ASSEMBLY(AWZ3975)

FUSE assembly has no service part.

3. PANEL FACILITIES

REAR PANEL FACILITIES

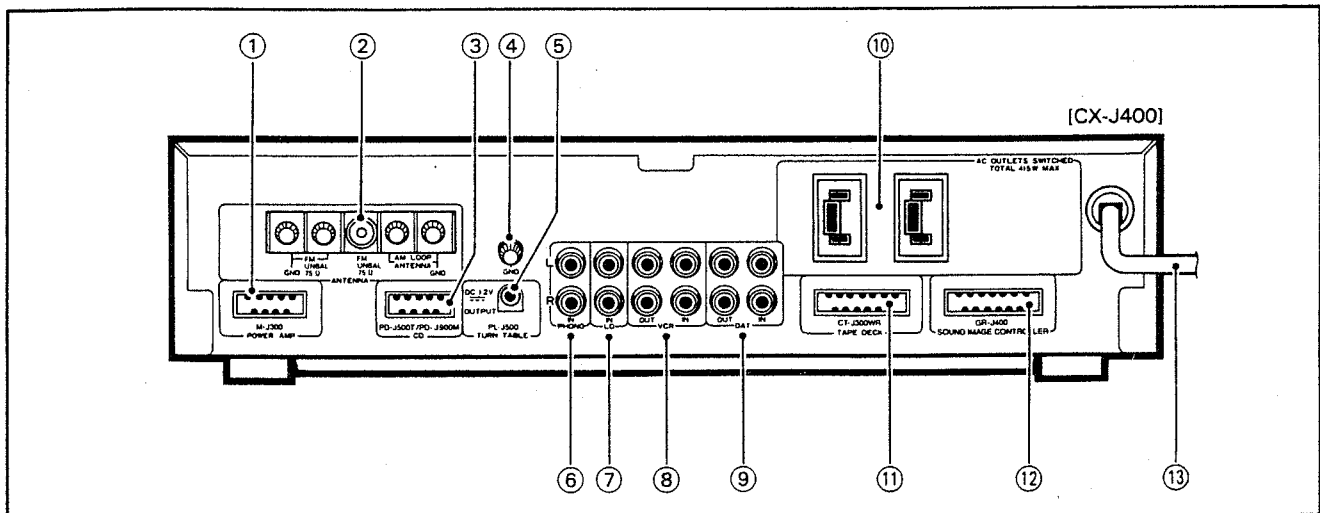

① POWER AMP jack

Connect the power amplifier (M-J200/M-J300) system cable here.

② FM/AM ANTENNA terminals

Antennas must be connected to these terminals; otherwise you will not be able to receive stations. See page 11 for details on ANTENNA CONNECTIONS.

③ CD jack

Connect the compact disc player (PD-J400T/PD-J500T/PD-J800M/PD-J900M) system cable here.

④ Ground terminal (GND)

Connect this to the ground terminal on the turntable (except for PL-J400/PL-J500).

⑤ TURNTABLE (DC 12V OUTPUT) jack

This jack supplies power to the turntable PL-J400/PL-J500.

⑥ PHONO input jacks

Connect the audio output cord of the turntable to these jacks.

⑦ LD input jacks

Connect to the output jacks of the LD player.

⑧ VCR jacks

IN : Connect to the audio output jacks of VCR.
OUT : Connect to the audio input jacks of VCR.

⑨ DAT jacks

IN : Connect to the analog audio output jacks of the digital audio tape deck.
OUT : Connect to the analog audio input jacks of the digital audio tape deck.

⑩ AC OUTLETS (SWITCHED TOTAL 415 W MAX)

Power supplied through this outlet is turned on and off by the tuner control amplifier's POWER switch. Total electrical power consumption of connected equipment should not exceed 415 W.
PD-J400T/PD-J500T or PD-J800M/PD-J900M CD player power cords, and the M-J200/M-J300 power amplifier cords can be connected.

NOTE:

Do not connect appliances with high power consumption such as heaters, irons, or television sets to the AC OUTLETS in order to avoid overheating or fire risk.

This can cause the tuner control amplifier to malfunction.

CAUTION:

DO NOT CONNECT TV SET OR MONITOR.

⑪ TAPE DECK jack

Connect the cassette deck system cable here.

⑫ SOUND IMAGE CONTROLLER jack

Connect the sound image controller system cable here.

⑬ Power cord

Connect this to the AC wall socket.

FRONT PANEL FACILITIES

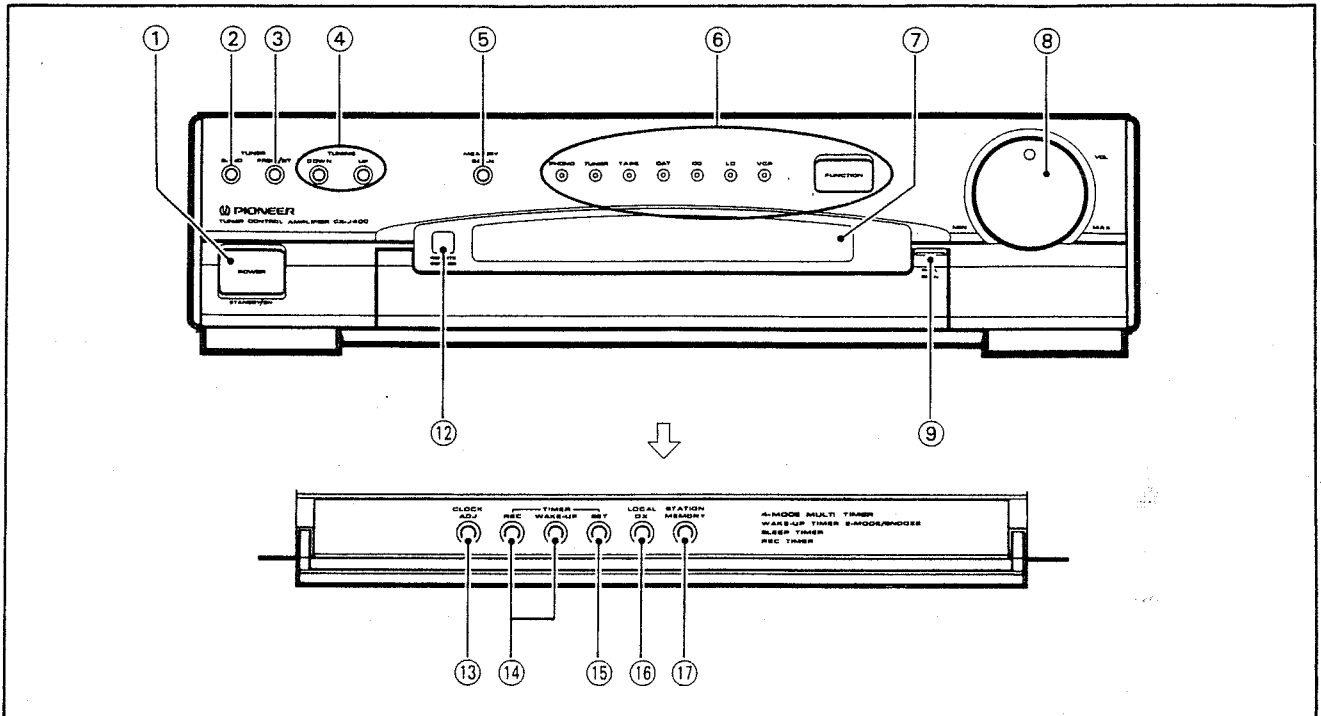

① POWER STANDBY/ON switch

This is the switch for electric power.

ON When set to the ON position, power is supplied and the unit becomes operational.

STANDBY .. When set to the STANDBY position, the main power flow is cut and the unit is no longer fully operational. A minute flow of power feeds the unit to maintain operation readiness.

- When only the time is indicated in the display section, the unit is in STANDBY.

② BAND selector button

Each time this button is pressed, FM, MW or LW (U.K. and European models only) reception is selected in order.

③ FREQ/ST (Frequency/Station) button

Press to switch between frequency and station modes.

④ TUNING (UP, DOWN) buttons

[During tuning]

- When in the Frequency mode, use to raise and lower the reception frequency.

- When in the Station mode, use to raise and lower the station number.

[During time and timer setting]

Used for adjusting the clock, timer settings and its related adjustments.

⑤ MEMORY SCAN button

Press this button to scan programs on the preset stations automatically for 7 seconds each. If you wish to continue listening to the station currently being scanned, press this button again to lock the tuning to the station. This will cancel the preset scan function and return you to normal reception.

⑥ FUNCTION button/indicators

Each time you press the FUNCTION button, the tuner control amplifier function changes. The selected function's indicator lights.

[PHONO]

Select to play records on a turntable connected to the PHONO input jacks.

[TUNER]

Select to listen to radio broadcast.

[TAPE]

Select to listen to cassette tape.

[DAT]

Select to listen a DAT playing on a digital audio tape deck connected to the DAT jacks.

[CD]

Select to listen to compact disc.

[LD]

Select to play an LD on a video disc player connected to the LD input jacks.

[VCR]

Select to play a tape on a video cassette recorder connected to the VCR jacks.

⑦ Display section

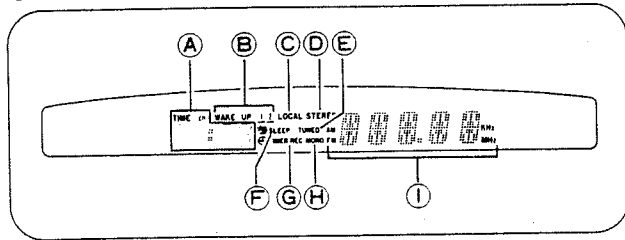

① Time/channel indicator

Normally indicates the current time. The current time is shown when the display is in the frequency mode; the channel number is shown when the display is in the station mode.

② WAKE UP timer indicator

Displays the selected wake up timer.

③ LOCAL indicator

Lights when the LOCAL/DX button ⑮ is set to ON.

④ STEREO indicator

Lights when an FM stereo broadcast is received (FM MONO button on the remote control unit set to OFF).

⑤ TUNED indicator

Lights when a broadcast is received and tuned in well.

⑥ SLEEP indicator

Indicates that the sleep timer is activated.

⑦ REC timer indicator

Displays the timer's setting condition.

⑧ MONO indicator

Lights when the FM MONO button on the remote control unit is set to ON. When this indicator is lit, FM stereo broadcasts are reproduced monaurally.

① Frequency display

Shows received broadcast frequency. Also gives scrolling display of main function status.

FM and MHz light: FM reception.

AM and kHz light: MW or LW (U.K. and European models only) reception.

⑧ VOL (volume) control

⑨ Open this with your finger.

⑫ Remote sensor window

⑬ CLOCK ADJ button

Used for starting the clock adjustment.

⑭ Timer selector buttons

[WAKE-UP 1, 2]

Used for timer playback setting.

[REC]

Used for timer recording setting.

⑮ SET button

Used for current time, timer playback, and timer recording setting.

⑯ LOCAL/DX button (when receiving FM broadcasts)

Use this if the broadcast signal is too strong, causing noise and distortion. The attenuator reduces the strength of the signal, reducing noise and distortion.

⑰ STATION MEMORY button

Used to memorizing stations.

4. SPECIFICATIONS

FM Tuner Section

Reception frequency range.....	87.5 MHz to 108.0 MHz
Usable Sensitivity	Mono: 12.8 dBf, IHF (1.2 μ V/75 Ω)
Sensitivity (DIN).....	MONO (S/N 26 dB: 1 μ V/75 Ω) STEREO (S/N 46 dB: 1 μ V/75 Ω)
Signal-to-Noise Ratio (IHF, 85 dBf input).....	Mono: 77 dB
Signal-to-Noise Ratio (DIN).....	Mono: 66 dB Stereo: 60 dB
Distortion	Stereo: 0.5 %, 1kHz
Antenna input	75 Ω unbalanced

AM (MW) Tuner Section

Frequency Range (For European and multi-voltage models)	531 kHz to 1,602 kHz
(For multi-voltage models)	530 kHz to 1,700 kHz
Sensitivity (IHF, Loop antenna)	350 μ V/m
Antenna	Loop antenna

LW Tuner Section

(For LW equipped models only)

Frequency range	153 kHz to 281 MHz
Sensitivity (IHF, Loop antenna).....	1,500 μ V/m
Antenna	Loop antenna

Electrical Section, Other

Power requirements

European models	AC 220 – 230 V, 50/60 Hz
U.K. models	AC 240 V, 50/60 Hz
Multi-voltage models	AC 110/120–127/220/240 V (switchable), 50/60 Hz

Power consumption

European models	40 W
Multi-voltage models	50 W

AC outlet

External dimensions

Weight

* Measured by Audio Spectrum Analyzer.

5. SCHEMATIC DIAGRAMS AND PCB CONNECTIONS DIAGRAMS

OVERALL WIRING DIAGRAM

1. RESISTORS :

Indicated in Ω , 1/4W, 1/6W and 1/8W, $\pm 5\%$ tolerance unless otherwise noted k; k Ω , M; M Ω , (F); $\pm 1\%$. (G); $\pm 2\%$. (K); $\pm 10\%$. (M); $\pm 20\%$ tolerance.

2. CAPACITORS :

Indicated in capacity (μ F)/voltage(V) unless otherwise noted p; pF. Indication without voltage is 50V except electrolytic capacitor.

3. VOLTAGE, CURRENT :

\square : DC voltage (V) at no input signal unless otherwise noted. Value in () is DC voltage at rated power.
 \leftarrow mA or \leftarrow mA : DC current at no input signal unless otherwise noted.

4. OTHERS :

\rightarrow : Signal route.
 \odot : Adjusting point
 ∇ (red) : Measuring point
 The Δ mark found on some component parts indicates the importance of the safety factor of the part. Therefore, when replacing, be sure to use parts of identical designation.
 * marked capacitors and resistors have parts numbers.

This is the basic schematic diagram, but the actual circuit may vary due to improvements in design.

5. SWITCHES : (The underlined indicates the switch position)

- DISPLAY ASSEMBLY
- S701 SURROUND MODE
 - S702 FUNC
 - S703 STATION MEMORY
 - S704 LOCAL/DX
 - S705 SET
 - S706 WAKE UP
 - S707 REC
 - S708 CLOCK ADJ.
 - S709 AUDITION
 - S710 CENTER MODE
 - S711 DELAY TIME
 - S712 POWER
 - S713 BAND
 - S714 FREQ/ST
 - S715 DOWN
 - S716 UP

A

B

C

D

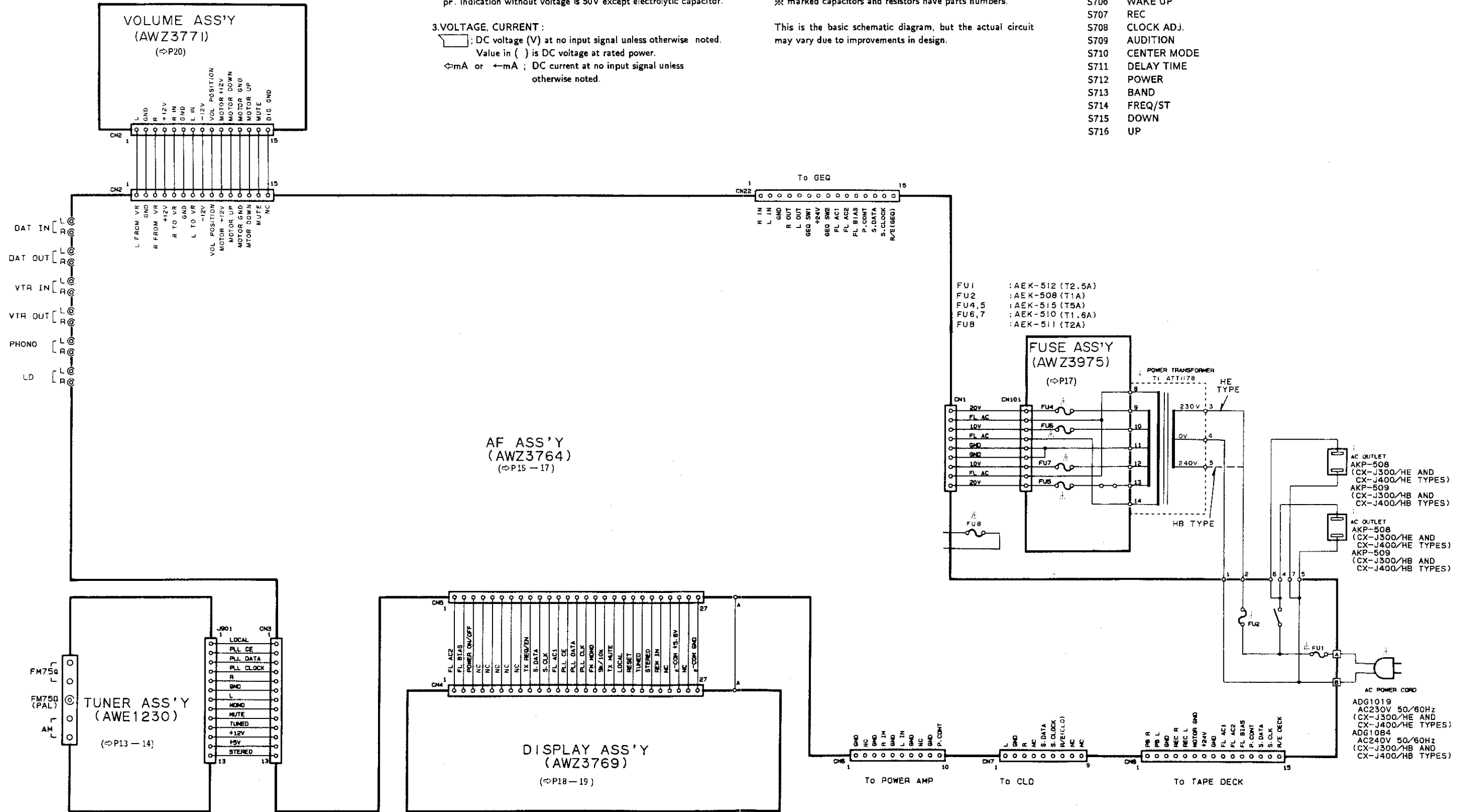

A

B

C

D

TUNER ASSY

IC903 AN7470P

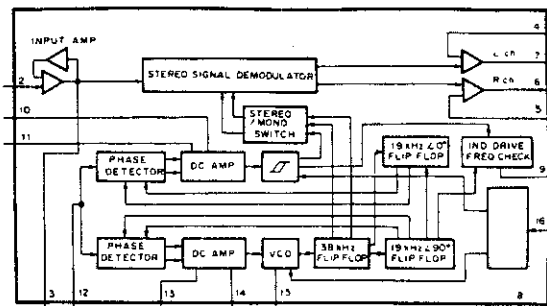

IC903 AN7470P

Pin No.	Voltage	Pin No.	Voltage	Pin No.	Voltage
1	11.2	9	4.9	15	3.2
2	2.6		0.6	16	0
3	6.1		(STEREO)		11.4
4	8.9	10	2.6		4.0
5	8.9	11	2.6		(MONO)
6	3.9	12	2.6		
7	3.9	13	2.6		
8	0	14	2.6		

IC902 LA1265S

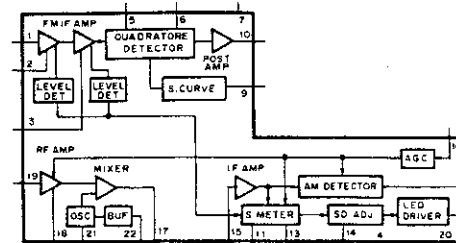

IC902 LA1265S

Pin No.	Voltage	Pin No.	Voltage	Pin No.	Voltage
1	2.3	10	2.8	17	0
2	2.3	11	1.5		12.0(AM)
3	2.3	12	1.5	18	0
4	0	13	1.4(MAX)		2.0(AM)
5	12.0	14	1.4(MAX)	19	0
6	12.0		0(AM)		2.0(AM)
7	12.0	15	2.3	20	3.8
8	0(T)		1.1(AM)	21	3.8
	5.1(D)	16	1.4	22	2.8
9	3.8				1.5(AM)

NOTE: (T): TUNE IND. ON; (D): TUNE IND. OFF.

IC901 LM7001

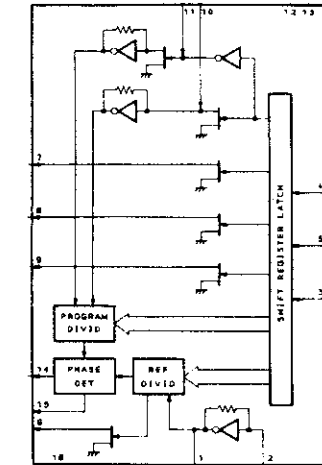

IC901 LM7001

Pin No.	Voltage	Pin No.	Voltage
1	1.1	9	0.46
2	1.5	10	0
3	0	11	1.7(AM)
4	0	12	5.0
5	0	13	5.0
6	GND	14	0.7
7	—	15	—
8	0	16	0

TUNER ASS'Y (AWE1230)

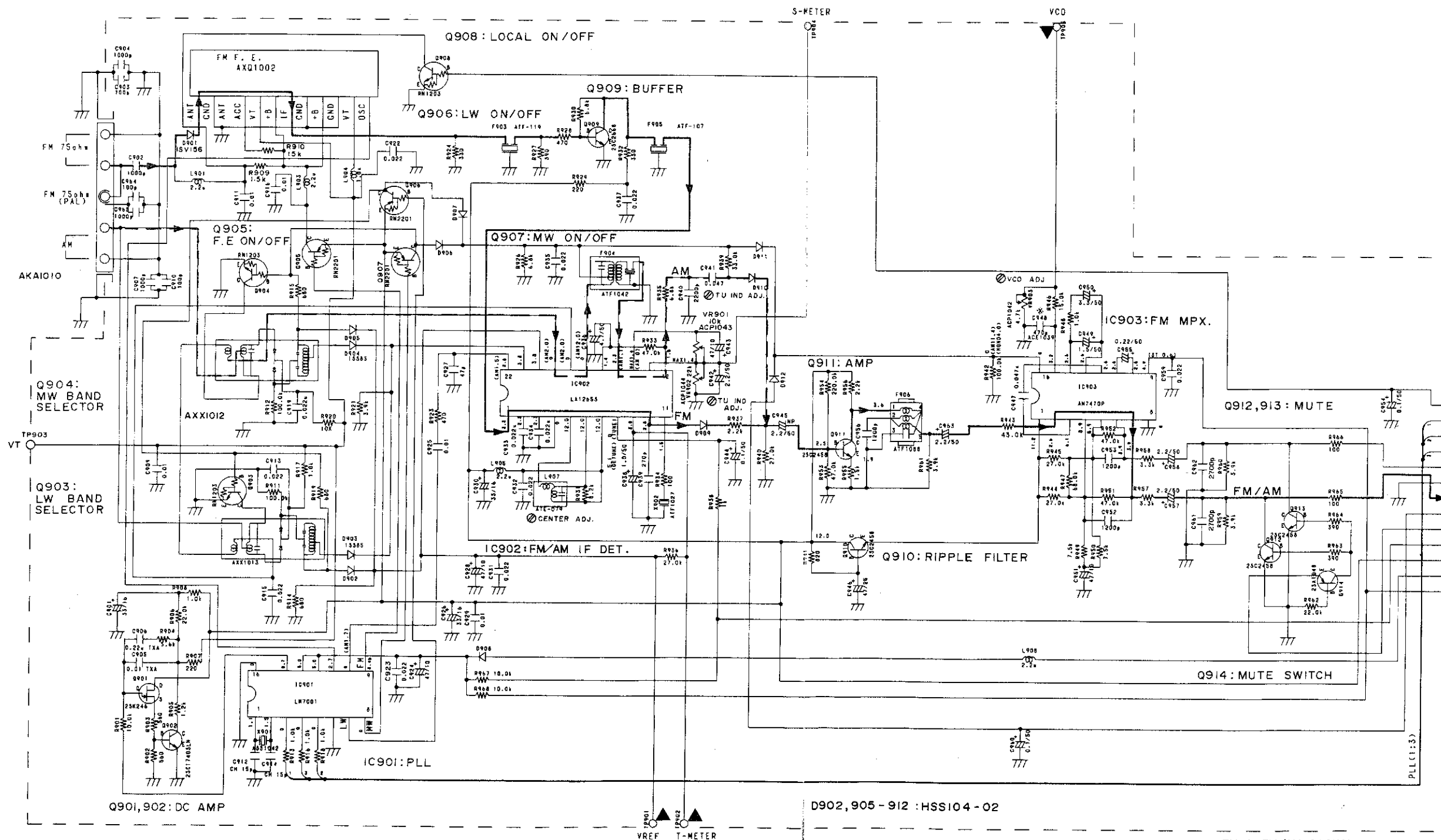

- LOCAL
- PLL CE
- PLL DA
- PLL CL
- Rch
- GND
- Lch
- MONO
- MUTE
- TUNE
- +12V
- +5.6V
- STEREO

— : FM & FM/AM SIGNAL
 - - - : AM SIGNAL

A

DISPLAY AND VOLUME ASSY

DISPLAY ASS'Y (AWZ3769)

B

C

D

E

F

TO AF ASS'Y CN5 (To page 17)

- u-cen GND
- NC
- u-cen S.5V
- NC
- REM IN
- STEREO
- TUNED
- RESET
- LOCAL
- TX MUTE
- 9K/10K
- FM MONO
- PLL CLK
- PLL DATA
- PLL CE
- FL AC 1
- S.CLK
- S.DATA
- TX REQ/EN
- NC
- NC
- NC
- NC
- POWER ON/OFF
- FL BIAS
- FL AC 2

IC701:LED DRIVER

FUNCTION SELECTION OF IC701

FUNCTION	A	B	C
TUNER	H	H	H
TAPE	L	H	H
CLD(CD)	H	L	H
VTR	M	H	L
DAT	L	H	L
TV(PHONO)	H	L	L
BS(LD)	L	L	L
STANDBY	L	L	H

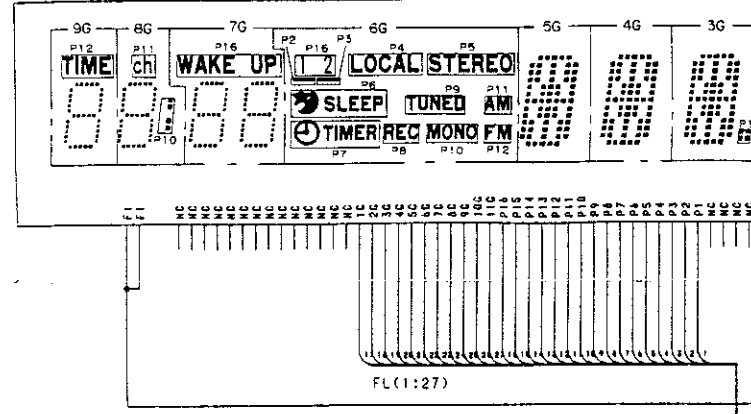

D702 - 708: AEL1108
D701, 709-711, 713-721: ISS252

Q702: 50/60Hz DETECT

Q701: RESET

IC702: TUNER CONTROL MPU

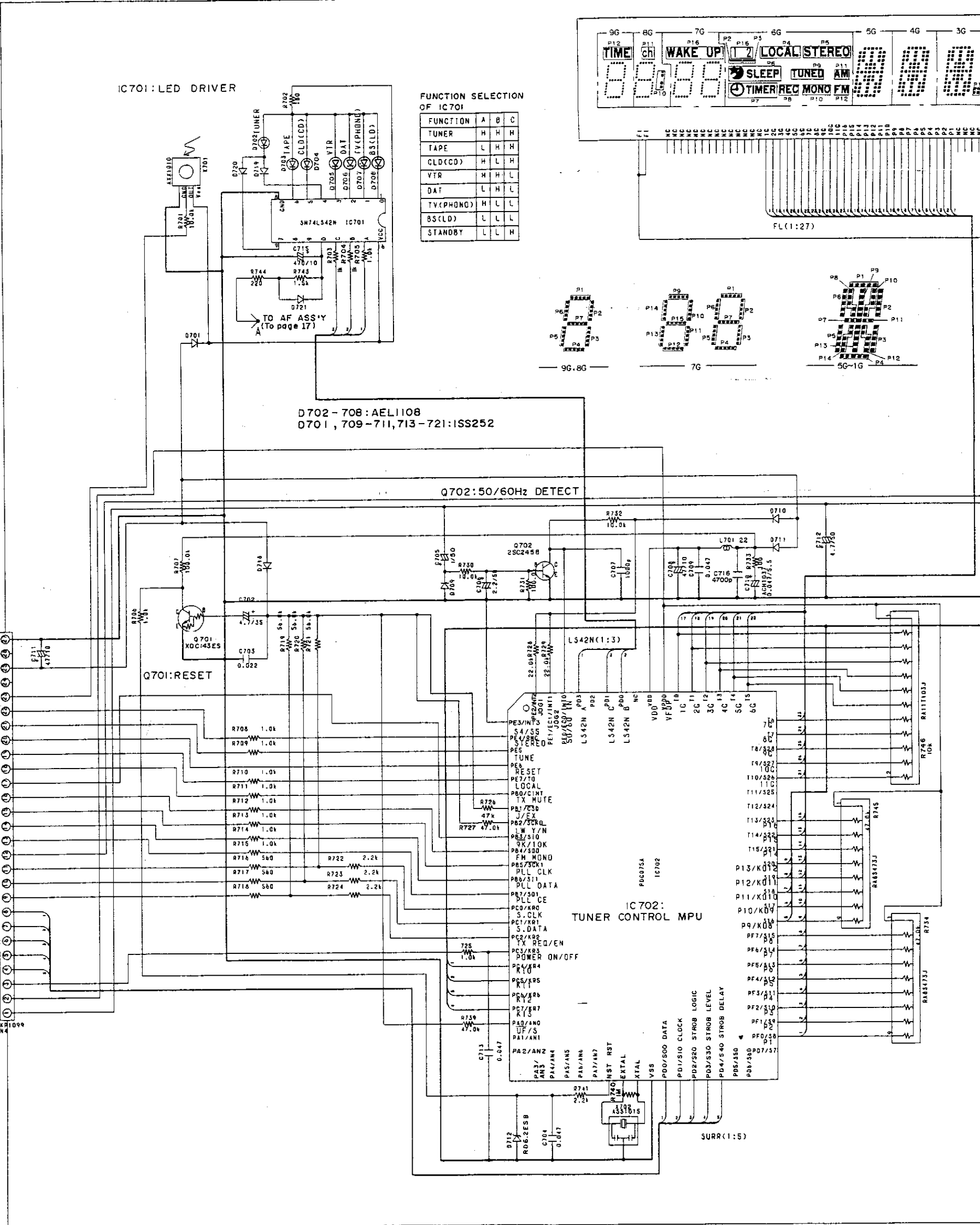

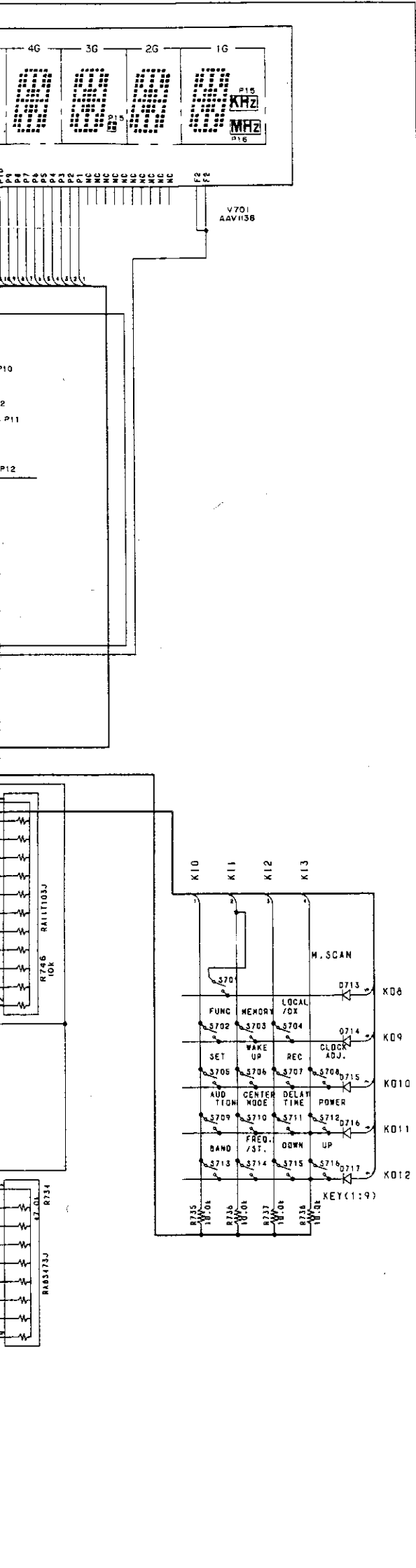

IC1601 TA7291S

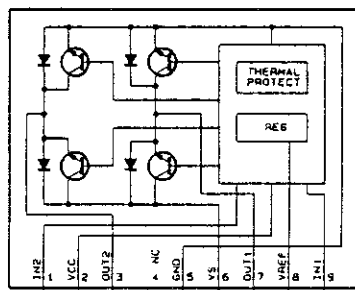

VOLUME ASS'Y (AWZ3771)

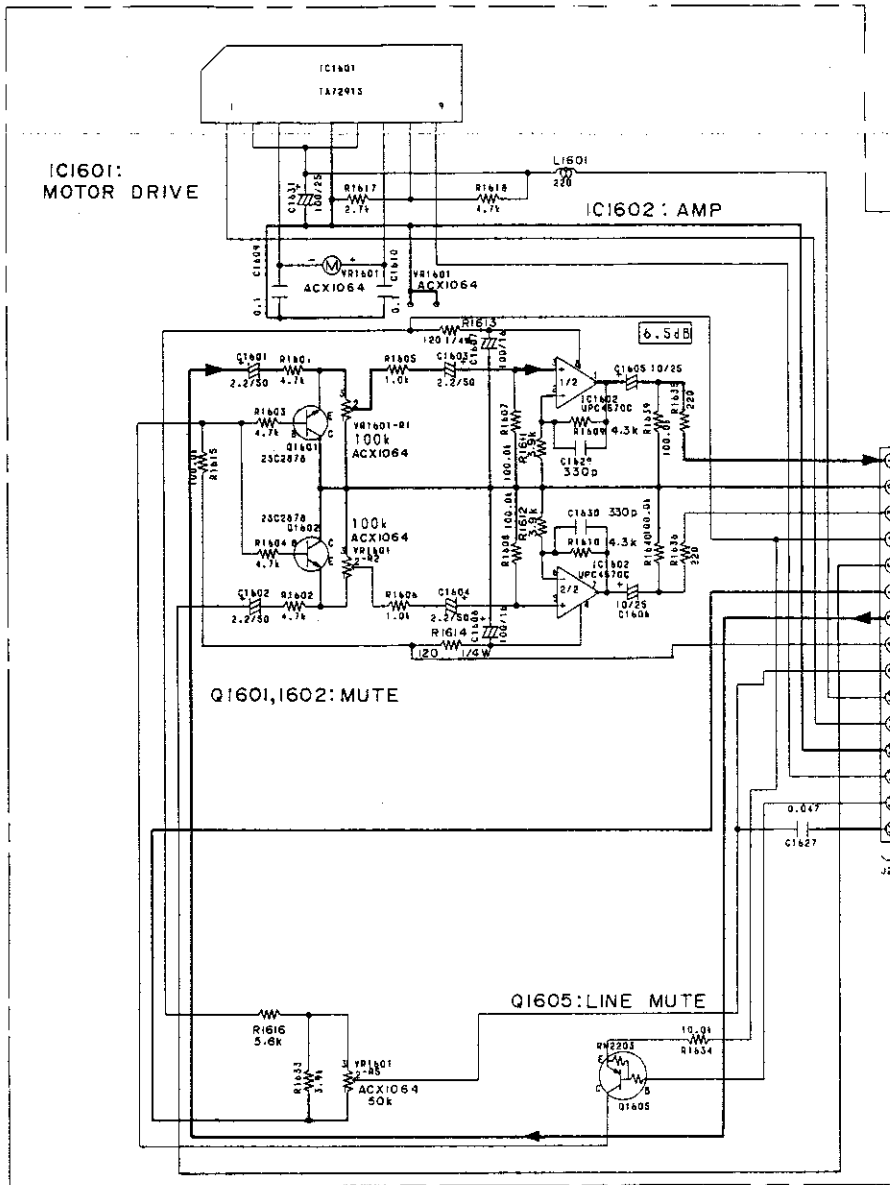

TO AF ASS'Y CN2 (To Page 17)

AF AND FUSE ASSY

AF ASS'Y
(AWZ3764)

FUNCTION SELECTION

	INH	A	B
PHONO	L	L	L
CLD	L	H	L
TUNER	L	L	H
TAPE	L	H	H
LD	H	L	H
VTR	H	H	H
DAT	H	L	L

A: Pin 6 of IC301
B: Pin 7 of IC301
INH: Pin 8 of IC301

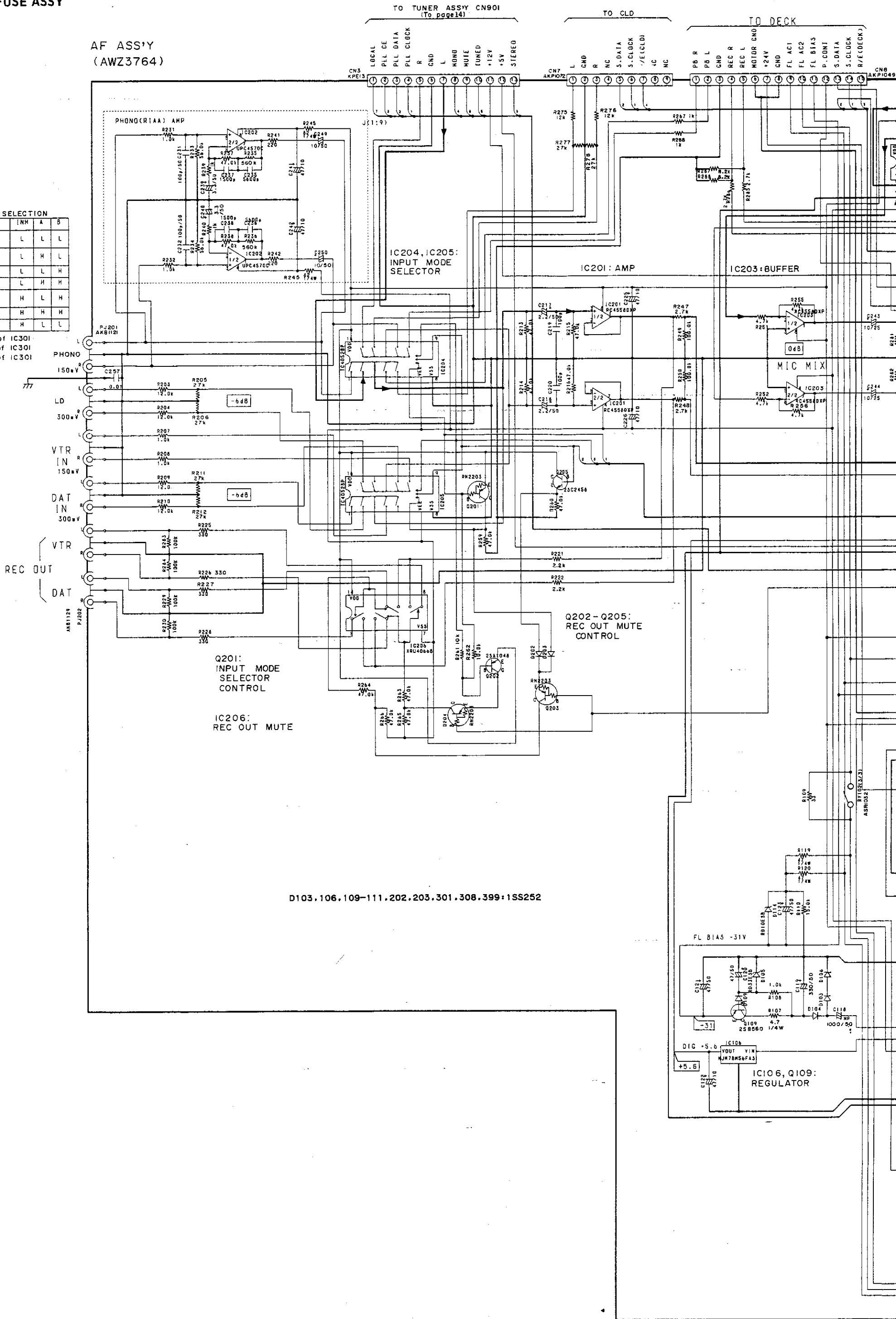

D103, 106, 109-111, 202, 203, 301, 308, 399: 1SS252

FL BIAS -31V

IC106, Q109:
REGULATOR

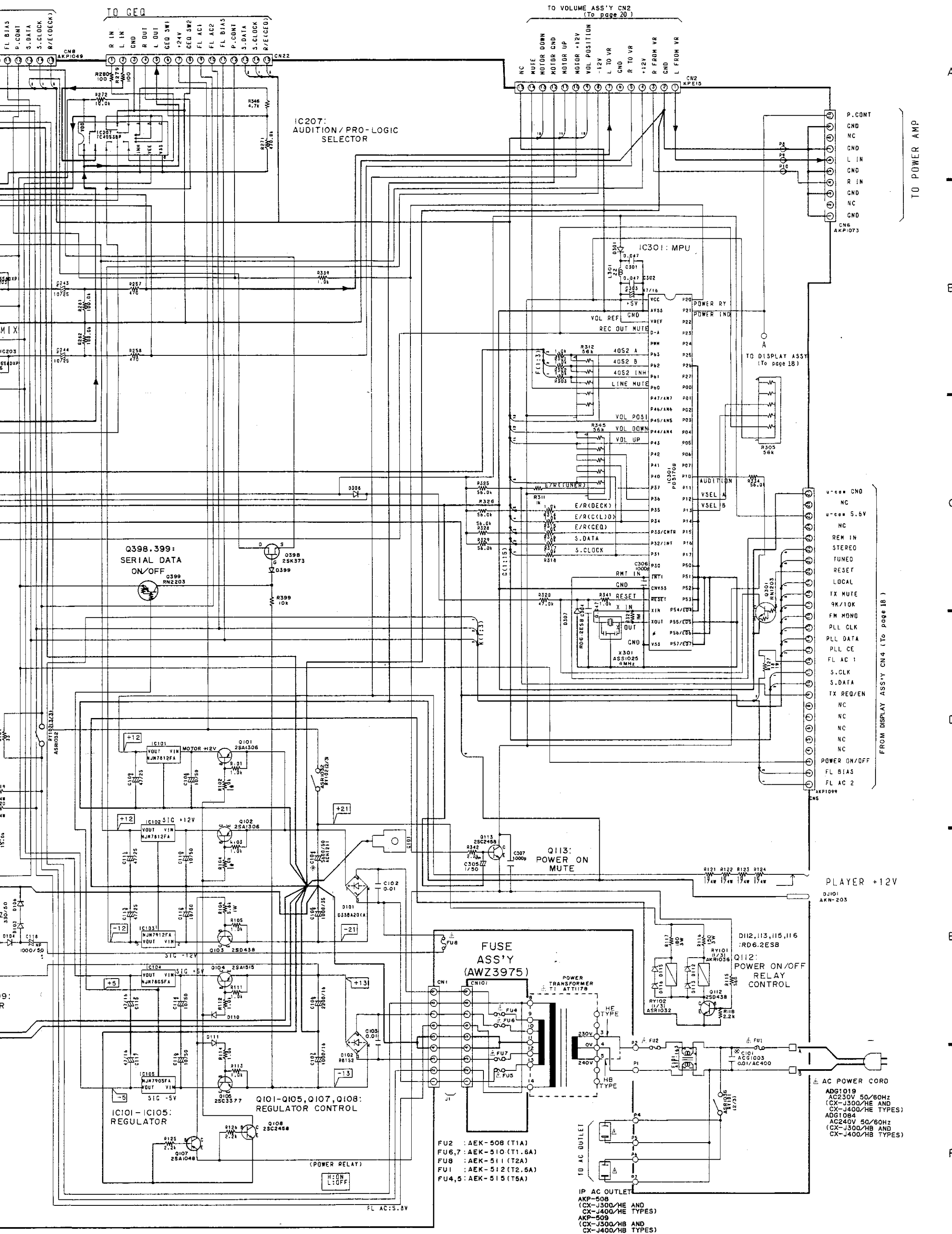

IC207: AUDITION / PRO-LOGIC SELECTOR

IC301: MPU

Q398, 399: SERIAL DATA ON/OFF

Q113: POWER ON MUTE

FUSE ASS'Y (AWZ3975)

Q112: POWER ON/OFF RELAY CONTROL

Q101-Q105, Q107, Q108: REGULATOR CONTROL

IC101-IC105: REGULATOR

- FU2 : AEK-508 (T1A)
- FU6,7 : AEK-510 (T1.6A)
- FU8 : AEK-511 (T2A)
- FU1 : AEK-512 (T2.5A)
- FU4,5 : AEK-515 (T5A)

- ADG1019 AC230V 50/60Hz (CX-J300/HE AND CX-J400/HE TYPES)
- ADG1084 AC240V 50/60Hz (CX-J300/HE AND CX-J400/HE TYPES)

IP AC OUTLET
 AKP-508 (CX-J300/HE AND CX-J400/HE TYPES)
 AKP-509 (CX-J300/HE AND CX-J400/HE TYPES)

TO POWER AMP

FROM DISPLAY ASS'Y CN4 (To page 18)

PLAYER +12V

A

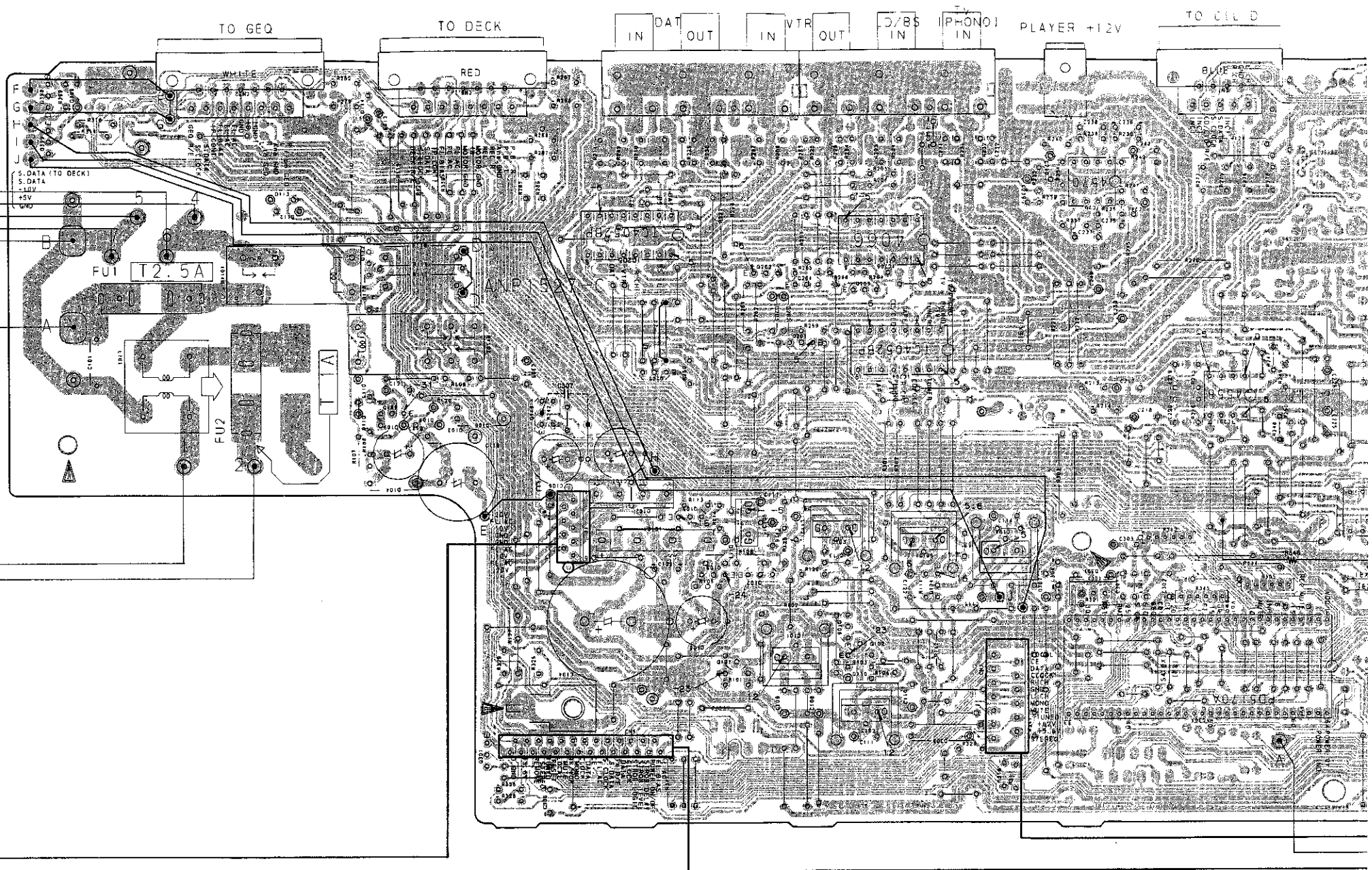
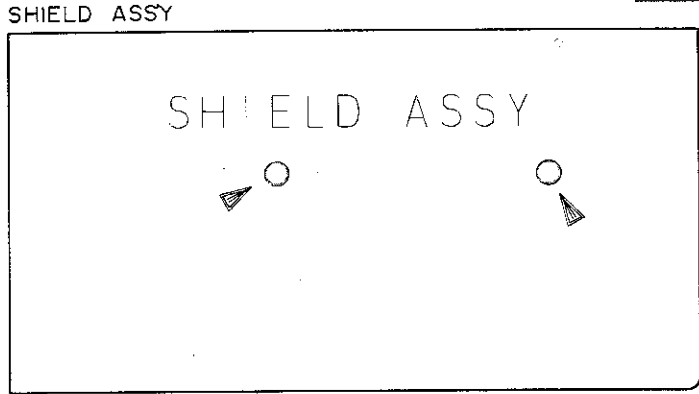
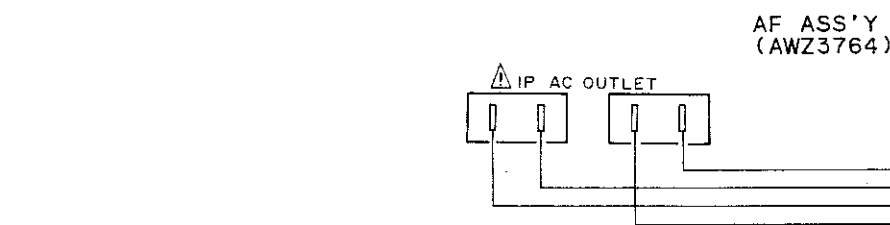

B

C

FUSE ASSY (AWZ3975)

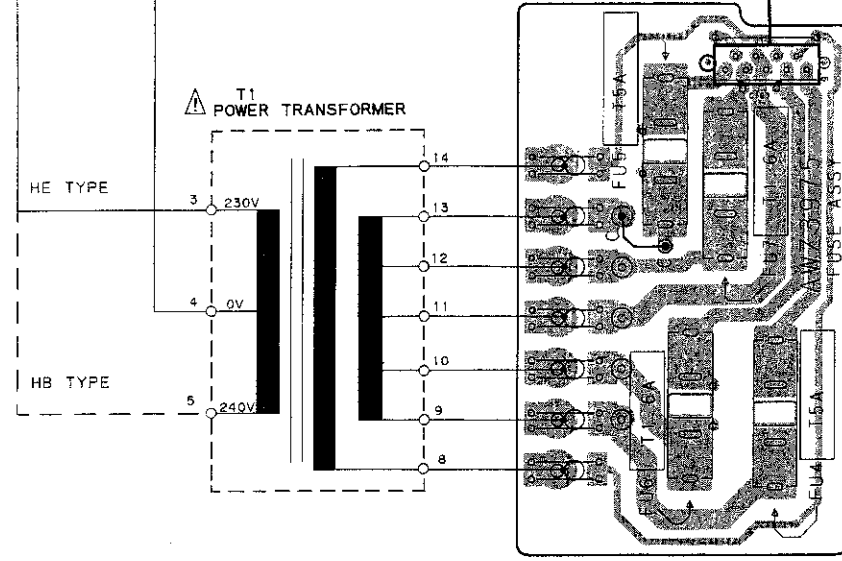

Q398	Q112	Q301	Q113	IC205	Q105	Q202	Q204	IC206	IC104	IC202	IC301	IC201	IC2
Q399	Q102			Q205	Q103	IC105	Q201	Q203	IC204				
					Q101	Q107	IC103	IC106					
							IC101	Q108	Q104				
								Q102					
								IC102					

Line Voltage Selection (HE and HB TYPES)

Line voltage can be changed with the following steps.

1. Disconnect the AC power cord.
2. Remove the top cover.
3. Change the connection of the power transformer lead wire.
4. Stick the line voltage label on the rear panel.

Part No.	Description	
AXX-193	220V label	----- 220V-230V
AXX-192	240V label	————— 240V

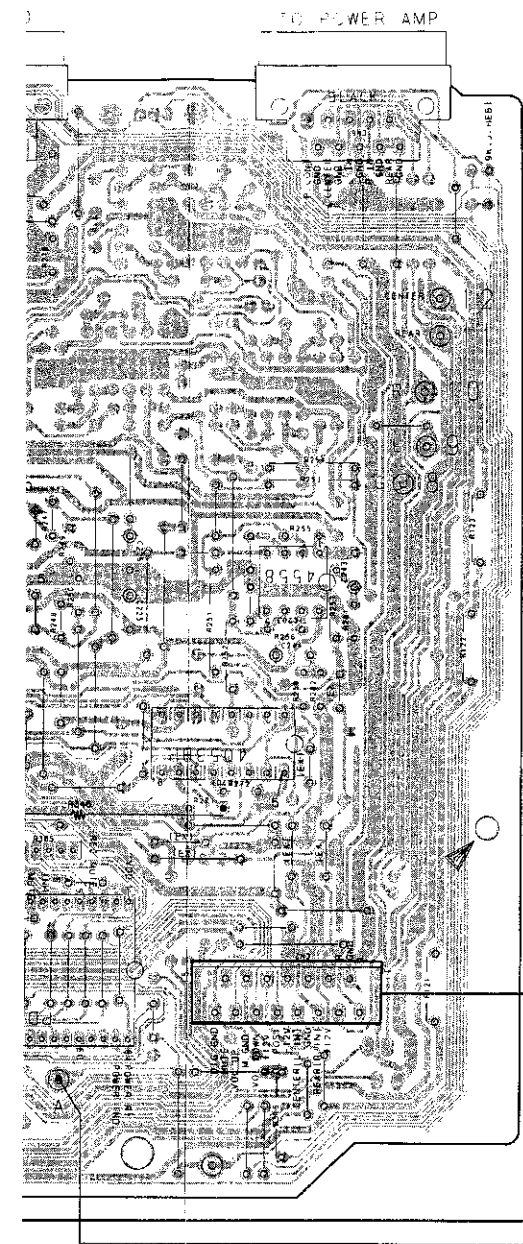

VOLUME ASS'Y(AWZ3771)

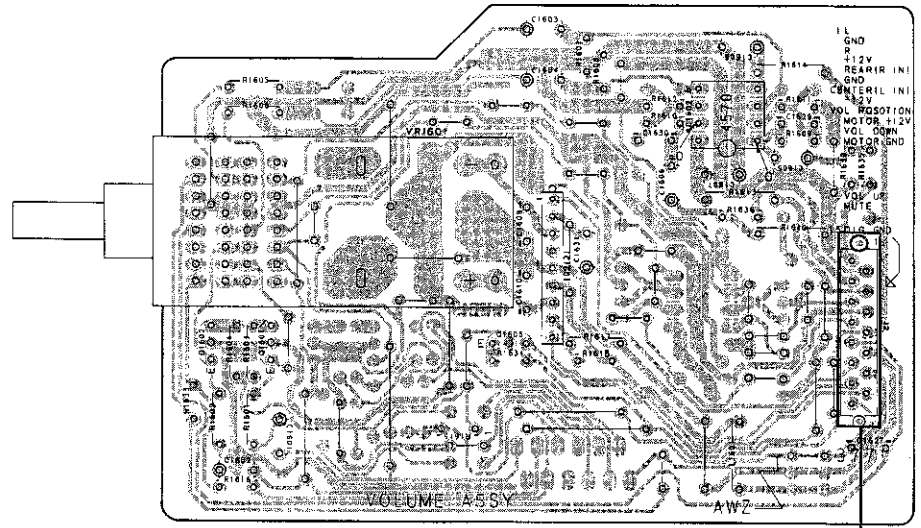

VR1601
Q1602 Q1601 Q1605 IC1601 IC1602

TUNER ASS'Y(AWE1230)

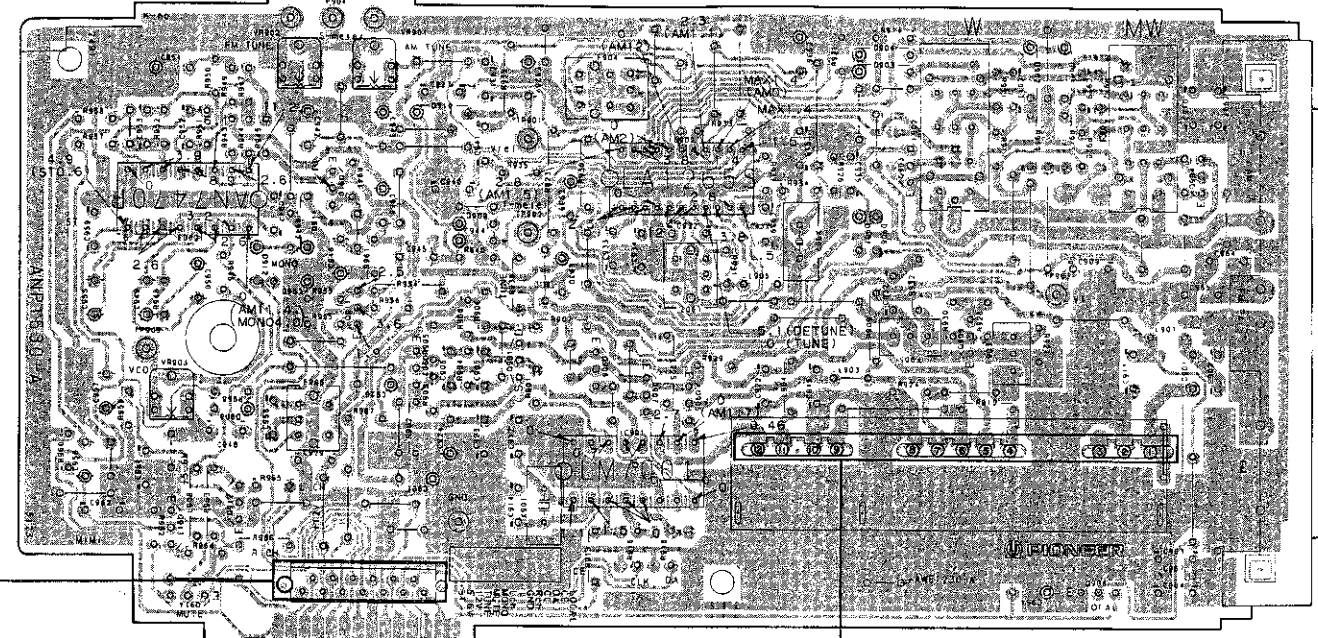

VR903 VR902 VR901
IC903 Q910 Q902 Q901 Q906 Q907 Q905 Q903 Q909 Q908 Q904
Q913 Q912 Q911 IC902
Q914 IC901

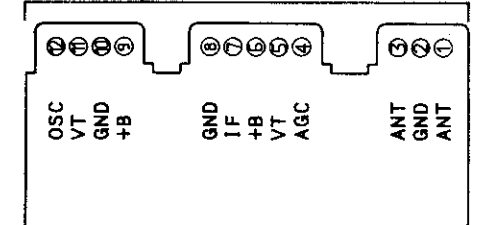

FE MODULE ASS'Y (AXQ1002)

- NOTE
1. This P.C.B connection diagram is viewed from the parts mounted side.
 2. The parts which have been mounted on the board can be replaced with those shown with the corresponding wiring symbols listed in the following Table.

P.C.B. pattern diagram indication	Corresponding part symbol	Part Name
		Transistor
		Radiator type transistor
		Diode
		Resistor
		Capacitor (Polarity)
		Capacitor (Non-polarity)

Others

P.C.B. pattern diagram indication	Part Name
IC	IC
S	Switch
RY	Relay
L	Coil
F	Filter
VR	Variable resistor or Semi-fixed resistor

3. The capacitor terminal marked with ⊖ (double circles) shows negative terminal.
4. The diode terminal marked with ⊕ (double circles) shows cathode side.
5. The transistor terminal to which E is affixed shows the emitter.

IC207 IC203

DISPLAY ASS'Y(AWZ3769)

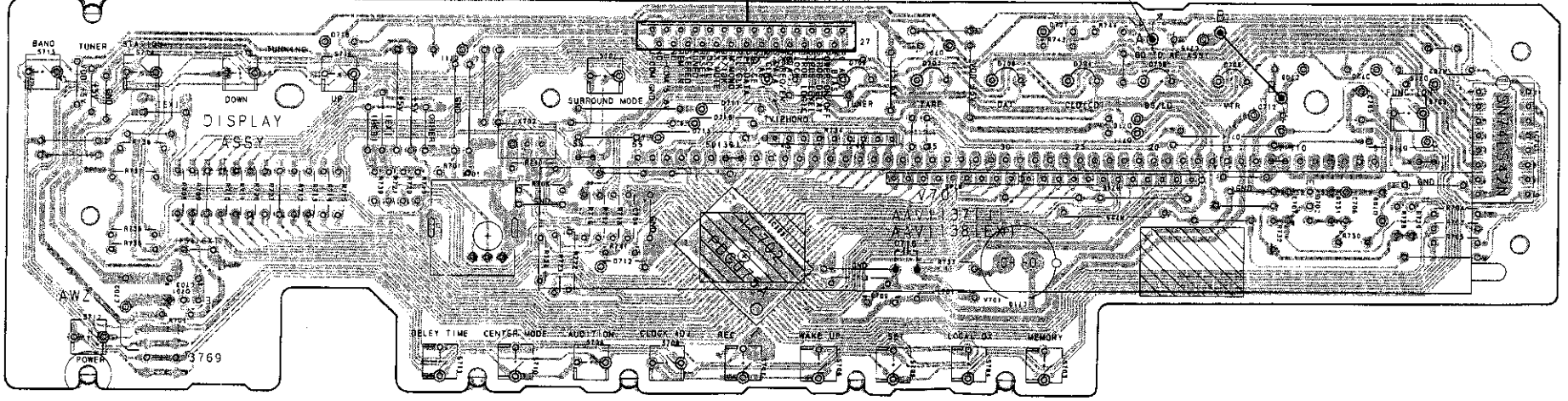

Q701 IC702 Q702 IC701

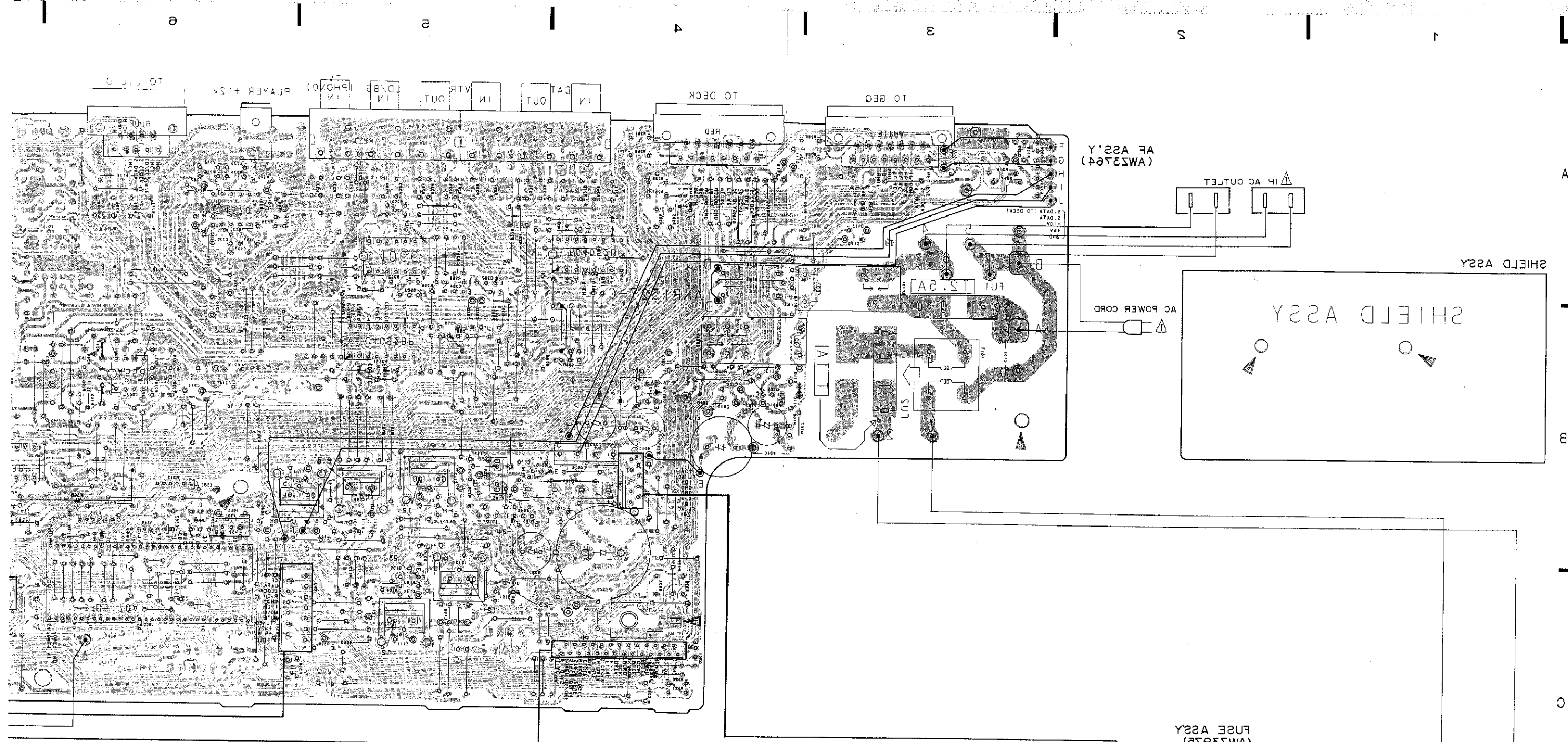

A
B
C
D

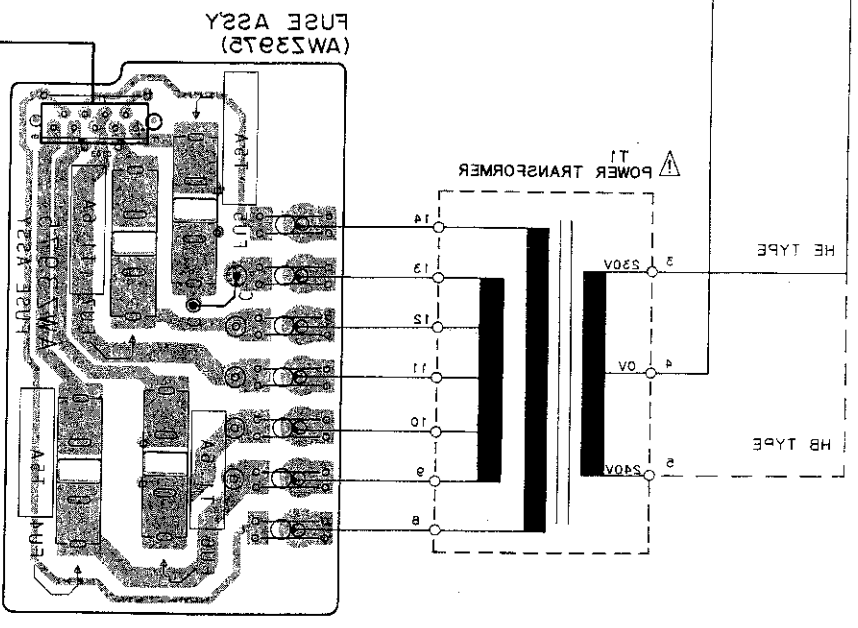

IC50
IC301 IC304 IC305 IC306
IC104 IC105 IC106 IC107 IC108 IC109 IC110 IC111 IC112 IC113 IC114 IC115 IC116 IC117 IC118 IC119 IC120 IC121 IC122 IC123 IC124 IC125 IC126 IC127 IC128 IC129 IC130 IC131 IC132 IC133 IC134 IC135 IC136 IC137 IC138 IC139 IC140 IC141 IC142 IC143 IC144 IC145 IC146 IC147 IC148 IC149 IC150

6. ADJUSTMENTS

- As to connections and points to be adjusted, refer to Fig. 6-1, Fig. 6-2 and Fig. 6-3.

6.1 AM TUNER ADJUSTMENT

- Set the BAND selector to "AM".

Step No.	Adjustment Title	AM SG(400Hz, 30% modulation)		Reception Frequency Display	Adjustment	
		Frequency(kHz)	Level(dB μ V/m)		Adjustment Location	Specifications
1	TUNED indicator sensitivity adjustment	999	55 \pm 5	999kHz	VR901	Adjust so that the indicator lights up.

6.2 FM TUNER ADJUSTMENT

- Set the BAND selector to "FM".
- Perform VCO adjustment two minutes or more after turning the power ON.

Note: Stereo modulation: Main 1 kHz L + R \pm 68.25 Hz dev.

Pilot 19 kHz \pm 6.75 kHz dev.

Step No.	Adjustment Title	FM SG(1kHz \pm 75kHz dev.)		Reception Frequency Display	Adjustment	
		Frequency(MHz)	Level(dB μ V)		Adjustment Location	Specifications
1	Detector coil T-meter adjustment	98.0	80	98.0MHz	L907	Adjust so that the DC voltage between TP901 and TP902 is \pm 50mV.
2	VCO adjustment	98.0 (No modulation)	80	98.0MHz	VR903	Adjust so that the frequency between TP905 and GND is 76 \pm 0.5kHz
3	TUNED indicator sensitivity adjustment	98.0	18 \pm 3	98.0MHz	VR902	Adjust so that the indicator lights up.

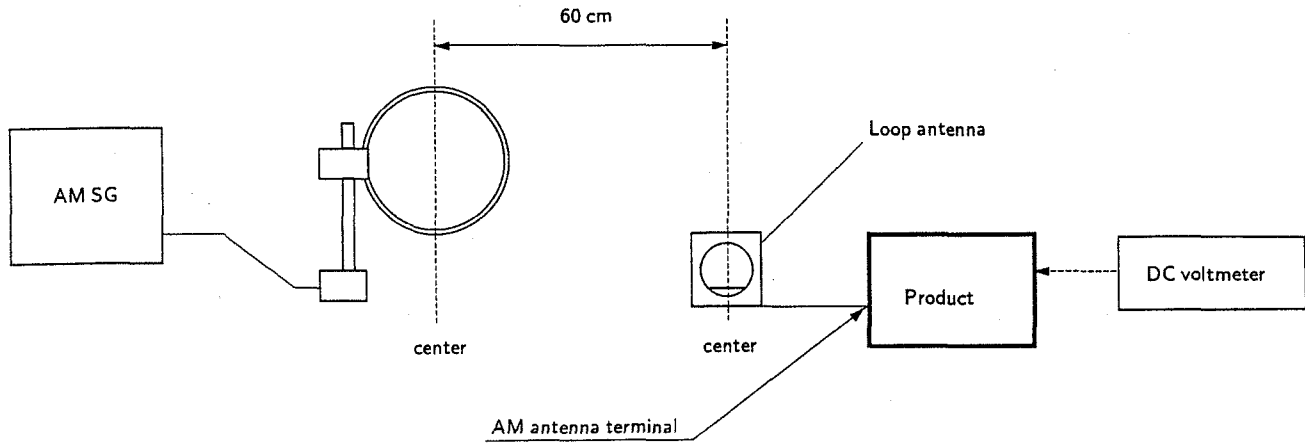

Fig. 6-1 AM Adjustment Connection Diagram

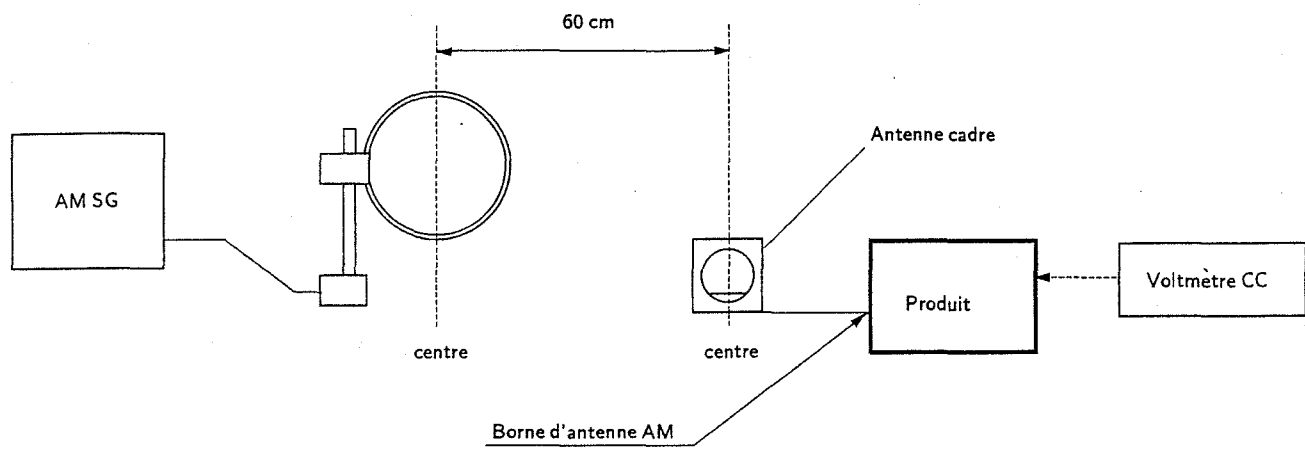

Fig. 6-1 Schéma de raccordement de réglage AM

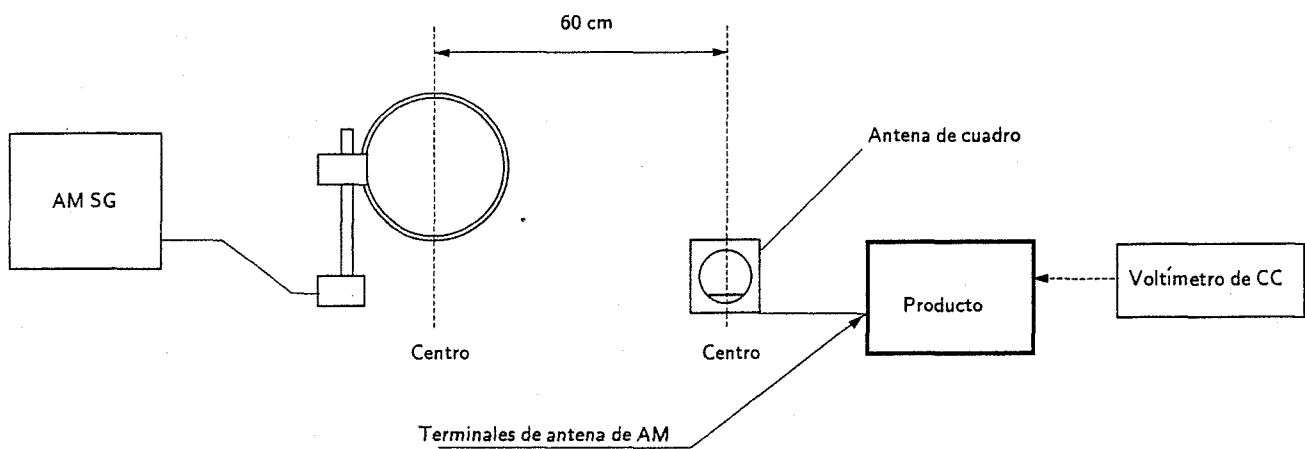

Fig. 6-1 Diagrama de conexiones para el ajuste de AM

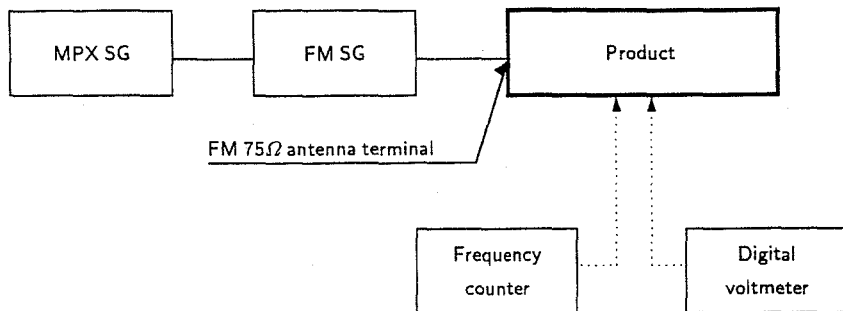

Fig. 6-2 FM Adjustment Connection Diagram

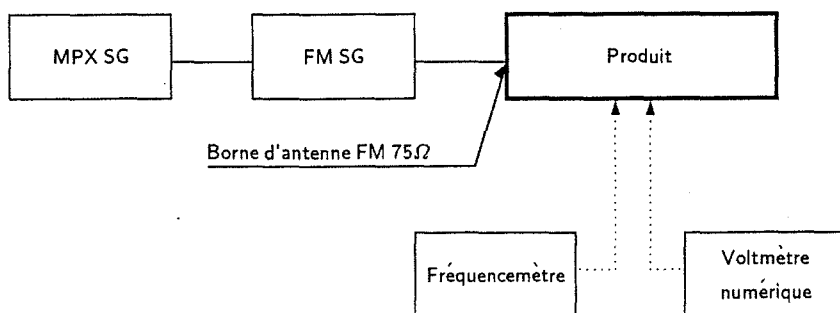

Fig. 6-2 Schéma de connexion de réglage FM

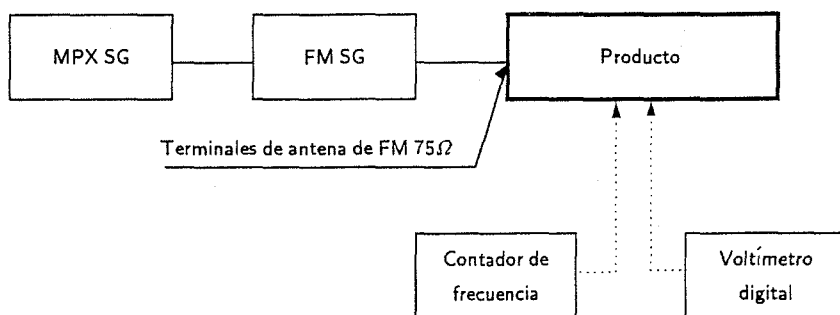

Fig. 6-2 Diagrama de conexiones para el ajuste de FM

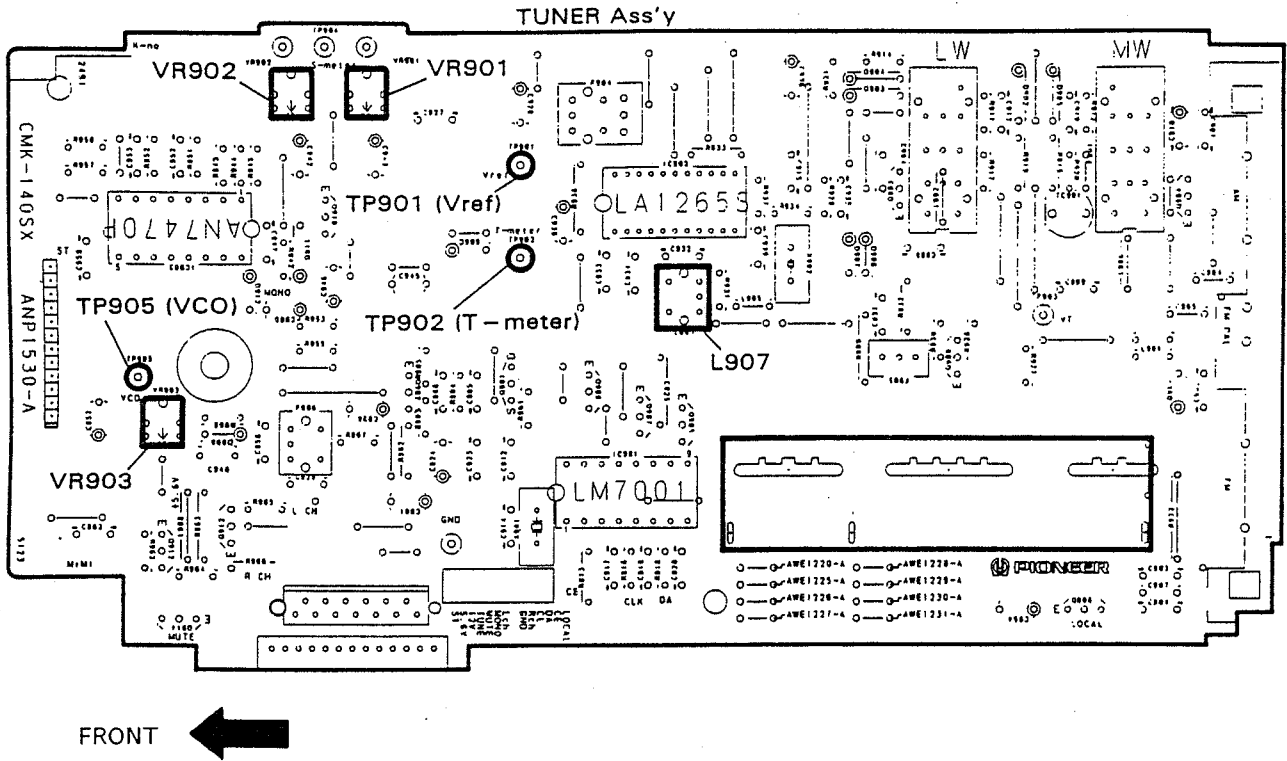

Fig. 6-3 Adjustment Points
Fig. 6-3 Emplacements de réglage
Fig. 6-3 Puntos de ajuste

7. FOR CX—J400/HB ; CX—J300/HE AND HB

NOTES :

- Parts without part number cannot be supplied.
- Parts marked by “●” are not always kept in stock. Their delivery time may be longer than usual or they may be unavailable.
- The \triangle mark found on some component parts indicates the importance of the safety factor of the part. Therefore, when replacing, be sure to use parts of identical designation.

CONTRAST OF MISCELLANEOUS PARTS

CX-J400/HB ; CX-J300/HE, HB and CX-J400/HE have the same construction except for the following :

Mark	Symbol & Description	Part No.				Remarks
		CX-J400/ HE type	CX-J400/ HB type	CX-J300/ HE type	CX-J300/ HB type	
\triangle	AC power cord	ADG1019	ADG1084	ADG1019	ADG1084	For packing
\triangle	AC outlet 1P	AKP-508	AKP-509	AKP-508	AKP-509	
	Front panel	AMB1899	AMB1899	AMB1898	AMB1898	
	Leg assembly	RXA1448	RXA1447	RXA1277	RXA1277	
	Packing case	AHD2184	AHD2184	AHD2185	AHD2185	