

Service Manual

ORDER NO.
CRT2300

CD MECHANISM MODULE

CX-916

- This service manual describes the operation of the CD mechanism incorporated in models listed in the table below.
- When performing repairs use this manual together with the specific manual for model under repair.

Model	Service Manual	CD Mechanism Module	Mechanism Unit
DEH-P400/X1N/UC DEH-P4000/X1N/UC DEH-P4050/X1N/ES	CRT2308	CXK5200	CXB3100
DEH-P3000R/X1N/EW	CRT2309	CXK5200	CXB3100
DEH-P200/X1N/UC DEH-P300/X1N/UC DEH-P3000/X1N/UC	CRT2310	CXK5200	CXB3100
DEH-P20/X1N/UC DEH-P2000/X1N/UC DEH-P2050/X1N/ES	CRT2311	CXK5200	CXB3100
DEH-2000R/X1N/EW DEH-2020R/X1N/GR DEH-2030R/X1N/EW	CRT2312	CXK5200	CXB3100
DEH-10/X1N/UC DEH-1000/X1N/UC DEH-1050/X1N/ES	CRT2313	CXK5200	CXB3100

CONTENTS

1. CIRCUIT DESCRIPTIONS	2
2. MECHANISM DESCRIPTIONS.....	17
3. DISASSEMBLY	18

1. CIRCUIT DESCRIPTIONS

The LSI (UPD63710GC) used on this unit comprises five main blocks ; the pre-amp section, servo, signal processor, DAC and CD text decoder (not used on this model). It also equips with nine automatic adjustment functions.

1.1 PRE-AMP SECTION

This section processes the pickup output signals to create the signals for the servo, demodulator and control.

The pickup output signals are I-V converted by the pre-amp with the built-in photo-detector in the pickup, then added by the RF amp to obtain RF, FE, TE, TE zero cross and other signals.

This pre-amp section is built in the servo LSI UPD63710GC (IC201). The following describes function of each section.

Since this system has a single power supply (+5V), the reference voltage for this LSI and pickup are set to REFO (2.5V). The REFO is obtained by passing the REFOUT from the LSI through the buffer amplifier. The REFO is output from Pin 89 of this LSI. All measurements are done using this REFO as reference.

Note : During the measurement, do not try to short the REFO and GND.

1) APC Circuit (Automatic Power Control)

When the laser diode is driven with constant current, the optical output has large negative temperature characteristics. Thus, the current must be controlled from the monitor diode so that the output may be constant. APC circuit is for it. The LD current is obtained by measuring the voltage between LD1 and V+5. The value of this current is about 35mA.

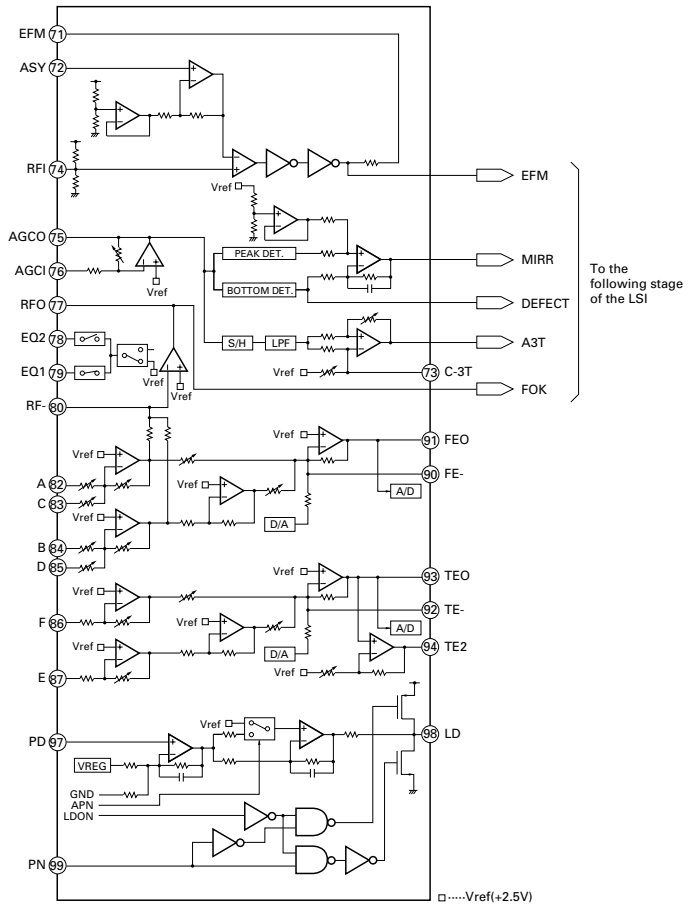

Fig.1 : BLOCK DIAGRAM OF BUILT-IN RF AMPLIFIER

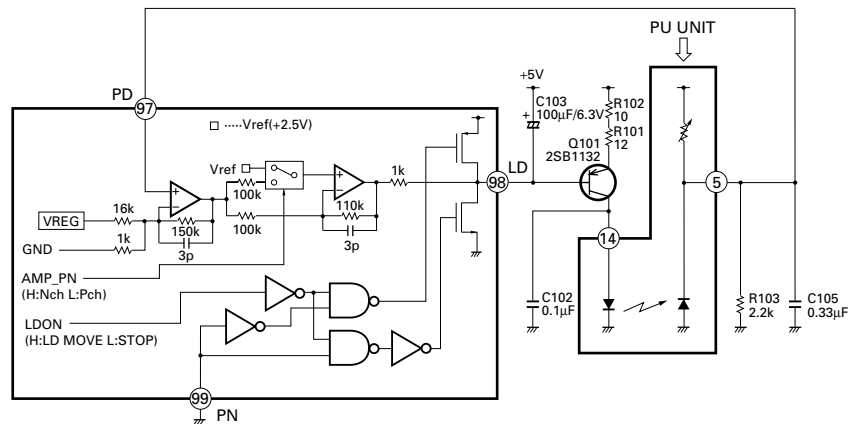

Fig.2 : APC CIRCUIT

2) RF Amplifier and RFAGC Amplifier

The photo-detector outputs (A + C) and (B + D) are added, amplified and equalized on this LSI and then output to the RFI terminal as the RF signal. (The eye pattern can be checked by this signal.)

The RFI voltage low frequency component is :

$$RFI = (A + B + C + D) \times 3.2$$

RFI is used on the FOK generator circuit and RF offset adjusting circuit.

R214 is an offset resistor for maintaining the bottom reference voltage of the RFI signal at 1.5 VDC. The D/A output used for the RF offset adjustment (to be described later) is entered via this resistor.

After the RFI signal from Pin 77 is externally AC coupled, entered to Pin 76 again, then amplified on the RFAGC amplifier to obtain the RFO signal.

The RFAGC adjustment function (to be described later) built-in the LSI is used for switching feedback gain of the RFAGC amplifier so that the RFO output may go to $1.5 \pm 0.3V_{pp}$.

The RFO signal is used for the EFM, DFCT, MIRR and RFAGC adjustment circuits.

3) RFOK Circuit

This circuit generates the signal that is used for indicating the timing of closing the focus or state of the focus close currently being played. This signal is output from Pin 4 as the FOK signal. It goes high when the focus close and in-play.

The RFOK signal is generated by holding DC level of the RFI at its peak with the succeeding digital section, then comparing it at a specific threshold level. Thus, the RFOK signal goes high even if the pit is absent. It indicates that the focus close can take place on the disc mirror surface, too.

This signal is also supplied to the micro computer via the low pass filter as the FOK signal and used for the protection and the RF amplifier gain switching.

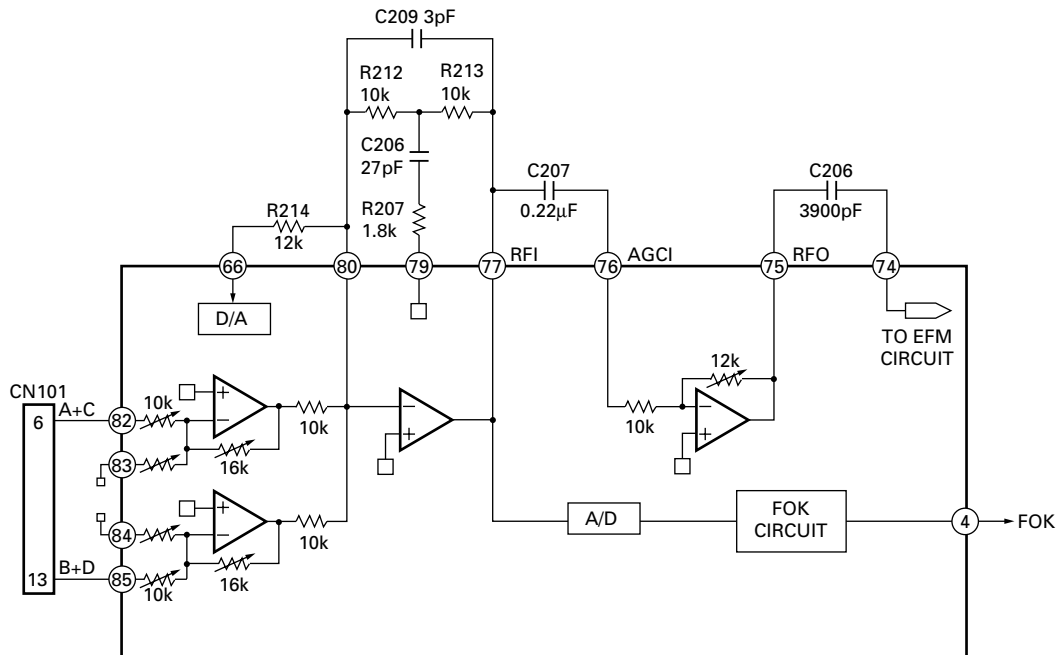

Fig.3 : RFAMP, RFAGC AND FOK CIRCUIT

4) Focus Error Amplifier

The photo-detector outputs (A + C) and (B + D) are passed through a differential amplifier and an error amplifier, and then (A + C - B - D) is output from Pin 91 as the FE signal.

The FE voltage low frequency component is :

$$FE = (A + C - B - D) \times \frac{16k}{10k} \times \frac{(80k/300k)}{20k}$$

$$= (A + C - B - D) \times 5$$

Using REFO as the reference, an S-curve of approximately 1.5 Vpp is obtained for the FE output. The final-stage amplifier cutoff frequency is 11.4 kHz.

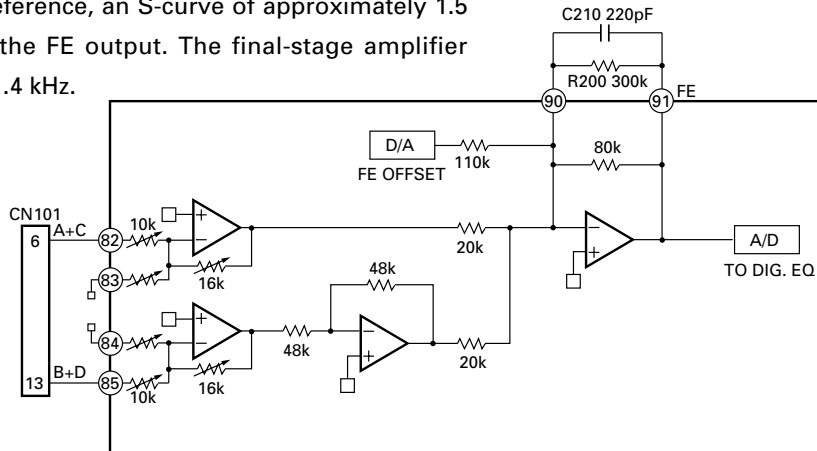

Fig.4 : FOCUS ERROR AMPLIFIER

5) Tracking Error Amplifier

The photo-detector outputs E and F are passed through a differential amplifier and an error amplifier, and then (E - F) is output from Pin 93 as the TE signal. The TE voltage low frequency component is :

$$TE = (E - F) \times \frac{224k}{(56k+27k)} \times \frac{80k}{38k}$$

$$= (E - F) \times 5.7 \text{ (Effective LSI output is 5.0).}$$

Using REFO as the reference, the TE waveform of approximately 1.3 Vpp is obtained for the TE output. The final-stage amplifier cutoff frequency is 20 kHz.

6) Tracking Zero Crossing Amplifier

TEC signal (the tracking zero crossing signal) is obtained by multiplying the TE signal four times. It is used for locating the zero crossing points of the tracking error. The zero cross point detection is done for the following two reasons :

- ① To count tracks for carriage moves and track jumps.
- ② To detect the direction in which the lens is moving when the tracking is closed (it is used on the tracking brake circuit to be described later).

The TEC signal frequency range is 300 Hz to 20 kHz.

$$TEC \text{ voltage} = TE \text{ level} \times 4$$

Theoretical TEC level is 5.2V. The signal exceeds D-range of the operational amplifier and thus is clipped. It, however, can be ignored since this signal is used by the servo LSI only at the zero crossing point.

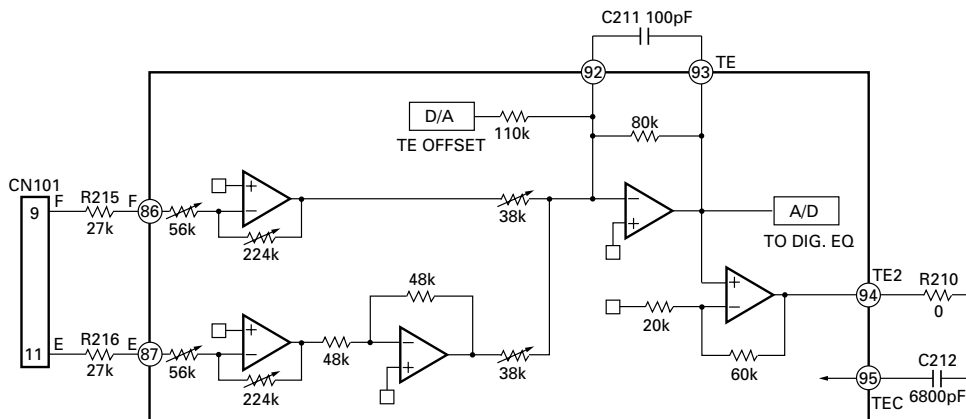

Fig.5 TRACKING ERROR AMPLIFIER AND TRACKING ZERO CROSSING AMPLIFIER

7) DFCT (Defect) Circuit

The DFCT signal is used for detecting defects on the mirrored disc surface. It allows monitoring from the HOLD pin (Pin 2). It goes high when defects are found on the mirrored surface.

The DFCT signal is generated by comparing the RF amplified signal (which is obtained by bottom holding the RFO signal) at a specific threshold level by the succeeding digital section.

Stains or scratches on the disc can constitute the defects on the mirrored disc surface. Thus, as long as the DFCT signal remains high in the LSI, the focus and tracking servo drives are held in the current state so that a better defect prevention may be ensured.

8) 3TOUT Circuit

The 3TOUT signal is generated by entering disturbance to the focus servo loop, comparing phase of fluctuations of the RF signal 3T component against that of the FE signal at that time, then converting the signal to DC level. This signal is used for adjusting bias of the FE signal (to be described later). This signal is not output from the LSI, thus its monitoring is not available.

9) MIRR (Mirror) Circuit

The MIRR signal shows the on track and off track data, and is output from Pin 3.

When the laser beam is

On track : MIRR = "L"

Off track : MIRR = "H"

This signal is used on the brake circuit (to be described later) and also as the trigger to turn on track counting when jumping take place.

The MIRR signal is supplied to the micro computer, too, for the protection purpose.

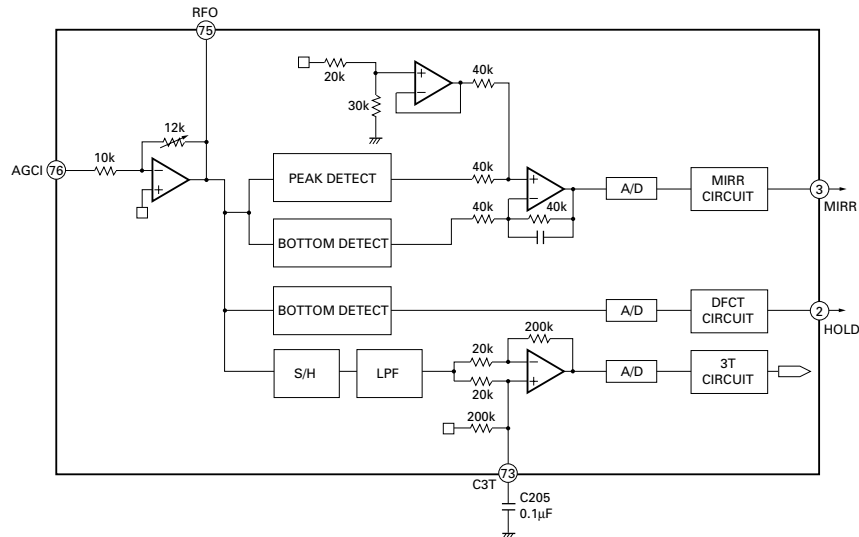

Fig.6 : DFCT, MIRR AND 3T DETECTION CIRCUIT

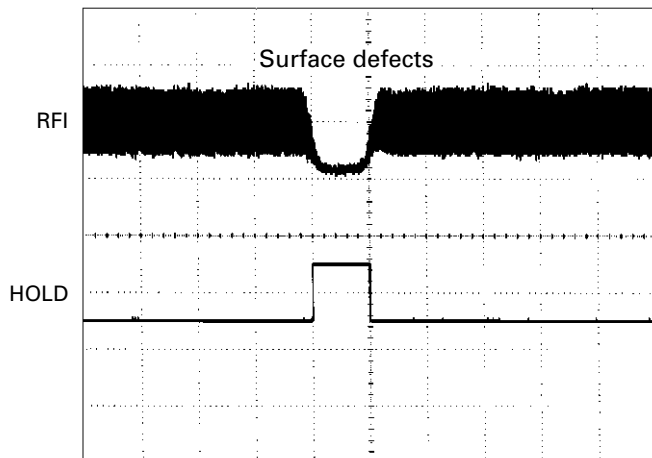

Fig.7 : HOLD OUTPUT WAVEFORM
(When surface defects are present)

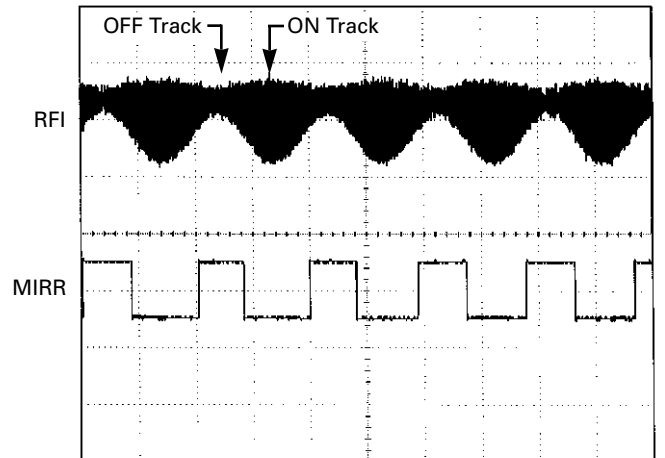

Fig.8 : MIRR OUTPUT WAVEFORM
(When an access is made)

10) EFM Circuit

This circuit is used for converting the RF signal to digital signal consisting of "0" and "1". The RFO signal from Pin 75 is externally AC coupled, entered to Pin 74, then applied to the EFM circuit.

Loss of the RF signal due to scratches or stains on the disc, or vertical asymmetry of the RF due to variations in the discs manufactured can't be eliminated by AC coupling alone. This circuit, therefore, controls the reference voltage ASY on the EFM comparator by use of the fact that "0" and "1" appear fifty fifty in the EFM signal. By this arrangement, the compare level is constantly maintained at almost center of the RFO signal level. The reference voltage ASY is generated when the EFM comparator output is passed through the low pass filter. The EFM signal is output from Pin 71. It is a 2.5 Vp-p amplitude signal centering on REFO.

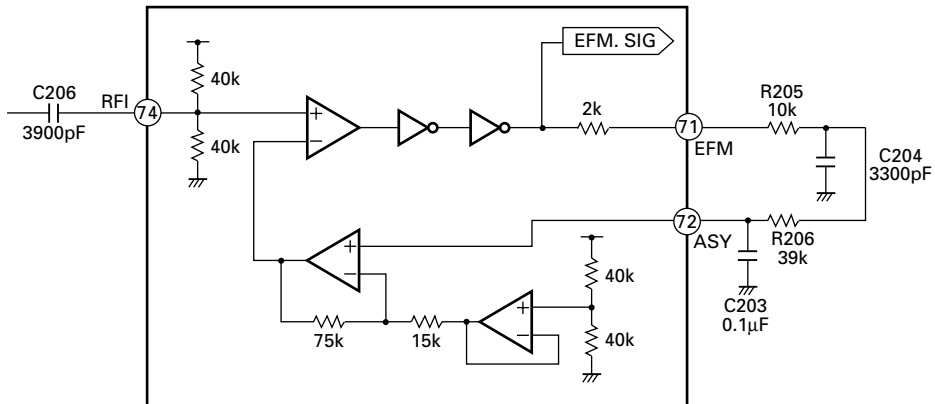

Fig.9 : EFM CIRCUIT

1.2 SERVO SECTION (UPD63710GC : IC201)

The servo section controls the operations such as error signal equalizing, in focus, track jump and carriage move. The DSP is the signal processing section used for data decoding, error correction and interpolation processing, among others.

This circuit implements analog to digital conversion of the FE and TE signals generated on the pre-amplifier, then outputs them through the servo block as the drive signal used on the focus, tracking and carriage system. The EFM signal is decoded on the signal processing section and finally output via the D/A converter as the audio signal. The decoding process also generates the spindle servo error signals which is fed to the spindle servo block to generate the spindle drive signal.

The focus, tracking, carriage and spindle drive signals are then amplified on the driver IC BA5985FM (IC301) and fed to respective actuators and motors.

1) Focus Servo System

The focus servo main equalizer is consisted of the digital equalizer. Fig.10 shows the focus servo block diagram.

When implementing the focus close on the focus servo system, the lens must be brought within the in-focus range. Therefore, the lens is moved up and down according to the triangular focus search voltage to find the focus point. During this time, the spindle motor is kicked and kept rotating as a set speed.

The servo LSI monitors the FE and RFOK signals and automatically carries out the focus close at an appropriate point.

The focus closing is carried out when the following three conditions are met :

- ① The lens approaches the disc from its current position.
- ② RFOK = "H"
- ③ The FZC signal is latched at high after it has once crossed the threshold set on the FZD register (Edge of the FZD).

As the result, the FE (= REFO) is forced to low.

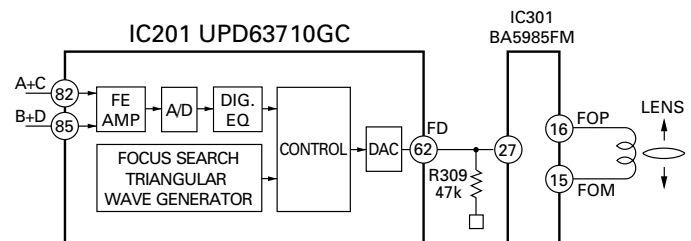

Fig.10 : FOCUS SERVO BLOCK DIAGRAM

When the above conditions are all met and the focus is closed, the XSI pin goes to low from the current high, then 40 ms later, the microcomputer begins to monitor the RFOK signal after it that has been passed through the low pass filter.

When the RFOK signal is recognized as low, the micro computer carries out various actions including protection.

Fig.11 a series of operations carried out relevant to the focus close (the figure shows the case where focus close is not available).

You can check the S-curve, search voltage and actual lens behavior by selecting the Display 01 for the focus mode select in the test mode, and then pressing the focus close button.

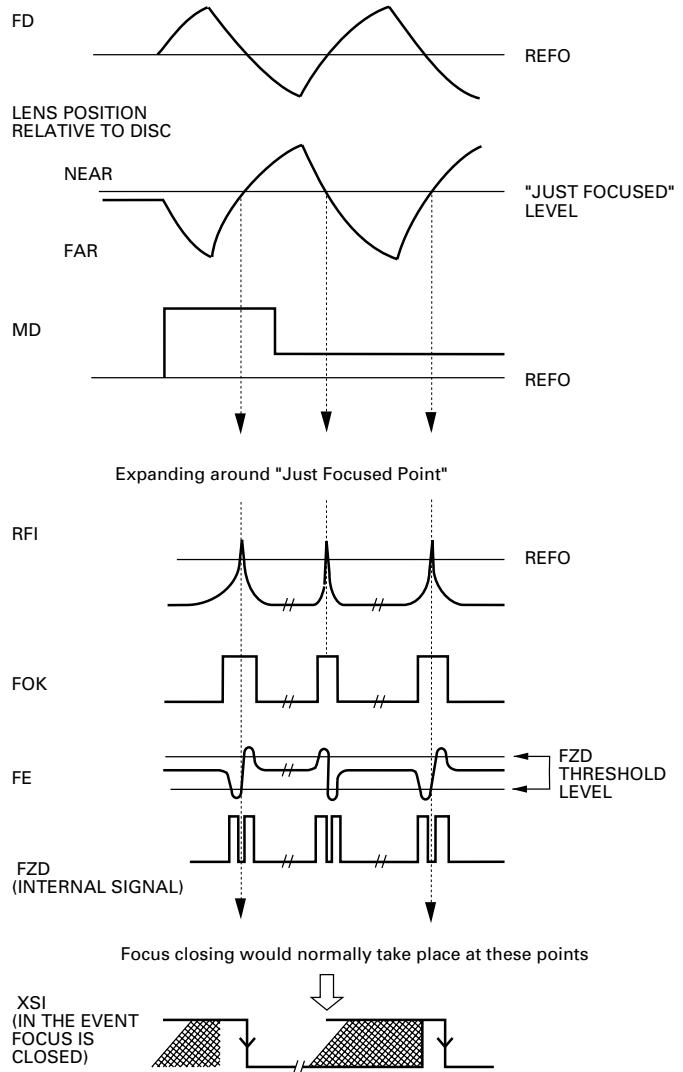

Fig.11 : FOCUS CLOSE SEQUENCE

2) Tracking Servo System

The digital equalizer is employed for the main equalizer on the tracking servo. Fig.12 shows the tracking servo block diagram.

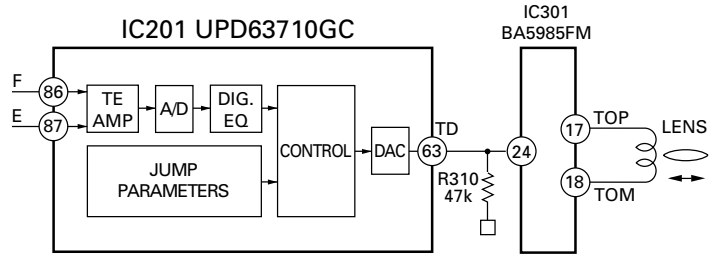

Fig.12 : TRACKING SERVO BLOCK DIAGRAM

a) Track jump

When the LSI receives the track jump command from the microcomputer, the operation is carried out automatically by the auto sequence function of the LSI. This system has five types of track jumps used for the search : 1, 4, 10, 32 and 32×3 . In the test mode, in addition to three jumps (1, 32 and 32×3), move of the carriage can be check by mode selection. For track jumps, the microcomputer sets almost half of tracks (5 tracks for 10 tracks, for instance) and counts the set number of tracks using the TEC signals. When the microcomputer has counted the set number of tracks, it outputs the brake pulse for a fixed period of time (duration can be specified with the command) to stop the lens. In this way, the tracking is closed and normal play is continued.

To improve the servo loop retracting performance just after the track jump, the brake circuit is turned on for 50 ms after the brake pulse has been terminated to increase gain of the tracking servo.

Fast forward and reverse operations are realized by through consecutive signal track jumps. The speed is about 10 times as fast as that in the normal mode.

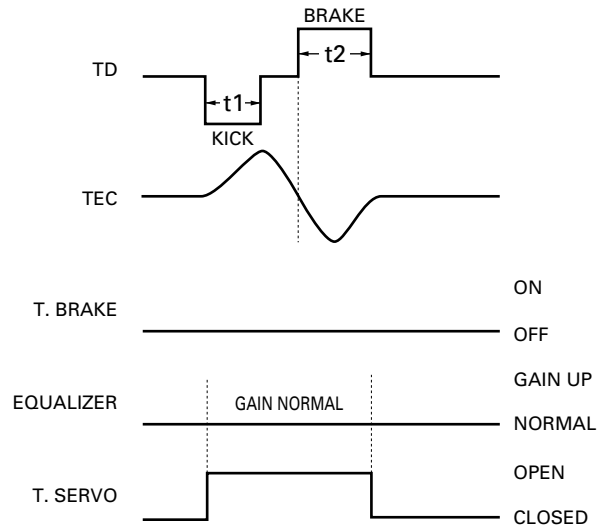

Fig.13 : SINGLE TRACK JUMP

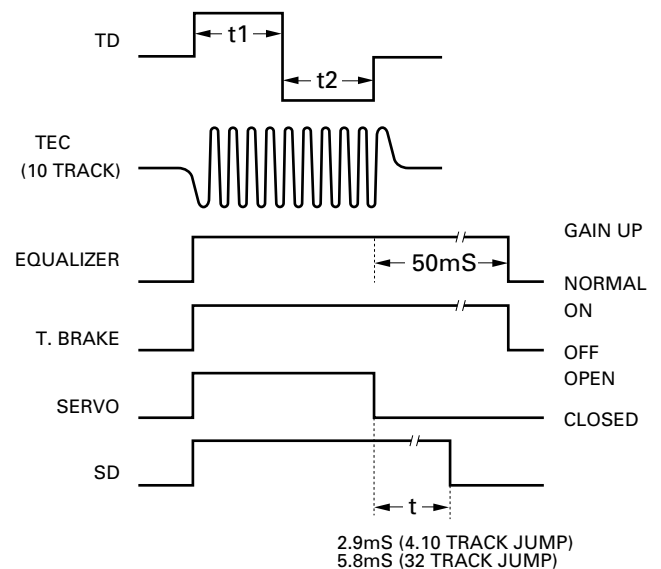
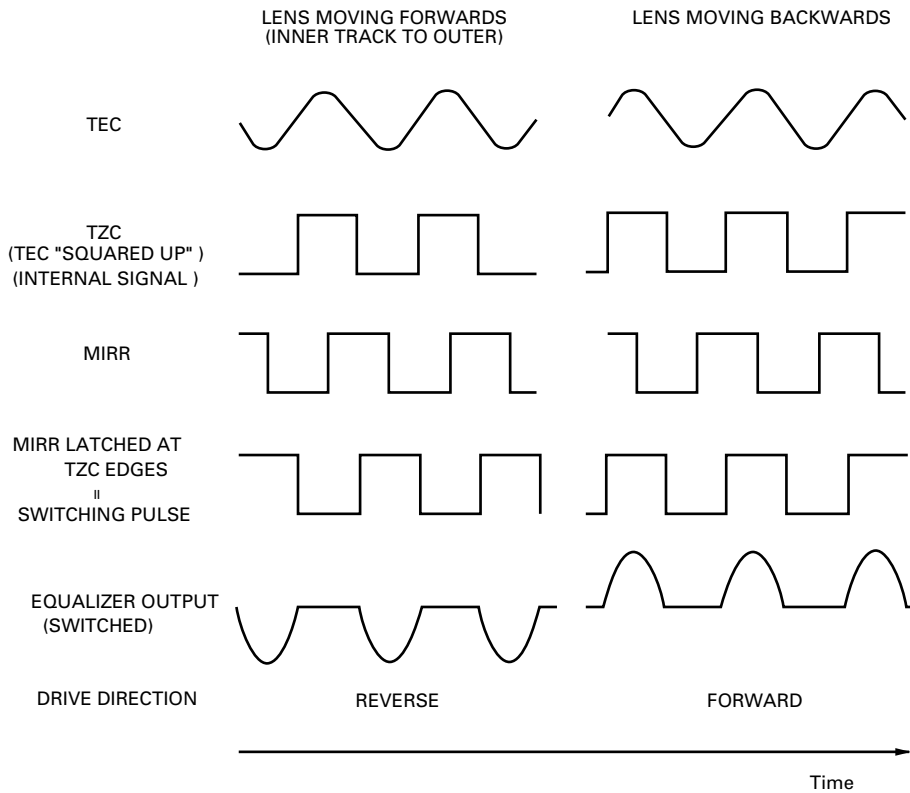

Fig.14 : MULTI-TRACK JUMP

b) Brake Circuit

The servo retracting performance can be deteriorate during the setup or track jump operation. In this connection, the brake circuit is used to ensure steady retract of the tracking servo. The brake circuit detects in which direction the lens is moving, then slows down its move by outputting the drive signal that moves the lens into the opposite direction alone. Track slippage direction is determined by referencing the TEC and MIRR signals and their phase.



Note : Equalizer output assumed to have same phase as TEC.

Fig.15 : TRACKING BRAKE CIRCUIT

3) Carriage Servo System

The carriage servo supplies the tracking equalizer's low-frequency component (lens position data) output to the carriage equalizer, then, after providing a fixed amount of gain to it, outputs the drive signal from the LSI. This signal is then applied to the carriage motor via the driver IC.

When the lens offset reaches a certain level during play, the entire pickup must be moved into the forward direction. Therefore, the equalizer gain is set to the level that allows to generate a voltage higher than the carriage motor starting voltage. In actual operations, a certain threshold level is set for the equalizer output by the servo LSI so that the drive voltage may be output from the servo LSI only when the equalizer output exceeds the threshold level. This arrangement helps reducing power consumption. Also, due to disc eccentricity or other factors, the equalizer output may cross the threshold level a number of times. In this case, the drive voltage output from the LSI will have pulse-like waveform.

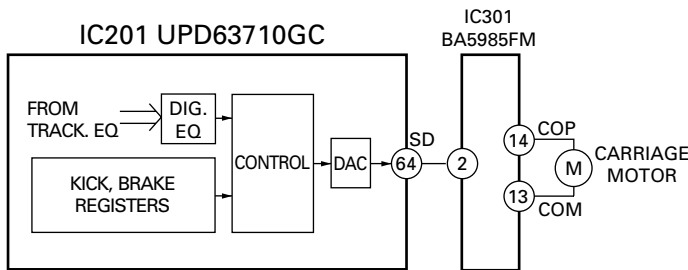

Fig.16 : CARRIAGE SERVO BLOCK DIAGRAM

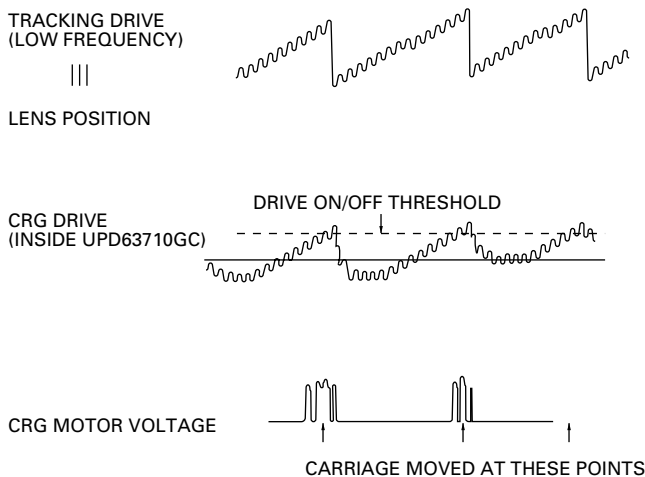

Fig.17 : CARRIAGE SIGNAL WAVEFORM

4) Spindle Servo System

The spindle servo has the following modes.

- ① Kick :
This mode is used for accelerating the disc rotation during setup.
- ② Offset :
(a) After the kick is over in the setup, this mode is turned on until changing to rough servo mode.
(b) When focus is lost during play, this mode is turned on until the focus is restored.
Both of the above are used for maintaining the disc rotation rate near to the specified rate.

③ Applicable servo :
The CLV servo mode is turned on for the normal operations.
In the EFM demodulation block, the frame sync signal and internal counter output signal are sampled for every WFCK/16 and a signal is produced for indicating whether or not they are matching. They are determined to be asynchronous only when this signal fails to match 8 times in succession. In all other cases, above two signals are assumed to be synchronous. In the applicable servo mode, the retracting servo is automatically selected if the two signals are synchronous. If not, the regular servo is automatically selected.

④ Brake :
This mode is turned on when stopping the spindle motor.
The microcomputer outputs the brake voltage through the servo LSI. The LSI monitors the EFM waveform and, if its longest pattern exceeds a certain interval (if the rotation is sufficiently slow), the flag is set the LSI and the microcomputer turns off the brake voltage. When the flag is not up within a specified period time, the microcomputer switches the mode from the brake to the stop mode, and maintains this mode for a fixed period of time. If this stop mode is continued for a fixed period of time, the disc will be ejected.

⑤ Stop :
This mode is used for powering on the system and the eject operation. When this mode is turned on, voltage across the spindle motor is 0V.

⑥ Rough servo :
This mode is used for when the carriage feed (carriage mode for the long search, etc.) is turned on. The linear speed is calculated from the EFM waveform and high or low level is entered to the spindle equalizer. In the test mode, this mode is also used for the grating check.

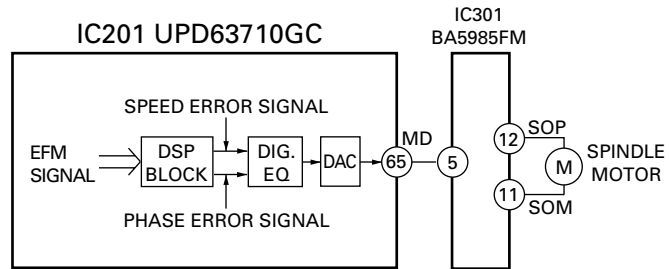

Fig.18 : SPINDLE SERVO MOTOR BLOCK DIAGRAM

1.3 AUTOMATIC ADJUSTMENT FUNCTIONS

Every circuit adjustment on the CD-LSI of this system is automated.

Every circuit adjustment is automatically implemented when the disc is inserted or the CD mode is selected from the source key. The following describes how the adjustments are executed.

1) FZD Cancel Setting

This setting is used for executing the focus close operation without fail.

When power is turned on, the FE offset level is read and a voltage opposite to this offset value is written to the CRAM on the IC to cancel the offset. In this manner, the FZD threshold level can be set to a constant value (+240mV), thereby ensuring to meet one of the requirements for the IC to execute the focus close that "the FZD signal is latched at high".

2) Automatic Adjustment of TE, FE and RF Offset

Using REFO as the reference, this function adjusts the pre-amp TE, FE and RF offsets to the respective target value when power is turned on (targets values of the TE, FE and RF are 0, 0 and -1V, respectively).

The following is the adjustment procedure :

- (1) Respective offset (LD off) is read by the microcomputer via the servo LSI.
- (2) The microcomputer calculates the voltages to be corrected from the read values, then sets them to the specified field.

3) Automatic Adjustment of Tracking Balance (T. BAL)

This adjustment is used for eliminating differences between the pickup E and F channels outputs by adjusting gain of the amplifier on the LSI. In the actual operation, the TE waveform is adjusted so that it may be vertically symmetric with REFO.

The following is the adjustment procedure :

- (1) Make sure the focus close is complete.
- (2) Kick the lens in the radial direction to generate the TE waveform.
- (3) At this time, the microcomputer reads the TE signal offset value (via the servo LSI) being calculated by the LSI.

- (4) The microcomputer determines if the read offset value is positive, negative or zero.

If the offset value = 0, the adjustment is terminated.

If the offset value = A positive or negative value, gain of the E and F channels amplifiers are modified according the predetermined rule.

Then above steps (2) through (4) are repeated until the "Offset value = 0" or "Specified limit count" is reached.

4) Automatic Adjustment of FE Bias

This adjustment is intended at maximizing the RFI level by optimizing the focus point in-play. This adjustment utilizes the phase difference between the RF waveform 3T level and the focus error signal when disturbance is applied.

Since disturbance is applied to the focus loop, this adjustment is designed to take place in the same timing as the auto gain control (to be described later).

The following is the adjustment procedure :

- (1) Disturbance is injected to the focus loop by the command from the microcomputer (within the servo LSI).
- (2) The LSI detects fluctuation of the RF signal 3T component level.
- (3) The LSI determines relationship between fluctuation of the 3T component and the injected disturbance to detect magnitude and direction of the off-focus introduced.
- (4) The microcomputer reads the detected results from the LSI.
- (5) The microcomputer calculates necessary correction, then hands the calculated value to the bias adjustment term set on the LSI.

This adjustment is repeated several times, as it is so with the auto gain control, to ensure higher accuracy.

5) Focus and Tracking Automatic Gain Control

This function is used for implementing automatic control of the focus and tracking loop gain.

The following is the adjustment procedure :

- (1) Inject disturbance to the servo loop.
- (2) Extract the error signal (FE and TE) generated at when the disturbance is applied to obtain the signals G1 and G2 via the B.P.F.
- (3) The microcomputer reads the G1 and G2 signals via the LSI.
- (4) Based on the necessary correction calculated by the microcomputer, the LSI performs the loop gain adjustment.

Above adjustments are repeated several times to ensure higher adjustment accuracy.

6) Automatic RF Level Adjustment (RFAGC)

This adjustment is used for implementing intended signal transmission successfully by adjusting unevenness of the RF signal (RFO) levels, that results from disc and machine relevant factors, to a target value. The adjustment is actually done by varying gain of the amplifier provided between the RFI and RFO.

The following is the adjustment procedure :

- (1) Using the command, the microcomputer reads the output from the RF level detection circuit on the servo LSI.
- (2) Based on the read value, the microcomputer calculates an amplifier gain that will produce the target RFO level.
- (3) The microcomputer sends the corresponding command to the servo LSI so that the above gain value may be set.

This adjustment takes place at the following timing :

- When the focus close alone is completed during the setup process.
- Just before the setup is completed (just before the play takes place).
- After the off-focus has been corrected during the play.

7) Adjustment of Pre-Amp Stage Gain

It is used for adjusting the entire RFAMP (FE, TE and RF amplifiers) to +6dB or +12dB depending on given gain level when reflected light from the disc is significantly below the required level due to stained lens. This phenomena can be noticed when playing back the CD-RW.

The following is the adjustment procedure :

When reflected light from disc is judged to be significantly below the required level during the setup, set the entire RFAMP to +6dB or +12dB. In this case, if the gain is modified, the setup have to be repeated from the first step.

Through the adjustment, if you judged the play becomes available by setting the entire RFAMP to +6dB, +6dB should be selected for the setup next time on.

See the figure below :

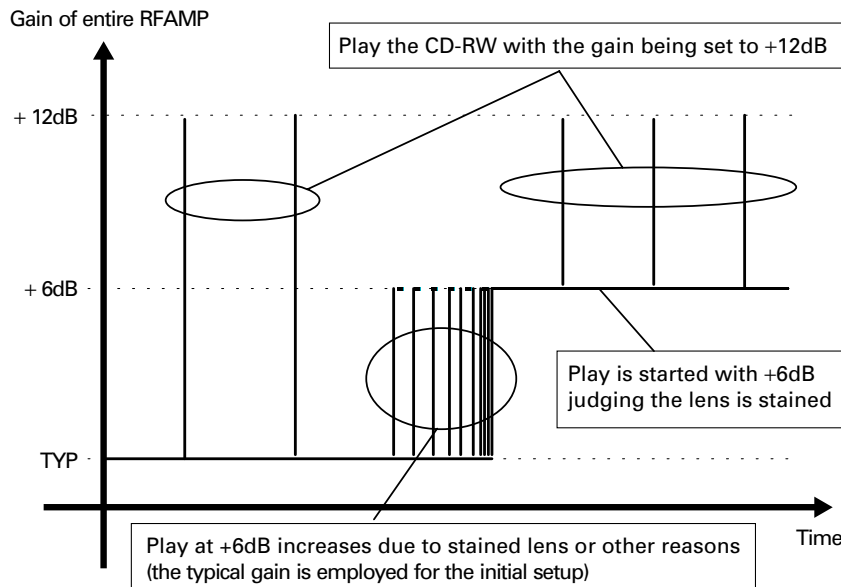

Fig.19 : CONCEPTUAL DIAGRAM OF PRE-AMP GAIN ADJUSTMENT

8) Initial Adjusting Values

All the automatic adjustments are implemented using the previous adjustment values as the initial values unless the microcomputer power (the backup power) is not turned off (though there are some exceptions).

When the backup is turned off, automatic adjustment is executed based on the initial values rather than the previous adjustment values.

9) Displaying Coefficients After Adjustment

You can display and check results of some automatic adjustments (FE and RF offset, FZD cancel and F / T / RFAGC) from the test mode. The following coefficients are displayed in each automatic adjustment :

(1) FE and RF offset and FZD cancel

Reference value = 32 (The coefficient of 32 indicates that no adjustment was required).

The results are displayed in multiples of approximately 40 mV.

An example : When FZD cancel coefficient = 35

$$35 - 32 = 3$$

$$3 \times 40 \text{ mV} = 120 \text{ mV}$$

Since the corrected value is approximately +120 mV, the FE offset before adjustment was -120 mV.

(2) F and T gain adjustment

Reference value = Focus/Tracking = 20

A coefficient displayed indicates an amount of adjustment conducted on the reference value.

An example : When AGC coefficient = 40

$40/20 =$ Overall gain has been doubled (+6dB). (The original loop gain of 1/2 has been doubled to have the targeted overall gain.)

(3) RF level adjustment (RFAGC)

Reference value = 8

Coefficient = 9 to 15 The direction in which the RF level is increased (the gain is increased).

Coefficient = 7 to 0 The direction in which the RF level is decreased (the gain is decreased).

Incrementing or decreasing the coefficient by "1" varies the gain by 0.7 to 1dB.

Maximum gain = Typically +6.5dB. Coefficient at this time is 15.

Minimum gain = Typically -6.0dB. Coefficient at this time is 0.

1.4 POWER SUPPLY AND LOADING SECTION

The power supply of the system uses VD (8.3V) from the mother board. VD is fed to 5 channel CD driver IC, 5V Reg IC and disc detection LED.

The microcomputer turns on or off the CD driver and the 5V using "CONT" and "CD5VON", respectively. The loading drive is turned on or off by the input signals "CDEJET" and "CDLOAD". No control terminal is provided for turning the loading drive on or off.

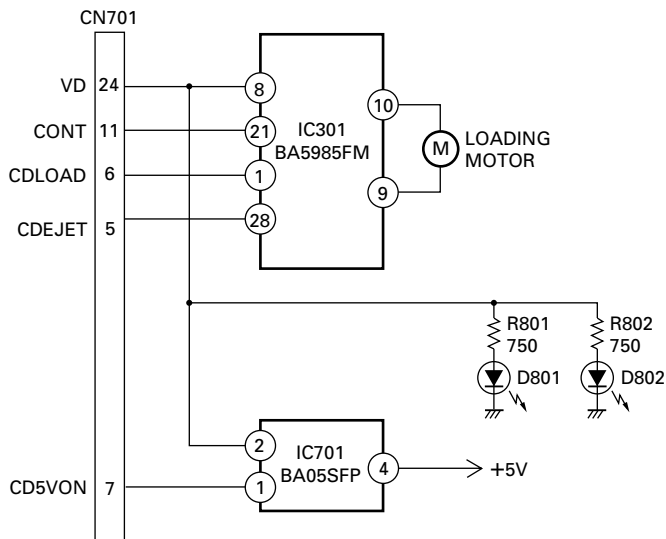
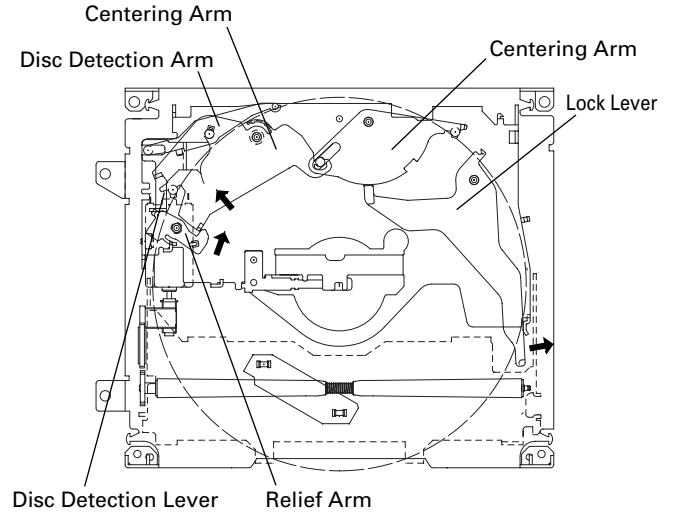

Fig.20 : POWER SUPPLY AND LOADING SECTION

2. MECHANISM DESCRIPTIONS

● Loading Operation (when a 12 cm disc is used)

1. Insert a 12 cm disc (the sensor turns on the motor revolution).
2. The disc pushes the Lock Lever in, thereby resetting the lock currently applied to the Centering Arms.
3. The disc further pushes the Centering Arms in.
4. The right side and left side arms are engaged to perform centering of the disc.
5. The disc pushes the Disc Detection Arm in, thereby pushing the Disc Detection Lever forward.
6. Clamping action retracts the Disc Detection Lever toward forward side, thereby rotating the Relief Arm.
7. The Relief Arm further pushes the Centering Arm in, thus detaching it from the disc.



● Loading Operation (when a 8 cm disc is used)

1. Insert an 8 cm disc (the sensor turns on the motor revolution).
2. The disc does not contact against the Lock Lever, thus centering of the disc is performed by the Centering Arm being locked.
3. When the right side slot is used, the lock currently applied to the Centering Arm remains turned on even if the disc may touch the Lock Lever because the disc leaves the lever before it reaches the Centering Arm.
4. Succeeding procedures are the same as that for 12 cm discs.

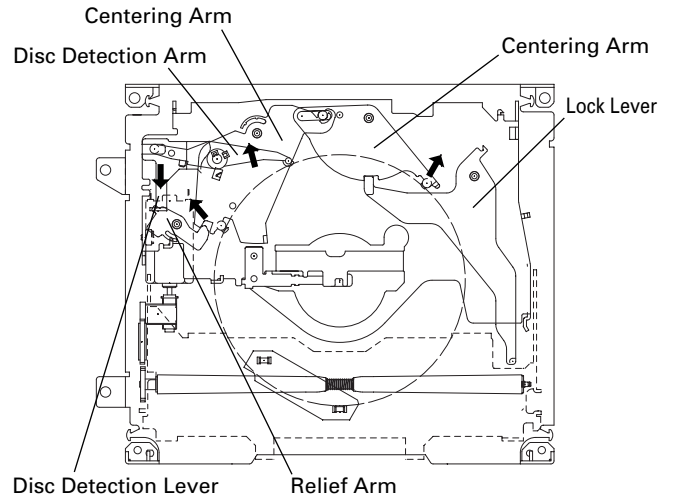

● Clamping Operation

1. Insert a disc.
2. The Detection Arm pushed forward by the Detection Lever turns on rotation of the Jump In Rack.
3. The Jump In Rack then engages with the Two Step Gear and moves toward right.
4. At the same time, the Mode Selector Lever connected to the Jump In Rack starts moving toward right, thereby rotating the Lock Arm and resetting the mechanical lock. The Clamp Up Arm too is rotated by the above action and, thus, the Clamp Up Arm now being lifted by shape of the cam of the Clamp Arm is lowered. And, the Guide Arm is also moved down because of shape of the cam of the Mode Selector Lever.
5. By use of the cam shape, the Jump In Rack being moved toward right retracts the Disc Detection Lever in forward direction, thereby turning on rotation of the Relief Arm.

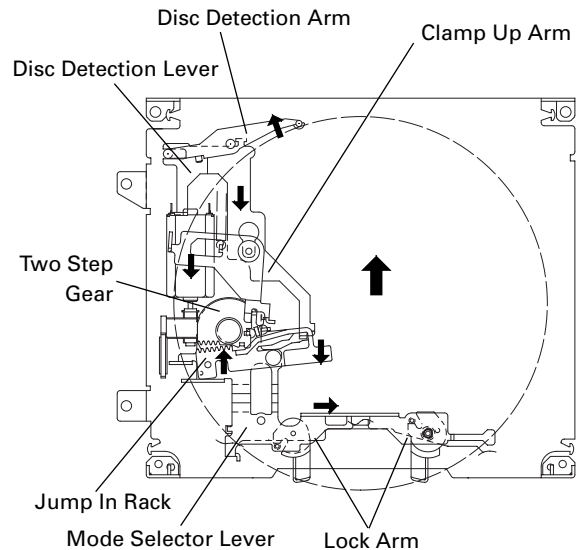

3. DISASSEMBLY

● Removing the Upper Frame

1. Remove six Springs A, two Springs B and four Screws.
2. Remove two Tabs situated on rear side of the Upper Frame, remove two Arms on the front side, then remove two Tabs on the front side.

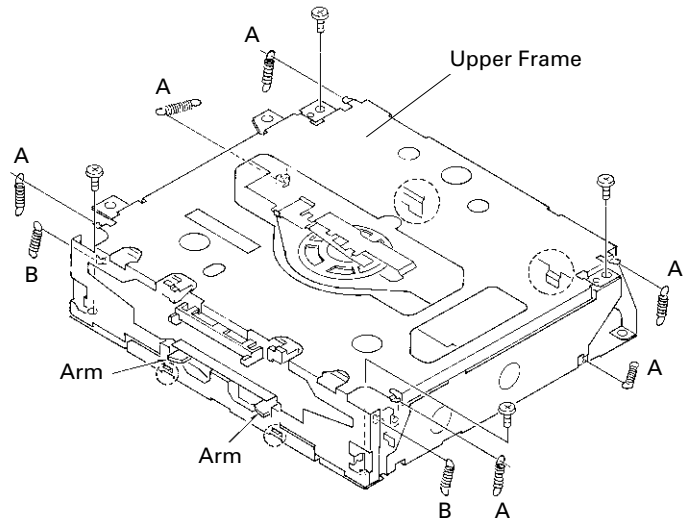

● Removing the Carriage Mechanism

1. Disengage the Carriage Mechanism from the two dampers situated in the front side by driving it up, then disengage and remove the mechanism from the two dampers by driving it up aslant into front side direction.

Note : When assembling the Carriage Mechanism, coat the dampers with alcohol prior to the assembly.

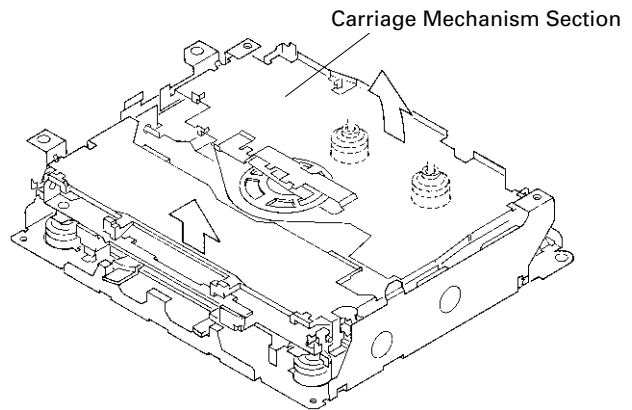

● Removing the Clamp Arm Assy

1. Remove a Spring A, a B and a Spring C.
2. Drive the Clamp Arm Assy up into rear side direction, then disengage the arm from its current position. Finally, drive the assembly approximately 45 degrees upward, then slide the assembly toward right side to remove it.

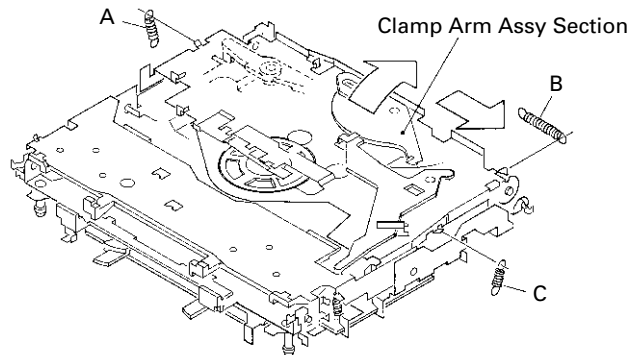

● **Removing the Guide Arm Assy**

1. Remove a connector, a spring A and B
2. Drive the Guide Arm Assy up aslant into rear side direction, then remove it from a Pin. Finally, drive the assembly approximately 45 degrees upward, then slide the assembly toward left side to remove it.

Note : When assembling the guide arm assembly, route the cord inside the assembly. In this operation, care must be exercised so that cord may be caught by the gear.

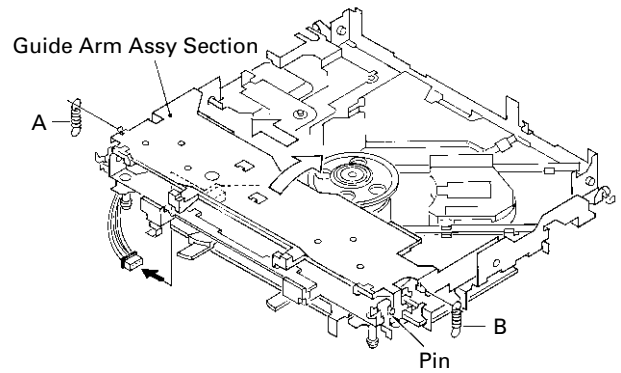

● **Removing the LO Arm Assy**

1. Remove two Pins to dismount the LO Arm Assy.

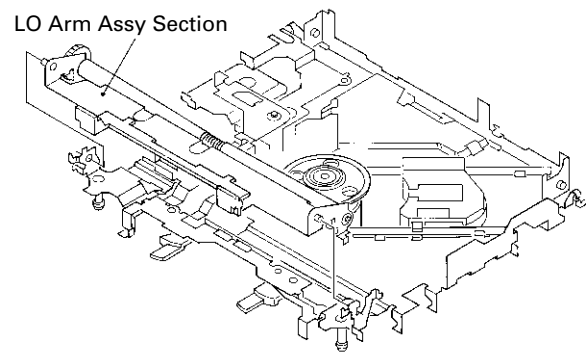

● **Removing the Control Unit and the Spindle Motor**

1. Remove from the connector after mounting the short pin on the flexible PCB of the pickup unit.
2. Remove two Soldered joints, then remove two Screws A.
3. Remove two connectors and a Screw B.
4. Disengage the Control Unit from two Tabs, then dismount the unit by sliding it toward left.
5. Dismount the Spindle Motor.

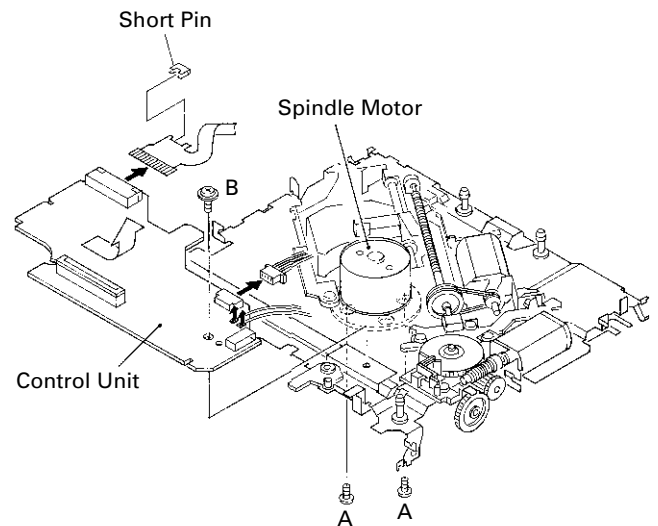

● **Removing the Loading Motor and Carriage Motor**

1. Remove the Spring and two Screws A.
2. Dismount the Loading Motor.
3. Remove the Belt, a Screw B, two Screws C, a Guide and a Screw Unit.
4. Dismount the Carriage Motor.

Note : When assembling the Belt, use care so that it may not be contaminated by grease.

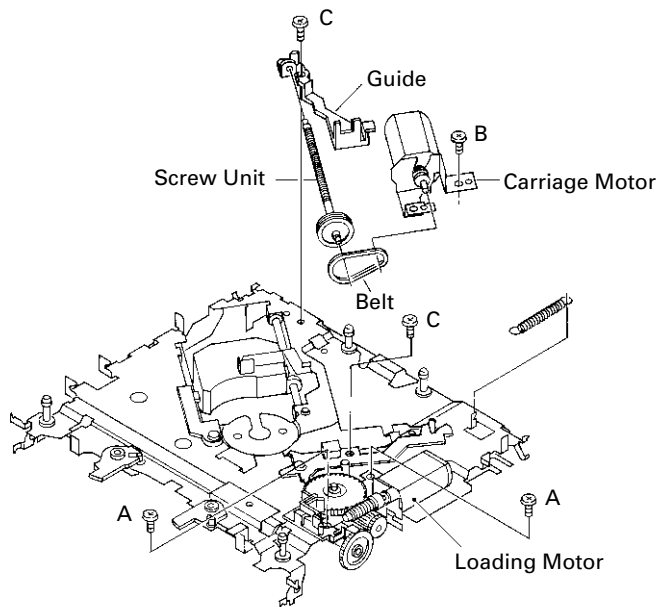

● **Removing the Pickup Unit**

1. Remove two Screws and a Shaft.
2. Dismount the Pickup Unit.

