

Service Manual

PIONEER
The Art of Entertainment

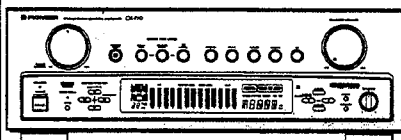

ORDER NO.
RRV1148

The chapter 1 of this Service Manual will not be reprinted. On your additional orders, we may supply only the chapter 2. For the chapter 1, please make copies and attach to the chapter 2 at your side if necessary.

STEREO TUNER CONTROL AMPLIFIER

CX-770S

CX-770

THIS MANUAL IS APPLICABLE TO THE FOLLOWING MODEL(S) AND TYPE(S).

Type	Model		Power Requirement	Remarks
	CX-770S	CX-770		
ZU	○	○	DC power supplied from other system component	
ZC	○	—	DC power supplied from other system component	

- This product is a component of a system.
For instruction manual, refer to the service manual RRV1166 for M-770.
- This product does not function properly when independent; to avoid malfunctions, be sure to connect it to the prescribed system component(s), otherwise damage may result.
- The "S" at the end of the model number indicates that a programmable remote control unit is supplied.

CONTENTS

CHAPTER 1

1.1 SAFETY INFORMATION	1-2
1.2 PANEL FACILITIES.....	1-3
1.3 SPECIFICATIONS	1-6
1.4 IC INFORMATION	1-7
1.5 FL INFORMATION	1-9
1.6 ADJUSTMENTS.....	1-10
1.7 TROUBLESHOOTING	1-12
1.8 PARTS LIST FOR REMOTE CONTROL UNIT (CU-CX007)	1-13
1.9 PARTS LIST FOR PACKING AND EXPLODED VIEWS	1-14
1.10 PCB PARTS LIST	1-15

CHAPTER 2

2.1 PACKING AND EXPLODED VIEWS ...	2-3
2.2 SCHEMATIC AND PCB CONNECTION DIAGRAMS	2-6
2.3 BLOCK DIAGRAM.....	2-33
2.4 REMOTE CONTROL UNIT (CU-CX007)	2-35

PIONEER ELECTRONIC CORPORATION 4-1, Meguro 1-Chome, Meguro-ku, Tokyo 153, Japan
PIONEER ELECTRONICS SERVICE INC. P.O. Box 1760, Long Beach, California 90801 U.S.A.
PIONEER ELECTRONICS OF CANADA, INC. 300 Allstate Parkway Markham, Ontario L3R 0P2 Canada
PIONEER ELECTRONIC [EUROPE] N.V. Haven 1087 Keetberglaan 1, 9120 Melsele, Belgium
PIONEER ELECTRONICS AUSTRALIA PTY. LTD. 178-184 Boundary Road, Braeside, Victoria 3195, Australia TEL: [03] 580-9911
© PIONEER ELECTRONIC CORPORATION 1994

T-FFF JUNE 1994 Printed in Japan

CHAPTER 1

1.1 SAFETY INFORMATION

This service manual is intended for qualified service technicians; it is not meant for the casual do-it-yourselfer. Qualified technicians have the necessary test equipment and tools, and have been trained to properly and safely repair complex products such as those covered by this manual.

Improperly performed repairs can adversely affect the safety and reliability of the product and may void the warranty. If you are not qualified to perform the repair of this product properly and safely, you should not risk trying to do so and refer the repair to a qualified service technician.



WARNING

Lead in solder used in this product is listed by the California Health and Welfare agency as a known reproductive toxicant which may cause birth defects or other reproductive harm (California Health & Safety Code, Section 25249.5).

When servicing or handling circuit boards and other components which contain lead in solder, avoid unprotected skin contact with the solder. Also, when soldering do not inhale any smoke or fumes produced.



NOTICE

(FOR CANADIAN MODEL ONLY)

Fuse symbols  (fast operating fuse) and/or  (slow operating fuse) on PCB indicate that replacement parts must be of identical designation.

REMARQUE

(POUR MODÈLE CANADIEN SEULEMENT)

Les symboles de fusible  (fusible de type rapide) et/ou  (fusible de type lent) sur CCI indiquent que les pièces de remplacement doivent avoir la même désignation.

(FOR USA MODEL ONLY)

1. SAFETY PRECAUTIONS

The following check should be performed for the continued protection of the customer and service technician.

LEAKAGE CURRENT CHECK

Measure leakage current to a known earth ground (water pipe, conduit, etc.) by connecting a leakage current tester such as Simpson Model 229-2 or equivalent between the earth ground and all exposed metal parts of the appliance (input/output terminals, screwheads, metal overlays, control shaft, etc.). Plug the AC line cord of the appliance directly into a 120V AC 60Hz outlet and turn the AC power switch on. Any current measured must not exceed 0.5mA.

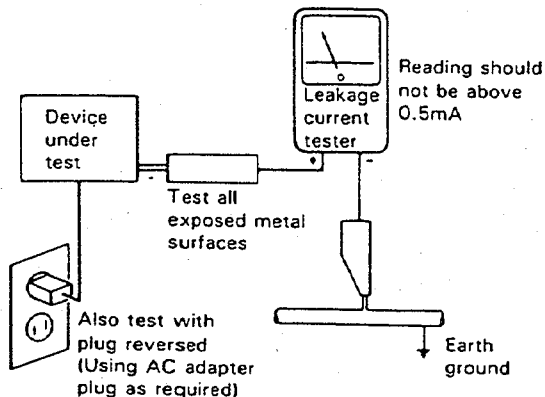

AC Leakage Test

ANY MEASUREMENTS NOT WITHIN THE LIMITS OUTLINED ABOVE ARE INDICATIVE OF A POTENTIAL SHOCK HAZARD AND MUST BE CORRECTED BEFORE RETURNING THE APPLIANCE TO THE CUSTOMER.

2. PRODUCT SAFETY NOTICE

Many electrical and mechanical parts in the appliance have special safety related characteristics. These are often not evident from visual inspection nor the protection afforded by them necessarily can be obtained by using replacement components rated for voltage, wattage, etc. Replacement parts which have these special safety characteristics are identified in this Service Manual.

Electrical components having such features are identified by marking with a Δ on the schematics and on the parts list in this Service Manual.

The use of a substitute replacement component which does not have the same safety characteristics as the PIONEER recommended replacement one, shown in the parts list in this Service Manual, may create shock, fire, or other hazards.

Product Safety is continuously under review and new instructions are issued from time to time. For the latest information, always consult the current PIONEER Service Manual. A subscription to, or additional copies of, PIONEER Service Manual may be obtained at a nominal charge from PIONEER.

1.2 PANEL FACILITIES

■ TUNER CONTROL AMPLIFIER SECTION

• Illustration shows model CX-770.

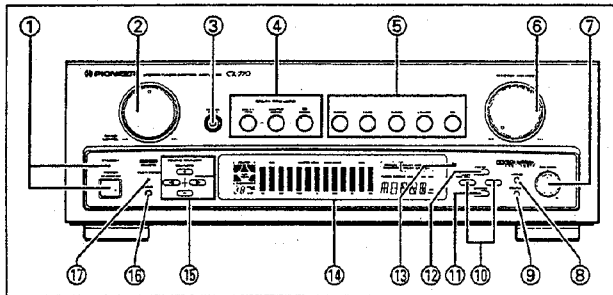

① POWER (STANDBY/ON) switch and STANDBY indicator

This is the switch for electric power.

ON : When set to the ON position, power is supplied and the unit becomes operational.

STANDBY : When set to the STANDBY position, the main power flow is cut and the unit is no longer fully operational. A minute flow of power feeds the unit to maintain operation readiness. When the STANDBY indicator is on, the unit is in STANDBY.

Disconnect the power cord from the power outlet when you do not plan to use the power amplifier for a long period of time.

② BASS LEVEL control

Press the POWER BASS button ON and the bass level can be changed.

To adjust the low and high frequency sound, use the POWER BASS level control.

When this control is set to the MIN position, the sound has no effect. To boost the low and high frequency sound, rotate the control to the right (to the MAX position).

③ POWER BASS button

Use to switch the POWER BASS function on and off. (For emphasized bass sounds.)

④ SURROUND function button(s)

Surround play back is not possible with a monophonic sound source (no sound from rear speaker).

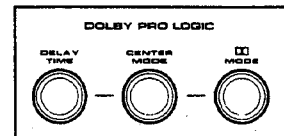

• DOLBY MODE button

Used to select a desired DOLBY mode position.

The mode changes in the following manner each time this button is pressed.

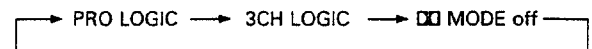

• DELAY TIME button

Use this button to select a delay time.

The time changes in the following manner each time this button is pressed.

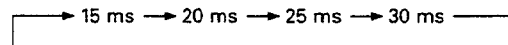

• CENTER MODE button

This button selects the surround center mode.

⑤ Function buttons

The selected mode is indicated in the display.

⑥ MASTER VOLUME control

The volume is increased when this control is turned clockwise, decreased when turned counterclockwise.

⑦ BALANCE control

Use this control to adjust the left-right balance for the front speakers.

⑧ MONO button

During FM reception: Switches between stereo and monaural modes when listening to a stereo broadcast. If there is too much noise in the stereo position, switch to MONO and the noise will be suppressed.

⑨ MEMORY button

This button is used to memorize stations. When the button is pressed, the frequency indication will flash.

⑩ TUNING/STATION CALL buttons (-, +)

These are used to locate stations. Push the "-" button to locate a station broadcasting on a lower frequency and the "+" button to locate a station on a higher frequency.

⑪ ST/FREQ (station/frequency) button

Use this button to select between STATION CALL and FREQUENCY position.

STATION CALL : This is used to preset stations and recall preset stations.

FREQUENCY : See item ⑩, TUNING/STATION CALL buttons.

⑫ FM/AM selector button

This is used to select the band of the desired station. The bands change alternately each time the button is pressed.

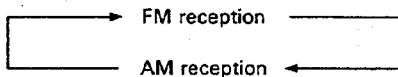

⑬ REMOTE SENSOR window

⑭ Display section

Shows the received broadcast frequency or station call number, reception conditions and graphic equalizer level settings. For more details, refer to DISPLAY FACILITIES.

⑮ GRAPHIC EQUALIZER controls

The advantage of the GRAPHIC EQUALIZER over conventional tone controls is that the controls of the GRAPHIC EQUALIZER make it possible to control seven different narrow, distinct sections of the audio band. With conventional tone controls a setting for a bass or treble boost or cut will also affect the lower or upper mid frequencies. The seven frequency bands controlled by the cursor controls have been chosen to yield the maximum possible control action within the audio spectrum.

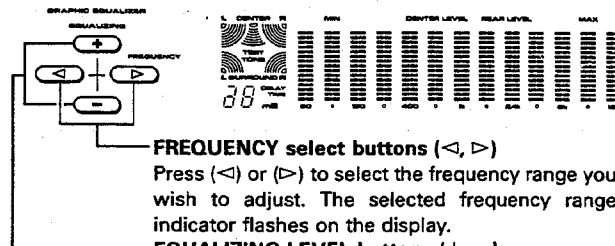

FREQUENCY select buttons (<, >)

Press (<) or (>) to select the frequency range you wish to adjust. The selected frequency range indicator flashes on the display.

EQUALIZING LEVEL buttons (+, -)

Adjust the level of the selected frequency range. Press (+) to increase the level and press (-) to decrease it.

To return to the flat position, press the EQUALIZING (+), (-) buttons simultaneously.

NOTE:

- The GRAPHIC EQUALIZER controls function in the playback mode only. They do not function when recording.
- If you remove your finger from the button, the indicator stops flashing after a few seconds and the Adjustment Mode is canceled. If this happens, press the button once more to select the Adjustment Mode.

⑯ DEMO button

Refer to the cover.

⑰ MULTI-ROOM indicator

Flashes when the signal is tuner control amplifier.

DISPLAY FACILITIES

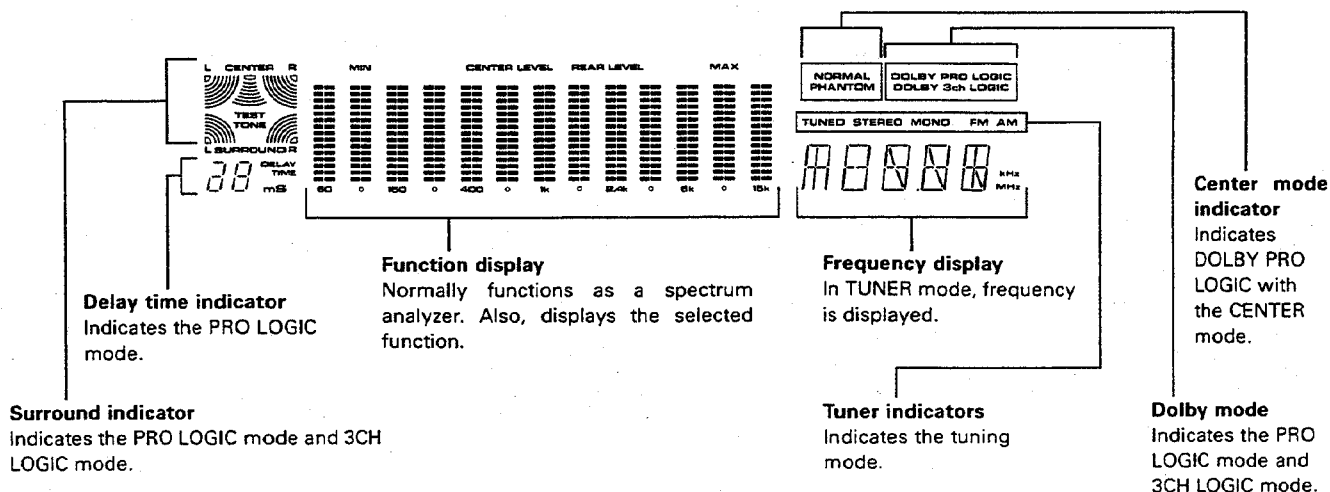

REMOTE CONTROL UNIT FACILITIES

[For CX-770 Remote Control Unit]

Range of remote control

When the remote control unit is pointed at the REMOTE SENSOR window on the tuner control amplifier and any of its buttons is pressed, the tuner control amplifier and other components can be operated by remote control.

Distance : Within a range of approx. 7 meters (23 feet) from the REMOTE SENSOR window.

Angle : Within approx. 30 degrees from the center of the REMOTE SENSOR window.

Remote control will not be possible if there is an obstacle between the remote control unit itself and the REMOTE SENSOR window. Performance of the remote control unit is adversely affected in the presence of a strong fluorescent light. Keep such lights away, especially from the sensor window.

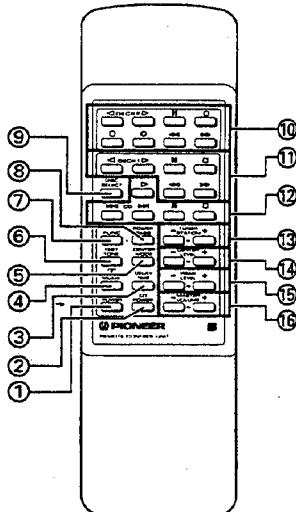
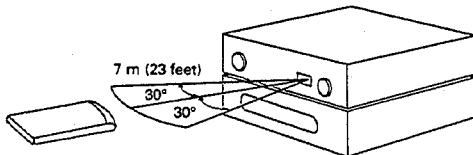

① AMP POWER button

When the power to tuner control amplifier is ON, you can switch power ON and OFF (Standby) with the POWER button on the remote control.

② CD POWER button

Switches CD player power ON/OFF. Refer to the CD player's operating instructions in detail.

③ DELAY TIME button

Use to select a delay time. The time changes in the following manner each time this button is pressed.

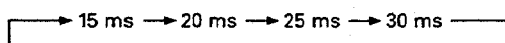

④ MODE button

Use to select a desired DOLBY mode position. The mode changes in the following manner each time this button is pressed.

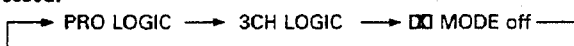

⑤ CENTER MODE button

Use to select between PHANTOM and NORMAL in order to set the correct surround center mode.

⑥ TEST TONE button

When the unit is in surround mode and the test tone button is pressed ON, a test tone sound will be output from each speaker in turn. Use this function to assist you when adjusting your equipment controls so that the volume from all channels is equal. This button is on remote control unit only.

⑦ FUNC (function) button

⑧ POWER BASS button

Use to switch the POWER BASS function ON/OFF (for emphasized bass sound).

⑨ DISC SELECT button

Used for disc selection on a multi-play CD player. Refer to the CD player's operating instructions in detail.

⑩ Cassette deck operation buttons (DECK II)

- ◀ DECK II ▶ : Selects forward/reverse playback.
- ⏸ : Pause (Stops temporarily.)
- : Stop (Stops tape transport.)
- ⏮ : REW (Rewinds the tape.)
- ⏭ : FF (Fast forward)
- : REC (Sets the recording mode.)
- : Rec Mute

Refer to the cassette deck's operating instructions in detail.

⑪ Cassette deck operation buttons (DECK I)

- ◀ DECK I ▶ : Selects forward/reverse playback.
- ⏸ : Pause (Stops temporarily.)
- : Stop (Stops tape transport.)
- ⏮ : REW (Rewinds the tape.)
- ⏭ : FF (Fast forward)

Refer to the cassette deck's operating instructions in detail.

⑫ CD operation buttons

- : Stop
- ⏸ : Pause
- ▶ : Playback
- ⏮, ⏭ : Track search

Refer to the CD player's operating instructions in detail.

⑬ TUNER STATION - (down), + (up) buttons

Before operation, memorize broadcast stations with the STATION CALL button.

- + Stations change in order in the upward direction.
- Stations change in order in the downward direction.

⑭ CENTER LEVEL - (down), + (up) buttons

Use these to independently adjust the center speaker system volume level for the optimum front-center volume balance. This button is on remote control unit only.

⑮ REAR LEVEL - (down), + (up) buttons

Use these to independently adjust the rear speaker system volume level for the optimum front-rear volume balance. This button is on remote control unit only.

⑯ MASTER VOLUME - (down), + (up) buttons

Increases/decreases the sound volume of the unit. When using these buttons, MASTER VOLUME indicator on the main unit flashes.

REMOTE CONTROL OF TUNER CONTROL AMPLIFIER

AUDIO VIDEO Set the AUDIO/VIDEO switch to AUDIO.



SURROUND function buttons:

DOLBY PRO LOGIC button:

Switches the DOLBY PRO LOGIC SURROUND function ON/OFF.

3CH LOGIC button:

Switches the 3CH LOGIC function ON/OFF.

TEST TONE button:

Used when DOLBY PRO LOGIC SURROUND, DOLBY 3CH LOGIC is in the on position. Used to adjust the test tone volume level from each speaker.

CENTER MODE button:

Set the DOLBY PRO LOGIC center mode to NORMAL/PHANTOM.

DELAY TIME button:

This functions as a DELAY TIME button. During DOLBY PRO LOGIC SURROUND operation, delay time settings can be changed from 15 ms to 30 ms in 5 ms steps. The DELAY TIME button does not operate in any other surround mode.

REAR LEVEL -/+ buttons:

This functions as a REAR LEVEL button. Adjust the sound level of the rear speakers.

CENTER LEVEL -/+ buttons:

This functions as a CENTER LEVEL button. Adjust the sound level of the center speaker.

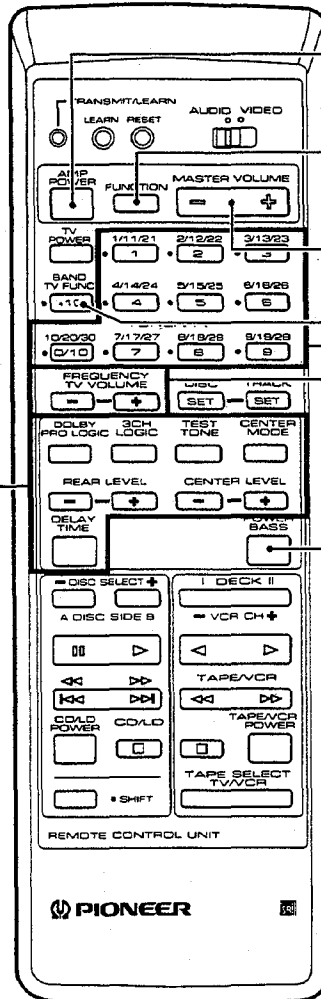

AMP POWER button:

Switches the tuner control amplifier power between ON and STANDBY.

FUNCTION button:

Used to change the tuner control amplifier function.

MASTER VOLUME -, + buttons:

Adjusts the overall volume.

BAND button:

Switches the FM and AM bands in turn.

1-30 (STATION CALL) buttons:

For direct tuning of stations stored in STATION CALL memory.

Each time you press any one of the buttons, the indications displayed at the top of the buttons change in sequence. (Example)

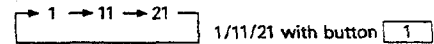

This lets you select desired numbers when specifying station channels.

FREQUENCY -, + buttons:

Shifts the frequency up (+) and down (-).

POWER BASS button:

Use to switch the POWER BASS function on and off. (For emphasized bass sound.)

1.3 SPECIFICATIONS

FM Tuner Section

Frequency Range	87.5 MHz to 108 MHz
Usable Sensitivity	19 dBf, IHF (2.4 μ V/75 Ω)
50 dB Quieting Sensitivity	Mono 25 dBf: (4.9 μ V/75 Ω)
Signal-to-Noise Ratio (IHF, 85 dBf Input)	Mono: 73 dB
Stereo Separation	35 dB (1 kHz)
Antenna Input	75 Ω unbalanced

AM Tuner Section

Frequency Range	530 kHz to 1,700 kHz
Sensitivity (IHF, Loop antenna)	800 μ V/m
Antenna	Loop Antenna

Miscellaneous

Dimensions	
CX-770/CX-770S	420 (W) x 140 (H) x 297 (D) mm
	16-9/16 (W) x 5-1/2 (H) x 11-11/16 (D) in
Weight (without package)	
CX-770/CX-770S	3.2 kg (7 lb 2 oz)

Accessories

FM Antenna	1
AM Loop Antenna	1
Operating Instructions	1
Remote Control Unit	
CX-770	1
CX-770S	1
Dry Cell Batteries	2
Warranty card	1

NOTE:

• Specifications and design are subject to possible modifications without notice due to improvements.

Manufactured under license from Dolby Laboratories Licensing Corporation. Additionally licensed under one or more of the following patents: U.S. number 3, 959, 590; Canadian numbers 1, 004, 603 and 1, 037, 877. "Dolby", "Pro Logic", and the double-D symbol are trademarks of Dolby Laboratories Licensing Corporation.

1.4 IC INFORMATION

■ PDG123A (DISPLAY ASSY IC301)

● CPU

● Pin Assignment

● The information shown in the list is basic information and may not correspond exactly to that shown in the schematic diagrams.

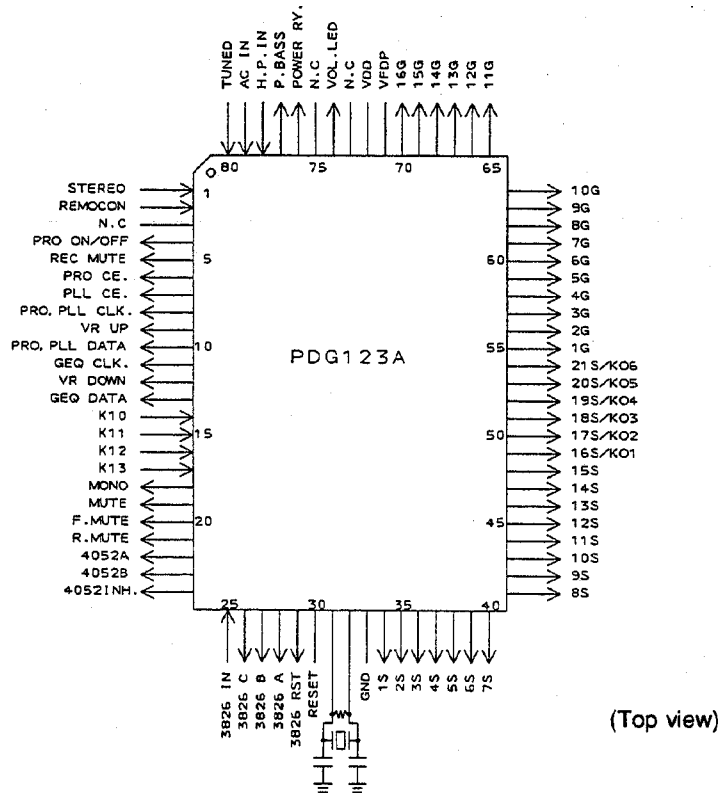

● Block Diagram

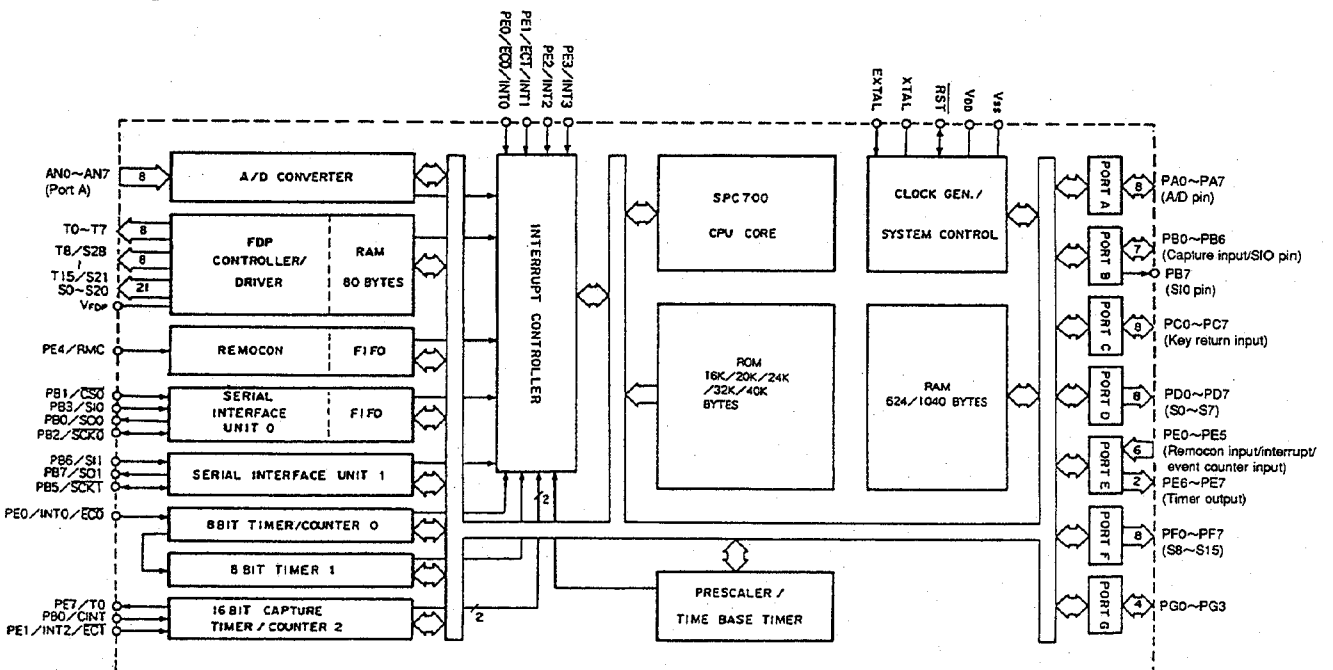

CX-770S, CX-770

● Pin function (PDG123A)

No.	Pin name	I/O	Function
1	STEREO	I	STEREO IN
2	REMOCON	I	REMOCON IN
3	NOT USED	I	PULL DOWN OR UP
4	PRO ON/OFF	O	PRO LOGIC ON/OFF
5	REC MUTE	O	REC MUTE
6	PRO CE	I/O	PRO LOGIC CE
7	PLL CE	I/O	PLL CE
8	PRO, PLL CL	I/O	PRO, PLL CLOCK
9	VR UP	I/O	VOLUME UP
10	PRO, PLL DA	I/O	PRO, PLL DATA
11	GEQ CLK	I/O	GEQ CLOCK
12	VR DOWN	I/O	VOLUME DOWN
13	GEQ DATA	O	GEQ DATA
14	KI0	I/O	KEY IN 0
15	KI1	I/O	KEY IN 1
16	KI2	I/O	KEY IN 2
17	KI3	I/O	KEY IN 3
18	MONO	I/O	MONO ON/OFF
19	MUTE	I/O	PLL MUTE
20	F. MUTE	I/O	FRONT MUTE
21	R. MUTE	I/O	REAR MUTE
22	4052A	I/O	4052 A
23	4052B	I/O	4052 B
24	4052 IHN	I/O	4052 INHIBIT
25	3826 IN	I/O	3826 IN
26	3826 C	I/O	3826 C
27	3826 B	I/O	3826 B
28	3826 A	I/O	3826 A
29	3826 RST	I/O	3826 RESET
30	RESET	I/O	RESET CONNECTION
31	EXTAL	I	8.00MHz OSCILLATOR CONNECTION
32	XTAL	—	8.00MHz OSCILLATOR CONNECTION
33	GND	—	GND
34	1S	O	1 SEG FL ANODE P14
35	2S	O	2 SEG FL ANODE P15
36	3S	O	3 SEG FL ANODE P16
37	4S	O	4 SEG FL ANODE P17
38	5S	O	5 SEG FL ANODE P18
39	6S	O	6 SEG FL ANODE P19
40	7S	O	7 SEG FL ANODE P20
41	8S	O	8 SEG FL ANODE P21
42	9S	O	9 SEG FL ANODE P22
43	10S	O	10 SEG FL ANODE P23
44	11S	O	11 SEG FL ANODE P13
45	12S	O	12 SEG FL ANODE P14

No.	Pin name	I/O	Function
46	13S	O	13 SEG FL ANODE P11
47	14S	O	14 SEG FL ANODE P10
48	15S	O	15 SEG FL ANODE P9
49	16S/K01	O	16 SEG FL ANODE P8/KEY OUT1
50	17S/K02	O	17 SEG FL ANODE P7/KEY OUT2
51	18S/K03	O	18 SEG FL ANODE P6/KEY OUT3
52	19S/K04	O	19 SEG FL ANODE P5/KEY OUT4
53	20S/K05	O	20 SEG FL ANODE P4
54	21S/K06	O	21 SEG FL ANODE P3
55	1G	O	1 GRED
56	2G	O	2 GRED
57	3G	O	3 GRED
58	4G	O	4 GRED
59	5G	O	5 GRED
60	6G	O	6 GRED
61	7G	O	7 GRED
62	8G	O	8 GRED
63	9G	O	9 GRED
64	10G	O	10 GRED
65	11G	O	11 GRED
66	12G	O	12 GRED
67	13G	O	13 GRED
68	14G	O	14 GRED
69	15G	O	15 GRED
70	16G	O	16 GRED
71	VFDP	—	VFDP
72	VDD	—	VDD
73	NOT USED	—	CONNECTED TO VDD
74	VOL LED	I/O	VOLUME LED
75	NOT USED	I/O	NOT USED
76	POWER RY.	I/O	POWER RELAY
77	P. BASS	I/O	P. BASS ON/OFF
78	H. P. IN	I	HEADPHON IN
79	AC IN	I	AC IN
80	TUNED	I	TUNED IN

1.6 ADJUSTMENTS

ADJUSTMENT OF THE FM TUNER SECTION

- Set the FM/AM selector to FM BAND.
- Connect the wiring as shown in the Fig.1.

Step No.	Adjustment Title	FM SG (1kHz, ±75kHz dev.)		Reception Frequency Display	Adjustment	
		Frequency (MHz)	Level (dB μ V)		Adjustment Location	Specifications
1	Center adjustment	98	80	98.0MHz	L6207	Adjust so that DC voltage between the IC6201-pin4 and pin 28(or \oplus leads of C6224 and C6261) becomes 0V \pm 50mV.
2	Front-end sensitivity adjustment	98	Low input (0 to 30)	98.0MHz	L6102 T6101	Adjust so that the DC voltage between the IC6201- pin12 and GND(or \oplus lead of C6238 and GND) becomes maximum level.
3	TUNED IND. Lighting level	98	15 (\pm 2dB)	98.0MHz	VR6201	Adjust so that the indicator of TUNED IND. starts to light up.

ADJUSTMENT OF MW TUNER SECTION

- Set the FM/AM selector to AM(MW)BAND.
- Connect the wiring as shown in the Fig.1.

Step No.	Adjustment Title	AM SG (400Hz, 30% Mod.)		Reception Frequency Display	Adjustment	
		Frequency (kHz)	Level (dB μ V/m)		Adjustment Location	Specifications
1	TUNED IND. Lighting level	1000	47(\pm 2dB)	1000kHz	VR6202	Adjust so that the indicator of TUNED IND. starts to light up.

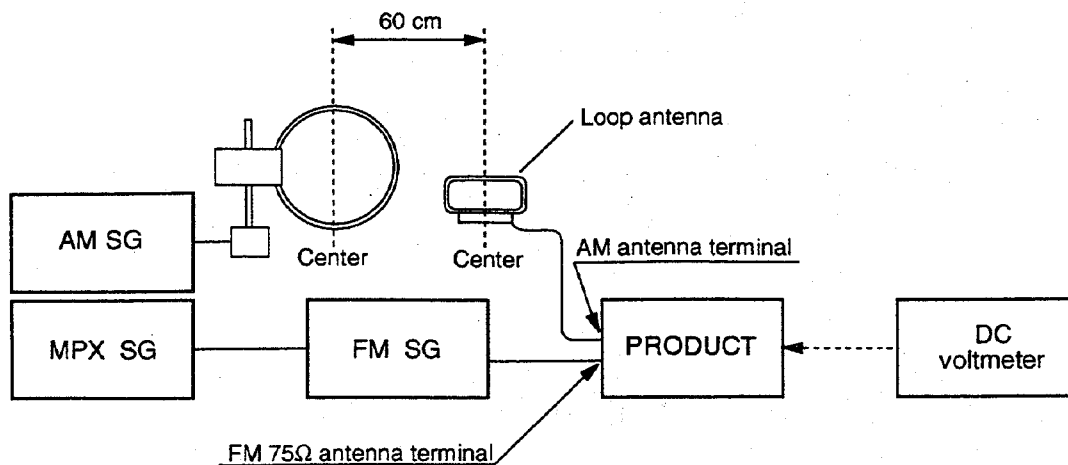

Fig. 1 AM and FM adjustment wiring diagram

FM/AM TUNER MODULE

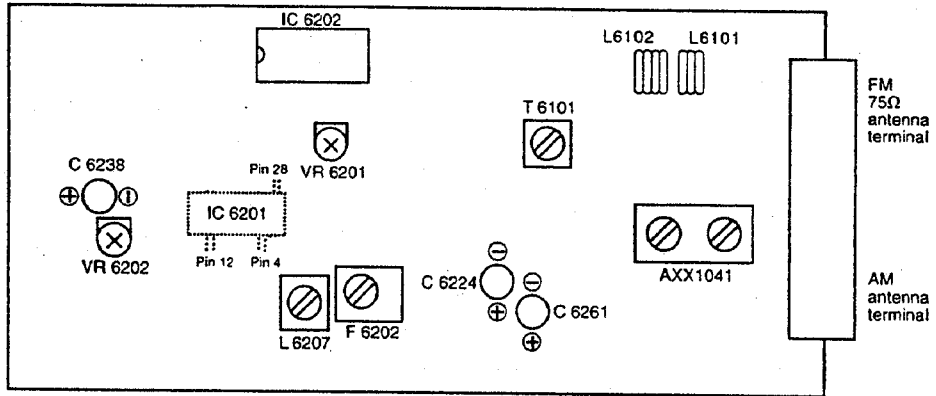

Fig. 2 Adjustment location

1.7 TROUBLESHOOTING

How to Repair CX-770 and CX-770S

As CX-770 and CX-770S are supplied with power from the various types of power supplies of M-770, please carry out repair in combination with M-770.

How to Repair CX-770 and CX-770S only.

When checking of the operation of only CX-770 and CX-770S is required the operation can be easily checked according the following procedures. (The FL display will not light.)

1. Short-circuit both edges of C303 on the DISPLAY ASSY (AWZ7290) and pull out the charge. (In order to erase the last memory)
2. Connect external power supplies, as shown below, to the TP terminal (P521 - P531) on the GEQ ASSY (AWZ7291).

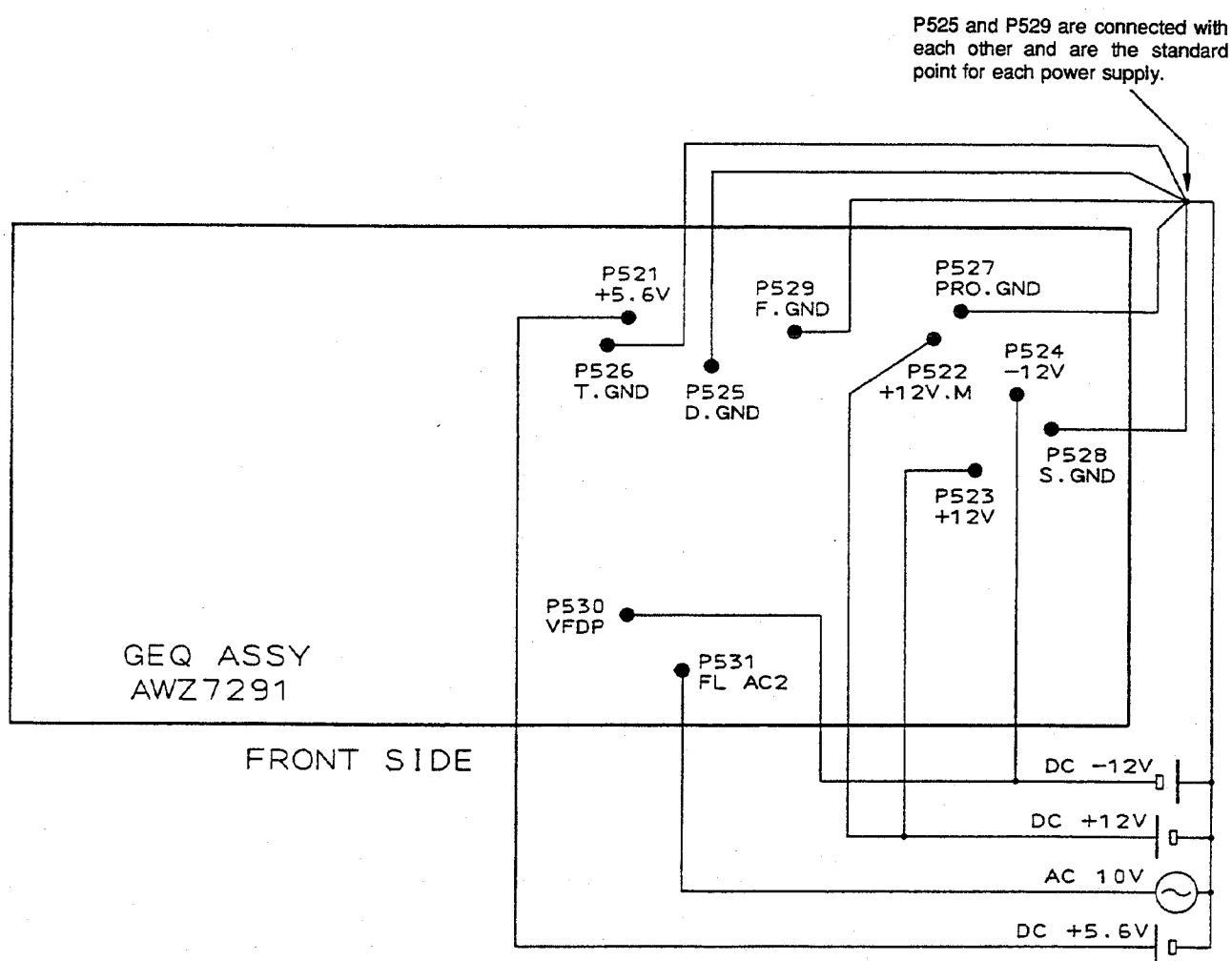

3. When supplying the various power supplies mentioned in 2 above, the standby LED will light and the standby function is activated.
4. When pressing the standby switch, the set will enter normal operation status (the standby LED goes out). However, the FL display will not light.
5. The set is set to the following initialization status.
 Input switching : Tuner (FM87.5MHz)
 DOLBY PRO LOGIC : OFF
 Graphic Equalizer : FLAT

After this, you can carry out the various required settings by the normal operation method and check the operation.

1.8 PARTS LIST FOR REMOTE CONTROL UNIT (CU-CX007)

1.8.1 PARTS LIST

NOTES :

- Parts marked by "NSP" are generally unavailable because they are not in our Master Spare Parts List.
- The Δ mark found on some component parts indicates the importance of the safety factor of the part. Therefore, when replacing, be sure to use parts of identical designation.
- Parts marked by "⊙" are not always kept in stock. Their delivery time may be longer than usual or they may be unavailable.

Parts List

Mark	No.	Description	Parts No.	Mark	No.	Description	Parts No.
	1	PLATE	AZA 7068		9	CASE (B)	AZN2255
	2	RUBBER SHEET (A) (S102)	AZA1985		10	BATTERY COVER	AZN2256
	3	RUBBER SHEET (B) (S103)	AZA 7069		11	FILTER	AZN2257
	4	TERMINAL	AZB1334		12	P. C. BOARD	AZN2258
	5	SCREW	AZB1335	NSP	13	KNOB (VIDEO/AUDIO)	AZN2259
	6	TERMINAL (A)	AZB1379		14	FRAME	AZN2260
	7	TERMINAL (B)	AZB1380		15	SLIDE SW (S101)	AZS1134
	8	CASE (A)	AZN7143				

1.8.2 PCB PARTS LIST

NOTES :

- Parts marked by "NSP" are generally unavailable because they are not in our Master Spare Parts List.
- The Δ mark found on some component parts indicates the importance of the safety factor of the part. Therefore, when replacing, be sure to use parts of identical designation.
- Parts marked by "⊙" are not always kept in stock. Their delivery time may be longer than usual or they may be unavailable.
- When ordering resistors, first convert resistance values into code form as shown in the following examples.

Ex. 1 When there are 2 effective digits (any digit apart from 0), such as 560 ohm and 47k ohm (tolerance is shown by J = 5%, and K = 10%).

560 Ω \rightarrow 56 \times 10¹ \rightarrow 561 RD1/8PM \square \square \square J
 47k Ω \rightarrow 47 \times 10³ \rightarrow 473 RD1/4PS \square \square \square J
 0.5 Ω \rightarrow 0R5 RN2H \square \square \square K
 1 Ω \rightarrow 010 RS1P \square \square \square K

Ex. 2 When there are 3 effective digits (such as in high precision metal film resistors).

5.62k Ω \rightarrow 562 \times 10¹ \rightarrow 5621 RM1/4PC \square \square \square \square F

Mark	No.	Description	Parts No.	Mark	No.	Description	Parts No.
SEMICONDUCTORS					C3	ELECT. CAPACITOR	CEAS0R1M50
	IC1	μ -COM	AZC7024		C4, 5	CERAMIC CAPACITOR	CCDSL330J50
	IC2	IC	PST9121N		C6	ELECT. CAPACITOR	CEAS101M10
	Q1	CHIP TRANSISTOR	2SC3265		C7	CERAMIC CAPACITOR	CCDSL101J50
	D1	LED	SE303A-C		C8	ELECT. CAPACITOR	CEAS0R1M50
	D2	CHIP DIODE	RLS73	RESISTORS			
	D3	DIODE	SPS-503C-3		R1	CARBON FILM RESISTOR	RD1/4PM020J
	D4, 5	CHIP DIODE	RLS73			Other resistors	RD1/8PM \square \square \square J
	D6	LED	SLC-22VR	OTHERS			
CAPACITORS					X1	RESONATOR	FCR4.0MC3
	C1	ELECT. CAPACITOR	CEAS221M25				
	C2	ELECT. CAPACITOR	CEAS101M10				

1.9 PARTS LIST FOR PACKING AND EXPLODED VIEWS

NOTES:

- Parts marked by "NSP" are generally unavailable because they are not in our Master Spare Parts List.
- The Δ mark found on some component parts indicates the importance of the safety factor of the part. Therefore, when replacing, be sure to use parts of identical designation.
- Parts marked by "⊙" are not always kept in stock. Their delivery time may be longer than usual or they may be unavailable.

(1) CONTRAST OF CX-770S/ZU, CX-770S/ZC AND CX-770/ZU

• CX-770S/ZU, CX-770S/ZC AND CX-770/ZU have the same construction except for the following :

Mark	No.	Symbol & Description	Part No.		
			CX-770S/ZU	CX-770S/ZC	CX-770/ZU
	12	Front panel	AMB7094	AMB7094	AMB7091
	38	Packing case	AHD7061	AHD7061	AHD7057
	31	Remote control unit (CU-CX007)	AXD7023	AXD7023	Not used
	31	Remote control unit (CU-CX006)	Not used	Not used	AXD7022
	32	Battery cover	*1	*1	AZA7028
NSP	33	Alkaline (LR03, AAA)	AEX1006	AEX1006	Not used
NSP	33	Battery (R6P, AA)	Not used	Not used	AEX-010

Note *1 : Refer to "1.8 PARTS LIST FOR REMOTE CONTROL UNIT (CU-CX007)".

(2) PARTS LIST FOR CX-770S/ZU

Mark	No.	Description	Parts No.	Mark	No.	Description	Parts No.
NSP	1	CHASSIS(MET)	ANA7012		31	REMOTE CONTROL UNIT (CU-CX007)	AXD7023
	2	INSULATOR	PNW1912		32	
	3	INSULATOR ASSY	DXA1490		33	ALKALINE (LR03, AAA)	AEX1006
NSP	4	PCB MOULD	AMR1525		34	LOOP ANTENNA	ATB1012
	5	REAR PANEL	ANC7130		35	FM ANTENNA	ADH1017
	6	GEQ ASSY	AWZ7291		36	SIDE PAD NO.1	AHA7022
	7	PCB SUPPORT	AEC1581		37	SIDE PAD NO.2	AHA7023
	8	CORD WITH PLUG	ADE7002		38	PACKING CASE	AHD7061
	9	FM/AM TUNER MODULE	AXQ1012		39	LITERATURE BAG	AHG-117
	10	DOL. PRO. MOD. ASSY	AXQ1021	NSP	40	PACKING SHEET	AHG7008
	11	VR ASSY	AWZ7292		41	SCREW	ABA-222
	12	FRONT PANEL	AMB7094		42	SCREW	VPZ30P080FZK
	13	FUNCTION BUTTON	AAD7059				
	14	TUNER BUTTON	AAD7061				
	15	GEQ. BUTTON	AAD7060				
	16	POWER BUTTON	AAD7062				
	17	BASS BUTTON	AAD7063				
	18	DISPLAY ASSY	AWZ7290				
	19	FLEXIBLE CABLE	ADD1099				
	20	VOL. KNOB	AAB7025				
	21	VOL. KNOB LENZ	AAK7074				
	22	BASS LEV. KNOB	AAB7024				
	23	DISPLAY PANEL	AAK7073				
	24	ROUND KNOB	AAB2226				
	25	NAME PLATE	PAM1608				
	26	BONNET CASE	ANE7032				
	27	SCREW	ABA1018				
	28	SCREW	BBZ30P080FZK				
	29	SCREW	BPZ26P080FMC				
	30	SCREW	BBT30P080FZK				

1.10 PCB PARTS LIST

NOTES:

- Parts marked by "NSP" are generally unavailable because they are not in our Master Spare Parts List.
- The Δ mark found on some component parts indicates the importance of the safety factor of the part. Therefore, when replacing, be sure to use parts of identical designation.
- Parts marked by "⊙" are not always kept in stock. Their delivery time may be longer than usual or they may be unavailable.
- When ordering resistors, first convert resistance values into code form as shown in the following examples.

Ex.1 When there are 2 effective digits (any digit apart from 0), such as 560 ohm and 47k ohm (tolerance is shown by J = 5%, and K = 10%).

560Ω	→	56 × 10 ¹	→	561	RD1/8PM	561 J
47kΩ	→	47 × 10 ³	→	473	RD1/4PS	473 J
0.5Ω	→	0R5			RN2H	0R5 K
1Ω	→	010			RS1P	010 K

Ex.2 When there are 3 effective digits (such as in high precision metal film resistors).

5.62kΩ	→	562 × 10 ¹	→	5621	RN1/4PC	5621 F
--------	---	-----------------------	---	------	-------	---------	--

Mark No.	Description	Parts No.	Mark No.	Description	Parts No.
LIST OF ASSEMBLIES			C302,C304		CKPUYF473Z16
NSP	FUKUGOU ASSY	AWM7097	RESISTORS		
	└─ DISPLAY ASSY	AWZ7290	R321		RA10S104J
	└─ GEQ ASSY	AWZ7291	R322		RA12S104J
	└─ VR ASSY	AWZ7292	R320		RA8S104J
			R323		RA9S104J
	FM/AM TUNER MODULE	AXQ1012	R380,R387,R390,R397		RD1/4PM221J
	DOL.PRO.MOD. ASSY	AXQ1021			
			R373		RD1/4PM270J
			VR301 (100kΩB)		ACS1102
			VR302 (10kΩB)		ACS1104
			Other Resistors		RD1/8PM □□□ J
			OTHERS		
			V301	FL TUBE	AAV7007
			CN301	40P SOCKET	AKP1085
			X301	CERAMIC RESONATOR(8.00MHz)	ASS1015
				REMOTE RECEIVER UNIT	AXX1023
	DISPLAY ASSY		GEQ ASSY		
	SEMICONDUCTORS		SEMICONDUCTORS		
	IC301	PDG123A	IC551,IC552		LA3607
	IC302	XRA3826S	IC553		LC7522
	Q301,Q305,Q306,Q320	2SC2458	IC502		MC14052BCP
	Q375	XDA124ES	IC504,IC505		MC14066BCP
	Q303	XDA143ES	IC501,IC503		NJM4558DXP
	Q302,Q372,Q374	XDC124ES	Q652		2SA1515
	Q304,Q371	XDC143ES	Q670		2SB1274
	D307,D371	AEL1065	Q671,Q672		2SC2878
	D314	AEL1084	Q651		2SC3377
	D301,D302,D305,D306	HSS104-02	Q501,Q502,Q504-Q507,Q673		XDA124ES
	D309,D310,D331-D336	HSS104-02	Q503		XDC124ES
	D372-D384	HSS104-02	D501,D601-D604,D660,D661		HSS104-02
			D672		HSS104-02
			D680		RD3.3ESB2
			D673		RD36ESB3
			D679		RD4.3ESB3
			D651,D652		RD5.6ESB2
			D670,D671		S5688G
	COILS AND FILTERS				
	L302	ATX1008			
	L301	LAU220J			
	SWITCHES AND RELAYS				
	S301-S321	ASG1034			
	CAPACITORS				
	C303	ACH1246			
	C307,C315	CCCSL101J50			
	C301	CEAS010M50			
	C312,C332	CEAS100M50			
	C305,C314	CEAS221M10			
	C371	CEASR47M50			
	C331,C333	CKCYF103Z50			
	C311	CKCYF223Z50			
	C306,C320-C322	CKCYF473Z50			
	C313	CKCYX104M25			

CX-770S, CX-770

Mark No.	Description	Parts No.	Mark No.	Description	Parts No.
COILS AND FILTERS			COILS AND FILTERS		
L651, L652		LAU470J	IC401		M5220P
CAPACITORS			Q450, Q451		2SC2458
C602		CEAS010M50	Q402, Q403, Q405, Q406, Q432		2SC2878
C519, C520		CEAS100M50	Q431		XDA124ES
C565, C566		CEAS101M10	Q433		XDC124ES
C676		CEAS101M50			
C671		CEAS101M63	D401, D402		HSS104-02
C674, C675		CEAS102M50	COILS AND FILTERS		
C513, C514		CEAS220M16	L401		LAU221K
C677, C678		CEAS220M50	CAPACITORS		
C670		CEAS221M63	C439		CCCCH101J50
C561 - C564		CEAS2R2M50	C492, C493		CCCSL220J50
C507, C508		CEAS330M50	C413, C414		CCDSL470J50
C515, C516		CEAS470M16	C403, C404, C440, C442, C444, C457, C458		CEAS100M50
C672, C673		CEAS470M50	C453, C454, C480		CEAS100M50
C567, C568, C573, C574		CEAS470M50			
C569, C570		CEASR15M50	C431, C432		CEAS101M10
C587, C588		CEASR47M50	C472		CEAS101M25
C659		CEEA100M50	C443		CEAS220M16
C575, C576, C581, C582		CFTXA184J50	C437, C438		CEAS3R3M50
C571, C572, C577, C578		CFTXA273J50	C445		CEASR15M50
C551, C552, C557, C558		CFTXA683J50			
C579, C580, C585, C586		CGMYB182M50	C407, C408, C461, C462		CEYA100M50
C553, C554, C583, C584		CGMYX103M16	C435, C436		CKCYB102K50
C651, C652		CGMYX472M25	C411, C412, C459, C460		CKCYB103K50
C490, C491		CKCYB102K50	C441		CKCYB222K50
C509, C510		CKCYB103K50	C455, C456		CKCYF223Z50
C559, C560		CKCYB152K50			
C511, C512		CKCYB331K50	C309, C310		CKCYX103M25
C518, C522		CKCYB562K50	C473		CKCYX104M25
C517, C521		CKCYF223Z50	C433, C434		CKCYX683M25
C555, C556		CKCYF473Z50	RESISTORS		
C655 - C658, C660		CKMYB681K50	VR401		ACX7001
		CKPUYF473Z16	Other Resistors		
RESISTORS			RESISTORS		
R671		RD1/2PM622J	Other Resistors		
R557, R558		RD1/4PM101J	RD1/8PM□□□J		
R670		RD1/4PM4R7J	FM/AM TUNER MODULE		
R679		RFA1/4PS100J	SEMICONDUCTORS		
R661, R662		RFA1/4PS4R7J	IC6201		LA1836M
R673, R674		RSILMF470J	IC6202		LM7001J
Other Resistors			Q6102		2SC2223
RD1/8PM□□□J			Q6203		2SC2235
OTHERS			Q6202		2SC2712
PIN JACK 6P (TAPE, LD/VCR)	AKB1121		Q6103, Q6214		2SC2714
PIN JACK 4P (PHONO, CD)	AKB1124		Q6201		2SK208
CN8209 JACK 2P (CONTROL)	AKN-209		Q6104		2SK302
JACK (REMOTE IN)	AKN1020		Q6101		3SK194
CN501 40P SOCKET	AKP1085		Q6204		XDA124EK
CN504 CONNECTOR 19P	AKP7002		Q6217		XDC124EK
VR ASSY			D6101, D6102		1T33
SEMICONDUCTORS			COILS AND FILTERS		
IC431, IC432		NJM4558DXP	L6104		ATC1003
IC403		TA8409S	L6101		ATC1020
IC402, IC481		UPC4570C	L6102		ATC1021
			T6101		ATE-063
			L6207 (10.7MHz)		ATE1013
			F6203, F6204		ATF-119
			F6101		ATF-155
			F6202		ATF1155
			L6103		ATH1043
			L6202, L6203, L6208		LCTA2R2J3225

Mark No.	Description	Parts No.	Mark No.	Description	Parts No.
CAPACITORS			AM FM TUNING BLOCK		
C6202,C6234,C6236 (1μF/16V)		ACG1051			AXX1041
C6235 (0.47μF/25V)		ACG1052	DOL.PRO.MOD. ASSY		
C6107		CCSCH010C50	SEMICONDUCTORS		
C6229		CCSCH821J50	IC1804		LA2785
C6110		CCSQCH020C50	IC1803		LV1010N
C6101		CCSQCH050C50	IC1801,IC1802		NJM4558M-D
C6108,C6203,C6268		CCSQCH101J50	Q1801		2SD468
C6111,C6116,C6208,C6221,C6222		CCSQCH150J50	D1802-D1810		1SS226
C6115		CCSQCH330J50			
C6114		CCSQRH080D50	D1801		RD10MB
C6113		CCSQRH180J50	CAPACITORS		
C6105		CCSQTH150J50	C1864,C1865 (100μF/25V)		ACH1262
C6261		CEAS010M50	C1852,C1853 (10μF/50V)		ACH1270
C6224,C6246,C6262		CEAS100M50	C1801-C1803		CCSQCH101J50
C6216,C6217		CEAS330M16	C1842,C1861		CEANL3R3M50
C6231,C6233		CEAS3R3M50	C1838,C1840,C1857,C1859		CEANL4R7M50
C6219		CEAS470M10	C1823,C1867-C1869		CEAS010M50
C6243-C6245		CEAS470M16	C1806,C1809,C1812,C1815,C1826		CEAS100M50
C6227		CEAS470M25	C1831-C1833,C1847-C1850		CEAS100M50
C6238		CEJA100M16	C1805,C1808,C1811,C1814		CEAS220M16
C6249,C6250		CEJA4R7M35	C1819		CEAS221M10
C6215		CFTXA103J50	C1817,C1824,C1846,C1851		CEAS221M16
C6214		CFTXA224J50	C1804,C1807,C1810,C1813,C1825		CEAS2R2M50
C6103,C6106,C6112,C6204		CKSQYB102K50	C1834		CEAS470M10
C6102,C6109,C6117,C6210,C6264		CKSQYB103K50	C1816		CEAS470M16
C6213		CKSQYB223K50	C1841,C1860		CEASR15M50
C6230		CKSQYB333K50	C1837,C1839,C1856,C1858		CEASR47M50
C6228,C6252		CKSQYB472K50	C1835,C1836,C1854,C1855		CFTYA104J50
C6209,C6237,C6265,C6267		CKSQYB473K50	C1843,C1862		CFTYA154J50
C6212,C6218		CKSQYF103Z50	C1820,C1822		CFTYA333J50
C6220,C6226,C6239,C6242,C6255		CKSQYF223Z50	C1863		CFTYA474J50
C6225,C6241,C6266		CKSQYF473Z50	C1818,C1866,C1870		CKSQYF104Z50
C6232		CKSYB333K50	C1821		CQMA152J50
C6251		CKSYB472K50	C1844		CQMA223J50
C6223		CKSYF103Z50	C1845		CQMA473J50
C6263		CKSYF473Z50	C1830		CQMA681J50
RESISTORS			RESISTORS		
R6299,R6300		RD1/8PM102J	All Resistors		RS1/10S□□□J
R6113,R6116,R6118,R6268-R6271		RS1/8 S000J	OTHERS		
R6275,R6276,R6278,R6283,R6284		RS1/8 S000J	X1801	CERAMIC RESONATOR(F=8.00MHz)	ASS1015
R6290,R6293,R6294,R6297		RS1/8 S000J	CN1801	SOCKET 15P	KP200IB15L
R6243,R6244		RS1/8 S101J			
R6211		RS1/8 S103J			
R6237		RS1/8 S182J			
R6209		RS1/8 S221J			
R6239		RS1/8 S332J			
R6101		RS1/8 S470J			
YR6201 (10kΩ)		ACP1056			
YR6202		VRTB6VS223			
Other Resistors		RS1/10S□□□J			
OTHERS					
BN6201	TERMINAL 4P	AKA1016			
X6203	CRYSTAL RESONATOR(F=7.200MHz)	ASS1042			
X6201	CRYSTAL RESONATOR(F=456kHz)	ASS1066			
X6202	CERAMIC RESONATOR(F=450kHz)	ATF1027			

Service Manual

ORDER NO.
RRZ1148

The chapter 1 of this Service Manual will not be reprinted. On your additional orders, we may supply only the chapter 2. For the chapter 1, please make copies and attach to the chapter 2 at your side if necessary.

STEREO TUNER CONTROL AMPLIFIER

CX-770S

CX-770

CHAPTER 2

CONTENTS

CHAPTER 2

2.1 PACKING AND EXPLODED VIEWS ...	2-3
2.2 SCHEMATIC AND PCB CONNECTION DIAGRAMS	2-6
2.3 BLOCK DIAGRAM	2-33
2.4 REMOTE CONTROL UNIT (CU-CX007)	2-35

2.1 PACKING AND EXPLODED VIEWS

● EXTERIOR

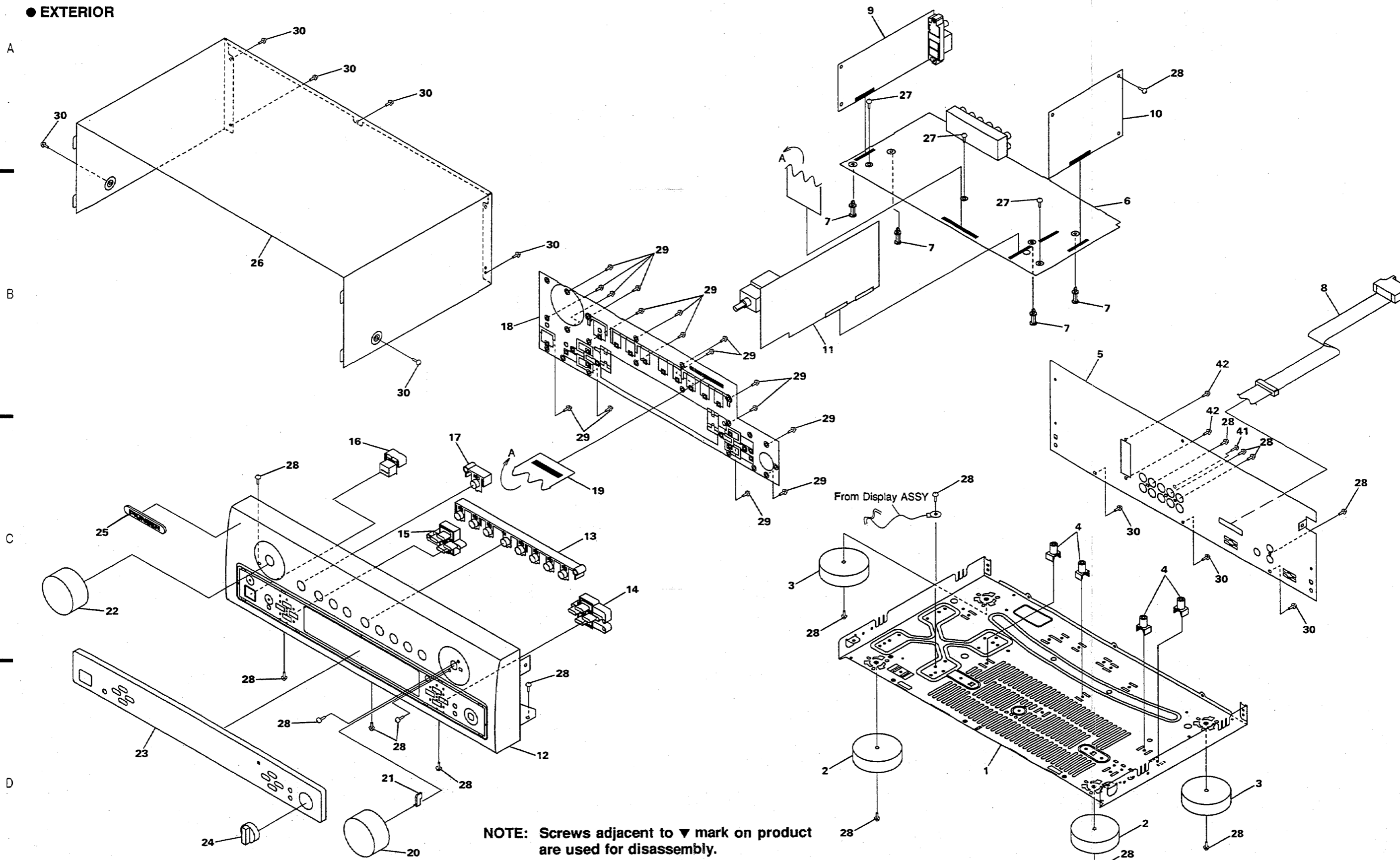

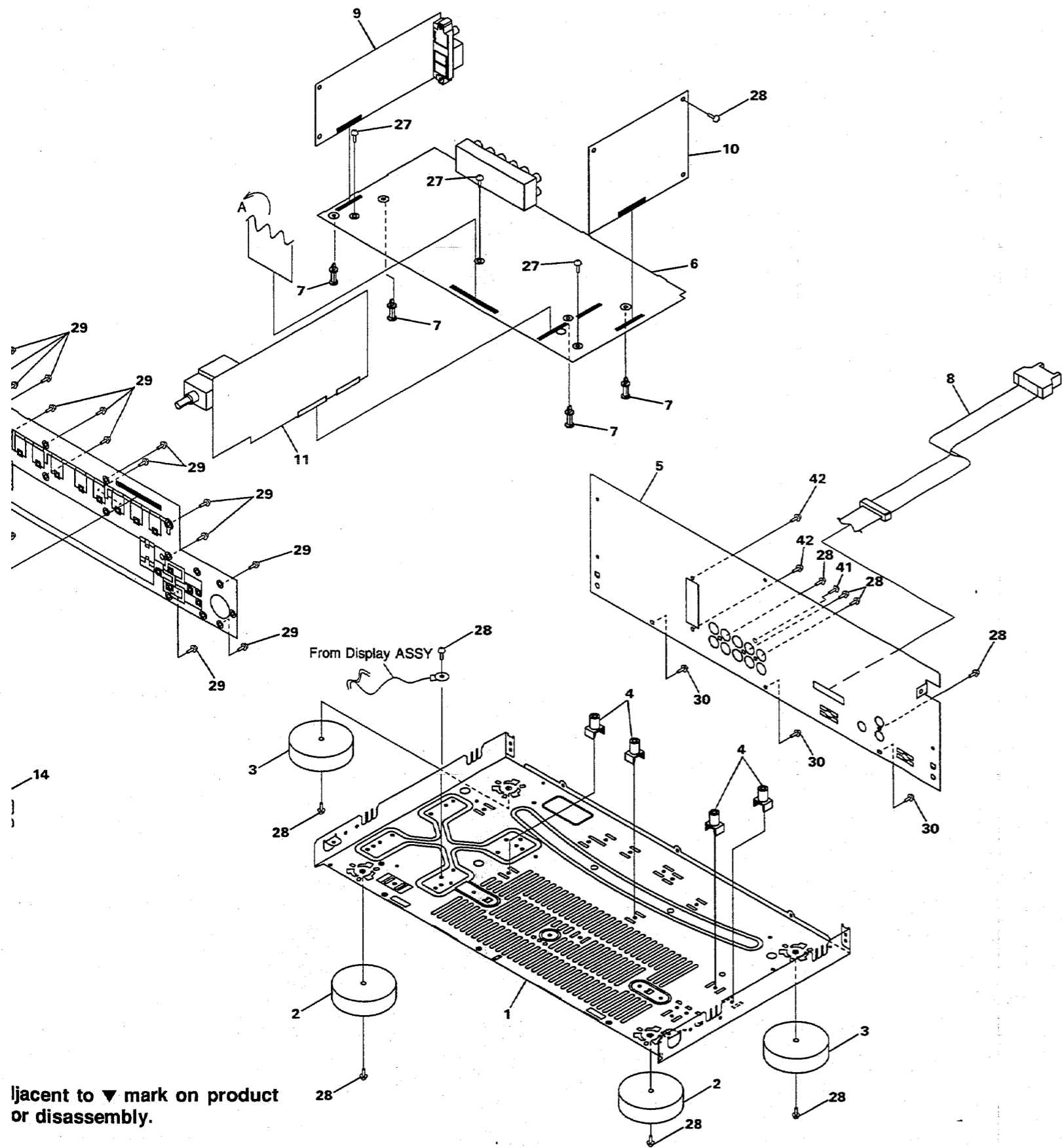

● PACKING

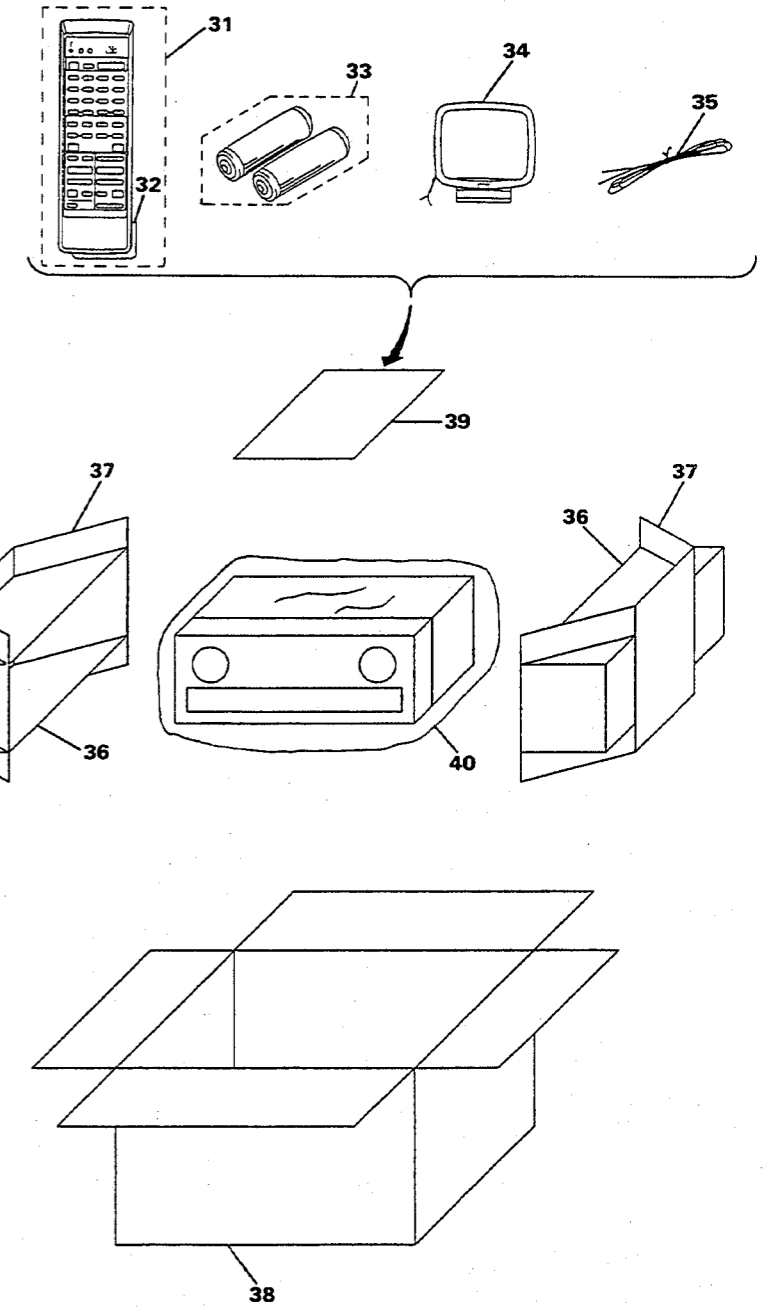
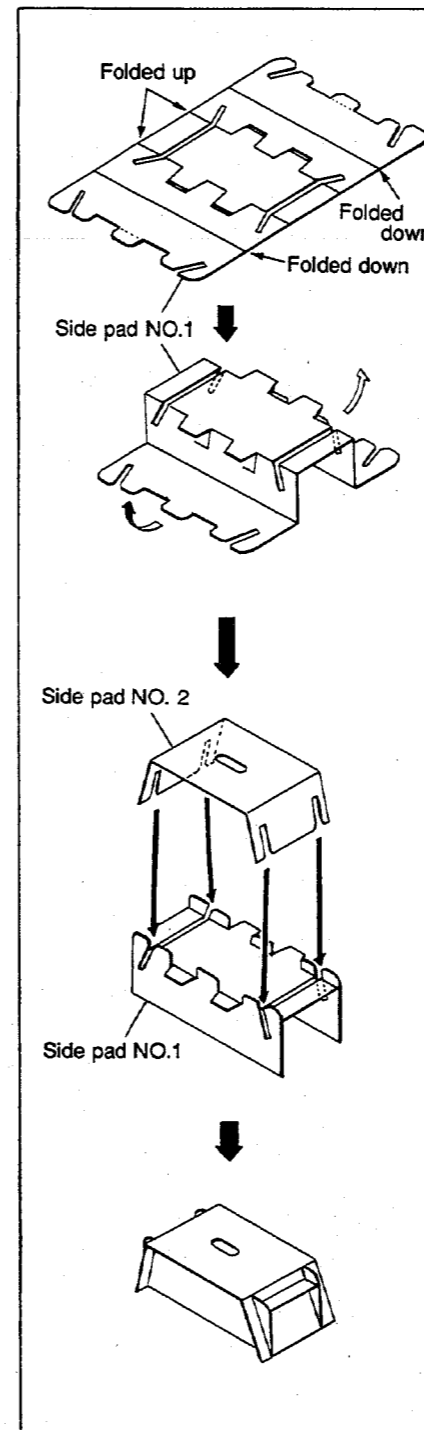

2.2 SCHEMATIC AND PCB CONNECTION DIAGRAMS

2.2.1 OVERALL CONNECTION DIAGRAM

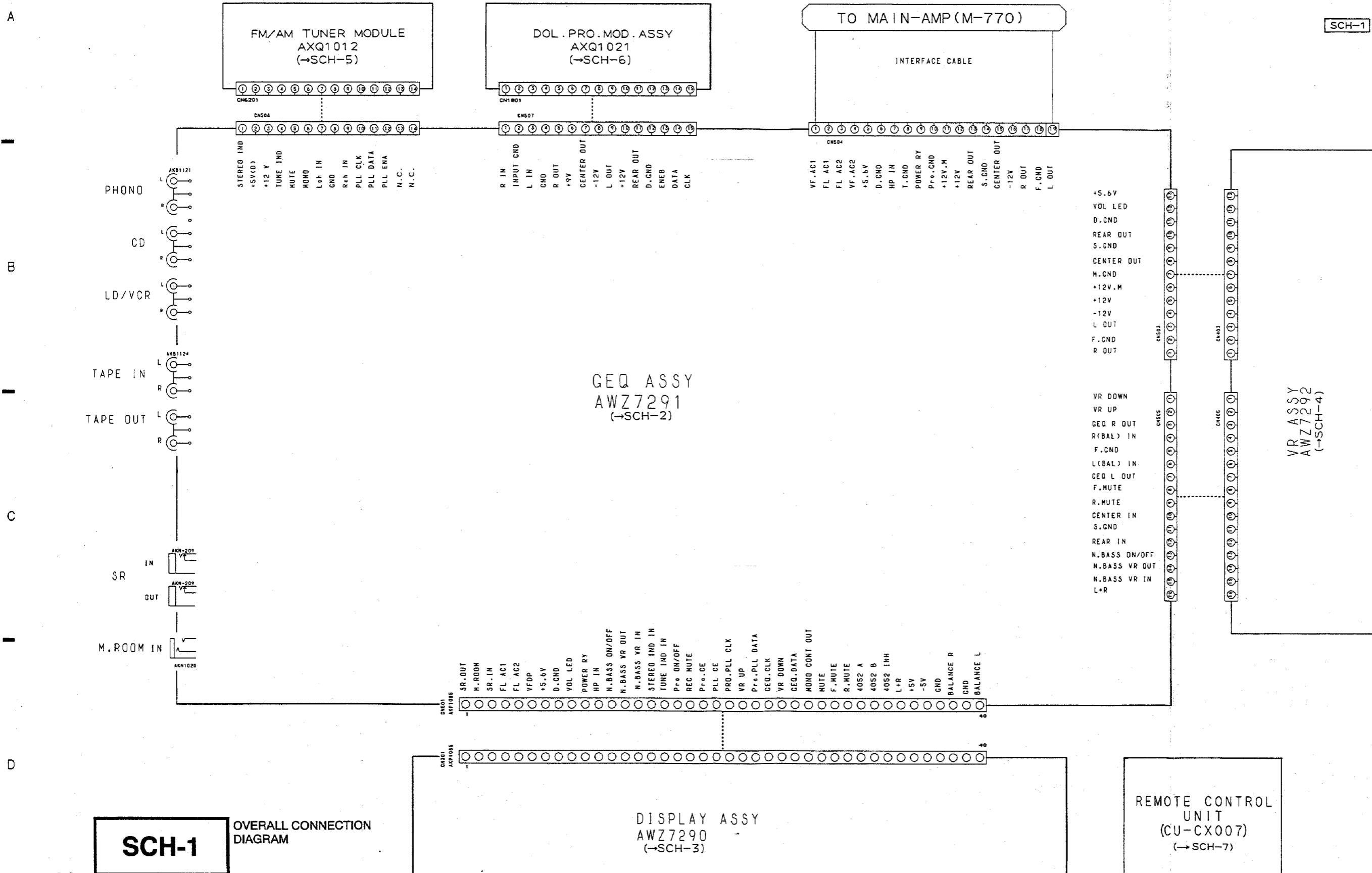

- NOTE FOR SCH**
- When ordering "PARTS LIST" or "PARTS LIST".
 - Since these are values of some ment.
 - RESISTORS:**
Unit: k:kΩ, M:MΩ
Rated power: 1/4W
Tolerance: (F): ± 1%
less otherwise noted.
 - CAPACITORS:**
Unit: p:pF or μ:μF
Rated voltage: 50V
Rated voltage: 50V
 - COILS:**
Unit: m:mH or μ:μH
 - VOLTAGE AND CURRENT:**
□ or - V : DC voltage
◊ or - mA : DC current
 - OTHERS:**
• ⊗ or ⊙ : Adjust
• ◀ : Measure
• The Δ mark for importance of the placing, be sure.
 - SCH-□ ON THE PARTS LIST:**
• SCH-□ indicates the location of the component in the schematic diagram. (SCH stands for Schematic)
 - SWITCHES (Under DISPLAY ASSY):**
S301 : ST/FRE
S302 : LD/VCR
S303 : MEMORY
S304 : FREQUENCY
S305 : DOLBY
S306 : TUNING
S307 : TUNING
S308 : MONO
S309 : EQUALIZER
S310 : CENTER
S311 : FM/AM
S312 : TAPE
S313 : CD
S314 : DEMO
S315 : EQUALIZER
S316 : DELAY
S317 : TUNING
S318 : PHONO
S319 : POWER
S320 : FREQUENCY
S321 : POWER

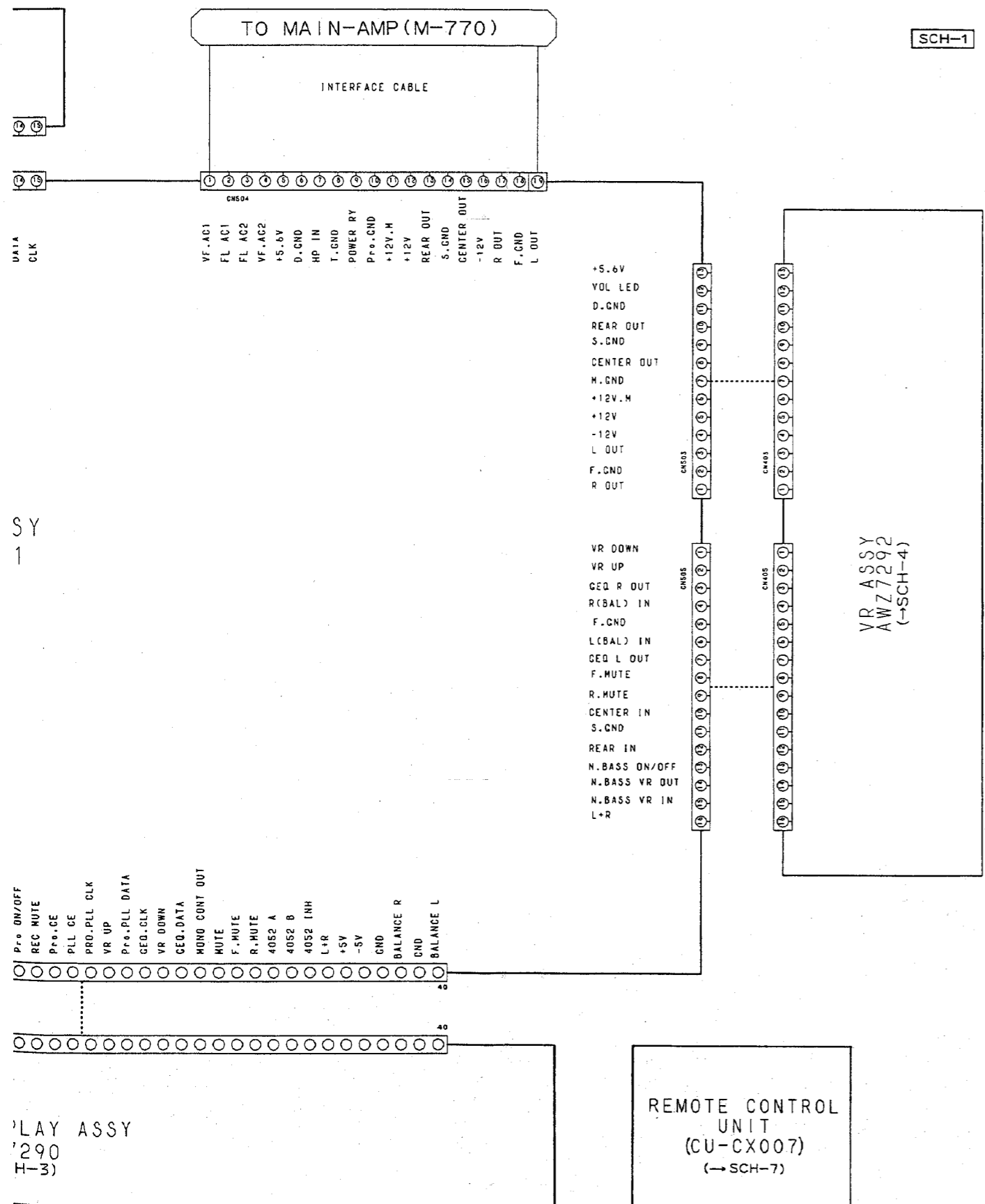

NOTE FOR SCHEMATIC DIAGRAMS (Type 2A)

- When ordering service parts, be sure to refer to "PARTS LIST of EXPLODED VIEWS" or "PCB PARTS LIST".**
- Since these are basic circuits, some parts of them or the values of some components may be changed for improvement.
- RESISTORS:**
Unit: k:kΩ, M:MΩ, or Ω unless otherwise noted.
Rated power: 1/4W, 1/6W, 1/8W, 1/10W unless otherwise noted.
Tolerance: (F): ±1%, (G): ±2%, (K): ±10%, (M): ±20% or ±5% unless otherwise noted.
- CAPACITORS:**
Unit: p:pF or μF unless otherwise noted.
Ratings: capacitor (μF)/ voltage (V) unless otherwise noted.
Rated voltage: 50V except for electrolytic capacitors.
- COILS:**
Unit: m:mH or μH unless otherwise noted.
- VOLTAGE AND CURRENT:**
□ or - V : DC voltage (V) at no input signal unless otherwise noted.
↺ mA or - mA : DC current at no input signal unless otherwise noted.
- OTHERS:**
 - ⊙ or ● : Adjusting point.
 - ◀ : Measurement point.
 - The Δ mark found on some component parts indicates the importance of the safety factor of the parts. Therefore, when replacing, be sure to use parts of identical designation.
- SCH-□ ON THE SCHEMATIC DIAGRAM:**
 - SCH-□ indicates the drawing number of the schematic diagram. (SCH stands for schematic diagram.)
- SWITCHES (Underline indicates switch position):**
DISPLAY ASSY
S301 : ST/FREQ
S302 : LD/VCR
S303 : MEMORY
S304 : FREQUENCY(◁)
S305 : DOLBY MODE
S306 : TUNING (-)
S307 : TUNER
S308 : MONO
S309 : EQUALIZING (-)
S310 : CENTER
S311 : FM/AM
S312 : TAPE
S313 : CD
S314 : DEMO
S315 : EQUALIZING (+)
S316 : DELAY TIME
S317 : TUNING (+)
S318 : PHONO
S319 : POWER (STANDBY/ON)
S320 : FREQUENCY(▷)
S321 : POWER BASS

NOTE FOR PCB DIAGRAMS:

- Part numbers in PCB diagrams match those in the schematic diagrams.
- A comparison between the main parts of PCB and schematic diagrams is shown below.

Symbol in PCB Diagrams	Symbol in Schematic Diagrams	Part Name
		Transistor
		Diode
		Capacitor (Polarized)

- The transistor terminal marked with E or ◻ shows the emitter.
- The diode terminal marked with ⊙ or ◻ shows cathode side.
- The capacitor terminal marked with ⊙ or ◻ shows negative terminal.

OVERALL CONNECTION DIAGRAM **SCH-1**

Service Manual

 **PIONEER**
The Art of Entertainment



PION - 04823

ORDER NO.
RRV1413

STEREO TUNER CONTROL AMPLIFIER

CX-770

CX-770S

- Refer to the service manual RRV1148 for CX-770S/ZU.

THIS MANUAL IS APPLICABLE TO THE FOLLOWING MODEL(S) AND TYPE(S).

Type	Model		Power Requirement	Remarks
	CX-770	CX-770S		
ZUXJ	○	○	DC power supplied from other system component	
ZCXJ	—	○	DC power supplied from other system component	

- This product is a component of a system.
For instruction manual, refer to the service manual RRV1166 for M-770.
- This product does not function properly when independent; to avoid malfunctions, be sure to connect it to the prescribed system component(s), otherwise damage may result.
- The "S" at the end of the model number indicates that a programmable remote control unit is supplied.

PIONEER ELECTRONIC CORPORATION

4-1, Meguro 1-Chome, Meguro-ku, Tokyo 153, Japan

PIONEER ELECTRONICS SERVICE, INC. P.O.Box 1760, Long Beach, CA 90801-1760, U.S.A.

PIONEER ELECTRONIC [EUROPE] N.V. Haven 1087, Keetberglaan 1, 9120 Melsele, Belgium

PIONEER ELECTRONICS ASIACENTRE PTE. LTD. 501 Orchard Road, #10-00 Lane Crawford Place, Singapore 0923

© PIONEER ELECTRONIC CORPORATION 1995

T-FZK OCT. 1995 Printed in Japan

4823

CX-770, CX-770S

● CONTRAST OF MISCELLANEOUS PARTS

NOTES:

- Parts marked by "NSP" are generally unavailable because they are not in our Master Spare Parts List.
- The Δ mark found on some component parts indicates the importance of the safety factor of the part. Therefore, when replacing, be sure to use parts of identical designation.
- Parts marked by "●" are not always kept in stock. Their delivery time may be longer than usual or they may be unavailable.

CX-770/ZUXJ, CX-770S/ZUXJ, CX-770S/ZCXJ and CX-770S/ZU have the same construction except for the following:

Mark	Symbol & Description	Part No.				Remarks
		CX-770S/ZU	CX-770/ZUXJ	CX-770S/ZUXJ	CX-770S/ZCXJ	
	Side pad No.1	AHA7022	Not used	Not used	Not used	For Packing For Packing
	Side pad No.2	AHA7023	Not used	Not used	Not used	
	Front pad	Not used	AHA1665	AHA1665	AHA1665	
	Rear pad	Not used	AHA1666	AHA1666	AHA1666	
	Packing case	AHD7061	RHG1699	RHG1700	RHG1700	
	Remote control unit (CU-CX007)	AXD7023	Not used	AXD7023	AXD7023	
	Remote control unit (CU-CX006)	Not used	AXD7022	Not used	Not used	
	Battery cover	AZN2256	AZA7028	AZN2256	AZN2256	
NSP	Alkaline (LR03, AAA)	AEX1006	Not used	PEM1005	PEM1005	
NSP	Battery (R6P, AA)	Not used	VEM-013	Not used	Not used	
NSP	Loop antenna	ATB1012	ATB7004	ATB7004	ATB7004	
	Chassis	ANA7012	ANA1228	ANA1228	ANA1228	
	Rear panel	ANC7130	RNA2019	RNA2019	RNA2019	
NSP	PCB mould	AMR1525	Not used	Not used	Not used	
	PCB mould	Not used	AMR2533	AMR2533	AMR2533	
	FM/AM TUNER module	AXQ1012	AXQ3112	AXQ3112	AXQ3112	
	DOL. PRO. MOD. assembly	AXQ1021	AXQ3121	AXQ3121	AXQ3121	
	Round knob	AAB2226	AAB1341	AAB1341	AAB1341	
	Front panel	AMB7094	AMB7091	AMB7094	AMB7094	

FM/AM TUNER MODULE

AXQ3112 and AXQ1012 have the same construction except for the following:

Mark	Symbol & Description	Part No.		Remarks
		AXQ1012	AXQ3112	
	AM RF TUNING BLOCK	AXX1041	AXX1025	

DOL. PRO. MOD. ASSEMBLY

AXQ3121 and AXQ1021 have the same construction except for the following:

Mark	Symbol & Description	Part No.		Remarks
		AXQ1021	AXQ3121	
	C1852, C1853 C1864, C1865 R1849	ACH1270 (10 μ F/50V) ACH1262 (100 μ F/25V) RS1/10S000J	CEAS100M50 CEAS101M16 RS1/10S331J	

This diagram is viewed from the foil side.

PCB-1

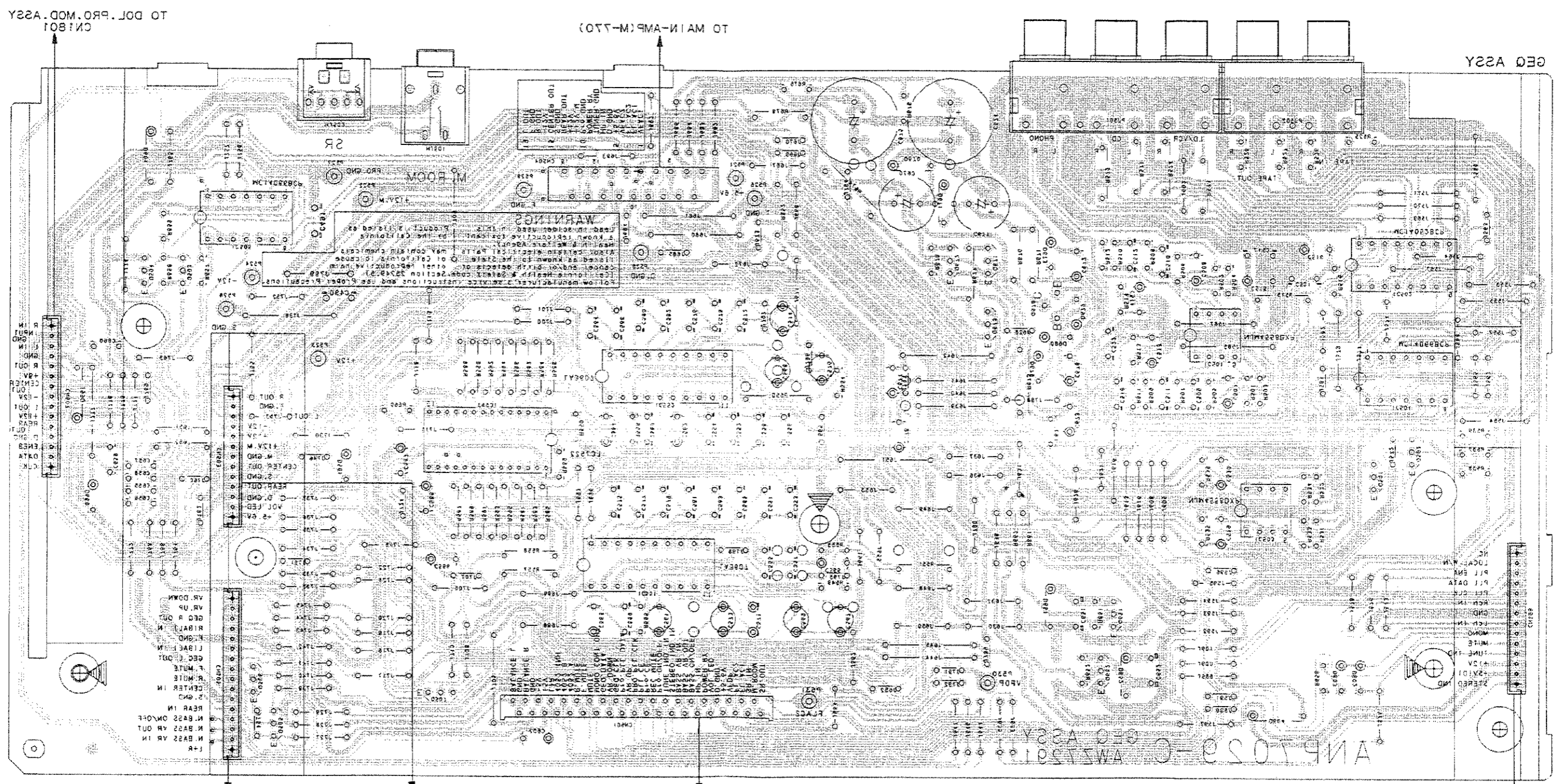

TO FM/AM TUNER MODULE CNE501
 TO DISPLAY ASSY CNE301
 TO VR ASSY CNE403
 TO VR ASSY CNE405

0208
 0205 0201
 1C93 1C901
 0255 0253
 0271 0275
 1C51 1C55
 1C53 0207
 0208
 0205 0201
 1C93 1C901
 0255 0253
 0271 0275
 1C51 1C55
 1C53 0207
 0208

A

B

C

D

A

B

C

D

2.2.2 GEQ ASSY

This diagram is viewed from the mounted parts side.

PCB-1

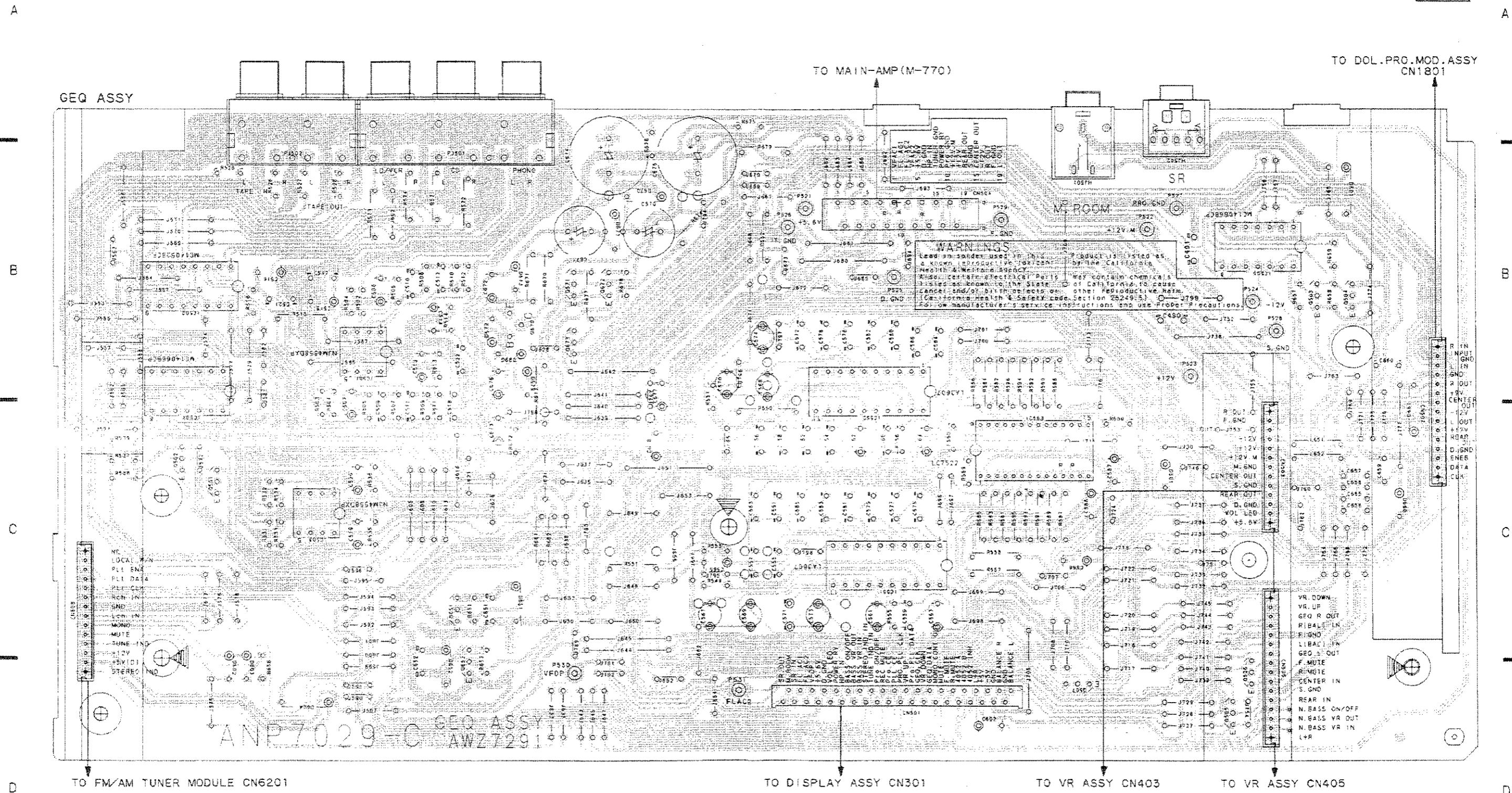

ANP7029-C GEQ ASSY
AWZ7291

- IC502 IC504
- IC503 IC501
- Q651 Q670
- Q671 Q672
- IC551 IC552
- IC553 Q507
- Q505 IC505 Q503 Q504
- Q502 Q501
- Q652
- Q673
- Q506

TO FM/AM TUNER MODULE CN6201 (-SCH-5)

TO DOL. PRO. MOD. ASSY CN...

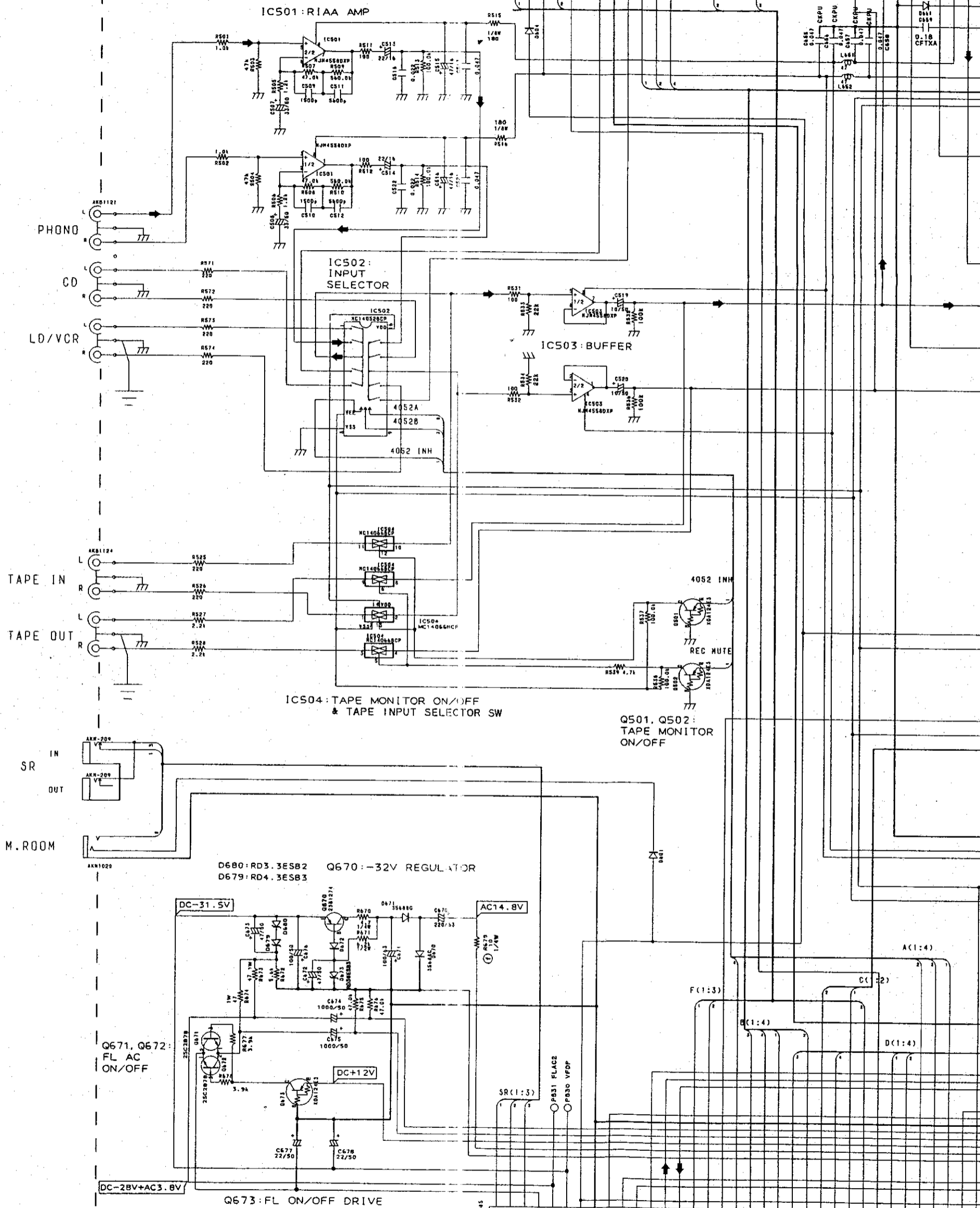

DIODES
Other diodes (not noted) are H55104-02

SP. OUT
M. ROOM
SR. IN
FL AC1
FL AC2
VFDP
+5.0V
D. GND
VOL LED
POWER RY
HP IN
N. BASS ON/OFF
N. BASS VR IN
STEREO IND IN
TUNE IND IN
PRO ON/OFF
REC MUTE
PRO. CE
PLL CE
PRO. PLL CLK
VR UP
PRO. PLL DATA
REQ. CLK
VR DOWN
REQ. DATA
MHO CONT OUT
MUTE
F. MUTE
R. MUTE
4052 A
4052 B
4052 INH
L+R
+5V

TO DISPLAY ASSY CN301 (-SCH-3)

SCH-2

GEQ ASSY

DOL. PRO. MOD. ASSY CN1801 (-SCH-5)

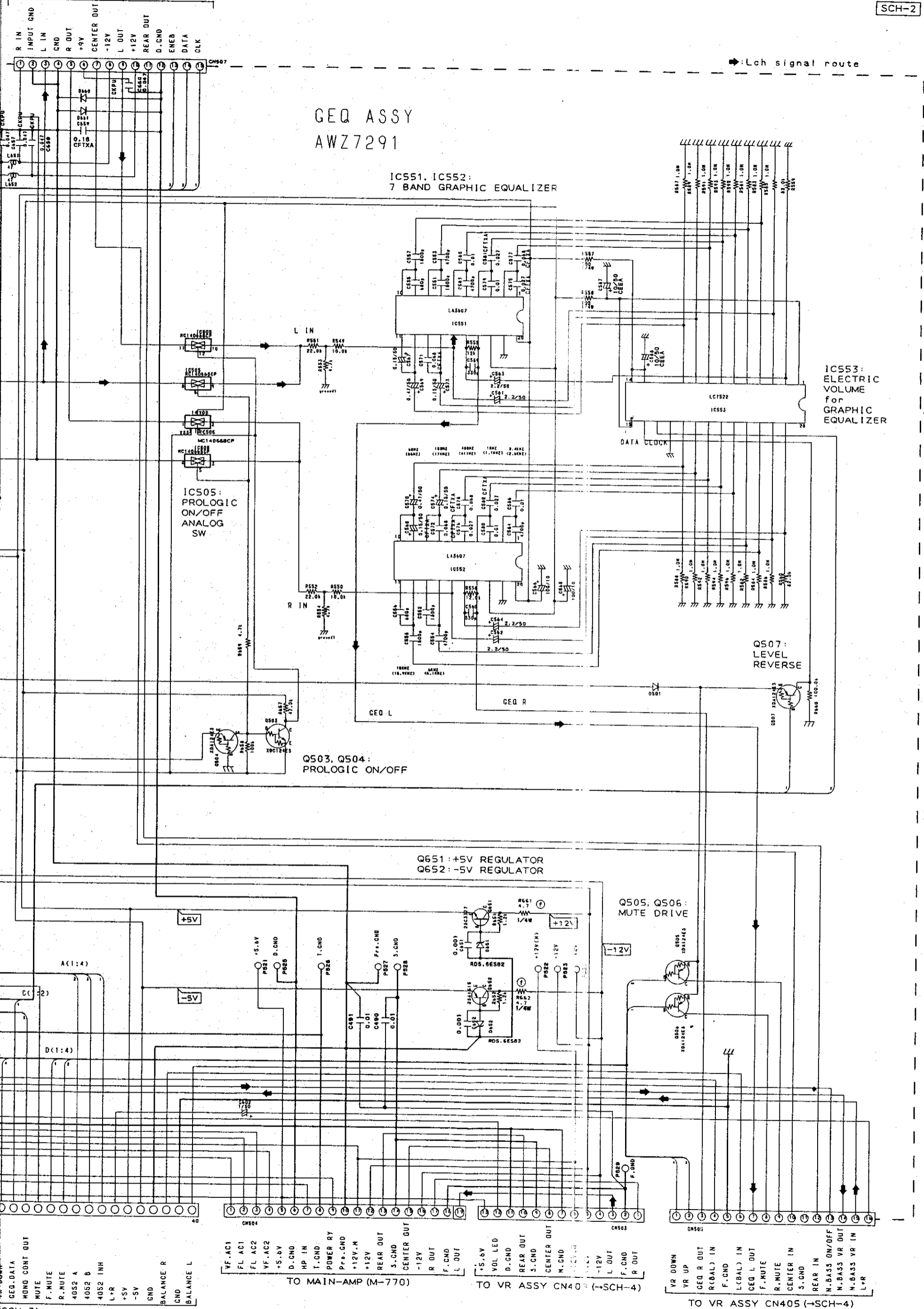

SCH-3)

GEQ ASSY

2.2.3 DISPLAY ASSY

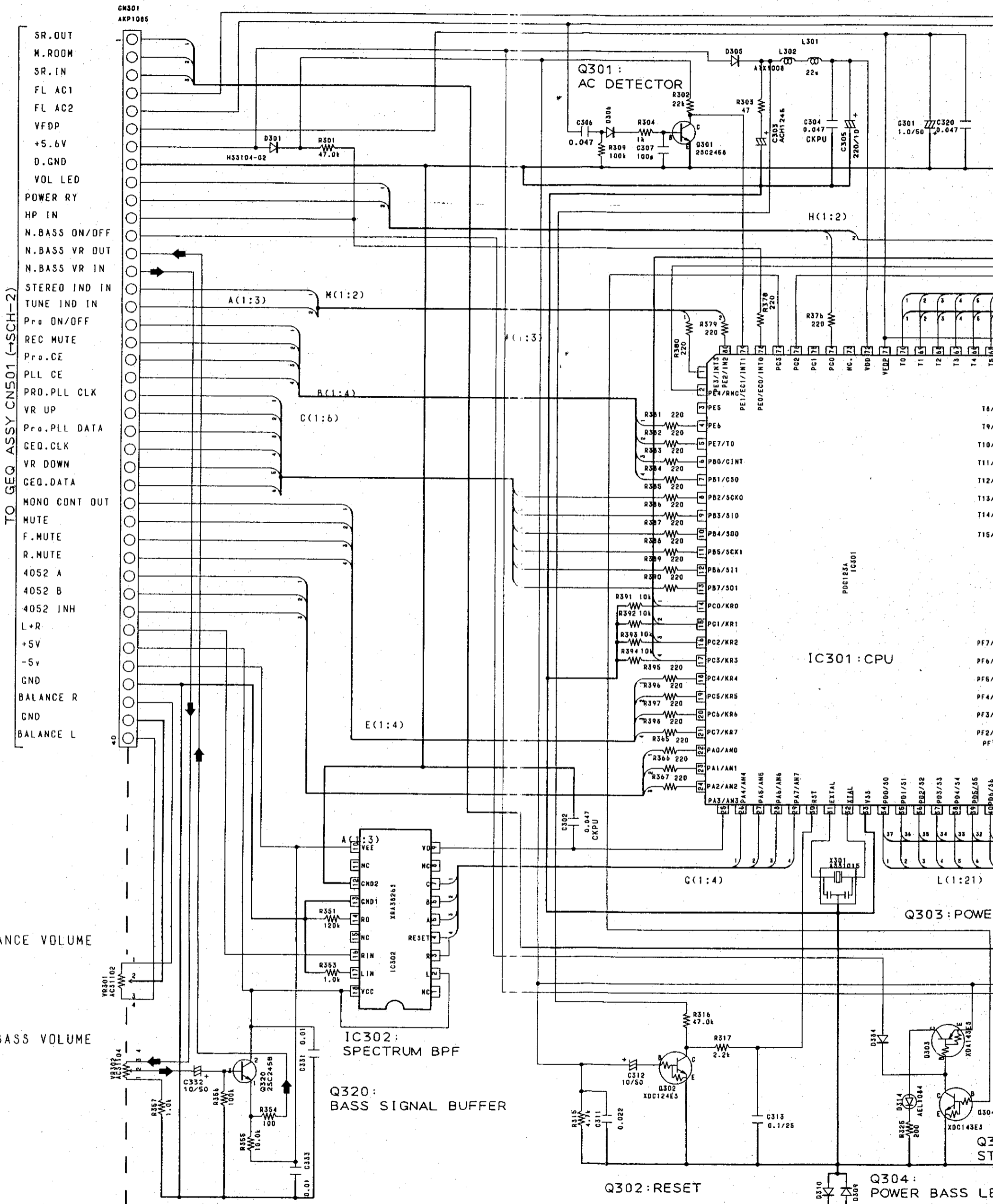

DIODES
Other diodes (not noted) are H5S104-02

SCH-3
DISPLAY ASSY

→ Lch signal route

SCH-3

DISPLAY ASSY
AWZ7290

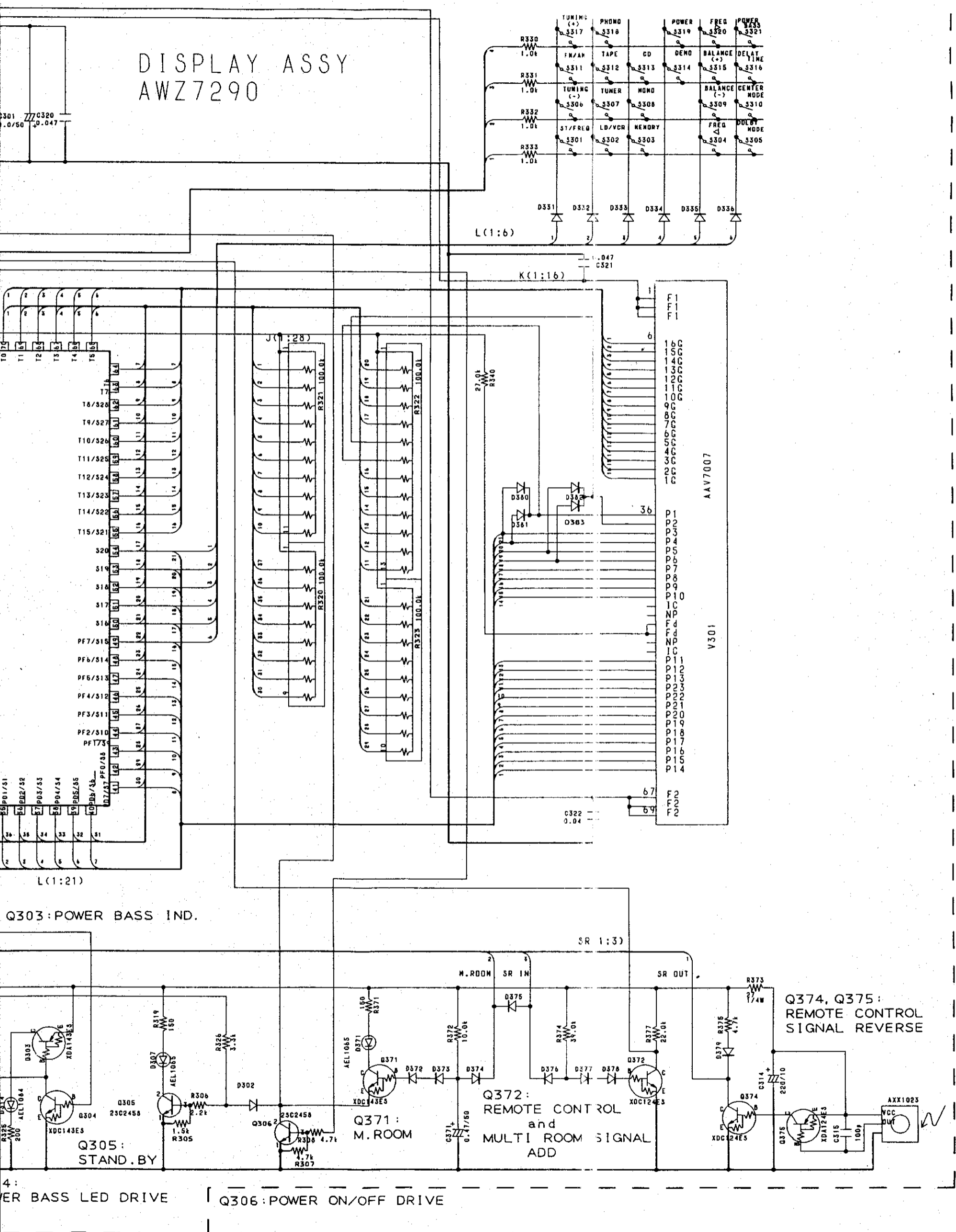

A
B
C
D
E
F

DISPLAY ASSY

SCH-3

● This diagram is viewed from the mounted parts side.

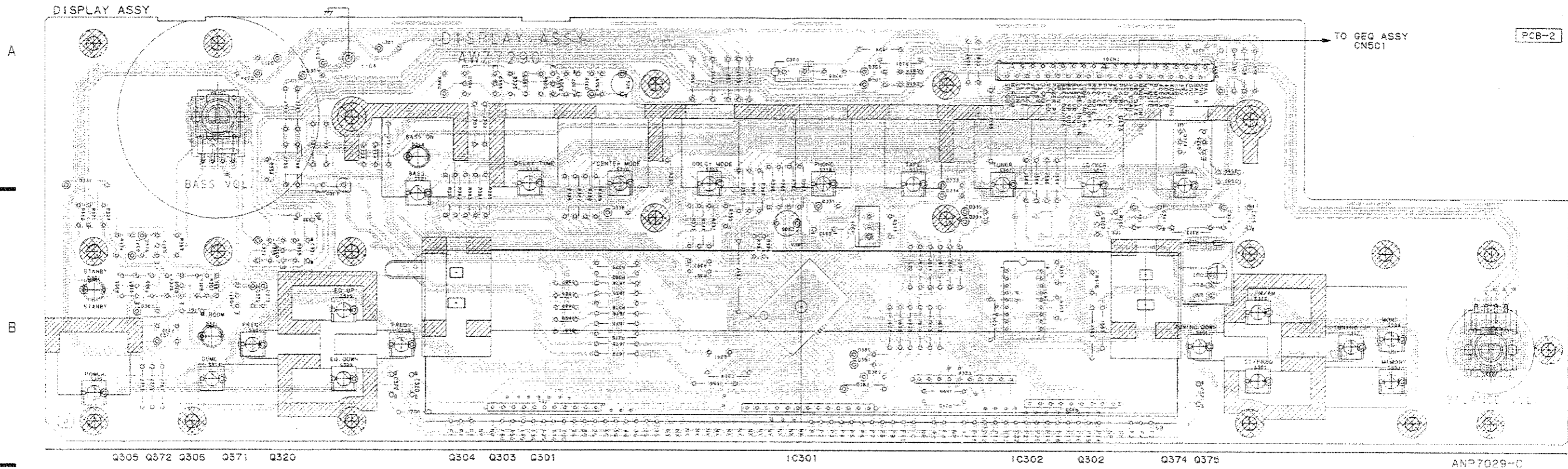

● This diagram is viewed from the foil side.

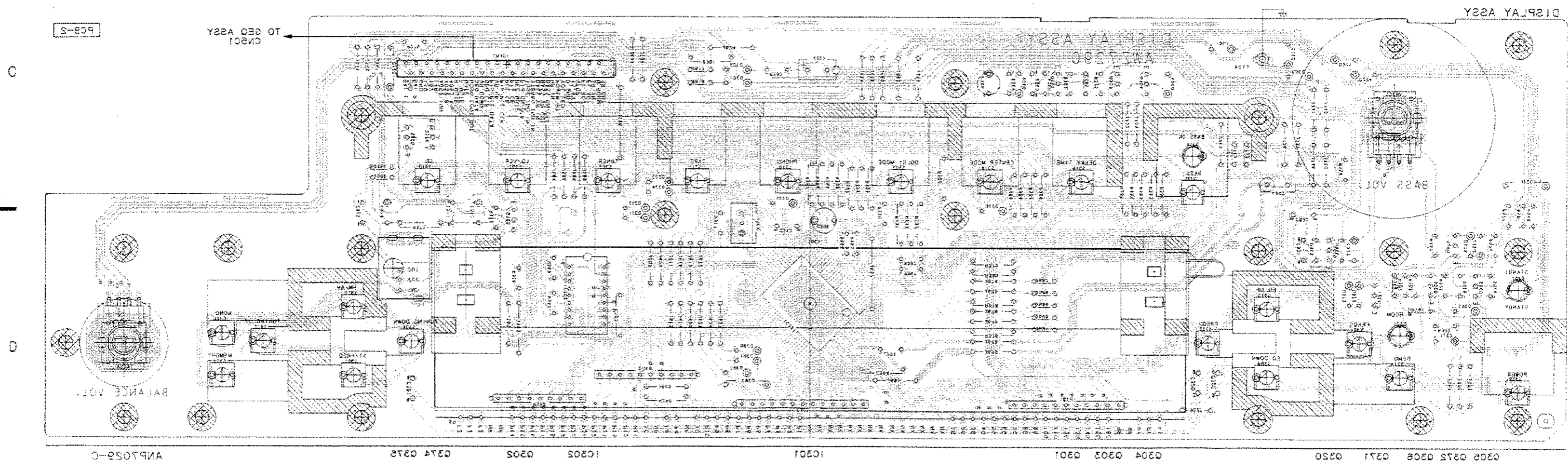

2.2.4 VR ASSY

A

B

C

D

A

B

C

D

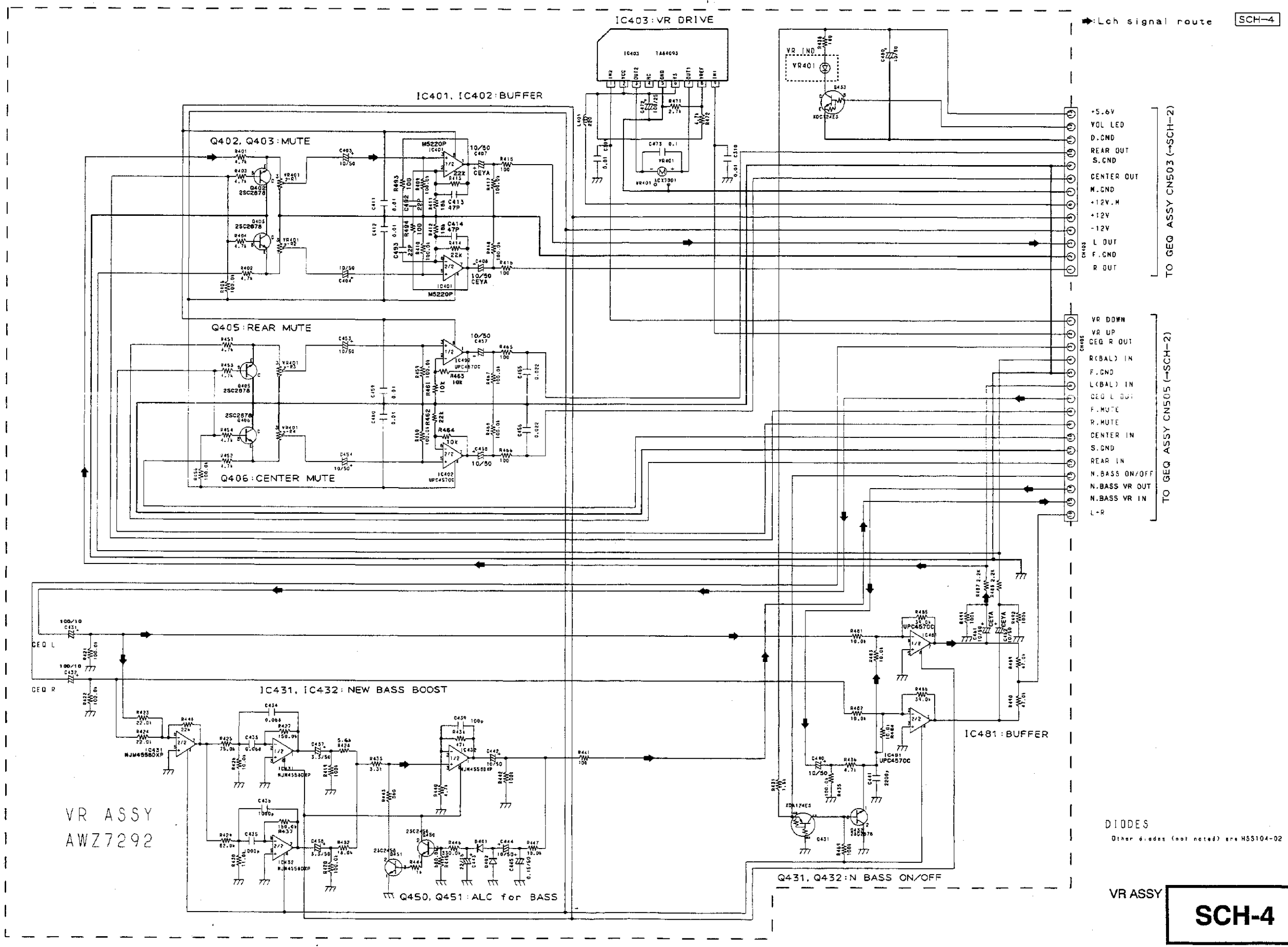

VR ASSY
SCH-4

VR ASSY
SCH-4

● This diagram is viewed from the mounted parts side.

● This diagram is viewed from the foil side.

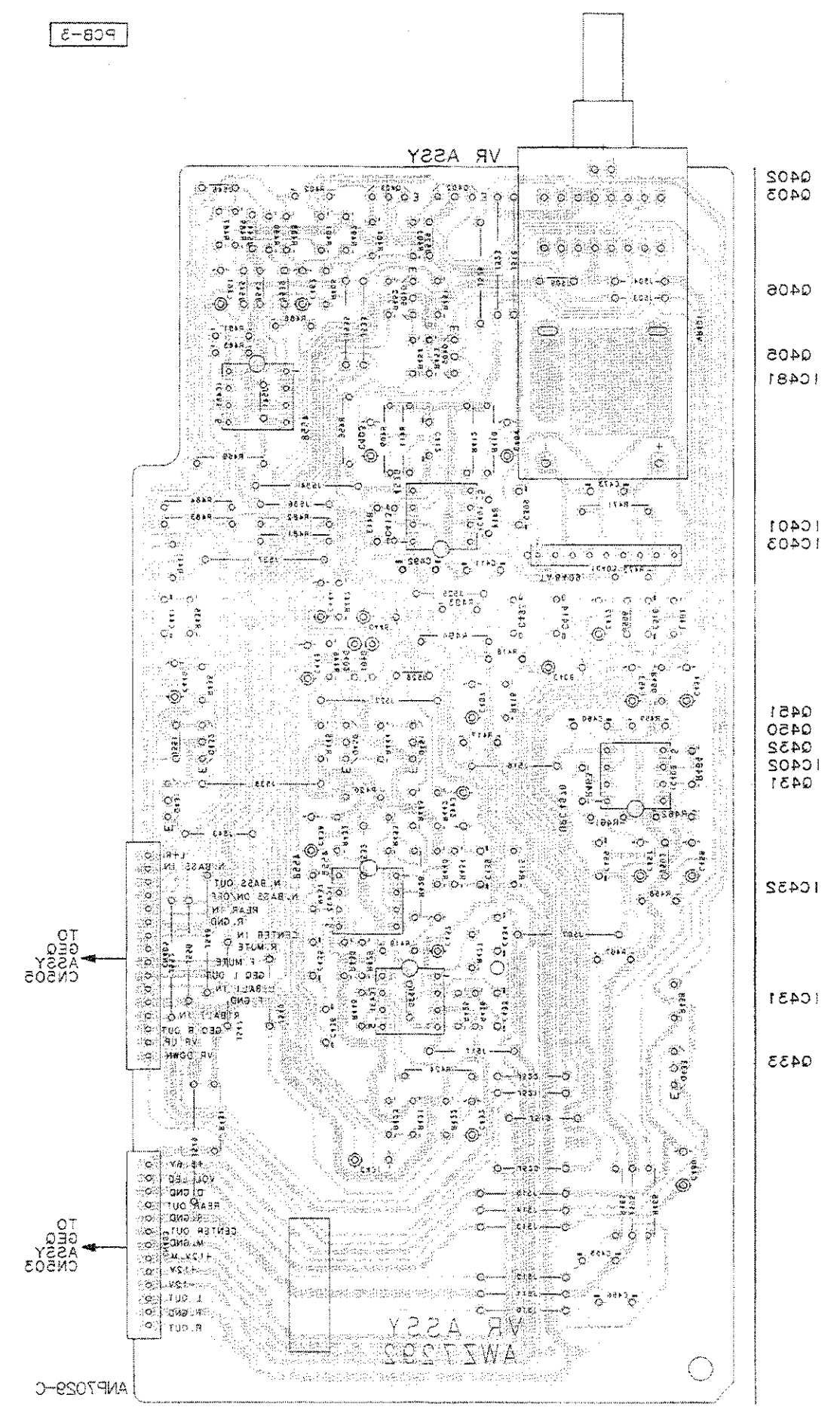
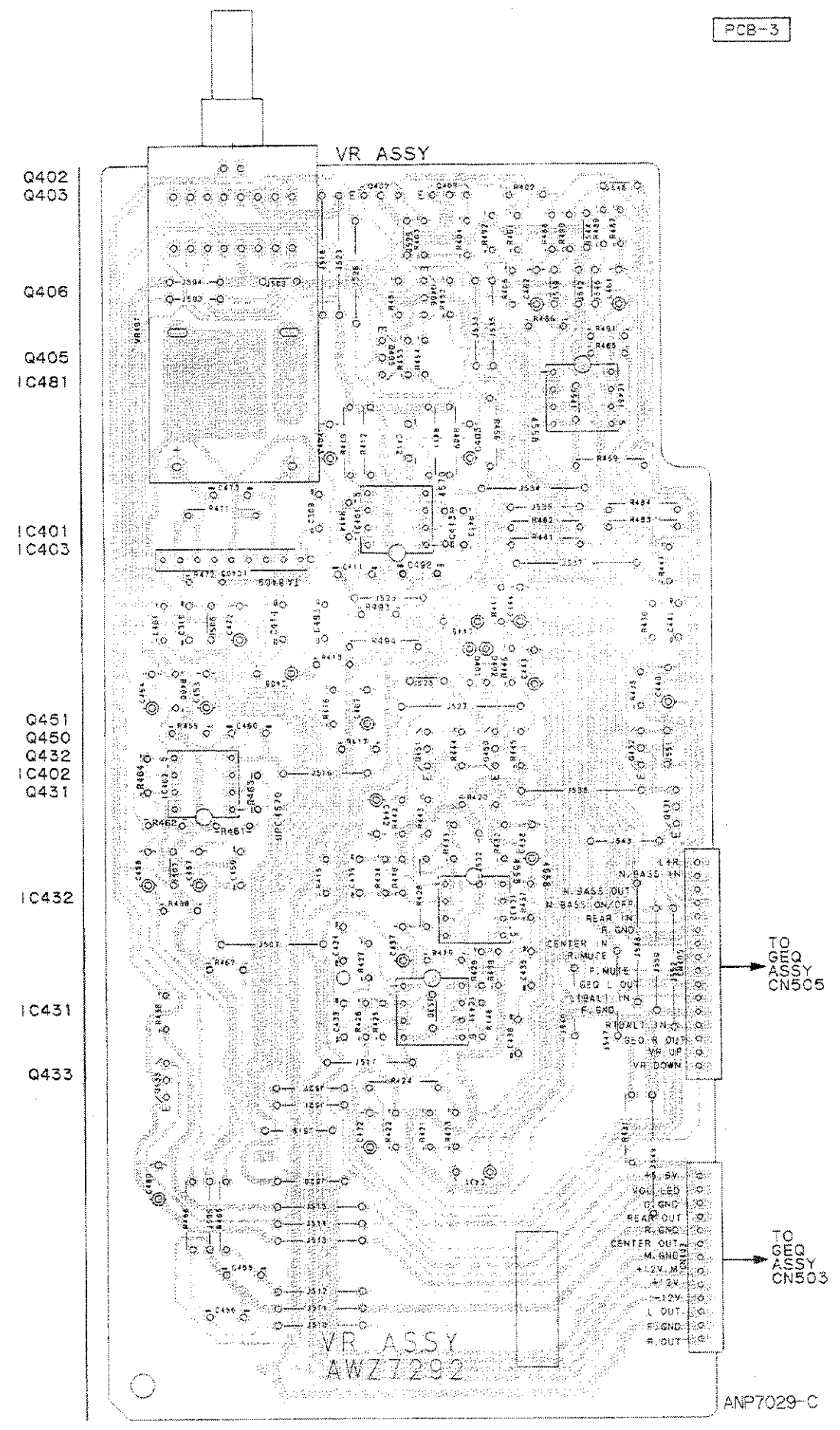

Q402
Q403
Q406
Q405
IC481
IC401
IC403
Q451
Q450
Q432
IC402
Q431
IC432
IC431
Q433

2.2.5 FM/AM TUNER MODULE

SCH-5

FM/AM TUNER MODULE (AXQ1012)

↗: FM signal route
↘: AM signal route

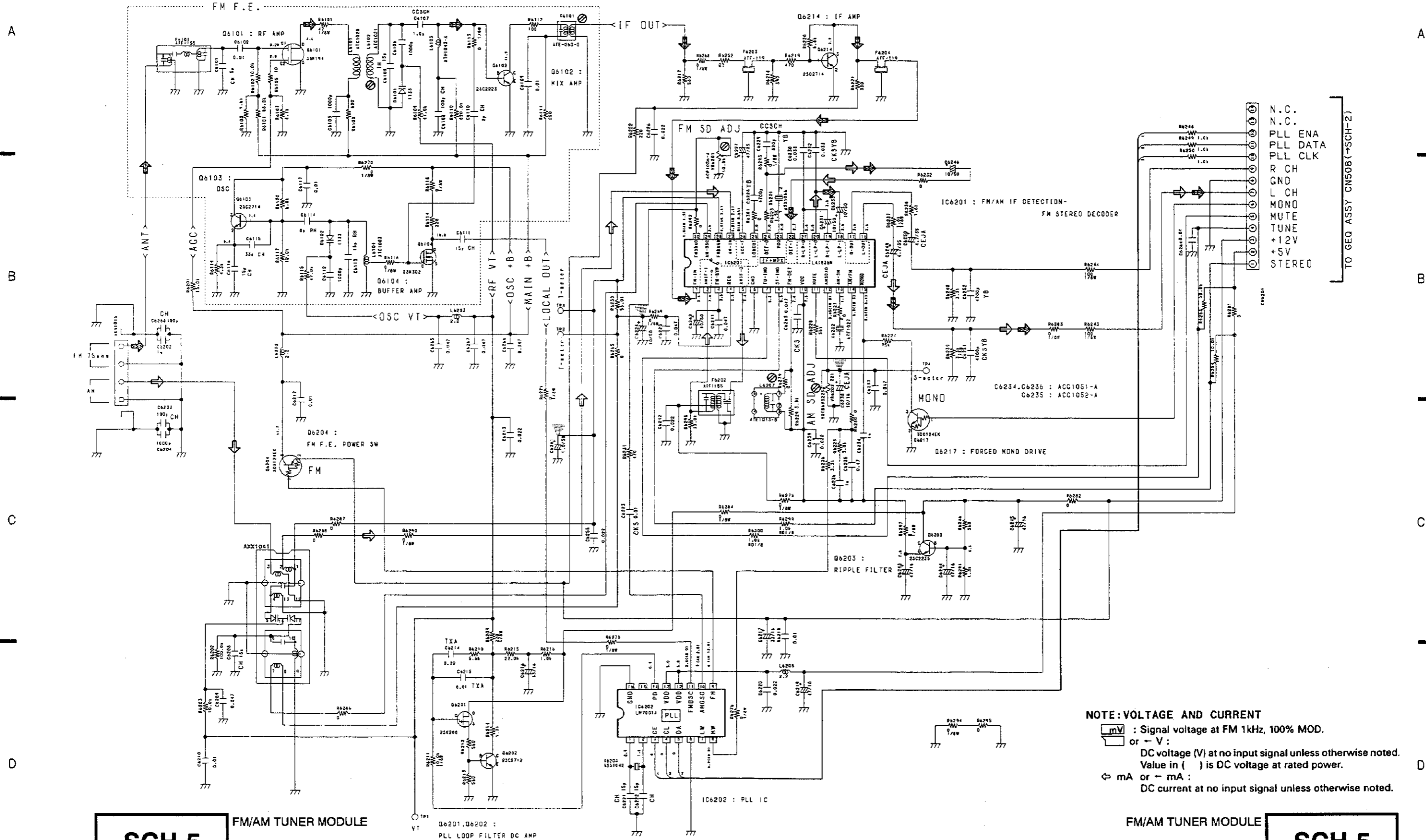

NOTE: VOLTAGE AND CURRENT
 mV : Signal voltage at FM 1kHz, 100% MOD.
 or - V : DC voltage (V) at no input signal unless otherwise noted.
 Value in () is DC voltage at rated power.
 mA or - mA : DC current at no input signal unless otherwise noted.

SCH-5

FM/AM TUNER MODULE

FM/AM TUNER MODULE

SCH-5

● This diagram is viewed from the mounted parts side.

● This diagram is viewed from the foil side.

PCB-4

PCB-4

A AM ANTENNA TERMINAL FM ANTENNA TERMINAL FM/AM TUNER MODULE

FM/AM TUNER MODULE FM ANTENNA TERMINAL AM ANTENNA TERMINAL

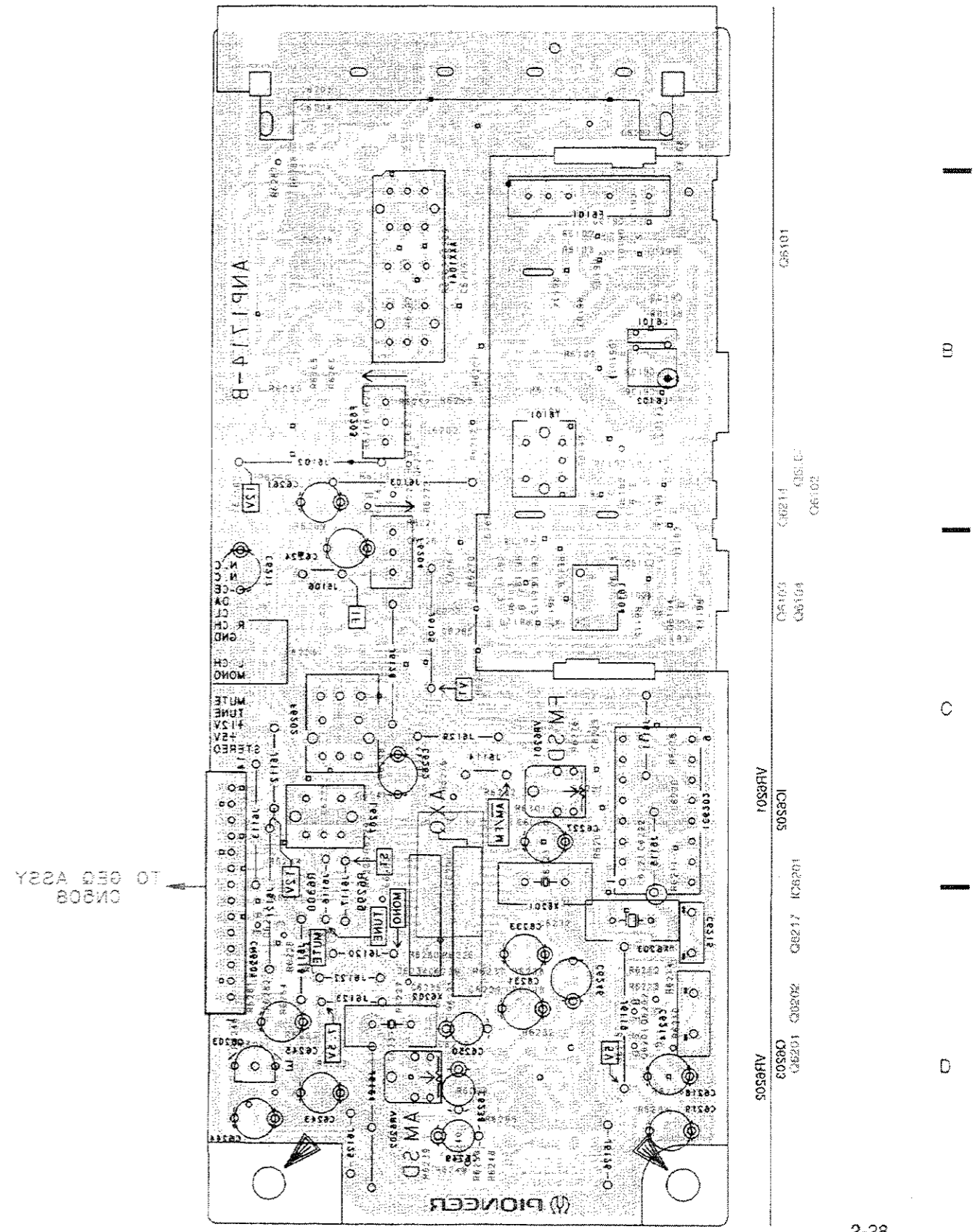
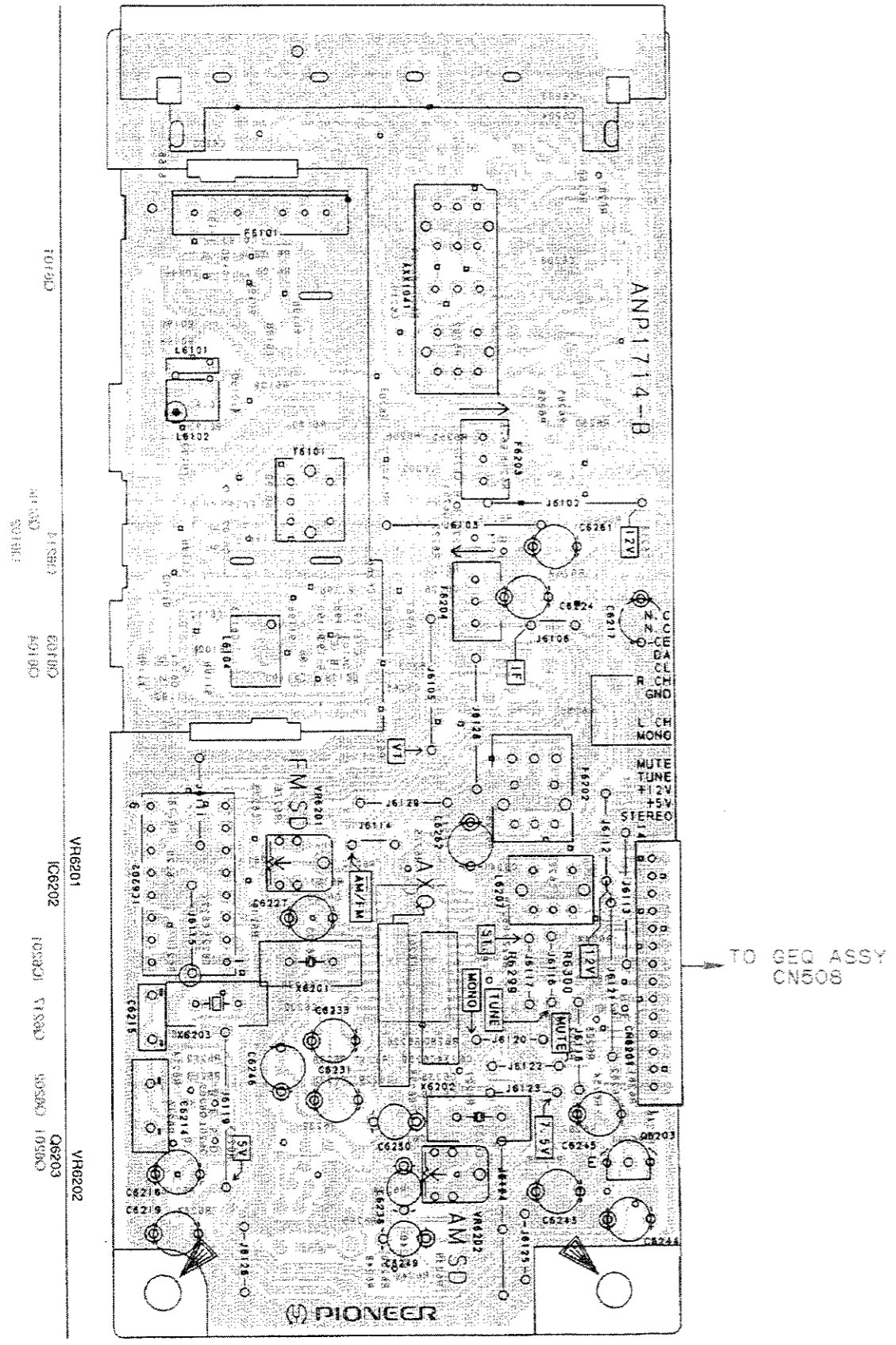

1 2 3 4 5 6

2.2.6 DOL. PRO. MOD. ASSY

A

B

C

D

A

B

C

D

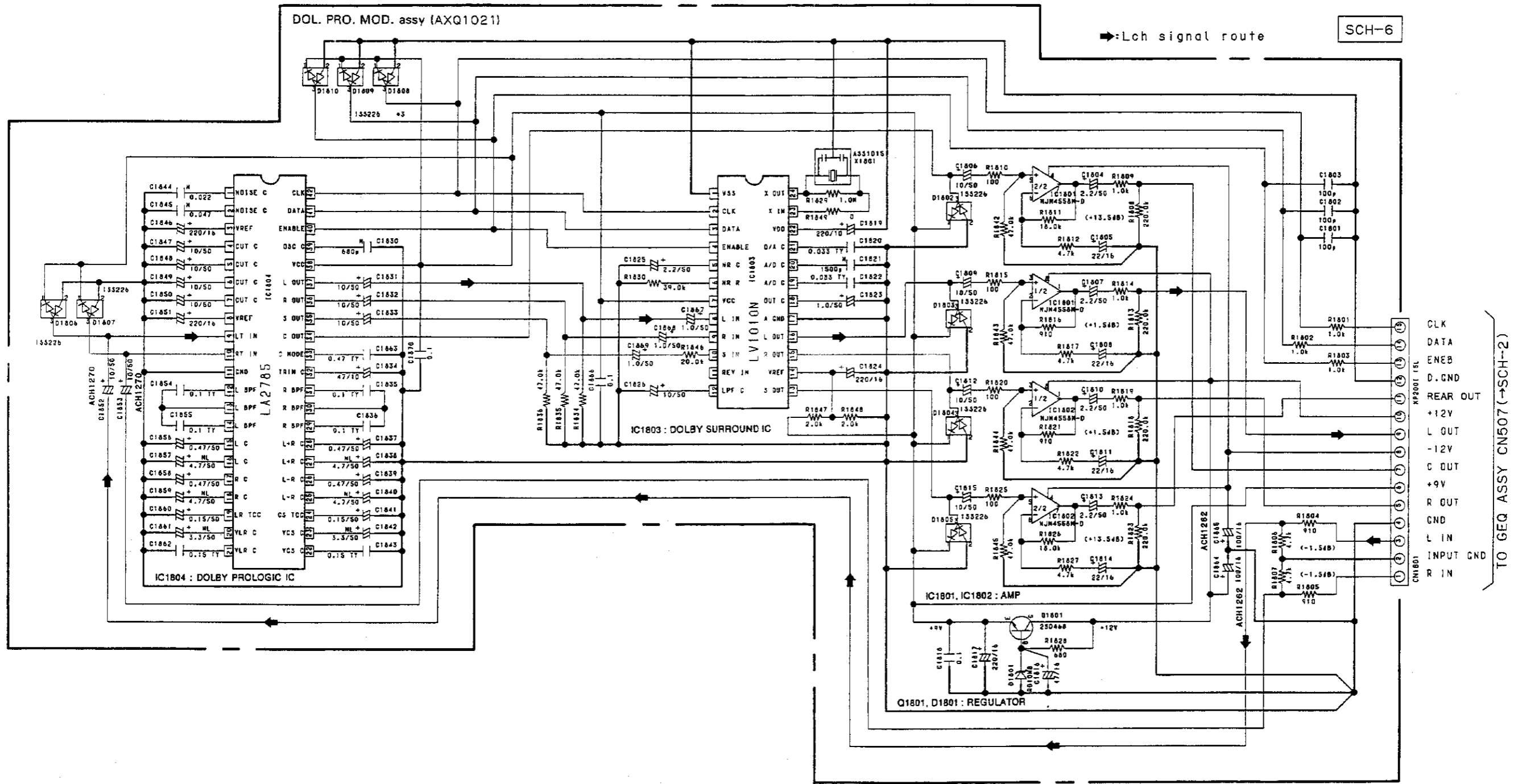

SCH-6

DOL. PRO. MOD. ASSY

DOL. PRO. MOD. ASSY

SCH-6

- This diagram is viewed from the pink colored foil side.
- This PCB is double sided.

PCB-5

IC1802 IC1803 IC1801 Q1801 IC1804
 DOL. PRO. MOD. assy

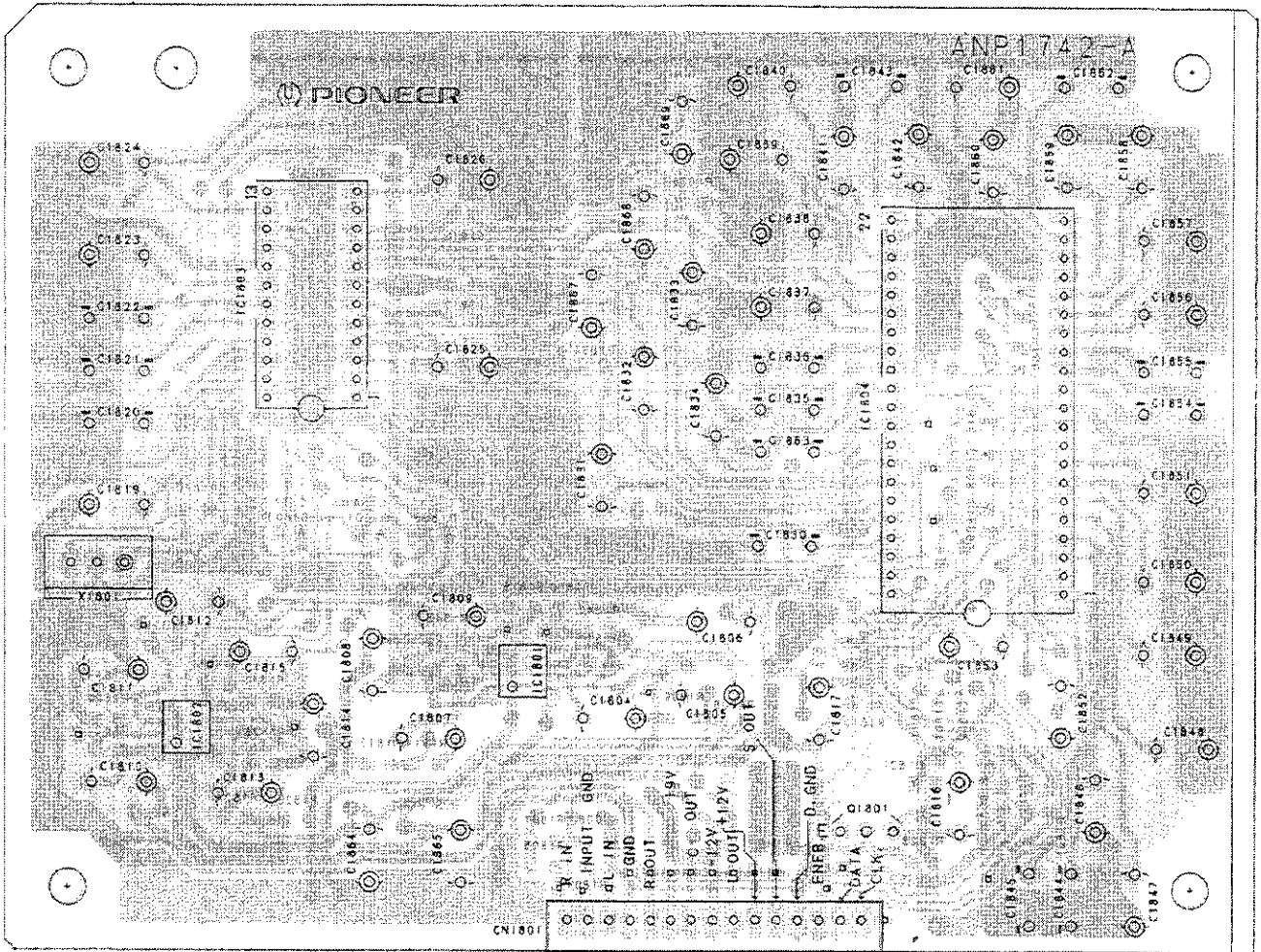

TO GEQ ASSY CN507

- This diagram is viewed from the gray colored foil side.
- This PCB is double sided.

A

A

PCB-2

IC1804

IC1801

IC1801

IC1803

IC1805

DOJ. PRO. MOD. assy

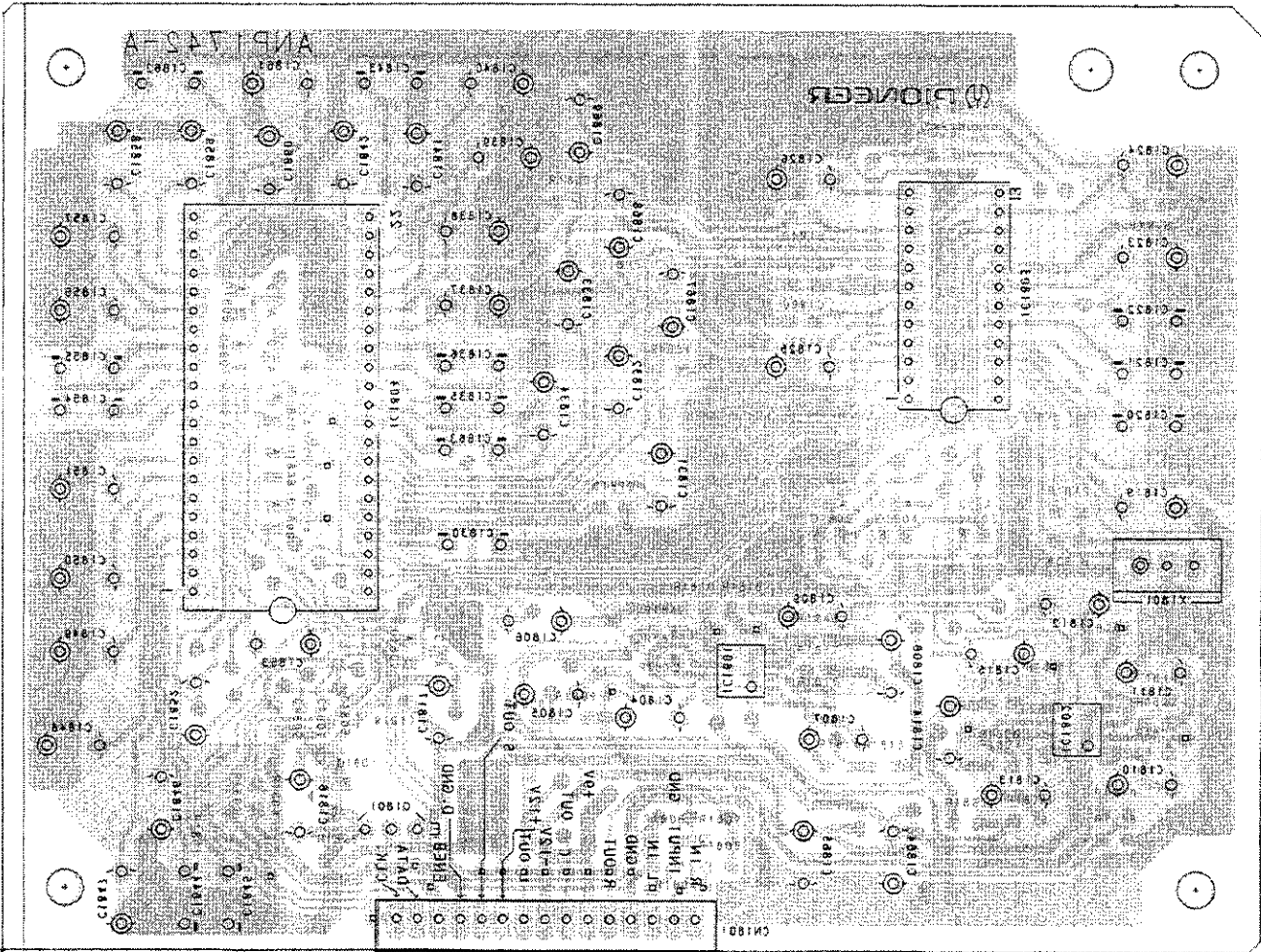

TO GEO ASSY CAB07

2.3 BLOCK DIAGRAM

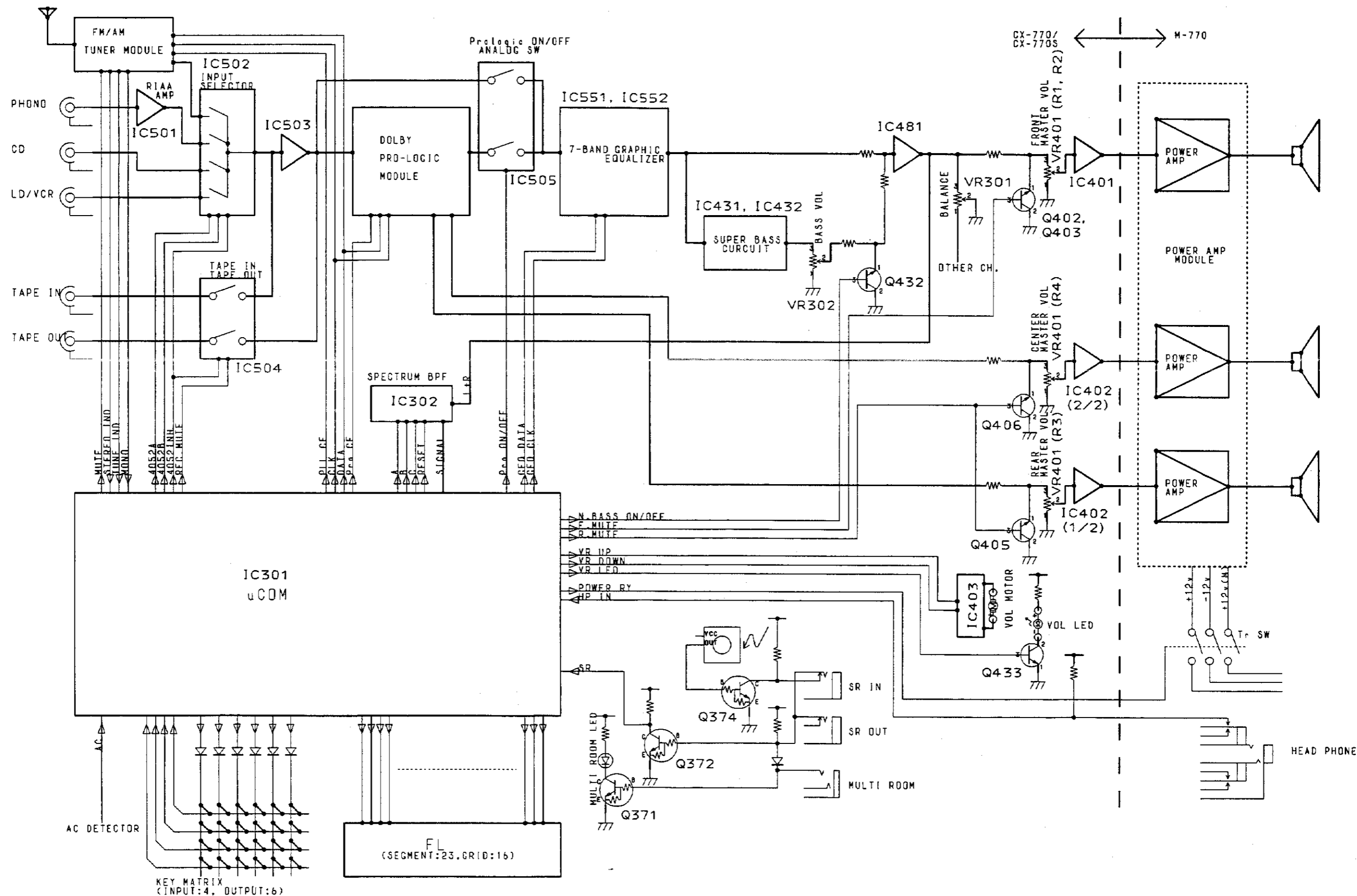

2.4 REMOTE CONTROL UNIT (CU-CX007)

● EXPLODED VIEW

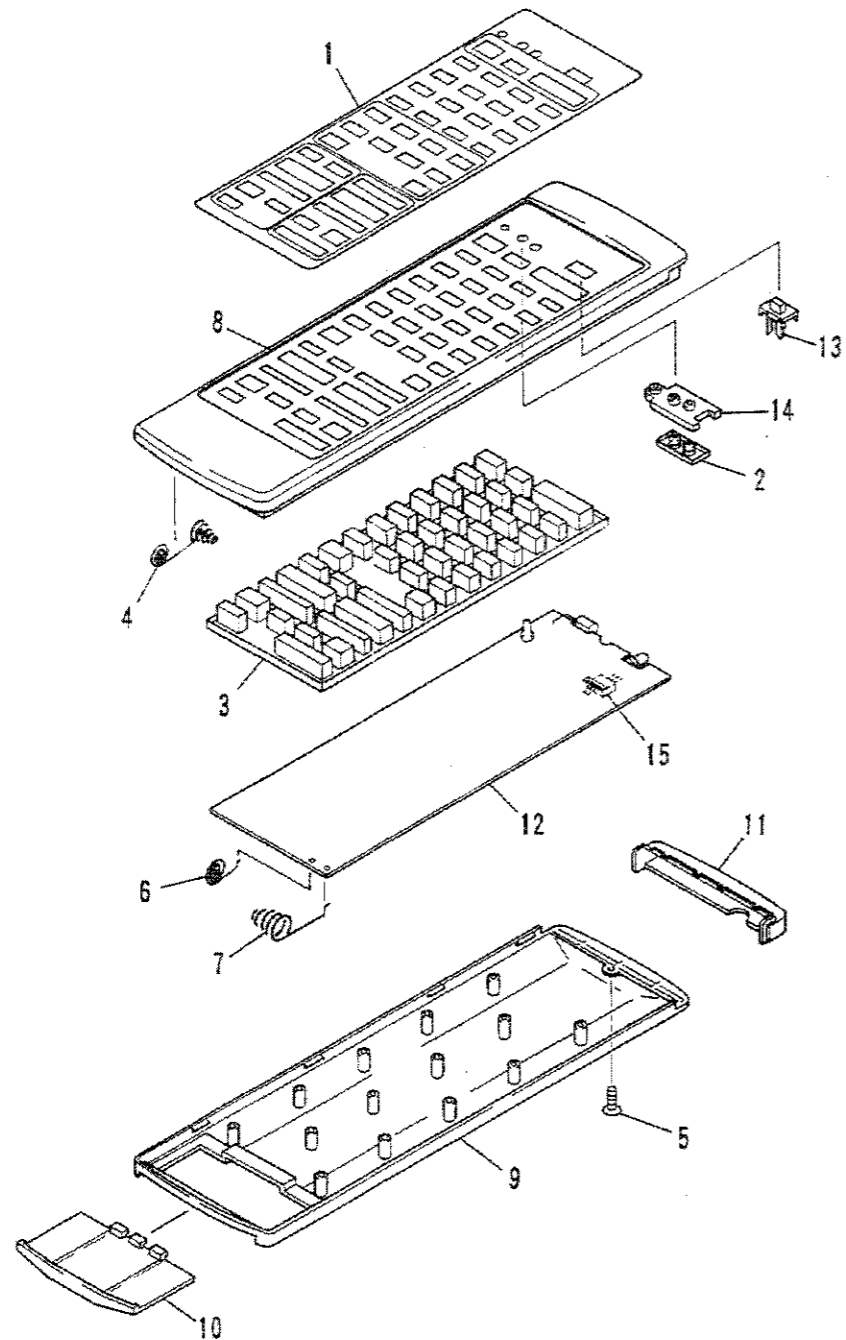

● PCB PATTERN

- ⎓ : Indicates a chip resistor.
- ⎓ : Indicates a chip capacitor.
- : Indicates a chip transistor.
- ⊕ : Indicates a chip diode.

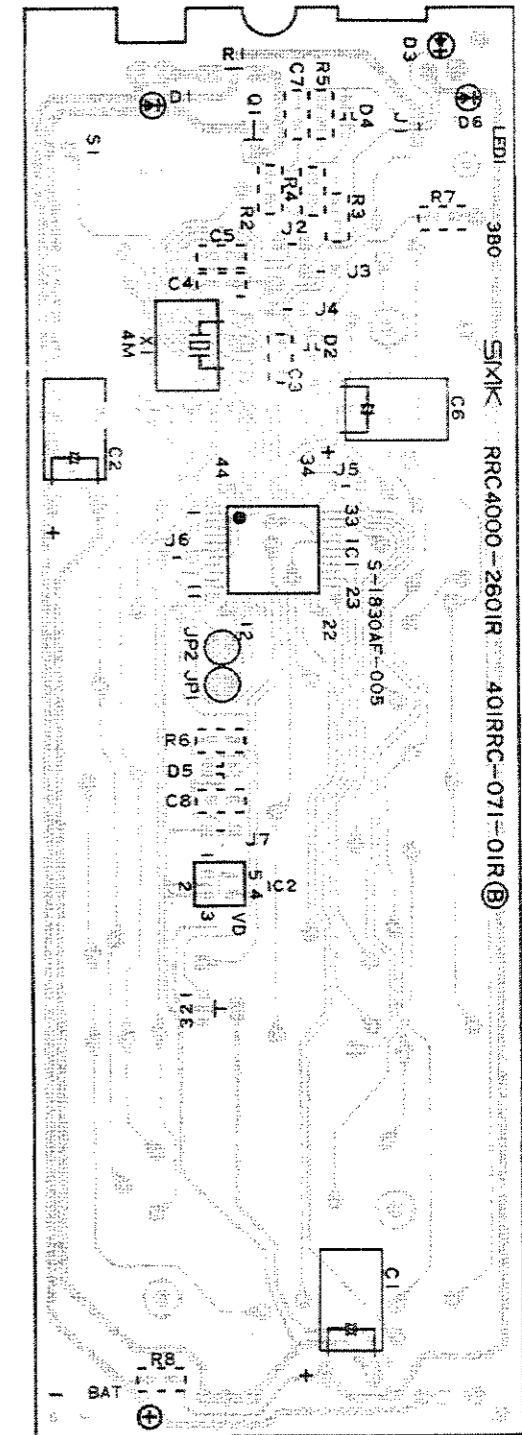
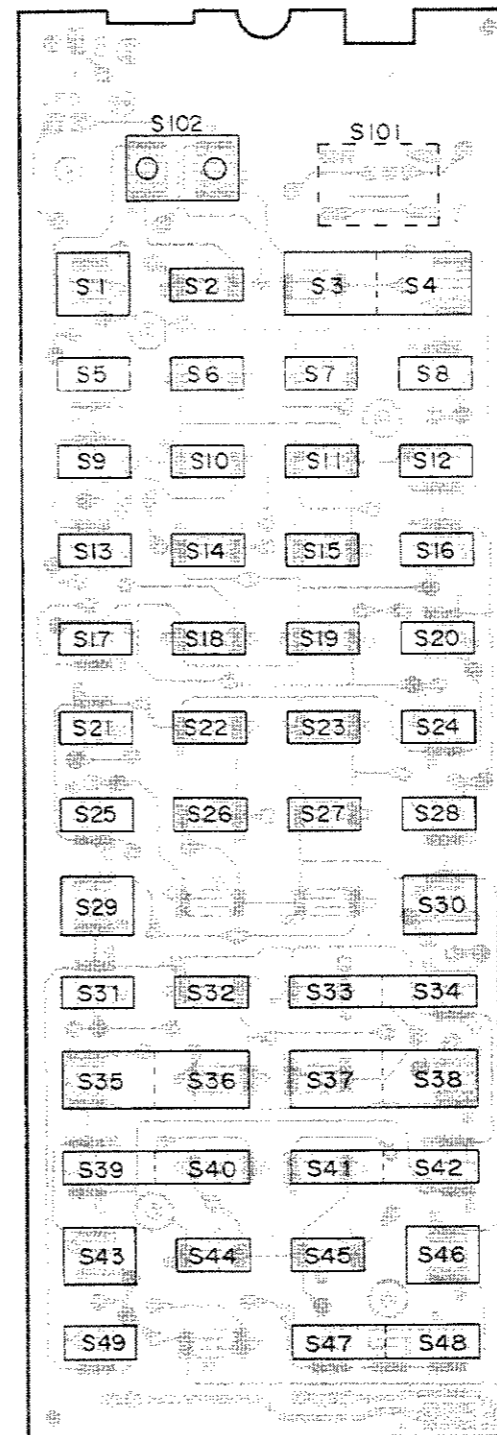

● SCHEMATIC DIAGRAM

NOTE FOR SCHEMATIC DIAGRAMS (Type 2A)

- When ordering service parts, be sure to refer to "PARTS LIST OF EXPLODED VIEWS" or "PCB PARTS LIST".
- Since these are basic circuits, some parts of them or the values of some components may be changed for improvement.
- RESISTORS:
Unit: k: kΩ, M: MΩ, or Ω unless otherwise noted.
Rated power: 1/4W, 1/6W, 1/8W, 1/10W unless otherwise noted.
Tolerance: (F): ±1%, (G): ±2%, (K): ±10%, (M): ±20% or ±5% unless otherwise noted.
- CAPACITORS:
Unit: p: pF or μF unless otherwise noted.
Ratings: capacitor (μF)/ voltage (V) unless otherwise noted.
Rated voltage: 50V except for electrolytic capacitors.

- COILS:
Unit: m: mH or μH unless otherwise noted.
- VOLTAGE AND CURRENT:
□ or - V :
DC voltage (V) at no input signal unless otherwise noted.
mA or - mA :
DC current at no input signal unless otherwise noted.
- OTHERS:
• ∅ or ∅ : Adjusting point.
• ◀ : Measurement point.
• The Δ mark found on some component parts indicates the importance of the safety factor of the parts. Therefore, when replacing, be sure to use parts of identical designation.
- SCH-□ ON THE SCHEMATIC DIAGRAM:
• SCH-□ indicates the drawing number of the schematic diagram. (SCH stands for schematic diagram.)

- SWITCHES (Underline indicates switch position):
S101: AUDIO/VIDEO
S102: LEARN · RESET
S1: AMP POWER
S2: FUNCTION
S3: MASTER VOLUME -
S4: MASTER VOLUME +
S5: TV POWER
S6: 1
S7: 2
S8: 3
S9: BAND TV FUNC
S10: 4
S11: 5
S12: 6
S13: 0/10
S14: 7
S15: 8
S16: 9
S17: FREQUENCY TV VOLUME -
S18: FREQUENCY TV VOLUME +
S19: DISC
S20: TRACK
S21: DOLBY PRO LOGIC
S22: 3CH LOGIC
S23: TEST TONE
S24: CENTER MODE
S25: REAR LEVEL -
S26: REAR LEVEL +
S27: CENTER LEVEL -
S28: CENTER LEVEL +
S29: DELAY TIME
S30: POWER BASS
S31: DISC SELECT - (DISC SIDE A) CD/LD
S32: DISC SELECT + (DISC SIDE B) CD/LD
S33: DECK I (VCR CH -) TAPE/VCR
S34: DECK II (VCR CH +) TAPE/VCR
S35: II CD/LD
S36: TAPE/VCR
S37: TAPE/VCR
S38: TAPE/VCR
S39: CD/LD
S40: TAPE/VCR
S41: TAPE/VCR
S42: TAPE/VCR
S43: POWER CD/LD
S44: TAPE/VCR
S45: TAPE/VCR
S46: POWER TAPE/VCR
S47: TAPE SELECT TV/VCR
S48: TAPE/VCR
S49: SHIFT

NOTE

- indicates a chip resistor.
- ⊕ indicates a chip capacitor.
- indicates a chip transistor.
- indicates a chip diode.

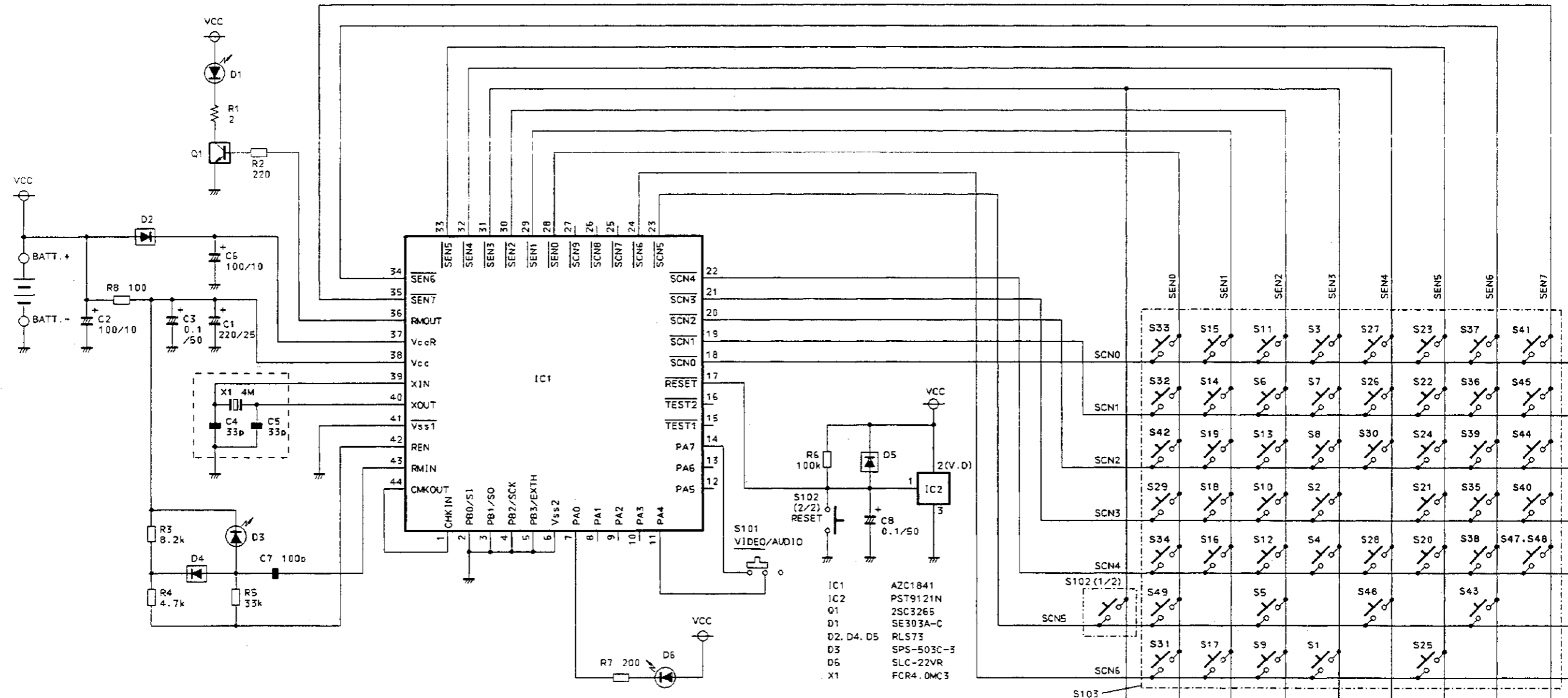

SCH-7

SCH-7 SCHEMATIC DIAGRAM (For CU-CX007 (AXD7023))

SCH-7 SCHEMATIC DIAGRAM (For CU-CX007 (AXD7023))