

Service Manual

**ORDER NO.
CRT-468-0**

CASSETTE MECHANISM ASSEMBLY

CX-156/A, CX-156/B

- This service manual is for cassette mechanism assembly used in car stereo components.
- Refer to the service manual for individual models for details on sections other than the cassette mechanism assembly.

Model	Service Manual	Cassette Mechanism Assembly
FX-K5/EW	CRT-469	CX-156/A
FX-K5B/EW		CX-156/A
FX-K5SDK/WG		CX-156/A
FEX-55/US, CA, CS	CRT-471	CX-156/A
FEX-50/ES	CRT-470	CX-156/A
KX-E60/EW	CRT-476	CX-156/B

Model	Service Manual	Cassette Mechanism Assembly

CONTENTS

1. REPLACEMENT OF PARTS IN CASSETTE MECHANISM.....	1	4. EXPLODED VIEW	10
2. MECHANISM DESCRIPTION.....	4	5. CONNECTION DIAGRAM.....	13
3. ADJUSTMENT	8	6. SCHEMATIC CIRCUIT DIAGRAM	14
		7. ELECTRICAL PARTS LIST	14

MC-Service

PIONEER ELECTRONIC CORPORATION 4-1, Meguro 1-Chome, Meguro-ku, Tokyo 153, Japan
PIONEER ELECTRONICS (USA) INC. P.O. Box 1760, Long Beach, California 90801 U.S.A.
 TEL: (800) 421-1404, (800) 237-0424
PIONEER ELECTRONIC (EUROPE) N.V. Keetbergplein 1, 2740 Beveren, Belgium TEL: 03/775-28-08
PIONEER ELECTRONICS AUSTRALIA PTY. LTD. 178-184 Boundary Road, Breaaside, Victoria 3195, Australia
 TEL: (03) 580-9911

1. REPLACEMENT OF PARTS IN CASSETTE MECHANISM

• Belt and capstan motor (M3) replacement

1. Remove the four screws and the cover. (Fig. 1)
2. The belt in Fig. 2 can be replaced. (Be sure that the belt is not greased and not twisted.)
3. To replace the capstan motor, remove the two screws shown in Fig. 2.

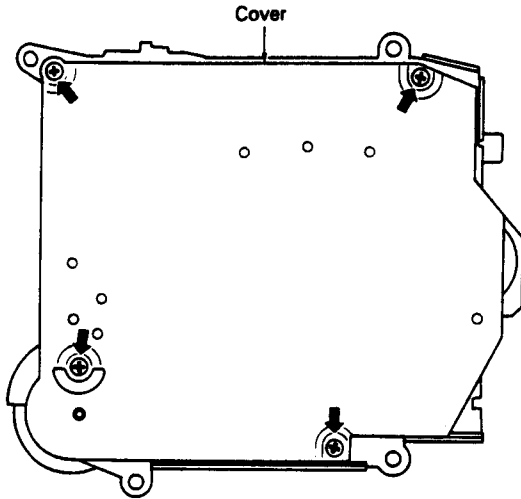

Fig. 1

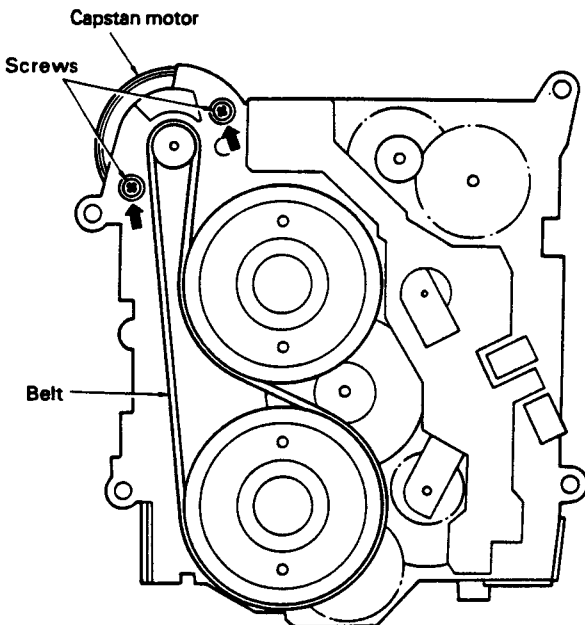

Fig. 2

• Cassette holder removal

1. Turn the capstan motor until the cassette holder drops down. (Do not turn the flywheel directly by hand.)
2. Remove the screw labeled "B", the collar and the spring.
3. Remove unit "A" and the cassette holder "D" and "E".

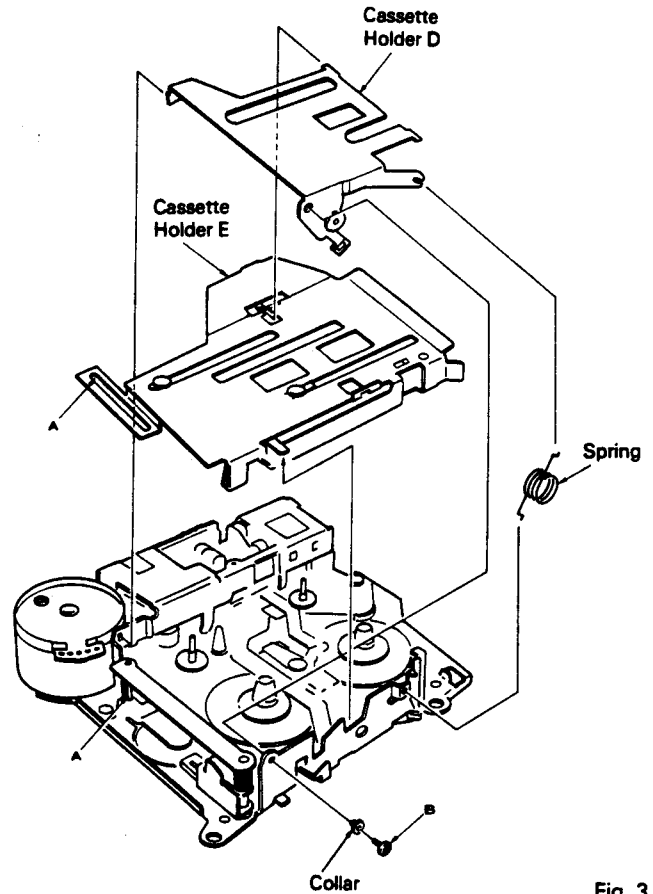

Fig. 3

• **Head unit replacement**

1. Remove the washer and spring.
2. Remove the screw labeled "F", and the head unit can be removed in the opposite direction.
3. Be careful of the following point during reassembly.
 - Put the head unit pins through the lever holes. (One in front and one in back.)

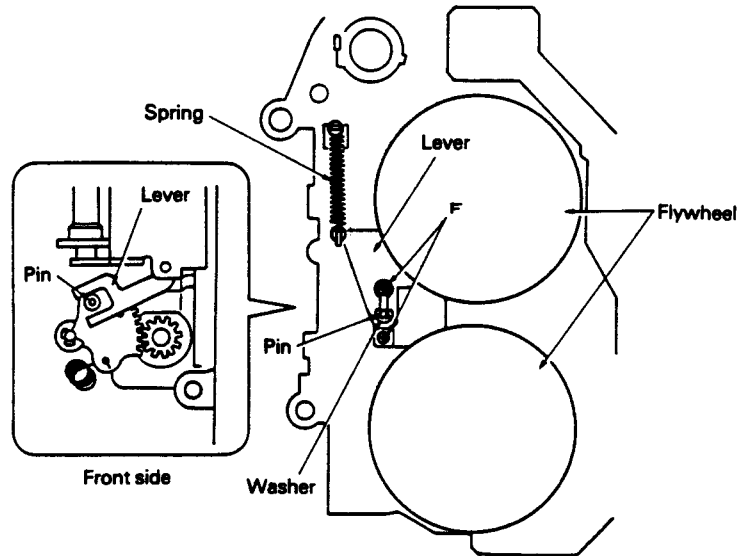

Fig. 4

• **Sub-motor replacement (M1 and M2)**

1. Remove the two screws labeled "G" and remove the P.C. board unit.
2. The sub-motor can be removed by removing the three screws indicated by the arrows.
3. Sub-motor 2 (for switching the FF/REW gear) can be replaced when the spacer has been removed. (The motor fits very snugly, so some force must be used to remove it.)
4. Sub-motor 1 (for turning and positioning the head) can be replaced by removing the belt, lock washer, pulley and two screws labeled "J".

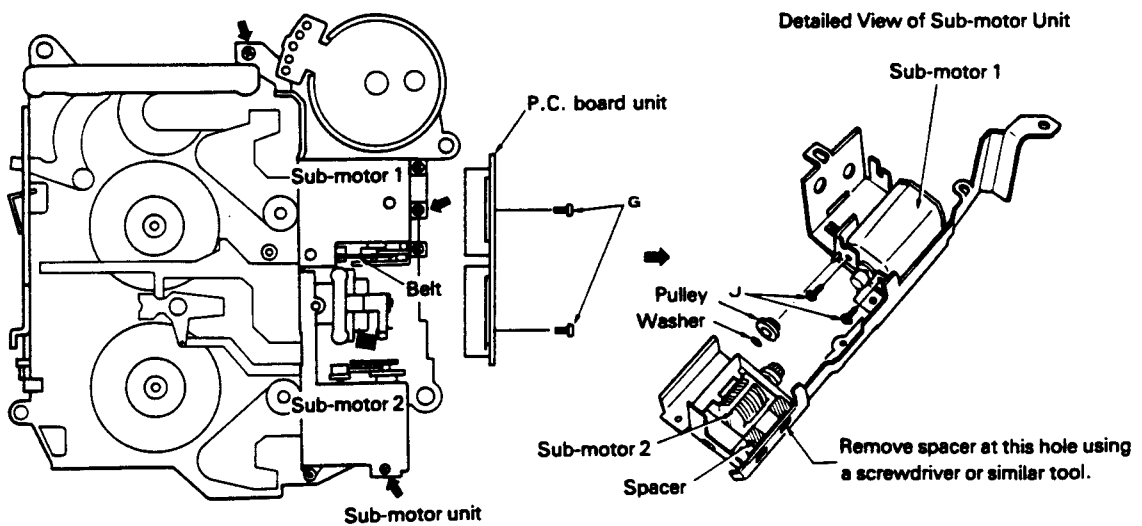

Fig. 5

• Reel unit replacement

1. Remove the six screws and the switch P.C. board.
2. Remove the screw labeled "K" and the collar and free the FF/REW idler gear.
3. The reel assy can be replaced by removing the two screws labeled "L" and removing the reel unit.

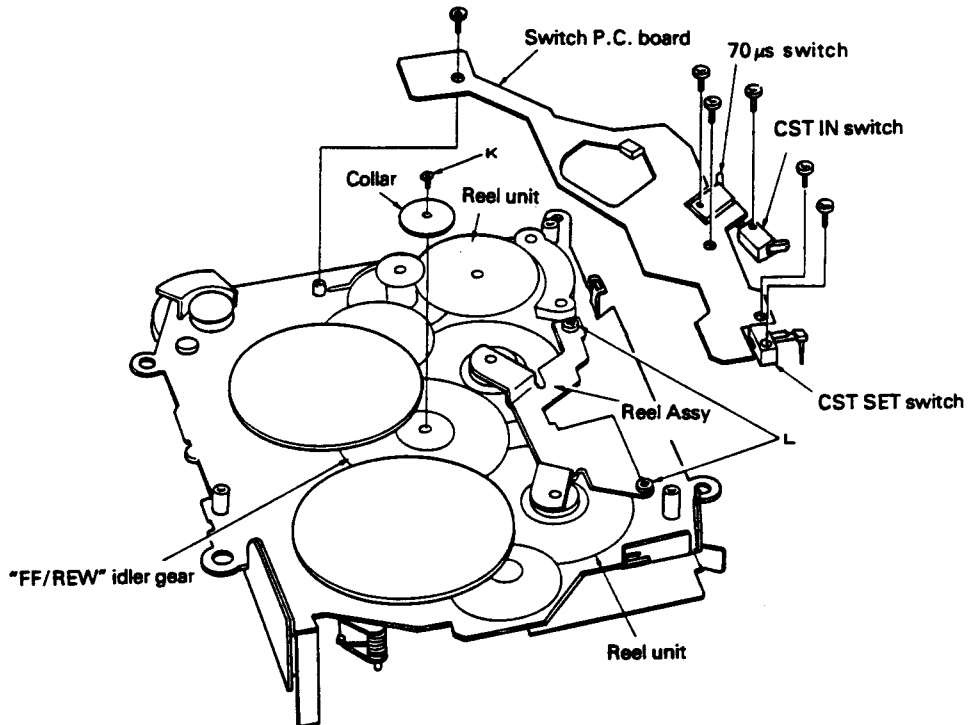

Fig. 6

2. MECHANISM DESCRIPTION

Cassette mechanism assy for CX-156/A is used in this mechanism description.

1. Outline of Mechanism

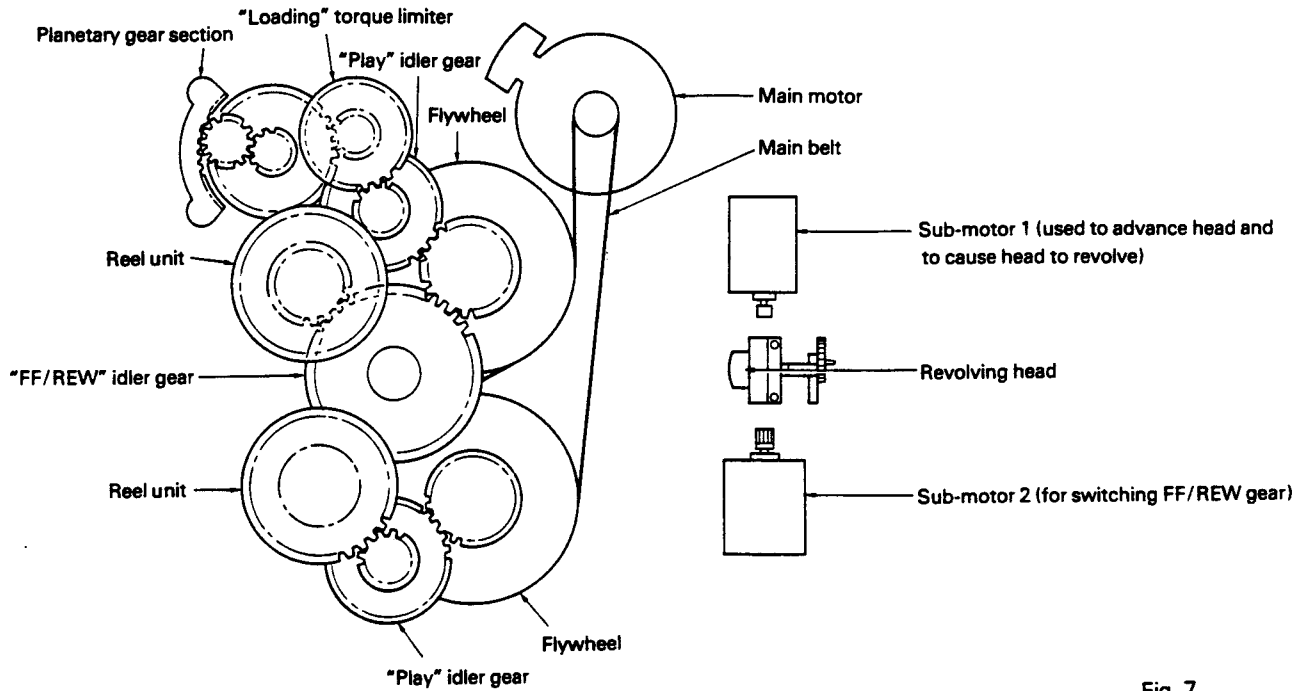

Fig. 7

2. Loading/Eject Function

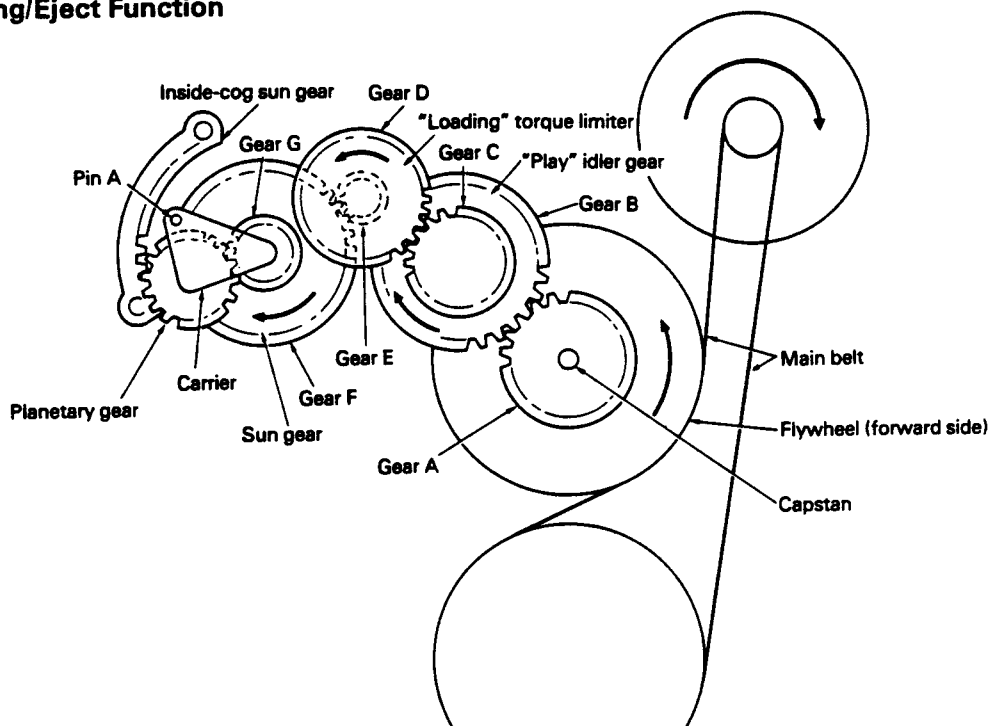

Fig. 8

3. Cassette Tape Load and Eject Mechanism

• Cassette tape loading operation

1. Push the cassette tape lightly in the direction indicated by the arrow. (As shown in Fig. 10, arm "A" and arm "B" connect to spring "A". These are also connected to common axis shaft "A", which is attached to the chassis surface and acts as a swivel. Pin "A", which is caulked to the planetary gear unit carrier, goes through the chassis and fits into the oblong hole of arm "B". Because pin "A" won't move as long as the capstan motor isn't moving, arm "B" won't move either.)
2. When a cassette tape is loaded, arm "A" moves in the direction indicated by the arrow and spring "A" loosens. Lever "A" also moves in the direction indicated by the arrow, and the catch at left of the lever releases arm "C". Arm "C" then turns counterclockwise and opens the CST IN switch. The capstan motor then begins turning forward.
3. The carrier then moves clockwise because the planetary gear moves along the inside-cog sun gear. Pin "A" which is caulked to the carrier also moves in the same direction. (Fig. 11) The movement of pin "A" is causing arm "B" to move counterclockwise. Arm "A" turns in the same fashion and the "A" unit of lever "A" draws the cassette tape in. (Fig. 9)

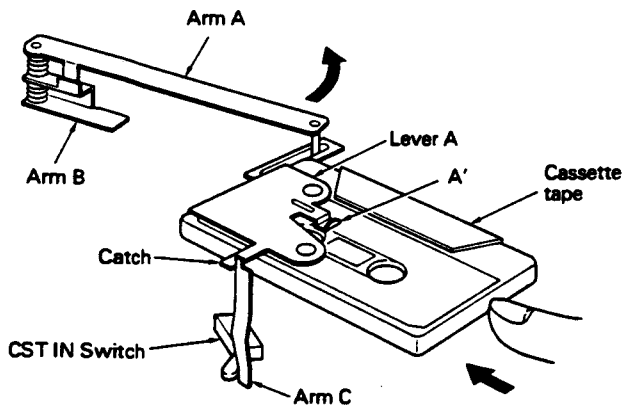

Fig. 9

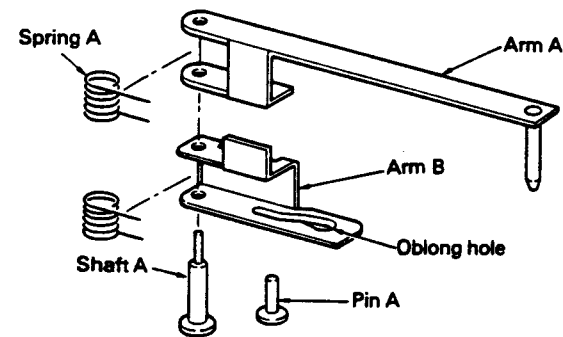

Fig. 10

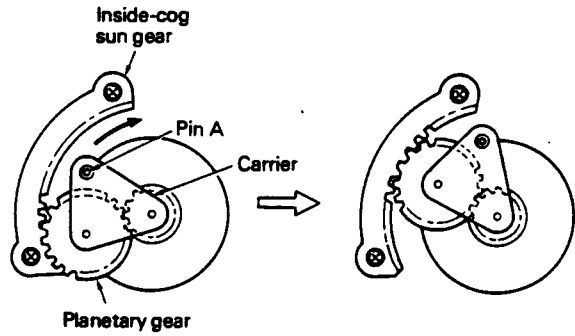

Fig. 11

4. The oblong hole of arm "B" is as shown in Fig. 12. The cassette tape draw-in process will be complete when the pin "A" degree of rotation is θ . Arm "B" will not move while the degree of rotation is θ' .

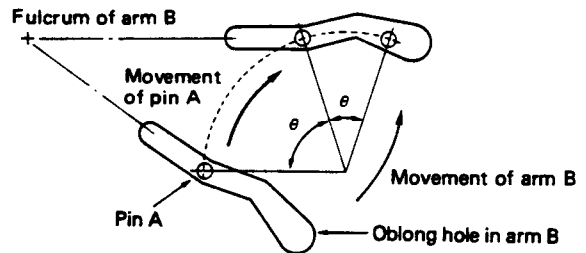

Fig. 12

5. As shown in Fig. 13, arm "C" (caulked to the chassis swivel) is fixed to pin "A" and when the degree of rotation is θ arm "C" is stationary, and when it is θ' arm "C" turns clockwise.

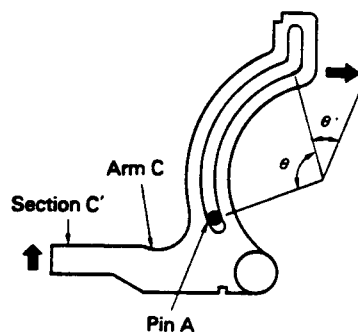

Fig. 13

6. As shown in Fig. 14, the "C" unit of arm "C" connects to the cassette arm (which suspends the cassette tape) through spring "C". The arm "C" movement described above in paragraph five makes the "C" unit move in the direction indicated by the arrow in Fig. 14. The cassette arm pushes down holder "A" by means of spring "B". The "C" unit is released when holder "A" drops down.
7. In order for the capstan motor to keep turning forward, the planetary gear disengages from the inside-cog sun gear and becomes free.

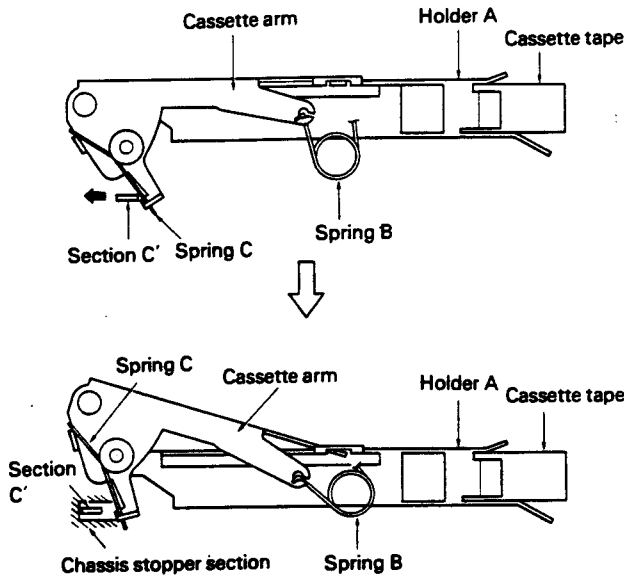

Fig. 14

• Eject operation

1. Turning on the eject switch reverses the capstan motor. As shown in Fig. 15, spring "D" places slight friction on the planetary gear which causes it to engage with the inside-cog sun gear. The cassette tape is ejected following an operation opposite to the loading operation.

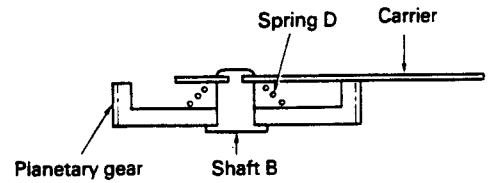

Fig. 15

4. Head Turning and Head Positioning Operations (during forward play)

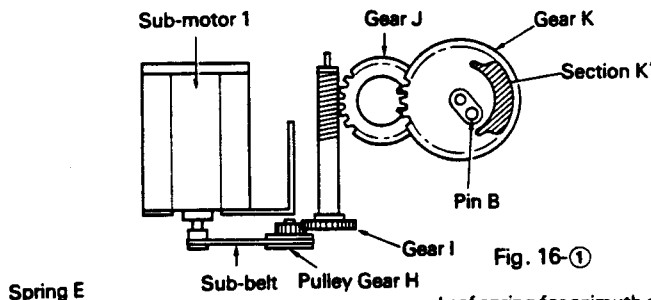

Fig. 16-①

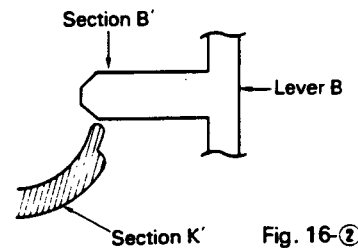

Fig. 16-②

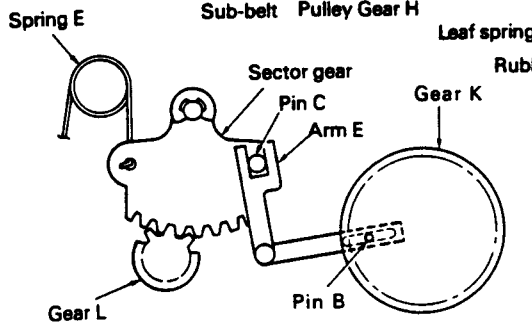

Fig. 16-③

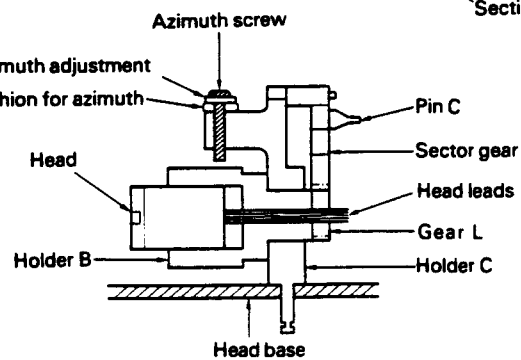

Fig. 16-④

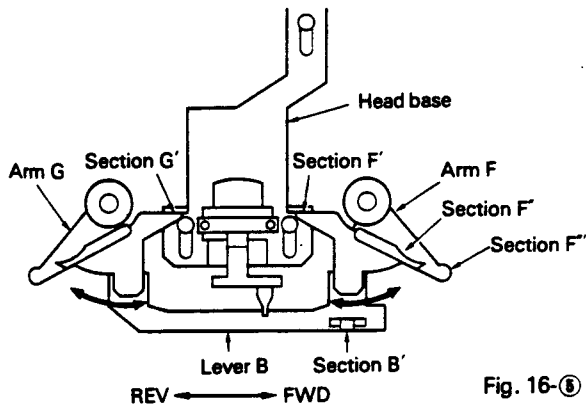

Fig. 16-8

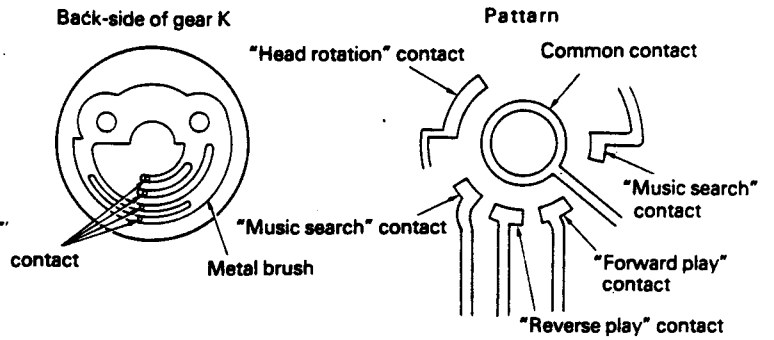

Fig. 16-9

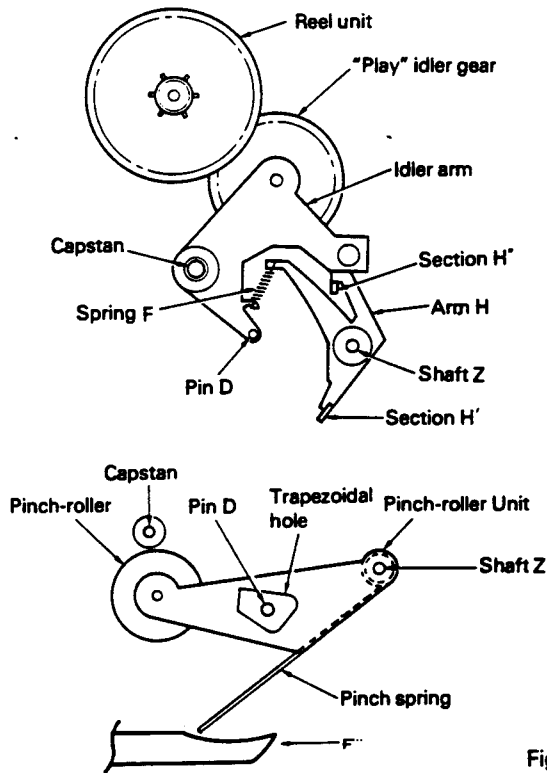

Fig. 17

1. The sub-belt from sub-motor 1 goes through pulley gear "H", gear "I", gear "J" and turns gear "K". Head turning and head base positioning take place using the "K" unit (the projecting unit) of gear "K" and pin "B". There is a metal brush attached to the back of gear "K" which detects the passing through of all patterns and common patterns and stops sub-motor 1. This controls the head positioning, the head turning, the contact pressure of the play idler gear and the contact pressure of the pinch roller.
2. Head turning at pin "B" takes place until gear "K" starts turning which brings the "K" part into contact with the lever "B", "B" part. (Fig. 16-3)
3. Pin "B" engages with the arm "E" oval opening and rotates arm "E". The arm "E" sector gear is engaged with pin "C" and this turns the head. The head rotation pattern (Fig. 16-9) performs this operation inside a certain angle.
4. When gear "K" turns it also pushes the lever "B", "B" part. The "B" part turns arm "F" and arm "G" counter-clockwise and advances head base with the arm "G", "G" part. (Fig. 16-2, 8)
5. After the head base goes beyond the MS pattern (Fig. 16-6) position, the arm "F", "F" part pushes the pinch roller unit pinch spring and presses the pinch roller down onto the capstan. (Fig. 17)
6. Simultaneously, the arm "F", "F" unit pushes the arm "H", "H" part. The "H" part lock releases when pushed, and the play idler gear comes into contact with the reel unit. Play operation begins because of this. (Fig. 16-5, Fig. 17)
7. When going from play to eject, first, the pinch roller disengages from the capstan, and then using the pinch roller unit trapezoidal hole, releases the idler arm from the reel unit by means of pin "D". After that, the "H" unit again meshes with the idler arm and the "play" idler gear stops after completely disengaging from the reel unit.

5. FF/REW Operation

1. As with the head operations a brush is attached to the back of gear "P" and using patterns and the brush, position sensing takes place and this controls the FF/REW operation.
2. Sub-motor 2 goes through gears "L", "M" and "N" and turns gear "P". When gear "P" turns, arm "J" rotates by means of arm "J". Arm "I" rotates the FF/REW idler gear and engages it with the reel unit.

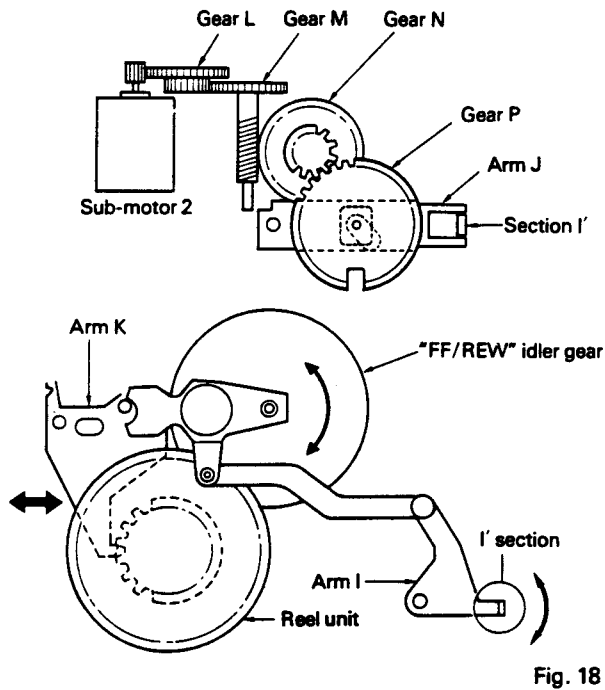

Fig. 18

3. ADJUSTMENT

3.1 AZIMUTH ADJUSTMENT

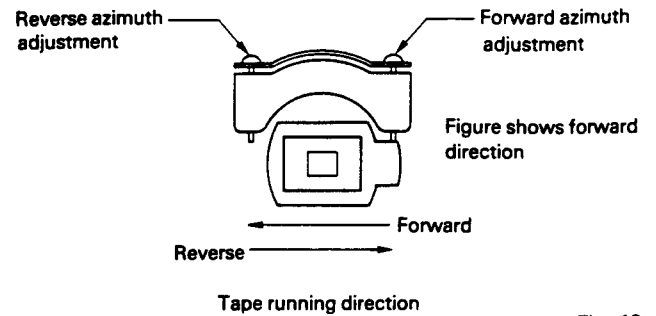

Fig. 19

• To Adjust

1. Play "A" side of STD-341A (10kHz, -20dB). Adjust each screw for maximum output in forward and reverse directions.
2. Play "B" side in forward and reverse directions to confirm adjustment.

3.2 TAPE SPEED ADJUSTMENT

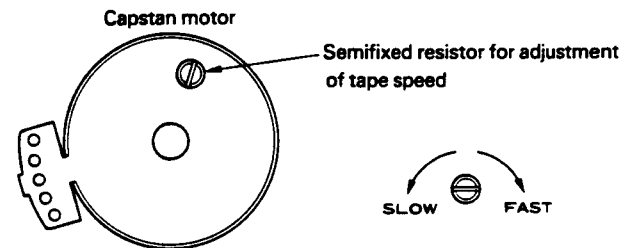

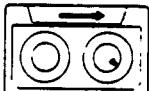
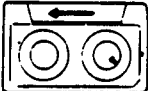

Fig. 20

• To Adjust

1. Reproduce STD-301 (3kHz, -10dB). Adjust the semifix resistor so that the frequency counter shows 3,010Hz (+30Hz, -30Hz).

3.3 CHECK POINTS OF CASSETTE MECHANISM

<p>Confirm the following items when replacing parts of the cassette mechanism.</p>	<p>■ Tape speed deviation:</p> <p>$3,000 \pm_{30}^{90}$ Hz</p> <p>(4.76 cm/s \pm_{1}^{3}%)</p> <p>Using an STD-301, measure the speed at the start and end of winding and see that a deviation remains within the limits each time. If values indicated by the pointer vary considerably, adjust to 70% of the minimum and maximum values. Measuring time shall be 5~6 seconds.</p>	<p>■ Wow and flutter:</p> <p>Less than 0.15% (WMS)</p> <p>Using an STD-301, measure the wow and flutter at the start and end of winding and take the maximum value. If values indicated by the pointer vary considerably, adjust to 70% of the minimum and maximum values. Measuring time shall be 5~6 seconds.</p>
<p>■ Fast forward and rewinding time:</p> <p>95 ~ 115 seconds</p> <p>Using a C-60, set to fast forward and rewind, and measure the time with a stop watch.</p>	<p>■ Winding torque:</p> <p>40 ~ 60g · cm</p>  <p>Using a cassette type torque meter (100 g · cm), measure the minimum value while in the play mode. Measuring time shall be 5 ~ 6 seconds.</p>	<p>■ F.F. torque:</p> <p>70 ~ 110g · cm</p>  <p>Using a cassette type torque meter (120 g · cm), measure the value when the tape stops in the F.F. mode.</p>
<p>■ REW torque:</p> <p>70 ~ 110g · cm</p>  <p>Using a cassette type torque meter (120 g · cm), measure the value when the tape stops in the REW mode.</p>	<p>■ Back tension torque:</p> <p>2.0 ~ 3.5g · cm</p>  <p>After setting in the REW mode without loading a cassette tape for 5 minutes, measure the back tension torque in the play mode, using a cassette type torque meter.</p>	<p>■ Cassette loading force:</p> <p>450 ~ 550 g</p> <p>Push the center of the cassette and measure the force with a tension meter (1 kg).</p>

4. EXPLODED VIEW

MC-Service

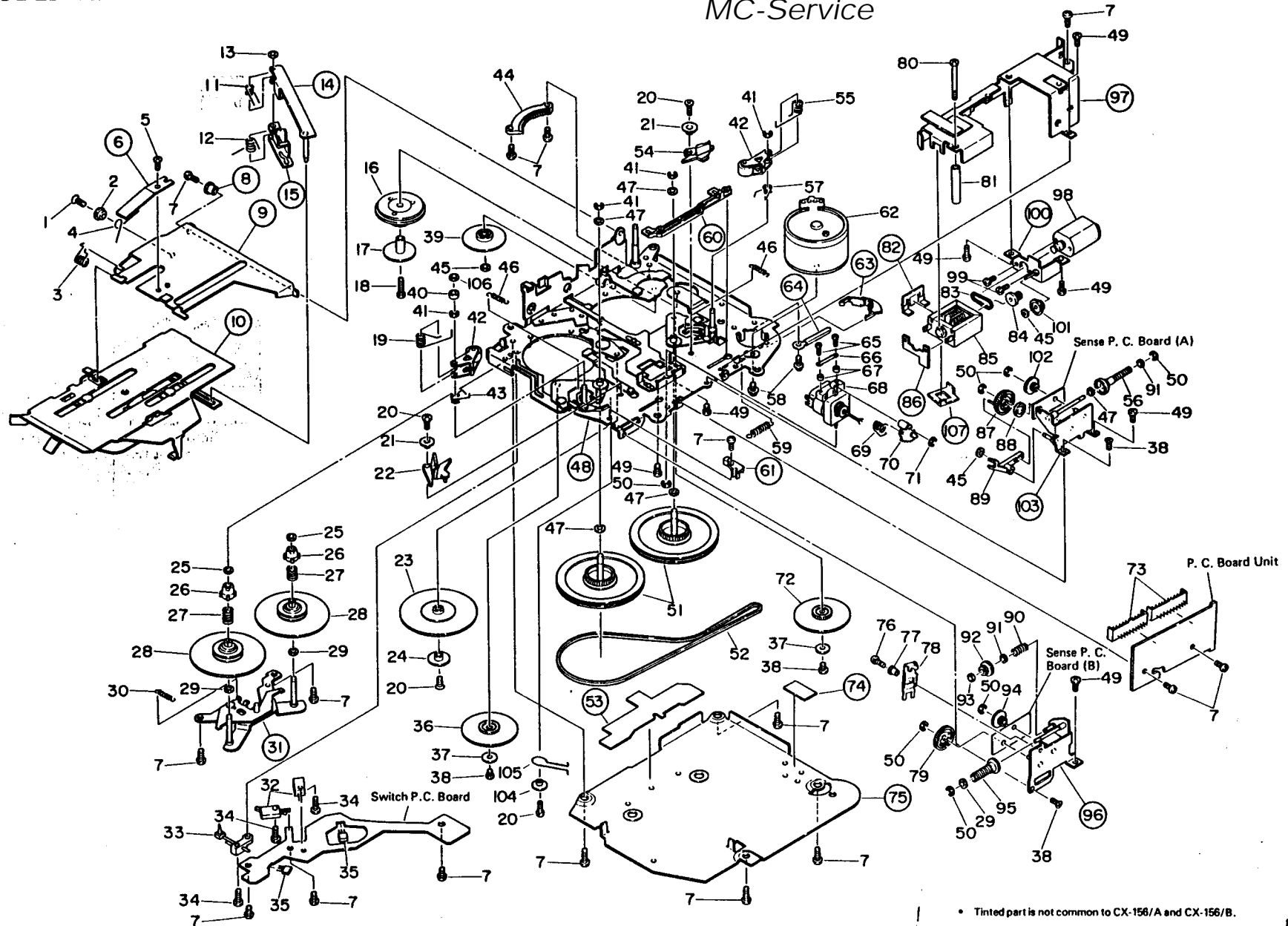

Fig. 21

NOTE:

- For your Parts Stock Control, the fast moving items are indicated with the marks ★ ★ and ★.
- ★ ★: **GENERALLY MOVES FASTER THAN ★.**
- This classification shall be adjusted by each distributor because it depends on model number, temperature, humidity, etc.*
- Parts whose parts numbers are omitted are subject to being not supplied.

Mark	No.	Part No.	Description	Mark	No.	Part No.	Description
	1.	HBA-193	Screw M1.4×3.5		53.		Insulator
	2.	CLB-691	Collar		54.	CNW-931	Arm
	3.	CBH-837	Spring		55.	CBH-831	Spring
	4.	CBH-867	Spring		56.	CNW-956	Gear
	5.	HBA-147	Screw M1.4×1.4		57.	CBH-833	Spring
	6.		Spring		58.	PMS26P030FMC	Screw
	7.	BMZ20P040FMC	Screw		59.	CBH-830	Spring
	8.		Bush		60.		Lever
	9.		Arm		61.		Spacer
	10.		Holder Unit (CX-156/A)	★ ★	62.	CXM-161	Motor (Capstan)
			Holder Unit (CX-156/B)		63.		Clamper
	11.	CBH-836	Spring (CX-156/A)		64.		Clamper
		CBH-887	Spring (CX-156/B)		65.	CBA-173	Screw M1.4×8
	12.	CBH-886	Spring		66.	CBE-114	Spring
	13.	CBF-046	Washer		67.	CNY-134	Azimuth Rubber
	14.		Arm Unit	★ ★	68.	CXD-758	Head Unit
	15.		Arm		69.	CBH-829	Spring
	16.	CXD-388	Gear Unit		70.	CNW-939	Gear
	17.	CLB-617	Collar		71.	YE15FUC	Washer
	18.	CBA-166	Screw M1.7×8		72.	CNW-943	Gear
	19.	CBH-832	Spring		73.	CKS-534	Plug
	20.	HBA-310	Screw M2×3.5		74.		Insulator
	21.	CLB-612	Collar		75.		Cover
	22.	CNW-930	Arm		76.	HBA-158	Screw M1.4×5
	23.	CNW-944	Gear		77.	CLB-750	Collar
	24.	CLB-616	Collar		78.	CNH-004	Arm
	25.	CBF-135	Washer		79.	CNW-953	Gear
	26.	CNW-932	Collar		80.	CBA-165	Screw M2
	27.	CBH-827	Spring		81.	CLB-749	Spacer
★ ★	28.	CXD-384	Reel Unit		82.		Spacer
	29.	CBF-088	Washer	★ ★	83.	CNT-114	Belt
	30.	CBH-868	Spring		84.	CNW-941	Gear
	31.		Bracket Unit	★ ★	85.	CXM-351	Motor (Gear Position)
★ ★	32.	CSN-091	Switch (70μs, CST IN)		86.		P.C. Board
★ ★	33.	CSN-089	Switch (CST SET)		87.	CNW-952	Gear
	34.	CBA-172	Screw M1.7×5.5		88.	CNN-481	Spacer
★	35.	SDME106A	Magnetic Resistive Device		89.	CNW-958	Arm
	36.	CNW-943	Gear		90.	CBH-866	Spring
	37.	CLB-615	Collar		91.	HBF-116	Washer
	38.	HBA-209	Screw M2×2		92.	CNW-954	Gear
	39.	CNW-950	Gear		93.	CBF-135	Washer
	40.	CLB-690	Roller		94.	CNY-077	Gear
	41.	EBG-001	Washer		95.	CNY-148	Gear
★ ★	42.	CXD-387	Pinch Roller Unit		96.		Holder Unit
	43.	CBH-834	Spring		97.		Guide
	44.	CNW-951	Gear	★ ★	98.	CXM-452	Motor (Head Position)
	45.	CBF-126	Washer		99.	HBA-244	Screw M1.4×1.6
	46.	CBH-835	Spring		100.		Bracket Unit
	47.	HBF-179	Washer		101.	CNY-075	Pulley
	48.		Chassis Unit (CX-156/A)		102.	CNW-955	Gear
			Chassis Unit (CX-156/B)		103.		Holder Unit
	49.	HBA-175	Screw M2×2.5		104.	CLB-760	Collar
	50.	YE12FUC	Washer		105.	CBH-893	Spring
	51.	CNW-942	Flywheel		106.	HBF-180	Washer
★ ★	52.	CNT-111	Belt		107.		Cover

5. CONNECTION DIAGRAM

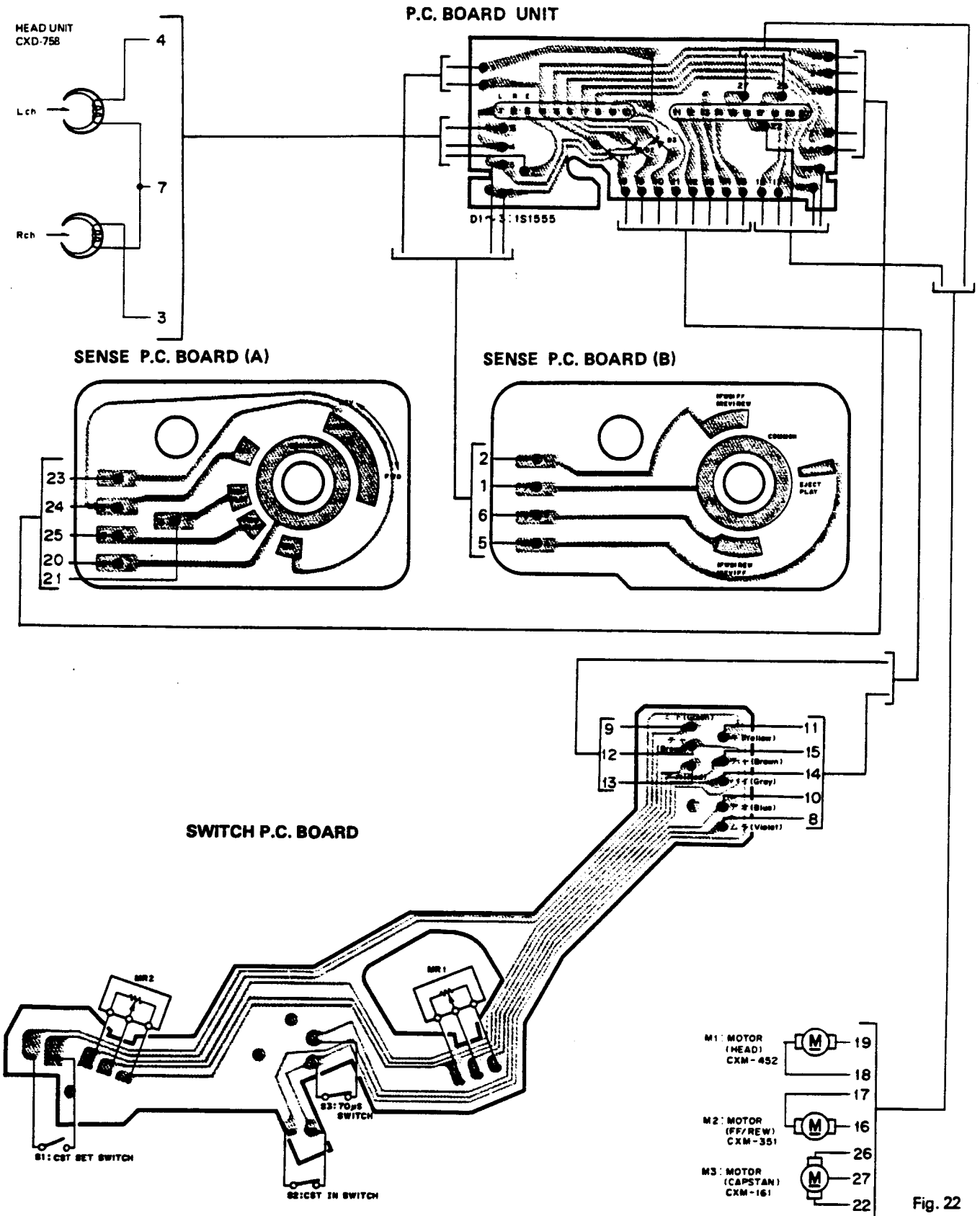

6. SCHEMATIC CIRCUIT DIAGRAM

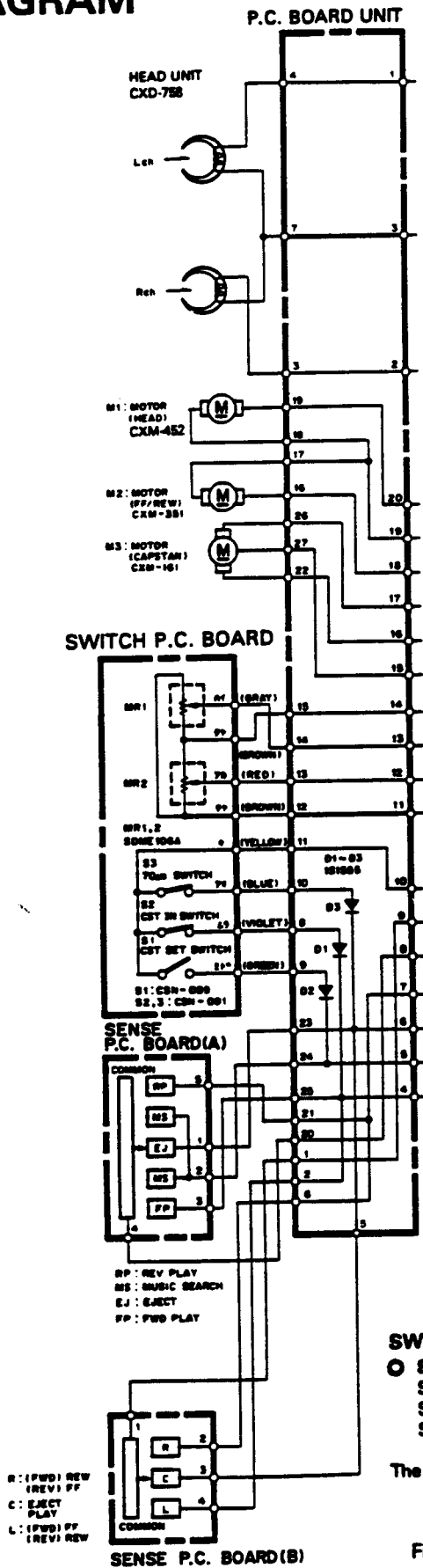

7. ELECTRICAL PARTS LIST

Switch P.C. Board

Mark	Symbol & Description	Part No.
★ ★	S1 Switch (CST SET)	CSN-089
★ ★	S2, S3 Switch (CST IN, 70 μs)	CSN-091
★	MR1, MR2 Magnetic Resistive Device	SDME108A

P.C. Board Unit

Mark	Symbol & Description	Part No.
★	D1 - D3	1S1555

Miscellaneous Parts List

Mark	Symbol & Description	Part No.
★ ★	Head Unit	CXD-758
★ ★	M1 Motor (Head)	CXM-452
★ ★	M2 Motor (Gear)	CXM-351
★ ★	M3 Motor (Capstan)	CXM-161

SWITCHES

- SWITCH P.C. BOARD
- S1: CST SET SWITCH..... ON-OFF
- S2: CST IN SWITCH..... ON-OFF
- S3: 70μs SWITCH..... ON (120μs)-OFF (70μs)

The underlined indicates the switch position.

Fig. 23

MC-Service