

# Service Manual

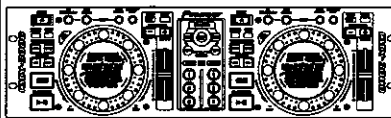

CU-V163



CMX-3000

ORDER NO.  
RRV2537

COMPACT DISC PLAYER

# CMX-3000

REMOTE CONTROLLER

# CU-V163

THIS MANUAL IS APPLICABLE TO THE FOLLOWING MODEL(S) AND TYPE(S).

Type	Model		Power Requirement	Remarks
	CMX-3000	CU-V163		
KUCXJ	○	-	AC120V	
WYXJ	○	-	AC220- 240V	
RLBXJ	○	-	AC110-120V/ 220-240V	
—	-	○	DC Power supply from other system	

## CONTENTS

1. SAFETY INFORMATION .....	2	7. GENERAL INFORMATION .....	57
2. EXPLODED VIEWS AND PARTS LIST .....	5	7.1 DIAGNOSIS .....	57
3. BLOCK DIAGRAM AND SCHEMATIC DIAGRAM .....	12	7.1.1 SERVICE MODE .....	57
4. PCB CONNECTION DIAGRAM .....	35	7.1.2 STARTING SEQUENCE .....	62
5. PCB PARTS LIST .....	50	7.1.3 DISASSEMBLY .....	63
6. ADJUSTMENT .....	55	7.2 PARTS .....	68
		7.2.1 IC .....	68
		8. PANEL FACILITIES AND SPECIFICATIONS .....	82

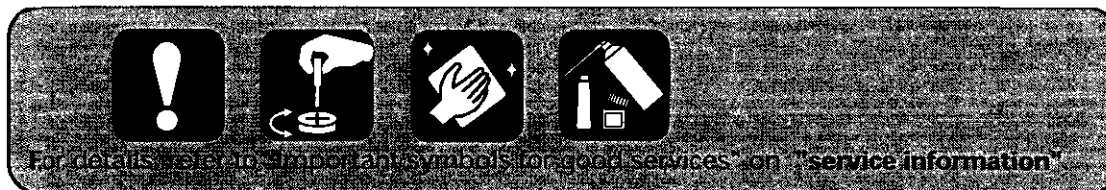

# 1. SAFETY INFORMATION

This service manual is intended for qualified service technicians; it is not meant for the casual do-it-yourselfer. Qualified technicians have the necessary test equipment and tools, and have been trained to properly and safely repair complex products such as those covered by this manual. Improperly performed repairs can adversely affect the safety and reliability of the product and may void the warranty. If you are not qualified to perform the repair of this product properly and safely, you should not risk trying to do so and refer the repair to a qualified service technician.



**WARNING**

This product contains lead in solder and certain electrical parts contain chemicals which are known to the state of California to cause cancer, birth defects or other reproductive harm.

Health & Safety Code Section 25249.6 – Proposition 65



**NOTICE**

(FOR CANADIAN MODEL ONLY)

Fuse symbols  (fast operating fuse) and/or  (slow operating fuse) on PCB indicate that replacement parts must be of identical designation.

**REMARQUE**

(POUR MODÈLE CANADIEN SEULEMENT)

Les symboles de fusible  (fusible de type rapide) et/ou  (fusible de type lent) sur CCI indiquent que les pièces de remplacement doivent avoir la même désignation.

**(FOR USA MODEL ONLY)**

## 1. SAFETY PRECAUTIONS

The following check should be performed for the continued protection of the customer and service technician.

### LEAKAGE CURRENT CHECK

Measure leakage current to a known earth ground (water pipe, conduit, etc.) by connecting a leakage current tester such as Simpson Model 229-2 or equivalent between the earth ground and all exposed metal parts of the appliance (input/output terminals, screwheads, metal overlays, control shaft, etc.). Plug the AC line cord of the appliance directly into a 120V AC 60 Hz outlet and turn the AC power switch on. Any current measured must not exceed 0.5 mA.

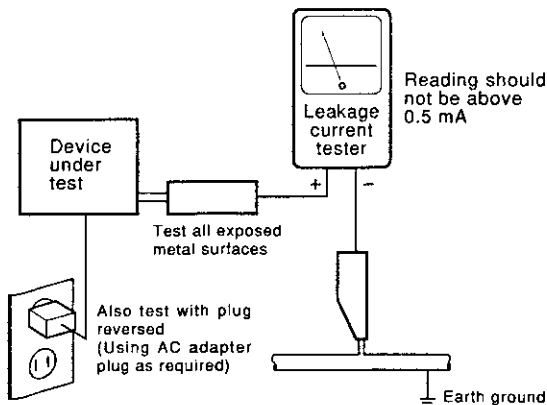

**ANY MEASUREMENTS NOT WITHIN THE LIMITS OUTLINED ABOVE ARE INDICATIVE OF A POTENTIAL SHOCK HAZARD AND MUST BE CORRECTED BEFORE RETURNING THE APPLIANCE TO THE CUSTOMER.**

## 2. PRODUCT SAFETY NOTICE

Many electrical and mechanical parts in the appliance have special safety related characteristics. These are often not evident from visual inspection nor the protection afforded by them necessarily can be obtained by using replacement components rated for voltage, wattage, etc. Replacement parts which have these special safety characteristics are identified in this Service Manual.

Electrical components having such features are identified by marking with a  $\Delta$  on the schematics and on the parts list in this Service Manual.

The use of a substitute replacement component which does not have the same safety characteristics as the PIONEER recommended replacement one, shown in the parts list in this Service Manual, may create shock, fire, or other hazards.

Product Safety is continuously under review and new instructions are issued from time to time. For the latest information, always consult the current PIONEER Service Manual. A subscription to, or additional copies of, PIONEER Service Manual may be obtained at a nominal charge from PIONEER.

**IMPORTANT**

THIS PIONEER APPARATUS CONTAINS LASER OF CLASS 1. SERVICING OPERATION OF THE APPARATUS SHOULD BE DONE BY A SPECIALLY INSTRUCTED PERSON.

**LASER DIODE CHARACTERISTICS**

MAXIMUM OUTPUT POWER: 5 mW  
WAVELENGTH: 780 - 785 nm

**WARNING !**

The AEL(accessible emission level) of the laser power output is less than CLASS 1 but the laser component is capable of emitting radiation exceeding the limit for CLASS 1.  
A specially instructed person should servicing operation of the apparatus.

**LABEL CHECK**

**CMX-3000/ WYXJ type Only**

**VARO!**  
Avattuessa ja suojalukitus ohitettessa olet alttiina näkymättömälle laser säteilylle. Älä katso säteeseen.  
**VARNING!**  
Öppnning laserstrålning när denna del är öppnad och spårren är urkopplad. Betrakta ej strålen.  
PRW1233

**ADVARSEL**  
USYNLIG LASERSTRÅLING VED ÅBNING MÅR SIKKERHED SAF-BRYDERE ER UDE AF FUNKTION. UNDGÅ UDSÆTTELSE FOR STRÅLING.  
**VORSICHT!**  
UNSIHTBARE LASER-STRÅHLUNG TRITT AUS, WENN DECKEL (ODER KLAPPE) GEÖFFNET IST! NICHT DEM STRAHL AUSSETZEN!  
VRW1084

**CMX-3000/ RLBXJ type Only**

**CAUTION** : LASER RADIATION WHEN COVER IS OPEN. AVOID EXPOSURE TO RADIATION.  
**VORSICHT** : LASERSTRÄHLUNG, WENN ABDECKUNG GEÖFFNET NICHT DEM STRAHL AUSSETZEN!  
**ADVARSEL** : LASERSTRÄHLUNG VED ÅBNING UNDGÅ UDSÆTTELSE FOR STRÄHLUNG.  
**VARNING** : LASERSTRÄHLUNG NÄR DENNA DEL ÄR ÖPPNAD BETRÄKTA EJ STRÄLLEN.  
**VARO!** : AVATTAESSA AUKUSTUUT LASERISÄTELYLLE ÄLÄ KATSO SÄTEESEEN.  
주의 : 개폐를 할때, 레이저 광선이 방출되므로, 관성의 방출에 노출될 정도로 주의할 것.  
PRW 3180

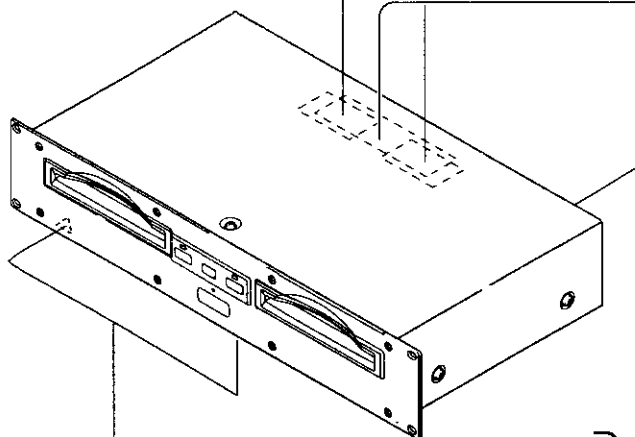

CMX-3000/ KUCXJ type Only

**CLASS 1 LASER PRODUCT**

Printed on the Rear Panel.

**Additional Laser Caution**

- 1. Laser Interlock Mechanism**  
The position of the switch (S801, S901) for detecting loading completion is detected by the system microprocessor, and the design prevents laser diode oscillation when the switch is not in LPS1 terminal side (when the mechanism is not clamped and LPS1 signal is high level.) Thus, the interlock will no longer function if the switch is deliberately set to LPS1 terminal side. ( if LPS1 signal is low level ).  
In the test mode\* the interlock mechanism will not function. Laser diode oscillation will continue, if pin 9 of TA2153FN (IC1010, IC1003) on the MAIN ASSY is connected to GND, or pin 10 of IC1010, IC1003 (LDON) is connected to low level (ON), or else the terminals of Q1003, Q1229 are shorted to each other (fault condition).  
Note: S801, IC1010 and Q1003 (Player A Side)  
S901, IC1003 and Q1229 (Player B side)
- 2. When the cover is opened, close viewing of the objective lens with the naked eye will cause exposure to a class 1 laser beam.**

\* : Refer to page 55.

## ■ SERVICE INFORMATION

### [ Important symbols for good services ]

In this manual, the symbols shown-below indicate that adjustments, settings or cleaning should be made securely. When you find the procedures bearing any of the symbols, be sure to fulfill them:

#### 1. Product safety



You should conform to the regulations governing the product (safety, radio and noise, and other regulations), and should keep the safety during servicing by following the safety instructions described in this manual.

#### 2. Adjustments



To keep the original performances of the product, optimum adjustments or specification confirmation is indispensable. In accordance with the procedures or instructions described in this manual, adjustments should be performed.

#### 3. Cleaning



For optical pickups, tape-deck heads, lenses and mirrors used in projection monitors, and other parts requiring cleaning, proper cleaning should be performed to restore their performances.

#### 4. Shipping mode and shipping screws



To protect the product from damages or failures that may be caused during transit, the shipping mode should be set or the shipping screws should be installed before shipping out in accordance with this manual, if necessary.

#### 5. Lubricants, glues, and replacement parts



Appropriately applying grease or glue can maintain the product performances. But improper lubrication or applying glue may lead to failures or troubles in the product. By following the instructions in this manual, be sure to apply the prescribed grease or glue to proper portions by the appropriate amount. For replacement parts or tools, the prescribed ones should be used.

## [ NOTES ON SERVICING ]

### ■ CLEANING



Before shipping out the product, be sure to clean the following positions by using the prescribed cleaning tools:

Position to be cleaned	Cleaning tools
Pickup lenses	Cleaning liquid : GEM1004 Cleaning paper : GED-008

## 2. EXPLODED VIEWS AND PARTS LIST

- NOTES:**
- Parts marked by "NSP" are generally unavailable because they are not in our Master Spare Parts List.
  - The  $\Delta$  mark found on some component parts indicates the importance of the safety factor of the part. Therefore, when replacing, be sure to use parts of identical designation.
  - Screws adjacent to  $\blacktriangledown$  mark on the product are used for disassembly.
  - For the applying amount of lubricants or glue, follow the instructions in this manual. (In the case of no amount instructions, apply as you think it appropriate.)

### 2.1 PACKING

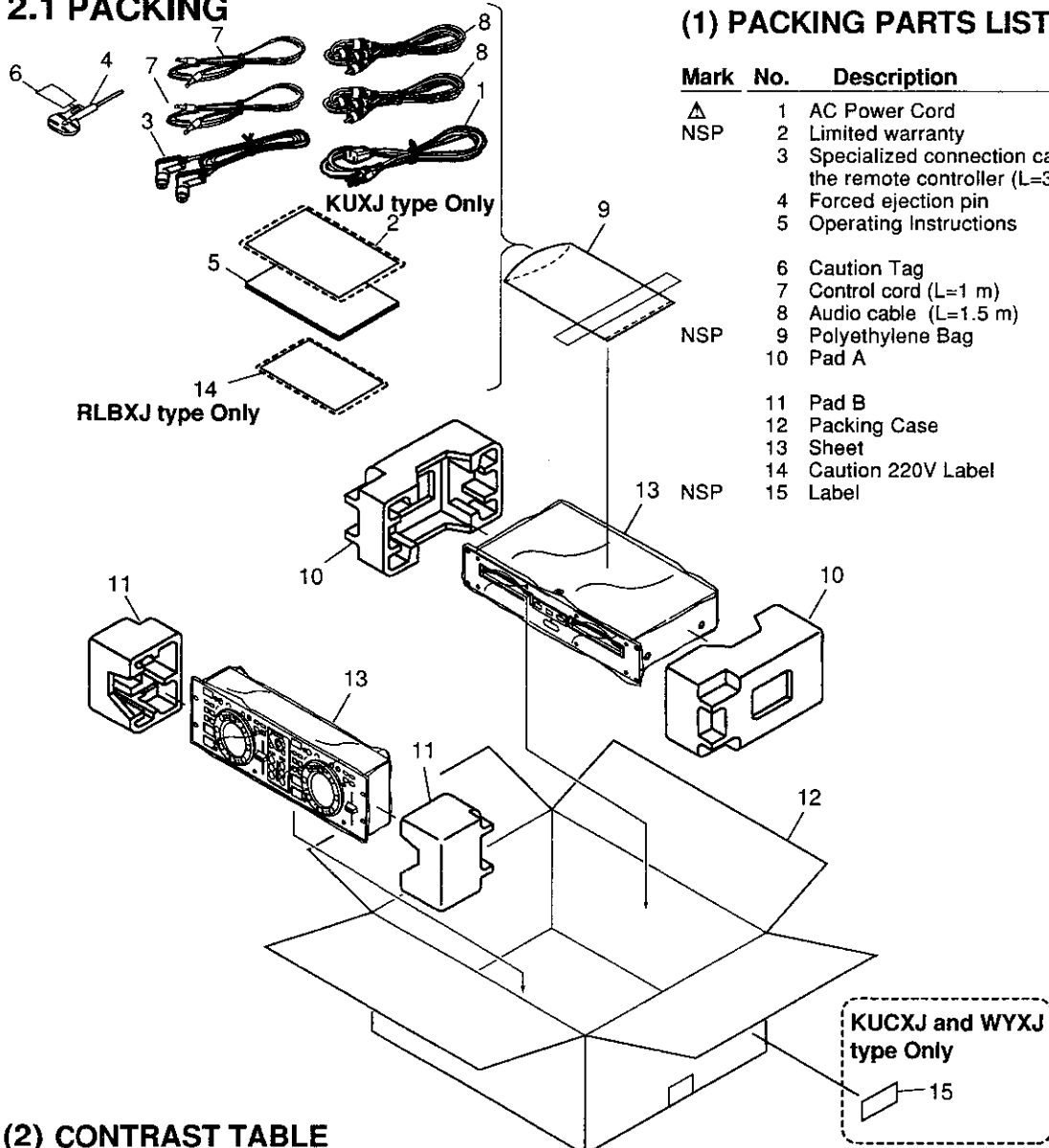

### (1) PACKING PARTS LIST

Mark	No.	Description	Part No.
$\Delta$	1	AC Power Cord	See Contrast table (2)
NSP	2	Limited warranty	See Contrast table (2)
	3	Specialized connection cable for the remote controller (L=3 m)	DDE1122
	4	Forced ejection pin	DEX1013
	5	Operating Instructions	See Contrast table (2)
	6	Caution Tag	DRW1897
	7	Control cord (L=1 m)	PDE1267
	8	Audio cable (L=1.5 m)	VDE1064
NSP	9	Polyethylene Bag	Z21-038
	10	Pad A	DHA1529
	11	Pad B	DHA1530
	12	Packing Case	See Contrast table (2)
	13	Sheet	RHX1006
	14	Caution 220V Label	See Contrast table (2)
NSP	15	Label	See Contrast table (2)

### (2) CONTRAST TABLE

CMX-3000/KUXJ, WYXJ and RLBXJ are constructed the same except for the following:

Mark	No.	Symbol and Description	Part No.			Remarks
			KUCXJ Type	WYXJ Type	RLBXJ Type	
$\Delta$ NSP	1	AC Power Cord	ADG7022	ADG1154	ADG1154	
	2	Limited warranty	ARY7043	Not used	Not used	
	5	Operating Instructions (English)	DRB1307	Not used	Not used	
	5	Operating Instructions (English/ French/ German/ Italian/ Dutch/ Spanish)	Not used	DRB1306	Not used	
	5	Operating Instructions (English/ Spanish/ Chinese)	Not used	Not used	DRB1308	
NSP	12	Packing Case	DHG2160	DHG2158	DHG2161	
	14	Caution 220V Label	Not used	Not used	ARR1003	
	15	Label	VRW1629	VRW1629	Not used	

# CMX-3000, CU-V163

## 2.2 EXTERIOR SECTION

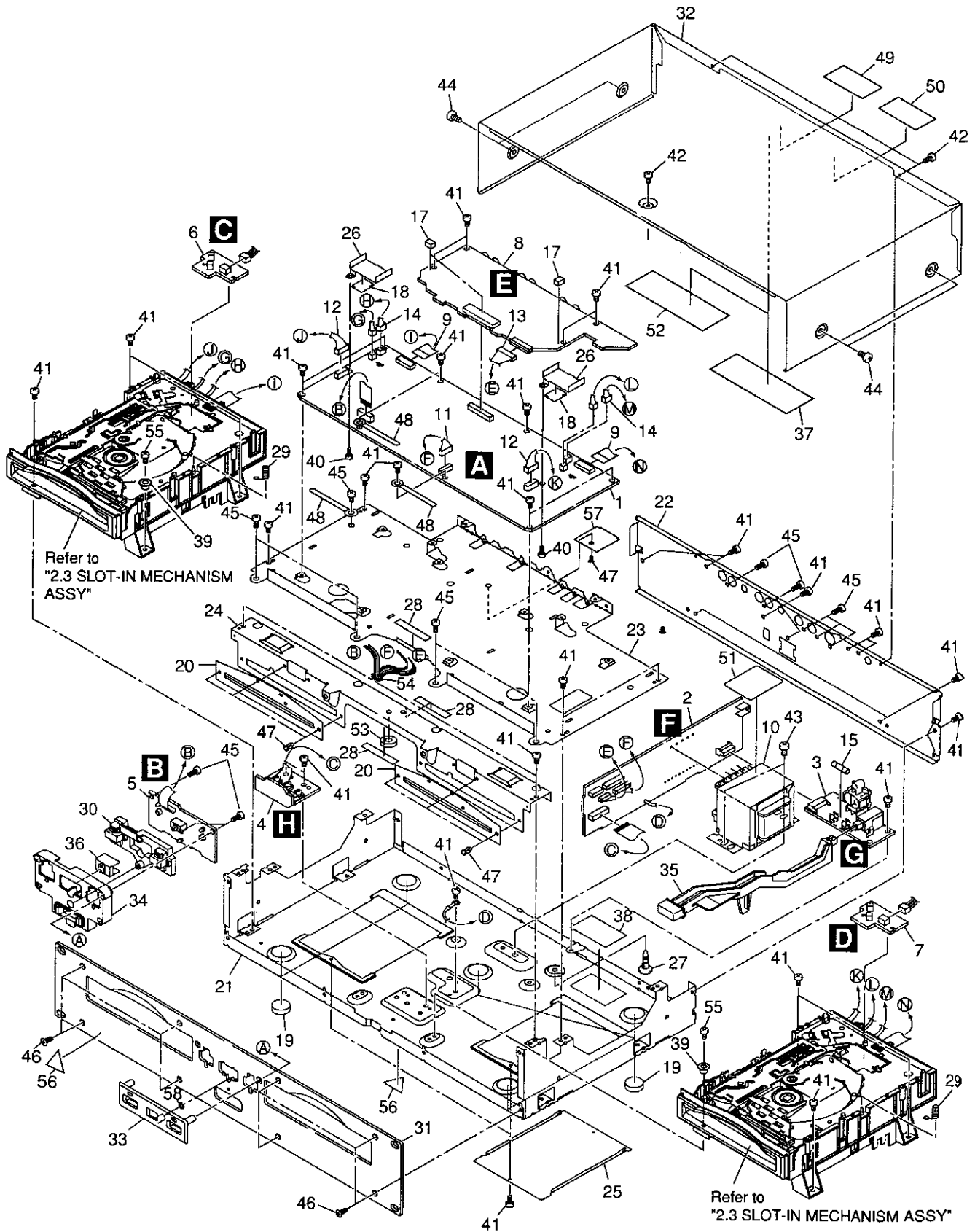

(1) EXTERIOR SECTION PARTS LIST

Mark	No.	Description	Part No.	Mark	No.	Description	Part No.
	1	MAIN ASSY	DWG1556		31	Front Panel	DNB1098
	2	PWRB ASSY	See Contrast table (2)		32	Bonnet Case	DNE1409
	3	ACIN ASSY	See Contrast table (2)		33	Function Panel	DNK3944
	4	REGB ASSY	See Contrast table (2)		34	Power Knob Caver	DNK3945
	5	FRSW ASSY	DWS1314		35	Power Knob	DNK3946
	6	SLM1 ASSY	DWS1315		36	Slide SW Knob	DNK3947
	7	SLM2 ASSY	DWS1316		37	65 Label	See Contrast table (2)
	8	JACB ASSY	See Contrast table (2)	NSP	38	Label	VRW-548
	9	Leadcard 16p	DDD1194		39	POM Bush (M3)	DEC2397
△	10	Power Transformer	See Contrast table (2)		40	Screw	BBZ26P060FMC
	11	Connector Ass'y	PF05FE-D17		41	Screw	BBZ30P060FMC
	12	ConnectOr Ass'y (6p)	PF06PP-B47		42	Screw	BBZ30P060FZK
	13	Connector Assy	PF09EE-D25		43	Screw	BBZ40P060FMC
	14	Connector Ass'y	PG03KK-E15		44	Screw	BBZ40P060FZK
△	15	Fuse (FU101)	See Contrast table (2)		45	Screw	BPZ30P080FZK
	16	•••••			46	Screw	CBZ30P080FZK
	17	Rubber Spacer	DEB1455		47	Rivet (Plastic)	RBM-003
NSP	18	Silicon Rubber D5 L	DEB1456		48	Cord Clamper (Steel)	RNH-184
	19	Insulator	DEC2348		49	Caution Label HE	See Contrast table (2)
	20	Front Sheet B	DEC2467		50	Caution Label	See Contrast table (2)
NSP	21	Chassis	DNA1277		51	Trans Sheet	DEC2280
	22	Rear Panel	See Contrast table (2)		52	Caution Label	See Contrast table (2)
	23	PCB Frame	DNH2502		53	Screw Guard	DEB1447
	24	Panel Stay	DNH2503		54	Binder	ZCA-SKB90BK
	25	Bottom Plate	DNH2505		55	Screw	BBZ30P080FMC
	26	Heat Sink	DNH2508	NSP	56	Caution Label	See Contrast table (2)
	27	Locking Card Spacer	VEC1596		57	Protect Sheet	See Contrast table (2)
	28	Sheet	DED1159		58	Spacer (PEE)	DEC2470
	29	Earth Spring	DBH1398				
	30	Eject Knob	DEB1503				

(2) CONTRAST TABLE

CMX-3000/KUXJ, WYXJ and RLBXJ are constructed the same except for the following:

Mark	No.	Symbol and Description	Part No.			Remarks
			KUCXJ Type	WYXJ Type	RLBXJ Type	
	2	PWRB ASSY	DWR1345	DWR1345	DWR1348	
	3	ACIN ASSY	DWR1349	DWR1346	DWR1346	
	4	REGB ASSY	DWR1357	DWR1347	DWR1347	
	8	JACB ASSY	DWX2214	DWX2200	DWX2200	
△	10	Power Transformer (AC120V)	DTT1161	Not used	Not used	
△	10	Power Transformer (AC220-240V)	Not used	DTT1160	Not used	
△	10	Power Transformer (AC110-120V/220-240V)	Not used	Not used	DTT1162	
△	15	Fuse (FU101: 1.6A)	REK1077	Not used	Not used	
△	15	Fuse (FU101: 1.0A)	Not used	REK1022	REK1022	
	22	Rear Panel	DNC1586	DNC1585	DNC1587	
	37	65 Label	ARW7050	Not used	Not used	
	49	Caution Label HE	Not used	PRW1233	Not used	
	50	Caution Label	Not used	VRW1094	Not used	
	52	Caution Label	Not used	Not used	DRW2102	
NSP	56	Caution Label	DRW1975	Not used	Not used	
	57	Protect Sheet	Not used	DEC2466	DEC2466	

2.3 SLOT-IN MECHANISM SECTION

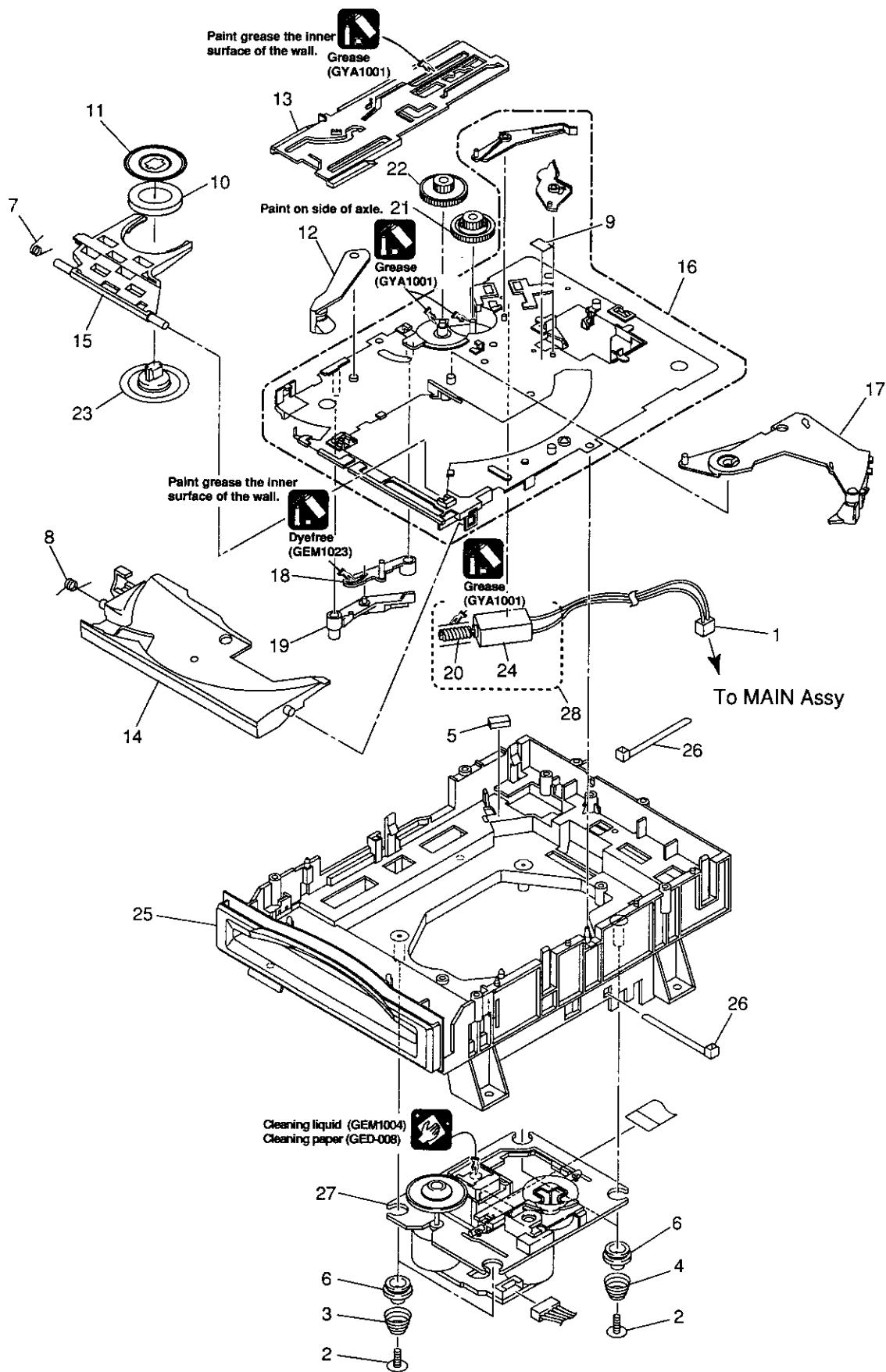



● SLOT-IN MECHANISM SECTION PARTS LIST

Mark	No.	Description	Part No.
	1	Connector Ass'y	DKP3565
	2	Float Fastener	DBA1139
	3	Float Spring F	DBH1491
	4	Float Spring R	DBH1492
	5	Spacer Por (T3)	DEB1467
	6	Float Rubber	DEB1506
	7	Clamp Spring	DBH1374
	8	Guide Spring	DBH1375
	9	Sw.Lever Spacer (Pet)	DEC2420
	10	Clamp Magnet	DMG1008
	11	Yoke	DNH2504
	12	Loading Lever	DNK3406
	13	Main Cam	DNK3407
	14	Disc Guide	DNK3478
	15	Clamp Arm	DNK3576
	16	Loading Base Assy-S	DEA1022
	17	Eject Lever	DNK3684
	18	Lever AP	DNK3835
	19	Lever BP	DNK3836
NSP	20	Worm Gear	DNK3410
	21	Loading Gear	DNK3409
	22	Drive Gear	DNK3565
	23	Clamper	DNK3949
NSP	24	Loading Motor	DXM1173
	25	Mecha Base	DNK3948
	26	Binder	ZCA-SKB90BK
	27	CD Mechanism	DA11T3CNPIO
	28	Loading Motor Assy-S	DXX2510



● REMOTE CONTROLLER (CU-V163) PARTS LIST

Mark	No.	Description	Part No.
	1	CNTA ASSY	DWG1551
	2	CNTB ASSY	DWG1552
	3	CNNB ASSY	DWG1553
	4	PHTA ASSY	DWG1554
	5	PHTB ASSY	DWG1555
	6	Screw	ABA7022
	7	CR Spacer	DEB1524
	8	Jog Sheet A	DEC2468
	9	Slide VR Packing	DED1157
	10	J Magnet	DMG1006
	11	Rear Panel	DNC1590
	12	Magnet Stay	DNF1668
	13	Earth Plate	DNH2506
	14	Retainer	DNK3952
	15	Panel Base	DNK3953
	16	Jog Ring	DNK3954
	17	Screw (Steel)	PBA1096
	18	Foot (Rubber)	REC1263
	19	Steel Ball	VNX1006
	20	Select Knob 1	DEB1504
	21	Select Knob 2	DEB1505
	22	Control Panel	DNB1099
	23	Jog Dial	DNK3950
	24	Display Plate	DNK3951
	25	Slide Knob	DNK3955
	26	65 Label	ARW7050
	27	Screw	BBZ30P060FMC
	28	Screw	BPZ30P080FZK
	29	Screw	CBZ30P080FZK
	30	Washer	WH30FUC

### 3. BLOCK DIAGRAM AND SCHEMATIC DIAGRAM

#### 3.1 BLOCK DIAGRAM

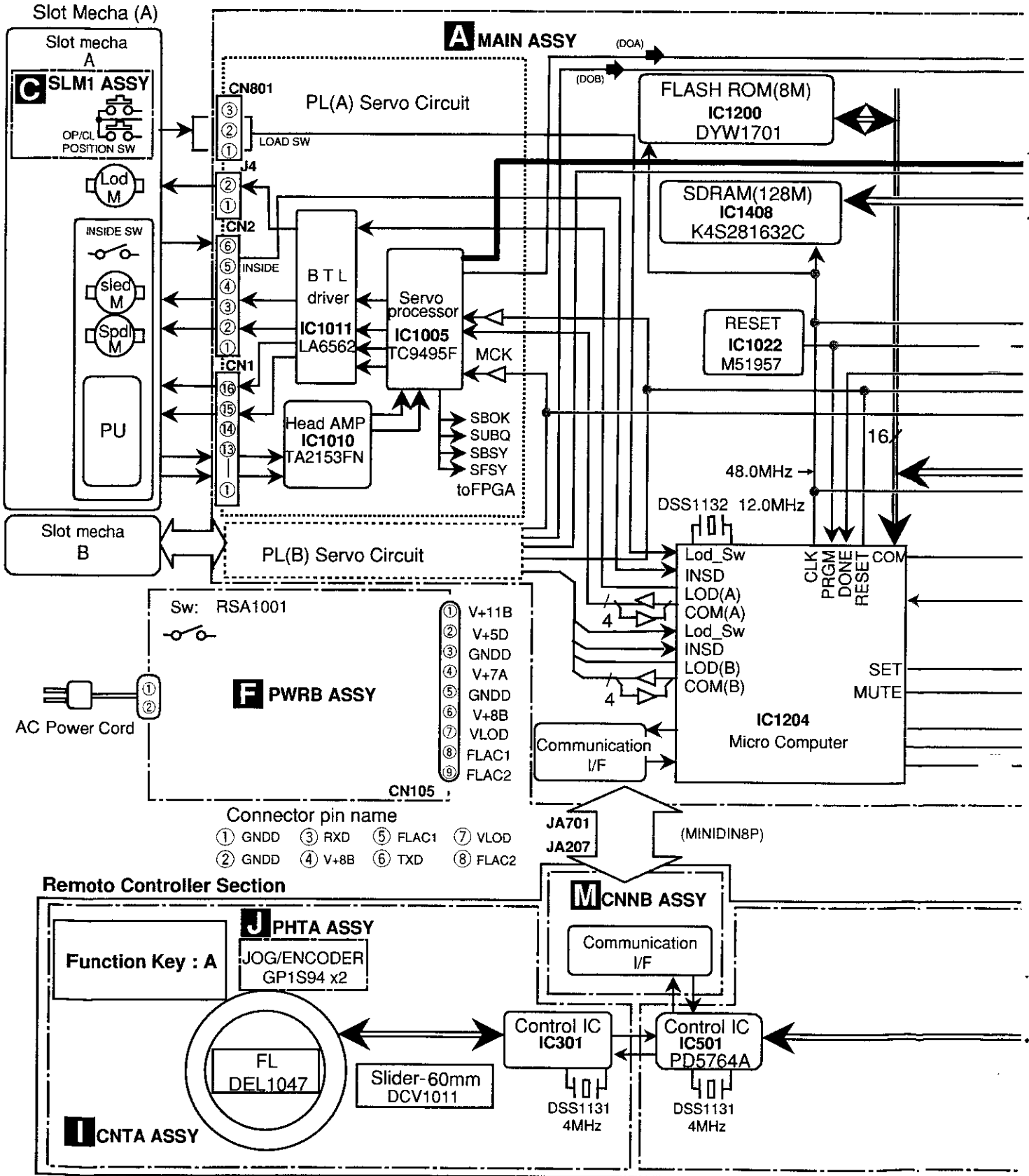

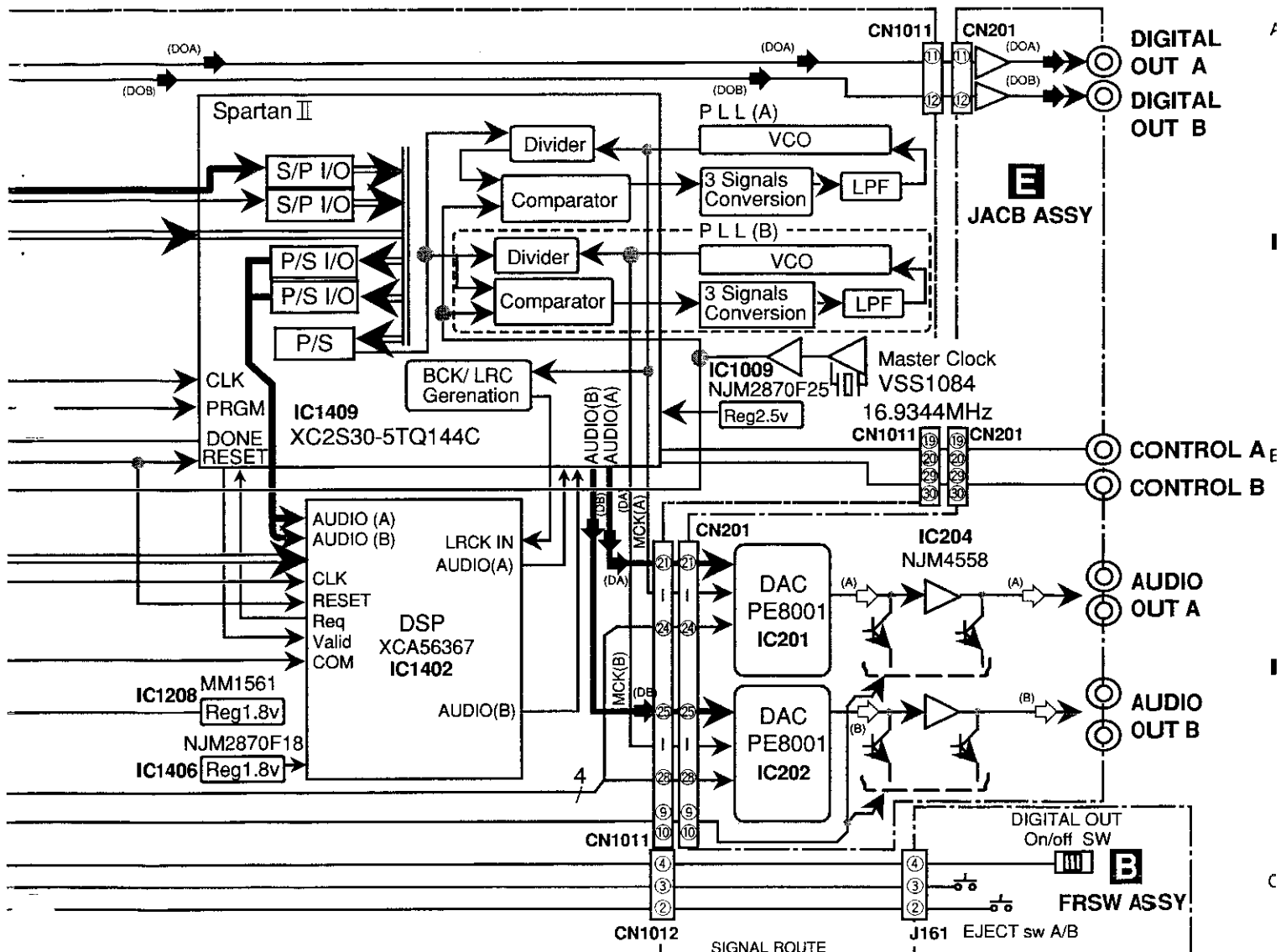

- SIGNAL ROUTE**
- (A) : PB A AUDIO SIGNAL
  - (B) : PB B AUDIO SIGNAL
  - (DA) : DIGITAL DATA A SIGNAL
  - (DB) : DIGITAL DATA B SIGNAL
  - (DOA) : DIGITAL AUDIO A SIGNAL
  - (DOB) : DIGITAL AUDIO B SIGNAL

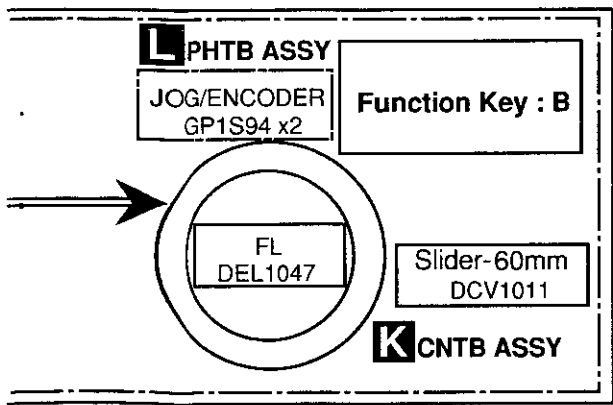

**3.2 OVERALL WIRING DIAGRAM**

**CONTROLLER (CU-V163)**

**TWIN PLAYER**

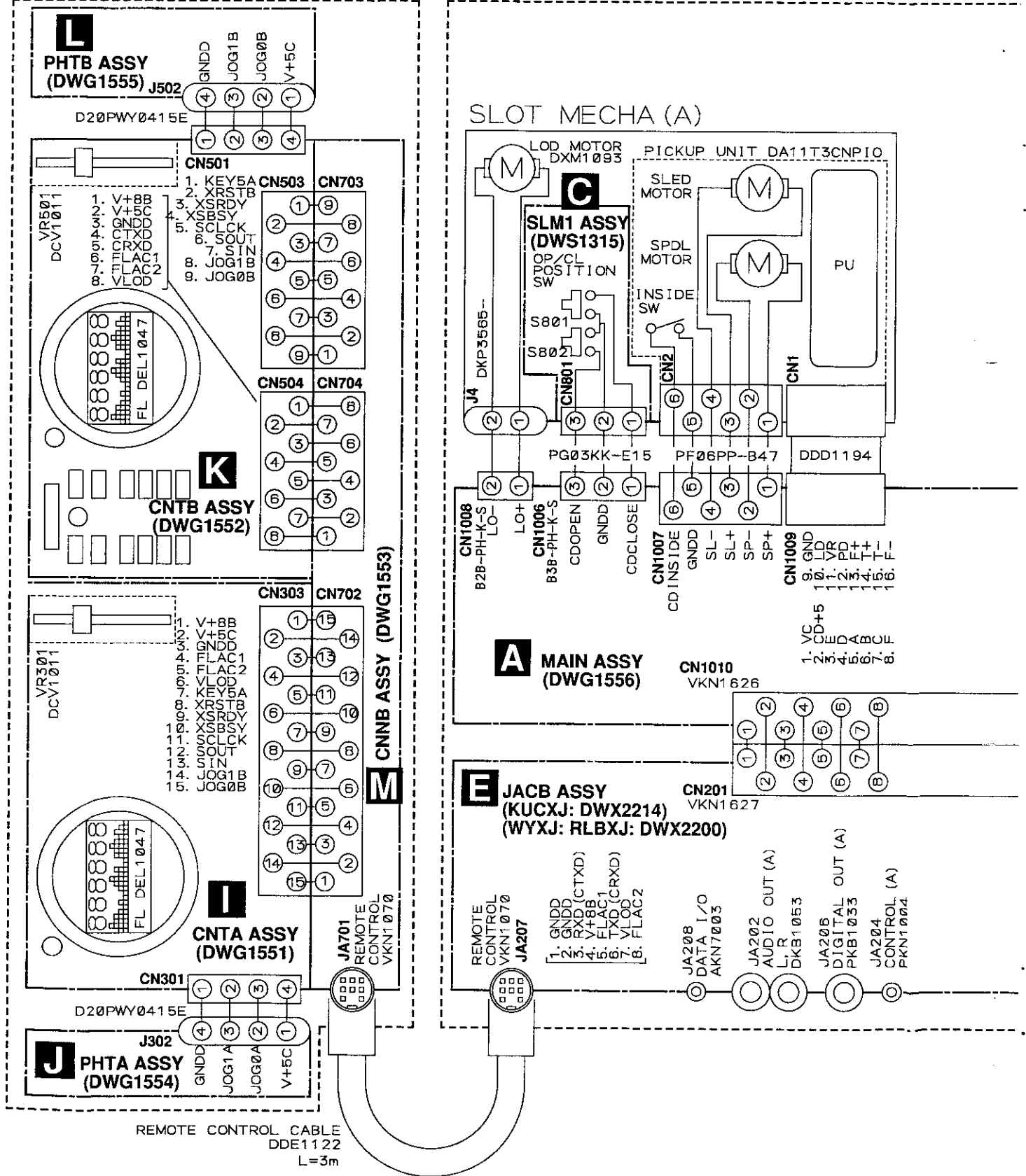

Note : When ordering service parts, be sure to refer to "EXPLODED VIEWS and PARTS LIST" or "PCB PARTS LIST".

THE  $\Delta$  MARK FOUND ON SOME COMPONENT PARTS INDICATES THE IMPORTANCE OF THE SAFETY FACTOR OF THE PARTS. THEREFORE, WHEN REPLACING, BE SURE TO USE PARTS OF IDENTICAL DESIGNATION.

CAUTION FOR CONTINUED PROTECTION AGAINST RISK OF FIRE, REPLACE WITH SAME TYPE AND RATINGS ONLY.

SLOT MECHA (B)

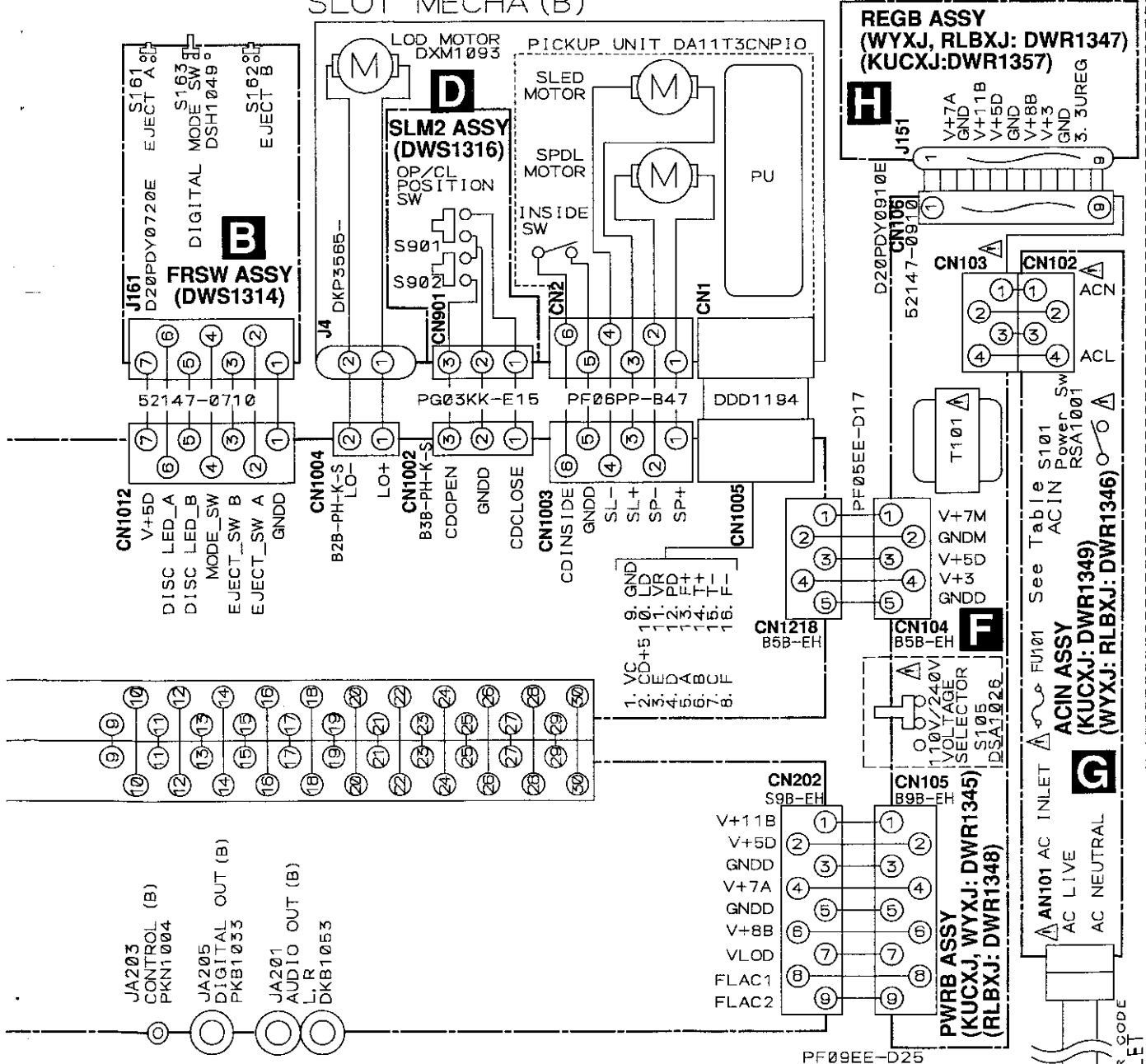

Table

CAT.	AC POWER CODE	AC INLET AN101	POWER TRANS. T101	FUSE FU101	POWER REQUIREMENT
WYXJ	ADG1154	BKP1046	DTT1180	REK1022 T1AL 250V	AC220-240V 60Hz
RLBXJ	ADG1154	BKP1046	DTT1182	REK1022 T1AL 250V	AC110-120V/220-240V 50/60Hz
KUCXJ	ADG7022	AKP7032	DTT1181	REK1077 1.6A/125V	AC120V 50/60Hz





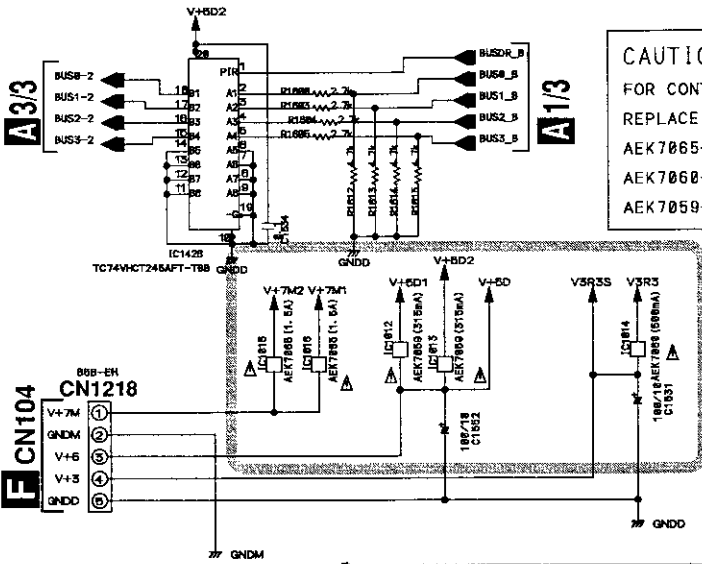

**CAUTION**  
 FOR CONTINUED PROTECTION AGAINST RISK OF FIRE.  
 REPLACE ONLY WITH SAME TYPE NO.  
 AEK7065 -F 49101.5 MFD, BY LITTELFUSE INK. FOR IC1015, IC1016  
 AEK7068 -F 491.500 MFD, BY LITTELFUSE INK. FOR IC1014  
 AEK7059 -F 491.315 MFD, BY LITTELFUSE INK. FOR IC1012, IC1013

: The power supply is shown with the marked box.

THE MARK FOUND ON SOME COMPONENT PARTS INDICATES THE IMPORTANCE OF THE SAFETY FACTOR OF THE PARTS. THEREFORE, WHEN REPLACING, BE SURE TO USE PARTS OF IDENTICAL DESIGNATION.

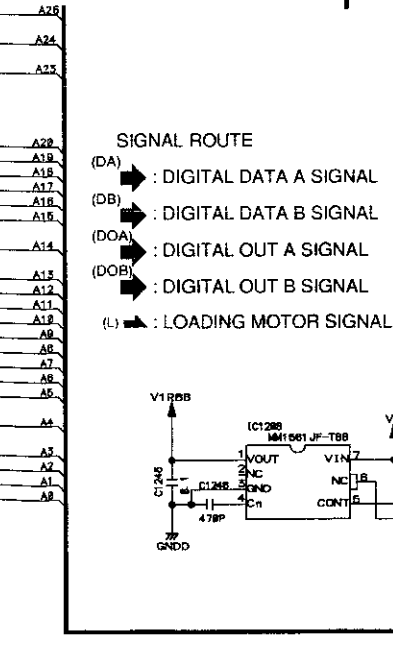
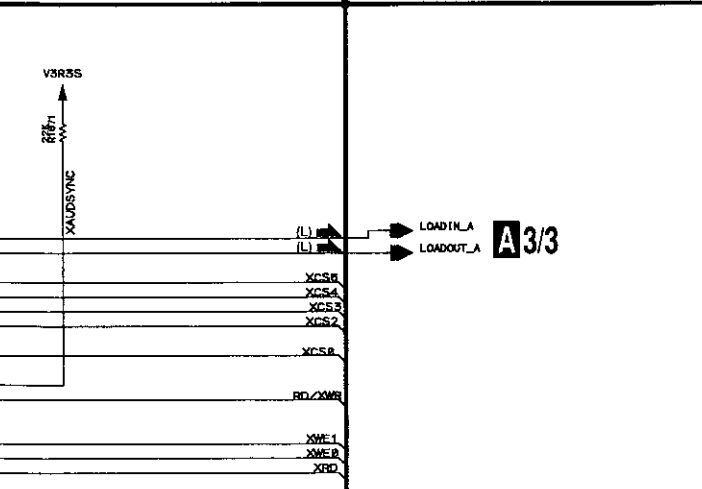

**[NOTES]**  
 RESISTOR  
 NO MARK :RS1/1BS\*#KJ Δ  
 CAPACITOR  
 NO MARK ELECTROLYTIC :CEAT #F  
 NO MARK CERAMIC :CKSR#B #F  
 CH :CCSRCH #F  
 □ IS STANBY

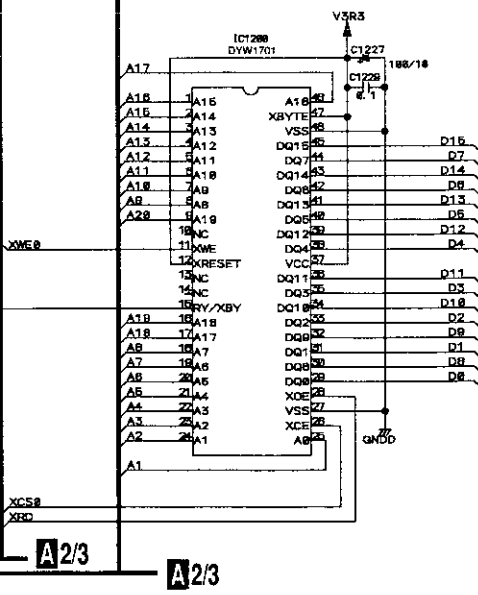
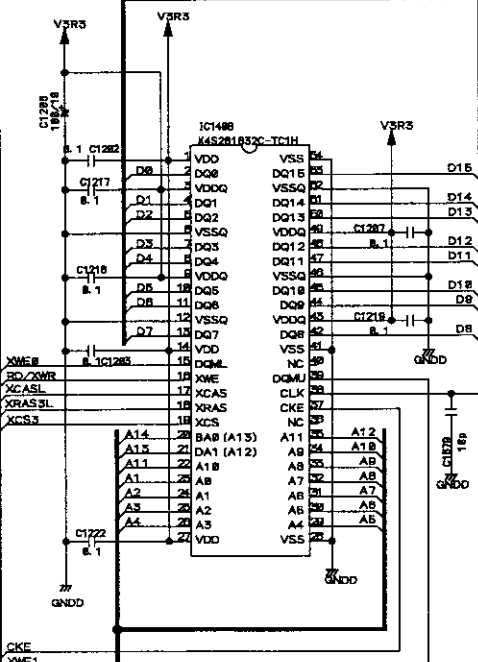
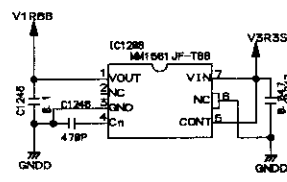

### 3.4 MAIN (2/3) and FRWSW ASSYS

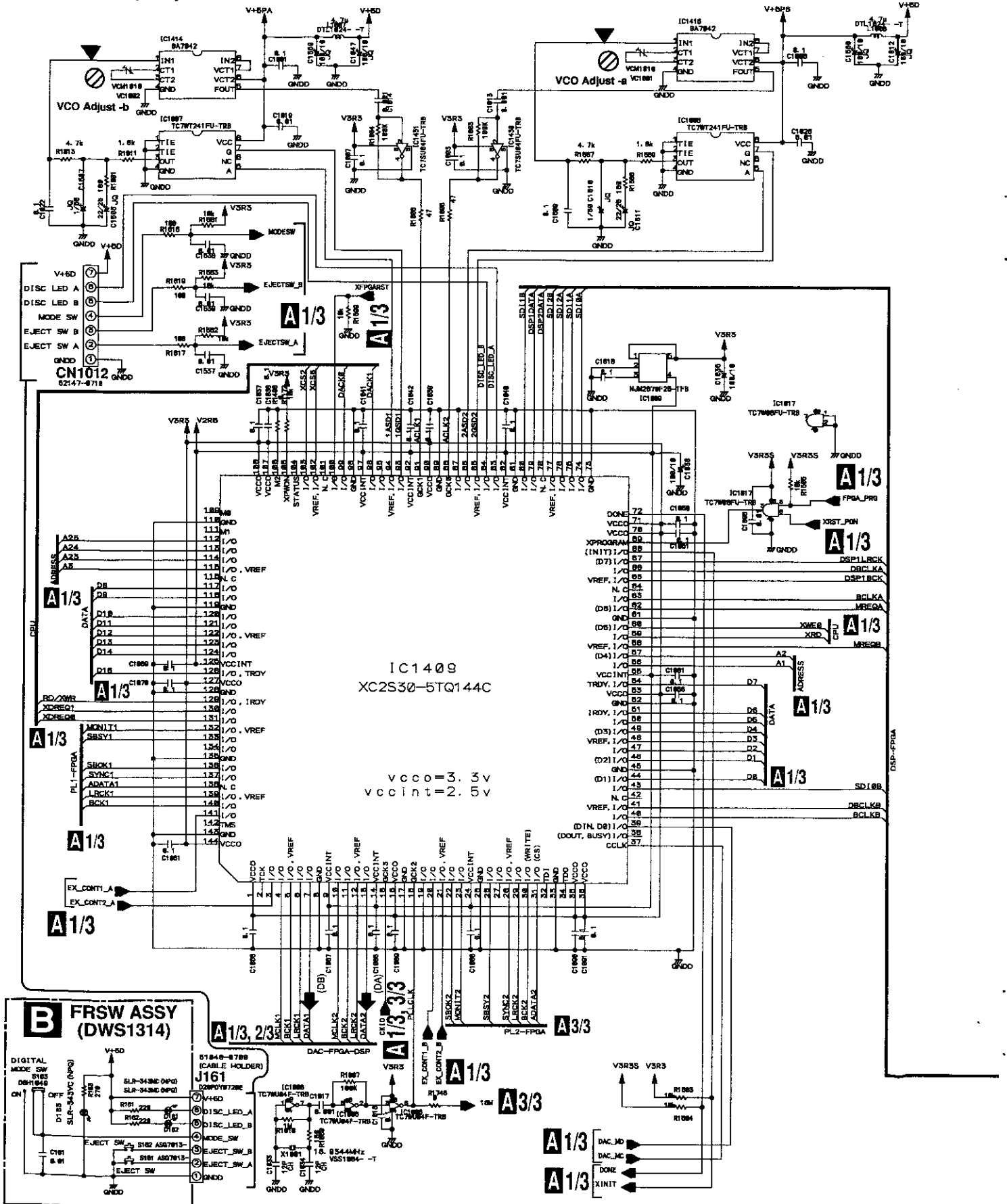



1 2 3 4  
**CMX-3000, CU-V163**

**3.5 MAIN (3/3), SLM1 and SLM2 ASSYS**

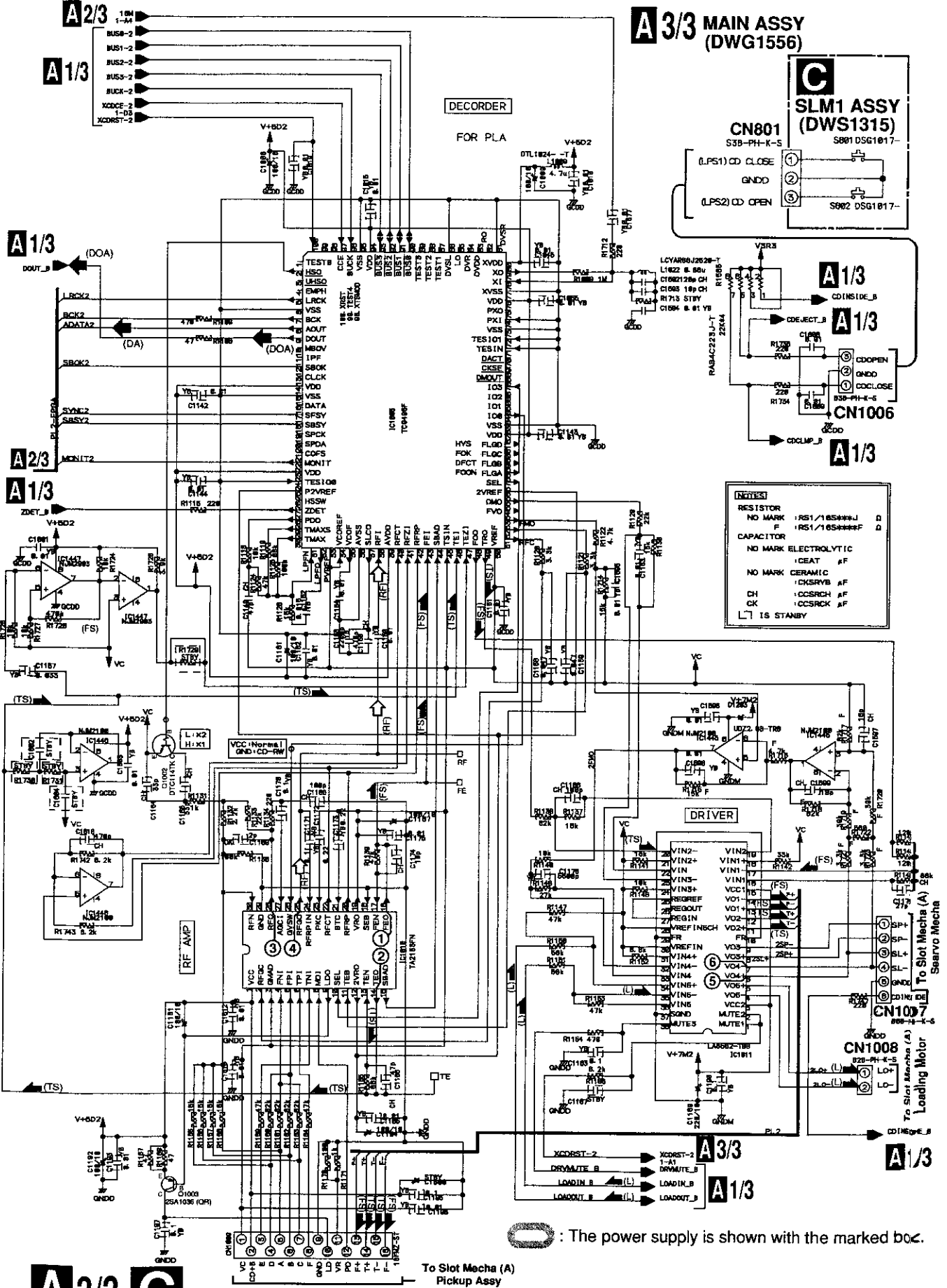

: The power supply is shown with the marked box.

# CMX-3000, CU-V163

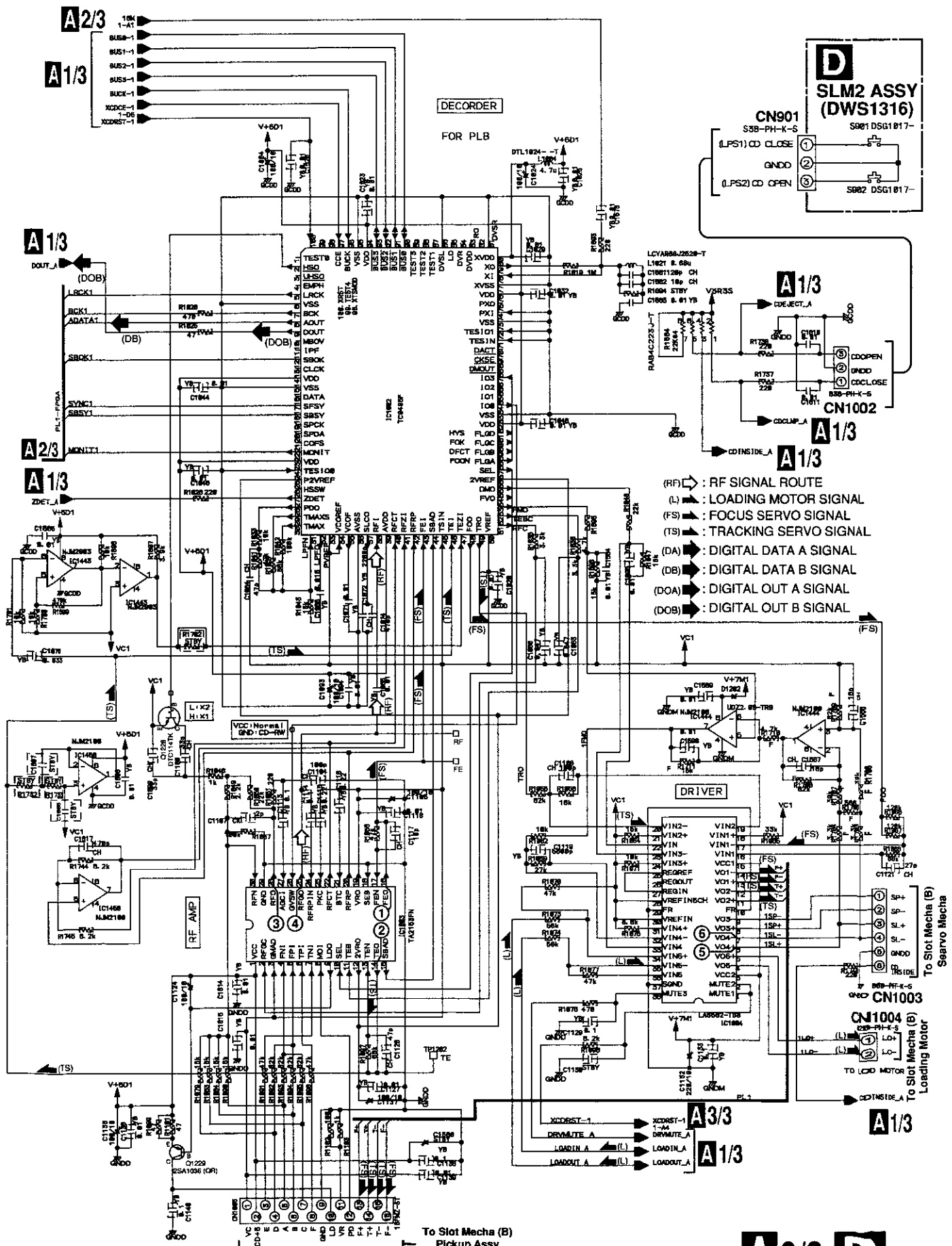

- (RF) : RF SIGNAL ROUTE
- (L) : LOADING MOTOR SIGNAL
- (FS) : FOCUS SERVO SIGNAL
- (TS) : TRACKING SERVO SIGNAL
- (DA) : DIGITAL DATA A SIGNAL
- (DB) : DIGITAL DATA B SIGNAL
- (DOA) : DIGITAL OUT A SIGNAL
- (DOB) : DIGITAL OUT B SIGNAL

**3.6 JACB ASSY**

The power supply is shown with the marked box.

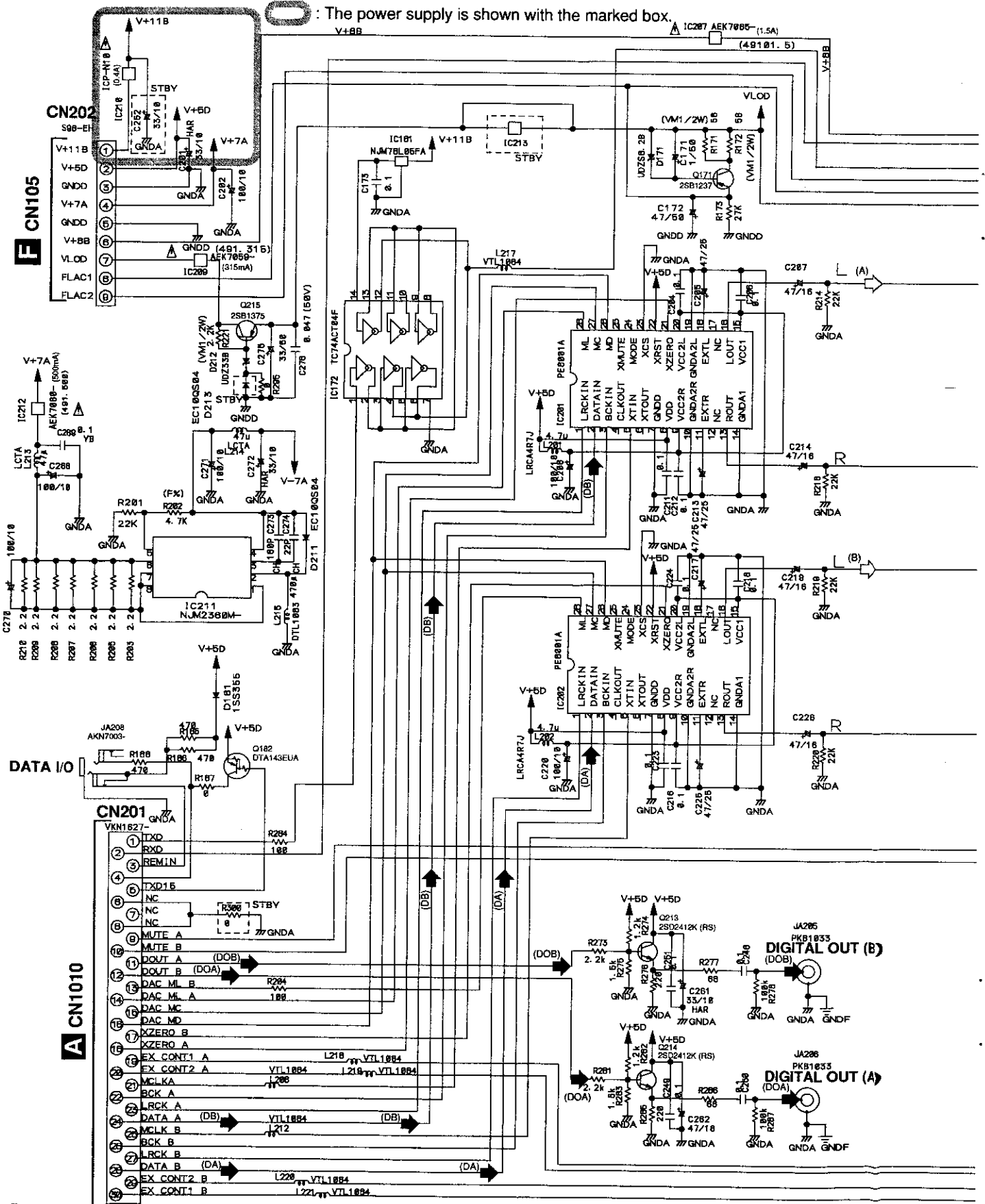

**CAUTION**  
 FOR CONTINUED PROTECTION  
 AGAINST RISK OF FIRE,  
 REPLACE ONLY WITH SAME TYPE NO.  
 ICF-N18 MFD. BY ROHM CO. LTD. FOR IC210  
 AEK7059- 491.315 MFD. BY LITTELFUSE INC. FOR IC209  
 AEK7085- 491.01.5 MFD. BY LITTELFUSE INC. FOR IC207  
 AEK7080- 491.500 MFD. BY LITTELFUSE INC. FOR IC212

**E** JACB ASSY  
 (KUCXJ: DWX2214)  
 (WYXJ: RLBXJ: DWX2200)

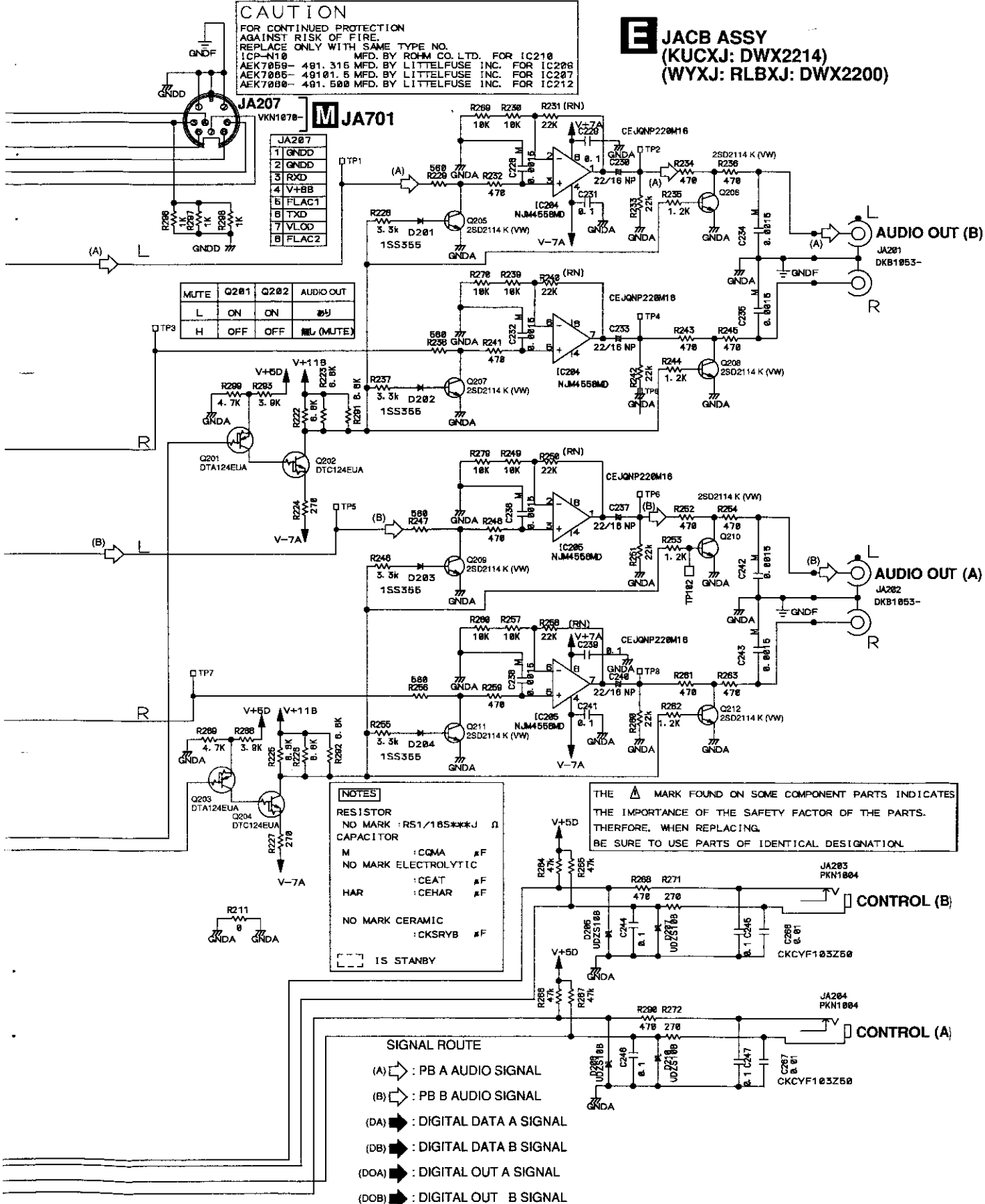

**JA207**  
 VKN1878-

1	GNDD
2	GNDD
3	RXD
4	V+5B
5	FLAC1
6	TXD
7	VLOD
8	FLAC2

**JA701**

**NOTES**  
 RESISTOR  
 NO MARK : RS1/18S\*\*\*J Ω  
 CAPACITOR  
 M : CQMA #F  
 NO MARK ELECTROLYTIC  
 : CEAT #F  
 HAR : CEHAR #F  
 NO MARK CERAMIC  
 : CKSRYB #F  
 [ ] IS STANBY

THE **Δ** MARK FOUND ON SOME COMPONENT PARTS INDICATES THE IMPORTANCE OF THE SAFETY FACTOR OF THE PARTS. THEREFORE, WHEN REPLACING, BE SURE TO USE PARTS OF IDENTICAL DESIGNATION.

- SIGNAL ROUTE**
- (A) → : PB A AUDIO SIGNAL
  - (B) → : PB B AUDIO SIGNAL
  - (DA) → : DIGITAL DATA A SIGNAL
  - (DB) → : DIGITAL DATA B SIGNAL
  - (DOA) → : DIGITAL OUT A SIGNAL
  - (DOB) → : DIGITAL OUT B SIGNAL

**3.7 PWRB, REGB and ACIN ASSYS**

THE **▲** MARK FOUND ON SOME COMPONENT PARTS INDICATES THE IMPORTANCE OF THE SAFETY FACTOR OF THE PARTS. THEREFORE, WHEN REPLACING, BE SURE TO USE PARTS OF IDENTICAL DESIGNATION.

**F**  
**PWRB ASSY**  
**(KUCXJ: DWR1345)**  
**(WYXJ: DWR1345)**  
**(RLBXJ: DWR1348)**

**KUCXJ type**

**G** **ACIN ASSY**  
**(DWR1349)**

**CAUTION**  
 FOR CONTINUED PROTECTION AGAINST RISK OF FIRE, REPLACE WITH SAME TYPE AND RATINGS ONLY

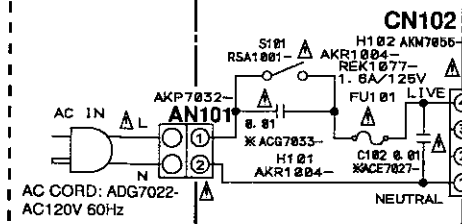

**F** **PWRB ASSY**  
**(DWR1345)**

- D1 03 1SR154-400
- D1 04 1SR154-400
- D1 05 1SR154-400
- D1 06 1SR154-400

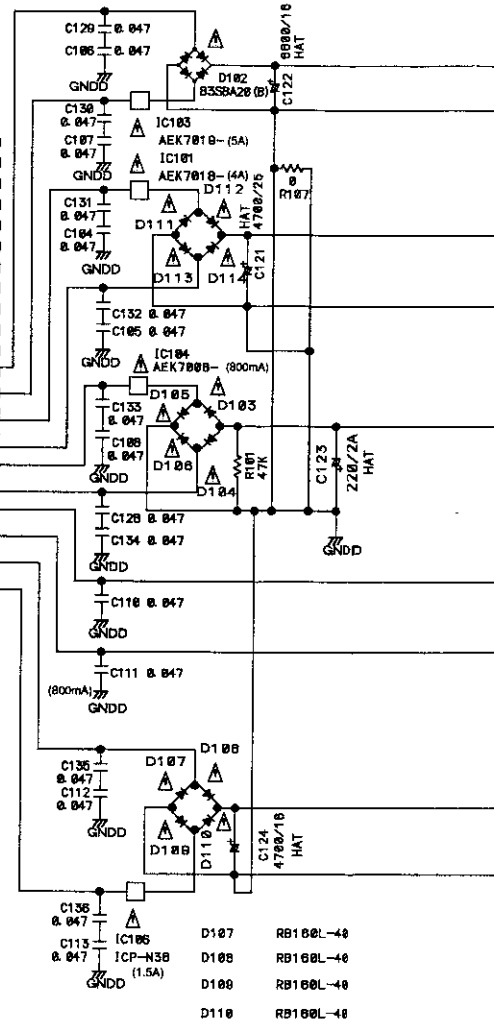
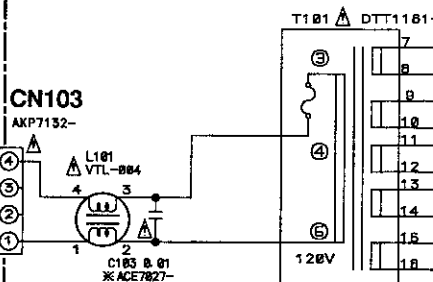

**RLBXJ type**

**G** **ACIN ASSY**  
**(DWR1346)**

**CAUTION**  
 FOR CONTINUED PROTECTION AGAINST RISK OF FIRE, REPLACE WITH SAME TYPE AND RATINGS ONLY

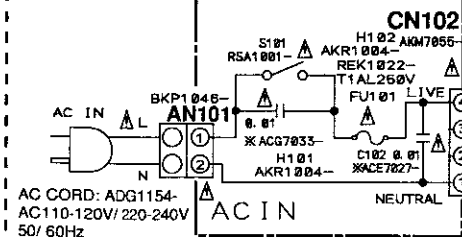

**F** **PWRB ASSY**  
**(DWR1348)**

- D1 05 1SR154-400
- D1 06 1SR154-400

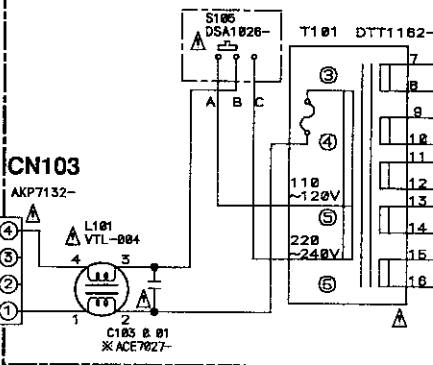

**CAUTION**  
 FOR CONTINUED PROTECTION AGAINST RISK OF FIRE, REPLACE ONLY WITH SAME TYPE NO.

- AEK7019- 491025
- MFD. BY LITTELFUSE INC. FOR IC103
- AEK7018- 491004
- MFD. BY LITTELFUSE INC. FOR IC101
- AEK7028- 491.800
- MFD. BY LITTELFUSE INC. FOR IC104
- ICP-N38
- MFD. BY ROHM CO. LTD. FOR IC106
- AEK7011- 49101.5
- MFD. BY LITTELFUSE INC. FOR IC107
- AEK7050- 491.315
- MFD. BY LITTELFUSE INC. FOR IC108

**WYXJ type**

**G** **ACIN ASSY**  
**(DWR1346)**

**CAUTION**  
 FOR CONTINUED PROTECTION AGAINST RISK OF FIRE, REPLACE WITH SAME TYPE AND RATINGS ONLY

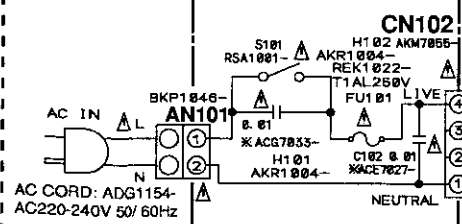

**F** **PWRB ASSY**  
**(DWR1345)**

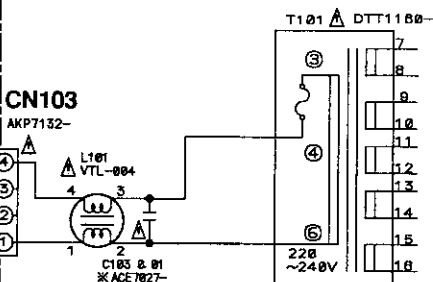



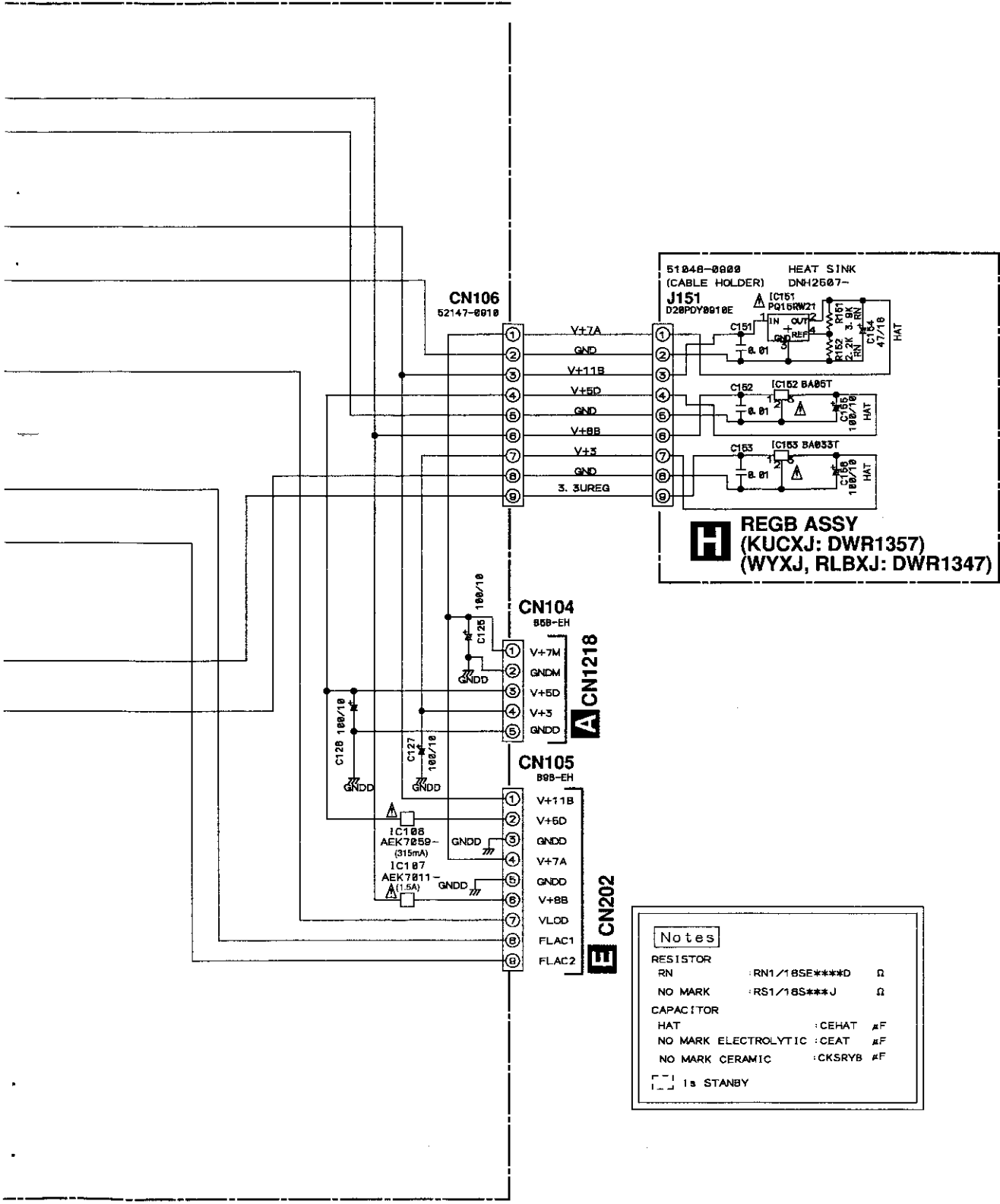

51048-0000 HEAT SINK  
(CABLE HOLDER) DNH2607-

J151  
D28PDY8910E

IC151 PQ16RW21

IC152 BA805T

IC153 BA8053T

REG B ASSY  
(KUCXJ: DWR1357)  
(WYXJ, RLBXJ: DWR1347)

Notes

RESISTOR		
RN	:RN1/18SE****D	Ω
NO MARK	:RS1/18S***J	Ω
CAPACITOR		
HAT	:CEHAT	μF
NO MARK ELECTROLYTIC	:CEAT	μF
NO MARK CERAMIC	:CK5RYB	μF

□ is STANBY



3.8 CNTA and PHTA ASSYS

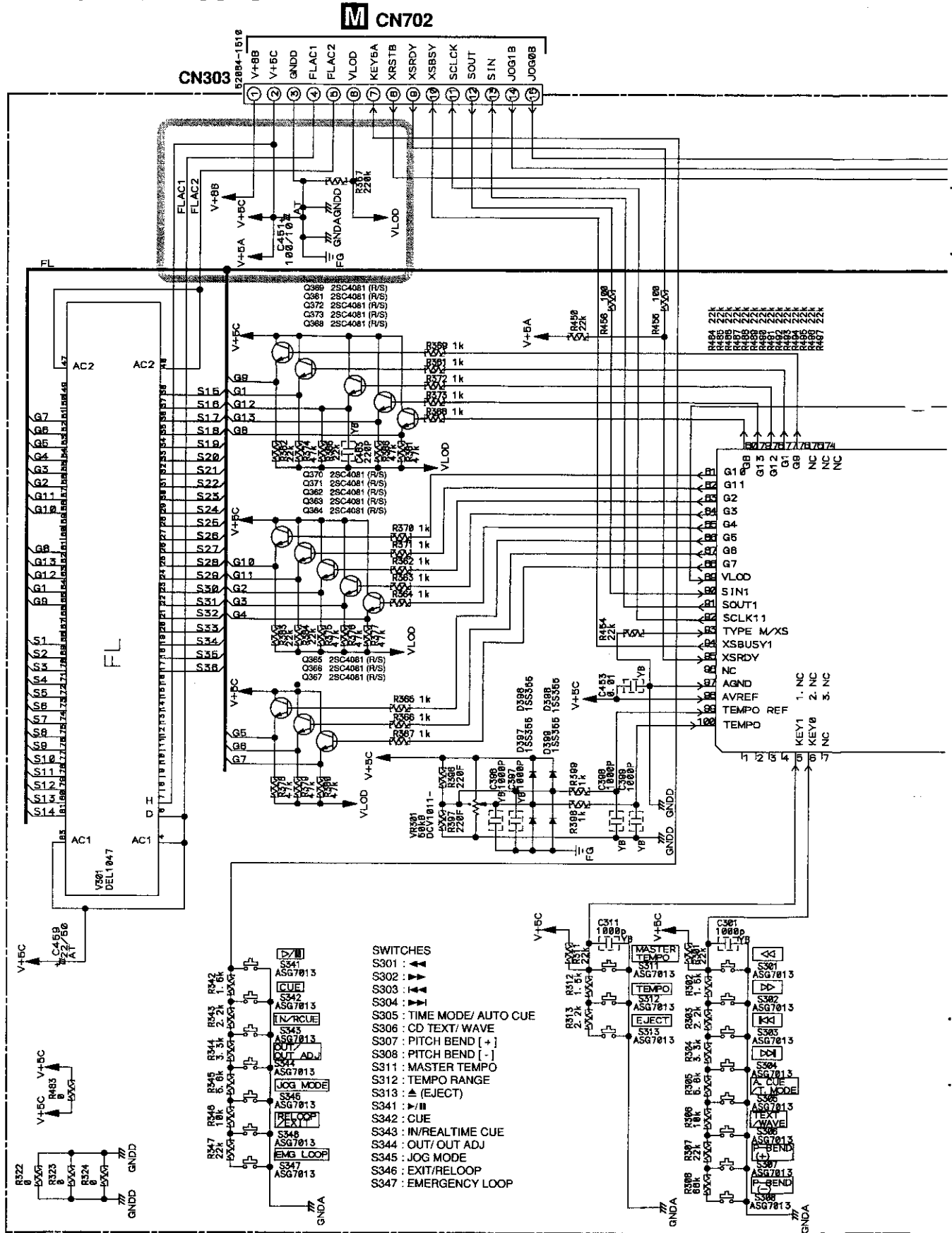

 : The power supply is shown with the marked box.

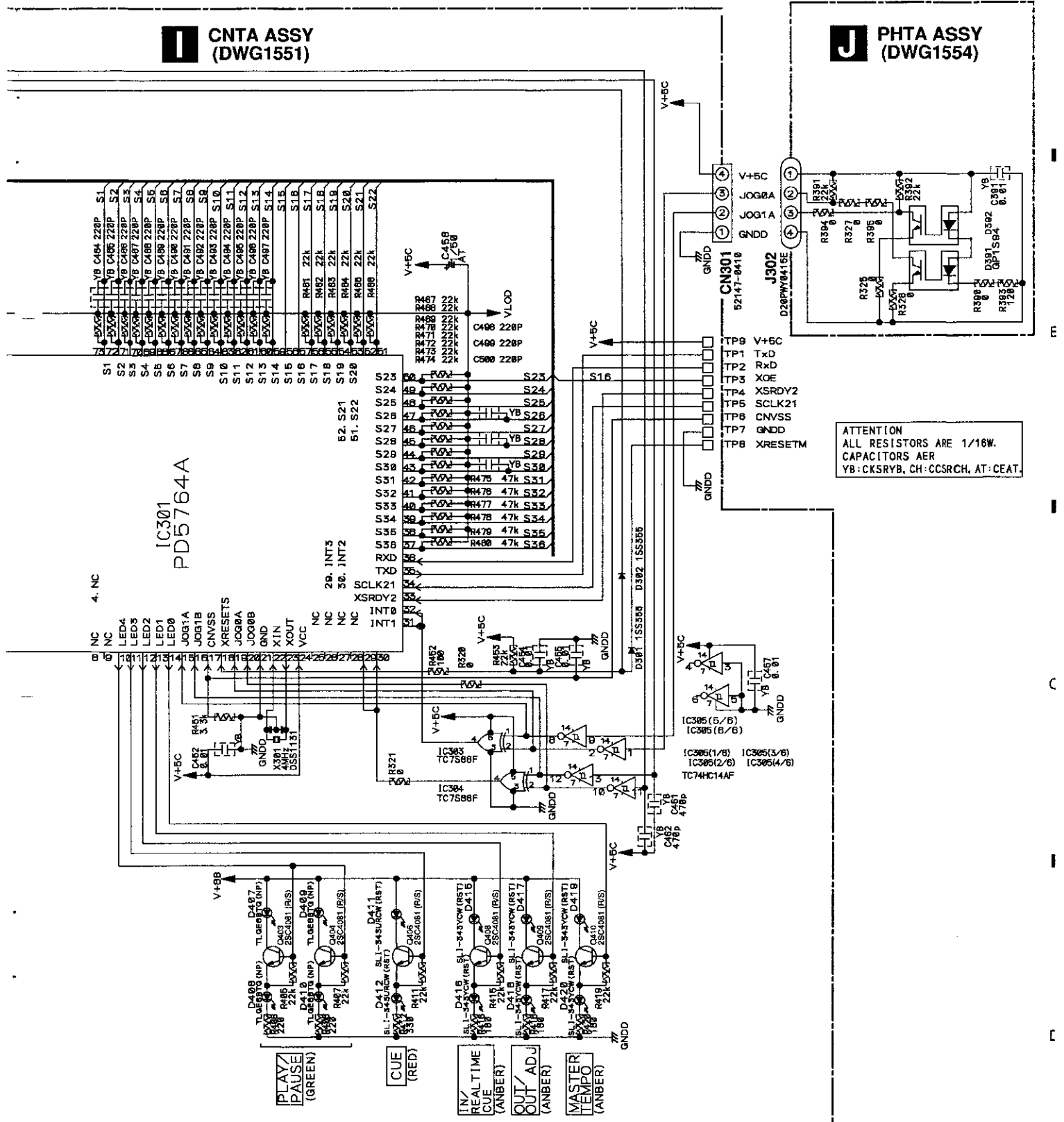

**3.9 CNTB and PHTB ASSYS**

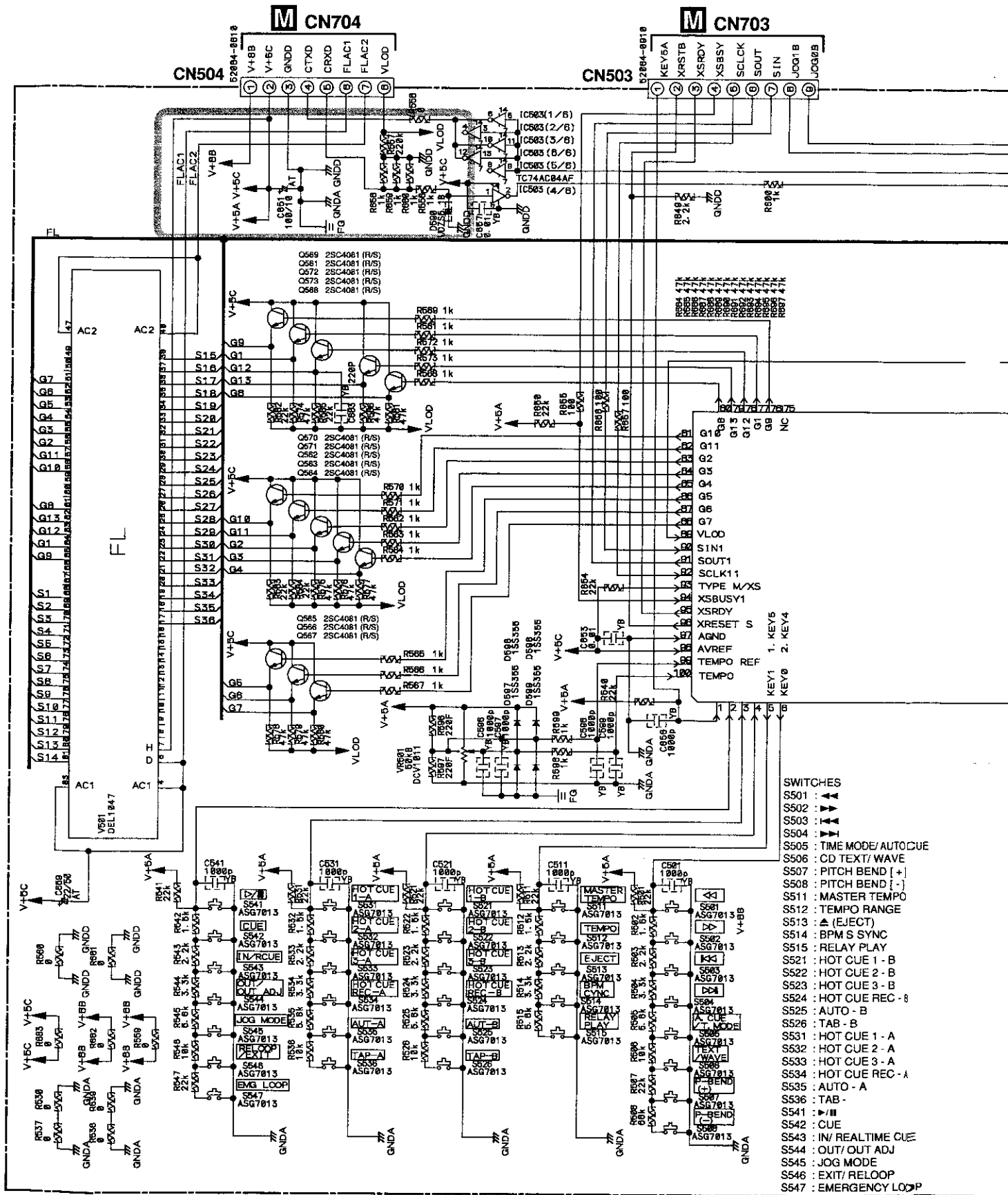

 : The power supply is shown with the marked box.

**K** CNTB ASSY (DWG1552)

**L** PHTB ASSY (DWG1555)

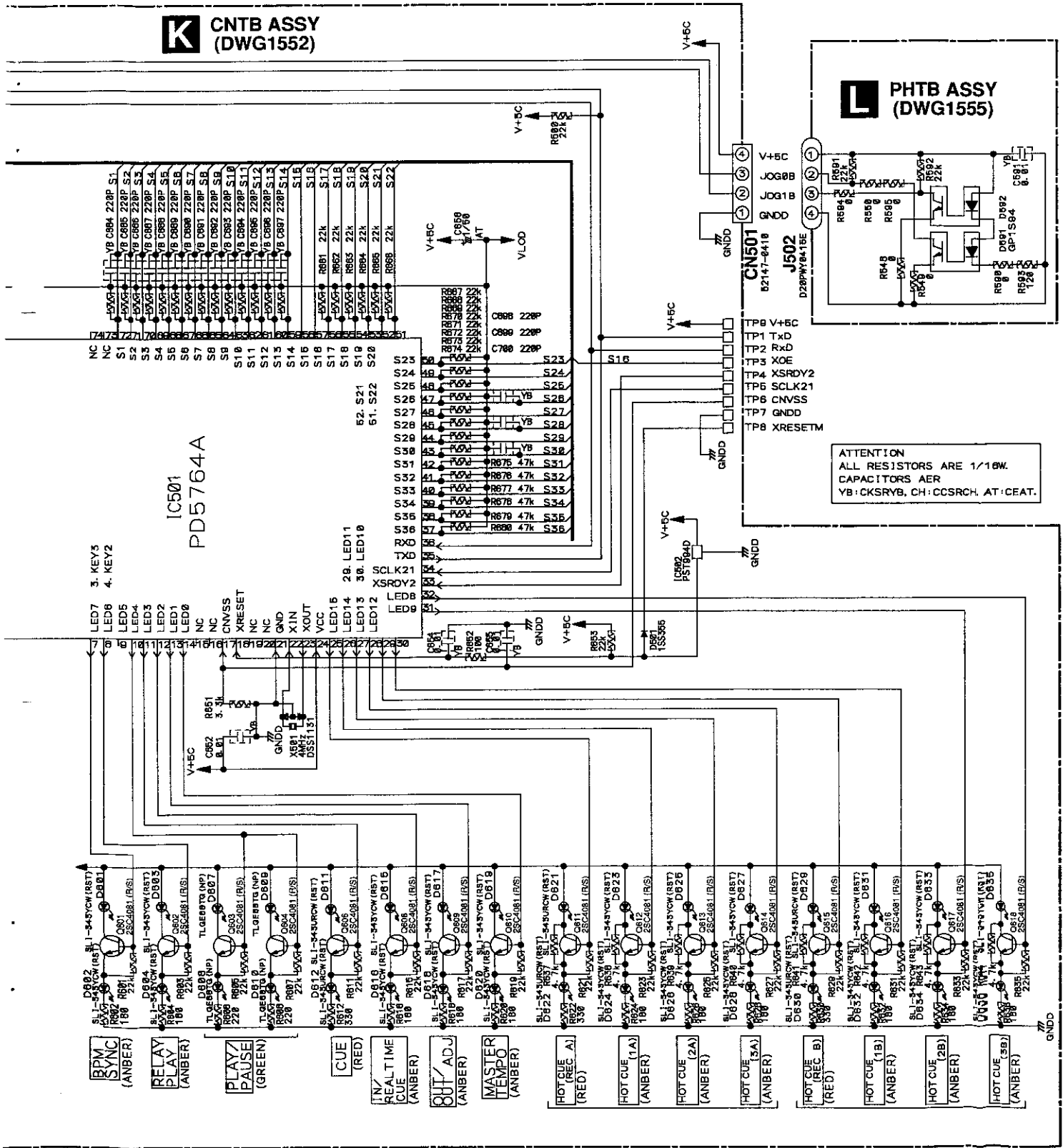

**3.10 CNNB ASSY**

 : The power supply is shown with the marked box.

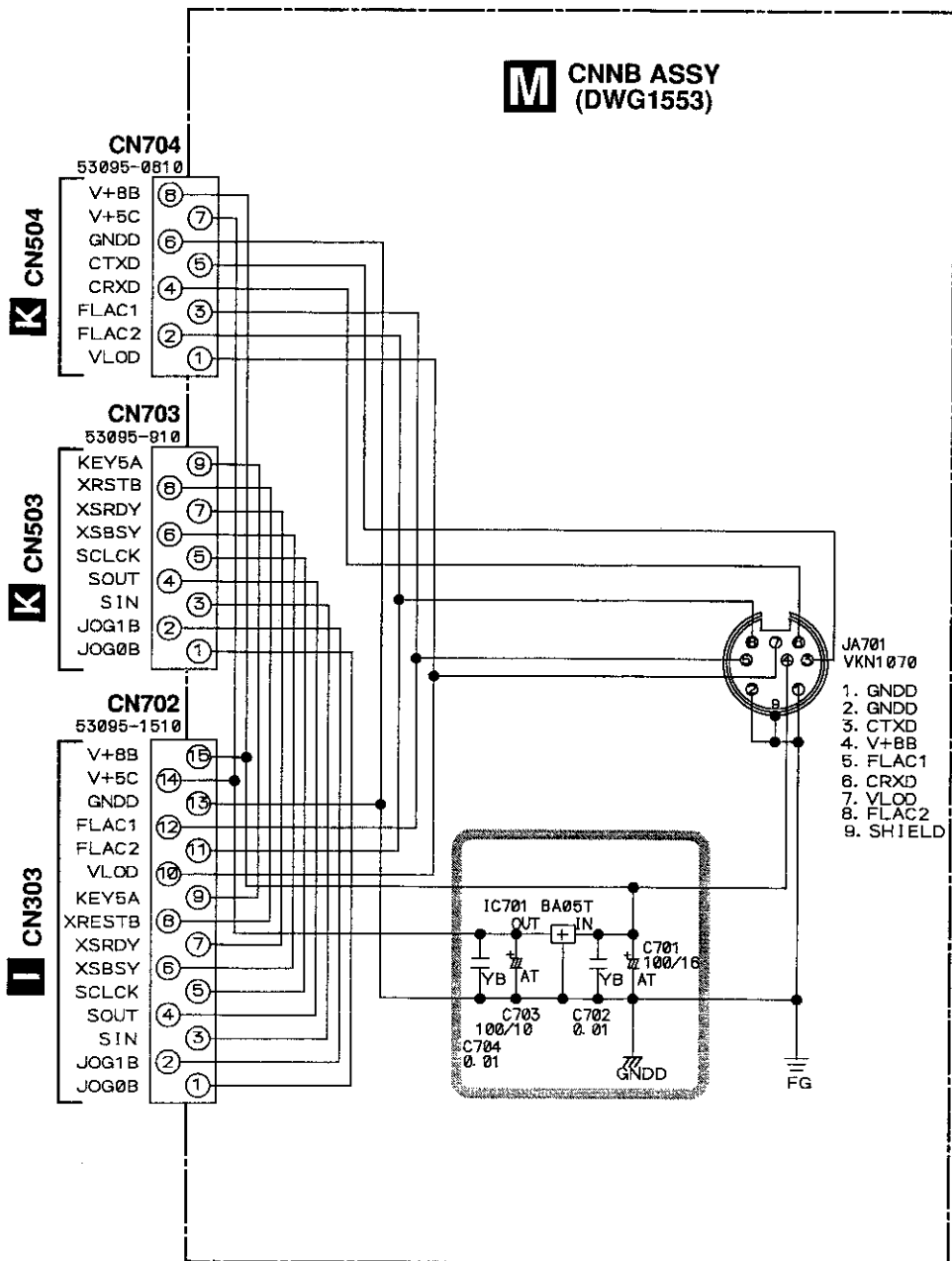

**ATTENTION**  
 CAPACITORS ARE  
 YB : CKSRYB, AT : CEAT.

■ Waveforms

A 3/3 MAIN ASSY

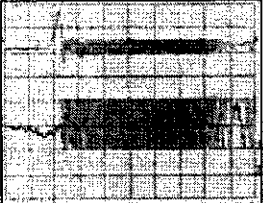
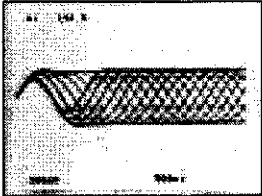
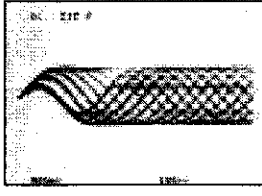
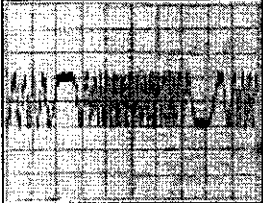
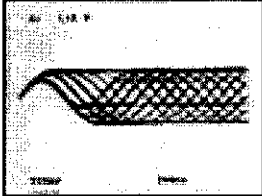
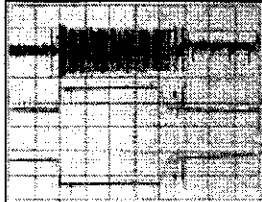
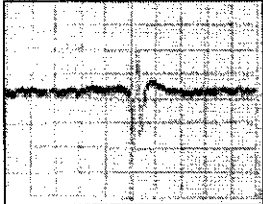
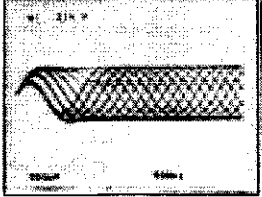
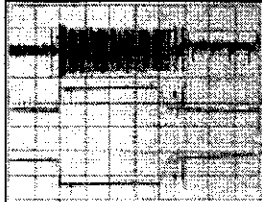
<p>Mode: Focus IN  <b>① IC1010- 16pin (FE)</b>  <b>IC1003- 16pin (FE)</b>            V: 0.5V/div. H: 5mS/div.</p> <p><b>② IC1010- 14pin (TE)</b>  <b>IC1003- 14pin (TE)</b>            V: 1V/div. H: 5mS/div.</p> 	<p>Mode: RF (Play Mode x1)  <b>③ IC1010- 28pin (RFO)</b>  <b>IC1003- 28pin (RFO)</b>            V: 500mV/div. H: 500nS/div.</p> 	<p>Mode: AGC RF (PLAY MODE x2)  <b>④ IC1010- 25pin (RFGO)</b>  <b>IC1003- 25pin (RFGO)</b>            V: 500mV/div. H: 200nS/div.</p> 
<p>Mode: Tracking Open  <b>② IC1010- 14pin (TE)</b>  <b>IC1003- 14pin (TE)</b>            V: 1V/div. H: 2mS/div.</p> 	<p>Mode: RF (Play Mode x2)  <b>③ IC1010- 28pin (RFO)</b>  <b>IC1003- 28pin (RFO)</b>            V: 500mV/div. H: 200nS/div.</p> 	<p>Mode: 1 Track → 16 Track Serch  <b>② IC1010- 14pin (TE)</b>  <b>IC1003- 14pin (TE)</b>            V: 1V/div. H: 0.2S/div.</p> <p><b>⑤ IC1011- 6pin (SL+)</b>  <b>IC1004- 6pin (SL+)</b>            V: 2V/div. H: 0.2S/div.</p> <p><b>⑥ IC1011- 7pin (SL-)</b>  <b>IC1004- 7pin (SL-)</b>            V: 2V/div. H: 0.2S/div.</p> 
<p>Mode: 1 Track Jump  <b>② IC1010- 14pin (TE)</b>  <b>IC1003- 14pin (TE)</b>            V: 0.5V/div. H: 2mS/div.</p> 	<p>Mode: AGC RF (Play Mode x1)  <b>④ IC1010- 25pin (RFGO)</b>  <b>IC1003- 25pin (RFGO)</b>            V: 500mV/div. H: 500nS/div.</p> 	

# CMX-3000, CU-V163

## ■ Voltage (1/3)

### A 1/3 MAIN ASSY

IC1200 (DYW1701)	
Pin No.	Voltage (V)
1	0 to 3.2
2	0 to 3.2
3	0 to 3.2
4	0 to 3.2
5	0 to 3.2
6	0 to 3.2
7	0 to 3.2
8	0 to 3.2
9	0 to 3.2
10	0.7
11	0.7
12	0 to 3.2
13	0.7
14	0.7
15	3.1
16	0 to 3.2
17	0 to 3.2
18	0 to 3.2
19	0 to 3.2
20	0 to 3.2
21	0 to 3.2
22	0 to 3.2
23	0 to 3.2
24	0 to 3.2
25	0 to 3.2
26	3.2
27	0
28	0 to 3.2
29	0 to 3.2
30	0 to 3.2
31	0 to 3.2
32	0 to 3.2
33	0 to 3.2
34	0 to 3.2
35	0 to 3.2
36	0 to 3.2
37	3.1
38	0 to 3.2
39	0 to 3.2
40	0 to 3.2
41	0 to 3.2
42	0 to 3.2
43	0 to 3.2
44	0 to 3.2
45	0 to 3.2
46	0
47	3.1
48	0 to 3.2

IC1022 (M51957BFP)	
Pin No.	Voltage (V)
1	0
2	0
3	0
4	0
5	1.3
6	3.2
7	3.2
8	0

IC1204 (HD6417709AF100B)			
Pin No.	Voltage (V)	Pin No.	Voltage (V)
1	3.2	91	3.2
2	0	92	3.2
3	1.8	93	0 to 3.3
4	1.6	94	3.2
5	0	95	0
6	0	96	3.3
7	0	97	3.3
8	0	98	0 to 3.3
9	0	99	0 to 3.3
10	3.3	100	0 to 3.3
11	3.2	101	3.2
12	3.3	102	3.2
13	0 to 3.3	103	3.2
14	0	104	3.2
15	0	105	3.2
16	0	106	0 to 3.3
17	3.3	107	0 to 3.3
18	3.3	108	0 to 3.3
19	0	109	0
20	0	110	0
21	3.3	111	3.2
22	0	112	0
23	0	113	0
24	0	114	0 to 3.3
25	0	115	0 to 3.3
26	0	116	3.2
27	0	117	3.2
28	0	118	0
29	1.8	119	0
30	0	120	3.3
31	0	121	3.2
32	0	122	3.2
33	0	123	3.2
34	0 to 3.3	124	3.2
35	3.2	125	3.2
36	0 to 3.3	126	3.1
37	0 to 3.3	127	3
38	0 to 3.3	128	3.2
39	0 to 3.3	129	2.8
40	0 to 3.3	130	0
41	0 to 3.3	131	0
42	0 to 3.3	132	0
43	0 to 3.3	133	3.2
44	0 to 3.3	134	1.8
45	0	135	3.2
46	0 to 3.3	136	3.0
47	3.3	137	3.0
48	0 to 3.3	138	3.0
49	0 to 3.3	139	3.0
50	0 to 3.3	140	3.1
51	0 to 3.3	141	0
52	0 to 3.3	142	3.0
53	0 to 3.3	143	0
54	0 to 3.3	144	0
55	0 to 3.3	145	1.8
56	0 to 3.3	146	0.7
57	0	147	0
58	0 to 3.3	148	0
59	3.3	149	0.7
60	0 to 3.3	150	1.8
61	0 to 3.3	151	1.9
62	0 to 3.3	152	0
63	0 to 3.3	153	0
64	0 to 3.3	154	1.8
65	0 to 3.3	155	1.6
66	0 to 3.3	156	1.1
67	0 to 3.3	157	3.2
68	0 to 3.3	158	3.2
69	0	159	3.2
70	0 to 3.3	160	0 to 3.2
71	3.3	161	0
72	0 to 3.3	162	0 to 3.2
73	0 to 3.3	163	3.2
74	0 to 3.3	164	0
75	0 to 3.3	165	3.2
76	0 to 3.3	166	3.2
77	0 to 3.3	167	0 to 3.2
78	0 to 3.3	168	0 to 3.2
79	0	169	0
80	0	170	0
81	1.8	171	3.2
82	0 to 3.3	172	3.2
83	0	173	0
84	0 to 3.3	174	0 to 3.2
85	3.3	175	1.8
86	0 to 3.3	176	3.0
87	3.2	177	0 to 3.2
88	0 to 3.3	178	0 to 3.2
89	0 to 3.3	179	0 to 3.2
90	0 to 3.3	180	0 to 3.2

IC1408 (K4S281632)	
Pin No.	Voltage (V)
1	3.2
2	0 to 3.3
3	3.2
4	0 to 3.3
5	0 to 3.3
6	0
7	0 to 3.3
8	0 to 3.3
9	3.2
10	0 to 3.3
11	0 to 3.3
12	0
13	0 to 3.3
14	3.2
15	0 to 3.3
16	0 to 3.3
17	0 to 3.3
18	0 to 3.3
19	0 to 3.3
20	0 to 3.3
21	0 to 3.3
22	0 to 3.3
23	0 to 3.3
24	0 to 3.3
25	0 to 3.3
26	0 to 3.3
27	3.2
28	0
29	0 to 3.3
30	0 to 3.3
31	0 to 3.3
32	0 to 3.3
33	0 to 3.3
34	0 to 3.3
35	0 to 3.3
36	0
37	3.2
38	0 to 3.3
39	0 to 3.3
40	0.7
41	0
42	0 to 3.3
43	3.2
44	0 to 3.3
45	0 to 3.3
46	0
47	0 to 3.3
48	0 to 3.3
49	3.2
50	0.7
51	0 to 3.3
52	0
53	0 to 3.3
54	0



■ Voltage (2/3)

A 2/3 MAIN ASSY

IC1402 (XCA56367PV150)

Pin No.	Voltage (V)	Pin No.	Voltage (V)
1	1.1	91	1.8
2	0.7	92	0
3	0.6	93	0
4	0 to 3.2	94	0
5	0 to 3.2	95	3.2
6	0 to 3.2	96	0
7	0 to 3.2	97	0
8	3.2	98	0
9	0	99	0
10	0 to 3.2	100	0
11	0 to 3.2	101	0
12	0 to 3.2	102	0
13	0 to 3.2	103	3.2
14	0	104	0
15	0 to 3.2	105	0
16	0 to 3.2	106	0
17	0 to 3.2	107	0
18	1.8	108	0
19	0	109	0
20	3.3	110	0
21	0 to 3.2	111	3.2
22	0 to 3.2	112	0
23	0 to 3.2	113	0
24	0	114	0.6
25	3.2	115	0.6
26	0	116	0
27	0	117	0
28	0.7	118	0.6
29	0	119	0.7
30	3.2	120	0.7
31	3.2	121	0
32	0.8	122	0
33	0 to 3.2	123	0
34	0 to 3.2	124	0
35	0 to 3.2	125	0
36	0 to 3.2	126	0
37	0 to 3.2	127	0
38	3.2	128	0
39	0	129	3.2
40	0 to 3.2	130	0
41	0 to 3.2	131	0
42	0 to 3.2	132	0
43	0 to 3.2	133	0
44	3.2	134	2.6
45	1.8	135	0
46	0.9	136	0
47	0	137	0
48	0 to 3.2	138	1 to 3.2
49	3.2	139	0
50	0 to 3.2	140	0
51	0.9	141	0
52	0.7	142	0
53	3.2	143	0
54	0 to 3.2	144	0.6
55	0		
56	0 to 3.4		
57	1.8		
58	0		
59	0 to 3.2		
60	0 to 3.2		
61	0.7		
62	0		
63	3.2		
64	3.1		
65	3.2		
66	0		
67	0.7		
68	0.7		
69	0.7		
70	0.7		
71	0		
72	0.7		
73	0		
74	3.2		
75	0		
76	0		
77	0		
78	0		
79	0		
80	3.2		
81	0		
82	0		
83	0		
84	0		
85	0		
86	3.2		
87	0		
88	0		
89	0		
90	0		

IC1409 (XC2S30-5TQ144C)

Pin No.	Voltage (V)	Pin No.	Voltage (V)
1	3.2	91	0
2	2.4	92	2.5
3	3.1	93	0
4	0.4 to 2.1	94	3.2
5	0 to 3.1	95	0
6	0 to 3.1	96	0 to 3.2
7	0 to 3.1	97	2.5
8	0	98	0
9	0	99	0 to 3.2
10	0.4 to 2.9	100	3.2
11	0 to 3.1	101	0
12	0 to 3.1	102	3.2
13	0 to 3.1	103	0 to 3.2
14	2.5	104	0.6
15	0 to 3.1	105	0.6
16	0.7	106	0
17	0.6	107	3.2
18	0.6	108	3.2
19	0.6	109	2.5
20	0.6	110	0
21	3.2	111	2.5
22	0.6	112	0 to 3.2
23	0 to 4.9	113	0 to 3.2
24	2.5	114	0 to 3.2
25	0.6	115	0 to 3.2
26	0.6	116	0
27	0	117	0 to 3.2
28	0 to 4.9	118	0 to 3.2
29	0 to 4.9	119	0
30	1 to 3.8	120	0 to 3.2
31	0 to 4.9	121	0 to 3.2
32	2.4	122	0 to 3.2
33	0.6	123	0 to 3.2
34	0.6	124	0 to 3.2
35	3.2	125	0.6
36	0.6	126	3.2
37	3.2	127	0
38	0	128	0.7
39	0	129	0.7
40	0 to 3.0	130	0 to 3.2
41	0 to 3.2	131	0 to 3.2
42	0	132	0 to 4.9
43	0 to 3.2	133	0.7
44	0 to 3.2	134	0
45	0	135	0
46	0 to 3.2	136	0 to 4.9
47	0 to 3.2	137	0 to 4.9
48	0 to 3.2	138	0 to 4.9
49	0 to 3.2	139	0 to 4.9
50	0 to 3.2	140	1 to 3.8
51	0 to 3.2	141	3.2
52	0	142	2.4
53	3.2	143	0
54	0 to 3.2	144	3.2
55	2.5		
56	0 to 3.2		
57	0 to 3.2		
58	0 to 3.2		
59	0 to 3.2		
60	0 to 3.2		
61	0		
62	0		
63	0 to 3.0		
64	0		
65	0 to 3.0		
66	0 to 3.1		
67	2.9		
68	2.9		
69	3.2		
70	3.2		
71	3.2		
72	3.2		
73	0		
74	0 to 3.1		
75	0 to 3.1		
76	0 to 3.1		
77	0.6		
78	0 to 3.1		
79	0 to 3.1		
80	0 to 3.1		
81	0		
82	2.5		
83	0.6		
84	0		
85	0		
86	3.2		
87	0		
88	0.7 to 2.6		
89	0		
90	0.6		

IC1414 (BA7042)

Pin No.	Voltage (V)
1	0
2	2.3
3	0
4	0
5	2.5 to 4.5
6	5.0
7	2.6
8	2.6

# CMX-3000, CU-V163

## ■ Voltage (3/3)

### A 3/3 MAIN ASSY

IC1005 (TC9495F)			
Pin No.	Voltage (V)	Pin No.	Voltage (V)
1	4.4	91	0 to 5.0
2	0	92	0 to 5.0
3	5.0	93	0 to 5.0
4	0	94	5.0
5	0 to 4.9	95	0
6	0	96	5.0
7	0.3 to 4.4	97	0 to 5.0
8	0 to 4.9	98	4.7
9	0	99	4.7
10	0	100	5.0
11	0		
12	5.0		
13	0 to 4.2		
14	5.0		
15	0		
16	0 to 4.9		
17	0 to 4.9		
18	0 to 4.9		
19	0.3 to 4.2		
20	0 to 4.7		
21	0 to 4.9		
22	0 to 4.5		
23	4.9		
24	0		
25	4.2		
26	2.1		
27	0 to 4.9		
28	5.0		
29	0		
30	4.2		
31	2.1		
32	2.0		
33	2.1		
34	2.1		
35	1.3		
36	0		
37	2.1		
38	1.6 to 2.6		
39	5.0		
40	3.0		
41	3.1		
42	2.5 to 2.9		
43	2.5 to 2.9		
44	2.5		
45	2.1		
46	1.4 to 2.9		
47	0 to 4.1		
48	0.7 to 2.2		
49	1.4 to 3.4		
50	2.1		
51	0.4 to 2.1		
52	2.1		
53	0.4 to 2.1		
54	2.1		
55	0 to 4.2		
56	4.2		
57	2.1		
58	0 to 5.0		
59	5.0		
60	5.0		
61	0		
62	5.0		
63	0		
64	5.0		
65	0		
66	0		
67	0 to 5.0		
68	4.9		
69	4.9		
70	4.9		
71	0		
72	0		
73	0		
74	0		
75	5.0		
76	5.0		
77	0		
78	1.0 to 3.0		
79	0.5 to 4.5		
80	5.0		
81	0		
82	0.4		
83	0		
84	0		
85	0.4		
86	0		
87	4.8		
88	4.8		
89	4.8		
90	0 to 5.0		

### IC1010 (TA2153FN)

Pin No.	Voltage (V)
1	4.9
2	1.8
3	2.1
4	2.1
5	2.1
6	2.0
7	2.1
8	0
9	4.3
10	0
11	2.1
12	4.1
13	2.1
14	2.1
15	1.2
16	2.1
17	2.1
18	0.0
19	2.1
20	1.1
21	1.8
22	1.1
23	0.5
24	2.0
25	2.1
26	0
27	2.2
28	1.0 to 2.1
29	0
30	2.1

### IC1011 (LA6562)

Pin No.	Voltage (V)
1	4.3
2	4.3
3	7.3
4	3.3
5	3.3
6	3.4
7	3.2
8	2.5
9	3.5
10	0
11	3.7
12	3.4
13	3.8
14	3.7
15	7.3
16	2.0
17	2.0
18	2.0
19	2.0
20	2.0
21	2.0
22	2.0
23	2.0
24	2.0
25	1.0
26	0.6
27	1.0
28	2.0
29	0
30	2.0
31	2.0
32	2.0
33	2.0
34	2.5
35	2.5
36	2.0
37	0
38	3.2

### E JACB ASSY

IC201 (PE8001)	
Pin No.	Voltage (V)
1	0 to 3.1
2	0 to 3.1
3	0 to 3.1
4	0.3 to 4.4
5	0.5 to 2.7
6	0.8 to 4.8
7	0
8	5.0
9	5.0
10	0
11	0 to 2.5
12	0
13	2.5
14	0
15	5.0
16	2.2
17	0.7
18	0
19	0
20	5.0
21	3.0
22	0
23	0
24	0
25	0 to 4.9
26	0
27	0.5
28	3.2

IC211 (NJM2360M)	
Pin No.	Voltage (V)
1	7.1
2	0 to 5.6
3	-7.5
4	-7.9
5	0.5
6	6.9
7	6.9
8	6.9

### I CNTA ASSY

IC301 (PD5764A)			
Pin No.	Voltage (V)	Pin No.	Voltage (V)
1	0	51	-31 to 5.0
2	0	52	-31 to 5.0
3	0	53	-31 to 5.0
4	0	54	-31 to 5.0
5	5.0	55	-31 to 5.0
6	5.0	56	-31 to 5.0
7	0	57	-31 to 5.0
8	0	58	-31 to 5.0
9	0	59	-31 to 5.0
10	0 to 5.0	60	-31 to 5.0
11	0 to 5.0	61	-31 to 5.0
12	0 to 5.0	62	-31 to 5.0
13	0 to 5.0	63	-31 to 5.0
14	0 to 5.0	64	-31 to 5.0
15	0 to 5.0	65	-31 to 5.0
16	0 to 5.0	66	-31 to 5.0
17	0	67	-31 to 5.0
18	5.0	68	-31 to 5.0
19	0 to 5.0	69	-31 to 5.0
20	0 to 5.0	70	-31 to 5.0
21	0	71	-31 to 5.0
22	0 to 4.3	72	-31 to 5.0
23	0 to 5.0	73	-31
24	5.0	74	-31
25	0	75	-31
26	0	76	-31 to 5.0
27	0	77	-31 to 5.0
28	0	78	-31 to 5.0
29	0 to 5.0	79	-31 to 5.0
30	0 to 5.0	80	-31 to 5.0
31	0 to 5.0	81	-31 to 5.0
32	0 to 5.0	82	-31 to 5.0
33	5.0	83	-31 to 5.0
34	5.0	84	-31 to 5.0
35	5.0	85	-31 to 5.0
36	5.0	86	-31 to 5.0
37	-31 to 5.0	87	-31 to 5.0
38	-31 to 5.0	88	-31 to 5.0
39	-31 to 5.0	89	-31
40	-31 to 5.0	90	0 to 5.0
41	-31 to 5.0	91	0 to 5.0
42	-31 to 5.0	92	0 to 5.0
43	-31 to 5.0	93	1.5
44	-31 to 5.0	94	0 to 5.0
45	-31 to 5.0	95	0 to 5.0
46	-31 to 5.0	96	0
47	-31 to 5.0	97	0
48	-31 to 5.0	98	5.0
49	-31 to 5.0	99	2.5
50	-31 to 5.0	100	0 to 5.0







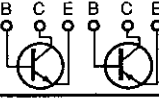

### K CNTB ASSY

IC501 (PD5764A)			
Pin No.	Voltage (V)	Pin No.	Voltage (V)
1	5.0	51	-31 to 5.0
2	5.0	52	-31 to 5.0
3	5.0	53	-31 to 5.0
4	5.0	54	-31 to 5.0
5	5.0	55	-31 to 5.0
6	5.0	56	-31 to 5.0
7	0 to 5.0	57	-31 to 5.0
8	0 to 5.0	58	-31 to 5.0
9	0	59	-31 to 5.0
10	0 to 5.0	60	-31 to 5.0
11	0 to 5.0	61	-31 to 5.0
12	0 to 5.0	62	-31 to 5.0
13	0 to 5.0	63	-31 to 5.0
14	0 to 5.0	64	-31 to 5.0
15	0	65	-31 to 5.0
16	0	66	-31 to 5.0
17	0	67	-31 to 5.0
18	5.0	68	-31 to 5.0
19	0	69	-31 to 5.0
20	0	70	-31 to 5.0
21	0	71	-31 to 5.0
22	0 to 4.0	72	-31 to 5.0
23	0 to 5.0	73	-31
24	0 to 5.0	74	-31
25	5.0	75	-31
26	0 to 5.0	76	-31 to 5.0
27	0 to 5.0	77	-31 to 5.0
28	0 to 5.0	78	-31 to 5.0
29	0 to 5.0	79	-31 to 5.0
30	0 to 5.0	80	-31 to 5.0
31	0 to 5.0	81	-31 to 5.0
32	0 to 5.0	82	-31 to 5.0
33	5.0	83	-31 to 5.0
34	5.0	84	-31 to 5.0
35	0 to 5.0	85	-31 to 5.0
36	0 to 5.0	86	-31 to 5.0
37	-31 to 5.0	87	-31 to 5.0
38	-31 to 5.0	88	-31 to 5.0
39	-31 to 5.0	89	-31
40	-31 to 5.0	90	0 to 5.0
41	-31 to 5.0	91	0 to 5.0
42	-31 to 5.0	92	0 to 5.0
43	-31 to 5.0	93	5.0
44	-31 to 5.0	94	0 to 5.0
45	-31 to 5.0	95	0 to 5.0
46	-31 to 5.0	96	5.0
47	-31 to 5.0	97	0
48	-31 to 5.0	98	5.0
49	-31 to 5.0	99	2.5
50	-31 to 5.0	100	0 to 5.0

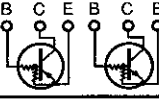
## 4. PCB CONNECTION DIAGRAM

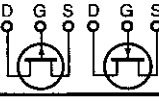
### NOTE FOR PCB DIAGRAMS :

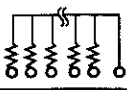
1. Part numbers in PCB diagrams match those in the schematic diagrams.
2. A comparison between the main parts of PCB and schematic diagrams is shown below.
3. The parts mounted on this PCB include all necessary parts for several destinations.  
For further information for respective destinations, be sure to check with the schematic diagram.
4. View point of PCB diagrams.

Symbol In PCB Diagrams	Symbol In Schematic Diagrams	Part Name
		Transistor
		Transistor with resistor
		Field effect transistor
		Resistor array
		3-terminal regulator

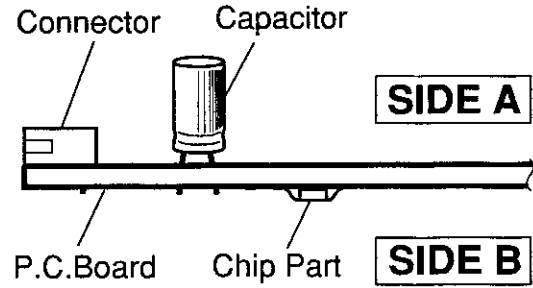



**D** SLM2 ASSY

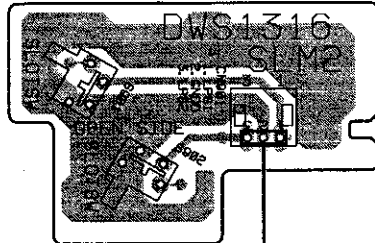

(DNP2002-C)

To Slot Mecha (B)  
Servo Mecha

To Slot Mecha (B)  
Loading Motor (J4)

To Slot Mecha (B)  
pick up Assy (CN1)

**SIDE A**

'201

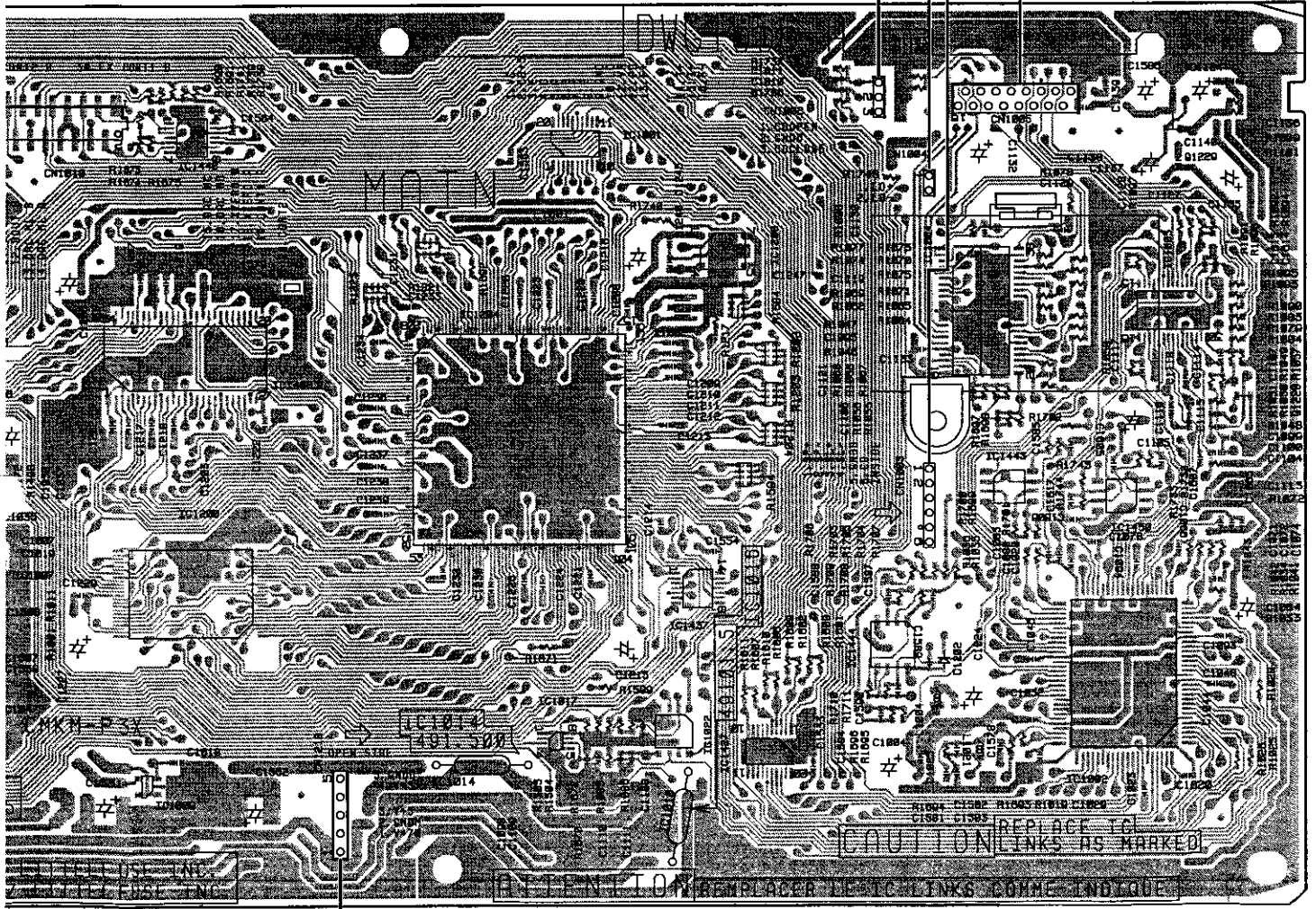

CAUTION: REPLACE IC REPLACER DE IC LINKS COMME INDIQUE

IC1440  
IC1408

IC1001  
IC1204

IC1208

IC1004  
IC1443

Q1229  
IC1003

IC1200  
IC1009

**F** CN104

IC1014 IC1017

IC1437  
IC1022 IC1427  
IC1016

IC1444 IC1443

IC1450 Q1228  
IC1002

7

**A D**

**SIDE B**

**A** MAIN ASSY

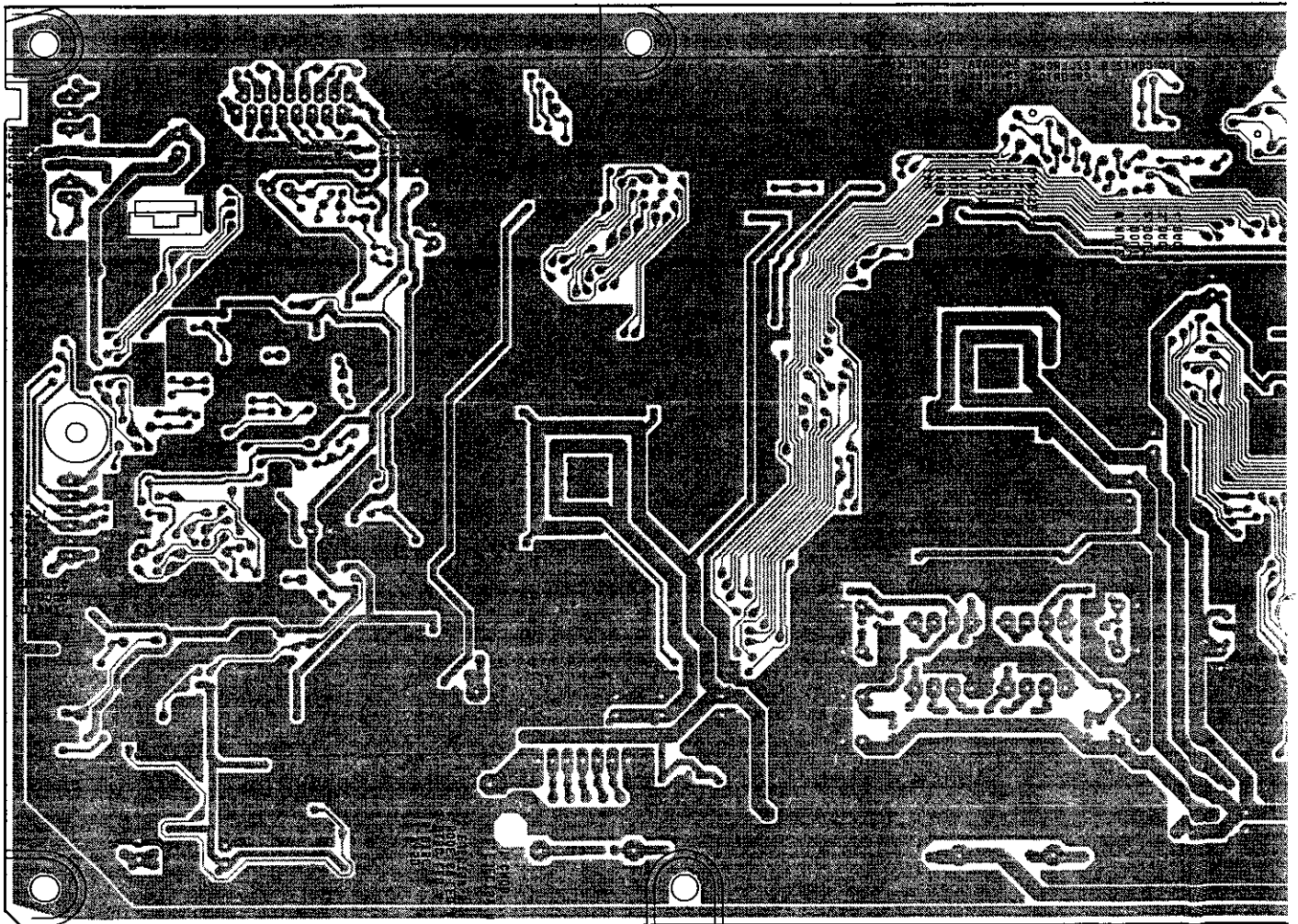

SIDE B

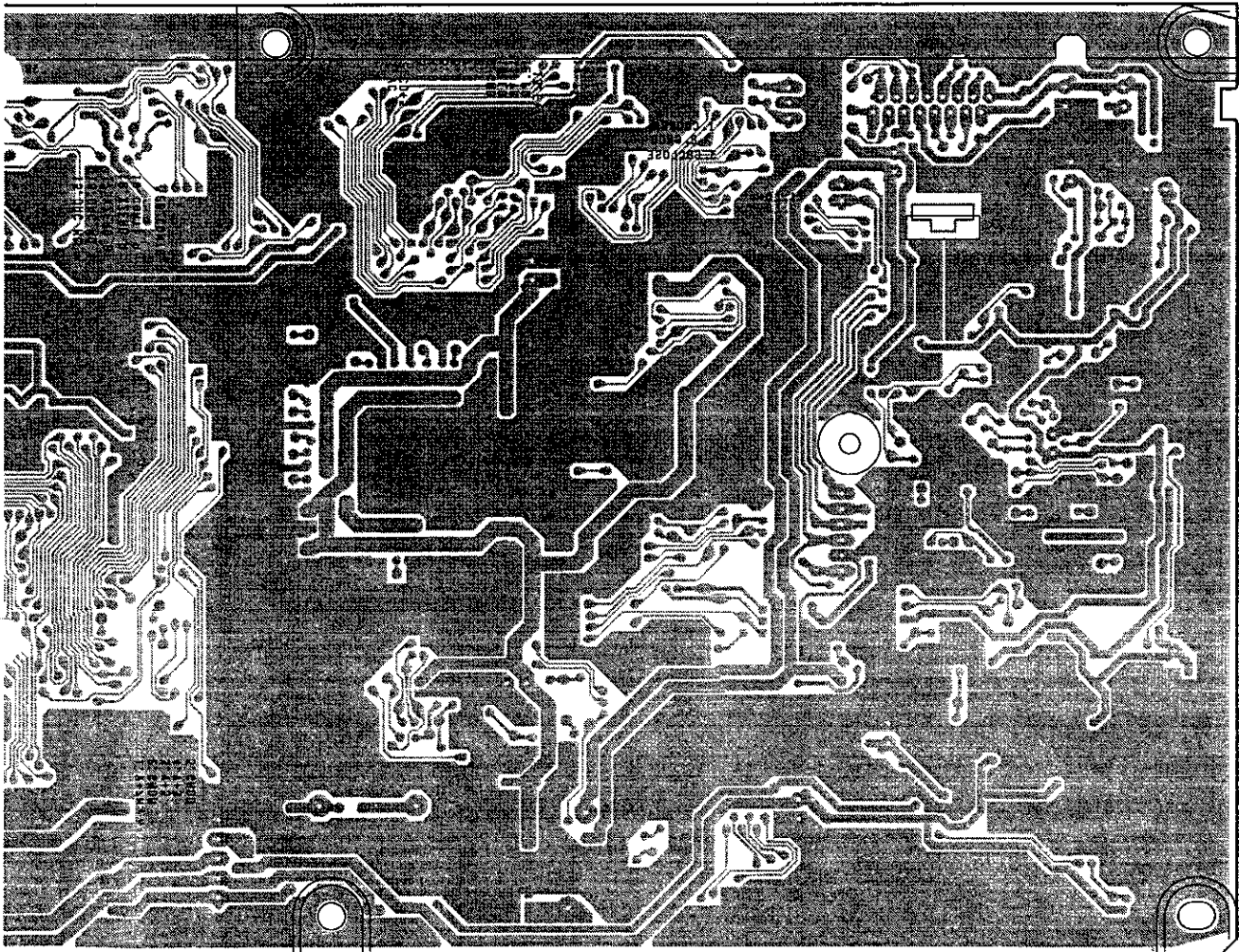

(DNP2003)





**E** JACB ASSY

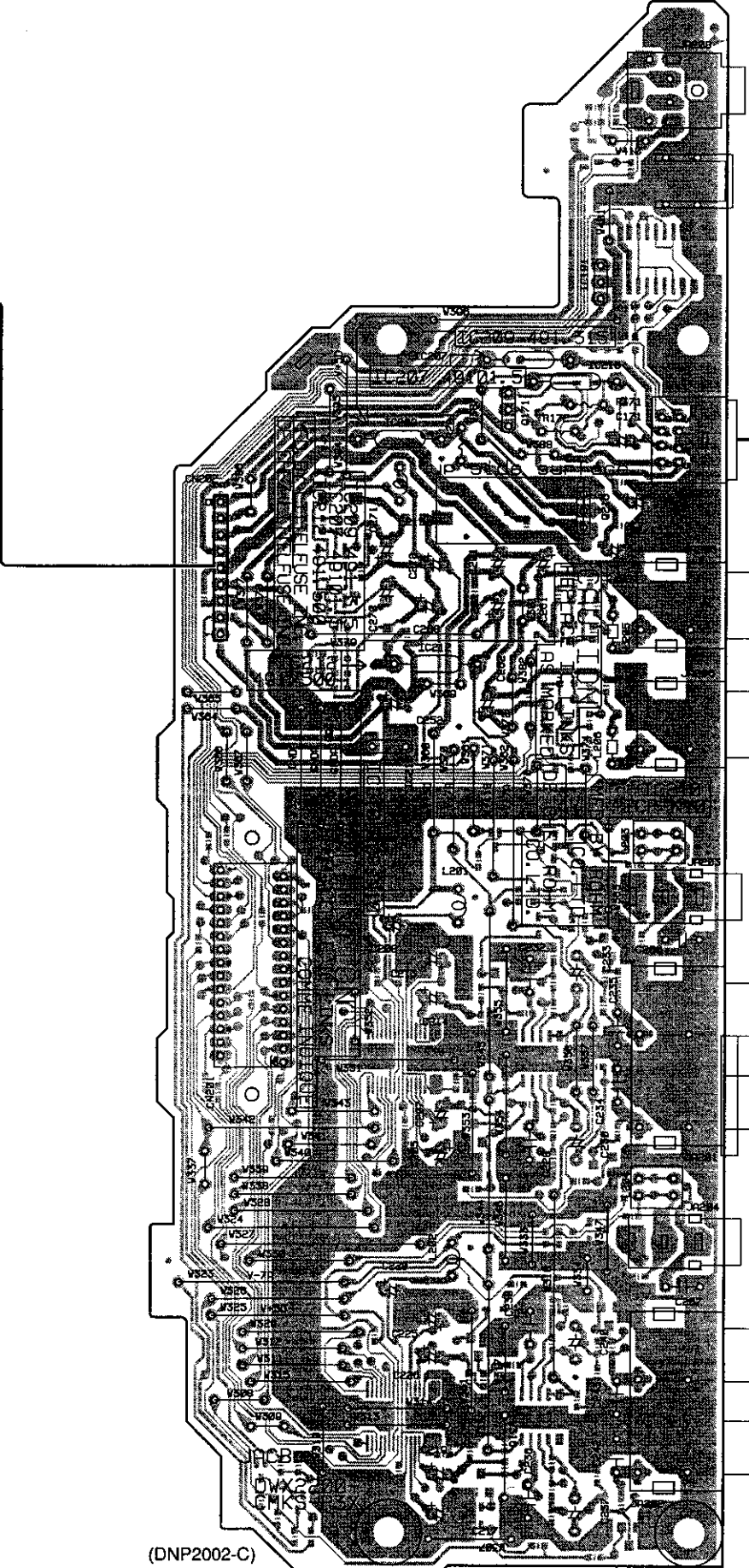

**M** JA701

**SIDE A**

- IC207
- IC213
- Q171
- IC209
- Q215
- IC212
- IC210

(DNP2002-C)



**E** JACB ASSY

IC172

**SIDE B**

- Q213
- Q214
- Q201
- Q202
- Q208
- Q207
- IC204 IC201
- Q205
- Q206
- Q212
- Q211
- IC205 IC202
- Q209 Q203
- Q210 Q204

(DNP2002-C)

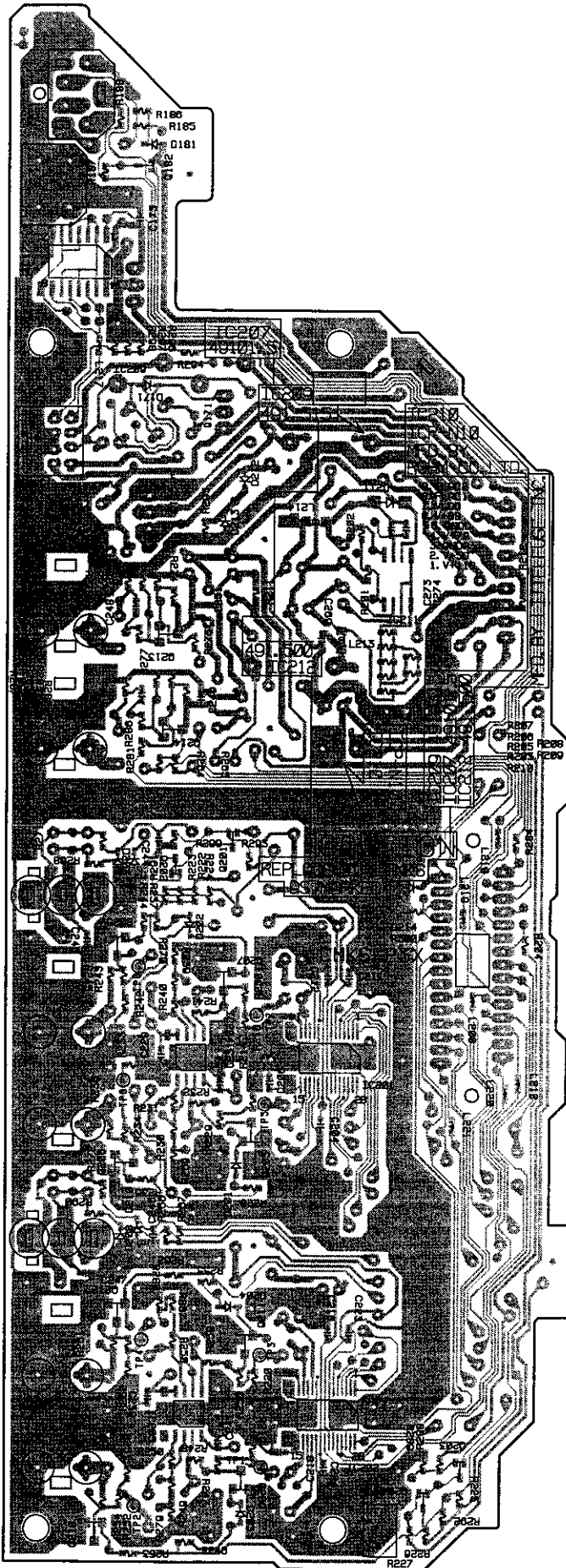



**4.3 CNTA and PHTA ASSYS**

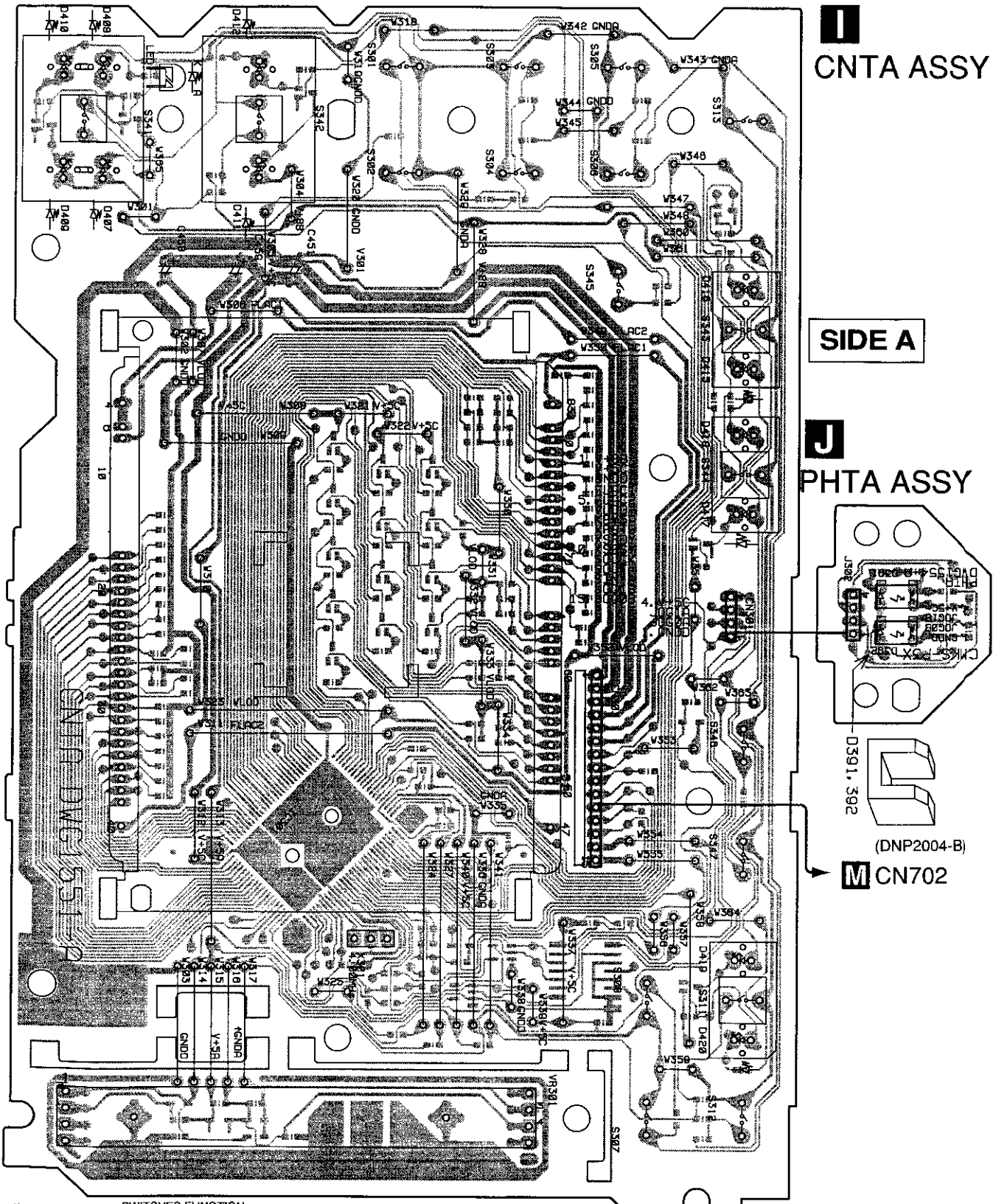

**I**  
**CNTA ASSY**

**SIDE A**

**J**  
**PHTA ASSY**

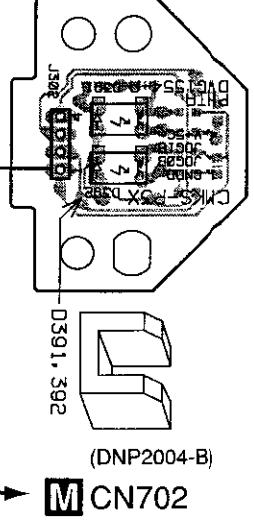

(DNP2004-B) SWITCHES FUNCTION

- |                            |                         |                        |
|----------------------------|-------------------------|------------------------|
| S301 : ▲                   | S307 : PITCH BEND [ + ] | S342 : CUE             |
| S302 : ▼                   | S308 : PITCH BEND [ - ] | S343 : IN/REALTIME CUE |
| S303 : ▲▼                  | S311 : MASTER TEMPO     | S344 : OUT/ OUT ADJ    |
| S304 : ▲▼                  | S312 : TEMPO            | S345 : JOG MODE        |
| S305 : AUTO CUE/ TIME MODE | S313 : ▲ (EJECT)        | S346 : RELOOP/ EXIT    |
| S306 : TEXT/ WAVE          | S341 : ►/■              | S347 : EMERGENCY LOOP  |

**I**  
CNTA ASSY

**SIDE B**

**J**  
PHTA ASSY

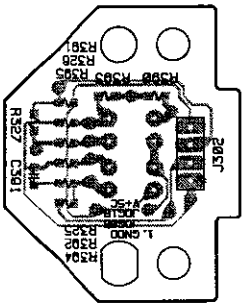

(DNP2004-B)

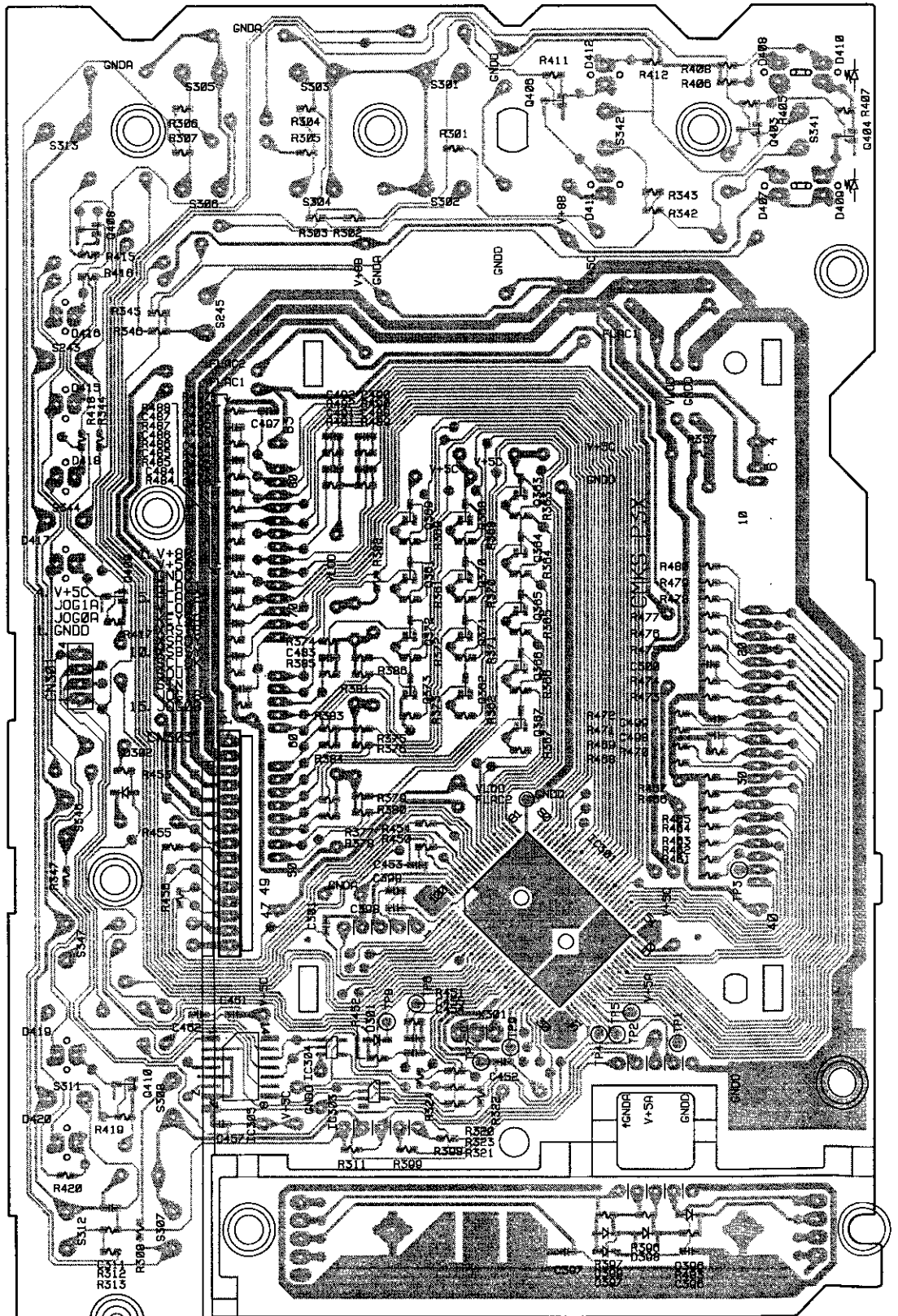

- |      |       |       |      |       |      |
|------|-------|-------|------|-------|------|
| Q408 | Q369  | Q368  | Q406 | Q403  | Q404 |
|      | Q361  | Q370  | Q363 |       |      |
|      | Q372  | Q371  | Q364 |       |      |
|      | Q373  | Q362  | Q365 |       |      |
| Q409 |       |       | Q366 |       |      |
| Q410 | IC305 | IC304 | Q367 | IC301 |      |
|      |       |       |      |       |      |

(DNP2004-B)

4.4 CNTB and PHTB ASSYS



SIDE A

**K** CNTB ASSY

(DNP2002-B)

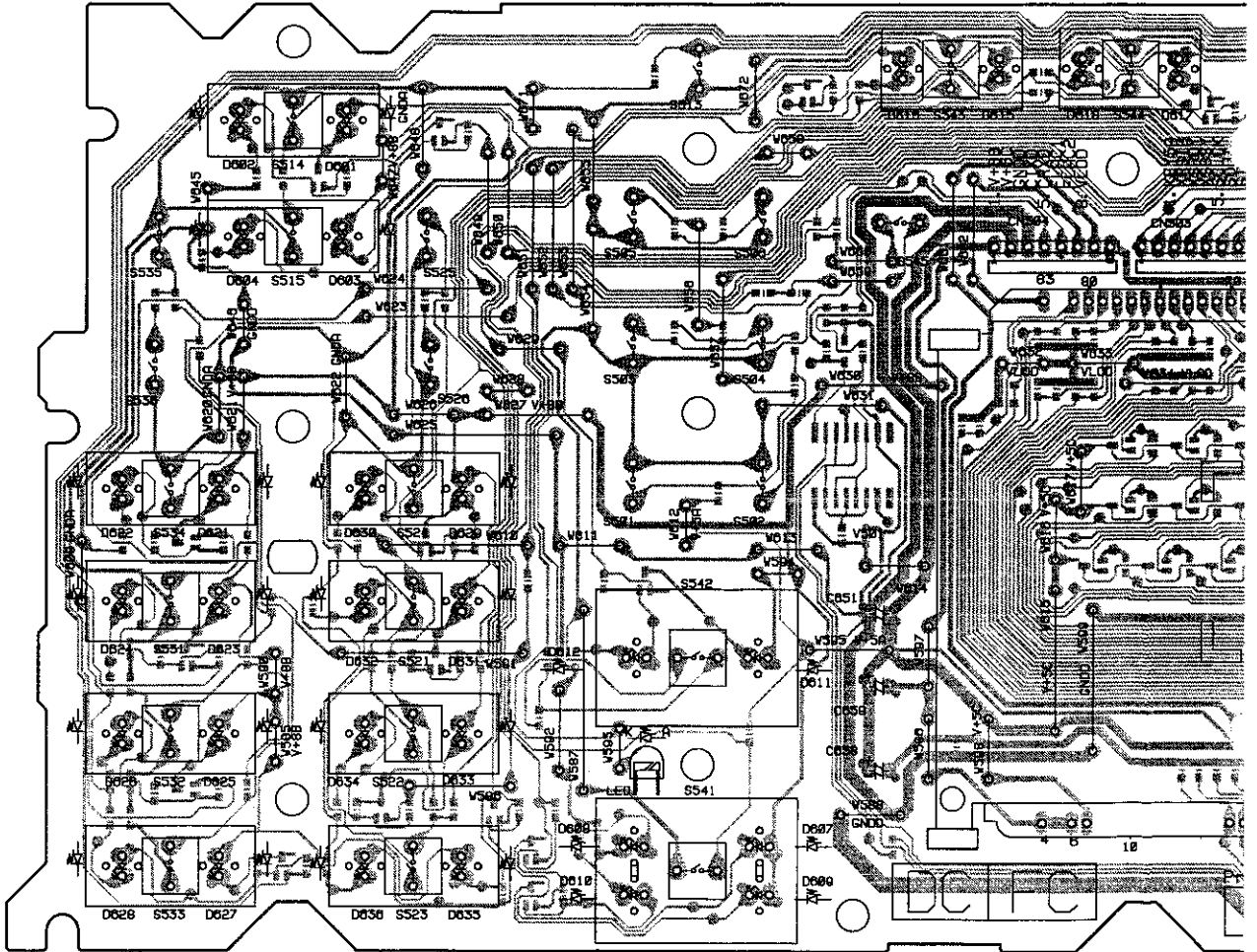

SWITCHES FINCTION

- S501 : ▲▲
- S502 : ▼▼
- S503 : ▲▲
- S504 : ▼▼
- S505 : AUTO CUE/TIME MODE
- S506 : TEXT/ WAVE
- S507 : PITCH BEND [ + ]
- S508 : PITCH BEND [ - ]

- S511 : MASTER TEMPO
- S512 : TEMPO RANGE
- S513 : ▲ (EJECT)
- S514 : BPM SYNC
- S515 : RELAY PLAY
- S521 : HOT CUE 1 - B
- S522 : HOT CUE 2 - B
- S523 : HOT CUE 3 - B

- S524 : HOT CUE REC - B
- S525 : BPM AUTO - B
- S526 : BPM TAP - B
- S531 : HOT CUE 1 - A
- S532 : HOT CUE 2 - A
- S533 : HOT CUE 3 - A
- S534 : HOT CUE REC - A
- S535 : BPM AUTO - A

- S536 : BPM TAP - A
- S541 : ▶/IT
- S542 : CUE
- S543 : IN/ REALTIME CUE
- S544 : OUT/ OUT ADJ
- S545 : JOG MODE
- S546 : RELOOP/ EXIT
- S547 : EMERGENCY LOOP



# L PHTB ASSY

SIDE A

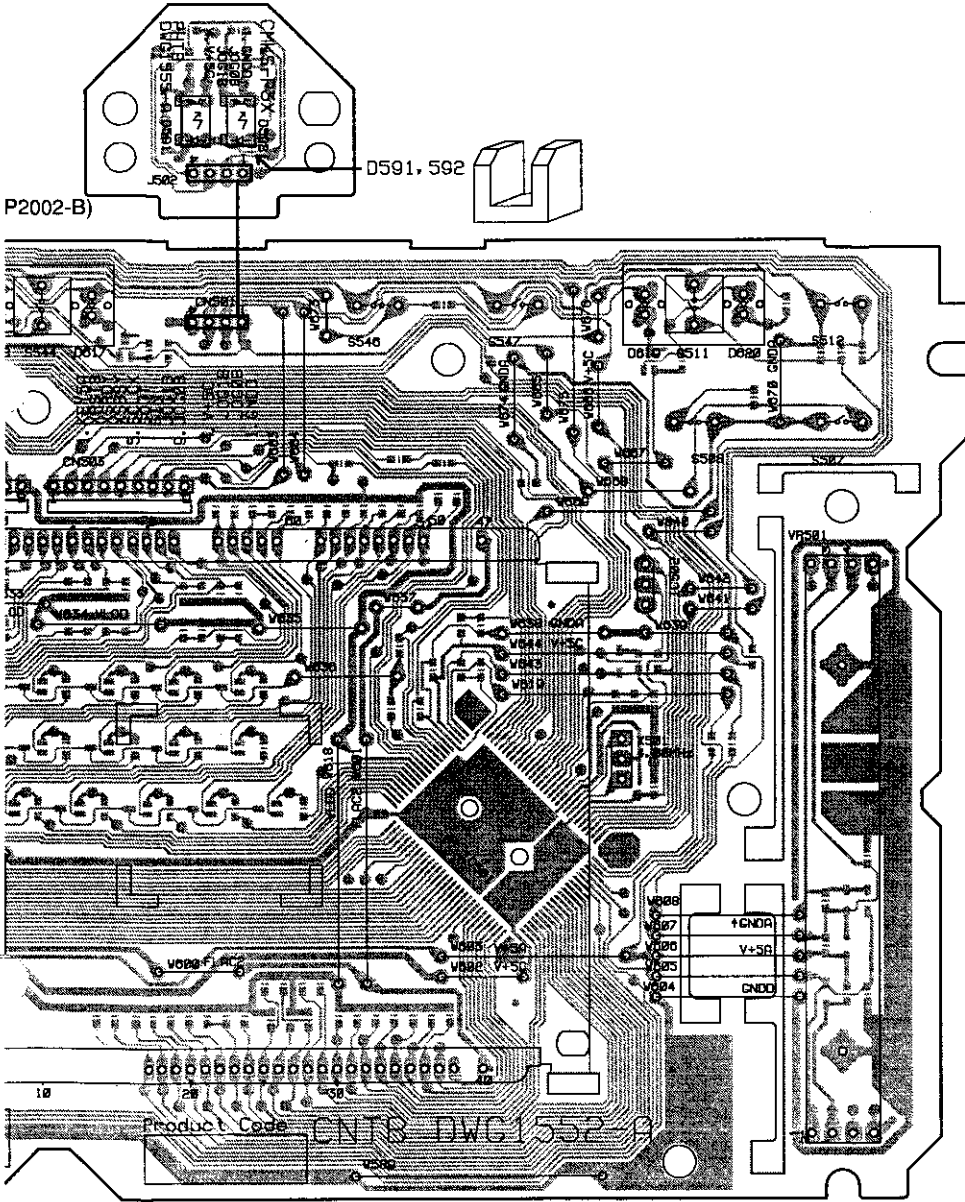

IC502 (DNP2002-B)

**4.5 CNTB, PHTB and CNNB ASSYS**

**M CNNB ASSY**

**SIDE A**

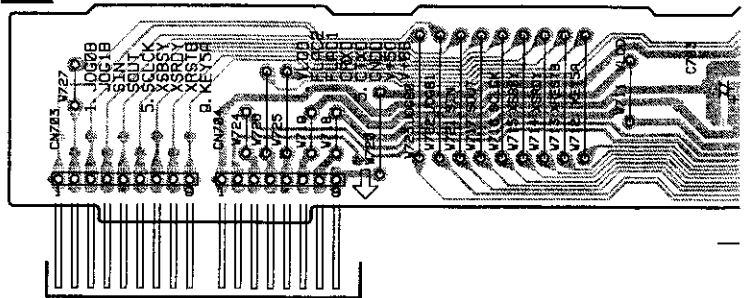

**L PHTB ASSY**

**SIDE B**

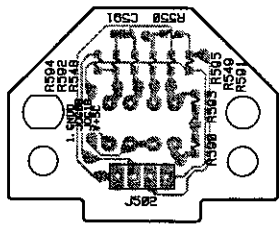

**K CNTB ASSY**

(DNP2004-B)

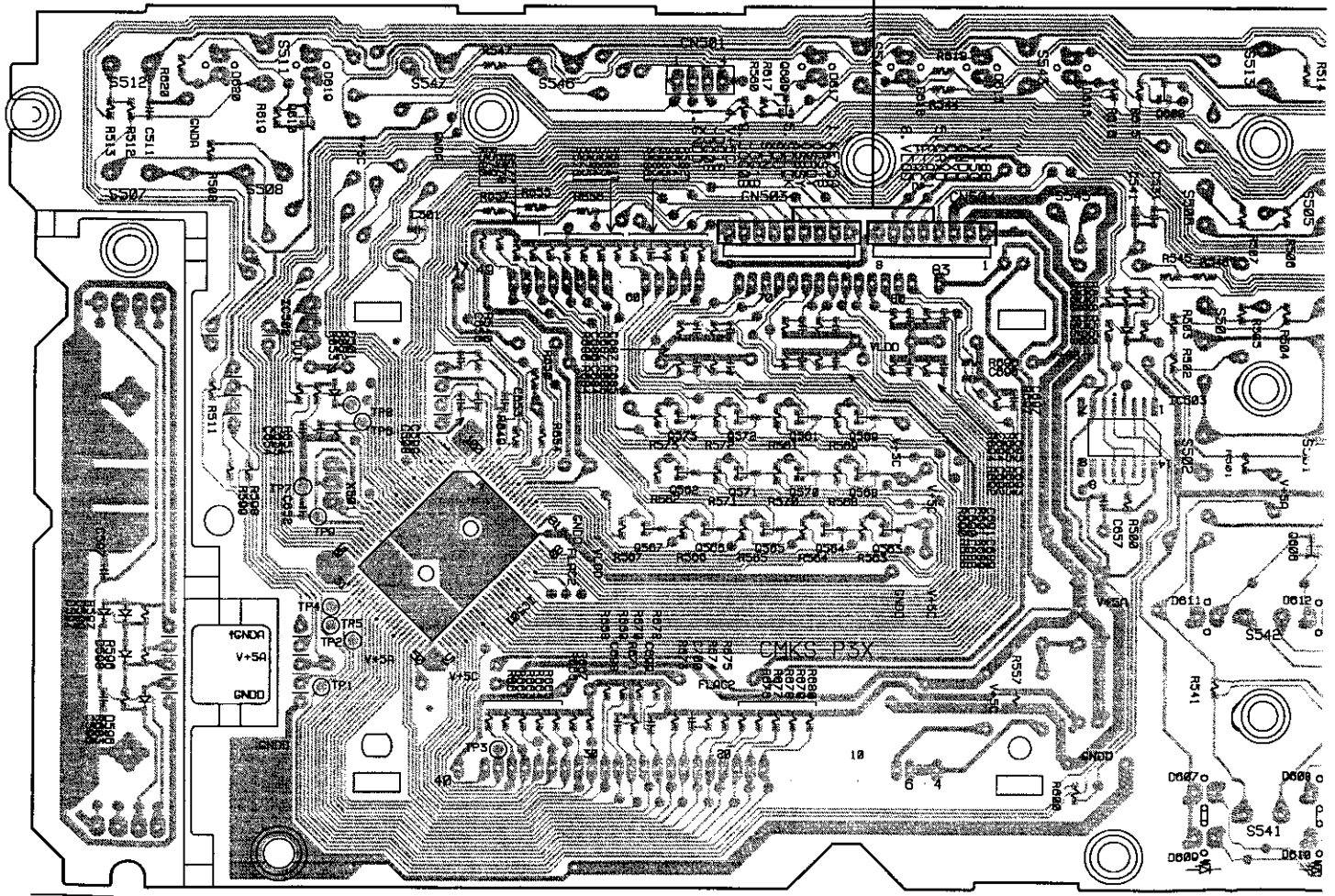

(DNP2004-B)

IC501

Q609  
 Q573 Q572 Q561 Q569  
 Q562 Q571 Q570 Q568  
 Q567 Q566 Q565 Q564 Q563

Q608  
 IC503

Q60



**E** JA207

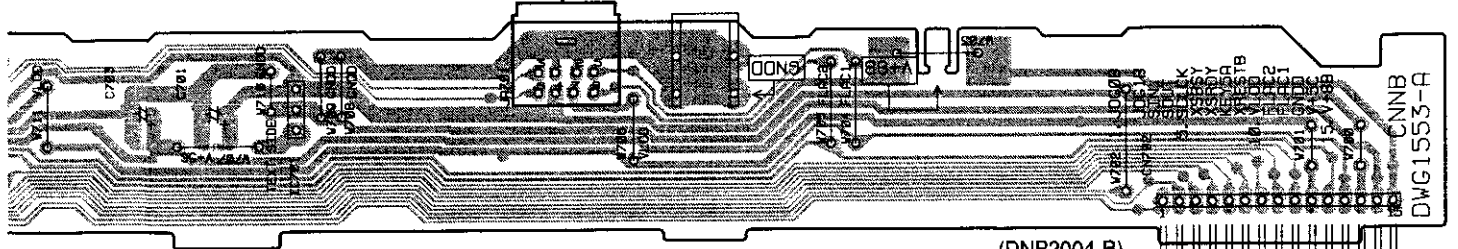

**SIDE A**

**I** CN303

**SIDE B**

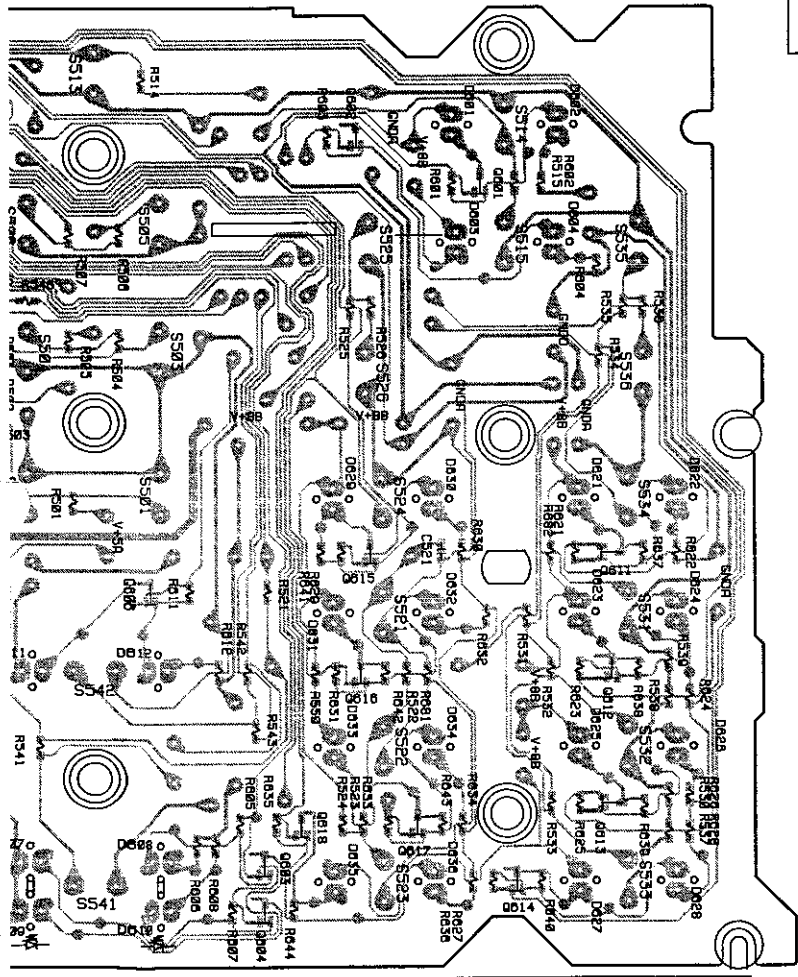

- Q606
- Q603
- Q604
- Q618
- Q602
- Q615
- Q616
- Q617
- Q601
- Q614
- Q611
- Q612
- Q613



## 5. PCB PARTS LIST

NOTES: ●Parts marked by "NSP" are generally unavailable because they are not in our Master Spare Parts List.

●The  $\Delta$  mark found on some component parts indicates the importance of the safety factor of the part. Therefore, when replacing, be sure to use parts of identical designation.

●When ordering resistors, first convert resistance values into code form as shown in the following examples.

Ex.1 When there are 2 effective digits (any digit apart from 0), such as 560 ohm and 47k ohm (tolerance is shown by J=5%, and K=10%).

560  $\Omega$   $\rightarrow$   $56 \times 10^1$   $\rightarrow$  561 ..... RD1/4PU  $\begin{matrix} 5 & 6 & 1 \\ \hline \end{matrix}$  J

47k  $\Omega$   $\rightarrow$   $47 \times 10^3$   $\rightarrow$  473 ..... RD1/4PU  $\begin{matrix} 4 & 7 & 3 \\ \hline \end{matrix}$  J

0.5  $\Omega$   $\rightarrow$  R50 ..... RN2H  $\begin{matrix} R & 5 & 0 \\ \hline \end{matrix}$  K

1  $\Omega$   $\rightarrow$  1R0 ..... RS1P  $\begin{matrix} 1 & R & 0 \\ \hline \end{matrix}$  K

Ex.2 When there are 3 effective digits (such as in high precision metal film resistors).

5.62k  $\Omega$   $\rightarrow$   $562 \times 10^1$   $\rightarrow$  5621 ..... RN1/4PC  $\begin{matrix} 5 & 6 & 2 & 1 \\ \hline \end{matrix}$  F

### • LIST OF WHOLE PCB ASSEMBLIES (FOR CMX-3000)

Mark	Symbol and Description	Part No.			Remarks
		CMX-3000/ KUCXJ	CMX-3000/ WYXJ	CMX-3000/ RLBXJ	
NSP	MAIN ASSY	DWG1556	DWG1556	DWG1556	*1
	POWB ASSY	DWM2130	DWM2127	DWM2131	
	└ PWRB ASSY	DWR1345	DWR1345	DWR1348	
	└ ACIN ASSY	DWR1349	DWR1346	DWR1346	
	└ REGB ASSY	DWR1357	DWR1347	DWR1347	
	└ FRSW ASSY	DWS1314	DWS1314	DWS1314	
	└ SLM1 ASSY	DWS1315	DWS1315	DWS1315	
	└ SLM2 ASSY	DWS1316	DWS1316	DWS1316	
	└ JACB ASSY	DWX2214	DWX2200	DWX2200	

\*1: Although DWR1357 and DWR 1347 are different in part number, they consist of the same components.

\*2: Although DWX2214 and DWX2200 are different in part number, they consist of the same components.

### • LIST OF PCB ASSEMBLIES (FOR CU-V163)

NSP	CONT ASSY	DWM2129
	└ CNTA ASSY	DWG1551
	└ CNTB ASSY	DWG1552
	└ CNNB ASSY	DWG1553
	└ PHTA ASSY	DWG1554
	└ PHTB ASSY	DWG1555

### • CONTRAST OF PCB ASSEMBLIES

#### **F** PWRB ASSY

DWR1345 and DWR1348 are constructed the same except for the following:

Mark	Symbol and Description	Part No.		Remarks
		DWR1345	DWR1348	
	S105 (Voltage Selector)	Not used	DSA1026	

#### **H** ACIN ASSY

DWR1349 and DWR1346 are constructed the same except for the following:

Mark	Symbol and Description	Part No.		Remarks
		DWR1349	DWR1346	
	AN101 (Power Socket)	AKP7032	Not used	
	AN101 (1P AC Inlet)	Not used	BKP1046	



# CMX-3000, CU-V163

Mark	No.	Description	Part No.
	CN1003, CN1007	CONNECTOR	B6B-PH-K-S
	X1002	CRYSTAL RESONATOR(12MHz)	DSS1132
	CN1010	CONNECTOR	VKN1626
	X1001	CRYSTAL RESONATOR(16.9MHz)	VSS1084

## B FRSW ASSY

### SEMICONDUCTORS

D 161 ,D 162	SLR-343MC(NPQ)
D163	SLR-343VC(NPQ)

### SWITCHES

S161, S162	ASG7013
S163	DSH1049

### CAPACITORS

C161	CKSRYB103K50
------	--------------

### RESISTORS

Other Resistors	RS1/16S□□□ J
-----------------	--------------

### OTHERS

161	7P CABLE HOLDER	51048-0700
J 161	JUMPER WIRE	D20PDY0720E

## C SLM1 ASSY

### SWITCHES AND RELAYS

S801, S802	DSG1017
------------	---------

### OTHERS

CN801	CONNECTOR POST	S3B-PH-K-S
-------	----------------	------------

## D SLM2 ASSY

### SWITCHES AND RELAYS

S901, S902	DSG1017
------------	---------

### OTHERS

CN901	CONNECTOR POST	S3B-PH-K-S
-------	----------------	------------

## E JACB ASSY

### SEMICONDUCTORS

△ IC209 (315 mA)	AEK7059
△ IC212 (500 mA)	AEK7060
△ IC207 (1.5 A)	AEK7065
△ IC210 (0.4 A)	ICP-N10
IC211	NJM2360M

IC204, IC205	NJM4558MD
IC181	NJM78L05A
IC201, IC202	PE8001A
IC172	TC74ACT04F
Q171	2SB1237X

Q215	2SB1375
Q213, Q214	2SC2412K
Q205-Q212	2SD2114K
Q 201 ,Q 203	DTA124EUA
Q182	DTA143EUA

Mark	No.	Description	Part No.
	Q 202 ,Q 204		DTC124EUA
	D181, D201-D204		1SS355
	D211		EC10QS04
	D212		UDZ33B
	D 205 ,D 207 ,D 208 ,D 210		UDZS10B

D214	UDZS5.1B
D171	UDZS8.2B

### COILS AND FILTERS

L215	DTL1083
L213, L214	LCTA470J2520
L201, L202	LRCA4R7J
L208, L212, L217-L221	VTL1084

### CAPACITORS

C273	CCSRCH181J50
C274	CCSRCH220J50
C202, C208, C220, C268	CEAT101M10
C270, C271	CEAT101M10
C171	CEAT1R0M50

C275	CEAT330M50
C207, C214, C219, C226, C262	CEAT470M16
C205, C213, C217, C225	CEAT470M25
C172	CEAT470M50
C201, C261, C272	GEHAR330M10

C230, C233, C237, C240	CEJQNP220M16
C266, C267	CKCYF103Z50
C248, C250	CKSRYB103K50
C173, C204, C206, C211, C212	CKSRYB104K25
C216, C218, C223, C224, C229	CKSRYB104K25

C231, C239, C241, C244-C247	CKSRYB104K25
C249, C251, C269	CKSRYB104K25
C276	CKSRYB473K50
C228, C232, C234-C236, C238	CQMA152J50
C242, C243	CQMA152J50

### RESISTORS

R221	RD1/2VM222J
R171, R172	RD1/2VM560J
R231, R240, R250, R258	RN1/16SE2202D
R201	RS1/16S2202F
R202	RS1/16S4701F

### Other Resistors

RS1/16S□□□ J

### OTHERS

208	JACK	AKN7003
JA201, JA202	2P JACK	DKB1053
JA205, JA206	JACK BOARD	PKB1033
JA203, JA204	JACK/12V	PKN1004
207	I/O JACK	VKN1070

CN201	B TO B CONNECTOR 30P	VKN1627
0	SCREW PLATE	VNE1948
	PCB BINDER	VEF1040

Mark No. Description Part No.

**F PWRB ASSY**

**SEMICONDUCTORS**

△	IC104 (800 mA)	AEK7008
△	IC107 (1.5 A)	AEK7011
△	IC101 (4 A)	AEK7018
△	IC103 (5 A)	AEK7019
△	IC108 (315 mA)	AEK7059
△	IC106 (1.5 A)	ICP-N38
△	D 103 -D 106	1SR154-400
△	D102	D3SBA20(B)
△	D111-D114	RB060L-40
△	D107-D110	RB160L-40

**COILS AND FILTERS**

△	L101	VTL-004
---	------	---------

**CAPACITORS**

△	C103 (0.01 μF/ AC275V )	ACE7027
	C 125 -C 127	CEAT101M10
	C123	CEHAT221M2A
	C124	CEHAT472M16
	C121	CEHAT472M25
	C122	CEHAT682M16
	C104-C108, C110-C113	CKSRYB473K50
	C128-C136	CKSRYB473K50

**RESISTORS**

Other Resistors	RS1/16S□□□ J
-----------------	--------------

**OTHERS**

△	CN106 9P JUMPER CONNECTOR	52147-0910
	CN103 SOCKET 4P	AKP7132
	CN104 5P TOP POST	B5B-EH
	CN105 9P TOP POST	B9B-EH
0	SCREW PLATE	VNE1948

**G ACIN ASSY**

**SWITCHES AND RELAYS**

△	S101	RSA1001
---	------	---------

**CAPACITORS**

△	C102 (0.01μF/ AC275V)	ACE7027
△	C101 (10000PF/AC250V)	ACG7033

**OTHERS**

△	CN102	PLUG 4P	AKM7055
△	AN101	POWER SOCKET	AKP7032
△	H101, H102	FUSE CLIP	AKR1004

Mark No. Description Part No.

**H REGB ASSY**

**SEMICONDUCTORS**

△	IC153	BA033T
△	IC152	BA05T
△	IC151	PQ15RW21

**CAPACITORS**

C155, C156	CEHAT101M10
C154	CEHAT470M16
C151-C153	CKSRYB103K50

**RESISTORS**

R152	RN1/16SE2201D
R151	RN1/16SE3901D

**OTHERS**

151	9P CABLE HOLDER	51048-0900
J 151	JUMPER WIRE	D20PDY0910E
0	REGURATOR PLATE	DNH2507
	SCREW	BBZ30P060FMC

# CMX-3000, CU-V163

Mark	No.	Description	Part No.
------	-----	-------------	----------

## I CNTA ASSY

### SEMICONDUCTORS

IC301  
IC305  
IC303, IC304  
Q361-Q373, Q403, Q404, Q406  
Q408-Q410

PD5764A  
TC74HC14AF  
TC7S86F  
2SC4081  
2SC4081

D301, D302, D396-D399  
D411, D412  
D415-D420  
D407-D410

1SS355  
SLI-343URCW(RST)  
SLI-343YCW(RST)  
TLGE68TG(NP)

### SWITCHES

S301-S308, S311-S313  
S341-S347

ASG7013  
ASG7013

### CAPACITORS

C451  
C458  
C459  
C301, C311, C396-C399  
C452-C455, C457

CEAT101M10  
CEAT1R0M50  
CEAT220M50  
CKSRYB102K50  
CKSRYB103K50

C483-C500  
C461, C462

CKSRYB221K50  
CKSRYB471K50

### RESISTORS

R396, R397  
VR301 (50kΩ-B x2)  
Other Resistors

RS1/16S2201F  
DCV1011  
RS1/16S□□□ J

### OTHERS

CN303 CONNECTOR  
CN301 4P JUMPER CONNECTOR  
V301 VACUUM FL DISPLAY  
X301 CERAMIC RESONATOR  
FL HOLDER

52084-1510  
52147-0410  
DEL1047  
DSS1131  
DNK3956

## J PHTA ASSY

### SEMICONDUCTORS

D391, D392

GP1S94

### CAPACITORS

C391

CKSRYB103K50

### RESISTORS

Other Resistors

RS1/16S□□□ J

### OTHERS

J 302 JUMPER WIRE

D20PWY0415E

## K CNTB ASSY

### SEMICONDUCTORS

IC501  
IC502  
IC503  
Q561-Q573, Q601-Q604, Q606  
Q608-Q618

PD5764A  
PST994D  
TC74AC04F  
2SC4081  
2SC4081

D501, D596-D599  
D611, D612, D621, D 622  
D629, D 630  
D601-D604, D615-D620

1SS355  
SLI-343URCW(RST)  
SLI-343URCW(RST)  
SLI-343YCW(RST)

Mark	No.	Description	Part No.
------	-----	-------------	----------

D623-D628, D631-D636

SLI-343YCW(RST)

D607-D610  
D590

TLGE68TG(NP)  
UDZS5.1B

### SWITCHES

S501-S508, S511-S515  
S521-S526, S531-S536  
S541-S547

ASG7013  
ASG7013  
ASG7013

### CAPACITORS

C651  
C658  
C659  
C501, C511, C521, C531, C541  
C596-C599, C656

CEAT101M10  
CEAT1R0M50  
CEAT220M50  
CKSRYB102K50  
CKSRYB102K50

C652-C655, C657  
C683-C700

CKSRYB103K50  
CKSRYB221K50

### RESISTORS

R596, R597  
VR501 (50kΩ-B x2)  
Other Resistors

RS1/16S2201F  
DCV1011  
RS1/16S□□□ J

### OTHERS

CN504 CONNECTOR  
CN503 CONNECTOR  
CN501 4P JUMPER CONNECTOR  
V501 VACUUM FL DISPLAY  
X501 CERAMIC RESONATOR (4MHz)  
FL HOLDER

52084-0810  
52084-0910  
52147-0410  
DEL1047  
DSS1131  
DNK3956

## L PHTB ASSY

### SEMICONDUCTORS

D591, D592

GP1S94

### CAPACITORS

C591

CKSRYB103K50

### RESISTORS

Other Resistors

RS1/16S□□□ J

### OTHERS

J 502 JUMPER WIRE

D20PWY0415E

## M CNNB ASSY

### SEMICONDUCTORS

IC701

BA05T

### CAPACITORS

C703  
C701  
C702, C704

CEAT101M10  
CEAT101M16  
CKSRYB103K50

### OTHERS

CN704 CONNECTOR 8P  
CN703 CONNECTOR 9P  
CN702 CONNECTOR 15P  
0 I/O JACK  
0 SCREW PLATE

53095-0810  
53095-0910  
53095-1510  
VKN1070  
VNE1948

## 6. ADJUSTMENT

### 6.1 ADJUSTMENT ITEMS AND LOCATION

#### ■ Adjustment Points (PCB Part)

**A** MAIN ASSY

SIDE A

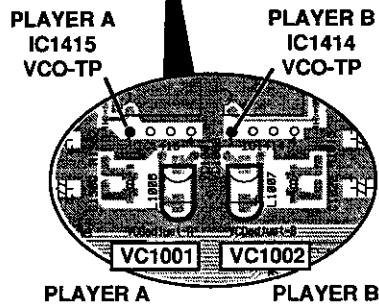
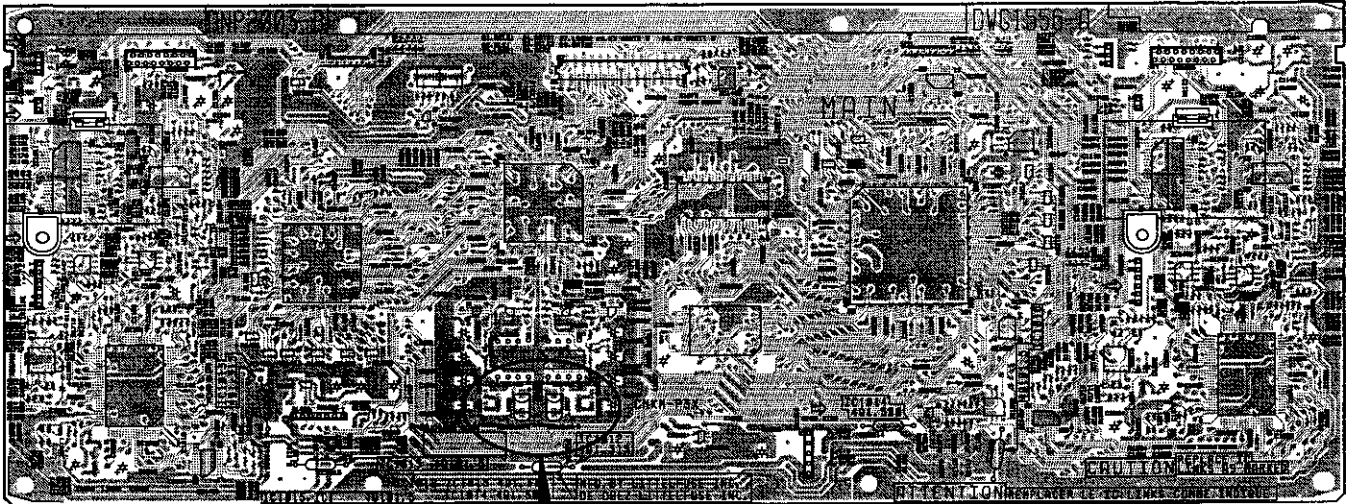

#### ■ Adjustment Items

[Electrical Part]

- ① VCO Free-running Adjustment

### 6.2 JIGS AND MEASURING INSTRUMENTS

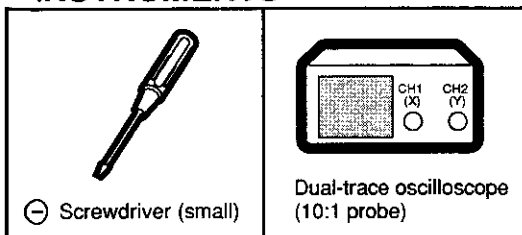

### 6.3 NECESSARY ADJUSTMENT POINTS

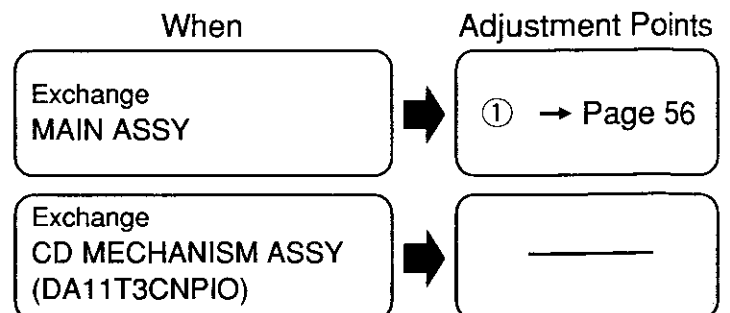

## 6.4 ELECTRICAL ADJUSTMENT

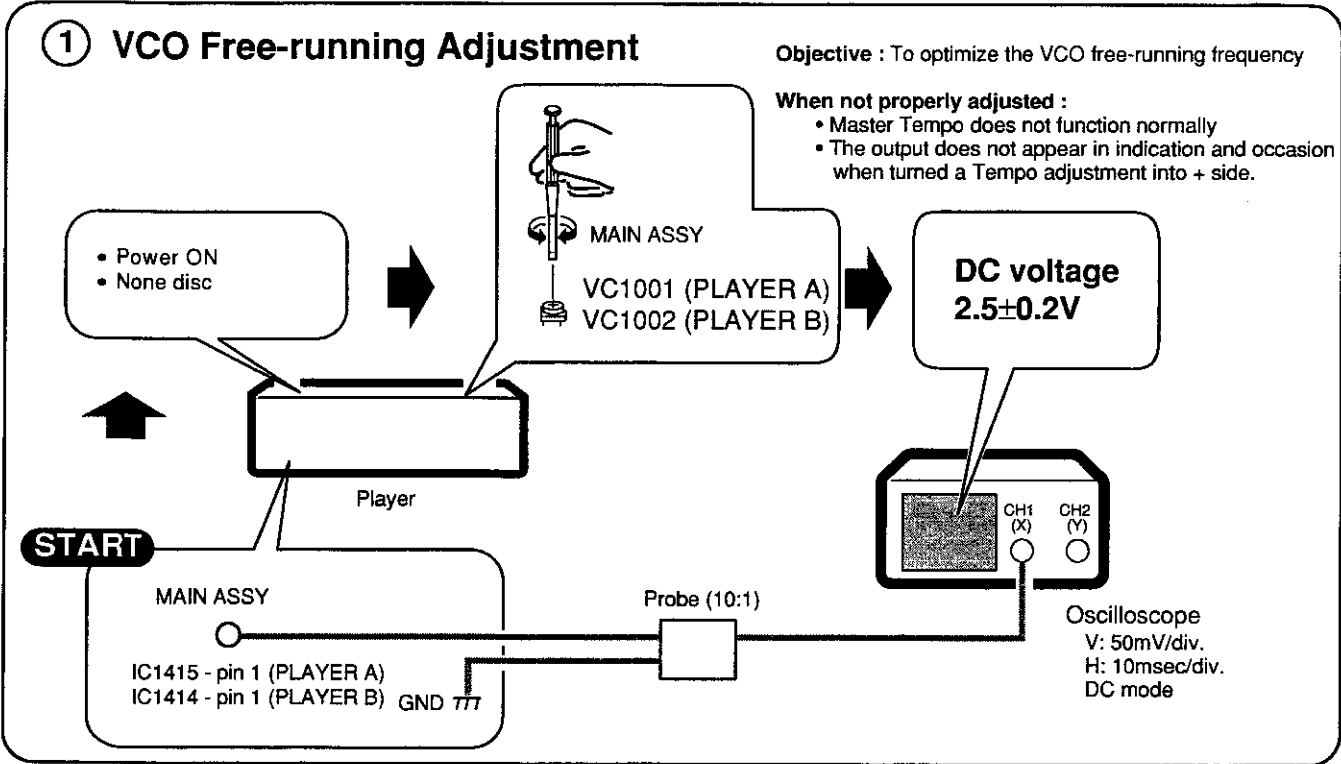



## 7. GENERAL INFORMATION

### 7.1 DIAGNOSIS

#### 7.1.1 SERVICE MODE

##### ■ Outline of the Service Mode

This unit prepares the test mode in the controller and player sections.

##### ① Confirmation mode of the controller button and display function

There are following two ways in the mode confirming the controller button and display function.

Mode 1: When connect the Controller section to the Player, and confirm it.

Mode 2: When connect the power supply to Controller section being simple, and confirm it.

Basic operation is the same with both modes, but FL does not light.

##### ② The mode which confirms the operation with the player being simple (Use the remote control unit.)

Connect the Remote control unit (RU-V101) to a DATA IN/OUT terminal of the Player and confirms the operation.

##### ③ State confirmation mode with the system operation

Confirm the software version of each microcomputer and active state with the display.

##### ■ Confirmation Mode of the Controller Button and Display Function

###### • Mode 1

Enter this mode when turns the power on while pressing the AUTO button of each player simultaneously.

Mode 1 can confirm the state of each other button with FL other than the operation of mode 2.

###### • Mode 2

Enter this mode when connects a screw terminal to GND and +8V from the external DC power supply to V+8B by controller section being simple. Further, it is not necessary to press buttons in the power-up.

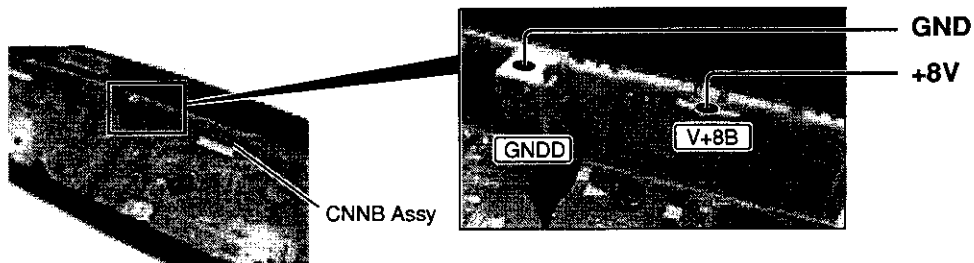
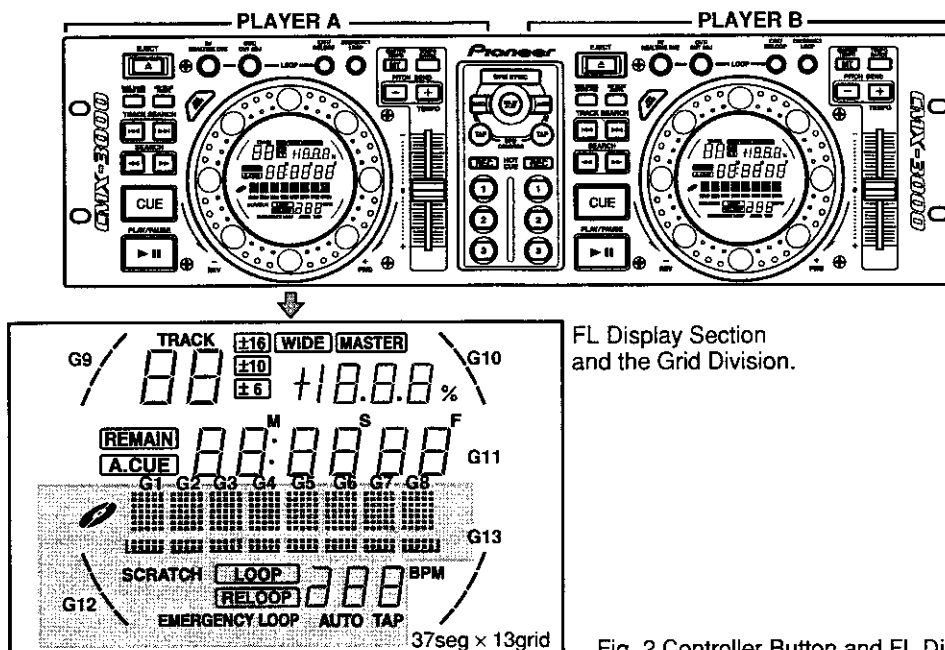

Fig.1 External DC Power Supply Connection Position

**Note :** Mode 1 and mode 2 are the same operations basically. But a power supply of FL system is not supplied in case of mode 2. Therefore cannot confirm it with FL.

Explain the operation about mode 1 here. (Mode 2 is the same except that FL of mode 1 does not light.)



FL Display Section and the Grid Division.

Fig. 2 Controller Button and FL Display Section

# CMX-3000, CU-V163

## • Confirm the FL display operation

In mode 1, display the demonstration display of fixed pattern and display 1/2 light, all lighting and all lights out repeatedly. In addition, display the button name in dot matrix of Grid 1 to Grid 8 while a button is pressed.

## • Confirm the each button operation

Corresponding two LED lights when pressed the button of each player.

Relation of LED corresponding to each button is the following matrix, and vertical scale of each button and button LED corresponding to horizontal scale light it.

For example, "CUE" button LED of player B and "HOT CUE ①" button LED of player A light it when pressed "EJECT" button of player B.

When "BPM SYNC" and "RELAY PLAY" button were pressed, "CUE" button LED of player B and "HOT CUE (REC)" button LED of player A and "HOT CUE ③" button LED of player B light it.

	PLAY/PAUSE (▶/■) Button LED of Each Player	CUE Button LED of Each Player	IN/REALTIME CUE Button LED of Each Player	OUT/OUT ADJ Button LED of Each Player
HOT CUE ③_a Button LED	SERCH (◀◀)	MASTER TEMPO	HOT CUE ①	PLAY/PAUSE (▶/■)
HOT CUE ②_a Button LED	SERCH (▶▶)	TEMPO RANGE	HOT CUE ②	CUE
HOT CUE ①_a Button LED	TRACK SERCH (◀◀)	EJECT	HOT CUE ③	IN/REALTIME CUE
HOT CUE (REC)_a Button LED	TRACK SERCH (▶▶)	BPM SYNC (Player B)	HOT CUE (REC)	OUT/OUT ADJ
HOT CUE ③_b Button LED	TIME MODE / AUTO CUE	RELAY PLAY (Player B)	AUTO	JOG MODE
HOT CUE ②_b Button LED	CD TEXT / WAVE		TAP	EXIT/RELOOP
HOT CUE ①_b Button LED	PITCH BEND (+)			EMERGENCY LOOP
HOT CUE (REC)_b Button LED	PITCH BEND (-)			

In the mode 1, display the button name to correspond in dot matrix in the FL.

Button	FL Display	Button	FL Display
SEARCH (◀◀) Button	SERCH ◀◀	HOT CUE ① Button	HOTCUE 1
SEARCH (▶▶) Button	SERCH ▶▶	HOT CUE ② Button	HOTCUE 2
TRACK SEARCH (◀◀) Button	TRACK ◀◀	HOT CUE ③ Button	HOTCUE 3
TRACK SEARCH (▶▶) Button	TRACK ▶▶	HOT CUE (REC) Button	HOT REC
TIME MODE / AUTO CUE Button	TIME/CUE	AUTO Button	AUTO
CD TEXT / WAVE Button	TEXTWAVE	TAP Button	TAP
PITCH BEND (+) Button	PITCH +	PLAY/PAUSE (▶/■) Button	PLAY
PITCH BEND (-) Button	PITCH -	CUE Button	CUE
MASTER TEMPO Button	M.T *** (Note *1)	IN/REALTIME CUE Button	LOOP IN
TEMPO RANGE Button	TEMPO *** (Note *1)	OUT/OUT ADJ Button	LOOP OUT
EJECT (▲) Button	EJECT	JOG MODE Button	JOG MODE
BPM SYNC Button	BPM SYNC *2	EXIT/RELOOP Button	RELOOP
RELAY PLAY Button	RELAY PL *2	EMERGENCY LOOP Button	EM. LOOP

**Note** \*1 : Reading value of the TEMPO slider (+10 to 0 to -10) displays in \* \* \*.

\*2 : Display in FL of the player B side.

## • Confirm the JOG operation

Button LED corresponding to each JOG blinks when turned JOG.

When JOG of player A side moves: RELAY PLAY button LED light or turn off the light in the state of the JOG address that read in.

When JOG of player B side moves: BPM SYNC button LED light or turn off the light in the state of the JOG address that read in.

## • Confirm the each button LED

In this unit, all button LED light fixed time at the power-up.

In addition, it can confirm the lighting state by performing the "Confirm the each button operation", "Confirm the JOG operation" and "Confirm the TEMPO slider".

• **Confirm the TEMPO slider**

In the position which read-in from the TEMPO slider, MT button LED lights at + side, and MT button LED turns off the light at - side.

However, there is a case that lights or turns off the light for unevenness of parts of TEMPO slider at the center tap periphery. In addition, when TEMPO button and MT button were pressed in mode 1, match with button name in dot matrix in the FL, and display reading value of TEMPO slider by a value of +10 to 0 to -10.

■ **Confirmation Mode of Operation with the Player Being Simple**

Connect the remote control unit (RU-V101) to DATA IN/OUT terminal of the Rear panel of the player section, and confirm the operation.

When use the remote control unit, remove a connection cable with the control section before power-up, then connect the remote control unit.

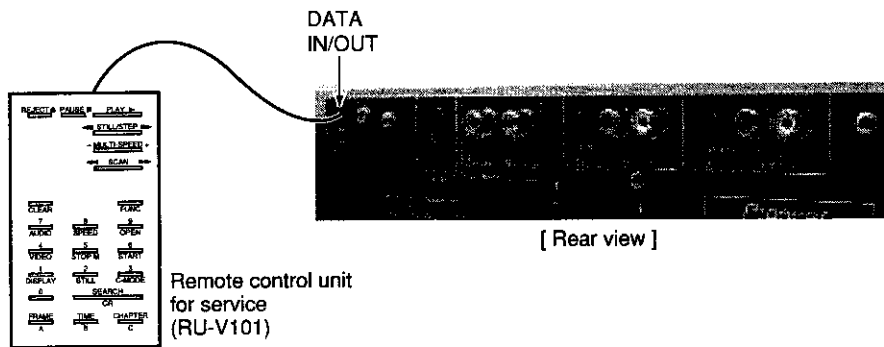

Fig. 3 Connection of the Remote Control Unit for Service

• **Function of the remote control unit (RU-V101) for service**

	Button Corresponding to RU-V101	Digital SW OFF in CDJ Mode	Digital SW ON in Digital Mode
Player Select	STOP. M (FUNC + 5)	○	○
A Time Mode Set	TIME		○
Track Mode Set	CHAPTER	○	○
Frame Mode Set	FRAME		○
Play	PLAY ►	○	○
(Reject)	REJECT ▲		○
(Pause)	PAUSE ■	○	○
(Search)	SEARCH	Track Search	○
(Scan Forward)	SCAN ►►		○
(Scan Reverse)	SCAN ◄◄		○
(1 Track Search Forward)	STILL / STEP ►►	○	○
(1 Track Search Reverse)	STILL / STEP ◄◄	○	○
(Eject)	OPEN (FUNC + 9)	○	○
(Speed)	SPEED (FUNC + 8)		○
(X Speed)	A (FUNC + FRAME)		○
(Test / Normal Mode Change)	C-MODE (FUNC + 3)		○
(Servo All OFF)	0 + TIME		○
(Focus ON)	1 + TIME		○
(Spindle Kick, Tracking ON / OFF)	2 + TIME		○
(Tracking OFF)	3 + TIME		○
(Slide FWD)	4 + TIME		○
(Slide REV)	5 + TIME		○
(Search TR No. 2)	6 + TIME		○

• **Specification method of the player issuing the command**

One remote control unit is prepared for two players in this unit.

It is necessary to specify the player beforehand when issues the command to each player.

Specification method of player A (left side from the front): Press buttons of "1", "STOP.M" ("FUNC" and "5") in order.

Specification method of player B (right side from the front): Press buttons of "2", "STOP.M" ("FUNC" and "5") in order.

Command is published by the specified player till the next Player Select command is issued after this command issue.

## CMX-3000, CU-V163

### • Specification method of addressing modes in the search

There are three ways of search methods of time search, track search and frame search in this unit. It is necessary to specify each mode when performs each search.

#### • Time search (A Time mode set)

Set absolute time (minute, second, frame) in the address mode.

[Examples] When search for 2 minutes 34 seconds 56 frame:

Press buttons of "TIME", "0", "2", "3", "4", "5", "6" and "SEARCH" in order.

#### • Track search (Track mode set)

Set track number in the address mode.

[Examples] When search for track 5:

Press buttons of "CHAPTER", "5" and "SEARCH" in order.

#### • Frame search (Frame mode set)

Set frame in the address mode.

[Examples] When search for 1200 frame:

Press buttons of "1", "2", "0", "0" and "SEARCH" in order.

### • Player operation command

(Play) : Playback

(Reject) : Stop

(Pause) : Pause. Also stop the scan operation during scan, and become pause.  
Become the sound output pause in the CDJ mode.

(Scan Forward) : Perform the scan operation in the forward direction.  
Press the PAUSE button when completes the scan operation.

(Scan Reverse) : Perform the scan operation in the reverse direction.  
Press the PAUSE button when completes the scan operation.

(1 Track Search Forward) : Perform the track search in the forward direction.

(1 Track Search Reverse) : Perform the track search in the reverse direction.

(Eject) : Perform the disc eject either Playback state or Stop state.

(Speed) : In the CDJ mode, set the playback speed (tempo) that specified with the argument.

An argument is three columns of figure and specify 0: - (minus) or 1: + (plus) with 100-place.

And specify (from 0 to 16) a tempo (%) by two places of remainders.

Example: It becomes the +1% setting by pressing buttons of "1", "0", "1", "SPEED" ("FUNC" and "8") in order.

It becomes the -10% setting by pressing buttons of "0", "1", "0", "SPEED" ("FUNC" and "8") in order.

It becomes the +16% setting by pressing buttons of "1", "1", "6", "SPEED" ("FUNC" and "8") in order.

• **Test operation command**

As for the following command, an operation becomes possible in the digital mode (digital mode switch of front panel is ON). Because there is a case to damage the player when test operation command mistakes usage, be careful.

(X Speed) : In the digital mode, switch the rotation speed of the player to normal speed and double speed .  
Further, sound cannot output in the double speed.

Example:

It becomes the normal speed playback setting by pressing buttons of "1" and "A" ("FUNC" and "FRAME") in order.

It becomes the double speed playback setting by pressing buttons of "2" and "A" ("FUNC" and "FRAME") in order.

\* This command issues a command by stopped state in order to issue a command to servo DSP directly.

(Test/Normal Mode Change) : Switch the Test mode/Normal mode by "C-MODE" ("FUNC" and "3") buttons.  
Can use only commands of 6TM from 0TM in the test mode.

(Servo All OFF) : During servo ON, turn all servo OFF when pressing "0" and "TIME" buttons in order.

(Focus ON) : During CD STOP, turn the LD ON and perform the auto focus when pressing "1" and "TIME" buttons in order.

(Spindle Kick and Tracking ON/OFF) : During tracking servo OFF, perform the spindle kick and turn the automatic adjustment processing and tracking servo ON when pressing "2" and "TIME" buttons in order.  
Also during tracking servo ON, turn the tracking servo OFF when pressing "2" and "TIME" buttons in order.

(Tracking OFF) : During tracking servo ON, turn the tracking servo OFF when pressing "3" and "TIME" buttons in order.

(Slide FWD) : During tracking servo ON, Turn the tracking servo OFF and move the slider in the FWD direction when pressing "4" and "TIME" buttons in order.

(Slide REV) : Turn the tracking servo OFF and move the slider in the REV direction when pressing "5" and "TIME" buttons in order during tracking servo ON.

(SEARCH TR No. 2) : During CD STOP, perform the following operation when pressing "6" and "TIME" buttons in order.  
LD ON - Auto focus - Spindle kick - automatic adjustment processing - Second tune search - Tracking servo ON  
When performed Tracking OFF, there is the case that cannot rise up in this command.  
In that case please repeat once again after power OFF and ON.

\* : When rise up by a step with the test mode, input a command by pressing buttons of "0", "TIME", "1", "TIME", "2" and "TIME" in order.

■ **State Confirmation Mode in the System Operation**

The mode which confirms confirmation and operating state of software version of each microcomputer by display.

• **Confirmation method of the microcomputer software version of the controller section**

Load two microcomputers on the controller section.

As for the symptom of a version of each microcomputer, dot matrix is displayed for about 2 seconds while pressing each PITCH BEND (+) button by turning the power on.

• **Confirmation method of the player section**

Player section processes both players with one microcomputer.

As for the method to confirm a microcomputer version, a version is displayed by long push of CD TEXT/WAVE button and OUT/OUT ADJ button in FL.

# CMX-3000, CU-V163

## 7.1.2 STARTING SEQUENCE

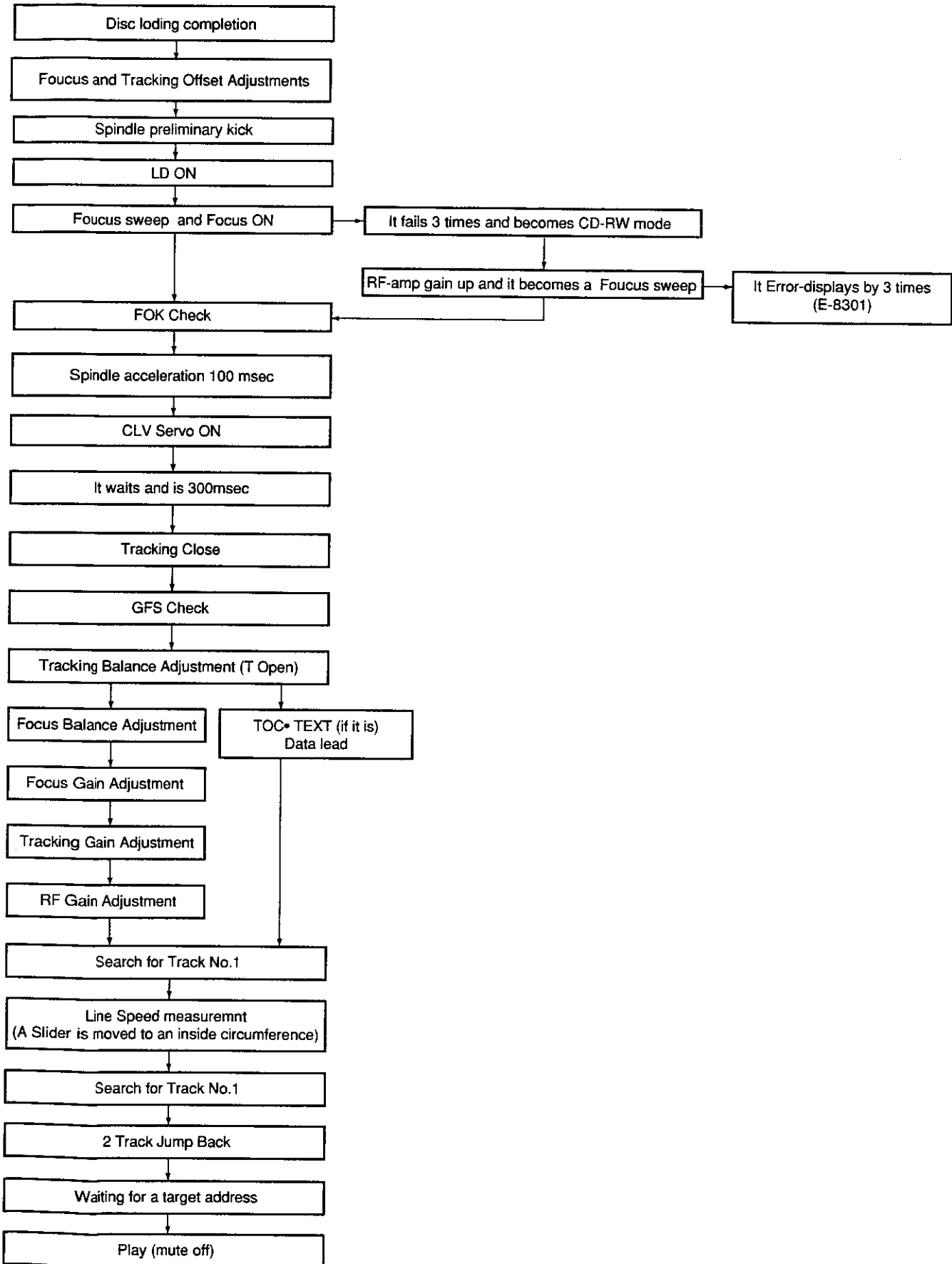

7.1.3 DISASSEMBLY

(1) CMX-3000

■ Bonnet

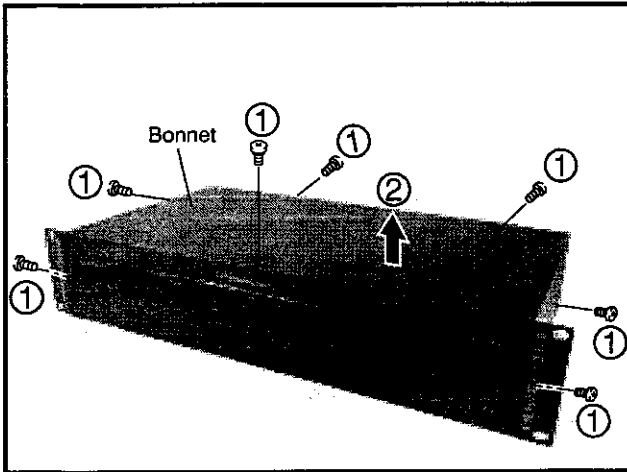

■ MAIN Assy - Player Section

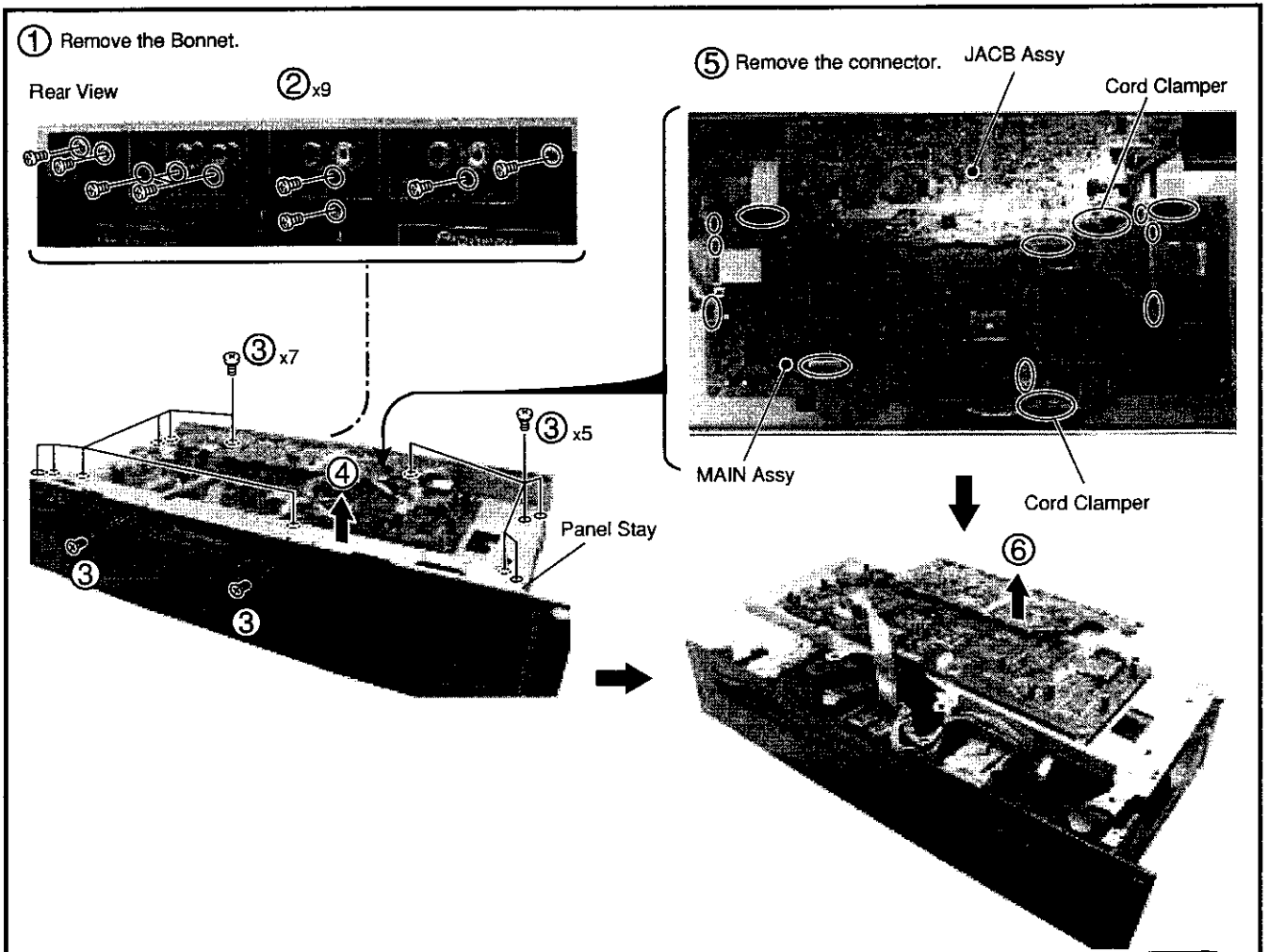

■ Front panel Section

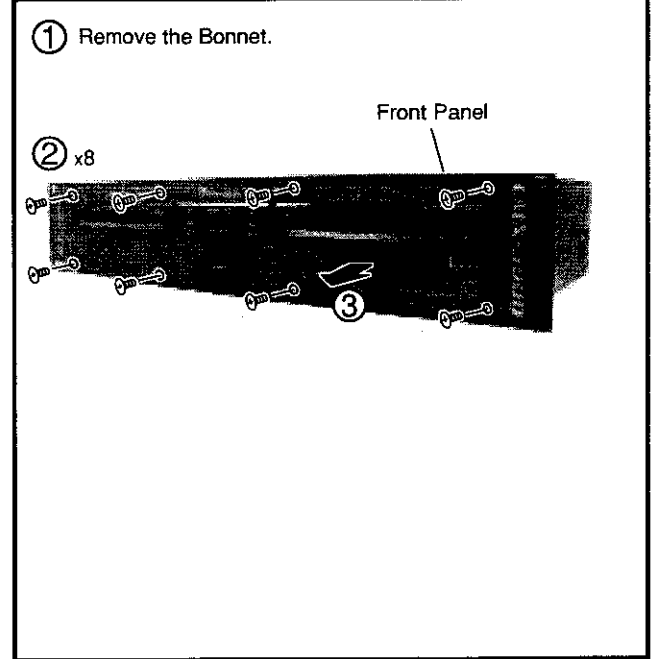



■ SLOT-IN MECHANISM Assy

A PLAYER

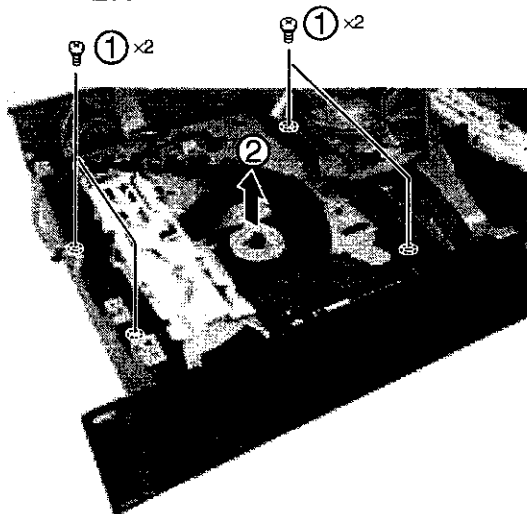

B PLAYER

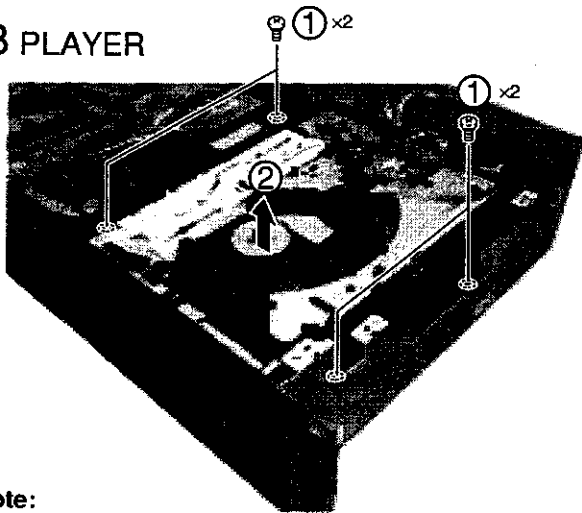

**Note:**  
 Servo Mechanism Assy can diagnose and remove it from the backside.  
 (Inverts the product, and not performing the operation check.)

■ SERVO MECHANISM Assy

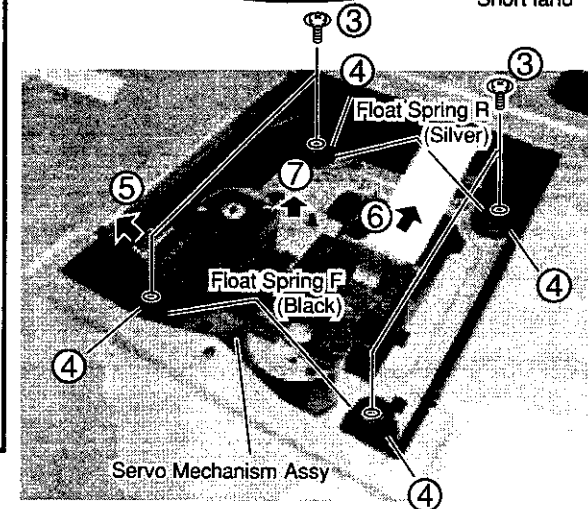
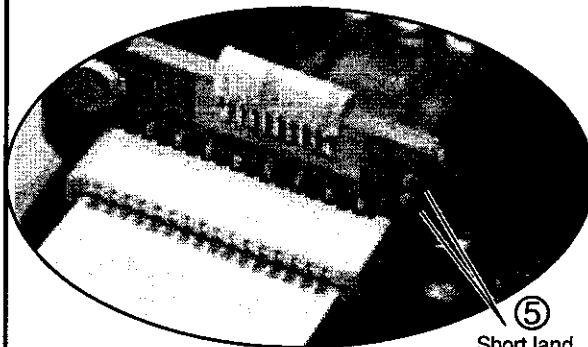
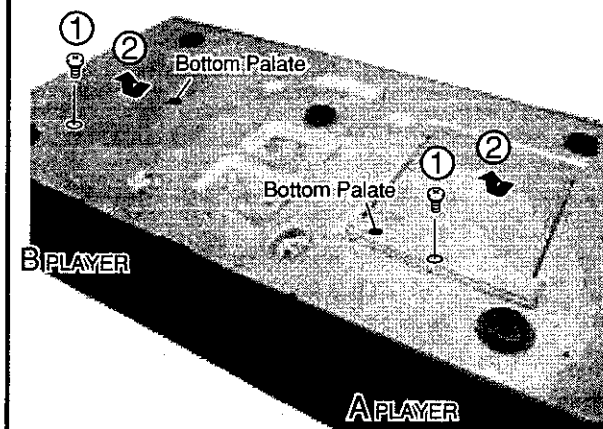

[Caution in the Servo Mechanism Assy replacement]

- When remove the Servo Mechanism Assy, short-circuit a LD Short land ⑤ before disconnecting a flexible cable from the connector.  
 When install the Servo Mechanism Assy, release the short-circuit of LD Short land ⑤ after connecting the flexible cable to the connector. (For LD fracture prevention)
- Installing the Froat Spring F and Froat Spring R to the correct position.  
 Front side : Froat Spring F (Black) x2  
 Rear side : Froat Spring R (Silver) x2



■ The Operation check method of a mechanism unit

① Remove the Bonnet

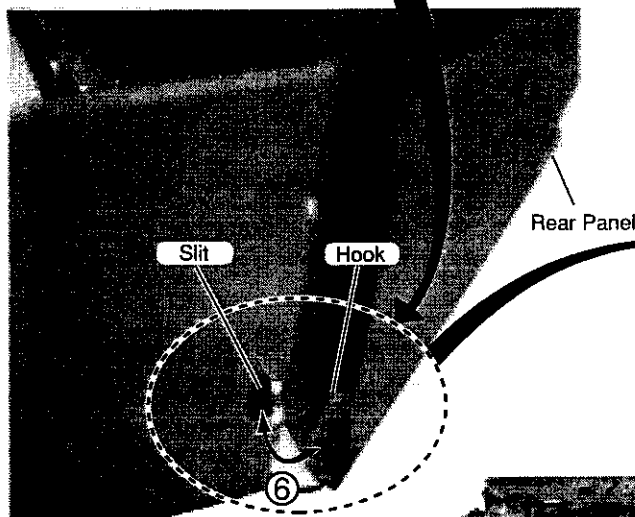
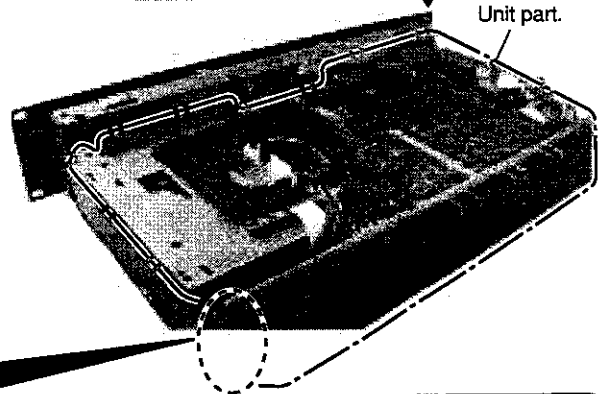
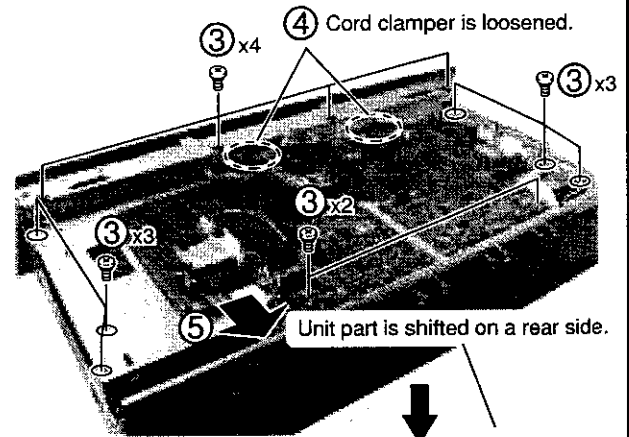
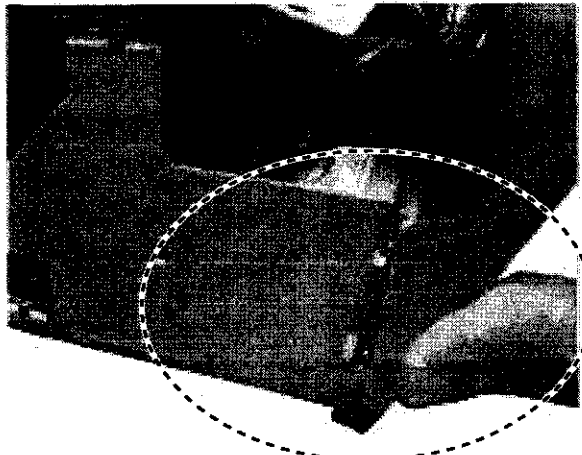
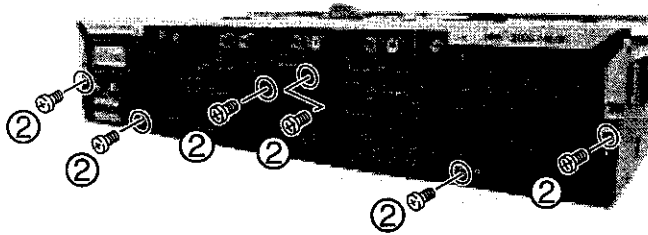

The Hook of a rear panel is put in to a slit.

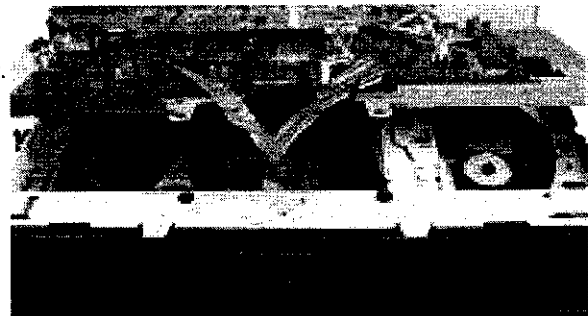
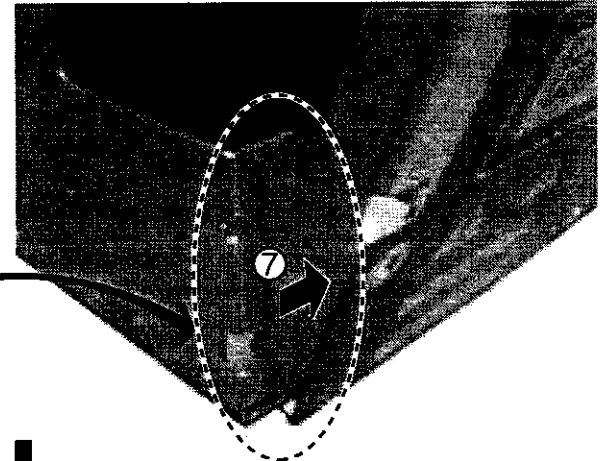

⑧ Diagnosis of a mechanism unit.

(2) REMOTE CONTROLLER (CU-V163)

■ Rear Panel

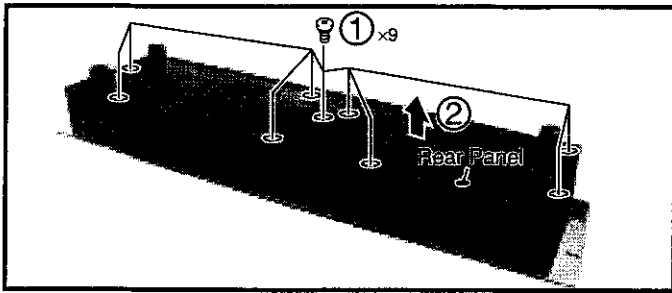

■ CNTA, CNTB Assy

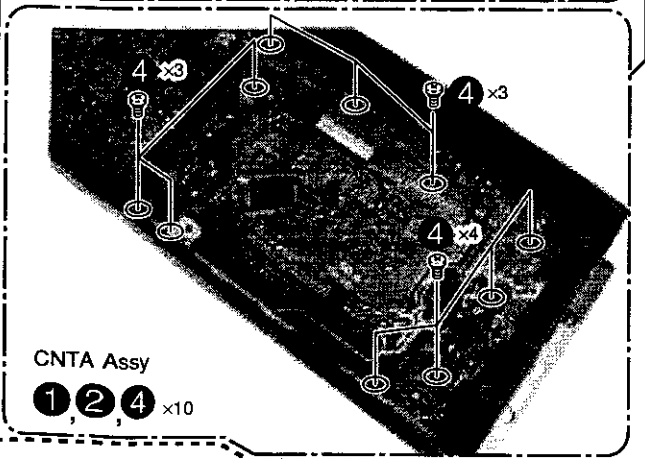
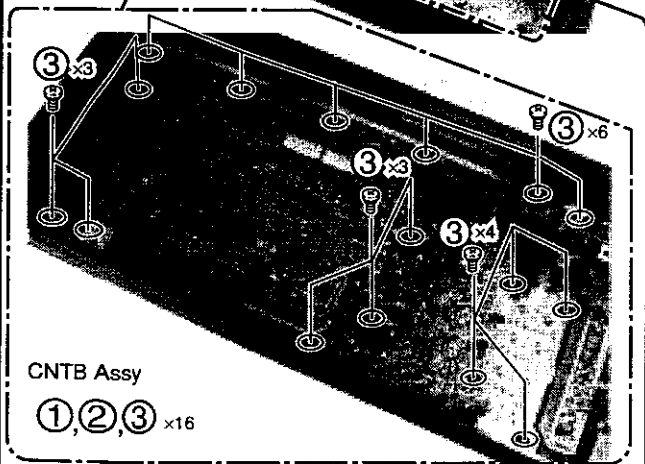
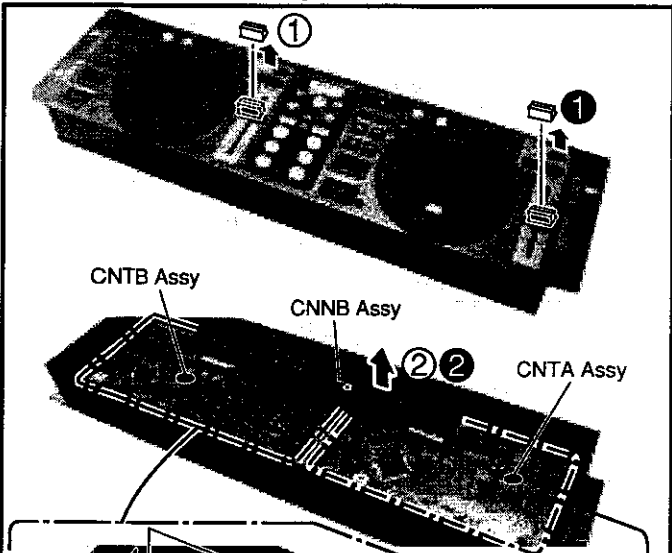

Note :

When cuts PC Board with a nipper and replaced slide VR, positioning becomes invalid. Please aline it by visual inspection when installs it. (Refer to the following diagram.)

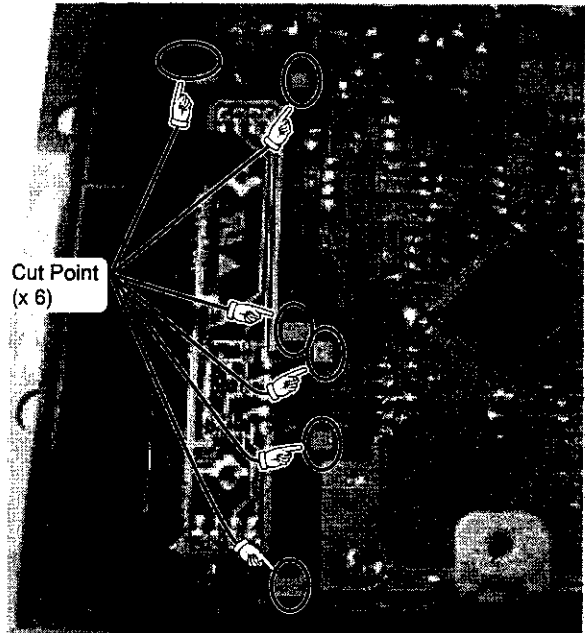

This illustration is CNTB Assy.

■ JOG Dial

① Remove the CNTA, CNTB and CNNB Assy

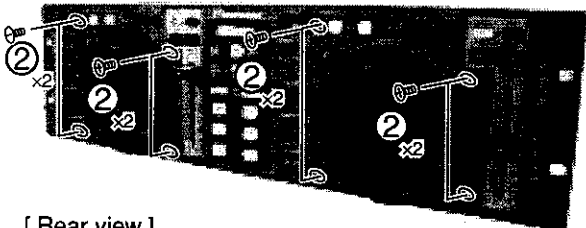

[ Rear view ]

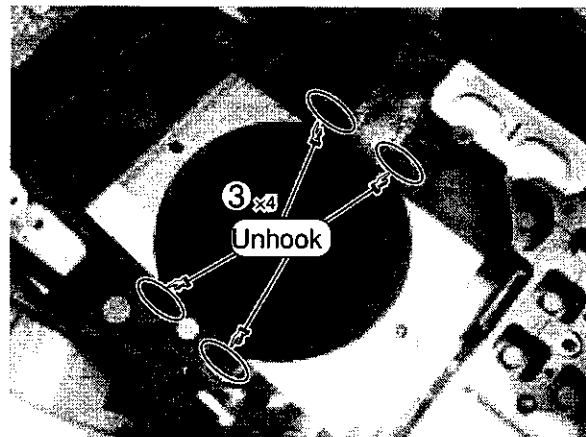

④ Remove the Front Panel Assy

■ JOG Dial Section

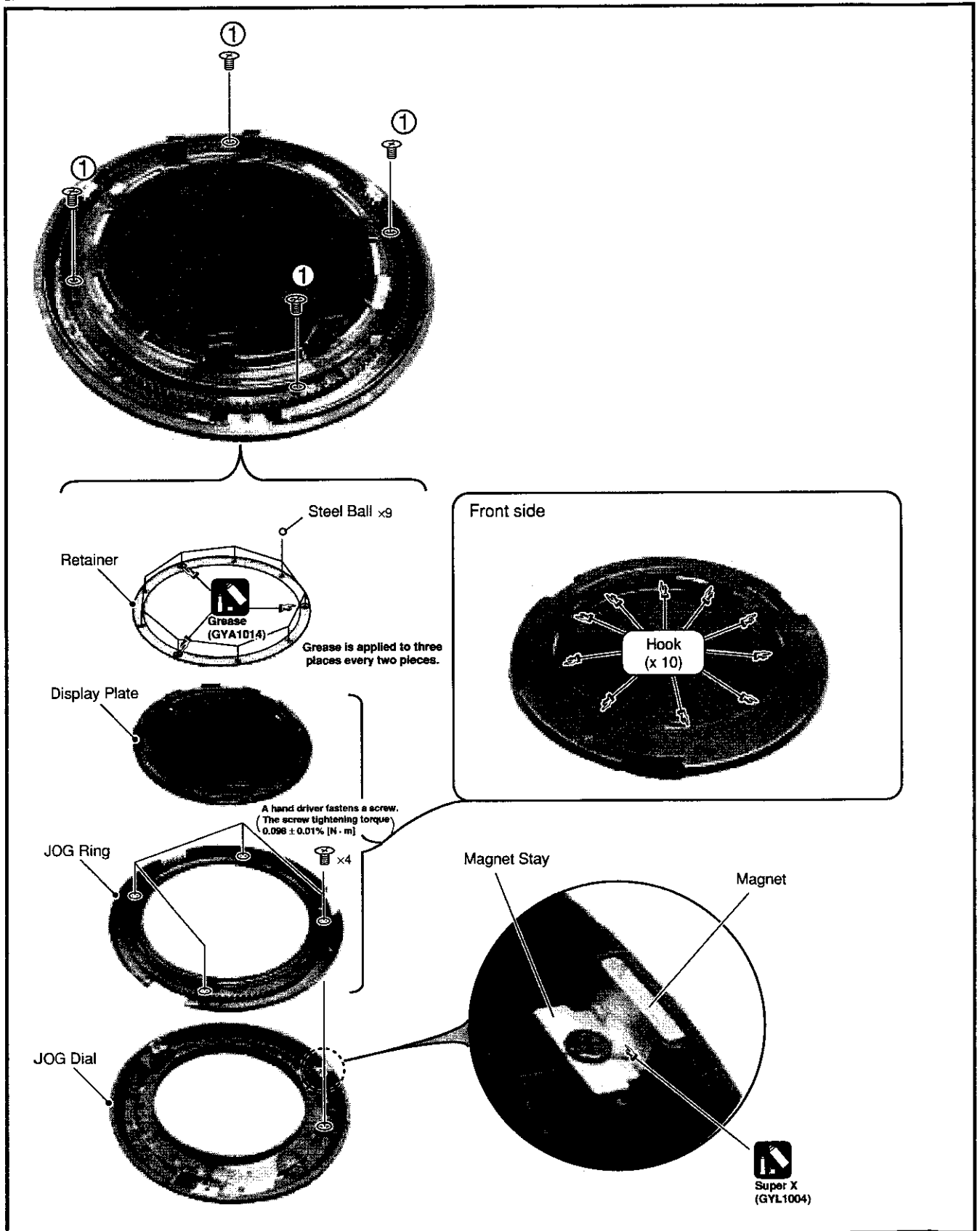

# CMX-3000, CU-V163

## 7.2 PARTS

### 7.2.1 IC

• The information shown in the list is basic information and may not correspond exactly to that shown in the schematic diagrams.

#### • List of IC

NJM2870F18, NJM2870F25, NJM2360M, PST994D, TC74VHC04FT, XC2S30-5TQ144C, TA2153FN, PD5764A, HD6417709AF100B

#### ■ NJM2870F18 (MAIN ASSY : IC1406)

##### • Regulator IC

##### ● Pin Arrangement

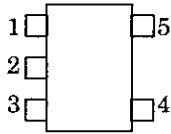

- PIN FUNCTION**
- 1. CONTROL (Active High)
  - 2. GND
  - 3. NOISE BYPASS
  - 4.  $V_{OUT}$
  - 5.  $V_{IN}$

##### ● Block Diagram

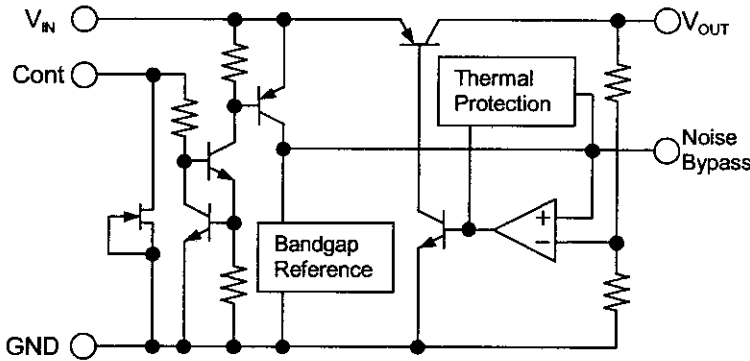

#### ■ NJM2870F25 (MAIN ASSY : IC1009)

##### • Regulator IC

##### ● Pin Arrangement

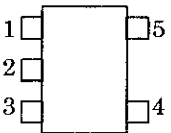

- PIN FUNCTION**
- 1. CONTROL (Active High)
  - 2. GND
  - 3. NOISE BYPASS
  - 4.  $V_{OUT}$
  - 5.  $V_{IN}$

##### ● Block Diagram

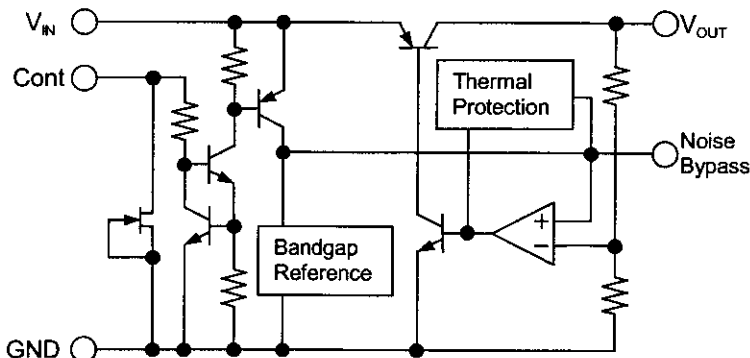

■ NJM2360M (JACB ASSY : IC211)

• DC-DC Convertor

● Pin Arrangement

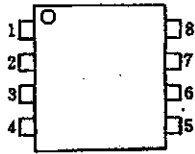

PIN FUNCTION

- 1.  $C_s$
- 2.  $E_s$
- 3.  $C_T$
- 4. GND
- 5.  $INV_{IN}$
- 6.  $V^+$
- 7.  $S_I$
- 8.  $C_D$

● Block Diagram

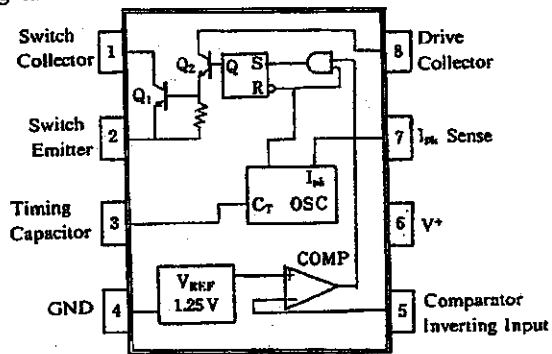

■ PST994D (CNTB ASSY : IC502)

• Reset IC

● Block Diagram

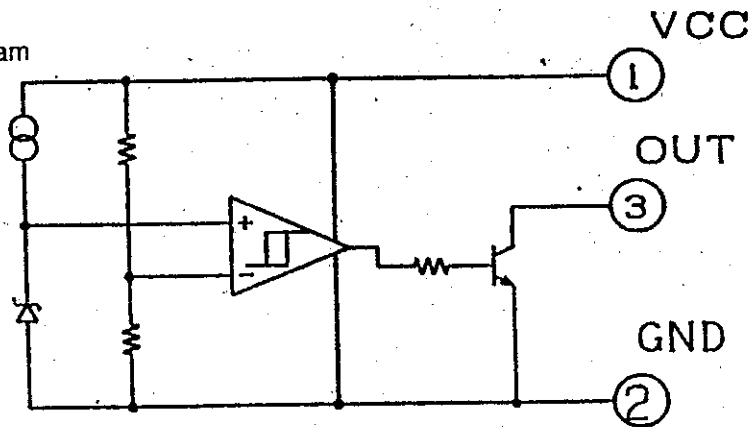

■ TC74VHC04FT (MAIN ASSY : IC1437)

• Logic IC

● Pin Arrangement

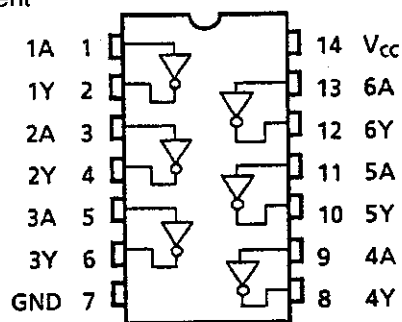

(TOP VIEW)

# CMX-3000, CU-V163

## ■ XC2S30-5TQ144C (MAIN ASSY : IC1409)

• PLD IC

● Pin Name

Pin No.	Port Name	Pin Name	Pin No.	Port Name	Pin Name	Pin No.	Port Name	Pin Name
1	Vcco	Vcco	51	D6	I/O,IRDY	101	NC	I/O
2	TCK	TCK	52	GND	GND	102	XCS5	I/O,Vref
3	EX_CONT2_A	I/O	53	VCCO	VCCO	103	XCS2	I/O
4	DAC1_MCLK	I/O	54	D7	I/O,Trdy	104	STATUS	STATUS
5	DAC1_BCK	I/O,Vref	55	Vccint	Vccint	105	PWDN	PWDN
6	DAC1_LRCK	I/O	56	A1	I/O	106	M2	M2
7	DAC1_DATA	I/O	57	A2	I/O(D4)	107	VCCO	Vcco
8	GND	GND	58	MREQB	I/O,Vref	108	VCCO	Vcco
9	Vccint	Vccint	59	XRD	I/O	109	M0	M0
10	DAC2_MCLK	I/O	60	XWE	I/O(D5)	110	GND	GND
11	DAC2_BCK	I/O	61	GND	GND	111	M1	M1
12	DAC2_LRCK	I/O,Vref	62	MREQA	I/O(D6)	112	A25	I/O
13	DAC2_DATA	I/O	63	BCLKA	I/O	113	A24	I/O
14	Vccint	Vccint	64		I/O	114	A23	I/O
15	CKIO	GCK3	65	DSP1BCK	I/O,Vref	115	A3	I/O,Vref
16	VCCO	Vcco	66	DBCLKA	I/O	116	NC	I/O
17	GND	GND	67	DSP1LRCK	I/O(D7)	117	D8	I/O
18	PLLCLK	GCK2	68	INIT	I/O(INIT)	118	D9	I/O
19	GND	I/O	69	XPROGRAM	PROGRAM	119	GND	GND
20	EX_CONT1B	I/O	70	Vcco	Vcco	120	D10	I/O
21	EX_CONT2B	I/O,Vref	71	Vcco	Vcco	121	D11	I/O
22	SBOK2	I/O	72	DONE	DONE	122	D12	I/O,Vref
23	SUBQ2	I/O	73	GND	GND	123	D13	I/O
24	Vccint	Vccint	74	SDI0A	I/O	124	D14	I/O
25	GND	GND	75	SDI1A	I/O	125	Vccint	Vccint
26	SBSY2	I/O	76	SDI2A	I/O	126	D15	I/O,TRDY
27		I/O	77	SDI2B	I/O,Vref	127	Vcco	Vcco
28	SFSY2	I/O,Vref	78	DSP2DATA	I/O	128	GND	GND
29	LRCK2	I/O	79	DSP1DATA	I/O	129	RD/XWR	I/O,IRDY
30	BCK2	I/O(WRITE)	80	SDI1B	I/O	130	XDREQ1	I/O
31	ADATA2	I/O(CS)	81	GND	GND	131	XDREQ0	I/O
32	TDI	TDI	82	Vccint	Vccint	132	SUBQ1	I/O,Vref
33	GND	GND	83	DISC_LED_A	I/O	133	SBSY1	I/O
34	TDO	TDO	84	DISC_LED_B	I/O	134		I/O
35	Vcco	Vcco	85	G2	I/O,Vref	135	GND	GND
36	Vcco	Vcco	86	A2	I/O	136	SBOK1	I/O
37	CCLK	CCLK	87	GND	I/O	137	SFSY1	I/O
38		I/O(DOUT,BUSY)	88	ACLK2	GCK0	138	ADATA1	I/O
39	DIN	I/O(DIN,D0)	89	GND	GND	139	LRCK1	I/O,Vref
40	BCLKB	I/O	90	Vcco	Vcco	140	BCK1	I/O
41	DBCLKB	I/O,Vref	91	ACLK1	GCK1	141	EX_CONT1_A	I/O
42		I/O	92	Vccint	Vccint	142	TMS	TMS
43	SDI0B	I/O	93	G1	I/O	143	GND	GND
44	D0	I/O(D1)	94	A1	I/O,Vref	144	VCCO	VCCO
45	GND	GND	95		I/O			
46	D1	I/O(D2)	96	XDACK1	I/O			
47	D2	I/O	97	Vccint	Vccint			
48	D3	I/O,Vref	98	GND	GND			
49	D4	I/O(D3)	99	XDACK0	I/O			
50	D5	I/O	100	XRST	I/O			

● Pin Function (1/2)

PLL

Pin No.	Pin Name	I/O	Description	Connection Point
18	PLLCK	I	16.9344MHz Standard Frequency Input	Standard Frequency area
91	ACLK1	I	VCO input for CD1	VCO area
93	G1	O	Phase comparison machine output for CD1	VCO area
94	A1	O	Phase comparison machine output for CD1	VCO area
88	ACLK2	I	VCO input for CD2	VCO area
85	G2	O	PLL output for CD2	VCO area
86	A2	O	PLL output for CD2	VCO area

DSP I/F

Pin No.	Pin Name	I/O	Description	Connection Point
62	MREQA	I	Ach REQ signal CD1	DSP Ach
63	BCLKA	O	Bit clock output terminal, clock for audio data	DSP Ach
66	DBCLKA	O	Word clock output terminal	DSP Ach
74	SDI0A	O	Serial audio data output terminal 0	DSP Ach
75	SDI1A	O	Serial audio data output terminal 1	DSP Ach
76	DSI2A	O	Data lead	DSP Ach
58	MREQB	I	Bch REQ signal CD2	DSP Ach
40	BCLKB	O	bit clock output terminal, clock for audio data	DSP Ach
41	DBCLKB	O	Word clock output terminal	DSP Ach
43	SDI0B	O	Serial audio data output terminal 0	DSP Ach
80	SDI1B	O	Serial audio data output terminal 1	DSP Ach
77	DSI2B	O	Data lead	DSP Ach

AUDIO INPUT I/F

Pin No.	Pin Name	I/O	Description	Connection Point
140	BCK1	I	bit clock for audio input from CD1	D Servo IC1
139	LRCK1	I	LR clock for audio input from CD1	D Servo IC1
138	ADATA1	I	audio data from CD1	D Servo IC1
133	SBSY1	I	sub code sync. from CD1	D Servo IC1
137	SFSY1	I	frame sync. from CD1	D Servo IC1
132	SUBQ1	I	sub code Q data from CD1	D Servo IC1
136	S BOK1	I	sub code Q data CRCC judging result input terminal from CD1	D Servo IC1
30	BCK2	I	bit clock for audio input from CD2	D Servo IC2
29	LRCK2	I	R clock for audio input from CD2	D Servo IC2
31	ADATA2	I	audio data from CD2	D Servo IC2
26	SBSY2	I	sub code sync. from CD2	D Servo IC2
28	SFSY2	I	frame sync. from CD2	D Servo IC2
23	SUBQ2	I	sub code Q data from CD2	D Servo IC2
22	S BOK2	I	sub code Q data CRCC judging result input terminal from CD2	D Servo IC2

AUDIO DATA CHANGE

Pin No.	Pin Name	I/O	Description	Connection Point
65	DSP1BCK	I	audio data is changed	DSP
67	DSP1LRCK	I	audio data is changed	DSP
79	DSP1DATA	I	audio data is changed	DSP
78	DSP2DATA	I	audio data is changed	DSP

DAC I/F

Pin No.	Pin Name	I/O	Description	Connection Point
4	DAC1_MCLK	O	clock for DAC1	DAC1
5	DAC1_BCK	O	bit clock for DAC1	DAC1
6	DAC1_LRCK	O	LR clock for DAC1	DAC1
7	DAC1_DATA	O	data for DAC1	DAC1
10	DAC2_MCLK	O	data for DAC2	DAC2
11	DAC2_BCK	O	bit clock for DAC2	DAC2
12	DAC2_LRCK	O	LR clock for DAC2	DAC2
13	DAC2_DATA	O	data for DAC2	DAC2

# CMX-3000, CU-V163

## ● Pin Function (2/2)

### CPU I/F

Pin No.	Pin Name	I/O	Description	Connection Point
102	XCS5	I	CH input for address decoding	SH3
103	XCS2	I	CH input for address decoding	SH3
112	A25	I	CH input for address decoding	SH3
113	A24	I	CH input for address decoding	SH3
114	A23	I	CH input for address decoding	SH3
115	A3	I	address input terminal for CPU	SH3
57	A2	I	address input terminal for CPU	SH3
56	A1	I	address input terminal for CPU	SH3
128	D15	I/O	address input terminal for CPU	SH3
124	D14	I/O	address input terminal for CPU	SH3
123	D13	I/O	address input terminal for CPU	SH3
122	D12	I/O	address input terminal for CPU	SH3
121	D11	I/O	address input terminal for CPU	SH3
120	D10	I/O	address input terminal for CPU	SH3
118	D9	I/O	address input terminal for CPU	SH3
117	D8	I/O	address input terminal for CPU	SH3
54	D7	I/O	address input terminal for CPU	SH3
51	D6	I/O	address input terminal for CPU	SH3
50	D5	I/O	address input terminal for CPU	SH3
49	D4	I/O	address input terminal for CPU	SH3
48	D3	I/O	address input terminal for CPU	SH3
47	D2	I/O	address input terminal for CPU	SH3
46	D1	I/O	address input terminal for CPU	SH3
44	D0	I/O	address input terminal for CPU	SH3
130	XDREQ1	O	data request	SH3
131	XDREQ0	O	data request	SH3
96	XDACK1	I	data acknowledge	SH3
99	XDACK0	I	data acknowledge	SH3
60	XWE	I	write enable signal	SH3
59	XRD	I	read strobe signal	SH3
129	RD/XWR	I	read write signal	SH3
15	CKIO	I	system clock	SH3
100	XRST	I	system reset	SH3

### CPU I/O EXTENSION

Pin No.	Pin Name	I/O	Description	Connection Point
141	EX_CONT1_A	I/O		
3	EX_CONT2_A	I		
20	EX_CONT1B	I/O		
21	EX_CONT2B	I		
83	DISC_LED_A	O		
84	DISC_LED_B	O		

### CONFIGURATION

Pin No.	Pin Name	I/O	Description
109	M0	I	
111	M1	I	
106	M2	I	
69	XPROGRAM	O	
39	DIN	I	
68	XINIT	O	
37	CCLK	I/O	
72	DONE	O	

### OTHERS

Pin No.	Pin Name	I/O	Description
9, 14, 24, 55 82, 92, 97, 125	Vccint		2.5V
1, 35, 36, 53, 70 71, 90, 107, 108 127, 144	Vccco		3.3V
8, 17, 19, 25, 33 45, 52, 61, 73, 81 87, 98, 110, 135 143	GND		GND



■ TA2153FN (MAIN ASSY : IC1003, IC1010)

• RF Amp IC

● Block Diagram

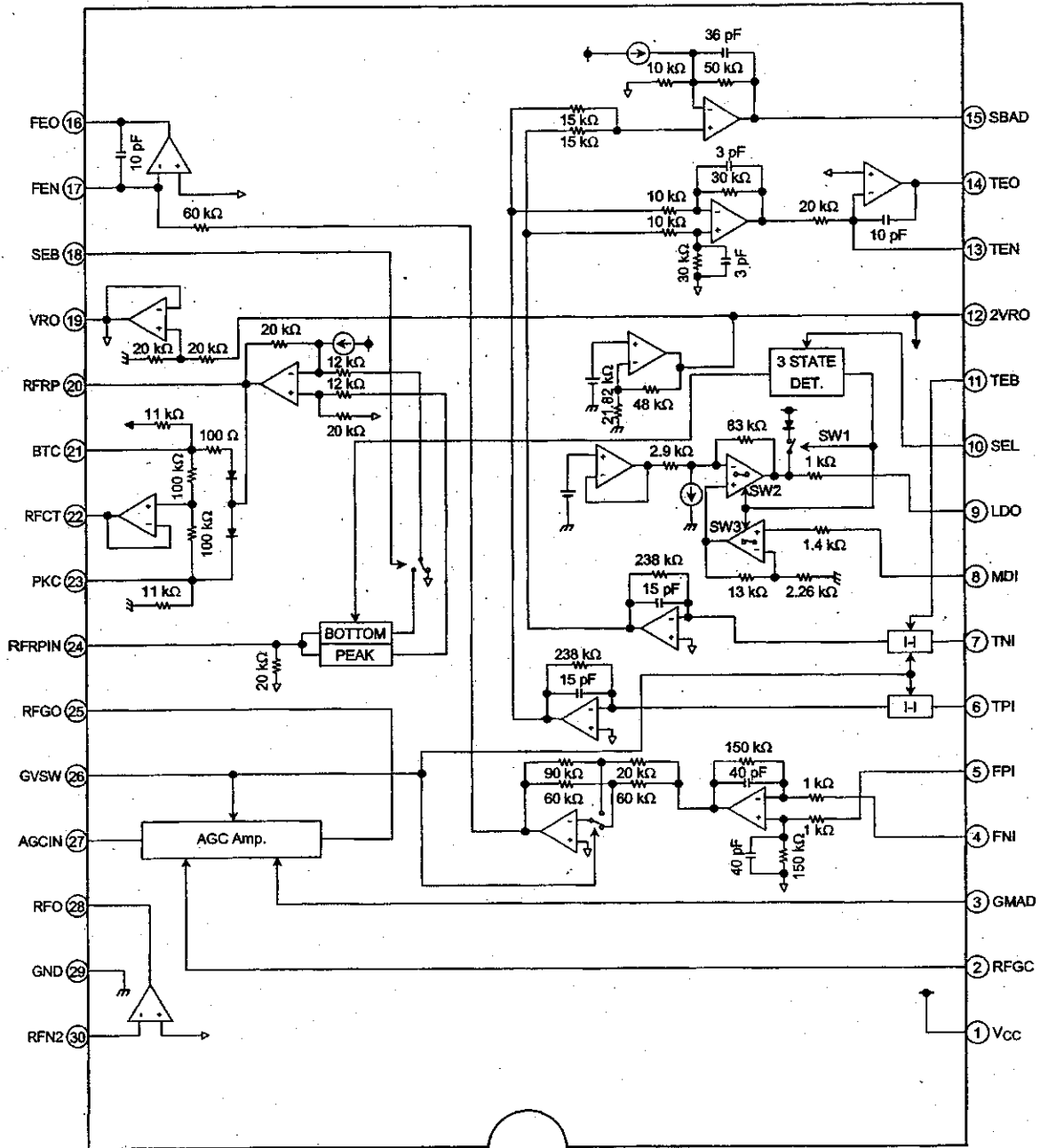

# CMX-3000, CU-V163

## ● Pin Function (1/2)

Pin No.	Symbol	I/O	Function Description	Remarks																
1	V <sub>CC</sub>	—	Power supply input terminal.	—																
2	RFGC	I	RF amplitude adjustment control signal input terminal. Controlled by 3-PWM signals. (PWM carrier = 88.2 kHz)	3 signals input. (2VRO, VRO, GND)																
3	GMAD	I	Open loop gain adjustment terminal for AGC amp.	(Note1)																
4	FNI	I	Main beam I-V amp input terminal.	Connected to pin diode output B + D (through resistor).																
5	FPI	I	Main beam I-V amp input terminal.	Connected to pin diode output A + C (through resistor).																
6	TPI	I	Sub beam I-V amp input terminal.	Connected to pin diode output F.																
7	TNI	I	Sub beam I-V amp input terminal.	Connected to pin diode output E.																
8	MDI	I	Monitor photo diode amp input terminal.	Connected to monitor photo diode.																
9	LDO	O	Laser diode amp input terminal.	Connected to laser diode control circuit.																
10	SEL	I	Laser diode control signal input terminal and APC circuit ON/OFF control signal terminal. <table border="1" style="margin: 10px auto;"> <thead> <tr> <th>SEL Level</th> <th>APC Circuit</th> <th>LDO</th> <th>Detect Frequency</th> </tr> </thead> <tbody> <tr> <td>GND</td> <td>OFF</td> <td>Connected to V<sub>CC</sub> through resistor (1 kΩ)</td> <td>Low</td> </tr> <tr> <td>HIZ</td> <td>ON</td> <td>Control signal output</td> <td>Low</td> </tr> <tr> <td>V<sub>CC</sub></td> <td>ON</td> <td>Control signal output</td> <td>High</td> </tr> </tbody> </table>	SEL Level	APC Circuit	LDO	Detect Frequency	GND	OFF	Connected to V <sub>CC</sub> through resistor (1 kΩ)	Low	HIZ	ON	Control signal output	Low	V <sub>CC</sub>	ON	Control signal output	High	3 signals input. (V <sub>CC</sub> , HIZ, GND)
SEL Level	APC Circuit	LDO	Detect Frequency																	
GND	OFF	Connected to V <sub>CC</sub> through resistor (1 kΩ)	Low																	
HIZ	ON	Control signal output	Low																	
V <sub>CC</sub>	ON	Control signal output	High																	
11	TEB	I	Tracking error balance adjustment signal input terminal. Controlled by 3-PWM signal. (PWM carrier = 88.2 kHz)	3 signals input. (2VRO, VRO, GND)																
12	2VRO	O	Reference voltage (2VRO) output terminal. 2VRO = 4.2 V when V <sub>CC</sub> = 5 V	—																
13	TEN	I	TE amp negative input terminal.	Connected to TEO through feedback resistor.																
14	TEO	O	TE error signal output terminal.	—																
15	SBAD	O	Sub beam adder signal output terminal.	—																
16	FEO	O	Focus error signal output terminal.	—																
17	FEN	I	FE amp negative input terminal.	Connected to FEO through feedback resistor.																
18	SEB	I	RFRP output circuit switching terminal. <table border="1" style="margin: 10px auto;"> <thead> <tr> <th>SEB Level</th> <th>Bottom Detection</th> <th>Peak Detection</th> </tr> </thead> <tbody> <tr> <td>GND</td> <td>ON</td> <td>ON</td> </tr> <tr> <td>V<sub>CC</sub></td> <td>OFF</td> <td>ON</td> </tr> </tbody> </table>	SEB Level	Bottom Detection	Peak Detection	GND	ON	ON	V <sub>CC</sub>	OFF	ON	Low (GND) is for normal use.							
SEB Level	Bottom Detection	Peak Detection																		
GND	ON	ON																		
V <sub>CC</sub>	OFF	ON																		
19	VRO	O	Reference signal (VRO) output terminal. VRO = 2.1 V when V <sub>CC</sub> = 5 V	—																
20	RFRP	O	Track count signal output terminal.	—																
21	BTC	I	Time constant adjustment terminal for bottom detection.	Adjusted by capacitance.																

● Pin Function (2/2)

Pin No.	Symbol	I/O	Function Description	Remarks								
22	RFCT	O	RFRP signal center level output terminal.	—								
23	PKC	I	Time constant adjustment terminal for peak detection.	Adjusted by capacitance.								
24	RFRPIN	I	Input terminal for track count signal output amp.	—								
25	RFGO	O	Output terminal for RF signal amplitude adjustment amp.	—								
26	GVSW	I	Amp (AGC, FE, TE) gain switching terminal. <table border="1" style="margin: 10px auto;"> <thead> <tr> <th>GVSW</th> <th>Mode</th> </tr> </thead> <tbody> <tr> <td>GND</td> <td>CD-RW</td> </tr> <tr> <td>HIZ</td> <td>Normal</td> </tr> <tr> <td>VCC</td> <td>Normal</td> </tr> </tbody> </table>	GVSW	Mode	GND	CD-RW	HIZ	Normal	VCC	Normal	Low (GND) is for 5 times gain.
GVSW	Mode											
GND	CD-RW											
HIZ	Normal											
VCC	Normal											
27	AGCIN	I	Input terminal for RF signal amplitude adjustment amp.	Connected to RFO through capacitance.								
28	RFO	O	Output terminal RF signal amp.	—								
29	GND	—	Ground terminal.	—								
30	RFN2	I	Input terminal for RF signal amp.	Connected to pin-diode output A + B + C + D (through resistor).								

Note1: Pin3 (GMAD) is gm adjustment terminal for AGC amp by applying a voltage (between 1.5 V and 4.2 V).  
 If pin3 (GMAD) is open, voltage of this terminal is fixed VR by IC interior.  
 Characteristic of frequency (open-loop characteristic) and voltage is as below.

# CMX-3000, CU-V163

## ■ PD5764A (CNTB ASSY : IC501)

• Micro computer (Master CPU)

● Pin Function

Pin No	Pin Name	I/O	Discription	Pin No	Pin Name	I/O	Discription
1	KEY5	I	Key Input	51	S22	O	FL Disply Segment 1: Light up
2	KEY4	I	Key Input	52	S21	O	FL Disply Segment 1: Light up
3	KEY3	I	Key Input	53	S20	O	FL Disply Segment 1: Light up
4	KEY2	I	Key Input	54	S19	O	FL Disply Segment 1: Light up
5	KEY1	I	Key Input	55	S18	O	FL Disply Segment 1: Light up
6	KEY0	I	Key Input	56	S17	O	FL Disply Segment 1: Light up
7	LED7	O	BPM SYNC 1: Light up	57	S16	O	FL Disply Segment 1: Light up
8	LED6	O	RELAY PLAY 1: Light up	58	S15	O	FL Disply Segment 1: Light up
9	NC	O	-	59	S14	O	FL Disply Segment 1: Light up
10	LED4	O	PLAY/ PAUSE 1: Light up	60	S13	O	FL Disply Segment 1: Light up
11	LED3	O	CUE 1: Light up	61	S12	O	FL Disply Segment 1: Light up
12	LED2	O	IN/ REALTIME CUE 1: Light up	62	S11	O	FL Disply Segment 1: Light up
13	LED1	O	OUT/ OUT ADJUST 1: Light up	63	S10	O	FL Disply Segment 1: Light up
14	LED0	O	MT 1: Light up	64	S9	O	FL Disply Segment 1: Light up
15	NC	O	-	65	S8	O	FL Disply Segment 1: Light up
16	NC	O	-	66	S7	O	FL Disply Segment 1: Light up
17	CNVss	-		67	S6	O	FL Disply Segment 1: Light up
18	XRESET	I		68	S5	O	FL Disply Segment 1: Light up
19	NC	O	-	69	S4	O	FL Disply Segment 1: Light up
20	NC	O	-	70	S3	O	FL Disply Segment 1: Light up
21	GND	-	GND	71	S2	O	FL Disply Segment 1: Light up
22	XIN	I	4MHz	72	S1	O	FL Disply Segment 1: Light up
23	XOUT	O	4MHz	73	NC	O	-
24	Vcc	-	+5V	74	NC	O	-
25	LED15	O	HOT REC : A 1: Light up	75	NC	O	-
26	LED14	O	HOT CUE1 : A 1: Light up	76	G9	O	FL Disply Grid 1: Light up
27	LED13	O	HOT CUE2 : A 1: Light up	77	G1	O	FL Disply Grid 1: Light up
28	LED12	O	HOT CUE3 : A 1: Light up	78	G12	O	FL Disply Grid 1: Light up
29	LED11	O	HOT REC : B 1: Light up	79	G13	O	FL Disply Grid 1: Light up
30	LED10	O	HOT CUE1 : B 1: Light up	80	G8	O	FL Disply Grid 1: Light up
31	LED9	O	HOT CUE2 : B 1: Light up	81	G10	O	FL Disply Grid 1: Light up
32	LED8	O	HOT CUE3 : B 1: Light up	82	G11	O	FL Disply Grid 1: Light up
33	XUNIT	I	-	83	G2	O	FL Disply Grid 1: Light up
34	XSTEP	I	-	84	G3	O	FL Disply Grid 1: Light up
35	TxD	O	Communication with a main part.	85	G4	O	FL Disply Grid 1: Light up
36	RxD	I	Communication with a main part.	86	G5	O	FL Disply Grid 1: Light up
37	S36	O	FL Disply Segment 1: Light up	87	G6	O	FL Disply Grid 1: Light up
38	S35	O	FL Disply Segment 1: Light up	88	G7	O	FL Disply Grid 1: Light up
39	S34	O	FL Disply Segment 1: Light up	89	VLOAD	-	VLOAD
40	S33	O	FL Disply Segment 1: Light up	90	SINE1	I	Automatic transmission Input.
41	S32	O	FL Disply Segment 1: Light up	91	SOUT1	O	Automatic transmission Output.
42	S31	O	FL Disply Segment 1: Light up	92	SCLK11	I	Automatic transmission Clock.
43	S30	O	FL Disply Segment 1: Light up	93	TYPE M/XS	I	High: Master CPU Mode.
44	S29	O	FL Disply Segment 1: Light up	94	SBUSY1	I	Automatic transmission control line
45	S28	O	FL Disply Segment 1: Light up	95	XSRDY1	O	Automatic transmission control line.
46	S27	O	FL Disply Segment 1: Light up	96	XRESET_S	O	Slave CPU Reset output 0: Reset
47	S26	O	FL Disply Segment 1: Light up	97	AGND	-	GND
48	S25	O	FL Disply Segment 1: Light up	98	AVREF	-	+5V
49	S24	O	FL Disply Segment 1: Light up	99	TEMPO_REF	I	TEMPO Slider Input.
50	S23	O	FL Disply Segment 1: Light up	100	TEMPO	I	TEMPO Slider Input.

■ PD5764A (CNTA ASSY : IC301)

• Micro computer (Slave CPU)

● Pin Function

Pin No	Pin Name	I/O	Discription	Pin No	Pin Name	I/O	Discription
1	NC	O	-	51	S22	O	FL Disply Segment 1: Light up
2	NC	O	-	52	S21	O	FL Disply Segment 1: Light up
3	NC	O	-	53	S20	O	FL Disply Segment 1: Light up
4	NC	O	-	54	S19	O	FL Disply Segment 1: Light up
5	KEY1	I	-	55	S18	O	FL Disply Segment 1: Light up
6	KEY0	I	-	56	S17	O	FL Disply Segment 1: Light up
7	NC	O	-	57	S16	O	FL Disply Segment 1: Light up
8	NC	O	-	58	S15	O	FL Disply Segment 1: Light up
9	NC	O	-	59	S14	O	FL Disply Segment 1: Light up
10	LED4	O	PLAY/ PAUSE 1: Light up	60	S13	O	FL Disply Segment 1: Light up
11	LED3	O	CUE 1: Light up	61	S12	O	FL Disply Segment 1: Light up
12	LED2	O	IN/ REALTIME CUE 1: Light up	62	S11	O	FL Disply Segment 1: Light up
13	LED1	O	OUT/ OUT ADJUST 1: Light up	63	S10	O	FL Disply Segment 1: Light up
14	LED0	O	MT 1: Light up	64	S9	O	FL Disply Segment 1: Light up
15	JOG1A	I	A PLAYER JOG Input	65	S8	O	FL Disply Segment 1: Light up
16	JOG1B	I	B PLAYER JOG Input	66	S7	O	FL Disply Segment 1: Light up
17	CNVss	-	-	67	S6	O	FL Disply Segment 1: Light up
18	XRESET	I	-	68	S5	O	FL Disply Segment 1: Light up
19	JOG0A	I	A PLAYER JOG Input	69	S4	O	FL Disply Segment 1: Light up
20	JOG0B	I	B PLAYER JOG Input	70	S3	O	FL Disply Segment 1: Light up
21	GND	-	-	71	S2	O	FL Disply Segment 1: Light up
22	XIN	I	4MHz	72	S1	O	FL Disply Segment 1: Light up
23	XOUT	O	4MHz	73	NC	O	-
24	Vcc	-	+5V	74	NC	O	-
25	NC	O	-	75	NC	O	-
26	NC	O	-	76	G9	O	FL Disply Grid 1: Light up
27	NC	O	-	77	G1	O	FL Disply Grid 1: Light up
28	NC	O	-	78	G12	O	FL Disply Grid 1: Light up
29	INT3	I	B PLAYER JOG Trailing edge.	79	G13	O	FL Disply Grid 1: Light up
30	INT2	I	B PLAYER JOG leading edge.	80	G8	O	FL Disply Grid 1: Light up
31	INT1	I	A PLAYER JOG Trailing edge.	81	G10	O	FL Disply Grid 1: Light up
32	INT0	I	A PLAYER JOG leading edge.	82	G11	O	FL Disply Grid 1: Light up
33	NC	I	-	83	G2	O	FL Disply Grid 1: Light up
34	NC	I	-	84	G3	O	FL Disply Grid 1: Light up
35	NC	O	-	85	G4	O	FL Disply Grid 1: Light up
36	NC	I	-	86	G5	O	FL Disply Grid 1: Light up
37	S36	O	FL Disply Segment 1: Light up	87	G6	O	FL Disply Grid 1: Light up
38	S35	O	FL Disply Segment 1: Light up	88	G7	O	FL Disply Grid 1: Light up
39	S34	O	FL Disply Segment 1: Light up	89	VLOAD	-	VLOAD
40	S33	O	FL Disply Segment 1: Light up	90	SINE1	I	Automatic transmission Input.
41	S32	O	FL Disply Segment 1: Light up	91	SOUT1	O	Automatic transmission Output.
42	S31	O	FL Disply Segment 1: Light up	92	SCLK11	O	Automatic transmission Clock.
43	S30	O	FL Disply Segment 1: Light up	93	TYPE M/XS	I	High: Master CPU Mode
44	S29	O	FL Disply Segment 1: Light up	94	SBUSY1	O	Automatic transmission control line.
45	S28	O	FL Disply Segment 1: Light up	95	XSRDY1	I	Automatic transmission control line.
46	S27	O	FL Disply Segment 1: Light up	96	NC	O	-
47	S26	O	FL Disply Segment 1: Light up	97	AGND	-	GND
48	S25	O	FL Disply Segment 1: Light up	98	AVREF	-	+5V
49	S24	O	FL Disply Segment 1: Light up	99	TEMPO_REF	I	TEMPO Slider Input.
50	S23	O	FL Disply Segment 1: Light up	100	TEMPO	I	TEMPO Slider Input.

# CMX-3000, CU-V163

## ■ HD6417709AF100B (MAIN ASSY : IC1204)

• Micro computer

● Pin Function (1/4)

Pin No.	Port Name	Pin Name	I/O	Function
1	MD1	MD1	I	Pull up Clock mode setting
2	MD2	MD2	I	Pull down Clock mode setting
3	Vcc-RTC	Vcc-RTC	-	Power supply (1.8V) for RTC
4	XTAL2	XTAL2	O	NC Crystal resonator for internal RTC
5	EXTAL2	EXTAL2	I	Pull down Crystal resonator for internal RTC
6	Vss-RTC	Vss-RTC	-	Power supply (0V) for RTC
7	NMI	NMI	I	Pull down Non-maskable interrupt request
8	IRQ0/ IRL0/ PTH [0]	ZDET B	IN: pull-up	TC9495F zero detecting flag B (H for soundlessness)
9	IRQ0/ IRL0/ PTH [1]	ZDET A	IN: pull-up	TC9495F zero detecting flag B (H for soundlessness)
10	IRQ0/ IRL0/ PTH [2]	XZERO B	IN: pull-up	DAC zero detecting flag B (L for soundlessness)
11	IRQ0/ IRL0/ PTH [3]	XZERO A	IN: pull-up	DAC zero detecting flag A (L for soundlessness)
12	IRQ4/ PTH [4]	NC	(IN: pull-up)	
13	D31/ PTB [7]	BUSDR B	OUT: high	TC9495F I/F bus direction specification B (H: CPU to TC9495F)
14	D30/ PTB [6]	NC	OUT: high	
15	D29/ PTB [5]	NC	OUT: high	
16	D28/ PTB [4]	NC	OUT: high	
17	D27/ PTB [3]	XMR CHECK	OUT: high	
18	D26/ PTB [2]	XMR NG	OUT: high	
19	VssQ	VssQ	-	Power supply (0V) for I/O
20	D25/ PTB [1]	NC	OUT: high	
21	VccQ	VccQ	-	Power supply (3.3V) for I/O
22	D24/ PTB [0]	NC	OUT: high	
23	D23/ PTB [7]	NC	OUT: high	
24	D22/ PTB [6]	NC	OUT: high	
25	D21/ PTB [5]	NC	OUT: high	
26	D20/ PTB [4]	NC	OUT: high	
27	Vss	Vss	-	Power supply (0V)
28	D19/ PTA [3]	NC	OUT: high	
29	Vcc	Vcc	-	Power supply (1.8V)
30	D18/ PTA [2]	NC	OUT: high	
31	D17/ PTA [1]	NC	OUT: high	
32	D16/ PTA [0]	NC	OUT: high	
33	VssQ	VssQ	-	Power supply (0V) for I/O
34	D15	D15	Z	Data bus
35	VccQ	VccQ	-	Power supply (3.3V) for I/O
36	D14	D14	Z	Data bus
37	D13	D13	Z	Data bus
38	D12	D12	Z	Data bus
39	D11	D11	Z	Data bus
40	D10	D10	Z	Data bus
41	D9	D9	Z	Data bus
42	D8	D8	Z	Data bus
43	D7	D7	Z	Data bus
44	D6	D6	Z	Data bus
45	VssQ	VssQ	-	Power supply (0V) for I/O
46	D5	D5	Z	Data bus
47	VccQ	VccQ	-	Power supply (3.3V) for I/O
48	D4	D4	Z	Data bus
49	D3	D3	Z	Data bus
50	D2	D2	Z	Data bus
51	D1	D1	Z	Data bus
52	D0	D0	Z	Data bus

● Pin Function (2/4)

Pin No.	Port Name	Pin Name	I/O	Function
53	A0	A0	O	Address bus
54	A1	A1	O	Address bus
55	A2	A2	O	Address bus
56	A3	A3	O	Address bus
57	VssQ	VssQ	-	Power supply (0V) for I/O
58	A4	A4	O	Address bus
59	VccQ	VccQ	-	Power supply (3.3V) for I/O
60	A5	A5	O	Address bus
61	A6	A6	O	Address bus
62	A7	A7	O	Address bus
63	A8	A8	O	Address bus
64	A9	A9	O	Address bus
65	A10	A10	O	Address bus
66	A11	A11	O	Address bus
67	A12	A12	O	Address bus
68	A13	A13	O	Address bus
69	VssQ	VssQ	-	Power supply (0V) for I/O
70	A14	A14	O	Address bus
71	VccQ	VccQ	-	Power supply (3.3V) for I/O
72	A15	A15	O	Address bus
73	A16	A16	O	Address bus
74	A17	A17	O	Address bus
75	A18	A18	O	Address bus
76	A19	A19	O	Address bus
77	A20	A20	O	Address bus
78	A21	A21	O	Address bus
79	Vss	Vss	-	Power supply (0V)
80	A22	A22	O	Address bus
81	Vcc	Vcc	-	Power supply (1.8V)
82	A23	A23	O	Address bus
83	VssQ	VssQ	-	Power supply (0V) for I/O
84	A24	A24	O	Address bus
85	VccQ	VccQ	-	Power supply (3.3V) for I/O
86	A25	A25	O	Address bus
87	XBS/PTK [4]	NC	(OUT:high)	
88	XRD	XRD	O	Read strobe
89	XWE0/ DQMLL	XWE0/DQMLL	O	Write strobe
90	XWE1/ DQMLU/WE	XWE1/ DQMLU	O	Write strobe
91	XWE2/ DQMUL/ ICIORD/ PTK [6]	XWE2	O	NC
92	XWE3/ DQMUL/ ICIORD/ PTK [7]	XWE3	O	NC
93	RDXWR	RDWR	O	Read / Write
94	XAUDSYNC/ PTE [7]	AUDSYNC	OTHER	
95	VssQ	VssQ	-	Power supply (0V) for I/O
96	XCS0/ MCS [0]	CS0	O	Chip select 0 (for FLASH)
97	VccQ	VccQ	-	Power supply (3.3V) for I/O
98	XCS2/ PTK [0]	CS2	O	Chip select 2 (for FPGA)
99	XCS3/ PTK [1]	CS3	O	Chip select 3 (for SDRAM)
100	XCS4/ PTK [2]	CS4	O	Chip select 4 (for DSP)
101	XCS5/ CE1A/ PTK [3]	CS5	O	Chip select 5 (connect to FPGA)
102	XCS6/ CE1B	CS6	O	NC
103	XCE2A/ PTE [4]	LOADOUT B	OUT:high	Loading motor control B (Eject direction moves with Low)
104	XCE2B/ PTE [5]	LOADIN B	OUT:high	Loading motor control B (Lead-in direction moves with Low)

# CMX-3000, CU-V163

## ● Pin Function (3/4)

Pin No	Port Name	Pin Name	I/O	Function
105	CKE/ PTK [5]	CKE	O	CK enable (SDRAM)
106	XRAS3L/ PTJ [0]	RAS3L	O	RAS3L (SDRAM)
107	XRAS2L/ PTJ [1]	DSPRST	OUT: high	Reset output for DSP (H: reset)
108	XCASLL/ XCASL/ PTJ [2]	CASL	O	CASL (SDRAM)
109	VssQ	VssQ	-	Power supply (0V) for I/O
110	XCASLH/ XCASU/ PTJ [3]	FPGARST	OUT: high	Reset output for FPGA (H: reset)
111	VccQ	VccQ	-	Power supply (3.3V) for I/O
112	XCASHL/ PTJ [4]	CDRST B	OUT: high	TC9495F reset B (H: reset)
113	XCASHH/ PTJ [5]	CDRST A	OUT: high	TC9495F reset A (H: reset)
114	XDAK0/ PTD [5]	DACK0	O	FPGA DMA acknowledge 0
115	XDAK1/ PTD [7]	DACK1	O	FPGA DMA acknowledge 1
116	XCAS2L/ PTE [6]	LOADIN A	OUT: high	Loading motor control A (Lead-in direction moves with Low)
117	XCAS2H/ PTE [3]	LOADOUT A	OUT: high	Loading motor control A (Eject direction moves with Low)
118	XRAS3U/ PTE [2]	MUTE B	OUT: high	Audio output stage mute B (H: mute ON)
119	XRAS3U/ PTE [1]	MUTE A	OUT: high	Audio output stage mute A (H: mute ON)
120	TDO/ PTE [0]	TDO	OTHER	-
121	XBACK	BACK	O	NC
122	XBREQ	BREQ	I	Pull up
123	XWAIT	WAIT	I	Pull up
124	XRESETM	RESETM	I	Pull up
125	XADTRG/ PTH [5]	FPGA DONE	IN: pull-up	DONE for FPGA configuration
126	XIOIS16/ PTG [7]	RY/ XBY	IN: pull-up	Connect to flash ROM
127	XASEMD0/ PTG [6]	ASEMD0	OTHER	-
128	XASEBRKAK/ PTG [5]	ASEBRKAK	OTHER	-
129	PTG [4]	FPGA XINIT	IN: pull-up	INIT for FPGA configuration
130	AUDATA [3]/ PTG [3]	AUDATA [3]	OTHER	-
131	AUDATA [2]/ PTG [2]	AUDATA [3]	OTHER	-
132	Vss	Vss	-	Power supply (0V)
133	AUDATA [1]/ PTG [1]	AUDATA [1]	OTHER	-
134	Vcc	Vcc	-	Power supply (1.8V)
135	AUDATA [0]/ PTG [0]	AUDATA [0]	OTHER	-
136	XTRST/ PTF [7]/ PINT [15]	TRST	OTHER	-
137	TMS/ PTE [6]/ PINT [14]	TMS	OTHER	-
138	TDI/ PTE [5]/ PINT [13]	TDI	OTHER	-
139	TCK/ PTF [4]/ PINT [12]	TCK	OTHER	-
140	XIRLS [3]/ PTF [3]/ PINT [11]	LPS1 A	IN: pull-up	Loading switch A (switch ON: Low)
141	XIRLS [2]/ PTF [2]/ PINT [10]	LPS2 A	IN: pull-up	Loading switch A (switch ON: Low)
142	XIRLS [1]/ PTF [1]/ PINT [9]	LPS1 B	IN: pull-up	Loading switch B (switch ON: Low)
143	XIRLS [0]/ PTF [0]/ PINT [8]	LPS2 B	IN: pull-up	Loading switch B (switch ON: Low)
144	MD0	MD0	I	Pull down Clock mode setting
145	Vcc-PLL1	Vcc-PLL1	-	Power supply (1.8V) for PLL1
146	CAP1	CAP1	-	C External capacitance pin for PLL1
147	Vss-PLL1	Vss-PLL1	-	Power supply (0V) for PLL1
148	Vss-PLL2	Vss-PLL2	-	Power supply (0V) for PLL2
149	CAP2	CAP2	-	C External capacitance pin for PLL2
150	Vcc-PLL2	Vcc-PLL2	-	Power supply (1.8V) for PLL2
151	AUDCK/ PTH [6]	AUDCK	OTHER	-
152	Vss	Vss	-	Power supply (0V)
153	Vss	Vss	-	Power supply (0V)
154	Vcc	Vcc	-	Power supply (1.8V)
155	XTAL	XTAL	O	12MHz ceramic resonator
156	EXTAL	EXTAL	I	12MHz ceramic resonator



● Pin Function (4/4)

Pin No	Port Name	Pin Name	I/O	Function
157	STATUS0/ PTJ [6]	DAC ML B	OUT: high	LATCH B for DAC
158	STATUS0/ PTJ [7]	DAC ML A	OUT: high	LATCH A for DAC
159	TCLK/ PTH [7]	FPGA XPRG	OUT: high	PRG for FPGA configuration
160	XIRQOUT	NC	O	
161	VssQ	VssQ	-	Power supply (0V) for I/O
162	CKIO	CKIO	O	Clock output (48MHz) to FPGA and DSP
163	VccQ	VccQ	-	Power supply (3.3V) for I/O
164	TxD0/ SCPT [0]	DAC MD	O	Serial data / FPGA configuration for DAC
165	SOK0/ SCPT [1]	DAC MC	O	Serial clock / FPGA configuration for DAC
166	TxD1/ SCPT [2]	TXD1	OUT: high	DATA IN/ OUT communication output
167	SCK1/ SCPT [3]	BUSDR b	OUT:high	TC9495F I/F bus direction specification A (H: CPU to TC9495F)
168	TxD2/ SCPT [4]	TxD2	O	Serial communication output with the function section
169	SCK2/ SCPT [5]	DRVMUTE B	OUT:high	Loading driver IC mute B (H: mute ON)
170	SCK2/ SCPT [6]	DRVMUTE A	OUT:high	Loading driver IC mute A (H: mute ON)
171	RxD0/ SCPT [0]	NC	(IN: pull-up)	
172	RxD1/ SCPT [2]	RxD1	I	DATA IN/OUT Remote control unit communication input for service
173	Vss	Vss	-	Power supply (0V)
174	RxD2/ SCPT [4]	RxD2	I	Serial communication input with the function section
175	Vcc	Vcc	-	Power supply (1.8V)
176	CTS2/ IRQ5/ SCPT [7]	NC	(IN: pull-up)	
177	MCS [7]/ PTC [7]/ PINT [7]	XCDCE A	OUT: high	TC9495F chip enable signal A
178	MCS [6]/ PTC [6]/ PINT [6]	BUCK A	OUT: high	TC9495F microcomputer I/F clock signal A
179	MCS [5]/ PTC [5]/ PINT [5]	XCDCE B	OUT: high	TC9495F chip enable signal B
180	MCS [4]/ PTC [4]/ PINT [4]	BUCK B	OUT: high	TC9495F microcomputer I/F clock signal B
181	VssQ	VssQ	-	Power supply (0V) for I/O
182	XWAKEUP/ PTD [3]	BUS3 A	IN(Bidirection)	TC9495F microcomputer I/F data 3A
183	VccQ	VccQ	-	Power supply (3.3V) for I/O
184	XRESETOUT/ PTD [2]	BUS2 A	IN(Bidirection)	TC9495F microcomputer I/F data 2A
185	MCS [3]/ PTC [3]/ PINT [3]	BUS3 B	IN(Bidirection)	TC9495F microcomputer I/F data 3B
186	MCS [2]/ PTC [2]/ PINT [2]	BUS2 B	IN(Bidirection)	TC9495F microcomputer I/F data 2B
187	MCS [1]/ PTC [1]/ PINT [1]	BUS1 B	IN(Bidirection)	TC9495F microcomputer I/F data 1B
188	MCS [0]/ PTC [0]/ PINT [0]	BUS0 B	IN(Bidirection)	TC9495F microcomputer I/F data 0B
189	DRAK0/ PTD [1]	BUS1 A	IN(Bidirection)	TC9495F microcomputer I/F data 1A
190	DRAK1/ PTD [0]	BUS0 A	IN(Bidirection)	TC9495F microcomputer I/F data 0A
191	XDREQ0/ PTD [4]	DREQ0	I	FPGA DMA data request 0
192	XDREQ0/ PTD [6]	DREQ1	I	FPGA DMA data request 1
193	XRESETP	XRESET	I	Reset input
194	CA	CA	I	Pull up
195	MD3	MD3	I	Pull down Bus width setting for area 0
196	MD4	MD4	I	Pull up Bus width setting for area 0
197	MD5	MD5	I	Pull up Endure setting
198	AVss	AVss	-	Analog power supply (0V)
199	AN [0]/ PTL [0]	CDINSIDE B	IN: pull-up	Pickup inside SW B (switch ON: Low)
200	AN [1]/ PTL [1]	CDINSIDE A	IN: pull-up	Pickup inside SW A (switch ON: Low)
201	AN [2]/ PTL [2]	EJECT SW B	IN: pull-up	EJECT SW B (switch ON: Low)
202	AN [3]/ PTL [3]	EJECT SW A	IN: pull-up	EJECT SW A (switch ON: Low)
203	AN [4]/ PTL [4]	D MODE SW	IN: pull-up	DIGITAL MODE switching SW (DIGITAL ON: Low)
204	AN [5]/ PTL [5]	REMIN	(IN: pull-up)	DATA IN/ OUT insertion detecting pin (Jack insertion: High)
205	AVcc (3.3V)	AVcc (3.3V)	-	Analog power supply (3.3V)
206	AN [6]/ DA [1]/ PTL [6]	XUNIT	IN: pull-up	-
207	AN [7]/ DA [0]/ PTL [7]	NC	(IN: pull-up)	-
208	AVss	AVss	-	Analog power supply (0V)

## 8. PANEL FACILITIES AND SPECIFICATIONS

### 8.1 PANEL FACILITIES

#### ■ Player Section

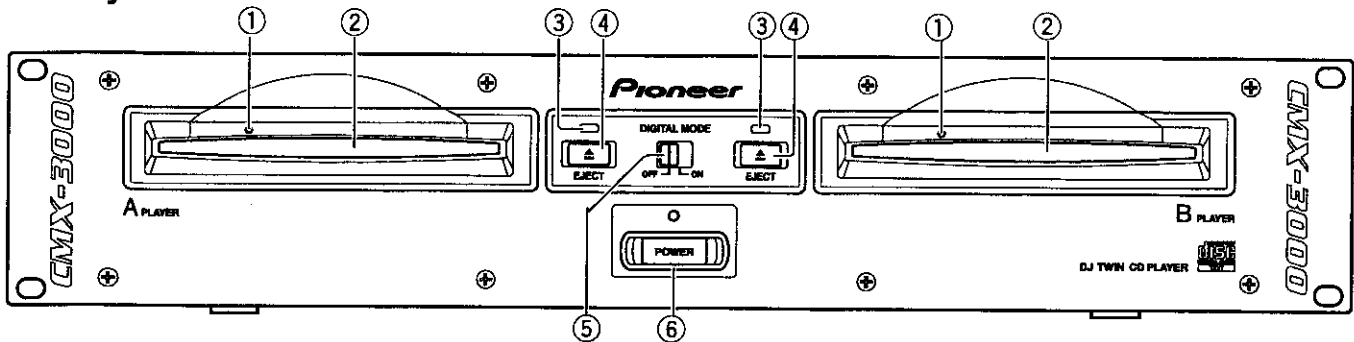

① **Manual ejection hole**

② **Disc insertion slot**

When using 3 inch/8 cm discs, discs must be inserted in the commercially available CD adapter before insertion.

③ **Disc loading indicator**

This indicator flashes when a disc is being inserted into or ejected from the disc insertion slot and lights up when a disc has been inserted.

④ **EJECT button (▲)**

Pressing this button while cueing is on standby or play is paused will eject the disc from the player.

⑤ **DIGITAL MODE switch**

Set to On when the digital output is to be used. When set to On, the DJ functions do not function. (Functions marked \* do not operate in this mode.) And the muted pause mode is used instead of the audible pause mode.

⑥ **POWER switch and indicator**

#### ■ Remote Control Unit Section

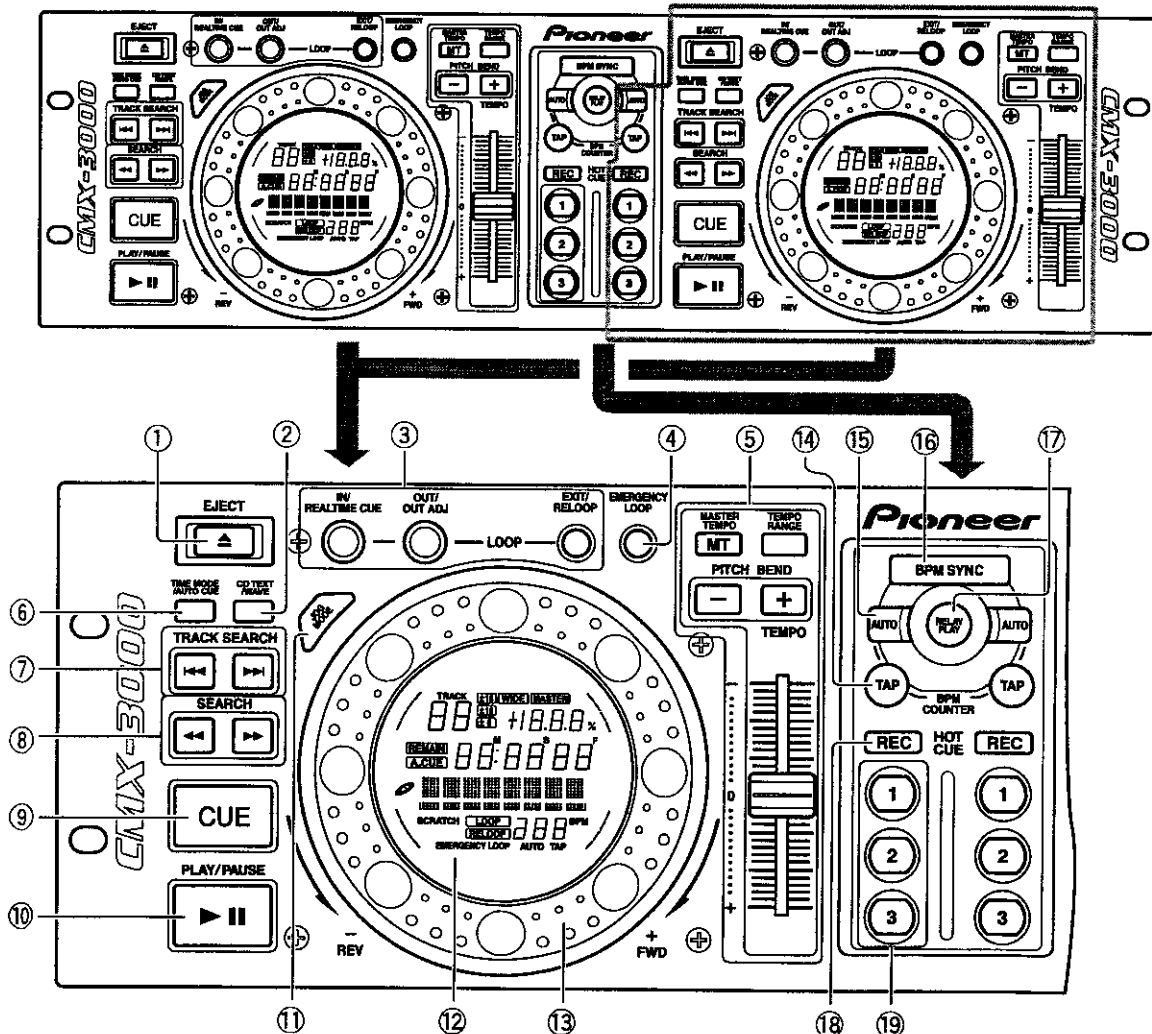

Operation buttons indicated by an asterisk (\*) are not supported in digital mode.

① **EJECT button (▲)**

② **CD TEXT/WAVE button**

Each time the button is pressed the function changes alternately as follows:

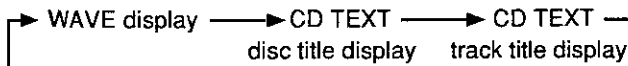

During digital mode, switches between  
 CD TEXT ←→ CD TEXT  
 disc title display track title display

③ **LOOP control buttons (\*)**

④ **EMERGENCY LOOP button (\*)**

When this button is pressed, the current point is set as the loop in-point, and loop play begins with an automatically set out-point.

⑤ **TEMPO controls (\*)**

**Tempo control range button (TEMPO RANGE):**

Pressing this button causes the variable range of the tempo control slide to change each time the button is pressed.

**MASTER TEMPO button and indicator:**

Pressing this button causes the master tempo feature to be powered on or off each time it is pressed.

**Tempo control slide:**

Moving this slider in the positive (+) direction away from the center position (normal playback tempo) causes the tempo to become faster, and moving it in the negative (-) direction causes the tempo to become slower.

**PITCH BEND buttons (+, -):**

When pressed during playback, causes pitch bend. Pressing the "+" button causes pitch to accelerate, while pressing the "-" button causes pitch to decelerate.

⑥ **Time mode/Auto cueing button (\*)**

**(TIME MODE/AUTO CUE)**

**TIME MODE:**

Pressing this button causes the elapsed time and remaining time (REMAIN) of the current track to be displayed in succession on the time display of the display unit.

**AUTO CUE:**

⑦ **TRACK SEARCH button (◀◀, ▶▶)**

⑧ **SEARCH button (◀◀, ▶▶)**

⑨ **CUE button and indicator (\*)**

- Cueing point settings
- Cueing point sampler
- Back cueing
- Cueing point adjust

⑩ **PLAY/PAUSE button (▶ II) and indicator**

⑪ **JOG MODE button (\*)**

Each time this button is pressed, the jog mode switches alternately between CDJ jog mode and SCRATCH jog mode.

⑫ **Display**

⑬ **Jog dial (+ FWD/- REV) (\*)**

⑭ **TAP button (\*)**

When pressed during playback, the BPM counter switches to manual mode, and the BPM value is calculated from the interval at which the TAP button is pressed. A BPM value in the range 40 to 199 BPM (varies with the tempo change rate) can be entered when the tempo change rate is 0%.

⑮ **AUTO button (\*)**

Press for automatic BPM count

⑯ **BPM synchro button (BPM SYNC) and indicator (\*)**

Each time the button is pressed, switches BPM synchro function ON/OFF. BPM SYNC indicator flashes during ON, and lights steadily when OFF.

⑰ **RELAY PLAY button and indicator (\*)**

⑱ **HOT CUE recording mode button (REC) and indicator (\*)**

Press to switch the HOT CUE button's function (record/access). In the record mode, the indicator lights.

⑲ **HOT CUE buttons (1, 2, 3) and indicator (\*)**

Use to select the memory (1, 2, 3) into which you wish to program hot cue point information, loop information, and scratch mode information.

## ■ Display

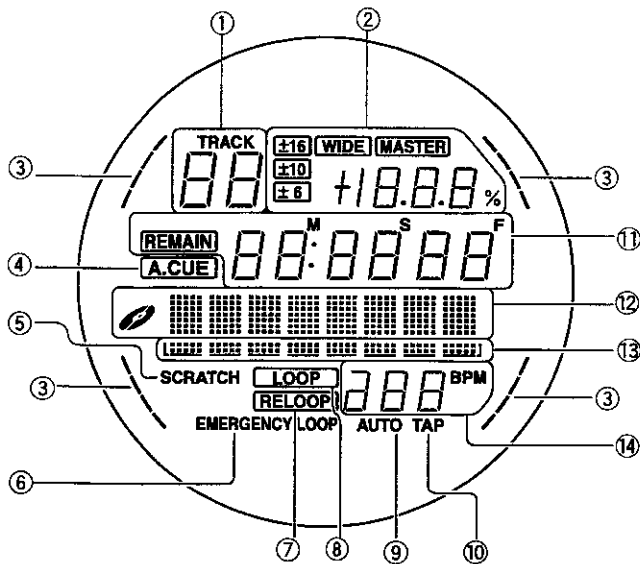

### ① TRACK number display

Displays the track number of the track currently being played.

### ② Playback speed display

**Tempo control range display ( $\pm 6$ ,  $\pm 10$ ,  $\pm 16$ , WIDE)**  
Displays the variable range mode of the tempo control slide.

#### MASTER indicator

MASTER indicator on the master player lights during BPM synchro play.

#### Tempo change rate display

Displays the rate of change of the tempo as specified using the tempo control slide.

### ③ Ring display

During relay play, displays disc rotation status. During BPM synchro mode, the display occurs in rhythm with the beat.

### ④ Auto cueing indicator (A. CUE)

Lights up when auto cueing is turned on.

### ⑤ SCRATCH indicator

When jog mode is set to "SCRATCH," flashes during write to the scratch memory, and lights steadily when data is fully written to the memory.

### ⑥ EMERGENCY LOOP indicator

Flashes during loop play in the Emergency Loop mode.

### ⑦ RELOOP indicator

Lights to indicate loop play is possible, and during loop play.

### ⑧ LOOP indicator

Lights during loop play.

### ⑨ Automatic BPM Count indicator (AUTO)

Lights during automatic BPM count mode.

### ⑩ TAP mode indicator

Lights during TAP BPM count mode. Indicator goes out for approximately 0.2 second the instant TAP button is pressed.

### ⑪ Time display

Used to display the elapsed playback time (when the REMAIN indicator is unlit) or the remaining playback time (when the REMAIN indicator is lit) of the current track in minutes (M), seconds (S), and frames (F).

### ⑫ WAVE Display / Character Display

During WAVE display, indicates the volume level of the currently playing track. During character display, displays CD TEXT. Characters displayable are limited to alphabet, numerals, and certain symbols. The array displays either the disc title or the track title. When disc title is displayed, the  mark lights.

### ⑬ Playback position display

Used to display a full-scale bar graph for the track being played to make it possible to get an intuitive feel of the elapsed and remaining play time.

- Display as it appears when displaying elapsed time:  
All indicators unlit and then indicators light up in sequence from left
- Display as it appears when displaying remaining time:  
All indicators lit and then indicators are turned off in sequence from left
- Display as it appears when there are less than 30 seconds remaining in a track:  
Slow flashing
- Display as it appears when there are less than 15 seconds remaining in a track:  
Rapid flashing

### ⑭ BPM display

Used to display the number of BPM for the current track. Note that it may not be possible to count BPM in the automatic BPM count mode for some tracks. Then use the TAP BPM count mode to do this.

## 8.2 SPECIFICATIONS

### ■ CMX-3000/KUXJ

#### 1. General

System ..... Compact disc digital audio system  
 Discs used ..... Compact discs  
 Power requirements ..... AC 120 V, 60 Hz  
 Power consumption ..... 49 W  
 Operating temperature ..... +5°C to +35°C (+41°F to +95°F)  
 Operating humidity ..... 5% to 85%  
 (There should be no condensation of moisture.)

#### Weight

Remote controller ..... 2.0 kg (4 lbs 7 oz)  
 Player ..... 5.6 kg (12 lbs 6 oz)

#### Dimensions

Remote controller ..... 482 (W) x 132 (D) x 82 (H) mm  
 18-31/32 (W) x 5-3/16 (D) x 3-7/32 (H) in.  
 Player ..... 482 (W) x 252 (D) x 90 (H) mm  
 18-31/32 (W) x 9-15/16 (D) x 3-9/16 (H) in.

#### 2. Audio section

Frequency response ..... 4 Hz to 20 kHz  
 Signal-to-noise ratio ..... 115 dB or more  
 Distortion rate ..... 0.006%

#### 3. Accessories

- Operating instructions ..... 1
- Power cord ..... 1
- Audio cable ..... 2
- Control cord ..... 2
- Forced ejection pin ..... 1
- Specialized connection cable for the remote controller ..... 1
- Limited warranty ..... 1

#### NOTE:

*Specifications and design are subject to possible modification without notice.*

### ■ CMX-3000/WYXJ

#### 1. General

System ..... Compact disc digital audio system  
 Discs used ..... Compact discs  
 Power requirements ..... AC 220-240 V, 50/60 Hz  
 Power consumption ..... 49 W  
 Operating temperature ..... +5°C to +35°C  
 Operating humidity ..... 5% to 85%  
 (There should be no condensation of moisture.)

#### Weight

Remote controller ..... 2.0 kg  
 Player ..... 5.6 kg

#### Dimensions

Remote controller ..... 482 (W) x 132 (D) x 82 (H) mm  
 Player ..... 482 (W) x 252 (D) x 90 (H) mm

#### 2. Audio section

Frequency response ..... 4 Hz to 20 kHz  
 Signal-to-noise ratio ..... 115 dB or more  
 Distortion rate ..... 0.006%

#### 3. Accessories

- Operating instructions ..... 1
- Power cord ..... 1
- Audio cable ..... 2
- Control cord ..... 2
- Forced ejection pin ..... 1
- Specialized connection cable for the remote controller ..... 1

#### NOTE:

*Specifications and design are subject to possible modification without notice.*

### ■ CMX-3000/RLBXJ

#### 1. General

System ..... Compact disc digital audio system  
 Discs used ..... Compact discs  
 Power requirements ..... AC 110-120 V/220-240 V, 50/60 Hz  
 Power consumption ..... 49 W  
 Operating temperature ..... +5°C to +35°C  
 Operating humidity ..... 5% to 85%  
 (There should be no condensation of moisture.)

#### Weight

Remote controller ..... 2.0 kg  
 Player ..... 5.6 kg

#### Dimensions

Remote controller ..... 482 (W) x 132 (D) x 82 (H) mm  
 Player ..... 482 (W) x 252 (D) x 90 (H) mm

#### 2. Audio section

Frequency response ..... 4 Hz to 20 kHz  
 Signal-to-noise ratio ..... 115 dB or more  
 Distortion rate ..... 0.006%

#### 3. Accessories

- Operating instructions ..... 1
- Power cord ..... 1
- Audio cable ..... 2
- Control cord ..... 2
- Forced ejection pin ..... 1
- Specialized connection cable for the remote controller ..... 1

#### NOTE:

*Specifications and design are subject to possible modification without notice.*

### ■ Accessories

Audio Cable x2  
 (VDE1064) L=1.5 m



Control Cord x2  
 (PDE1267) L=1 m



Power Cord x1  
 (KUXJ type : ADG7022  
 (WYXJ, TLXJ type: ADG1154)



Forced Ejection Pin x1  
 (DEX1013)



Specialized connection cable  
 for the remote controller  
 (DDE1122) L=3 m x1



Operating instructions

Limited warranty (KUXJ type only)