

# Service Manual

ORDER NO.  
RRV1747

STEREO DOUBLE CASSETTE DECK

# CT-W4000

● Refer to the service manual RRV1540 for CT-W205R/KUXJ.

THIS MANUAL IS APPLICABLE TO THE FOLLOWING MODEL(S) AND TYPE(S).

Type	Model	Power Requirement	Remarks
	CT-W4000		
KUXJ	○	AC120V	

# CT-W4000

## 1. CONTRAST OF MISCELLANEOUS PARTS

- NOTES : ● Parts marked by "NSP" are generally unavailable because they are not in our Master Spare Parts List.
- The  $\Delta$  mark found on some component parts indicates the importance of the safety factor of the part. Therefore, when replacing, be sure to use parts of identical designation.
  - When ordering resistors, first convert resistance values into code form as shown in the following examples.
- Ex. 1 When there are 2 effective digits (any digit apart from 0), such as 560 ohm and 47k ohm (tolerance is shown by J = 5%, and K = 10%).
- 560  $\Omega$   $\rightarrow$   $56 \times 10^1 = 561$  ..... RD1/4PU 5 6 1 J  
 47k  $\Omega$   $\rightarrow$   $47 \times 10^3 = 473$  ..... RD1/4PU 4 7 3 J  
 0.5  $\Omega$   $\rightarrow$  R50 ..... RN2H R 5 0 K  
 1  $\Omega$   $\rightarrow$  1R0 ..... RS1P 1 R 0 K
- Ex. 2 When there are 3 effective digits (such as in high precision metal film resistors).
- 5.62k  $\Omega$   $\rightarrow$   $562 \times 10^1 = 5621$  ..... RN1/4PC 5 6 2 1 F

## CONTRAST OF CT-W4000/KUXJ AND CT-W205R/KUXJ

CT-W4000/KUXJ AND CT-W205R/KUXJ have the same construction except for the following:

Mark	Symbol & Description	Part No.		Remarks
		CT-W205R/KUXJ	CT-W4000/KUXJ	
NSP	MAIN Unit	RWZ3930	RWZ4178	No. 1
	SUB Unit	RWZ3931	RWZ4179	
	TRANSFORMER 2 Unit	RWZ3872	RWZ4180	
	1 Mechanism Unit	RYM1261	RYM1255	
	2 Mechanism Unit	RYM1262	RYM1256	
	Disc Guard	Not used	PNM1245	
	Front Panel	RAH2704	RAH2818	
	Rear Panel	RNA2050	RNA2144	
	Packing Case	RHG1717	RHG1799	
	Operating Instructions (English)	RRB1169	RRB1177	

Note: The numbers in the remarks column correspond to the numbers on the exploded diagram. Refer to "● Exploded View".

### ● Exploded View

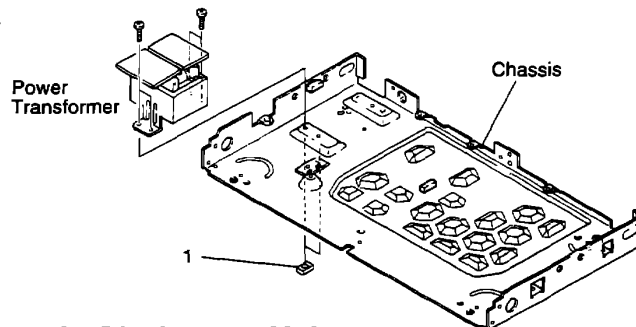

### 1 Mechanism Unit and 2 Mechanism Unit

RYM1255 and RYM1261 or RYM1256 and RYM1262 have the same construction except for the following:

Mark	Symbol & Description	Part No.		Remarks
		RYM1261, RYM1262	RYM1255, RYM1256	
	PLATE HD BLK	RXA1682	RXA1748	For 1 Mechanism Unit
	PCB CONTROL BLK	RXA1623	RXA1698	For 1 Mechanism Unit
	PLATE HD BLK	RXA1683	RXA1749	For 2 Mechanism Unit
	CLUTCH BLK Assy	RXA1631	RXA1694	
	MTR MAIN BLK	RXM1075	RXM1084	
	F/W ASSY	RXA1295	RXA1695	

**■ CONTRAST OF PCB ASSEMBLIES**

**MAIN Unit**

RWZ4178 and RWZ3930 have the same construction except for the following:

Mark	Symbol & Description	Part No.		Remarks
		RWZ3930	RWZ4178	
	IC301, IC651, IC701 Q101, Q102, Q165, Q166, Q201-Q203, Q301-Q308, Q313, Q802, Q804, Q806, Q852, Q854, Q856 Q807, Q857, Q1002, Q1003 Q1004	XRA15218 XDC124ES  2SC3311A XDA114ES	BA15218 DTC124ES  2SC1740S DTA114ES	
	C303, C304 C407 C1014	CKSQYB332K50 CFTXA123J50 PCH1117	CKSQYB152K50 CQMA123J50 CEAS102M10	
	R305, R306 R307, R308 R309, R310 R311, R312 R313, R314	RD1/4PU102J RD1/4PU332J RD1/4PU912J RD1/4PU272J RD1/4PU822J	RD1/4PU112J RD1/4PU182J RD1/4PU103J RD1/4PU472J RD1/4PU752J	
	R315, R316 R409 R410 R801 R802	RD1/4PU561J RD1/2LMF201J RD1/2LMF181J RD1/4PU242J RD1/4PU102J	RD1/4PU471J RD1/2LMF221J RD1/2LMF131J RD1/4PU273J RD1/4PU472J	
	R803, R852 R851 VR801, VR852 VR851	RD1/4PU561J RD1/4PU222J RCP1044 RCP1019	RD1/4PU912J RD1/4PU273J RCP1046 RCP1045	

**SUB Unit**

RWZ4179 and RWZ3931 have the same construction except for the following:

Mark	Symbol & Description	Part No.		Remarks
		RWZ3931	RWZ4179	
	D1511	SLR-342UCT31	SLR-342VCT31	

**TRANSFORMER 2 Unit**

Although RWZ4180 and RWZ3872 are different in part number, they consist of the same components.

# CT-W4000

## 2. ADJUSTMENT

Note: Adjustment of CT-W4000/KUXJ are the same as that of CT-W205R/KUXJ except for the following.

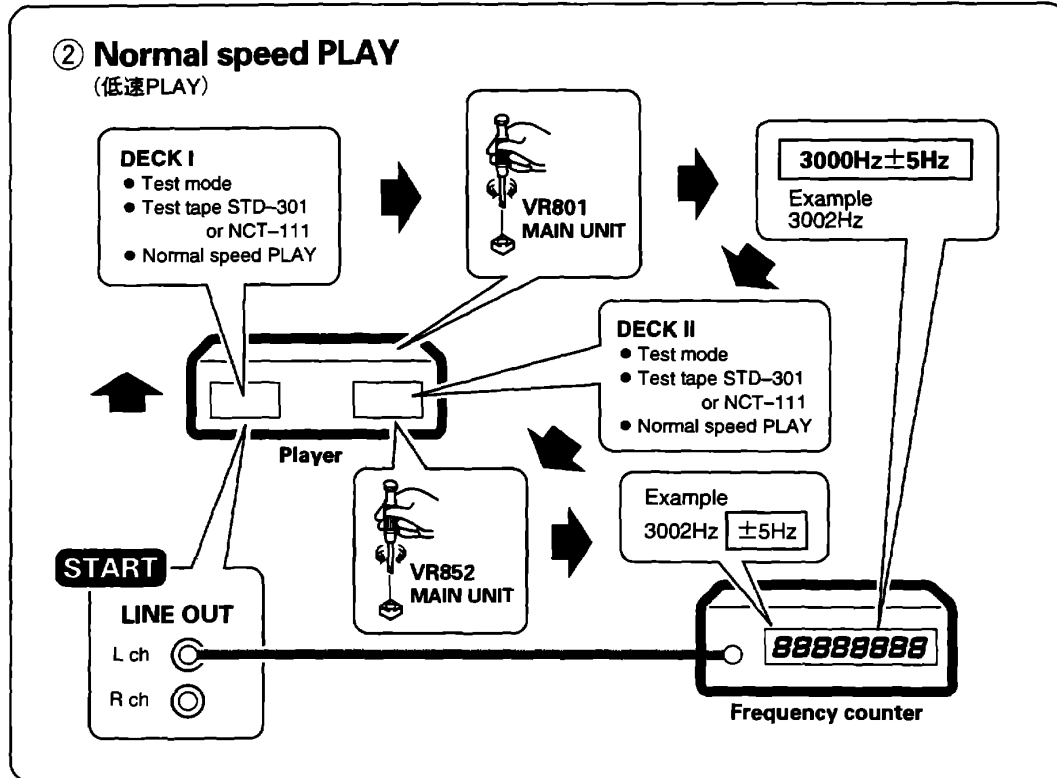

# Service Manual

**PIONEER**  
The Art of Entertainment

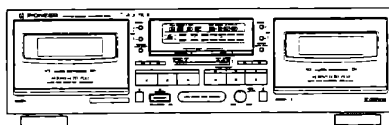

ORDER NO.  
RRV1540

STEREO DOUBLE CASSETTE DECK

# CT-W205R

THIS MANUAL IS APPLICABLE TO THE FOLLOWING MODEL(S) AND TYPE(S).

Type	Model	Power Requirement	Remarks
	CT-W205R		
KUXJ	○	AC120V	_____
KCXJ	○	AC120V	_____
HVXJ	○	AC230-240V	_____
HYXJ	○	AC220-230V	_____
HPWXJ	○	AC230-240V	_____
SDXJ	○	AC110V/120-127V/220V/230-240V	With voltage selector
SLXJ	○	AC110V/120-127V/220V/230-240V	With voltage selector

## CONTENTS

1. SAFETY INFORMATION.....	2
2. EXPLODED VIEWS, PACKING AND PARTS LIST .....	3
3. BLOCK DIAGRAM .....	10
4. TEST MODE .....	11
5. ADJUSTMENTS.....	12
6. SCHEMATIC DIAGRAMS .....	19
7. PCB CONNECTION DIAGRAM.....	23
8. PCB PARTS LIST .....	26
9. IC INFORMATION .....	29
10. PANEL FACILITIES.....	31
11. SPECIFICATIONS .....	32

**PIONEER ELECTRONIC CORPORATION** 4-1, Meguro 1-Chome, Meguro-ku, Tokyo 153, Japan

**PIONEER ELECTRONICS SERVICE, INC.** P.O. Box 1760, Long Beach, CA 90801-1760, U. S. A.

**PIONEER ELECTRONIC (EUROPE) N.V.** Haven 1087 Keetberglaan 1, 9120 Melsele, Belgium

**PIONEER ELECTRONICS ASIACENTRE PTE. LTD.** 501 Orchard Road, #10-00 Lane Crawford Place, Singapore 0923

© PIONEER ELECTRONIC CORPORATION 1996

T-SSG APR. 1996 Printed in Japan

# 1. SAFETY INFORMATION



This service manual is intended for qualified service technicians; it is not meant for the casual do-it-yourselfer. Qualified technicians have the necessary test equipment and tools, and have been trained to properly and safely repair complex products such as those covered by this manual. Improperly performed repairs can adversely affect the safety and reliability of the product and may void the warranty. If you are not qualified to perform the repair of this product properly and safely, you should not risk trying to do so and refer the repair to a qualified service technician.

**WARNING**

Lead in solder used in this product is listed by the California Health and Welfare agency as a known reproductive toxicant which may cause birth defects or other reproductive harm (California Health & Safety Code, Section 25249.5). When servicing or handling circuit boards and other components which contain lead in solder, avoid unprotected skin contact with the solder. Also, when soldering do not inhale any smoke or fumes produced.



**NOTICE**

(FOR CANADIAN MODEL ONLY)

Fuse symbols  (fast operating fuse) and/or  (slow operating fuse) on PCB indicate that replacement parts must be of identical designation.

**REMARQUE**

(POUR MODÈLE CANADIEN SEULEMENT)

Les symboles de fusible  (fusible de type rapide) et/ou  (fusible de type lent) sur CCI indiquent que les pièces de remplacement doivent avoir la même désignation.

(FOR USA MODEL ONLY)

## 1. SAFETY PRECAUTIONS

The following check should be performed for the continued protection of the customer and service technician.

### LEAKAGE CURRENT CHECK

Measure leakage current to a known earth ground (water pipe, conduit, etc.) by connecting a leakage current tester such as Simpson Model 229-2 or equivalent between the earth ground and all exposed metal parts of the appliance (input/output terminals, screwheads, metal overlays, control shaft, etc.). Plug the AC line cord of the appliance directly into a 120V AC 60Hz outlet and turn the AC power switch on. Any current measured must not exceed 0.5mA.

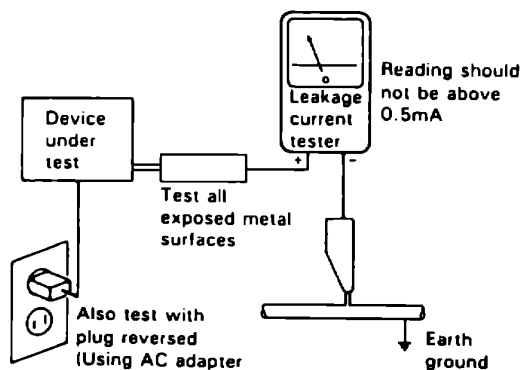

AC Leakage Test

ANY MEASUREMENTS NOT WITHIN THE LIMITS OUTLINED ABOVE ARE INDICATIVE OF A POTENTIAL SHOCK HAZARD AND MUST BE CORRECTED BEFORE RETURNING THE APPLIANCE TO THE CUSTOMER.

## 2. PRODUCT SAFETY NOTICE

Many electrical and mechanical parts in the appliance have special safety related characteristics. These are often not evident from visual inspection nor the protection afforded by them necessarily can be obtained by using replacement components rated for voltage, wattage, etc. Replacement parts which have these special safety characteristics are identified in this Service Manual.

Electrical components having such features are identified by marking with a  $\Delta$  on the schematics and on the parts list in this Service Manual.

The use of a substitute replacement component which does not have the same safety characteristics as the PIONEER recommended replacement one, shown in the parts list in this Service Manual, may create shock, fire, or other hazards.

Product Safety is continuously under review and new instructions are issued from time to time. For the latest information, always consult the current PIONEER Service Manual. A subscription to, or additional copies of, PIONEER Service Manual may be obtained at a nominal charge from PIONEER.

## 2. EXPLODED VIEWS, PACKING AND PARTS LIST

**NOTES:**

- Parts marked by "NSP" are generally unavailable because they are not in our Master Spare Parts List.
- The  $\Delta$  mark found on some component parts indicates the importance of the safety factor of the parts. Therefore, when replacing, be sure to use parts of identical designation.
- Parts marked by "⊙" are not always kept in stock. Their delivery time may be longer than usual or they may be unavailable.

### 1. EXTERIOR AND PACKING

**■ CONTRAST OF KUXJ, KCXJ, HVXJ, HXJ, HPWXJ, SDXJ AND SLXJ TYPES**

KUXJ, KCXJ, HVXJ, HXJ, HPWXJ, SDXJ and SLXJ types have the same construction except for the following:

Mark	No.	Symbol & Description	Part No.							Remarks
			KUXJ type	KCXJ type	HVXJ type	HXJ type	HPWXJ type	SDXJ type	SLXJ type	
NSP	1	Main Unit	RWZ3930	RWZ3930	RWZ3727	RWZ3727	RWZ3952	RWZ3728	RWZ3728	
	2	SUB Unit	RWZ3931	RWZ3931	RWZ3729	RWZ3729	RWZ3953	RWZ3730	RWZ3730	
	4	Transformer 2 Unit	RWZ3872	RWZ3872	RWZ3772	RWZ3772	RWZ3954	RWZ3954	RWZ3954	
	$\Delta$ 5	Strain Relief	CM-22C	CM-22C	CM-22B	CM-22B	CM-22B	CM-22B	CM-22B	
	$\Delta$ 6	Fuse (FU1, FU2, 1.25A)	REK1076	REK1076	Not used	Not used	Not used	Not used	Not used	
	$\Delta$ 6	Fuse (FU1, FU2, T1.25A)	Not used	Not used	REK1023	REK1023	REK1023	REK1023	REK1023	
	$\Delta$ 7	AC Power Cord	PDG1015	PDG1015	PDG1055	PDG1043	ADG1159	ADG1157	PDG1043	
	$\Delta$ 9	Power Transformer (AC120V)	RTT1311	RTT1311	Not used	Not used	Not used	Not used	Not used	
	$\Delta$ 9	Power Transformer (AC220-230V/230-240V)	Not used	Not used	RTT1312	RTT1312	RTT1312	Not used	Not used	
	$\Delta$ 9	Power Transformer (AC110/120-127/220/230-240V)	Not used	Not used	Not used	Not used	Not used	RTT1313	RTT1313	
	12	Rubber Sheet	AEB1111	AEB1111	Not used	Not used	AEB1111	AEB1111	AEB1111	
	13	Foot Assy	AEC1531	AEC1531	Not used	Not used	AEC1531	AEC1531	AEC1531	
	28	Power Knob	RAC1883	RAC1883	RAC2110	RAC2110	RAC1883	RAC1883	RAC1883	
	32	Front Panel	RAH2704	RAH2704	RAH2703	RAH2703	RAH2704	RAH2704	RAH2704	
	38	Rear Panel	RNA2050	RNA2050	RNA2053	RNA2049	RNA2053	RNA2051	RNA2052	
	42	Operating Instructions (English)	RRB1169	RRB1169	RRB1169	Not used	RRB1169	Not used	Not used	
	42	Operating Instructions (French)	Not used	RRD1186	Not used	Not used	Not used	Not used	Not used	
	42	Operating Instructions (Dutch/Italian/German/Swedish/Spanish/Portuguese)	Not used	Not used	Not used	RRE1131	Not used	Not used	Not used	
	42	Operating Instructions (English/French)	Not used	Not used	Not used	RRE1132	Not used	Not used	Not used	
	42	Operating Instructions (English/Spanish/Chinese)	Not used	Not used	Not used	Not used	RRE1130	RRE1130	RRE1130	
	45	Packing Case	RHG1717	RHG1717	RHG1758	RHG1716	RHG1719	RHG1718	RHG1718	
NSP	51	65 Label	ORW1069	ORW1069	Not used	Not used	Not used	Not used	Not used	
NSP	63	Fuse Caution Label	RRW-111	RRW-111	Not used	Not used	Not used	Not used	Not used	
NSP	64	Transformer 1 PCB	RNZ3046	RNZ3046	RNZ3041	RNZ3041	RNZ3041	Not used	Not used	
	64	Transformer 1 Unit	Not used	Not used	Not used	Not used	Not used	RWZ3731	RWZ3731	
$\Delta$	75	Line Voltage Selector (AC110/120-127/220/230-240V)	Not used	Not used	Not used	Not used	Not used	RSB1022	RSB1022	
	76	Insulator (Foot)	Not used	Not used	PNW1912	PNW1912	Not used	Not used	Not used	
	77	LED Lens Cover	Not used	Not used	RNK2206	RNK2206	Not used	Not used	Not used	
	78	Vinyl bag (115 x 270 x 0.05)	Not used	Not used	Z21-013	Not used	Not used	Not used	Not used	
	79	Spacer A	Not used	Not used	RHC1032	Not used	RHC1032	Not used	Not used	
	80	Spacer B	Not used	Not used	RHC1033	Not used	RHC1033	Not used	Not used	
	81	Caution Card	Not used	Not used	RRN1001	Not used	Not used	Not used	Not used	
	82	Caution 220V label	Not used	Not used	Not used	Not used	Not used	ARR1003	ARR1003	
$\Delta$	83	Fuse (T5A)	Not used	Not used	PEK1003	Not used	Not used	Not used	Not used	

# CT-W205R

## • Parts List for KUXJ type

Mark	No.	Description	Parts No.	Mark	No.	Description	Parts No.
	1	Main Unit	RWZ3930		51	65 Label	ORW1069
	2	Sub Unit	RWZ3931		52	Meter Panel	RAH2702
	3	.....			53	Slide Knob	REA1078
NSP	4	Transformer 2 Unit	RWZ3872		54	Screw	BSZ26P120FMC
Δ	5	Strain Relief	CM-22C		55	Bonnet	REA1077
Δ	6	Fuse (FU1, FU2, 1.25A)	REK1076		56	LED holder	RNK2194
Δ	7	AC Power Cord	PDG1015		57	.....	
	8	Lead Card 18P	RDD1355		58	Knob spacer	REC1195
Δ	9	Power Transformer	RTT1311		59	.....	
	10	1 Mechanism Unit	RYM1237		60	Eject Collar	RLA1283
	11	2 Mechanism Unit	RYM1238		61	.....	
	12	Rubber Sheet	AEB1111	NSP	62	Earth Lead Unit	DE015VF0
	13	Foot Assy	AEC1531	NSP	63	Fuse Caution Label	RRW-111
	14	Eject Spring L	RBH1379	NSP	64	Transformer 1 PCB	RNZ3046
	15	Door Spring L	RBH1304		65	.....	
	16	Door Spring R	RBH1305		66	.....	
	17	Half Pressure Spring	RBK1004		67	.....	
	18	Eject Spring R	RBH1380	NSP	68	PCB Spacer	PNY-404
	19	Damper Assy	REC1267	NSP	69	Chassis	RNB1100
NSP	20	Cord clamper	RNH1005		70	Connector Assy 3P	RKP1678
	21	.....			71	Connector Assy 5P	RKP1677
	22	.....		NSP	72	Binder	ZCA-T18S
	23	Eject Lever L	RNK2203		73	Eject Lever R	RNK2202
	24	Cord Clamper	RNH-184				
	25	Balance Knob	RAC1705				
	26	Eject Knob L	RAC1881				
	27	Eject Knob R	RAC1882				
	28	Power Knob	RAC1883				
	29	Control Knob	RAC1919				
	30	REC Knob B	RAC1788				
	31	Meter Lens	RAH2705				
	32	Front Panel	RAH2704				
	33	Door Pocket L	RAH2690				
	34	Door Pocket R	RAH2691				
	35	Door Lens	RAH2687				
	36	Name Plate	RAM1007				
	37	Remain Display Paper	REE-113				
	38	Rear Panel	RNA2050				
	39	Connection Cord with Mini Plug	PDE1267				
	40	Connection Cord Assy	RDE1036				
	41	Getter (PVC)	RAX1051				
	42	Operating Instructions (English)	RRB1169				
	43	Pad	RHA1115				
	44	Pad R	RHA1116				
	45	Packing Case	RHG1717				
	46	Sheet	Z23-007				
	47	LED Lens	PNW2019				
	48	Screw	BBZ30P060FMC				
	49	Screw	BBZ30P080FZK				
	50	Screw	IBZ30P150FCC				

### Packing

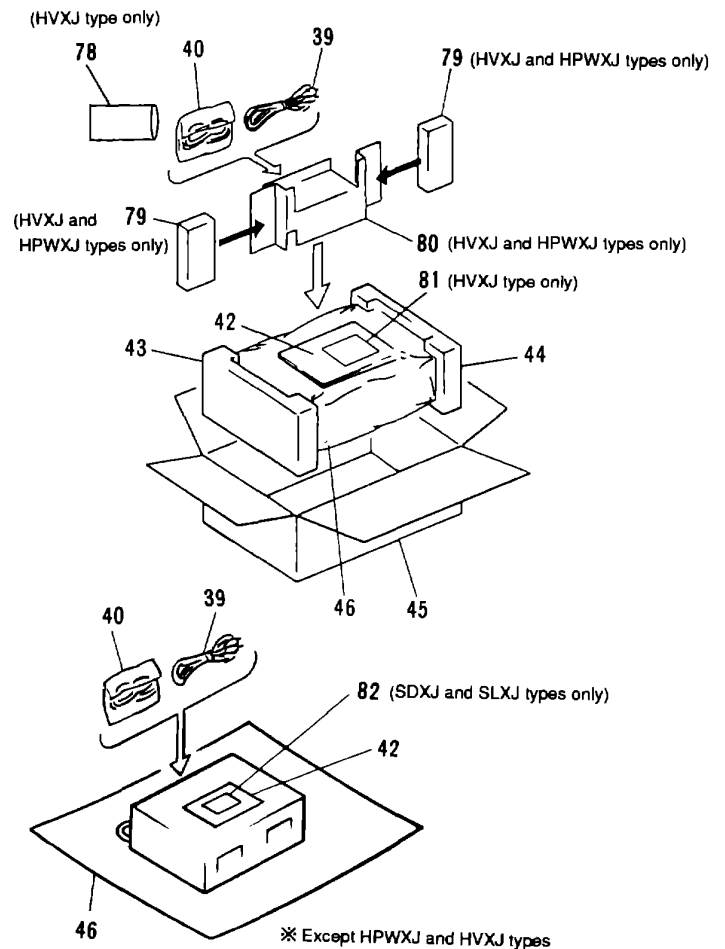



Exterior

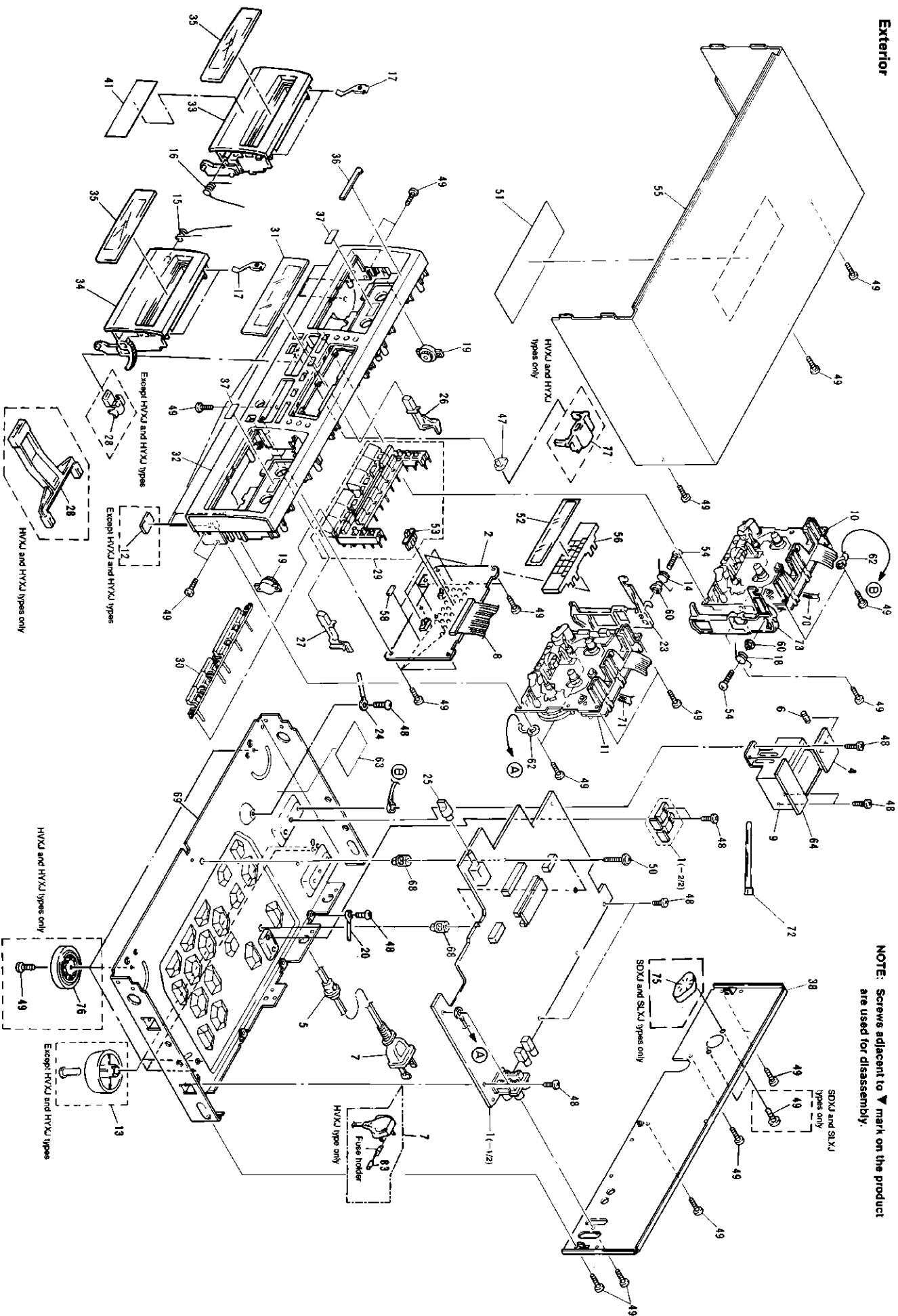

CT-W205R

2. 1 MECHANISM UNIT AND 2 MECHANISM UNIT

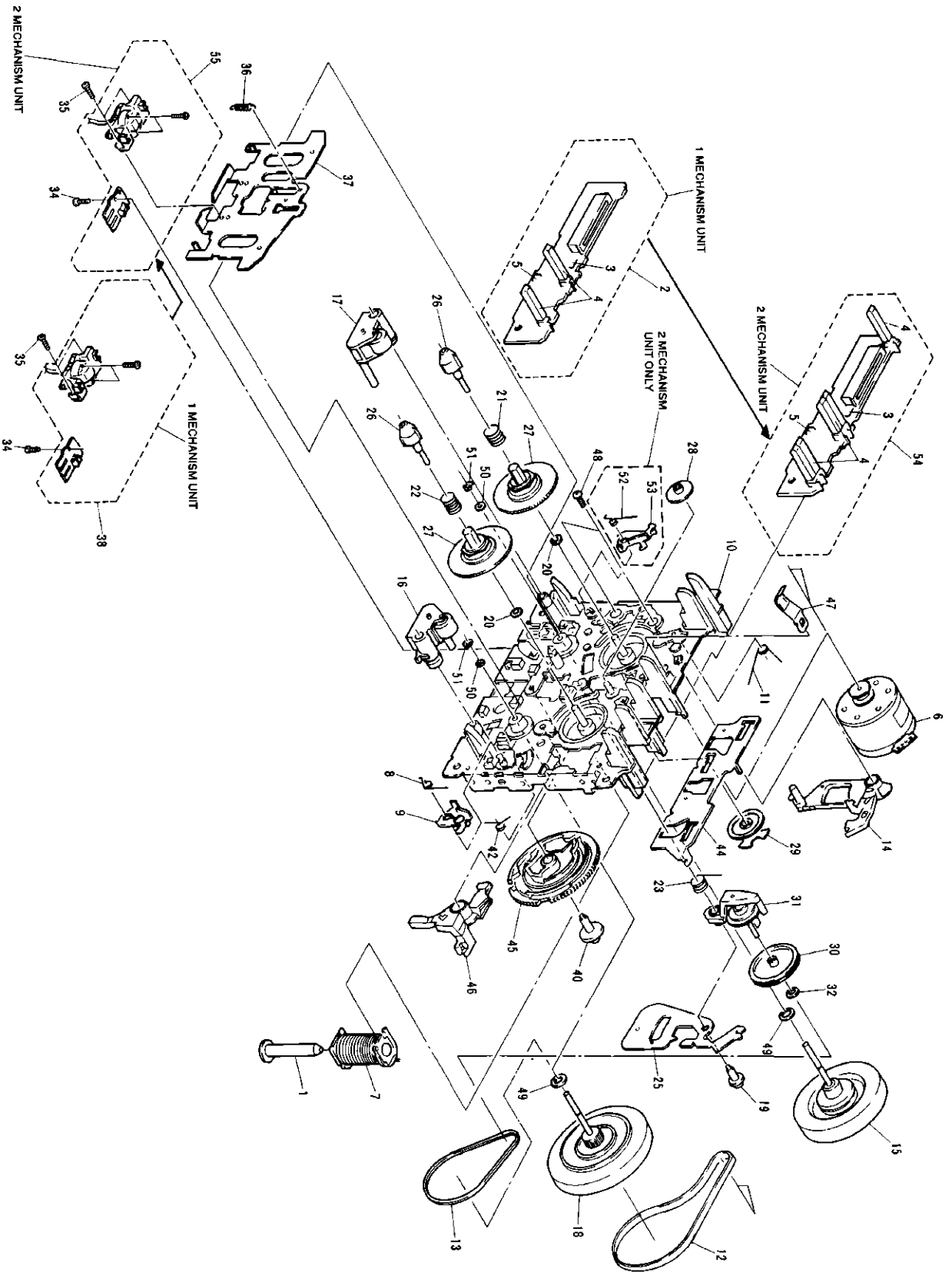

## Parts List

Mark	No.	Description	Part No.	Mark	No.	Description	Part No.
	1	PLUNGER	RLA1288	51	STOP RING	YE15FUC	
	2	PCB CONTROL BLK (1 MECHANISM UNIT)	RXA1623	52	SPRING INTERLOCK L (2 MECHANISM UNIT ONLY)	RBH1385	
	3	PUSH SWITCH	RSG1018	53	ARM INTERLOCK L (2 MECHANISM UNIT ONLY)	RNE1780	
	4	SPLF	RSN1023	54	PCB CONTROL BLK (2 MECHANISM UNIT)	RXA1733	
	5	PHOTO - TRANSISTOR	SPI33534FG	55	PLATE HD BLK (2 MECHANISM UNIT)	RXA1683	
	6	MTR MAIN BLK	RXM1081				
	7	SOLENOID BLK	RXP1021				
	8	SPRING INTERLOCK R	RBH1386				
	9	ARM INTERLOCK R	RNE1781				
	10	CHASSIS BASE BLK	RXA1626				
	11	SPRING BRAKE	RBH1387				
	12	MAIN BELT	REB1157				
	13	F/R BELT	REB1254				
	14	LEVER BRAKE	RNK2071				
	15	F/W ASSY	RXA1295				
	16	PINCH ROLLER BLK R	RXA1628				
	17	PINCH ROLLER BLK L	RXA1629				
	18	CLUTCH BLK ASSY	RXA1631				
	19	SCREW	RBA1120				
	20	WASHER	W41D065D025				
	21	SPRING REEL (L)	RBH1388				
	22	SPRING REEL (R)	RBH1389				
	23	CAM SPRING	RBH1393				
	24	.....					
	25	LEVER F/R	RNE1782				
	26	REEL FEATHER	RNK2072				
	27	REEL BASE	RNK2073				
	28	PLAY GEAR (A)	RNK2074				
	29	FF GEAR (A)	RNK2075				
	30	F/R PULLEY	RNK2076				
	31	CLUTCH BLK ASSY	RXA1632				
	32	WASHER	WA17D040D025				
	33	.....					
	34	SCREW	PCZ20P040FMC				
	35	SCREW	PMZ20P060FMC				
	36	SPRING HB	RBH1390				
	37	HEAD BASE	RNE1783				
	38	PLATE HD BLK (1 MECHANISM UNIT)	RXA1682				
	39	.....					
	40	SCREW	RBA1121				
	41	.....					
	42	SPRING ARM PLAY	RBH1392				
	43	.....					
	44	PLATE SLIDE	RNE1785				
	45	CAM GEAR	RNK2078				
	46	ARM PLAY	RNK2079				
	47	SPRING CASSETTE	RNE1786				
	48	SCREW	BMZ26P040FZK				
	49	WASHER	WA26D045D025				
	50	WASHER	WA26D047D050				

3. BLOCK DIAGRAM

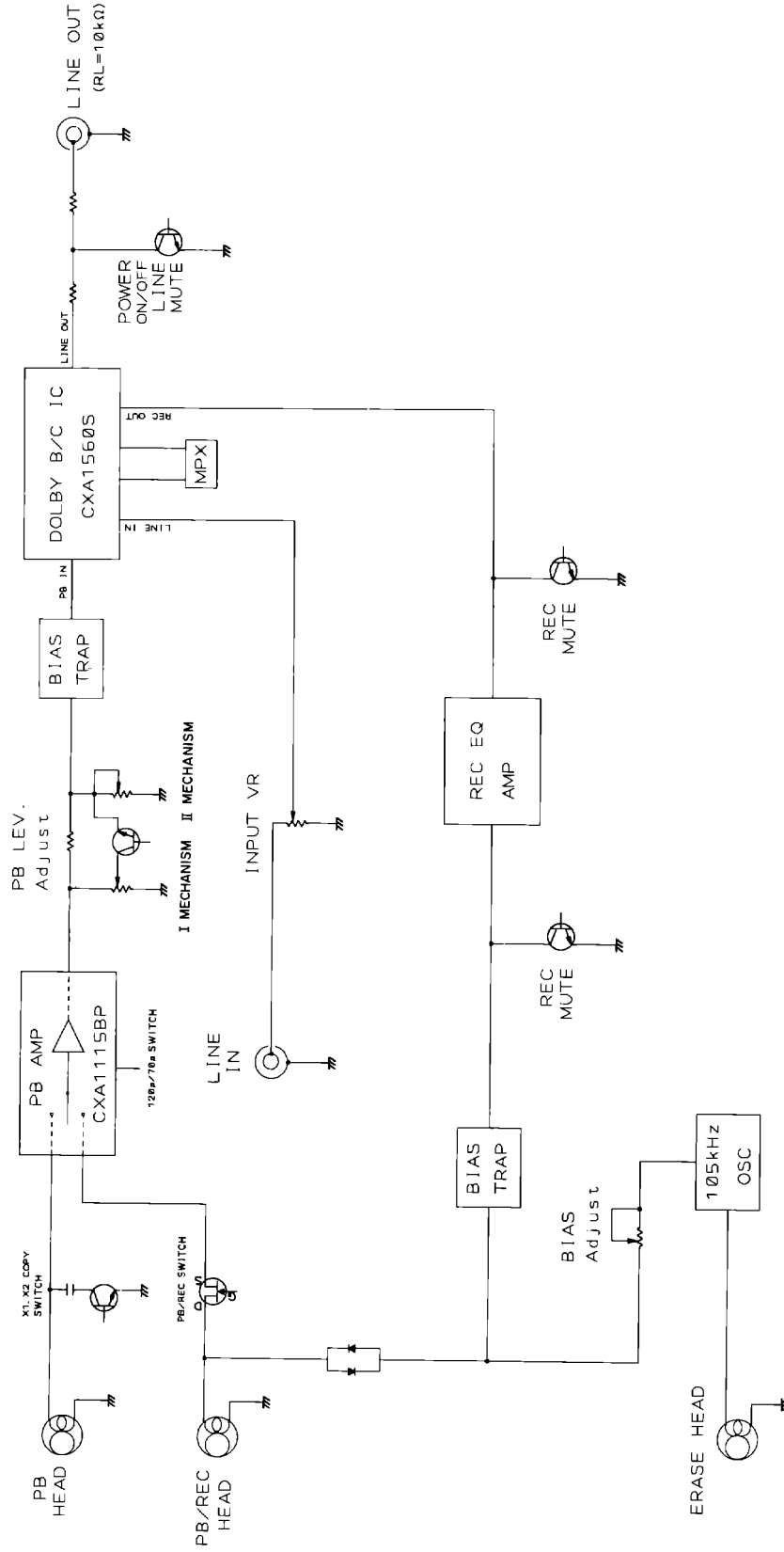

## 4. TEST MODE

### 4.1 Entering the Test Mode

STOP Mode

- Press the STOP key of deck I, MUTE, and PAUSE keys of deck II simultaneously to enter the test mode.

### 4.2 Exiting the Test Mode

- Press the STOP keys of deck 1 and deck 2 together. (Because the RESET key is not provided for this unit)
- Inputting the STANDBY Key (If the STANDBY key is available)
- Power OFF

The test mode can be exited by any one of the above.

### 4.3 Main Test Mode Items

- SW Check

#### 4.3.1 SW Operation Check

SW operations are as follows in the test mode.

Display	Input Key	Check
-∞ goes off	All keys except REWIND AUTO PLAY	<ul style="list-style-type: none"> <li>• In this mode, the mechanism operates without the half.</li> <li>• SW check</li> </ul> When the switch is pressed, the level meter lights up or blinks as shown in Table 1, enabling switch operations to be checked.

Table 1

Meter	-15	-8	-3	0	+3
L ch	When DOLBY NR is set to B : Blinks quickly C : Blinks slowly		Lights up when the half switch of deck I is pressed.	Lights up when the CrO <sub>2</sub> switch of deck I is pressed.	When the REV mode is set to ⏮ : Blinks quickly ⏪ : Blinks slowly
R ch	Lights up when forward recording inhibit switch of deck II is pressed.	Lights up when the metal switch of deck II is pressed.	Lights up when the half switch of deck II is pressed.	Lights up when the CrO <sub>2</sub> switch of deck II is pressed.	Lights up when reverse recording inhibit switch of deck II is pressed.

#### 4.3.2 x2 Speed Check

In the test mode, play the unit and complete assist operations (to stabilize mechanism operations), and then press ff or rew to set x2 speed play.

Press PLAY again to set normal speed play.

## 5. ADJUSTMENTS (調整方法)

### 1. MECHANICAL ADJUSTMENT (機構系の調整)

#### 1.1 Door Damping Check and Adjustment (ドアダンブ確認および調整)

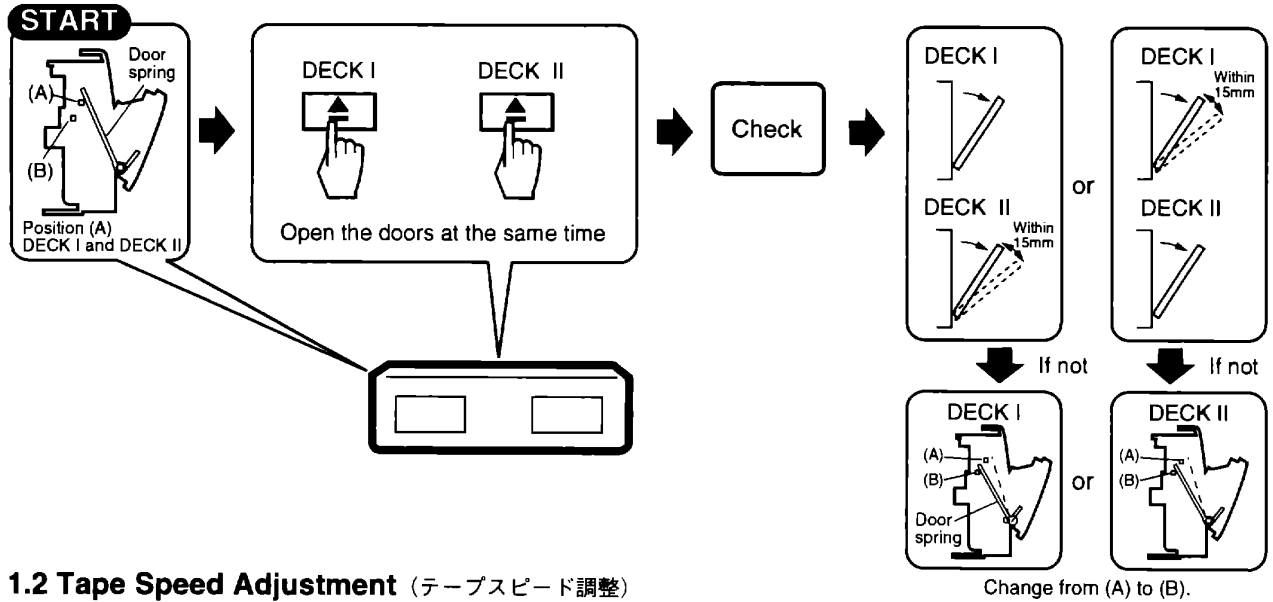

#### 1.2 Tape Speed Adjustment (テープスピード調整)

##### TEST MODE: ON

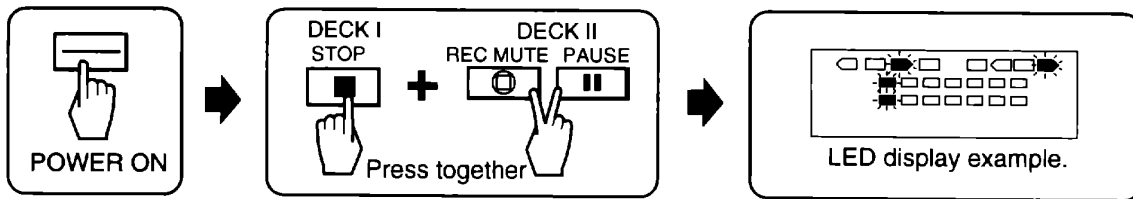

##### TEST MODE: DOUBLE SPEED PLAY

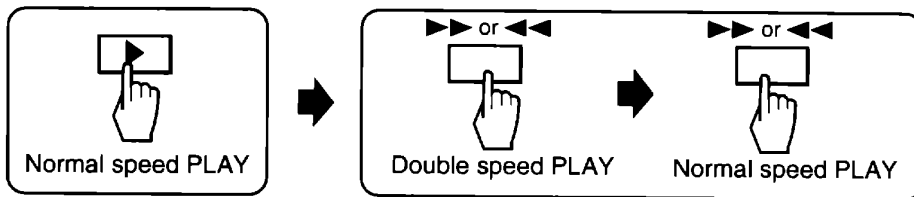

##### TEST MODE: STOP - CANCEL

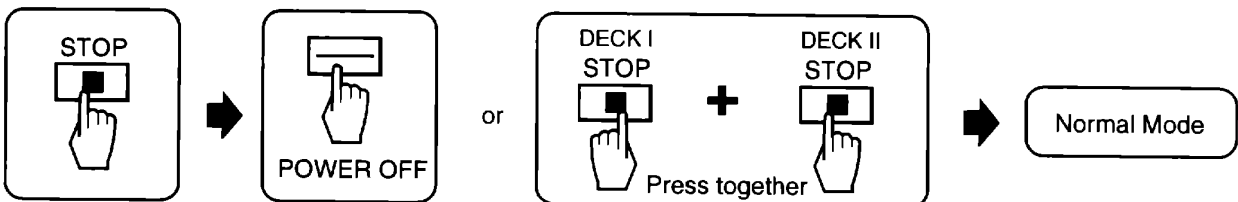

① Double speed PLAY  
(倍速PLAY)

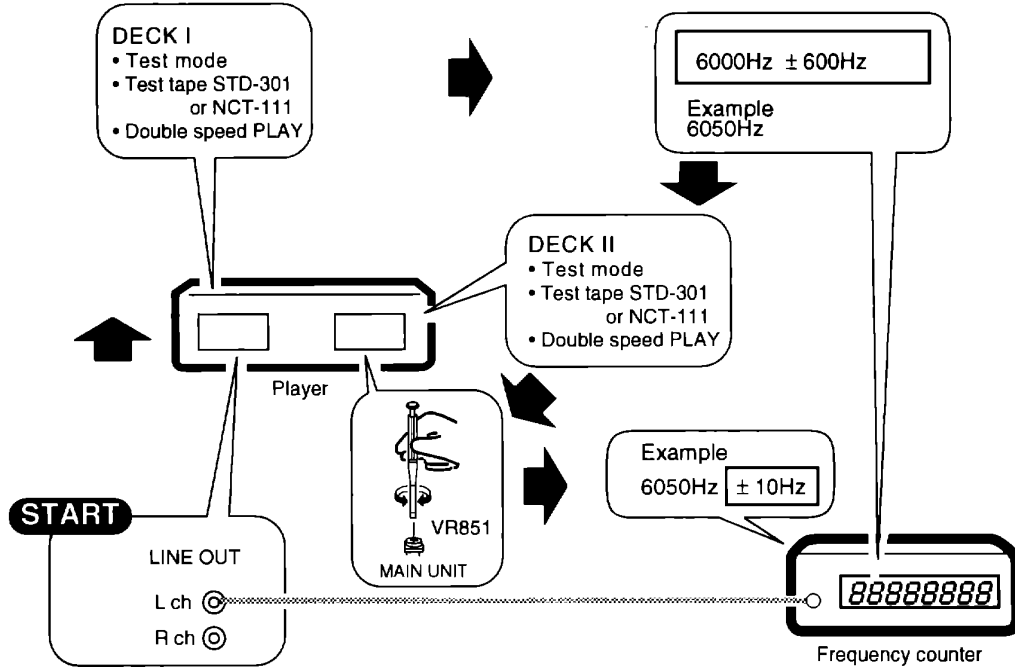

② Normal speed PLAY  
(定速PLAY)

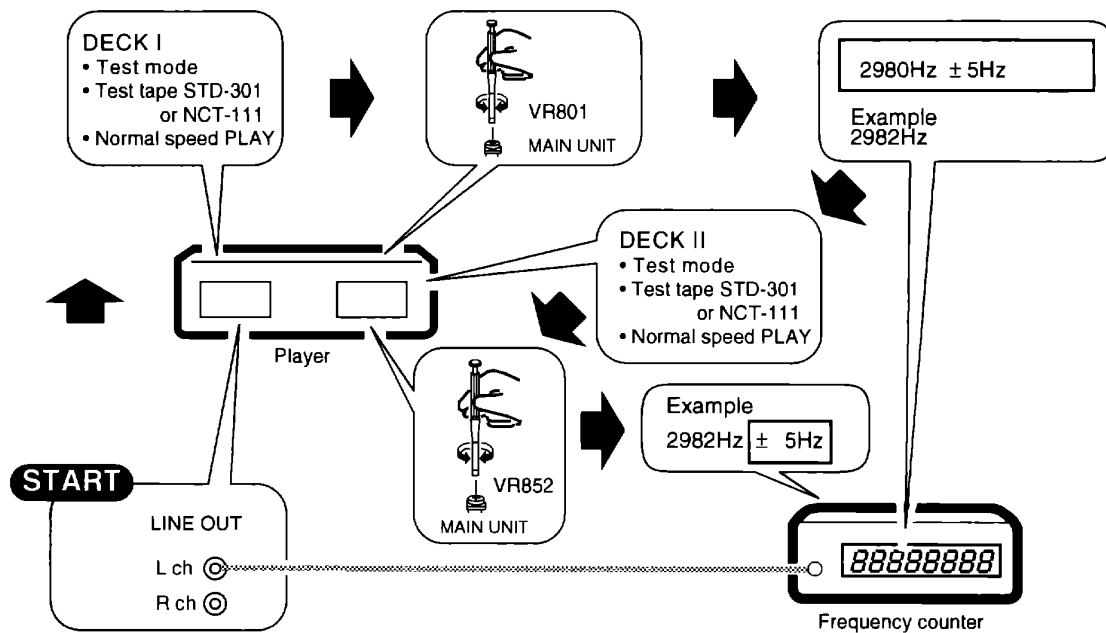

# CT-W205R

## 2. ELECTRICAL ADJUSTMENT (電気系の調整)

### Adjustment Conditions (調整条件)

1. The mechanical adjustments must be completed first.  
(メカ系の調整が完了していること。)
  2. The head must be cleaned and demagnetized.  
(ヘッドの清掃と消磁が行われていること。)
  3. Turn power on allow the deck to warm up for at least a few minutes before commencing any electrical adjustments.  
(調整の前に、セットを数分間エージングすること。)
  4. The reference signal is 0 dBV=1Vrms.  
(信号レベルは、0dBV=1Vrmsとする。)
  5. Connect a 10 kΩ load resistance to the OUTPUT terminals.  
(ライン出力端子に10kΩの負荷抵抗を接続する。)
  6. Unless otherwise specified, the switches listed below are left in the positions indicated.  
(特に指定のない場合は全てDOLBY NRスイッチOFFとする。)
- DOLBY NR : OFF  
TAPE SELECTOR : NORM

NOTE : This unit has an automatic tape selection feature.

オートテープセレクター機構付です

*Dolby noise reduction and HX Pro headroom extension manufactured under license from Dolby Laboratories Licensing Corporation. HX Pro originated by Bang & Olufsen. "DOLBY", the double-D symbol and "HX PRO" are trademarks of Dolby Laboratories Licensing Corporation.*

ドルビーノイズリダクション及びHX PROヘッドルームエクステンションはドルビーラボラトリーズライセンシングコーポレーションからの実施権に基づき製造されています。HX PROはバングアンドオルフセンの考案です。ドルビー、DOLBY、ダブルD記号及びHX PROはドルビーラボラトリーズライセンシングコーポレーションの商標です。

\* As the reference recording level is 250 nwb/m for STD-331E, the recording level will be higher by 4 dB for STD-331B (160 nwb/m). When adjusting, pay carefull attention to the type of tape used.

\* STD-331Eは、基準録音レベルが250nwb/mとなっており、STD-331B(160nwb/m)に対して、4dB録音レベルが高くなっています。調整時には、テープの種類に十分注意して下さい。

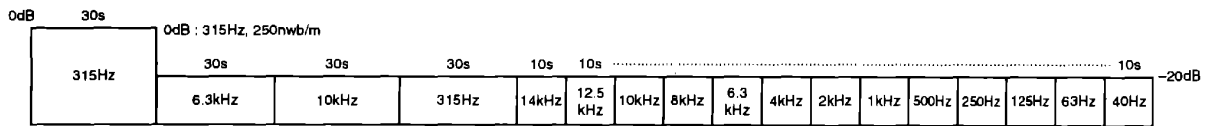
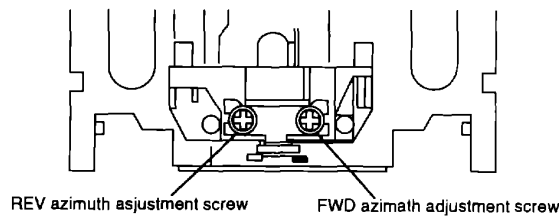
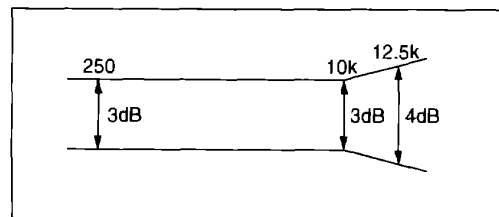

Fig. 1 Test tape STD-331E

### DECK I



### PLAY BACK



### DECK II

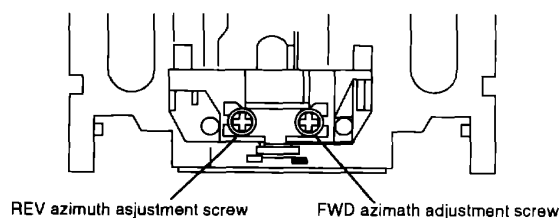

### RECORDING

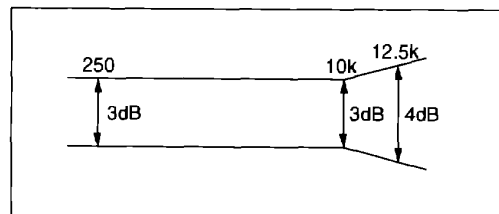

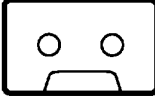
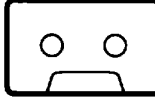





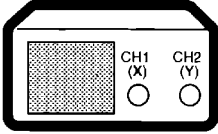
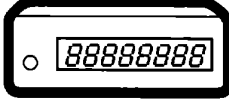

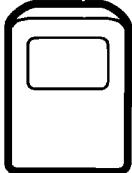
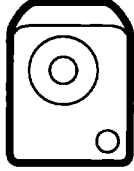
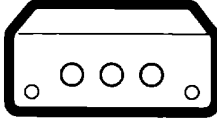

Fig.2 Head azimuth adjustment

Fig.3 Frequency response zone



**JIGS AND MEASURING INSTRUMENTS** (調整に必要な治工具類)

 Test tape (STD-331E)	 Test tape (STD-631 or STD-632) (Normal blank tape)	 Test tape (STD-622) (CrO <sub>2</sub> blank tape)	 Test tape (STD-611) (Metal blank tape)
 ⊖ Screwdriver (medium)	 ⊖ Screwdriver (small)	 ⊖ Precise screwdriver	 ⊕ Screwdriver (medium)
 ⊕ Screwdriver (large)	 Dual-trace oscilloscope	 Frequency counter	 10kΩ Load resistance
 AC millivoltmeter	 Low-frequency oscillator	 Attenuator	

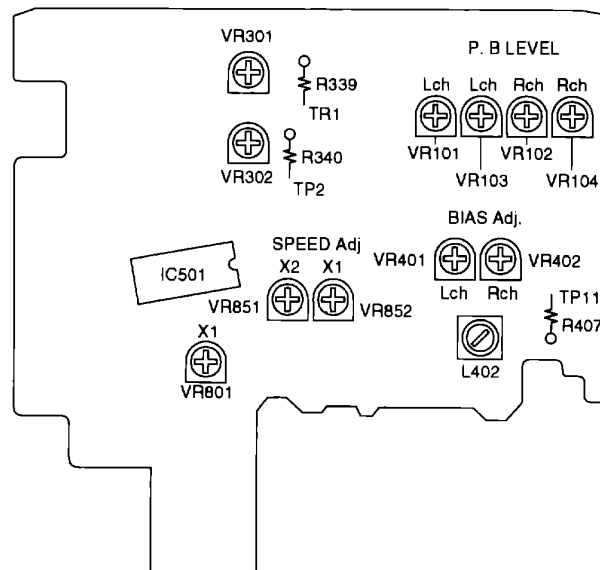
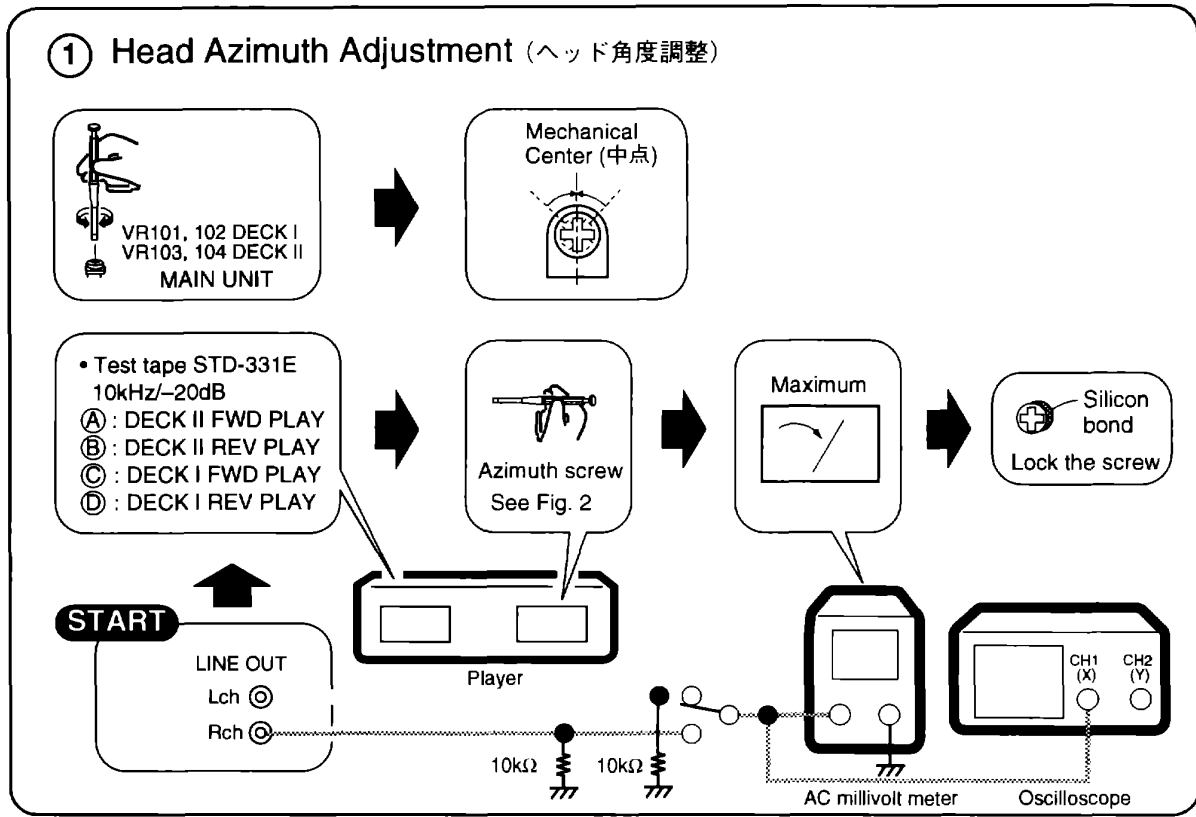

Fig.4 Adjustment points

## 2.1 Playback Section (再生系)

### ① Head Azimuth Adjustment (ヘッド角度調整)



### ② Playback Level Adjustment (再生レベル調整)

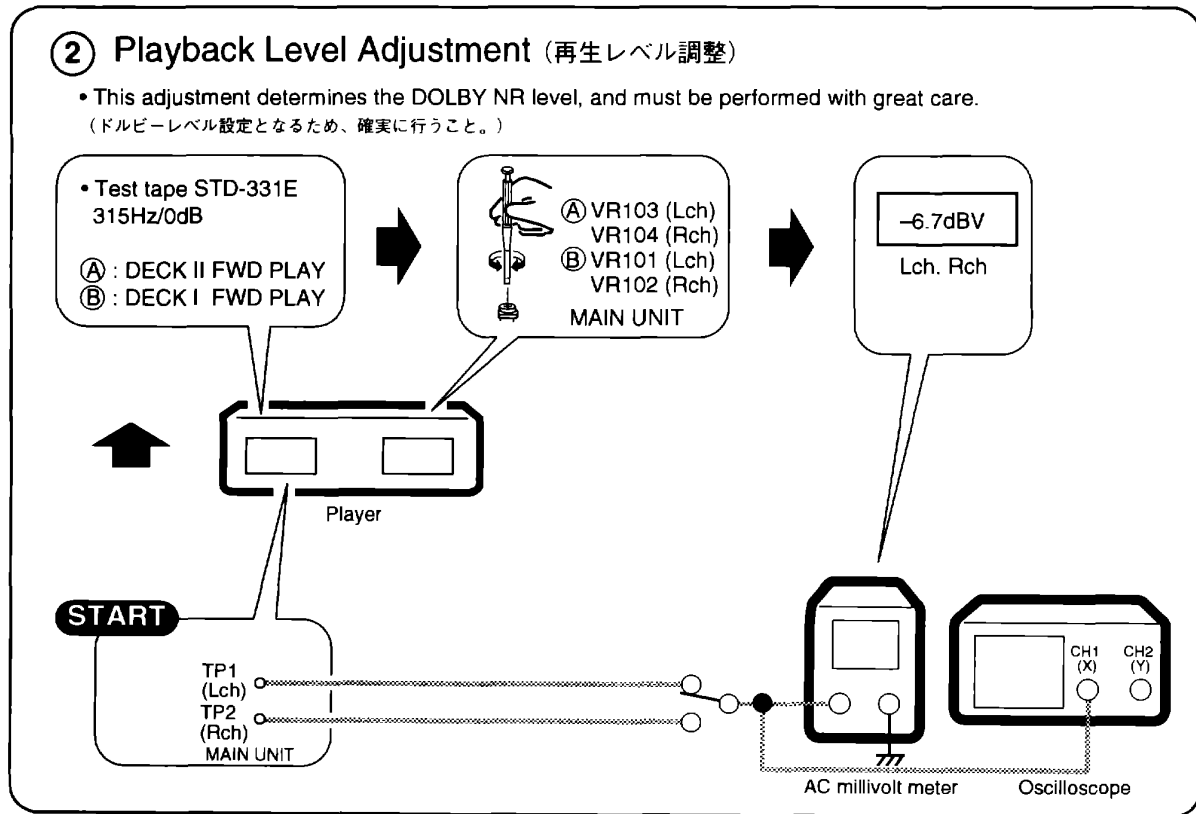

2.2 Recording Section (録音系)

① Bias Oscillator Adjustment (バイアス発振周波数調整)

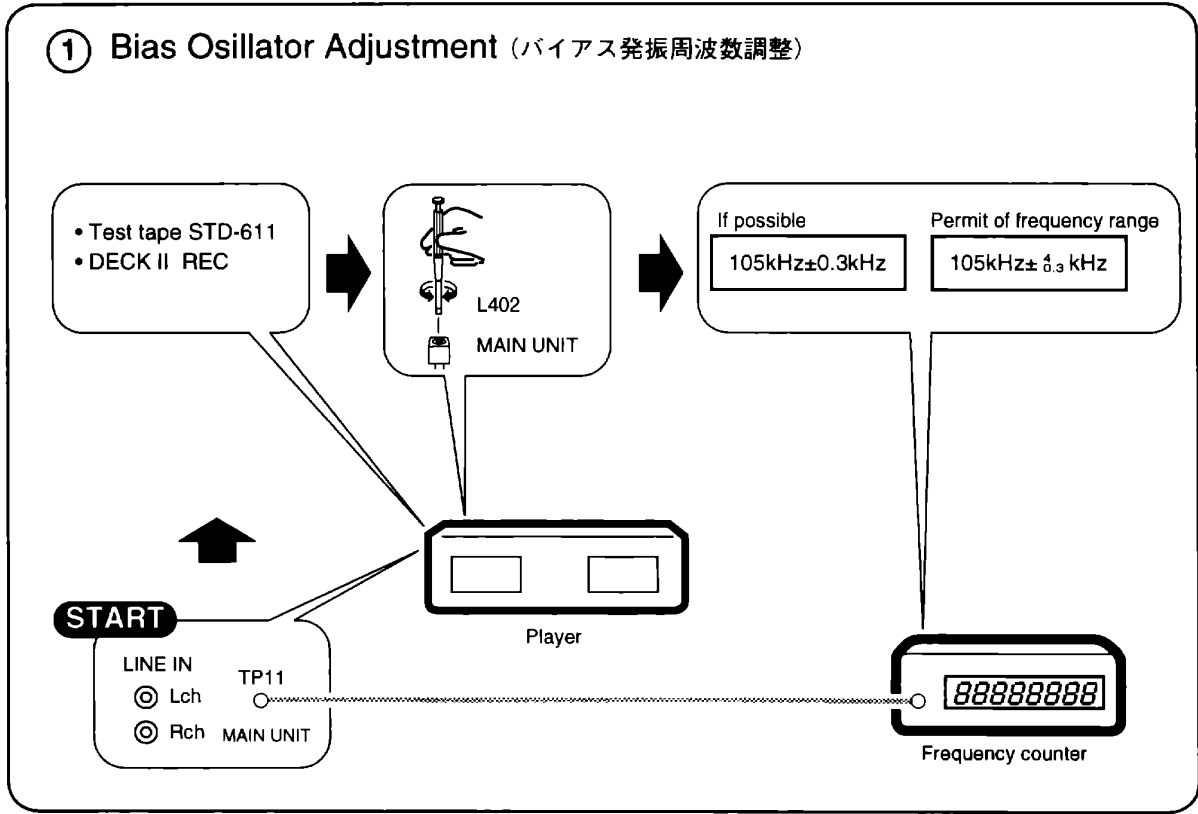

② Recording Bias Adjustment (録音バイアス調整)

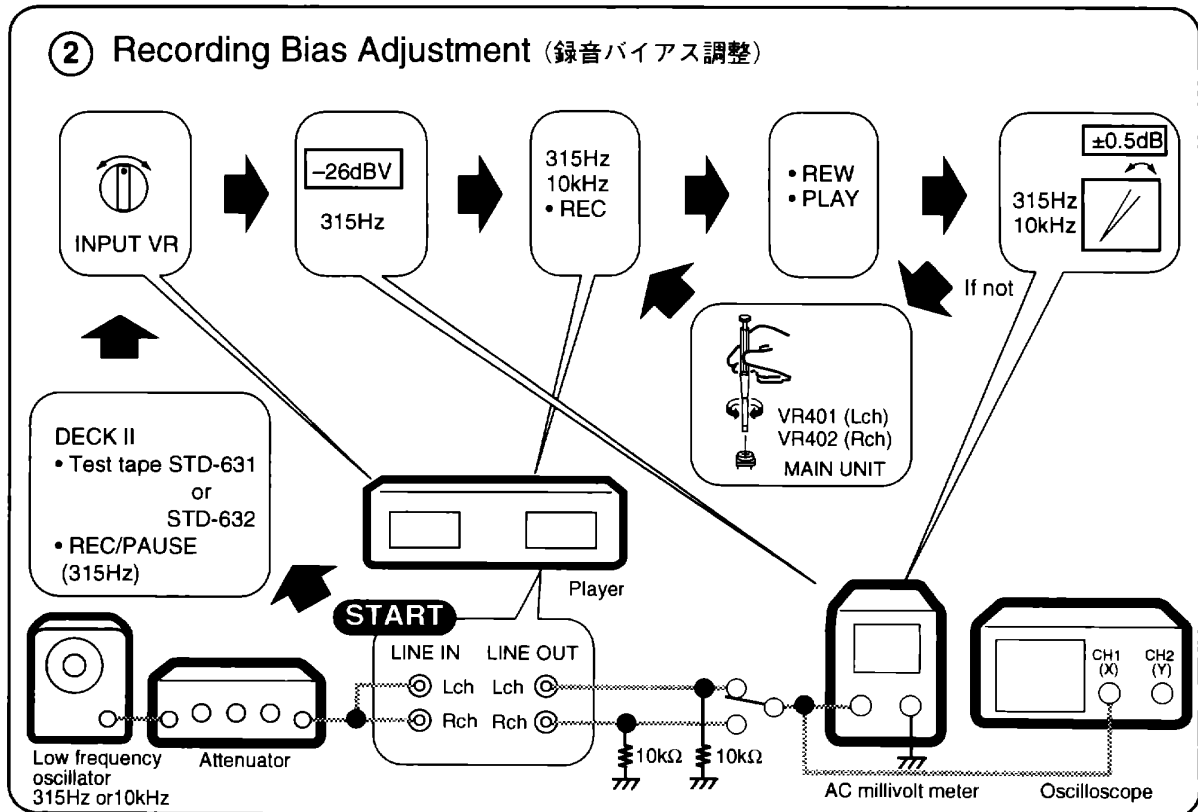

③ Recording Level Adjustment (録音レベル調整)

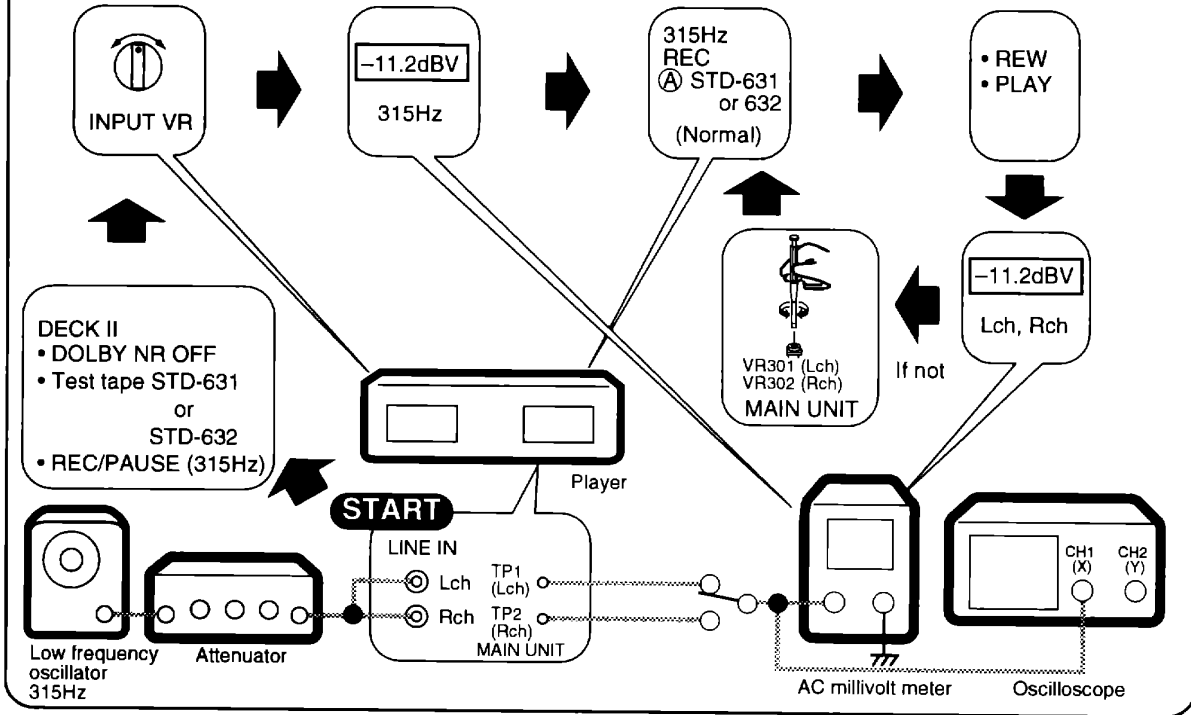

④ Recording Level Check (録音レベル確認)

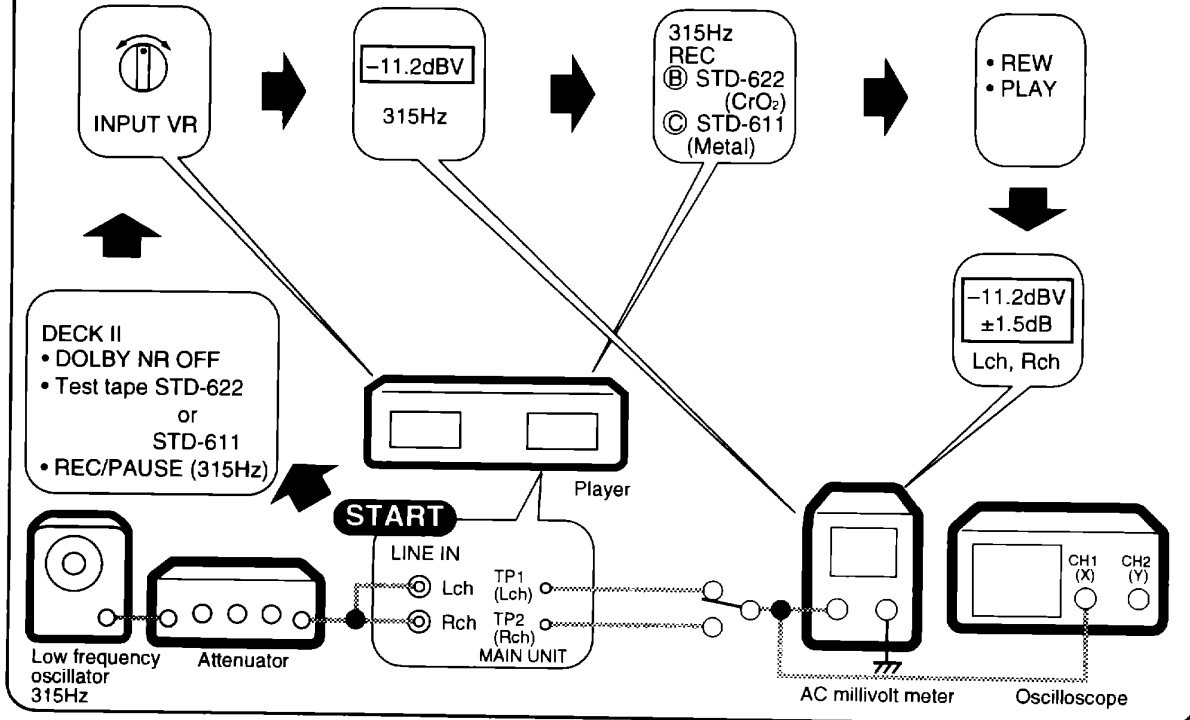



- Line voltage can be changed by the following modification:
1. Disconnect the power cord
  2. Remove the cover
  3. Change the interlocking wiring at follows
- | Voltage | Terminal No. | Terminal No. |
|---------|--------------|--------------|
| 220V    | RED WIRE     | GRAY WIRE    |
| 240V    | GRAY WIRE    | RED WIRE     |
4. Switch line voltage lead onto the rear panel.
- | Order   | Description |
|---------|-------------|
| AAA-118 | 220V/100A   |
| AAA-119 | 240V/100A   |
| AAA-122 | 240V/100A   |

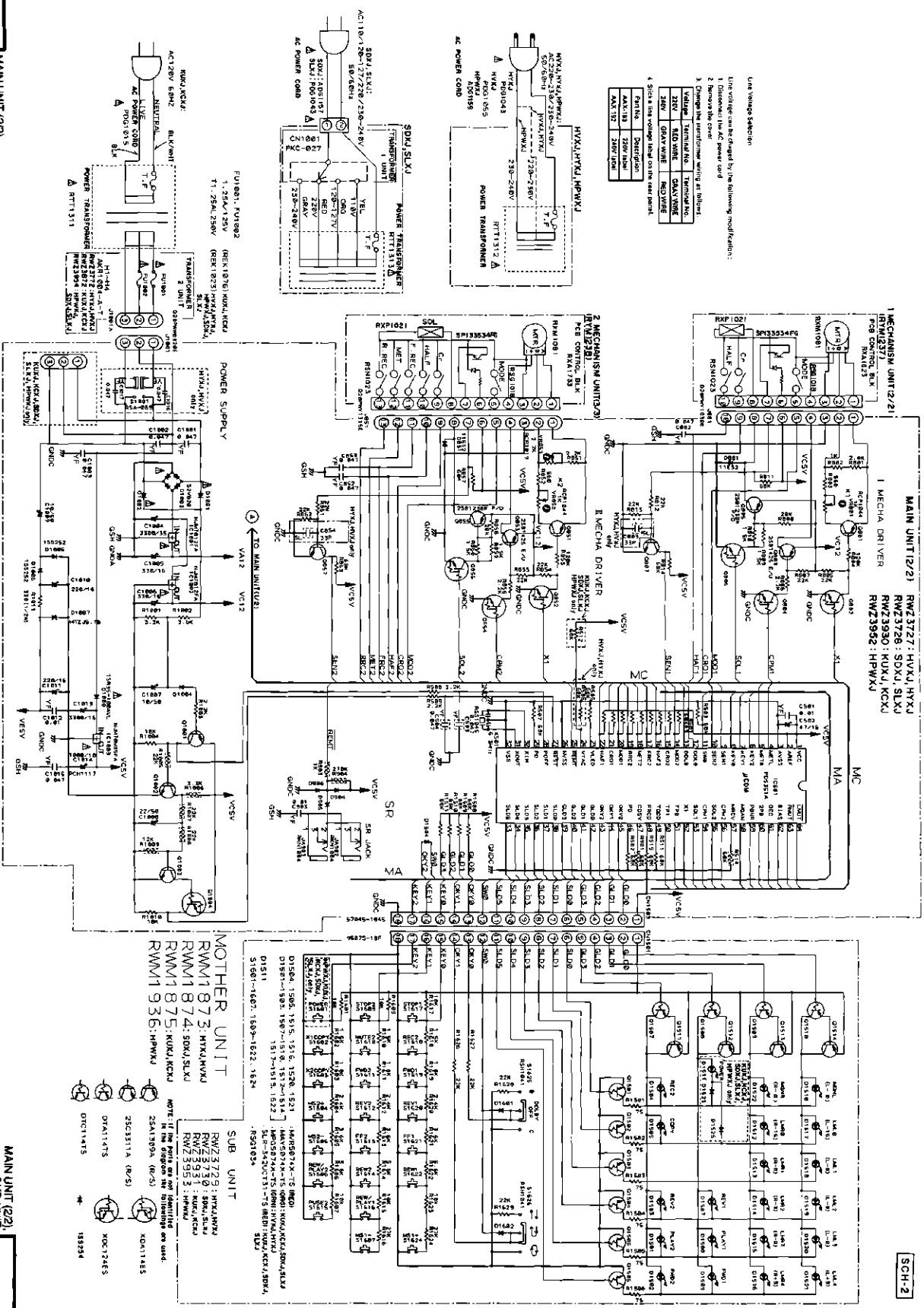



**8. PCB PARTS LIST**

**NOTES:**

- Parts marked by "NSP" are generally unavailable because they are not in our Master Spare Parts List.
- The  $\Delta$  mark found on some component parts indicates the importance of the safety factor of the part. Therefore, when replacing, be sure to use parts of identical designation.
- Parts marked by "⊙" are not always kept in stock. Their delivery time may be longer than usual or they may be unavailable.
- When ordering resistors, first convert resistance values into code form as shown in the following examples.

Ex.1 When there are 2 effective digits (any digit apart from 0), such as 560 ohm and 47K ohm (tolerance is shown by J=5%, and K=10%).

560  $\Omega$   $\rightarrow$  56  $\times 10^1 \rightarrow$  561 .....RD1/4PU **561 J**  
 47 k $\Omega$   $\rightarrow$  47  $\times 10^3 \rightarrow$  473 .....RD1/4PU **473 J**  
 0.5  $\Omega$   $\rightarrow$  0R5 .....RN2H **0R5 K**  
 1  $\Omega$   $\rightarrow$  1R0 .....RS1P **1R0 K**

Ex.2 When there are 3 effective digits (such as in high precision metal film resistors).

5.62 k $\Omega$   $\rightarrow$  562  $\times 10^1 \rightarrow$  5621 .....RN1/4PC **5621 F**

**■ LIST OF WHOLE PCB ASSEMBLIES**

Mark	PCB Assemblies	Part No.							Remarks
		KUXJ type	KCXJ type	HVXJ type	HYXJ type	HPWXJ type	SDXJ type	SLXJ type	
NSP	MOTHER UNIT	RWM1875	RWM1875	RWM1873	RWM1873	RWM1936	RWM1874	RWM1874	
NSP	— TRANSFORMER 2 UNIT	RWZ3872	RWZ3872	RWZ3732	RWZ3732	RWZ3954	RWZ3954	RWZ3954	
	— MAIN UNIT	RWZ3930	RWZ3930	RWZ3727	RWZ3727	RWZ3952	RWZ3728	RWZ3728	
	— SUB UNIT	RWZ3931	RWZ3931	RWZ3729	RWZ3729	RWZ3953	RWZ3730	RWZ3730	
NSP	— TRANSFORMER 1 UNIT	Not used	Not used	Not used	Not used	Not used	RWZ3731	RWZ3731	

**■ CONTRAST OF PCB ASSEMBLIES**

**TRANSFORMER 2 UNIT**

TRANSFORMER 2 UNIT has no service part.

**MAIN UNIT**

- Although RWZ3930, RWZ3952 and RWZ3728 are different in part number, they consist of the same components.
- RWZ3930 and RWZ3727 have the same construction except for the following:

Mark	Symbol & Description	Part No.		Remarks
		RWZ3930	RWZ3727	
	F101-F104, F203, F204	Not used	DTF1067	
	S1001	Not used	RSA-069	
	C221, C222	Not used	CCCSL101J50	
	C714	Not used	CCCSL470J50	
	C803, C854	Not used	CCSQL330J50	
	C1016, C1017	Not used	CKCYF473Z50	
	R131-R134, R231, R232	RS1/10S000J	Not Used	
	R506	Not Used	RD1/6PM683J	
	R512	RD1/6PM683J	Not Used	



## SUB UNIT

- Although RWZ3931, RWZ3953 and RWZ3730 are different in part number, they consist of the same components.
- RWZ3931 and RWZ3729 have the same construction except for the following:

Mark	Symbol & Description	Part No.		Remarks
		RWZ3931	RWZ3729	
	D1501-D1503, D1507-D1510, D1512-D1514, D1517-D1519, D1522 D1511 D1523, D1525 S1601	MAY5074X  SLR-342UCT31 1SS254 RSG1034	MPG5074X  Not Used Not Used Not Used	

## TRANSFORMER 1 UNIT

TRANSFORMER 1 UNIT has no service part.

## ■ PARTS LIST FOR KUXJ TYPE

Mark	No.	Description	Parts No.	Mark	No.	Description	Parts No.
<b>TRANSFORMER 2 UNIT</b>				△	D1007		MTZJ5.1B
TRANSFORMER 2 UNIT has no service part.				△	D1003		S2VB20
<b>MAIN UNIT</b>				<b>COILS AND FILTERS</b>			
<b>SEMICONDUCTORS</b>					L401		LFA121K
	IC101		CXA1115BP		L402		RTD1077
	IC201		CXA1560S		L101, L102		RTF1099
△	IC1001, IC1002		NJM7812FA		L301, L302		RTF1102
△	IC1003		NJM78M05FA		L303, L304		RTF1125
	IC501		PD5351A		F201, F202		RTF1208
	IC301, IC651, IC701		XRA15218	<b>CAPACITORS</b>			
	Q1001, Q801, Q851		2SA1309A		C405, C406		CCCSL101K500
	Q404, Q405, Q805, Q855		2SB1238X		C161, C162		CCSQCH100D50
	Q803, Q853		2SB1425		C109-C112, C701, C702		CCSQSL101J50
	Q401, Q402		2SC1815		C709-C712		CCSQSL101J50
	Q1002, Q1003, Q807, Q857		2SC3311A		C803, C854		CCSQSL330J50
	Q403		2SD1302		C107, C108		CEANL101M10
	Q311, Q312, Q701, Q702		2SD2144S		C201, C202, C213, C214		CEAS010M50
	Q161, Q162		2SK373		C321, C322, C703, C704		CEAS010M50
	Q502, Q751		DTA114TS		C1007, C1009, C211, C212		CEAS100M50
	Q105, Q106, Q163, Q164		DTC114TS		C217, C218, C317, C318		CEAS100M50
	Q309, Q310, Q406, Q407		DTC114TS		C707, C708		CEAS100M50
	Q651, Q652		DTC114TS		C220		CEAS101M16
	Q103, Q104		DTC115TS		C1008		CEAS220M50
	Q1004, Q165		XDA114ES		C1010, C1011		CEAS221M16
	Q101, Q102, Q166, Q201-Q203		XDC124ES		C403, C404		CEAS330M16
	Q301-Q308, Q313, Q802, Q804		XDC124ES		C660		CEAS330M35
	Q806, Q852, Q854, Q856		XDC124ES		C1005, C1006		CEAS331M16
	D801, D851		11ES2		C659		CEAS331M6R3
△	D1008		ISR35-100AVL		C1013		CEAS332M16
	D1005, D1006		1SS252		C1004		CEAS332M35
△	D1001, D1002, D1004		1SS254		C653, C654		CEAS3R3M50
△	D1604, D161-D166, D651-D653		1SS254		C125, C126, C219, C323, C325		CEAS470M16
	D904-D906		1SS254		C409, C502, C705, C713		CEAS470M16
	D751		MTZJ3.9B		C115, C116, C313, C314		CEAS4R7M50
					C315, C316		CEASR22M50

Mark	No.	Description	Parts No.
C657, C658			CEASR47M50
C407			CFTXA123J50
C113, C114			CFTXA822J50
C215, C216			CFTYA103J50
C207, C208			CFTYA104J50
C209, C210			CFTYA683J50
C1012, C501, C903			CKCYF103Z50
C1001-C1003, C1015-C1017, C326			CKCYF473Z50
C651, C652, C706, C751, C802			CKCYF473Z50
C852, C853			CKCYF473Z50
C655, C656			CKSQYB122K50
C305, C306			CKSQYB123K50
C307, C308			CKSQYB153K50
C117, C118			CKSQYB183K50
C301, C302			CKSQYB221K50
C309, C310			CKSQYB272K50
C101-C104			CKSQYB331K50
C303, C304, C319, C320			CKSQYB332K50
C123, C124			CKSQYB391K50
C311, C312			CKSQYB392K50
C401, C402			CKSQYB472K50
C105, C106, C121, C122			CKSQYB681K50
C408			CKSQYB682K50
C128			CKSQYF103Z50
C503, C504			CKSQYF473Z50
C410			CQPA822J100
C1014 (1000 $\mu$ F/10V)			PCH1117
<b>RESISTORS</b>			
R501			RA9T683J
R339, R340 (4.7k $\Omega$ )			RCN1028
R407			RD1/2LMF010J
R414			RD1/2LMF150J
R410			RD1/2LMF181J
R409			RD1/2LMF201J
R1011			RD1/2LMF331J
R408			RD1/2LMF4R7J
R305, R306, R411, R413, R802			RD1/6PM102J
R1004, R1010, R123, R401, R402			RD1/6PM103J
R751			RD1/6PM103J
R121, R343, R753			RD1/6PM104J
R804, R853			RD1/6PM124J
R107, R108			RD1/6PM151J
R809, R810, R859, R860			RD1/6PM152J
R111, R112			RD1/6PM163J
R207			RD1/6PM182J
R319, R320			RD1/6PM183J
R808, R858			RD1/6PM203J
R1003, R117, R118, R122, R208			RD1/6PM222J
R341, R405, R406, R508, R509			RD1/6PM222J
R806, R851, R856			RD1/6PM222J
R342, R403, R404, R805, R807			RD1/6PM223J
R812, R813, R854, R855			RD1/6PM223J
R861, R862			RD1/6PM223J
R801			RD1/6PM242J
R124			RD1/6PM271J

Mark	No.	Description	Parts No.
R311, R312			RD1/6PM272J
R109, R110, R329, R330			RD1/6PM273J
R115, R116, R203, R204			RD1/6PM302J
R1001, R307, R308, R338			RD1/6PM332J
R101, R102			RD1/6PM334J
R1002, R321, R322, R717, R718			RD1/6PM362J
R163, R317, R318, R412			RD1/6PM473J
R315, R316, R803, R852			RD1/6PM561J
R325, R326			RD1/6PM562J
R653, R654, R752			RD1/6PM681J
R120, R331-R334			RD1/6PM682J
R1508-R1511, R323, R324			RD1/6PM683J
R502, R503, R505, R511, R512			RD1/6PM683J
R515, R811, R814, R857, R863			RD1/6PM683J
R313, R314			RD1/6PM822J
R335, R336			RD1/6PM911J
R301, R302, R309, R310			RD1/6PM912J
VR851 (2.2k $\Omega$ )			RCP1019
VR801, VR852 (1.0k $\Omega$ )			RCP1044
VR301, VR302 (22k $\Omega$ )			RCP1046
VR101-VR104 (47k $\Omega$ )			RCP1047
VR401, VR402 (100k $\Omega$ )			RCP1048
VR701 (5k $\Omega$ )			RCV1089
Other Resistors			RS1/10S□□□J

#### OTHERS

CN1503	18P CONNECTOR	52045-1845
CN401	CONNECTOR POST	B2B-PH-K-S
CN101, CN102	CONNECTOR POST 3P	B3B-PH-K-S
JA701	4P PIN JACK	RKB-020
JA902, JA903	REMOTE CONTROL JACK	RKN1004
X501	CERAMIC RESONATOR	RSS1045
	PCB BINDER	VEF1040
	EARTH METAL FITTING	VNF-091

#### SUB UNIT

#### SEMICONDUCTORS

Q1511-Q1514	2SA1309A
Q1507-Q1510	DTA114TS
Q1501-Q1506	DTC114TS
D1523, D1525, D1601, D1602	1SS254
D1501-D1503, D1507-D1510	MAY5074X
D1512-D1514, D1517-D1519, D1522	MAY5074X
D1504, D1505, D1515, D1516	MVR5074X
D1520, D1521	MVR5074X
D1511	SLR-342UCT31

#### SWITCHES AND RELAYS

S1601-S1607, S1609-S1622, S1624	RSG1034
S1625, S1626	RSH1041

#### RESISTORS

All Resistors	RD1/6PM□□□J
---------------	-------------

#### OTHERS

CN1501	18P CONNECTOR	9607S-18F
--------	---------------	-----------

## 9. IC INFORMATION

• The information shown in the list is basic information and may not correspond exactly to that shown in the schematic diagrams.

### ■ PD5351A (MAIN UNIT: IC501) U-COM IC

#### ● Pin Arrangement (Top View)

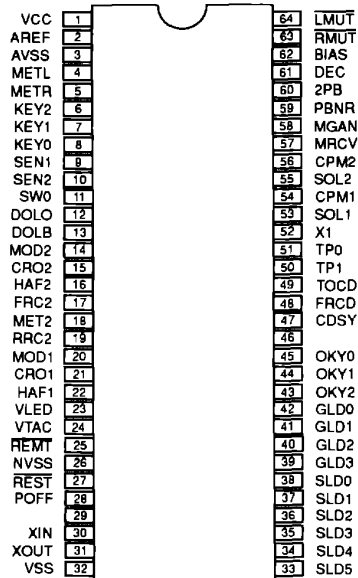

#### ● Pin Function

Pin No.	Name	I/O	Function
1	VCC	I	Power supply 5V
2	AREF	I	AREF is connected to 5V, AVSS is connected to GND.
3	AVSS	I	Power supply for the built-in A/D converter.
4	METL	I	Lch level meter input
5	METR	I	Rch level meter input
6	KEY2	I	Key scanning input (Key switch A/D input)
7	KEY1	I	
8	KEY0	I	
9	SEN1	I	Take-up side sensing pulse. Primary side input
10	SEN2	I	Take-up side sensing pulse. Secondary side input
11	SW0	I	Dolby NR SW, REVRS SW DC input
12	DOLO	O	Dolby NR control When Dolby NR OFF, DOLO: "H". When Dolby NR B, DOLB: "H".
13	DOLB	O	
14	MOD2	I	Mechanical SW input voltage "L" when all the following SWs are ON. Mode SW, chrome SW, half SW, forward record disable SW, metal SW, reverse record disable SW.
15	CRO2	I	
16	HAF2	I	
17	FRC2	I	
18	MET2	I	
19	RRC2	I	
20	MOD1	I	
21	CRO1	I	"L" when all the following SWs are ON. Mode SW, chrome SW, half SW.
22	HAF1	I	

# CT-W205R

Pin No.	Pin Name	I/O	Pin Function												
23	VLED	I	Power supply SW version select input												
			<table border="1"> <thead> <tr> <th></th> <th>POWER SW (tact) With LED</th> <th>POWER SW (mechanical) With LED</th> <th>Without LED</th> </tr> </thead> <tbody> <tr> <td>VTAC</td> <td>H</td> <td>L</td> <td>L</td> </tr> <tr> <td>VLED</td> <td>H or L</td> <td>H</td> <td>L</td> </tr> </tbody> </table>		POWER SW (tact) With LED	POWER SW (mechanical) With LED	Without LED	VTAC	H	L	L	VLED	H or L	H	L
	POWER SW (tact) With LED	POWER SW (mechanical) With LED	Without LED												
VTAC	H	L	L												
VLED	H or L	H	L												
24	VTAC	I	H: 5V L: GND												
25	REMT	I	Remote commander signal input												
26	NVSS	I	Chip operation mode control. Connected to GND.												
27	REST	O	Reset signal input. ("L" when reset.)												
28	POFF	I	Power off signal input. ("H" when power off.)												
29		O	Connected to a pull-down resistor.												
30	XIN	I	Connected to the main clock (6.3 MHz).												
31	XOUT	O													
32	VSS	I	Power supply GND												
33	SLD5	O	Display output (Soft scanning output)												
34	SLD4	O													
35	SLD3	O													
36	SLD2	O													
37	SLD1	O													
38	SLD0	O													
39	GLD3	O													
40	GLD2	O													
41	GLD1	O													
42	GLD0	O													
43	OKY2	O	Output for detecting Dolby NR SW, REVRS SW.												
44	OKY1	O													
45	OKY0	O													
46		O	Connected to a pull-down resistor.												
47	CDSY	I	CD SYNCHRO input/output												
48	FRCD	I	When SYNCHRO jack IN, "L" input. During CD play, "L" input.												
49	TOCD	O	When SYNCHRO REC, TOCD is output in "H".												
50	TP1	O	<table border="1"> <thead> <tr> <th></th> <th>NOR</th> <th>CRO</th> <th>MET</th> </tr> </thead> <tbody> <tr> <td>TP0</td> <td>L</td> <td>H</td> <td>L</td> </tr> <tr> <td>TP1</td> <td>L</td> <td>L</td> <td>H</td> </tr> </tbody> </table>		NOR	CRO	MET	TP0	L	H	L	TP1	L	L	H
	NOR	CRO		MET											
TP0	L	H	L												
TP1	L	L	H												
51	TP0	O	H: 5V L: GND												
52	X1	O	Motor speed adjustment. When X1 speed, "H".												
53	SOL1	O	Deck 1 side mechanical control output Solenoid control												
54	CPM1	O	Capstan motor control												
55	SOL2	O	Deck 2 side mechanical control output Solenoid control												
56	CPM2	O	Capstan motor control												
57	MRCV	O	Meter circuit recovery time control. (When recovery FAST, "H".)												
58	MGAN	O	Meter circuit gain select. (When MS, "H".)												
59	PBNR	O	When a normal tape is played back, "H" is output.												
60	2PB	O	When deck 2 is played back, "H" is output.												
61	DEC	O	DECODE/ENCODE output. When DECODE, "H". When ENCODE, "L".												
62	BIAS	O	Bias control. (When bias ON, "H".)												
63	RMUT	O	REC MUTE control. (When MUTE ON, "L".)												
64	LMUT	O	LINE MUTE control. (When MUTE ON, "L".)												

# 10. PANEL FACILITIES

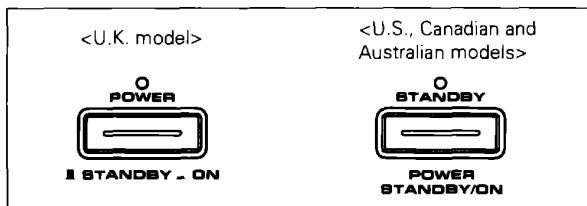
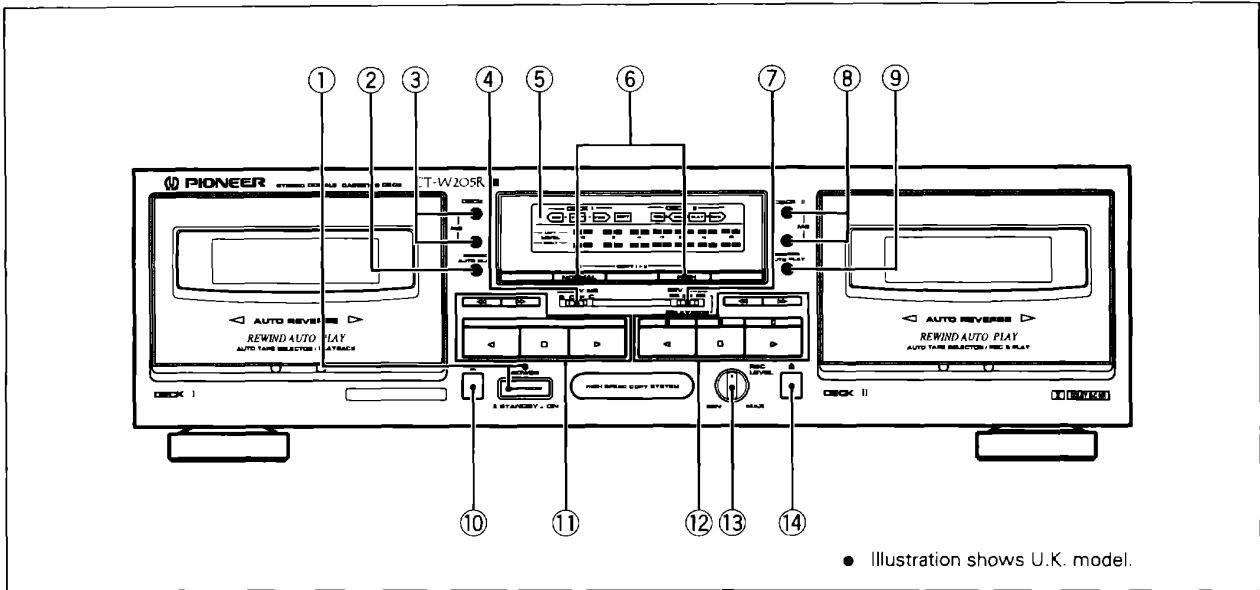

① **POWER (■STANDBY -ON) switch (U.K. model)**

**POWER STANDBY/ON switch (U.S., Canadian Australian models)**

The POWER switch activates the secondary transformer only. Even when the switch is in the STANDBY position, there will be a power flow to the deck's circuits as long as the power cord is connected to a power outlet. The indicator lights when the unit functions enter STANDBY, and it goes off when the power is turned on.

- ② **DECK I REWIND AUTO PLAY button**
- ③ **DECK I MS(music search) +,- buttons**
- ④ **DOLBY\* NR switch (B/OFF/C)**

\*  
 ● *Dolby noise reduction and manufactured under license from Dolby Laboratories Licensing Corporation.*  
 ● *"DOLBY", the double-D symbol are trademarks of Dolby Laboratories Licensing Corporation.*

- ⑤ **Function display**
- ⑥ **Synchro copy buttons (COPY I ► II)**  
 NORMAL: Normal speed copy  
 HIGH : Double speed copy
- ⑦ **Reverse mode switch (REV MODE RELAY/SKIP)**
- ⑧ **DECK II MS(music search) +,- buttons**
- ⑨ **DECK II REWIND AUTO PLAY button**

- ⑩ **DECK I eject button (▲)**  
 ● If the tape is moving (playback, tape winding, etc.), press the stop (■) button before pressing this button.

**NOTE:**  
 If the power is turned off while the tape is moving, the cassette door may remain locked. In this case, turn the power on before pressing the eject (▲) button.

- ⑪ **Deck I operation buttons**  
 ◀ : Reverse playback  
 ▶ : Forward playback  
 ◀◀ : Fast reverse  
 ■ : Stop  
 ▶▶ : Fast forward

- ⑫ **DECK II operation buttons**  
 ◀ : Reverse playback  
 ▶ : Forward playback  
 ◀◀ : Fast reverse  
 ■ : Stop  
 ▶▶ : Fast forward  
 ○ : Recording mute  
 II : Pause  
 ● : Recording

- ⑬ **Recording level control (REC LEVEL)**

- ⑭ **DECK II eject button (▲)**  
 ● If the tape is moving (recording, playback, tape winding, etc.), press the stop (■) button before pressing this button.

**NOTE:**  
 If the power is turned off while the tape is moving, the cassette door may remain locked. In this case, turn the power on before pressing the eject (▲) button.

# CT-W205R

## 11. SPECIFICATIONS

System .....	4-track, 2-channel stereo
Heads "Hard Permalloy" recording/playback head x 1	
	"Hard Permalloy" playback head x 1
	"Ferrite" erasing head x 1
Motor .....	DC servo motor x 2
Wow and Flutter .....	0.09% (WRMS)
	±0.19% (DIN)
Fast Winding Time .....	Approximately 100 seconds (C-60 tape)
Frequency Response	
-20 dB recording:	
TYPE IV (Metal) tape .....	20 to 16,500 Hz
TYPE II (High/CrO <sub>2</sub> ) tape .....	20 to 16,000 Hz
TYPE I (Normal) tape .....	20 to 16,000 Hz
Signal-to-Noise Ratio	
Dolby NR OFF .....	More than 57 dB
Noise Reduction Effect	
Dolby B-type NR ON .....	More than 10 dB (at 5 kHz)
Dolby C-type NR ON .....	More than 19 dB (at 5 kHz)
Harmonic Distortion .....	No more than 0.8%
	(at -4 dB: 160 nwb/m)
Input (Sensitivity)	
LINE (INPUT) .....	100 mV (Input impedance 68 kΩ)
Output (Reference level)	
LINE (OUTPUT) .....	0.5 V (Output impedance 1.9 kΩ)

### Subfunctions

- Automatic reverse
- DOLBY B/C type NR
- Music search over ±15 selections
- Synchronized copy start
- High-speed and normal-speed copy (DECK I → DECK II)
- Relay playback/blank skip
- Peak level meter with peak-hold function
- Automatic space recording mute
- Automatic tape selector
-  System remote control available
- Rewind -Auto play

### Miscellaneous

Power Requirements	
U.K. and Australian models .....	AC 220 ~ 230 volts, 50/60 Hz
U.S. and Canadian models .....	AC 120 volts, 60 Hz
Power Consumption .....	16W
Dimensions .....	420 (W) x 125 (H) x 250 (D) mm
	16 - 9/16 (W) x 4 - 7/8 (H) x 9 - 13/16 (D)
Weight (without package)	
U.K. and Australian models .....	3.9 kg
	(8 lb 10 oz)
U.S. and Canadian models .....	3.8 kg
	(8 lb 6 oz)

### Accessories

Operating instructions .....	1
Connection cord with pin plugs .....	2
 Remote control cord .....	1

### NOTE:

*Specifications and design subject to possible modifications without notice, due to improvements.*