

Service Manual

ORDER NO.
ARP2678

STEREO DOUBLE CASSETTE DECK

CT-W802R

CT-W820R

CT-W720R

- Refer to the service manual ARP2547 for CT-W801R AND CT-W701R.
- This manual is applicable to the following: CT-W802R/KU, KC and SD; CT-W820R/HB and HEM; CT-W720R/HEM.

CT-W802R, CT-W820R AND CT-W720R HAVE THE FOLLOWING:

Type	Model			Power Requirement	Remarks
	CT-W802R	CT-W820R	CT-W720R		
KU	○	-	-	AC120V only	
KC	○	-	-	AC120V only	
HEM	-	○	○	AC220 - 230V, 230 - 240V (switchable) *	
HB	-	○	-	AC220 - 230V, 230 - 240V (switchable) *	
SD	○	-	-	AC110V, 120 - 127V, 220V, 240V (switchable)	

* Change the connection of the power transformer's primary wiring.

3965

1. CONTRAST OF MISCELLANEOUS PARTS

NOTES:

- Parts marked by "NSP" are generally unavailable because they are not in our Master Spare Parts List.
- The Δ mark found on some component parts indicates the importance of the safety factor of the part. Therefore, when replacing, be sure to use parts of identical designation.
- Parts marked by "⊙" are not always kept in stock. Their delivery time may be longer than usual or they may be unavailable.

1.1 FOR CT-W802R/KU, KC, SD, CT-W820R/HEM AND HB

CT-W802R/KU, KC, SD, CT-W820R/HEM, HB and CT-W801R/KUC have the same construction except for the following :

Mark	Symbol & Description	Part No.						Remarks
		CT-W801R/ KUC	CT-W802R/ KU	CT-W802R/ KC	CT-W802R/ SD	CT-W820R/ HEM	CT-W820R/ HB	
NSP	MAIN unit	RWZ2486	
NSP	MAIN unit	RWZ2942	RWZ2942	RWZ3005	RWZ2944	RWZ2944	
NSP	DISPLAY unit	RWZ2490	
	DISPLAY unit	RWZ2946	RWZ2946	RWZ2946	RWZ2952	RWZ2952	
	HP. MIC unit	RWZ2487	RWZ2487	RWZ2487	RWZ2487	RWZ2506	RWZ2506	
NSP	OPERATE SW (1) unit	RWZ2488	RWZ2488	RWZ2488	RWZ2488	RWZ2507	RWZ2507	
NSP	OPERATE SW (2) unit	RWZ2489	RWZ2489	RWZ2489	RWZ2489	RWZ2508	RWZ2508	
NSP	TRANS 2 unit	RWZ2491	RWZ2491	RWZ2491	RWZ2491	RWZ2510	RWZ2510	
Δ	Strain relief	CM - 22C	CM - 22C	CM - 22C	CM - 22B	CM - 22B	CM - 22B	
Δ	AC power cord	PDG1015	PDG1015	PDG1015	PDG1013	PDG1003	VDG1051	
Δ	FU1, FU2 Fuse (1.5A)	REK1001	DEK1014	DEK1014	
Δ	FU1, FU2 Fuse (1.6A)	REK - 102	REK - 102	REK - 102	
Δ	T1 Power transformer (AC120V)	RTT1165	RTT1165	RTT1165	
Δ	T1 Power transformer (AC110/120 - 127/220/240V)	RTT1167	
Δ	T1 Power transformer (AC220 - 230/230 - 240V)	RTT1166	RTT1166	
Δ	Voltage selector (AC110/120 - 127/220/240V)	PSB1002	
⊙	Mechanism unit (DECK I)	RYM1169	RYM1207	RYM1207	RYM1207	RYM1209	RYM1209	
⊙	Mechanism unit (DECK II)	RYM1170	RYM1208	RYM1208	RYM1208	RYM1210	RYM1210	
	Function knob A	RAC1714	RAC1807	RAC1807	RAC1807	RAC1807	RAC1807	
	Door pocket R	RAH2073	RAH2257	RAH2257	RAH2257	RAH2257	RAH2257	
NSP	Door pocket L	RAH2076	RAH2258	RAH2258	RAH2258	RAH2258	RAH2258	
	Rear panel	RNA1599	RNA1695	RNA1694	RNA1698	RNA1696	RNA1697	
	Cord clamper	RNH - 184	RNH - 184	RNH - 184	RNH - 184	RNH - 184	*1
	Front panel assembly	RXX1518	
NSP	Name plate	PAM1407	
NSP	Name plate	RAM1007	RAM1007	RAM1007	RAM1007	RAM1007	
	Front panel	RAH2065	
	Front panel	RAH2254	RAH2254	RAH2254	RAH2255	RAH2255	
	FL lens	RAH2079	RAH2079	RAH2079	RAH2079	RAH2080	RAH2080	
	Packing case	RHG1368	RHG1469	RHG1469	RHG1472	RHG1470	RHG1471	
	Remote control unit	RPX1057	RPX1057	
	Battery cover	PZN1010	PZN1010	
NSP	Battery (R03, AAA)	VEM - 022	VEM - 022	

Mark	Symbol & Description	Part No.						Remarks
		CT-W801R/ KUC	CT-W802R/ KU	CT-W802R/ KC	CT-W802R/ SD	CT-W820R/ HEM	CT-W820R/ HB	
	Spacer A	RHC1037	*2
	Spacer B	RHC1038	*3
	Connection cord (with mini plug)	PDE - 319	PDE - 319	PDE - 319	PDE - 319	
	Operating instructions (English)	RRB1120	RRB1124	RRB1124	RRB1124	
	Operating instructions (English/French)	RRE1068	
	Operating instructions (Spanish)	RRD1134	
	Operating instructions (English/French/German/Italian/Dutch/ Swedish/Spanish/Portugese)	RRE1069	

Note) *1 - *3 : See "1.3 EXPLODED VIEW AND PACKING".

MAIN UNIT

RWZ2942, RWZ3005, RWZ2944 and RWZ2486 have the same construction except for the following:

Mark	Symbol & Description	Part No.				Remarks
		RWZ2486	RWZ2942	RWZ3005	RWZ2944	
	Q743, Q744	2SC3311A	2SC3311A	2SC3311A	
	D743	1SS254	1SS254	1SS254	
	D910 - D912	1SS254	1SS254	1SS254	
	C741	CEAS331M16	CEAS331M16	CEAS331M16	
	C910	CKCYF103Z50	CKCYF103Z50	CKCYF103Z50	
	R743, R744	RD1/6PM222J	RD1/6PM102J	RD1/6PM102J	RD1/6PM102J	
	R745	RD1/6PM222J	RD1/6PM222J	RD1/6PM222J	
	R746	RD1/6PM223J	RD1/6PM223J	RD1/6PM223J	
	R747	RD1/6PM912J	RD1/6PM912J	RD1/6PM912J	
	R748, R749	RD1/6PM103J	RD1/6PM103J	RD1/6PM103J	
	R804, R854	RCN1053	RD1/6PM822J	RD1/6PM822J	RD1/6PM822J	
	R719, R720	RD1/6PM332J	RD1/6PM332J	RD1/6PM222J	RD1/6PM222J	
	JA902, JA903 Jack	RKN1004	RKN1004	RKN1004	

DISPLAY UNIT

RWZ2946, RWZ2952 and RWZ2490 have the same construction except for the following:

Mark	Symbol & Description	Part No.			Remarks
		RWZ2490	RWZ2946	RWZ2952	
	IC1501	HC - 177	
	S1509 (FADE OUT)	RSG1034	RSG1034	
	V1501	RAW1105	RAW1105	RAW1107	

HP. MIC UNIT

Although RWZ2506 and RWZ2487 are different in part number, they consist of the same components.

OPERATE SW (1) UNIT

Although RWZ2507 and RWZ2488 are different in part number, they consist of the same components.

OPERATE SW (2) UNIT

Although RWZ2508 and RWZ2489 are different in part number, they consist of the same components.

TRANS 2 UNIT

Although RWZ2510 and RWZ2491 are different in part number, they consist of the same components.

MECHANISM UNIT (DECK I)

RYM1207, RYM1209 and RYM1169 have the same construction except for the following:

Mark	Symbol & Description	Part No.			Remarks
		RYM1169	RYM1207	RYM1209	
	Washer	RBF1044	
	Gear play	RNK1720	RNK1867	RNK1867	
	Arm play L assembly	RXA1405	
	Arm play R assembly	RXA1406	
	Arm play L	RNK1866	RNK1866	
	Arm play R	RNK1868	RNK1868	
	Switch mode	RSN1020	RSN1022	RSN1022	
	Solenoid	RXP1017	RXP1020	RXP1020	
	Motor assembly	RXM1052	RXM1060	RXM1061	
	Belt main	REB1159	REB1159	REB1162	
	Gear FW R	RNK1733	
	Flywheel assembly L	RXA1423	RXA1423	RXA1476	
	Flywheel assembly R	RXA1424	RXA1424	
	Flywheel R	RXA1415	

MECHANISM UNIT (DECK II)

RYM1208, RYM1210 and RYM1170 have the same construction except for the following:

Mark	Symbol & Description	Part No.			Remarks
		RYM1170	RYM1208	RYM1210	
	Washer	RBF1044	
	Gear play	RNK1720	RNK1867	RNK1867	
	Arm play L assembly	RXA1405	
	Arm play R assembly	RXA1406	
	Arm play L	RNK1866	RNK1866	
	Arm play R	RNK1868	RNK1868	
	Switch mode	RSN1020	RSN1022	RSN1022	
	Motor assembly	RXM1052	RXM1060	RXM1061	
	Solenoid	RXP1017	RXP1020	RXP1020	
	Belt main	REB1159	REB1159	REB1162	
	Gear FW R	RNK1733	
	Flywheel assembly L	RXA1423	RXA1423	RXA1476	
	Flywheel assembly R	RXA1424	RXA1424	
	Flywheel R	RXA1415	

1.2 FOR CT-W720R/HEM

CT-W720R/HEM and CT-W701R/HEM have the same construction except for the following:

Mark	Symbol & Description	Part No.		Remarks
		CT-W701R/HEM	CT-W720R/HEM	
NSP	MAIN unit	RWZ2517	*1
	MAIN unit	RWZ2945	
NSP	DISPLAY unit	RWZ2521	
	DISPLAY unit	RWZ2953	
	Function knob A	RAC1824	RAC1806	
	Door pocket R	RAH2074	RAH2219	
	Door pocket L	RAH2077	RAH2259	
NSP	Front panel	RAH2067	
	Front panel	RAH2256	
NSP	Rear panel	RNA1574	RNA1699	
NSP	Name plate	PAM1407	
	Name plate	RAM1007	
	Cord clamper	RNH - 184	
⊙	Mechanism unit (DECK I)	RYM1172	RYM1209	
⊙	Mechanism unit (DECK II)	RYM1173	RYM1210	
	Front panel assembly	RXX1519	
	Packing case	RHG1372	RHG1473	
	Operating instructions (English/French/German/Italian/Dutch/Swedish/ Spanish/Portuguese)	RRE1063	RRE1069	

Note) *1 : See " 1.3 EXPLODED VIEW AND PACKING ".

MAIN UNIT

RWZ2945 and RWZ2517 have the same construction except for the following:

Mark	Symbol & Description	Part No.		Remarks
		RWZ2517	RWZ2945	
	Q743, Q744	2SC3311A	
	D743	1SS254	
	C741	CEAS331M16	
	R743, R744	RD1/6PM222J	RD1/6PM102J	
	R745	RD1/6PM222J	
	R746	RD1/6PM223J	
	R747	RD1/6PM912J	
	R748, R749	RD1/6PM103J	
	R804, R854	RCN1053	RD1/6PM822J	

DISPLAY UNIT

RWZ2953 and RWZ2521 have the same construction except for the following:

Mark	Symbol & Description	Part No.		Remarks
		RWZ2521	RWZ2953	
	S1509 (FADE OUT)	RSG1034	

MECHANISM UNIT (DECK I)

RYM1209 and RYM1172 have the same construction except for the following:

Mark	Symbol & Description	Part No.		Remarks
		RYM1172	RYM1209	
	Washer	RBF1044	
	Gear play	RNK1720	RNK1867	
	Arm play L assembly	RXA1405	
	Arm play R assembly	RXA1406	
	Arm play L	RNK1866	
	Arm play R	RNK1868	
	Switch mode	RSN1020	RSN1022	
	Motor assembly	RXM1051	RXM1061	
	Solenoid	RXP1017	RXP1020	

MECHANISM UNIT (DECK II)

RYM1210 and RYM1173 have the same construction except for the following:

Mark	Symbol & Description	Part No.		Remarks
		RYM1173	RYM1210	
	Washer	RBF1044	
	Gear play	RNK1720	RNK1867	
	Arm play L assembly	RXA1405	
	Arm play R assembly	RXA1406	
	Arm play L	RNK1866	
	Arm play R	RNK1868	
	Switch mode	RSN1020	RSN1022	
	Motor assembly	RXM1051	RXM1061	
	Solenoid	RXP1017	RXP1020	

1.3 EXPLODED VIEW AND PACKING

● EXPLODED VIEW

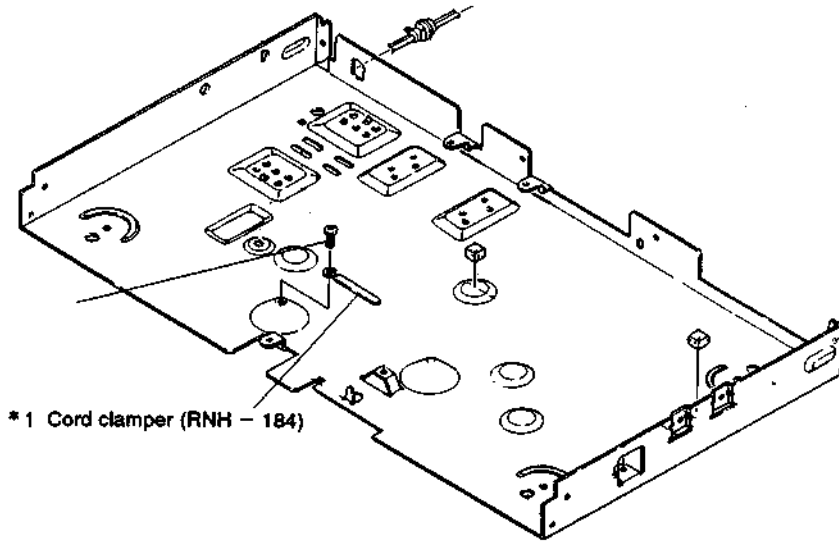

● PACKING AND PARTS LIST

Parts List (CT-W820R/HB type only)

Mark	No.	Description	Part No.
	1	
	2	Connection cord assembly	RDE1002
	3	
	4	Operating instructions	RRB1124
	5	Pad (R)	RHA1045
	6	Pad (F)	RHA1088
	7	Packing case	RHG1471
	8	Sheet	RHX - 034
	9	Control cord	RDE1030
* 2	10	Spacer A	RHC1037
* 3	11	Spacer B	RHC1038
	12	Remote control (includes No.13)	RPX1057
	13	Battery cover	PZN1010
NSP	14	Battery (R03, AAA)	VEM - 022
NSP	15	Warranty card	ARW - 088

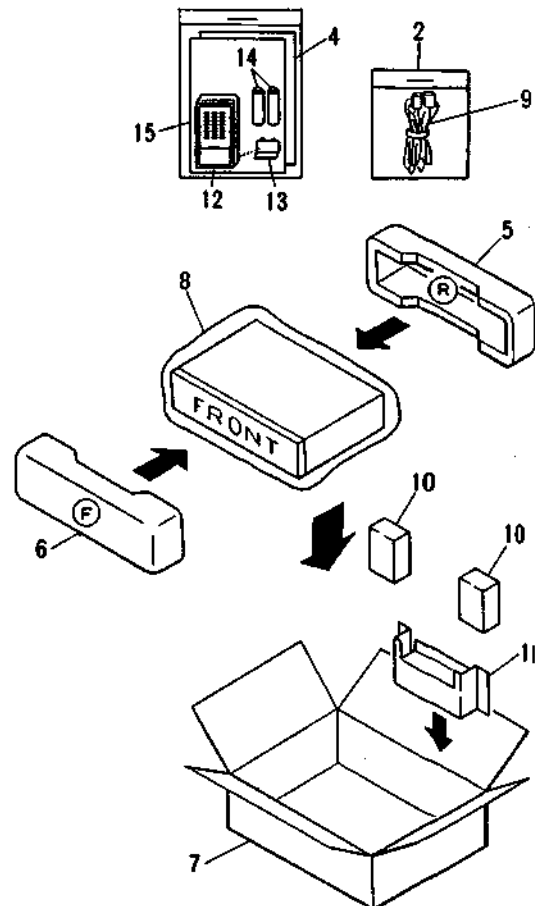

1.4 SCHEMATIC AND PCB DIAGRAM

- CT-W802R/KU, KC, SD, CT-W820R/HEM, HB and CT-W801R/KUC are the same as except for the circuit indicated with [].
- CT-W720R/HEM and CT-W701R/HEM are the same as except for the circuit indicated with [].

● SCHEMATIC DIAGRAM

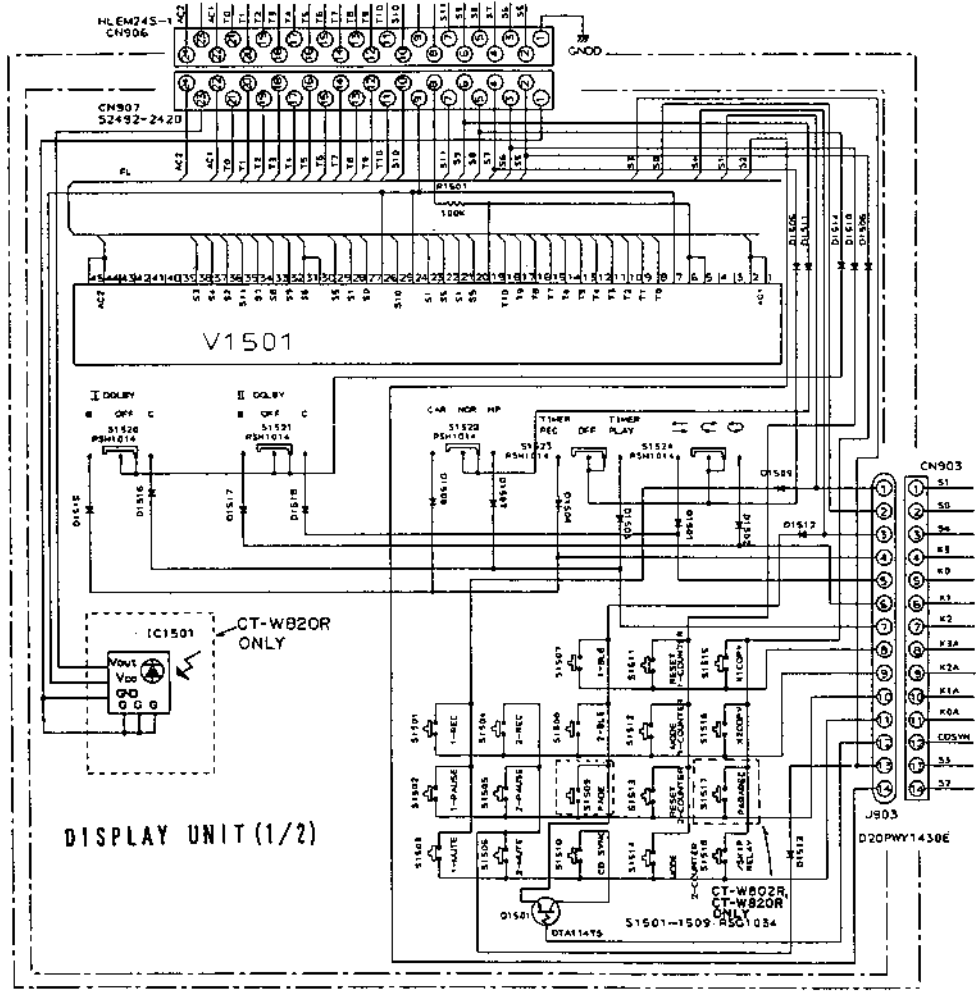
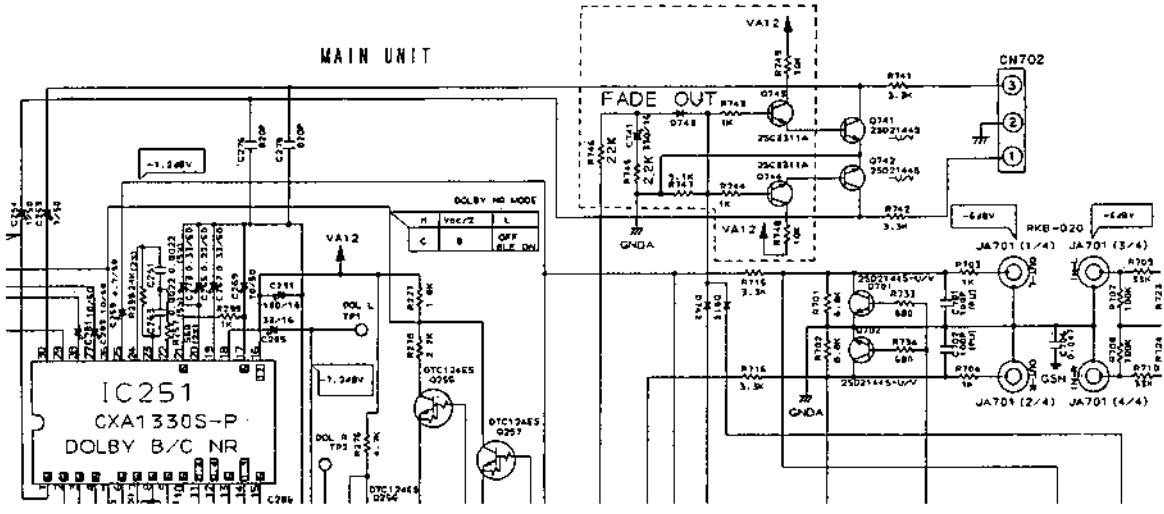

A

B

C

D

● PCB DIAGRAM

DISPLAY UNIT

A

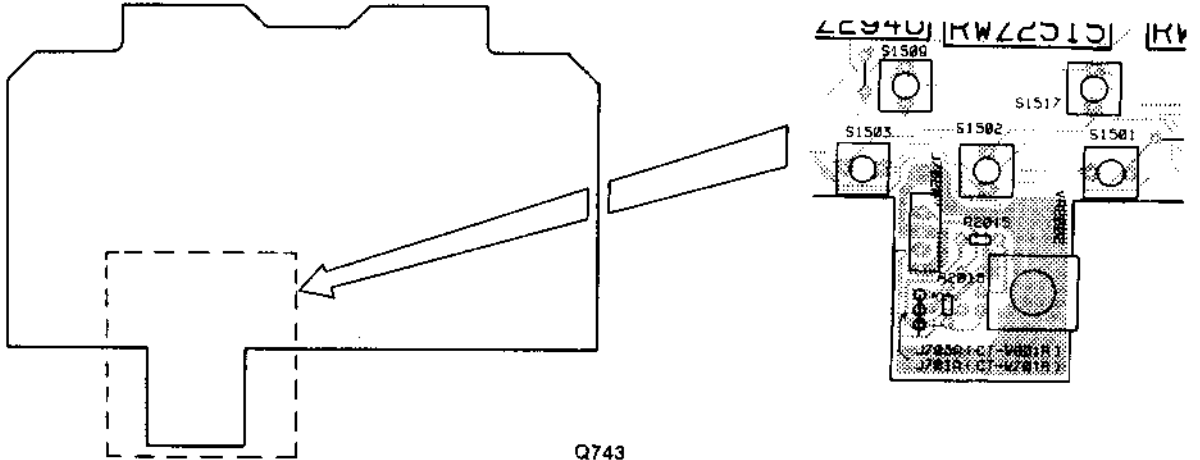

Q743
Q744

B

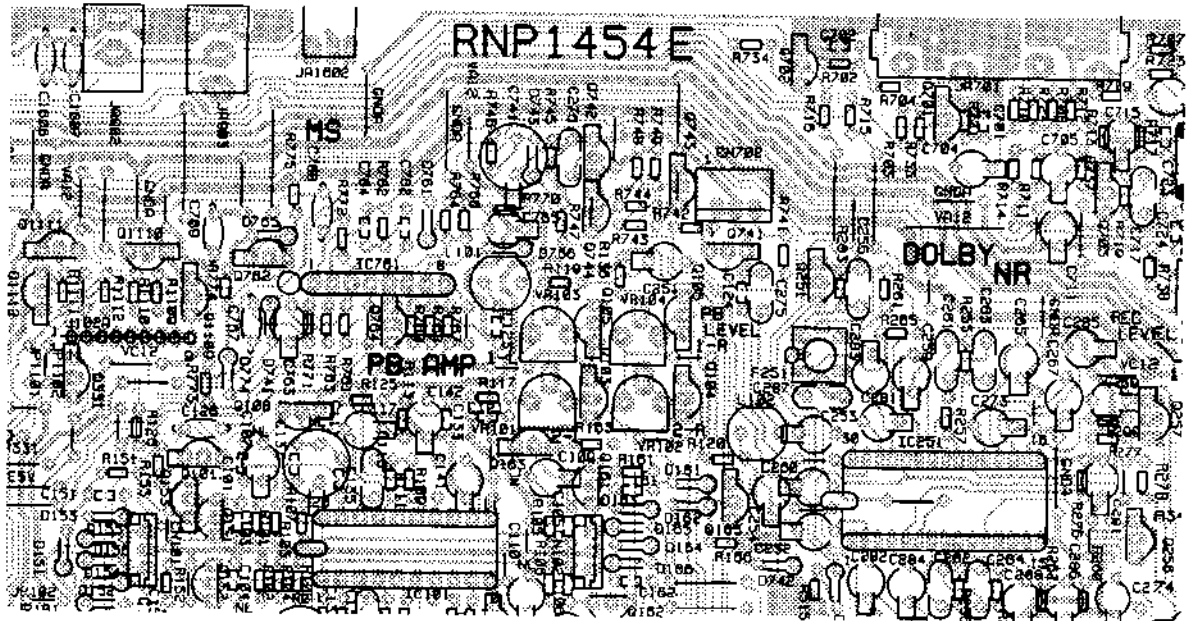

C

MAIN UNIT

D

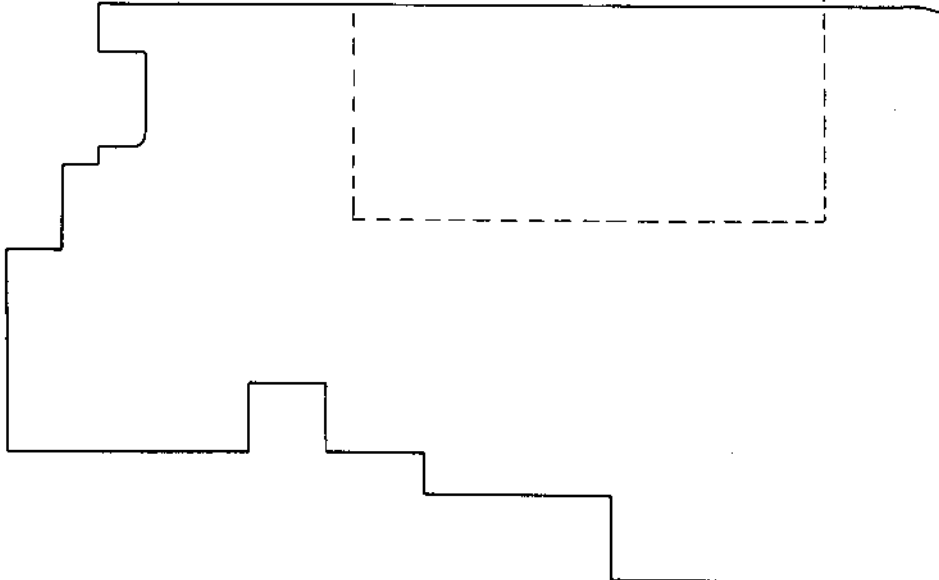

3805

PIONEER
The Art of Entertainment

Service Manual

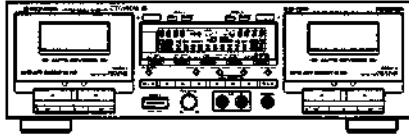

ORDER NO.
ARP2547

STEREO DOUBLE CASSETTE DECK

CT-W801R

CT-W851R

CT-W701R

CT-W801R, CT-W851R AND CT-W701R HAVE THE FOLLOWING:

Type	Model			Power Requirement	Remarks
	CT-W801R	CT-W851R	CT-W701R		
KUC	○	-	○	AC120V only	
KUC/CA	○	-	○	AC120V only	
HEM	-	○	○	AC220 - 230V, 230 - 240V (Switchable) *	
HB	-	○	○	AC220 - 230V, 230 - 240V (Switchable) *	
SD	○	-	-	AC110V, 120 - 127V, 220V, 240V (Switchable)	

* Change the connection of the power transformer's primary wiring.

- This manual is applicable to the following: CT-W801R/KUC, KUC/CA, and SD; CT-W851R/HEM and HB; CT-W701R/KUC, KUC/CA, HEM and HB.
- For the following: CT-W801R/SD; CT-W851R/HEM and HB, refer to page 63.
For the following: CT-W701R/HEM and HB, refer to page 65.
- Ce manuel pour le service comprend les explications de réglage en français.
- Este manual de servicio trata del método ajuste escrito en español.
- KUC/CA type is identical to KUC type with French instruction manual.
For all information except for the instruction, refer to KUC type.

3805

CONTENTS

1. SAFETY INFORMATION	2	9. IC DESCRIPTIONS	43
2. EXPLODED VIEWS AND PARTS LIST	3	10. CIRCUIT DESCRIPTIONS	61
3. PACKING AND PARTS LIST	9	11. FOR CT-W801R/SD, CT-W851R/HEM AND HB TYPES	63
4. SCHEMATIC DIAGRAMS	10	12. FOR CT-W701R/HEM AND HB TYPES	65
5. PCB CONNECTIONS DIAGRAM	17	13. PANEL FACILITIES	67
6. BLOCK DIAGRAM	25	14. SPECIFICATIONS	68
7. PCB PARTS LIST	26		
8. ADJUSTMENTS	31		
8. REGLAGES	35		
8. AJUSTES	39		

This service manual is intended for qualified service technicians; it is not meant for the casual do-it-yourselfer. Qualified technicians have the necessary test equipment and tools, and have been trained to properly and safely repair complex products such as those covered by this manual.

Improperly performed repairs can adversely affect the safety and reliability of the product and may void the warranty. If you are not qualified to perform the repair of this product properly and safely, you should not risk trying to do so and refer the repair to a qualified service technician.

WARNING

Lead in solder used in this product is listed by the California Health and Welfare agency as a known reproductive toxicant which may cause birth defects or other reproductive harm (California Health & Safety Code, Section 25249.5).

When servicing or handling circuit boards and other components which contain lead in solder, avoid unprotected skin contact with the solder. Also, when soldering do not inhale any smoke or fumes produced.

1. SAFETY INFORMATION

(FOR USA MODEL ONLY)

1. SAFETY PRECAUTIONS

The following check should be performed for the continued protection of the customer and service technician.

LEAKAGE CURRENT CHECK

Measure leakage current to a known earth ground (water pipe, conduit, etc.) by connecting a leakage current tester such as Simpson Model 229-2 or equivalent between the earth ground and all exposed metal parts of the appliance (input/output terminals, screwheads, metal overlays, control shaft, etc.). Plug the AC line cord of the appliance directly into a 120V AC 60Hz outlet and turn the AC power switch on. Any current measured must not exceed 0.5mA.

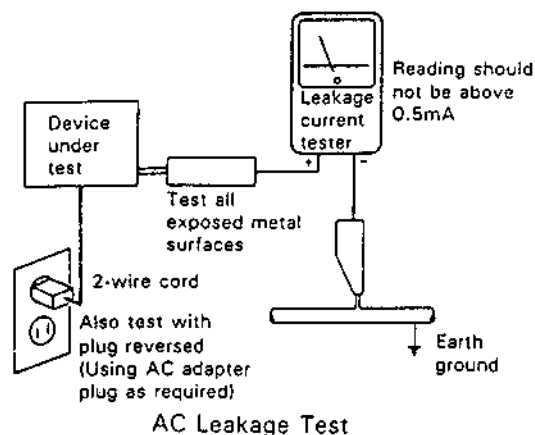

AC Leakage Test

ANY MEASUREMENTS NOT WITHIN THE LIMITS OUTLINED ABOVE ARE INDICATIVE OF A POTENTIAL SHOCK HAZARD AND MUST BE CORRECTED BEFORE RETURNING THE APPLIANCE TO THE CUSTOMER.

2. PRODUCT SAFETY NOTICE

Many electrical and mechanical parts in the appliance have special safety related characteristics. These are often not evident from visual inspection nor the protection afforded by them necessarily can be obtained by using replacement components rated for voltage, wattage, etc. Replacement parts which have these special safety characteristics are identified in this Service Manual.

Electrical components having such features are identified by marking with a Δ on the schematics and on the parts list in this Service Manual.

The use of a substitute replacement component which does not have the same safety characteristics as the PIONEER recommended replacement one, shown in the parts list in this Service Manual, may create shock, fire, or other hazards.

Product Safety is continuously under review and new instructions are issued from time to time. For the latest information, always consult the current PIONEER Service Manual. A subscription to, or additional copies of, PIONEER Service Manual may be obtained at a nominal charge from PIONEER.

2. EXPLODED VIEWS AND PARTS LIST

2.1 EXTERIOR (CT-W801R/KUC, KUC/CA AND CT-W701R/KUC, KUC/CA TYPES)

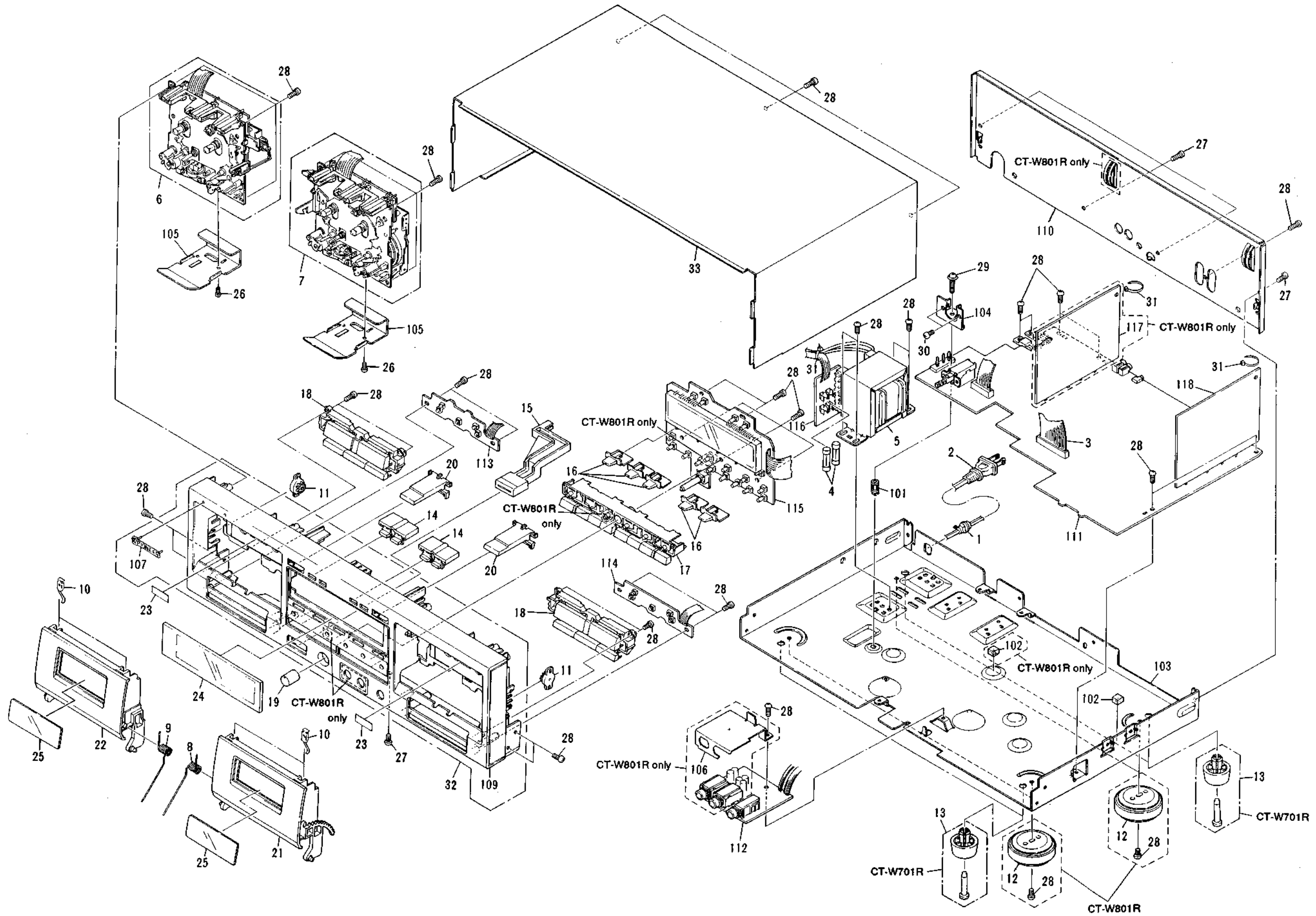

NOTES:
 • Parts marked with a triangle (▲) to use per the instructions.
 • Parts marked with a circle (○) to use per the instructions.

Parts List
 Marked with a triangle (▲) to use per the instructions.

▲
 ▲
 ▲
 ▲
 ○
 ○

A
B
C
D

1 2 3 4 5 6 4

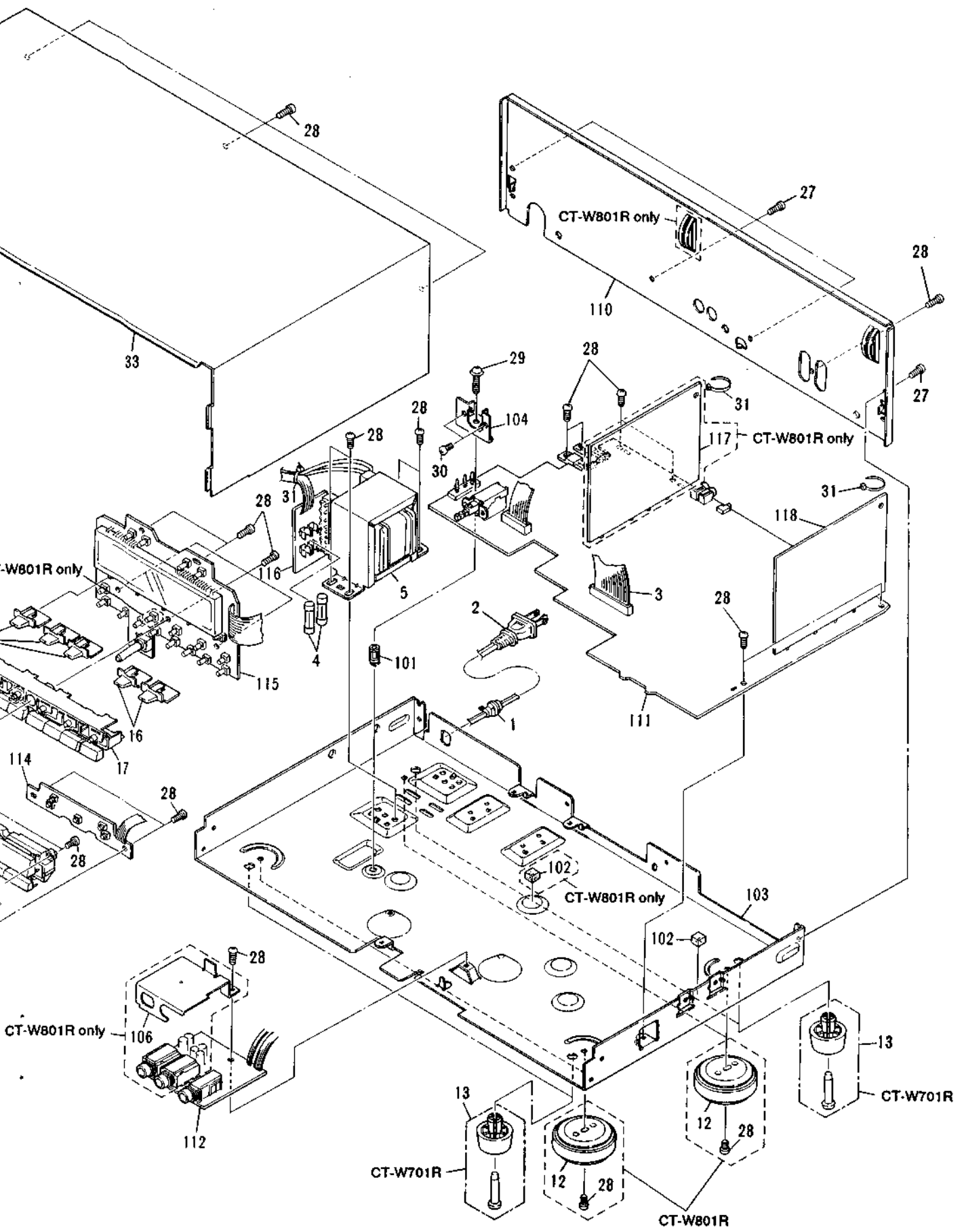

NOTES:

- Parts marked by "NSP" are generally unavailable because they are not in our Master Spare Parts List.
- The Δ mark found on some component parts indicates the importance of the safety factor of the part. Therefore, when replacing, be sure to use parts of identical designation.
- Parts marked by "⊙" are not always kept in stock. Their delivery time may be longer than usual or they may be unavailable.

Parts List

Mark	No.	Description	Part No.	Mark	No.	Description	Part No.
Δ	1	Strain relief	CM - 22C	NSP	101	PCB spacer	PNY - 404
Δ	2	AC power cord	PDG1015	NSP	102	PCB spacer (rubber)	REB1201
	3	Lead card 24P	RDD1265	NSP	103	Main chassis	RNB1070
Δ	4	FU1, FU2 Fuse (1.5A)	REK1001	NSP	104	SW bracket	RNE1441
Δ	5	Power transformer	RTT1165	NSP	105	Mechanism shield plate	RNE1519
\odot	6	Mechanism unit (Deck I)	RYM1169	NSP	106	Shield case (CT-W801R only)	RNE1520
\odot	7	Mechanism unit (Deck II)	RYM1170	NSP	107	Name plate	PAM1407
	8	Door spring L	RBH1304	NSP	108	
	9	Door spring R	RBH1305	NSP	109	Front panel (CT-W801R)	RAH2065
	10	Half pressure spring	RBK1004	NSP	110	Front panel (CT-W701R)	RAH2067
	11	Damper assembly	REC1005	NSP	110	Rear panel (CT-W801R)	RNA1569
	12	Insulator (CT-W801R)	PNW1912	NSP		Rear panel (CT-W701R)	RNA1573
	13	Foot assembly (CT-W701R)	PXA1201				
	14	Counter knob	RAC1426				
	15	Power knob	RAC1712				
	16	Slide knob	RAC1713				
	17	Function knob A (CT-W801R)	RAC1714				
		Function knob A (CT-W701R)	RAC1716				
	18	Function knob B	RAC1717				
	19	VR knob	RAC1719				
	20	Eject knob	RAC1722				
	21	Door pocket R (CT-W801R)	RAH2073				
		Door pocket R (CT-W701R)	RAH2074				
	22	Door pocket L (CT-W801R)	RAH2076				
		Door pocket L (CT-W701R)	RAH2077				
	23	Remain display paper	REE - 113				
	24	FL lens	RAH2079				
	25	Door lens	RAH2086				
	26	Screw	BBZ20P040FMC				
	27	Screw	BBZ30P060FZK				
	28	Screw	BBZ30P080FMC				
	29	Screw	IBZ30P150FCU				
	30	Screw	PMA30P060FMC				
	31	Cord clamber	REC - 371				
	32	Front panel assembly (CT-W801R)	RXX1518				
		Front panel assembly (CT-W701R)	RXX1519				
	33	Bonnet assembly	RXX1521				

2.2 MECHANISM UNIT
(CT-W801R/KUC, KUC/CA, SD, CT-W701R/KUC AND KUC/CA TYPES)

Parts List

Mark	No.	Description	Part No.	Mark	No.	Description	Part No.
	1	ASS'Y HOLDER HEAD	RXA1477		46	P.C. BOARD	RNP1348
	2	FLAME HEAD	RNK1715		47	HOUSING	RKP1397
	3	LEVER HEAD	RNK1716		48	EJECT LEVER R (DECK I)	RNK1703
	4	SPRING AZIMUTH	RBK1006			EJECT LEVER L (DECK II)	RNK1702
	5	ASS'Y ARM ASSIST	RXA1401		49	COLLAR	RNK1704
	6	GEAR ARM HEAD	RNK1717		50	WIRE HEAD (DECK I)	RKP1505
	7	SPRING CASSETTE	RBK1039			WIRE HEAD (DECK II)	RKP1399
	8	EJECT LOCK	RNK1718		61	SPRING	RBH1282
	9	CAP REEL	RNK1719		62	SPRING	RBH1283
	10	ASS'Y PINCH ARM L	RXA1403		63	SPRING	RBH1284
	11	CHASSIS HEAD	RNE1437		64	SPRING	RBH1286
	12	ASS'Y PINCH ARM R	RXA1404		65	SPRING	RBH1288
	13	ASS'Y ARM PLAY L	RXA1405		66	SPRING	RBH1290
	14	GEAR PLAY	RNK1720		67	SPRING	RBH1285
	15	ASS'Y ARM PLAY R	RXA1406		68	SPRING	RBH1287
	16	CHASSIS OS	RXA1411		69	SPRING	RBH1289
	17	ASS'Y SUB REEL L	RXA1407		70	SPRING	RBH1291
	18	SOLENOID	RXP1017		71	SPRING	RBH1292
	19	WIRE	RDC1006		72	FWR SPRING	RBH1061
	20	ARM RVS	RNK1721		73	FWF SPRING	RBH1325
	21	GEAR FF	RNK1723		74	SPRING (DECK I)	RBH1293
	22	ASS'Y ARM FR	RXA1412			SPRING (DECK II)	RBH1294
	23	ASS'Y PULLEY FR	RXA1413		81	SCREW (AZIMUTH)	RBA1023
	24	BELT FR	REB1158		82	SCREW	RBA1027
	25	METAL	RNG1048		83	SCREW	RBA1030
	26	ASS'Y FLYWHEEL L	RXA1423		84	SCREW	PCZ20P040FMC
	27	METAL	RNG1005		85	SCREW	RBA1093
	28	ARM BRAKE	RNK1724		86	SCREW	RBA1094
	29	ASS'Y SUB REEL R	RXA1408		87	SCREW	RBA1086
	30	ARM TRIGGER	RNK1722		88	SCREW	RBA1095
	31	GEAR CAM	RNK1725		101	WASHER	RBF1044
	32	METAL	RNG1049		102	WASHER	RBF1046
	33	ASS'Y FLYWHEEL R	RXA1424		103	WASHER	WA26D047D013
	34	METAL	RNG1004				
	35	WIRE	RDD1257				
NSP	36	HOLDER WIRE	RNK1683				
	37	P.C. BOARD	RNP1347				
	38	SWITCH MODE	RSN1020				
	39	SWITCH (LEAF)	RSN1019				
	40	HALL IC.	DN6851A				
	41	BRACKET FW	RNE1438				
	42					
	43	ASS'Y MOTOR	RXM1052				
NSP	44	WIRE	RDD1012				
	45	BELT MAIN	REB1159				

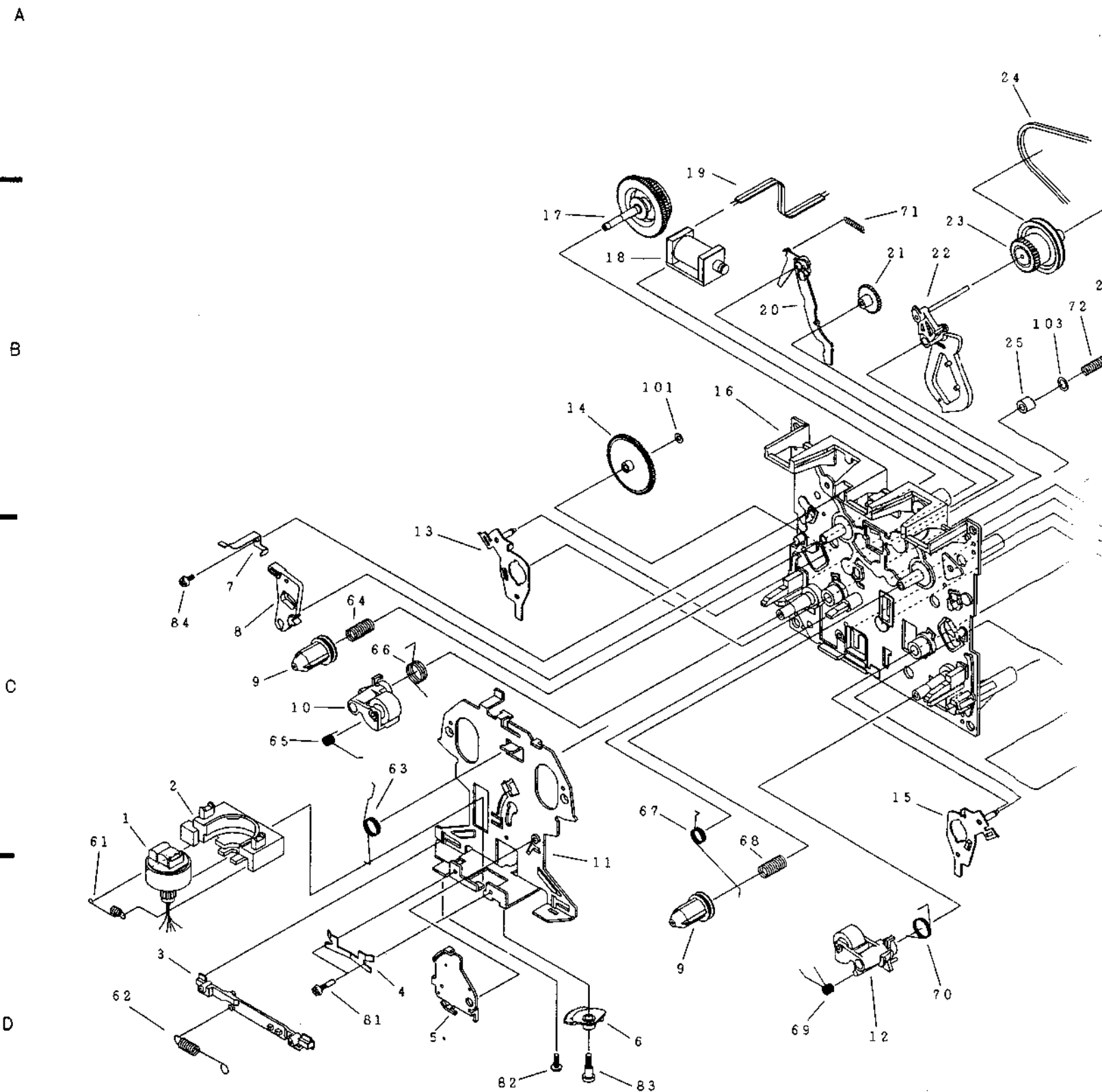

Mechanism Unit

A

B

C

D

A

B

C

D

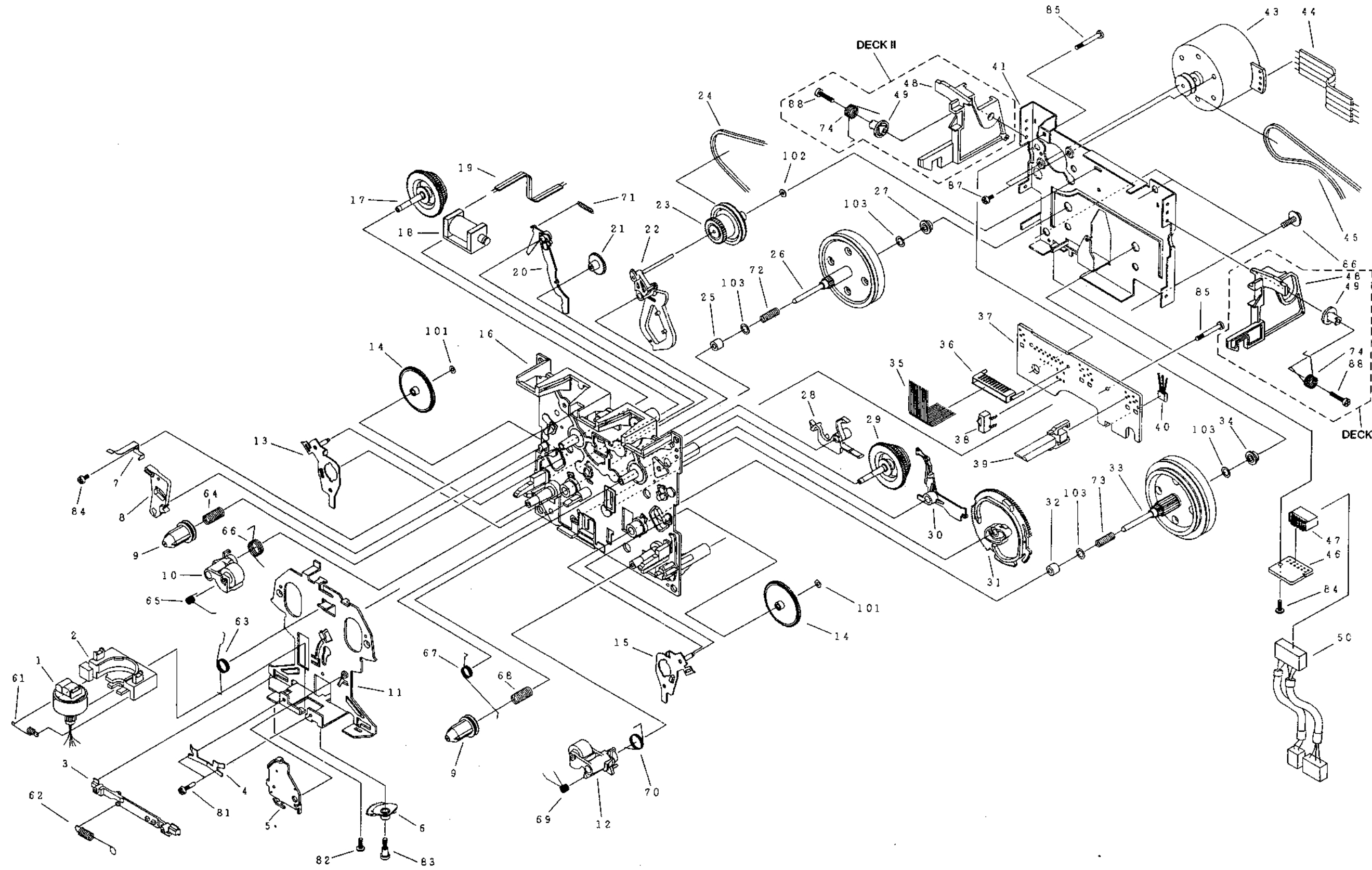

1

2

3

4

5

6

3. PACKING AND PARTS LIST

NOTES:

- Parts marked by "NSP" are generally unavailable because they are not in our Master Spare Parts List.
- The Δ mark found on some component parts indicates the importance of the safety factor of the part. Therefore, when replacing, be sure to use parts of identical designation.
- Parts marked by "⊙" are not always kept in stock. Their delivery time may be longer than usual or they may be unavailable.

Parts List (CT-W801R/KUC, KUC/CA and CT-W701R/KUC, KUC/CA types)

Mark	No.	Description	Part No.
	1	Connection cord (with mini plug)	PDE - 319
	2	Connection cord assembly	RDE1002
	3	Control cord	RDE1030
	4	Operating instructions (English : KUC)	RRE1120
		Operating instructions (English/French : KUC/CA)	RRE1064
	5	Pad (R)	RHA1045
	6	Pad (F)	RHA1088
	7	Packing case (CT-W801R)	RHG1368
		Packing case (CT-W701R)	RHG1371
	8	Sheet	RHX - 034
	9	Connection cord	RDE - 010
NSP	101	Warranty card	ARY1044

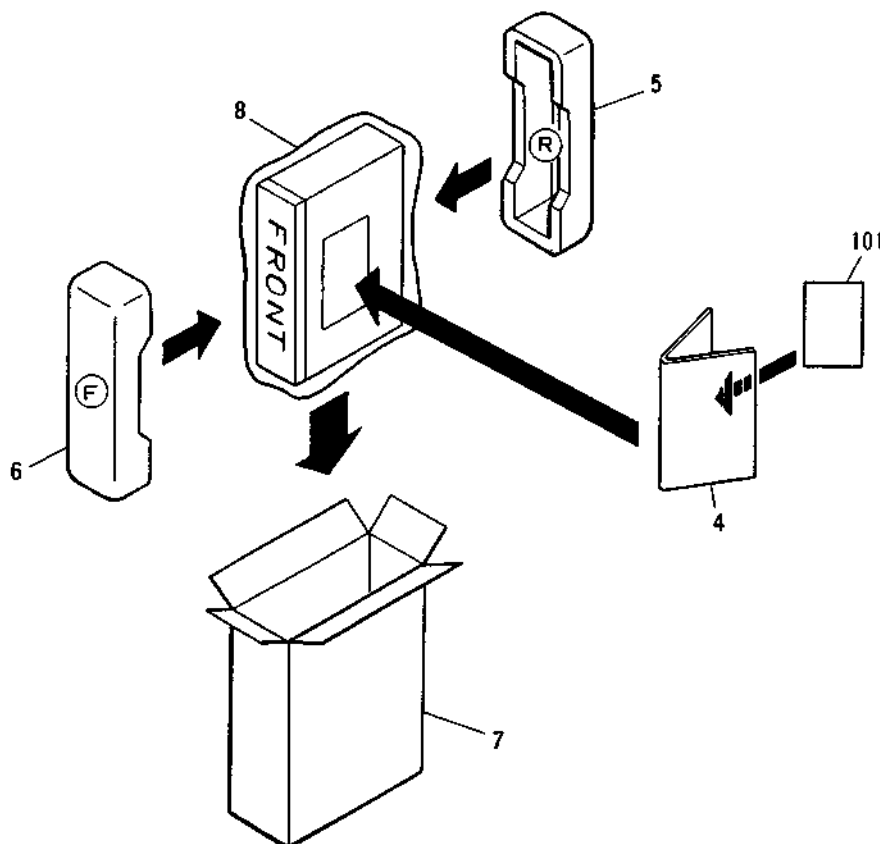
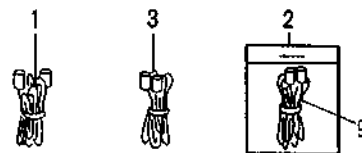

4. SCHEMATIC DIAGRAMS

1. RESISTORS :

Indicated in Ω , 1/4W, 1/6W, 1/8W, $\pm 5\%$ tolerance unless otherwise noted k ; k Ω , M ; M Ω , (F) ; $\pm 1\%$, (G) ; $\pm 2\%$, (K) ; $\pm 10\%$, (M) ; $\pm 20\%$ tolerance.

2. CAPACITORS :

Indicated in capacity (μ F) /voltage (V) unless otherwise noted p ; pF.
Indication without voltage is 50V except electrolytic capacitor.

3. VOLTAGE CURRENT :

; DC voltage (V) in stop mode.
 mA ; DC current in stop mode.

4. OTHERS :

; Signal route.
 ; Adjusting point

The Δ mark found on some component parts indicates the importance of the safety factor of the part. Therefore, when replacing, be sure to use parts of identical designation.
* marked capacitors and resistors have parts numbers.

This is the basic schematic diagram, but the actual circuit may vary due to improvements in design.

CT-W801R and CT-W851R

CT-W701R

5. SWITCHES (The underlined indicates the switch position)

MAIN UNIT

S1201 : POWER SW ON - OFF

OPERATE 1 UNIT

S1301 : FWD
S1302 : REV
S1303 : STOP
S1305 : FF
S1306 : REW

OPERATE 2 UNIT

S1401 : FWD
S1402 : REV
S1403 : STOP
S1406 : REV

DISPLAY UNIT

S1501 : 1 - REC
S1502 : 1 - PAUSE
S1503 : 1 - MUTE
S1504 : 2 - REC
S1505 : 2 - PAUSE
S1506 : 2 - MUTE
S1507 : 1 - BLE
S1508 : 2 - BLE
S1510 : CD SYNC
S1511 : RESET 1 - COUNTER
S1512 : MODE 1 - COUNTER
S1513 : RESET 2 - COUNTER
S1514 : MODE 2 - COUNTER
S1515 : X1 COPY
S1516 : X2 COPY
S1517 : PARAREC
S1518 : RELAY/SKIP
S1520 : I DOLBY B - OFF - C
S1521 : II DOLBY B - OFF - C
S1522 : CAR - NOR - HP
S1523 : TIMER REC - OFF - PLAY
S1524 : \neq - C - ϕ

MAIN UNIT

S1201 : POWER SW ON - OFF

OPERATE 1 UNIT

S1301 : FWD
S1302 : REV
S1303 : STOP
S1305 : FF
S1306 : REW

OPERATE 2 UNIT

S1401 : FWD
S1402 : REV
S1403 : STOP
S1406 : REV

DISPLAY UNIT

S1501 : 1 - REC
S1502 : 1 - PAUSE
S1503 : 1 - MUTE
S1504 : 2 - REC
S1505 : 2 - PAUSE
S1506 : 2 - MUTE
S1507 : 1 - BLE
S1508 : 2 - BLE
S1510 : CD SYNC
S1511 : RESET 1 - COUNTER
S1512 : MODE 1 - COUNTER
S1513 : RESET 2 - COUNTER
S1514 : MODE 2 - COUNTER
S1515 : X1 COPY
S1516 : X2 COPY
S1518 : RELAY/SKIP
S1520 : I DOLBY B - OFF - C
S1521 : II DOLBY B - OFF - C
S1522 : CAR - NOR - HP
S1523 : TIMER REC - OFF - PLAY
S1524 : \neq - C - ϕ

5. PCB CONNECTIONS DIAGRAM

• View from component side

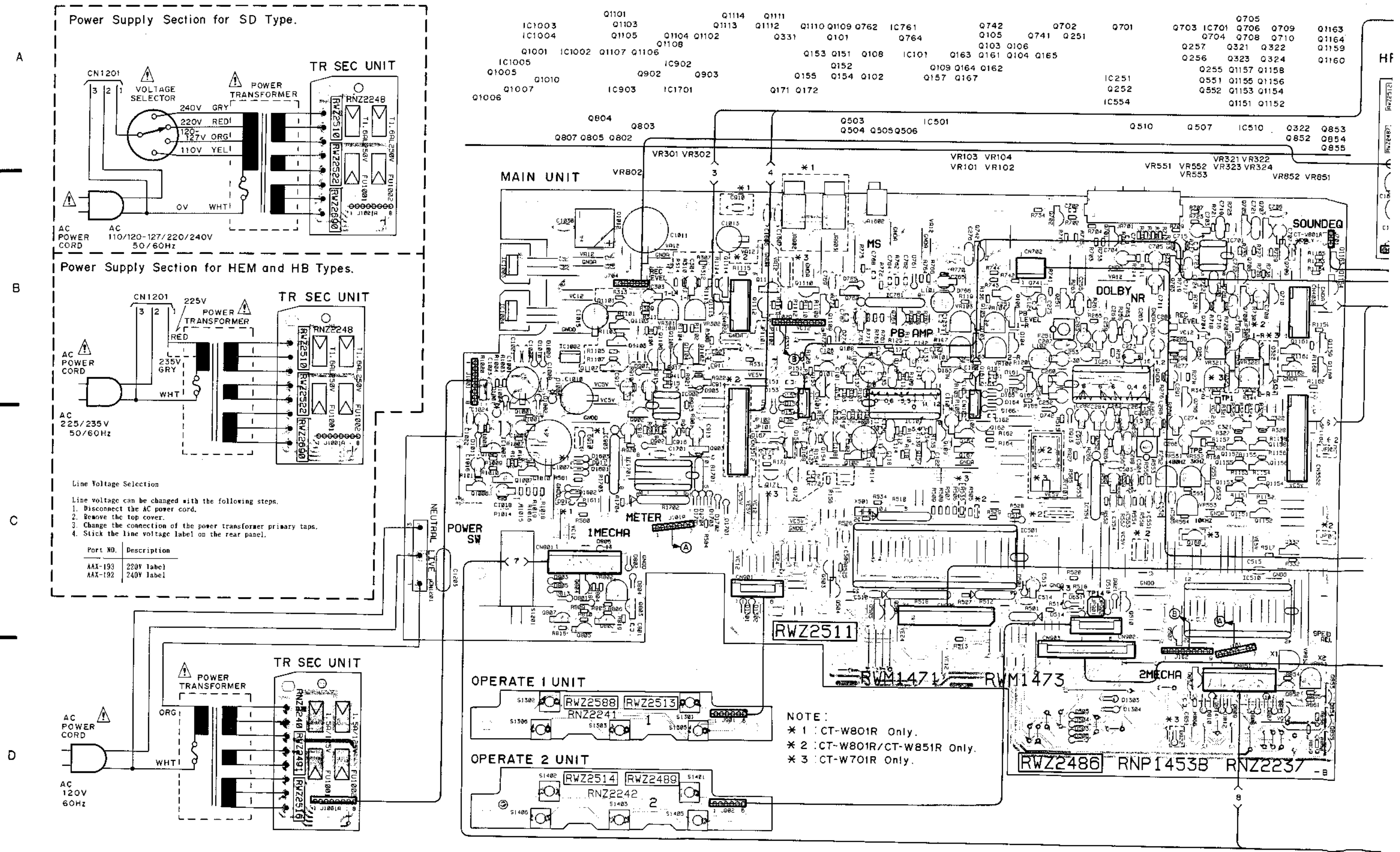

Power Supply Section for SD Type.

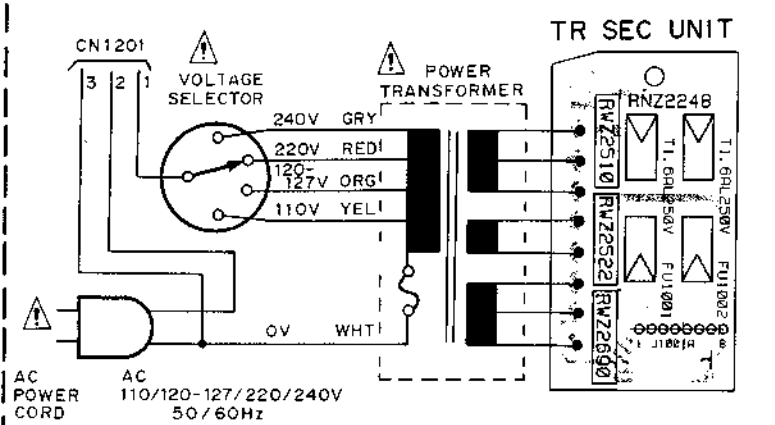

Power Supply Section for HEM and HB Types.

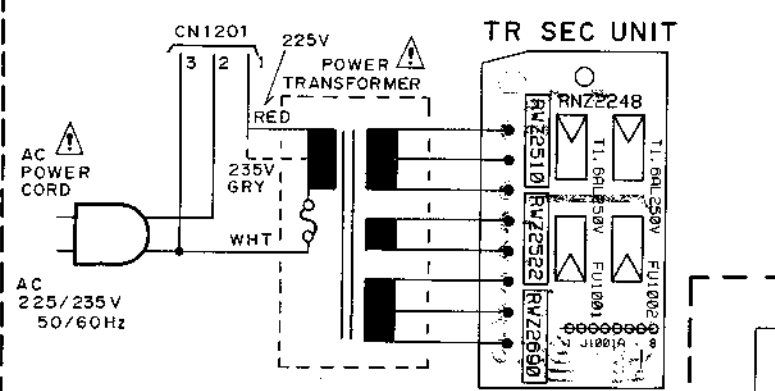

Line Voltage Selection
 Line voltage can be changed with the following steps.
 1. Disconnect the AC power cord.
 2. Remove the top cover.
 3. Change the connection of the power transformer primary taps.
 4. Stick the line voltage label on the rear panel.

Port NO.	Description
AAX-193	220V label
AAX-192	240V label

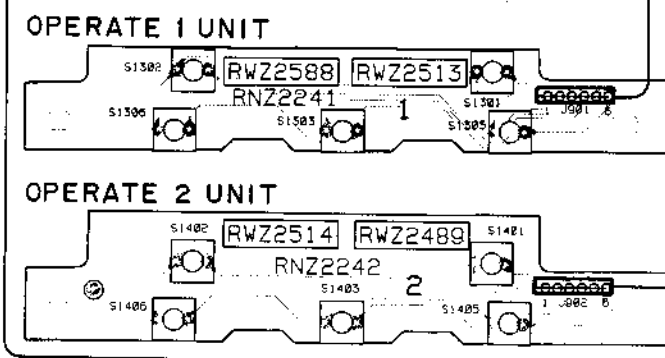
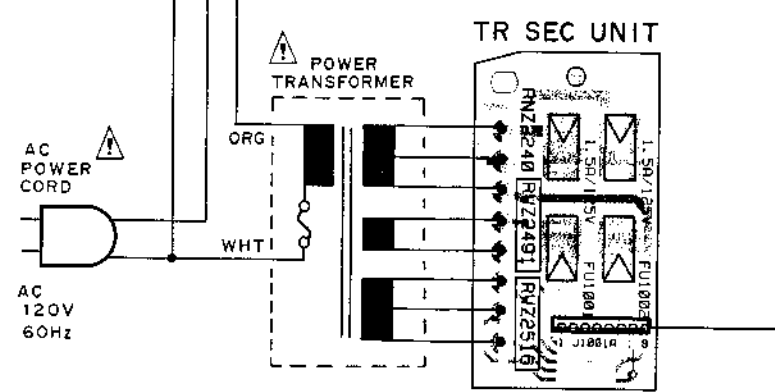

NOTE:
 * 1 : CT-W801R Only.
 * 2 : CT-W801R/CT-W851R Only.
 * 3 : CT-W701R Only.

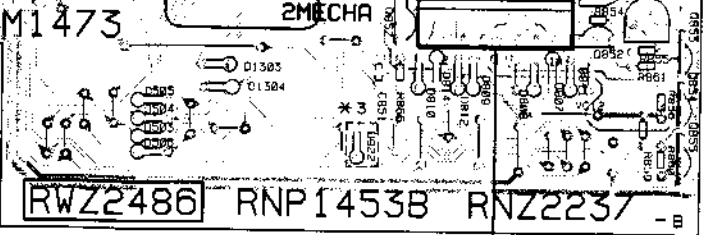

Q705
Q1 Q706 Q709 Q1163
Q4 Q708 Q710 Q1164
Q321 Q322 Q1159
Q323 Q324 Q1160
Q1157 Q1158
Q1155 Q1156
Q1153 Q1154
Q1151 Q1152

IC510 Q322 Q853
Q852 Q854
Q855

R321 VR322
R323 VR324
VR852 VR851

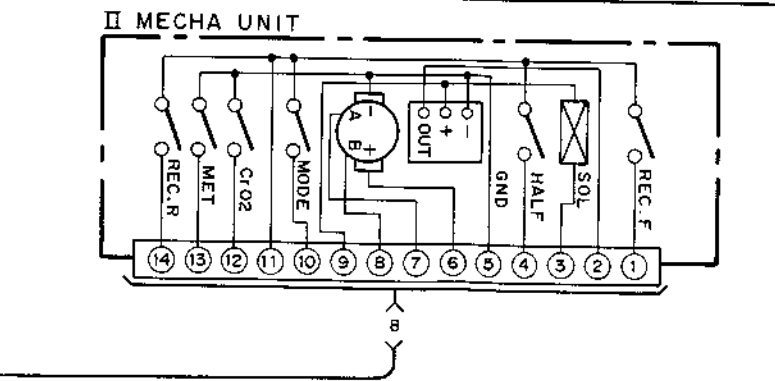
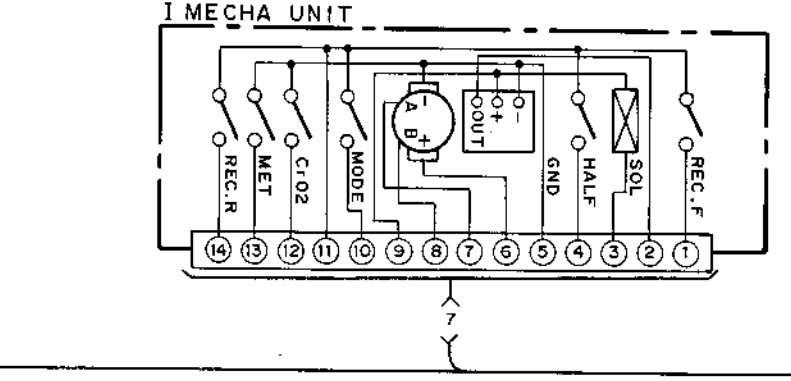
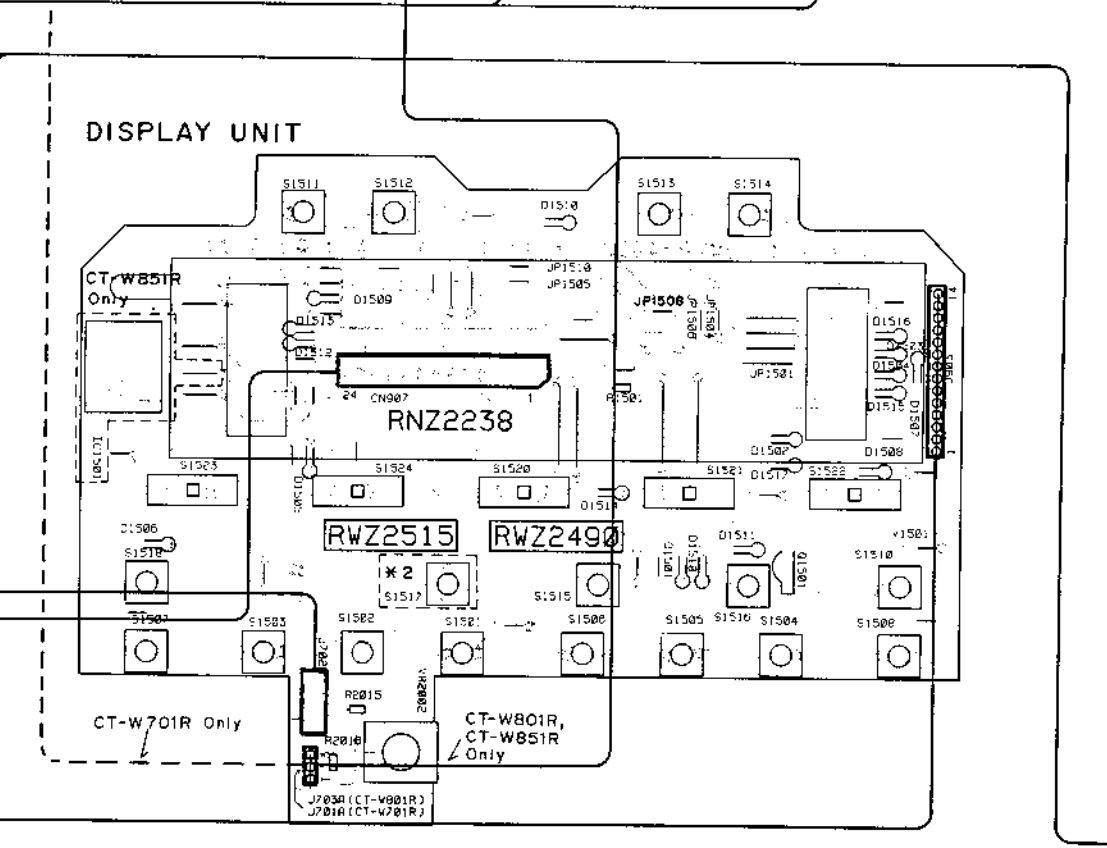
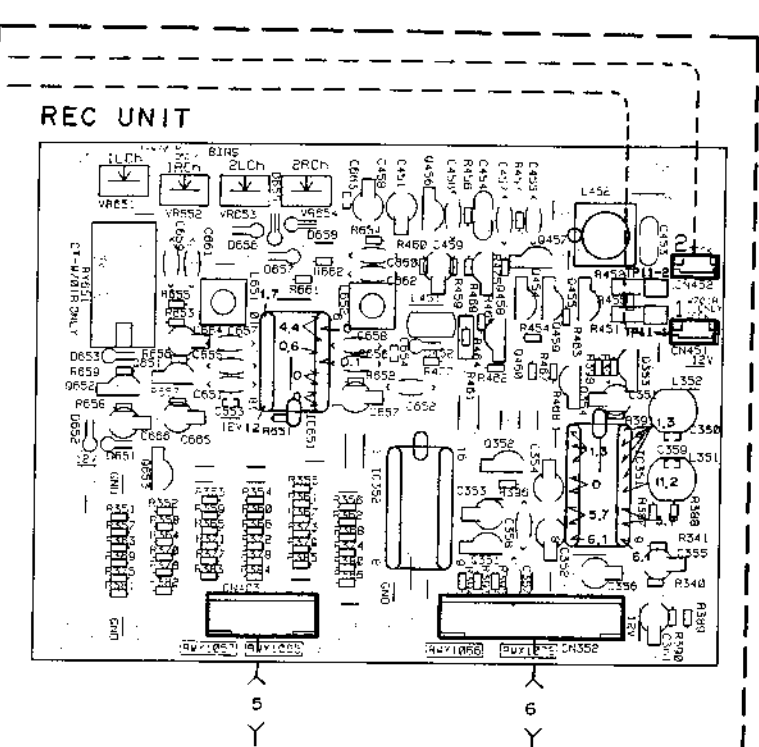
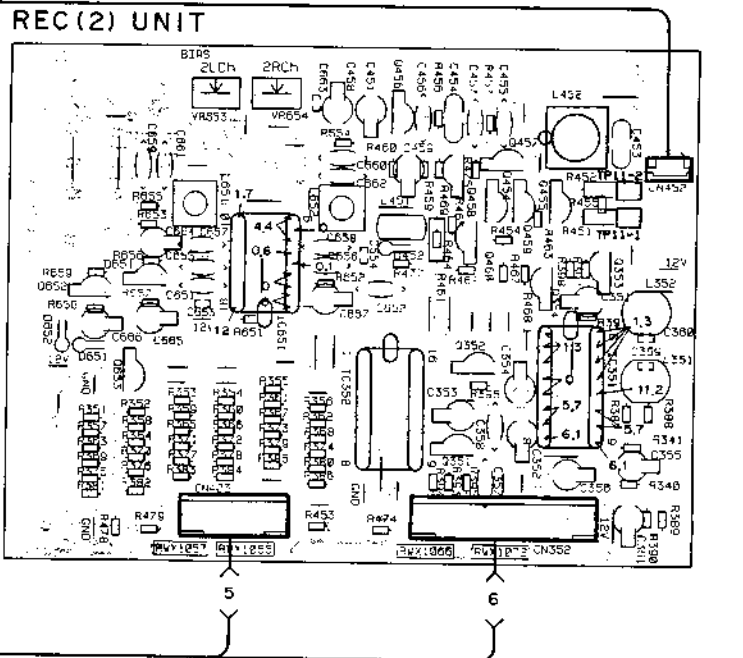
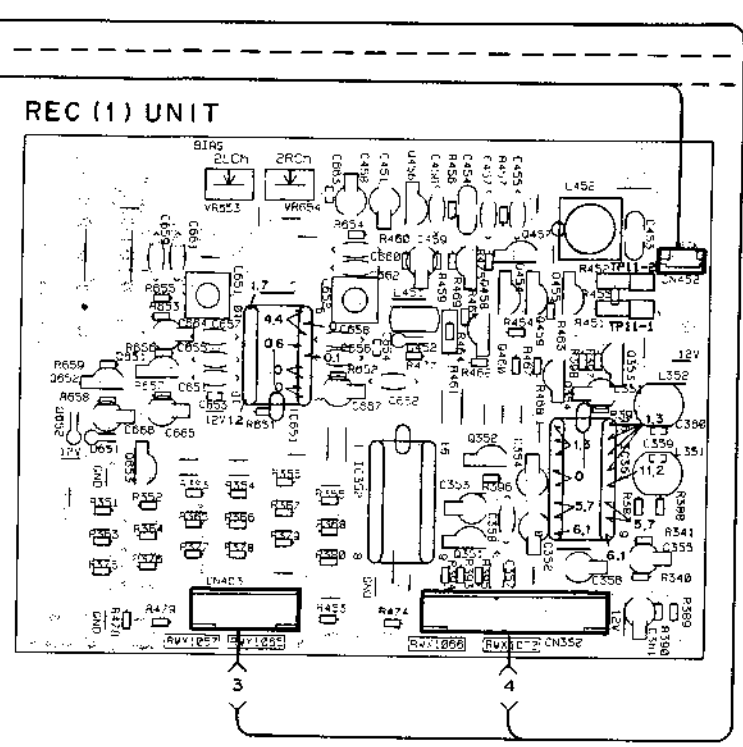
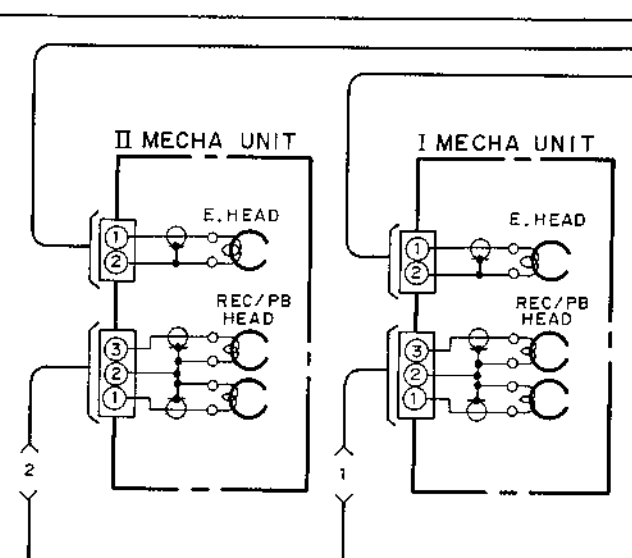
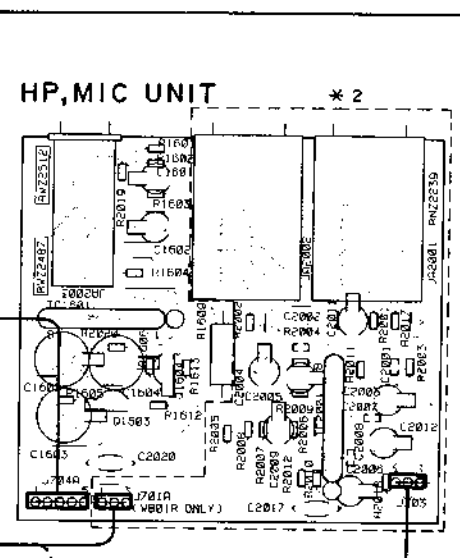
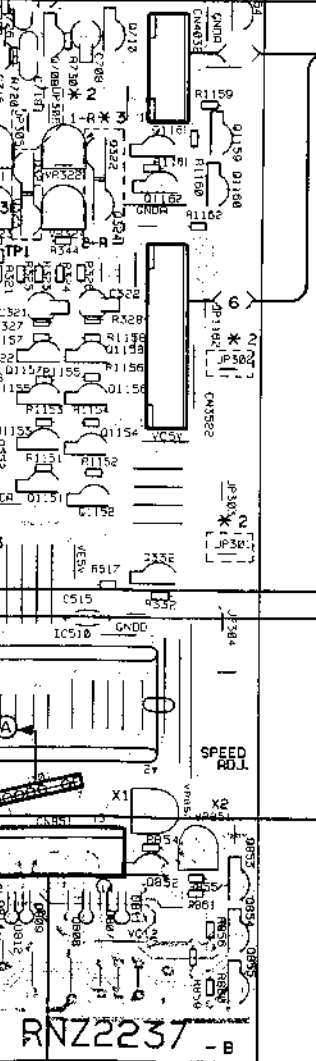

CT-W701R Only.

PCB pattern diagram indication	Corresponding unit symbol	Part name	PC B. pattern diagram indication	Corresponding part symbol	Part name
		Resistor			Ceramic capacitor
		Capacitor			Mylar capacitor
		Capacitor			Siwell capacitor
		Diode			Electrolytic capacitor (Non-polarized)
		Diode			Electrolytic capacitor (Polarized)
		LED			Electrolytic capacitor (Po anodes)
		Variable capacitor			Power capacitor
		Variable capacitor			Semi-fixed resistor
		Switch			Resistor array
		Inductor			Resistor
		Coil			Resonator
		Transformer			Transistor
		Filter			

1. The PCB connection diagram is viewed from the parts mounted side.
 2. The parts which have been mounted on the board can be selected with those shown with the corresponding wiring symbols listed in the above table.
 3. The capacitor terminal marked with (-) shows negative terminal.
 4. The diode marked with (C) shows cathode side.
 5. The resistor is shown marked with (R) shows resistor.

A
B
C
D

1 CT-W801R AND CT-W851R

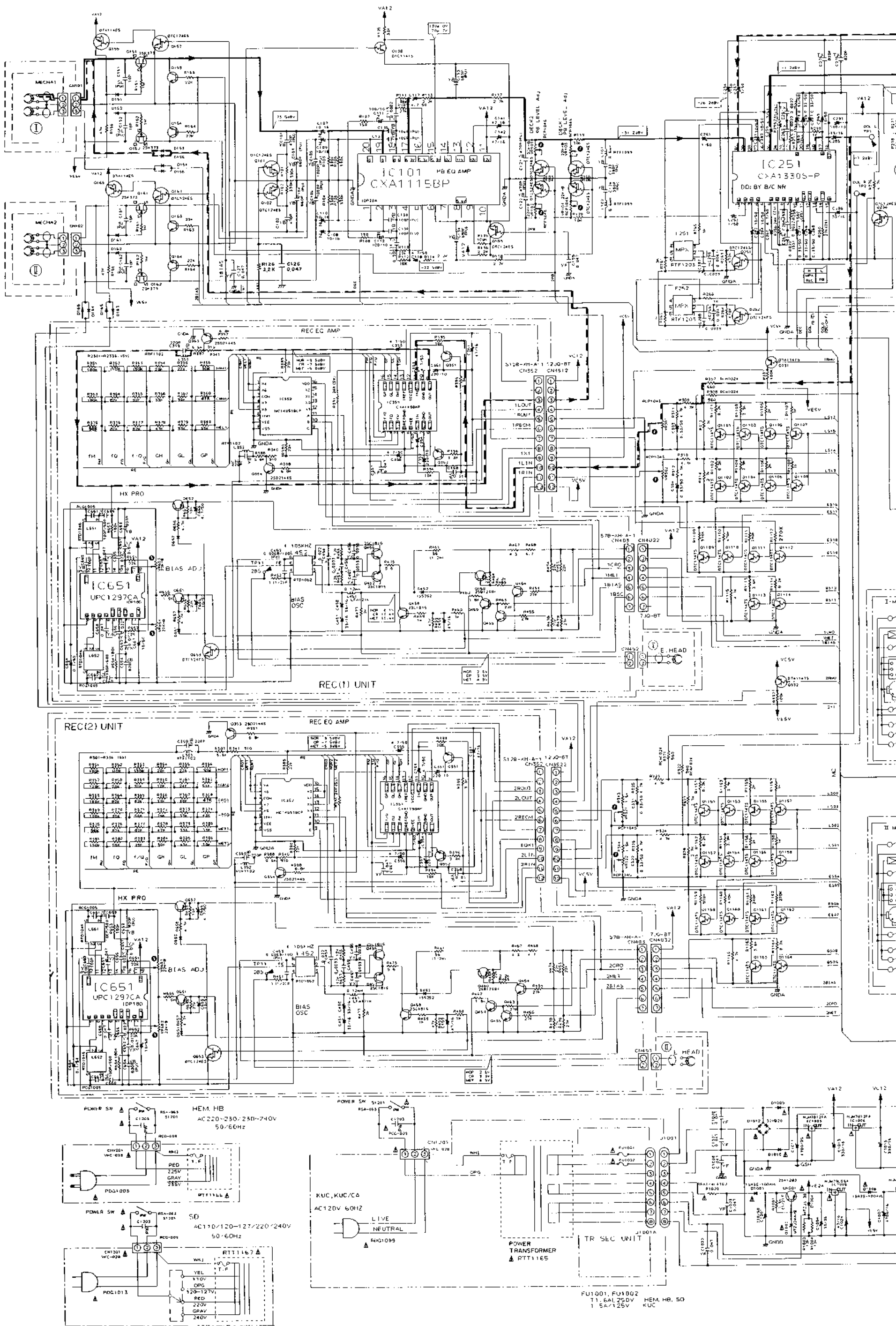

B
C
D
E
F

1 2 3 4

4 3 4

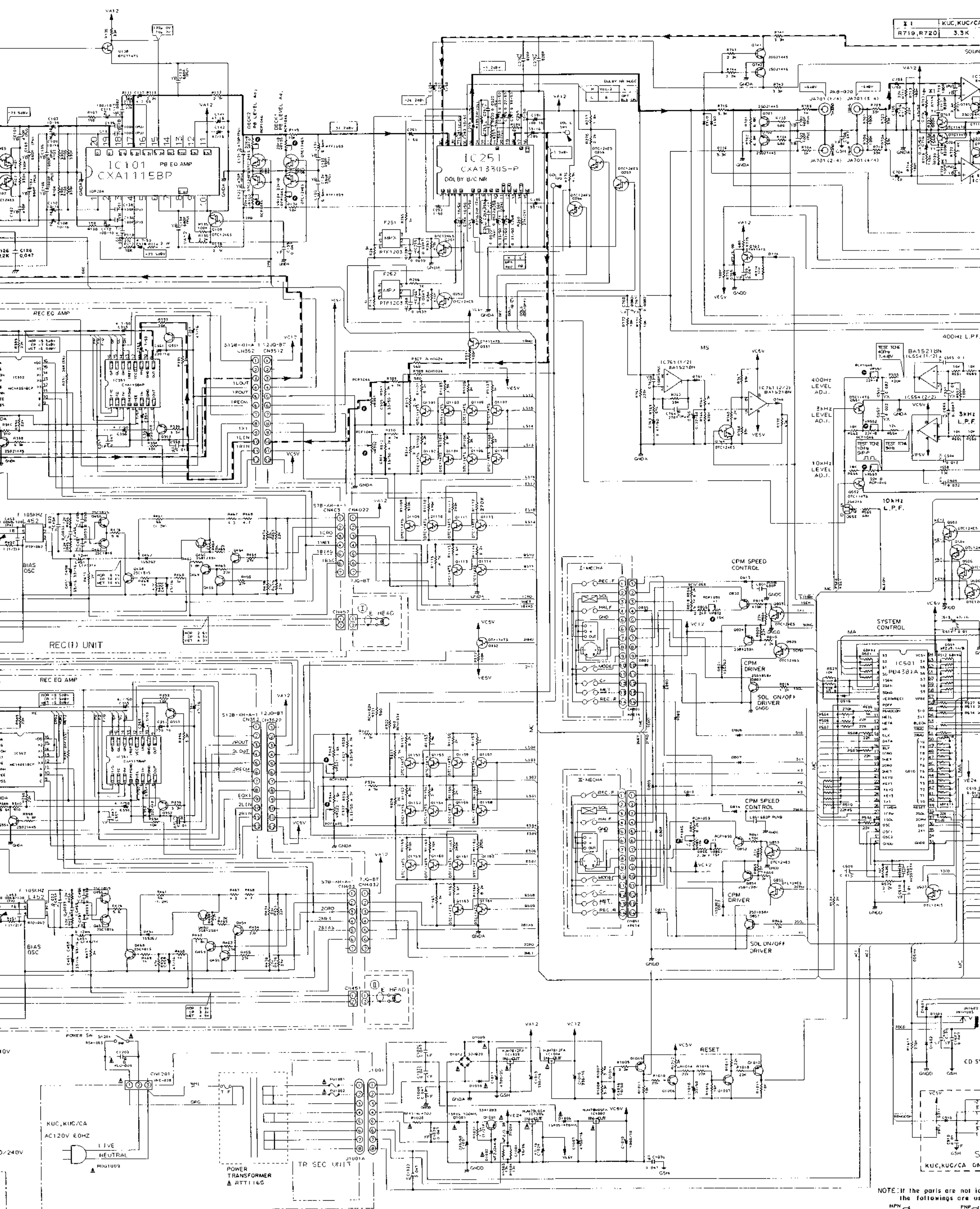

1 KUC, KUC/CA
R719, R720 3.3K

NOTE: If the parts are not in the following are used:
NPN 2SC3311A PNP

FU1001, FU1002
T1, 6AL250V HEM, 1H, 50
1 SA-125V KUC

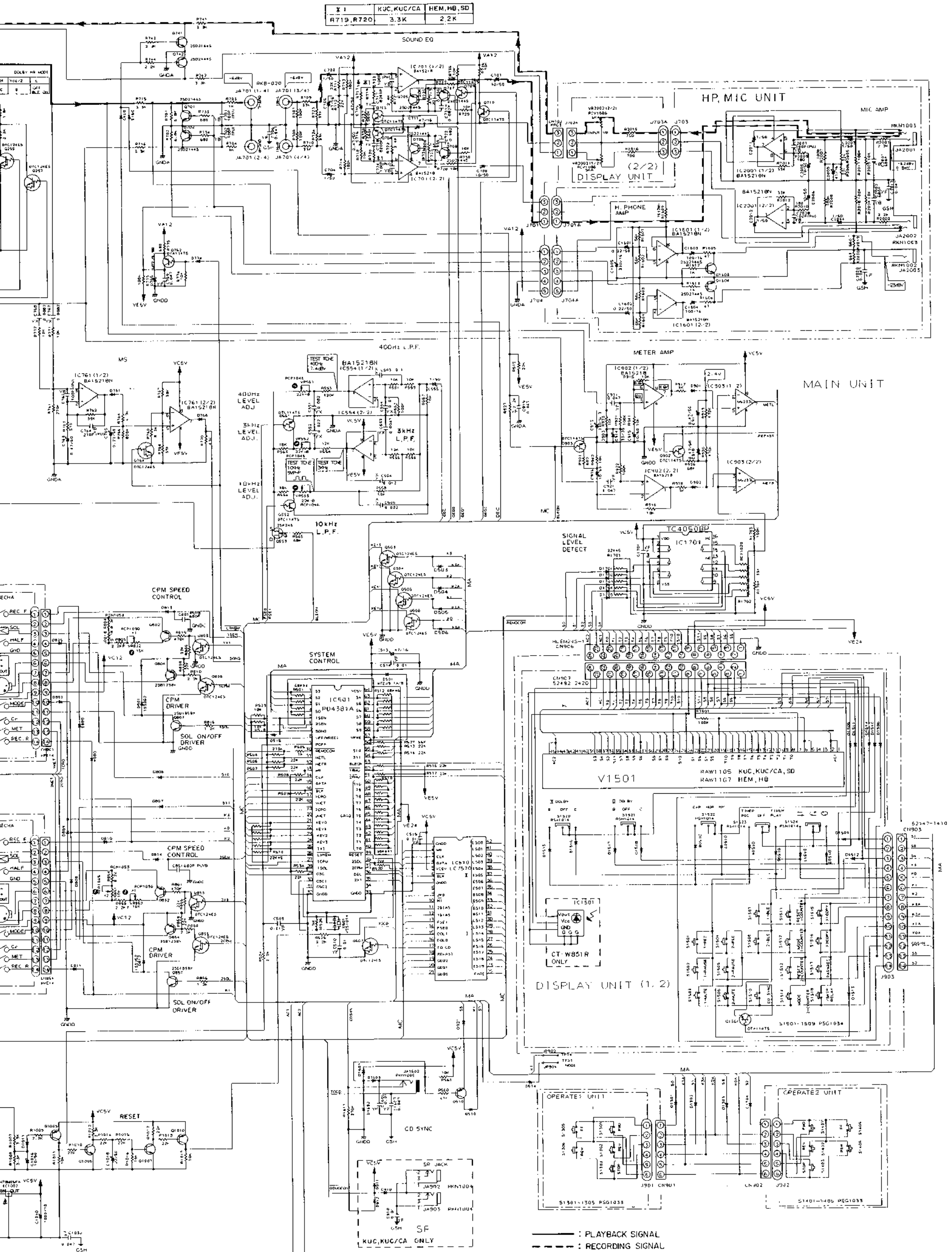

NOTE: If the parts are not identified in the diagram the followings are used.

NPN \circ 2SC3311A PNP \circ 2SA1309A \blacktriangle 1SS254

— : PLAYBACK SIGNAL
 - - - : RECORDING SIGNAL
 \blacktriangle : MEASUREMENT POINT

A
B
C
D
E
F

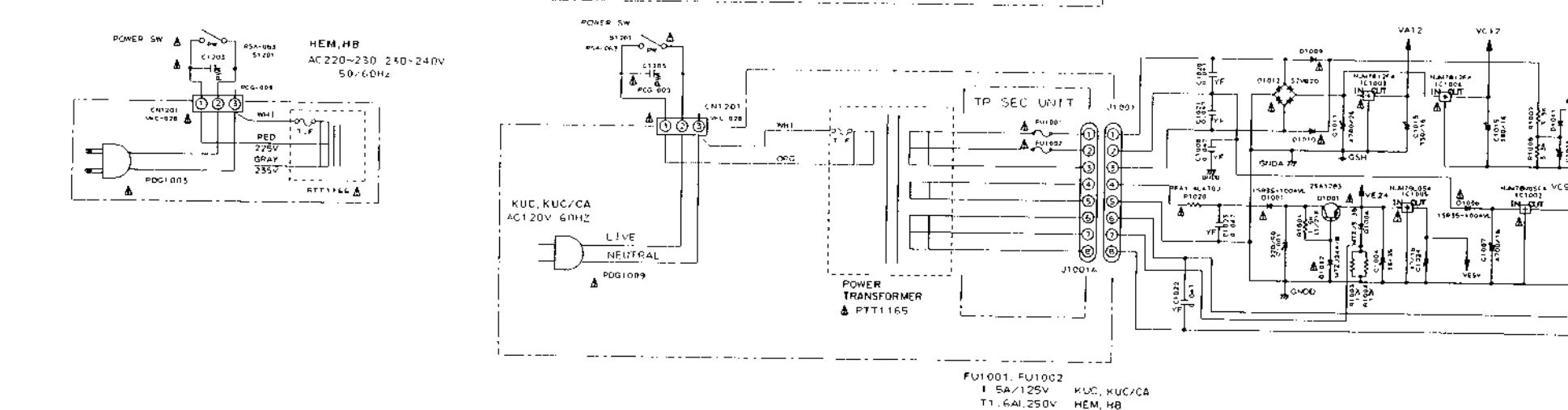
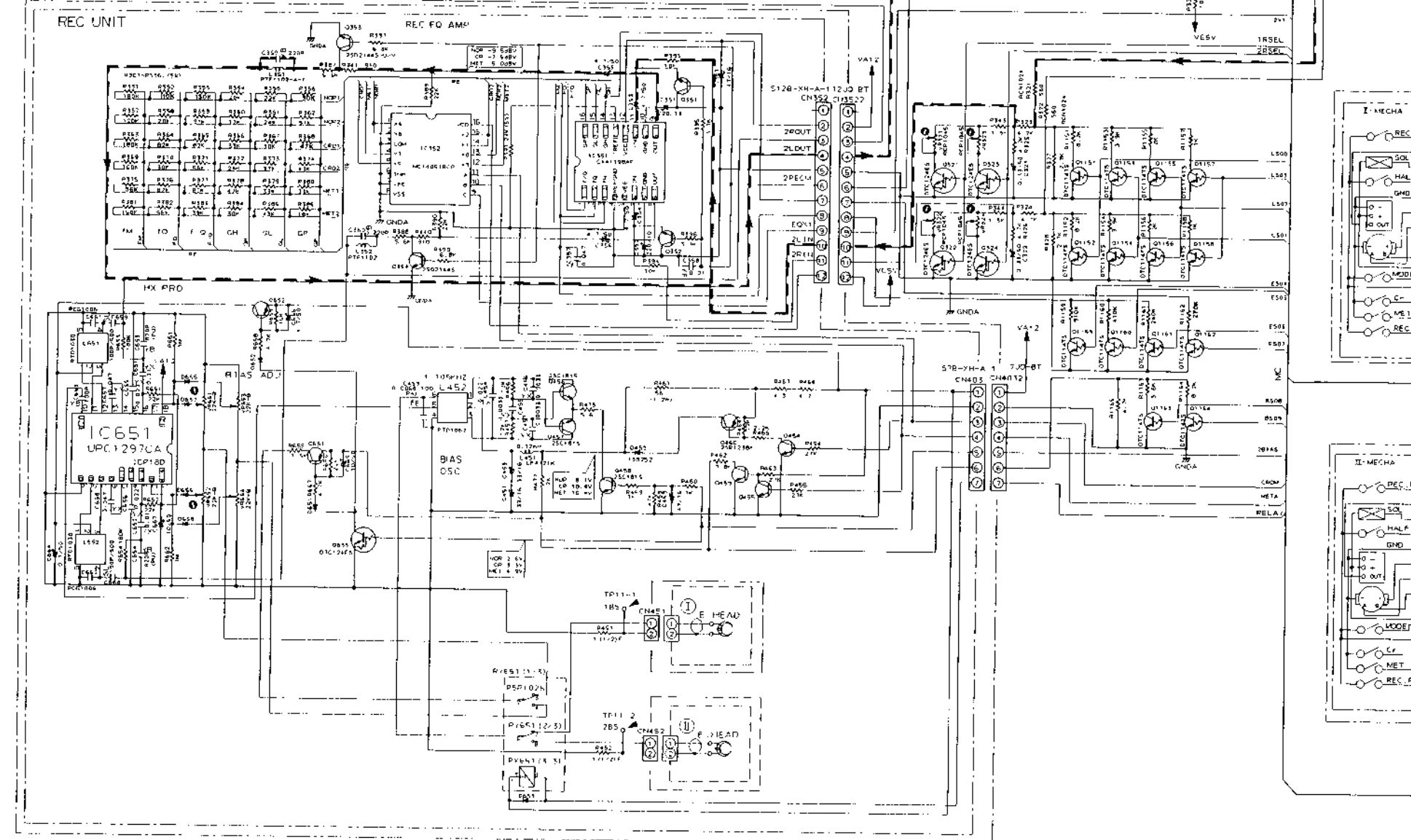
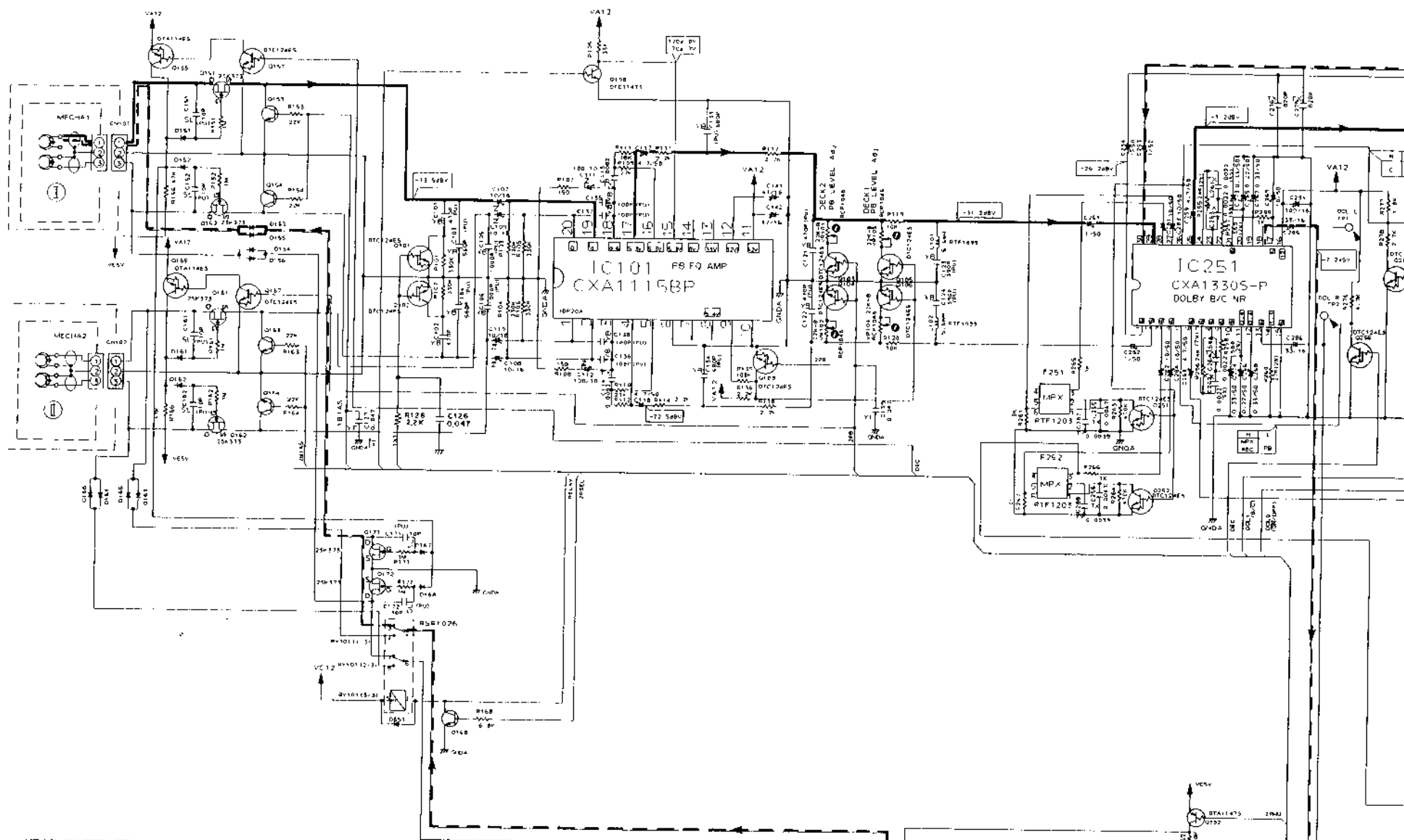

FU1001, FU1002
 T1 5A/125V KUC, KUC/CA
 T1 6A/250V HEM, HB

R719, R720	KUC 3.3K	HEM, HB 2.2K
------------	-------------	-----------------

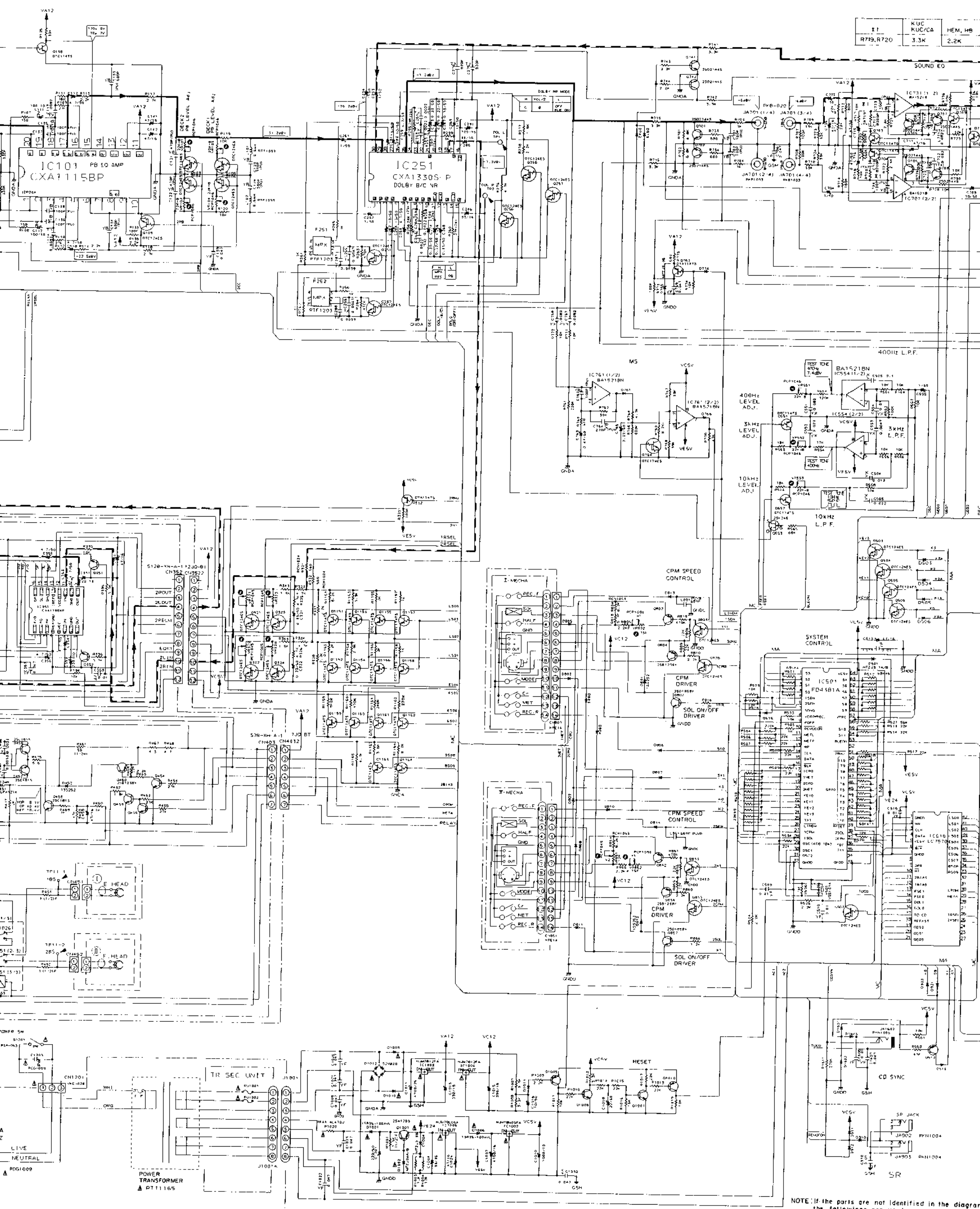

FU1001, FU1002
1.5A/125V KUC, KUC/CA
11 6AL250V HEM, HB

NOTE: If the parts are not identified in the diagram the followings are used.
NPN 2SC3311A PNP 2SA1309A 1SS

11	KUC R719, R720	HEM, HB 5.3K 2.2K
----	-------------------	-------------------------

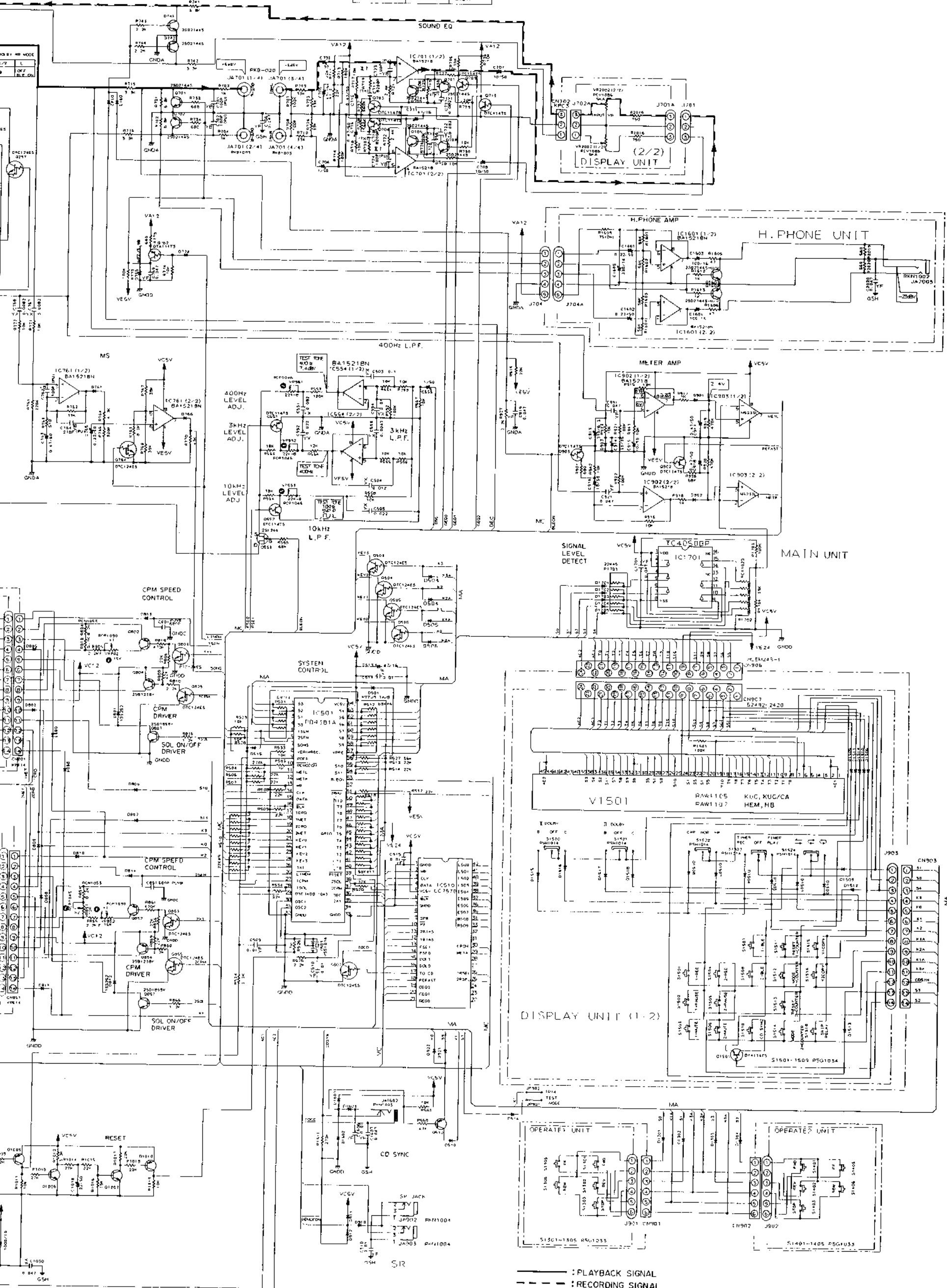

NOTE: If the parts are not identified in the diagram the followings are used.

2SC3311A
 2SA1309A
 1SS254

- : PLAYBACK SIGNAL
- - - : RECORDING SIGNAL
- ▲ : MEASUREMENT POINT

0151 0155
 025 0153 0154
 021 0152 0156
 022 0151 0158
 023 0234
 0231 0235
 024 0108 0110
 025 0108 0109
 026 0108 0109
 027 0108 0109
 028 0108 0109
 029 0108 0109
 030 0108 0109
 031 0108 0109
 032 0108 0109
 033 0108 0109
 034 0108 0109
 035 0108 0109
 036 0108 0109
 037 0108 0109
 038 0108 0109
 039 0108 0109
 040 0108 0109
 041 0108 0109
 042 0108 0109
 043 0108 0109
 044 0108 0109
 045 0108 0109
 046 0108 0109
 047 0108 0109
 048 0108 0109
 049 0108 0109
 050 0108 0109

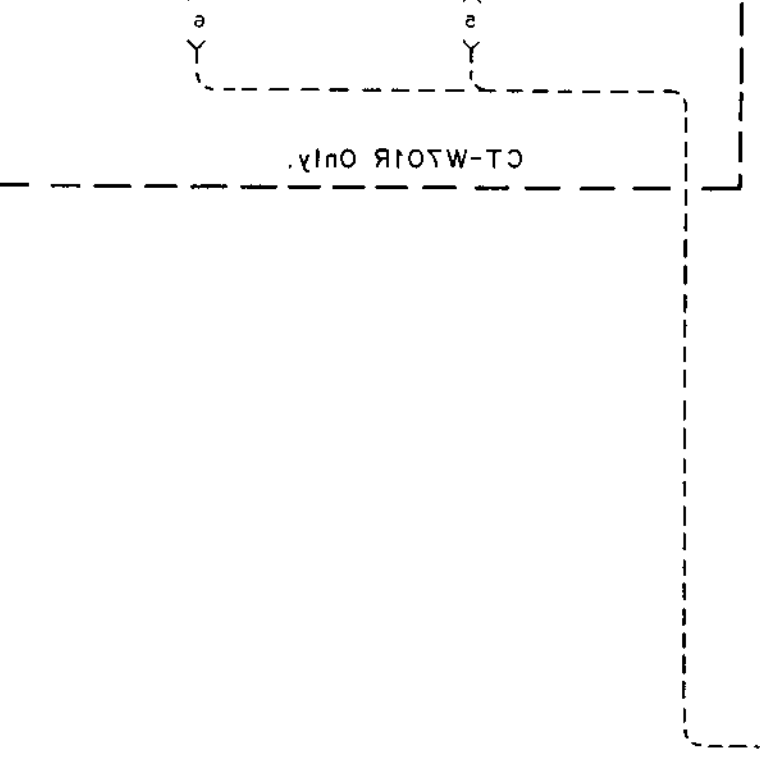
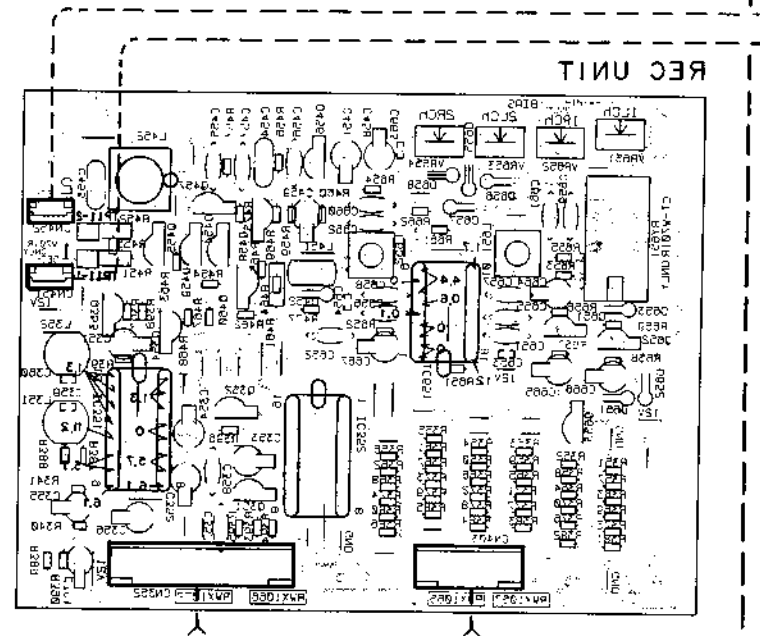
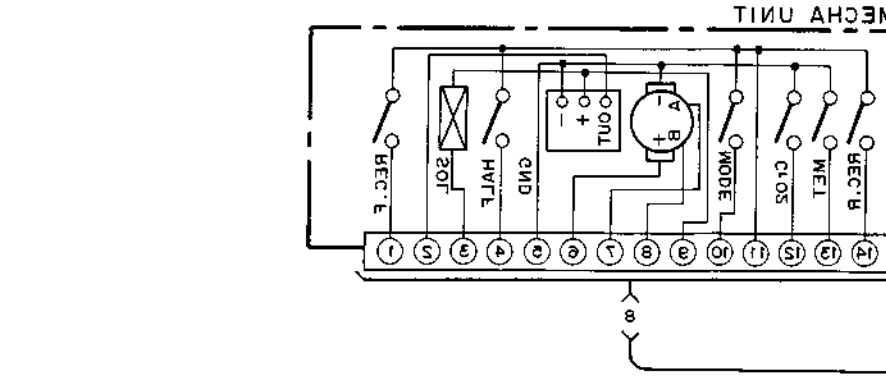
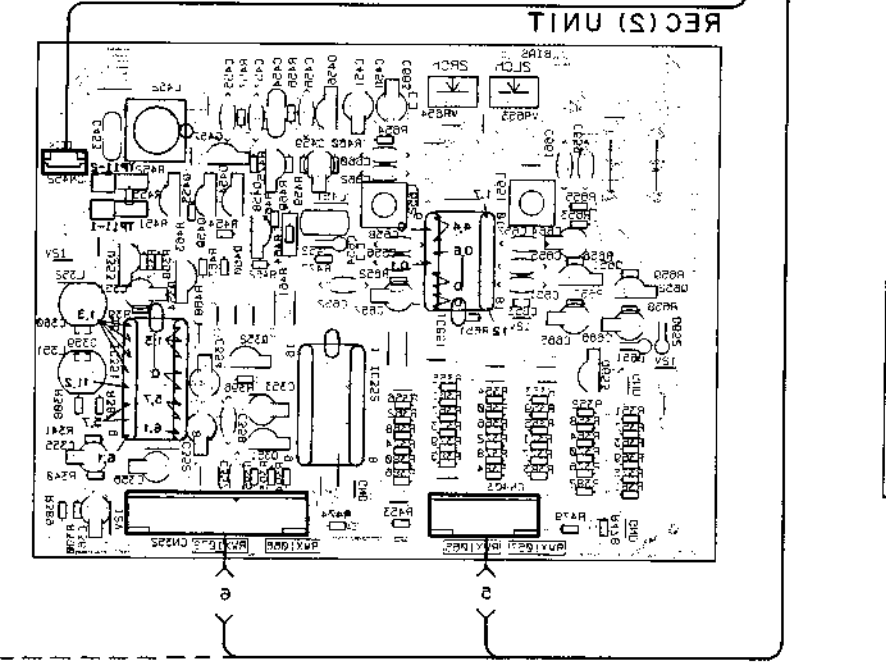
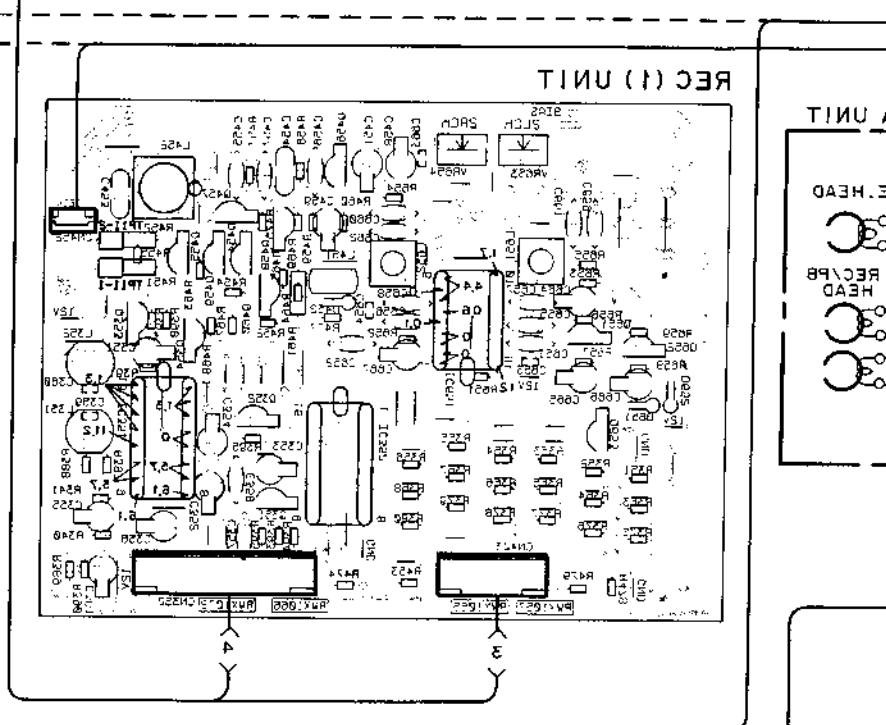
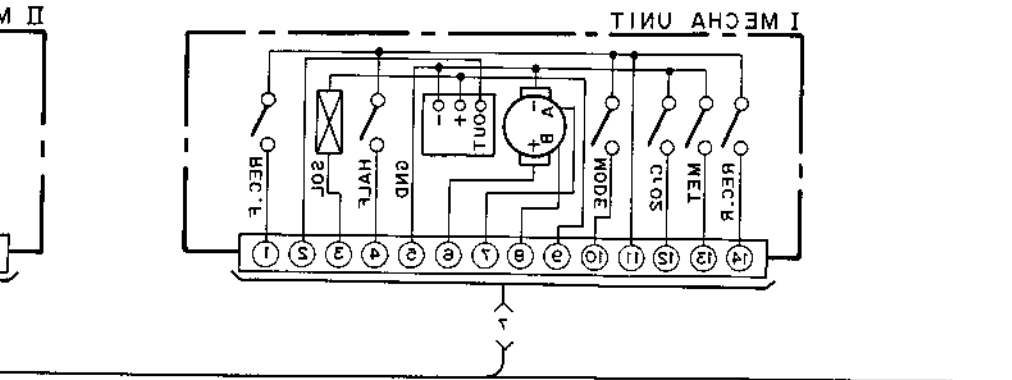
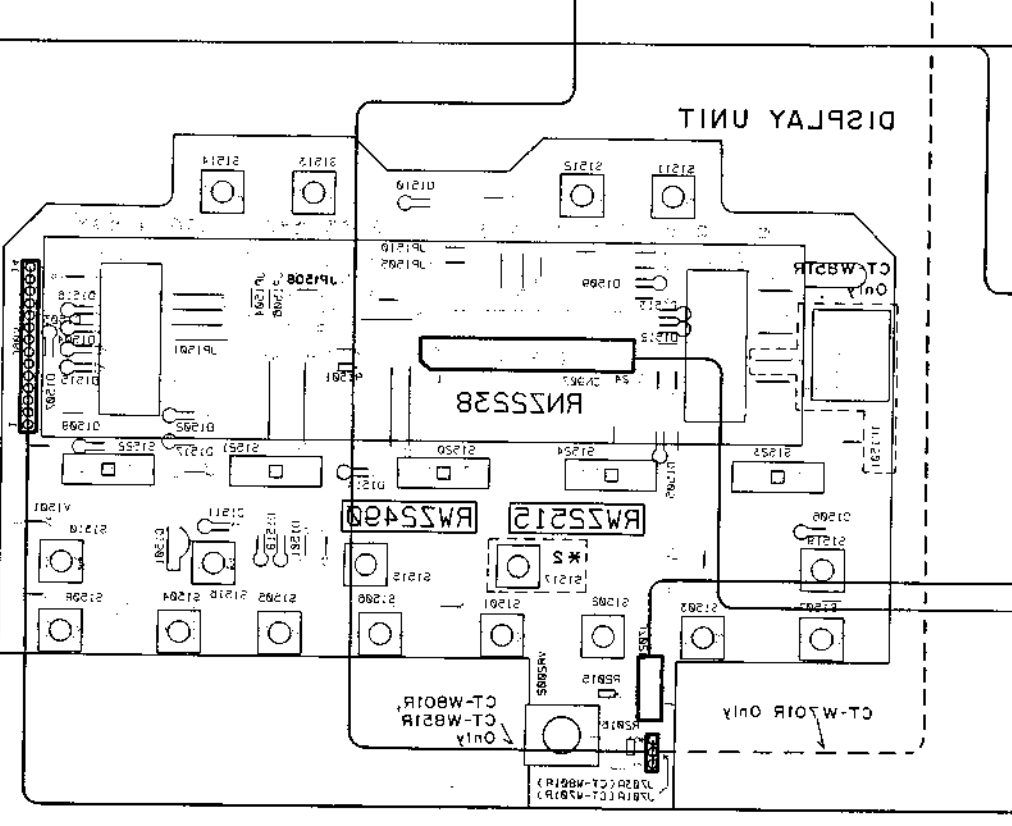
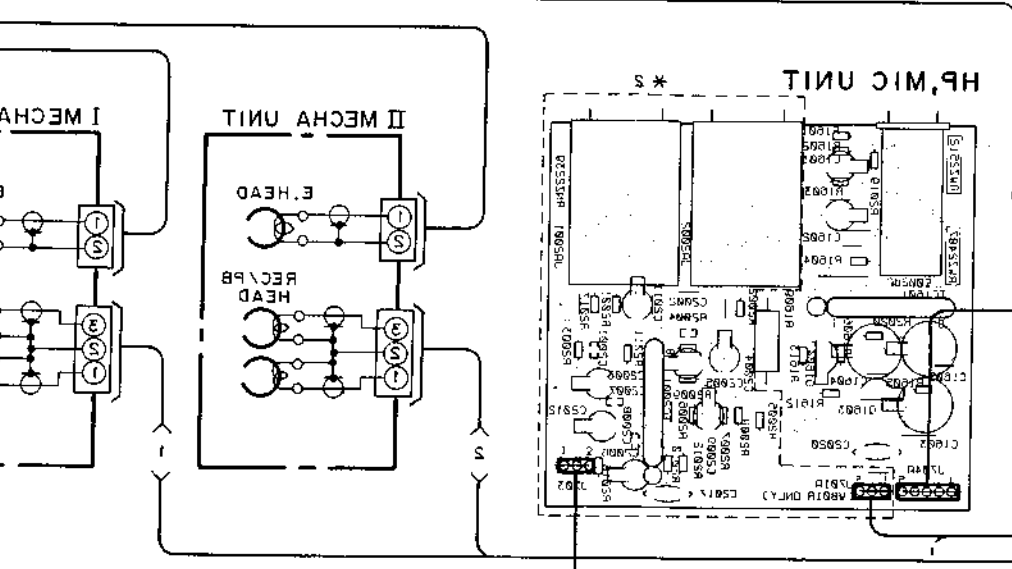
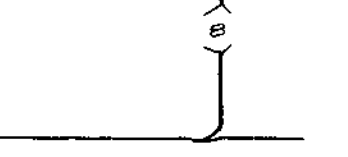
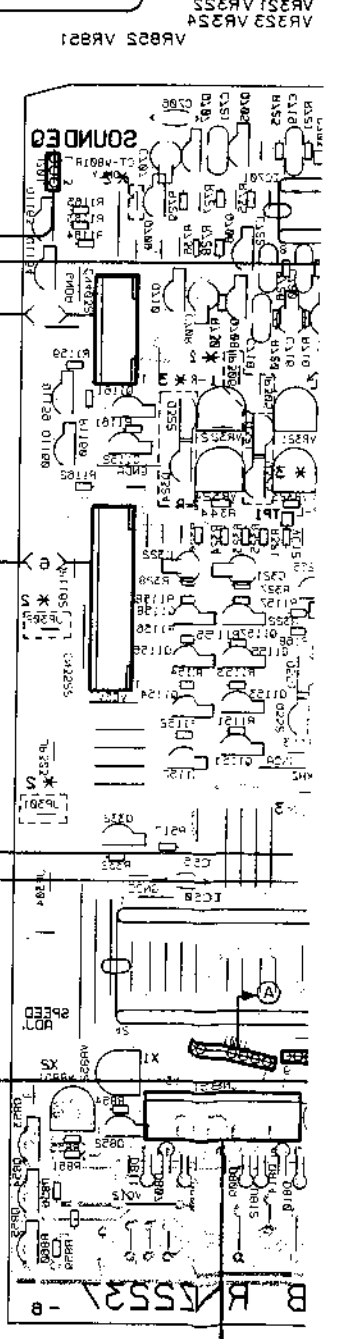

CT-W801R, CT-W821R, CT-W301R

CT-W801R, CT-W821R, CT-W301R

2. PCB CONNECTIONS DIAGRAM

• View from soldering side

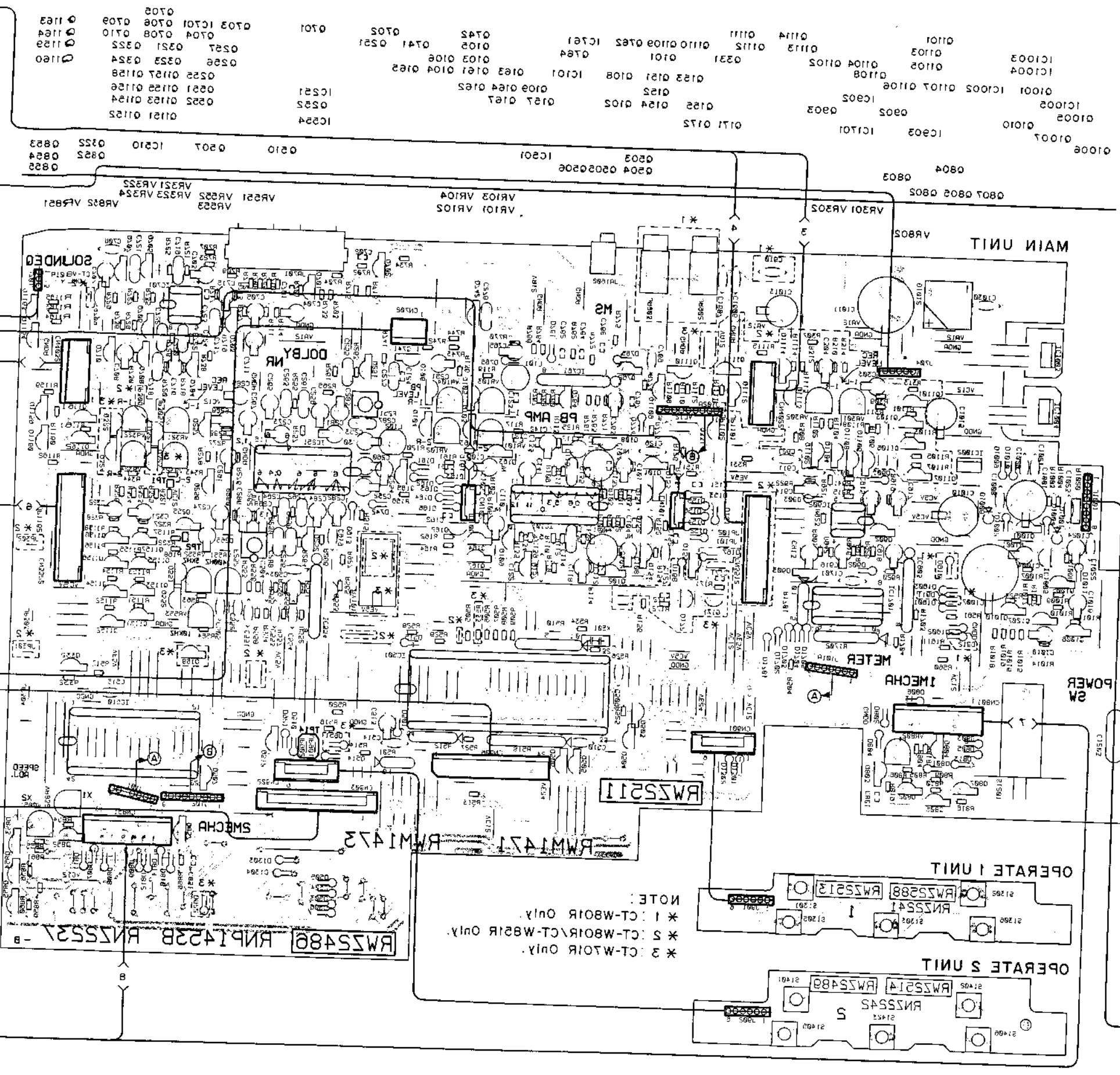
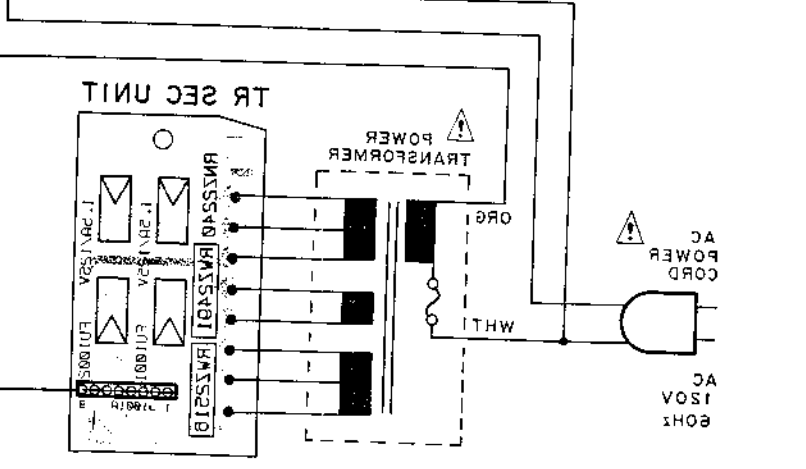
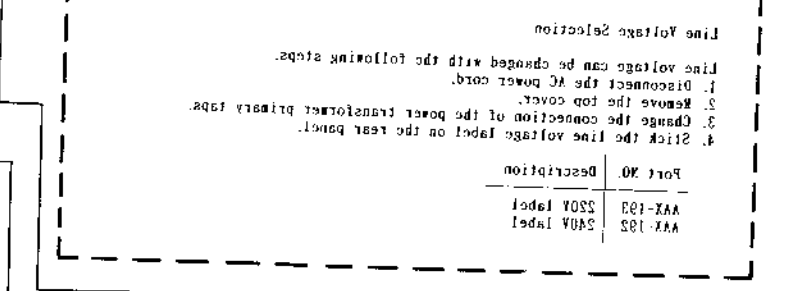
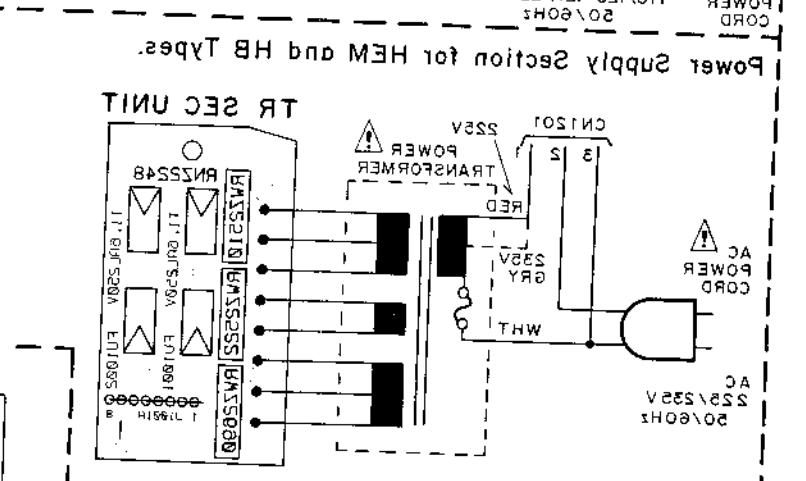
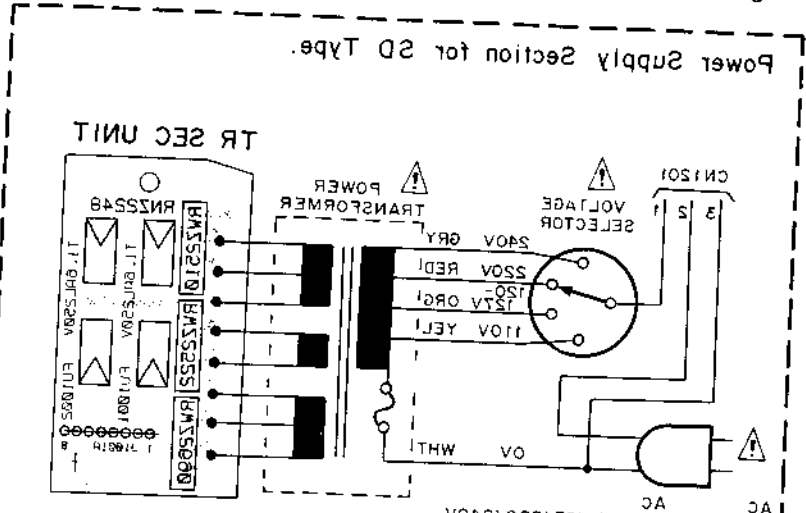

NOTE:
 * 1: CT-W801R Only.
 * 2: CT-W801R/CT-W81R Only.
 * 3: CT-W201R Only.

01006 01007 01010 01011 01012 01013 01014 01015 01016 01017 01018 01019 01020 01021 01022 01023 01024 01025 01026 01027 01028 01029 01030 01031 01032 01033 01034 01035 01036 01037 01038 01039 01040 01041 01042 01043 01044 01045 01046 01047 01048 01049 01050 01051 01052 01053 01054 01055 01056 01057 01058 01059 01060 01061 01062 01063 01064 01065 01066 01067 01068 01069 01070 01071 01072 01073 01074 01075 01076 01077 01078 01079 01080 01081 01082 01083 01084 01085 01086 01087 01088 01089 01090 01091 01092 01093 01094 01095 01096 01097 01098 01099 01100 01101 01102 01103 01104 01105 01106 01107 01108 01109 01110 01111 01112 01113 01114 01115 01116 01117 01118 01119 01120 01121 01122 01123 01124 01125 01126 01127 01128 01129 01130 01131 01132 01133 01134 01135 01136 01137 01138 01139 01140 01141 01142 01143 01144 01145 01146 01147 01148 01149 01150 01151 01152 01153 01154 01155 01156 01157 01158 01159 01160 01161 01162 01163 01164 01165 01166 01167 01168 01169 01170 01171 01172 01173 01174 01175 01176 01177 01178 01179 01180 01181 01182 01183 01184 01185 01186 01187 01188 01189 01190 01191 01192 01193 01194 01195 01196 01197 01198 01199 01200

A
B
C
D

6. BLOCK DIAGRAM

CT-W801R, CT-W851R

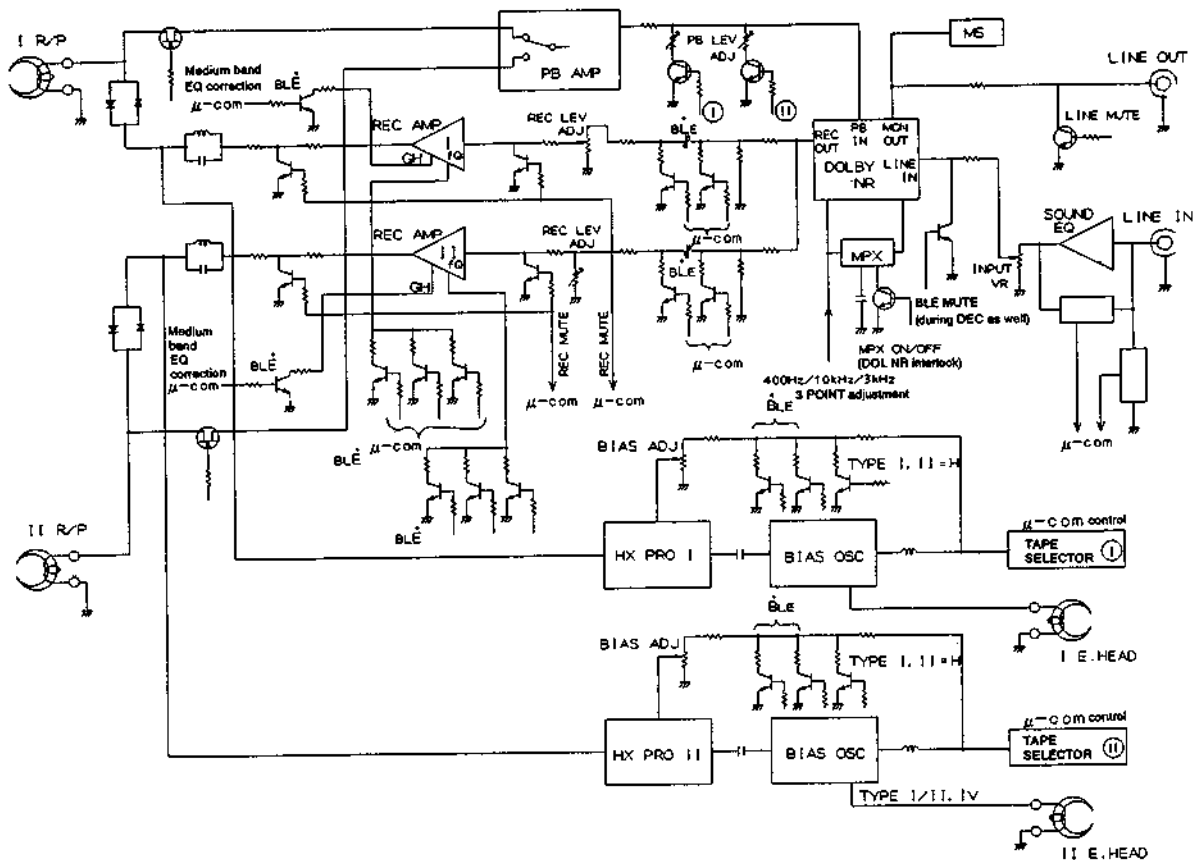

CT-W701R

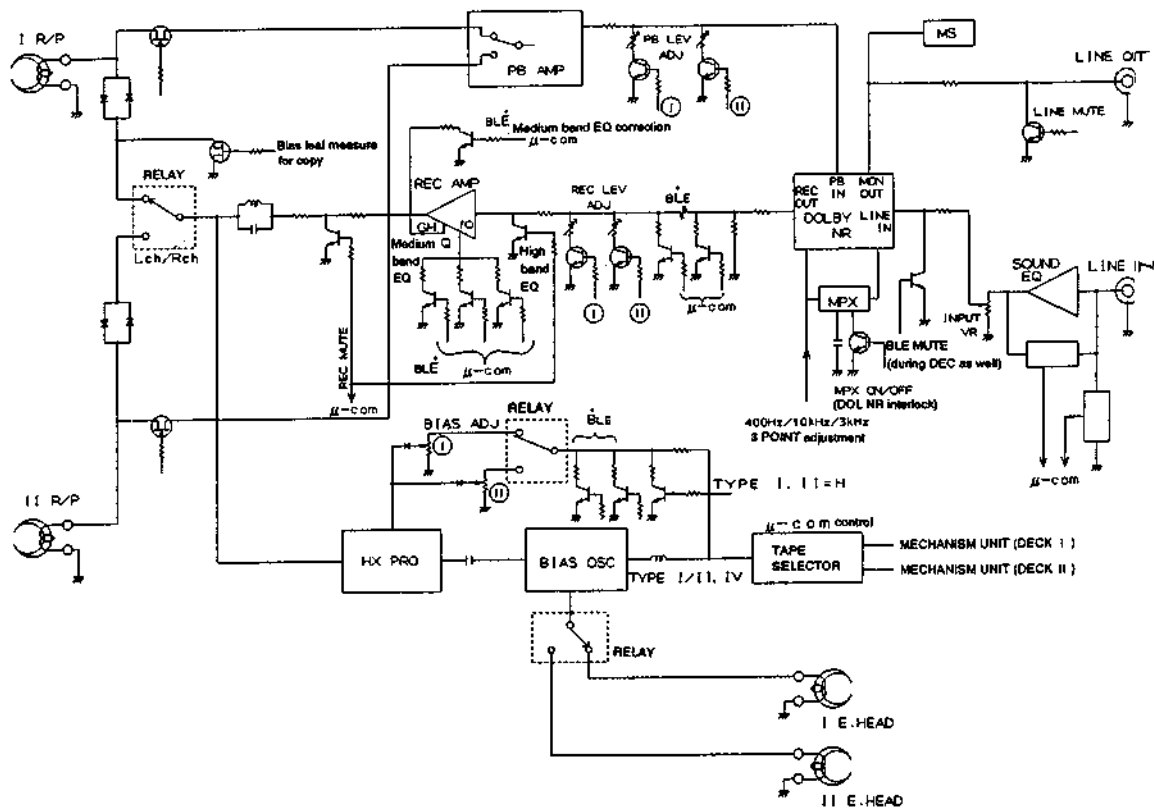

7. PCB PARTS LIST

● CT-W801R/KUC, KUC/CA and CT-W701R/KUC, KUC/CA types

NOTES:

- Parts marked by "NSP" are generally unavailable because they are not in our Master Spare Parts List.
- Parts marked by "⊙" are not always kept in stock. Their delivery time may be longer than usual or they may be unavailable.
- The Δ mark found on some component parts indicates the importance of the safety factor of the part. Therefore, when replacing, be sure to use parts of identical designation.
- When ordering resistors, first convert resistance values into code form as shown in the following examples.

Ex.1 When there are 2 effective digits (any digit apart from 0), such as 560 ohm and 47k ohm (tolerance is shown by J=5%, and K=10%)

560 Ω	$\rightarrow 56 \times 10^1 \rightarrow 561$	RD1/4PS	5	6	1	J
47k Ω	$\rightarrow 47 \times 10^3 \rightarrow 473$	RD1/4PS	4	7	3	J
0.5 Ω	$\rightarrow 0R5$	RN2H	0	R	5	K
1 Ω	$\rightarrow 010$	RS1P	0	1	0	K

Ex.2 When there are 3 effective digits (such as in high precision metal film resistors).

5.62k Ω	$\rightarrow 562 \times 10^1 \rightarrow 5621$	RN1/4SR	5	6	2	1	F
----------------	------------------------------------------------	---------	---	---	---	---	---

NOTE: (*1): CT-W801R/KUC, KUC/CA (*2): CT-W701R/KUC, KUC/CA

Mark	No.	Description	Part No.	Mark	No.	Description	Part No.
------	-----	-------------	----------	------	-----	-------------	----------

LIST OF ASSEMBLIES

● (*1)

NSP	REC(1)UNIT	RWX1065
NSP	REC(2)UNIT	RWX1066

⊙	MOTHER UNIT	RWM1471
NSP	├MAIN UNIT	RWZ2486
NSP	├HP, MIC UNIT	RWZ2487
NSP	├OPERATE SW(1) UNIT	RWZ2488
NSP	├OPERATE SW(2) UNIT	RWZ2489
NSP	├DISPLAY UNIT	RWZ2490
NSP	└TR SEC UNIT	RWZ2491

● (*2)

NSP	REC UNIT	RWX1057
-----	----------	---------

⊙	MOTHER UNIT	RWM1473
NSP	├MAIN UNIT	RWZ2511
NSP	├HP UNIT	RWZ2512
NSP	├OPERATE SW(1) UNIT	RWZ2513
NSP	├OPERATE SW(2) UNIT	RWZ2514
NSP	├DISPLAY UNIT	RWZ2515
NSP	└TR SEC UNIT	RWZ2516

REC (1) UNIT

SEMICONDUCTORS

IC351 REC EQUALIZER IC	CXA1198AP
IC352	MC14051BCP
IC651 DOLBY HX PRO IC	UPC1297CA
Q351, 352 TRANSISTOR	2SC3311A
Q353, 354 TRANSISTOR	2SD2144S

Q454, 455 TRANSISTOR	2SC3311A
Q456-458 TRANSISTOR	2SC1815
Q459 TRANSISTOR	2SC3311A
Q460 TRANSISTOR	2SB1238X
Q651, 652 TRANSISTOR	2SA1309A

Q653 TRANSISTOR	DTC124ES
D452 DIODE	1SS252
D651, 652 DIODE	1SS254

COILS/TRANSFORMERS

L351, 352 COIL	RTF1102
L451 RADIAL INDUCTOR	LFA121K
L452 COIL	RTD1062
L651, 652 COIL	RTD1046

CAPACITORS

C351, 352 ELECT. CAPACITOR	CEAS221M10
C353-356 ELECT. CAPACITOR	CEAS4R7M50
C357 CERAMIC CAPACITOR	CGCYF473Z50
C358 CERAMIC CAPACITOR	CKCYF103Z50
C359, 360 AXIAL CAPACITOR	CKPUYB221K50

C361 ELECT. CAPACITOR	CEAS470M16
C451 ELECT. CAPACITOR	CEAS330M16
C453 CAPACITOR	CQPA682J100
C454 AUDIO FILM CAPACITOR	CFTXA223J50
C455-457 CERAMIC CAPACITOR	CGCYX332K25

C458 ELECT. CAPACITOR	CEAS330M16
C459 ELECT. CAPACITOR	CEAS470M16
C651, 652 CERAMIC CAPACITOR	CGCYX103K25
C653, 654 AXIAL CAPACITOR	CKPUYB821K50
C655, 656 CERAMIC CAPACITOR	CGCYX223K25

C657, 658 CERAMIC CAPACITOR	CGCYF473Z50
C659, 660 CERAMIC CAPACITOR	CCCSL101K500
C661, 662 CERAMIC CAPACITOR	RCG1005
C663 AXIAL CAPACITOR	CKPUYB101K50
C664 ELECT. CAPACITOR	CEASR10M50

C665 ELECT. CAPACITOR	CEAS100M50
C666 ELECT. CAPACITOR	CEAS4R7M50
C667 ELECT. CAPACITOR	CEAS100M50

RESISTORS

R340, 341 CARBONFILM RESISTOR	RD1/6PM□□□J
R351-356 CARBONFILM RESISTOR	RD1/6PM□□□J
R363-368 CARBONFILM RESISTOR	RD1/6PM□□□J
R375-380 CARBONFILM RESISTOR	RD1/6PM□□□J
R387-391 CARBONFILM RESISTOR	RD1/6PM□□□J
R393-398 CARBONFILM RESISTOR	RD1/6PM□□□J
R452 CARBONFILM RESISTOR	RD1/2LF□□□J

Mark	No.	Description	Part No.	Mark	No.	Description	Part No.
	R453-457	CARBONFILM RESISTOR	RD1/6PM□□□J		C659, 660	CERAMIC CAPACITOR	CCCSL101K500
	R459, 460	CARBONFILM RESISTOR	RD1/6PM□□□J		C661, 662	CERAMIC CAPACITOR (#1)	RCG1005
	R461	CARBONFILM RESISTOR	RD1/2LF□□□J		C661, 662	CERAMIC CAPACITOR (#2)	RCG1006
	R462-465	CARBONFILM RESISTOR	RD1/6PM□□□J		C663	AXIAL CAPACITOR	CKPUYB101K50
	R467-469	CARBONFILM RESISTOR	RD1/6PM□□□J		C664	ELECT. CAPACITOR	CEASR10M50
	R474, 475	CARBONFILM RESISTOR	RD1/6PM□□□J		C665	ELECT. CAPACITOR	CEAS100M50
	R477-479	CARBONFILM RESISTOR	RD1/6PM□□□J		C666	ELECT. CAPACITOR	CEAS4R7M50
	R651-659	CARBONFILM RESISTOR	RD1/6PM□□□J		C667	ELECT. CAPACITOR	CEAS100M50
	VR653, 654	VR	VRTB6HS223	RESISTORS			
OTHERS					R340, 341	CARBONFILM RESISTOR	RD1/6PM□□□J
	CN352		S12B-XH-A-1		R351-391	CARBONFILM RESISTOR	RD1/6PM□□□J
	CN403		S7B-XH-A-1		R393-398	CARBONFILM RESISTOR	RD1/6PM□□□J
REC (2) UNIT(* 1)					R451	CARBONFILM RESISTOR (*2)	RD1/2LF□□□J
REC UNIT(* 2)					R452	CARBONFILM RESISTOR	RD1/2LF□□□J
SEMICONDUCTORS					R453	CARBONFILM RESISTOR (*1)	RD1/6PM□□□J
	IC351	REC EQUALIZER IC	CXA1198AP		R454-457	CARBONFILM RESISTOR	RD1/6PM□□□J
	IC352		MC14051BCP		R459, 460	CARBONFILM RESISTOR	RD1/6PM□□□J
	IC651	DOLBY HX PRO IC	UPC1297CA		R461	CARBONFILM RESISTOR	RD1/2LF□□□J
	Q351, 352	TRANSISTOR	2SC3311A		R462-465	CARBONFILM RESISTOR	RD1/6PM□□□J
	Q353, 354	TRANSISTOR	2SD2144S		R467-469	CARBONFILM RESISTOR	RD1/6PM□□□J
	Q454, 455	TRANSISTOR	2SC3311A		R474	CARBONFILM RESISTOR (*1)	RD1/6PM□□□J
	Q456-458	TRANSISTOR	2SC1815		R475	CARBONFILM RESISTOR	RD1/6PM□□□J
	Q459	TRANSISTOR	2SC3311A		R477	CARBONFILM RESISTOR	RD1/6PM□□□J
	Q460	TRANSISTOR	2SB1238X		R478, 479	CARBONFILM RESISTOR (*1)	RD1/6PM□□□J
	Q651, 652	TRANSISTOR	2SA1309A		R651-659	CARBONFILM RESISTOR	RD1/6PM□□□J
	Q653	TRANSISTOR	DTC124ES		R661, 662	CARBONFILM RESISTOR (*2)	RD1/6PM□□□J
	D452	DIODE	1SS252		VR651, 652	VR (*2)	VRTB6HS223
	D651, 652	DIODE	1SS254		VR653, 654	VR	VRTB6HS223
	D653, 655-658	DIODE (*2)	1SS254	OTHERS			
COILS/TRANSFORMERS					CN352		S12B-XH-A-1
	L351, 352	COIL	RTF1102		CN403		S7B-XH-A-1
	L451	RADIAL INDUCTOR	LFA121K	MAIN UNIT			
	L452	COIL	RTD1062	SEMICONDUCTORS			
	L651, 652	COIL (*1)	RTD1046		IC101	PB-EQ AMP IC	CXA1115BP
	L651, 652	COIL (*2)	RTD1030		IC251	DOLBY B/C IC	CXA133S-P
RELAYS					IC501	MCU	PD43811
	RY651	RELAY (*2)	RSR1026		IC510	FL STATIC DRIVER IC	LC7570
CAPACITORS					IC554	IC	BA15211N
	C351, 352	ELECT. CAPACITOR	CEAS221M10		IC701	OP-AMP IC	BA15211
	C353-356	ELECT. CAPACITOR	CEAS4R7M50		IC761	IC	BA15211N
	C357	CERAMIC CAPACITOR	CGCYF473Z50		IC902	OP-AMP IC	BA15211
	C358	CERAMIC CAPACITOR	CKCYF103Z50		IC903	DUAL-COMPARATOR IC	MS233L
	C359, 360	AXIAL CAPACITOR	CKPUYB221K50	△	IC1002	REGULATOR IC	NJM78M5FA
	C361	ELECT. CAPACITOR	CEAS470M16	△	IC1003, 1004	REGULATOR IC	NJM7815FA
	C451	ELECT. CAPACITOR	CEAS330M16	△	IC1005	REGULATOR IC	NJM79L5A
	C453	CAPACITOR	QCPA682J100		IC1701	CMOS LOGIC IC	TC4050JP
	C454	AUDIO FILM CAPACITOR	CFTXA223J50		Q101-106	TRANSISTOR	DTC124S
	C455-457	CERAMIC CAPACITOR	CGCYX332K25		Q108	DIGITAL TRANSISTOR	DTC114S
	C458	ELECT. CAPACITOR	CEAS330M16		Q109	TRANSISTOR	DTC124S
	C459	ELECT. CAPACITOR	CEAS470M16		Q151, 152	N-FET	2SK373
	C651, 652	CERAMIC CAPACITOR	CGCYX103K25		Q153, 154	TRANSISTOR	2SC331A
	C653, 654	AXIAL CAPACITOR	CKPUYB821K50		Q155	DIGITAL TRANSISTOR	DTA114S
	C655, 656	CERAMIC CAPACITOR	CGCYX223K25		Q157	TRANSISTOR	DTC124S
	C657, 658	CERAMIC CAPACITOR	CGCYF473Z50		Q161, 162	N-FET	2SK373
					Q163, 164	TRANSISTOR	2SC331A

CT-W801R, CT-W701R

Mark	No.	Description	Part No.	Mark	No.	Description	Part No.
	Q165	DIGITAL TRANSISTOR	DTA114ES	△	D1001	DIODE	1SR35-100AVL
	Q167	TRANSISTOR	DTC124ES	△	D1002	ZENER DIODE	MTZJ24AA
	Q168	TRANSISTOR (*2)	2SC3311A		D1004	ZENER DIODE	MTZJ3, 3B
	Q171, 172	N-FET (*2)	2SK373	△	D1006	DIODE	1SR35-100AVL
	Q251, 252	TRANSISTOR	DTC124ES				
	Q255-257	TRANSISTOR	DTC124ES	△	D1009-1011	DIODE	1SS254
	Q321-324	TRANSISTOR (*2)	DTC124ES	△	D1012		S2VB20
	Q331	DIGITAL TRANSISTOR (*1)	DTA114TS		D1301-1304	DIODE	1SS254
	Q332	DIGITAL TRANSISTOR	DTA114TS		D1601-1603	DIODE	1SS254
	Q503-507	TRANSISTOR	DTC124ES		D1701-1705	DIODE	1SS254
	Q510	TRANSISTOR	2SA1309A	COILS/TRANSFORMERS			
	Q551, 552	DIGITAL TRANSISTOR	DTC114TS		L101, 102	COIL	RTF1099
	Q553	N-FET	2SK246		F251, 252	FILTER	RTF1203
	Q701, 702	TRANSISTOR	2SD2144S	RELAYS			
	Q703, 704	DIGITAL TRANSISTOR	DTC114TS		RY101	RELAY (*2)	RSR1026
	Q705-708	TRANSISTOR	2SD2144S	SWITCHES			
	Q709, 710	DIGITAL TRANSISTOR	DTC114TS	△	S1201	SWITCH	RSA-063
	Q741, 742	TRANSISTOR	2SD2144S	CAPACITORS			
	Q762	DIGITAL TRANSISTOR	DTA114TS		C101, 102	AXIAL CAPACITOR	CKPUYB471K50
	Q764	TRANSISTOR	DTC124ES		C103, 104	AXIAL CAPACITOR	CKPUYB561K50
	Q802	TRANSISTOR	2SA1309A		C105, 106	CERAMIC CAPACITOR	CKPUYB102K50
	Q803	TRANSISTOR	DTC124ES		C107-110	ELECT. CAPACITOR	CEANL100M16
	Q804	TRANSISTOR	2SB1238X		C111, 112	ELECT. CAPACITOR	CEANL101M10
	Q805	TRANSISTOR	DTC124ES		C113, 114	AUDIO FILM CAPACITOR	CFTXA822J50
	Q807	TRANSISTOR	2SD1858X		C117, 118	ELECT. CAPACITOR	CEAS4R7M50
	Q852	TRANSISTOR	2SA1309A		C121, 122	AXIAL CAPACITOR	CKPUYB471K50
	Q853	TRANSISTOR	DTC124ES		C123, 124	AXIAL CAPACITOR	CKPUYB391K50
	Q854	TRANSISTOR	2SB1238X		C126, 127	CERAMIC CAPACITOR	CGCYF473Z50
	Q855	TRANSISTOR	DTC124ES		C133, 134	AXIAL CAPACITOR	CKPUYB681K50
	Q857	TRANSISTOR	2SD1858X		C135-138	AXIAL CAPACITOR	CKPUYB101K50
	Q902, 903	DIGITAL TRANSISTOR	DTC114TS		C139	CERAMIC CAPACITOR	CGCYF473Z50
△	Q1001	TRANSISTOR	2SA1283		C141, 142	ELECT. CAPACITOR	CEAS470M16
	Q1005	TRANSISTOR	2SA1309A		C151, 152	AXIAL CAPACITOR	CCPUSL100J50
	Q1006, 1007	TRANSISTOR	2SC3311A		C161, 162	AXIAL CAPACITOR	CCPUSL100J50
	Q1010	TRANSISTOR	2SA1309A		C171, 172	AXIAL CAPACITOR (*2)	CCPUSL100J50
	Q1101-1114	DIGITAL TRANSISTOR (*1)	DTC114TS		C251-254	ELECT. CAPACITOR	CEAS010M50
	Q1151-1164	DIGITAL TRANSISTOR	DTC114TS		C255, 256	AUDIO FILM CAPACITOR	CFTXA472J50
	D151-156	DIODE	1SS254		C259, 260	ELECT. CAPACITOR	CEAS4R7M50
	D161-166	DIODE	1SS254		C261-264	AUDIO FILM CAPACITOR	CFTXA222J50
	D167, 168, 651, 922	DIODE (*2)	1SS254		C265, 266	ELECT. CAPACITOR	CEASR22M50
	D501	ZENER DIODE	MTZJ9, 1A		C267, 268	ELECT. CAPACITOR	CEASR33M50
	D503-506	DIODE	1SS254		C269	ELECT. CAPACITOR	CEAS100M50
	D510	DIODE	1SS254		C273, 274	ELECT. CAPACITOR	CEASR33M50
	D514, 515	DIODE	1SS254		C275, 276		CFTXA821J50
	D742	DIODE	1SS254		C281-284	ELECT. CAPACITOR	CEAS100M50
	D761	DIODE	1SS254		C285, 286	ELECT. CAPACITOR	CEAS330M16
	D765	ZENER DIODE	MTZJ3, 9B		C287, 288	AUDIO FILM CAPACITOR	CFTXA392J50
	D766	DIODE	1SS254		C291	ELECT. CAPACITOR	CEAS101M16
	D774	DIODE	1SS254		C303, 304	ELECT. CAPACITOR (*1)	CEASR33M50
	D801	DIODE	1SS252		C321, 322	ELECT. CAPACITOR	CEASR33M50
	D802-811	DIODE	1SS254		C503	CERAMIC CAPACITOR	CGCYX104K25
	D812	DIODE	1SS252		C504	CERAMIC CAPACITOR	CGCYX123K25
	D813, 814	DIODE	1SS254		C505	CERAMIC CAPACITOR	CGCYX223K25
	D901-903	DIODE	1SS254		C509, 510	CERAMIC CAPACITOR	CKCYF103Z50
	D910-913	DIODE	1SS254		C513	ELECT. CAPACITOR	CEAS470M16
	D921	DIODE	1SS254		C514, 515	CERAMIC CAPACITOR	CKCYF103Z50

Mark	No.	Description	Part No.	Mark	No.	Description	Part No.
	C551	CERAMIC CAPACITOR	CGCYX823K25		R156	CARBONFILM RESISTOR	RD1/6PM□□□J
	C552	CERAMIC CAPACITOR	CGCYX223K25		R161-164	CARBONFILM RESISTOR	RD1/6PM□□□J
	C553	CERAMIC CAPACITOR	CGCYX472K25		R166	CARBONFILM RESISTOR	RD1/6PM□□□J
	C554	CERAMIC CAPACITOR	CGCYX103K25		R168	CARBONFILM RESISTOR (*2)	RD1/6PM□□□J
	C555	ELECT. CAPACITOR	CEAS010M50		R171, 172	CARBONFILM RESISTOR (*2)	RD1/6PM□□□J
	C701, 702	AXIAL CAPACITOR	CKPUYB101K50		R255-258	CARBONFILM RESISTOR	RD1/6PM□□□J
	C703, 704	ELECT. CAPACITOR	CEAS010M50		R260-266	CARBONFILM RESISTOR	RD1/6PM□□□J
	C705	ELECT. CAPACITOR	CEAS470M16		R276-278	CARBONFILM RESISTOR	RD1/6PM□□□J
	C706	CERAMIC CAPACITOR	CGCYF473Z50		R299	CARBONFILM RESISTOR	RD1/6PM□□□J
	C707, 708	ELECT. CAPACITOR	CEAS100M50		R307-314	CARBONFILM RESISTOR (*1)	RD1/6PM□□□J
	C711	ELECT. CAPACITOR	CEAS470M16		R321, 322		RCN1024
	C715, 716	ELECT. CAPACITOR	CEASR47M50		R323-328	CARBONFILM RESISTOR	RD1/6PM□□□J
	C717, 718	AUDIO FILM CAPACITOR	CFTXA822J50		R331	CARBONFILM RESISTOR (*1)	RD1/6PM□□□J
	C719, 720	AUDIO FILM CAPACITOR	CFTXA563J50		R332	CARBONFILM RESISTOR	RD1/6PM□□□J
	C721, 722	AUDIO FILM CAPACITOR	CFTXA823J50		R343, 344	CARBONFILM RESISTOR	RD1/6PM□□□J
	C723, 724	AXIAL CAPACITOR	CKPUYB101K50		R501	RESISTOR ARRAY (22K)	RA4T□□□J
	C762	AXIAL CAPACITOR	CKPUYB101K50		R504-509	CARBONFILM RESISTOR	RD1/6PM□□□J
	C763	ELECT. CAPACITOR	CEASR47M50		R510	RESISTOR ARRAY (*1)	RA5T□□□J
	C764	AXIAL CAPACITOR	CKPUYB271K50		R510	RESISTOR ARRAY (*2)	RA9T□□□J
	C765	ELECT. CAPACITOR	CEASR22M50		R512	RESISTOR ARRAY (68K)	RA6T□□□J
	C767, 768	CERAMIC CAPACITOR	CGCYX822K25		R514-517	CARBONFILM RESISTOR	RD1/6PM□□□J
	C769	CERAMIC CAPACITOR	CGCYF473Z50		R518	RESISTOR ARRAY	RA11T□□□J
	C801	AXIAL CAPACITOR	CKPUYB681K50		R520	CARBONFILM RESISTOR	RD1/6PM□□□J
	C851	AXIAL CAPACITOR	CKPUYB681K50		R524-529	CARBONFILM RESISTOR	RD1/6PM□□□J
	C910	CERAMIC CAPACITOR	CKCYF103Z50		R533	CARBONFILM RESISTOR (*2)	RD1/6PM□□□J
	C911	CERAMIC CAPACITOR	CGCYF473Z50		R534	CARBONFILM RESISTOR	RD1/6PM□□□J
	C913	ELECT. CAPACITOR	CEAS331M6R3		R551-561	CARBONFILM RESISTOR	RD1/6PM□□□J
	C914	ELECT. CAPACITOR	CEAS330M35		R563-565	CARBONFILM RESISTOR	RD1/6PM□□□J
	C915, 916	ELECT. CAPACITOR	CEAS100M50		R701-704	CARBONFILM RESISTOR	RD1/6PM□□□J
	C917, 918	ELECT. CAPACITOR	CEASR47M50		R707-730	CARBONFILM RESISTOR	RD1/6PM□□□J
	C919	CERAMIC CAPACITOR	CGCYF473Z50		R733-738	CARBONFILM RESISTOR	RD1/6PM□□□J
	C921	CERAMIC CAPACITOR	CGCYF473Z50		R741-744	CARBONFILM RESISTOR	RD1/6PM□□□J
	C1001	ELECT. CAPACITOR	CEAS221M50		R760-764	CARBONFILM RESISTOR	RD1/6PM□□□J
	C1004	ELECT. CAPACITOR	CEAS330M35		R766-768	CARBONFILM RESISTOR	RD1/6PM□□□J
	C1007	ELECT. CAPACITOR	CEAS472M16		R770-775	CARBONFILM RESISTOR	RD1/6PM□□□J
	C1008	CERAMIC CAPACITOR	CGCYF473Z50		R804		RCN053
	C1010	ELECT. CAPACITOR	CEAS102M10		R805	METALFILM RESISTOR	RN1/6PQ□□□□F
	C1011	ELECT. CAPACITOR	CEAS472M25		R806	CARBONFILM RESISTOR	RD1/6PM□□□J
	C1013	ELECT. CAPACITOR	CEAS331M16		R809, 810	CARBONFILM RESISTOR	RD1/6PM□□□J
	C1015	ELECT. CAPACITOR	CEAS331M16		R816	CARBONFILM RESISTOR	RD1/6PM□□□J
	C1016	ELECT. CAPACITOR	CEAS100M50		R818, 819	CARBONFILM RESISTOR	RD1/6PM□□□J
	C1018	ELECT. CAPACITOR	CEAS220M50		R854		RCN053
	C1020-1023	CERAMIC CAPACITOR	CGCYF473Z50		R855	METALFILM RESISTOR	RN1/6PQ□□□□F
	C1024	ELECT. CAPACITOR	CEAS470M16		R856	CARBONFILM RESISTOR	RD1/6PM□□□J
	C1030	CERAMIC CAPACITOR	CGCYF473Z50		R859-861	CARBONFILM RESISTOR	RD1/6PM□□□J
△	C1203	CAPACITOR (0.01/400)	RCG-009		R866	CARBONFILM RESISTOR	RD1/6PM□□□J
	C1606	CERAMIC CAPACITOR	CKCYF103Z50		R901	CARBONFILM RESISTOR	RD1/6PM□□□J
	C1607	CERAMIC CAPACITOR	CGCYF473Z50		R915-923	CARBONFILM RESISTOR	RD1/6PM□□□J
	C1701	CERAMIC CAPACITOR	CGCYF473Z50		R926, 927	CARBONFILM RESISTOR	RD1/6PM□□□J
					R941, 942	CARBONFILM RESISTOR	RD1/6PM□□□J
					R1001	CARBONFILM RESISTOR	RD1/2LF□□□J
					R1003, 1004	CARBONFILM RESISTOR	RD1/6PM□□□J
					R1007-1012	CARBONFILM RESISTOR	RD1/6PM□□□J
					R1014-1019	CARBONFILM RESISTOR	RD1/6PM□□□J
				△	R1020	FUSIBLE RESISTOR	RF4/4L□□□J
					R1101-1115	CARBONFILM RESISTOR(*1)	RD1/6PM□□□J

RESISTORS

R101-114	CARBONFILM RESISTOR	RD1/6PM□□□J
R117-120	CARBONFILM RESISTOR	RD1/6PM□□□J
R125, 126	CARBONFILM RESISTOR	RD1/6PM□□□J
R135, 136	CARBONFILM RESISTOR	RD1/6PM□□□J
R151-154	CARBONFILM RESISTOR	RD1/6PM□□□J

CT-W801R, CT-W701R

Mark	No.	Description	Part No.
	R1151-1165	CARBONFILM RESISTOR	RD1/6PM□□□J
	R1611	CARBONFILM RESISTOR	RD1/6PM□□□J
	R1701	RESISTOR ARRAY	RA5T□□□J
	R1702	LADDER RESISTOR	RCX1020
	R1703, 1704	CARBONFILM RESISTOR	RD1/6PM□□□J
	VR101-104	VR	RCP1046
	VR301, 302	VR (*1)	RCP1046
	VR321, 322	VR	RCP1045
	VR323, 324	VR (*2)	RCP1045
	VR551-553	VR	RCP1046
	VR802	VR	RCP1090
	VR851	VR	RCP1045
	VR852	VR	RCP1090

OTHERS

CN801	CONNECTOR (14P)	KPE14
CN851	CONNECTOR (14P)	KPE14
CN906	CONNECTOR	HLEM24S-1
CN3512		12JQ-BT
CN3522		12JQ-BT
CN4022		7JQ-BT
CN4032		7JQ-BT
JA701	JACK	RKB-020
JA902, 903	JACK	RKN1004
JA1602	JACK	RKN1005
X501	CERAMIC RESONATOR	VSS1014

HP, MIC UNIT (* 1) HP UNIT (+ 2)

SEMICONDUCTORS

IC1601	IC	BA15218N
IC2001	IC (*1)	BA15218N
Q1603, 1604	TRANSISTOR	2SD2144S

CAPACITORS

C1601, 1602	ELECT. CAPACITOR	CEASR22M50
C1603, 1604	ELECT. CAPACITOR	CEAS101M16
C1605	ELECT. CAPACITOR	CEAS331M16
C2001, 2002	AXIAL CAPACITOR (*1)	CKPUYB681K50
C2003, 2004	ELECT. CAPACITOR (*1)	CEAS010M50
C2005, 2006	ELECT. CAPACITOR (*1)	CEAS100M50
C2007, 2008	AXIAL CAPACITOR (*1)	CKPUYB101K50
C2009	ELECT. CAPACITOR (*1)	CEAS470M16
C2011, 2012	ELECT. CAPACITOR (*1)	CEAS010M50
C2017	CERAMIC CAPACITOR (*1)	CGCYF473Z50
C2020	CERAMIC CAPACITOR	CGCYF473Z50

RESISTORS

R1601-1606	CARBONFILM RESISTOR	RD1/6PM□□□J
R1609	METAL OXIDE RESISTOR	RS2LMF□□□J
R1612, 1613	CARBONFILM RESISTOR	RD1/6PM□□□J
R2001-2012	CARBONFILM RESISTOR(*1)	RD1/6PM□□□J
R2017, 2018	CARBONFILM RESISTOR(*1)	RD1/6PM□□□J
R2019, 2020	CARBONFILM RESISTOR	RD1/6PM□□□J

OTHERS

JA2001, 2002	JACK (*1)	RKN1003
JA2003	JACK	RKN1002

Mark	No.	Description	Part No.
------	-----	-------------	----------

OPERATE SW(1) UNIT

SWITCHES

S1301-1303	SWITCH	RSG1033
S1305, 1306	SWITCH	RSG1033

OPERATE SW(2) UNIT

SWITCHES

S1401-1403	SWITCH	RSG1033
S1405, 1406	SWITCH	RSG1033

DISPLAY UNIT

SEMICONDUCTORS

Q1501	DIGITAL TRANSISTOR	DTA114TS
D1501-1518	DIODE	ISS254

SWITCHES

S1501-1508	SWITCH	RSG1034
S1510-1516	SWITCH	RSG1034
S1517	SWITCH (*1)	RSG1034
S1518	SWITCH	RSG1034
S1520-1524	SWITCH	RSH1014

RESISTORS

R1501	CARBONFILM RESISTOR	RD1/6PM□□□J
R2015, 2016	CARBONFILM RESISTOR	RD1/6PM□□□J
VR2002	VARIABLE RESISTOR	RCV1086

OTHERS

CN907	CONNECTOR 24P	52492-2420
V1501		RAW1105

TR SEC UNIT

There is no supply part in this unit.

8. ADJUSTMENTS

8.1 MECHANICAL ADJUSTMENT

8.1.1 Door Damping Check and Adjustment

Set the door spring of DECK 1 side to position (A) as shown in Fig. 8-1. Then, erect the front panel assembly vertically.

Open the doors of DECK 1 and DECK 2 at the same time. At this point, confirm that the difference between opening degree of both doors is within 15mm when one side of the door is opened completely. When this standard is not satisfied, change the door spring installation position of Deck 1 and perform the adjustment as follows:

- When the opening action of the door of DECK 1 is later than that of DECK 2: Change the door spring of DECK 2 from A to B.
- When the opening action of the door of DECK 1 is faster than that of DECK 2: Change the door spring of DECK 1 from A to B.

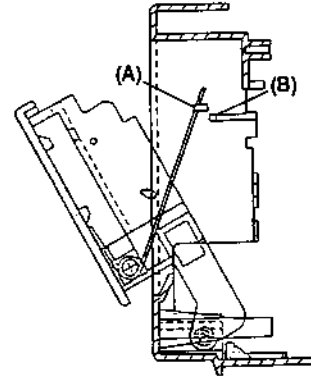

Fig. 8-1

8.1.2 Tape Speed

- Perform this adjustment in the test mode.
- TEST mode setting.
 1. Set the REV MODE to "≠".
 2. Short-circuit the JP901 and JP902 (TP14) for a moment. (Set into TEST mode.)
 3. The speed becomes normal when the PLAY key is pressed, and double when the FF key is pressed.
 4. To cancel the TEST mode, press the DECK I COUNTER RESET key or turn off the power.

1. Tape Speed Adjustment and Check						
No.	Deck	Mode	Test tape	Adjusting points	Specifications/Ratings (playback frequency)	Remarks
1	I	Double speed PLAY	STD-301 (3 kHz)	check	6000 Hz ± 600 Hz	
2	II			VR851	Within ± 10 Hz against the measurement value of the step 1 (deck I)	
3	I	Normal speed PLAY		VR802	3000 Hz ± 5 Hz	
4	II			VR852	Within ± 5 Hz against the measurement value of the step 3 (deck I)	

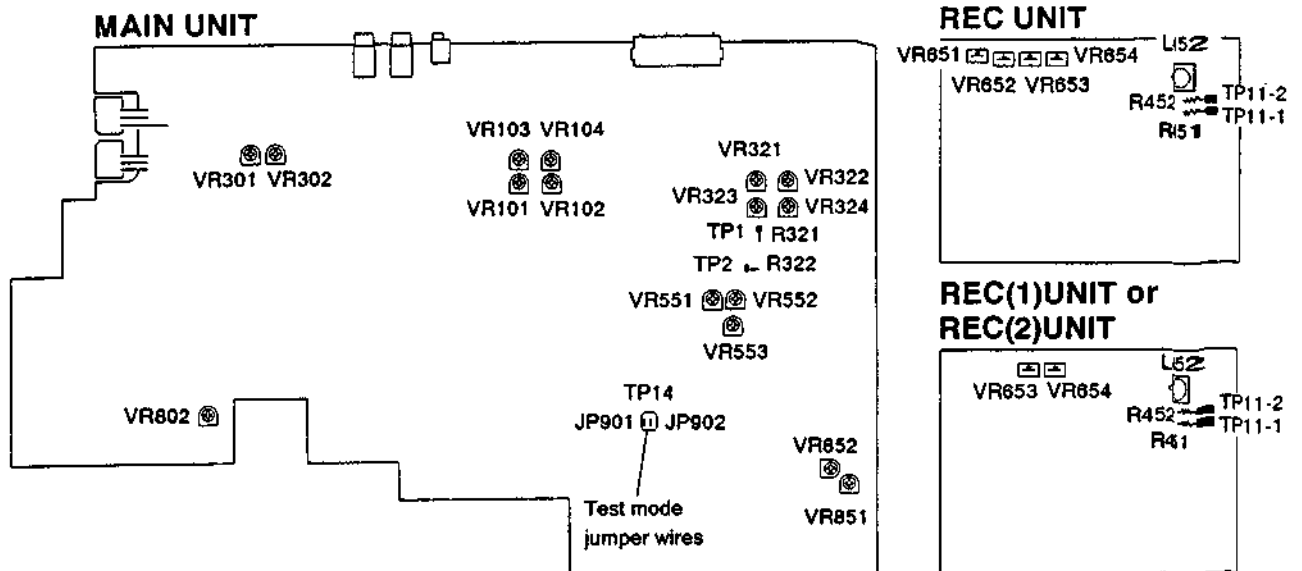

Fig. 8-2 Adjusting points

PLAYBACK SECTION

1. Head Azimuth Adjustment

- Turn VR103, 104 (Deck I) or VR101, 102 (Deck II) to mechanical center positions.

No.	Mode	Input signal & test tape	Adjustment location	Measuring location	Adjustment value	Remarks
1.	PLAY	Play the 10 kHz/-20 dB section of STD-331E test tape.	Head azimuth adjustment screw. (See Fig. 8-4)	LINE OUT	Maximum playback signal level.	
2.	STOP	Lock the screw with screw lock after completing adjustment.				

2. Playback Level Adjustment

- This adjustment determines the DOLBY NR level, and must be performed with great care.

No.	Mode	Input signal & test tape	Adjustment location	Measuring location	Adjustment value	Remarks
1.	PLAY	Play the 315 Hz/0 dB section of the STD-331E test tape.	Deck I VR 103 (Lch) VR 104 (Rch) Deck II VR 101 (Lch) VR 102 (Rch)	TP. 1 (Lch) TP. 2 (Rch)	-8.7 dBV	

RECORDING SECTION

1. Bias Oscillator Adjustment

- NOTE:** • Adjust CT-W701R with DECK II and check it with DECK I. If the results are unsatisfactory after checking DECK I, adjust DECK II so that the adjusting value becomes the lower limit. The value is satisfactory if it is 105 kHz \pm $\frac{1}{7}$ kHz.
• The specified value for the adjustments of CT-W801R, CT-W851R is 105 kHz \pm 0.3 kHz. If this specification cannot be obtained, values within 105 kHz \pm $\frac{1}{3}$ kHz are also satisfactory.

No.	Mode	Input signal & test tape	Adjustment location	Measuring location	Adjustment value	Remarks	
1.	REC	Load the STD-610 test tape with no input signal.	Deck I	L 452 *	TP. 11 - 1	105 kHz \pm $\frac{1}{7}$ kHz	CT-W701R
					TP. 11(DECK I SIDE REC UNIT)		CT-W801R, W851R
			Deck II	L 452 *	TP. 11 - 2	105 kHz \pm 0.3kHz	CT-W701R
					TP. 11(DECK II SIDE REC UNIT)		CT-W801R, W851R

- * For CT-W801R and CT-W851R, adjust L452 in the REC (1) UNIT of DECK I when adjusting this deck, and adjust L452 in the REC (2) UNIT of DECK II when adjusting this deck.

2. Recording Bias Adjustment

- After the adjustment, caution should be exercised so as not to become under bias by checking the distortion rate.

No.	Mode	Input signal & test tape	Adjustment location	Measuring location	Adjustment value	Remarks
1.	REC	Record the 315 Hz and 6.3 kHz signals at -26 dBV input level and playback. (STD-631)	Deck I VR651 (Lch) * 1 VR653 (Lch) * 2 VR652 (Rch) * 1 VR654 (Rch) * 2 Deck II VR653 (Lch) VR654 (Rch)	LINE OUT	Repeatedly record, playback and adjust so that the playback level of 6.3 kHz signal becomes 0 dB \pm 0.5 dB when compared with the 315 Hz signal.	

* 1: CT-W701R only

* 2: CT-W801R, W851R only; Adjust VR653, VR654 of DECK I with the REC (1) UNIT of DECK I, and adjust those of DECK II with the REC (2) UNIT of DECK II

CT-W801R, CT-W851R, CT-W701R

3. Recording Level Adjustment

No.	Mode	Input signal & test tape	Adjustment location	Measuring location	Adjustment value	Remarks
1.	REC PAUSE	Apply a 315 Hz/0 dBV signal to the line input terminals, load the STD-631 test tape.	REC level control volume	TP. 1 (Lch) TP. 2 (Rch)	-11.2 dBV	
2.	STOP	Set the DOLBY NR switch to the ON position. (DOLBY B)				
3.	REC/PLAY	Record the above signal onto the STD-631 test tape, and playback.	Deck I	VR321 (Lch) * 1 VR301 (Lch) * 2 VR322 (Rch) * 1 VR302 (Rch) * 2	TP. 1 (Lch) TP. 2 (Rch)	Repeatedly record, playback and adjust so that the playback signal level becomes -11.2 dBV.
			Deck II	VR323 (Lch) * 1 VR321 (Lch) * 2 VR324 (Rch) * 1 VR322 (Rch) * 2		
4.	REC/PLAY	Record the above signal onto the STD-621 test tape, and playback.	Check	TP. 1 (Lch) TP. 2 (Rch)	-11.2 dBV ± 1.5dB	
5.	REC/PLAY	Record the above signal onto the STD-610 test tape, and playback.				

- * 1: CT-W701R only
- * 2: CT-W801R, W851R only

4. Level Meter Check

No.	Mode	Input signal & test tape	Adjustment location	Measuring location	Adjustment value	Remarks
1.	REC PAUSE	Apply a 315 Hz/-10 dBV (318 mV) signal to the Line Input terminals.	REC level control volume	TP. 1 (Lch) TP. 2 (Rch)	Check that the level meters "0 dB" light up within -7.2 dBV ± 2 dB of the signal output level.	

5. SUPER AUTO BLE Adjustment

- BLE adjustment should be performed after all other adjustments are completed.
- This adjustment should be performed in the test mode.
- Entering the test mode.

For details of how to enter the test mode, refer to the "Mechanical Adjustment" section (Page 31).

No.	Mode	Input signal & test tape	Adjustment location	Measuring location	Adjustment value	Remarks
1.		Set to test mode.	-	-	-	
2.		Press the NORMAL SPEED key on the front panel.	Level meter	VR551	Adjust so that -1 dB on the level meter turn on and off.	400 Hz adjustment
3.		Press the HIGH SPEED key on the front panel.		VR553		10 kHz adjustment
4.		Press the BLE key (DECK II SIDE) on the front panel.		VR552		3 kHz adjustment

Reference: The output of LINE OUT after completing the adjustments for 400 Hz, 10 kHz, 3 kHz becomes -28 dBV ± 1dB.

8. REGLAGES

8.1 REGLAGE MÉCANIQUE

8.1.1 Contrôle et Réglage de l'Amortisseur de Trappe

Placer le ressort de trappe du côté de la platine 1 sur la position (A) comme indiqué dans la Fig. 8-1. Redresser ensuite l'ensemble de panneau avant verticalement.

Ouvrir les trappes de la platine 1 et de la platine 2 en même temps. A ce point, s'assurer que la différence entre le degré d'ouverture des deux trappes est de moins de 15mm lorsqu'un côté de la trappe est complètement ouvert. Lorsque cette valeur est différente de la valeur standard mentionnée, changer la position de mise en place du ressort de trappe de la platine 1 et effectuer un réglage comme suit:

- Lorsque l'action d'ouverture de la trappe de la platine 1 se fait plus lentement que celle de la platine 2: Changer le ressort de la trappe de la platine 2 de A à B.

- Lorsque l'action d'ouverture de la trappe de la platine 1 se fait plus rapidement que celle de la platine 2: Changer le ressort de la trappe de la platine 1 de A à B.

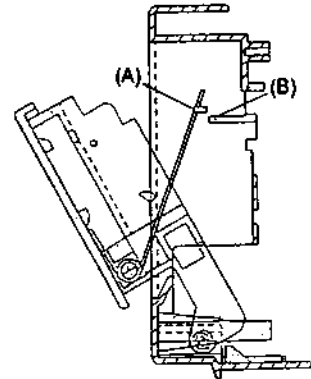

Fig. 8-1

8.1.2 Vitesse de défilement de la bande

- Régler au mode TEST.
 - Réglage du mode TEST.
1. Régler le sélecteur REV MODE à "↔".
 2. Court-circuiter JP901 et JP902 (TP14) un moment. (Régler au mode TEST.)
 3. La vitesse devient normale à la pression de la touche PLAY, et double à la pression de la touche FF.
 4. appuyer sur la touche DECK I COUNTER RESET ou mettre hors tension pour annuler le mode TEST.

1. Réglage et contrôle de la vitesse de défilement de la bande						
No.	Platine	Mode	Bande testée	Points de réglage	Spécifications/valeurs nominales (fréquence de lecture)	Remarques
1	I	PLAY double vitesse	STD-301 (3 kHz)	contrôl	6000 Hz ± 600 Hz	
2	II			VR851	Moins de ± 10 Hz par rapport à la valeur mesurée à l'étape 1 (platine I)	
3	I	PLAY vitesse normale		VR802	3000 Hz ± 5 Hz	
4	II			VR852	Moins de ± 5 Hz par rapport à la valeur mesurée à l'étape 3 (platine I)	

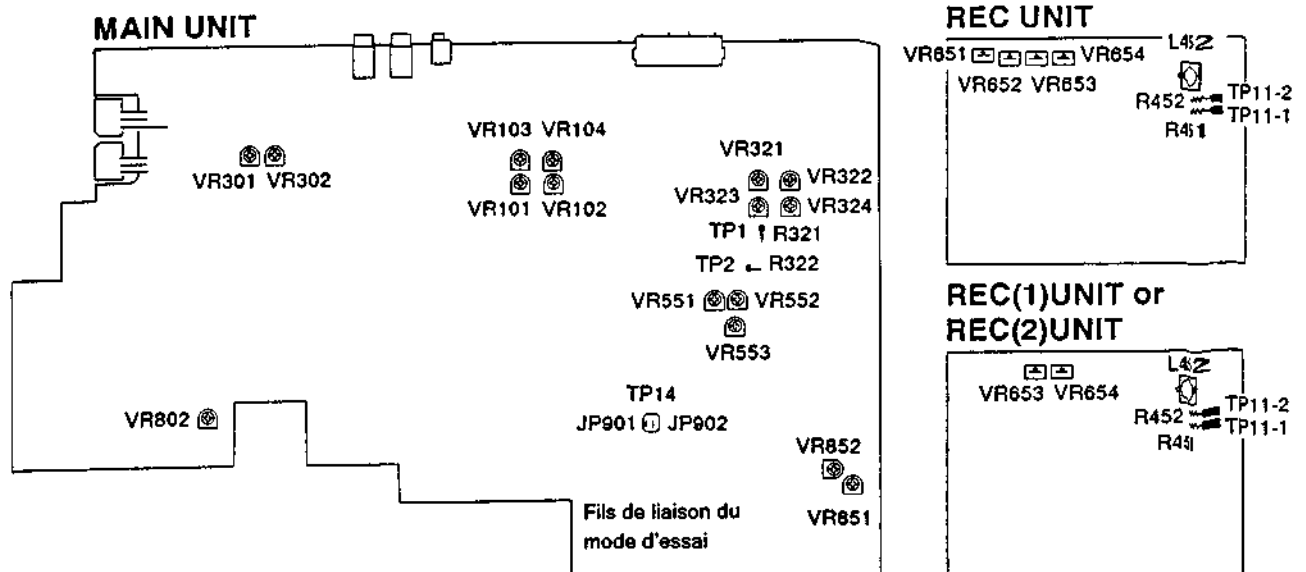

Fig. 8-2 Points réglage

8.2 REGLAGES ELECTRIQUES

Conditions de réglage

1. Les réglages mécaniques doivent tout d'abord être terminés.
2. Les têtes doivent être nettoyées et démagnétisées.
3. Mettre la platine sous tension et la laisser chauffer pendant au moins quelques minutes avant de commencer les réglages électriques.
4. Le signal de référence est de 0 dBV=1 Vrms.
5. Connecter une résistance de charge de 50 k Ω (tolérance 47k à 52 k Ω) aux bornes de sortie (OUTPUT).
6. Sauf indication contraire, les commutateurs ci-dessous doivent être laissés sur les positions indiquées.
 DOLBY NR : OFF
 Sélecteur de bande : NORM
 (TAPE SELECTOR)

Bandes d'essai

- STD-331E : Réglages de la lecture
 (Voir fig. 8-3)
- STD-631 : Bande vierge de type normal
- STD-621 : Bande vierge de type chrome
- STD-610 : Bande vierge de type métal

* Le niveau d'enregistrement de référence étant de 250 nwb/m pour le STD-331E, le niveau d'enregistrement sera supérieur de 4 dB pour le STD-331B (160 nwb/m). Pour le réglage, tenir compte du type de bande utilisé.

Liste des réglages

Sections de lecture

1. Réglage de l'azimut de la tête.
2. Réglage du niveau de lecture.

Sections d'enregistrement

1. Réglage de l'oscillateur de polarisation.
2. Réglage de la polarisation d'enregistrement.
3. Réglage du niveau d'enregistrement.
4. Vérification de l'indicateur de niveau.
5. Réglage de SUPER AUTO B.L.E.

REMARQUE:

Cette unité est dotée d'une sélection automatique de bande.

Réduction de bruit Dolby et HX Pro headroom extension fabriqués sous licence de Dolby Laboratories Licensing Corporation. HX Pro est d'origine Bang & Olufsen. DOLBY, le symbole double-D $\square\square$ et HX PRO sont des marques de Dolby Laboratories Licensing Corporation.

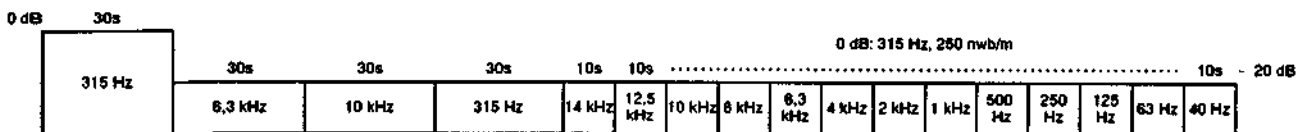

Fig. 8-3 Constantes de la bande d'essai STD-331E

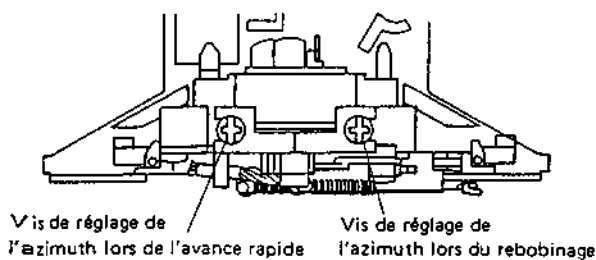
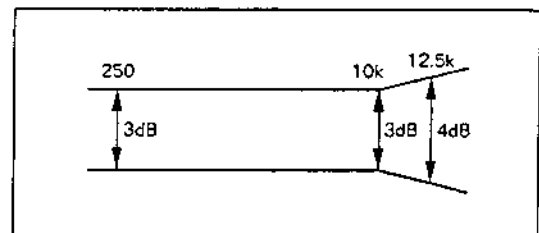

Fig. 8-4 Réglage de l'azimut de la tête

LECTURE



ENREGISTREMENT

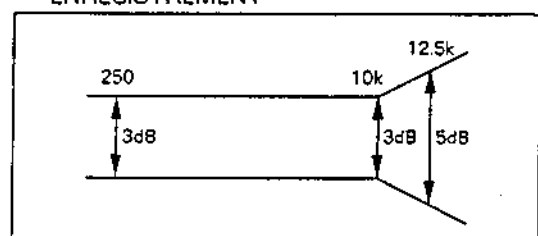

Fig. 8-5 Zone de réponse en fréquence

SECTION DE LECTURE

1. Réglage de l'azimut de la tête

- Tourner VR 103, 104 (Platine I) ou VR 101, 102 (Platine II) sur leur position centrale mécanique.

No.	Mode	Signal d'entrée et bande d'essai	Points de réglage	Points de mesure	Valeur de réglage	Remarques
1.	PLAY	Reproduire la section 10 kHz/-20 dB de la bande d'essai STD-331E.	Vis de réglage de l'azimut de la tête. (Voir fig. 8-4)	Sortie de ligne (LINE OUT)	Niveau du signal de reproduction maximum.	
2.	STOP	Verrouiller la vis avec le verrouillage de vis après avoir terminé le réglage.				

2. Réglage du niveau de lecture

- Ce réglage détermine le niveau DOLBY NR et il doit être effectué très soigneusement.

No.	Mode	Signal d'entrée et bande d'essai	Points de réglage	Points de mesure	Valeur de réglage	Remarques
1.	PLAY	Reproduire la section 315 Hz/0 dB de la bande d'essai STD-331E.	Platine I VR103 (can. G) VR104 (can. D) Platine II VR101 (can. G) VR102 (can. D)	TP. 1 (can. G) TP. 2 (can. D)	-6.7 dBV	

SECTION D'ENREGISTREMENT

1. Réglage de l'oscillateur de polarisation

- NOTE: • Régler CT-W701R avec DECK II et le contrôler avec DECK I. Si le résultat n'est pas satisfaisant après le contrôle de DECK I, régler DECK II de sorte que la valeur réglée soit celle de la limite inférieure. Une valeur entre $105 \text{ kHz} \pm \frac{4}{7} \text{ kHz}$ est satisfaisante.
- La valeur de réglage spécifiée pour les CT-W801R et CT-W851R est $105 \text{ kHz} \pm 0.3 \text{ kHz}$. Si elle ne peut pas être obtenue, des valeurs de $105 \text{ kHz} \pm \frac{4}{0.3} \text{ kHz}$ sont aussi acceptables.

No.	Mode	Signal d'entrée et bande d'essai	Points de réglage	Points de mesure	Valeur de réglage	Remarques	
1.	REC	Charger la bande d'essai STD-610 et n'introduire aucun signal.	Platine I	L 452*	TP. 11 - 1	$105 \text{ kHz} \pm \frac{4}{7} \text{ kHz}$	CT-W701R
				TP. 11(DECK I SIDE REC UNIT)	CT-W801R, W851R		
			Platine II	L 452*	TP. 11 - 2	$105 \text{ kHz} \pm 0.3 \text{ kHz}$	CT-W701R
					TP. 11(DECK II SIDE REC UNIT)		CT-W801R, W851R

- * Pour CT-W801R et CT-W851R, régler L452 dans le REC (1) UNIT de DECK I en réglant cette platine, et régler L452 dans REC (2) UNIT de DECK II en réglant cette platine.

2. Réglage de la polarisation d'enregistrement

- Après le réglage, des précautions doivent être prises pour éviter une sous-polarisation en vérifiant le taux de distorsion.

No.	Mode	Signal d'entrée et bande d'essai	Points de réglage	Points de mesure	Valeur de réglage	Remarques
1.	STOP	Enregistrer les signaux 315 Hz et 6,3 kHz à un niveau d'entrée de -20 dBV et les reproduire. (STD - 631)	Platine I VR851 (can. G) * 1 VR853 (can. G) * 2 VR852 (can. D) * 1 VR854 (can. D) * 2 Platine II VR853 (can. G) VR854 (can. D)	Sortie de ligne (LINE OUT)	Enregistrer, reproduire et régler de manière répétée de sorte que le niveau de lecture du signal 6,3 kHz devienne $0 \text{ dB} \pm 0.5 \text{ dB}$ lorsqu'il est comparé avec le signal 315 Hz.	

* 1: CT-W701R seulement

* 2: CT-W801R, W851R seulement: Régler VR853, VR854 de DECK I avec REC (1) UNIT de DECK I, puis ceux de DECK II avec REC (2) UNIT de DECK II.

3. Réglage du niveau d'enregistrement

No.	Mode	Signal d'entrée et bande d'essai	Points de réglage	Points de mesure	Valeur de réglage	Remarques
1.	REC PAUSE	Appliquer un signal de 315 Hz/0 dBV aux bornes d'entrée de ligne, charger la bande d'essai STD-831.	Volume de la commande de niveau d'enregistrement.	TP. 1 (can. G) TP. 2 (can. D)	-11.2 dBV	
2.	STOP	Régler le commutateur DOLBY NR sur la position ON. (DOLBY B)				
3.	REC/PLAY	Enregistrer le signal cidessus sur la bande d'essai STD-831 et le reproduire.	Platine I	TP. 1 (can. G) TP. 2 (can. D)	Enregistrer, reproduire et régler de manière répétée de sorte que le niveau du signal devienne - 11.2 dBV.	
			Platine II			
4.	REC/PLAY	Enregistrer le signal cidessus sur la bande d'essai STD-821 et le reproduire.	Vérifier	TP. 1 (can. G) TP. 2 (can. D)	-11.2 dBV ± 1.5 dB	
5.	REC/PLAY	Enregistrer le signal cidessus sur la bande d'essai STD-810 et le reproduire.				

* 1: CT-W701R seulement
* 2: CT-W801R, W851R seulement

4. Vérification de l'indicateur de niveau

No.	Mode	Signal d'entrée et bande d'essai	Points de réglage	Points de mesure	Valeur de réglage	Remarques
1.	REC PAUSE	Appliquer un signal de 315 Hz/-10 dBV (316 mV) aux bornes d'entrée de ligne.	Volume de la commande de niveau d'enregistrement	TP. 1 (can. G) TP. 2 (can. D)	Vérifier que les indicateurs de niveau "0 dB" s'allument dans la limite de -7.2 dBV ± 2 dB du niveau de sortie du signal.	

5. Réglage de SUPER AUTO BLE

- Le réglage BLE doit être effectué après que tous les autres réglages sont complétés.
 - Ce réglage doit être effectué dans le mode d'essai.
 - Passage au mode d'essai.
- Pour les détails du passage en mode d'essai, voir la section "Réglages mécaniques" (Page 38).

No.	Mode	Signal d'entrée et bande d'essai	Points de réglage	Points de mesure	Valeur de réglage	Remarques
1.		Régler dans le mode d'essai.	-	-	-	
2.		Appuyer sur la touche NORMAL SPEED du panneau avant.	L'indicateur de niveau	VR551	Régler de sorte que - 1 dB sur l'indicateur de niveau s'allume et s'éteigne.	Réglage 400 Hz
3.	Appuyer sur la touche HIGH SPEED du panneau avant.	VR553		Réglage 10 kHz		
4.	Appuyer sur la touche BLE(DECK II SIDE) du panneau avant.	VR552		Réglage 3 kHz		

Référence: Après l'achèvement des réglages pour 400 Hz, 10 kHz et 3 kHz, la sortie de LINE OUT devient - 20 dBV ± 1 dB.

8. AJUSTES

8.1 AJUSTE MECANICO

8.1.1 Comprobación y ajuste de la amortiguación de la puerta

Ajuste el resorte de la puerta del DECK 1 en la posición (A) como se muestra en la Fig. 8-1. Luego, levante el conjunto del panel frontal en forma vertical. Abra las puertas de los DECK 1 y DECK 2 al mismo tiempo.

Entonces, confirme que la diferencia entre el grado de abertura de ambas puertas sea de 15mm como máximo cuando se abre por completo un lado de la puerta. Cuando no se satisfacen estas medidas, cambie la posición de instalación del resorte de la puerta del DECK 1 y efectúe el ajuste del modo siguiente:

- Cuando la acción de abrir la puerta del DECK 1 es más retardada que la del DECK 2: Cambie el resorte de la puerta del DECK 2 de A a B.

- Cuando la acción de abrir la puerta del DECK 1 es más rápida que la del DECK 2: Cambie el resorte de la puerta del DECK 1 de A a B.



Figura. 8-1

8.1.2 Velocidad de la Cinta

- Realice este ajuste en el modo de prueba.
- Ajuste del modo TEST.

1. Ajuste el REV MODE en "±".
2. Cortocircuite JP901 y JP902 (TP14) durante un momento.(Ajuste en el modo TEST.)
3. La velocidad es normal cuando se oprime la tecla PLAY, y doble cuando se oprime la tecla FF.
4. Para cancelar el modo TEST, oprima la tecla DECK I COUNTER RESET o desconecte la alimentación.

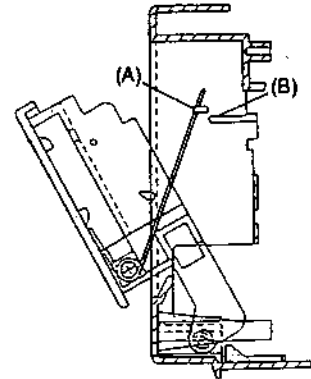
1. Ajuste y Verificación de la Velocidad de la Cinta						
N.º	Unidad	Modo	Cinta de prueba	Puntos de ajuste	Especificaciones/Valores nominales (frecuencia de reproducción)	Observaciones
1	I	PLAY a velocidad doble	STD-301 (3 kHz)	Verificar	6000 Hz ± 600 Hz	
2	II			VR851	Dentro de ± 10 Hz contra el valor de medición del paso 1 (unidad I)	
3	I	PLAY a velocidad normal		VR802	3000 Hz ± 5 Hz	
4	II			VR852	Dentro de ± 5 Hz contra el valor de medición del paso 3 (unidad I)	



Figura. 8-2 Puntos de ajuste

8.2 AJUSTES ELÉCTRICOS

Condiciones de ajuste

1. Los ajustes mecánicos deben haberse completado primero.
2. La cabeza debe estar limpia y desmagnetizada.
3. Encienda la alimentación para permitir que la platina se caliente durante unos pocos minutos por lo menos antes de realizar cualquier ajuste eléctrico.
4. La señal de referencia es de 0 dBV=1 Vrms.
5. Conecte una resistencia de 50 kΩ (o entre 47k y 52 kΩ) en los terminales OUTPUT.
6. A menos que se especifique lo contrario, los conmutadores indicados más abajo deben dejarse en las posiciones indicadas.

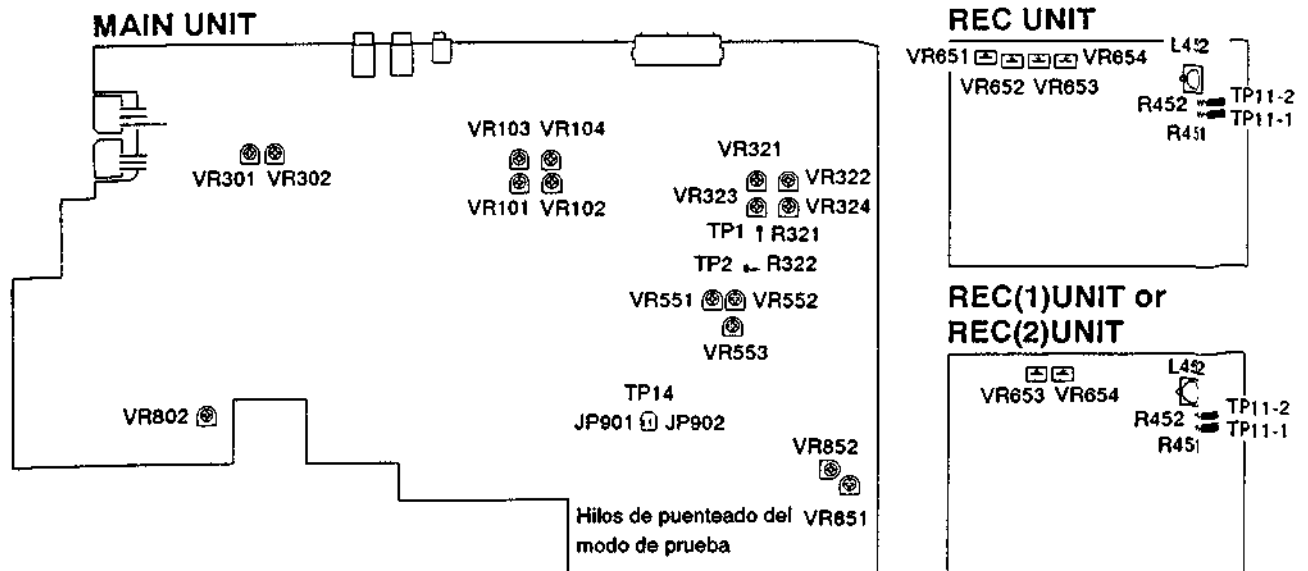
DOLBY NR : OFF
 TAPE SELECTOR : NORM

Cintas de prueba

- STD-331E : Ajustes de reproducción
 (Consulte la figura 8-3)
- STD-631 : Cinta virgen NORMAL
- STD-621 : Cinta virgen de CrO2
- STD-610 : Cinta virgen de METAL

* Como el nivel de grabación de referencia es igual a 250 nwb/m para el STD-331E, el nivel de grabación será 4 dB mayor para el STD-331B (160 nwb/m). Al realizar el ajuste, preste suma atención al tipo de cinta que se está utilizando.

Lista de ajustes

Secciones de reproducción

1. Ajuste de azimut de la cabeza
2. Ajuste del nivel de reproducción

Secciones de grabación

1. Ajuste del oscilador de polarización
2. Ajuste de la polarización de grabación
3. Ajuste del nivel de grabación
4. Verificación del medidor de nivel
5. Ajuste SUPER AUTO BLE

NOTA:
 Esta unidad posee una función de selección automática de cinta.

Reduccion de ruido Dolby y HX Pro headroom extension fabricados bajo licencia de Dolby Laboratories Licensing Corporation. HX Pro producido por Bang & Olufsen. DOLBY, el simbolo de la D doble  y HX PRO son marcas de Dolby Laboratories Licensing Corporation.



Figura 8-3 Constantes de la cinta de prueba STD-331E



Figura 8-4 Ajuste de azimut de la cabeza

REPRODUCCIÓN

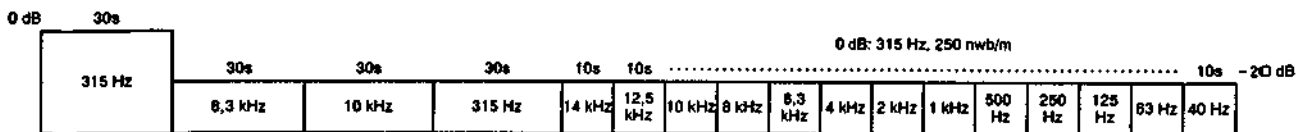

GRABACIÓN

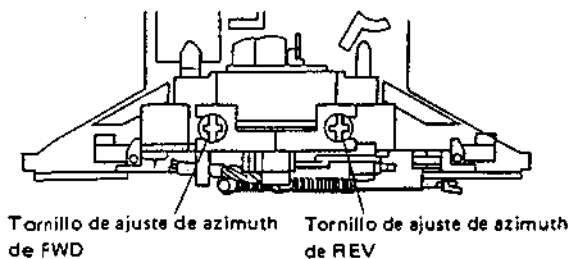
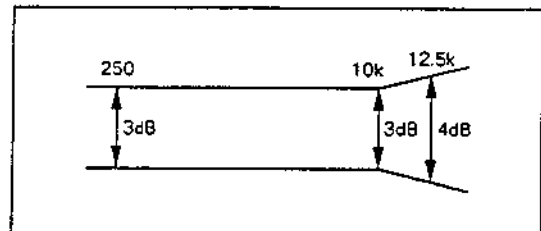

Figura 8-5 Zona de respuesta de frecuencia

SECCIÓN DE REPRODUCCIÓN

1. Ajuste del azimut de la cabeza

- Poner VR103, 104 (platina I) o VR101, 102 (platina II) en las posiciones del centro mecánico.

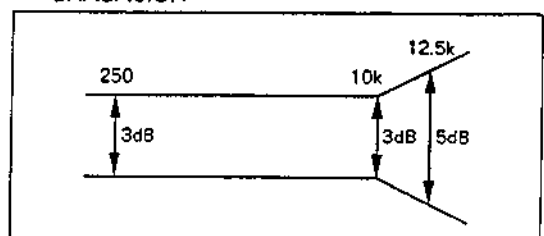
N.º	Modo	Señal de entrada y cinta de prueba	Punto de ajuste	Punto de medición	Valor de ajuste	Comentarios
1.	PLAY	Reproduzca la sección de 10 kHz/-20 dB de la cinta de prueba STD-331E.	Tomillo de ajuste del azimut de la cabeza. (Vea la figura 8-4)	LINE OUT	Nivel máximo de la señal de reproducción.	
2.	STOP	Bloquee el tornillo con su cierre una vez finalizado el ajuste.				

2. Ajuste del nivel de reproducción

- Este ajuste determina el nivel DOLBY NR y debe realizarse con mucho cuidado.

N.º	Modo	Señal de entrada y cinta de prueba	Punto de ajuste	Punto de medición	Valor de ajuste	Comentarios	
1.	PLAY	Produzca la parte de 315 Hz/0 dB de la cinta de prueba STD-331E.	Platina I	VR103 (Lch) VR104 (Rch)	TP. 1 (Lch) TP. 2 (Rch)	-6.7 dBV	
			Platina II	VR101 (Lch) VR102 (Rch)			

SECCIÓN DE GRABACIÓN

1. Ajuste del oscilador de polarización

- Nota: • Ajuste el CT-W701R con el DECK II y verifíquelo con el DECK I. Si después de verificar el DECK I los resultados no son satisfactorios, ajuste el DECK II en forma tal que el valor de ajuste sea igual al límite inferior. El valor es satisfactorio si es igual a $105 \text{ kHz} \pm \frac{4}{7} \text{ kHz}$.
- El valor especificado para los ajustes de CT-W801R, CT-W851R es $105 \text{ kHz} \pm 0.3 \text{ kHz}$. Si no fuera posible obtener esta especificación, valores comprendidos entre $105 \text{ kHz} \pm 0.3 \text{ kHz}$ son también satisfactorios.

N.º	Modo	Señal de entrada y cinta de prueba	Punto de ajuste	Punto de medición	Valor de ajuste	Comentarios		
1.	REC	Introduzca la cinta de prueba STD-610 sin señal de entrada.	Platina I	L 452*	TP. 11 - 1	$105 \text{ kHz} \pm \frac{4}{7} \text{ kHz}$	CT-W701R	
				TP. 11(DECK I SIDE REC UNIT)	CT-W801R, W851R			
			Platina II	L 452*	TP. 11 - 2		$105 \text{ kHz} \pm 0.3 \text{ kHz}$	CT-W701R
					TP. 11(DECK II SIDE REC UNIT)			CT-W801R, W851R

Para el CT-W801R y el CT-W851R, ajuste L452 en la REC (1) UNIT del DECK I cuando ajuste este magnetófono, y ajuste L452 en la REC (2) UNIT del DECK II cuando ajuste este magnetófono.

2. Ajuste de polarización de grabación

- Una vez finalizado el ajuste, compruebe el porcentaje de distorsión para no obtener subpolarización.

N.º	Modo	Señal de entrada y cinta de prueba	Punto de ajuste	Punto de medición	Valor de ajuste	Comentarios
1.	REC	Grabe la señal de 315 Hz y 6.3 kHz a un nivel de entrada de -26 dBV y reproduzcala. (STD - 631)	Platina I	LINE OUT		Grabe, reproduzca y ajuste repetidamente para que el nivel de la señal de reproducción de 6.3 kHz sea de $0 \text{ dB} \pm 0.5 \text{ dB}$ cuando se compare con la señal de 315 Hz.
			VR651 (Lch) * 1 VR653 (Lch) * 2			
			VR652 (Rch) * 1 VR654 (Rch) * 2			
			Platina II	VR653 (Lch) VR654 (Lch)		

*1: CT-W701R solamente

*2: CT-W801R, W851R solamente: Ajuste VR653, VR654 del DECK I con la REC (1) UNIT del DECK I, y ajuste los del DECK II con la REC (2) UNIT del DECK II.

3. Ajuste del nivel de grabación

N.º	Modo	Señal de entrada y cinta de prueba	Punto de ajuste	Punto de medición	Valor de ajuste	Comentarios
1.	REC PAUSE	Aplique una señal de 315 Hz/0 dBV a los terminales de entrada de línea e introduzca la cinta de prueba STD-831.	Control de nivel de grabación.	TP. 1 (Lch) TP. 2 (Rch)	-11.2 dBV	
2.	STOP	Ponga el conmutador DOLBY NR en la posición ON. (DOLBY B)				
3.	REC/PLAY	Grabe la señal de arriba en la cinta de prueba STD-831 y reproduzca.	Platina I	VR321 (Lch) * 1 VR301 (Lch) * 2	TP. 1 (Lch) TP. 2 (Rch)	Grabe, reproduzca y ajuste repetidamente para que el nivel de la señal de reproducción sea de - 11.2 dBV.
			Platina II	VR323 (Lch) * 1 VR321 (Lch) * 2		
4.	REC/PLAY	Grabe la señal de arriba en la cinta de prueba STD-821 y reproduzca.	Verifique		-11.2 dBV ± 1.5dB	
5.	REC/PLAY	Grabe la señal de arriba en la cinta de prueba STD-810 y reproduzca.				

- * 1: CT-W701R solamente
- * 2: CT-W801R, W851R solamente

4. Verificación del medidor de nivel

N.º	Modo	Señal de entrada y cinta de prueba	Punto de ajuste	Punto de medición	Valor de ajuste	Comentarios
1.	REC PAUSE	Aplique una señal de 315 Hz/-10 dBV (316 mV) a los terminales de entrada de línea.	Control de nivel de grabación	TP. 1 (Lch) TP. 2 (Rch)	Verifique si se encienden los medidores de nivel "0 dB" cuando el nivel de salida de la señal sea -7.2 dBV ± 2 dB.	

5. Ajuste SUPER AUTO BLE

- El ajuste BLE debe efectuarse después de haber terminado todos los otros ajustes.
 - Este ajuste debe efectuarse en el modo de prueba.
 - Cómo establecer el modo de prueba.
- Con respecto a los detalles de cómo se entra en el modo de prueba, consulte la sección "Ajuste Mecánico" (Página 41).

N.º	Modo	Señal de entrada y cinta de prueba	Punto de ajuste	Punto de medición	Valor de ajuste	Comentarios
1.		Establezca el modo de prueba.	-	-	-	
2.		Pulse la tecla NORMAL SPEED del panel delantero.	En medidor de nivel	VR551	Ajuste de modo tal que - 1dB se active y desactive en el medidor de nivel.	Ajuste de 400 Hz
3.	Pulse la tecla HIGH SPEED del panel delantero.	VR553		Ajuste de 10 kHz		
4.	Pulse la tecla BLE (DECK II SIDE) del panel delantero.	VR552		Ajuste de 3 kHz		

Referencia: Después de completar los ajustes para 400 Hz, 10 kHz y 3 kHz, la salida de LINE OUT es igual a - 26 dBV ± 1 dB.

9. IC DESCRIPTIONS

• The information shown in the list is basic information and may not correspond exactly to that shown in the schematic diagrams.

9.1 PD4381A (IC501)

● Block diagram

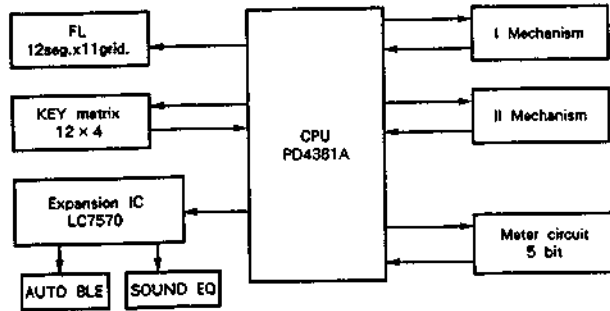

● Pin arrangement

1	S3	VCSY	34
2	S2	S4	35
3	S1	S5	36
4	S0	S6	37
5	SENSE1	S7	38
6	SENSE2	S8	39
7	SONG	S9	40
8	VER.	Urw	41
9	POFF	Vload	42
10	REMOCON	S10	43
11	METER - L	S11	44
12	METER - R	BLEON	45
13	WR	1RMUTE	46
14	CLK	2RMUTE	47
15	DATA	T10	48
16	BLK	T9	49
17	1CRO	T8	50
18	1MET	T7	51
19	2CRO	T6	52
20	2MET	T5	53
21	KEY0	T4	54
22	KEY1	T3	55
23	KEY2	T2	56
24	KEY3	T1	57
25	1X1	T0	58
26	LINE MUTE	RESET	59
27	1CPM	2SOL	60
28	1SOL	2CPM	61
29	OSC	DECODE	62
30	OSC1	2X1	63
31	OSC2	XT2	64
32	GND	XT1	65

● Terminal descriptions

Pin No.	Name	I/O	Descriptions	Pin No.	Name	I/O	Descriptions
1	S3	O	Segment output, key scan output, level scan output terminal	16	BLK	O	Output stop output terminal for expansion IC
2	S2	O	Segment output, key scan output, level scan output terminal	17	1CRO	I	1 mechanism CrO2 detection input terminal "L"-SW ON
3	S1	O	Segment output, key scan output, level scan output terminal	18	1MET	I	1 mechanism METAL detection input terminal "L"-SW ON
4	S0	O	Segment output, key scan output, level scan output terminal	19	2CRO	I	2 mechanism CrO2 detection input terminal "L"-SW ON
5	SENSE1	I	1 mechanism sensing pulse input terminal	20	2MET	I	2 mechanism METAL detection input terminal "L"-SW ON
6	SENSE2	I	2 mechanism sensing pulse input terminal	21	KEY0	I	Input terminal for key scan
7	SONG	I	SONG input terminal "H"-SONG exists.	22	KEY1	I	Input terminal for key scan
8	VER.	I	VER. switching terminal	23	KEY2	I	Input terminal for key scan
9	POFF	I	POWER OFF input terminal "H" active	24	KEY3	I	Input terminal for key scan
10	REMOCON	I	Remote commander input terminal	25	1X1	O	1 mechanism normal speed/double speed switching output terminal "L"-SW ON
11	METER - L	I	Input terminal for Lch level detection	26	LINE MUTE	O	Line mute output terminal "L"-SW ON
12	METER - R	I	Input terminal for Rch level detection	27	1CPM	O	1 mechanism capstan motor driving terminal "H"-ON
13	WR	O	Output timing output terminal for expansion IC	28	1SOL	O	1 mechanism solenoid driving terminal "H"-ON
14	CLK	O	Clock output terminal for expansion IC	29	OSC	O	400/10 kHz square wave output terminal for AUTO BLE
15	DATA	O	Data output terminal for expansion IC	30	OSC1	-	Crystal/ceramic connecting terminal for main system clock oscillation

CT-W801R, CT-W851R, CT-W701R

Pin No.	Name	I/O	Function	Pin No.	Name	I/O	Function
31	OSC2	-	Crystal/ceramic connecting terminal for main system clock oscillation	48	T8	O	Grid output terminal for FL display
32	GND	--	GND	49	T9	O	Grid output terminal for FL display
33	XT1	I	Crystal connecting terminal for sub-system clock oscillation (Not used)	50	T10	O	Grid output terminal for FL display
34	XT2	-	Crystal connecting terminal for sub-system clock oscillation (Not used)	51	2RMUTE	O	2 mechanism REC mute output terminal "H"=ON
35	2 × 1	O	2 mechanism normal speed/double speed switching output terminal "L"=Double speed	52	1RMUTE	O	1 mechanism REC mute output terminal "H"=ON
36	DECODE	O	Decode/encode output terminal "H"=DECODE, "L"=ENCODE	53	BLEON	O	AUTO BLE ON output terminal On at BLE
37	2CPM	O	2 mechanism capstan motor driving terminal "H"=ON	54	S11	O	Segment output, key scan output terminal
38	2SOL	O	2 mechanism solenoid driving terminal "H"=ON	55	S10	O	Segment output, key scan output terminal
39	RESET	I	System reset input terminal "L" active	56	VLOAD	-	Pull-down resistor connecting terminal for FL controller/driver (Not used)
40	T0	O	Grid output terminal for FL display	57	VPRE	-	Power supply terminal for FL controller/driver output buffer
41	T1	O	Grid output terminal for FL display	58	S9	O	Segment output, key scan output terminal
42	T2	O	Grid output terminal for FL display	59	S8	O	Segment output, key scan output terminal
43	T3	O	Grid output terminal for FL display	60	S7	O	Segment output, key scan output terminal
44	T4	O	Grid output terminal for FL display	61	S6	O	Segment output, key scan output terminal
45	T5	O	Grid output terminal for FL display	62	S5	O	Segment output, key scan output terminal
46	T6	O	Grid output terminal for FL display	63	S4	O	Segment output, key scan output, level scan output terminal
47	T7	O	Grid output terminal for FL display	64	VC5V	-	+5V power supply terminal

9.2 LC7570 (IC510)

● Port arrangement

42	41	40	39	38	37	36	35	34	33	32	31	30	29	28	27	26	25	24	23	22
LEVEL20	LEVEL21	LEVEL22	LEVEL23	EQ20	EQ21	EQ22	EQ23	BIAS20	BIAS21	(Not used) BIAS22	(Not used) BIAS23	(CRO2) LEVEL10	(METAL) LEVEL11	(Not used) LEVEL12	(Not used) LEVEL13	(RECSEL 1) EQ10	(RECSEL 2) EQ11	(Not used) EQ12	(Not used) EQ13	FADE
GND	WR	CLK	DATA	VC5V	BLK	GND	SIN	2PB	HI	2BIAS	1BIAS	FSEL1	FSEL0	DOL1	DOL2	TOCD	REFAST	GEQ2	GEQ1	GEQ0
1	2	3	4	5	6	7	8	9	10	11	12	13	14	15	16	17	18	19	20	21

The () contains the pin names for CT-W701R.

● Terminal descriptions

Pin No.	Name	Descriptions	Pin No.	Name	Descriptions
1	GND	Pull-down resistor COMMON terminal	24	EQ12	Output terminal bit 2 for 1 mechanism AUTO BLE EQ correction (CT-W701R is not used)
2	WR	Output timing input terminal	25	EQ11	Output terminal bit 1 for 1 mechanism AUTO BLE EQ correction (CT-W801R, W851R)
3	CLK	Clock input terminal		RECSEL2	REC mode 2 mechanism select output terminal (CT-W701R)
4	DATA	Data input terminal	26	EQ10	Output terminal bit 0 for 1 mechanism AUTO BLE EQ correction (CT-W801R, W851R)
5	VC5V	+5V power supply terminal		RECSEL1	REC mode 1 mechanism select output terminal (CT-W701R)
6	BLK	Output stop input terminal	27	LEVEL13	Output terminal bit 3 for 1 mechanism AUTO BLE LEVEL correction (CT-W701R is not used)
7	GND	GND	28	LEVEL12	Output terminal bit 2 for 1 mechanism AUTO BLE LEVEL correction (CT-W701R is not used)
8	SIN	Not used	29	LEVEL11	Output terminal bit 1 for 1 mechanism AUTO BLE LEVEL correction (CT-W801R, W851R)
9	2PB	REC/PB head switching output terminal "H" during playing back 2 mechanism		METAL	Recording system METAL auto tape select output terminal (CT-W701R)
10	HI	Playback equalizer switching output terminal "L" at HI position	30	LEVEL10	Output terminal bit 0 for 1 mechanism AUTO BLE LEVEL correction (CT-W801R, W851R)
11	2BIAS	Output terminal for 2 mechanism BIAS oscillation		CRO2	Recording system CRO2 auto tape select output terminal (CT-W701R)
12	1BIAS	Output terminal for 1 mechanism BIAS oscillation	31	BIAS11	Output terminal bit 1 for 1 mechanism AUTO BLE BIAS correction (CT-W701R is not used)
13	FSEL1	Frequency switching output terminal 1 for AUTO BLE	32	BIAS10	Output terminal bit 0 for 1 mechanism AUTO BLE BIAS correction (CT-W701R is not used)
14	FSEL0	Frequency switching output terminal 0 for AUTO BLE	33	BIAS21	Output terminal bit 1 for 2 mechanism AUTO BLE BIAS correction
15	DOL1	Dolby switching output terminal 1	34	BIAS20	Output terminal bit 0 for 2 mechanism AUTO BLE BIAS correction
16	DOL2	Dolby switching output terminal 2	35	EQ23	Output terminal bit 3 for 2 mechanism AUTO BLE EQ correction
17	TOCD	CD control signal output terminal	36	EQ22	Output terminal bit 2 for 2 mechanism AUTO BLE EQ correction
18	REFAST	Constant switching output terminal at meter amplifier FAST="H", SLOW="L"	37	EQ21	Output terminal bit 1 for 2 mechanism AUTO BLE EQ correction
19	GEQ2	Surround EQ output terminal 2	38	EQ20	Output terminal bit 0 for 2 mechanism AUTO BLE EQ correction
20	GEQ1	Surround EQ output terminal 1	39	LEVEL23	Output terminal bit 3 for 2 mechanism AUTO BLE LEVEL correction
21	GEQ0	Surround EQ output terminal 0	40	LEVEL22	Output terminal bit 2 for 2 mechanism AUTO BLE LEVEL correction
22	FADE	Fade out output terminal	41	LEVEL21	Output terminal bit 1 for 2 mechanism AUTO BLE LEVEL correction
23	EQ13	Output terminal bit 3 for 1 mechanism AUTO BLE EQ correction (CT-W701R is not used)	42	LEVEL20	Output terminal bit 0 for 2 mechanism AUTO BLE LEVEL correction

9.3 Power On Initializing

1. CPU Reset

When the power is turned on, the RESET terminal (Pin 39) of the CPU synchronizes with the rising of the CPU 5V. The reset is released, and processing starts from the head of the program. As each CPU port goes into the "high impedance" condition during the time from power on to reset release, it is necessary to set to "H" or "L" with external parts.

(a) Port Initializing

Sets the amplifier system port into the "non-active" condition.

(b) Mechanism Initializing

The initializing of the mechanism is performed as shown in the following figure in the order of 1 mechanism → 2 mechanism by setting both mechanisms into the "STOP" condition.

As the amplifier system circuit is unstable immediately after the power is turned on, key inputs (including the remote control unit) will not be accepted for about 4 seconds.

If the mechanism does not return to the "STOP" condition, it is determined as "error", and mechanism initializing is performed once again. If "error" occurs the second time, mechanism operations are stopped and "emergency" is set.

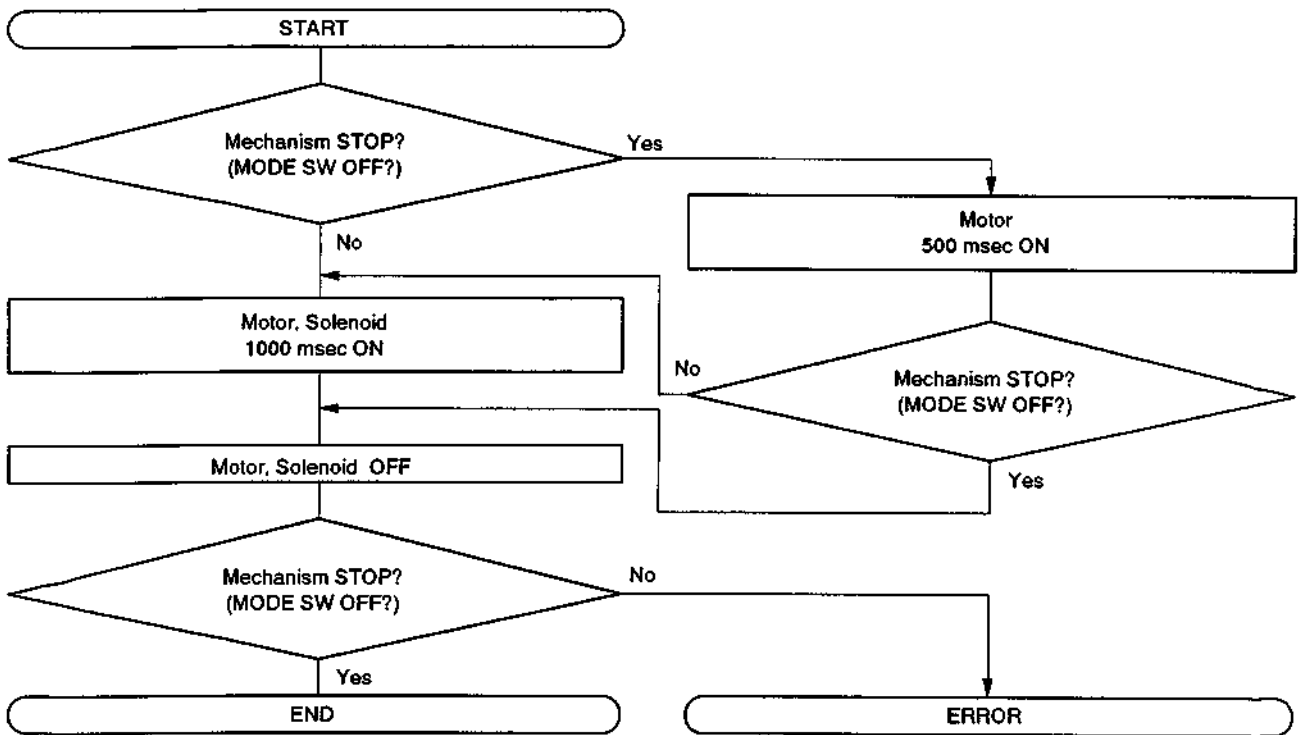

9.4 Amplifier System Control

FUNCTION	DECK1	DECK2	LINE MUTE	1REC MUTE	1BIAS	2REC MUTE	2BIAS	DECODE	× 1
	STOP	STOP OR FAST	L	H	L	H	L	L	H
	PLAY		H	H	L	H	L	H	H
	PPAUSE		L	H	L	H	L	H	H
	FAST		L	H	L	H	L	L	H
	MS		L	H	L	H	L	H	H
	REC		H	L	H	H	L	L	H
	RPAUSE		H	H	L	H	L	L	H
	RMUTE		H	H	H	H	L	L	H
	STOP OR FAST	STOP	L	H	L	H	L	L	H
		PLAY	H	H	L	H	L	H	H
		PPAUSE	L	H	L	H	L	H	H
		FAST	L	H	L	H	L	L	H
		MS	L	H	L	H	L	H	H
		REC	H	H	L	L	H	L	H
		RPAUSE	H	H	L	H	L	L	H
		RMUTE	H	H	L	H	H	L	H
× 1COPY	REC	PLAY	H	H	L	L	H	H	H
	RPAUSE		H	H	L	H	L	H	H
	RMUTE		H	H	L	H	H	H	H
× 2PLAY	× 2PLAY	× 2REC	H	H	L	L	H	H	L
PARA REC	REC	REC	H	L	H	L	H	L	H
	RPAUSE	RPAUSE	L	H	L	H	L	L	H
	RMUTE	RMUTE	H	H	H	H	H	L	H

CT-W801R, CT-W851R, CT-W701R

9.5 Automatic Tape Select Function

1. Playback EQ Switching

Performs the playback EQ 70 μ sec/120 μ sec switching for both sides I and II.

2. Input

Takes the SW information of the mechanism into the input port direct. Performs only types II and IV inputs for both sides I and II (CRO of CPU, MET terminal. SW ON at "L") to discriminate the TYPE of the tape.

3. Mechanism mode and input SW

I Mechanism Mode	II Mechanism Mode	Playback System	Recording System
STOP, FAST	STOP, FAST	Side II SW	Side II SW
PLAY, PPAUSE, MS	STOP, FAST	Side I SW	Side II SW
REC, RPAUSE, RMUTE	STOP, FAST	Side II SW	Side I SW
STOP, FAST	PLAY, PPAUSE, MS	Side II SW	Side II SW
STOP, FAST	REC, RPAUSE, RMUTE	Side II SW	Side II SW
PLAY	REC, RPAUSE, RMUTE	Side I SW	Side II SW

4. Output

		TYPE I (NOR)	TYPE II (CrO ₂)	TYPE IV (METAL)
Playback System	FI	H	L	L
Recording System	CRO2	L	H	H
	METAL	L	L	H

9.6 Relay Dolby Function

1. Relay Dolby

Controls by using two dolby slide SWs exclusive for sides I and II for each dolby IC.

2. SW Input

Takes in the respective SW conditions of sides I and II with the key matrix.

3. Mechanism Mode, Dolby Display and Real Dolby Input SW

I Mechanism Mode	II Mechanism Mode	Side I Display	Side II Display	DOLBY IC
STOP, FAST	STOP, FAST	Side I SW	Side II SW	Side II SW
PLAY, PPAUSE, MS	STOP, FAST	Side I SW	Side II SW	Side I SW
REC, RPAUSE, RMUTE	STOP, FAST	Side I SW	Side II SW	Side I SW
STOP, FAST	PLAY, PPAUSE, MS	Side I SW	Side II SW	Side II SW
STOP, FAST	REC, RPAUSE, RMUTE	Side I SW	Side II SW	Side II SW
PLAY	REC, RPAUSE, RMUTE	Side I SW	Side I SW	Side I SW
REC, RPAUSE, RMUTE	REC, RPAUSE, RMUTE	Side I SW	Side I SW	Side I SW

For models without this relay dolby function, the SW of side II is always taken in to select the dolby type.

5. Output

	DOL0	DOL1
Dolby OFF	H	L
Dolby B	L	H
Dolby C	L	L

6. Mechanism Mode and Dolby Mute Control

	Dolby Switching	
	LINE MUTE	REC MUTE
STOP		
FF, REW		
PLAY	ON	
PPAUSE		
MS		
REC	OFF	ON
RPAUSE	OFF	
RMUTE	OFF	
X1COPY	ON	OFF
X2COPY	ON	OFF
PARA REC	OFF	ON

The "ON" in the table indicates the 150 msec forcible ON. MUTE processing is not performed during OFF.

9.7 AUTO BLE Function

The AUTO BLE function corrects any random tape so that the recording playback frequency characteristics become flat.

1. Differences according to Models

① CT-W801R, CT-W851R (TWIN AUTO BLE, 3 point BLE)

Both sides I and II have its own correction circuit. The BLE data is output from the respective exclusive BLE output ports.

② CT-W701R (RELAY AUTO BLE, 3 point BLE)

The heads of sides I and II are tuned by switching the SWs at the correction circuit shared by both sides I and II. After tuning, the BLE data of both sides I and II are recorded by the CPU. The BLE data of the recording side is output from the BLE output port shared by sides I and II.

2. Accepted Conditions

- When the side performing AUTO BLE is "REC possible".
- When the side performing AUTO BLE is in the STOP mode, and other sides are STOP, FF, or REW.

3. Operations

- The AUTO BLE operations can be started by pressing the AUTO BLE key when the two conditions above are present.
- When the AUTO BLE is started, both the LINE MUTE terminal ("L" output) and BLEON terminal (Pin 53) turn on. When the BLEON terminal turns on, the line input becomes muted, DOLBY turns off, and the MPX filter turns on.
- After forwarding the tape for 1 second with FF (leader path), perform the following settings.
- After completing the following settings, rewind to the BLE start point with REW, and stop.

(a) Bias Setting

Change the bias current in the three stages; REF, -10% and +10%. Record and playback the 400 Hz and 10 kHz signals at the respective bias values. Select the bias value at which the playback level difference is the minimum. Next, check that the 400 Hz playback level at this bias value is not greatly different from the level which is to be taken as the reference. If it is, re-select the bias value at which the level becomes closest to the reference level.

(b) Level Setting

Record and playback the 400 Hz signal while sweeping it in the 16 stage steps (\pm approximately 3 dB range. LEVEL DATA=0 to 15. REF. DATA is 8.), and set so that the playback level becomes closest to the level to be taken as the reference.

(c) EQ Setting

Record the 10 kHz signal while sweeping it in the 8 stage steps (\pm approximately 3 dB range. EQ DATA=0 to 7. REF. DATA is 5 for the NORMAL, CrO₂ TAPE, and 3 for the METAL TAPE.) Finally, record the 3 kHz with the reference EQ. Next, set so that the playback level becomes close to the level to be taken as the

reference. If the 3 kHz playback level is lower than the level to be taken as the reference by more than 0.5 dB, perform mid-range correction (raise the mid-range level), and take the slack of the f characteristics in the vicinity of 3 kHz.

(d) Check points

Check points have been provided to prevent incorrect adjustments during AUTO BLE operations. Errors are determined when the various check points cannot be passed. When errors have been determined, the mechanism is stopped, BIAS, LEVEL and EQ are returned to their reference values, and the "ERR" blinking display is shown. This display continues until the normal display is returned by pressing a certain key.

• STOP check

Error is determined when the mechanism stops due to tape end. (When BLE is set, forcible STOP is set with tape end.)

• Blank check

Perform the 500 msec blank recording immediately before recording the test signal. Return to the center of this blank when rewinding. If it is blank at the start of playback, the tape is determined as being at its correct position. "Error" is determined if it is not blank.

• Recording signal rising check

The rising of the playback signal is most important for BLE. The signal is determined according to the time from this rising. The signal must rise within 500 msec from blank check at the latest. If this cannot be confirmed within this period, it is determined as "error".

• Leader tape check

Check if the tape is in the leader tape section by checking if the playback signal is present or absent immediately after EQ setting. Error is determined if there is no signal in the leader tape.

(e) Mask PLAY and Blank REC

In the mechanism, as the tape running also does not become stable immediately after PLAY mode assist has been completed, some time will be required for running stabilization. This time is 1.5 seconds. At the start of BIAS recording, at least 0.5 to 2 seconds are required for blank REC. The 1.5 seconds mask play is also performed before starting each check PLAY.

(f) Rewinding

For the BLE of conventional mechanisms, rewinding was performed by REW (FF) because the tape position could be determined with the tape counter. However, for the BLE of this unit, this method cannot be used as the tape counter lags very easily. The tape is therefore rewound using PLAY which has very little lagging. The rewinding amount is controlled by time. However, the tape may advance more than required in some cases when the assist for this side cannot be performed because of the assists of other mechanisms due to stagger processing. This time during which the tape was advanced is measured, and the tape is advanced in the reverse direction for this time during the next PLAY operation. This enables an almost precise start position searching to be performed.

CT-W801R, CT-W851R, CT-W701R

(g) RELAY AUTO BLE

This will be relayed to side II after those for side I have been completed by pressing the AUTO BLE key of side I in the RELAY MODE ON, if BLE has not been adjusted for both sides I and II. The RELAY mode is released when adjustments for side II start.

(h) Test Signal Frequency Switching

The test signal frequency switching is controlled in the following way using two FSEL0 and FSEL1 port outputs.

Frequency	FSEL0	FSEL1
400Hz	H	H
3kHz	L	H
10kHz	H	L

For 2 POINT BLE, the 3 kHz control will not be performed.

(i) BLE related Port Output and BLE Data

	BIAS*1	BIAS*0	DATA
- 10%	L	H	1
REF	H	L	2
+ 10%	L	L	0

400Hz	LEVEL*3	LEVEL*2	LEVEL*1	LEVEL*0	DATA
MIN	H	H	H	H	F
REF	H	L	L	H	8
MAX	L	L	L	L	0

10kHz	EQ*2	EQ*1	EQ*0	DATA 1
MIN	H	H	H	7
REF	H (L)	L (H)	H (H)	5 (3)
MAX	L	L	L	0

3kHz	EQ*3	DATA
UP	L	DATA1
REF	H	DATA1 + 8

Side I becomes 1 and side II becomes 2 for *.

() indicates that for the metal tape.

The respective BLE DATAs of sides I and II can be checked on the counter for any mode by pressing the 2-PAUSE +1-FWD +2-FWD key simultaneously.

(j) AUTO BLE Time Chart

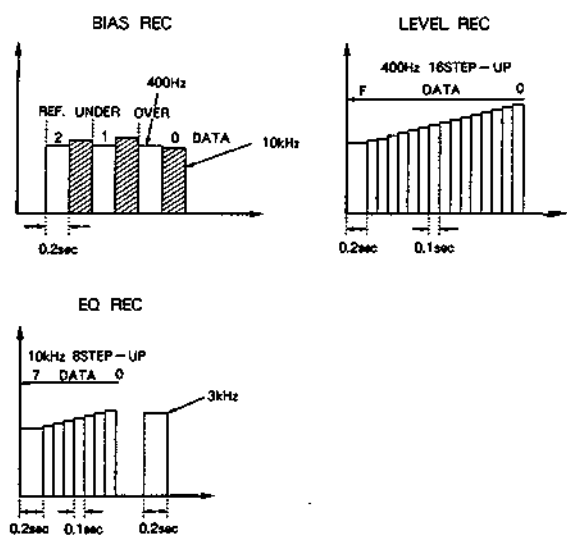
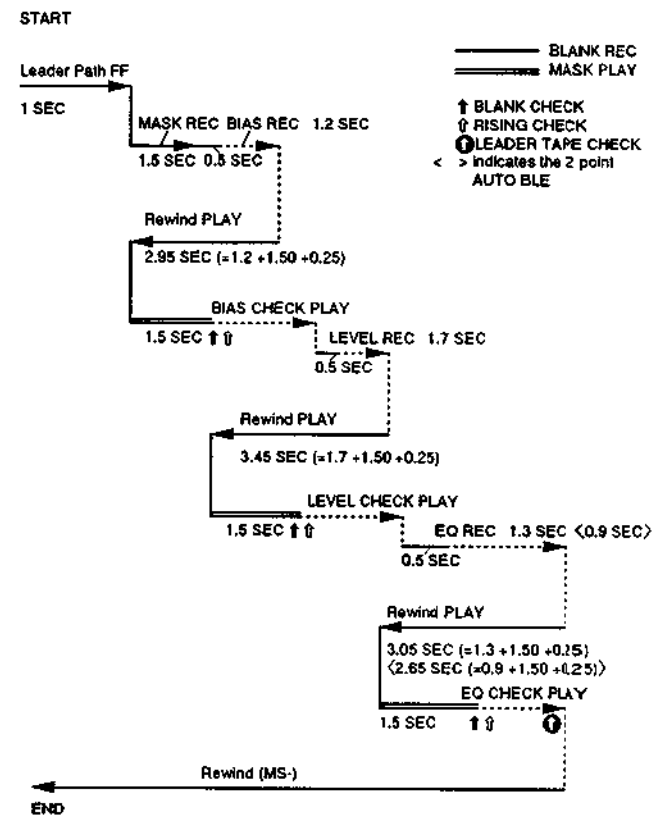

3kHz is not recorded and played back for 2 POINT BLE.

9.8 Sound EQ Function

Function which equalizes the input signal with a frequency characteristic variable circuit being provided at the line input. There are two positions; CAR for car stereos and PORTABLE for headphone stereos. These can be switched using the slide SWs.

• Accepted conditions

Modes which operate basically during recording only (CPU constantly checks the condition of the SW, and outputs to the port.)

1. Output

The CPU controls in the following way using the 3 bits; GEQ0, GEQ1 and GEQ2.

Output Port	CAR	OFF	PORTABLE
GEQ0	L	L	H
GEQ1	H	L	H
GEQ2	H	L	H

2. Display

Displays in the following way using the counter and meter when the slide SW has been switched.

① Counter display

Displays "PORT" on side I and "ABLE" on side II for PORTABLE, and displays "CAR" on both sides for CAR one word at a time at an interval of 80 msec twice.

"P" → "PO" → "POR" → "PORT" → "PORTA" → "PORTAB" → "PORTABL" → "PORTABLE" → Repeated once more.

② Meter Display

Synchronizes the frequency characteristic corrected by the sound EQ with the character of the counter display using the meter in a pseudo way, and displays every segment one at a time at an interval of 80 msec twice. The following will be displayed when the meters have all lighted up.

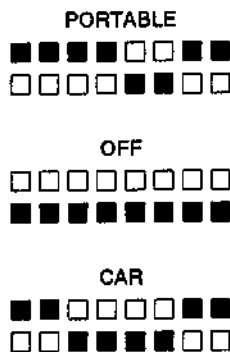

3. Mechanism Mode, Mute Control and Display

	Sound EQ Switching		
	LINE MUTE	REC MUTE	Display
STOP			○
FF, REW			○
PLAY			×
PPAUSE			×
MS			×
REC	ON	ON	○
RPAUSE	ON		○
RMUTE	ON		○
X1COPY			×
X2COPY			×
PARA REC	ON	ON	○

The "ON" in the table indicates the 150 msec forcible ON.

○.....Display ON

×.....Display OFF

9.9 CD Synchro Function

The CD synchro function sets the deck into the REC condition and the CD player into the PLAY condition, and performs tape copy from the CD with the one touch input of the CD SYNCRO key on the deck side when the PIONEER CD player is connected with a 2.5 φ monaural jack (2 wires) (Common GND with AUDIO jack).

1. Accepted Conditions

- Connected to the PIONEER CD player (corresponding to CD SYNCRO function) with the 2.5 φ monaural jack, and shares the GND with the AUDIO jack.
- A REC possible tape is inserted in either side I or II, or both sides I and II.
- When both sides I and II are in the STOP mode or only one side is in the FF, REW modes.

2. Operations

- Operates with the input of the CD SYNCRO key when all three conditions above are present. At this time, the REC possible side (Side I when both sides are REC possible) starts REC with the CD SYNCRO key rising edge input (press the key). Following, the CD starts PLAY with the CD SYNCRO key falling edge input (Press the key), and the deck copies from the CD. Therefore, while the CD SYNCRO key is being pressed, a blank is created on the tape.
- During the CD SYNCRO COPY mode, the REC side only accepts the STOP key and the STOP mode is set. The opposite side of the side recording accepts the FF, REW and STOP keys and starts operating.

CT-W801R, CT-W851R, CT-W701R

- In the case of tape end, the CD player searches for the head of the song which had been interrupted first, and then sets into the PLAY/PAUSE mode. (PLAY BACK PAUSE). Although the end processing is performed according to the reverse mode, when the tape becomes reversed, the CD player will not played but made to wait at PLAY/PAUSE for 10 seconds after REC has been set to let the leader section to pass by.
- If side II is in the FF or REW mode when relaying from side I to side II, the relay will not be performed.
- When the relay mode is on, relay from side I to II is performed when the CD player performs the first disc changing. (When side II can be relayed)
- When more than one minute has passed after both sides have stopped, the CD player which has been set into the PLAY BACK PAUSE mode will stop (fail-safe). If a tape is re-inserted during this time and the CD SYNCHRO key is pressed, the CD SYNCHRO COPY can be continued.
- In the case of disc end (when disc is not changed), the deck is set into REC/PAUSE and then stops after 1 minute (fail-safe). However, the CD SYNCHRO COPY can be continued once again by pressing the PLAY key of the CD player during this time.
- For disc changes during CD SYNCHRO COPY with a multi or twin CD player, the deck sets into REC/PAUSE during disc changing. The CD SYNCHRO COPY continues once again after the changing completes and the CD player becomes PLAY.
- The deck side has been adjusted so that the blank time created on the tape during tape end and disc change is 4 to 5 seconds.

3. The receiving and transmission format of the control signal between the deck and CD player during the CD SYNCHRO mode is as follows.

- When the deck commands the CD player

CD Player Mode	TOCD
PLAY	"L" EDGE
PLAY BACK PAUSE	"H" EDGE

- When the CD player commands the deck

Deck Mode	FROM CD
REC/PAUSE	"H" EDGE
REC (PAUSE released)	"L" EDGE

- When the deck informs the CD player of the current mode

Deck Mode	TO CD
REC	"L" STATE
REC/PAUSE	"H" STATE
Other than above	"H" STATE

- When the CD player informs the deck of the current mode

CD Player Mode	FROM CD
PLAY, SEARCH	"L" STATE
PLAY BACK PAUSE	"L" STATE
Other than above	"H" STATE

Note)The "H" and "L" in the table indicate the "active" after the outputs of the two CPU ports have been inverted via the buffer (Active received by the two CPU input ports).

9.10 Display Function
PD4381A Indicator Lighting Mode

I. I FWD II FWD



		I				II				COPY	HI SPEED
		REV	FWD	PLAY	REC	REV	FWD	PLAY	REC		
I FWD	STOP		▶								
	FF		▶								
	REW	▶	▶								
	MS +		▶	☉							
	MS -	▶	▶	☉							
	PLAY		▶	○							
	PPAUSE		▶	○							
	REC		▶		●						
	RPAUSE		▶		●						
	RMUTE		▶		●						
II FWD	STOP						▶				
	FF						▶				
	REW					▶	▶				
	MS +						▶	☉			
	MS -					▶	▶	☉			
	PLAY						▶	○			
	PPAUSE						▶	○			
	REC						▶		●		
	RPAUSE						▶		●		
	RMUTE						▶		●		
× 1 COPY			▶	○			▶		●	□	
× 2 COPY			▶	○			▶		●	□	□

Those displayed with ☉ indicate a 160 msec blinking.
 Those displayed with ▶ indicate a 320 msec blinking.
 Others are lit.

CT-W801R, CT-W851R, CT-W701R

2. I REV II REV

		I				II				COPY	HI SPEED
		REV	FWD	PLAY	REC	REV	FWD	PLAY	REC		
I FWD	STOP	◀									
	FF	▶	▶								
	REW	◀									
	MS +	▶		☀							
	MS -	◀	▶	☀							
	PLAY	▶		○							
	PPAUSE	◀-▶		○							
	REC	▶			●						
	RPAUSE	◀-▶			●						
	RMUTE	▶			◌						
II FWD	STOP					▶					
	FF					▶	▶				
	REW					▶					
	MS +					▶		☀			
	MS -					▶	▶	☀			
	PLAY					▶		○			
	PPAUSE					◀-▶		○			
	REC					▶			●		
	RPAUSE					◀-▶			●		
	RMUTE					▶			◌		
X1 COPY		▶		○		▶			●	◻	
X2 COPY		▶		○		▶			●	◻	◻

Those displayed with  indicate a 160 msec blinking.
 Those displayed with  indicate a 320 msec blinking.
 Others are lit.

3. I FWD II REV



		I				II				COPY	HI SPEED
		REV	FWD	PLAY	REC	REV	FWD	PLAY	REC		
I FWD	STOP		▶								
	FF		▶								
	REW	◀	▶								
	MS +		▶	☀							
	MS -	◀	▶	☀							
	PLAY		▶	○							
	PPAUSE		▶	○							
	REC		▶		●						
	RPAUSE		▶		●						
	RMUTE		▶		◻						
II FWD	STOP					▶					
	FF					▶	▶				
	REW					◀					
	MS +					◀		☀			
	MS -					▶	▶	☀			
	PLAY					▶		○			
	PPAUSE					▶		○			
	REC					▶			●		
	RPAUSE					▶			●		
	RMUTE					▶			◻		
X1 COPY			▶	○		▶			●	◻	
X2 COPY			▶	○		▶			●	◻	◻

Those displayed with ☀ indicate a 160 msec blinking.
 Those displayed with ▶ indicate a 320 msec blinking.
 Others are lit.

CT-W801R, CT-W851R, CT-W701R

4. I REV II FWD

		I				II				COPY	HI SPEED
		REV	FWD	PLAY	REC	REV	FWD	PLAY	REC		
I FWD	STOP	◀									
	FF	◀	▶								
	REW	▶									
	MS +	▶		☀							
	MS -	◀	▶	☀							
	PLAY	◀		○							
	PPAUSE	◀-◀		○							
	REC	◀			●						
	RPAUSE	◀-◀			●						
	RMUTE	◀			●-●						
II FWD	STOP					▶					
	FF					▶					
	REW				▶	▶					
	MS +					▶	☀				
	MS -				▶	▶	☀				
	PLAY					▶	○				
	PPAUSE					▶-▶	○				
	REC					▶		●			
	RPAUSE					▶-▶		●			
	RMUTE					▶		●-●			
X1 COPY	◀		○		▶		●	□			
X2 COPY	◀		○		▶		●	□	□		

Those displayed with  indicate a 160 msec blinking.
 Those displayed with  indicate a 320 msec blinking.
 Others are lit.

9.11 Test Mode

MODE NO.	Display	Input key	LINE MUTE	2REC MUTE	2 BIAS	1REC MUTE	1 BIAS	Adjustment and Check Contents
0	0	STOP	ON	ON	OFF	ON	OFF	
1	1	RELAY/ SKIP	ON	ON	OFF	ON	OFF	<p>◇ SW check</p> <ul style="list-style-type: none"> • When there is no "half", the respective counters will display "HALF". • Incorrect erasure detection check <p>FWD recording possible : "▶" display lights up REV recording possible : "◀" display lights up</p> <ul style="list-style-type: none"> • Timer SW check <p>TIMER REC : "FADE" OFF : "[HI -]" TIMER PLAY : "COPY"</p> <ul style="list-style-type: none"> • Reverse SW check <p>⊕ : "BLE" ⊖ : "I" ⊙ : "II"</p> <ul style="list-style-type: none"> • Sound EQ SW check <p>PORTABLE : "[CD SYNC]" OFF : "RELAY/SKIP" CAR : "PLAY"</p> <ul style="list-style-type: none"> • Tape detection check <p>Side II check</p> <p>NORMAL : Lch + 4dB lights up Rch + 4 dB lights up CrO₂ : Lch + 4 dB turns off Rch + 4 dB lights up METAL : Lch + 4 dB turns off Rch + 4 dB turns off</p> <p>Side I check</p> <p>NORMAL : Lch - 20dB lights up Rch - 20dB lights up CrO₂ : Lch - 20dB turns off Rch - 20dB lights up METAL : Lch - 20dB turns off Rch - 20dB turns off</p>
2	2 400 (Side I)	NORMAL SPEED	OFF	OFF	OFF	OFF	OFF	<p>◇ For AUTO BLE 400 Hz OSC output level adjustment mode</p> <ul style="list-style-type: none"> • Adjust with meter so that -1 dB blink s. (LINE OUT output = -26 dBv) • Meter becomes BLE range.

CT-W801R, CT-W851R, CT-W701R

MODE NO.	Display Side II	Input key	LINE MUTE	2REC MUTE	2 BIAS	1REC MUTE	1 BIAS	Adjustment and Check Contents
3	3 10k (Side I)	HIGH SPEED	OFF	OFF	OFF	OFF	OFF	<ul style="list-style-type: none"> ◇ For AUTO BLE 10 kHz OSC output level adjustment mode • Adjust with meter so that -1 dB blinks. (LINE OUT output = -26 dBv) • Meter becomes BLE range.
4	4 3k (Side I)	2 - BLE	OFF	OFF	OFF	OFF	OFF	<ul style="list-style-type: none"> ◇ For AUTO BLE 3 kHz OSC output level adjustment mode • Adjust with meter so that -1 dB blinks. (LINE OUT output = -26 dBv) • Meter becomes BLE range. Not for 2 POINT BLE.
5	5	FWD REV FF REW	OFF	ON	OFF	ON	OFF	<ul style="list-style-type: none"> ◇ Tape speed adjustment mode • During play (excluding during assist), double speed PLAY is set by inputting the FAST key (FF of either sides I and II or REW key). During double speed PLAY, normal PLAY is set by inputting the FWD or REW key. • PLAY is possible even in the "No Half" condition. ◇ Auto stop check • Only for this mode, the auto stop at sudden tape end is 1 second (Normally 4 seconds). • Normal reverse operations are performed. However if reverse is performed during double speed PLAY, the normal PLAY is set. ◇ BLANK SKIP check • Only for this mode, the BLANK SKIP function operates if the "no signal" condition continues for 4.7 seconds in the "PLAY" condition (Normally 15 seconds.)
6	6	2 - CTR RESET	ON	ON	ON	ON	ON	<ul style="list-style-type: none"> ◇ Erasure current check mode • Erase current check according to TAPE TYPE is possible. "BIAS" blinking display is set.
7	7	2 - CTR MODE	OFF	OFF	OFF	OFF	OFF	<ul style="list-style-type: none"> ◇ Mute off mode Mode which turns both LINE MUTE and REC MUTE off.
8	-	-	-	-	-	-	-	

MODE NO.	Display	Input key	LINE MUTE	2REC MUTE	2 BIAS	1REC MUTE	1 BIAS	Adjustment and Check Contents
9	9	2 - MUTE	ON	ON	ON	ON	OFF	Side II BIAS SWEEP mode (BIAS pattern display)
10	A	2 - PAUSE	OFF	OFF	OFF	ON	OFF	Side II LEVEL SWEEP mode (LEVEL pattern display)
11	b	2 - REC	OFF	OFF	OFF	ON	OFF	Side II EQ SWEEP mode (EQ pattern display)
12	-	-	-	-	-	-	-	_____
13	d	1 - MUTE	ON	ON	OFF	ON	ON	Side I BIAS SWEEP mode (BIAS pattern display)
14	E	1 - PAUSE	OFF	ON	OFF	OFF	OFF	Side I LEVEL SWEEP mode (LEVEL pattern display)
15	F	1 - REC	OFF	ON	OFF	OFF	OFF	Side I EQ SWEEP mode (EQ pattern display)

◇ Setting the test mode

When both sides I and II are in the STOP mode, the test mode can be set by setting the reverse mode SW to \rightleftharpoons mode and short - circuiting the fixed jumper wire.

◇ Releasing the test mode

The test mode can be released by pressing the COUNTER RESET key of side I or turning off the power.

◇ CD SYNCHRO check (Can be checked in any of the above modes.)

- CD SYNCHRO key check.....While the CD SYNCHRO key is pressed, the **REC** display of side II will be lit (Only if a cable is connected to the CD SYNCHRO jack.)
- Input/output signal check.....The **REC** display will light up while the COUNTER MODE key of side I is pressed only if a short - circuited cable is connected to the input/output.

9.12 Demonstration Function

- Mode which performs demonstration display.
- ◇ Accepted Conditions
 - When both sides I and II are in the STOP mode.
- ◇ Operations
 - When both the above conditions are present, the demonstration mode can be set by pressing the 2-COUNTER RESET key and 2-PAUSE key simultaneously.
 - This mode can be released by outputting/inputting the "half", key inputs or turning off the power.

10. CIRCUIT DESCRIPTIONS

● SOUND EQ CIRCUIT

10.1 Purpose

More and more people are recording their favorite music onto cassette tapes and then listening to them using a portable stereo or car stereo.

However, when a tape recorded in the normal way on conventional equipment is played back through a portable stereo or car stereo, the low and high frequency ranges are often not strong enough due to the characteristics of the headphones or the in-car environment.

The new Sound EQ function boosts the level of these frequencies by altering the frequency characteristics of the music signal during recording. This allows users to produce tapes that have sonic characteristics ideal for playback on portable stereos or car stereos.

10.2 Operation

Operation is as simple as setting the SOUND EQ switch to either PORTABLE or CAR, as appropriate, before beginning recording. When the setting is made, the indication PORTABLE or CAR appears on the fluorescent counter display for a few seconds and the level meter changes to show the frequency curve.

10.3 Features

- The frequency characteristics of the line input are changed to match the requirements of portable stereos or car stereos. This has no adverse effects on S/N ratio or distortion levels.
- When Sound EQ is combined with BLE, compensation for the tape's specific characteristics can be performed before recording optimized for portable stereos or car stereos takes place. This ensures that the amount of boost will not vary from one cassette to another, allowing the creation of even more effective tapes.

10.4 Recording Frequency Compensation for Car Stereo Applications

There are many restrictions on where and how speakers can be installed in a car due to the complex configuration of the car interior and its small capacity of around 3 m³ quite small compared with a normal audio listening room. Under these circumstances, car speakers tend to have small-diameter diaphragms. Also, depending on the details of the installation, there may be a great deal of noise that leaks in from behind the speakers. Both of these factors work against the effective reproduction of low frequency sounds.

In addition, the sound spectrum of the noise produced when a car is running shows an increase in intensity at the low end of the frequency range. This low range noise tends to mask the bass portion of the music being played through the speakers. In order to improve the low frequency characteristics peculiar to cars, Sound EQ boosts the level of a frequency band centering on the frequencies between 40 and 50 Hz.

There is also a tendency for treble reproduction to be insufficient in cars due to poor speaker orientation and the presence of objects such as seats that absorb high frequency sounds. To compensate for this, a slight boost in the high range is also added in order to create a sense of increased spaciousness.

10.5 Recording Frequency Compensation for Portable Stereo Applications

The headphones used with portable stereos can not match the bass response of full-sized room speaker systems due to factors such as the smallness of their driver diaphragms, the point at which the electrical music signal is converted into sound waves. To compensate for this, Sound EQ boosts the frequencies centered around 70 Hz. Also, the high frequency reproduction characteristics of headphone stereos are generally inferior to those of standard cassette decks due to factors such as head azimuth misalignment, which can easily occur if the unit is dropped or bumped. To compensate for this, a slight boost in the high range is also added to provide added ambience.

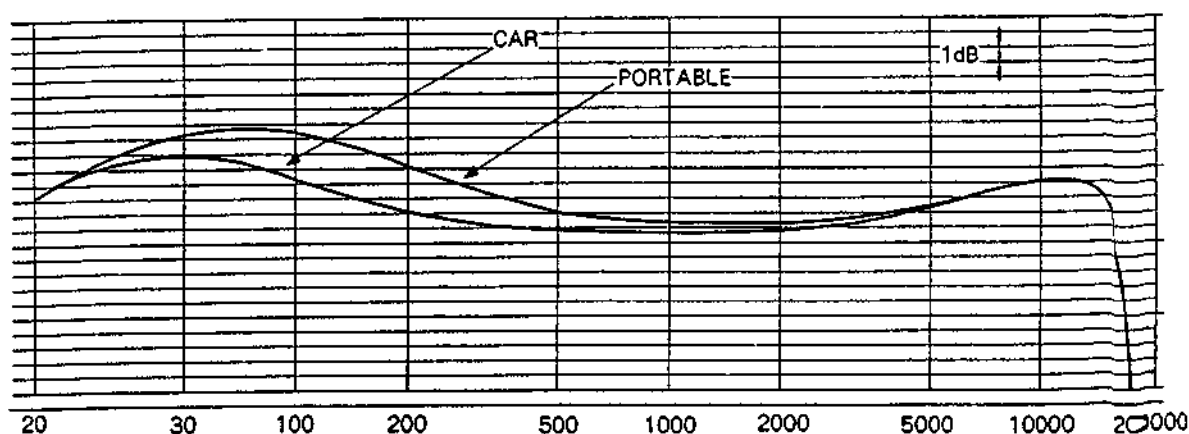

FREQUENCY RESPONSE (LINE) MPX ON

CT-W801R, CT-W851R, CT-W701R

● SUPER AUTO BLE (First Double Deck with a 3-point BLE)

In conventional 2 head units, bias, level and equalizer were tuned using the 2-point AUTO BLE (400 Hz and 10 kHz) to flatten the frequency characteristic. Although most tapes could be flattened by this method, medium band correction (3 kHz) has been added and the dip of medium band which rarely occurs has been improved this time to flatten the frequency characteristic even more. The 3-point BLE has already been used in 3 heads units to perform adjustments. However, this is the first time it is used in a 2 heads unit.

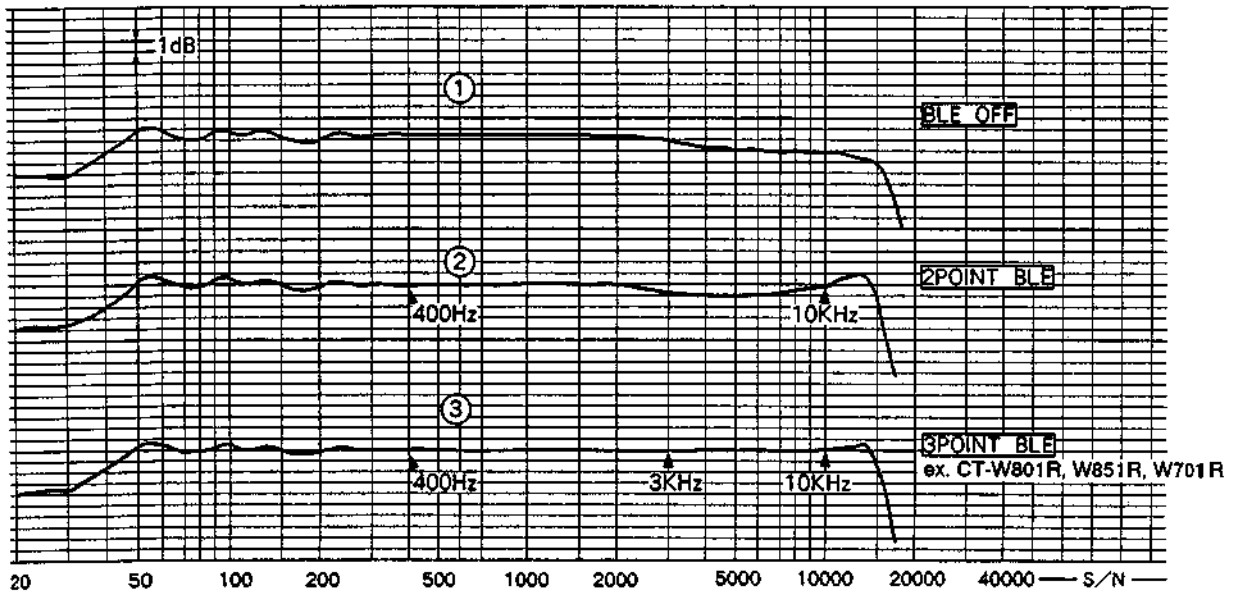

11. FOR CT-W801R/SD, CT-W851R/HEM AND HB TYPES

CONTRAST OF MISCELLANEOUS PARTS

NOTES:

- Parts marked by "NSP" are generally unavailable because they are not in our Master Spare Parts List.
- The Δ mark found on some component parts indicates the importance of the safety factor of the part. Therefore, when replacing, be sure to use parts of identical designation.
- Parts marked by "⊕" are not always kept in stock. Their delivery time may be longer than usual or they may be unavailable.

The CT-W801R/SD, CT-W851R/HEM, HB and CT-W801R/KUC have the same construction except for the following:

Mark	Symbol & Description	Part No.				Remarks
		CT-W801R/ KUC type	CT-W801R/ SD type	CT-W851R/ HEM type	CT-W851R/ HB type	
⊕	Mother unit	RWM1471	RWM1539	RWM1472	RWM1472	
NSP	MAIN unit	RWZ2486	RWZ2685	RWZ2505	RWZ2505	
NSP	HP, MIC unit	RWZ2487	RWZ2686	RWZ2506	RWZ2506	
NSP	OPERATE SW(1) unit	RWZ2488	RWZ2687	RWZ2507	RWZ2507	
NSP	OPERATE SW(2) unit	RWZ2489	RWZ2688	RWZ2508	RWZ2508	
NSP	DISPLAY unit	RWZ2490	RWZ2689	RWZ2509	RWZ2509	
NSP	TR SEC unit	RWZ2491	RWZ2690	RWZ2510	RWZ2510	
Δ	Strain relief	CM - 22C	CM - 22B	CM - 22B	CM - 22B	
Δ	AC power cord	PDG1015	PDG1013	PDG1003	PDG1038	
Δ	Power transformer (AC120V)	RTT1165	
Δ	Power transformer (AC110/120 - 127/220/240V)	RTT1167	
Δ	Power transformer (AC220 - 230/230 - 240V)	RTT1166	RTT1166	
Δ	FU1, FU2 Fuse (1.5A)	REK1001	
Δ	FU1, FU2 Fuse (T1.8A)	REK - 102	REK - 102	REK - 102	
Δ	Voltage selector (AC110/120 - 127/220/240V)	PSB1002	
	FL lens	RAH2079	RAH2079	RAH2080	RAH2080	
	Front panel assembly	RXX1518	RXX1518	RXX1517	RXX1517	
⊕	Mechanism unit (Deck I)	RYM1169	RYM1169	RYM1172	RYM1172	
⊕	Mechanism unit (Deck II)	RYM1170	RYM1170	RYM1173	RYM1173	
NSP	Rear panel	RNA1569	RNA1572	RNA1570	RNA1571	
NSP	SW bracket	RNE1441	
NSP	Capacitor sleeve A	REC - 150	REC - 150	REC - 150	(for C1203)
NSP	Front panel	RAH2065	RAH2065	RAH2066	RAH2066	
	Packing case	RHG1368	RHG1370	RHG1369	RHG1369	
	Connection cord (with mini plug)	PDE - 319	PDE - 319	
	Remote control unit	RPX1057	RPX1057	
	Battery cover	PZN1010	PZN1010	
	Operating instructions (English)	RRB1120	RRB1120	
	Operating instructions (Spanish)	RRD1123	
	Operating instructions (French/German/Italian/ Dutch/Swedish/Spanish/Portuguese)	RRE1063	

MAIN UNIT

RWZ2685, RWZ2505 and RWZ2486 have the same construction except for the following:

Mark	Symbol & Description	Part No.			Remarks
		RWZ2486	RWZ2685	RWZ2505	
	D910-912 C910 R719, 720 JA902, 903	1SS254 CKCYF103Z50 RD1/6PM332J RKN1004	1SS254 CKCYF103Z50 RD1/6PM222J RKN1004 RD1/6PM222J	

DISPLAY UNIT

RWZ2509 and RWZ2490 have the same construction except for the following:

Mark	Symbol & Description	Part No.		Remarks
		RWZ2490	RWZ2509	
	V1501	RAW1105	RAW1107	

Note: Although RWZ2689 and RWZ2490 are different in part number, they have the same service parts.

OPERATE SW(1) UNIT

Although RWZ2687, RWZ2507 and RWZ2488 are different in part number, they have the same service parts.

OPERATE SW(2) UNIT

Although RWZ2688, RWZ2508 and RWZ2489 are different in part number, they have the same service parts.

HP, MIC UNIT

Although RWZ2506, RWZ2686 and RWZ2487 are different in part number, they have the same service parts.

TR SEC UNIT

Although RWZ2690, RWZ2510 and RWZ2491 are different in part number, they have the same service parts.

MECHANISM UNIT(DECK I)

RYM1172 and RYM1169 have the same construction except for the following:

Mark	Symbol & Description	Part No.		Remarks
		RYM1169	RYM1172	
	BELT MAIN ASS'Y FLYWHEEL L ASS'Y FLYWHEEL R ASS'Y MOTOR GEAR FW R FLYWHEEL R	REB1159 RXA1423 RXA1424 RXM1052	REB1162 RXA1476 RXM1051 RNK1733 RXA1415	

MECHANISM UNIT(DECK II)

RYM1173 and RYM1170 have the same construction except for the following:

Mark	Symbol & Description	Part No.		Remarks
		RYM1170	RYM1173	
	BELT MAIN ASS'Y FLYWHEEL L ASS'Y FLYWHEEL R ASS'Y MOTOR GEAR FW R FLYWHEEL R	REB1159 RXA1423 RXA1424 RXM1052	REB1162 RXA1476 RXM1051 RNK1733 RXA1415	

12. FOR CT-W701R/HEM AND HB TYPES

CONTRAST OF MISCELLANEOUS PARTS

NOTES:

- Parts marked by "NSP" are generally unavailable because they are not in our Master Spare Parts List.
- The Δ mark found on some component parts indicates the importance of the safety factor of the part. Therefore, when replacing, be sure to use parts of identical designation.
- Parts marked by "⊙" are not always kept in stock. Their delivery time may be longer than usual or they may be unavailable.

The CT-W701R/HEM, HB and CT-W701/KUC have the same construction except for the following:

Mark	Symbol & Description	Part No.			Remarks
		CT-W701R KUC type	CT-W701R/ HEM type	CT-W701R/ HB type	
⊙	Mother unit	RWM1473	RWM1474	RWM1474	
NSP	MAIN unit	RWZ2511	RWZ2517	RWZ2517	
NSP	HP unit	RWZ2512	RWZ2518	RWZ2518	
NSP	OPERATE SW(1) unit	RWZ2513	RWZ2519	RWZ2519	
NSP	OPERATE SW(2) unit	RWZ2514	RWZ2520	RWZ2520	
NSP	DISPLAY unit	RWZ2515	RWZ2521	RWZ2521	
NSP	TR SEC unit	RWZ2516	RWZ2522	RWZ2522	
Δ	Strain relief	CM - 22C	CM - 22B	CM - 22B	
Δ	AC power cord	PDG1015	PDG1003	PDG1036	
Δ	Power transformer (AC120V)	RTT1165	
Δ	Power transformer (AC220 - 230/230 - 240V)	RTT1166	RTT1166	
Δ	FU1, FU2 Fuse (1.5A)	REK1001	
Δ	FU1, FU2 Fuse (T1.6A)	REK - 102	REK - 102	
Δ	FL lens	RAH2079	RAH2081	RAH2081	
⊙	Mechanism unit (Deck I)	RYM1169	RYM1172	RYM1172	
⊙	Mechanism unit (Deck II)	RYM1170	RYM1173	RYM1173	
	Insulator	PNW1912	PNW1912	
	Foot assembly	PXA1201	
NSP	Rear panel	RNA1573	RNA1574	RNA1575	
NSP	SW bracket	RNE1441	
NSP	Capacitor sleeve A	REC - 150	REC - 150	(for C1203)
	Packing case	RHG1371	RHG1372	RHG1372	
	Operating instructions (English)	RRB1120	RRB1120	
	Operating instructions (French/German/Italian/Dutch/Swedish/ Spanish/Portuguese)	RRE1063	

MAIN UNIT

RWZ2517 and RWZ2511 have the same construction except for the following:

Mark	Symbol & Description	Part No.		Remarks
		RWZ2511	RWZ2517	
	R719, 720	RD1/6PM332J	RD1/6PM222J	

DISPLAY UNIT

RWZ2521 and RWZ2515 have the same construction except for the following:

Mark	Symbol & Description	Part No.		Remarks
		RWZ2515	RWZ2521	
	V1501	RAW1105	RAW1107	

OPERATE SW(1) UNIT

Although RWZ2519 and RWZ2513 are different in part number, they have the same service parts.

OPERATE SW(2) UNIT

Although RWZ2520 and RWZ2514 are different in part number, they have the same service parts.

HP UNIT

Although RWZ2518 and RWZ2512 are different in part number, they have the same service parts.

TR SEC UNIT

Although RWZ2522 and RWZ2516 are different in part number, they have the same service parts.

MECHANISM UNIT(DECK I)

RYM1172 and RYM1169 have the same construction except for the following:

Mark	Symbol & Description	Part No.		Remarks
		RYM1169	RYM1172	
	BELT MAIN ASS'Y FLYWHEEL L ASS'Y FLYWHEEL R ASS'Y MOTOR GEAR FW R FLYWHEEL R	REB1159 RXA1423 RXA1424 RXM1052	REB1162 RXA1476 RXM1051 RNK1733 RXA1415	

MECHANISM UNIT(DECK II)

RYM1173 and RYM1170 have the same construction except for the following:

Mark	Symbol & Description	Part No.		Remarks
		RYM1170	RYM1173	
	BELT MAIN ASS'Y FLYWHEEL L ASS'Y FLYWHEEL R ASS'Y MOTOR GEAR FW R FLYWHEEL R	REB1159 RXA1423 RXA1424 RXM1052	REB1162 RXA1476 RXM1051 RNK1733 RXA1415	

13. PANEL FACILITIES

The illustration shows model CT-W851R.

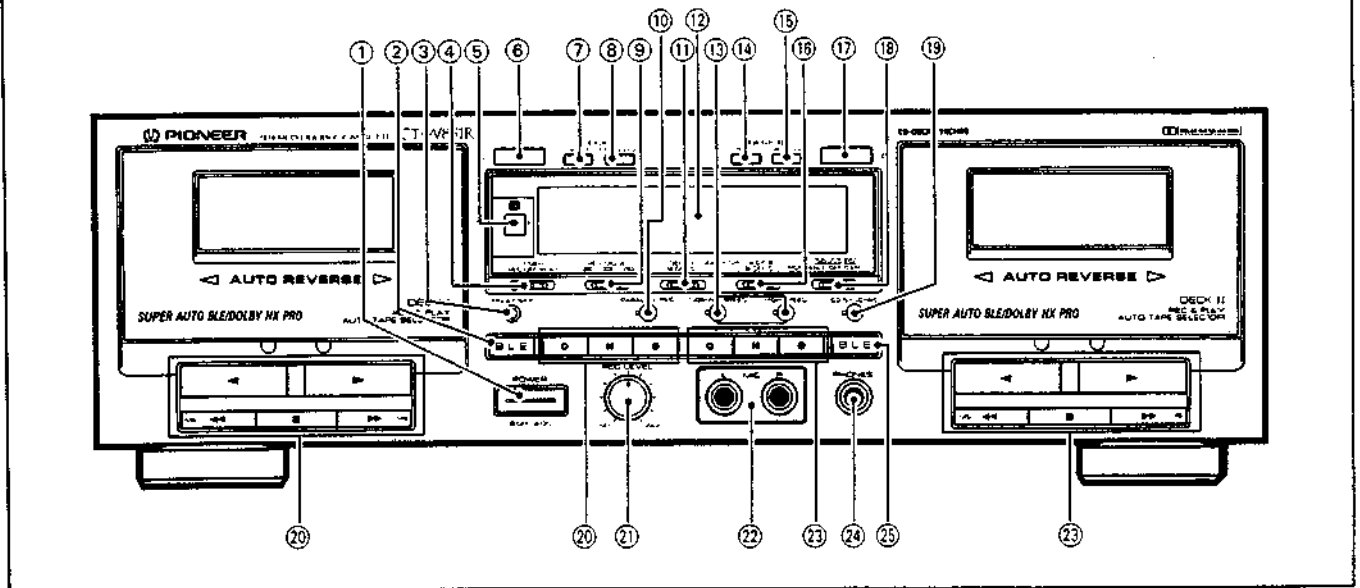

- ① POWER switch (■ OFF/ ■ ON)
- ② DECK I AUTO BLE button
- ③ RELAY/SKIP button
- ④ TIMER mode switch (REC/OFF/PLAY)
- ⑤ Remote sensor (CT-W851R only)
- ⑥ DECK I eject button (▲)
 - If the tape is moving (recording, playback, tape winding etc.), press the stop (■) button before pressing this button.

NOTE:
If the power is turned off while the tape is moving, the cassette door may remain locked. In this case, turn the power on before pressing the eject (▲) button.
- ⑦ DECK I counter reset button (RESET)
- ⑧ DECK I counter mode button (TIME/COUNT)
- ⑨ Reverse mode switch (REV MODE)
- ⑩ Parallel recording button (PARALLEL REC) (CT-W851R/CT-W801R only)
- ⑪ DECK I DOLBY* NR switch (B/OFF/C)
 - *
• Dolby noise reduction and HX Pro headroom extension manufactured under license from Dolby Laboratories Licensing Corporation. HX Pro originated by Bang & Olufsen.
• "DOLBY", the double-D symbol and "HX PRO" are trademarks of Dolby Laboratories Licensing Corporation.
- ⑫ Function display
- ⑬ Synchro copy buttons (SYNCHRO COPY I ► II)
NORMAL SPEED: Normal speed copy
HIGH SPEED : Double speed copy
- ⑭ DECK II counter reset button (RESET)
- ⑮ DECK II counter mode button (TIME/COUNT)
- ⑯ DECK II DOLBY* NR switch (B/OFF/C)
- ⑰ DECK II eject button (▲)
 - If the tape is moving (recording, playback, tape winding etc.), press the stop (■) button before pressing this button.

NOTE:
If the power is turned off while the tape is moving, the cassette door may remain locked. In this case, turn the power on before pressing the eject (▲) button.
- ⑱ SOUND EQ switch (PORTABLE/OFF/CAR)
- ⑲ CD+DECK SYNCHRO recording button (CD SYNCHRO)
- ⑳ DECK I operation buttons
 - ◀ : Reverse playback
 - ▶ : Forward playback
 - ◀◀/MS : Fast reverse/music search
 - : Stop
 - ▶▶/MS : Fast forward/music search
 - : Recording mute
 - ▬▬ : Pause
 - : Recording
- ㉑ Recording level control (REC LEVEL)
- ㉒ Microphone jacks (MIC L,R) (CT-W851R/CT-W801R only)
- ㉓ DECK II operation buttons
 - ◀ : Reverse playback
 - ▶ : Forward playback
 - ◀◀/MS : Fast reverse/music search
 - : Stop
 - ▶▶/MS : Fast forward/music search
 - : Recording mute
 - ▬▬ : Pause
 - : Recording
- ㉔ Headphones jack (PHONES)
- ㉕ DECK II AUTO BLE button

14. SPECIFICATIONS

System	4 track, 2-channel stereo
Heads	"Hard Permalloy" recording/playback head × 2 "Ferrite" erasing head × 2
Motor	DC servo motor × 2
Wow and Flutter	No more than 0.09% (WRMS) No more than ±0.19% (DIN)
Fast Winding Time	Approximately 120 seconds (C-60 tape)

Frequency Response	
- 20 dB recording:	
TYPE IV (Metal) tape	25 to 20,000 Hz
TYPE II (Chrome) tape	25 to 19,000 Hz
TYPE I (Normal) tape	25 to 18,000 Hz
Signal-to-Noise Ratio	
Dolby NR OFF	More than 57 dB
Noise Reduction Effect	
Dolby B-type NR ON	More than 10 dB (at 5 kHz)
Dolby C-type NR ON	More than 19 dB (at 5 kHz)
Harmonic Distortion	No more than 0.8% (at -4 dB: 160 nwb/m)

Input (Sensitivity)	
LINE (INPUT)	100 mV (Input impedance 38 kΩ)
MIC	0.63 mV (CT-W851R/CT-W801R only)
Output (Reference level)	
LINE (OUTPUT)	0.5 V (Output impedance 3.2 kΩ)
Headphone	0.63 mW (Load impedance 8 Ω)

Subfunctions

- AUTO BLE tuning system
- Automatic reverse
- Double recording/playback reverse
- DOLBY HX PRO recording function
- DOLBY B/C types NR
- Relay recording
- Parallel recording (CT-W851R/CT-W801R only)
- Music search over ±15 selections
- Synchronized copy start
- High-speed and normal-speed copy (DECK I→DECK II)
- Relay playback/blank skip
- CD+DECK SYNCHRO recording capability
- Peak level meter with peak-hold function
- MPX FILTER (Interlocks with DOLBY NR switch)
- Automatic space recording mute
- Automatic tape selector
- **SR** System remote control available
(CT-W801R/CT-W701R only)
- TIMER Recording
- TIMER Playback (Automatic relay on)
- 2-mode electronic 4-digit twin tape counter
- Microphone jacks (CT-W851R/CT-W801R only)
- Headphone jack
- Wireless remote control operation (CT-W851R only)
- SOUND EQ function

Miscellaneous

Power Requirements	
U.S., Canadian models	AC 120V, 60 Hz
U.K. model	AC 230-240 Volts~, 50/60 Hz
Multivoltage model	AC 110V/120V-127V/220V/240V (switchable), 50/60 Hz

Power Consumption	
CT-W851R/CT-W801R	26W
CT-W701R	17W

Dimensions	
CT-W851R/CT-W801R	420(W) × 135(H) × 250(D) mm
CT-W701R	
U.S. and Canadian model	420(W) × 130(H) × 250(D) mm 16-2/4(W) × 5(H) × 9-13/16(D) in
U.K. model	420(W) × 135(H) × 250(D) mm
Weight (without package)	
CT-W851R/CT-W801R	4.7 kg (10 lb 5 oz.)
CT-W701R	4.6 kg (10 lb 2 oz.)

Accessories

Operating instructions	1
Connection cord with pin plugs	2
SR Remote control cord (CT-W801R/CT-W701R only)	1
CD+DECK SYNCHRO control cord	1
Remote control unit (CT-W851R only)	1
Dry cell batteries (size AAA/IEC R03) (CT-W851R only)	2

NOTE:

Specifications and design subject to possible modifications without notice, due to improvements.