

Service Manual

PIONEER
The Art of Entertainment

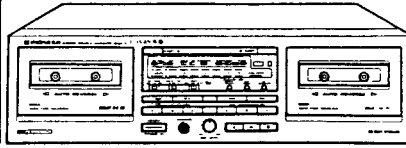

ORDER NO.
ARP2150

STEREO DOUBLE CASSETTE DECK

CT-W450R

CT-W355R

CT-W350R

CT-W450R, CT-W355R AND CT-W350R HAVE THE FOLLOWING:

Type	Model			Power Requirement	Remarks
	CT-W450R	CT-W355R	CT-W350R		
KUC	○	○	○	AC120V only	
KUCXJ	○	○	○	AC120V only	
HEMXJ	-	-	○	AC220-230V, 230-240V (switchable) *	
HB	-	-	○	AC220-230V, 230-240V (switchable) *	
HBXJ	-	-	○	AC220-230V, 230-240V (switchable) *	
HPWXJ	-	-	○	AC220-230V, 230-240V (switchable) *	
SDXJ	-	-	○	AC110V, 120-127V, 220V, 240V (switchable)	

* Change the primary wiring of the power transformer.

- This manual is applicable to the CT-W450R/KUC, KUCXJ, CT-W355R/KUC, KUCXJ, CT-W350R/KUC, KUCXJ, HEMXJ, HB, HBXJ, HPWXJ and SDXJ types.
- As to the CT-W450R/KUCXJ, CT-W355R/KUC, KUCXJ, CT-W350R/KUC, KUCXJ, HEMXJ, HB, HBXJ, HPWXJ and SDXJ types, refer to page 41-44.
- Ce manuel pour le service comprend les explications de réglage en français.
- Este manual de servicio trata del método ajuste escrito en español.

PIONEER ELECTRONIC CORPORATION 4-1, Meguro 1-Chome, Meguro-ku, Tokyo 153, Japan
PIONEER ELECTRONICS SERVICE INC. P.O. Box 1760, Long Beach, California 90801 U.S.A.
PIONEER ELECTRONICS OF CANADA, INC. 505 Cochrane Drive, Markham, Ontario L3R 8E3 Canada
PIONEER ELECTRONIC [EUROPE] N.V. Keetberglaan 1, 2740 Beveren, Belgium
PIONEER ELECTRONICS AUSTRALIA PTY. LTD. 178-184 Boundary Road, Braeside, Victoria 3195, Australia TEL: [03] 580-9911
 © PIONEER ELECTRONIC CORPORATION 1991

SI MAR. 1991 Printed in Japan

CONTENTS

1. SAFETY INFORMATION	2	6. RÉGLAGE	33
2. EXPLODED VIEWS, PACKING AND PARTS LIST.....	3	6. AJUSTE	37
3. P.C. BOARDS CONNECTION DIAGRAM	19	7. FOR CT-W450R/KUCXJ, CT-W355R/KUC, KUCXJ, CT-W350R/KUC, KUCXJ, HEMXJ, HB, HBXJ, HPWXJ AND SDXJ TYPES.....	41
4. SCHEMATIC DIAGRAM.....	23	8. SPECIFICATIONS	44
5. PCB's PARTS LIST	26	9. PANEL FACILITIES.....	46
6. ADJUSTMENTS	30		

This service manual is intended for qualified service technicians; it is not meant for the casual do-it-yourselfer. Qualified technicians have the necessary test equipment and tools, and have been trained to properly and safely repair complex products such as those covered by this manual.

Improperly performed repairs can adversely affect the safety and reliability of the product and may void the warranty. If you are not qualified to perform the repair of this product properly and safely, you should not risk trying to do so and refer the repair to a qualified service technician.

WARNING

Lead in solder used in this product is listed by the California Health and Welfare agency as a known reproductive toxicant which may cause birth defects or other reproductive harm (California Health & Safety Code, Section 25249.5).

When servicing or handling circuit boards and other components which contain lead in solder, avoid unprotected skin contact with the solder. Also, when soldering do not inhale any smoke or fumes produced.

1. SAFETY INFORMATION

(FOR USA MODEL ONLY)

1. SAFETY PRECAUTIONS

The following check should be performed for the continued protection of the customer and service technician.

LEAKAGE CURRENT CHECK

Measure leakage current to a known earth ground (water pipe, conduit, etc.) by connecting a leakage current tester such as Simpson Model 229-2 or equivalent between the earth ground and all exposed metal parts of the appliance (input/output terminals, screwheads, metal overlays, control shaft, etc.). Plug the AC line cord of the appliance directly into a 120V AC 60Hz outlet and turn the AC power switch on. Any current measured must not exceed 0.5mA.

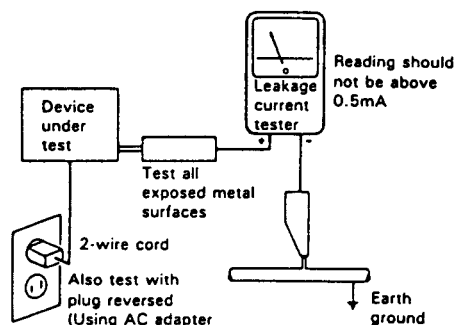

AC Leakage Test

ANY MEASUREMENTS NOT WITHIN THE LIMITS OUTLINED ABOVE ARE INDICATIVE OF A POTENTIAL SHOCK HAZARD AND MUST BE CORRECTED BEFORE RETURNING THE APPLIANCE TO THE CUSTOMER.

2. PRODUCT SAFETY NOTICE

Many electrical and mechanical parts in the appliance have special safety related characteristics. These are often not evident from visual inspection nor the protection afforded by them necessarily can be obtained by using replacement components rated for voltage, wattage, etc. Replacement parts which have these special safety characteristics are identified in this Service Manual.

Electrical components having such features are identified by marking with a Δ on the schematics and on the parts list in this Service Manual.

The use of a substitute replacement component which does not have the same safety characteristics as the PIONEER recommended replacement one, shown in the parts list in this Service Manual, may create shock, fire, or other hazards.

Product Safety is continuously under review and new instructions are issued from time to time. For the latest information, always consult the current PIONEER Service Manual. A subscription to, or additional copies of, PIONEER Service Manual may be obtained at a nominal charge from PIONEER.

2. EXPLODED VIEWS, PACKING AND PARTS LIST

2.1 Exterior

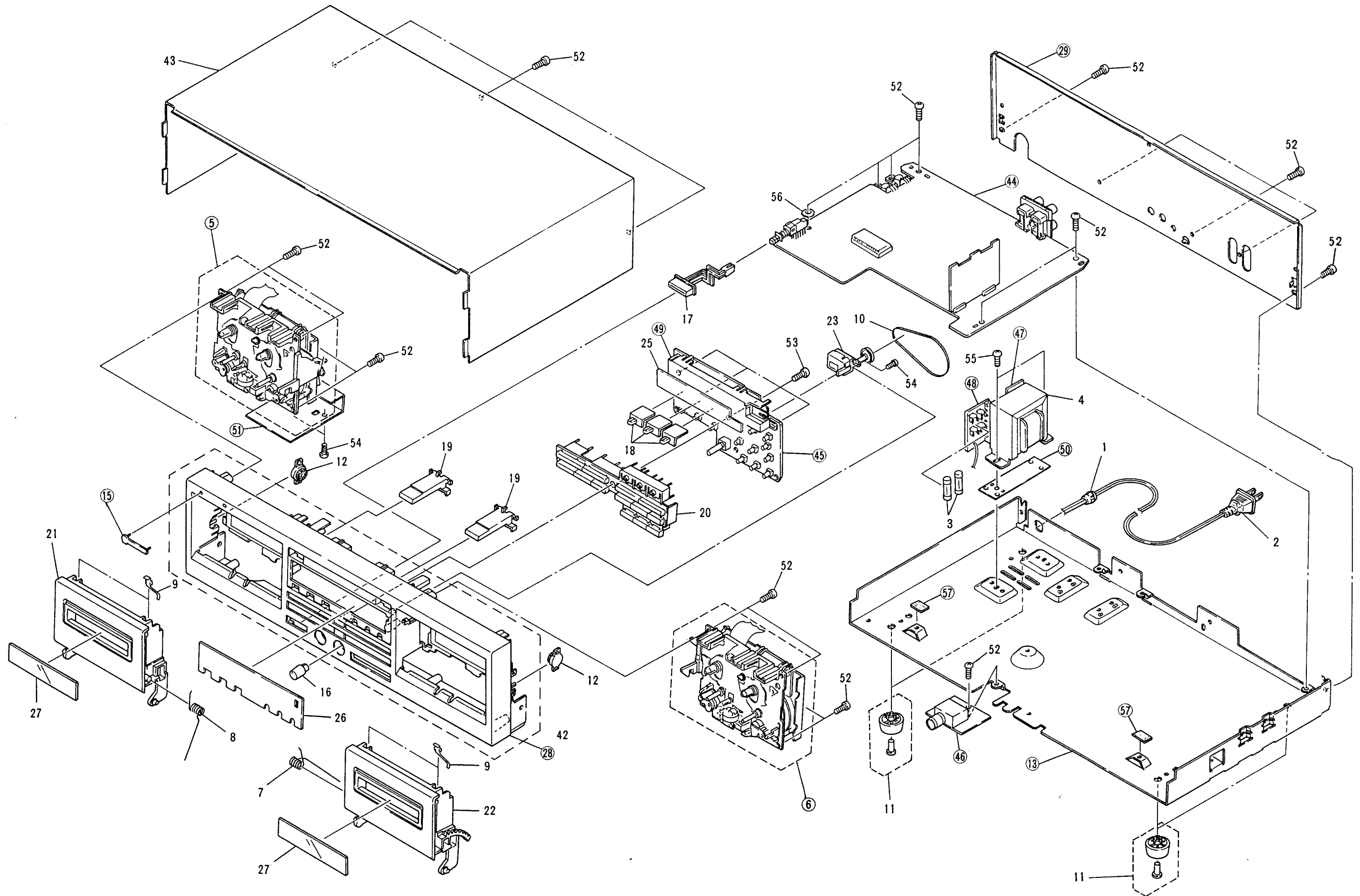

Mark	No.	Description	Part No.
Parts List			
△	1	STRAIN RELIEF	CM - 22
△	2	AC POWER CODE	RDG1010
△	3	FUSE (1.25A)	REK - 073
△	4	POWER TRANSFORMER	RTT1142
	5	MECHANISM UNIT (DECK I)	
	6	MECHANISM UNIT (DECK II)	
	7	DOOR SPRING L	RBH1254
	8	DOOR SPRING R	RBH1255
	9	HALF PRESSURE SPRING	RBK1004
	10	COUNTER BELT	REB1152
	11	LEG ASS'Y	REC - 369
	12	DAMPER ASSEMBLY	REC1005
	13	MAIN CHASSIS	
	14	CORD CLAMPER	RNH - 184
	15	NAME PLATE	
	16	VR KNOB (B)	RAC1421
	17	POWER KNOB	RAC1558
	18	SLIDE KNOB	RAC1559
	19	EJECT KNOB	RAC1560
	20	OPERATION KNOB	RAC1561
	21	DOOR POCKET (L)	RAH1751
	22	DOOR POCKET (R)	RAH1789
	23	COUNTER	RAW1001
	24	REMAIN DISPLAY PAPER	REE - 113
	25	METER PANEL	RAH1753
	26	METER LENS	RAH1882
	27	DOOR LENS	RAH1755
	28	FRONT PANEL	
	29	REAR PANEL	
	30	CONNECTION CORD (WITH MINI PLUG)	PDE - 319
	31	CONNECTION CORD ASSEMBLY	
	32	CONTROL CORD	RDE1018
	33	OPERATING INSTRUCTIONS	RRB1077
	34	PAD (L)	RHA1056
	35	PAD (R)	RHA1057
	36	PACKING CASE	RHG1228
	37	SHEET	RHX - 034
	38	SCREW	BBZ30P080FMC
	39	SCREW	BBZ30P080FMC
	40	
	41	CONNECTION CORD	RDE - 010
	42	FRONT PANEL ASS'Y	RXX1347
	43	BONNET	RXX1351
	44	MAIN UNIT	
	45	SUB UNIT	

Mark	No.	Description	Part No.
	46	H.PHONE UNIT	
	47	TRANS 1 UNIT	
	48	TRANS 2 UNIT	
	49	LED HOLDER	
	50	TRANS SHIELD PLATE	
	51	SHIELD PLATE	
	52	SCREW	BBZ30P080FMC
	53	SCREW	BBZ30P100FZK
	54	SCREW	BBZ20P060FMC
	55	SCREW	ARZ30P080FMC
	56	WASHER	WA30F150M080
	57	SPACER	

Packing

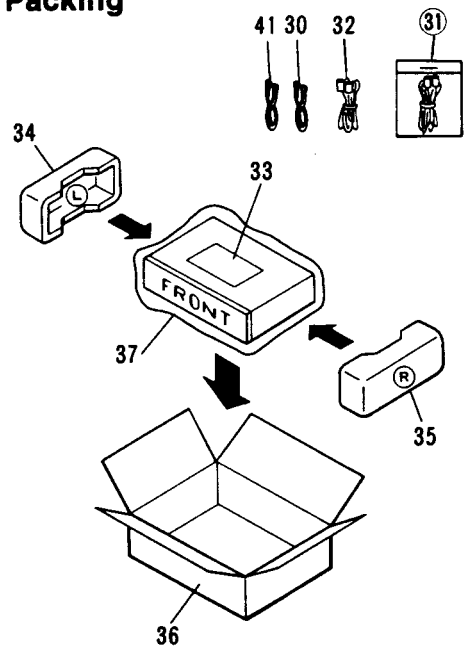

CT-W450R, CT-W350R

Mark No.	Description	Part No.	Mark No.	Description	Part No.
----------	-------------	----------	----------	-------------	----------

2.2 MECHANISM UNIT (DECK I) (For CT-W450R and CT-W350R types)

Parts List

1	ASS'Y HOLDER HEAD	RXA1400	41	BRACKET FW	RNE1438
2	FLAME HEAD	RNK1715	42	
3	LEVER HEAD	RNK1716	43	ASS'Y MOTOR	RXM1052
4	SPRING AZIMUTH	RBK1006	44	WIRE	
5	ASS'Y ARM ASSIST	RXA1401	45	BELT MAIN (OTHERS)	REB1159
				BELT MAIN	REB1162
				(CT - W350R/HB, HBXJ, HEMXJ)	
6	GEAR ARM HEAD	RNK1717	46	P.C. BOARD	RNP1348
7	SPRING CASSETTE	RBK1039	47	HOUSING	RKP1396
8	EJECT LOCK	RNK1718	48	EJECT LEVER R	RNK1703
9	CAP REEL	RNK1719	49	COLLAR	RNK1704
10	ASS'Y PINCH ARM L	RXA1403	50	WIRE HEAD	RKP1398
11	CHASSIS HEAD	RNE1437	61	SPRING	RBH1282
12	ASS'Y PINCH ARM R	RXA1404	62	SPRING	RBH1283
13	ASS'Y ARM PLAY L	RXA1405	63	SPRING	RBH1284
14	GEAR PLAY	RNK1720	64	SPRING	RBH1286
15	ASS'Y ARM PLAY R	RXA1406	65	SPRING	RBH1288
16	CHASSIS OS.	RXA1411	66	SPRING	RBH1290
17	ASS'Y SUB REEL L	RXA1407	67	SPRING	RBH1285
18	SOLENOID	RXP1017	68	SPRING	RBH1287
19	WIRE	RDC1006	69	SPRING	RBH1289
20	ARM RVS	RNK1721	70	SPRING	RBH1291
21	GEAR FF	RNK1723	71	SPRING	RBH1292
22	ASS'Y ARM FR	RXA1412	72	SPRING	RBH1061
23	ASS'Y PULLEY FR	RXA1413	73	SPRING	RBH1060
24	BELT FR	REB1158	74	SPRING	RBH1293
25	METAL	RNG1048	81	SCREW	RBA1023
26	ASS'Y FLYWHEEL L	RXA1409	82	SCREW	RBA1027
	(OTHERS)		83	SCREW	RBA1030
	ASS'Y FLYWHEEL L	RXA1423	84	SCREW	PCZ20P040FMC
	(CT - W350R/HB, HBXJ, HEMXJ)		85	SCREW	RBA1093
27	METAL	RNG1005	86	SCREW	RBA1094
28	ARM BRAKE	RNK1724	87	SCREW	RBA1086
29	ASS'Y SUB REEL R	RXA1408	88	SCREW	RBA1095
30	ARM TRIGGER	RNK1722	101	WASHER	RBF1044
31	GEAR CAM	RNK1725	102	WASHER	WA16D032D025
32	METAL	RNG1049	103	WASHER	WA26D047D013
33	ASS'Y FLYWHEEL R	RXA1410			
	(OTHERS)				
	ASS'Y FLYWHEEL R	RXA1424			
	(CT - W350R/HB, HBXJ, HEMXJ)				
34	METAL	RNG1004			
35	WIRE (12P)	RDD1216			
36	HOLDER WIRE				
37	P.C. BOARD	RNP1347			
38	SWITCH MODE	RSN1020			
39	SWITCH (LEAF)	RSN1019			
40	HALL IC.	DN6851A			

Mechanism Unit (Deck I)
(For CT-W450R and CT-W350R types)

A

B

C

D

A

B

C

D

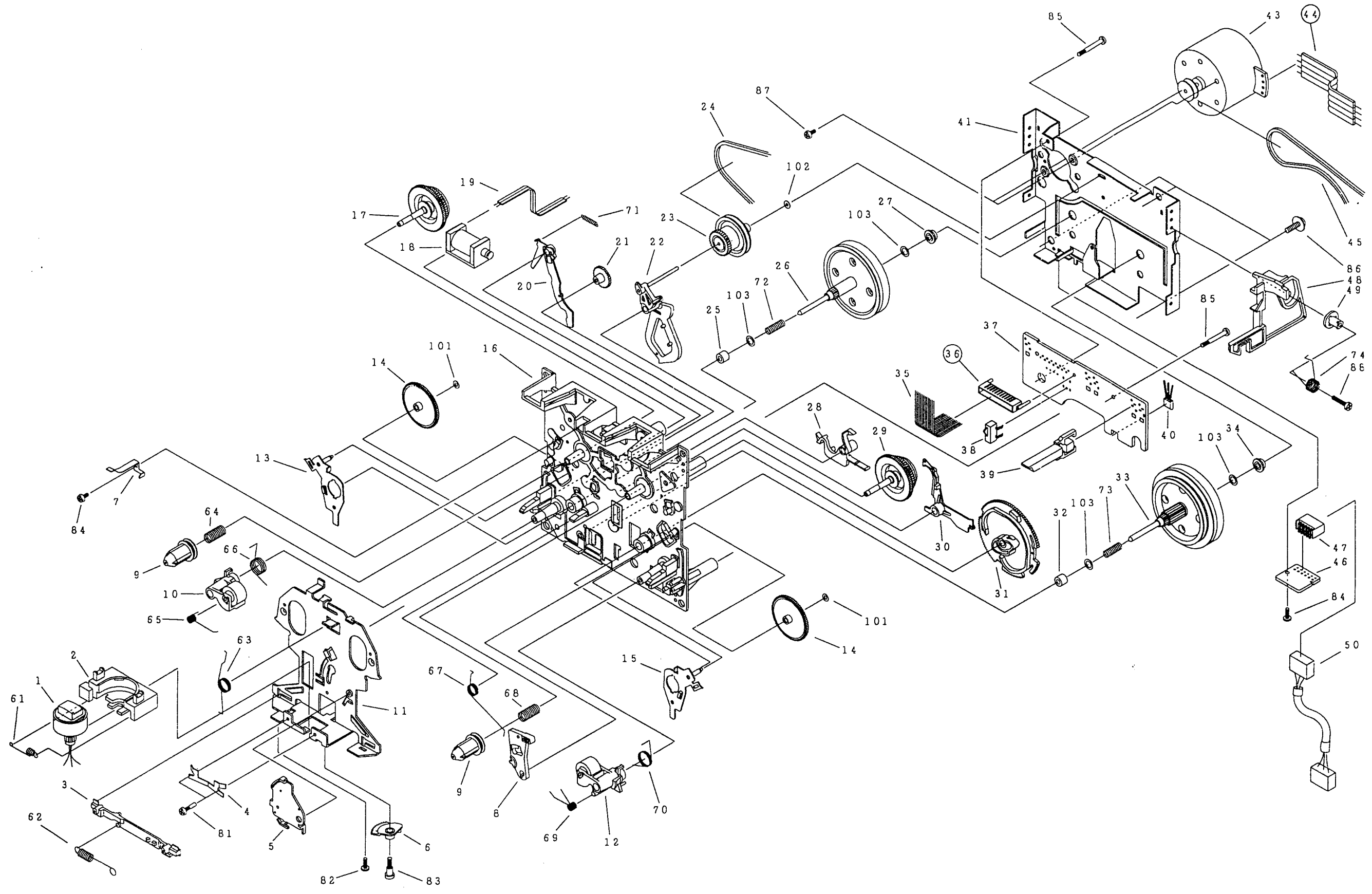

7

1

2

3

4

5

6

D

2.3 Mechanism Unit (DECK I)
(For CT-W355R type)

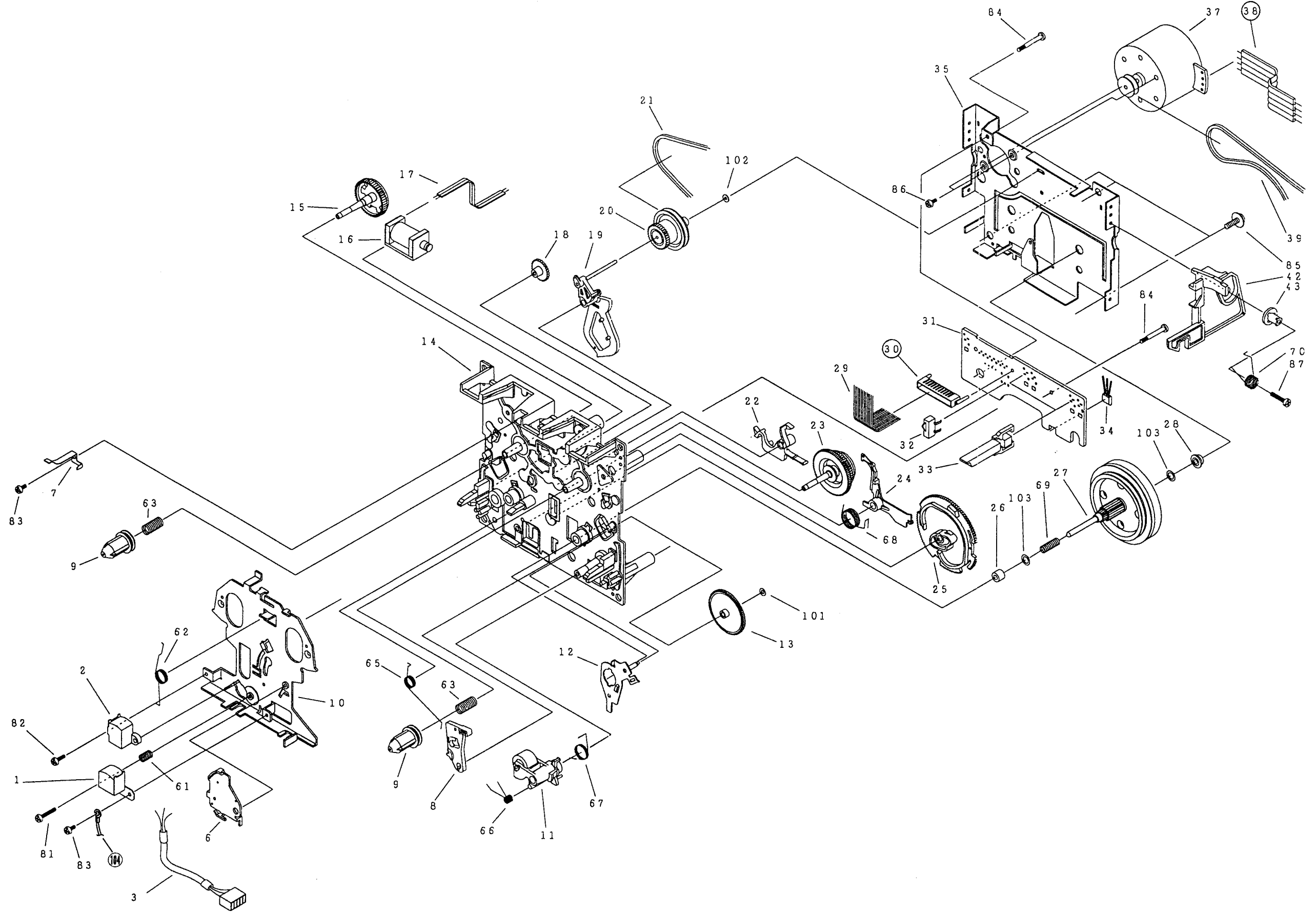

Mark	No.	Description	Part No.	Mark	No.	Description	Part No.
Parts List							
	1	R/P HEAD	RPB1026	81	SCREW		RBA1096
	2	DUMMY HEAD	PNK1458	82	SCREW		RBA1029
	3	WIRE HEAD	RKP1400	83	SCREW		PCZ20P040FMC
	6	ASS'Y ARM ASSIST	RXA1401	84	SCREW		RBA1093
	7	SPRING CASSETTE	RBK1039	85	SCREW		RBA1094
	8	EJECT LOCK	RNK1718	86	SCREW		RBA1086
	9	CAP REEL	RNK1719	87	SCREW		RBA1095
	10	CHASSIS HEAD	RNE1439	101	WASHER		RBF1044
	11	ASS'Y PINCH ARM R	RXA1404	102	WASHER		WA16D032D025
	12	ASS'Y ARM PLAY R	RXA1406	103	WASHER		WA26D047D013
	13	GEAR PLAY	RNK1720	104	LOG PLATE		
	14	CHASSIS OS.	RXA1417				
	15	REEL GEAR	RNK1726				
△	16	SOLENOID	RXP1017				
	17	WIRE	RDC1006				
	18	GEAR FF	RNK1723				
	19	ASS'Y ARM FR	RXA1412				
	20	ASS'Y PULLEY FR	RXA1413				
	21	BELT FR	REB1158				
	22	ARM BRAKE	RNK1724				
	23	ASS'Y SUB REEL R	RXA1408				
	24	ARM TRIGGER	RNK1722				
	25	GEAR CAM	RNK1725				
	26	METAL	RNG1049				
	27	ASS'Y FLYWHEEL R	RXA1424				
	28	METAL	RNG1004				
	29	WIRE (12P)	RDD1216				
	30	HOLDER WIRE					
	31	P.C. BOARD	RNP1347				
	32	SWITCH MODE	RSN1020				
	33	SWITCH (LEAF)	RSN1019				
	34	HALL IC.	DN6851A				
	35	BRACKET FW	RNE1438				
	37	ASS'Y MOTOR	RXM1052				
	38	WIRE					
	39	BELT MAIN	REB1160				
	42	EJECT LEVER R	RNK1703				
	43	COLLAR	RNK1704				
	61	SPRING	RBH1296				
	62	SPRING	RBH1284				
	63	SPRING	RBH1286				
	64					
	65	SPRING	RBH1285				
	66	SPRING	RBH1298				
	67	SPRING	RBH1291				
	68	SPRING	RBH1295				
	69	SPRING	RBH1060				
	70	SPRING	RBH1293				

CT-W450R, CT-W355R, CT-W350R

Mark No.	Description	Part No.
----------	-------------	----------

Mark No.	Description	Part No.
----------	-------------	----------

2.4 MECHANISM UNIT (DECK II)

Parts List

1	ASS'Y HOLDER HEAD	RXA1416	41	BRACKET FW	RNE1438
2	FLAME HEAD	RNK1715	42	
3	LEVER HEAD	RNK1716	43	ASS'Y MOTOR(OTHERS)	RXM1052
4	SPRING AZIMUTH	RBK1006		ASS'Y MOTOR	RXM1051
5	ASS'Y ARM ASSIST	RXA1401		(CT - W350R/HB, HBXJ, HEMXJ)	
6	GEAR ARM HEAD	RNK1717	44	WIRE	
7	SPRING CASSETTE	RBK1039	45	BELT MAIN (OTHERS)	REB1159
8	EJECT LOCK	RNK1718		BELT MAIN	REB1162
9	CAP REEL	RNK1719		(CT - W350R/HB, HBXJ, HEMXJ)	
10	ASS'Y PINCH ARM L	RXA1403			
11	CHASSIS HEAD	RNE1437	46	P.C. BOARD	RNP1348
12	ASS'Y PINCH ARM R	RXA1404	47	HOUSING	RKP1397
13	ASS'Y ARM PLAY L	RXA1405	48	EJECT LEVER L	RNK1702
14	GEAR PLAY	RNK1720	49	COLLAR	RNK1704
15	ASS'Y ARM PLAY R	RXA1406	50	WIRE HEAD	RKP1399
16	CHASSIS OS.	RXA1411	61	SPRING	RBH1282
17	ASS'Y SUB REEL L	RXA1407	62	SPRING	RBH1283
18	SOLENOID	RXP1017	63	SPRING	RBH1284
19	WIRE	RDC1006	64	SPRING	RBH1286
20	ARM RVS	RNK1721	65	SPRING	RBH1288
21	GEAR FF	RNK1723	66	SPRING	RBH1290
22	ASS'Y ARM FR	RXA1412	67	SPRING	RBH1285
23	ASS'Y PULLEY FR	RXA1413	68	SPRING	RBH1287
24	BELT FR	REB1158	69	SPRING	RBH1289
25	METAL	RNG1048	70	SPRING	RBH1291
26	ASS'Y FLYWHEEL L (OTHERS)	RXA1409	71	SPRING	RBH1292
	ASS'Y FLYWHEEL L (CT - W350R/HB, HBXJ, HEMXJ)	RXA1414	72	SPRING	RBH1061
			73	SPRING	RBH1060
			74	SPRING	RBH1294
27	METAL	RNG1005	81	SCREW	RBA1023
28	ARM BRAKE	RNK1724	82	SCREW	RBA1027
29	ASS'Y SUB REEL R	RXA1408	83	SCREW	RBA1030
30	ARM TRIGGER	RNK1722	84	SCREW	PCZ20P040FMC
			85	SCREW	RBA1093
31	GEAR CAM	RNK1725	86	SCREW	RBA1094
32	METAL	RNG1049	87	SCREW	RBA1086
33	ASS'Y FLYWHEEL R (OTHERS)	RXA1410	88	SCREW	RBA1095
	ASS'Y FLYWHEEL R (CT - W350R/HB, HBXJ, HEMXJ)	RXA1415	89	GEAR FW L (CT - W350R/HB, HBXJ, HEMXJ)	RNK1732
34	METAL	RNG1004	90	GEAR FW R (CT - W350R/HB, HBXJ, HEMXJ)	RNK1733
35	WIRE (14P)	RDD1217			
36	HOLDER WIRE				
37	P.C. BOARD	RNP1347	101	WASHER	RBF1044
38	SWITCH MODE	RSN1020	102	WASHER	WA16D032D025
39	SWITCH (LEAF)	RSN1019	103	WASHER	WA26D047D013
40	HALL IC.	DN6851A			

Mechanism Unit (Deck II)

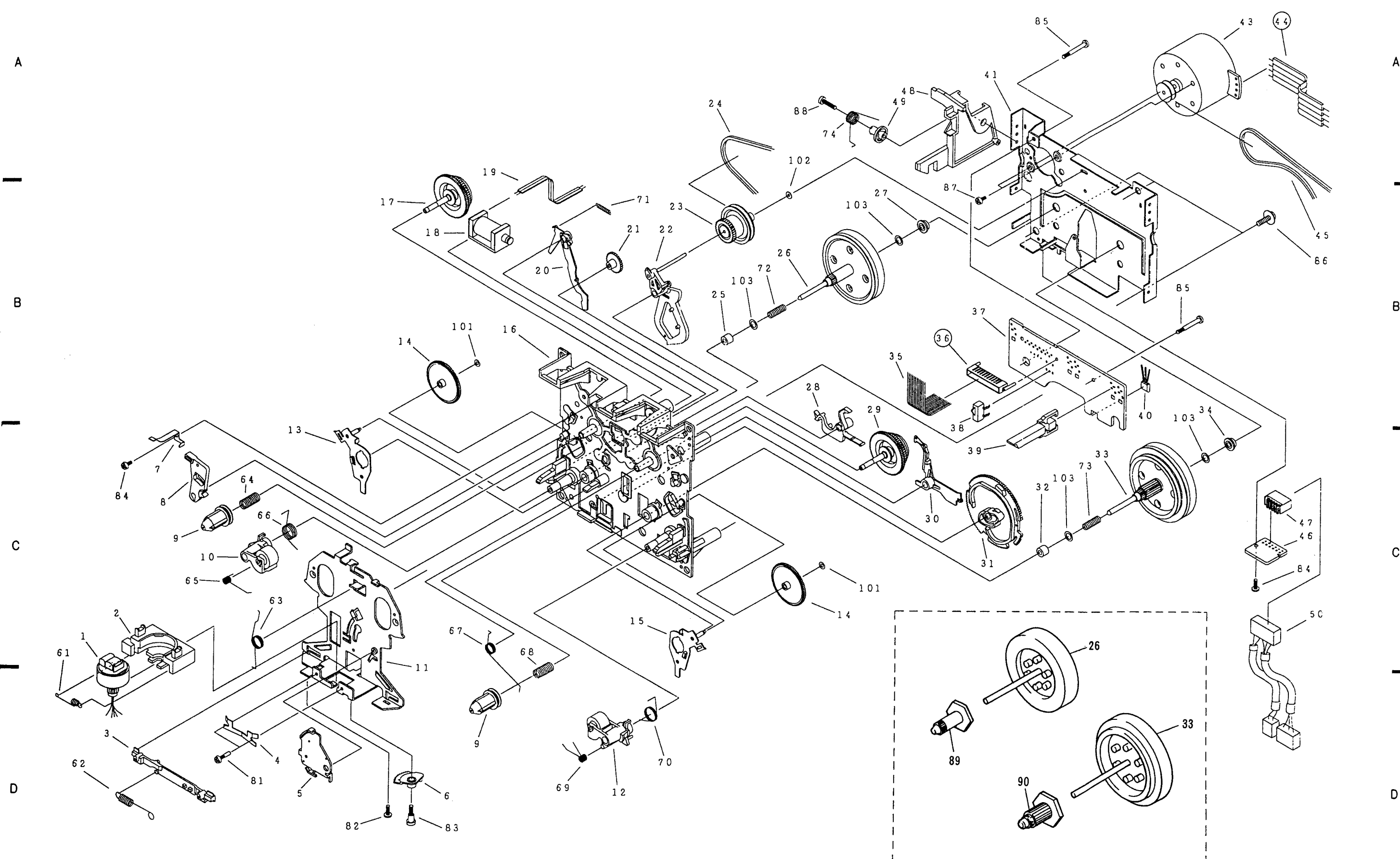

CT-W350R/HB, HBXJ, HEMXJ

3. P.C. BOARDS CONNECTION DIAGRAM

Power Supply Section for SDXJ Type.

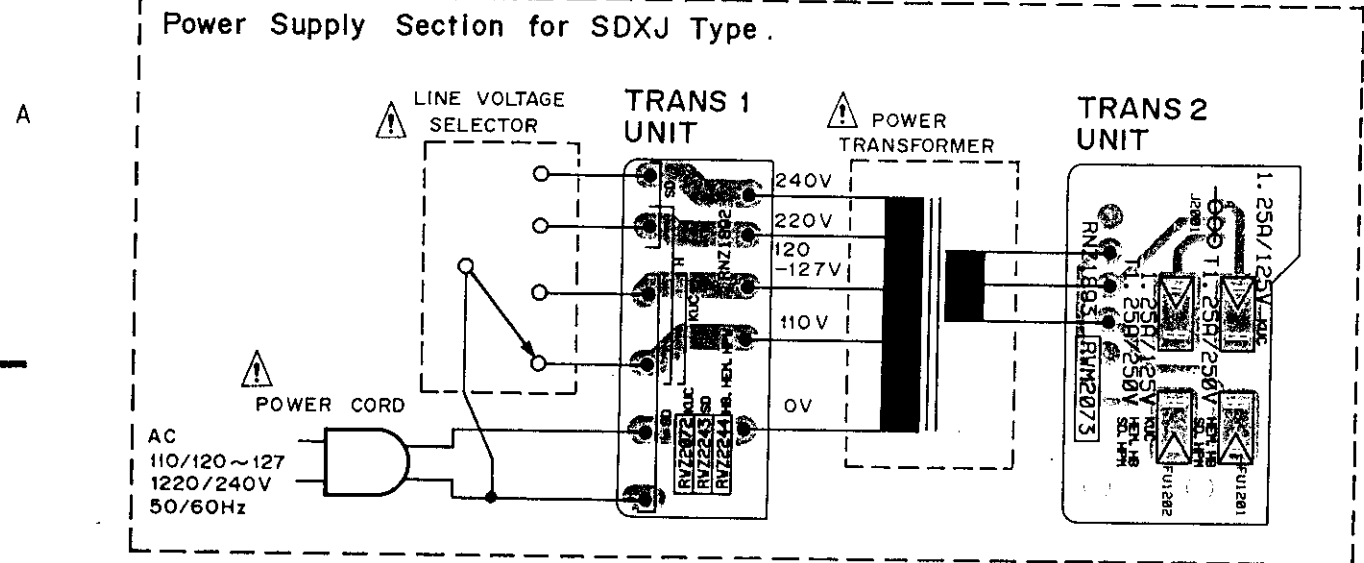

Power Supply Section for HEMXJ, HB, HBXJ and HPWXJ Types.

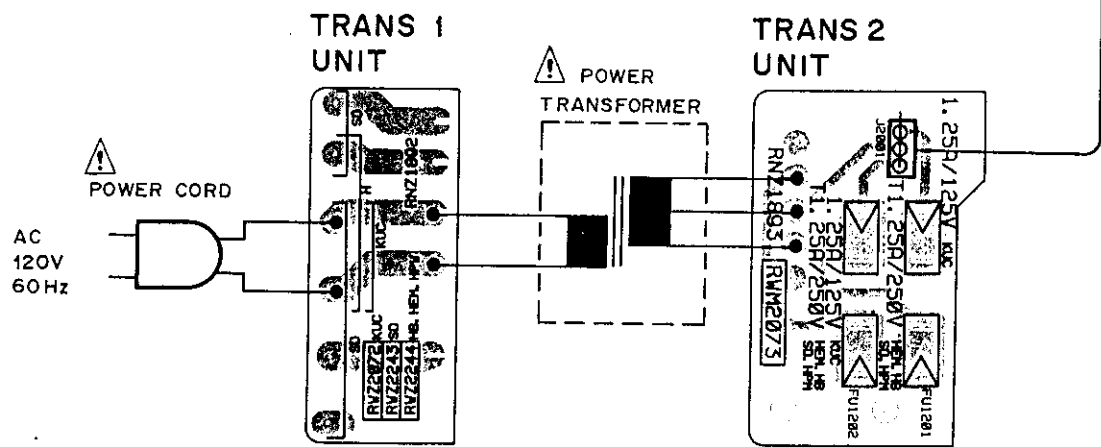
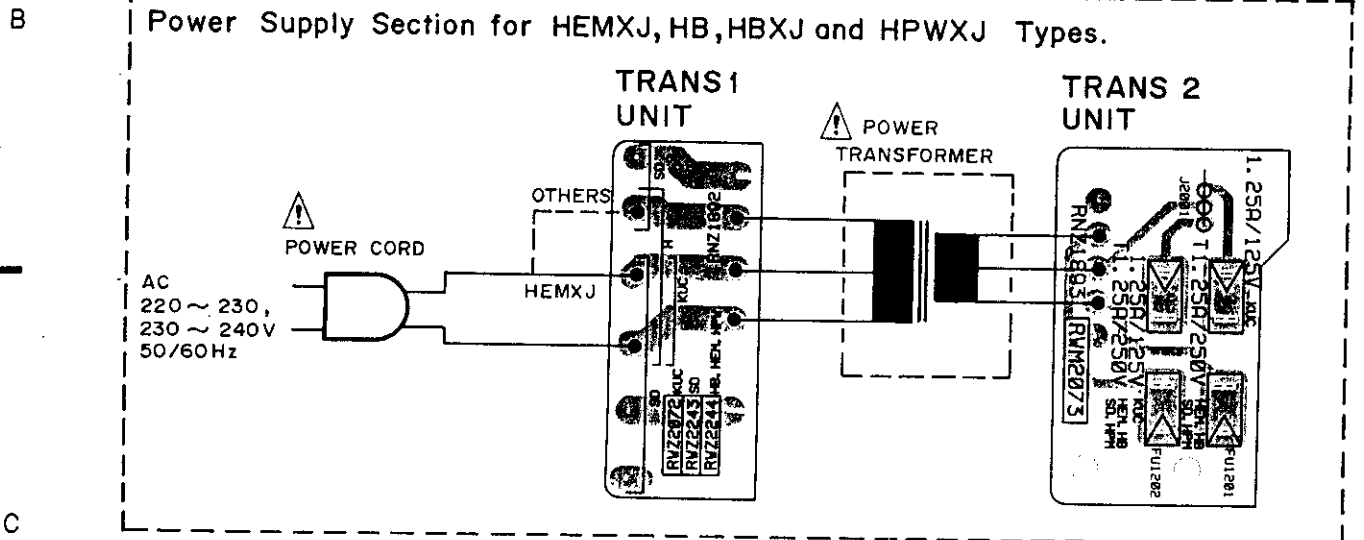

I - MECHA

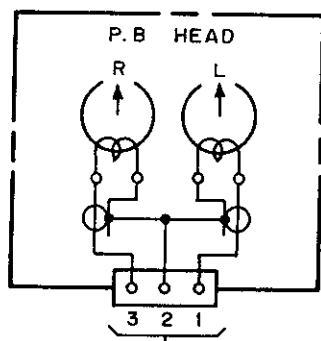

CT-W350R/HEMXJ, HB, HBXJ and CT-W450R ONLY

H. PHONE UNIT

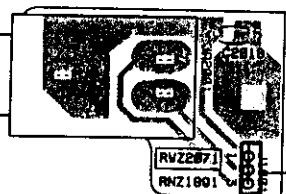

MAIN UNIT

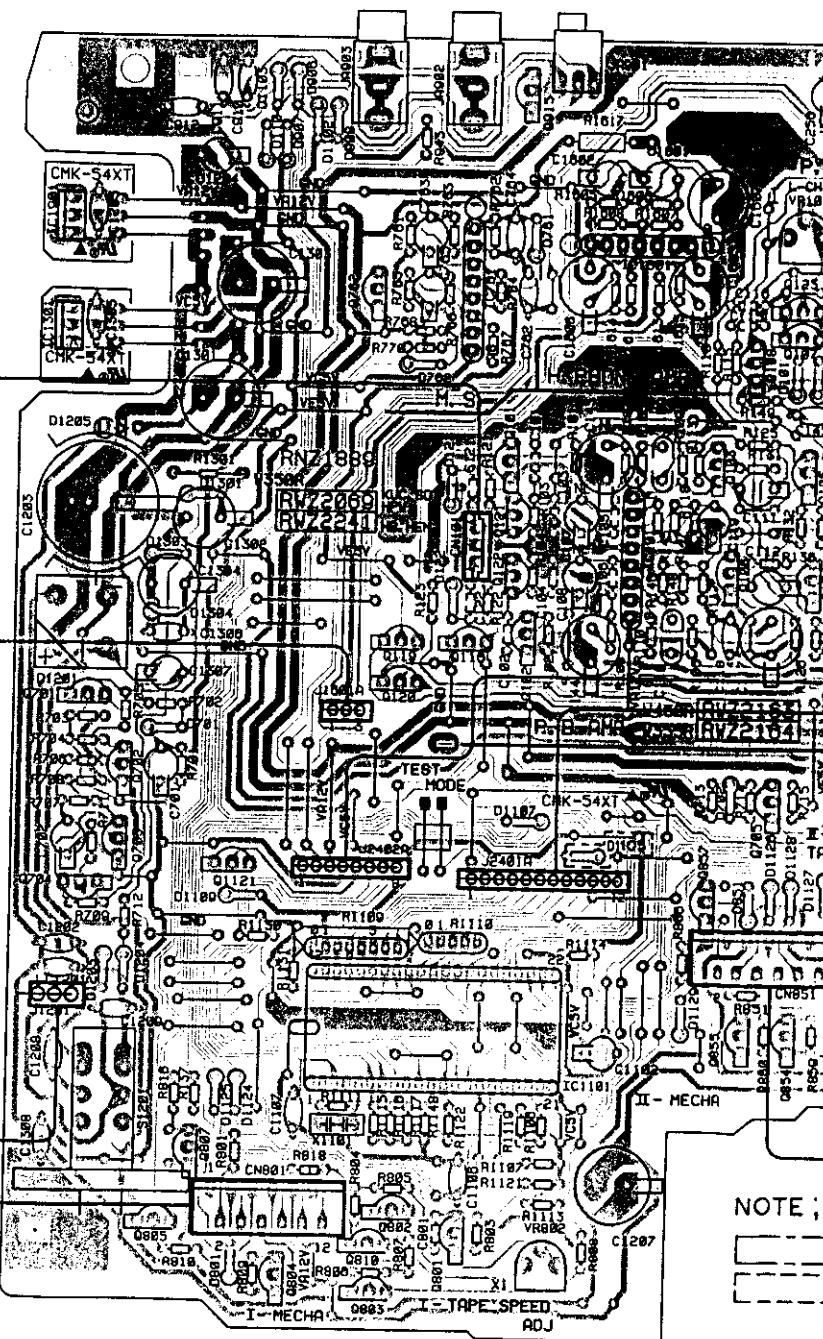

Line Voltage Selection

- Line voltage can be changed with the following steps.
1. Disconnect the AC power cord.
 2. Remove the top cover.
 3. Change the connection of the TRNS 1 UNIT primary pins.
 4. Stick the line voltage label on the rear panel.

Port NO.	Description
AXX-193	220V label
AXX-192	240V label

I - MECHA

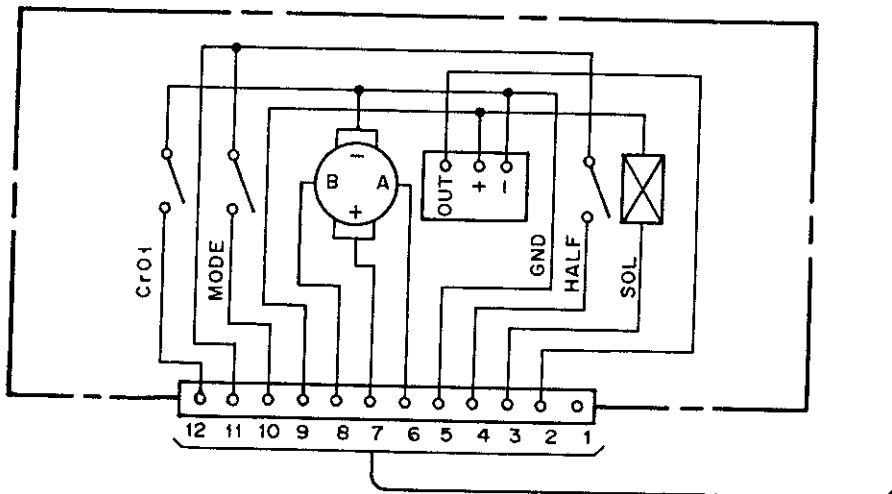

NOTE:

Q701	Q702	Q704	Q703	Q805	Q807	Q762	Q915	Q120	IC761	IC101	IC601	Q101	Q121	Q122	Q119	Q116	Q102	Q120	IC101	Q810	Q802	Q801	Q855	Q854	Q705	Q108	Q103	Q105	Q106	Q104	Q857	Q107	Q109	Q110
------	------	------	------	------	------	------	------	------	-------	-------	-------	------	------	------	------	------	------	------	-------	------	------	------	------	------	------	------	------	------	------	------	------	------	------	------

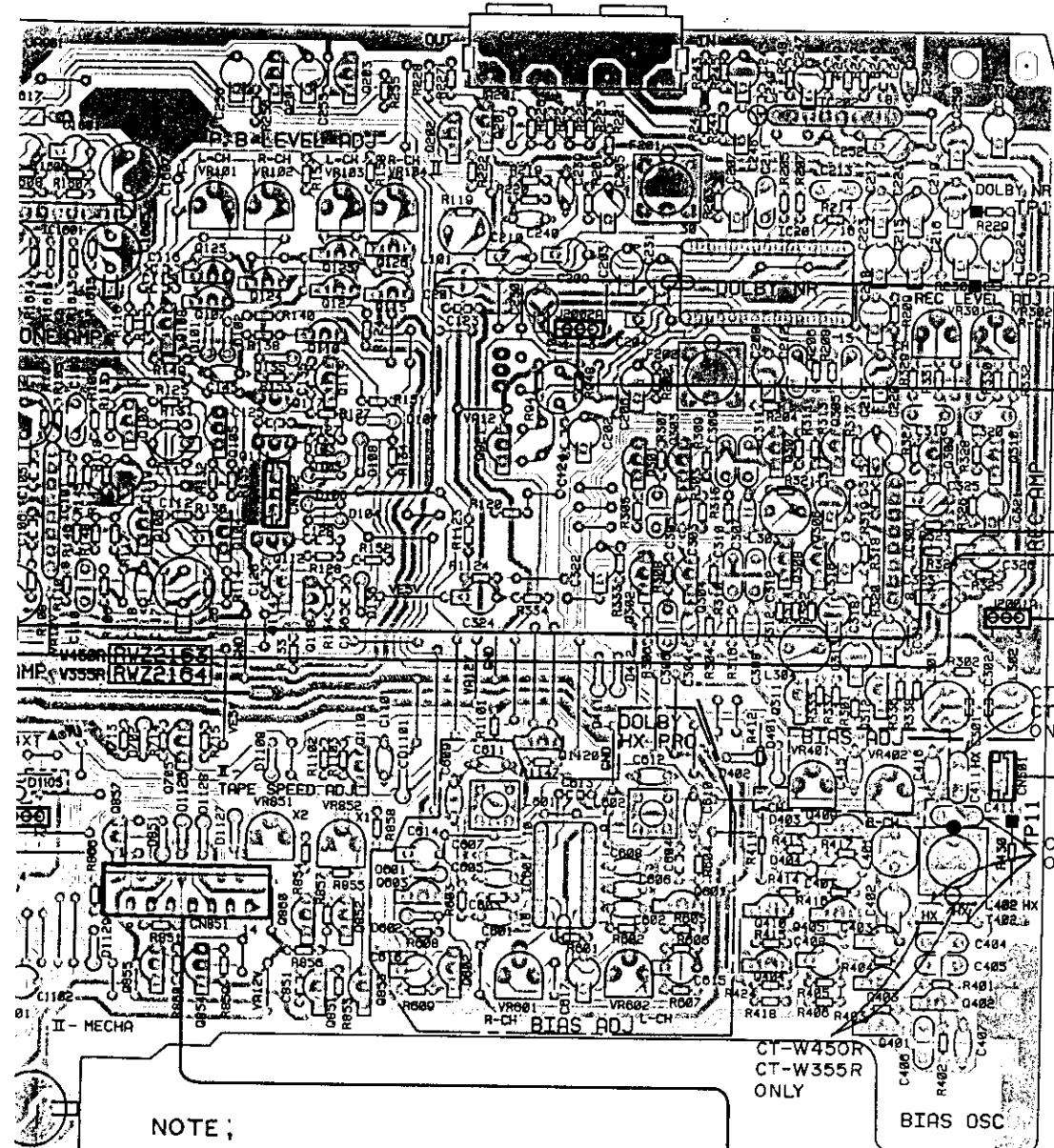

II - MECHA

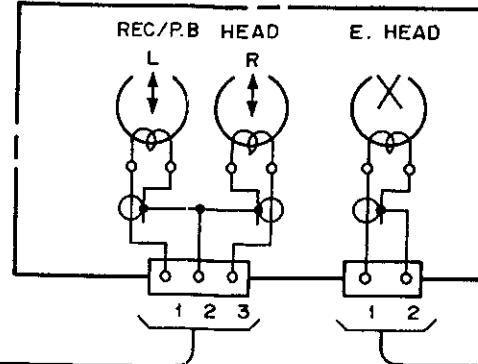

SUB UNIT

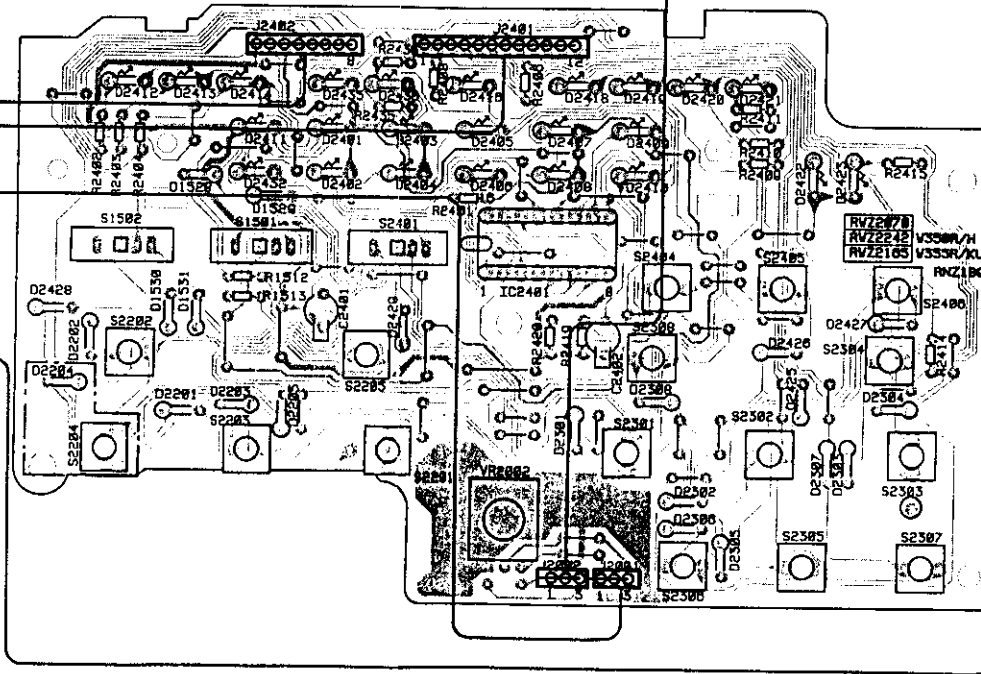

II MECH

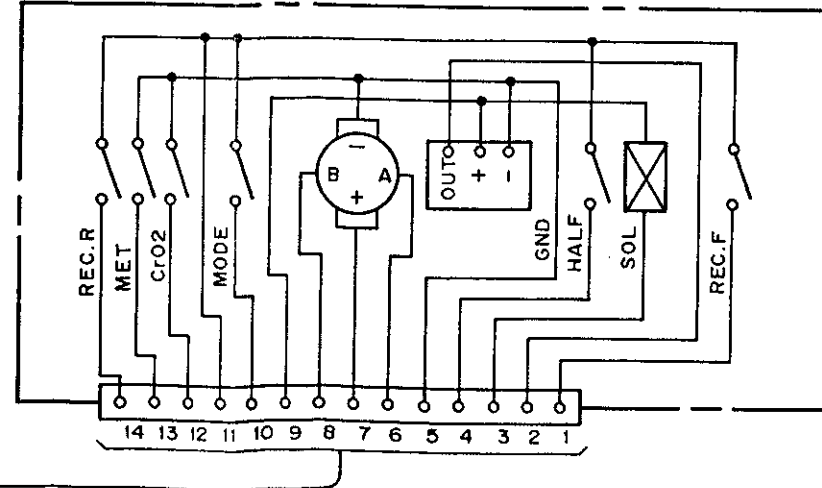

NOTE ;
 [Solid line] ; CT-W450R, CT-W355R ONLY
 [Dashed line] ; CT-W350R ONLY

- VR101 VR102 VR103 VR104
- VR851 VR852 [VR601 VR602] VR301 VR302
- C601 Q204 Q203 Q202 Q201 IC202
- Q123 Q124 Q125 Q126 IC201
- Q107 Q127 Q115
- Q108 Q110
- Q103 Q105 Q117 Q113 Q921 Q301 Q303 Q307 Q305 Q309 Q310
- IC101 Q111 IC301
- Q106 Q104 Q112 Q302 Q304 Q308 Q306
- Q114 Q118
- Q857 Q705 Q1011 Q1120 Q311 Q312
- Q860 Q852 Q603 IC601 Q605 Q410 Q405
- Q855 Q854 Q851 Q853 Q602 Q404 Q403 Q402
- Q401

P.C.B. pattern diagram indication	Corresponding part symbol	Part name
		Transistor
		FET
		Diode
		Zener diode
		LED
		Varactor
		Tact switch
		Inductor
		Coil
		Transformer
		Filter
		Ceramic capacitor
		Mylar capacitor
		Styrol capacitor
		Electrolytic capacitor (Non polarized)
		Electrolytic capacitor (Noiseless)
		Electrolytic capacitor (Polarized)
		Electrolytic capacitor (Polarized)
		Power capacitor
		Semi-fixed resistor
		Resistor array
		Resistor
		Resonator
		Thermistor

1 This P.C.B. connection diagram is viewed from the parts mounted side.
 2 The parts which have been mounted on this board can be replaced with those shown with the corresponding wiring symbols listed in the above Table.
 3 The capacitor terminal marked with shows negative terminal.
 4 The diode marked with shows cathode side.
 5 The transistor terminal marked with shows emitter.

This P.C.B. connection diagram is viewed from the foil side.

15 11 10 e 8 7

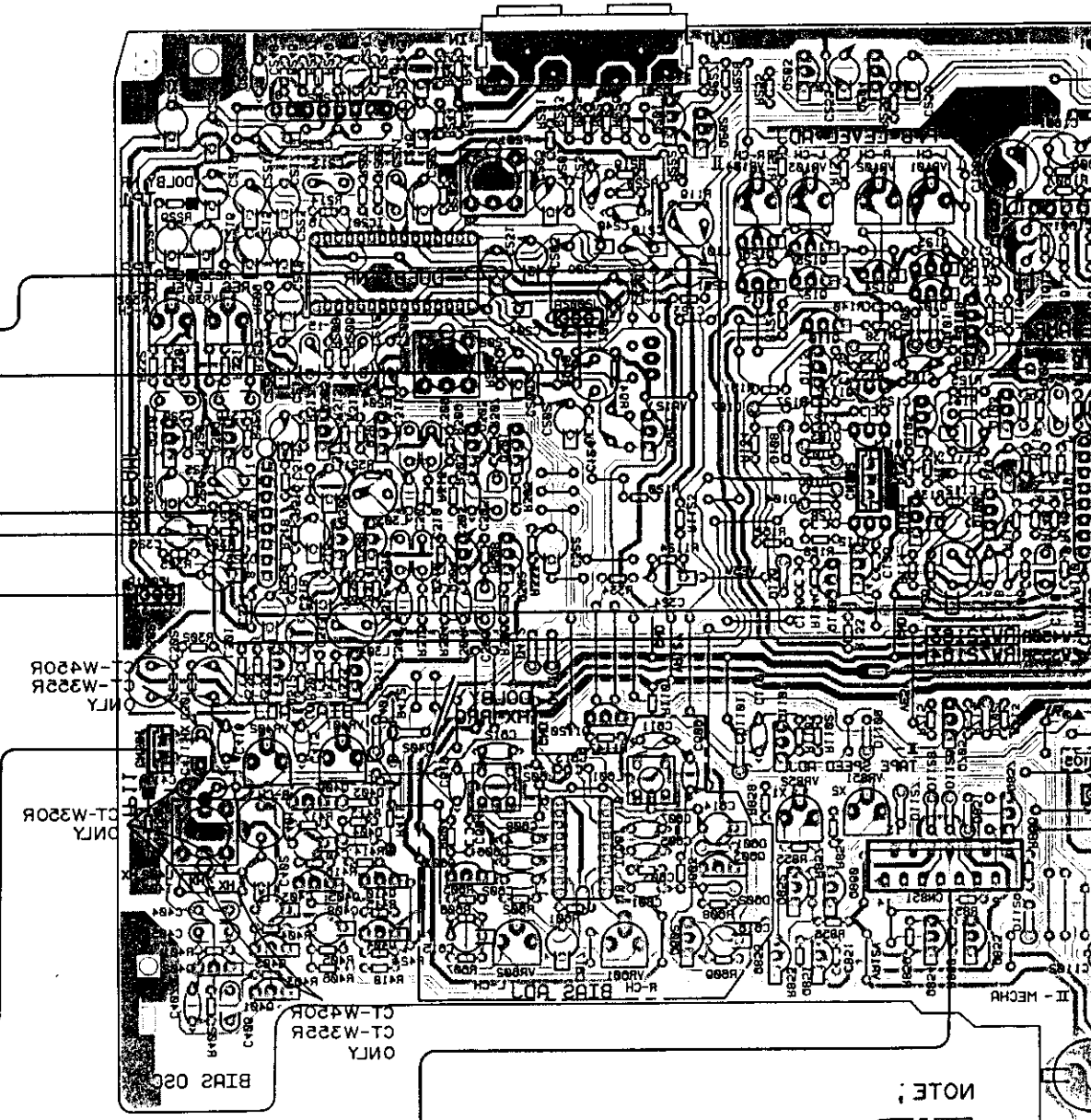
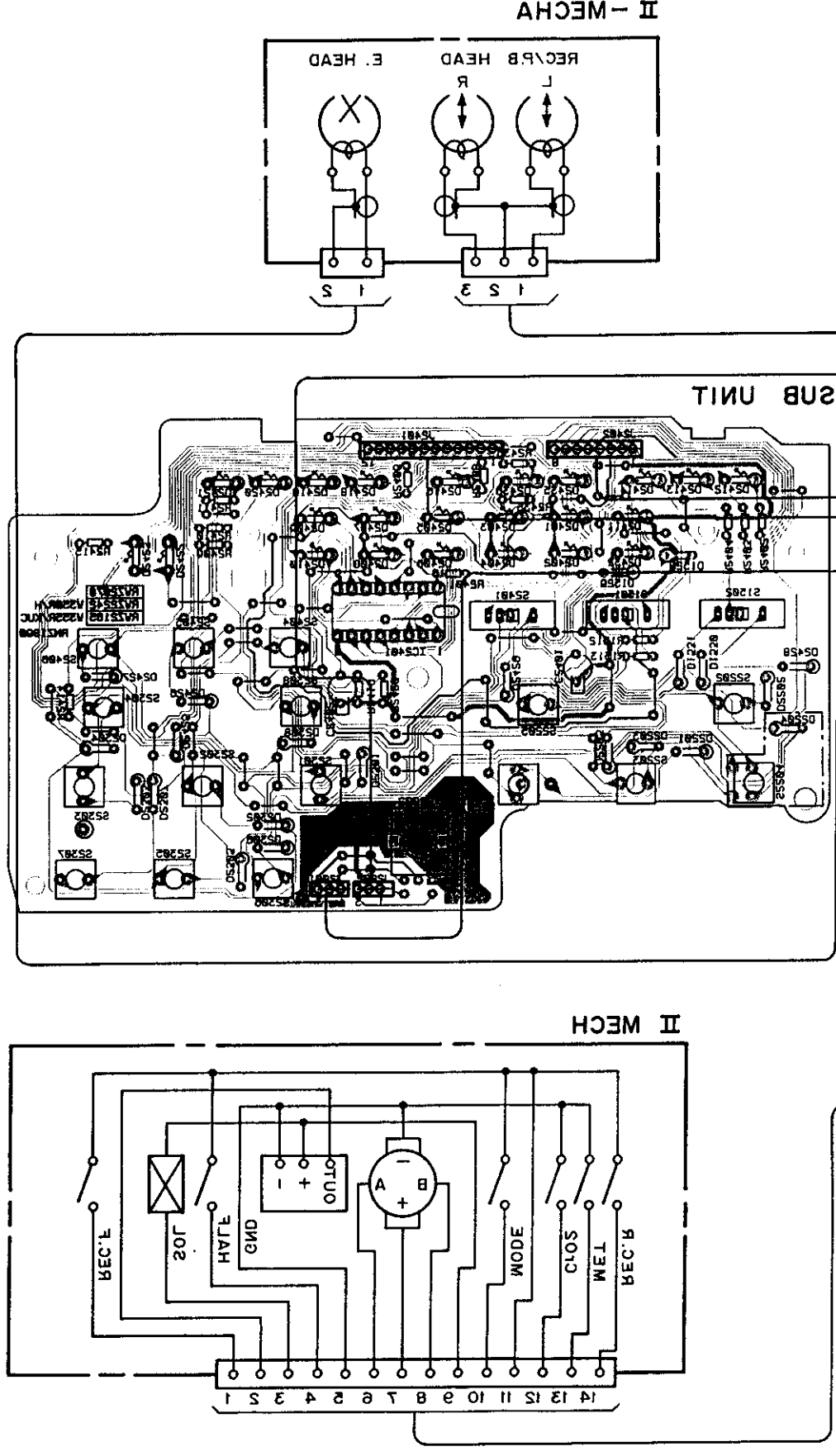

NOTE:

--- : CT-W320R ONLY

- - - - : CT-W450R, CT-W352R ONLY

0401	0404	0403	0402	0405	0406	0407	0408	0409	0410	0411	0412	0413	0414	0415	0416	0417	0418	0419	0420	0421	0422	0423	0424	0425	0426	0427	0428	0429	0430	0431	0432	0433	0434	0435	0436	0437	0438	0439	0440	0441	0442	0443	0444	0445	0446	0447	0448	0449	0450	0451	0452	0453	0454	0455	0456	0457	0458	0459	0460	0461	0462	0463	0464	0465	0466	0467	0468	0469	0470	0471	0472	0473	0474	0475	0476	0477	0478	0479	0480	0481	0482	0483	0484	0485	0486	0487	0488	0489	0490	0491	0492	0493	0494	0495	0496	0497	0498	0499	0500
------	------	------	------	------	------	------	------	------	------	------	------	------	------	------	------	------	------	------	------	------	------	------	------	------	------	------	------	------	------	------	------	------	------	------	------	------	------	------	------	------	------	------	------	------	------	------	------	------	------	------	------	------	------	------	------	------	------	------	------	------	------	------	------	------	------	------	------	------	------	------	------	------	------	------	------	------	------	------	------	------	------	------	------	------	------	------	------	------	------	------	------	------	------	------	------	------	------	------	------

15 11 10 e 8 7

3. P.C. BOARDS CONNECTION DIAGRAM

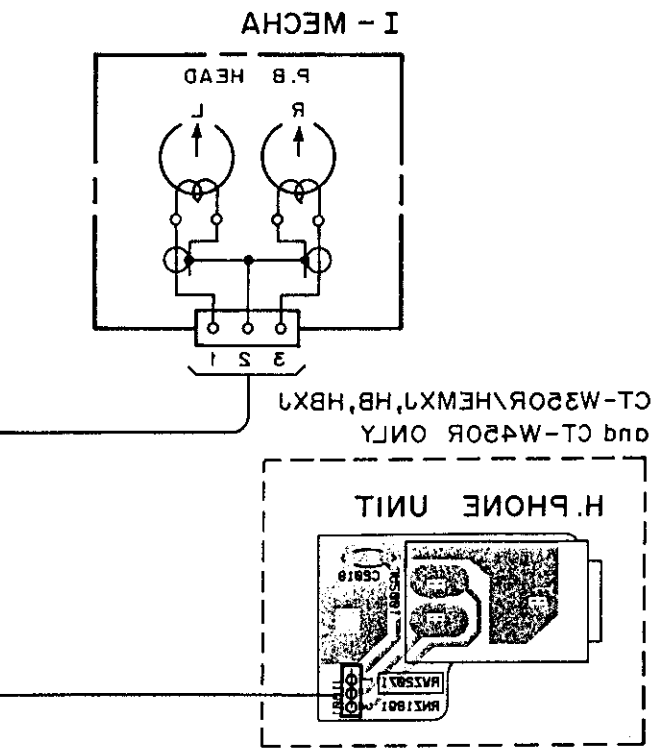
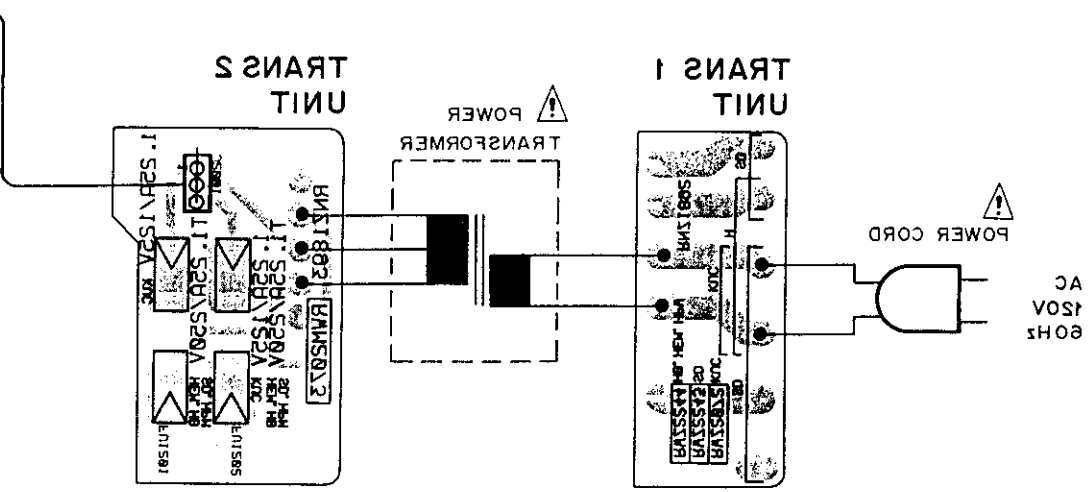
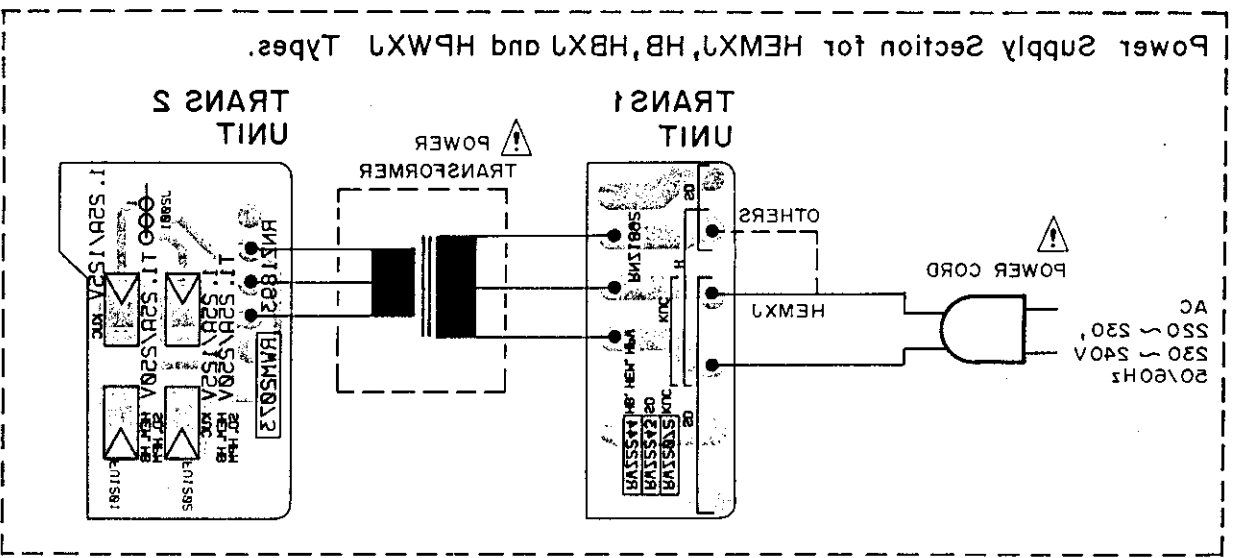
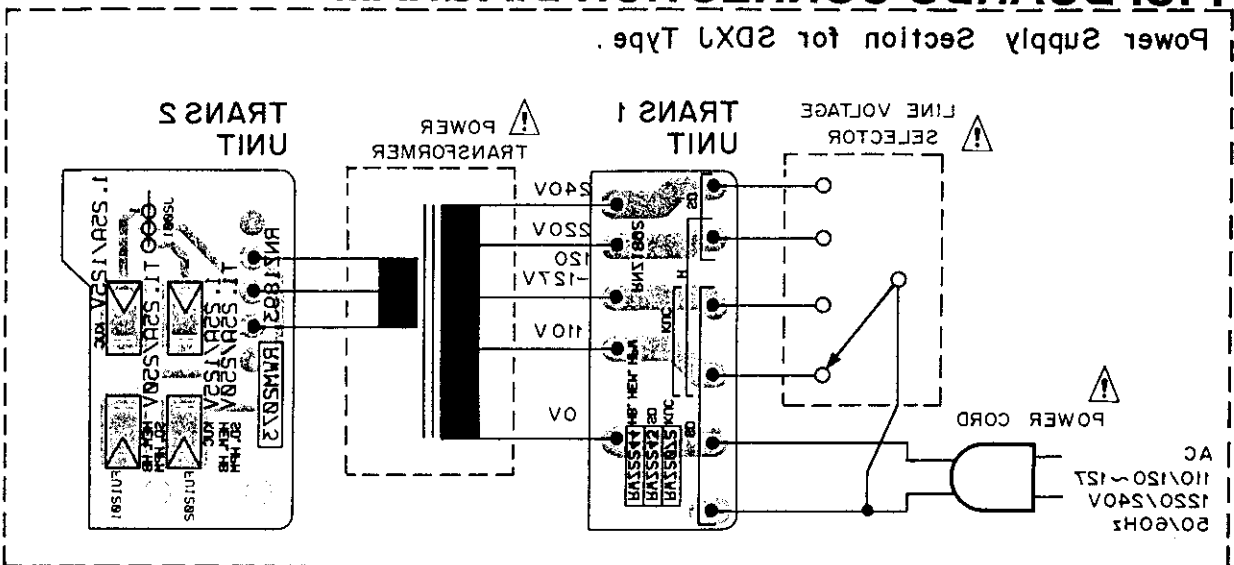

- Line Voltage Selection
1. Disconnect the AC power cord.
 2. Remove the top cover.
 3. Change the connection of the TRNS 1 UNIT primary pins.
 4. Stick the line voltage label on the rear panel.
- Line voltage can be changed with the following steps.

Port NO.	Description
AXX-193	220V Label
AXX-192	240V Label

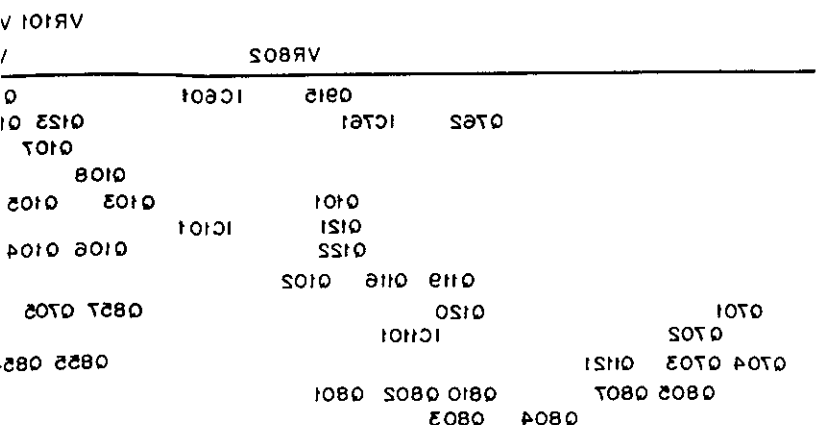
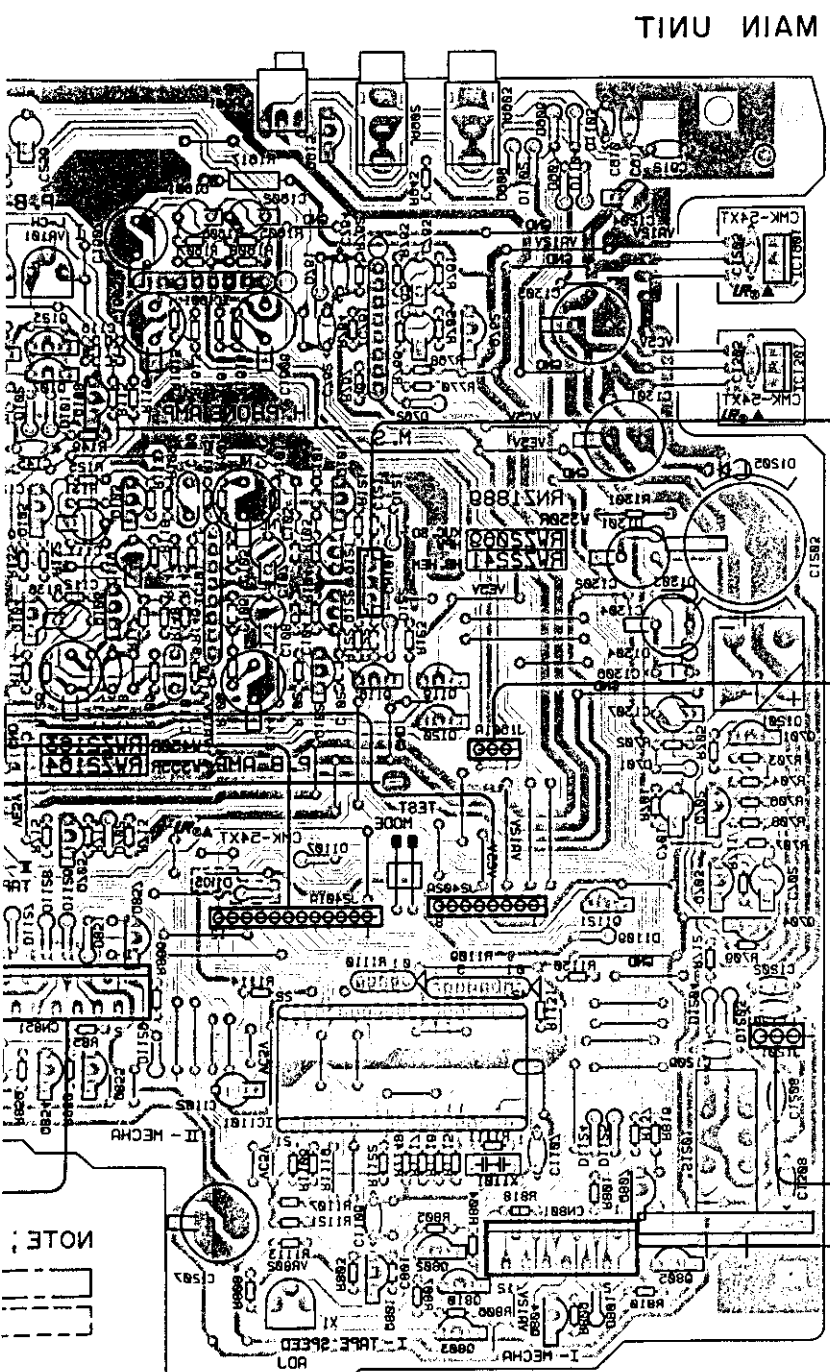
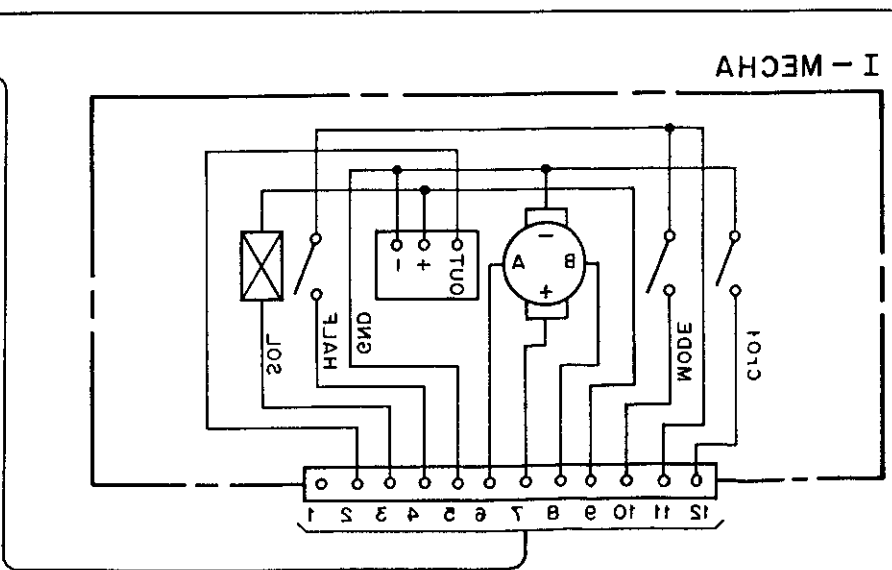

4. SCHEMATIC DIAGRAM

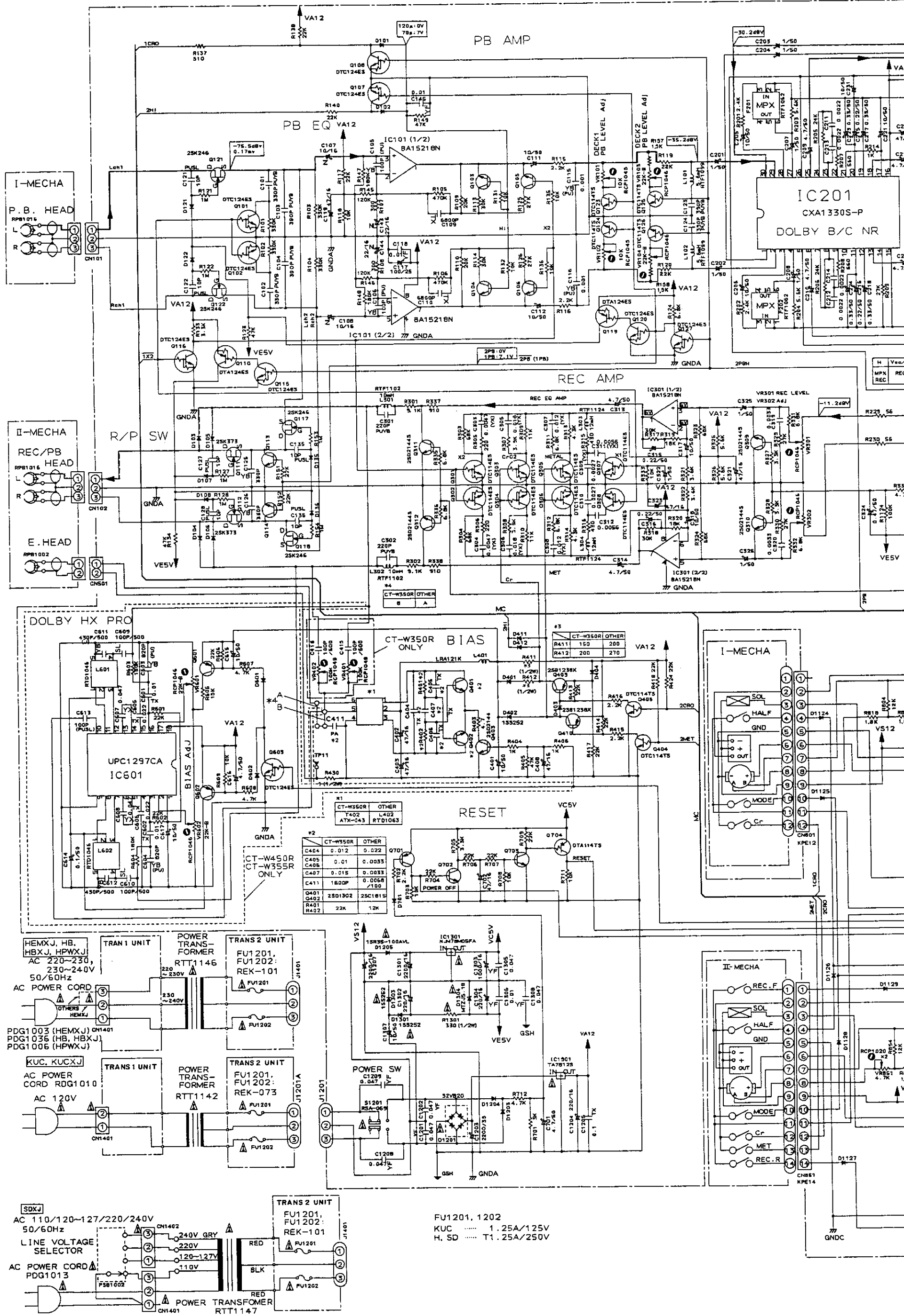

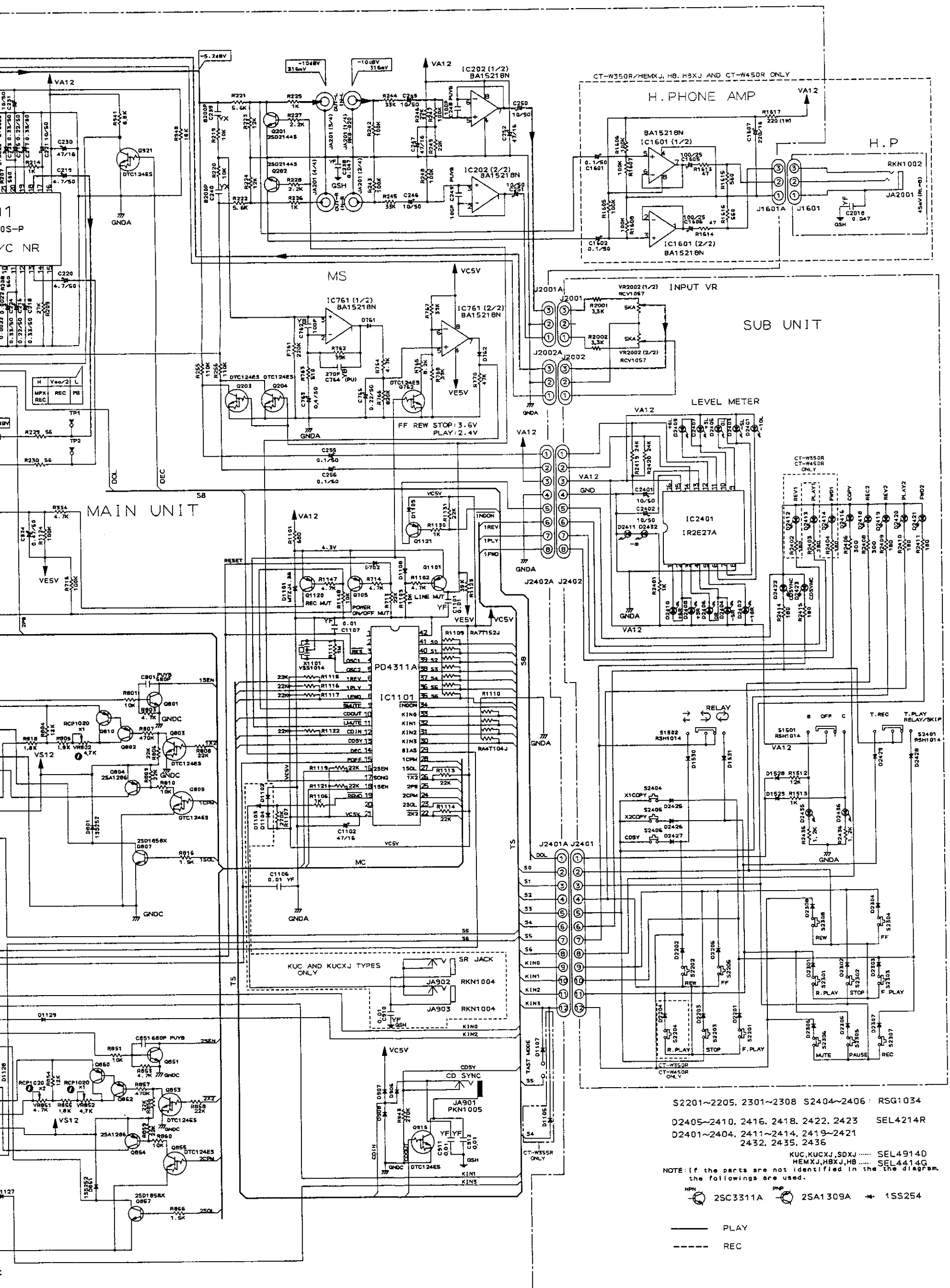

S2201~2205, 2301~2308 S2404~2406: RSG1034
 D2405~2410, 2416, 2418, 2422, 2423 SEL4214R
 D2401~2404, 2411~2414, 2419~2421
 2432, 2435, 2436

KUC, KUCXJ, SDXJ SEL4914D
 HEMXJ, HBXJ, HB SEL4414G

NOTE: If the parts are not identified in the diagram, the followings are used.

- 2SC3311A ○ 2SA1309A * 1SS254
- PLAY
- - - REC

A

B

C

This is the basic schematic diagram, but the actual circuit may vary due to improvements in design.

replacing, be sure to use parts of identical designation. The Δ mark found on some component parts indicates the importance of the safety factor of the part. Therefore, when marked capacitors and resistors have parts numbers.

4. OTHERS :
 \rightarrow : Signal route.
 \odot : Adjusting point.

3. VOLTAGE CURRENT :
 : DC voltage (V) at no input signal.
 \rightarrow mA : DC current at no input signal.

2. CAPACITORS :
 Indicated in capacity (μ F) / voltage (V) unless otherwise noted p.p.f. Indication without voltage is 50V except electrolytic capacitor.

1. RESISTORS :
 Indicated in Ω , 1/6W, $\pm 5\%$ tolerance unless otherwise noted k: k Ω , M: M Ω , (F): $\pm 1\%$, (G): $\pm 2\%$, (K): $\pm 10\%$, (M): $\pm 20\%$ tolerance.

CT-W450R

5. P.C.B's PARTS LIST

NOTES:

- Parts without part number cannot be supplied.
- Parts marked by "⊙" are not always kept in stock. Their delivery time may be longer than usual or they may be unavailable.
- The Δ mark found on some component parts indicates the importance of the safety factor of the part. Therefore, when replacing, be sure to use parts of identical designation.
- When ordering resistors, first convert resistance values into code form as shown in the following examples.

Ex.1 When there are 2 effective digits (any digit apart from 0), such as 560 ohm and 47k ohm (tolerance is shown by J=5%, and K=10%)

560 Ω \rightarrow 56 $\times 10^1 \rightarrow$ 561 RD1/4PS $\begin{matrix} 5 & 6 & 1 \\ \hline & & J \end{matrix}$
 47k Ω \rightarrow 47 $\times 10^3 \rightarrow$ 473 RD1/4PS $\begin{matrix} 4 & 7 & 3 \\ \hline & & J \end{matrix}$
 0.5 Ω \rightarrow 0R5 RN2H $\begin{matrix} 0 & R & 5 \\ \hline & & K \end{matrix}$
 1 Ω \rightarrow 010 RSIP $\begin{matrix} 0 & 1 & 0 \\ \hline & & K \end{matrix}$

Ex.2 When there are 3 effective digits (such as in high precision metal film resistors).

5.62k $\Omega \rightarrow$ 562 $\times 10^1 \rightarrow$ 5621 RN1/4SR $\begin{matrix} 5 & 6 & 2 & 1 \\ \hline & & & F \end{matrix}$

Mark	No.	Description	Part No.	Mark	No.	Description	Part No.
SUB UNIT				H.PHONE UNIT			
SEMICONDUCTORS				CAPACITORS			
	IC2401	LEVEL METER IC	IR2E27A		C2018	CERAMIC CAPACITOR	CKCYF473Z50
	D1528-1531	DIODE	1SS254	OTHERS			
	D2201-2205	DIODE	1SS254		JA2001	JACK	RKN1002
	D2301-2308	DIODE	1SS254	TRANS 1 UNIT			
	D2401-2404	LED	SEL4914D	There is no supply part in this unit.			
	D2405-2410	LED	SEL4214R	TRANS 2 UNIT			
	D2411-2414	LED	SEL4914D	There is no supply part in this unit.			
	D2416	LED	SEL4214R	MAIN UNIT			
	D2418	LED	SEL4214R	SEMICONDUCTORS			
	D2419-2421	LED	SEL4914D		IC101	IC	BA15218N
	D2422, 2423	LED	SEL4214R		IC201	DOLBY B/C IC	CXA1330S
	D2425-2429	DIODE	1SS254		IC202	IC	BA15218N
	D2432	LED	SEL4914D		IC301	IC	BA15218N
	D2435, 2436	LED	SEL4914D		IC601	DOLBY HX PRO IC	UPC1297CA
SWITCHES					IC761	IC	BA15218N
	S1501, 1502	SWITCH	RSH1014		IC1101	CPU	PD4311A
	S2201-2205	SWITCH	RSG1034	Δ	IC1301	REGULATOR IC	NJM78M05FA
	S2301-2308	SWITCH	RSG1034		IC1601	IC	BA15218N
	S2401	SWITCH	RSH1014	Δ	IC1901	REGULATOR IC	TA7812S
	S2404-2406	SWITCH	RSG1034		Q101, 102	TRANSISTOR	DTC124ES
CAPACITORS					Q103-106	TRANSISTOR	2SC3311A
	C2401, 2402	ELECTR. CAPACITOR	CEAS100M50		Q107, 108	TRANSISTOR	DTC124ES
RESISTORS					Q110	TRANSISTOR	DTA124ES
	R1512, 1513	CARBONFILM RESISTOR	RD1/6PM□□□J		Q111, 112	N-FET	2SK373
	R2401-2404	CARBONFILM RESISTOR	RD1/6PM□□□J		Q113, 114	TRANSISTOR	2SC3311A
	R2406	CARBONFILM RESISTOR	RD1/6PM□□□J		Q115, 116	TRANSISTOR	DTC124ES
	R2408-2411	CARBONFILM RESISTOR	RD1/6PM□□□J		Q117, 118	N-FET	2SK246
	R2414, 2415	CARBONFILM RESISTOR	RD1/6PM□□□J		Q119	TRANSISTOR	DTA124ES
	R2001, 2002		RD1/6PM332J		Q120	TRANSISTOR	DTC124ES
	R2419, 2420	CARBONFILM RESISTOR	RD1/6PM□□□J		Q121, 122	N-FET	2SK246
	R2435, 2436	CARBONFILM RESISTOR	RD1/6PM□□□J		Q123-126	DIGITAL TRANSISTOR	DTC114TS
	VR2002	VARIABLE RESISTOR(5K)	RCV1057		Q127	TRANSISTOR	DTC124ES
					Q201, 202	TRANSISTOR	2SD2144S

5. SWITCHES (Underline indicates switch position)

MAIN UNIT

S1201 : POWER ON - OFF

SUB UNIT

S1501 : DOLBY B - OFF - C

S1502 : RELAY $\overline{B} - \overline{C} - \overline{\phi}$

S2201 : F. PLAY

S2202 : REW

S2203 : STOP

S2204 : R. PLAY

S2205 : F.F

S2301 : R. PLAY

S2302 : STOP

S2303 : F. PLAY

S2304 : F.F

S2305 : PAUSE

S2306 : MUTE

S2307 : REC

S2308 : REW

S2401 : T. REC - T. PLAY RELAY/SKIP

S2404 : X1 COPY

S2405 : X2 COPY

S2406 : CDSY

Mark	No.	Description	Part No.	Mark	No.	Description	Part No.
	Q203, 204	TRANSISTOR	DTC124ES	Δ	D1304	ZENER DIODE	MTZJ5. 1B
	Q301-308	TRANSISTOR	DTC114ES	SWITCHES			
	Q309-312	TRANSISTOR	2SD2144S	Δ	S1201	SWITCH	RSA-069
	Q401, 402	TRANSISTOR	2SC1815	COILS/TRANSFORMERS			
	Q403	TRANSISTOR	2SD2144S		L101, 102	COIL	RTF1099
	Q404, 405	DIGITAL TRANSISTOR	DTC114TS		L301, 302	COIL	RTF1102
	Q409, 410	TRANSISTOR	2SB1238X		L303, 304	COIL	RTF1124
	Q601, 602	TRANSISTOR	2SA1309A		L401	RADIAL INDUCTOR	LRA121K
	Q603	TRANSISTOR	DTC124ES		L402	COIL	RTD1063
	Q701	TRANSISTOR	2SA1309A		L601, 602	COIL	RTD1046
	Q702, 703	TRANSISTOR	2SC3311A		F201, 202	FILTER	RTF1062
	Q704	TRANSISTOR	DTA114TS	CAPACITORS			
	Q705	TRANSISTOR	2SA1309A		C101, 102	AXIAL CAPACITOR	CKPUYB331K50
	Q762	TRANSISTOR	DTC124ES		C103, 104	AXIAL CAPACITOR	CKPUYB391K50
	Q801	TRANSISTOR	2SC3311A		C105, 106	AXIAL CAPACITOR	CKPUYB101K50
	Q802	TRANSISTOR	2SA1309A		C107, 108	ELECTR. CAPACITOR	CEANL100M16
	Q803	TRANSISTOR	DTC124ES		C109, 110	AUDIO FILM CAPACITOR	CFTXA682J50
	Q804	TRANSISTOR	2SA1286		C111, 112	ELECTR. CAPACITOR	CEAS100M50
	Q805	TRANSISTOR	DTC124ES		C115, 116	CERAMIC CAPACITOR	CKPUYB102K50
	Q807	TRANSISTOR	2SD1858X		C117	ELECTR. CAPACITOR	CEAS101M25
	Q810	TRANSISTOR	2SA1309A		C118	CERAMIC CAPACITOR	CKCYF103Z50
	Q851	TRANSISTOR	2SC3311A		C119	ELECTR. CAPACITOR	CEAS470M16
	Q852	TRANSISTOR	2SA1309A		C121, 122	AXIAL CERAMIC C.	CCPUSL100J50
	Q853	TRANSISTOR	DTC124ES		C123, 124	AXIAL CAPACITOR	CKPUYB391K50
	Q854	TRANSISTOR	2SA1286		C125, 126	CERAMIC CAPACITOR	CCCSL331J50
	Q855	TRANSISTOR	DTC124ES		C127, 128	AXIAL CERAMIC C.	CCPUSL100J50
	Q857	TRANSISTOR	2SD1858X		C135, 136	AXIAL CERAMIC C.	CCPUSL100J50
	Q860	TRANSISTOR	2SA1309A		C143, 144	ELECTR. CAPACITOR	CEANL220M16
	Q915	TRANSISTOR	DTC124ES		C145	CERAMIC CAPACITOR	CKCYF103Z50
	Q921	TRANSISTOR	DTC124ES		C201-204	ELECTR. CAPACITOR	CEAS010M50
	Q1101	TRANSISTOR	2SA1309A		C205, 206	ELECTR. CAPACITOR	CEAS100M50
	Q1120, 1121	TRANSISTOR	2SA1309A		C207, 208	ELECTR. CAPACITOR	CEAS010M50
	D101-108	DIODE	1SS254		C209, 210	ELECTR. CAPACITOR	CEAS4R7M50
	D121, 122	DIODE	1SS254		C211-214	AUDIO FILM CAPACITOR	CFTXA222J50
	D135, 136	DIODE	1SS254		C215, 216	ELECTR. CAPACITOR	CEASR22M50
	D401	DIODE	1SS254		C217, 218	ELECTR. CAPACITOR	CEASR33M50
	D402	DIODE	1SS252		C219, 220	ELECTR. CAPACITOR	CEAS4R7M50
	D403, 404	DIODE	1SS254		C221	ELECTR. CAPACITOR	CEAS100M50
	D411, 412	DIODE	1SS254		C223, 224	ELECTR. CAPACITOR	CEASR33M50
	D601, 602	DIODE	1SS254		C230	ELECTR. CAPACITOR	CEAS470M16
	D701, 702	DIODE	1SS254		C231	ELECTR. CAPACITOR	CEAS100M50
	D761, 762	DIODE	1SS254		C238	CERAMIC CAPACITOR	CKCYF473Z50
	D801	DIODE	1SS252		C239, 240	CERAMIC CAPACITOR	CGCYX822K25
	D851	DIODE	1SS252		C245, 246	ELECTR. CAPACITOR	CEAS100M50
	D906-908	DIODE	1SS254		C247	ELECTR. CAPACITOR	CEAS470M16
	D1101	ZENER DIODE	MTZJ4. 3B		C248, 249	AXIAL CAPACITOR	CKPUYB101K50
	D1102-1104	DIODE	1SS254		C250, 251	ELECTR. CAPACITOR	CEAS100M50
	D1107-1109	DIODE	1SS254		C252	ELECTR. CAPACITOR	CEAS470M16
	D1124-1129	DIODE	1SS254		C255, 256	ELECTR. CAPACITOR	CEASR10M50
Δ	D1201		S2VB20		C301, 302	AXIAL CAPACITOR	CKPUYB221K50
	D1203, 1204	DIODE	1SS254		C303, 304	CERAMIC CAPACITOR	CGCYX472K25
Δ	D1205	DIODE	1SR35-100AVL		C305, 306	CERAMIC CAPACITOR	CGCYX183K25
Δ	D1301	DIODE	1SS252		C307, 308	CERAMIC CAPACITOR	CGCYX123K25
Δ	D1303	DIODE	1SS252				

Mark	No.	Description	Part No.	Mark	No.	Description	Part No.
C309,	310	CERAMIC CAPACITOR	CGCYX272K25	C1601,	1602	ELECTR. CAPACITOR	CEASR10M50
C311,	312	CERAMIC CAPACITOR	CGCYX472K25	C1605,	1606	ELECTR. CAPACITOR	CEAS101M25
C313,	314	ELECTR. CAPACITOR	CEAS4R7M50	C1607	ELECTR. CAPACITOR	CEAS221M16	
C315,	316	ELECTR. CAPACITOR	CEASR22M50				
C317,	318	ELECTR. CAPACITOR	CEAS100M50				
C319,	320	AUDIO FILM CAPACITOR	CFTXA332J50				
C321	ELECTR. CAPACITOR	CEAS470M16					
C322	ELECTR. CAPACITOR	CEAS010M50					
C323	ELECTR. CAPACITOR	CEAS470M16					
C324	ELECTR. CAPACITOR	CEASR47M50					
C325,	326	ELECTR. CAPACITOR	CEAS010M50				
C401	ELECTR. CAPACITOR	CEAS100M50					
C402,	403	ELECTR. CAPACITOR	CEAS470M16				
C404	AUDIO FILM CAPACITOR	CFTXA223J50					
C405-407	AUDIO FILM CAPACITOR	CFTXA332J50					
C408	ELECTR. CAPACITOR	CEAS470M16					
C411	CAPACITOR	CQPA682J100					
C601,	602	AUDIO FILM CAPACITOR	CFTXA103J50				
C603,	604	AXIAL CAPACITOR	CKPUYB821K50				
C605,	606	AUDIO FILM CAPACITOR	CFTXA223J50				
C607,	608	CERAMIC CAPACITOR	CGCYX473K25				
C609,	610	CERAMIC CAPACITOR	CCCSL101K500				
C611,	612	CERAMIC CAPACITOR	RCCG1005				
C613	AXIAL CERAMIC C.	CCPUSL100J50					
C614	ELECTR. CAPACITOR	CEASR10M50					
C615	ELECTR. CAPACITOR	CEAS100M50					
C616	ELECTR. CAPACITOR	CEAS4R7M50					
C617	ELECTR. CAPACITOR	CEAS100M50					
C701	ELECTR. CAPACITOR	CEAS4R7M50					
C702	ELECTR. CAPACITOR	CEAS470M16					
C762	AXIAL CAPACITOR	CKPUYB101K50					
C763	ELECTR. CAPACITOR	CEASR47M50					
C764	AXIAL CAPACITOR	CKPUYB271K50					
C765	ELECTR. CAPACITOR	CEASR22M50					
C801	AXIAL CAPACITOR	CKPUYB681K50					
C851	AXIAL CAPACITOR	CKPUYB681K50					
C910-912	CERAMIC CAPACITOR	CKCYF103Z50					
C1101	CERAMIC CAPACITOR	CKCYF103Z50					
C1102	ELECTR. CAPACITOR	CEAS470M16					
C1106,	1107	CERAMIC CAPACITOR	CKCYF103Z50				
C1201,	1202	CERAMIC CAPACITOR	CKCYF473Z50				
C1203	ELECTR. CAPACITOR	CEAS222M35					
C1204	ELECTR. CAPACITOR	CEAS221M16					
C1205	AUDIO FILM CAPACITOR	CFTXA104J50					
C1207	ELECTR. CAPACITOR	CEAS222M16					
C1208,	1209	CERAMIC CAPACITOR	CKCYF473Z50				
C1301	ELECTR. CAPACITOR	CEAS222M16					
C1302	ELECTR. CAPACITOR	CEAS221M16					
C1303	ELECTR. CAPACITOR	CEAS102M16					
C1304	ELECTR. CAPACITOR	CEAS221M16					
C1305	CERAMIC CAPACITOR	CKCYF473Z50					
C1306	CERAMIC CAPACITOR	CKCYF103Z50					
C1307	ELECTR. CAPACITOR	CEAS100M50					
C1308	CERAMIC CAPACITOR	CKCYF473Z50					
R101-110	CARBONFILM RESISTOR	RD1/6PM□□□J					
R113-128	CARBONFILM RESISTOR	RD1/6PM□□□J					
R131-136	CARBONFILM RESISTOR	RD1/6PM□□□J					
R138	CARBONFILM RESISTOR	RD1/6PM□□□J					
R140	CARBONFILM RESISTOR	RD1/6PM□□□J					
R157,	158	RD1/6PM152J					
R145-149	CARBONFILM RESISTOR	RD1/6PM□□□J					
R151-154	CARBONFILM RESISTOR	RD1/6PM□□□J					
R201-209	CARBONFILM RESISTOR	RD1/6PM□□□J					
R214	CARBONFILM RESISTOR	RD1/6PM□□□J					
R229,	230(56Ω)	RCN1029					
R219-228	CARBONFILM RESISTOR	RD1/6PM□□□J					
R242-249	CARBONFILM RESISTOR	RD1/6PM□□□J					
R255,	256	CARBONFILM RESISTOR	RD1/6PM□□□J				
R301-338	CARBONFILM RESISTOR	RD1/6PM□□□J					
R401-406	CARBONFILM RESISTOR	RD1/6PM□□□J					
R411	CARBONFILM RESISTOR	RD1/2LF□□□J					
R412	CARBONFILM RESISTOR	RD1/2LF□□□J					
R413-418	CARBONFILM RESISTOR	RD1/6PM□□□J					
R424	CARBONFILM RESISTOR	RD1/6PM□□□J					
R430	CARBONFILM RESISTOR	RD1/2LF□□□J					
R601-609	CARBONFILM RESISTOR	RD1/6PM□□□J					
R701-709	CARBONFILM RESISTOR	RD1/6PM□□□J					
R711-715	CARBONFILM RESISTOR	RD1/6PM□□□J					
R761-768	CARBONFILM RESISTOR	RD1/6PM□□□J					
R770	CARBONFILM RESISTOR	RD1/6PM□□□J					
R801	CARBONFILM RESISTOR	RD1/6PM□□□J					
R803	CARBONFILM RESISTOR	RD1/6PM□□□J					
R804,	805	RN1/6PQ□□□□F					
R806-810	CARBONFILM RESISTOR	RD1/6PM□□□J					
R816	CARBONFILM RESISTOR	RD1/6PM□□□J					
R818	CARBONFILM RESISTOR	RN1/6PQ□□□□F					
R851	CARBONFILM RESISTOR	RD1/6PM□□□J					
R853	CARBONFILM RESISTOR	RD1/6PM□□□J					
R854,	855	RN1/6PQ□□□□F					
R856-860	CARBONFILM RESISTOR	RD1/6PM□□□J					
R866	CARBONFILM RESISTOR	RD1/6PM□□□J					
R941	CARBONFILM RESISTOR	RD1/6PM□□□J					
R943	CARBONFILM RESISTOR	RD1/6PM□□□J					
R948	CARBONFILM RESISTOR	RD1/6PM□□□J					
R1101-1103	CARBONFILM RESISTOR	RD1/6PM□□□J					
R1106,	1107	CARBONFILM RESISTOR	RD1/6PM□□□J				
R1109	RESISTOR ARRAY(1.5K)	RA7T152J					
R1110	RESISTOR ARRAY(100K)	RA4T104J					
R1111	CARBONFILM RESISTOR	RD1/6PM□□□J					
R1113-1117	CARBONFILM RESISTOR	RD1/6PM□□□J					
R1119	CARBONFILM RESISTOR	RD1/6PM□□□J					
R1121-1124	CARBONFILM RESISTOR	RD1/6PM□□□J					
R1130,	1131	CARBONFILM RESISTOR	RD1/6PM□□□J				
R1147,	1148	CARBONFILM RESISTOR	RD1/6PM□□□J				

Mark	No.	Description	Part No.
△	R1301	CARBONFILM RESISTOR	RD1/2LF□□□J
	R1605-1608	CARBONFILM RESISTOR	RD1/6PM□□□J
	R1613-1616	CARBONFILM RESISTOR	RD1/6PM□□□J
	R1617		RS1LF221J
	VR101, 102	VR(10K)	RCP1045
	VR301, 302	VR(22K)	RCP1046
	VR601, 602	VR(22K)	RCP1046
	VR802	VR(4. 7K)	RCP1020
	VR103, 104	VR(22K)	RCP1046
	VR851, 852	VR(4. 7K)	RCP1020
OTHERS			
	CN801	CONNECTOR(12P)	KPE12
	CN851	CONNECTOR(14P)	KPE14
	JA201	JACK	RKB-020
	JA901	JACK	PKN1005
	JA902, 903	JACK	RKN1004
	X1101	CERAMIC RESONATOR	VSS1014

6. ADJUSTMENTS

6.1 MECHANICAL ADJUSTMENT

These adjustments must be performed in the TEST MODE.

- Entering the TEST MODE
Set the Reverse Mode Switch to \leftarrow , and short the TEST MODE jumper wire.
- Releasing the TEST MODE
Press the STOP keys of DECKS I and II simultaneously.

1. Tape Speed Adjustment and Check						
No.	Deck	Mode	Test tape	Adjusting points	Specifications/Ratings (playback frequency)	Remarks
1	I	Normal speed PLAY	STD-301 (3 kHz)	Play back for 1 minute and then press the FF key. *1		
2		Double speed PLAY		check	6000 Hz \pm 600 Hz	
3		Normal speed PLAY		Press the FF key after checking.		
4	Double speed PLAY	Play back for 1 minute and then press the FF key. *1				
5	II	Normal speed PLAY		VR851	Within \pm 10Hz of step 2 (deck I) check value.	
6		Double speed PLAY		Press the FF key after checking.		
7	I	Normal speed PLAY		VR802	3000 Hz \pm 5 Hz	
8	II	Normal speed PLAY		VR852	Within \pm 5 Hz of step 7 (deck I) adjustment value.	

*1: If the FF key is pressed during PLAY, double speed mode is selected.

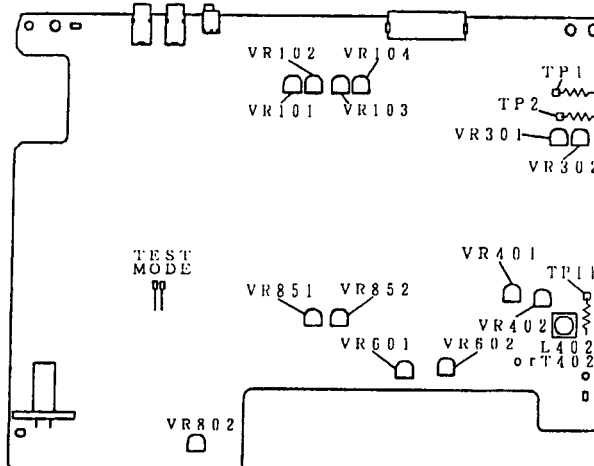

Fig. 6-1 Adjusting points

• Door damping check and adjustment

1. Attach the door spring at position (b) according to fig. 6-2. and stand the front panel assembly straight up as shown in fig. 6-3.
2. Open the doors of DECK I and DECK II simultaneously, and when one of the doors is fully open, confirm that the difference between the two doors is within 15 mm.
3. If the specification described in steps 1 and 2 above is not satisfied, change the door spring position as follows and adjust.
 - When the door of DECK I opens slower than the one of DECK II: Change the DECK II door spring to position (a).
 - When the door of DECK I opens faster than the one of DECK II: Change the DECK I door spring to position (a).

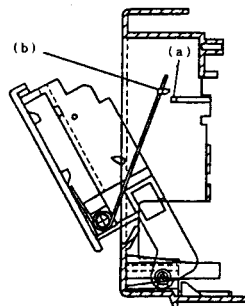

Fig. 6-2

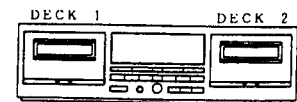

Fig. 6-3

6.2 ELECTRICAL ADJUSTMENTS

Adjustment Conditions

1. The mechanical adjustments must be completed first.
2. The head must be cleaned and demagnetized.
3. Turn power on allow the deck to warm up for at least a few minutes before commencing any electrical adjustments.
4. The reference signal is 0dBv=1Vrms.
5. Connect a 50 kΩ (or between 47k to 52 kΩ) load resistance to the OUTPUT terminals.
6. Unless otherwise specified, the switches listed below are left in the positions indicated.

DOLBY NR : OFF
 TAPE SELECTOR : NORM

Test Tapes

- STD-331B : Playback adjustments
 (See Fig. 6-4)
- STD-630 : NORMAL blank tape
- STD-620 : CrO₂ blank tape
- STD-610 : METAL blank tape

List of Adjustments

Playback sections

1. Head azimuth adjustment.
2. Playback level adjustment.

Recording sections

1. Bias oscillator adjustment.
2. Recording bias adjustment.
3. Recording level adjustment.
4. Level meter check.

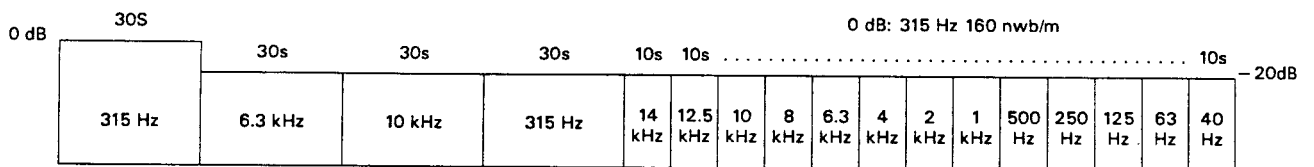
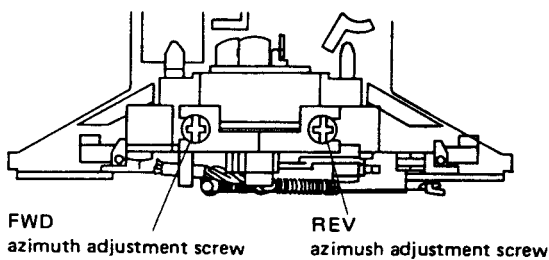

Fig. 6-4 Constants of the test tape STD-331B

CT-W450R, CT-W355R(Deck II), CT-W350R



CT-W355R(Deck I)

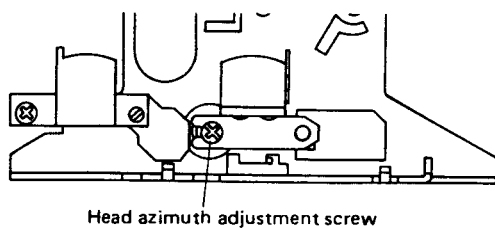
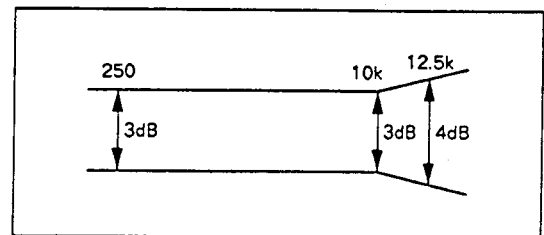

Fig. 6-5 Head azimuth adjustment

PLAY BACK



RECORDING

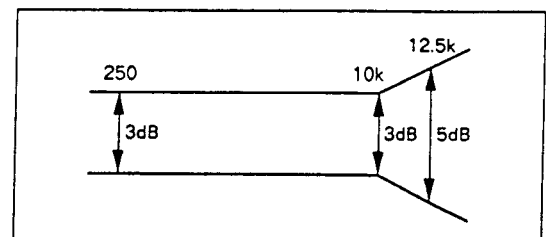

Fig. 6-6 Frequency response zone

PLAYBACK SECTION

1. Head Azimuth Adjustment

• Turn VR101, 102 (Deck I) or VR103, 104 (Deck II) to mechanical center positions.

No.	Mode	Input signal & test tape	Adjustment location	Measuring location	Adjustment value	Remarks
1.	PLAY	Play the 10 kHz/− 20 dB section of STD-331B test tape.	Head azimuth adjustment screw. (See Fig. 6-5)	LINE OUT	Maximum playback signal level.	
2.	STOP	Lock the screw with screw lock after completing adjustment.				

2. Playback level Adjustment

• This adjustment determines the DOLBY NR level, and must be performed with great care.

No.	Mode	Input signal & test tape	Adjustment location	Measuring location	Adjustment value	Remarks
1.	PLAY	Play the 315 Hz/0 dB section of the STD-331B test tape.	Deck I VR101 (Lch) VR102 (Rch) Deck II VR103 (Lch) VR104 (Rch)	TP. 1 (Lch) TP. 2 (Rch)	− 10.7 dBv	

RECORDING SECTION

NOTE: *1: Others *2: CT-W350R

1. Bias Oscillator Adjustment

No.	Mode	Input signal & test tape	Adjustment location	Measuring location	Adjustment value	Remarks
1.	REC	Load the STD-610 test tape with no input signal.	Deck II L402 *1 T402 *2	TP. 11	Maximum output (maximum AC voltage)	

2. Recording Bias Adjustment

• After the adjustment, caution should be exercised so as not to become under bias by checking the distortion rate.

No.	Mode	Input signal & test tape	Adjustment location	Measuring location	Adjustment value	Remarks
1.	STOP	Set the TAPE SELECTOR switch to the NORM position.				
2.	REC	Record the 315 Hz and 6.3 kHz signals at − 20 dBv input level and playback.	Deck II VR601 (Lch) *1 VR602 (Rch) VR401 (Lch) *2 VR402 (Rch)	LINE OUT	Repeatedly record, playback and adjust so that the playback level of 6.3 kHz signal becomes + 0.5 dB ± 0.5 dB when compared with the 315 Hz signal.	

3. Recording Level Adjustment

No.	Mode	Input signal & test tape	Adjustment location	Measuring location	Adjustment value	Remarks
1.	STOP	Set the TAPE SELECTOR switch to the NORM position.				
2.	REC PAUSE	Apply a 315 Hz/0 dBv signal to the line input terminals, load the STD-630 test tape.	Rec Level control volume	TP. 1 (Lch) TP. 2 (Rch)	− 11.2 dBv	
3.	STOP	Set the DOLBY NR switch to the ON position. (DOLBY B)				
4.	REC/ PLAY	Record the above signal onto the STD-630 test tape, and playback.	Deck II VR301 (Lch) VR302 (Rch)	TP. 1 (Lch) TP. 2 (Rch)	Repeatedly record, playback and adjust so that the playback signal level becomes − 11.2 dB.	
5.	STOP	Set the TAPE SELECTOR switch to the CrO ₂ position.				
6.	REC/ PLAY	Record the above signal onto the STD-620 test tape, and playback.	Check	TP. 1 (Lch) TP. 2 (Rch)	− 11.2 dBv ± 1.5 dB	
7.	STOP	Set the TAPE SELECTOR switch to the METAL position.				
8.	REC/ PLAY	Record the above signal onto the STD-610 test tape, and playback.	Check	TP. 1 (Lch) TP. 2 (Rch)	− 11.2 dBv ± 1.5 dB	

4. Level Meter Check

No.	Mode	Input signal & test tape	Adjustment location	Measuring location	Adjustment value	Remarks
1.	REC PAUSE	Apply a 315 Hz/− 10 dBv (316 mV) signal to the Line Input terminals.	Rec Level control volume	TP. 1 (Lch) TP. 2 (Rch)	Check that the level meters "0 dB" light up within − 11.2 dBv ± 2 dB of the signal output level.	

7. FOR CT-W450R/KUCXJ, CT-W355R/KUC, KUCXJ, CT-W350R/KUC, KUCXJ, HEMXJ, HB, HBXJ, HPWXJ AND SDXJ TYPES

CONTRAST OF MISCELLANEOUS PARTS

NOTES:

- Parts without part number cannot be supplied.
- The Δ mark found on some component parts indicates the importance of the safety factor of the part. Therefore, when replacing, be sure to use parts of identical designation.
- Parts marked by "⊙" are not always kept in stock. Their delivery time may be longer than usual or they may be unavailable.

The CT-W450R/KUCXJ, CT-W355R/KUC, KUCXJ, CT-W350R/KUC, KUCXJ, HEMXJ, HB, HBXJ, HPWXJ and SDXJ types are the same as the CT-W450R/KUC type with the exception of the following sections.

Mark	Symbol & Description	Part No.										
		CT-W450R/ KUC type	CT-W450R/ KUCXJ type	CT-W355R/ KUC type	CT-W355R/ KUCXJ type	CT-W350R/ KUC type	CT-W350R/ KUCXJ type	CT-W350R/ HEMXJ type	CT-W350R/ HB type	CT-W350R/ HBXJ type	CT-W350R/ HPWXJ type	CT-W350R/ SDXJ type
	Main unit	Non supply	Non supply	Non supply	Non supply	Non supply	Non supply	Non supply	Non supply	Non supply	Non supply	Non supply
	Sub unit	Non supply	Non supply	Non supply	Non supply	Non supply	Non supply	Non supply	Non supply	Non supply	Non supply	Non supply
	H.Phone unit	Non supply	Non supply	Non supply	Non supply	Non supply
Δ	Trans 1 unit	Non supply	Non supply	Non supply	Non supply	Non supply	Non supply	Non supply	Non supply	Non supply	Non supply	Non supply
	Strain relife	CM-22	CM-22	CM-22	CM-22	CM-22	CM-22	CM-22B	CM-22B	CM-22B	CM-22B	CM-22B
Δ	AC Power cord	RDG1010	RDG1010	RDG1010	RDG1010	RDG1010	RDG1010	PDG1003	PDG1036	PDG1036	PDG1006	PDG1013
Δ	Fuse (1.25A)	REK-073	REK-073	REK-073	REK-073	REK-073	REK-073
Δ	Fuse (1.25A)	REK-101	REK-101	REK-101	REK-101	REK-101
Δ	Power transformer (AC120V)	RTT1142	RTT1142	RTT1142	RTT1142	RTT1142	RTT1142
Δ	Power transformer (AC220-230/230-240V)	RTT1146	RTT1146	RTT1146	RTT1146
Δ	Power transformer (AC110/120-127/220/240V)	RTT1147
Δ	Voltage selector	PSB1002
	Operation knob	RAC1561	RAC1561	RAC1563	RAC1563	RAC1561	RAC1561	RAC1561	RAC1561	RAC1561	RAC1561	RAC1561
	Door pocket (L)	RAH1751	RAH1751	RAH1792	RAH1792	RAH1751	RAH1751	RAH1751	RAH1751	RAH1751	RAH1751	RAH1751
	Door pocket (R)	RAH1789	RAH1789	RAH1790	RAH1790	RAH1750	RAH1750	RAH1750	RAH1750	RAH1750	RAH1750	RAH1750
	Shield plate	Non supply	Non supply	Non supply	Non supply	Non supply	Non supply	Non supply	Non supply	Non supply
	Meter panel	RAH1753	RAH1753	RAH1777	RAH1777	RAH1753	RAH1753	RAH1753	RAH1753	RAH1753	RAH1753	RAH1753
	Leg ass'y	REC-369	REC-369	REC-369	REC-369	REC-369	REC-369	REC-369	REC-369
	Front panel ass'y	RXX1347	RXX1347	RXX1348	RXX1348	RXX1335	RXX1335	RXX1349	RXX1349	RXX1349	RXX1335	RXX1335
	Packing case	RHG1228	RHG1259	RHG1229	RHG1261	RHG1217	RHG1260	RHG1264	RHG1232	RHG1264	RHG1264	RHG1264
	Sheet	RHX-034	RHX-034	RHX-034	RHX-034
	Mirror mat	Z23-007	Z23-007	Z23-007	Z23-007	Z23-007	Z23-007	Z23-007
	Operating instructions (English)	RRB1077	RRB1086	RRB1077	RRB1086	RRB1074	RRB1087	RRB1074	RRB1087	RRB1087	RRB1087
	Operating instructions (English, French, German, Italian, Dutch, Swedish, Spanish, Portuguese)	RRE1043
	Operating instructions (Spanish)	RRD1086
	Stopper	VEC1061	VEC1061	VEC1061
	Insulator	VNK1095	VNK1095	VNK1095
	Mechanism unit (Deck I) *1	Non supply	Non supply	Non supply	Non supply	Non supply	Non supply	Non supply	Non supply	Non supply	Non supply	Non supply
	Mechanism unit (Deck II) *1	Non supply	Non supply	Non supply	Non supply	Non supply	Non supply	Non supply	Non supply	Non supply	Non supply	Non supply

*1: As to Mechanism unit, refer to pages from 6 to 14.

MAIN UNIT

The main units (for CT-W355R/KUC, KUCXJ, CT-W350R/KUC, KUCXJ, HPWXJ, HB, HBXJ, HEMXJ and SDXJ types) are the same as the main units (for CT-W450R/KUC and KUCXJ types) with the exception of the following sections.

Mark	Symbol & Description	Part No.				Remarks
		CT-W450R/ KUC and KUCXJ types	CT-W355R/ KUC and KUCXJ types	CT-W350R/ KUC, KUCXJ, HPWXJ and SDXJ types	CT-W350R/ HB, HBXJ and HEMXJ types	
IC1601		BA15218N	BA15218N	
IC601		UPC1297CA	UPC1297CA	
Q401, Q402		2SC1815	2SC1815	2SD1302	2SD1302	
Q601, Q602		2SA1309A	2SA1309A	
Q603		DTC124ES	DTC124ES	
D1105		1SS254	
D601, D602		1SS254	1SS254	
C1601, C1602		CEASR10M50	CEASR10M50	
C1605, C1606		CEAS101M25	CEAS101M25	
C1607		CEAS221M16	CEAS221M16	
C404		CFTXA223J50	CFTXA223J50	CFTXA123J50	CFTXA123J50	
C405, C406		CFTXA332J50	CFTXA332J50	CFTXA103J50	CFTXA103J50	
C407		CFTXA332J50	CFTXA332J50	CFTXA153J50	CFTXA153J50	
C411		CQPA682J100	CQPA682J100	CQPA162J100	CQPA162J100	
C415, C416		CCCSL101K500	CCCSL101K500	
C601, C602		CFTXA103J50	CFTXA103J50	
C603, C604		CKPUYB821K50	CKPUYB821K50	
C605, C606		CFTXA223J50	CFTXA223J50	
C607, C608		CGCYX473K25	CGCYX473K25	
C609, C610		CCCSL101K500	CCCSL101K500	
C611, C612		RCG1005	RCG1005	
C613		CCPUSL100J50	CCPUSL100J50	
C614		CEASR10M50	CEASR10M50	
C615, C617		CEAS100M50	CEAS100M50	
C616		CEAS4R7M50	CEAS4R7M50	
L402		RTD1063	RTD1063	
L601, L602		RTD1046	RTD1046	
R1605-R1608		RD1/6PM104J	RD1/6PM104J	
R1613, R1614		RD1/6PM470J	RD1/6PM470J	
R1615, R1616		RD1/6PM561J	RD1/6PM561J	
R1617		RS1LF221J	RS1LF221J	
R401, R402		RD1/6PM123J	RD1/6PM123J	RD1/6PM223J	RD1/6PM223J	
R411		RD1/2LF201J	RD1/2LF201J	RD1/2LF151J	RD1/2LM151J	
R412		RD1/2LF271J	RD1/2LF271J	RD1/2LF201J	RD1/2LM201J	
R601, R602, R606		RD1/6PM223J	RD1/6PM223J	
R603, R604		RD1/6PM184J	RD1/6PM184J	
R605		RD1/6PM153J	RD1/6PM153J	
R607, R608		RD1/6PM472J	RD1/6PM472J	
R609		RD1/6PM103J	RD1/6PM103J	
VR401, VR402		RCP1049	RCP1049	
VR601, VR602		RCP1046	RCP1046	
T402		ATX-043	ATX-043	

SUB UNIT

The sub units (for CT-W355R/KUC, KUCXJ, CT-W350R/HB, HBXJ and HEMXJ types) are the same as the sub units (for CT-W450R/KUC, KUCXJ, CT-W350R/KUC, KUCXJ, HPWXJ and SDXJ types) with the exception of the following sections.

Mark	Symbol & Description	Part No.			Remarks
		CT-W450R/ KUC, KUCXJ, CT-W350R/KUC, KUCXJ, HPWXJ and SDXJ types	CT-W355R/ KUC and KUCXJ types	CT-W350R/ HB, HBXJ and HEMXJ	
	D2412, D2414 D2401-D2404, D2411, D2413, D2419-D2421, D2432, D2435, D2436	SEL4914D SEL4914D SEL4914D	SEL4414G SEL4414G	
	D2204 R2402, R2404 S2204	1SS254 RD1/6PM181J RSG1034	1SS254 RD1/6PM181J RSG1034	

8. SPECIFICATIONS

CT-W450R AND CT-W355R

System 4-track, 2-channel stereo
 Heads "Hard permalloy" recording/playback head × 1
 "Hard permalloy" playback head × 1
 "Ferrite" erasing head × 1
 Motors DC servo motor × 2
 Wow and Flutter No more than 0.10% (WRMS, JIS)
 Fast Winding Time Approx. 120 seconds (C-60 tape)
 Frequency Response (at -20 dB recording level)
 Metal Tape 30 to 16,500 Hz
 Chrome Tape 30 to 16,000 Hz
 Normal Tape 30 to 16,000 Hz
 Signal-to-Noise Ratio
 Dolby NR off More than 56 dB
 Noise Reduction Effect
 Dolby B-type NR ON More than 10 dB (at 5 kHz)
 Dolby C-type NR ON More than 19 dB (at 5 kHz)
 Harmonic Distortion No more than 0.8% (at 0 dB)
 Input (Sensitivity)
 LINE (INPUT) 63 mV (Input impedance 56 kΩ)
 Output (Reference level)
 LINE (OUTPUT) 316 mV (Output impedance 4.5 kΩ)
 Headphones
 (CT-W450R only) 0.25 mW (Output impedance 8 Ω)

Miscellaneous

Power requirements AC 120V, 60 Hz
 Power consumption 16W
 Dimensions 420 (W) × 120 (H) × 265 (D) mm
 16-9/16 (W) × 4-3/4 (H) × 10-7/16 (D) in.
 Weight 3.9 kg (8 lbs. 10 oz.)

Accessories

Operating instructions 1
 Connection cord with pin plugs 2
 Remote control cord 1
 CD-DECK SYNCHRO control cord 1

Features

- DOLBY HX PRO recording function
- DOLBY B/C types NR
- Music search over ±15 selections
- Synchronized copy start
- High-speed and normal-speed copy (Deck I → Deck II)
- Relay playback/blank skip
- 6-segment LED level meter
- 3-digit mechanical tape counter (for Deck II)
- Automatic recording mute
- Automatic tape selectors
- System remote control available
- Timer recording
- Timer playback (Automatic relay on)
- CD-DECK SYNCHRO function
- Headphones jack (CT-W450R only)
- Automatic reverse (except Deck I of the CT-W355R)

NOTE

Specifications and design subject to possible modifications without notice due to improvements.

CT-W350R

System	4-track, 2-channel stereo
Heads	"Hard permalloy" recording/playback head × 1 "Hard permalloy" playback head × 1 "Ferrite" erasing head × 1
Motors	DC servo motor × 2
Wow and Flutter	
U.K. and European models	No more than 0.08% (WRMS) No more than ±0.19% (DIN)
Other models	No more than 0.10% (WRMS)
Fast Winding Time	Approx. 120 seconds (C-60 tape)
Frequency Response (at -20 dB recording level)	
Metal Tape	30 to 16,500 Hz
Chrome Tape	30 to 16,000 Hz
Normal Tape	30 to 16,000 Hz
Signal-to-Noise Ratio	
Dolby NR off	More than 56 dB
Noise Reduction Effect	
Dolby B-type NR ON	More than 10 dB (at 5 kHz)
Dolby C-type NR ON	More than 19 dB (at 5 kHz)
Harmonic Distortion	No more than 0.8% (at 0 dB)
Input (Sensitivity)	
LINE (INPUT)	63 mV (Input impedance 56 kΩ)
Output (Reference level)	
LINE (OUTPUT)	316 mV (Output impedance 4.5 kΩ)
Headphones	
(U.K. and European models only) ..	0.25 mW (Output impedance 8 Ω)

Miscellaneous

Power requirements	
U.S., Canadian model	AC 120 V, 60 Hz
U.K. and Australian models	AC 230-240 Volts ~, 50/60 Hz
European model	AC 220-230 Volts ~, 50/60 Hz
Multi-voltage model	AC 110 V/120 V-127 V/220 V/240 V (switchable), 50/60 Hz
Power consumption	
U.S., Canadian model	14 W
Other models	21 W
Dimensions	420 (W) × 120 (H) × 265 (D) mm 16-9/16 (W) × 4-3/4 (H) × 10-7/16 (D) in.
Weight	3.9 kg (8 lbs. 10 oz.)

Accessories

Operating instructions	1
Connection cord with pin plugs	2
Remote control cord	1
CD DECK SYNCHRO control cord	1

Features

- DOLBY NR B/C types
- Music search over ±15 selections
- Synchronized copy start
- High-speed and normal-speed copy (deck I — deck II)
- Relay playback/blank skip
- 6-segment LED level meter
- 3-digit mechanical tape counter (for deck II)
- Automatic recording mute
- Automatic tape selectors
- System remote control available
- Timer recording
- Timer playback (Automatic relay on)
- CD-DECK SYNCHRO function
- Headphones jack (U.K. and European models)
- Automatic reverse

NOTE

Specifications and design subject to possible modifications without notice due to improvements.

9. PANEL FACILITIES

CT-W450R AND CT-W355R

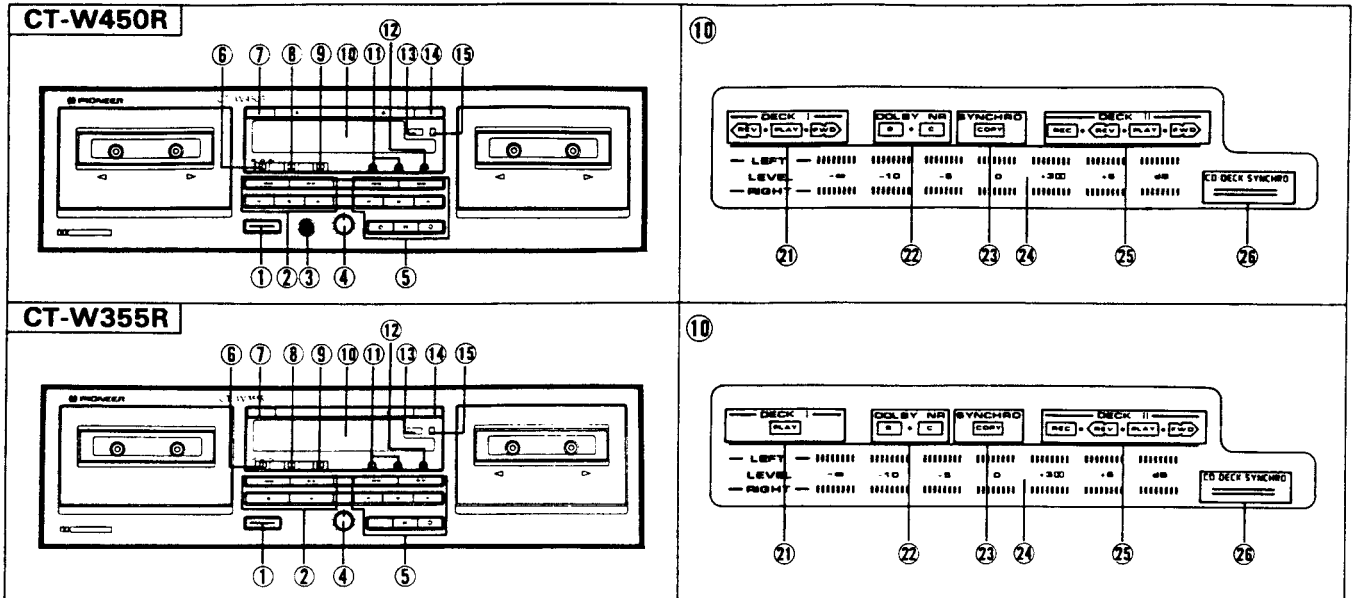

① POWER (STANDBY/ON) switch

NOTE:

The POWER switch activates the secondary transformer only. Even when the switch is in the STANDBY position, there will be a power flow to the deck's circuits as long as the power cord is connected to a power outlet.

② Deck I operation buttons

- ◀◀ Fast reverse/Music search
- ▶▶ Fast forward/Music search
- ▶ Forward playback
- Stop
- ◀ Reverse playback (CT-W450R only)

③ Headphones (PHONES) jack (CT-W450R only)

④ Recording level control (REC LEVEL)

⑤ Deck II operation buttons

- ◀◀ Fast reverse/Music search
- ▶▶ Fast forward/Music search
- ▶ Forward playback
- Stop
- ◀ Reverse playback
- Recording mute
- Pause
- Recording

⑥ Reverse mode switch (REV MODE)

- CT-W450R: For both Decks I and II.
- CT-W355R: For Deck II only

⑦ Deck I eject button (EJECT)

- If the tape is moving (recording, playback, tape winding, etc.), press the stop (■) button before pressing this button.

⑧ Dolby* NR switch (B/OFF/C)

⑨ Timer mode — Relay/Skip play switch (TIMER REC/OFF/PLAY — RELAY/SKIP)

⑩ Function display

⑪ Synchro copy buttons (SYNCHRO COPY I > II)

- NORMAL SPEED: Copying at normal speed.
- HIGH SPEED: Copying at twice normal speed.

⑫ CD-DECK SYNCHRO recording button (CD SYNCHRO)

⑬ Deck II tape counter (DECK II COUNTER)

⑭ Deck II eject button (EJECT)

- If the tape is moving (recording, playback, tape winding, etc.), press the stop (■) button before pressing this button.

⑮ Tape counter reset button (RESET)

Function display

⑰ Deck I tape transport mode indicators

⑱ Dolby NR indicators (B/C)

⑲ Synchro copy indicator (COPY)

- NORMAL SPEED: lights
- HIGH SPEED: flashes

⑳ Level meter

- The beside the +3 mark indicates the reference level for the Dolby NR system.

㉑ Deck II tape transport mode indicators

㉒ CD-DECK SYNCHRO recording indicator (CD-DECK SYNCHRO)

*

- Dolby noise reduction and HX Pro headroom extension manufactured under license from Dolby Laboratories Licensing Corporation. HX Pro originated by Bang & Olufsen.
- "DOLBY", the double-D symbol and "HX PRO" are trademarks of Dolby Laboratories Licensing Corporation.

CT-W350R

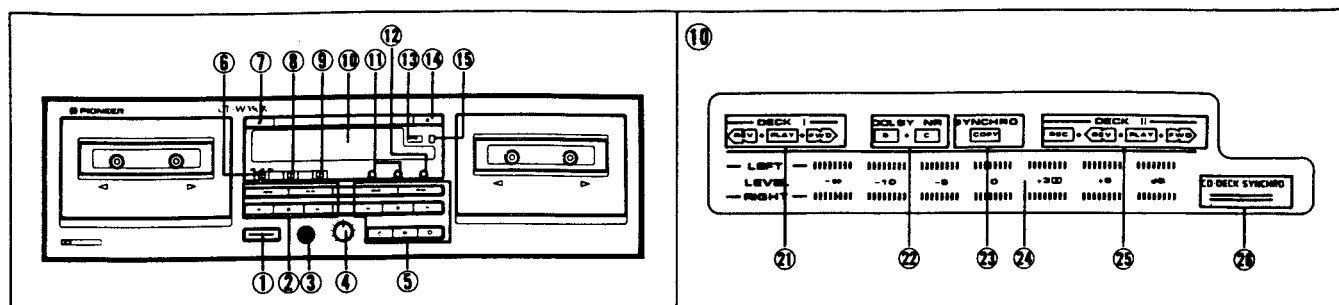

① POWER (STANDBY/ON) switch

NOTE:

The POWER switch activates the secondary transformer only. Even when the switch is in the STANDBY position, there will be a power flow to the deck's circuits as long as the power cord is connected to a power outlet.

② Deck I operation buttons

- ◀◀ Fast reverse/Music search
- ▶▶ Fast forward/Music search
- ▶ Forward playback
- Stop
- ◀ Reverse playback

③ Headphones (PHONES) jack (U.K. and European models)

④ Recording level control (REC LEVEL)

⑤ Deck II operation buttons

- ◀◀ Fast reverse/Music search
- ▶▶ Fast forward/Music search
- ▶ Forward playback
- Stop
- ◀ Reverse playback
- Recording mute
- || Pause
- Recording

⑥ Reverse mode switch (REV MODE)

⑦ Deck I eject button (EJECT)

- If the tape is moving (recording, playback, tape winding, etc.), press the stop (■) button before pressing this button.

⑧ Dolby* NR switch (B/OFF/C)

⑨ Timer mode — Relay/Skip play switch (TIMER REC/OFF/PLAY — RELAY/SKIP)

⑩ Function display

⑪ Synchro copy buttons (SYNCHRO COPY I > II)

- NORMAL SPEED: Copying at normal speed.
- HIGH SPEED: Copying at twice normal speed.

⑫ CD-DECK SYNCHRO recording button (CD SYNCHRO)

⑬ Deck II tape counter (DECK II COUNTER)

⑭ Deck II eject button (EJECT)

- If the tape is moving (recording, playback, tape winding, etc.), press the stop (■) button before pressing this button.

⑮ Tape counter reset button (RESET)

Function display

⑰ Deck I tape transport mode indicators

⑱ Dolby NR indicators (B/C)

⑲ Synchro copy indicator (COPY)

- NORMAL SPEED: lights
- HIGH SPEED: flashes

⑳ Level meter

- The beside the +3 mark indicates the reference level for the Dolby NR system.

㉑ Deck II tape transport mode indicators

㉒ CD-DECK SYNCHRO recording indicator (CD-DECK SYNCHRO)

- Dolby noise reduction manufactured under license from Dolby Laboratories Licensing Corporation.
- "DOLBY" and the double-D symbol are trademarks of Dolby Laboratories Licensing Corporation.