

Service Manual

PIONEER
The Art of Entertainment

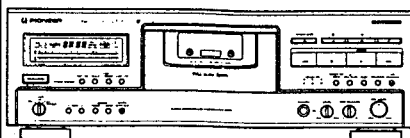

ORDER NO.
RRV1130

The chapter 1 of this Service Manual will not be reprinted. On your additional orders, we may supply only the chapter 2. For the chapter 1, please make copies and attach to the chapter 2 at your side if necessary.

STEREO CASSETTE DECK

CT-S830S

CT-S830S-G

THIS MANUAL IS APPLICABLE TO THE FOLLOWING MODEL(S) AND TYPE(S).

Type	Model		Power Requirement	The voltage can be converted by the following method.
	CT-S830S	CT-S830S-G		
HEM	○	○	AC220 - 230V	AC230 - 240V, *

* : Alter the wiring of the Power-supply block at the primary winding of power transformer referring to the "Line Voltage Selection" described in Service Manual.

CONTENTS

CHAPTER1

1.1 SPECIFICATIONS	1-2
1.2 PANEL FACILITIES.....	1-3
1.3 FL INFORMATION.....	1-4
1.4 ADJUSTMENTS	1-5
1.5 PARTS LIST FOR EXPLODED VIEWS AND PACKING	1-9
1.6 PCB PARTS LIST	1-12

CHAPTER2

2.1 BLOCK DIAGRAM	2-2
2.2 EXPLODED VIEWS AND PACKING	2-3
2.3 SCHEMATIC DIAGRAMS.....	2-9
2.4 PCB CONNECTION DIAGRAM.....	2-15

PIONEER ELECTRONIC CORPORATION 4-1, Meguro 1-Chome, Meguro-ku, Tokyo 153, Japan
PIONEER ELECTRONICS SERVICE INC. P.O. Box 1760, Long Beach, California 90801 U.S.A.
PIONEER ELECTRONICS OF CANADA, INC. 300 Allstate Parkway Markham, Ontario L3R 0P2 Canada
PIONEER ELECTRONIC [EUROPE] N.V. Haven 1087 Keetberglaan 1, 9120 Melsele, Belgium
PIONEER ELECTRONICS AUSTRALIA PTY. LTD. 178-184 Boundary Road, Braeside, Victoria 3195, Australia TEL: [03] 580-9911
© PIONEER ELECTRONIC CORPORATION 1994

T - SSK APR. 1994 Printed in Japan

CHAPTER 1

1.1 SPECIFICATIONS

System	4 track, 2 channel stereo
Heads	
Recording/Playback head:	
Combined Hard permalloy recording/Hard permalloy playback head x 1	
Erasing head: Ferrite head x 1	
Motor	DC servo capstan motor x 1 DC reel motor x 1 DC assist motor x 1
Wow and Flutter	0.023% (WRMS) ±0.056% (DIN)
Fast Winding Time	Approximately 80 seconds (C-60 tape)
Frequency Response	
-20 dB recording:	
TYPE IV (Metal) tape	15 to 25,000 Hz (±6 dB)
TYPE II (High/CrO ₂) tape	15 to 20,000 Hz (±6 dB)
TYPE I (Normal) tape	15 to 20,000 Hz (±6 dB)
Signal-to-Noise Ratio (Dolby NR off)	More than 60 dB
Noise Reduction Effect	
Dolby B-type NR ON	More than 10 dB (at 5 kHz)
Dolby C-type NR ON	More than 19 dB (at 5 kHz)
Dolby S-type NR ON (CT-S830S)	More than 22 dB (at 5 kHz)
Harmonic Distortion	No more than 0.6% (at -4 dB: 160 nwb/m)
Input (Sensitivity)	
LINE (INPUT)	100 mV (Input impedance 23 kΩ)
Output (Reference level)	
LINE (OUTPUT)	0.5 V (Output impedance 2.2 kΩ)
Headphone	9 mW (Load impedance 32 Ω, LEVEL control max.)

Subfunctions

- SUPER AUTO BLE system
- BIAS control
- Dolby HX Pro Headroom Extension system
- Dolby S-type noise reduction system (CT-S830S)
- Dolby B-type and C-type noise reduction systems
- MPX filter
- Level meter with 2 modes peak hold selection (12+1 segments)
- Level meter range selection (wide/expanded)
- 4-digit electronic tape counter with mode selection (Normal/Time/Remain)
- Auto monitor selection (Tape/Source)
- Display off
- Music search (over ±15 selections)
- Automatic Tape Loose Canceller (ATLC)
- Tape return/return play
- Auto space recording mute
- Auto tape selector
- Playback/recording timer start function
- CD•DECK SYNCHRO recording
- Headphones jack with level control
- Power eject (Open/Close)
- Repeat playback
- System remote control available
- Last memory

Miscellaneous

Power Requirements

European model	AC 220 — 230 Volts~, 50/60 Hz
Multivoltage model	AC 110/120 — 127/220/240 V (switchable), 50/60 Hz

Power consumption

CT-S830S	28 W
CT-S730	27 W

Dimensions	420 (W) x 140 (H) x 381 (D) mm
Weight (without package)	7.1 kg

Accessories

Operating instructions	1
Connection cord with pin plugs	2
CD•DECK SYNCHRO control cord	1
Remote control cord	1

NOTE:

Specifications and design subject to possible modifications without notice, due to improvements.

1.2 PANEL FACILITIES

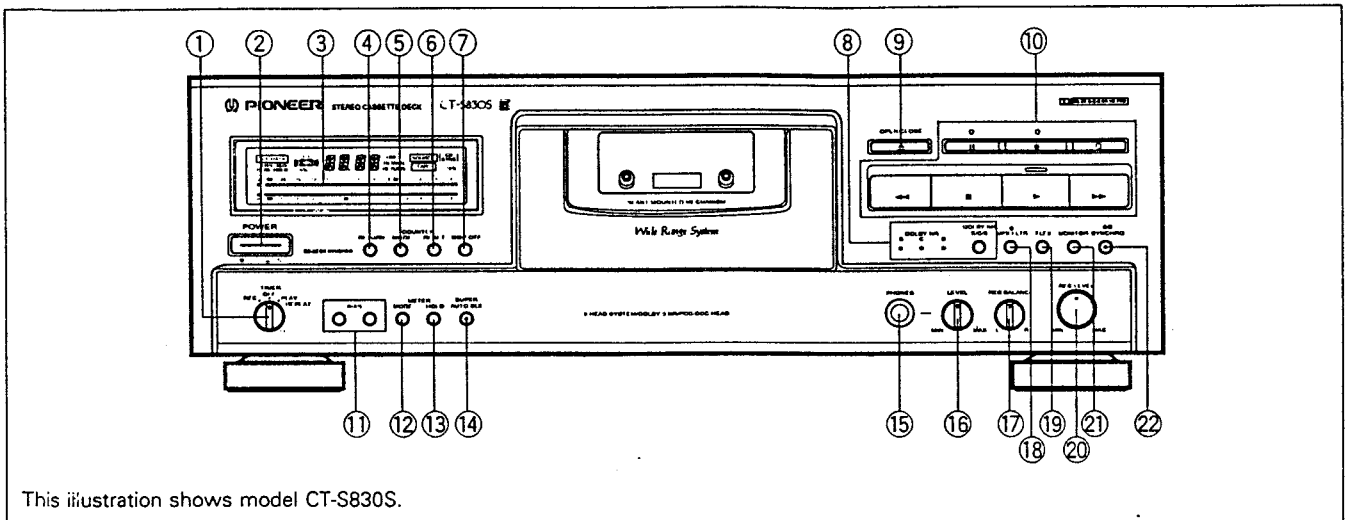

- 1 TIMER mode/repeat play switch (TIMER REC/OFF/PLAY-REPEAT)**
REC: Set to this position to perform timer recording.
OFF: Set to this position under ordinary conditions (when not using the timer or repeat functions).
PLAY-REPEAT:
 Set to this position to perform timer playback. When the switch is set to this position during normal playback, repeat playback of a single tape can be performed.
- 2 Power switch (POWER OFF/ ON)**
 After pressing the switch, the WAIT message will appear in the counter display and the level meter scale will flash for about four seconds (the time necessary for circuitry to stabilize). When the display is flashing, no operating buttons will respond, with the exception of the cassette door OPEN/CLOSE button (▲). To close the cassette door, do it while the power is turned on.
- 3 Function display**
- 4 Return button (RETURN)**
 This button is used in the normal tape counter mode to fast forward or rewind the tape to a point near the counter reading "0000".
- 5 Counter mode button (COUNTER MODE)**
 Each time this button is pressed, one of the three modes (Normal tape counter/Timer counter/Remaining time counter) is set in sequence.
- 6 Counter reset button (COUNTER RESET)**
 Reset the counter indication to "0000" in the normal tape counter or the time counter mode.
 To indicate the correct time value in the remaining time counter mode, this button must be set in accordance with the tape used.
- 7 Display off button (DISP OFF)**
 Press this button to turn off the function display.
- 8 DOLBY* NR button/indicators (OFF/B/C/S) (CT-S830S)**
DOLBY* NR button/indicators (OFF/B/C) (CT-S730)
 Press to select the Dolby NR system in the following order. The selected indicator lights up.
 For the CT-S830S: For the CT-S730:
 → OFF → B → C → S → OFF → B → C

When the DOLBY NR button is set to OFF, the DOLBY NR indicators go off.
- 9 OPEN/CLOSE button (▲)**
 Press this button to open or close the cassette door. Whenever inserting or removing a cassette tape, be sure that the power is turned on.
- 10 Operation buttons**
 ■ : Pause
 ● : Recording
 ○ : Recording mute
 ◀ : Rewind/music search
 ■ : Stop
 ▶ : Playback
 ▶▶ : Fast forward/music search
- 11 Recording bias buttons (BIAS -/+)**
 When desired, these buttons can be used to manually adjust the recording bias after performing SUPER AUTO BLE tuning.
 - : Changes tone by reducing recording bias
 + : Changes tone by increasing recording bias
- 12 Level meter mode selector button (METER MODE)**
 Switches between wide range, expanded range, and bias display.
- 13 Level meter hold button (METER HOLD)**
 Selects the display mode of the peak level.
 Press this button so that the PEAK HOLD indicator lights up. The level meter holds the maximum level indications of the signal. To erase the maximum level indications, press this button again. When the PEAK HOLD indicator goes off, the level meter holds peak indications for about 1.2 second.
- 14 SUPER AUTO BLE button**
- 15 Headphones jack (PHONES)**
- 16 Headphones level control (LEVEL)**
- 17 Recording balance control (REC BALANCE)**
- 18 MPX Filter button (MPX FLTR)**
 The indicator lights when the MPX Filter button is set to ON.
- 19 FLEX button**
- 20 Recording level control (REC LEVEL)**
- 21 Monitor selector button (MONITOR)**
 Used to monitor the source sound or adjust recorded sound during recording.
 ● When the unit is set to record or playback mode, the TAPE indicator lights up and monitor mode is automatically selected.
- 22 CD-DECK SYNCHRO recording button (CD SYNCHRO)**

- *Dolby noise reduction and HX Pro headroom extension manufactured under license from Dolby Laboratories Licensing Corporation. HX Pro originated by Bang & Olufsen.*
- *"DOLBY", the double-D symbol  and "HX PRO" are trademarks of Dolby Laboratories Licensing Corporation.*

ATLC (Automatic Tape Loose Canceler)

With the tape slack prevention function, when the cassette door closes, the reel automatically revolves to eliminate any tape slack.

1.3 FL INFORMATION

RAW1128 (V1501)

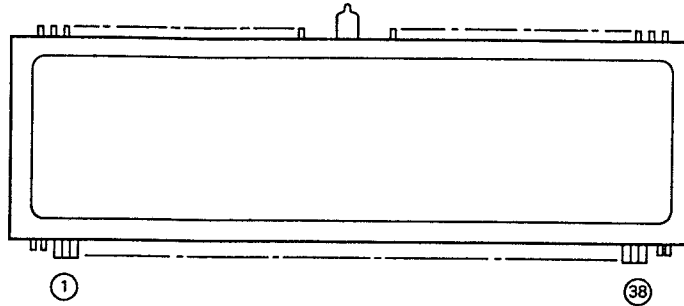

Pin Connection

TERMINAL NO. ELECTRODE	1	2	3	4	5	6	7	8	9	10	11	12	13	14	15	16	17	18	19	
	F1	F1	NP	NP	NC	8G	7G	6G	5G	4G	3G	2G	1G	P14	P13	P12	P11	P10	P9	
TERMINAL NO. ELECTRODE		20	21	22	23	24	25	26	27	28	29	30	31	32	33	34	35	36	37	38
		P8	P7	P6	P5	P4	P3	P2	P1	P0	NP	NP	NP	NP	NP	NP	NP	NP	F2	F2

Notes F : Filament G : Grid P : Anode NP : No pin

Grid Assignment

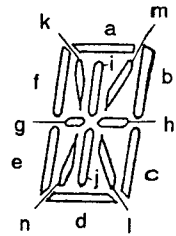
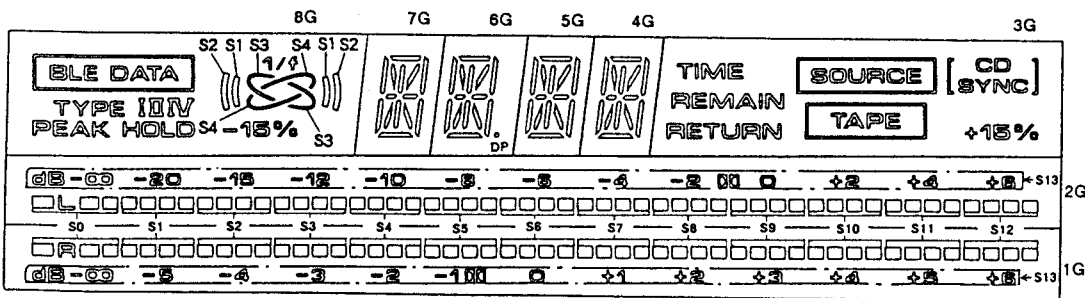

Anode Connection

	8G	7G	6G	5G	4G	3G	2G	1G
S0	1/f	a	a	a	a	TIME	S0	S0
S1	() S1	b	b	b	b	REMAIN	S1	S1
S2	() S2	c	c	c	c	RETURN	S2	S2
S3	S3	d	d	d	d	TAPE	S3	S3
S4	S4	e	e	e	e	SOURCE	S4	S4
S5	-	f	f	f	f	[CD] [SYNC]	S5	S5
S6	BLE DATA	g	g	g	g	+15%	S6	S6
S7	TYPE	h	h	h	h	-	S7	S7
S8	i	i	i	i	i	-	S8	S8
S9	II	j	j	j	j	-	S9	S9
S10	IV	k	k	k	k	-	S10	S10
S11	-15%	l	l	l	l	-	S11	S11
S12	HOLD	m	m	m	m	-	S12	S12
S13	PEAK	n	DP	n	n	-	S13	S13
S14	-	-	n	-	-	-	-	-

1.4 ADJUSTMENTS

1. MECHANICAL ADJUSTMENT

1. Tape Speed Adjustment			
Mode	Test tape	Adjustment position	Specification rating (playback frequency)
PLAY	Play the STD-301 tape (3kHz)	Tape speed adjustment hole	3000Hz \pm 5Hz

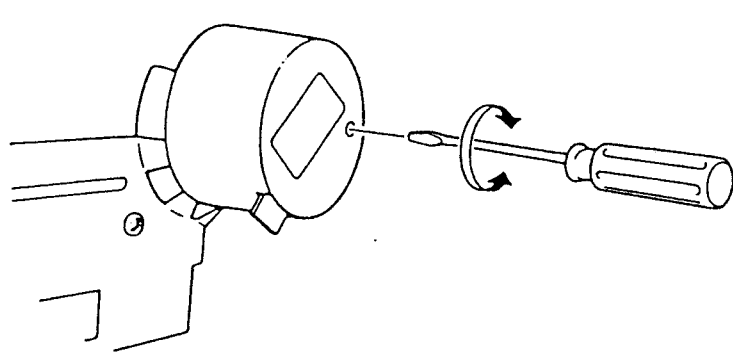

Fig. 1 Tape speed adjustment

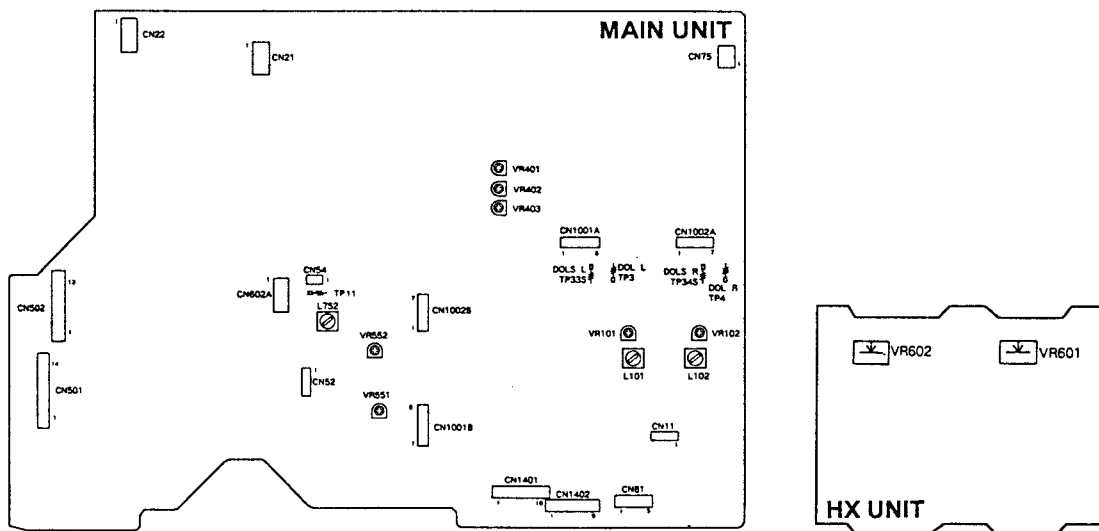

Fig. 2 Adjusting points

2. ELECTRICAL ADJUSTMENTS

Adjustment Conditions

1. The mechanical adjustments must be completed first.
2. The head must be cleaned and demagnetized.
3. Turn power on allow the deck to warm up for at least a few minutes before commencing any electrical adjustments.
4. The reference signal is 0 dBV=1 Vrms.
5. Connect a 10 kΩ load resistance to the OUTPUT terminals.
6. Unless otherwise specified, the switches listed below are left in the positions indicated.

DOLBY NR : OFF
 TAPE SELECTOR : NORM

Test Tapes

- STD-331E : Playback adjustments
 (See Fig. 3)
- STD-631 : NORMAL blank tape
 STD-621 : CrO₂ blank tape
 STD-610 : METAL blank tape

* As the reference recording level is 250 nwb/m for STD-331E, the recording level will be higher by 4 dB for STD-331B (160 nwb/m). When adjusting, pay carefull attention to the type of tape used.

List of Adjustments

Playback sections

1. Head azimuth adjustment.
2. Playback level adjustment.

Recording sections

1. Bias oscillator adjustment.
2. Bias trap adjustment.
3. Recording bias adjustment.
4. Recording level adjustment.
5. AUTO BLE adjustment.

NOTE: This unit has an automatic tape selection feature.

Dolby noise reduction and HX Pro headroom extension manufactured under license from Dolby Laboratories Licensing Corporation. HX Pro originated by Bang & Olufsen. "DOLBY", the double-D symbol \square and "HX PRO" are trademarks of Dolby Laboratories Licensing Corporation.

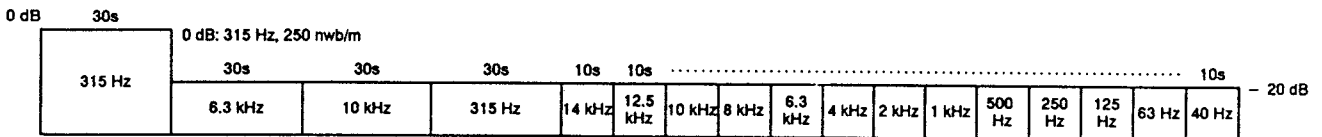

Fig. 3 Constants of the test tape STD-331E

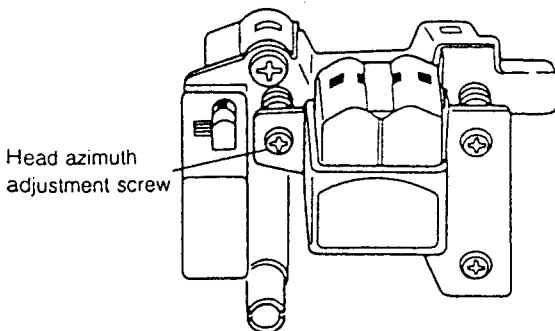
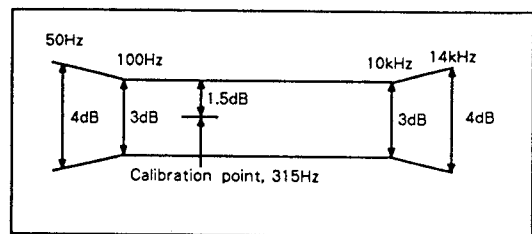

Fig. 4 Head azimuth adjustment

PLAY BACK



RECORDING

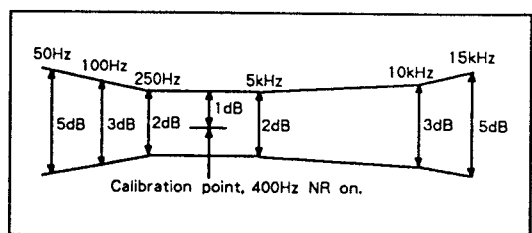

Fig. 5 Frequency response zone

PLAYBACK SECTION

1. Head Azimuth Adjustment

- Turn VR101, 102 to mechanical center positions.

No.	Mode	Input signal & test tape	Adjustment location	Measuring location	Adjustment value	Remarks
1.	PLAY	Play the 10 kHz/-20 dB section of STD-331E test tape.	Head azimuth adjustment screw. (See Fig. 4)	LINE OUT	Maximum playback signal level.	
2.	STOP	Lock the screw with screw lock after completing adjustment.				

Note: The left and right phase difference for the 12.5 kHz tone should be within 75 degrees. (That for the 10 kHz tone should be within 60 degrees.)

2. Playback Level Adjustment

- This adjustment determines the DOLBY NR level, and must be performed with great care.

No.	Mode	Input signal & test tape	Adjustment location	Measuring location	Adjustment value	Remarks
1.	PLAY	Play the 315 Hz/0 dB section of the STD-331E test tape.	Deck VR101 (Lch) VR102 (Rch)	TP. 3 (Lch) TP. 4 (Rch)	- 7.2 dBV	
2.	Set the DOLBY NR switch to the S position.					
3.	PLAY	Play the 315 Hz/0 dB section of the STD-331E test tape.		TP. 33S (Lch) TP. 34S (Rch)	-7.2 dBV ± 0.5 dB	

RECORDING SECTION

1. Bias Oscillator Adjustment

No.	Mode	Input signal & test tape	Adjustment location	Measuring location	Adjustment value	Remarks
1.	REC/ PLAY	Load the STD-610 test tape with no input signal.	Deck L752	TP. 11	105 kHz ± 300 Hz	

2. Bias Trap Adjustment

No.	Mode	Input signal & test tape	Adjustment location	Measuring location	Adjustment value	Remarks
1.	REC/ PLAY	Load the STD-610 test tape with no input signal.	Deck L101 (Lch) L102 (Rch)	LINE OUT	Minimum output	

3. Recording Bias Adjustment

- After the adjustment, Caution should be exercised so as not to become under bias by checking the distortion rate.
- Set the DOLBY NR switch to the OFF position.

No.	Mode	Input signal & test tape	Adjustment location	Measuring location	Adjustment value	Remarks
1.	REC/ PLAY	Record the 315 Hz and 10kHz signals at - 26 dBV input level onto the STD - 631 test tape, and Playback.	Deck VR601 (Lch) VR602 (Rch)	LINE OUT	Repeatedly record, playback and adjust so that the playback level of 10 kHz signal becomes 0 dB ± 0.5dB when compared with the 315Hz signal.	

4. Recording Level Adjustment

- Set the DOLBY NR switch to the OFF position.

No.	Mode	Input signal & test tape	Adjustment location		Measuring location	Adjustment value	Remarks
1.	REC PAUSE	Apply a 315 Hz/ - 4 dBV signal to the line input terminals, load the STD-631 test tape.	REC level control volume		TP. 1 (Lch) TP. 2 (Rch)	-11.2 dBV	
2.	REC/ PLAY	Record the above signal onto the STD - 631 test tape, and playback.	Deck	VR551 (Lch) VR552 (Rch)	TP. 3 (Lch) TP. 4 (Rch)	Repeatedly record, playback and adjust so that the playback signal level becomes -11.2 dB.	
3.	REC/ PLAY	Record the above signal onto the STD - 621 test tape, and playback.	Check			-11.2 dBV ± 1 dB	
4.	REC/ PLAY	Record the above signal onto the STD - 610 test tape, and playback.	Check			-11.2 dBV ± 1 dB	
5.	STOP	Set the DOLBY NR switch to the S position.					
6.	REC/ PLAY	Record the above signal onto the STD - 631 test tape, and playback.	Check		LINE OUT	0 dB ± 1.0 dB for paragraph 2.(* 1)	

* 1: If this confirmation value cannot be obtained, perform "Playback Level Adjustment" once again.

5. AUTO BLE Adjustment

- BLE Adjustment must be performed after all other adjustments are completed.
- This adjustment should be performed in the test mode.
- Entering the test mode

Press the COUNTER MODE, COUNTER RESET and PAUSE keys on the front panel simultaneously, with the power ON. The unit enters the test mode and oscillates a 400 Hz signal.

Thereafter, each time the AUTO BLE key is pressed, the oscillation frequency changes as follows: 3 kHz oscillation → 15 kHz oscillation → 400Hz oscillation

No.	Mode	Input signal & test tape	Adjustment location	Measuring location	Adjustment value	Remarks
1.		Set to test mode	-	-		
2.		Press the AUTO BLE key on the front panel.	VR401	Level meter Lch	Adjust the Lch segment which is lit until Rch is not lighting up. Lch ■→□ Rch ■■□■■■ (■ : light up □ : not light up)	400 Hz adjustment (FL indication 1)
3.		Press the AUTO BLE key on the front panel.	VR402			3 kHz adjustment (FL indication 2)
4.		Press the AUTO BLE key on the front panel.	VR403			15 kHz adjustment (FL indication 3)
5.	When the COUNTER RESET key is pressed again, the test mode is released.					

1.5 PARTS LIST FOR EXPLODED VIEWS AND PACKING

NOTES:

- Parts marked by "NSP" are generally unavailable because they are not in our Master Spare Parts List.
- The Δ mark found on some component parts indicates the importance of the safety factor of the part. Therefore, when replacing, be sure to use parts of identical designation.
- Parts marked by "⊙" are not always kept in stock. Their delivery time may be longer than usual or they may be unavailable.

1. EXTERIOR

■ CONTRAST OF CT-S830S/HEM AND CT-S830S-G/HEM

CT-S830S/HEM and CT-S830-G/HEM have the same construction except for the following:

Mark	No.	Symbol & Description	Part No.		Remarks
			CT-S830S/HEM	CT-S830S-G/HEM	
	18	Panel stay	RNT1197	RNT1198	
	19	Operation button	RAC1900	RAC1897	
	20	VR knob	RAC1902	RAC1899	
	21	Rotary knob	RAC1903	RAC1895	
	22	Power button	RAC1904	RAC1894	
	24	Lower panel	RAH2408	RAH2404	
	27	Front panel	RAH2409	RAH2403	
	29	Bonnet assy	REA1131	REA1132	
	30	Rear panel	RNA1810	RNA1805	
	31	Door	RNK2083	RNK2081	
	32	Escutcheon mold	RNK2085	RNK2082	
	36	Lower mold	RNK2081	RNK2080	
	37	Name plate	VAM1032	RAN1011	

■ PARTS LIST FOR CT-S830S/HEM

Mark	No.	Description	Part No.	Mark	No.	Description	Part No.
Δ	1	Strain relief	CM - 22B		31	Door	RNK2083
Δ	2	AC power cord	PDG1003		32	Escutcheon mold	RNK2065
Δ	3	Fuse (T1.6A)	REK - 102		33	LED lens 1	RNK2066
Δ	4	Power transformer	RTT1233		34	Lens L	RNK2067
	5	Mechanism unit	RYM1232		35	Spacer	REC1197
NSP	6	Cord stopper	DNF1128		36	Lower mold	RNK2081
	7	Door spring	RBH1395		37	Name plate	VAM1032
NSP	8	Rubber spacer (A)	REB1057		38	Screw	BBT30P100FZK
	9	Door cushion	REB1174		39	Screw	BBZ26P080FZK
	10	Protector	RED1020		40	Screw	BBZ30P060FCC
NSP	11	Main chassis	RNB1059		41	Screw	FBT40P080FZK
NSP	12	PCB base	RNE1221		42	Screw	IBZ30P060FCC
	13	VR shield plate	RNE1773		43	Screw	IBZ30P060FCC
	14	HP holder	RNE1776		44	Screw	IBZ30P080FCC
	15	Cord clamper	RNH - 184		45	Screw	IBZ30P100FCC
	16	Panel stay	RNT1197		46	Screw	IBZ40P080FCC
	17	Snap plate	VNE1102	NSP	47	Binder	Z09 - 058
	18	Insulator	PNW1912	NSP	48	HPHN unit	RWZ3232
	19	Operation button	RAC1900		49	FL unit	RWZ3234
	20	VR knob	RAC1902		50	OPSW unit	RWZ3236
	21	Rotary knob	RAC1903	NSP	51	VR unit	RWZ3270
	22	Power button	RAC1904		52	MAIN unit	RWZ3272
	23	FL filter	RAH1936		53	HX unit	RWX1069
	24	Lower panel	RAH2406		54	1/F unit	RWX1086
	25	FL lens	RAH2407		55	Dolby S unit	RWX1103
	26	Door lens	RAH2408	NSP	56	PWSW unit	RWZ3275
	27	Front panel	RAH2409	NSP	57	TRN 2 unit	RWZ3279
	28	Door sheet	REB1191	NSP	58	TRN 1 PCB	RNZ2452
	29	Bonnet assy	REA1131	NSP	59	UL tube	Z09 - 019
	30	Rear panel	RNA1810				

CT-S830S, CT-S830S-G

2. MECHANISM UNIT

Mark	No.	Description	Part No.	Mark	No.	Description	Part No.
	1	Rotary encoder	RSX1004		51	Head base set spring	RBL - 026
	2	Capstan motor assembly	RXX1491		52	Gear chassis assembly	RXA1171
	3	Reel motor assembly	REA1075		53	Screw	BBZ26P080FZK
	4	Step screw	RBA - 064		54	Pinch base assembly	RXB - 878
	5	Cassette plate assembly	RXX1064		55	Screw	BBZ30P080FZK
	6	Rubber cushion	REB1125		56	Eject lever	RNK1763
	7	Pinch spring	RBL - 028		57	Screw	BCZ30P060FMC
	8	Pinch thrust spring	RBL - 030		58	Screw	BMZ26P030FZK
	9	Sub - pinch spring	RBL - 098		59	Screw	IBZ20P060FMC
	10	Capstan belt	REB1143		60	Screw	BMZ26P060FZK
	11	Capstan belt (A)	REB - 509		61	Screw	BMZ30P080FZK
	12	Tape guide	RNK1823		62	Screw	PMZ30P040FMC
	13	Flywheel assembly	RXA1374		63	Screw	PMA26P050FZK
	14	Sub - flywheel assembly	RXA1375		64	Screw	PMA26P060FZK
	15	Metal holder assembly (A)	RXA1426		65	Screw	PMZ20P080FZK
	16	Metal holder assembly (B)	RXA1343		66	Washer	RBF - 030
	17	Pinch roller arm (R) assembly	RXB - 876		67	Stabilizer (B)	REB1038
	18	Pinch roller arm (A) assembly	RXB - 877		68	Earth spring	RBL - 059
	19	BT spring (A)	RBL - 031		69	Washer	RBF - 076
	20	BT spring (B)	RBL - 032		70	Washer	RBF1040
	21	Idler pressure spring	RBL - 033		71	Binder	REC - 371
	22	Reel shaft cap (B)	RNK - 815		72	Steel ball (3mm)	REF - 022
	23	BT disk assembly	RXB - 751		73	Steel ball (4mm)	REF - 023
	24	Reel base assembly	RXB - 874		74	Screw	VCT30P060FZK
	25	Take - up idler assembly	RXA1554		75	LED (D3)	SLF - 401C
	26	Washer	RBF - 065		76	Washer	WA21D040D013
	27	Head base spring	RBL - 037		77	Washer	WA26N070W040
	28	Brake spring	RBL - 038		78	Washer	WA32D080D050
	29	Drive belt	REB1182		79	E ring	YE20FUC
	30	Brake shoe	REB - 511		80	E ring	YE25FUC
	31	Brake	RNL - 723		81	E ring	YE30FUC
	32	Cam gear	RNK1640		82	Snap ring	YS24FBT
	33	Side cam gear	RNK1765		83	Shift shaft assembly	RXB - 885
	34	Stabilizer	REB1161		84	Head base assembly	RXX1333
	35	Eject spring	RBL - 039		85	Mechanism chassis assembly	RXA1366
	36	Half set arm spring	RBL - 040		86	Brake lever	RNK1638
	37	REC functioning spring	RBL - 041		87	Second pulley assembly	RXA1350
	38	Detection functioning spring	RBL - 042		88	Door frame (L)	RNE1774
	39	Reel motor mounting plate	RNE1604		89	Pinch lever assembly	RXA1360
	40	Flywheel holder	RNH - 304		90	Door frame (R)	RNE1775
	41	Cord clasper	RNH - 184		91	Damper assembly	VXA1153
	42	Washer	RBF - 057		92	Half pressure spring	RBK1004
	43	REC detector arm	RNL - 733		93	Door pocket	RNK1764
	44	Chrom detector arm	RNL - 734		94	Loading motor	VXM1034
	45	Metal detector arm	RNL - 735		95	Screw	PBZ20P060FMC
	46	Thrust holder	RNL - 743		96	Capstan motor	RXM1054
	47	Motor pulley	PNW1634		97	Reel motor	RXM1065
	48	Pressure arm (R)	RNL - 725		98	2.5mm pitch side post (5P)	BS5P - SHF - 1
	49	Collar	RNL - 742		99	Connector assembly (4P)	RKP1383
	50	Pressure arm (L)	RNL - 726		100	Connector assembly (2P)	RKP1384

3. PACKING

Mark	No.	Description	Part No.	Mark	No.	Description	Part No.
NSP	101	Gear base assembly	RXB - 882	1	Pad (F)	RHA1145	
NSP	102	E head	RPB1042	2	Pad (R)	RHA1146	
NSP	103	R & P head	RPB1041	3	Packing case (CT-S830S/HEM)	RHG1555	
NSP	104	Connector unit	RWZ1751	3	Packing case (CT-S830S-G/HEM)	RHG1559	
NSP	105	Adjustment nut	RBA1047	4	Sheet	RHX1007	
NSP	106	Head adjustment spring C	RBL - 034	5	Control cord (For CD • DECK SYNCHRO)	RDE1038	
NSP	107	Hight spring	RBL - 036	6	Operating instructions (English/Spanish)	RRE1094	
NSP	108	Head base	RNK1645	7	Connection cord (For SR cord)	PDE1247	
NSP	109	Sub - head base	RNG - 335	8	Connection cord assembly	RDE1036	
NSP	110	E head base	RNG1033	9	Operating instructions (French/German/Italian/ Dutch/Swedish/Portuguese)	RRD1146	
NSP	111	Earth lead assembly	RDF - 001	10	Vinyl bag	Z21 - 038	
NSP	112	REC switch unit	RWZ1749				
NSP	113	Tape selector unit	RWZ1750				
NSP	114	Sensor unit (B)	RWZ1753				
NSP	115	Cassette plate	RAH1306				
NSP	116	Lead wire holder	RNL - 793				
NSP	117	Shift roller	RNL - 731				
NSP	118	Sensor unit (A)	RWZ1752				
NSP	119	Motor pulley	RNK1676				
NSP	120	Reel motor pulley	RLA1186				
NSP	121	Connector assembly (4P)	RKP1111				
NSP	122	Connector assembly (2P)	RKP - 895				
NSP	123	Friction spring	RBL - 047				
NSP	124	Spring cup	RNL - 012				
NSP	125	Idle pulley	RNL - 549				
NSP	126	Idler arm	RNK1908				
	127	Spacer	REF1004				

1.6. PCB PARTS LIST

NOTES:

- Parts marked by "NSP" are generally unavailable because they are not in our Master Spare Parts List.
- The Δ mark found on some component parts indicates the importance of the safety factor of the part. Therefore, when replacing, be sure to use parts of identical designation.
- Parts marked by "⊙" are not always kept in stock. Their delivery time may be longer than usual or they may be unavailable.
- When ordering resistors, first convert resistance values into code form as shown in the following examples.

Ex.1 When there are 2 effective digits (any digit apart from 0), such as 560 ohm and 47k ohm (tolerance is shown by J=5%, and K=10%).

560 Ω \rightarrow $56 \times 10^1 \rightarrow$ 561 RD1/8PM $\begin{matrix} 5 & 6 & 1 \\ \hline \end{matrix}$ J
 47k Ω \rightarrow $47 \times 10^3 \rightarrow$ 473 RD1/4PS $\begin{matrix} 4 & 7 & 3 \\ \hline \end{matrix}$ J
 0.5 Ω \rightarrow 0R5 RN2H $\begin{matrix} 0 & R & 5 \\ \hline \end{matrix}$ K
 1 Ω \rightarrow 010 RS1P $\begin{matrix} 0 & 1 & 0 \\ \hline \end{matrix}$ K

Ex.2 When there are 3 effective digits (such as in high precision metal film resistors).

5.62k Ω \rightarrow $562 \times 10^1 \rightarrow$ 5621 RN1/4PC $\begin{matrix} 5 & 6 & 2 & 1 \\ \hline \end{matrix}$ F

Mark	No.	Description	Part No.	Mark	No.	Description	Part No.
------	-----	-------------	----------	------	-----	-------------	----------

LIST OF ASSEMBLIES

					IC543		TC4050BP
NSP	MOTHER UNIT	RWM1716			IC251		TC4052BP
	├ MAIN UNIT	RWZ3272			IC151, IC351		TC4066BP
	│ └ HX UNIT	RWX1069	Δ		Q801		2SA1283
	│ └ 1/F UNIT	RWX1086			Q701, Q871-Q874, Q902		2SA1309A
	│ └ DOLBY S UNIT	RWX1103		Δ	Q904		2SB1185
NSP	└ PWSW UNIT	RWZ3275			Q751, Q752		2SC3243
NSP	└ TRN 2 UNIT	RWZ3279			Q621, Q630, Q831-Q833, Q901		2SC3311A
NSP	└ TRN 1 PCB	RNZ2452		Δ	Q903		2SD1762
NSP	SUB UNIT	RWM1701			Q251, Q252, Q305, Q306		2SD2144S
NSP	├ HPHN UNIT	RWZ3232			Q551, Q552, Q557, Q558, Q753		2SD2144S
NSP	├ FL UNIT	RWZ3234			Q304		2SK246
NSP	├ OPSW UNIT	RWZ3236			Q142, Q163, Q302, Q771, Q835		DTA124ES
NSP	└ VR UNIT	RWZ3270			Q952, Q971-Q974		DTA124TS
	JUNCTION CIRCUIT UNIT	RWM1615			Q101, Q102, Q875		DTC114ES
NSP	├ REC SWITCH UNIT	RWZ1749			Q851, Q852		DTC114TS
NSP	├ TAPE SELECTOR UNIT	RWZ1750			Q141, Q161, Q162, Q301		DTC124ES
NSP	├ CONNECTOR UNIT	RWZ1751			Q401, Q402, Q461-Q476		DTC124ES
NSP	├ SENSOR UNIT(A)	RWZ1752			Q501, Q502, Q521, Q522		DTC124ES
NSP	└ SENSOR UNIT(B)	RWZ1753			Q553-Q555, Q624-Q629		DTC124ES
					Q735-Q738, Q834, Q951		DTC124ES
					Q622, Q623		DTC124TS
				Δ	D901-D904		10DF2FA9
				Δ	D801, D811, D871		1SR35-100AVL
					D813, D814		1SS252
					D101-D104, D141, D301, D302		1SS254
					D501-D506, D701, D703-D713		1SS254
					D751, D831, D832, D951-D960		1SS254
					D971-D976		1SS254
Δ	IC901, IC902	ICP-N20			D905, D906		HZS6C1L
	IC702	LC7570		Δ	D833		MTZ3. 6B
	IC141, IC903	M5218AP					
	IC101	M5220P					
Δ	IC812	NJM7805FA		Δ	D803		MTZJ33B
					D702		MTZJ9. 1A/B
Δ	IC811	NJM7812FA		Δ	D802		MTZJ9. 1C
	IC703	NM93C46N		Δ	D812		S2VB20
	IC701	PD4444A					
	IC851	TA7291P					

MAIN UNIT

SEMICONDUCTORS

	IC521	BA10339					
	IC401, IC501	BA15218N					
	IC871	BA6109					
	IC551	CXA1198AP					
	IC121, IC321	CXA1330S					
Δ	IC901, IC902	ICP-N20					
	IC702	LC7570					
	IC141, IC903	M5218AP					
	IC101	M5220P					
Δ	IC812	NJM7805FA		Δ	D803		MTZJ33B
					D702		MTZJ9. 1A/B
Δ	IC811	NJM7812FA		Δ	D802		MTZJ9. 1C
	IC703	NM93C46N		Δ	D812		S2VB20
	IC701	PD4444A					
	IC851	TA7291P					

Mark	No.	Description	Part No.	Mark	No.	Description	Part No.
COILS AND FILTERS							
	L751		LFA121K		C903, C904 (2200/25)		RCH1096
	L752		RTD1057		C911, C912 (220/25)		RCH1103
	L101, L102		RTF1060		C816 (10000/16)		VCH1054
	L851		RTF1068				
	L551, L552		RTF1094				
	F301, F302		RTF1210				
CAPACITORS							
	C871		CEANP4R7M35		RESISTORS		
	C251, C401, C551, C552, C564		CEAS010M50		R701, R702, R707		RA4T223J
	C954		CEAS010M50		R545		RA5T223J
	C4, C503, C504, C771, C852		CEAS100M50		R705, R706, R712		RA7T223J
	C751, C815, C875		CEAS101M16		R369, R370 (560Ω)		RCN1024
			CEAS101M16		R153, R154, R157, R158 (12K)		RCN1064
	C802, C804		CEAS101M50		R546 (11K/22K)		RCX1020
	C817		CEAS102M6R3		R608		RD1/2LMF010J
	C509, C756, C874		CEAS330M16		R855		RD1/2LMF100J
	C702, C721, C833		CEAS470M16		R802		RD1/2LMF562J
	C129, C130, C317, C318, C872		CEASR22M50		R753, R754		RD1/2LMF6R2J
	C127, C128, C131, C132		CEASR33M50		R327, R328		RDR1/4PM103J
	C315, C316, C319, C320		CEASR33M50		R257, R258		RDR1/4PM471J
	C505, C506		CEASR47M50	△	R801		RFA1/4L470J
	C133, C134, C252, C253		CENA101M25		R871		RS1LMF010J
	C323, C324		CENA101M25				
				△	R903, R904		RS1LMF151J
	C113, C114, C147-C150		CENA470M25		R803		RS1LMF152J
	C559, C560		CENA470M25		VR551, VR552 (22K)		RCP1046
	C305, C306		CEYA010M50		VR101, VR102, VR401, VR403 (47K)		RCP1047
	C141, C142, C145, C146		CEYA100M50				
	C353, C354, C907, C908		CEYA100M50		VR402 (100K)		RCP1048
					Other Resistors		RD1/6PM□□□□J
	C107, C108, C135, C136		CEYA220M25				
	C555, C556		CEYA220M25		OTHERS		
	C137, C138, C321, C322		CEYA330M25		CN75, CN76 JUMPER CONNECTOR 3P		KPC3
	C121, C122, C309, C310		CEYA4R7M50		CN21, CN22 JANPER CONNECTOR 5P		KPC5
	C553, C554, C831, C832		CEYA4R7M50		JA953 MINI JACK		PKN1005
					JA251, JA301 JACK 2P		RKB1020
	C123-C126, C311-C314		CFTXA222J50		JA951, JA952 REMOTE CONTROL JACK		RKN1004
	C405, C753, C754		CFTXA332J50				
	C406, C755		CFTXA682J50		CN81 JUMPER CONNECTOR 5P		SBRK05S
	C752		CFTYA223J50		CN1402 JUMPER CONNECTOR 9P		SBRK09S
	C109, C110, C402		CFTYA273J50		CN1401 JUMPER CONNECTOR 10P		SBRK10S
					CN502 JUMPER CONNECTOR 13P		SBRK13S
	C501, C502		CFTYA473J50		CN501 JUMPER CONNECTOR 14P		SBRK14S
	C105, C106, C403, C909, C910		CFTYA563J50				
	C255-C257		CKCYB561K50		EARTH PLATE		VNF-091
	C541, C701, C703-C705, C722		CKCYF103Z50		X701 CERAMIC RESONATOR (4.19MHz)		VSS1014
	C873, C951, C952		CKCYF103Z50		CN54 SP CONNECTOR		W-P5102#51
					CN52 SP CONNECTOR		W-P5104#52
	C254, C303, C801, C803		CKCYF473Z50		CN11 SP CONNECTOR		W-P5104#56
	C811-C813, C851, C901, C902		CKCYF473Z50				
	C953		CKCYF473Z50		HX UNIT		
	C103, C104, C507, C508		CKPUYB101K50		SEMICONDUCTORS		
	C111, C112, C557, C558		CKPUYB102K50		IC601		UFC1297CA
					Q602		2SA1309A
	C254, C303, C801, C803		CKCYF473Z50		Q603		DTC124ES
	C811-C813, C851, C901, C902		CKCYF473Z50		D602		1SS254
	C953		CKCYF473Z50				
	C103, C104, C507, C508		CKPUYB101K50		COILS AND FILTERS		
	C111, C112, C557, C558		CKPUYB102K50		L601, L602 (4.6MH)		RTD1011
	C143, C144		CKPUYB122K50				
	C407		CQMA103J50		CAPACITORS		
	C404		CQMA823J50		C609, C610		CCCSL101K500
	C757		CQPA752J100		C616, C617		CEAS330M35
	C101, C102		CQSA221J160		C614		CEASR10M50
					C601, C602		CFTXA103J50
	C814 (6800/25)		RCH1033				

CT-S830S, CT-S830S-G

Mark No.	Description	Part No.	Mark No.	Description	Part No.
C605, C606 C607, C608 C613 C603, C604 C611, C612 (390P/500)		CFTXA223J50 CGCYX223K25 CKPUYB101K50 CKPUYB821K50 RCG1004	C1093, C1094 C1005, C1006, C1061, C1062 C1063, C1064 C1047, C1048 C1011, C1012 C1017, C1018, C1053, C1054 C1021, C1022, C1039, C1040 C1089, C1090 (10/25) C1085, C1086 (22/25) C1029, C1030, C1035, C1036 (47/16)	CKSQYB333K50 CKSQYB393K50 CKSQYB471K50 CKSQYB473K50 CKSQYB681K50 CKSQYB822K50 CKSQYB823K25 RCH1093 RCH1094 RCH1095	
RESISTORS VR601, VR602 Other Resistors		VRTB6HS473 RD1/6PM□□□J	RESISTORS All Resistors		RS1/10S□□□J
1/F UNIT			OTHERS CN1002 CN1001		6034B-072001 6034B-082001
SEMICONDUCTORS IC1111, IC1131 Q1131-Q1136 D1111		BA15218N DTC124ES 1SS254	PWSW UNIT		
CAPACITORS C1141-C1143 C1117, C1118 C1139, C1140 C1119 C1133, C1134 C1135, C1136 C1115, C1116 C1120 C1137, C1138 C1111, C1112 C1113		CEAS010M50 CEAS101M10 CEAS4R7M50 CEASR47M50 CGCYX152K25 CGCYX272K25 CGCYX332K25 CGCYX473K25 CGCYX562K25 CGCYX822K25 CKPUYB101K50	SWITCHES AND RELAYS △ S991		RSA1001
RESISTORS All Resistors		RD1/6PM□□□J	CAPACITORS △ C991		VCG-044
DOLBY S UNIT			OTHERS △ TERMINAL		RKC-061
SEMICONDUCTORS IC1001, IC1002 IC1003		CXA1417Q M5218AFP	TRN 2 UNIT TRN 2 unit has no service part.		
CAPACITORS C1003, C1004, C1015, C1016 C1051, C1052 C1033, C1034 C1001, C1002, C1031, C1032 C1045, C1046, C1091, C1092 C1027, C1028, C1041, C1042 C1075, C1076 C1019, C1020 C1037, C1038 C1013, C1014, C1055, C1056 C1007, C1008, C1025, C1026 C1043, C1044, C1067, C1068 C1077, C1078, C1081, C1082 C1087, C1088 C1023, C1024, C1049, C1050 C1065, C1066, C1069-C1072 C1083, C1084 C1079, C1080 C1059, C1060 C1009, C1010, C1073, C1074		CEJA010M50 CEJA010M50 CEJAR10M50 CEJAR22M50 CEJAR22M50 CEJAR47M50 CEJAR47M50 CFTYA224J50 CFTYA334J50 CKSQYB102K50 CKSQYB104K25 CKSQYB104K25 CKSQYB104K25 CKSQYB104K25 CKSQYB153K50 CKSQYB182K50 CKSQYB182K50 CKSQYB183K50 CKSQYB222K50 CKSQYB223K50	TRN 1 PCB TRN1 PCB has no service part.		
			HPHN UNIT		
			SEMICONDUCTORS IC201		M5218AP
			CAPACITORS C201, C202 C203, C204		CEAS010M50 CEAS101M10
			RESISTORS VR201 (20KB) Other Resistors		PCS1002 RD1/6PM□□□J
			OTHERS JA201		RKN1002
			FL UNIT		
			SEMICONDUCTORS D1501-D1510, D1512, D1513		1SS254
			SWITCHES AND RELAYS S1511 S1501-S1509		RSB1011 RSG1039
			OTHERS V1501 FL INDICATOR TUBE		RAW1128

Mark No.	Description	Part No.
OPSW UNIT		
SEMICONDUCTORS		
Q1409		DTA124TS
Q1401-Q1408		DTC124ES
D1409-D1411		ISS254
D1407		SEL6410E
D1401-D1403, D1405		SEL6910A
D1406, D1408		SEL6C10R
SWITCHES AND RELAYS		
S1401-S1413		RSG1030
CAPACITORS		
C1401		CEJA100M16
RESISTORS		
All Resistors		RD1/6PM□□□J
VR UNIT		
RESISTORS		
VR2102		RCV1102
VR2101		RCV1103
REC SWITCH UNIT		
SWITCHES		
S3		RSG-143
TAPE SELECTOR UNIT		
SWITCHES		
S1, S2		RSH-070
CONNECTOR UNIT		
CAPACITORS		
C1		CKCYF473Z50
RESISTORS		
ALL RESISTORS		RD1/6PM□□□J
SENSOR UNIT (A)		
SEMICONDUCTORS		
D1		GP1A51HR
CAPACITORS		
C2		CKPUYY103N16
RESISTORS		
ALL RESISTORS		RD1/6PM□□□J
SENSOR UNIT (B)		
SEMICONDUCTORS		
D2		GP1A51HR
CAPACITORS		
C3		CKPUYY103N16
RESISTORS		
ALL RESISTORS		RD1/6PM□□□J

Service Manual

ORDER NO.
RRZ1130

The chapter 1 of this Service Manual will not be reprinted. On your additional orders, we may supply only the chapter 2. For the chapter 1, please make copies and attach to the chapter 2 at your side if necessary.

STEREO CASSETTE DECK

CT-S830S

CT-S830S-G

CHAPTER 2

CONTENTS

CHAPTER2

2.1 BLOCK DIAGRAM	2-2
2.2 EXPLODED VIEWS AND PACKING	2-3
2.3 SCHEMATIC DIAGRAMS.....	2-9
2.4 PCB CONNECTION DIAGRAM.....	2-15

PIONEER ELECTRONIC CORPORATION 4-1, Meguro 1-Chome, Meguro-ku, Tokyo 153, Japan

PIONEER ELECTRONICS SERVICE INC. P.O. Box 1760, Long Beach, California 90801 U.S.A.

PIONEER ELECTRONICS OF CANADA, INC. 300 Allstate Parkway Markham, Ontario L3R 0P2 Canada

PIONEER ELECTRONIC [EUROPE] N.V. Haven 1087 Keetberglaan 1, 9120 Melsele, Belgium

PIONEER ELECTRONICS AUSTRALIA PTY. LTD. 178-184 Boundary Road, Braeside, Victoria 3195, Australia TEL: [03] 580-9911

© **PIONEER ELECTRONIC CORPORATION 1994**

T - SSK APR. 1994 Printed in Japan

2.1 BLOCK DIAGRAM

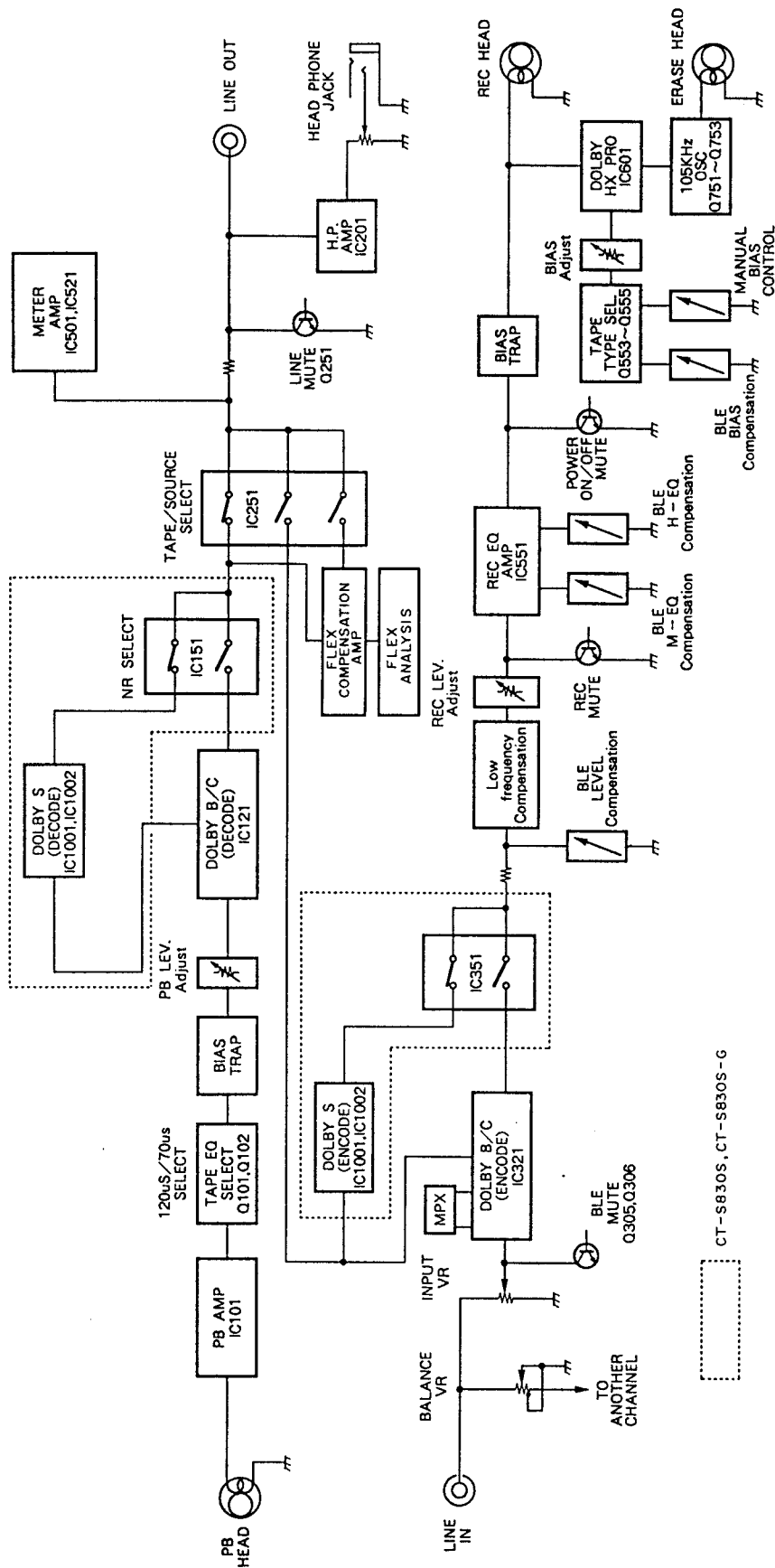

CT-S830S, CT-S830S-G

2.2 EXPLODED VIEWS AND PACKING

1. EXTERIOR

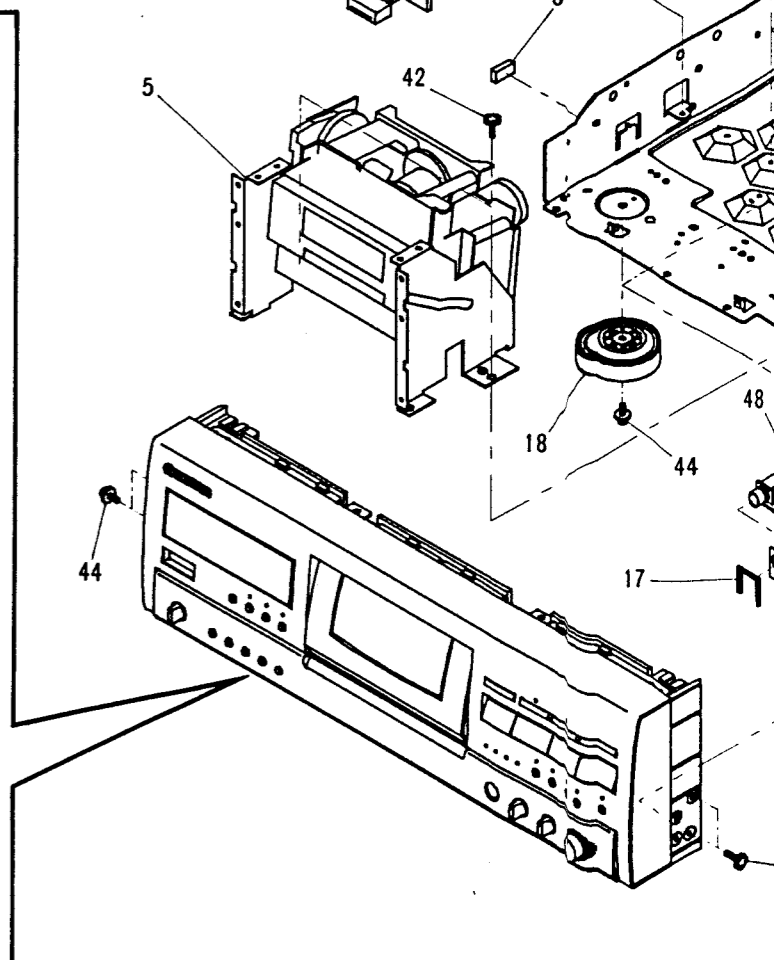
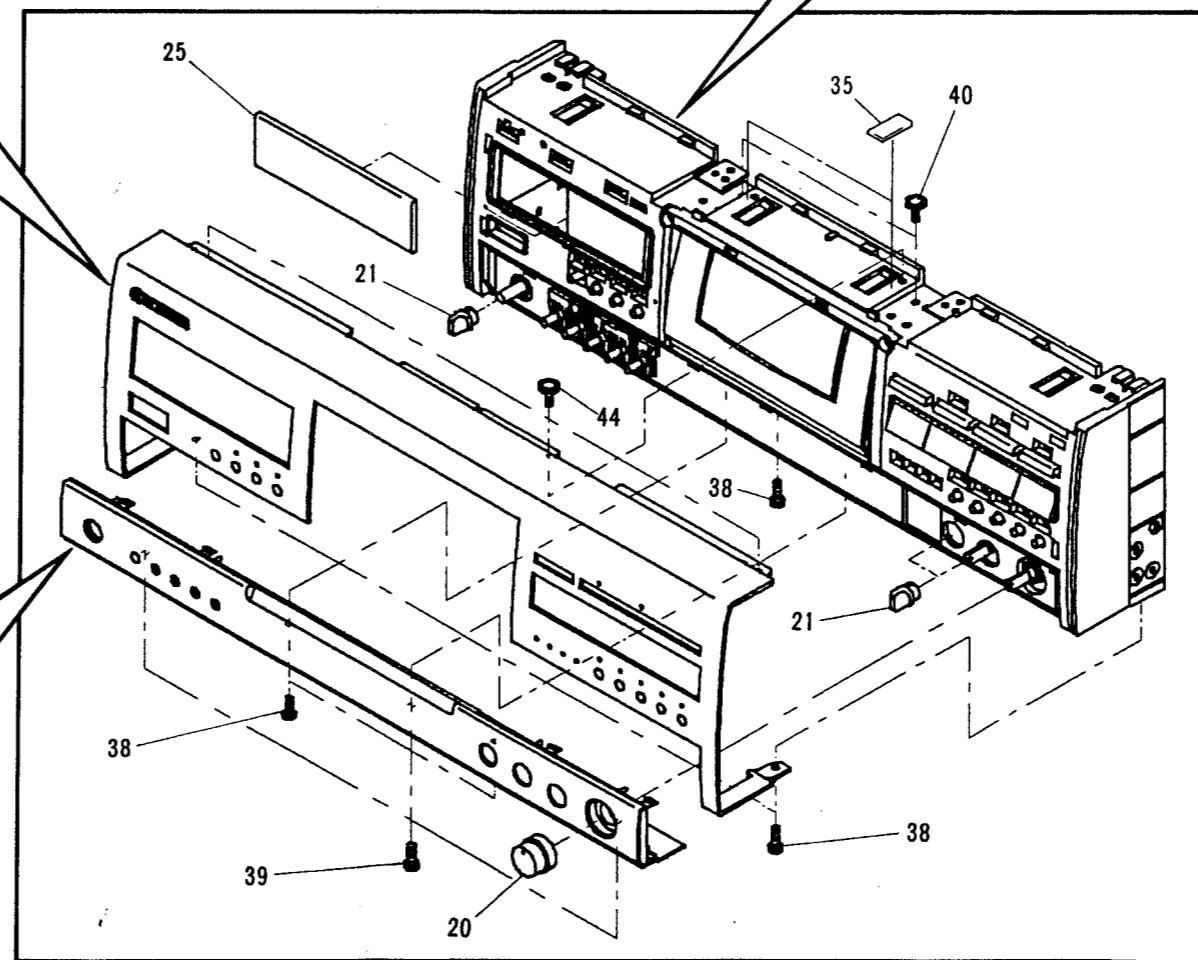
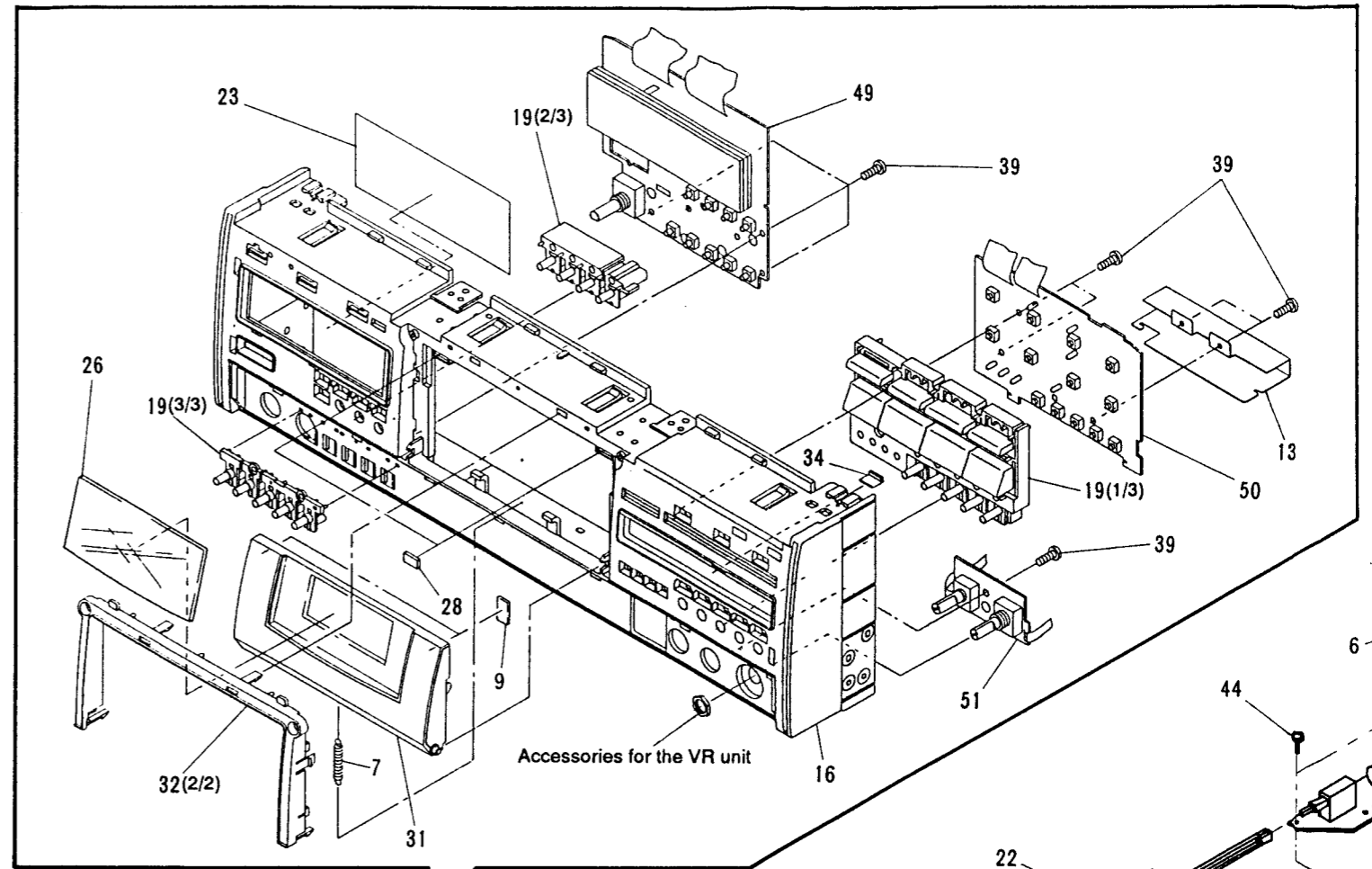
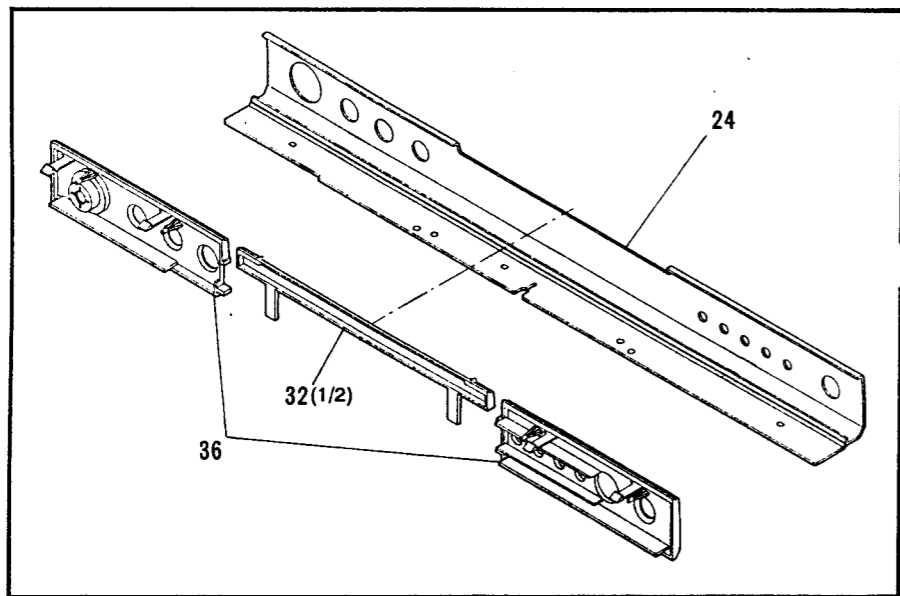
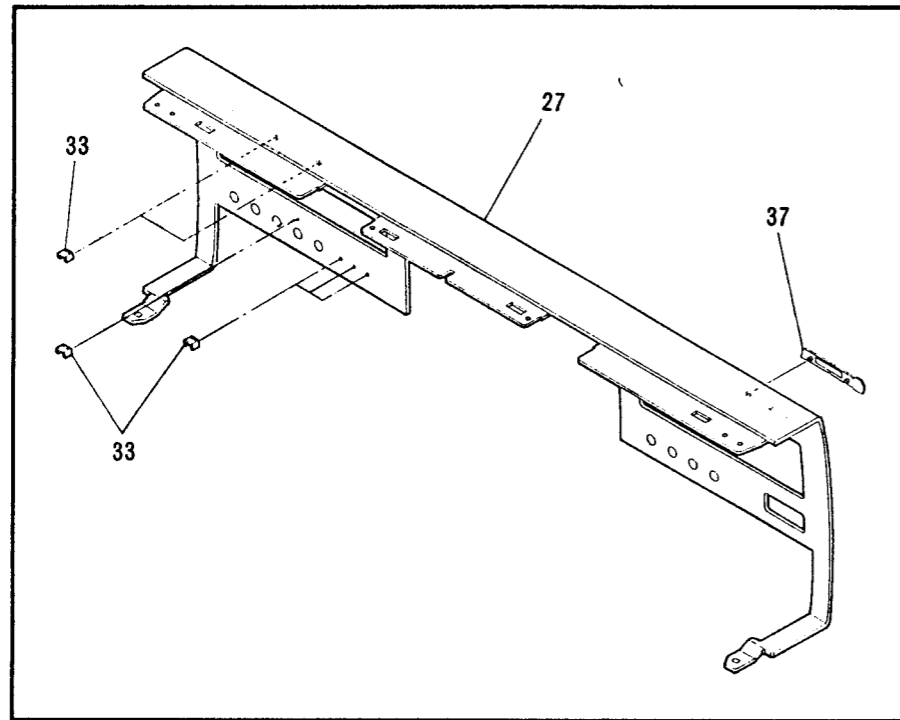
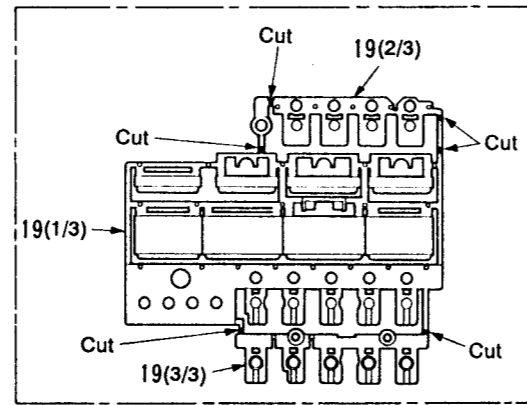
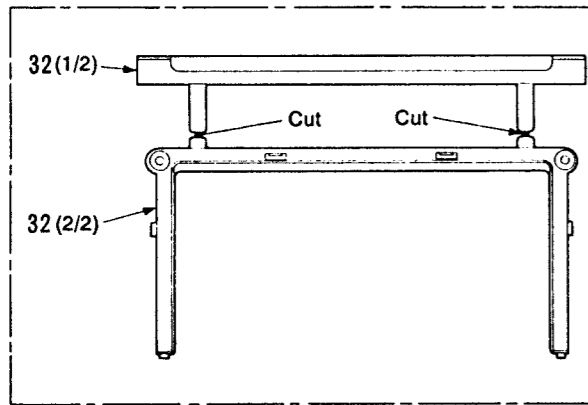

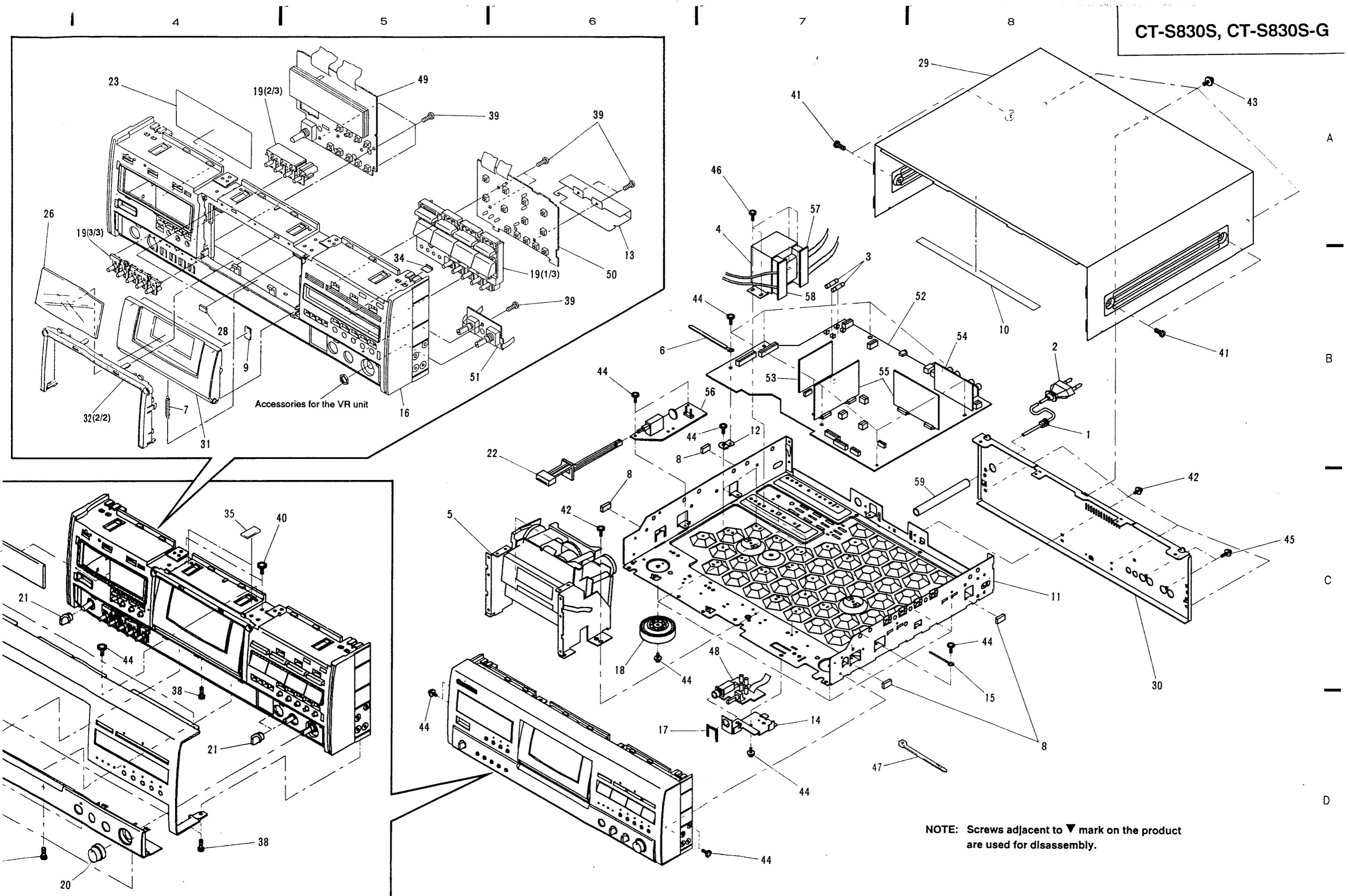

Accessories for the VR unit

NOTE: Screws adjacent to ▼ mark on the product are used for disassembly.

2. MECHANISM UNIT

A

B

C

D

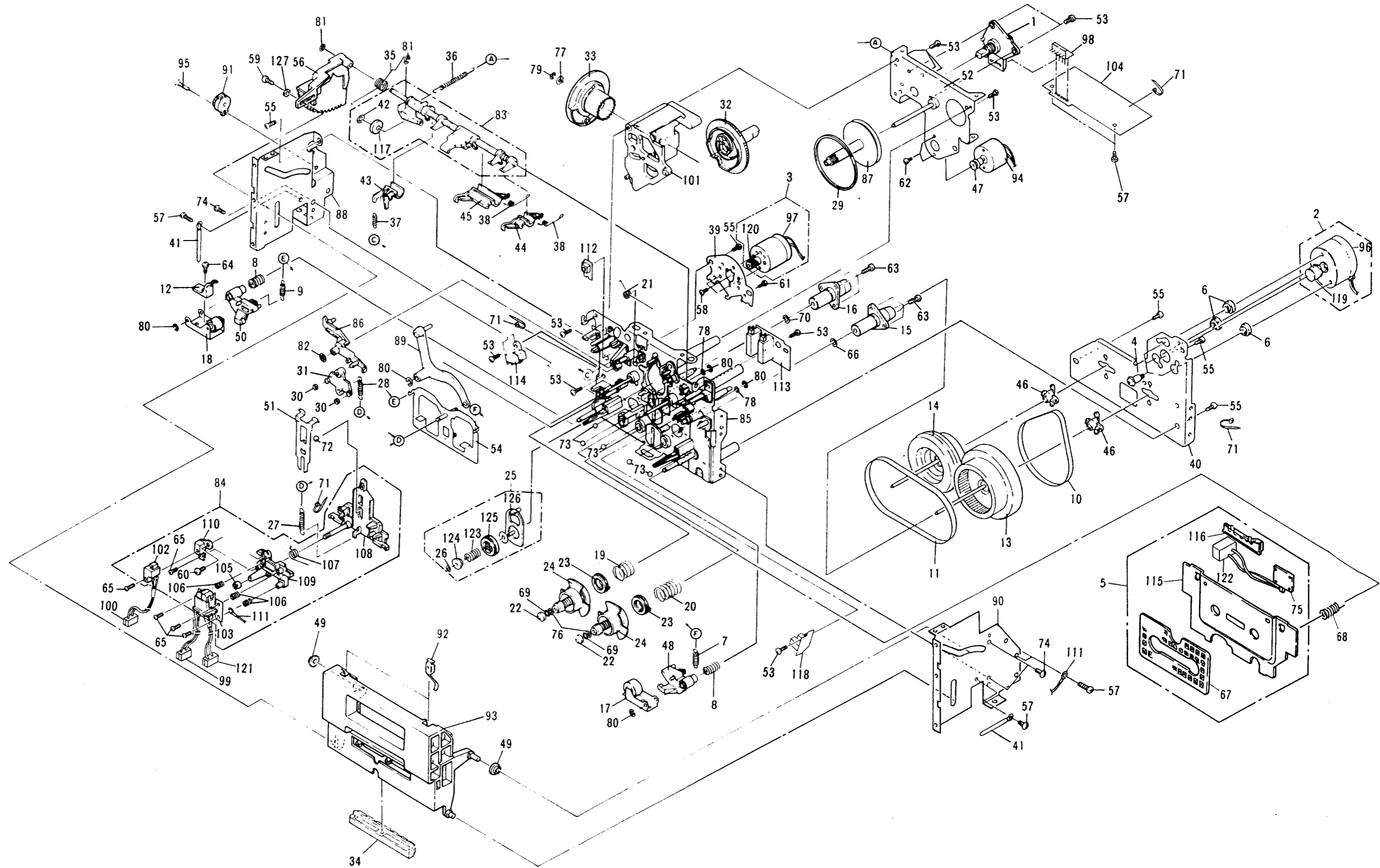

3. PACKING

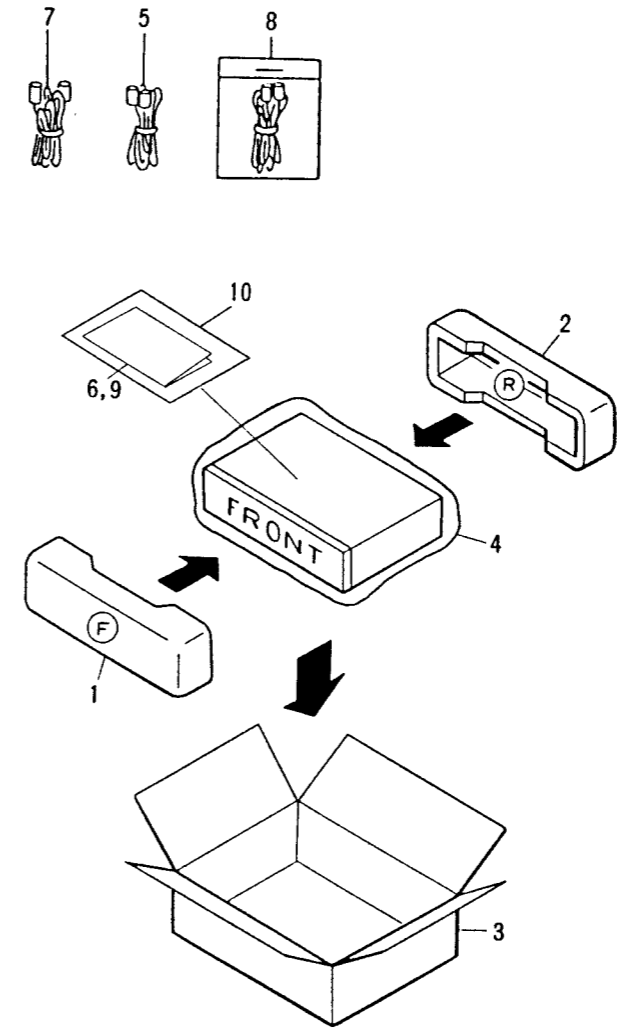
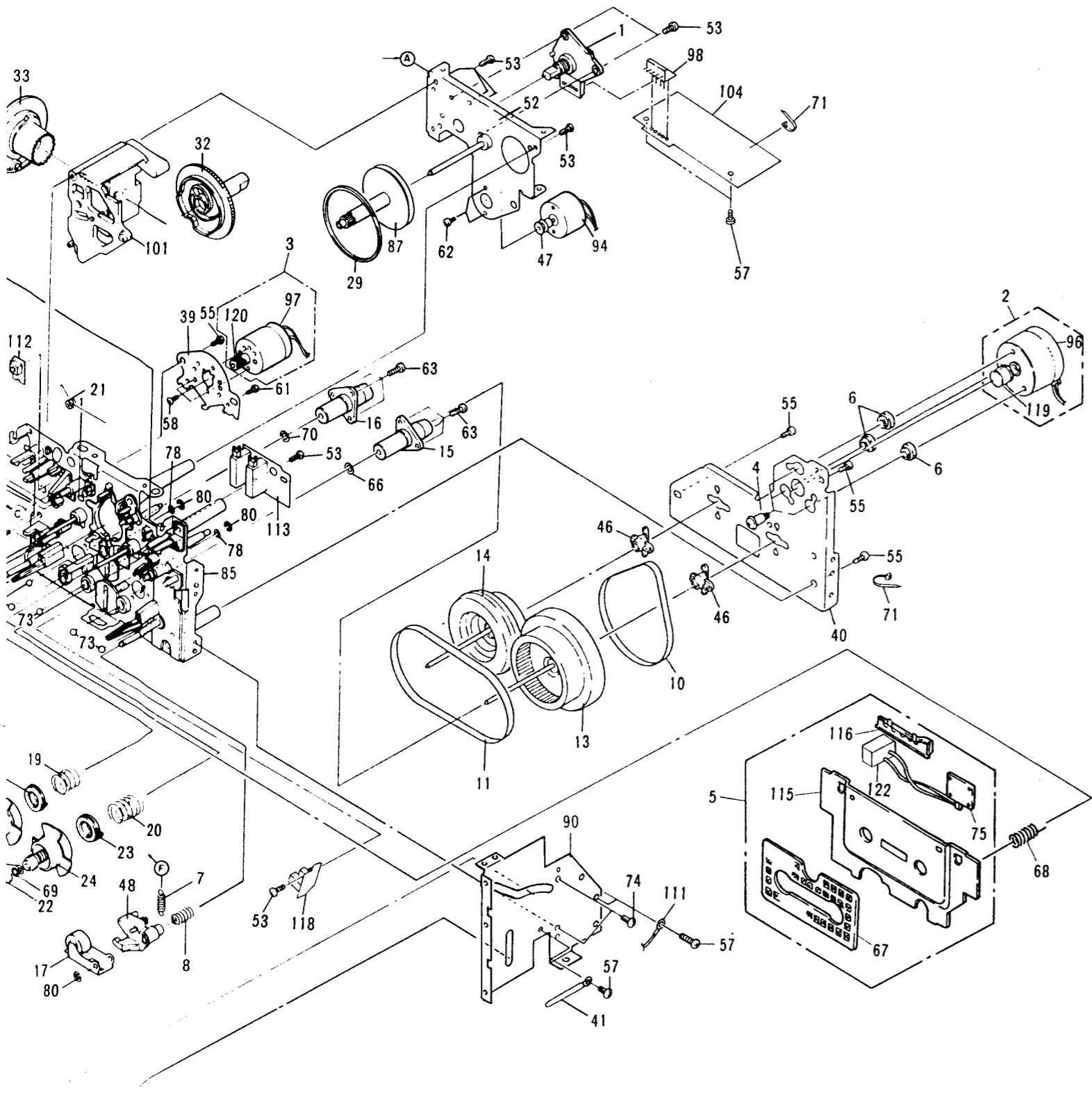

A

B

C

D

2.3 SCHEMATIC DIAGRAMS

NOTE FOR SCHEMATIC DIAGRAMS (Type 6A)

1. When ordering service parts, be sure to refer to "PARTS LIST of EXPLODED VIEWS" or "PCB PARTS LIST".

2. Since these are basic circuits, some parts of them or the values of some components may be changed for improvement.

3. RESISTORS:

Unit: k:Ω, M:ΜΩ, or Ω unless otherwise noted.
 Rated power: 1/4W, 1/6W, 1/8W, 1/10W unless otherwise noted.
 Tolerance: (F): ±1%, (G): ±2%, (K): ±10%, (M): ±20% or ±5% unless otherwise noted.

4. CAPACITORS:

Unit: p:pF or μF unless otherwise noted.
 Ratings: capacitor (μF)/ voltage (V) unless otherwise noted.
 Rated voltage: 50V except for electrolytic capacitors.

5. COILS:

Unit: m:mH or μH unless otherwise noted.

6. VOLTAGE AND CURRENT:

⊖ or - V :
 DC voltage (V) in STOP mode unless otherwise noted.
 mA or - mA :
 DC current in STOP mode unless otherwise noted.

7. OTHERS:

- ⊙ or ⊙ : Adjusting point.
- ⊖ : Measurement point.
- The Δ mark found on some component parts indicates the importance of the safety factor of the parts. Therefore, when replacing, be sure to use parts of identical designation.

8. SCH-□ ON THE SCHEMATIC DIAGRAM:

- SCH-□ indicates the drawing number of the schematic diagram. (SCH stands for schematic diagram.)

9. SWITCHES (Underline indicates switch position):

- OPSW UNIT
- S1401 : ▶PLAY
 - S1402 : ||PAUSE
 - S1403 : CD-SYNCHRO
 - S1404 : MPX FILTER
 - S1405 : ◀REW
 - S1406 : ●REC
 - S1407 : ○MUTE
 - S1408 : DOLBY NR OFF/B/C/S
 - S1409 : ■STOP
 - S1410 : OPEN/CLOSE
 - S1411 : ▶▶FF
 - S1412 : FLEX (1/F)
 - S1413 : MONITOR

- FL UNIT
- S1501 : TAPE RETURN
 - S1502 : BIAS +
 - S1503 : DISPLAY OFF
 - S1504 : METER HOLD
 - S1505 : COUNTER RESET
 - S1506 : BIAS -
 - S1507 : METER MODE
 - S1508 : COUNTER MODE
 - S1509 : AUTO BLE
 - S1511 : TIMER MODE (REC - OFF - PLAY)

1. DOLBY S UNIT

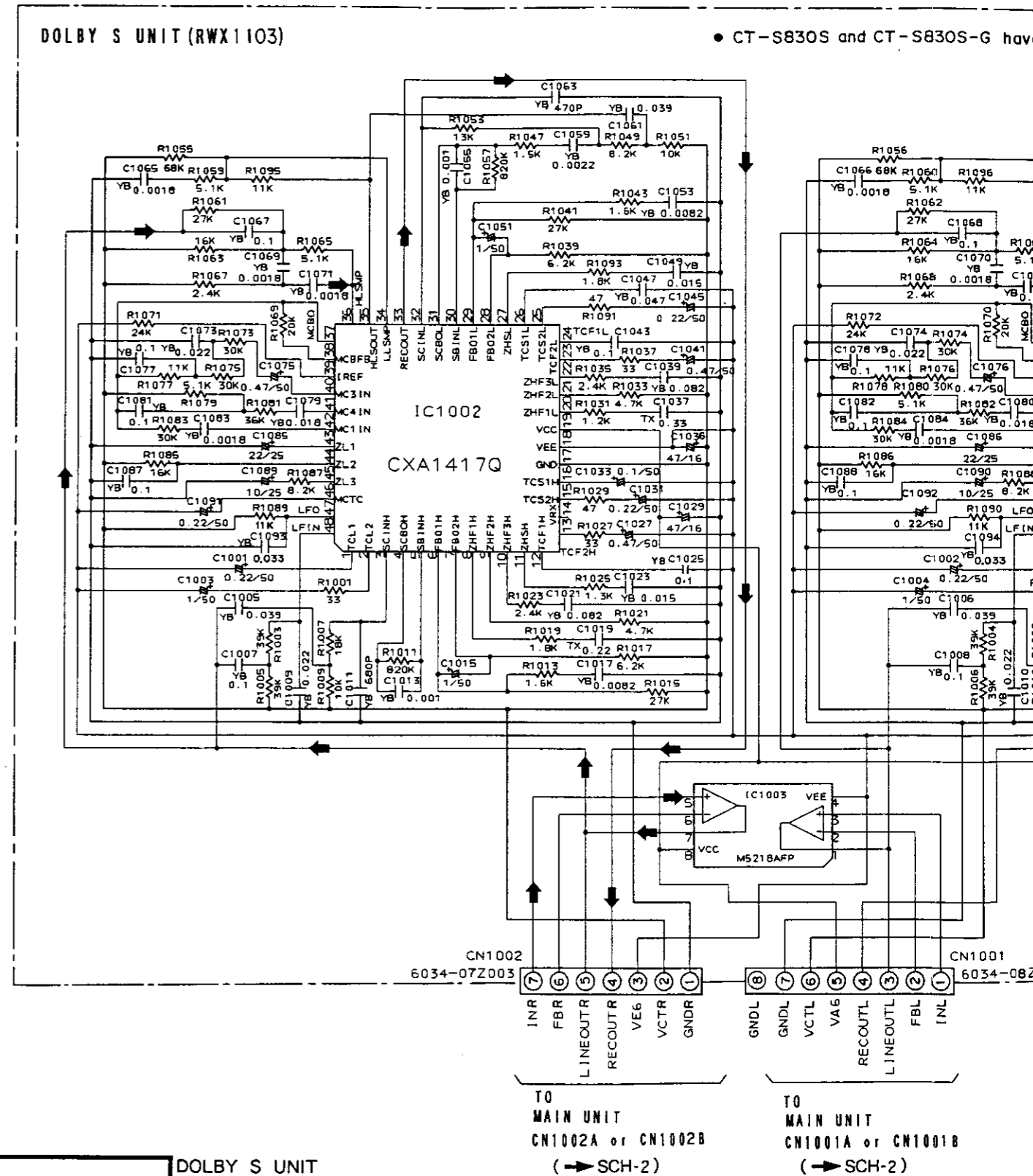

SCH-1 DOLBY S UNIT

1. DOLBY S UNIT

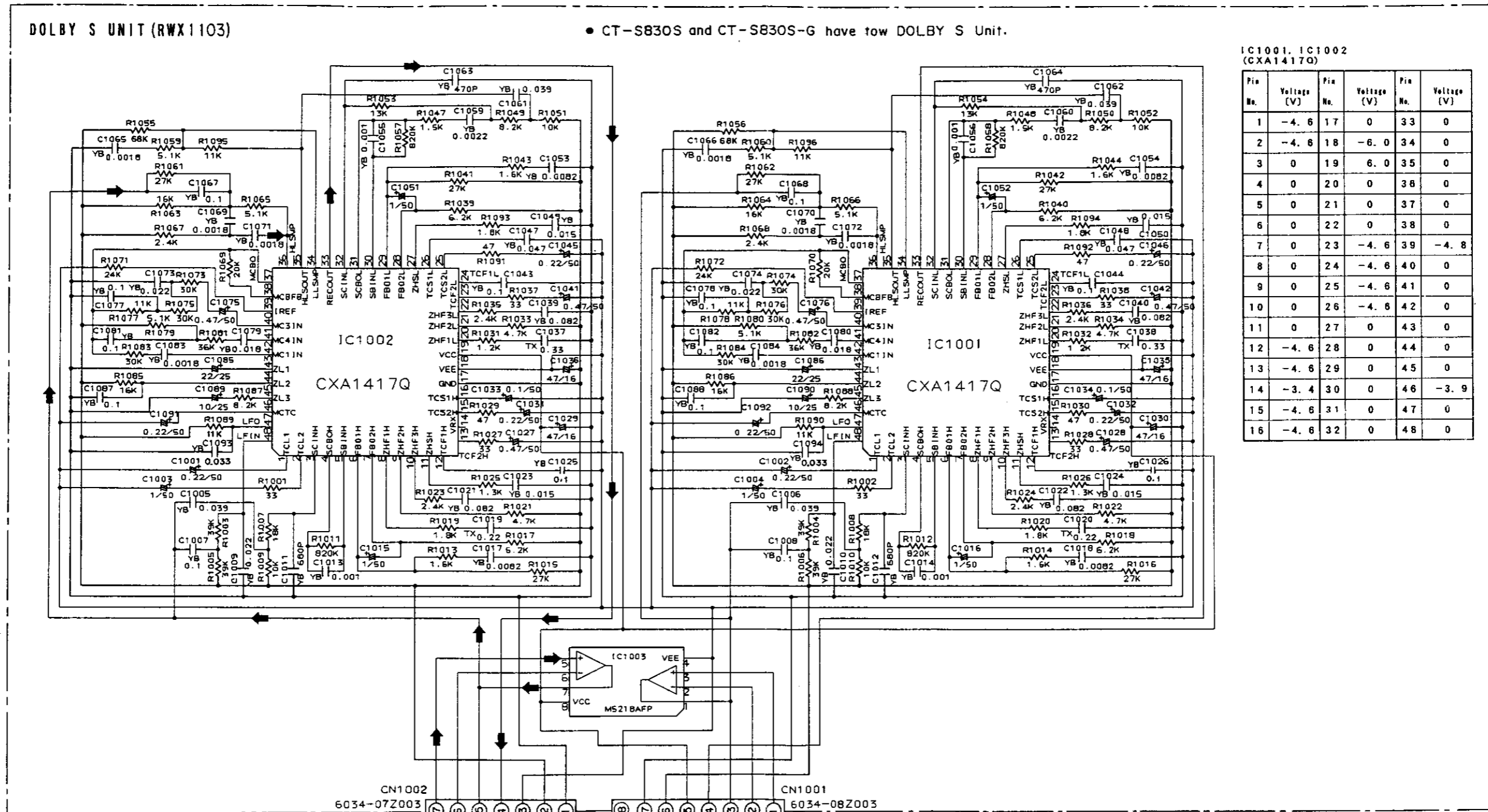

IC1001, IC1002 (CXA1417Q)

Pin No.	Voltage (V)	Pin No.	Voltage (V)	Pin No.	Voltage (V)
1	-4.6	17	0	33	0
2	-4.6	18	-6.0	34	0
3	0	19	6.0	35	0
4	0	20	0	36	0
5	0	21	0	37	0
6	0	22	0	38	0
7	0	23	-4.6	39	-4.8
8	0	24	-4.6	40	0
9	0	25	-4.6	41	0
10	0	26	-4.6	42	0
11	0	27	0	43	0
12	-4.6	28	0	44	0
13	-4.6	29	0	45	0
14	-3.4	30	0	46	-3.9
15	-4.6	31	0	47	0
16	-4.6	32	0	48	0

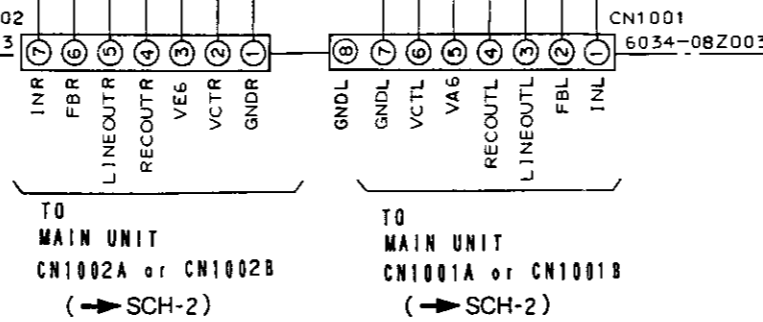

SIGNAL ROUT
 → : ENCODE SIGNAL ROUTE

SCH-1

SCH-1

DOLBY S UNIT

DOLBY S UNIT

SCH-1

2. MAIN, HX, 1/F, PWSW, TRN 2, HPHN, FL, OPSW AND VR UNIT

TO DOLBY S UNIT CN1001 (SCH-1)

A

B

C

D

E

F

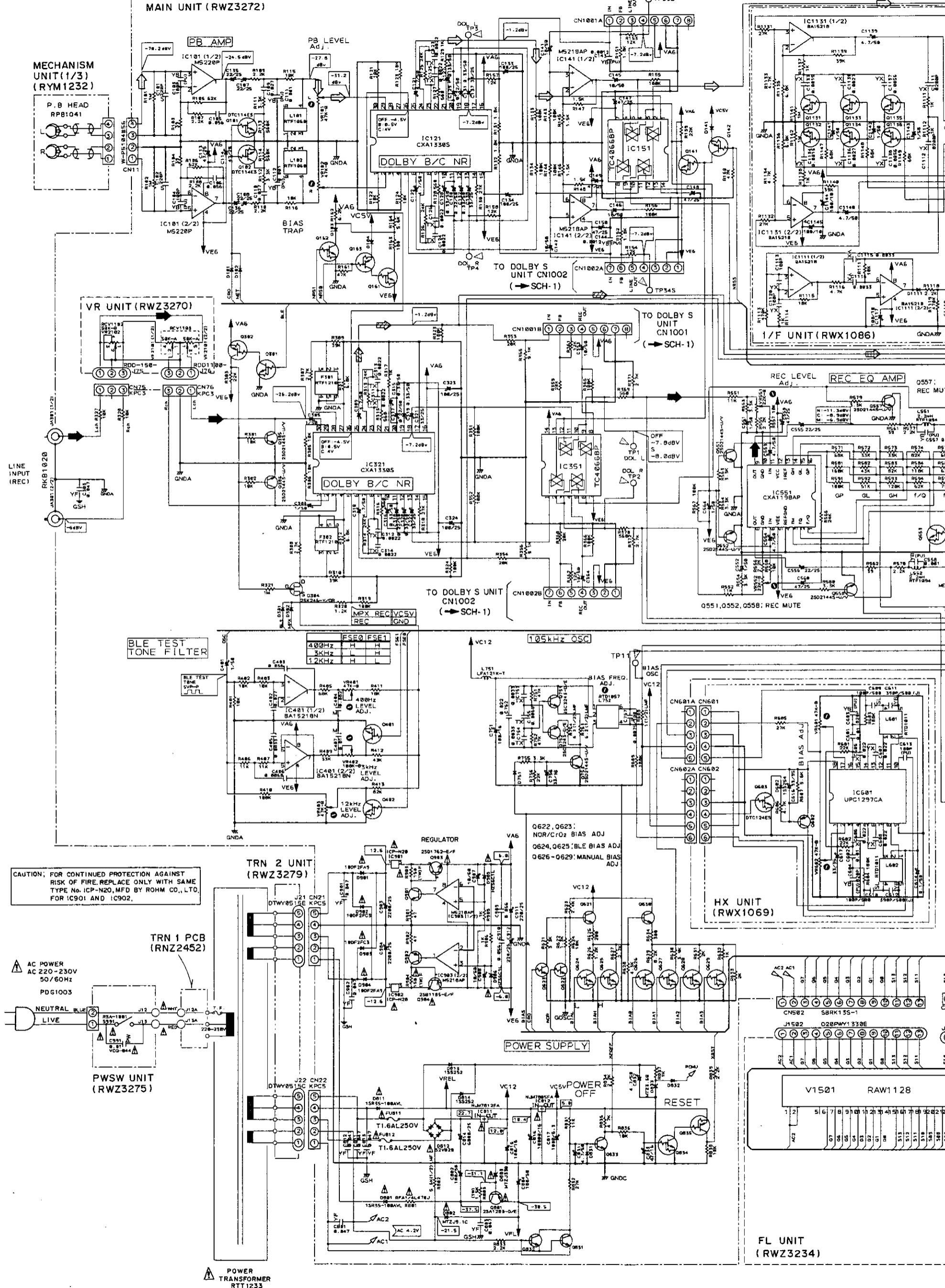

CAUTION: FOR CONTINUED PROTECTION AGAINST RISK OF FIRE, REPLACE ONLY WITH SAME TYPE No. ICP-N20, MFD BY ROHM CO., LTD. FOR IC901 AND IC902.

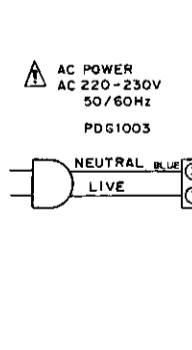

TRN 2 UNIT (RWZ3279)

TRN 1 PCB (RNZ2452)

SCH-2

MAIN UNIT, HX UNIT, 1/F UNIT, PWSW UNIT, TRN 2 UNIT, HPHN UNIT, FL UNIT, OPSW UNIT, VR UNIT

TO DOLBY S UNIT
CN1001 (SCH-1)

LINE
OUTPUT(PLAY)
SKB1020
J4251(1/2) J4251(12/2)

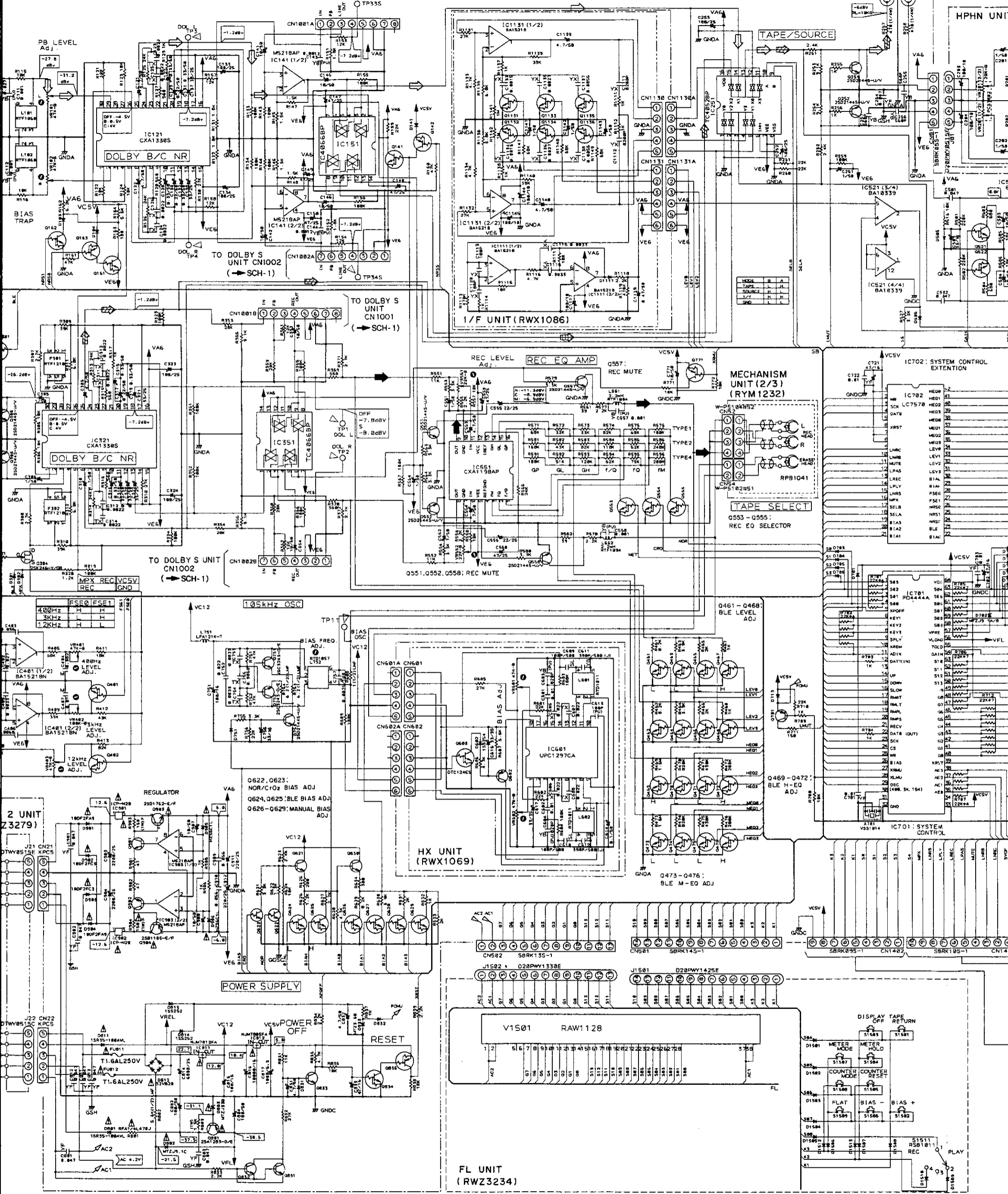

FL UNIT
(RWZ3234)

HPHN UNIT

IC702: SYSTEM CONTROL
EXTENSION

IC701: SYSTEM CONTROL

DISPLAY TAPE RETURN

PLAY

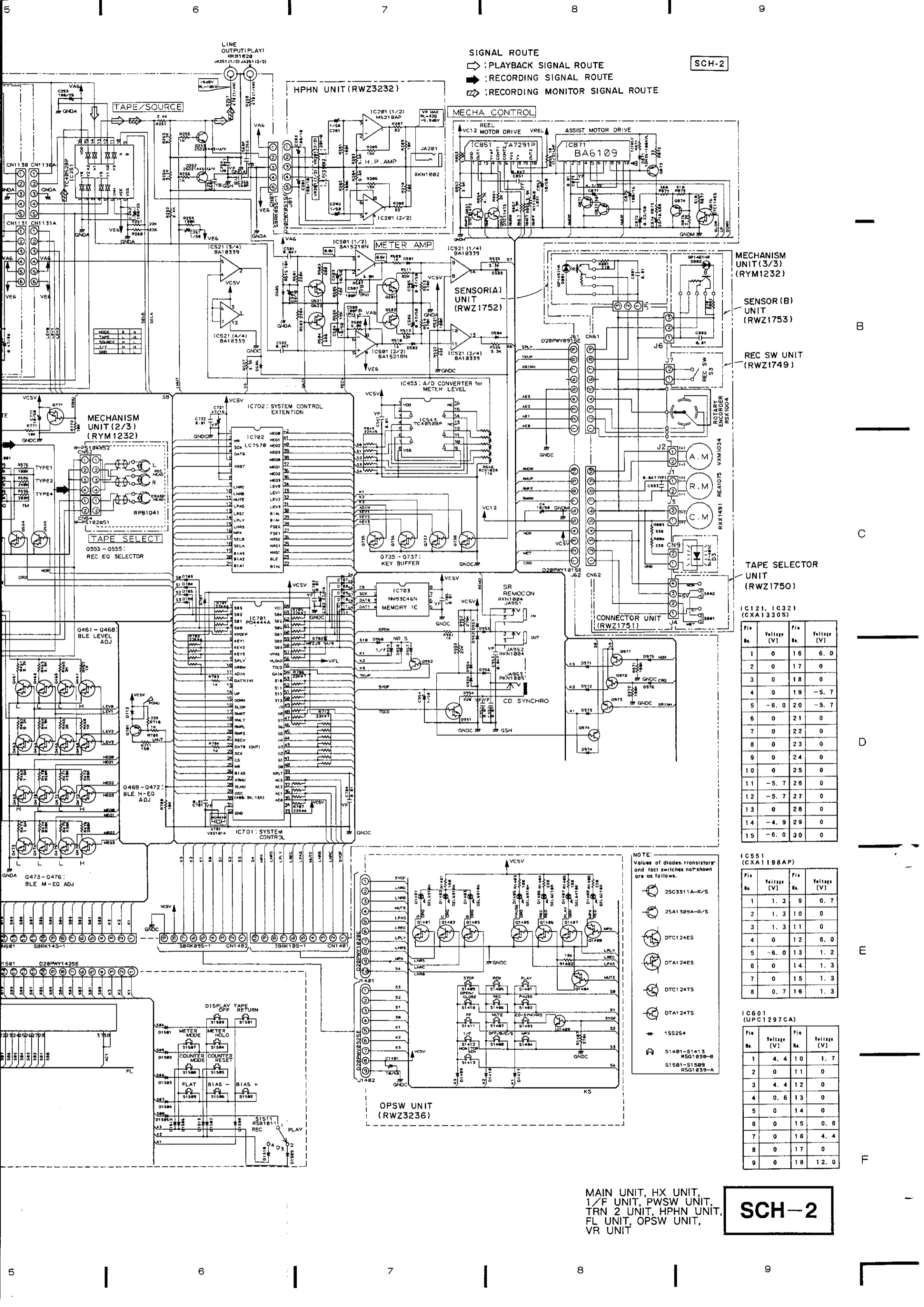

SIGNAL ROUTE
 ⇨ : PLAYBACK SIGNAL ROUTE
 ⇩ : RECORDING SIGNAL ROUTE
 ⇩⇨ : RECORDING MONITOR SIGNAL ROUTE

SCH-2

MECHANISM UNIT (3/3) (RYM1232)

SENSOR (B) UNIT (RWZ1753)

REC SW UNIT (RWZ1749)

TAPE SELECTOR UNIT (RWZ1750)

IC121, IC321 (CXA1330S)

Pin No.	Voltage [V]	Pin No.	Voltage [V]
1	0	16	6.0
2	0	17	0
3	0	18	0
4	0	19	-5.7
5	-6.0	20	-5.7
6	0	21	0
7	0	22	0
8	0	23	0
9	0	24	0
10	0	25	0
11	-5.7	26	0
12	-5.7	27	0
13	0	28	0
14	-4.9	29	0
15	-6.0	30	0

IC551 (CXA1198AP)

Pin No.	Voltage [V]	Pin No.	Voltage [V]
1	1.3	9	0.7
2	1.3	10	0
3	1.3	11	0
4	0	12	6.0
5	-6.0	13	1.2
6	0	14	1.3
7	0	15	1.3
8	0.7	16	1.3

IC601 (UPC1297CA)

Pin No.	Voltage [V]	Pin No.	Voltage [V]
1	4.4	10	1.7
2	0	11	0
3	4.4	12	0
4	0.8	13	0
5	0	14	0
6	0	15	0.6
7	0	16	4.4
8	0	17	0
9	0	18	12.0

- NOTE:
 Values of diodes, transistors and tact switches not shown are as follows.
- 2SC331A-R/S
 - 2SA1309A-R/S
 - DTC124ES
 - DTA124ES
 - DTC124TS
 - DTA124TS
 - 1SS254
 - S1401-S1413 RSG1030-B
 - S1501-S1509 RSG1039-A

MAIN UNIT, HX UNIT, 1/F UNIT, PWSW UNIT, TRN 2 UNIT, HPHN UNIT, FL UNIT, OPWS UNIT, VR UNIT

SCH-2

2.4 PCB CONNECTION DIAGRAM

• This diagram is viewed from the mounted parts side.

NOTE FOR PCB DIAGRAMS:

1. Part numbers in PCB diagrams match those in the schematic diagrams.
2. A comparison between the main parts of PCB and schematic diagrams is shown below.

Symbol in PCB Diagrams	Symbol in Schematic Diagrams	Part Name
		Transistor
		Diode
		Capacitor (Polarized)

3. The transistor terminal marked with E or \square shows the emitter.
4. The diode terminal marked with \ominus or \square shows cathode side.
5. The capacitor terminal marked with \ominus or \square shows negative terminal.

NOTE FOR PCB DIAGRAMS:

1. Part numbers in PCB diagrams match those in the schematic diagrams.
2. A comparison between the main parts of PCB and schematic diagrams is shown below.

Symbol in PCB Diagrams	Symbol in Schematic Diagrams	Part Name
		Transistor
		Transistor with resistor
		Field effect transistor
		Resistor array
		3-terminal regulator

Line Voltage Selection

- Line voltage can be changed by the following modification:
1. Disconnect the AC power cord.
 2. Remove the cover.
 3. Change the connection of TRN 1 PCB primary pins.

Voltage	Terminal No. of TRN 1 PCB
220V - 230V	①
230V - 240V	②

4. Stick the line voltage label on the rear panel.

Parts No.	Description
AAX - 193	220V label
AAX - 192	240V label

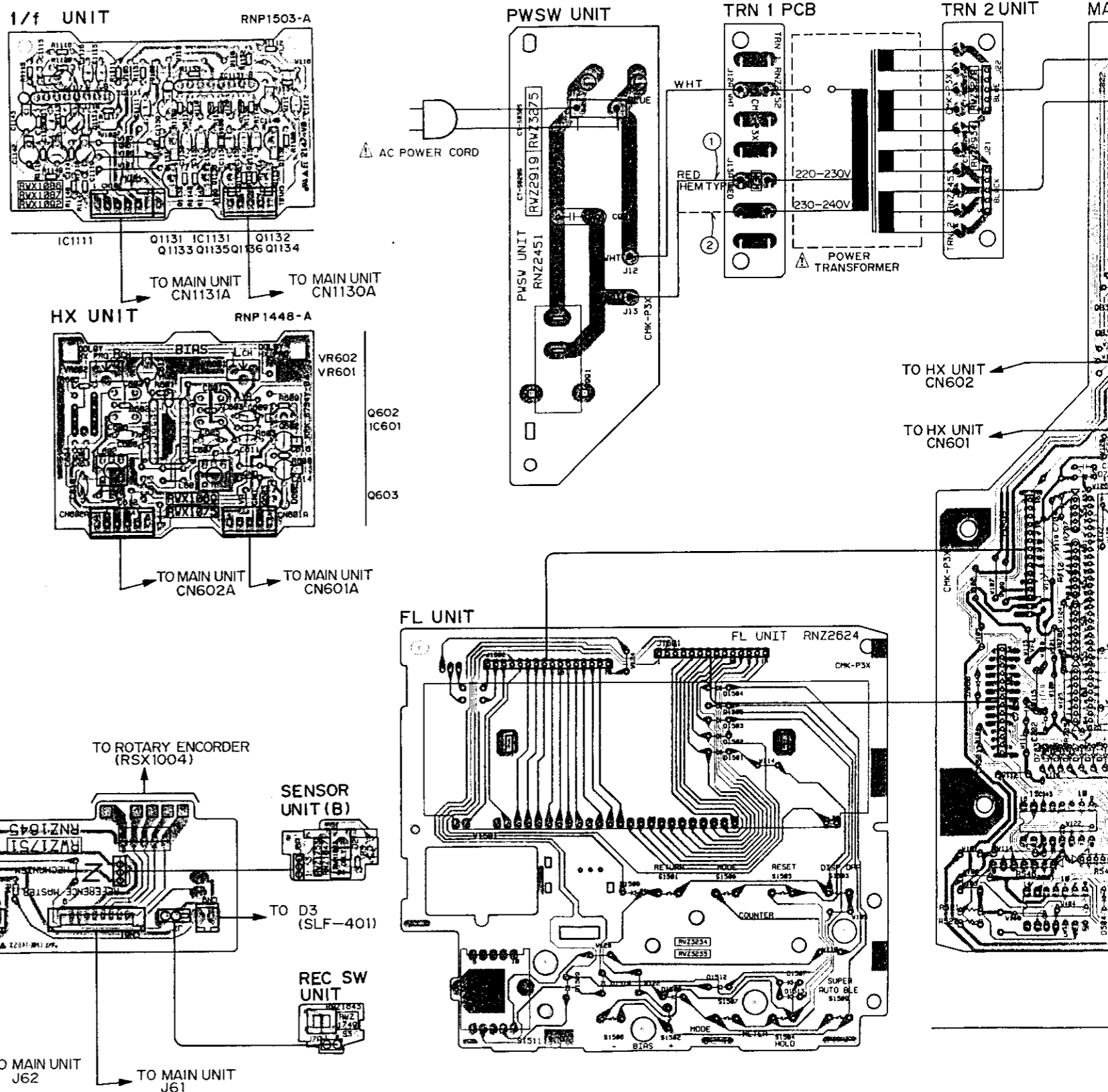

IC543
IC521

- This diagram is viewed from the pink colored foil side.
- This PCB is double sided.

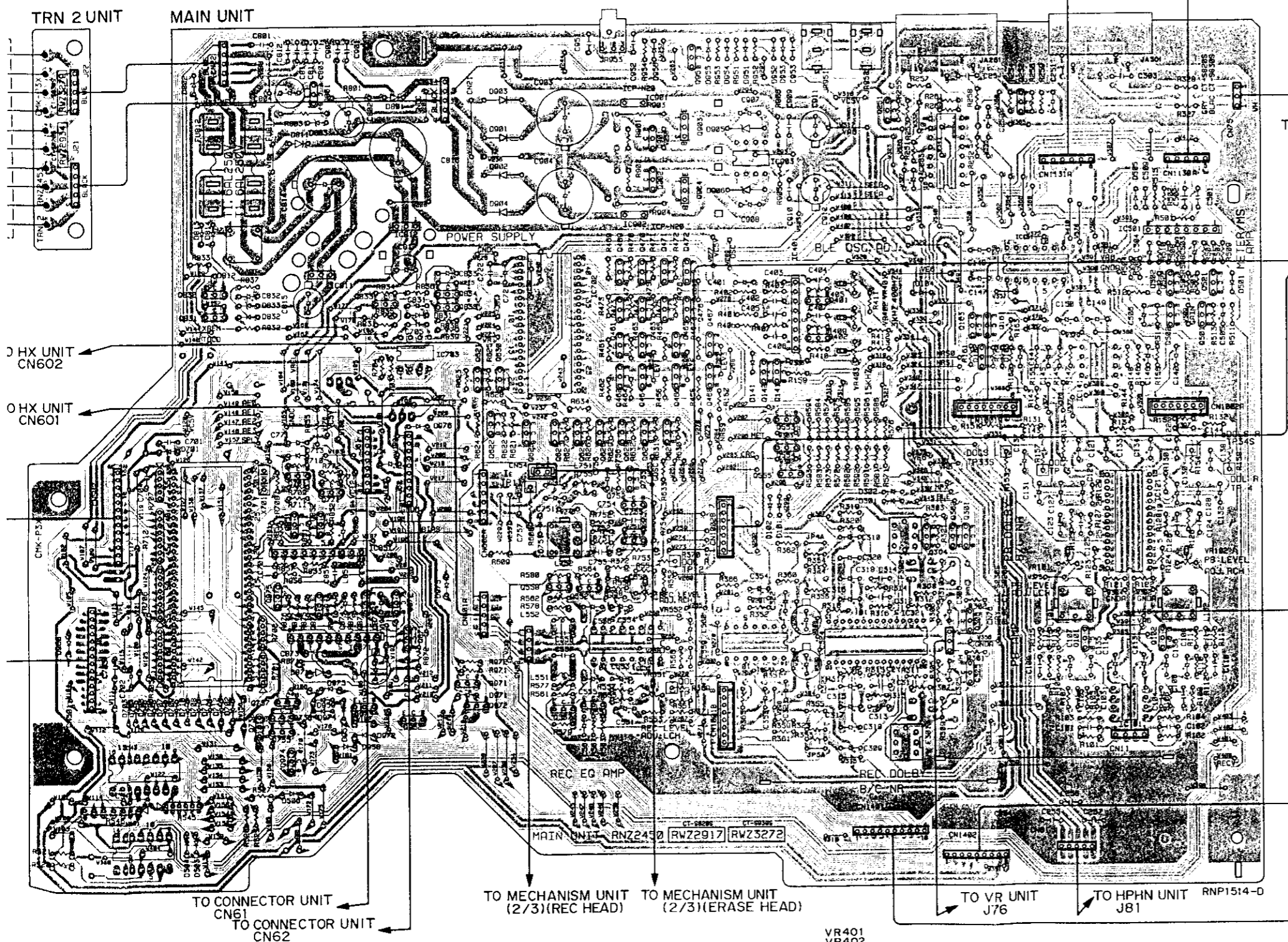

DOLBY S UNIT

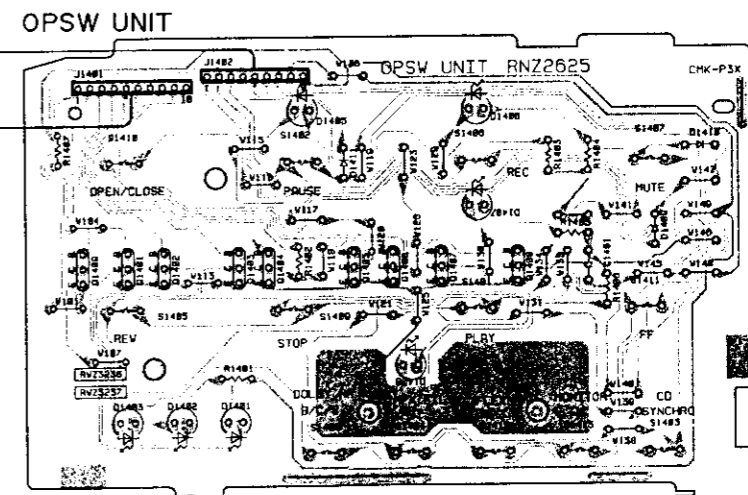
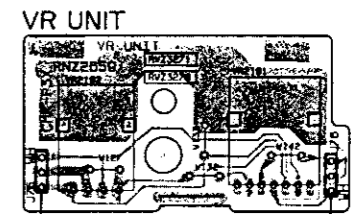
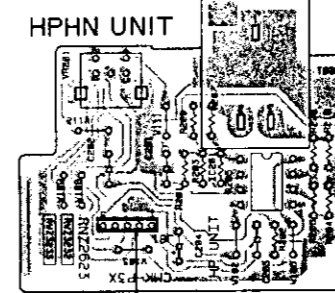
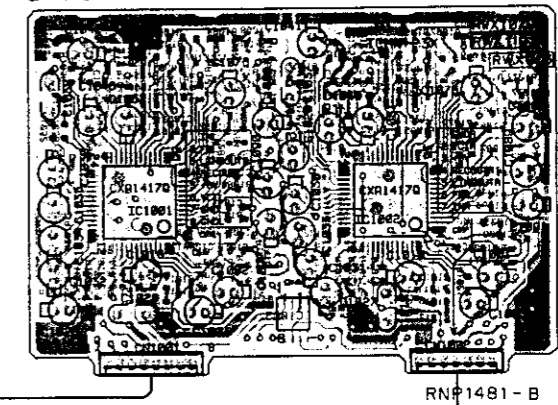

A
B
C
D

Q832	Q801	IC811	IC812	IC901	Q901	Q951	IC903	Q251	IC251	Q252	IC151	IC141	Q522	Q521
Q831	Q701	Q771	Q833	Q834	Q835	IC702	IC401	Q142	Q141	Q401	Q163	Q161	Q502	Q501
IC701	Q851	Q852	IC703	Q621	Q630	Q622	Q623	Q625	Q624	Q626	Q627	Q629	Q627	Q304
IC851	Q875	Q874	Q873	Q872	Q973	Q871	Q971	Q972	Q558	Q552	Q753	Q752	Q554	Q306
IC543	Q737	IC871	Q971	Q972	Q557	Q551	IC351	Q555	IC321	Q305	Q101	IC121	Q102	IC101
IC521	Q738	Q736	Q735	Q974										

- This diagram is viewed from the gray colored foil side.
- This PCB is double sided.

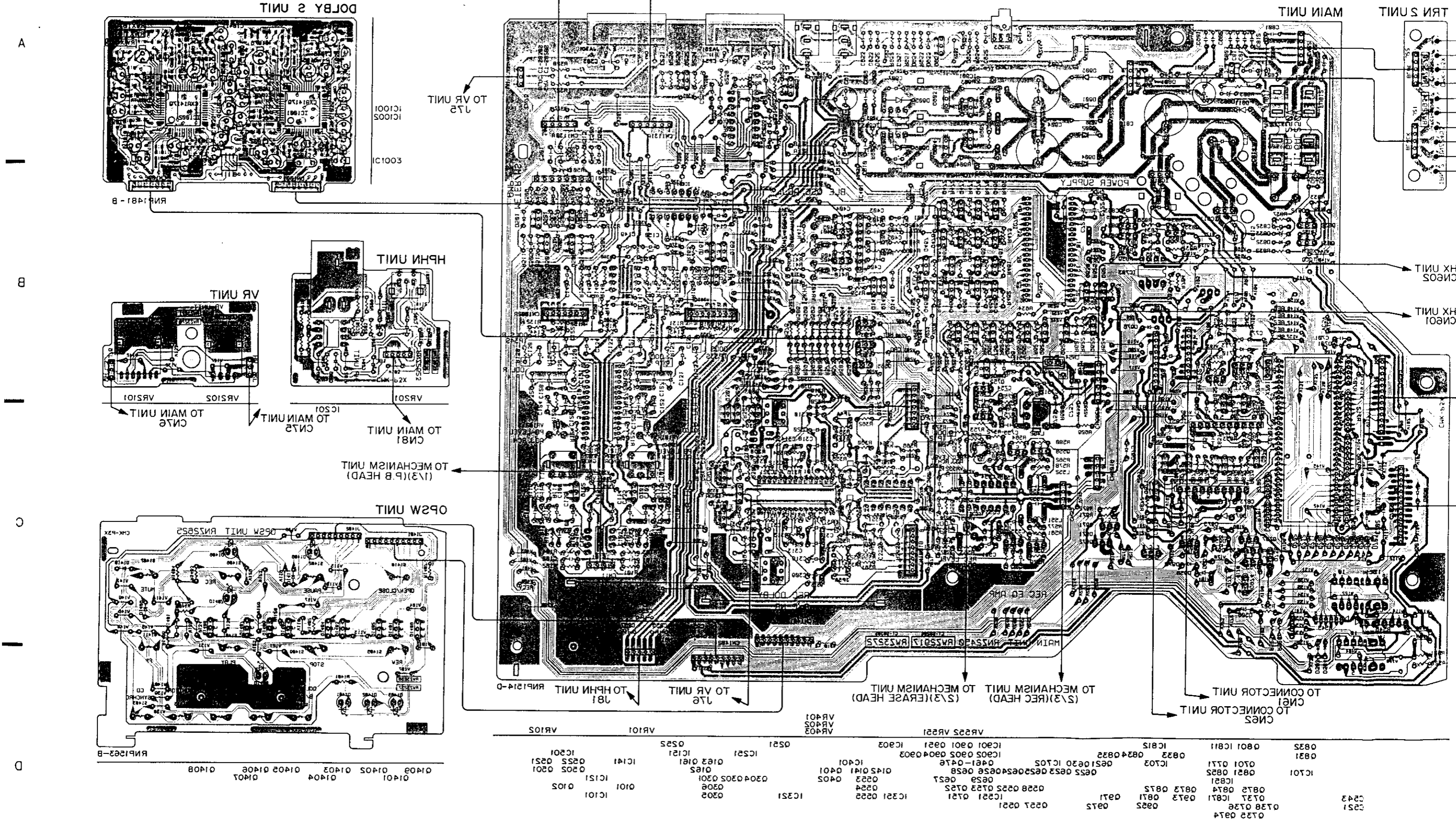

2.4 PCB CONNECTION DIAGRAM

• This diagram is viewed from the foil side.

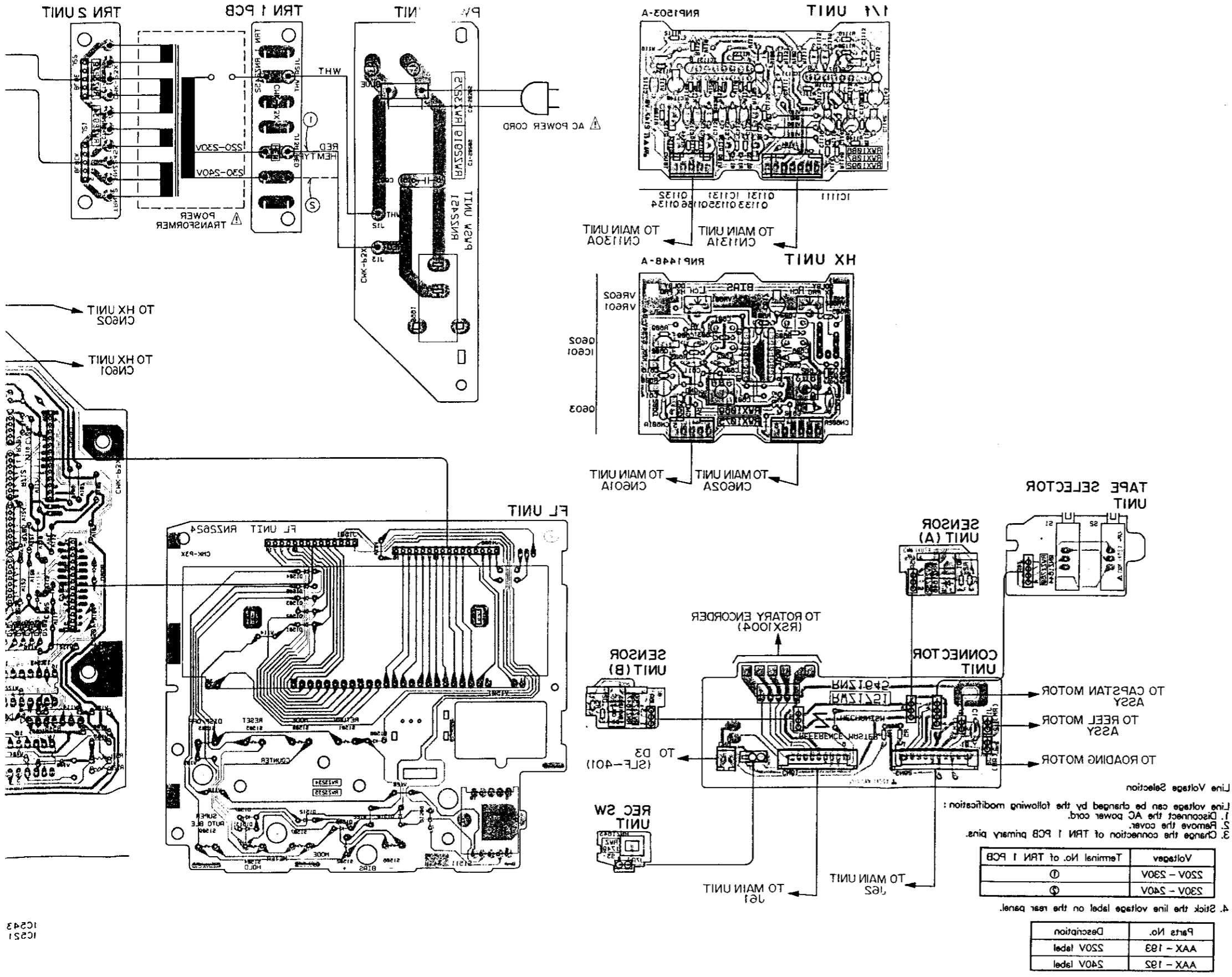

A
B
C
D

a

b

4

3

5

1

e

2

4

3

5

1

1C251
1C242