

Service Manual

 **PIONEER®**
The Art of Entertainment

ORDER NO.
ARP2483

STEREO CASSETTE DECK

CT-S710 HEM
CT-S710-G HEM

- Refer to the service manual ARP2482 for CT-S910.
- This manual is applicable to CT-S710/HEM and CT-S710-G/HEM.

PIONEER ELECTRONIC CORPORATION 4-1, Meguro 1-Chome, Meguro-ku, Tokyo 153, Japan
PIONEER ELECTRONICS SERVICE INC. P.O. Box 1760, Long Beach, California 90801 U.S.A.
PIONEER ELECTRONICS OF CANADA, INC. 300 Allstate Parkway Markham, Ontario L3R 0P2 Canada
PIONEER ELECTRONIC [EUROPE] N.V. Haven 1087 Keetberglaan 1, 9120 Melsele, Belgium
PIONEER ELECTRONICS AUSTRALIA PTY. LTD. 178-184 Boundary Road, Braeside, Victoria 3195, Australia TEL: [03] 580-9911
© **PIONEER ELECTRONIC CORPORATION 1992**

SN APR. 1992 Printed in Japan

CT-S710, CT-S710-G

CONTRAST OF MISCELLANEOUS PARTS

NOTES:

- Parts without part number cannot be supplied.
- The Δ mark found on some component parts indicates the importance of the safety factor of the part. Therefore, when replacing, be sure to use parts of identical designation.
- Parts marked by "⊙" are not always kept in stock. Their delivery time may be longer than usual or they may be unavailable.

CT-S710/HEM, CT-S710-G/HEM and CT-S910/HEM have the same construction except for the following:

Mark	Symbol & Description	Part No.			Remarks
		CT-S910/ HEM type	CT-S710/ HEM type	CT-S710-G/ HEM type	
	CONTROL unit	Non supply	Non supply	Non supply	
	BALANCE VR unit	Non supply	Non supply	Non supply	
	FL unit	Non supply	Non supply	Non supply	
	FUNCTION unit	Non supply	Non supply	Non supply	
	BIAS unit	Non supply	Non supply	Non supply	
	HEADPHONE unit	Non supply	Non supply	Non supply	
	VR unit	Non supply	Non supply	
	MAIN unit	Non supply	Non supply	Non supply	
⊙	Mechanism unit	RYM1152	RYM1161	RYM1161	
⚠	AC power cord	ADG1036	PDG1003	PDG1003	
⚠	Power transformer	RTT1201	RTT1202	RTT1202	
	VR ring	RAT1011	RAT1011	RAT1010	
	VR knob	RAC1707	RAC1708	
	FL lens	RAH2019	RAH2032	RAH2032	
	Function knob	RAC1704	RAC1706	RAC1711	
	Slide SW knob	RAC1562	RAC1562	RAC1540	
	Balance knob	RAC1705	RAC1705	RAC1662	
	Power button	RAC1703	RAC1703	RAC1657	
	Packing case	RHG1356	RHG1357	RHG1358	
	Panel stay	RNT1139	RNT1140	RNT1141	
	Washer	ABE1009	
	Washer	RBF1019	
	Cord with mini plug	PDE-319	PDE-319	
	VR knob assembly	RXA1472	
	Bonnet	RXX1505	RXX1516	RXX1506	
	Door assembly	RXX1514	
	Front panel assembly	RXX1510	RXX1511	RXX1512	

MECHANISM Unit

Mechanism Unit RYM1161 and RYM1152 have the same construction except for the following:

Mark	Symbol & Description	Part No.		Remarks
		RYM1152	RYM1161	
	Screw	RBA1074	RBA-064	
	Spring	RBH1226	
	Belt	REB-501	REB1143	
	Insulator	REB1099	
	Rubber cushion	REB1125	
	Motor bracket	RNK1497	
	Capstan motor assembly	RXM1016	RXX1491	
	Capstan motor	RXM1054	
	Head base assembly	RXX1443	RXX1523	

CT-S710, CT-S710-G

CONTRAST OF MISCELLANEOUS PARTS

NOTES:

- Parts without part number cannot be supplied.
- The Δ mark found on some component parts indicates the importance of the safety factor of the part. Therefore, when replacing, be sure to use parts of identical designation.
- Parts marked by "⊙" are not always kept in stock. Their delivery time may be longer than usual or they may be unavailable.

CT-S710/HEM, CT-S710-G/HEM and CT-S910/HEM have the same construction except for the following:

Mark	Symbol & Description	Part No.			Remarks
		CT-S910/ HEM type	CT-S710/ HEM type	CT-S710-G/ HEM type	
	CONTROL unit	Non supply	Non supply	Non supply	
	BALANCE VR unit	Non supply	Non supply	Non supply	
	FL unit	Non supply	Non supply	Non supply	
	FUNCTION unit	Non supply	Non supply	Non supply	
	BIAS unit	Non supply	Non supply	Non supply	
	HEADPHONE unit	Non supply	Non supply	Non supply	
	VR unit	Non supply	Non supply	
	MAIN unit	Non supply	Non supply	Non supply	
⊙	Mechanism unit	RYM1152	RYM1161	RYM1161	
⚠	AC power cord	ADG1036	PDG1003	PDG1003	
⚠	Power transformer	RTT1201	RTT1202	RTT1202	
	VR ring	RAT1011	RAT1011	RAT1010	
	VR knob	RAC1707	RAC1708	
	FL lens	RAH2019	RAH2032	RAH2032	
	Function knob	RAC1704	RAC1706	RAC1711	
	Slide SW knob	RAC1562	RAC1562	RAC1540	
	Balance knob	RAC1705	RAC1705	RAC1662	
	Power button	RAC1703	RAC1703	RAC1657	
	Packing case	RHG1356	RHG1357	RHG1358	
	Panel stay	RNT1139	RNT1140	RNT1141	
	Washer	ABE1009	
	Washer	RBF1019	
	Cord with mini plug	PDE-319	PDE-319	
	VR knob assembly	RXA1472	
	Bonnet	RXX1505	RXX1516	RXX1506	
	Door assembly	RXX1514	
	Front panel assembly	RXX1510	RXX1511	RXX1512	

MECHANISM Unit

Mechanism Unit RYM1161 and RYM1152 have the same construction except for the following:

Mark	Symbol & Description	Part No.		Remarks
		RYM1152	RYM1161	
	Screw	RBA1074	RBA-064	
	Spring	RBH1226	
	Belt	REB-501	REB1143	
	Insulator	REB1099	
	Rubber cushion	REB1125	
	Motor bracket	RNK1497	
	Capstan motor assembly	RXM1016	RXX1491	
	Capstan motor	RXM1054	
	Head base assembly	RXX1443	RXX1523	

● PCB CONNECTIONS DIAGRAM

A

B

C

D

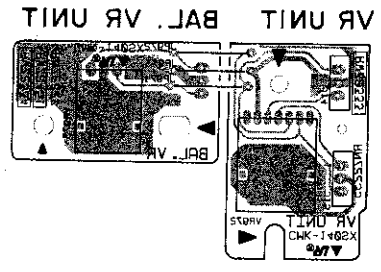

MECHA UNIT (RYM112S)

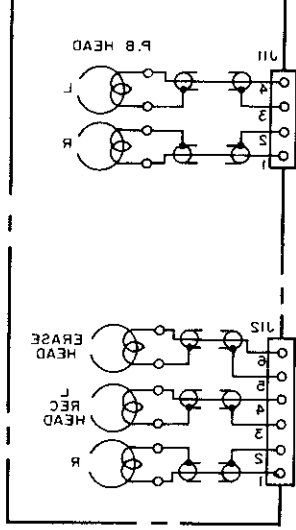

BIAS UNIT

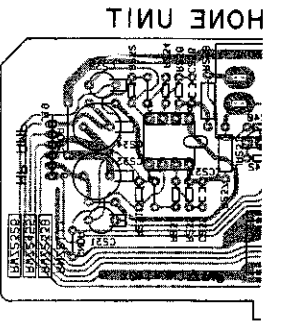
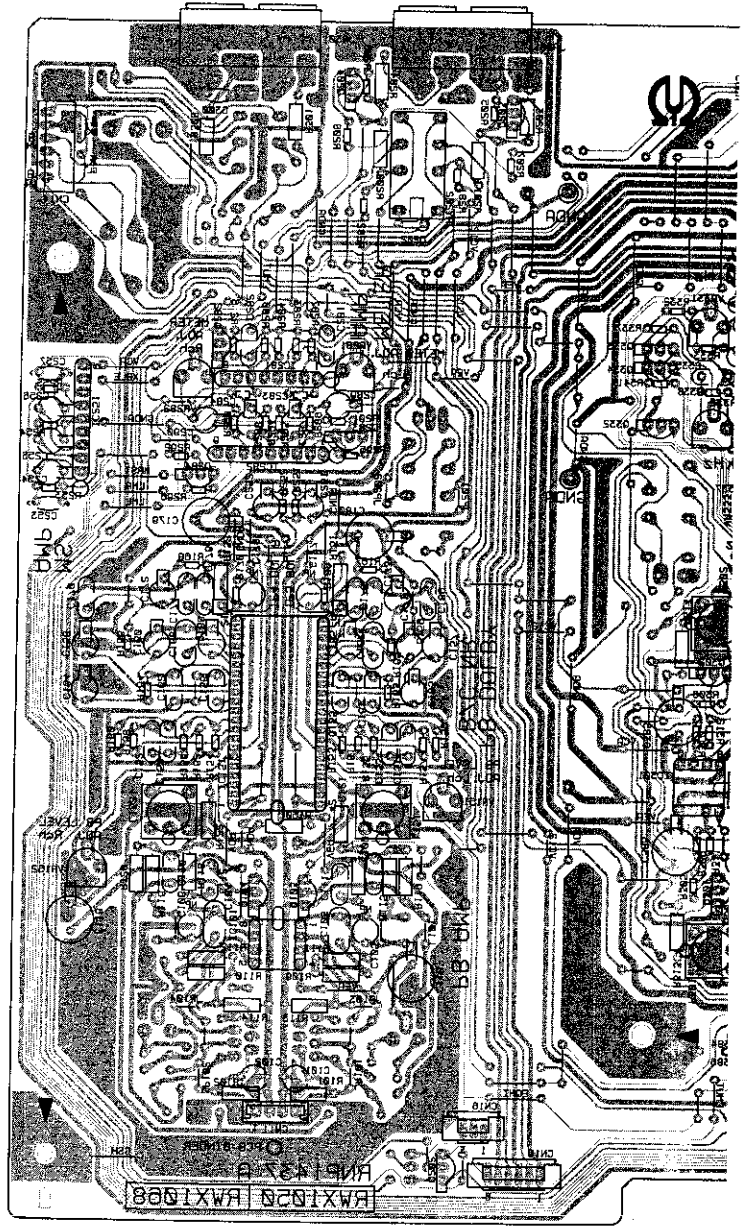
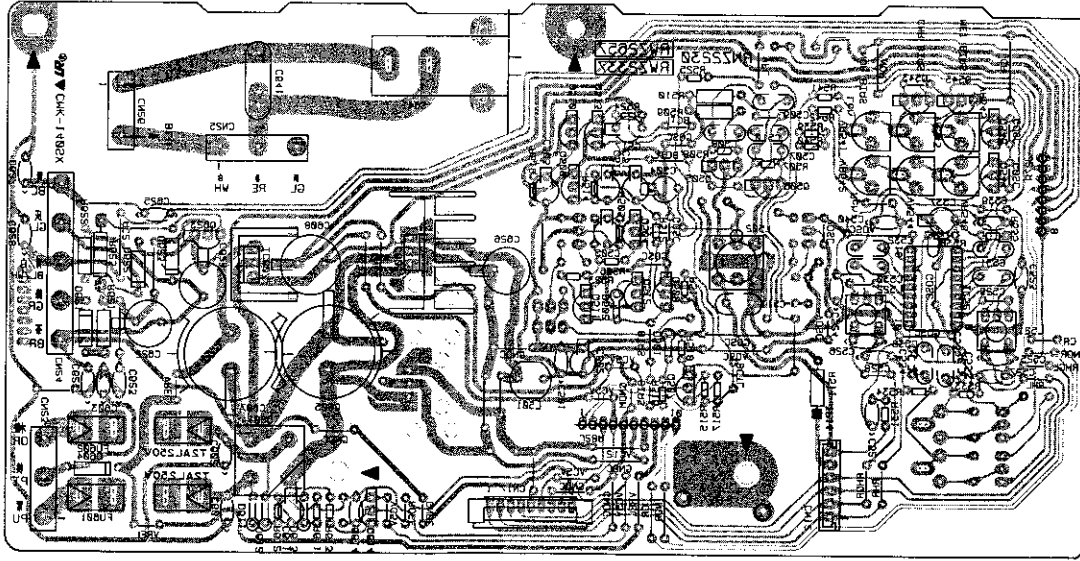

• View from component side

A

CONTROL UNIT

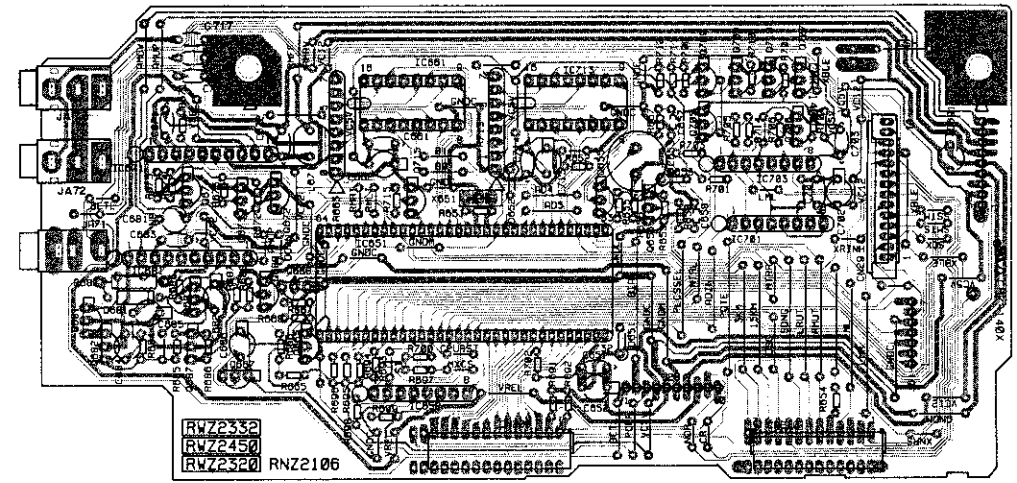

B

FL UNIT

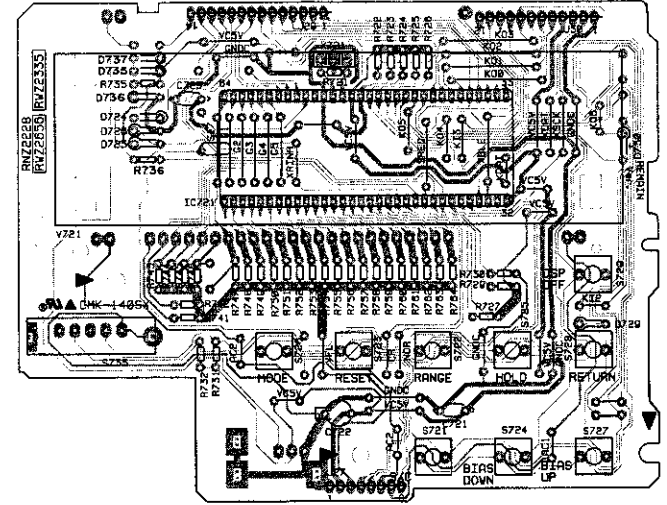

C

MAIN UNIT

- IC551 IC571 0204
- IC561 0203
- VR971
- VR331
- 0333 0282
- IC562 0334 IC281 VR281
- IC331 VR282
- IC552 IC572 0332 IC251 VR332
- 0482 0283
- 0476 0471 IC282
- 0475 0471 0331 0284 VR333
- 0474 0478
- 0473 0479
- 0486
- 0472 0481
- 0460 0428
- 0462 0408
- 0434 0426
- 0442 0406
- 0440 0424
- 0456 0404
- 0422
- 0402 0302
- 0420
- IC151
- IC402 IC401 IC301 VR402
- IC351 VR401
- 0401 0301 0103
- 0419 0104
- 0403
- 0421
- 0455 0405
- 0439 0423
- 0441 0407
- 0461 0429
- 0439 0427
- 0459
- 0384 0101 VR102
- 0385 0102 VR101
- 0386
- 0202

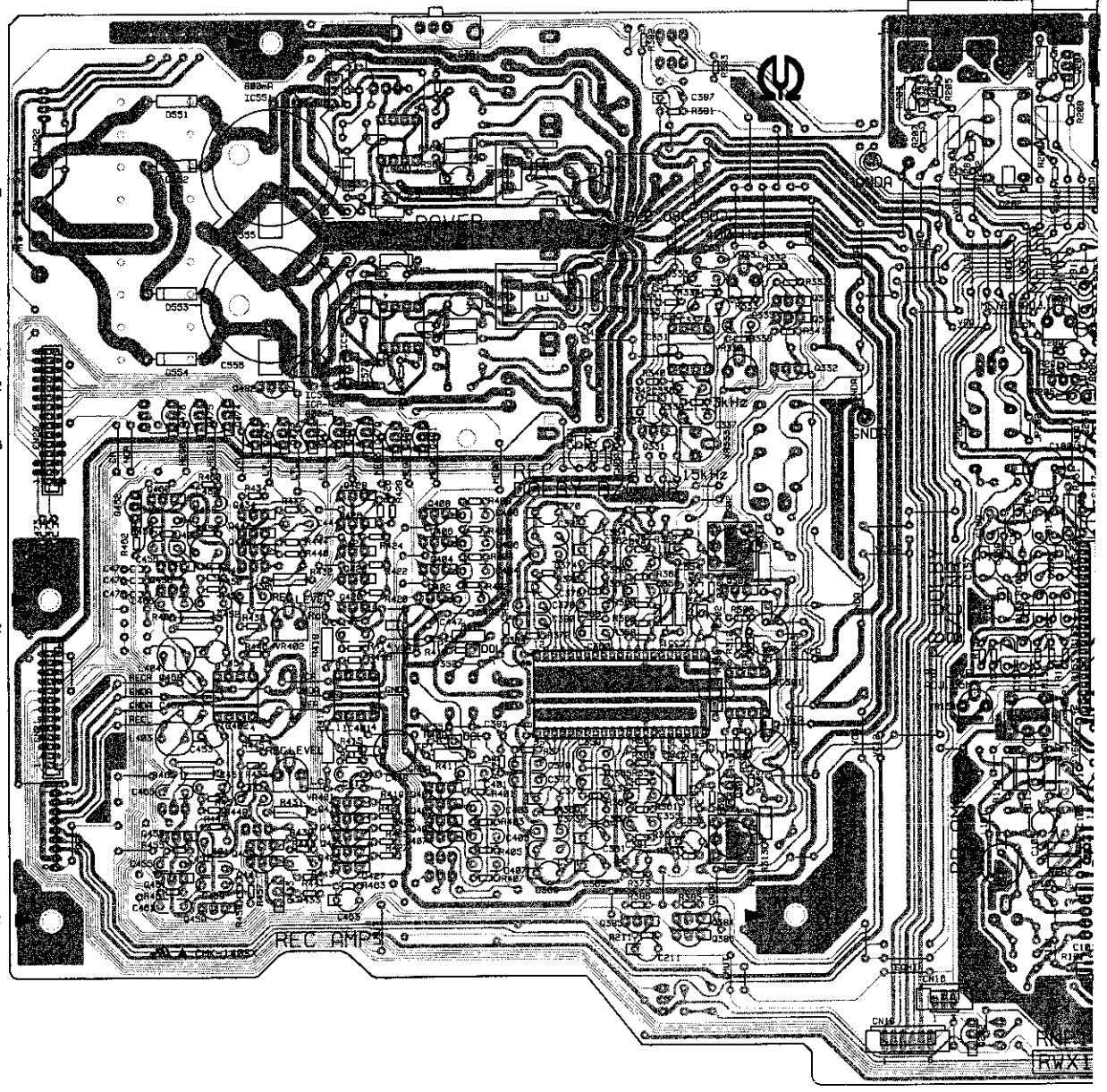

D

OPERATION UNIT

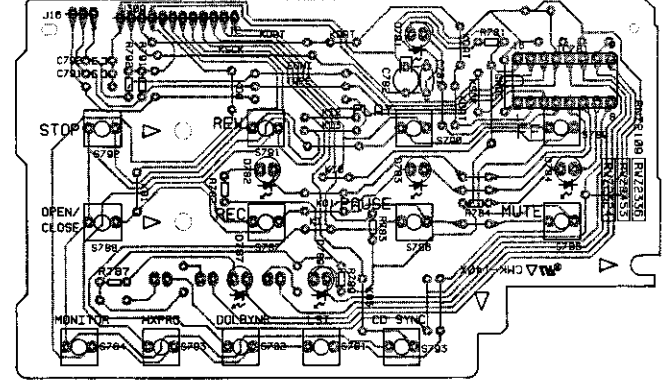

HEADPHONE UNIT

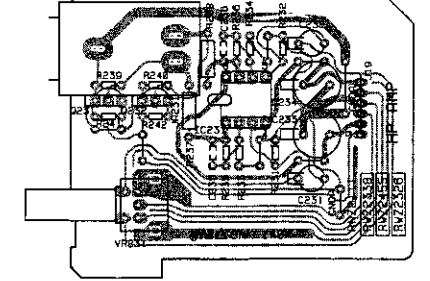

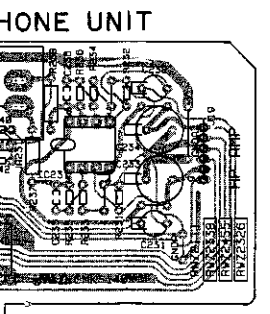
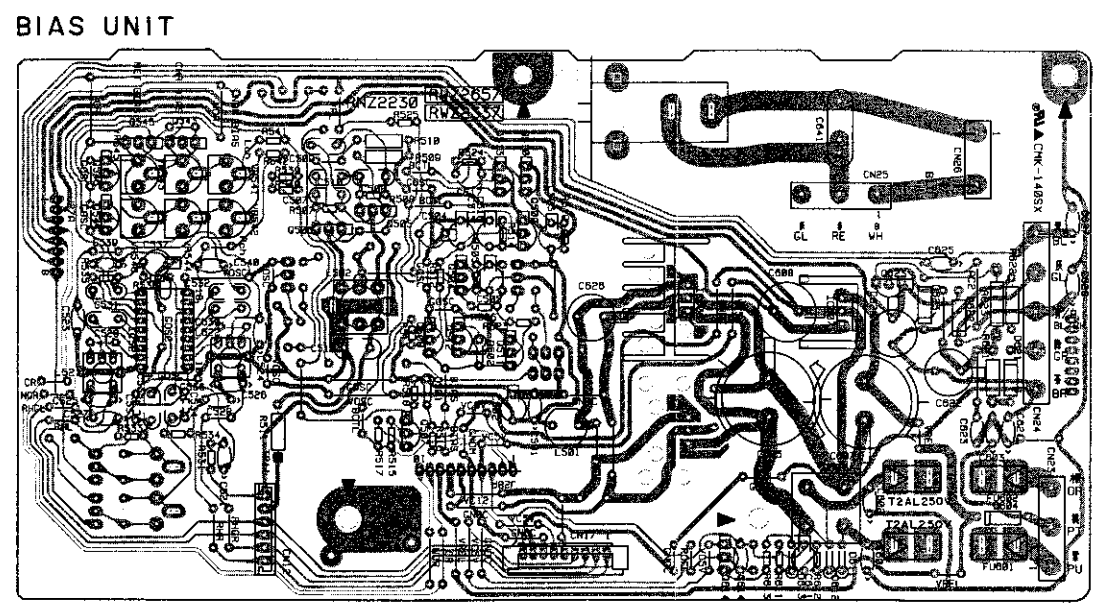
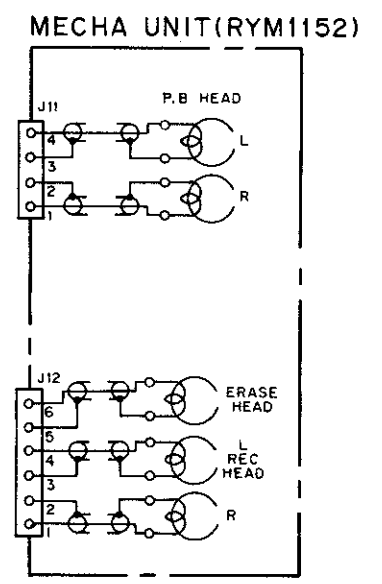
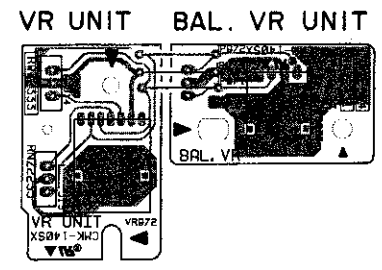
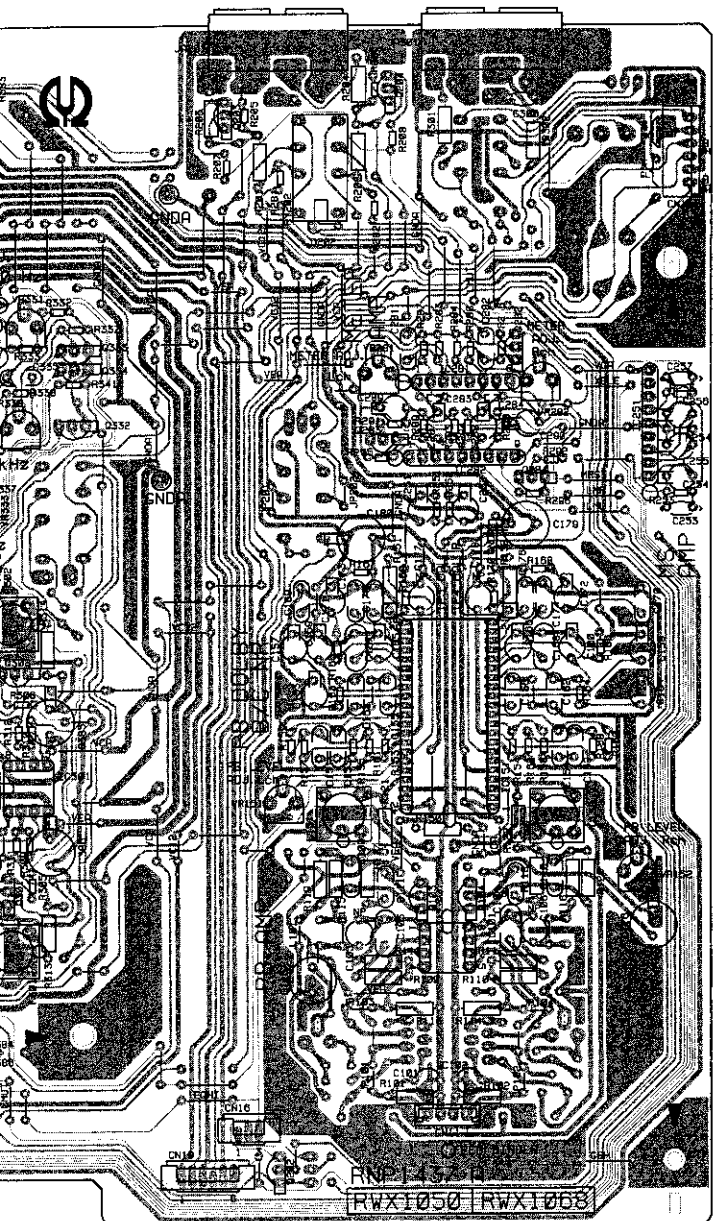

PCB. pattern diagram indication	Corresponding part symbol	Part name
		Transistor
		FET
		Diode
		Zener diode
		LED
		Varactor
		Tact switch
		Inductor
		Coil
		Transformer
		Filter
		Ceramic capacitor
		Mylar capacitor
		Styrol capacitor
		Electrolytic capacitor (Non polarized)
		Electrolytic capacitor (Noiseless)
		Electrolytic capacitor (Polarized)
		Electrolytic capacitor (Polarized)
		Power capacitor
		Semi-fixed resistor
		Resistor array
		Resistor
		Resonator
		Thermistor

1. This PCB connection diagram is viewed from the parts mounted side.
2. The parts which have been mounted on the board can be replaced with those shown with the corresponding wiring symbols listed in the above table.
3. The capacitor terminal marked with shows negative terminal.
4. The diode marked with shows cathode side.
5. The transistor terminal marked with shows emitter.

A

B

C

D

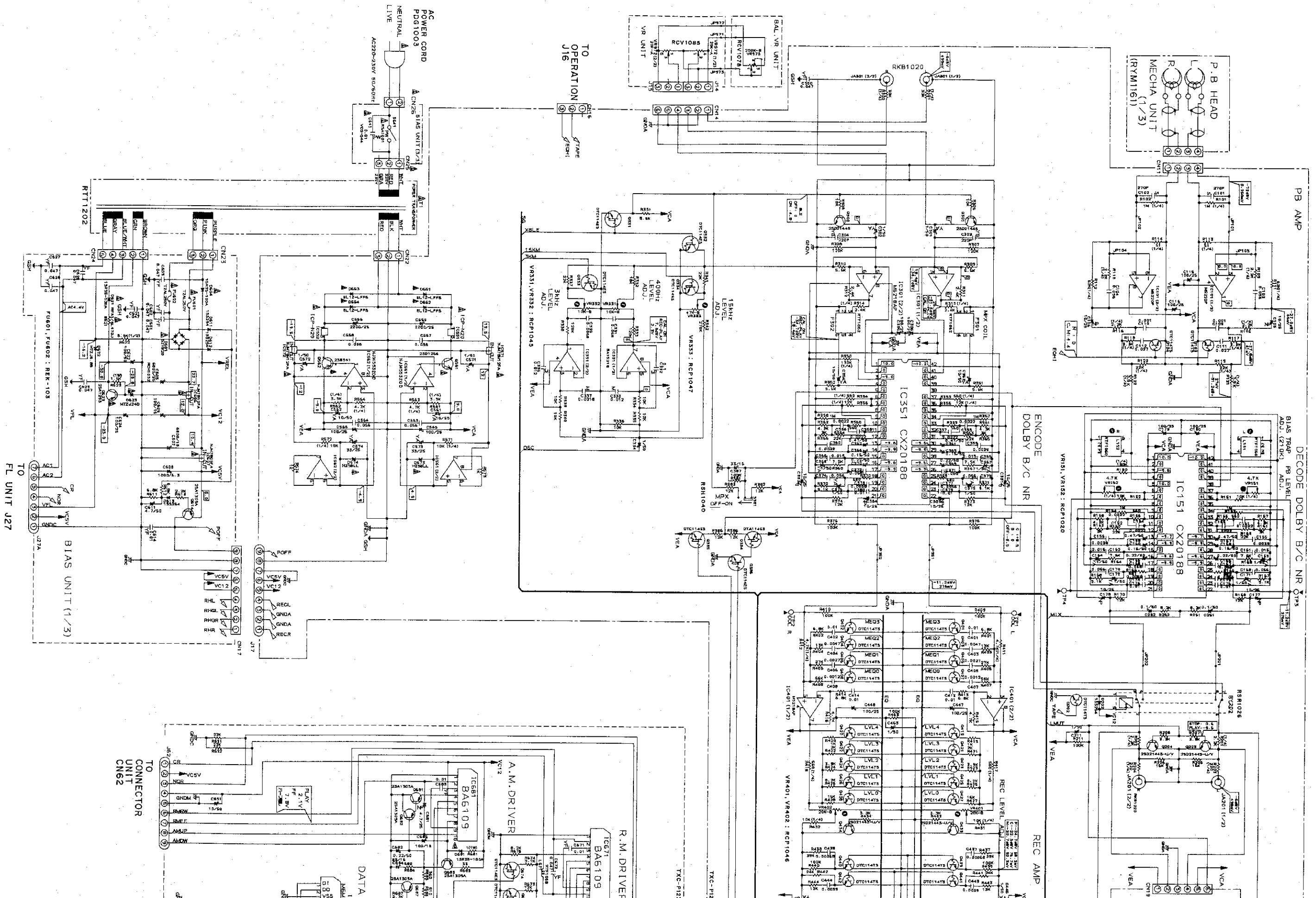

F

E

D

C

B

1

2

3

4

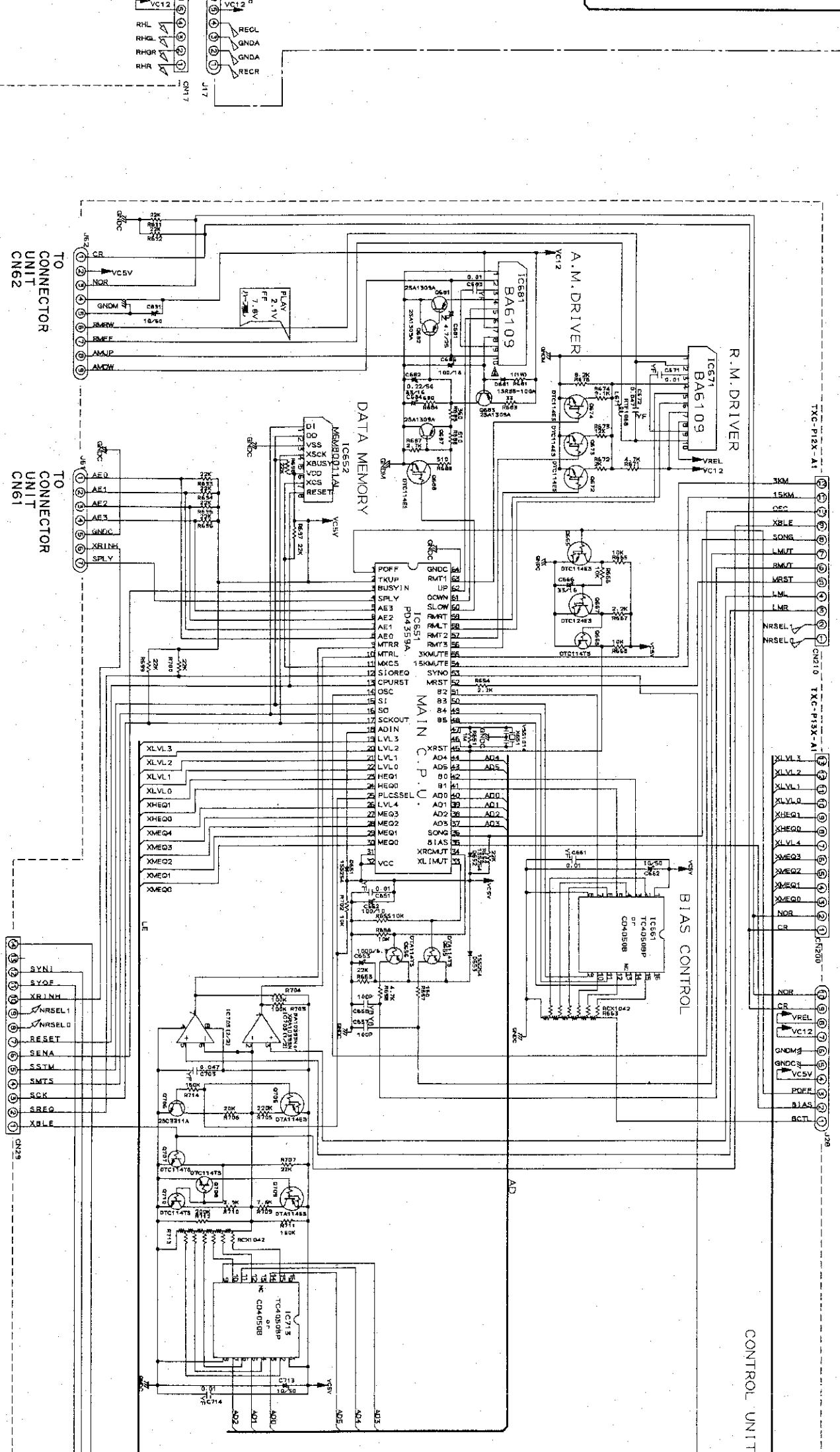
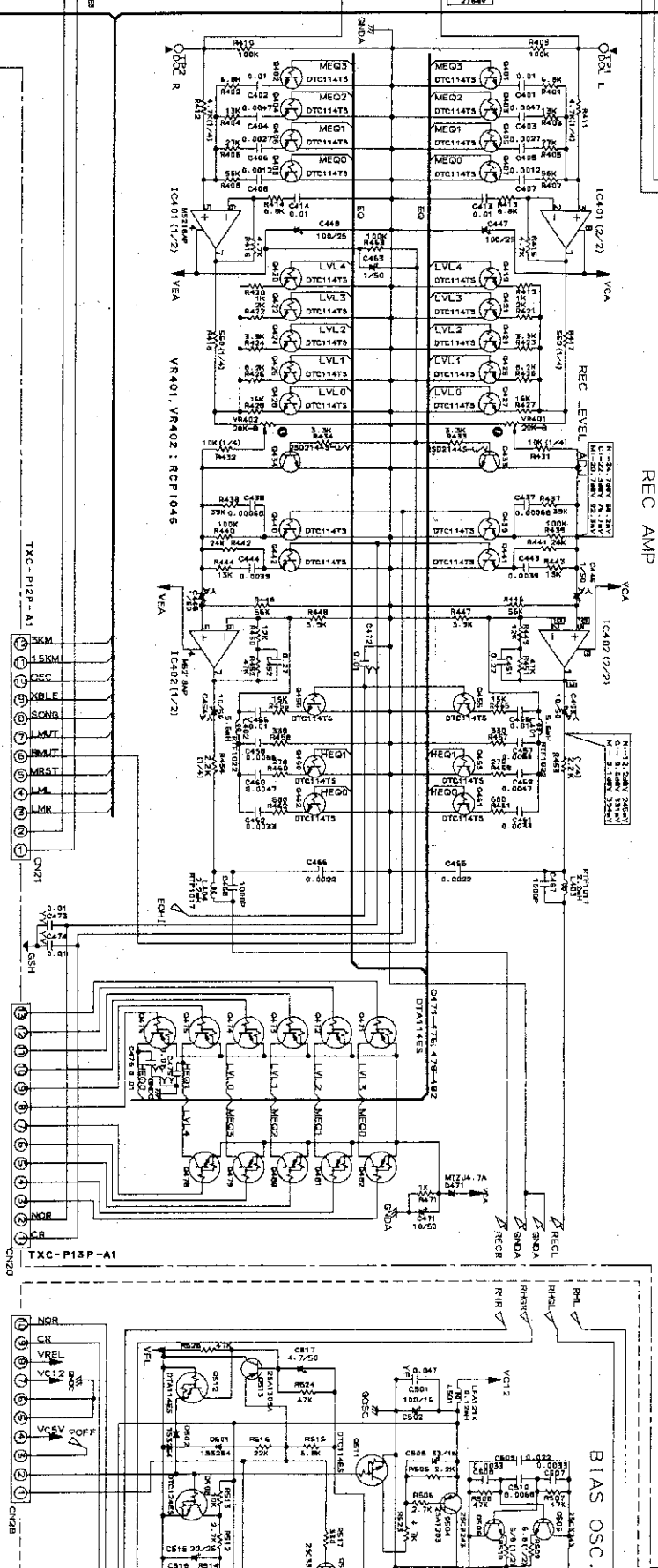
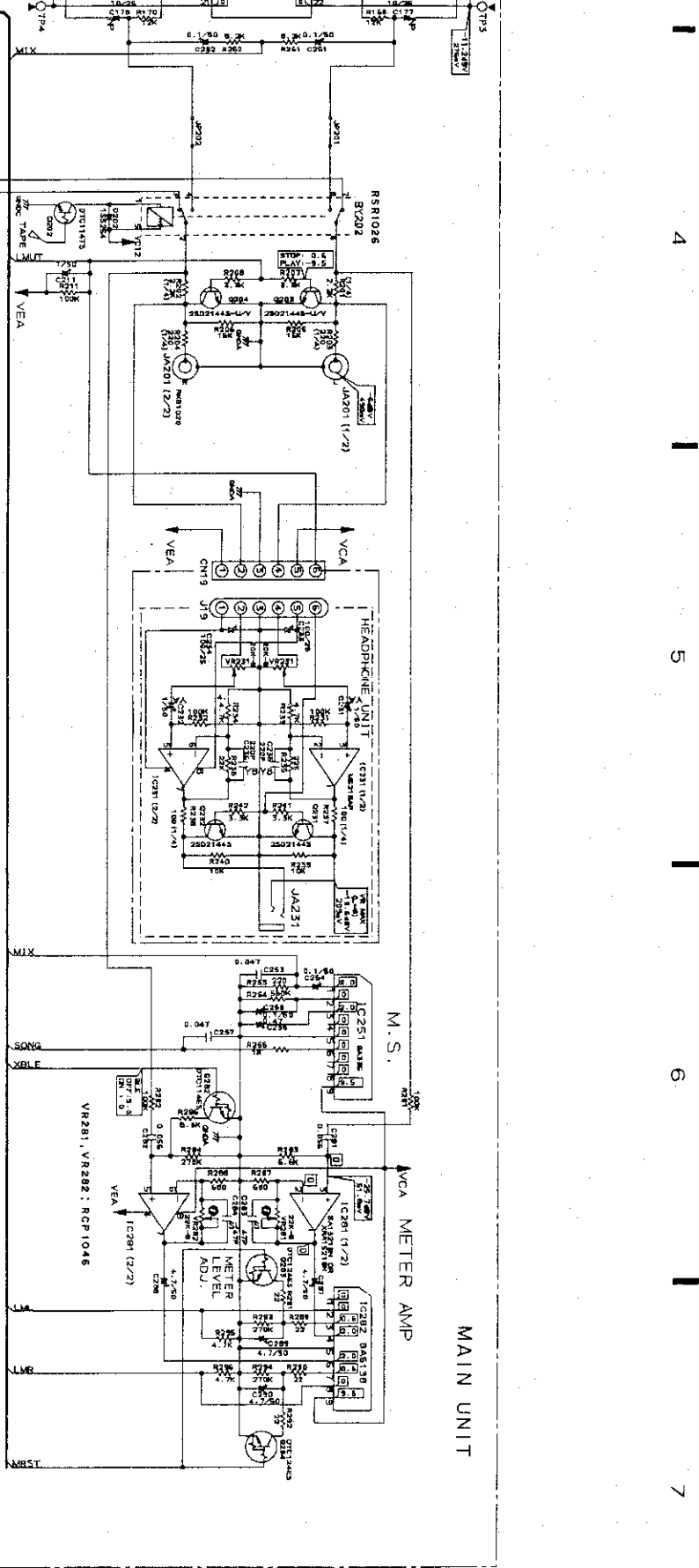

- RESISTORS:
Indicated in Ω , 1/4W, 1/8W, 1/BW, \pm otherwise rated K, R, M, Q, M, Q, (F) $\pm 1\%$, (M) $\pm 20\%$ tolerance.
- CAPACITORS:
Indicated in capacity (uF) / voltage (V) or pF. Indication without voltage is 50V capacitor.
- VOLTAGE CURRENT:
: DC voltage (V) at no input signal.
: AC current at no input signal.
- OTHERS:
: Signal route.
: Adjusting point.
The Δ mark found on some component importance of the safety factor of the replacing, be sure to use parts of identical value.
* marked capacitors and resistors have no vary due to improvements in design.



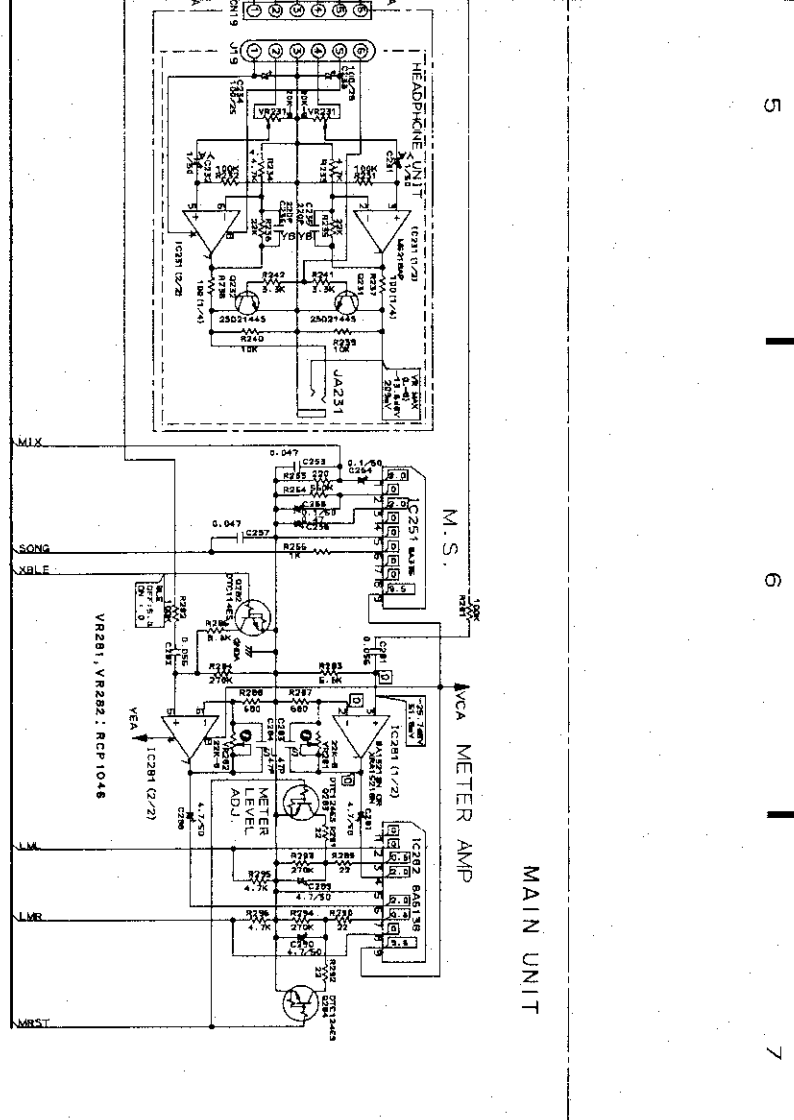

1. RESISTORS:
Indicated in Ω, 1/4W, 1/8W, 1/5W, ±5% tolerance unless otherwise noted; k:1kΩ, M:MΩ, (F): ±1%, (G): ±2%, (K): ±10%, (M): ±20% tolerance.
 2. CAPACITORS:
Indicated in capacity (μ F) / voltage (V) unless otherwise noted; p: pF; indication without voltage is 50V except electrolytic capacitor.
 3. VOLTAGE CURRENT:
V: DC voltage (V) at no input signal.
mA: DC current at no input signal.
 4. OTHERS:
: Signal trace.
Δ: Adjusting point.
The Δ mark found on some component parts indicates the importance of the safety factor of the part. Therefore, when replacing, be sure to use parts of identical designation.
* marked capacitors and resistors have parts numbers.
- This is the basic schematic diagram, but the actual circuit may vary due to improvements in design.

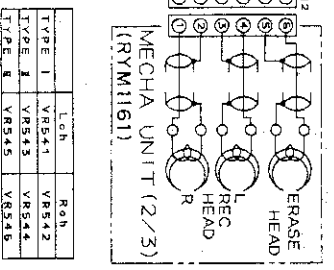
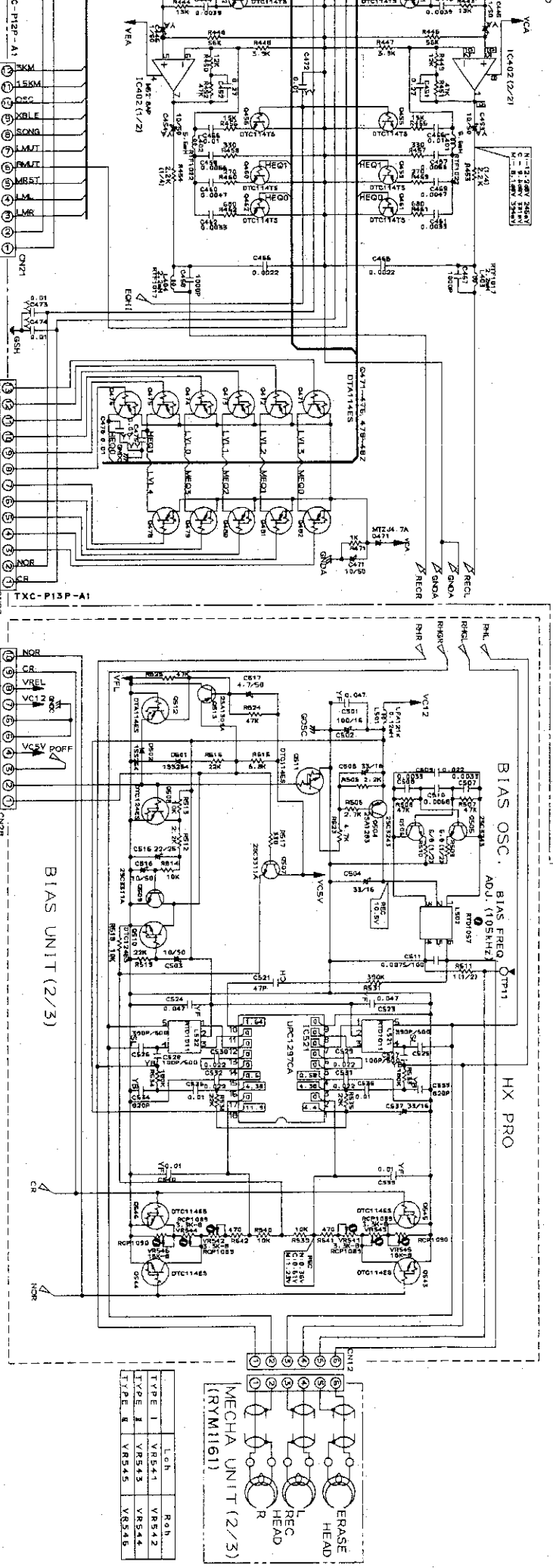

TYPE I	VR441	VR442
TYPE J	VR443	VR444
TYPE K	VR445	VR446

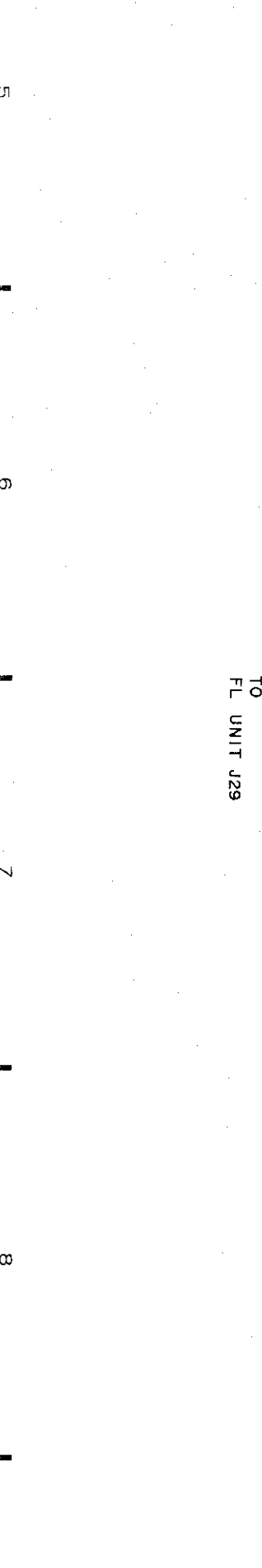
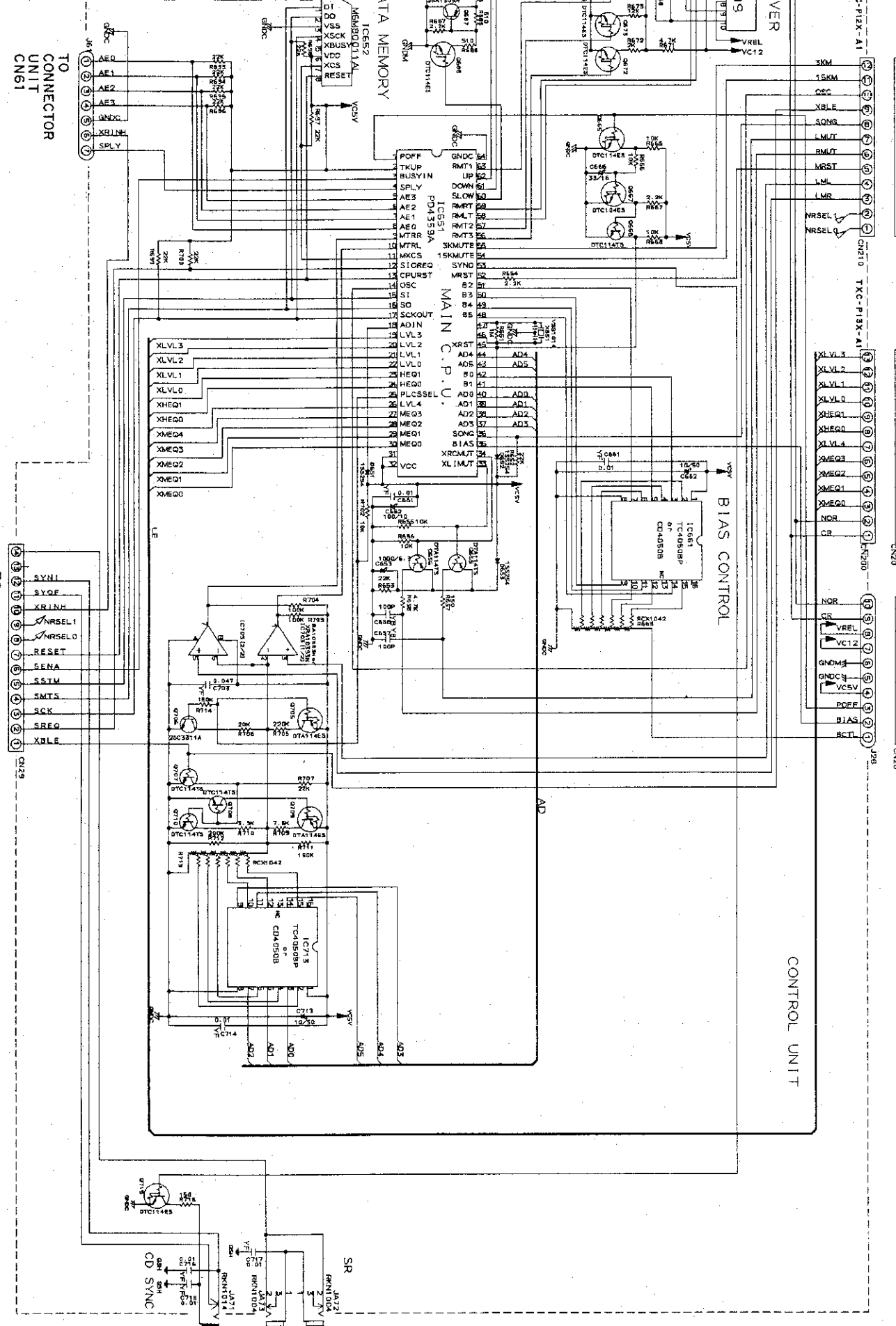

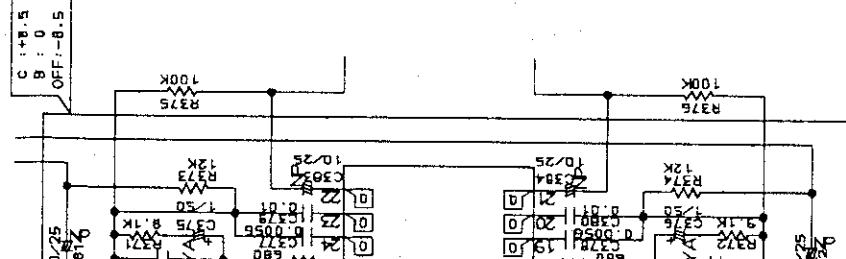

CT-S710, CT-S710-G

TO CONTROL UNIT CN29

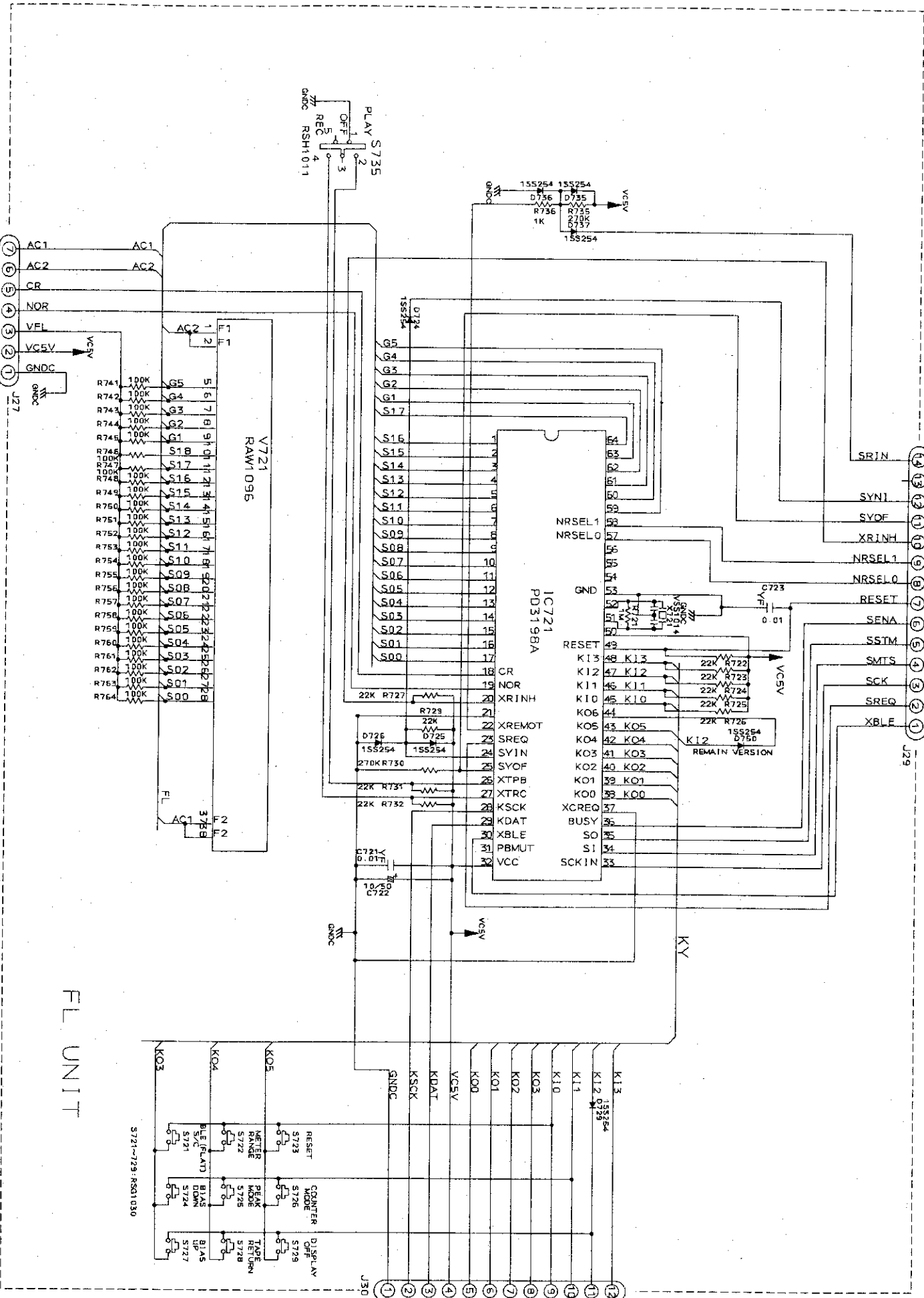

FL UNIT

TO BIAS UNIT CN27

TO BIAS UNIT CN27

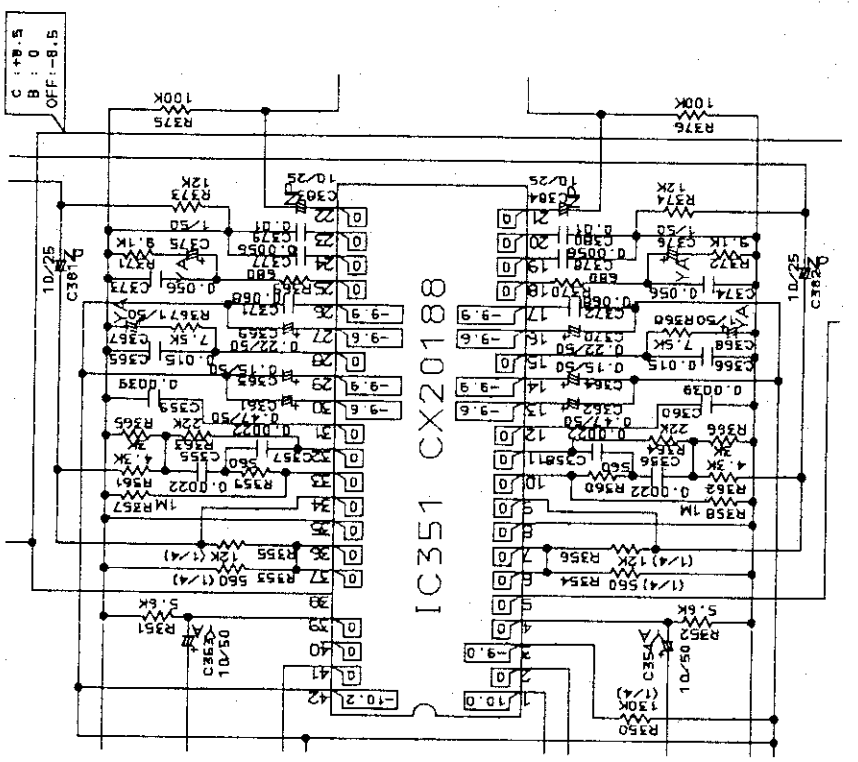

IC351 ENCODE DOLBY B/C/B NR

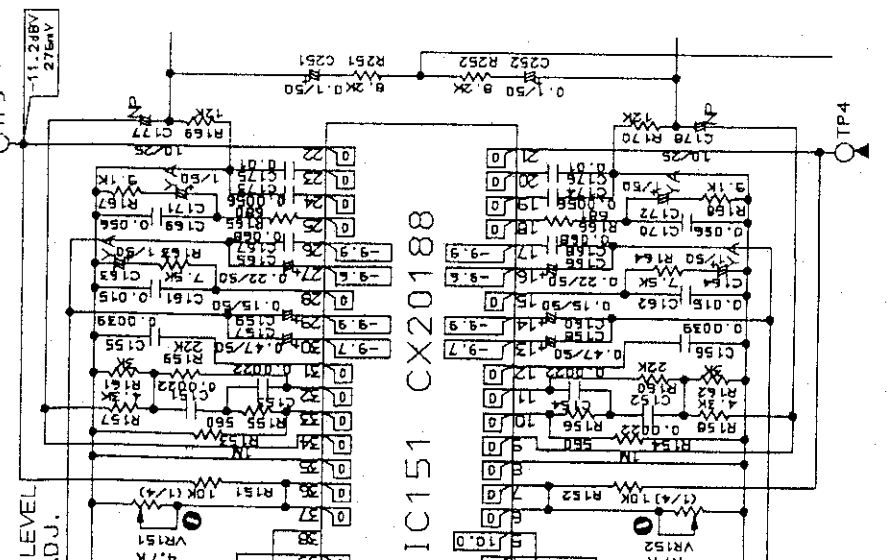

NR C/B AS

● PCB PARTS LIST

NOTES:

- Parts without part number cannot be supplied.
- Parts marked by "⊙" are not always kept in stock. Their delivery time may vary.
- The Δ mark found on some component parts indicates the importance of their use parts of identical designation.

- Ex.1 When there are 2 effective digits (any digit apart from 0), such as 560Ω → 56 × 10¹ → 561
 47kΩ → 47 × 10³ → 473
 0.5Ω → 0R5
 1Ω → 010
- Ex.2 When there are 3 effective digits (such as in high precision metal film 5.62kΩ → 562 × 10¹ → 5621

Mark No.	Description	Part No.	Ma
----------	-------------	----------	----

LIST OF ASSEMBLIES

Mark No.	Description	Part No.	Ma
	CONTROL UNIT		
	BALANCE VR UNIT		
	FL UNIT		
	FUNCTION UNIT		
	BIAS UNIT		
	HEADPHONE UNIT		
	MAIN UNIT		
	VR UNIT		

CONTROL UNIT

SEMICONDUCTORS

IC651 MAIN CPU	PD4359A
IC652	MGW80011AL
IC661 CMOS LOGIC IC	TC4050BP
IC671 IC	BA6109
IC681 IC	BA6109

IC703 COMPARATOR	BA10939N
IC713 CMOS LOGIC IC	TC4050BP
Q655, 656 DIGITAL TRANSISTOR	DTA114TS
Q665 TRANSISTOR	DTC114ES
Q667 TRANSISTOR	DTC124ES

Q668 DIGITAL TRANSISTOR	DTC114TS
Q672-674 TRANSISTOR	DTC114ES
Q681-683 TRANSISTOR	2SA1309A
Q687 TRANSISTOR	2SA1309A
Q688 TRANSISTOR	DTC114ES

Q705 DIGITAL TRANSISTOR	DTA114ES
Q706 TRANSISTOR	2SC3911A
Q707, 708 DIGITAL TRANSISTOR	DTC114TS
Q709 DIGITAL TRANSISTOR	DTA114ES
Q710 DIGITAL TRANSISTOR	DTC114TS

Q715 TRANSISTOR	DTC114ES
D651-653 DIODE	1SS254
D681 RECTIFIER DIODE	1SR35-100A

COILS/TRANSFORMERS

L671	RTF1068
------	---------

OTH

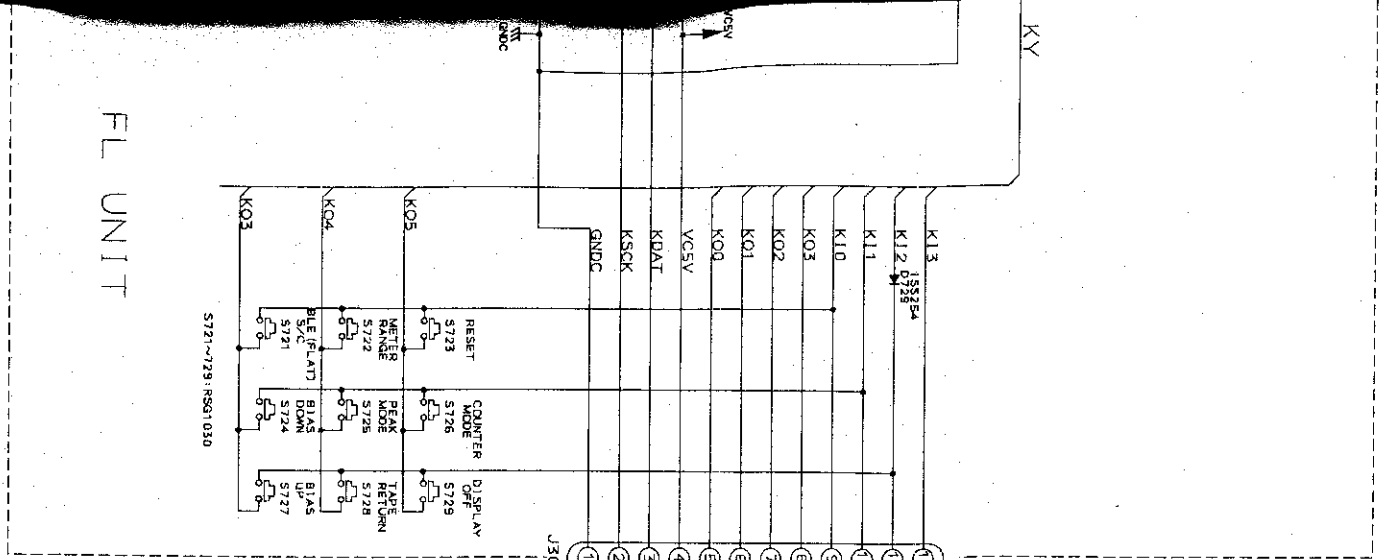

FL UNIT

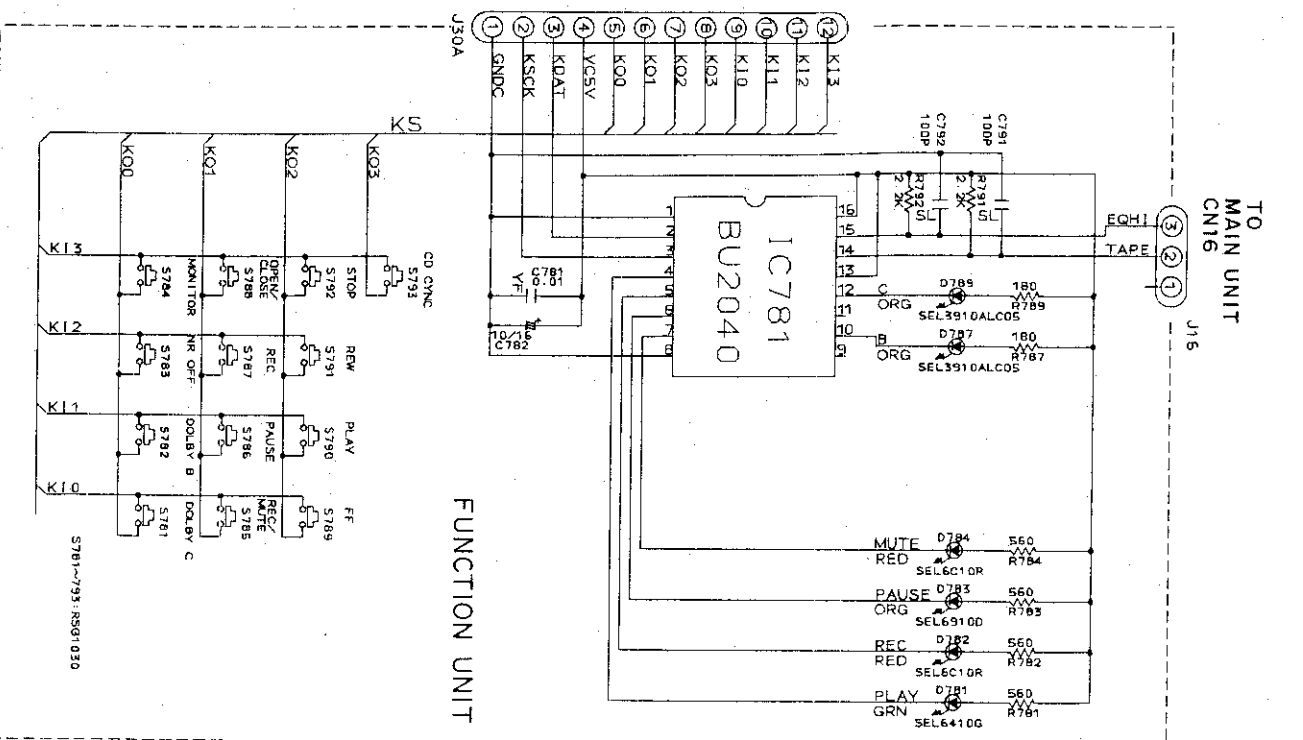

FUNCTION UNIT

TO MAIN UNIT

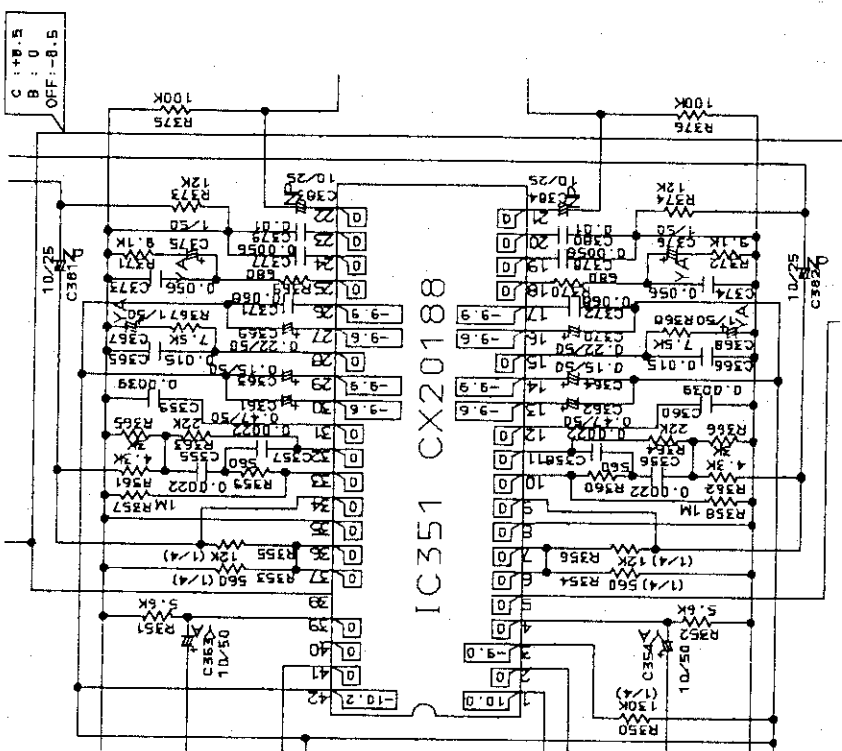

UN ENCODE DOLBY B/C UN 153C1

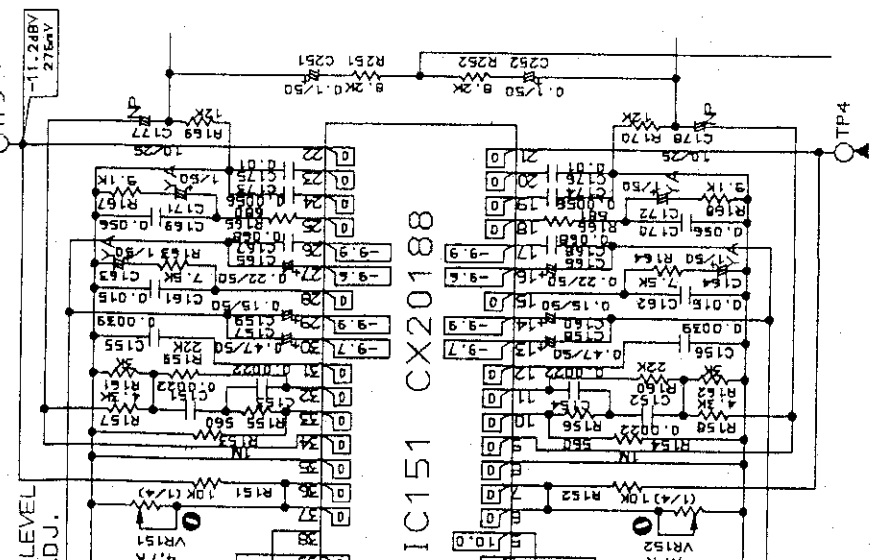

UN B/C UN 151C1

● PCB PARTS LIST

NOTES:

- Parts without part number cannot be supplied.
- Parts marked by "⊙" are not always kept in stock. Their delivery time may vary.
- The Δ mark found on some component parts indicates the importance of their correct location.
- When ordering resistors, first convert resistance values into code form as shown in the following examples.

Ex.1 When there are 2 effective digits (any digit apart from 0), such as 560
 $560 \Omega \rightarrow 56 \times 10^1 \rightarrow 561$
 $47k \Omega \rightarrow 47 \times 10^3 \rightarrow 473$
 $0.5 \Omega \rightarrow 0R5$
 $1 \Omega \rightarrow 010$
 Ex.2 When there are 3 effective digits (such as in high precision metal film)
 $5.62k \Omega \rightarrow 562 \times 10^1 \rightarrow 5621$

LIST OF ASSEMBLIES

Mark No.	Description	Part No.	Material
	CONTROL UNIT		
	BALANCE VR UNIT		
	FL UNIT		
	FUNCTION UNIT		
	BIAS UNIT		
	HEADPHONE UNIT		
	MAIN UNIT		
	VR UNIT		

CONTROL UNIT

SEMICONDUCTORS

IC651 MAIN CPU	PD4359A
IC652	M6M80011AL
IC661 CMOS LOGIC IC	TC4050BP
IC671 IC	BA6109
IC681 IC	BA6109

IC703 COMPARTOR	BA10393N
IC713 CMOS LOGIC IC	TC4050BP
Q655, 656 DIGITAL TRANSISTOR	DTA114FS
Q665 TRANSISTOR	DTC114ES
Q667 TRANSISTOR	DTC124ES

Q668 DIGITAL TRANSISTOR	DTC114FS
Q672-674 TRANSISTOR	DTC114ES
Q681-683 TRANSISTOR	2SA1309A
Q687 TRANSISTOR	2SA1309A
Q688 TRANSISTOR	DTC114ES

Q705 DIGITAL TRANSISTOR	DTA114FS
Q706 TRANSISTOR	2SC3311A
Q707, 708 DIGITAL TRANSISTOR	DTC114FS
Q709 DIGITAL TRANSISTOR	DTA114FS
Q710 DIGITAL TRANSISTOR	DTC114FS

Q715 TRANSISTOR	DTC114ES
D651-653 DIODE	1SS254
D681 RECTIFIER DIODE	1SR35-100A

COILS/TRANSFORMERS

RTF1068

1B

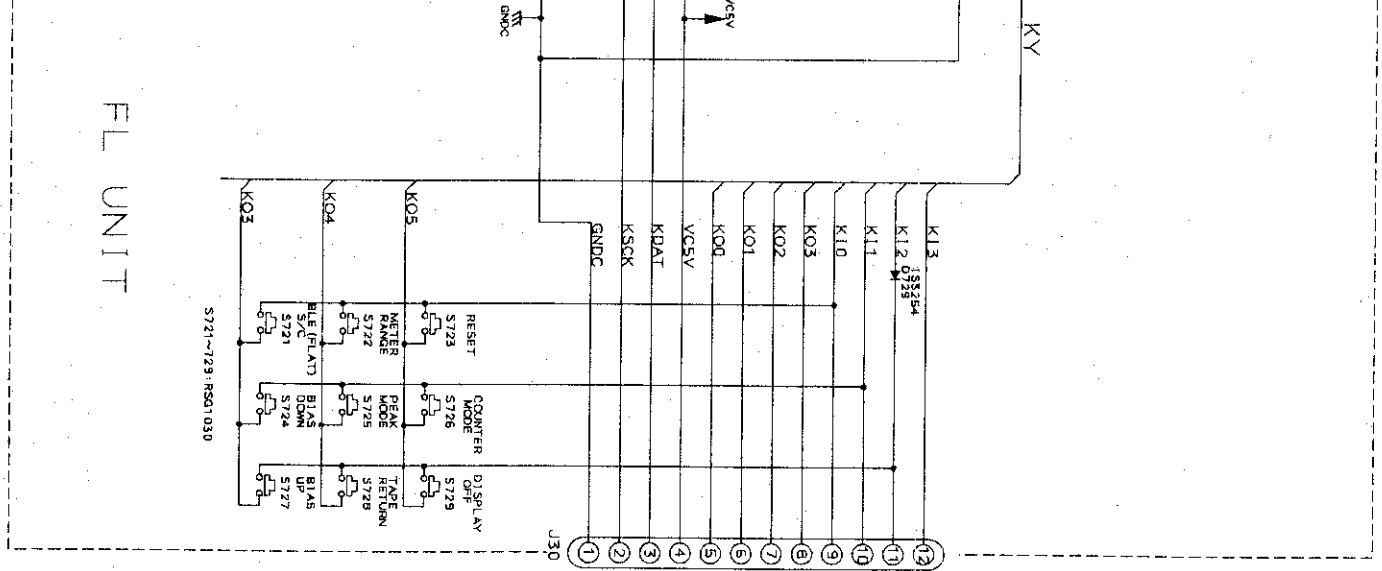

FL UNIT

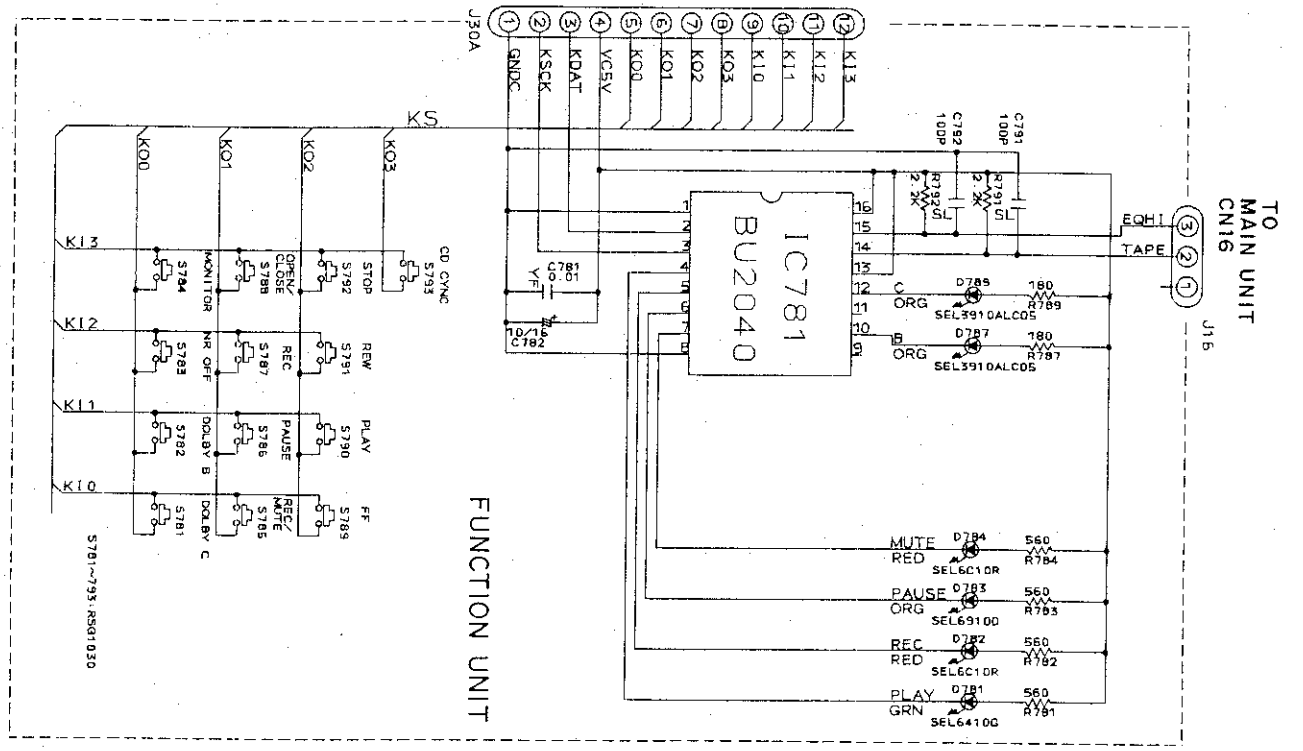

FUNCTION UNIT

TO MAIN UNIT CN16

4

5

6

1B

OTH

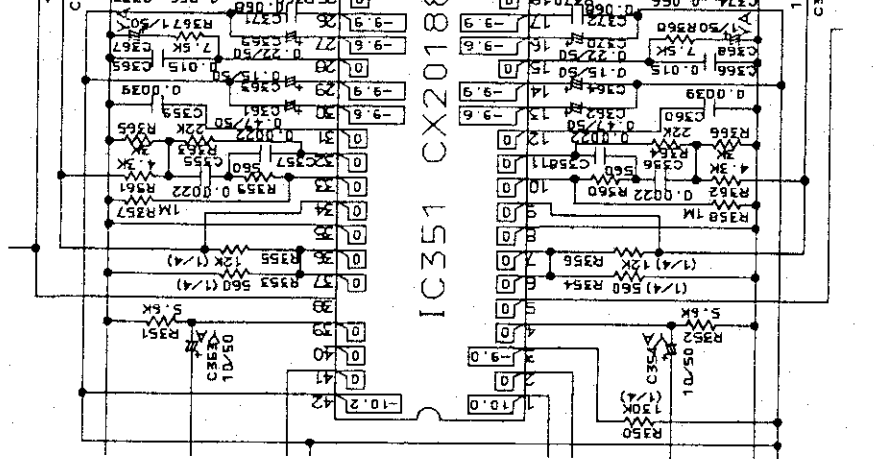

IC351 15C51 CX20188

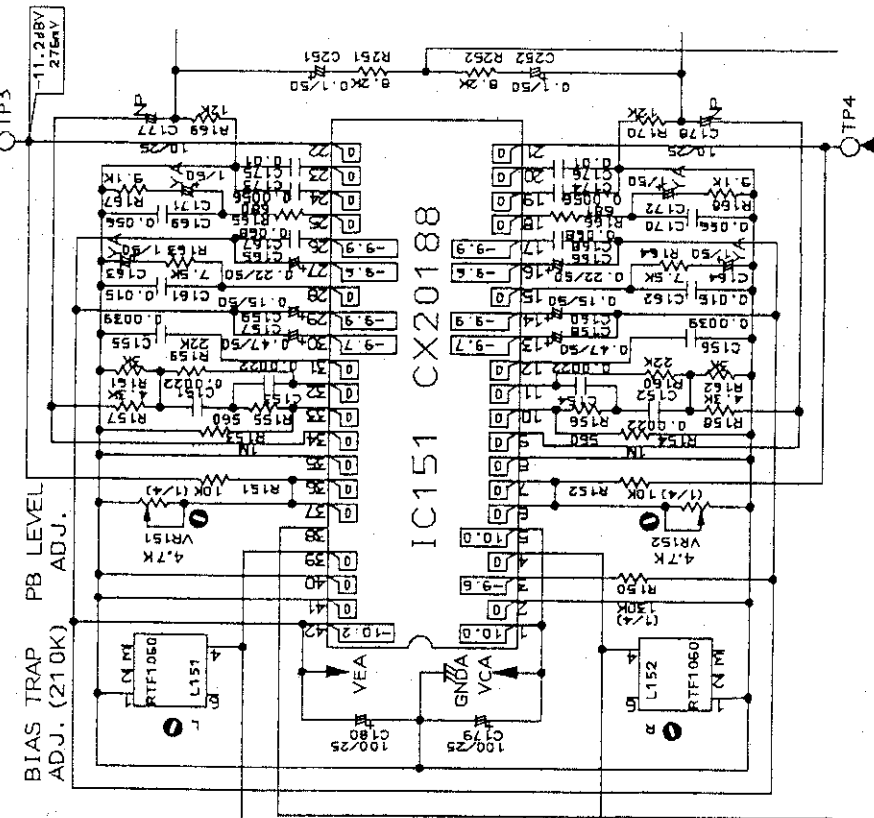

IC151 8151 CX20188

● PCB PARTS LIST

NOTES:

- Parts without part number cannot be supplied.
- Parts marked by "⊙" are not always kept in stock. Their delivery time may be longer than usual or they may be unavailable.
- The Δ mark found on some component parts indicates the importance of the safety factor of the part. Therefore, when replacing, be sure to use parts of identical designation.

- Ex.1 When there are 2 effective resistance values into code form as shown in the following examples:
 560 Ω → 56 × 10⁰ → 561 RD1/4PS 561J
 47k Ω → 47 × 10³ → 473 RD1/4PS 473J
 0.5 Ω → 0R5 RN2H0R5K
 1 Ω → 010 RS1P010K
- Ex.2 When there are 3 effective digits (such as in high precision metal film resistors):
 5.62k Ω → 562 × 10³ → 5621 RN1/4SR 5621F

LIST OF ASSEMBLIES

Mark No.	Description	Part No.	Mark No.	Description	Part No.
CONTROL UNIT					
CONTROL UNIT					
BALANCE VR UNIT					
FL UNIT					
FUNCTION UNIT					
BIAS UNIT					
HEADPHONE UNIT					
MAIN UNIT					
VR UNIT					
SEMICONDUCTORS					
IC651	MAIN CPU	PD4359A	IC652	M6M80011AL	CEAS100M50
IC652			IC661	OMOS LOGIC IC	CKCF103Z50
IC661	OMOS LOGIC IC	TC4050BP	IC671	IC	CEAS330M16
IC671	IC	BA6109	IC681	IC	CKCF103Z50
IC681	IC	BA6109			
CONTROL UNIT					
IC703					
IC713					
IC655					
IC665					
IC667					
RESISTORS					
Q668	DIGITAL TRANSISTOR	DTC114TS	Q672	674 TRANSISTOR	RD1/6PM
Q672	674 TRANSISTOR	DTC114ES	Q681	683 TRANSISTOR	RD1/6PM
Q681	683 TRANSISTOR	2SA1309A	Q687	TRANSISTOR	RS1LM
Q687	TRANSISTOR	2SA1309A	Q688	TRANSISTOR	
Q688	TRANSISTOR	DTC114ES			
RESISTORS					
Q705	DIGITAL TRANSISTOR	DTA114ES	Q706	TRANSISTOR	RD1/6PM
Q706	TRANSISTOR	2SC3111A	Q707	708 DIGITAL TRANSISTOR	RD1/6PM
Q707	708 DIGITAL TRANSISTOR	DTA114TS	Q709	DIGITAL TRANSISTOR	RD1/6PM
Q709	DIGITAL TRANSISTOR	DTA114ES	Q710	DIGITAL TRANSISTOR	RD1/6PM
Q710	DIGITAL TRANSISTOR	DTA114TS			

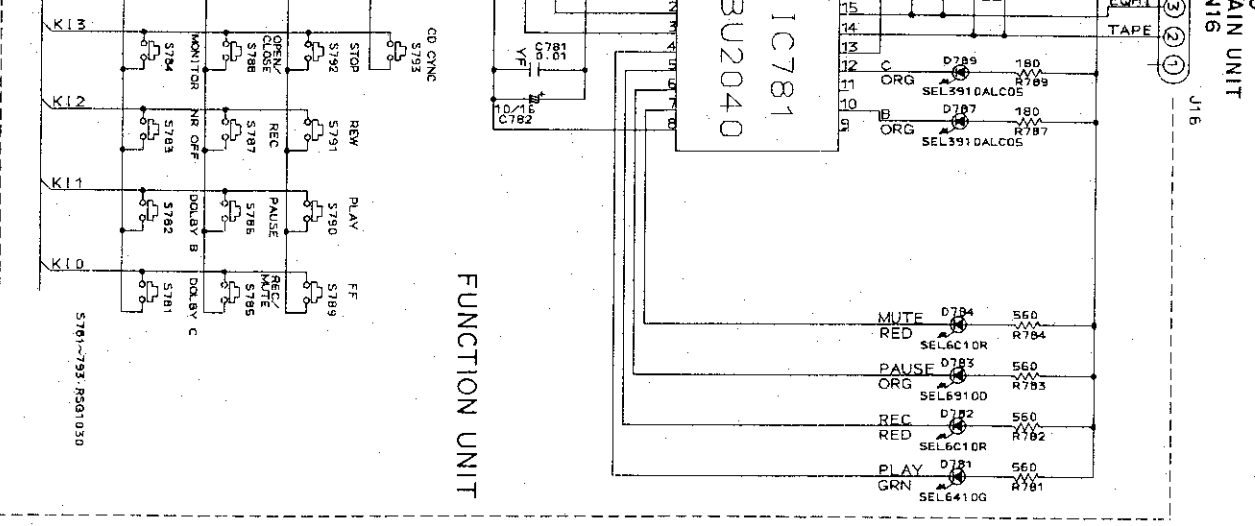

FUNCTION UNIT

5761-793-R0010310

COILS/TRANSFORMERS

- Q715 TRANSISTOR DTG114ES
- D651-653 DIODE ISS254
- D681 RECTIFIER DIODE ISR35-100A
- RTF1068

OTHERS

- CN200 CONNECTOR (13P)
- CN210 CONNECTOR (12P)
- J471 JACK
- TXC-P13X-A1
- TXC-P12X-A1
- RN1014

Mark	No.	Description	Part No.	Mark	No.	Description	Part No.
		JA72, 73 REMOTE CONTROL JACK	RKN1004			SWITCHES	
		X651 CERAMIC RESONATOR	VSS1014			S721-729 SWITCH	RSG1030
						S735	RSH1011
		BALANCE VR UNIT				CAPACITORS	
		RESISTORS				C721 CERAMIC CAPACITOR	CKCYF103Z50
		VR973 (200k)	RCV1078			C722 ELECTR. CAPACITOR	CEAS100M50
		FUNCTION UNIT				C723 CERAMIC CAPACITOR	CKCYF103Z50
		SEMICONDUCTORS				RESISTORS	
		IC781 LOGIC IC	BU2040			R721-727 CARBONFILM RESISTOR	RD1/6PM□□□J
		D781 LED	SEL6410G			R729-732 CARBONFILM RESISTOR	RD1/6PM□□□J
		D782	SEL6C10R			R735 CARBONFILM RESISTOR	RD1/6PM□□□J
		D783 LED	SEL6910D			R736 CARBONFILM RESISTOR	RD1/6PM□□□J
		D784	SEL6C10R			R741-764 CARBONFILM RESISTOR	RD1/6PM□□□J
		D787 LED	SEL3910ALC05			OTHERS	
		D789	SEL3910ALC05			V721	RAW1096
		SWITCHES				X721 CERAMIC RESONATOR	VSS1014
		S781-793 SWITCH	RSG1030			BIAS UNIT	
		CAPACITORS				SEMICONDUCTORS	
		C781 CERAMIC CAPACITOR	CKCYF103Z50			IC521 DOLBY HX PRO IC	UPC1297CA
		C782 ELECTR. CAPACITOR	CEJA100M16			△ IC606 REGULATOR IC	NJM7812FA
		C791, 792 AXIAL CAPACITOR	CKPUYB101K50			△ IC607 REGULATOR IC	NJM7805FA
		RESISTORS				Q504 TRANSISTOR	2SA1283
		R781-784 CARBONFILM RESISTOR	RD1/6PM□□□J			Q505, 506 TRANSISTOR	2SC3243
		R787 CARBONFILM RESISTOR	RD1/6PM□□□J			Q507 TRANSISTOR	2SC3311A
		R789 CARBONFILM RESISTOR	RD1/6PM□□□J			Q508 TRANSISTOR	DTC124ES
		R791, 792 CARBONFILM RESISTOR	RD1/6PM□□□J			Q509 TRANSISTOR	2SC3311A
		HEADPHONE UNIT				Q510 TRANSISTOR	DTC124ES
		SEMICONDUCTORS				Q511 TRANSISTOR	DTC114ES
		IC231 OP AMP	M5218AP			Q512 DIGITAL TRANSISTOR	DTA114ES
		Q231, 232 TRANSISTOR	2SD2144S			Q513 TRANSISTOR	2SA1309A
		CAPACITORS				Q543-546 TRANSISTOR	DTC114ES
		C231, 232 ELECTR. CAPACITOR	CEYA010M50			Q614 TRANSISTOR	2SA1309A
		C233, 234 ELECTR. CAPACITOR (100/25)	PCH1076			△ Q623 TRANSISTOR	2SA1283
		C235, 236 AXIAL CAPACITOR	CKPUYB221K50			D501, 502 DIODE	1SS254
		RESISTORS				D601	S2VB20
		R231-236 CARBONFILM RESISTOR	RD1/6PM□□□J			△ D604 RECRIFIER DIODE	1SR35-100A
		R237, 238 CARBONFILM RESISTOR	RD1/4PM□□□J			D611-613 DIODE	1SS254
		R239-242 CARBONFILM RESISTOR	RD1/6PM□□□J			△ D621 RECRIFIER DIODE	1SR35-100A
		VR231 VARIABLE RESISTOR (20k)	PCS1002			D622 ZENER DIODE	MTZJ6. 8B
		OTHERS				△ D623 ZENER DIODE	MTZJ24D
		JA231 JACK	RKN1002			SWITCHES	
		FL UNIT				△ S641 SWITCH	RSA1001
		SEMICONDUCTORS				COILS/TRANSFORMERS	
		IC721	PD3198A			L501	LFA121K
		D724-726 DIODE	1SS254			L502	RTD1057
		D729 DIODE	1SS254			L521, 522	RTD1011
		D735-737 DIODE	1SS254			CAPACITORS	
		D750 DIODE	1SS254			C501 CERAMIC CAPACITOR	CKCYF473Z50
						C502 ELECTR. CAPACITOR	CEAS101M16
						C503 ELECTR. CAPACITOR	CEAS100M50
						C504, 505 ELECTR. CAPACITOR	CEAS930M16
						C507, 508 AUDIO FILM CAPACITOR	CFTXA332J50

CT-S710, CT-S710-G

Mark	No.	Description	Part No.
	C509	AUDIO FILM CAPACITOR	CFTXA223J50
	C510	AUDIO FILM CAPACITOR	CFTXA682J50
	C511	PORYPROPYLENE FILM C	CQPA752J100
	C515	ELECTR. CAPACITOR	CEAS220M25
	C516	ELECTR. CAPACITOR	CEAS100M50
	C517	ELECTR. CAPACITOR	CEAS4R7M50
	C521	CERAMIC CAPACITOR	CCCCH470J50
	C523, 524	CERAMIC CAPACITOR	CKCYF473Z50
	C525, 526	CERAMIC CAPACITOR (390P/500)	RCG1004
	C527, 528	CERAMIC CAPACITOR	CCCSL101K500
	C529-532	AUDIO FILM CAPACITOR	CFTXA223J50
	C533, 534	AXIAL CAPACITOR	CKPUYB821K50
	C535, 536	AUDIO FILM CAPACITOR	CFTXA103J50
	C537	ELECTR. CAPACITOR	CEAS330M16
	C539, 540	CERAMIC CAPACITOR	CKCYF103Z50
	C601-603	CERAMIC CAPACITOR	CKCYF473Z50
	C605	ELECTR. CAPACITOR (6800 μ F/25)	RCH1032
	C607	ELECTR. CAPACITOR	CEAS682M16
	C608	ELECTR. CAPACITOR	CEAS102M6R3
	C611	ELECTR. CAPACITOR	CEAS4R7M50
	C614	CERAMIC CAPACITOR	CKCYF103Z50
	C621	CERAMIC CAPACITOR	CKCYF473Z50
	C622	ELECTR. CAPACITOR	CEAS101M50
	C623	CERAMIC CAPACITOR	CKCYF473Z50
	C624	ELECTR. CAPACITOR	CEAS101M25
	C625	CERAMIC CAPACITOR	CKCYF473Z50
	C626	ELECTR. CAPACITOR	CEAS101M16
	C627, 628	CERAMIC CAPACITOR	CKCYF473Z50
△	C641	CAPACITOR (0.01/AC400)	VCG-044
RESISTORS			
	R505-508	CARBONFILM RESISTOR	RD1/6PM□□□J
	R509, 510	CARBONFILM RESISTOR	RD1/2PMF□□□J
	R511	CARBONFILM RESISTOR	RD1/2LF□□□J
	R512-514	CARBONFILM RESISTOR	RD1/6PM□□□J
	R515, 516	METALFILM RESISTOR	RN1/6PQ□□□□F
	R517-519	CARBONFILM RESISTOR	RD1/6PM□□□J
	R523-525	CARBONFILM RESISTOR	RD1/6PM□□□J
	R531	CARBONFILM RESISTOR	RD1/6PM□□□J
	R533-536	CARBONFILM RESISTOR	RD1/6PM□□□J
	R539-542	CARBONFILM RESISTOR	RD1/6PM□□□J
	R611-613	CARBONFILM RESISTOR	RD1/6PM□□□J
△	R621	FUSIBLE RESISTOR	RFA1/4L□□□J
	R622	CARBONFILM RESISTOR	RD1/2PMF□□□J
	R623	METAL OXIDE RESISTOR	RS1LMF□□□J
	VR545, 546	VR(15k)	RCP1090
	VR541-544	(3. 3k)	RCP1089
MAIN UNIT			
SEMICONDUCTORS			
	IC101	OP-AMP-IC	M5220P
	IC151	DOLBY-B, C IC	CX20188
	IC251	IC	BA335
	IC281	IC	BA15218N
	IC282	IC	BA6138

Mark	No.	Description	Part No.
	IC301	OP-AMP, IC	M5218AP
	IC331	OP-AMP IC	BA15218
	IC351	DOLBY-B, C IC	CX20188
	IC401, 402	OP AMP	M5218AP
△	IC551, 552	IC PROTECTOR	ICP-N20
	IC561, 562	OP-AMP IC	NJM5532DD
△	IC571	REGULATOR IC	NJM78M12FA
△	IC572	REGULATOR IC	NJM79M12FA
	Q104	DIGITAL TRANSISTOR	DTC114TS
	Q202	DIGITAL TRANSISTOR	DTC114TS
	Q203, 204	TRANSISTOR	2SD2144S
	Q282	TRANSISTOR	DTC114ES
	Q283, 284	TRANSISTOR	DTC124ES
	Q301, 302	TRANSISTOR	2SD2144S
	Q303	DIGITAL TRANSISTOR	DTC114TS
	Q331-334	TRANSISTOR	DTC114ES
	Q384	DIGITAL TRANSISTOR	DTA114ES
	Q385, 386	TRANSISTOR	DTC114ES
	Q401-408	DIGITAL TRANSISTOR	DTC114TS
	Q419-428	DIGITAL TRANSISTOR	DTC114TS
	Q433, 434	TRANSISTOR	2SD2144S
	Q439-442	DIGITAL TRANSISTOR	DTC114TS
	Q455, 456	DIGITAL TRANSISTOR	DTC114TS
	Q459-462	DIGITAL TRANSISTOR	DTC114TS
	Q471-476	DIGITAL TRANSISTOR	DTA114ES
	Q478-482	DIGITAL TRANSISTOR	DTA114ES
△	Q561	TRANSISTOR	2SD1266
△	Q562	TRANSISTOR	2SB941
△	D551-554		ELIZ-LFF5
△	D573, 574	ZENER DIODE	HZ5BLL
SWITCHES			
	S381		RSH1040
RELAYS			
	RY202		RSR1026
COILS/TRANSFORMERS			
	L151, 152	BIAS TRAP(210KHZ)	RTF1060
	L401, 402	COIL	RTF1022
	L403, 404		RTF1017
	F301, 302	FILTER	RTF1062
CAPACITORS			
	C101, 102	PL. STYRENE CAPACITOR	CQSF271J50
	C103, 104	AUDIO FILM CAPACITOR	CFTXA563J50
	C105, 106	ELECTR. CAPACITOR (10/25)	RCH1037
	C109, 110	AUDIO FILM CAPACITOR	CFTXA102J50
	C111, 112	AUDIO FILM CAPACITOR	CFTXA273J50
	C115, 116	ELECTR. CAPACITOR (100/25)	PCH1076
	C151-154	AUDIO FILM CAPACITOR	CFTXA222J50
	C155, 156	AUDIO FILM CAPACITOR	CFTXA392J50
	C157, 158	AUDIO FILM CAPACITOR	CEASR47M50
	C159, 160	AUDIO FILM CAPACITOR	CEASR15M50
	C161, 162	AUDIO FILM CAPACITOR	CFTXA153J50
	C163, 164	ELECTR. CAPACITOR	CEASO10M50
	C165, 166	AUDIO FILM CAPACITOR	CEASR22M50
	C167, 168	AUDIO FILM CAPACITOR	CFTXA683J50

Mark No.	Description	Part No.
C169, 170	AUDIO FILM CAPACITOR	CFTXA563J50
C171, 172	ELECTR. CAPACITOR	CEAS010M50
C173, 174		CFTXA562J50
C175, 176	AUDIO FILM CAPACITOR	CFTXA103J50
C177, 178	ELECTR. CAPACITOR (10/25)	RCH1037
C179, 180	ELECTR. CAPACITOR (100/25)	PCH1076
C211	ELECTR. CAPACITOR	CEAS010M50
C251, 252	ELECTR. CAPACITOR	CEASR10M50
C253	AUDIO FILM CAPACITOR	CFTXA473J50
C254, 255	ELECTR. CAPACITOR	CEASR10M50
C256	ELECTR. CAPACITOR	CEASR47M50
C257	AUDIO FILM CAPACITOR	CFTXA473J50
C281, 282	AUDIO FILM CAPACITOR	CFTXA563J50
C283, 284	AXIAL CERAMIC C.	CCPUSL470J50
C287-290	ELECTR. CAPACITOR	CEAS4R7M50
C300	CERAMIC CAPACITOR	CKCYF473Z50
C301, 302	ELECTR. CAPACITOR	CEYA010M50
C303, 304	AXIAL CAPACITOR	CKPUYB221K50
C331	AUDIO FILM CAPACITOR	CFTXA683J50
C332	MYLAR FILM CAPACITOR	CQMA104J50
C333	MYLAR FILM CAPACITOR	CQMA123J50
C334	ELECTR. CAPACITOR	CEAS010M50
C335	AUDIO FILM CAPACITOR	CFTXA682J50
C336	MYLAR FILM CAPACITOR	CQMA123J50
C337	MYLAR FILM CAPACITOR	CQMA182J50
C353, 354	ELECTR. CAPACITOR	CEYA100M50
C355-358	AUDIO FILM CAPACITOR	CFTXA222J50
C359, 360	AUDIO FILM CAPACITOR	CFTXA392J50
C361, 362	AUDIO FILM CAPACITOR	CEASR47M50
C363, 364	AUDIO FILM CAPACITOR	CEASR15M50
C365, 366	AUDIO FILM CAPACITOR	CFTXA153J50
C367, 368	ELECTR. CAPACITOR	CEAS010M50
C369, 370	AUDIO FILM CAPACITOR	CEASR22M50
C371, 372	AUDIO FILM CAPACITOR	CFTXA683J50
C373, 374	AUDIO FILM CAPACITOR	CFTXA563J50
C375, 376	ELECTR. CAPACITOR	CEAS010M50
C377, 378		CFTXA562J50
C379, 380	AUDIO FILM CAPACITOR	CFTXA103J50
C381-384	ELECTR. CAPACITOR (10/25)	RCH1037
C385, 386	ELECTR. CAPACITOR (100/25)	PCH1076
C387	ELECTR. CAPACITOR	CEAS330M16
C401, 402	AUDIO FILM CAPACITOR	CFTXA103J50
C403, 404	AUDIO FILM CAPACITOR	CFTXA472J50
C405, 406		CFTXA272J50
C407, 408	AUDIO FILM CAPACITOR	CFTXA122J50
C413, 414	AUDIO FILM CAPACITOR	CFTXA103J50
C445, 446		CEYA010M50
C437, 438		CFTXA681J50
C443, 444	AUDIO FILM CAPACITOR	CFTXA392J50
C447, 448	ELECTR. CAPACITOR (100/25)	PCH1076
C451, 452	AUDIO FILM CAPACITOR	CFTXA274J50
C453, 454	ELECTR. CAPACITOR	CEYA100M50
C455, 456	AUDIO FILM CAPACITOR	CFTXA103J50
C457, 458		CFTXA562J50

Mark No.	Description	Part No.
C459, 460	AUDIO FILM CAPACITOR	CFTXA472J50
C461, 462	AUDIO FILM CAPACITOR	CFTXA332J50
C463	ELECTR. CAPACITOR	CEAS010M50
C467, 468	PL. STYRENE CAPACITOR	CQSA102J50
C471	ELECTR. CAPACITOR	CEAS100M50
C472-476	CERAMIC CAPACITOR	CKPUY103N16
C465, 466		CFTXA222J50
C551-554	CERAMIC CAPACITOR	CKCYF473Z50
C555, 556	ELECTR. CAPACITOR (200/25)	RCH1036
C557, 558	AUDIO FILM CAPACITOR	CFTXA563J50
C561, 562	ELECTR. CAPACITOR	CEYA100M50
C563, 564	AUDIO FILM CAPACITOR	CFTXA563J50
C565, 566	ELECTR. CAPACITOR (100/25)	PCH1076
C571, 572	ELECTR. CAPACITOR	CEYA010M50
C573, 574	ELECTR. CAPACITOR	CEYA330M25

RESISTORS

R101, 102	CARBONFILM RESISTOR	RD1/4PM□□□J
R109-122	CARBONFILM RESISTOR	RD1/4PM□□□J
R150-152	CARBONFILM RESISTOR	RD1/4PM□□□J
R153-170	CARBONFILM RESISTOR	RD1/6PM□□□J
R201-204	CARBONFILM RESISTOR	RD1/4PM□□□J
R205-208	CARBONFILM RESISTOR	RD1/6PM□□□J
R211	CARBONFILM RESISTOR	RD1/6PM□□□J
R251-255	CARBONFILM RESISTOR	RD1/6PM□□□J
R281-284	CARBONFILM RESISTOR	RD1/6PM□□□J
R286-296	CARBONFILM RESISTOR	RD1/6PM□□□J
R301, 302	CARBONFILM RESISTOR	RD1/4PM□□□J
R305-312	CARBONFILM RESISTOR	RD1/6PM□□□J
R313, 314	CARBONFILM RESISTOR	RD1/4PM□□□J
R331-342	CARBONFILM RESISTOR	RD1/6PM□□□J
R350	CARBONFILM RESISTOR	RD1/4PM□□□J
R351, 352	CARBONFILM RESISTOR	RD1/6PM□□□J
R353-356	CARBONFILM RESISTOR	RD1/4PM□□□J
R357-376	CARBONFILM RESISTOR	RD1/6PM□□□J
R381-383	CARBONFILM RESISTOR	RD1/6PM□□□J
R385, 386	CARBONFILM RESISTOR	RD1/6PM□□□J
R401-408	CARBONFILM RESISTOR	RD1/6PM□□□J
R409, 410 (100k)		RCN1043
R411, 412	CARBONFILM RESISTOR	RDR1/4PM□□□J
R413-416	CARBONFILM RESISTOR	RD1/6PM□□□J
R417, 418	CARBONFILM RESISTOR	RD1/4PM□□□J
R419-428	CARBONFILM RESISTOR	RD1/6PM□□□J
R431, 432	CARBONFILM RESISTOR	RD1/4PM□□□J
R433, 434	CARBONFILM RESISTOR	RD1/6PM□□□J
R437-452	CARBONFILM RESISTOR	RD1/6PM□□□J
R453, 454	CARBONFILM RESISTOR	RD1/4PM□□□J
R455-463	CARBONFILM RESISTOR	RD1/6PM□□□J
R471	CARBONFILM RESISTOR	RD1/6PM□□□J
R561-564	CARBONFILM RESISTOR	RD1/4PM□□□J
R571, 572	CARBONFILM RESISTOR	RD1/4PM□□□J
R573, 574	CARBONFILM RESISTOR	RD1/6PM□□□J
VR151, 152	VARIABLE RESISTOR (4.7k)	RCP1020
VR281, 282	VR (22k)	RCP1046

CT-S710, CT-S710-G

Mark	No.	Description	Part No.
	VR331, 332	VR (10k)	RCP1045
	VR333	VR (47k)	RCP1047
	VR401, 402	VARIABLE RESISTOR (20k)	RCP1046

OTHERS

SCREW	IBZ30P100FCC
CN20	TXC-P13P-A1
CN21	TXC-P12P-A1
JA201 JACK	RKB1020
JA301 JACK	RKB1020

VR UNIT RESISTORS

VR972	VR (20k)	RCV1085
-------	----------	---------

• ADJUSTMENT

RECORDING SECTION

Bias Oscillator Adjustment

No.	Mode	Input signal & test tape	Adjustment location		Measuring location	Adjustment value	Remarks
1.	REC/ PLAY	Load the STD-610 test tape with no input signal.	Deck	L502	TP. 11	108 kHz \pm 300 Hz	

• REGLAGE

SECTION D'ENREGISTREMENT

Réglage de l'oscillateur de polarisation

No.	Mode	Signal d'entrée et bande d'essai	Points de réglage		Points de mesure	Valeur de réglage	Remarques
1.	REC/ PLAY	Charger la bande d'essai STD-610 et n'introduire aucun signal.	Platine	L502	TP. 11	108 kHz \pm 300 Hz	

• AJUSTE

SECCIÓN DE GRABACIÓN

Ajuste del oscilador de polarización

N.º	Modo	Señal de entrada y cinta de prueba	Punto de ajuste		Punto de medición	Valor de ajuste	Comentarios
1.	REC/ PLAY	Introduzca la cinta de prueba STD-610 sin señal de entrada.	Platina	L502	TP. 11	108 kHz \pm 300 Hz	

Service Manual

 **PIONEER®**
The Art of Entertainment

3754

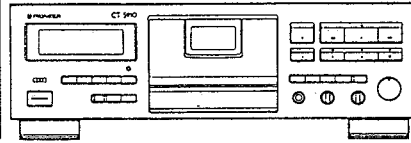

ORDER NO.
ARP2482

STEREO CASSETTE DECK

CT-S910

- This manual is applicable to HEM type.
- Ce manuel pour le service comprend les explications de réglage en français.
- Este manual de servicio trata del método ajuste escrito en español.

CONTENTS

1. EXPLODED VIEWS AND PARTS LIST	2
2. PACKING	8
3. BLOCK DIAGRAM	9
4. SCHEMATIC AND PCB CONNECTIONS DIAGRAMS	10
5. PCB PARTS LIST	23
6. ADJUSTMENTS	28
6. REGLAGES	33
6. AJUSTES	38
7. SPECIFICATIONS	43
8. PANEL FACILITIES	44

PIONEER ELECTRONIC CORPORATION 4-1, Meguro 1-Chome, Meguro-ku, Tokyo 153, Japan
PIONEER ELECTRONICS SERVICE INC. P.O. Box 1760, Long Beach, California 90801 U.S.A.
PIONEER ELECTRONICS OF CANADA, INC. 300 Allstate Parkway Markham, Ontario L3R 0P2 Canada
PIONEER ELECTRONIC [EUROPE] N.V. Haven 1087 Keetberglaan 1, 9120 Melsele, Belgium
PIONEER ELECTRONICS AUSTRALIA PTY. LTD. 178-184 Boundary Road, Braeside, Victoria 3195, Australia TEL: [03] 580-9911
© **PIONEER ELECTRONIC CORPORATION 1992**

SN APR. 1992 Printed in Japan 3754

1. EXPLODED VIEWS AND PARTS LIST

NOTES:

- The parts with an encircled number are generally unavailable because they are not in our Master Spare Parts List.
- The Δ mark found on some component parts indicates the importance of the safety factor of the part. Therefore, when replacing, be sure to use parts of identical designation.
- Parts marked by "⊙" are not always kept in stock. Their delivery time may be longer than usual or they may be unavailable.

1.1 EXTERIOR

Parts List

Mark	No.	Description	Part No.	Mark	No.	Description	Part No.
Δ	1	Strain relief	CM - 22B		41	Screw	BBZ30P080FZK
Δ	2	AC power cord	ADG1036		42	Screw	IBZ30P060FCC
Δ	3	FU601, FU602 Fuse (T2A)	REK - 103		43	Screw	IBZ30P080FCC
Δ	4	T1 Power transformer	RTT1201		44	Screw	IBZ30P100FCC
⊙	5	Mechanism unit	RYM1152		45	Screw	IBZ30P150FCC
	6	Absorb plate (B)	PNB1109		46	Screw	IBZ40P080FCC
	7	Washer	RBF1019		47	Screw	PMA30P060FCU
	8	Door spring	RBH1306		48	Jack nut	RBN - 006
	9	Door cushion	REB1174		49	Rivet	RBM - 003
	10	Protector	RED1020		101	MAIN unit	RWX1048
	11	Cord clammer	RNH - 184		102	CONTROL unit	RWZ2450
	12	Panel stay	RNT1139		103	BALANCE VR unit	RWZ2451
	13			104	FL unit	RWZ2656
	14	LED lens	AMR1160		105	FUNCTION unit	RWZ2453
	15	Sheet	RHC1028		106	BIAS unit	RWZ2657
	16			107	HEADPHONE unit	RWZ2455
	17	Lens S	PNW1893		108	Washer	RBF1017
	18	Counter reset knob	RAA1009		109	Acetate tape	REH1020
	19	Slide SW knob	RAC1562		110	Rubber spacer (A)	REB1057
	20	Power button	RAC1703		111	Rubber spacer	REB1192
	21	Function knob	RAC1704		112	Rubber spacer	REB1187
	22	Balance knob	RAC1705		113	Transformer sheet	REE1004
	23	FL filter	RAH1936		114	VR shaft	RLA1169
	24			115	Main chassis	RNB1059
	25	VR ring	RAT1011		116	Center stay	RNC1058
	26	Screw	FBT40P080FZK		117	Center stay	RNC1059
	27	Screw	BBZ40P080FZK		118	PS holder	RNE1185
	28	Door sheet	REB1191		119	PCB base	RNE1221
	29	VR knob assembly (A)	RXA1472		120	Binder	DNF1128
	30	Foot assembly	AMR1159		121	Bonnet bracket	RNE1470
	31			122	Joint	RNK1333
	32			123	PCB stud	RNL - 792
	33	Door lens	RAH1927		124	Name plate	PAN1035
	34	FL lens	RAH2019		125	Door	RNK1820
	35			126	
	36	Bonnet	RXX1505		127	Front panel	RAH2033
	37	Front panel assembly	RXX1510		128	Door panel	RAH2034
	38	Door assembly	RXX1514		129	Rear panel	RNA1564
	39	Screw	BBT30P100FZK				
	40	Screw	BBZ26P080FZK				

Exterior

A

B

C

D

A

B

C

D

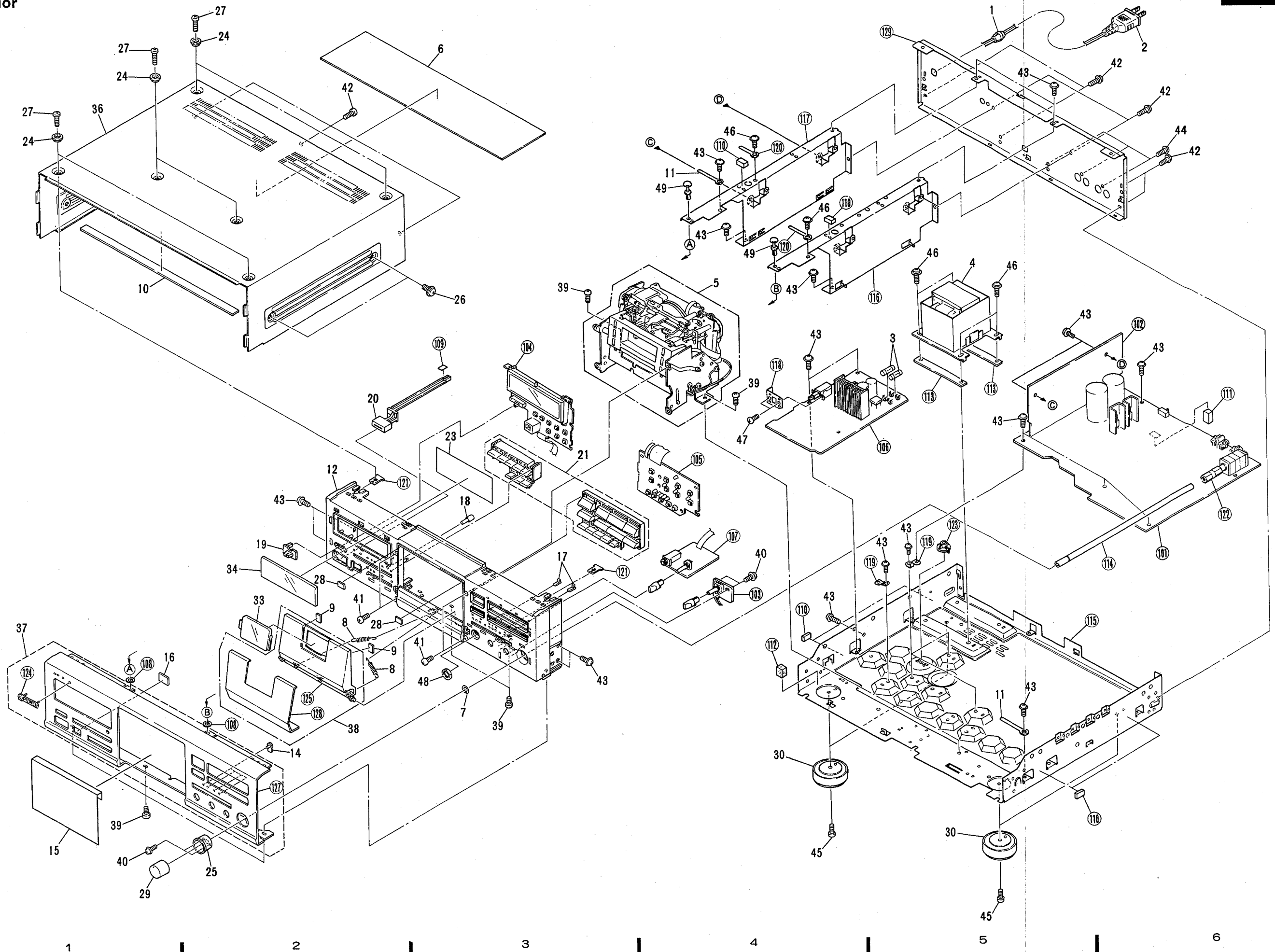

1.2 MECHANISM UNIT

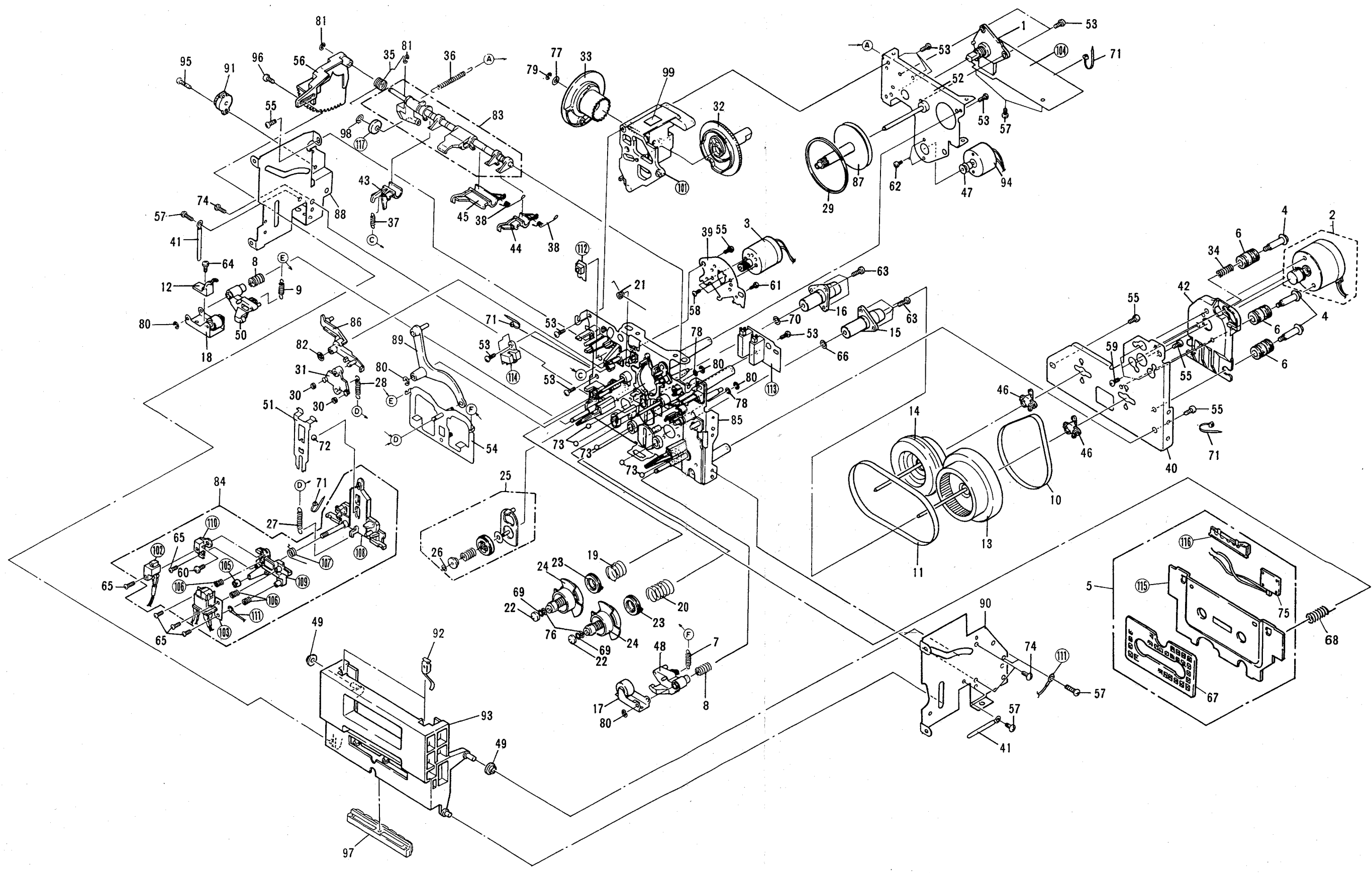

A
B
C
D

MATIC AND PCB CONNECTIONS DIAGRAMS

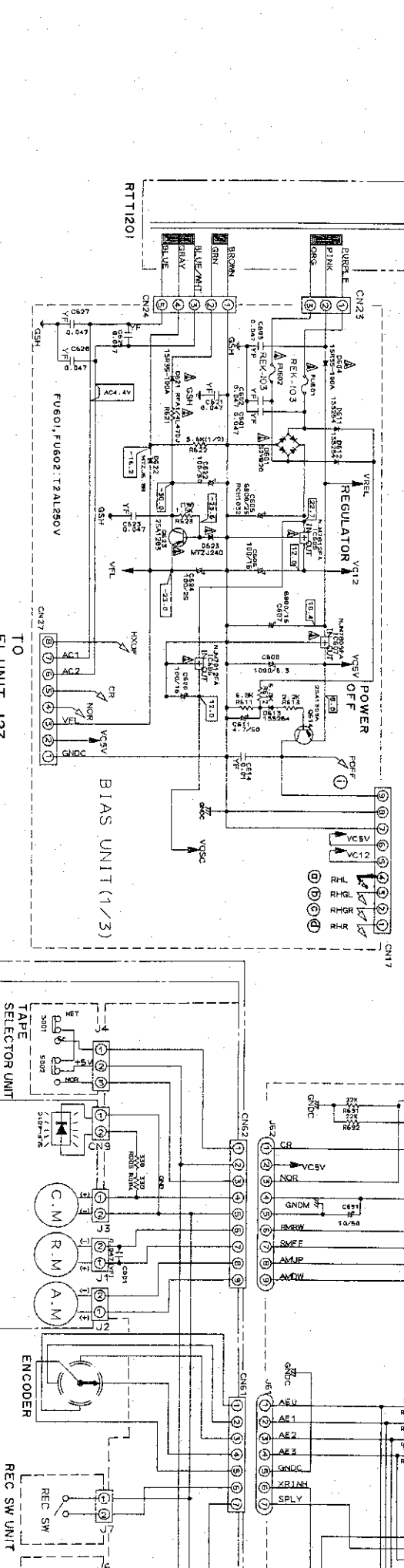
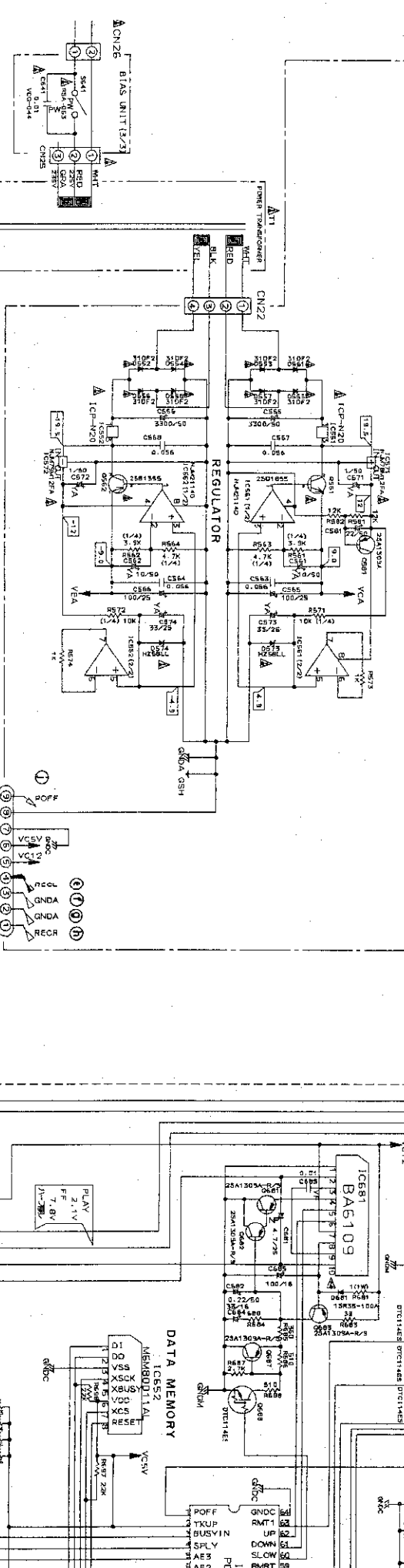
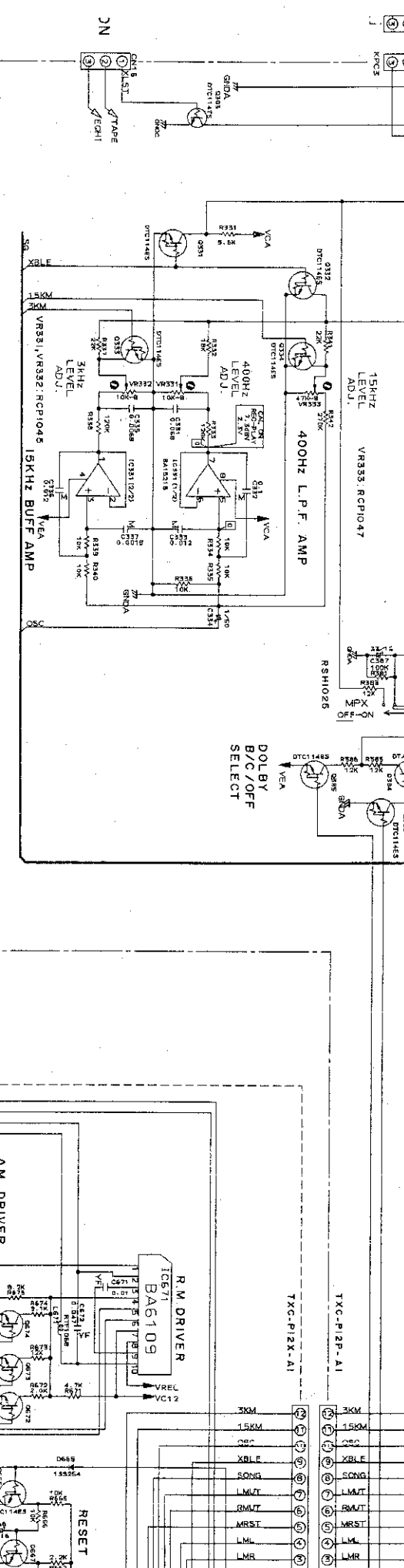
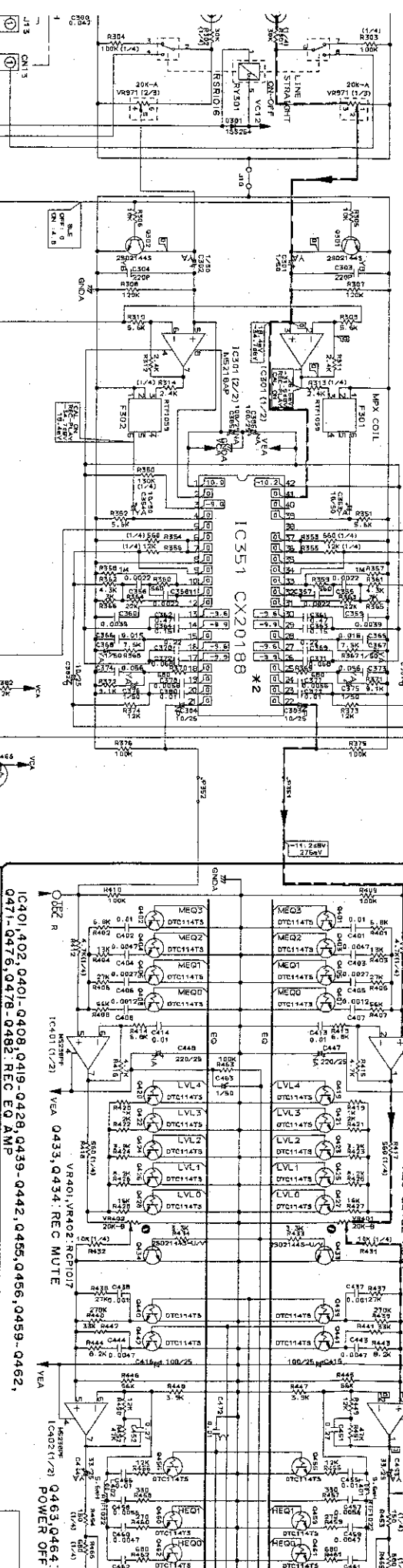
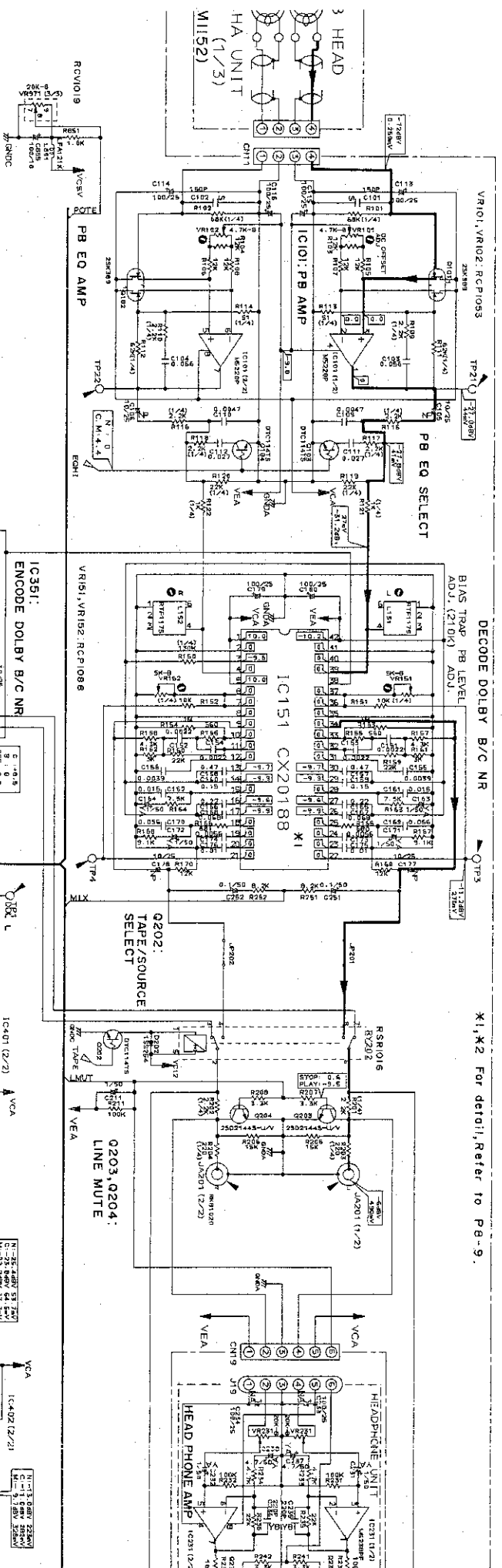

*1, *2 For detail, Refer to Pg-9.

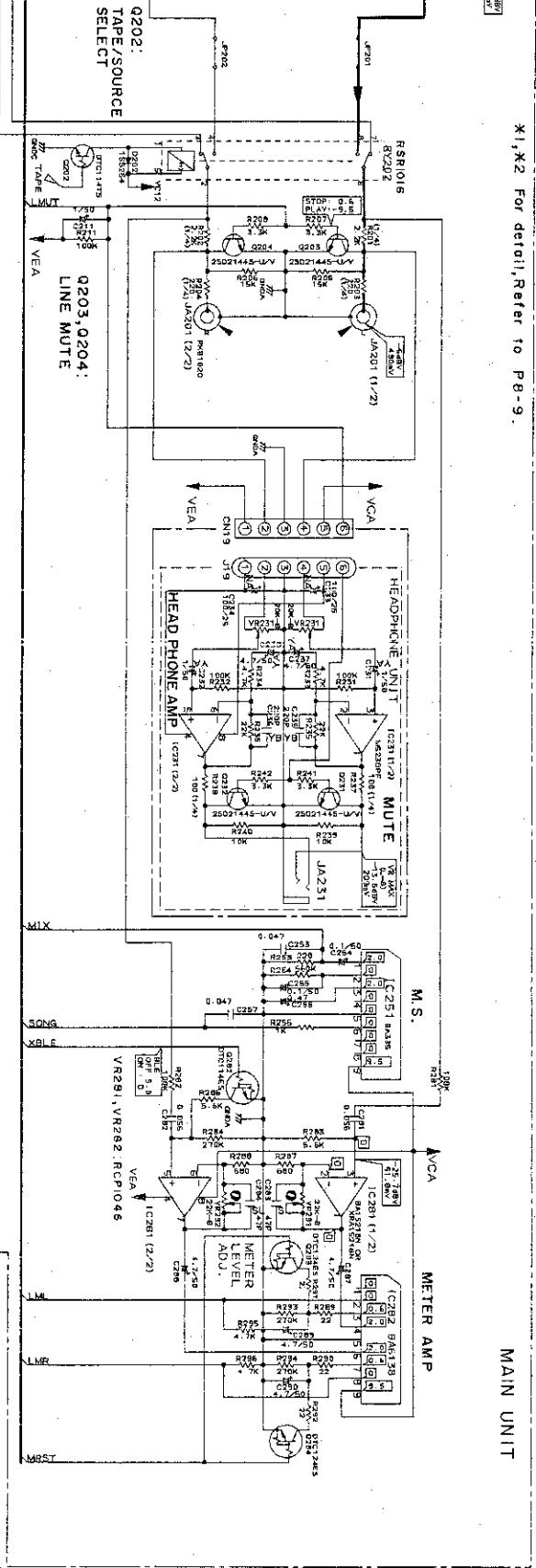

1. RESISTORS:
Indicated in Ω, 1/4W, 1/5W, 1/8W, 1/5W, ±5% tolerance unless otherwise noted. K: KΩ, M: MΩ, (F): ±1%, (G): ±2%, (X): ±10%, (N): ±20% tolerance.
 2. CAPACITORS:
Indicated in capacity (μF) / voltage (V) unless otherwise noted. p: pF.
Indication without voltage is 50V except electrolytic capacitor.
 3. VOLTAGE CURRENT:
mA: DC current in stop mode.
 4. OTHERS:
○: Signal route.
⊕: Adjusting point
The Δ mark found on some component parts indicates the importance of the safety factor of the part. Therefore, when replacing, be sure to use parts of identical designation.
※ marked capacitors and resistors have parts numbers.
- This is the basic schematic diagram, but the actual circuit may vary due to improvements in design.
- MEASUREMENT POINT
PLAYBACK SIGNAL
RECORDING SIGNAL

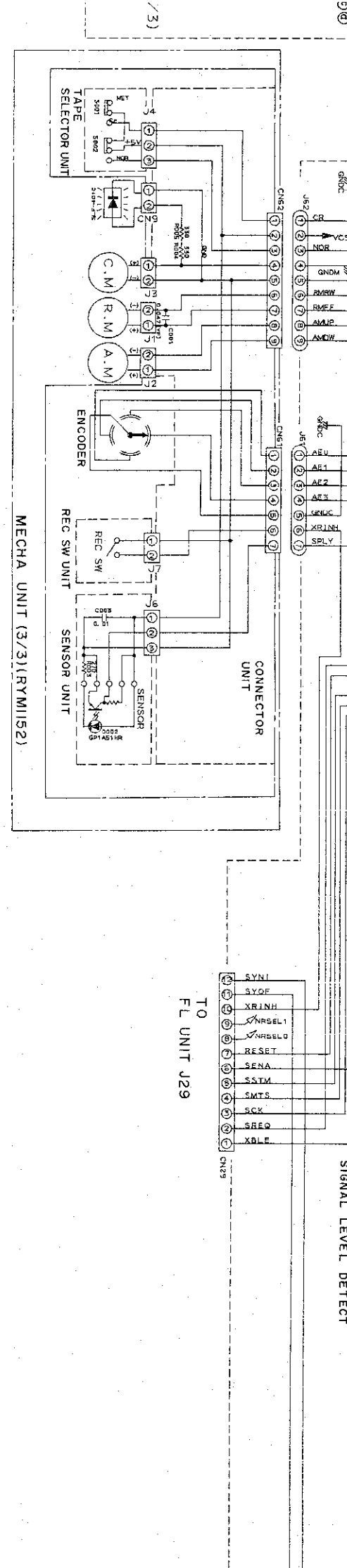
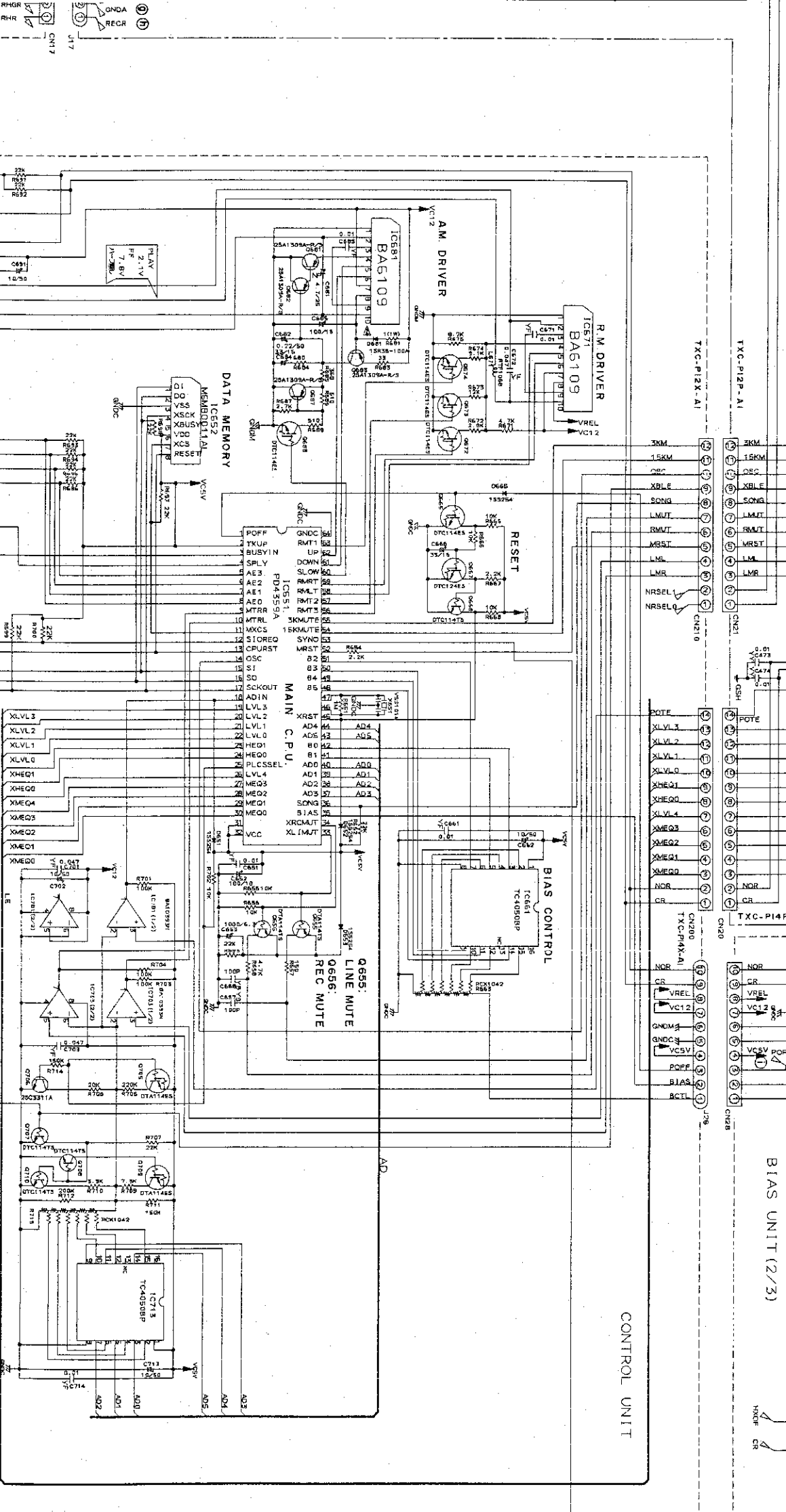
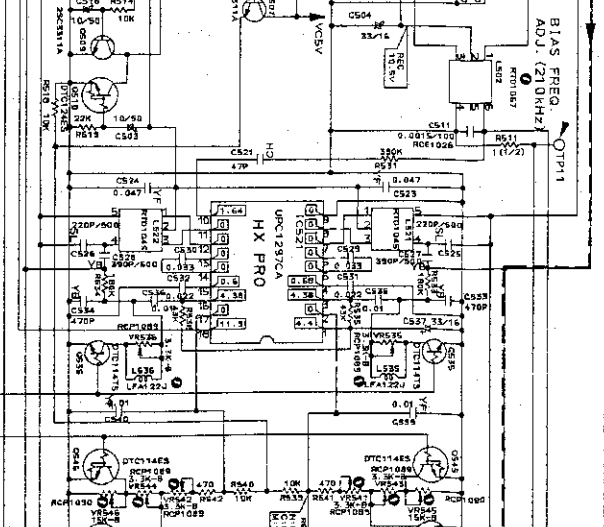
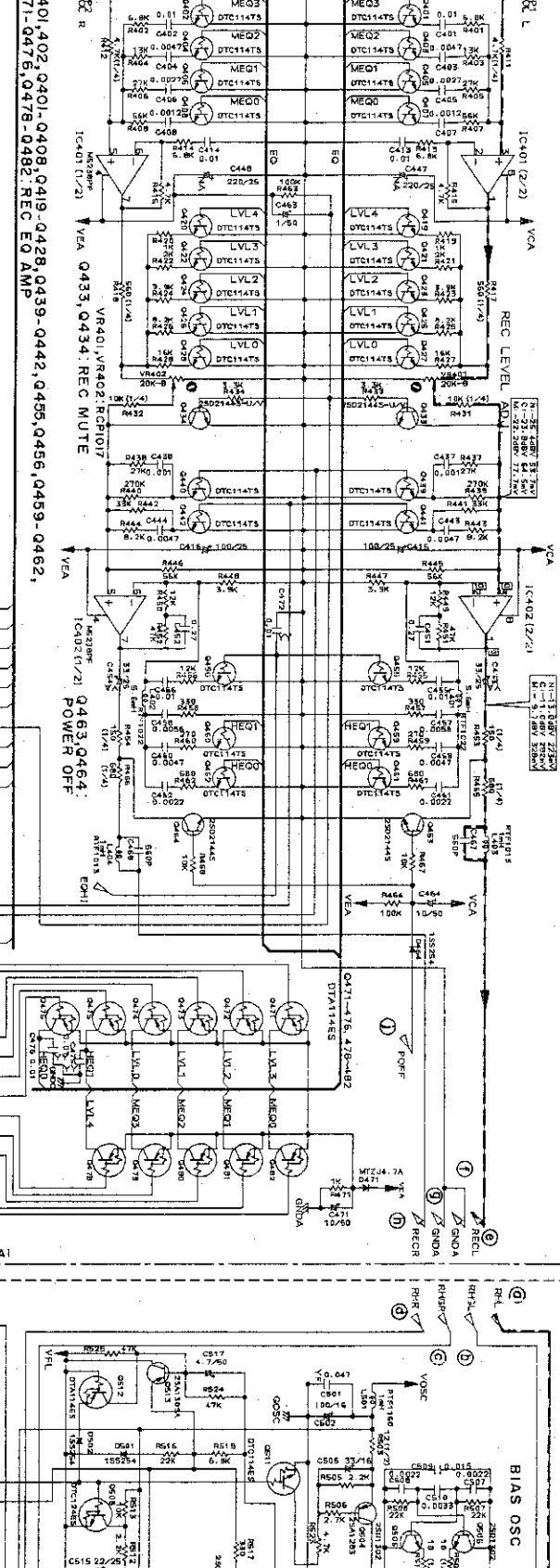

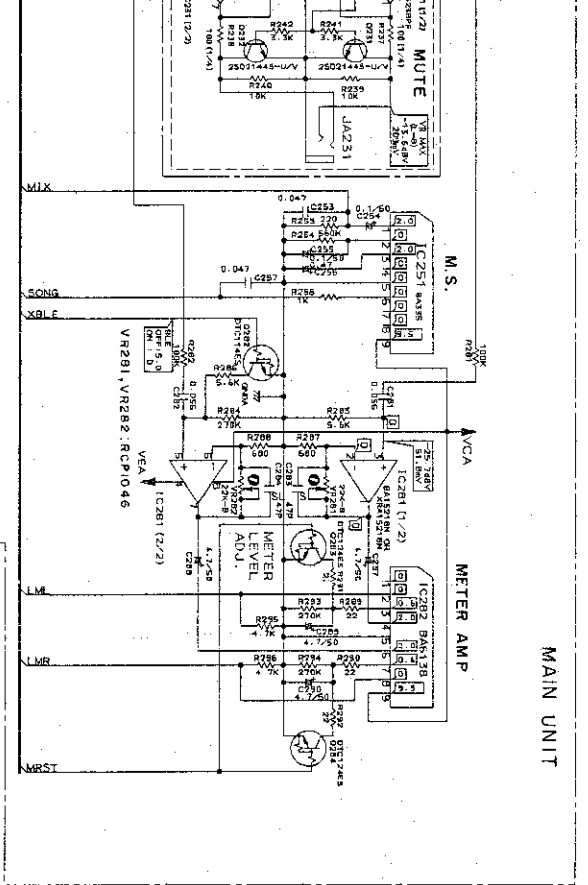

MAIN UNIT

- RESISTORS:
Indicated in 0, 1/4W, 1/8W, 1/2W, ±5% tolerance unless otherwise noted. K: k.Ω, M: M.Ω, (F): ±1%, (G): ±2%, (X): ±10%, (M): ±20% tolerance.
- CAPACITORS:
Indicated in capacity (μF) / voltage (V) unless otherwise noted. p: pF.
Indication without voltage is 50V except electrolytic capacitor.
- VOLTAGE CURRENT:
V: DC voltage (V) in stop mode.
mA: DC current in stop mode.
- OTHERS:
Δ: Adjusting point
The Δ mark found on some component parts indicates the importance of the safety factor of the part. Therefore, when replacing, be sure to use parts of identical designation.
* marked capacitors and resistors have parts numbers.

This is the basic schematic diagram, but the actual circuit may vary due to improvements in design.

MEASUREMENT POINT
PLAYBACK SIGNAL
RECORDING SIGNAL

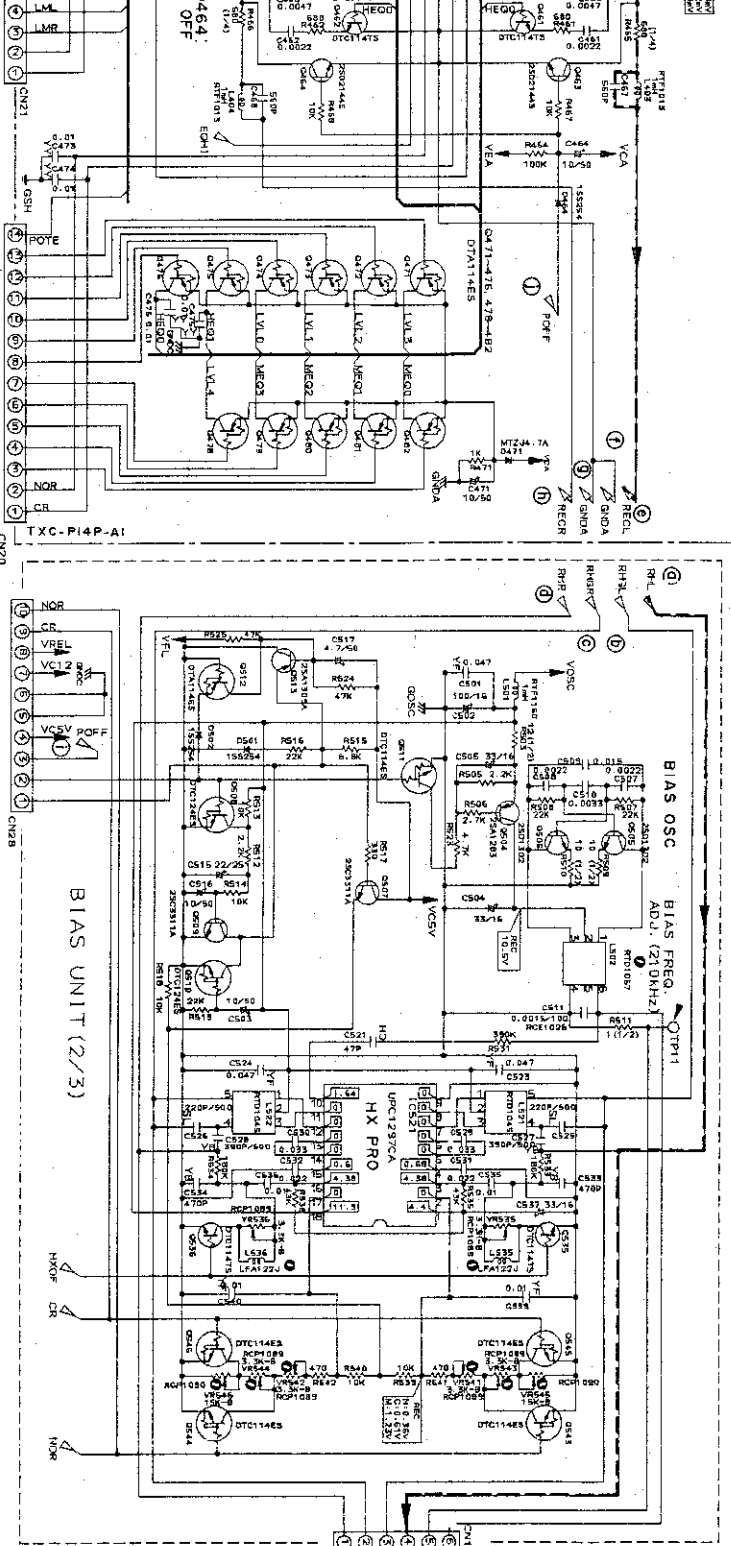

BIAS UNIT (2/3)

- SWITCHES (The underlined indicates the switch I)
- | | |
|-------------------------|-------------------|
| MAIN UNIT | FUNCTION UNIT |
| S381 : MPX ONN - OFF | S781 : LINE STRAI |
| | S782 : DOLBY - NR |
| | S783 : IX PRO |
| | S784 : MONITOR |
| BIAS UNIT | S785 : REC/MUTE |
| S641 : POWER ONN - OFF | S786 : PAUSE |
| | S787 : REC |
| FL UNIT | S788 : OPEN/CLS |
| S721 : BLE (FLAT) S/C | S789 : FF |
| S722 : METER RANGE | S790 : PLAY |
| S723 : RESET | S791 : REW |
| S724 : BIAS DOWN | S792 : STOP |
| S725 : PEAK MODE | S793 : CD SYNC |
| S726 : COUNTER MODE | |
| S727 : BIAS UP | |
| S728 : TAPE RETURN | |
| S729 : DISPLAY OFF | |
| S735 : PLAY - OFF - REC | |

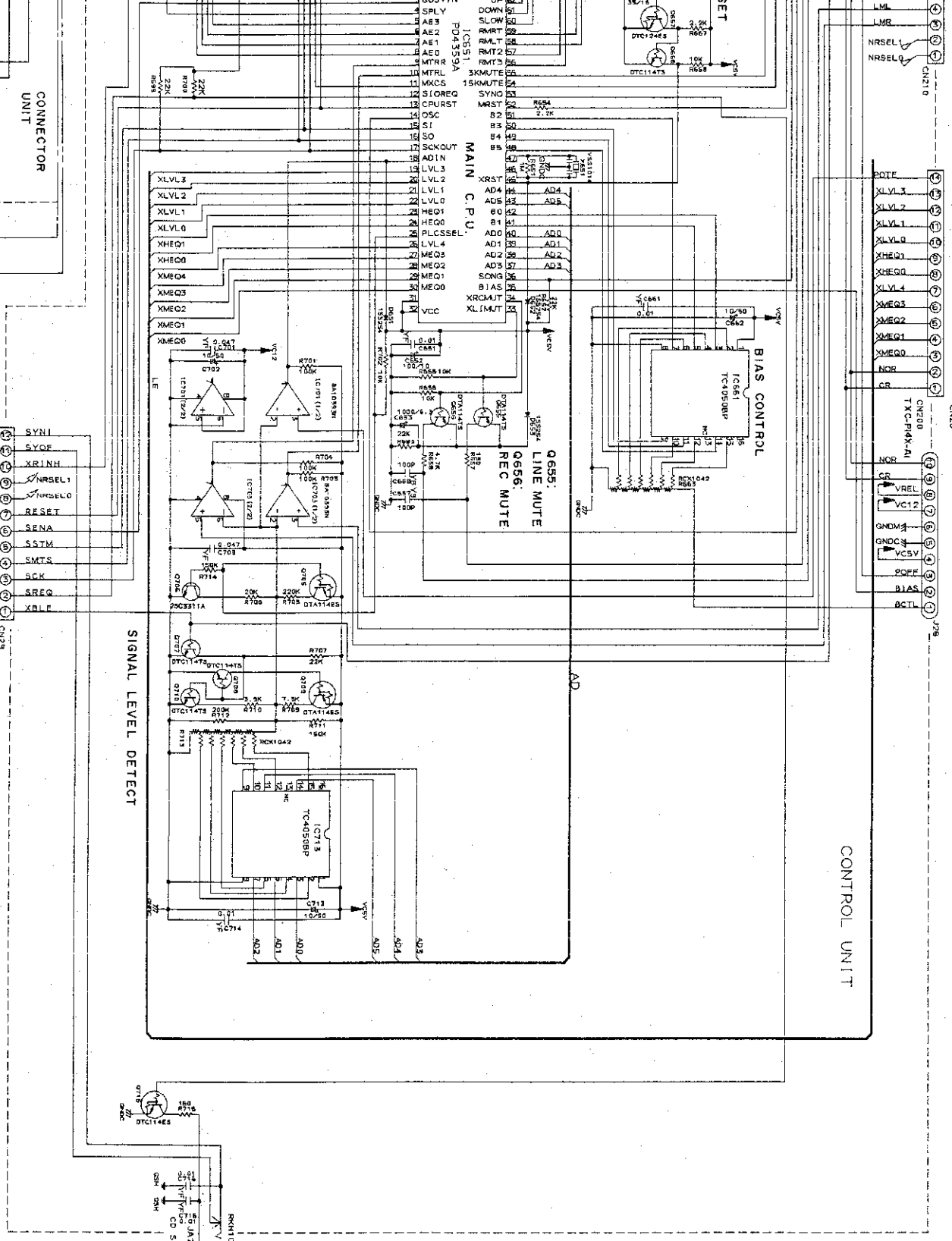

CONTROL UNIT

TO FL UNIT J29

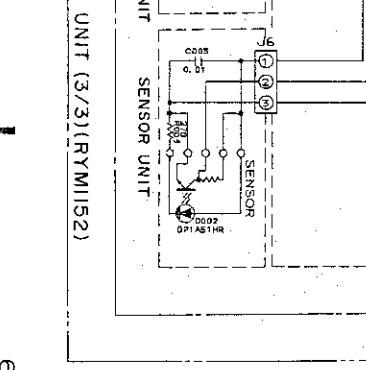

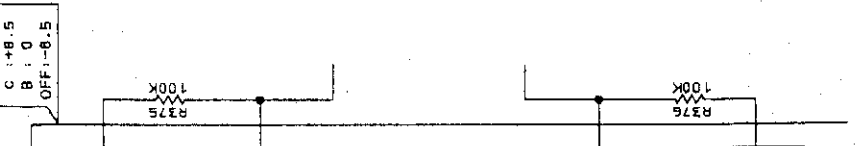

Parts List

Mark No.	Description	Part No.
1	Rotary encoder	RSX1004
2	Capstan motor assembly	RXM1016
3	Reel motor assembly	RXM1018
4	Step screw	RBA1074
5	Cassette plate assembly	RXX1064
6	Insulator	RFB1069
7	Pinch spring	RBL - 028
8	Pinch thrust spring	RBL - 030
9	Sub - pinch spring	RBL - 098
10	Capstan belt	REB - 501
11	Capstan belt (A)	REB - 509
12	Tape guide	RNK1823
13	Flywheel assembly	RXA1374
14	Sub - flywheel assembly	RXA1375
15	Metal holder assembly(A)	RXA1426
16	Metal holder assembly(B)	RXA1343
17	Pinch roller arm (R) assembly	RXB - 876
18	Pinch roller arm (A) assembly	RXB - 877
19	BT spring (A)	RBL - 031
20	BT spring (B)	RBL - 032
21	Idler pressure spring	RBL - 033
22	Reel shaft cap (B)	RNK - 815
23	BT disk assembly	RXB - 751
24	Reel base assembly	RXB - 874
25	Take - up idler assembly	RXB - 875
26	Washer	RBF - 065
27	Head base spring	RBL - 037
28	Brake spring	RBL - 038
29	Drive belt	REB1182
30	Brake shoe	REB - 511
31	Brake	RNL - 723
32	Cam gear	RNK1640
33	Side cam gear	RNK1785
34	Insulator spring	RBH1226
35	Eject spring	RBL - 039
36	Half set arm spring	RBL - 040
37	REC functioning spring	RBL - 041
38	Detection functioning spring	RBL - 042
39	Reel motor mounting plate	RNE1169
40	Flywheel holder	RNH - 304
41	Cord clamper	RNH - 184
42	Motor bracket	RNK1497
43	REC detector arm	RNL - 733
44	Chrom detector arm	RNL - 734
45	Metal detector arm	RNL - 735
46	Thrust holder	RNL - 743
47	Motor pulley	PNW1634
48	Pressure arm (R)	RNL - 725
49	Collar	RNL - 742
50	Pressure arm (L)	RNL - 726

Mark No. Description Part No.

51	Head base set spring	RBL - 026
52	Gear chassis assembly	RXA1171
53	Screw	BEZ26P080FZK
54	Pinch base assembly	RXB - 878
55	Screw	BEZ30P080FZK
56	Eject lever	RNK1763
57	Screw	BCZ30P080FMC
58	Screw	BMZ26P030FZK
59	Screw	BMZ26P040FMC
60	Screw	BMZ26P060FZK
61	Screw	BMZ30P080FZK
62	Screw	FMZ30P040FMC
63	Screw	PMZ26P050FZK
64	Screw	PMZ26P060FZK
65	Screw	PMZ20P080FZK
66	Washer	RBF - 030
67	Stabilizer (B)	REB1038
68	Cassette plate spring	RBL - 059
69	Washer	RBF - 076
70	Washer	RBF1040
71	Binder	REC - 371
72	Steel ball (3mm)	REF - 022
73	Steel ball (4mm)	REF - 023
74	Screw	VCT30P060FZK
75	LED (D3)	SLF - 401C
76	Washer	WA21D040D013
77	Washer	WA26N070W040
78	Washer	WA32D080D050
79	E ring	YE20FUC
80	E ring	YE25FUC
81	E ring	YE30FUC
82	Snapping	YS24FBT
83	Shift shaft assembly	RXB - 885
84	Head base assembly	RXX1443
85	Mechanism chassis assembly	RXA1366
86	Brake lever	RNK1638
87	Second pulley assembly	RXA1350
88	Door frame (L)	RNE1475
89	Pinch lever assembly	RXA1360
90	Door frame (R)	RNE1476
91	Damper assembly	VXA1153
92	Half pressure spring	RBK1004
93	Door pocket	RNK1764
94	Loading motor	VXM1034
95	Screw	PBZ20P060FMC
96	Screw	BBZ20P060FMC
97	Stabilizer	REB1161
98	Washer	RBF - 057
99	Acetate tape (B)	REH1003
101	Gear base assembly	RXB - 882
102	E head	RPB1046
103	R & P head	RPB1029
104	Connector unit	RWZ2459
105	Adjustment nut	RBA1047
106	Head adjustment spring (C)	RBL - 034
107	Height spring	RBL - 036
108	Head base	RNG - 334
109	Sub - head base	RNG - 335
110	E head base	RNG1083
111	Earth lead assembly	RDF - 001
112	REC switch unit	RWZ2457
113	Tape selector unit	RWZ2458
114	Sensor unit (B)	RWZ2460
115	Cassette plate	RAH1306
116	Lead cover	RNL - 793
117	Shift roller	RNL - 731

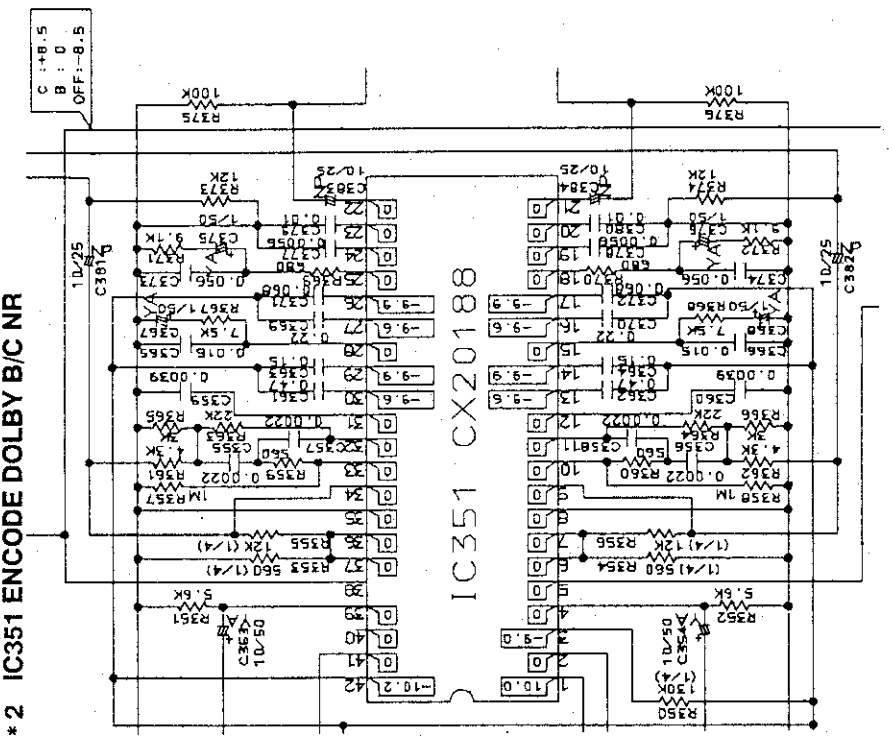

* 2 IC351 CX20188 ENCODE DOLBY B/C NR

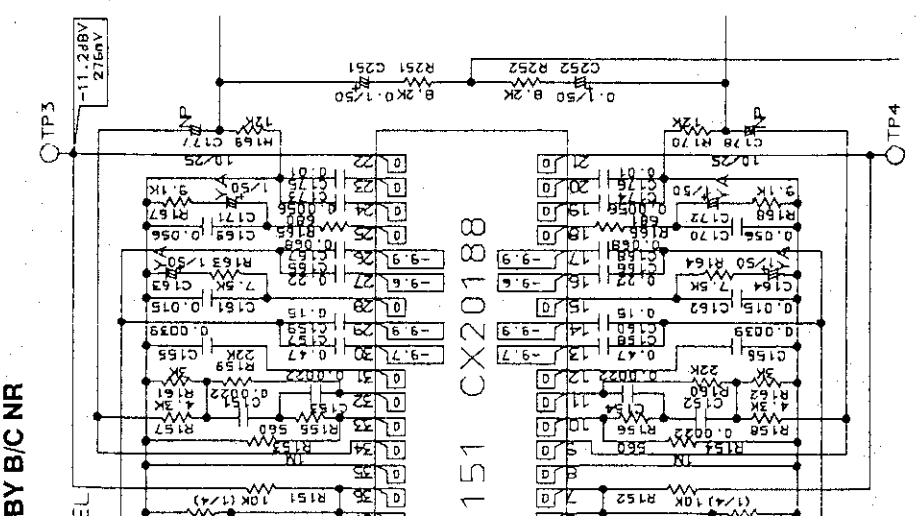

DOLBY B/C NR

Mark No. Description Part No.

101	Gear base assembly	RXB-882
102	E head	RPB1046
103	R & P head	RPB1029
104	Connector unit	RWZ2459
105	Adjustment nut	RBAl047
106	Head adjustment spring	RBL-034
107	Height spring	RBL-036
108	Head base	RNG-334
109	Sub-head base	RNG-335
110	E head base	RNG1033
111	Earth lead assembly	RDF-001
112	REC switch unit	RWZ2457
113	Tape selector unit	RWZ2458
114	Sensor unit (B)	RWZ2460
115	Cassette plate	RAH1306
116	Lead cover	RNL-793
117	Shift roller	RNL-731

2. PACKING

NOTES:

- The parts with an encircled number are generally unavailable because they are not in our Master Spare Parts List.
- The Δ mark found on some component parts indicates the importance of the safety factor of the part. Therefore, when replacing, be sure to use parts of identical designation.
- Parts marked by "⊙" are not always kept in stock. Their delivery time may be longer than usual or they may be unavailable.

Parts List

Mark No.	Description	Part No.
1	Pad (F)	RHA1095
2	Pad (R)	RHA1096
3	Packing case	RHG1356
4	Sheet	RHX1007
5	Control cord	RDE1031
6	Operating instructions (English/French)	RRE1057
7	Operating instructions (German/Italian/Dutch/Swedish/Spanish/Portuguese)	RRD1126
8	Connection cord assembly	RDE1002
9	Sheet	PHC1057
10	Connection cord	RDE-010
101	Vinyl bag	RHL-018

3. BLOCK DIAGRAM

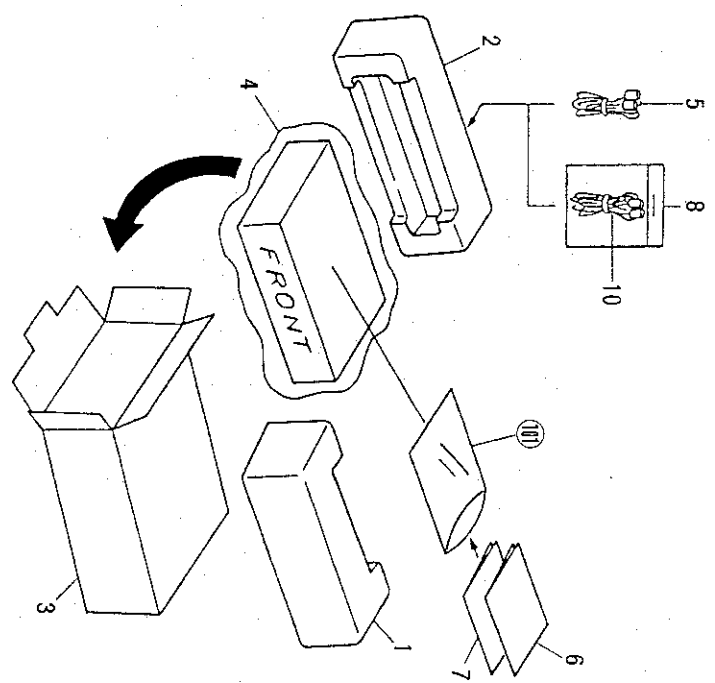
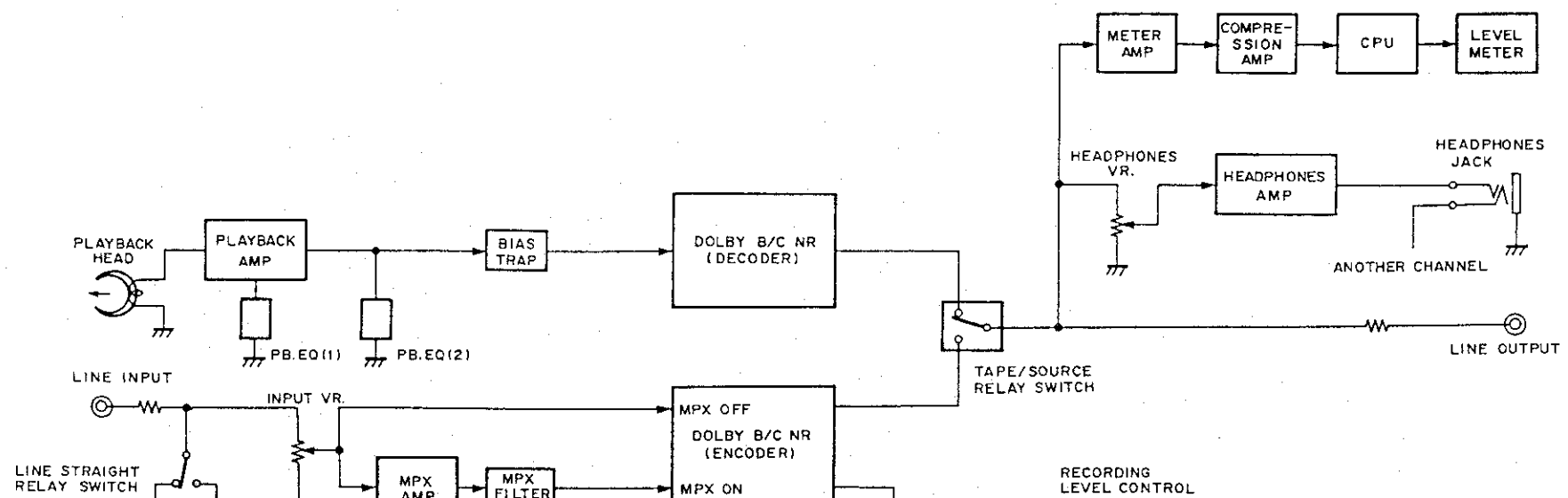

* 1 IC151 ENCODE DOLBY B/C NR

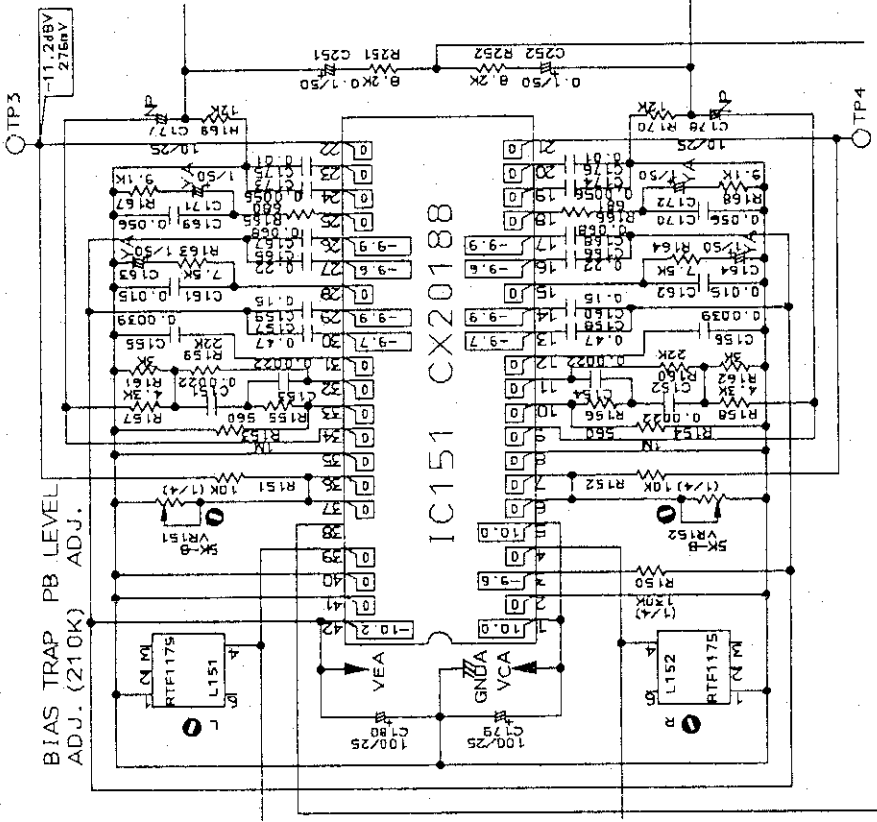

* 2 IC351 ENCODE DOLBY B/C NR

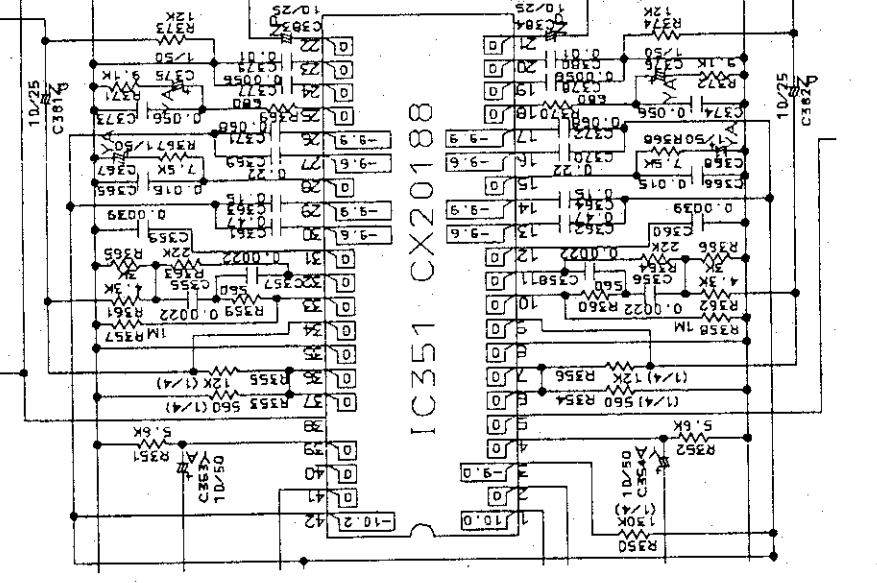

3. BLOCK DIAGRAM

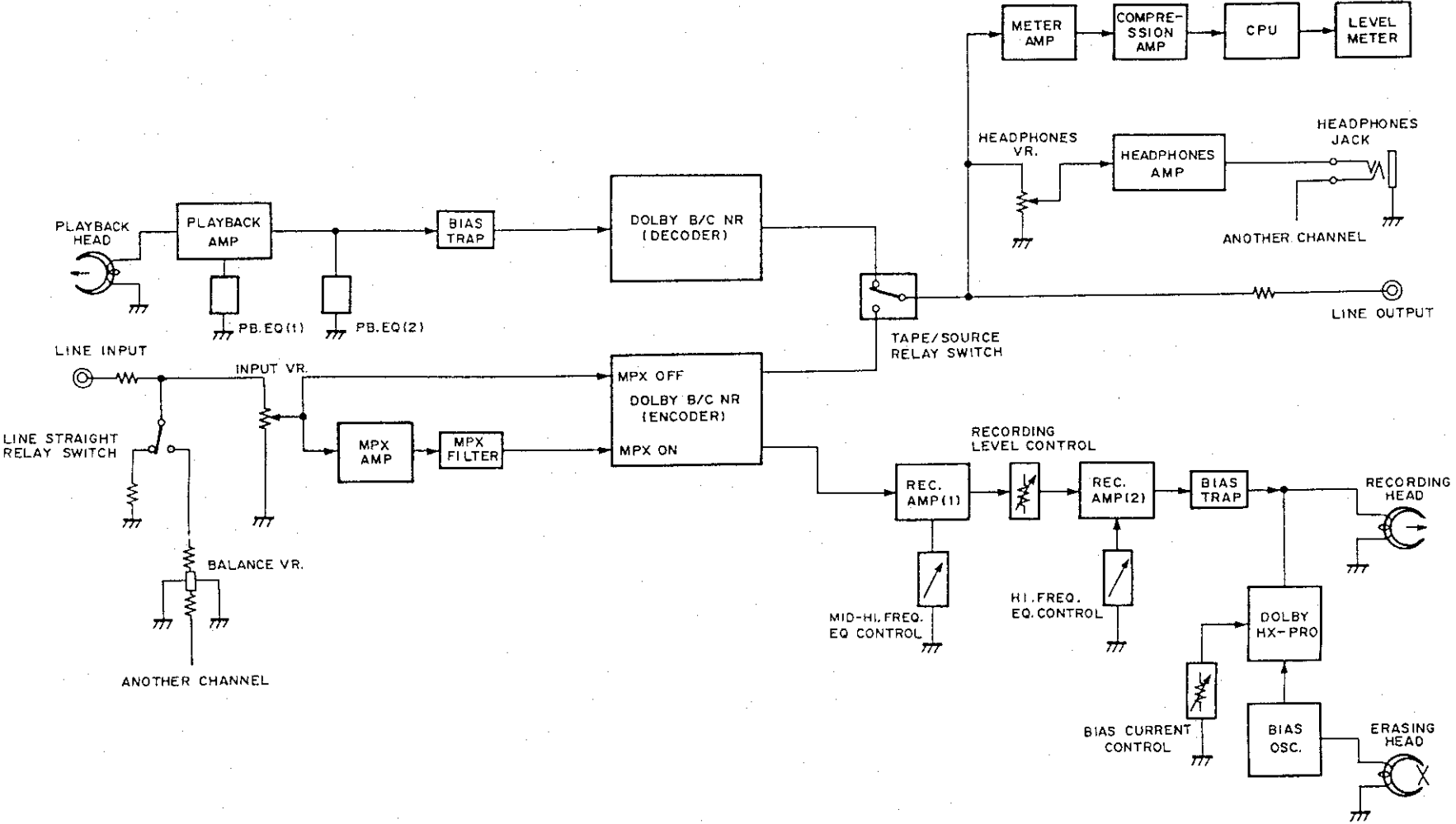

2. PACKING

NOTES:

- The parts with an encircled number are generally unavailable because they are not in our Master Spare Parts List.
- The Δ mark found on some component parts indicates the importance of the safety factor of the part. Therefore, when replacing, be sure to use parts of identical designation.
- Parts marked by “ \odot ” are not always kept in stock. Their delivery time may be longer than usual or they may be unavailable.

Parts List

Mark No.	Description	Part No.
1	Pad (F)	RHA1095
2	Pad (R)	RHA1096
3	Packing case	RHG1356
4	Sheet	RHX1007
5	Control cord	RDE1031
6	Operating instructions (English/French)	RRE1057
7	Operating instructions (German/Italian/Dutch/ Swedish/Spanish/Portuguese)	RRD1126
8	Connection cord assembly (Japanese)	RDE1002
9	Sheet	PHC1057
10	Connection cord	RDE-010
101	Vinyl bag	RHL-018

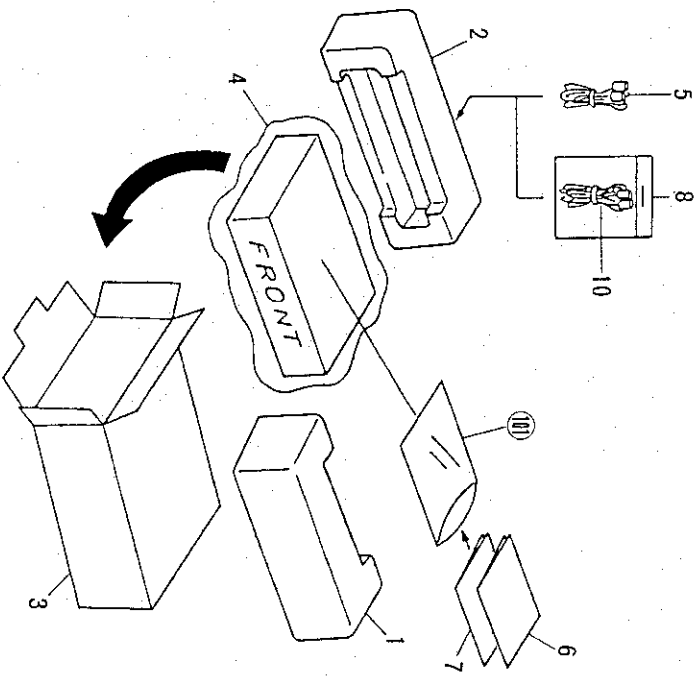

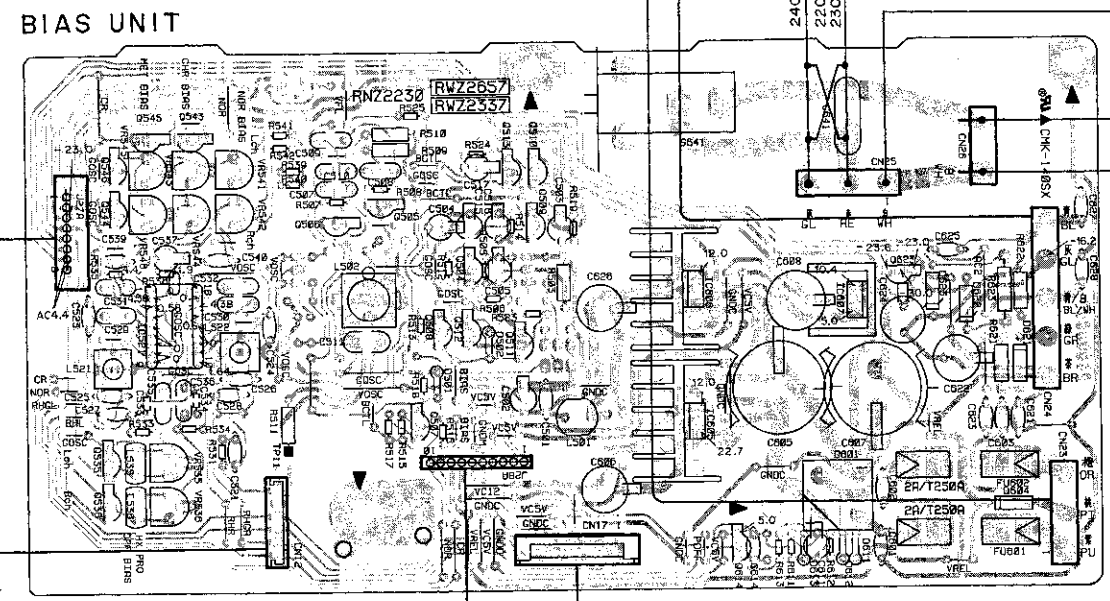
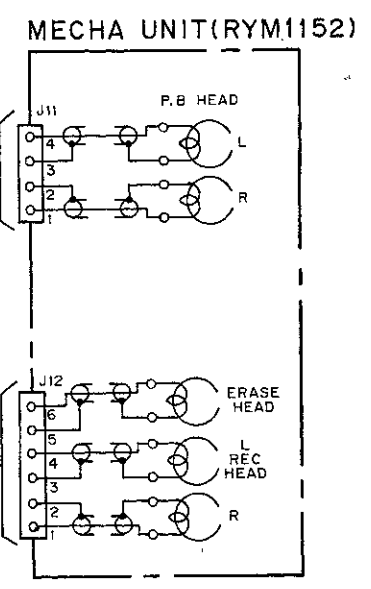
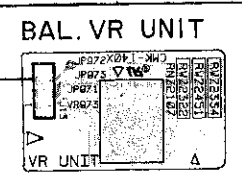
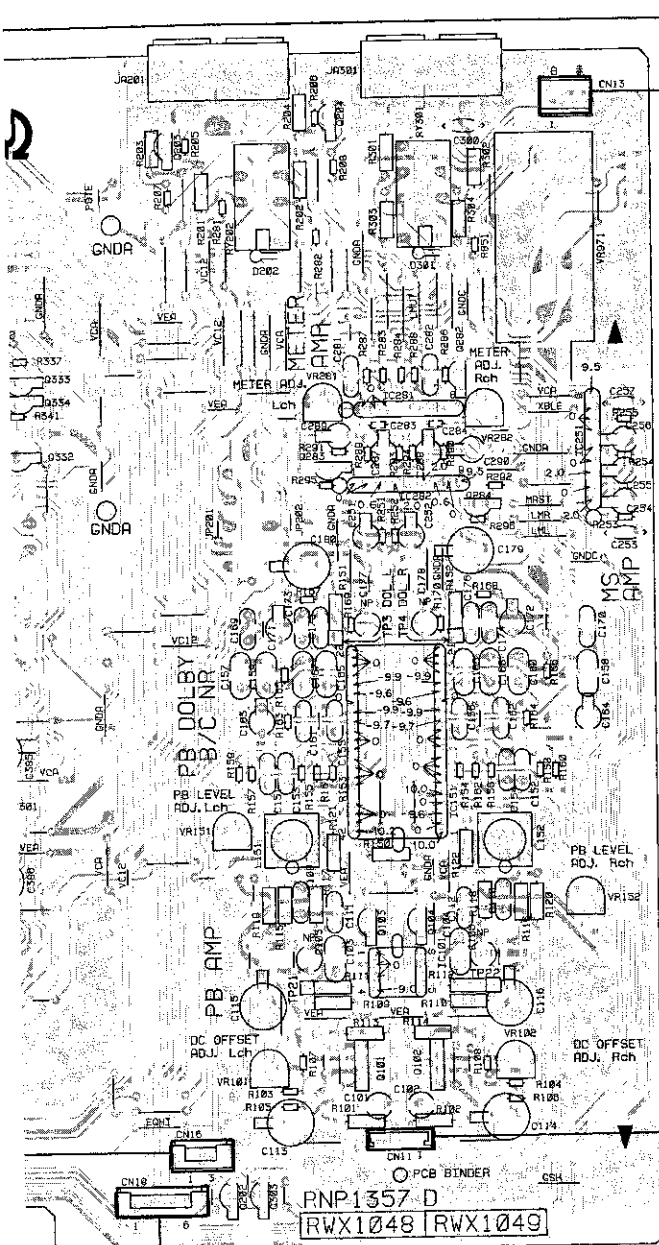

Line Voltage Selection

- Line voltage can be changed with the following steps.
1. Disconnect the AC power cord.
 2. Remove the Bonnet case.
 3. Change the connection of the power transformer lead wire.
 4. Stick the line voltage label on the rear panel.

Port NO.	Description
AAx-193	220V label
AAx-192	240V label

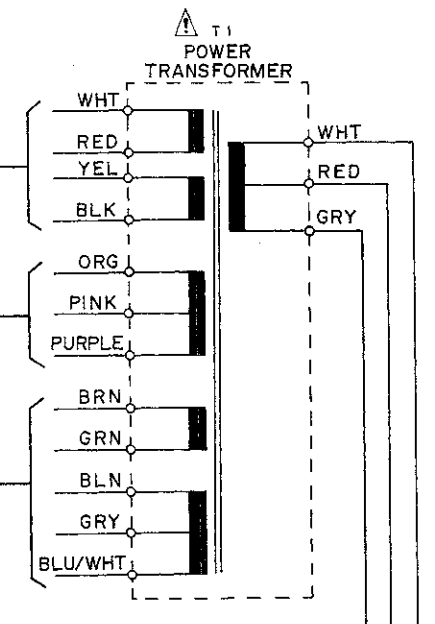

P.C.B. pattern diagram indication	Corresponding part symbol	Part name
		Transistor
		FET
		Diode
		Zener diode
		LED
		Varactor
		Tact switch
		Inductor
		Coil
		Transformer
		Filter
		Ceramic capacitor
		Mylar capacitor
		Styro capacitor
		Electrolytic capacitor (Non polarized)
		Electrolytic capacitor (Noiseless)
		Electrolytic capacitor (Polarized)
		Electrolytic capacitor (Polarized)
		Power capacitor
		Semi-fixed resistor
		Resistor array
		Resistor
		Resonator
		Thermistor

1. This P.C.B. connection diagram is viewed from the parts mounted side.
2. The parts which have been mounted on the board can be replaced with those shown with the corresponding wiring symbols listed in the above Table.
3. The capacitor terminal marked with shows negative terminal.
4. The diode marked with shows cathode side.
5. The transistor terminal marked with shows emitter.

A

B

C

D

A

B

C

D

AC 250 - 230V
50/60Hz
AC CORD
POWER

VOSS
-VOSS

VOSS
-VOSS

VOSS
-VOSS

VOSS
-VOSS

VOSS
-VOSS

VOSS
-VOSS

VOSS
-VOSS

VOSS
-VOSS

VOSS
-VOSS

VOSS
-VOSS

VOSS
-VOSS

VOSS
-VOSS

VOSS
-VOSS

VOSS
-VOSS

VOSS
-VOSS

VOSS
-VOSS

VOSS
-VOSS

VOSS
-VOSS

VOSS
-VOSS

VOSS
-VOSS

VOSS
-VOSS

VOSS
-VOSS

VOSS
-VOSS

VOSS
-VOSS

VOSS
-VOSS

1. Disconnect the AC power cord.
 2. Remove the Bonnet case.
 3. Change the connection of the power transformer lead wire.
 4. Stick the line voltage label on the rear panel.
- Line voltage can be changed with the following steps.
- Line Voltage Selection

Port No.	Description
AA1-133	230V Label
AA1-132	250V Label

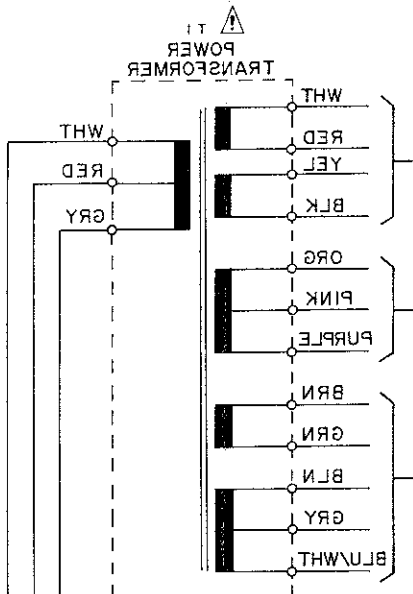

MECHA UNIT(RYM1125)

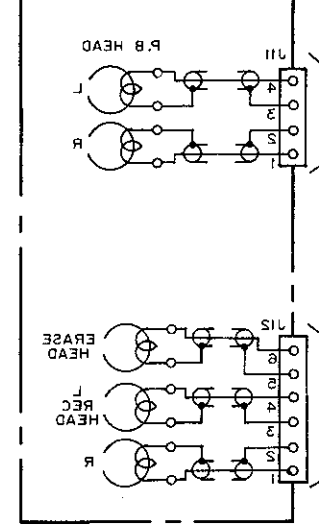

BIAS UNIT

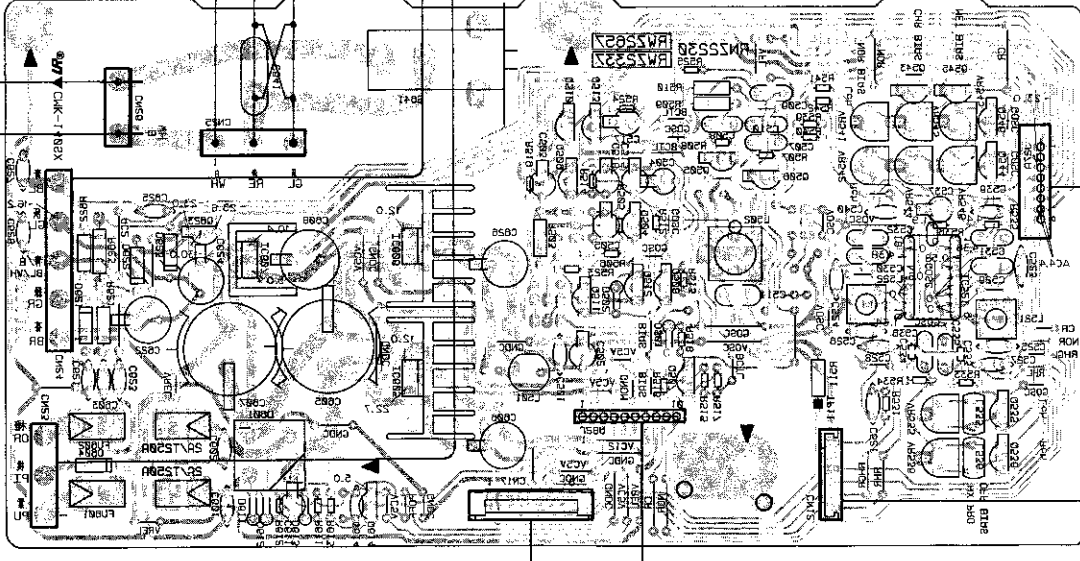

BAL. VR UNIT

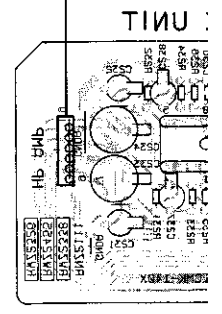
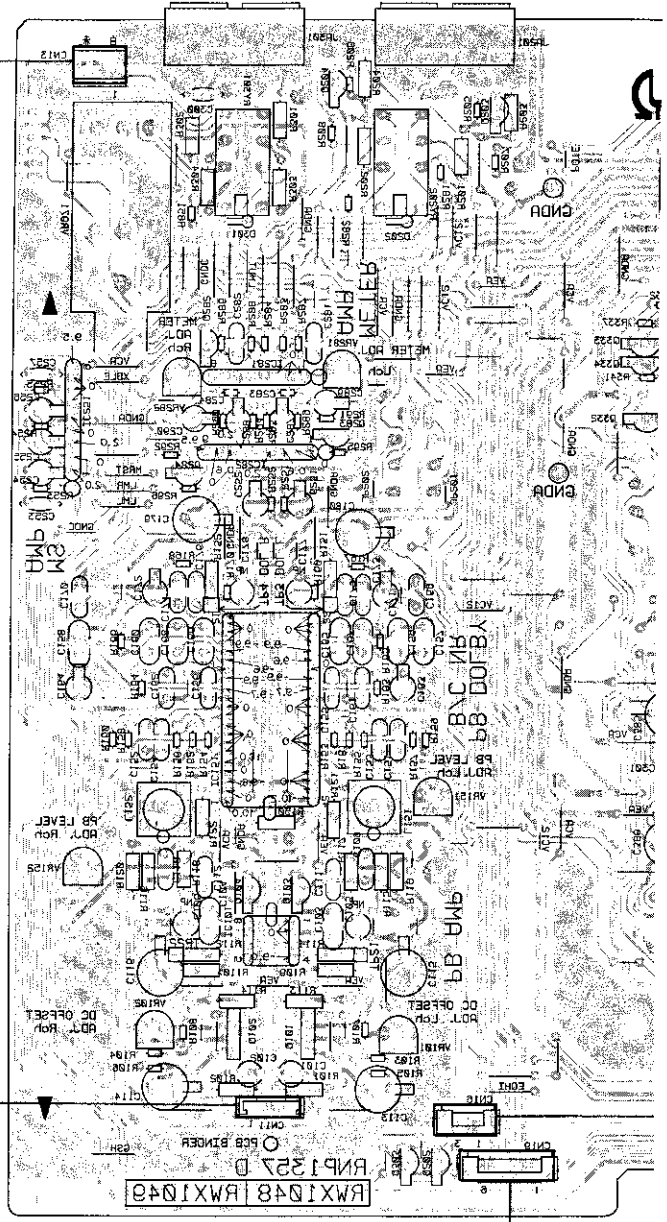

UNIT

● View from soldering side

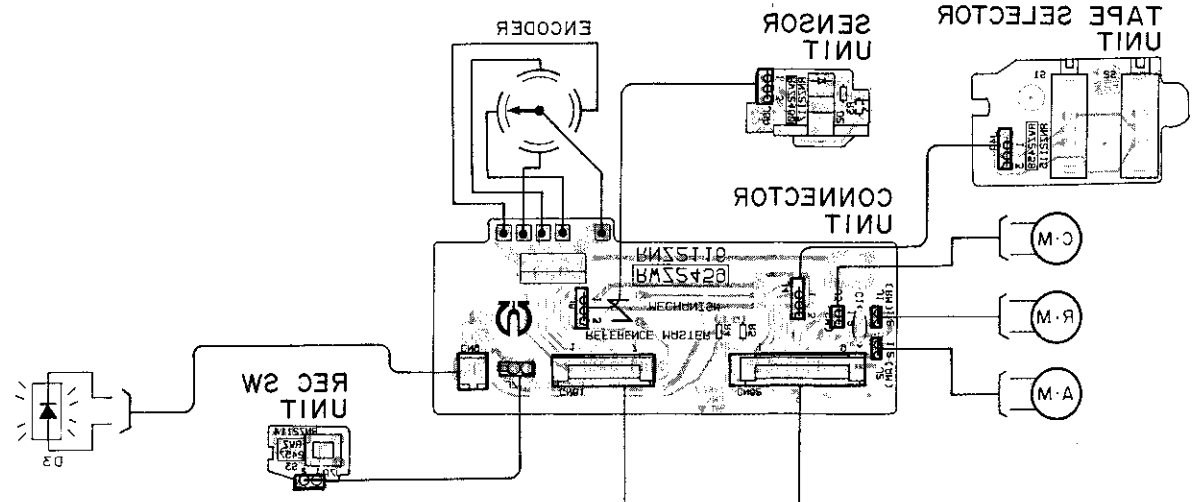
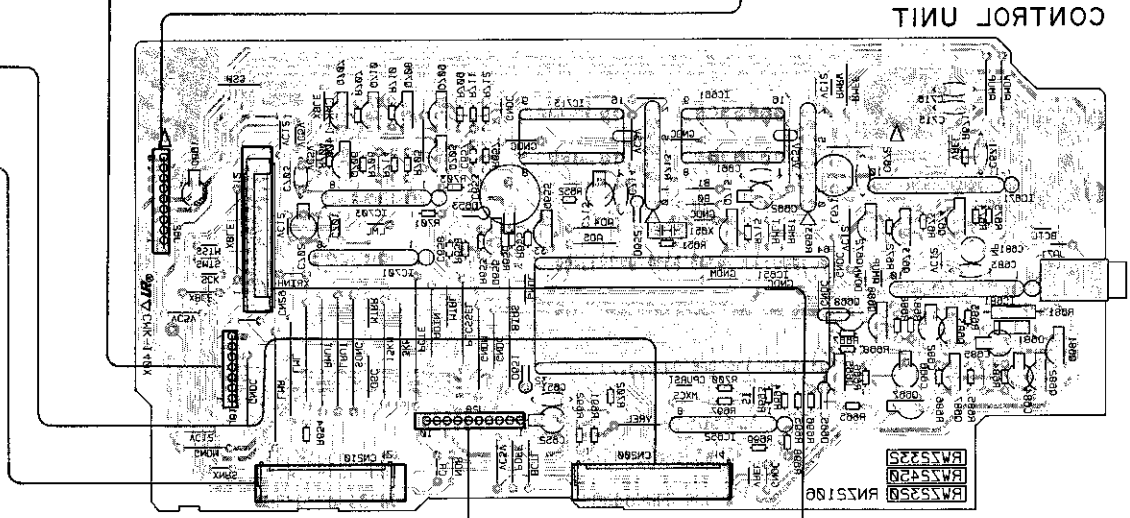
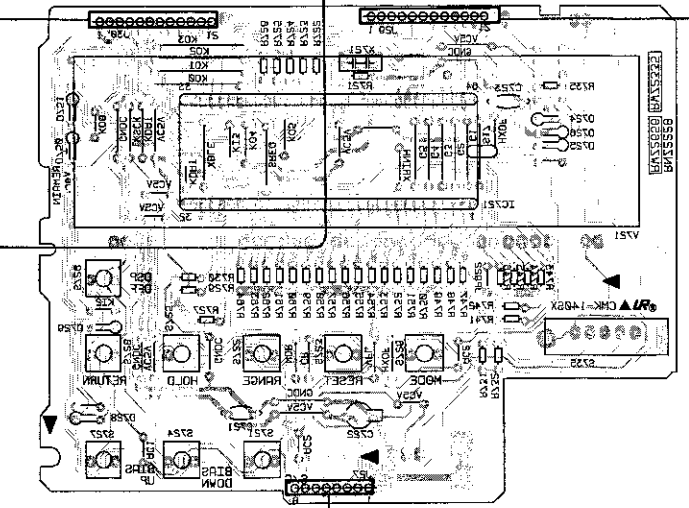
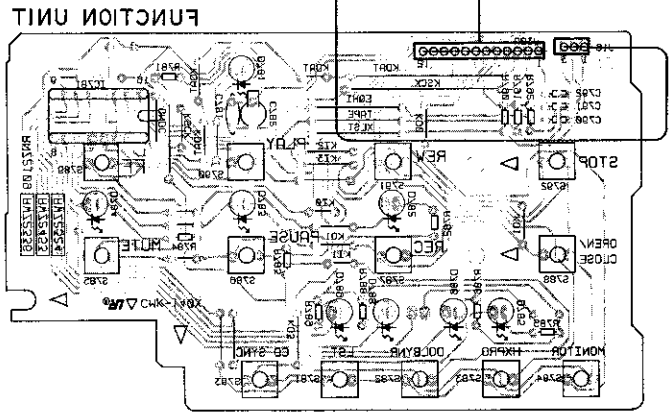
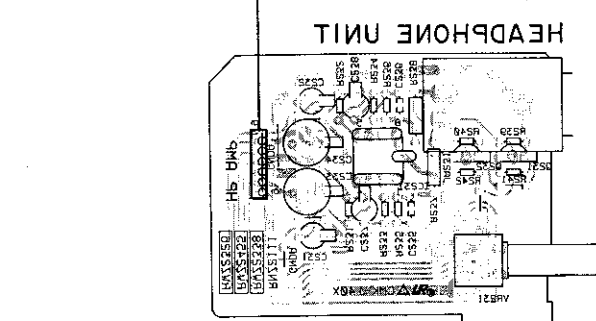
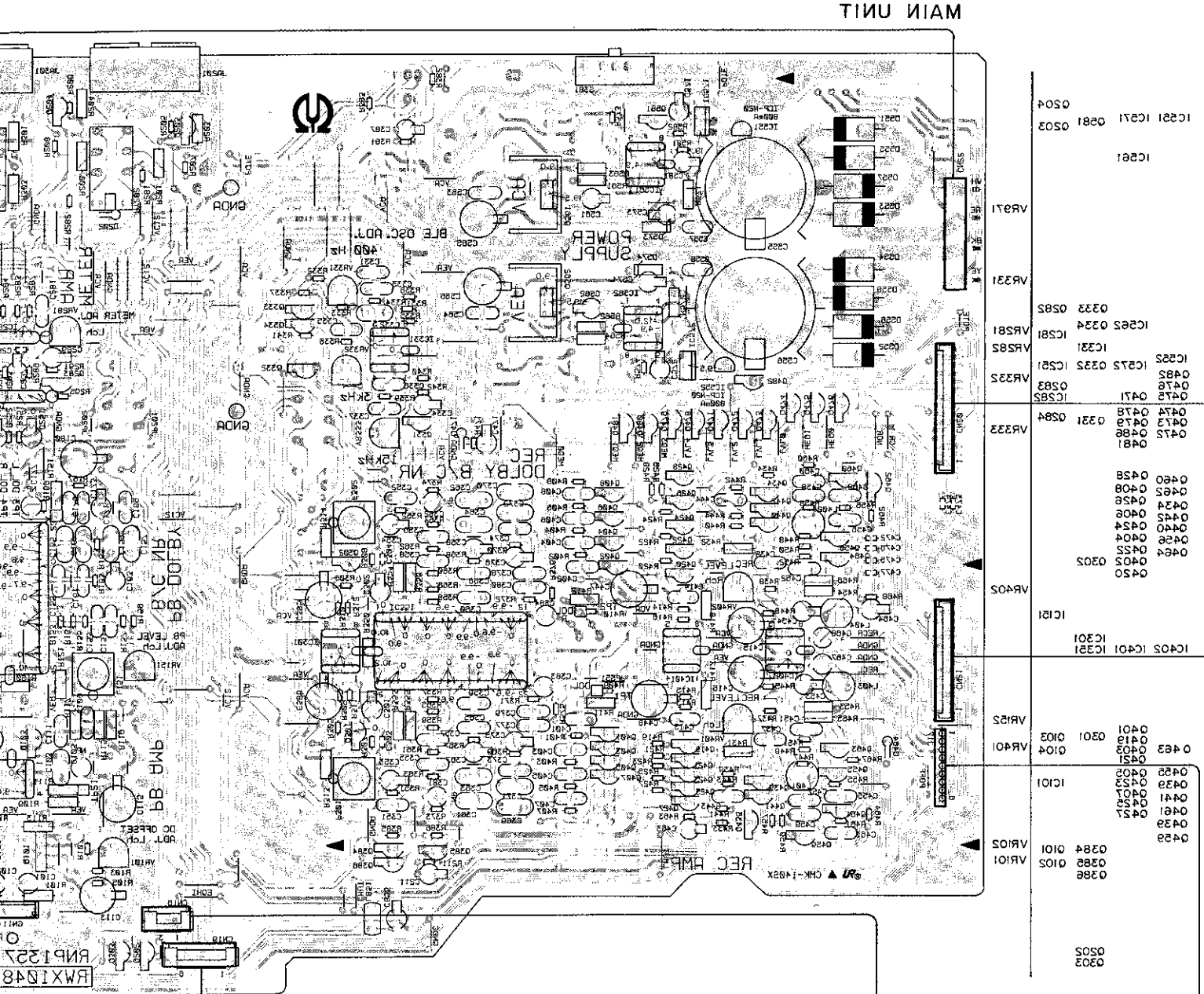

A

B

C

D

e

e

4

3

5

1

e

e

4

3

5

1

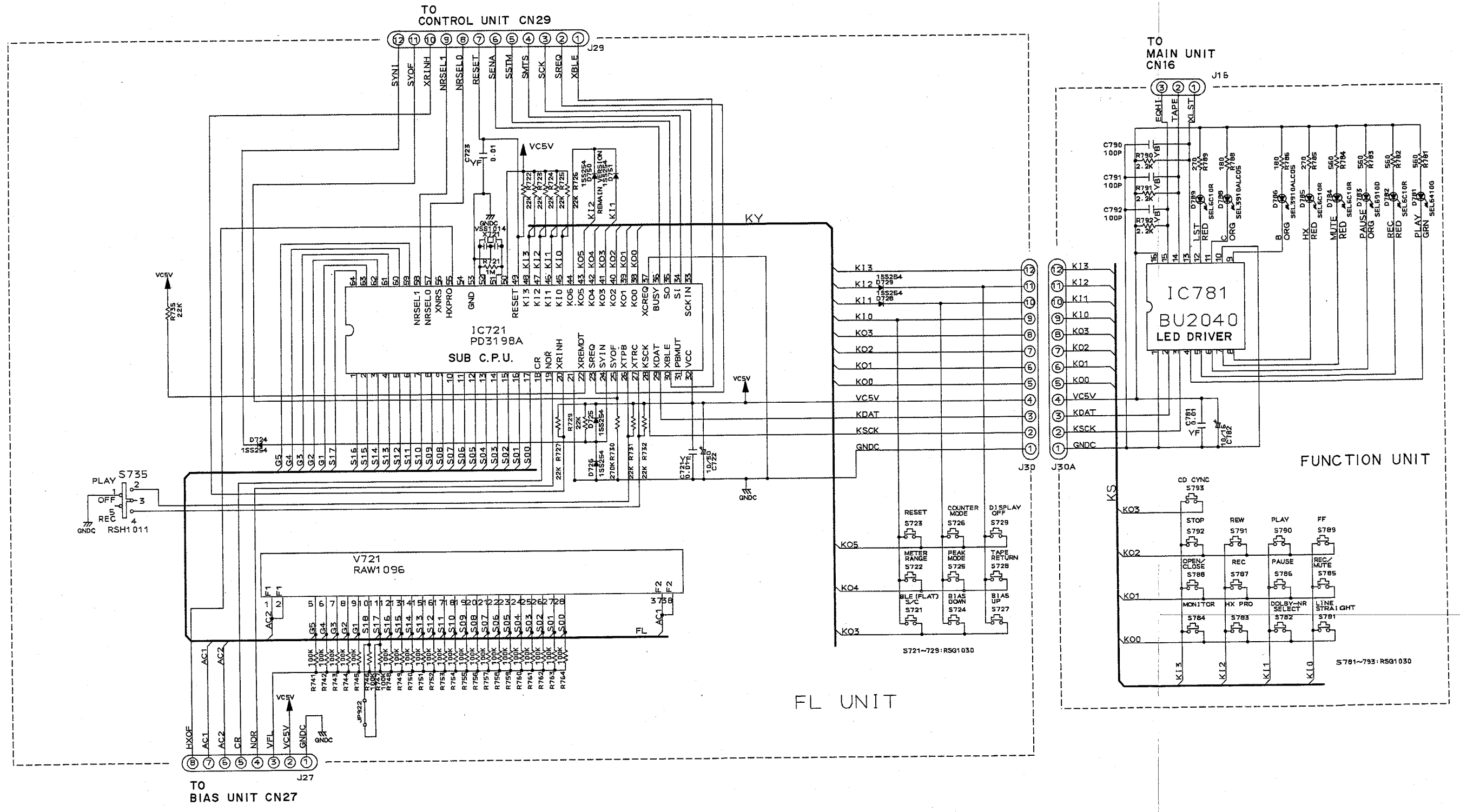

5. PCB PARTS LIST

NOTES:

- Parts without part number cannot be supplied.
- Parts marked by "⊙" are not always kept in stock. Their delivery time may be longer than usual or they may be unavailable.
- The Δ mark found on some component parts indicates the importance of the safety factor of the part. Therefore, when replacing, be sure to use parts of identical designation.
- When ordering resistors, first convert resistance values into code form as shown in the following examples.

Ex.1 When there are 2 effective digits (any digit apart from 0), such as 560 ohm and 47k ohm (tolerance is shown by J=5%, and K=10%)

560 Ω → 56 × 10¹ → 561 RD1/4PS 561J

47k Ω → 47 × 10³ → 473 RD1/4PS 473J

0.5 Ω → 0R5 RN2H 0R5K

1 Ω → 010 RS1P 010K

Ex.2 When there are 3 effective digits (such as in high precision metal film resistors).

5.62k Ω → 562 × 10¹ → 5621 RN1/4SR 5621F

Mark No.	Description	Part No.	Mark No.	Description	Part No.
----------	-------------	----------	----------	-------------	----------

LIST OF ASSEMBLIES

CONTROL UNIT
BALANCE VR UNIT
FL UNIT
FUNCTION UNIT
BIAS UNIT
HEADPHONE UNIT
MAIN UNIT

RELAY UNIT RWM1454
- REC SWITCH UNIT
- TAPE SELECTOR UNIT
- CONNECTOR UNIT
- SENSOR UNIT

CONTROL UNIT

SEMICONDUCTORS

IC651 MAIN CPU PD4359A
IC652 MGM80011AL
IC661 CMOS LOGIC IC TC4050BP
IC671 IC BA6109
IC681 IC BA6109

IC701 COMPARATOR BA10393N
IC703 COMPARATOR BA10393N
IC713 CMOS LOGIC IC TC4050BP
Q655, 656 DIGITAL TRANSISTOR DTA114TS
Q665 TRANSISTOR DTC114ES

Q667 TRANSISTOR DTC124ES
Q668 DIGITAL TRANSISTOR DTC114TS
Q672-674 TRANSISTOR DTC114ES
Q681-683 TRANSISTOR 2SA1309A
Q687 TRANSISTOR 2SA1309A

Q688 TRANSISTOR DTC114ES
Q705 DIGITAL TRANSISTOR DTA114ES
Q706 TRANSISTOR 2SC3311A
Q707, 708 DIGITAL TRANSISTOR DTC114TS
Q709 DIGITAL TRANSISTOR DTA114ES

Q710 DIGITAL TRANSISTOR DTC114TS
Q715 TRANSISTOR DTC114ES

D651-653 DIODE 1SS254
D665 DIODE 1SS254
Δ D681 RECRIFIER DIODE 1SR35-100A

COILS/TRANSFORMERS

L671 RTF1068

CAPACITORS

C651 CERAMIC CAPACITOR CKCYF103Z50
C652 ELECTR. CAPACITOR CEAS101M10
C653 ELECTR. CAPACITOR CEAS102M6R3
C657, 658 AXIAL CAPACITOR CKPUYB101K50
C661 CERAMIC CAPACITOR CKCYF103Z50

C662 ELECTR. CAPACITOR CEAS100M50
C666 ELECTR. CAPACITOR CEAS330M16
C671 CERAMIC CAPACITOR CKCYF103Z50
C672 CERAMIC CAPACITOR CKCYF473Z50
C681 ELECTR. CAPACITOR CEANP4R7M25

C682 ELECTR. CAPACITOR CEASR22M50
C683 CERAMIC CAPACITOR CKCYF103Z50
C684 ELECTR. CAPACITOR CEAS330M16
C685 ELECTR. CAPACITOR CEAS101M16
C691 ELECTR. CAPACITOR CEAS100M50

C701 CERAMIC CAPACITOR CKCYF473Z50
C702 ELECTR. CAPACITOR CEAS100M50
C703 CERAMIC CAPACITOR CKCYF473Z50
C713 ELECTR. CAPACITOR CEAS100M50
C714-716 CERAMIC CAPACITOR CKCYF103Z50

RESISTORS

R651-658 CARBONFILM RESISTOR RD1/6PM□□□J
R663 (10k) RCX□□□□
R665-668 CARBONFILM RESISTOR RD1/6PM□□□J
R671-675 CARBONFILM RESISTOR RD1/6PM□□□J
R681 METAL OXIDE RESISTOR RS1LMF□□□J

R683-688 CARBONFILM RESISTOR RD1/6PM□□□J
R691-704 CARBONFILM RESISTOR RD1/6PM□□□J
R705, 706 METALFILM RESISTOR RN1/6PQ□□□□F
R707 CARBONFILM RESISTOR RD1/6PM□□□J
R709-712 METALFILM RESISTOR RN1/6PQ□□□□F

Mark No.	Description	Part No.
R713 (10k)		RCX□□□□
R714, 715	CARBONFILM RESISTOR	RD1/6PM□□□J

OTHERS

CN200 TXC-P14X-A1
CN210 CONECTOR (12P) TXC-P12X-A1
JA71 JACK RKN1014
X651 CERAMIC RESONATOR VSS1014

BALANCE VR UNIT

RESISTORS

VR973 (200k) RCV1078

FUNCTION UNIT

SEMICONDUCTORS

IC781 LOGIC IC BU2040
D781 LED SEL6410G
D782 SEL6C10R
D783 LED SEL6910D
D784, 785 SEL6C10R

D786 LED SEL3910ALC05
D788 LED SEL3910ALC05
D789 SEL6C10R

SWITCHES

S781-793 SWITCH RSG1030

CAPACITORS

C781 CERAMIC CAPACITOR CKCYF103Z50
C782 ELECTR. CAPACITOR CEJA100M16
C790-792 AXIAL CAPACITOR CKPUYB101K50

RESISTORS

R781-786 CARBONFILM RESISTOR RD1/6PM□□□J
R788-792 CARBONFILM RESISTOR RD1/6PM□□□J

HEADPHONE UNIT

SEMICONDUCTORS

IC231 OP AMP M5238PF
Q231, 232 TRANSISTOR 2SD2144S

CAPACITORS

C231, 232 ELECTR. CAPACITOR CEYA010M50
C233, 234 ELECTR. CAPACITOR (100/25) PCH1076
C235, 236 AXIAL CAPACITOR CKPUYB221K50
C237, 238 ELECTR. CAPACITOR CEYA4R7M50

RESISTORS

R231-236 CARBONFILM RESISTOR RD1/6PM□□□J
R237, 238 CARBONFILM RESISTOR RDR1/4PM□□□J
R239-242 CARBONFILM RESISTOR RD1/6PM□□□J
VR231 VARIABLE RESISTOR (20k) PCS1002

OTHERS

JA231 JACK RKN1019

REC SWITCH UNIT

SWITCHES

S3 SWITCH RSG-143

Mark No.	Description	Part No.
----------	-------------	----------

TAPE SELECTOR UNIT

SWITCHES

S1, 2 RSH-070

CONNECTOR UNIT

CAPACITORS

C1 CERAMIC CAPACITOR CKCYF473Z50

RESISTORS

R4, 5 CARBONFILM RESISTOR RD1/6PM□□□J

SENSOR UNIT

SEMICONDUCTORS

D2 GPIA51HR

CAPACITORS

C3 CERAMIC CAPACITOR CKPUY103N16

RESISTORS

R3 CARBONFILM RESISTOR RD1/6PM□□□J

FL UNIT

SEMICONDUCTORS

IC721 PD3198A
D724-726 DIODE 1SS254
D728, 729 DIODE 1SS254
D750, 751 DIODE 1SS254

SWITCHES

S721-729 SWITCH RSG1030
S735 RSH1011

CAPACITORS

C721 CERAMIC CAPACITOR CKCYF103Z50
C722 ELECTR. CAPACITOR CEAS100M50
C723 CERAMIC CAPACITOR CKCYF103Z50

RESISTORS

R721-727 CARBONFILM RESISTOR RD1/6PM□□□J
R729-732 CARBONFILM RESISTOR RD1/6PM□□□J
R735 CARBONFILM RESISTOR RD1/6PM□□□J
R741-764 CARBONFILM RESISTOR RD1/6PM□□□J

OTHERS

V721 RAW1096
X721 CERAMIC RESONATOR VSS1014

BIAS UNIT

SEMICONDUCTORS

Δ IC521 DOLBY HX PRO IC UPC1297CA
Δ IC605, 606 REGULATOR IC NJM781 2FA
IC607 REGULATOR IC NJM780 5FA
Q504 TRANSISTOR 2SA128 3
Q505, 506 TRANSISTOR 2SD130 2

Q507 TRANSISTOR 2SC331 1A
Q508 TRANSISTOR DTC124ES
Q509 TRANSISTOR 2SC331 1A
Q510 TRANSISTOR DTC124ES
Q511 TRANSISTOR DTC114ES

Mark	No.	Description	Part No.
	Q512	DIGITAL TRANSISTOR	DTA114ES
	Q513	TRANSISTOR	2SA1309A
	Q535, 536	DIGITAL TRANSISTOR	DTC114TS
	Q543-546	TRANSISTOR	DTC114ES
	Q614	TRANSISTOR	2SA1309A
△	Q623	TRANSISTOR	2SA1283
	D501, 502	DIODE	1SS254
△	D601		S2VB20
△	D604	RECRIFIER DIODE	1SR35-100A
	D611-613	DIODE	1SS254
△	D621	RECRIFIER DIODE	1SR35-100A
	D622	ZENER DIODE	MTZJ6. 8B
△	D623	ZENER DIODE	MTZJ24D
SWITCHES			
△	S641	SWITCH	RSA-063
COILS/TRANSFORMERS			
	L501		RTF1160
	L502		RTD1067
	L521, 522		RTD1045
	L535, 536	RADIAL INDUCTOR	LFA122J
CAPACITORS			
	C501	CERAMIC CAPACITOR	CKCYF473Z50
	C502	ELECTR. CAPACITOR	CEAS101M16
	C503	ELECTR. CAPACITOR	CEAS100M50
	C504, 505	ELECTR. CAPACITOR	CEAS330M16
	C507, 508	AUDIO FILM CAPACITOR	CFTXA222J50
	C509	AUDIO FILM CAPACITOR	CFTXA153J50
	C510	AUDIO FILM CAPACITOR	CFTXA332J50
	C511	PORYPROPYLENE FILM C(1500PF)	RCE1026
	C515	ELECTR. CAPACITOR	CEAS220M25
	C516	ELECTR. CAPACITOR	CEAS100M50
	C517	ELECTR. CAPACITOR	CEAS4R7M50
	C521	CERAMIC CAPACITOR	CCCCH470J50
	C523, 524	CERAMIC CAPACITOR	CKCYF473Z50
	C525, 526	CERAMIC CAPACITOR	CCCSL221K500
	C527, 528	CERAMIC CAPACITOR (390P/500)	RCG1004
	C529, 530	AUDIO FILM CAPACITOR	CFTXA333J50
	C531, 532	AUDIO FILM CAPACITOR	CFTXA223J50
	C533, 534	AXIAL CAPACITOR	CKPUYB471K50
	C535, 536	AUDIO FILM CAPACITOR	CFTXA103J50
	C537	ELECTR. CAPACITOR	CEAS330M16
	C539, 540	CERAMIC CAPACITOR	CKCYF103Z50
	C601-603	CERAMIC CAPACITOR	CKCYF473Z50
	C605	ELECTR. CAPACITOR(6800 μ F/25)	RCH1032
	C606	ELECTR. CAPACITOR	CEAS101M16
	C607	ELECTR. CAPACITOR	CEAS682M16
	C608	ELECTR. CAPACITOR	CEAS102M6R3
	C611	ELECTR. CAPACITOR	CEAS4R7M50
	C614	CERAMIC CAPACITOR	CKCYF103Z50
	C621	CERAMIC CAPACITOR	CKCYF473Z50
	C622	ELECTR. CAPACITOR	CEAS101M50
	C623	CERAMIC CAPACITOR	CKCYF473Z50
	C624	ELECTR. CAPACITOR	CEAS101M25

Mark	No.	Description	Part No.
	C625	CERAMIC CAPACITOR	CKCYF473Z50
	C626	ELECTR. CAPACITOR	CEAS101M16
	C627, 628	CERAMIC CAPACITOR	CKCYF473Z50
△	C641	CAPACITOR(0. 01 μ F/AC400)	VCG-044
RESISTORS			
	R503	CARBONFILM RESISTOR	RD1/2LF□□□J
	R505-508	CARBONFILM RESISTOR	RD1/6PM□□□J
	R509, 510	CARBONFILM RESISTOR	RD1/2PMF□□□J
	R511	CARBONFILM RESISTOR	RD1/2LF□□□J
	R512-514	CARBONFILM RESISTOR	RD1/6PM□□□J
	R515, 516	METALFILM RESISTOR	RN1/6PQ□□□□F
	R517-519	CARBONFILM RESISTOR	RD1/6PM□□□J
	R523-525	CARBONFILM RESISTOR	RD1/6PM□□□J
	R531	CARBONFILM RESISTOR	RD1/6PM□□□J
	R533-536	CARBONFILM RESISTOR	RD1/6PM□□□J
	R539-542	CARBONFILM RESISTOR	RD1/6PM□□□J
	R611-613	CARBONFILM RESISTOR	RD1/6PM□□□J
△	R621	FUSIBLE RESISTOR	RFA1/4L□□□J
	R622	CARBONFILM RESISTOR	RD1/2PMF□□□J
	R623	METAL OXIDE RESISTOR	RS1LMF□□□J
	VR535, 536, 541-544VR(3. 3k)		RCP1089
	VR545, 546	VR(15k)	RCP1090

MAIN UNIT

SEMICONDUCTORS

	IC101	OP-AMP-IC	M5220P
	IC151	DOLBY-B, C IC	CX20188
	IC251	IC	BA335
	IC281	IC	BA15218N
	IC282		BA6138
	IC301	OP-AMP, IC	M5218AP
	IC331	OP-AMP IC	BA15218
	IC351	DOLBY-B, C IC	CX20188
	IC401, 402	OP AMP	M5238PF
△	IC551, 552	IC PROTECTOR	ICP-N20
	IC561, 562	OP-AMP IC	NJM2114D
△	IC571	REGULATOR IC	NJM78M12FA
△	IC572	REGULATOR IC	NJM79M12FA
	Q101, 102	N-DUAL-FET	2SK389
	Q103, 104	DIGITAL TRANSISTOR	DTC114TS
	Q202	DIGITAL TRANSISTOR	DTC114TS
	Q203, 204	TRANSISTOR	2SD2144S
	Q282	TRANSISTOR	DTC114ES
	Q283, 284	TRANSISTOR	DTC124ES
	Q301, 302	TRANSISTOR	2SD2144S
	Q303	DIGITAL TRANSISTOR	DTC114TS
	Q331-334	TRANSISTOR	DTC114ES
	Q384	DIGITAL TRANSISTOR	DTA114ES
	Q385, 386	TRANSISTOR	DTC114ES
	Q401-408	DIGITAL TRANSISTOR	DTC114TS
	Q419-428	DIGITAL TRANSISTOR	DTC114TS
	Q433, 434	TRANSISTOR	2SD2144S
	Q439-442	DIGITAL TRANSISTOR	DTC114TS
	Q455, 456	DIGITAL TRANSISTOR	DTC114TS

Mark	No.	Description	Part No.	Mark	No.	Description	Part No.
	Q459-462	DIGITAL TRANSISTOR	DTC114TS		C281, 282	AUDIO FILM CAPACITOR	CFTXA563J50
	Q463, 464	TRANSISTOR	2SD2144S		C283, 284	AXIAL CERAMIC C.	CCPUSL470J50
	Q471-476	DIGITAL TRANSISTOR	DTA114ES		C287-290	ELECTR. CAPACITOR	CEAS4R7M50
	Q478-482	DIGITAL TRANSISTOR	DTA114ES		C300	CERAMIC CAPACITOR	CKCYF473Z50
△	Q561	TRANSISTOR	2SD1855		C301, 302	ELECTR. CAPACITOR	CEYA010M50
△	Q562	TRANSISTOR	2SB1335		C303, 304	AXIAL CAPACITOR	CKPUYB221K50
	Q581	TRANSISTOR	2SA1309A		C331	AUDIO FILM CAPACITOR	CFTXA683J50
	D202	DIODE	1SS254		C332	MYLAR FILM CAPACITOR	CQMA104J50
	D301	DIODE	1SS254		C333	MYLAR FILM CAPACITOR	CQMA123J50
	D464	DIODE	1SS254		C334	ELECTR. CAPACITOR	CEAS010M50
	D471	ZENER DIODE	MTZJ4. 7A		C335	AUDIO FILM CAPACITOR	CFTXA682J50
△	D551-558		31DF2-FC5		C336	MYLAR FILM CAPACITOR	CQMA123J50
△	D573, 574	ZENER DIODE	HZ5BLL		C337	MYLAR FILM CAPACITOR	CQMA182J50
					C353, 354	ELECTR. CAPACITOR	CEYA100M50
	SWITCHES				C355-358	AUDIO FILM CAPACITOR	CFTXA222J50
	S381		RSH1025		C359, 360	AUDIO FILM CAPACITOR	CFTXA392J50
	RELAYS				C361, 362	AUDIO FILM CAPACITOR	CFTXA474J50
	RY202		RSR1016		C363, 364	AUDIO FILM CAPACITOR	CFTXA154J50
	RY301		RSR1016		C365, 366	AUDIO FILM CAPACITOR	CFTXA153J50
	COILS/TRANSFORMERS				C367, 368	ELECTR. CAPACITOR	CEYA010M50
	L151, 152	BIAS TRAP(210KHZ)	RTF1175		C369, 370	AUDIO FILM CAPACITOR	CFTXA224J50
	L401, 402	COIL	RTF1022		C371, 372	AUDIO FILM CAPACITOR	CFTXA683J50
	L403, 404		RTF1013		C373, 374	AUDIO FILM CAPACITOR	CFTXA563J50
	L851	RADIAL INDUCTOR	LFA121K		C375, 376	ELECTR. CAPACITOR	CEYA010M50
	F301, 302	FILTER	RTF1059		C377, 378		CFTXA562J50
	CAPACITORS				C379, 380	AUDIO FILM CAPACITOR	CFTXA103J50
	C101, 102	PL. STYRENE CAPACITOR	CQSF151J50		C381-384	ELECTR. CAPACITOR	RCH1037
	C103, 104	AUDIO FILM CAPACITOR	CFTXA563J50		(10/25)		
	C105, 106	ELECTR. CAPACITOR	RCH1037		C385, 386	ELECTR. CAPACITOR(100/25)	PCH1076
	(10 μF/25)				C387	ELECTR. CAPACITOR	CEAS330M16
	C109, 110	AUDIO FILM CAPACITOR	CFTXA472J50		C401, 402	AUDIO FILM CAPACITOR	CFTXA103J50
	C111, 112	AUDIO FILM CAPACITOR	CFTXA273J50		C403, 404	AUDIO FILM CAPACITOR	CFTXA472J50
	C113-116	ELECTR. CAPACITOR(100/25)	PCH1076		C405, 406		CFTXA272J50
	C151-154	AUDIO FILM CAPACITOR	CFTXA222J50		C407, 408	AUDIO FILM CAPACITOR	CFTXA122J50
	C155, 156	AUDIO FILM CAPACITOR	CFTXA392J50		C413, 414	AUDIO FILM CAPACITOR	CFTXA103J50
	C157, 158	AUDIO FILM CAPACITOR	CFTXA474J50		C415, 416	ELECTR. CAPACITOR(100/25)	PCH1076
	C159, 160	AUDIO FILM CAPACITOR	CFTXA154J50		C437, 438		CFTXA102J50
	C161, 162	AUDIO FILM CAPACITOR	CFTXA153J50		C443, 444	AUDIO FILM CAPACITOR	CFTXA472J50
	C163, 164	ELECTR. CAPACITOR	CEYA010M50		C447, 448	ELECTR. CAPACITOR(220/25)	PCH1077
	C165, 166	AUDIO FILM CAPACITOR	CFTXA224J50		C451, 452	AUDIO FILM CAPACITOR	CFTXA274J50
	C167, 168	AUDIO FILM CAPACITOR	CFTXA683J50		C453, 454	ELECTR. CAPACITOR	CEYA330M25
	C169, 170	AUDIO FILM CAPACITOR	CFTXA563J50		C455, 456	AUDIO FILM CAPACITOR	CFTXA103J50
	C171, 172	ELECTR. CAPACITOR	CEYA010M50		C457, 458		CFTXA562J50
	C173, 174		CFTXA562J50		C459, 460	AUDIO FILM CAPACITOR	CFTXA472J50
	C175, 176	AUDIO FILM CAPACITOR	CFTXA103J50		C461, 462	AUDIO FILM CAPACITOR	CFTXA222J50
	C177, 178	ELECTR. CAPACITOR	RCH1037		C463	ELECTR. CAPACITOR	CEAS010M50
	(10 μF/25)				C464	ELECTR. CAPACITOR	CEAS100M50
	C179, 180	ELECTR. CAPACITOR(100/25)	PCH1076		C467, 468	PL. STYRENE CAPACITOR	CQSA561J50
	C211	ELECTR. CAPACITOR	CEAS010M50		C471	ELECTR. CAPACITOR	CEAS100M50
	C251, 252	ELECTR. CAPACITOR	CEASR10M50		C472-476	CERAMIC CAPACITOR	CKPUYY103N16
	C253	AUDIO FILM CAPACITOR	CFTXA473J50		C555	ELECTR. CAPACITOR(3300 μF)	RCH1048
	C254, 255	ELECTR. CAPACITOR	CEASR10M50		C556	ELECTR. CAPACITOR(3300 μF)	RCH1049
	C256	ELECTR. CAPACITOR	CEASR47M50		C557, 558	AUDIO FILM CAPACITOR	CFTXA563J50
	C257	AUDIO FILM CAPACITOR	CFTXA473J50		C561, 562	ELECTR. CAPACITOR	CEYA100M50
					C563, 564	AUDIO FILM CAPACITOR	CFTXA563J50

Mark	No.	Description	Part No.	Mark	No.	Description	Part No.
	C565, 566	ELECTR. CAPACITOR (100 μ F/25)	PCH1084		VR401, 402	VARIABLE RESISTOR(20k)	RCP1017
	C571, 572	ELECTR. CAPACITOR	CEYA010M50		VR971	VARIABLE RESISTOR(20k)	RCV1019
	C573, 574	ELECTR. CAPACITOR	CEYA330M25		OTHERS		
	C581	ELECTR. CAPACITOR	CEAS220M50		SCREW		IBZ30P100FCC
	C855	ELECTR. CAPACITOR	CEAS101M10		CN20		TXC-P14P-A1
RESISTORS					CN21		TXC-P12P-A1
	R101, 102	CARBONFILM RESISTOR	RDR1/4PM□□□J		JA201	JACK	RKB1020
	R103-108	CARBONFILM RESISTOR	RD1/6PM□□□J		JA301	JACK	RKB1020
	R109-122	CARBONFILM RESISTOR	RDR1/4PM□□□J				
	R150-152	CARBONFILM RESISTOR	RDR1/4PM□□□J				
	R153-170	CARBONFILM RESISTOR	RD1/6PM□□□J				
	R201-204	CARBONFILM RESISTOR	RDR1/4PM□□□J				
	R205-208	CARBONFILM RESISTOR	RD1/6PM□□□J				
	R211	CARBONFILM RESISTOR	RD1/6PM□□□J				
	R251-255	CARBONFILM RESISTOR	RD1/6PM□□□J				
	R281-284	CARBONFILM RESISTOR	RD1/6PM□□□J				
	R286-296	CARBONFILM RESISTOR	RD1/6PM□□□J				
	R301-304	CARBONFILM RESISTOR	RDR1/4PM□□□J				
	R305-312	CARBONFILM RESISTOR	RD1/6PM□□□J				
	R313, 314	CARBONFILM RESISTOR	RDR1/4PM□□□J				
	R331-342	CARBONFILM RESISTOR	RD1/6PM□□□J				
	R350	CARBONFILM RESISTOR	RDR1/4PM□□□J				
	R351, 352	CARBONFILM RESISTOR	RD1/6PM□□□J				
	R353-356	CARBONFILM RESISTOR	RDR1/4PM□□□J				
	R357-376	CARBONFILM RESISTOR	RD1/6PM□□□J				
	R381-383	CARBONFILM RESISTOR	RD1/6PM□□□J				
	R385, 386	CARBONFILM RESISTOR	RD1/6PM□□□J				
	R401-408	CARBONFILM RESISTOR	RD1/6PM□□□J				
	R409, 410	(100k)	RCN□□□□				
	R411, 412	CARBONFILM RESISTOR	RDR1/4PM□□□J				
	R413-416	CARBONFILM RESISTOR	RD1/6PM□□□J				
	R417, 418	CARBONFILM RESISTOR	RDR1/4PM□□□J				
	R419-428	CARBONFILM RESISTOR	RD1/6PM□□□J				
	R431, 432	CARBONFILM RESISTOR	RDR1/4PM□□□J				
	R433, 434	CARBONFILM RESISTOR	RD1/6PM□□□J				
	R437-452	CARBONFILM RESISTOR	RD1/6PM□□□J				
	R453, 454	CARBONFILM RESISTOR	RDR1/4PM□□□J				
	R455-464	CARBONFILM RESISTOR	RD1/6PM□□□J				
	R465, 466	CARBONFILM RESISTOR	RDR1/4PM□□□J				
	R467, 468	CARBONFILM RESISTOR	RD1/6PM□□□J				
	R471	CARBONFILM RESISTOR	RD1/6PM□□□J				
	R561-564	CARBONFILM RESISTOR	RDR1/4PM□□□J				
	R571, 572	CARBONFILM RESISTOR	RDR1/4PM□□□J				
	R573, 574	CARBONFILM RESISTOR	RD1/6PM□□□J				
	R581, 582	CARBONFILM RESISTOR	RD1/6PM□□□J				
	R851	CARBONFILM RESISTOR	RD1/6PM□□□J				
	VR101, 102	VR(4.7k)	RCP1053				
	VR151, 152	VARIABLE RESISTOR(5k)	RCP1088				
	VR281, 282	VR(22k)	RCP1046				
	VR331, 332	VR(10k)	RCP1045				
	VR333	VR(47k)	RCP1047				

6. ADJUSTMENTS

6.1 MECHANISM RELATED ADJUSTMENT

1. Tape running and azimuth adjustment				2. Tape Speed Adjustment		
No.	Mode	Adjustment Location	Specifications	Mode	Adjustment Location	Specifications
1	-	-	Insert half mirror in side A (set screws at front).	PLAY	Capstan motor adjustment hole (Refer to Fig. 3.)	Adjust so that the playback frequency is 3015 ± 5 Hz at the beginning of winding of test tape STD-301.
2	PLAY	Height adjustment unit (Refer to Fig. 1)	Playback the above tape and adjust so that there is no curling of the tape in the guide section of the head. (Refer to Fig. 2.)	PLAY	-	Playback test tape STD-301 again and confirm that the above specifications are satisfied.
3	PLAY	Azimuth adjustment screw (Refer to Fig. 1.)	Playback test tape STD-331E and adjust so that the 10 kHz output level is maximum and also so that there is no phase difference between L-ch and R-ch.			
4	Check Item 2 above again and adjust again if it does not satisfy the specifications. (Be sure to adjust Item 3 when Item 2 is adjusted.)					

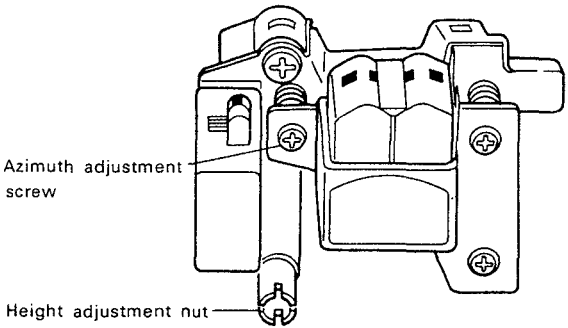

Azimuth adjustment screw

Height adjustment nut

Fig. 1

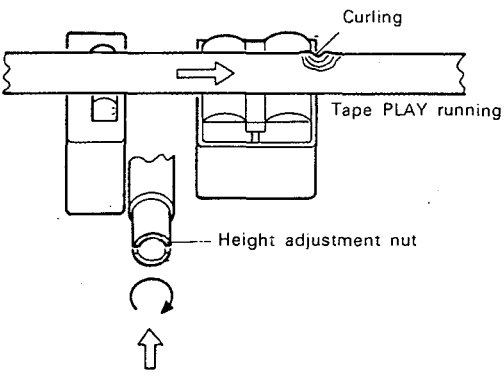

Curling

Tape PLAY running

Height adjustment nut

Fig. 2

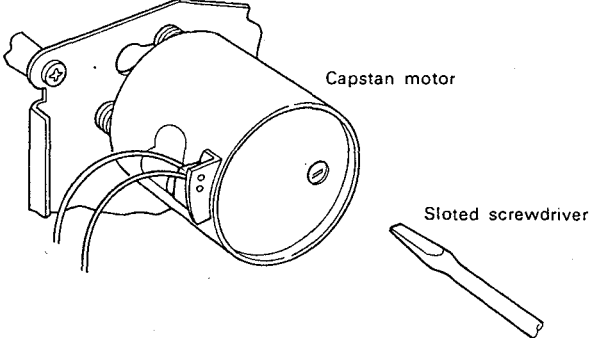

Capstan motor

Slotted screwdriver

Fig. 3

6.2 ELECTRICAL ADJUSTMENTS

Adjustment Conditions

1. The mechanical adjustments must be completed first.
2. The head must be cleaned and demagnetized.
3. Turn power on allow the deck to warm up for at least a few minutes before commencing any electrical adjustments.
4. The reference signal is 0 dBV=1 Vrms.
5. Connect a 50 kΩ (or between 47k to 52 kΩ) load resistance to the OUTPUT terminals.
6. Unless otherwise specified, the switches listed below are left in the positions indicated.

DOLBY NR : OFF
 TAPE SELECTOR : NORM

Test Tapes

- STD-331E : Playback adjustments
 (See Fig. 6-1)
- STD-631 : NORMAL blank tape
 STD-621 : CrO₂ blank tape
 STD-610 : METAL blank tape

* As the reference recording level is 250 nwb/m for STD-331E, the recording level will be higher by 4 dB for STD-331B (160 nwb/m). When adjusting, pay carefull attention to the type of tape used.

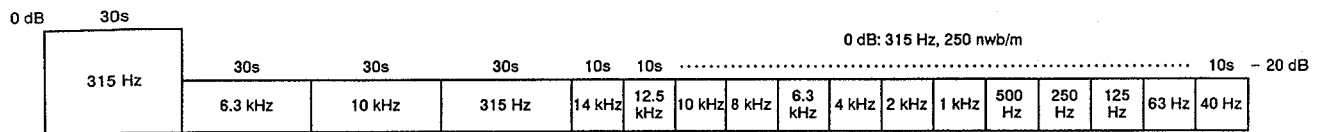

Fig. 6-1 Constants of the test tape STD-331E

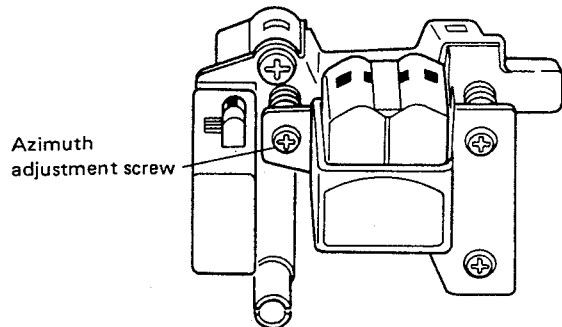

Fig. 6-2 Head azimuth adjustment

List of Adjustments

Playback sections

1. Head azimuth adjustment.
2. Playback level adjustment.
3. DC balance adjustment.

Recording sections

1. Bias oscillator adjustment.
2. Bias trap adjustment.
3. Recording bias adjustment.
4. Recording level adjustment.
5. Level meter check.
6. AUTO BLE adjustment.

Dolby noise reduction and HX Pro headroom extension manufactured under license from Dolby Laboratories Licensing Corporation. HX Pro originated by Bang & Olufsen. "DOLBY", the double-D symbol and "HX PRO" are trademarks of Dolby Laboratories Licensing Corporation.

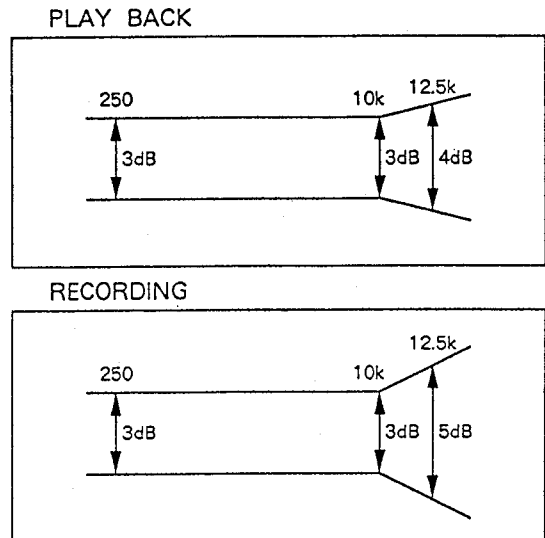

Fig. 6-3 Frequency response zone

PLAYBACK SECTION

1. Head Azimuth Adjustment

- Turn VR105, 106 to mechanical center positions.

No.	Mode	Input signal & test tape	Adjustment location	Measuring location	Adjustment value	Remarks
1.	PLAY	Play the 10 kHz/-20 dB section of STD-331E test tape.	Head azimuth adjustment screw. (See Fig. 6-2)	LINE OUT	Maximum playback signal level.	
2.	STOP	Lock the screw with screw lock after completing adjustment.				

2. Playback Level Adjustment

No.	Mode	Input signal & test tape	Adjustment location	Measuring location	Adjustment value	Remarks
1.	PLAY	Play the 315 Hz/0 dB section of the STD-331E test tape.	Deck VR151 (Lch) VR152 (Rch)	TP. 3 (Lch) TP. 4 (Rch)	-11.0 dBV	This adjustment must be performed accurately for proper Dolby level setting.

3. DC Balance Adjustment

No.	Mode	Input signal & test tape	Adjustment location	Measuring location	Adjustment value	Remarks
1.			VR101 (Lch) VR102 (Rch)	TP. 21 (Lch) TP. 22 (Rch)	0V ± 0.2V	

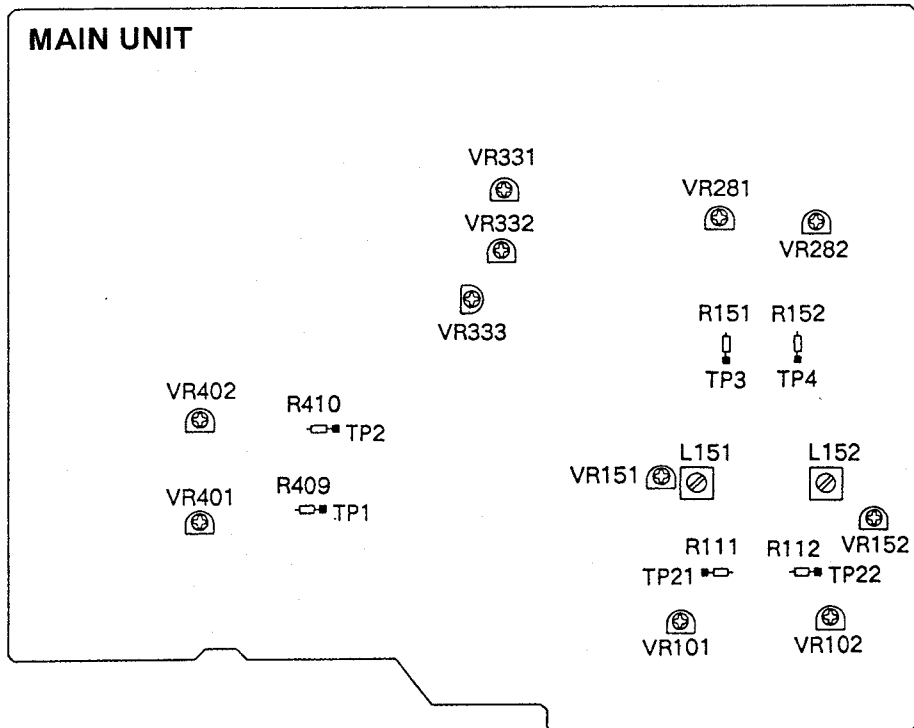

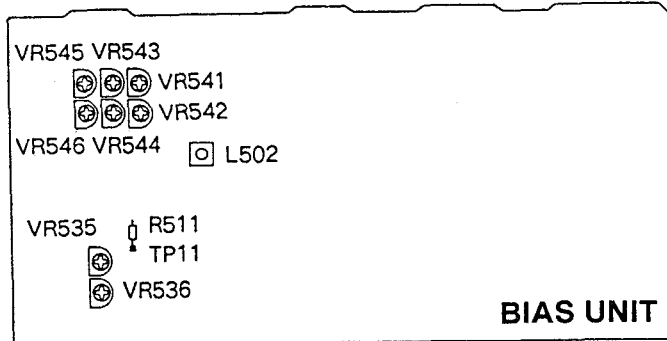

Fig. 6-4 Adjusting points

RECORDING SECTION

1. Bias Oscillator Adjustment

No.	Mode	Input signal & test tape	Adjustment location		Measuring location	Adjustment value	Remarks
1.	REC/ PLAY	Load the STD-610 test tape with no input signal.	Deck	L502	TP. 11	210kHz ± 600 Hz	

2. Bias Trap Adjustment

No.	Mode	Input signal & test tape	Adjustment location		Measuring location	Adjustment value	Remarks
1.	REC/ PLAY	Load the STD-610 test tape with no input signal.	Deck	L151 (Lch) L152 (Rch)	TP. 3 (Lch) TP. 4 (Rch)	Minimum output	

3. Recording Bias Adjustment

- Turn ON the DOLBY HX PRO switch on the front panel, and set the BIAS control to the center position.

No.	Mode	Input signal & test tape	Adjustment location		Measuring location	Adjustment value	Remarks
1.	REC/ PAUSE	Apply a 315 Hz/-26 dBV (-20VU meter reading) signal to the line input terminals and insert STD-631.	—			—	
2.	REC → PLAY	Record and play back the 315 Hz signal and a 10 kHz signal at -26 dBV input level.	NOR	VR541 (L ch) VR542 (R ch)	LINE OUT	Record and play back repeatedly, comparing the 315 Hz and 10 kHz playback levels, and adjust to 0 ± 0.5 dB.	
3.		Record the 10 kHz/315 Hz, -26 dBV signal on STD-621 and play back.	CrO2	VR543 (L ch) VR544 (R ch)		0 dBV ± 0.5 dB	
4.		Record the 10 kHz/315 Hz, -26 dBV signal on STD-610 and play back.	METAL	VR545 (L ch) VR546 (R ch)		0 dBV ± 0.5 dB	
5.	Check distortion value after adjustment is completed and confirm that there is no underbias.						
6.	Turn OFF the DOLBY HX PRO switch.						
7.	REC → PLAY	Record and play back the 315 Hz signal and a 10kHz signal at -26 dBV input level.	NOR	VR535 (L ch) VR536 (R ch)	LINE OUT	Turn the control fully counterclockwise, and gradually turn to the right to adjust to 0 dB ± 0.5 dB compared when HX-Pro is ON.	Turn control clockwise past the peak to assure proper overbias value.

Adjust in the order of NOR → CrO2 → METAL. After completing all adjustments, note that the adjustment values for CrO2 and METAL will be altered if NOR is re-adjusted, and that for METAL will be altered if CrO2 is re-adjusted.

4. Recording Level Adjustment

- Turn OFF the DOLBY NR switch.

No.	Mode	Input signal & test tape	Adjustment location		Measuring location	Adjustment value	Remarks
1.	REC/ PAUSE	Apply the 315 Hz/-6 dBV signal to the line input, and load STD-631 (NORM).	REC level control volume		TP. 1 (Lch) TP. 2 (Rch)	-11.2 dBV	
2.	REC → PLAY	Record and play back the 315 Hz/-6 dBV signal.	Deck	VR401 (Lch) VR402 (Rch)	TP. 3 (Lch) TP. 4 (Rch)	Repeatedly record, playback and adjust so that the playback signal level becomes -11.2 dBV.	Recording bias adjustment and recording level adjustment with STD-631 must be performed accurately as reference for BLE adjustment.
3.	REC → PLAY	Record the 315 Hz/-6 dBV signal on STD-621 (CrO2), and play it back.	Check			-11.2 dBV ± 1 dB	
4.	REC → PLAY	Record the 315 Hz/-6 dBV signal on STD-610 (METAL), and play it back.	Check			-11.2 dBV ± 1 dB	

5. Level Meter Adjustment

No.	Mode	Input signal & test tape	Adjustment location		Measuring location	Adjustment value	Remarks
1.	REC/ PAUSE	Apply a 315 Hz/-6 dBV (316 mV) signal to the line input terminals.	VR281 (Lch) VR282 (Rch)		TP. 1 (Lch) TP. 2 (Rch)	Always set the enlarged mode when adjusting. Adjust so that the 0 dB segment lights at a level of -11.2 ± 0.5 dBV (-11.2 ± 1.0 dBV in the normal mode).	Adjust by turning clockwise until the lamp lights up.

6. AUTO BLE Adjustment

- BLE Adjustment must be performed after all other adjustments are completed.
- This adjustment should be performed in the test mode.
- Entering the test mode

Press the MODE (COUNTER), RANGE and MONITOR keys on the front panel simultaneously, with the power ON. The unit enters the test mode and oscillates a 400 Hz signal.

Thereafter, each time the START/CLEAR key is pressed, the oscillation frequency changes as follows: 3 kHz oscillation → 15 kHz oscillation → Release

No.	Mode	Input signal & test tape	Adjustment location		Measuring location	Adjustment value	Remarks
1.		REC LEVEL VR MIN or no signal input.	-		-	-	
2.		Press the three keys MODE (COUNTER), RANGE and MONITOR on the front panel simultaneously.	VR331		Level meter Rch	Adjust so that 0 dB on the level meter lights.	400 Hz adjustment
3.		Press the START/CLEAR key once.	VR332			Adjust so that 0 dB on the level meter lights.	3 kHz adjustment
4.		Press the START/CLEAR key once.	VR333			Adjust so that -3 dB on the level meter lights.	15 kHz adjustment
5.	When the START/CLEAR key is pressed again, the test mode is released.						

6. REGLAGES

6.1 REGLAGES RELATIFS AU MECANISME

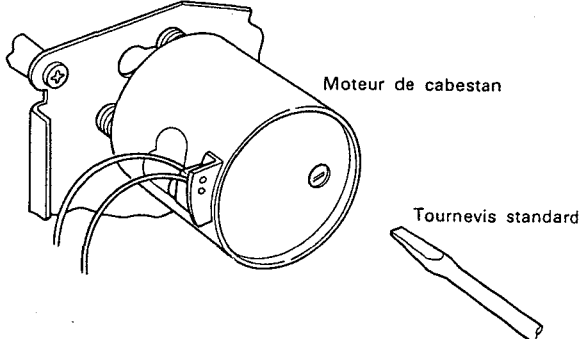
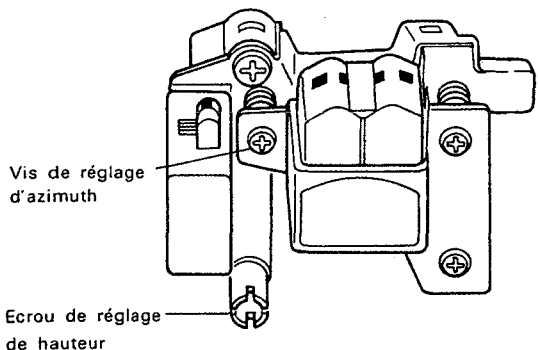
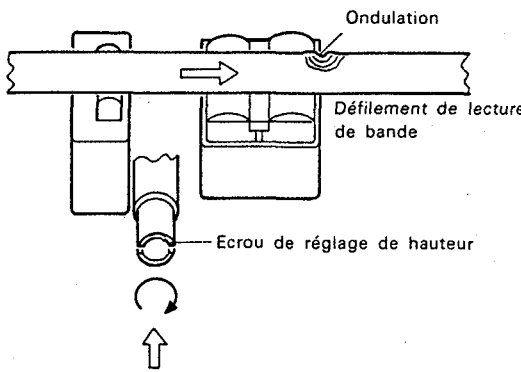
1. Réglage d'azimuth et de défilement de bande				2. Réglage de vitesse de bande		
N.º	Mode	Emplacement de réglage	Spécifications	Mode	Point de réglage	Caractéristiques
1	-	-	Insérer le demi-miroir dans le côté A (régler les vis à l'avant).	LECTURE	Orifice de réglage du moteur de cabestan (Se reporter à la Fig. 3)	Régler afin que la fréquence de lecture soit de 3015 ± 5 Hz au début de l'enroulement de la bande d'essai STD-301.
2	PLAY	Ecrou de réglage de hauteur (Se reporter à la Fig. 1.)	Reproduire la bande ci-dessus et régler pour qu'il n'y ait pas d'ondulation de la bande dans la section guide de la tête. (Se reporter à la Fig. 2.)	LECTURE	-	Reproduire à nouveau la bande d'essai STD-301 et confirmer que les caractéristiques ci-dessus sont satisfaisantes.
3	PLAY	Vis de réglage d'azimuth (Se reporter à la Fig. 1.)	Reproduire la bande d'essai STD-331E et régler pour que le niveau de sortie de 10 kHz soit maximum et également pour qu'il n'y ait pas de déphasage entre le canal gauche et le canal droit.	 <p>Fig. 3</p>		
4	Vérifier à nouveau l'article 2 ci-dessus et régler s'il ne satisfait pas les spécifications. (Toujours régler l'article 3 lorsque l'article 2 est réglé.)					
 <p>Fig. 1</p>						
 <p>Fig. 2</p>						

6.2 REGLAGES ELECTRIQUES

Conditions de réglage

1. Les réglages mécaniques doivent tout d'abord être terminés.
2. Les têtes doivent être nettoyées et démagnétisées.
3. Mettre la platine sous tension et la laisser chauffer pendant au moins quelques minutes avant de commencer les réglages électriques.
4. Le signal de référence est de 0 dBV=1 Vrms.
5. Connecter une résistance de charge de 50 kΩ (tolérance 47k à 52 kΩ) aux bornes de sortie (OUTPUT).
6. Sauf indication contraire, les commutateurs ci-dessous doivent être laissés sur les positions indiquées.
 DOLBY NR : OFF
 Sélecteur de bande : NORM
 (TAPE SELECTOR)

Bandes d'essai

- STD-331E : Réglages de la lecture
 (Voir fig. 6-1)
- STD-631 : Bande vierge de type normal
- STD-621 : Bande vierge de type chrome
- STD-610 : Bande vierge de type métal

Liste des réglages

Sections de lecture

1. Réglage de l'azimut de la tête.
2. Réglage du niveau de lecture.
3. Réglage de l'équilibre CC.

Sections d'enregistrement

1. Réglage de l'oscillateur de polarisation.
2. Réglage du circuit réjecteur de polarisation
3. Réglage de la polarisation d'enregistrement.
4. Réglage du niveau d'enregistrement.
5. Réglage de l'indicateur de niveau.
6. Réglage de AUTO BLE

* Le niveau d'enregistrement de référence étant de 250 nwb/m pour le STD-331E, le niveau d'enregistrement sera supérieur de 4 dB pour le STD-331B (160 nwb/m). Pour le réglage, tenir compte du type de bande utilisé.

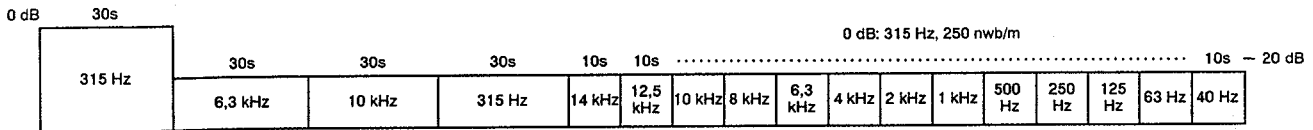

Fig. 6-1 Constantes de la bande d'essai STD-331E

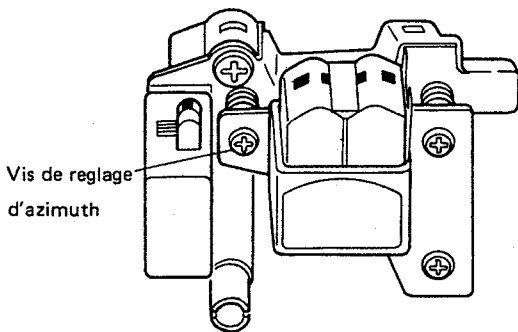

Fig. 6-2 Réglage de l'azimut de la tête

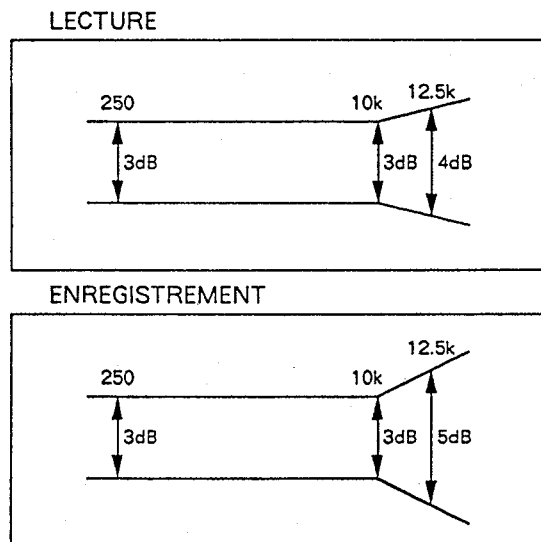

Fig. 6-3 Zone de réponse en fréquence

SECTION DE LECTURE

1. Réglage de l'azimut de la tête

- Tourner VR105, 106 sur leur position centrale mécanique.

No.	Mode	Signal d'entrée et bande d'essai	Points de réglage	Points de mesure	Valeur de réglage	Remarques
1.	PLAY	Reproduire la section 10 kHz/-20 dB de la bande d'essai STD-331E.	Vis de réglage de l'azimut de la tête. (Voir fig. 6-2)	LINE OUT	Niveau du signal de reproduction maximum.	
2.	STOP	Verrouiller la vis avec le verrouillage de vis après avoir terminé le réglage.				

2. Réglage du niveau de lecture

No.	Mode	Signal d'entrée et bande d'essai	Points de réglage	Points de mesure	Valeur de réglage	Remarques
1.	PLAY	Reproduire la section 315 Hz/0 dB de la bande d'essai STD-331E.	Platine VR151 (can. G) VR152 (can. D)	TP. 3 (can. G) TP. 4 (can. D)	-11,0 dBV	Ce réglage doit être effectué avec précision pour un réglage adéquat du niveau Dolby.

3. Réglage de l'équilibre CC

No.	Mode	Signal d'entrée et bande d'essai	Points de réglage	Points de mesure	Valeur de réglage	Remarques
1.			VR101 (can. G) VR102 (can. D)	TP. 21 (can. G) TP. 22 (can. D)	0V ± 0,2V	

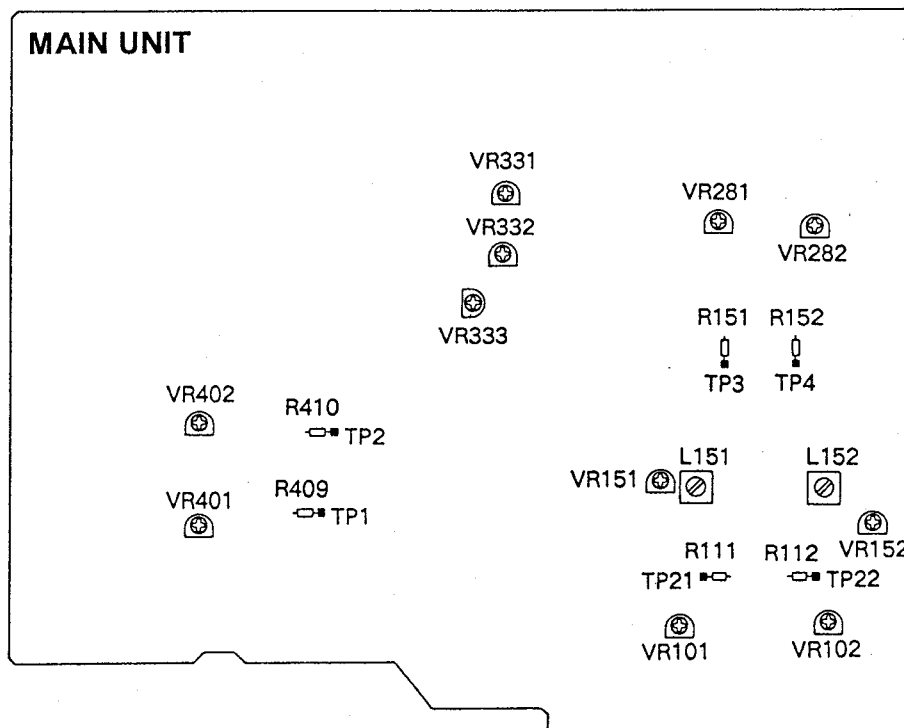

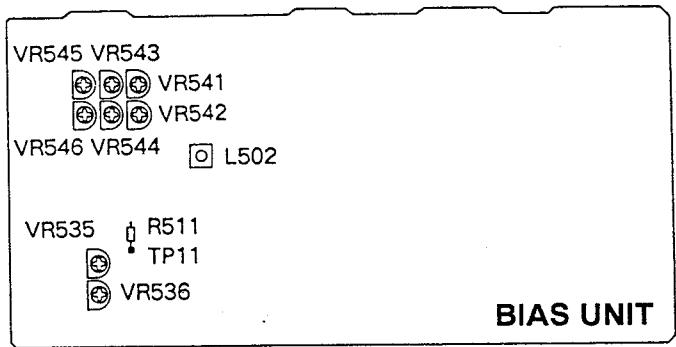

Fig. 6-4 Points réglage

SECTION D'ENREGISTREMENT

1. Réglage de l'oscillateur de polarisation

No.	Mode	Signal d'entrée et bande d'essai	Points de réglage		Points de mesure	Valeur de réglage	Remarques
1.	REC/PLAY	Charger la bande d'essai STD-610 et n'introduire aucun signal.	Platine	L502	TP. 11	210 kHz ± 600 Hz	

2. Réglage du circuit réjecteur de polarisation

No.	Mode	Signal d'entrée et bande d'essai	Points de réglage		Points de mesure	Valeur de réglage	Remarques
1.	REC/PLAY	Charger la bande d'essai STD-610 et n'introduire aucun signal.	Platine	L151 (can. G) L152 (can. D)	TP. 3 (can. G) TP. 4 (can. D)	Sortie minimum	

3. Réglage de la polarisation d'enregistrement

- Mettre l'interrupteur DOLBY HX PRO en circuit sur le panneau avant et régler la commande de polarisation BIAS sur la position centrale.

No.	Mode	Signal d'entrée et bande d'essai	Points de réglage		Points de mesure	Valeur de réglage	Remarques
1.	REC/PAUSE	Appliquer un signal de 315 Hz/-26 dBV (lecture du décibel-mètre -20) aux terminaux d'entrée de ligne et insérer STD-631.	-			-	
2.	REC → PLAY	Enregistrer et reproduire un signal de 315 Hz et un signal de 10 kHz à un niveau d'entrée de -26 dBV.	NOR	VR541 (can.G) VR542 (can.D)	LINE OUT	Enregistrer et reproduire continuellement, comparant les niveaux de lecture de 315 Hz et 10 kHz et régler à 0 ± 0,5 dB.	
3.		Enregistrer le signal de 10 kHz/315 Hz/-26 dBV sur STD-621 et reproduire.	CrO2	VR543 (can.G) VR544 (can.D)		0 dBV ± 0,5 dB	
4.		Enregistrer le signal 10 kHz/315 Hz/-26 dBV sur STD-610 et reproduire.	METAL	VR545 (can.G) VR546 (can.D)		0 dBV ± 0,5 dB	
5.	Vérifier la valeur de distorsion après avoir terminé le réglage et confirmer qu'il n'y a pas de sous polarisation.						
6.	Mettre l'interrupteur DOLBY HX PRO hors circuit.						
7.	REC → PLAY	Enregistrer et reproduire un signal de 315 Hz et un signal de 10 kHz à un niveau d'entrée de -26 dBV.	NOR	VR535 (can.G) VR536 (can.D)	LINE OUT	Tourner la commande à fond dans le sens contraire des aiguilles d'une montre. Puis la tourner graduellement vers la droite pour ajuster à 0 dB ± 0,5 dB comparé quand HX-Pro est en circuit.	Tourner la commande à droite au-delà de la crête pour assurer la valeur overbias correcte.

Régler dans l'ordre NOR → CrO2 → METAL. Après l'achèvement de tous les réglages, noter que la valeur de CrO2 et METAL sera modifiée si NOR est réajusté, et que celle de METAL le sera si CrO2 est réajusté.

4. Réglage du niveau d'enregistrement

- Mettre l'interrupteur DOLBY NR hors circuit.

No.	Mode	Signal d'entrée et bande d'essai	Points de réglage		Points de mesure	Valeur de réglage	Remarques
1.	REC/ PAUSE	Appliquer le signal 315 Hz/ -6 dBV à l'entrée de ligne et charger STD-631 (NORM).	Volume de la commande de niveau d'enregistrement.		TP. 1 (can. G) TP. 2 (can. D)	-11.2 dBV	
2.	REC → PLAY	Enregistrer et reproduire le signal 315 Hz/-6 dBV.	Platine	VR401 (can. G) VR402 (can. D)	TP. 3 (can. G) TP. 4 (can. D)	Enregistrer, reproduire et régler de manière répétée de sorte que le niveau du signal devienne -11.2 dBV.	L'enregistrement du réglage de polarisation et l'enregistrement du réglage de niveau avec STD-631 doivent être réalisés avec précision comme référence pour le réglage BLE.
3.	REC → PLAY	Enregistrer le signal 315 Hz/ -6 dBV sur STD-621 (CrO2) et le reproduire.	Vérifier			-11.2 dBV ± 1 dB	
4.	REC → PLAY	Enregistrer le signal 315 Hz/ -6 dBV sur STD-610 (METAL) et le reproduire.	Vérifier			-11.2 dBV ± 1 dB	

5. Réglage de l'indicateur de niveau

No.	Mode	Signal d'entrée et bande d'essai	Points de réglage	Points de mesure	Valeur de réglage	Remarques
1.	REC/ PAUSE	Appliquer un signal de 315 Hz/-6 dBV (318 mV) aux bornes d'entrée de ligne.	VR281 (can. G) VR282 (can. D)	TP. 1 (can. G) TP. 2 (can. D)	Toujours prévoir un mode supérieur lors du réglage. Faire en sorte que le segment 0 dB s'allume à un niveau de -11,2 ± 0,5 dBV (-11,2 ± 1,0 dBV en mode normal).	Ajuster en tournant dans le sens des aiguilles d'une montre jusqu'à ce que le témoin s'allume.

6. Réglage de AUTO BLE

- Le réglage de BLE doit être effectués que tous les autres réglages ont été complétés.
- Ce réglage doit être effectué dans le mode d'essai
- Introduction du mode d'essai

Appuyer simultanément sur les touches MODE (COUNTER), RANGE et MONITOR du panneau avant, lorsque l'unité est sous tension. L'unité est alors en mode d'essai et fait osciller un signal de 400 Hz. Dès lors, chaque fois que l'on appuie sur la touche START/CLEAR, la fréquence d'oscillation change comme suit: Oscillation 3 kHz → oscillation 15 kHz → relâchement.

No.	Mode	Signal d'entrée et bande d'essai	Points de réglage	Points de mesure	Valeur de réglage	Remarques
1.		REC LEVEL VR MIN (résistance variable du niveau d'enregistrement mini) ou pas d'entrée de signal.	-	-	-	
2.	-	Appuyer simultanément sur les trois touches MODE (COUNTER), RANGE et MONITOR du panneau avant.	VR331	Décibelmetre (can. D)	Ajuster afin que 0 dB sur le décibelmetre s'allume.	Réglage 400 Hz
3.		Appuyer une fois sur la touche START/CLEAR.	VR332		Ajuster afin que 0 dB sur le décibelmetre s'allume.	Réglage 3 kHz
4.		Appuyer une fois sur la touche START/CLEAR.	VR333		Ajuster afin que -3 dB sur le décibelmetre s'allume.	Réglage 15 kHz
5.	Lorsque la touche START/CLEAR est enfoncée à nouveau, le mode d'essai est relâché.					

6. AJUSTES

6.1 AJUSTES RELACIONADOS AL MECANISMO

1. Ajuste del azimut y movimiento de la cinta				2. Ajuste de velocidad de cinta		
N.	Mode	Punto de ajuste	Especificaciones	Modo	Punto de ajuste	Especificaciones
1	-	-	Inserte medio espejo en el lado A (fije los tornillos de delante).	PLAY	Orificio de ajuste del motor de cabrestante (vea la Fig. 3)	Ajuste de modo que la frecuencia de reproducción sea 3015 ± 5 Hz al comienzo del bobinado de la cinta de prueba STD-301.
2	PLAY	Tuerca de ajuste de altura (Consulte la figura 1.)	Reproduzca la cinta de arriba y ajústela de forma que no esté doblada en la sección guía de la cabeza. (Consulte la figura 2.)	PLAY	-	Reproduzca nuevamente la cinta de prueba STD-301 y confirme que las especificaciones de arriba sea satisfechas.
3	PLAY	Tornillo de ajuste de azimut (Consulte la figura 1.)	Reproduzca la cinta de prueba STD-331E y ajústela de forma que el nivel de salida de 10 kHz sea el máximo, y que no exista diferencia de fase entre el canal izquierdo y el canal derecho.			
4		Compruebe de nuevo el ítem 2 de arriba y ajuste si no se satisfacen las especificaciones. (Asegúrese de ajustar el ítem 3 después de haber ajustado el ítem 2.)				

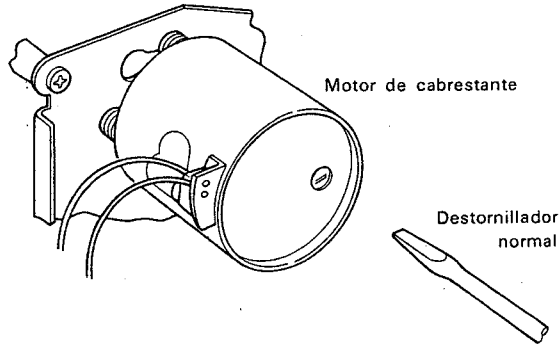

Fig. 3

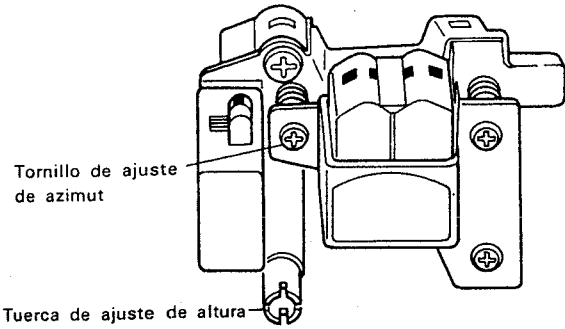

Fig. 1

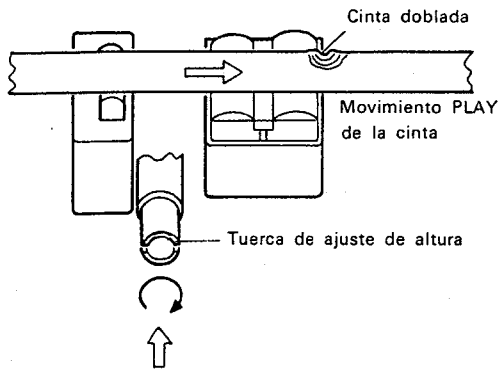

Fig. 2

6.2 AJUSTES ELÉCTRICOS

Condiciones de ajuste

1. Los ajustes mecánicos deben haberse completado primero.
2. La cabeza debe estar limpia y desmagnetizada.
3. Encienda la alimentación para permitir que la platina se caliente durante unos pocos minutos por lo menos antes de realizar cualquier ajuste eléctrico.
4. La señal de referencia es de 0 dBV=1 Vrms.
5. Conecte una resistencia de 50 kΩ (o entre 47k y 52 kΩ) en los terminales OUTPUT.
6. A menos que se especifique lo contrario, los conmutadores indicados más abajo deben dejarse en las posiciones indicadas.

DOLBY NR : OFF
 TAPE SELECTOR : NORM

Cintas de prueba

STD-331E : Ajustes de reproducción
 (Consulte la figura 6-1)
 STD-631 : Cinta virgen NORMAL
 STD-621 : Cinta virgen de CrO₂
 STD-610 : Cinta virgen de METAL



Figura 6-1 Constantes de la cinta de prueba STD-331E



Figura 6-2 Zona de respuesta de frecuencia

Lista de ajustes

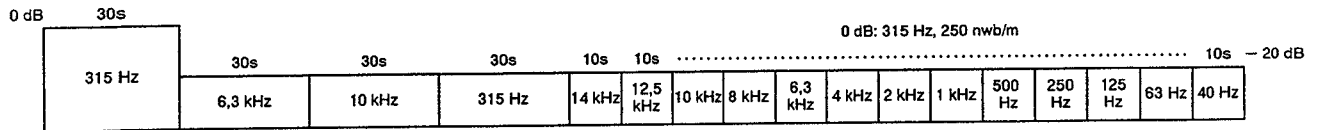
Secciones de reproducción

1. Ajuste de azimut de la cabeza
2. Ajuste del nivel de reproducción
3. Ajuste del equilibrio de CC

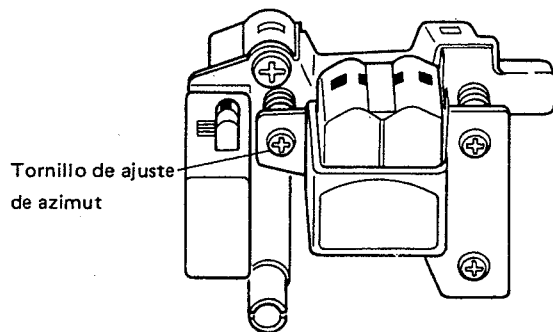
Secciones de grabación

1. Ajuste del oscilador de polarización
2. Ajuste del eliminador de polarización
3. Ajuste de la polarización de grabación
4. Ajuste del nivel de grabación
5. Ajuste del medidor de nivel
6. Ajuste BLE Automático

* Como el nivel de grabación de referencia es igual a 250 nwb/m para el STD-331E, el nivel de grabación será 4 dB mayor para el STD-331B (160 nwb/m). Al realizar el ajuste, preste suma atención al tipo de cinta que se está utilizando.



Figura 6-3 Ajuste de azimut de la cabeza

SECCIÓN DE REPRODUCCIÓN

1. Ajuste del azimut de la cabeza

- Poner VR105, 106 en las posiciones del centro mecánico.

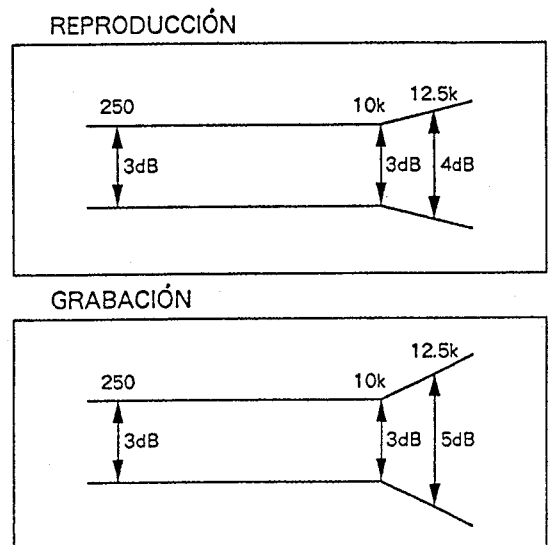
N.º	Modo	Señal de entrada y cinta de prueba	Punto de ajuste	Punto de medición	Valor de ajuste	Comentarios
1.	PLAY	Reproduzca la sección de 10 kHz/-20 dB de la cinta de prueba STD-331E.	Tornillo de ajuste del azimut de la cabeza. (Vea la figura 6-2)	LINE OUT	Nivel máximo de la señal de reproducción.	
2.	STOP	Bloquee el tornillo con su cierre una vez finalizado el ajuste.				

2. Ajuste del nivel de reproducción

N.º	Modo	Señal de entrada y cinta de prueba	Punto de ajuste	Punto de medición	Valor de ajuste	Comentarios
1.	PLAY	Produzca la parte de 315 Hz/0 dB de la cinta de prueba STD-331E.	Platina VR151 (Lch) VR152 (Rch)	TP. 3 (Lch) TP. 4 (Rch)	-11,0 dBV	Este ajuste debe efectuarse con precisión para lograr un buen reglaje del nivel Dolby.

3. Ajuste del equilibrio de CC

N.º	Modo	Señal de entrada y cinta de prueba	Punto de ajuste	Punto de medición	Valor de ajuste	Comentarios
1.			VR101 (Lch) VR102 (Rch)	TP. 21 (Lch) TP. 22 (Rch)	0V ± 0,2V	

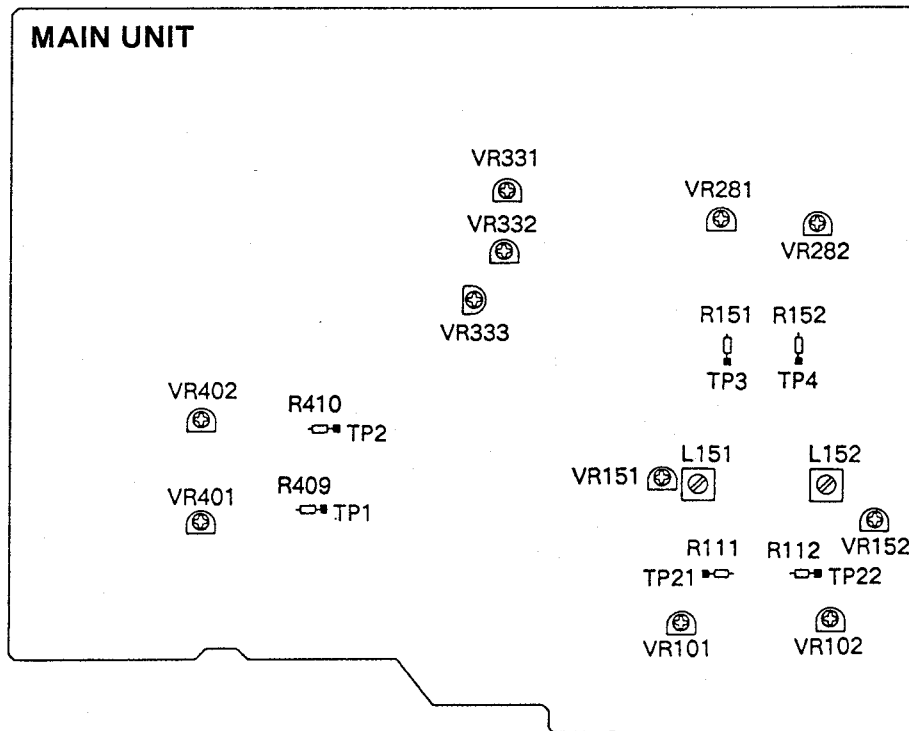



Figura. 6-4 Puntos de ajuste

SECCIÓN DE GRABACIÓN

1. Ajuste del oscilador de polarización

N.º	Modo	Señal de entrada y cinta de prueba	Punto de ajuste		Punto de medición	Valor de ajuste	Comentarios
1.	REC/ PLAY	Introduzca la cinta de prueba STD-810 sin señal de entrada.	Platina	L502	TP. 11	210 kHz ± 600 Hz	

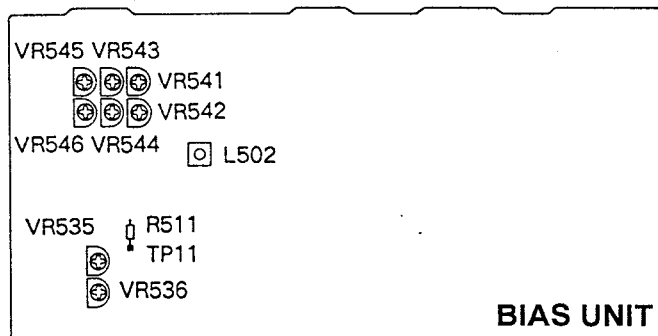
2. Ajuste del eliminador de polarización

N.º	Modo	Señal de entrada y cinta de prueba	Punto de ajuste		Punto de medición	Valor de ajuste	Comentarios
1.	REC/ PLAY	Introduzca la cinta de prueba STD-810 sin señal de entrada.	Platina	L151 (Lch) L152 (Rch)	TP. 3 (Lch) TP. 4 (Rch)	Salida mínima	

3. Ajuste de la polarización de grabación

- Conecte el interruptor DOLBY HX PRO del panel delantero y coloque el control BIAS en la posición central.

N.º	Modo	Señal de entrada y cinta de prueba	Punto de ajuste		Punto de medición	Valor de ajuste	Comentarios
1.	REC/ PAUSE	Aplique una señal de 315 Hz/-26 dBV (dando una lectura de -20 UV en el medidor de volumen) a los terminales de entrada de línea, e inserte el casete STD-831.	-		LINE OUT	-	
2.	REC → PLAY	Grabe y reproduzca la señal de 315 Hz y una señal de 10 kHz a un nivel de entrada de -26 dBV.	NOR	VR541 (L ch) VR542 (R ch)		Grabe y reproduzca repetidamente, comparando los niveles de reproducción 315 Hz y 10 kHz, y ajuste a 0 ± 0,5 dB.	
3.		Grabe la señal de 10 kHz /315 Hz -26 dBV en la cinta STD-821, y reproduzca.	CrO2	VR543 (L ch) VR544 (R ch)		0 dBV ± 0,5 dB	
4.		Grabe la señal de 10 kHz /315 Hz, -26 dBV en la cinta STD-810, y reproduzca.	METAL	VR545 (L ch) VR546 (R ch)		0 dBV ± 0,5 dB	
5.	Verifique el valor de la distorsión una vez finalizado el ajuste y confirme que no haya subpolarización.						
6.	Desconecte el interruptor DOLBY HX PRO.						
7.	REC → PLAY	Grabe y reproduzca la señal de 315 Hz y una señal de 10 kHz a un nivel de entrada de -26 dBV.	NOR	VR535 (L ch) VR536 (R ch)	LINE OUT	Gire el control completamente hacia la izquierda y luego gírelo gradualmente a la derecha para ajustar a 0 dB ± 0,5 dB cuando HX-PRO está conectado.	Gire el control en sentido horario hasta pasar el pico para asegurar un correcto valor de sobrepolarización.

Ajuste en el orden siguiente: NOR → CrO2 → METAL. Después de completar todos los ajustes, observe que los valores de ajuste para CrO2 y METAL se alterarán si se reajusta NOR, y que para METAL se alterarán si se reajusta CrO2.

4. Ajuste del nivel de grabación

- Desconecte el interruptor DOLBY NR.

N.º	Modo	Señal de entrada y cinta de prueba	Punto de ajuste		Punto de medición	Valor de ajuste	Comentarios
1.	REC/ PAUSE	Aplique la señal de 315 Hz/-6 dBV a la entrada line y cargue STD-631 (NORM).	Control de nivel de grabación.		TP. 1 (Lch) TP. 2 (Rch)	-11.2 dBV	
2.	REC → PLAY	Grabe y reproduzca la señal de 315 Hz/-6 dBV.	Platina	VR401 (Lch) VR402 (Rch)	TP. 3 (Lch) TP. 4 (Rch)	Grabe, reproduzca y ajuste repetidamente para que el nivel de la señal de reproducción sea de -11.2 dBV.	El ajuste de la polarización de grabación y el ajuste del nivel de grabación con STD-631 debe efectuarse con precisión para que sirva como referencial al ajuste BLE.
3.	REC → PLAY	Grabe la señal de 315 Hz/-6 dBV en STD-621 (CrO2) y reproduzca.	Verifique			-11.2 dBV ± 1 dB	
4.	REC → PLAY	Grabe la señal de 315 Hz/-6 dBV en STD-610 (METAL) y reproduzca.	Verifique			-11.2 dBV ± 1 dB	

5. Ajuste del medidor de nivel

N.º	Modo	Señal de entrada y cinta de prueba	Punto de ajuste	Punto de medición	Valor de ajuste	Comentarios
1.	REC/ PAUSE	Aplique una señal de 315 Hz/-6 dBV (316 mV) a los terminales de entrada de línea.	VR281 (Lch) VR282 (Rch)	TP. 1 (Lch) TP. 2 (Rch)	Seleccione siempre el modo aumentado para el ajuste. Ajuste de modo que el segmento de 0 dB se ilumine a un nivel de -11,2 ± 0,5 dBV (-11,2 ± 1,0 dBV en el modo normal).	Ajuste girando hacia la derecha hasta que la luz se encienda.

6. Ajuste BLE Automático

- El ajuste BLE debe efectuarse después de haber terminado todos los otros ajustes.
- Este ajuste debe efectuarse en el modo de prueba.
- Cómo establecer el modo de prueba.

Pulse simultáneamente las teclas MODE (COUNTER), RANGE y MONITOR del panel delantero con la alimentación encendida.

La unidad entrará en el modo de prueba y oscilará una señal de 400 Hz. De aquí en adelante, cada vez que pulse la tecla START/CLEAR, la frecuencia de oscilación cambiará de la forma siguiente: Oscilación de 3 kHz → Oscilación de 15 kHz → Liberación.

N.º	Modo	Señal de entrada y cinta de prueba	Punto de ajuste	Punto de medición	Valor de ajuste	Comentarios
1.		VR del nivel de grabación mínimo o sin entrada de señal.	-	-	-	
2.		Pulse simultáneamente las tres teclas MODE (COUNTER), RANGE y MONITOR del panel delantero.	VR331	Medidor de nivel Rch	Ajuste de modo que se ilumine 0 dB en el medidor de nivel.	Ajuste de 400 Hz
3.		Pulse la tecla START/CLEAR una vez.	VR332		Ajuste de modo que se ilumine 0 dB en el medidor de nivel.	Ajuste de 3 kHz
4.		Pulse la tecla START/CLEAR una vez.	VR333		Ajuste de modo que se ilumine -3 dB en el medidor de nivel.	Ajuste de 15 kHz
5.	Cuando la tecla START/CLEAR se pulse de nuevo, se soñará el modo de prueba.					

7. SPECIFICATIONS

System	4 track, 2-channel stereo
Heads	
Recording and playback head:	
Laser amorphous playback head and Laser amorphous recording head combination × 1	
Motor	DC servo capstan motor × 1 DC reel motor × 1 DC auxiliary motor × 1
Wow and Flutter	No more than 0.022% (WRMS) No more than ±0.052% (DIN)
Fast Winding Time	Approximately 75 seconds (C-60 tape)
Frequency Response	
-20 dB recording:	
TYPE IV (Metal) tape	15 to 23,000 Hz ±6 dB
TYPE II (HIGH/CrO ₂) tape	15 to 21,000 Hz ±6 dB
TYPE I (Normal) tape	15 to 21,000 Hz ±6 dB
Signal-to-Noise Ratio (Dolby NR off)	More than 63 dB
Noise Reduction Effect	
Dolby B-type NR ON	More than 10 dB (at 5 kHz)
Dolby C-type NR ON	More than 19 dB (at 5 kHz)
Harmonic Distortion	No more than 0.6% (-4 dB)
Input (Sensitivity)	
LINE (INPUT)	95 mV (Input impedance 47 kΩ)
Output (Reference level)	
LINE (OUTPUT)	0.5 V (Output impedance 1.8 kΩ)
Headphone	5.5 mW (Load impedance 8 Ω, PHONES LEVEL control max.)

Subfunctions

- Super AUTO BLE system
- Bias control
- Dolby HX Pro Headroom Extension system (on/off possible)
- Dolby B-type and C-type noise reduction systems
- MPX filter
- Level meter with 2 modes peak hold selection (16 + 1 segments)
- Level meter range selection (wide/expanded)
- Peak level calibration system
- 4-digit electronic tape counter with mode selection
- Auto monitor selection (Tape/Source)
- Display off
- Music search (over ±15 selections)
- Automatic Tape Loose Canceller (ATLC)
- Tape return/Return play
- Auto space recording mute
- Auto tape selector
- Line straight
- Playback/recording timer start function
- CD•DECK SYNCHRO recording
- Headphones jack with level control
- Power eject (Open/Close)
- Repeat playback
- Last memory

Miscellaneous

Power Requirements	AC 220-230 Volts~, 50/60 Hz
Power Consumption	25W
Dimensions	420(W) × 146(H) × 375(D) mm
Weight (without package)	8.2 kg

Accessories

Operating instructions	1
Connection cord with pin plugs	2
CD•DECK SYNCHRO control cord	1

NOTE:

Specifications and design subject to possible modifications without notice, due to improvements.

8. PANEL FACILITIES

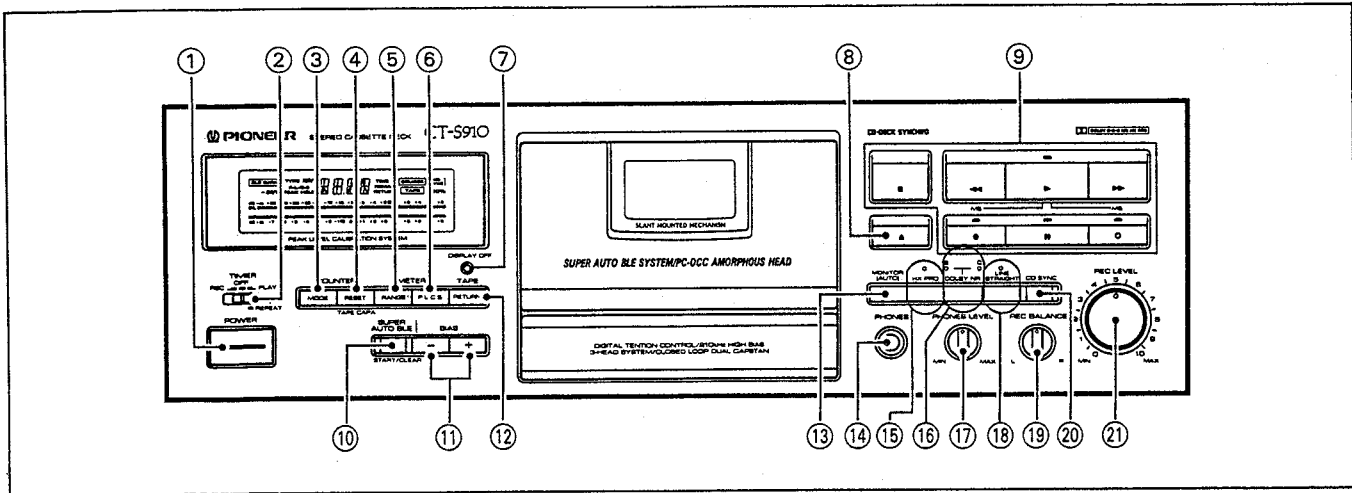

① Power switch (POWER)

After pressing the switch, the WAIT message will appear in the counter display and the level meter scale will flash for about four seconds (the time necessary for circuitry to stabilize). During the time the display is flashing, no operating buttons will respond, with the exception of the cassette door open/close button (▲). When closing the cassette door, do so while the power is turned on.

② Timer mode/repeat play switch (TIMER)

REC: Set to this position to perform timer recording.
OFF: Set to this position under ordinary conditions, (when not using the timer or repeat functions).
PLAY/REPEAT:

Set to this position to perform timer playback. When the switch is set to this position during normal playback, repeat playback of a single tape can be performed.

③ Counter mode button (COUNTER MODE)

Each time this button is pressed, one of the three mode (Normal tape counter/Time counter/Remaining time counter) is set in sequence.

④ Counter reset/Tape capacity selector button (COUNTER RESET/TAPE CAPA)

Reset the counter indication to "0000" in the normal tape counter or the time counter mode.

To indicate the correct time value in the remaining time counter mode, this button must be set in accordance with the tape used.

⑤ Level meter range selector button (METER RANGE)

Switches between wide range, expanded range, and bias display.

⑥ Meter PLCS button (METER PLCS)

Selects the display mode of the peak level.
 When press this button so that the PEAK HOLD indicator lights up, the level meter holds the maximum level indications of the signal. To erase the maximum level indications, press this button again. When the PEAK HOLD indicator goes off, the level meter holds peak indications for about 1.2 second.

In addition to the peak level display noted above, the button can also be used with the peak level calibration system to adjust tape recording levels.

⑦ Display off button (DISPLAY OFF)

Press this button to turn off the function display.

⑧ Open/close button (▲)

Press this button to open or close the cassette door. Whenever inserting or removing a cassette tape, be sure that the power is turned on.

NOTE:

If the cassette door is closed while the unit is turned off, and the power is then turned on, the cassette door may open and close after pressing one of the operation buttons. This occurs when the microprocessor resets the door mechanism to its initial state and does not indicate any malfunctioning of the unit.

⑨ Operation buttons

- : Stop
- ◀/MS : Rewind/music search
- ▶ : Playback
- ▶▶/MS : Fast forward/music search
- : Recording
- ⏸ : Pause
- : Recording mute

⑩ SUPER AUTO BLE START/CLEAR button

⑪ Recording bias buttons (BIAS -/+)

When desired, these buttons can be used to manually adjust the recording bias after performing AUTO BLE tuning.

- : Changes tone by reducing recording bias
- + : Changes tone by increasing recording bias

⑫ Tape return button (TAPE RETURN)

This button is used in the normal tape counter mode to fast forward or rewind the tape to a point near the counter reading "0000."

⑬ Monitor selector button (MONITOR [AUTO])

Used to monitor the source sound or just recorded sound during recording.

- When the unit is set to record or playback mode, the TAPE indicator light up and the monitor mode is automatically selected.

⑭ Headphones jack (PHONES)

⑮ DOLBY* HX PRO ON/OFF button/indicator

The indicator lights when the button is in the ON position.

⑩ **DOLBY NR B/C select button/indicator**

Use to switch between DOLBY B type NR and DOLBY C type NR.

→OFF→B→C→

*

- *Dolby noise reduction and HX Pro headroom extension manufactured under license from Dolby Laboratories Licensing Corporation. HX Pro originated by Bang & Olufsen.*
- *"DOLBY", the double-D symbol  and "HX PRO" are trademarks of Dolby Laboratories Licensing Corporation.*

⑪ **Headphones level control (PHONES LEVEL)**

⑫ **Line straight button/indicator (LINE STRAIGHT)**

When this button is pressed so that the indicator lights, sound signals bypass the REC BALANCE controls circuits. This allows enhanced clarity of recording.

⑬ **Recording balance control (REC BALANCE)**

⑭ **CD•DECK SYNCHRO recording button (CD SYNC)**

⑮ **Recording level control (REC LEVEL)**

ATLC (Automatic Tape Loose Canceller)

With the tape slack prevention function, when the cassette door closes, the take-up reel automatically revolves to eliminate any tape slack.

SUPER AUTO BLE

With commercially available cassette tapes, sensitivity and frequency characteristics might differ slightly from one another, even though the same sound adjustment is set for them. To utilize tape characteristics to the maximum possible and realize an ideal recording which reproduces the source exactly, optimum recording level (sensitivity) and equalizer values must be set accordingly for each tape. In many conventional tape decks, standard values are fixed for standard tapes, thus nullifying the subtle differences between individual tapes. Perfect tuning by ear through use of fine adjustment controllers for bias and sensitivity is difficult and requires a lot of effort.

The AUTO BLE on this unit automatically adjusts bias, level and equalizer by using a microprocessor to set the optimum recording characteristics accordingly for each tape.

The recording bias is adjusted with 64 steps at 15 kHz. The recording level is adjusted with 32 steps at 400 Hz. The recording equalizers are adjusted with 16 steps at 3 kHz and with 4 steps at 15 kHz.