

3736

# Service Manual

ORDER NO.  
ARP2509

## STEREO CASSETTE DECK

# CT-S510 CT-S410

### CT-S510 AND CT-S410 HAVE THE FOLLOWING:

Type	Model		Power Requirement	Remarks
	CT-S510	CT-S410		
KUC	-	○	AC120V only	
HEM	○	○	AC220-230V, 230-240V (switchable) *	
HB	○	○	AC220-230V, 230-240V (switchable) *	

\*Change the connection of the power transformer's primary wiring.

- This manual is applicable to CT-S510/HEM, HB, CT-S410/KUC, HEM and HB types.
- For the following: CT-S510/HB, CT-S410/KUC, HEM, and HB types, refer to page 41.
- Ce manuel pour le service comprend les explications de réglage en français.
- Este manual de servicio trata del método ajuste escrito en español.

### CONTENTS

1. SAFETY INFORMATION .....	2	8. MODE D'ESSAI .....	27
2. SPECIFICATIONS .....	3	8. MODO DE PRUEBA .....	28
3. EXPLODED VIEWS AND PARTS LIST .....	4	9. ADJUSTMENTS .....	29
4. PACKING AND PARTS LIST .....	10	9. REGLAGES .....	33
5. PCB CONNECTIONS DIAGRAM .....	11	9. AJUSTES .....	37
6. SCHEMATIC DIAGRAM .....	19	10. FOR CT-S510/HB, CT-S410/KUC, HEM AND HB TYPES .....	41
7. PCB PARTS LIST .....	22	11. PANEL FACILITIES .....	43
8. TEST MODE .....	26		

3739

This service manual is intended for qualified service technicians; it is not meant for the casual do-it-yourselfer. Qualified technicians have the necessary test equipment and tools, and have been trained to properly and safely repair complex products such as those covered by this manual.

Improperly performed repairs can adversely affect the safety and reliability of the product and may void the warranty. If you are not qualified to perform the repair of this product properly and safely, you should not risk trying to do so and refer the repair to a qualified service technician.

**WARNING**

Lead in solder used in this product is listed by the California Health and Welfare agency as a known reproductive toxicant which may cause birth defects or other reproductive harm (California Health & Safety Code, Section 25249.5).

When servicing or handling circuit boards and other components which contain lead in solder, avoid unprotected skin contact with the solder. Also, when soldering do not inhale any smoke or fumes produced.

# 1. SAFETY INFORMATION

(FOR USA MODEL ONLY)

## 1. SAFETY PRECAUTIONS

The following check should be performed for the continued protection of the customer and service technician.

### LEAKAGE CURRENT CHECK

Measure leakage current to a known earth ground (water pipe, conduit, etc.) by connecting a leakage current tester such as Simpson Model 229-2 or equivalent between the earth ground and all exposed metal parts of the appliance (input/output terminals, screwheads, metal overlays, control shaft, etc.). Plug the AC line cord of the appliance directly into a 120V AC 60Hz outlet and turn the AC power switch on. Any current measured must not exceed 0.5mA.

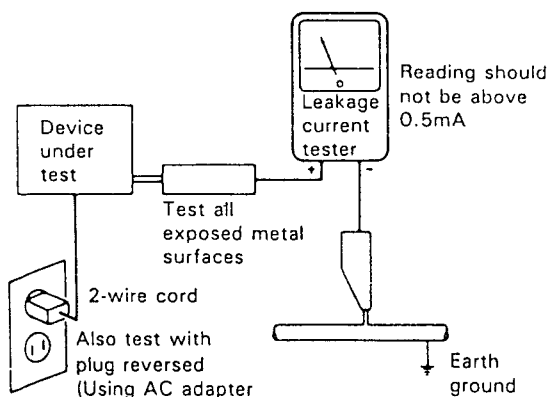

AC Leakage Test

ANY MEASUREMENTS NOT WITHIN THE LIMITS OUTLINED ABOVE ARE INDICATIVE OF A POTENTIAL SHOCK HAZARD AND MUST BE CORRECTED BEFORE RETURNING THE APPLIANCE TO THE CUSTOMER.

## 2. PRODUCT SAFETY NOTICE

Many electrical and mechanical parts in the appliance have special safety related characteristics. These are often not evident from visual inspection nor the protection afforded by them necessarily can be obtained by using replacement components rated for voltage, wattage, etc. Replacement parts which have these special safety characteristics are identified in this Service Manual.

Electrical components having such features are identified by marking with a  $\Delta$  on the schematics and on the parts list in this Service Manual.

The use of a substitute replacement component which does not have the same safety characteristics as the PIONEER recommended replacement one, shown in the parts list in this Service Manual, may create shock, fire, or other hazards.

Product Safety is continuously under review and new instructions are issued from time to time. For the latest information, always consult the current PIONEER Service Manual. A subscription to, or additional copies of, PIONEER Service Manual may be obtained at a nominal charge from PIONEER.

## 2. SPECIFICATIONS

System .....	4 track, 2-channel stereo
Heads .....	Combined "Hard permalloy" recording/playback head × 1 "Ferrite" erasing head × 1
Motor .....	DC servo capstan motor × 1 DC reel motor × 1
Wow and Flutter .....	No more than 0.05% (WRMS, JIS) No more than ±0.14% (DIN)
Fast Winding Time .....	Approx. 90 seconds (C-60 tape)
Frequency Response (at -20 dB recording level)	
TYPE IV (Metal) Tape .....	20 to 21,000 Hz
TYPE II (CrO <sub>2</sub> ) Tape .....	20 to 19,000 Hz
TYPE I (Normal) Tape .....	20 to 19,000 Hz
Signal-to-Noise Ratio (Dolby NR off) .....	More than 59 dB
Noise Reduction Effect	
Dolby B-type NR ON .....	More than 10 dB (at 5 kHz)
Dolby C-type NR ON .....	More than 19 dB (at 5 kHz)
Harmonic Distortion .....	No more than 0.6% (at -4 dB: 160 nwb/m)
Input (Sensitivity)	
LINE (INPUT) .....	100 mV (Input impedance 50 kΩ)
Output (Reference level)	
LINE (OUTPUT) .....	0.5 V (Output impedance 3.8 kΩ)
Headphone (PHONES) .....	0.63 mW (Load impedance 8 Ω)

### Miscellaneous

Power Requirements	
U.S., Canadian models .....	AC 120V, 60 Hz
U.K., model .....	AC 230-240 Volts~, 50/60 Hz
European model .....	AC 220-230 Volts~, 50/60 Hz
Power Consumption .....	23W
Dimensions .....	420(W) × 126(H) × 272(D) mm 16-9/16(W) × 4-15/16(H) × 10-11/16(D) in
Weight	
[CT-S510] .....	4.5 kg (9lb 14/16oz.)
[CT-S410] .....	4.5 kg (9lb 14/16oz.)

### Subfunctions

- Dolby B-type and C-type NR Systems
- DOLBY HX PRO system
- MPX FILTER
- Headphones jack
- 4-digit electronic tape/time/remain counter (Displays the operation mode in 5 digits)
- Music search up to ±15 selections
- Automatic space recording mute
- SUPER AUTO BLE tuning system
- FL level meter 9 + 1 segments (with peak hold)
-  System remote control available (CT-S410 only)
- CD•DECK SYNCHRO function
- Timer Recording/Playback (Automatic repeat playback ON)
- SOUND EQ
- Auto tape selector

### Accessories

Operating instructions .....	1
Connection cord with pin plugs .....	2
Remote control unit (CT-S510 only) .....	1
Batteries (CT-S510 only) .....	2
 Remote control cord (CT-S410 only) .....	1
CD•DECK SYNCHRO control cord .....	1

### NOTE:

*Specifications and design subject to possible modifications without notice, due to improvements.*

### 3. EXPLODED VIEWS AND PARTS LIST

**NOTES:**

- Parts marked by "NSP" are generally unavailable because they are not in our Master Spare Parts List.
- The  $\Delta$  mark found on some component parts indicates the importance of the safety factor of the part. Therefore, when replacing, be sure to use parts of identical designation.
- Parts marked by "⊙" are not always kept in stock. Their delivery time may be longer than usual or they may be unavailable.

#### 3.1 EXTERIOR (For CT-S510/HEM type)

**Parts List**

Mark	No.	Description	Part No.	Mark	No.	Description	Part No.
$\Delta$	1	Strain relief	CM - 22B		41	.....	
$\Delta$	2	AC power cord	PDG1003		42	Screw	BCZ30P060FMC
$\Delta$	3	Fuse (1A) (FU803)	REK - 100		43	.....	
	4	.....			44	Screw	IBZ30P150FCU
$\Delta$	5	Power transformer (T1)	RTT1195		45	Screw	PMA30P060FMC
	6	Cord clamper (KUC only)	RNH - 184		46	Screw	FBT40P080FZK
	7	Ratchet spring	RBH1008		47	Screw	BBZ30P060FZK
	8	Push spring	RBH1146		48	Binder	REC - 371
	9	Door spring (L)	RBH1203		49	Lead card 18P	RDD1258
	10	Half pressure spring	RBK1004		50	Lead card 20P	RDD1259
	11	FL holder	RNK1499	NSP	101	MAIN unit	RWZ2589
	12	Damper assembly	REC1013	NSP	102	DISP unit	RWZ2590
	13	Insulator	VNK1095	NSP	103	HPHN unit	RWZ2581
	14	Knob	RAC1604	NSP	104	TIMS unit	RWZ2582
	15	Slide knob (A)	RAC1236	NSP	105	PWSW unit	RWZ2580
	16	VR knob	RAC1363	NSP	106	TRN 2 unit	RWZ2586
	17	Power button	RAC1364		107	.....	
	18	Operation knob	RAC1682	NSP	108	PCB spacer	PNY - 404
	19	Headphone knob	RAC1366	NSP	109	.....	
	20	Eject knob	RAC1367	NSP	110	Main chassis	RNB1076
	21	Slide knob (B)	RAC1392	NSP	111	Headphone bracket	RNE1178
	22	Tact knob	RAC1409	NSP	112	Mechanism mount plate (U)	RNE1307
	23	Counter reset knob	RAC1400				
	24	Stabilizer panel	RAH1483	NSP	113	Mechanism mount plate (D)	RNE1308
⊙	25	Mechanism unit	RYM1167	NSP	114	Name plate	PAN1035
	26	Decoration screw	RAT1001	NSP	115	Rear panel	RNA1514
	27	Stabilizer B	REB1085				
	28	Remain display paper	REE - 113	NSP	116	Front panel	RNT1131
	29	Door pocket	RNT1145	NSP	117	TRN 1 unit	RWZ2678
	30	Stopper	VEC1061	NSP	118	Regulator IC unit	RWZ2671
	31	Door lens	RAH1244	NSP	119	Connector assembly 4P	RKP1111
	32	Dolby name plate	RAH2003	NSP	120	Trans shield plate	RNE1451
	33	Door panel	RAH1996	NSP	121	Connector assembly 6P	RKP1506
	34	FL lens	RAH2030	NSP	122	Capacitor sleeve A	REC - 150
	35	.....		NSP	123	PCB spacer	REB1072
	36	Bonnet	RXX1396				
	37	Front panel assembly	RXX1466				
	38	Screw	ABZ26P050FMC				
	39	Screw	BBZ30P080FCC				
	40	Screw	ARZ26P060FMC				

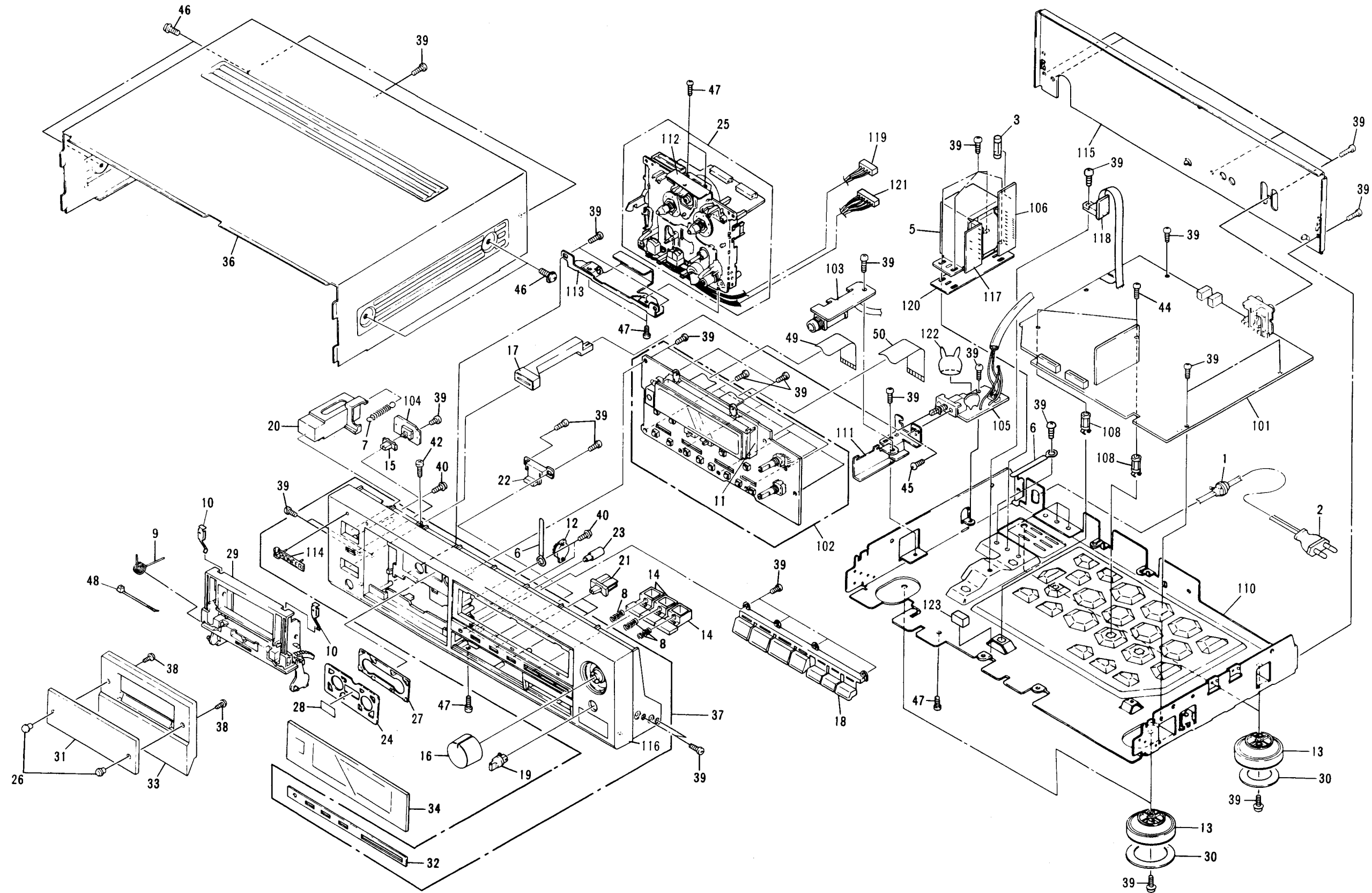

3.1 MECHANISM UNIT (RYM1167)

A

B

C

D

A

B

C

D

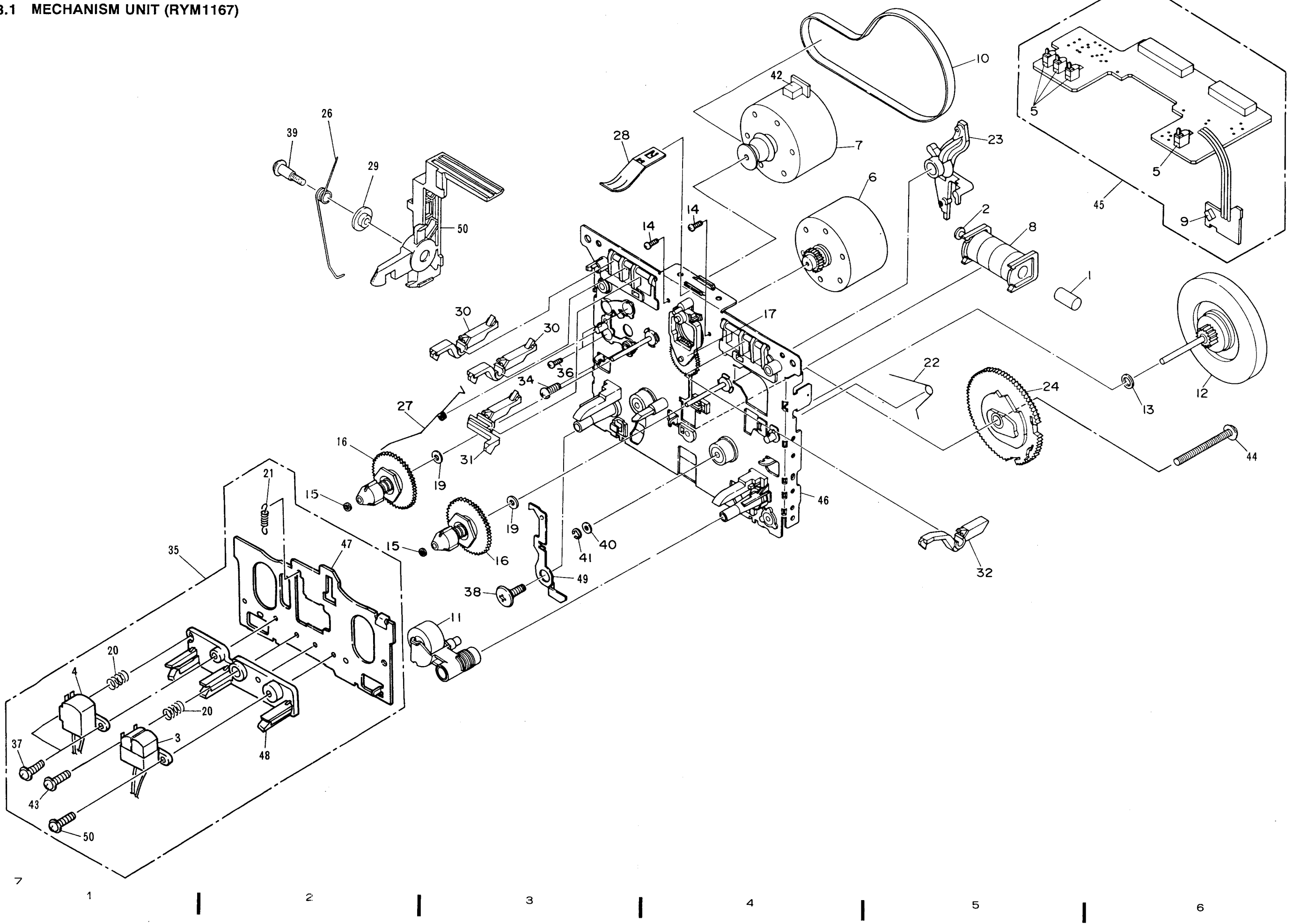

## Parts List

Mark	No.	Description	Part No.
	1	Fixed core	RLA1130
	2	Planger	RLA1132
	3	Head (R/P)	RPB1047
	4	Head (E)	RPB1040
	5	Push SW	RSG1018
	6	MTR reel BLK	RXM1057
	7	MTR main BLK	RXM1058
	8	Solenoid BLK	RXP1010
	9	Photo - transistor	SPI33534FG
	10	Main belt	REB1163
	11	Pinch roller ass'y	RXA1183
	12	F/W ass'y	RXA1346
	13	Washer	WA26D045D025
	14	Pan 2.6 x 6.4 ZN	RBA1076
	15	Washer	RBF - 057
	16	Reel base BLK	RXA1184
	17	Idler BLK	RXA1248
	18	.....	
	19	Washer	RBF1038
	20	Azimuth SP	RBH1076
	21	Head base SP	RBL1003
	22	Slide SP	RBH1239
	23	Play arm	RNK1525
	24	Cam gear (3R)	RNK1672
	25	.....	
	26	Lever SP (L) (EJECT)	RBH1262
	27	Eject prevention spring (L)	RBH1234
	28	Spring (CASSETTE)	RBK1031
	29	Lever (Collar B)	RLA1146
	30	Detector lever (REC)	RNK1527
	31	Metal detector lever (L)	RNK1529
	32	Detector lever (P)	RNK1543
	33	.....	
	34	Screw	RBA1101
	35	Plate HD BLK	RXA1488
	36	Screw	PMA26P050FMC
	37	F lock screw	RBA1031
	38	Screw (7.7)	RBA1048
	39	Screw	RBA1078
	40	Washer	WA26D047D050
	41	Washer	YE15FUC
	42	Holder cushion (L)	RED1027
	43	F lock screw	RBA1102
	44	Screw	RBA1068
	45	PCB control BLK	RXA1487
	46	Chassis base BLK	RXA1345
	47	Head base	RNE1390
	48	Head spacer	RNK1836
	49	Eject prevention arm (L)	RNE1199
	50	Lever (L) (EJECT)	RNK1593
	50	Screw	PMZ20P080FMC

## 4. PACKING AND PARTS LIST

**NOTES:**

- Parts marked by "NSP" are generally unavailable because they are not in our Master Spare Parts List.
- The  $\Delta$  mark found on some component parts indicates the importance of the safety factor of the part. Therefore, when replacing, be sure to use parts of identical designation.
- Parts marked by "⊙" are not always kept in stock. Their delivery time may be longer than usual or they may be unavailable.

**Parts List**

Mark	No.	Description	Part No.
	1	Pad (A)	RHA1006
	2	Pad (B)	RHA1007
	3	Packing case	RHG1324
	4	Sheet	RHX - 034
	5	Connection cord	RDE - 010
	6	Control cord	RDE1030
	7	Operating instructions (German/Italian/Dutch/ Swedish/Spanish/Portuguese)	RRD1131
		Operating instructions (English/French)	RRE1054
	8	Vinyl bag	RHL1001
	9	Remote control unit	RPX1059
	10	Battery cover	PZN1010
NSP	101	Connection cord assembly	RDE1002
NSP	102	Dry cell battery (R03, AAA)	VEM - 022

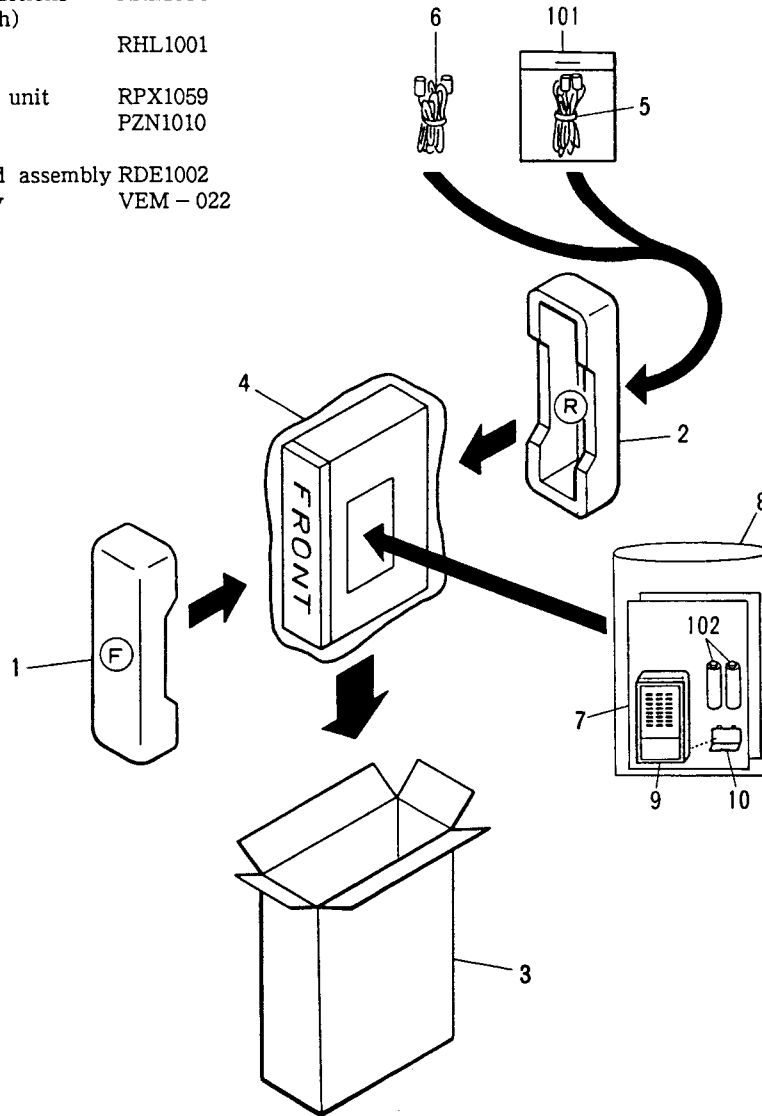



## Parts List

Mark	No.	Description	Part No.
	1	Fixed core	RLA1130
	2	Planger	RLA1132
	3	Head (R/P)	RPB1047
	4	Head (E)	RPB1040
	5	Push SW	RSG1018
	6	MTR reel BLK	RXM1057
	7	MTR main BLK	RXM1058
	8	Solenoid BLK	RXP1010
	9	Photo - transistor	SPI33534FG
	10	Main belt	REB1163
	11	Pinch roller ass'y	RXA1183
	12	F/W ass'y	RXA1346
	13	Washer	WA26D045D025
	14	Pan 2.6 x 6.4 ZN	RBA1076
	15	Washer	RBF - 057
	16	Reel base BLK	RXA1184
	17	Idler BLK	RXA1248
	18	.....	
	19	Washer	RBF1038
	20	Azimuth SP	RBH1076
	21	Head base SP	RBL1003
	22	Slide SP	RBH1239
	23	Play arm	RNK1525
	24	Cam gear (3R)	RNK1672
	25	.....	
	26	Lever SP (L) (EJECT)	RBH1262
	27	Eject prevention spring (L)	RBH1234
	28	Spring (CASSETTE)	RBK1031
	29	Lever (Collar B)	RLA1146
	30	Detector lever (REC)	RNK1527
	31	Metal detector lever (L)	RNK1529
	32	Detector lever (P)	RNK1543
	33	.....	
	34	Screw	RBA1101
	35	Plate HD BLK	RXA1488
	36	Screw	PMA26P050FMC
	37	F lock screw	RBA1031
	38	Screw (7.7)	RBA1048
	39	Screw	RBA1078
	40	Washer	WA26D047D050
	41	Washer	YE15FUC
	42	Holder cushion (L)	RED1027
	43	F lock screw	RBA1102
	44	Screw	RBA1068
	45	PCB control BLK	RXA1487
	46	Chassis base BLK	RXA1345
	47	Head base	RNE1390
	48	Head spacer	RNK1836
	49	Eject prevention arm (L)	RNE1199
	50	Lever (L) (EJECT)	RNK1593
	50	Screw	PMZ20P080FMC

## 4. PACKING AND PARTS LIST

**NOTES:**

- Parts marked by "NSP" are generally unavailable because they are not in our Master Spare Parts List.
- The  $\Delta$  mark found on some component parts indicates the importance of the safety factor of the part. Therefore, when replacing, be sure to use parts of identical designation.
- Parts marked by "⊙" are not always kept in stock. Their delivery time may be longer than usual or they may be unavailable.

**Parts List**

Mark	No.	Description	Part No.
	1	Pad (A)	RHA1006
	2	Pad (B)	RHA1007
	3	Packing case	RHG1324
	4	Sheet	RHX - 034
	5	Connection cord	RDE - 010
	6	Control cord	RDE1030
	7	Operating instructions (German/Italian/Dutch/ Swedish/Spanish/Portuguese)	RRD1131
		Operating instructions (English/French)	RRE1054
	8	Vinyl bag	RHL1001
	9	Remote control unit	RPX1059
	10	Battery cover	PZN1010
NSP	101	Connection cord assembly	RDE1002
NSP	102	Dry cell battery (R03, AAA)	VEM - 022

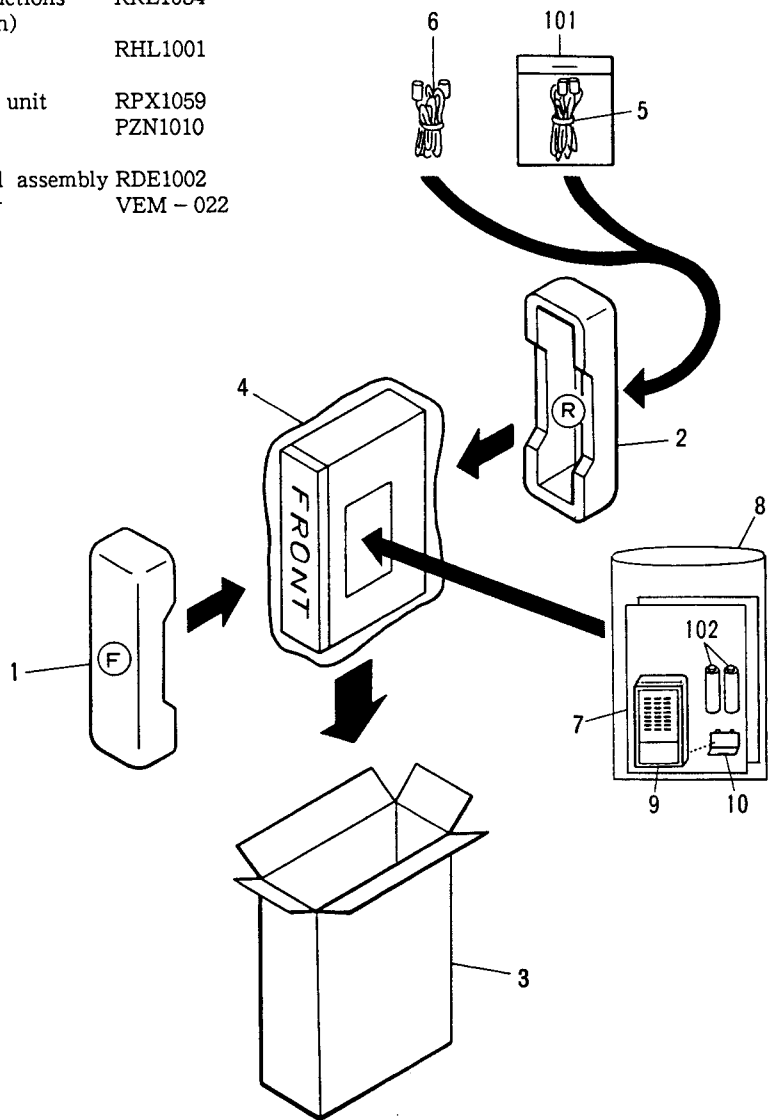

# 5. PCB CONNECTIONS DIAGRAM

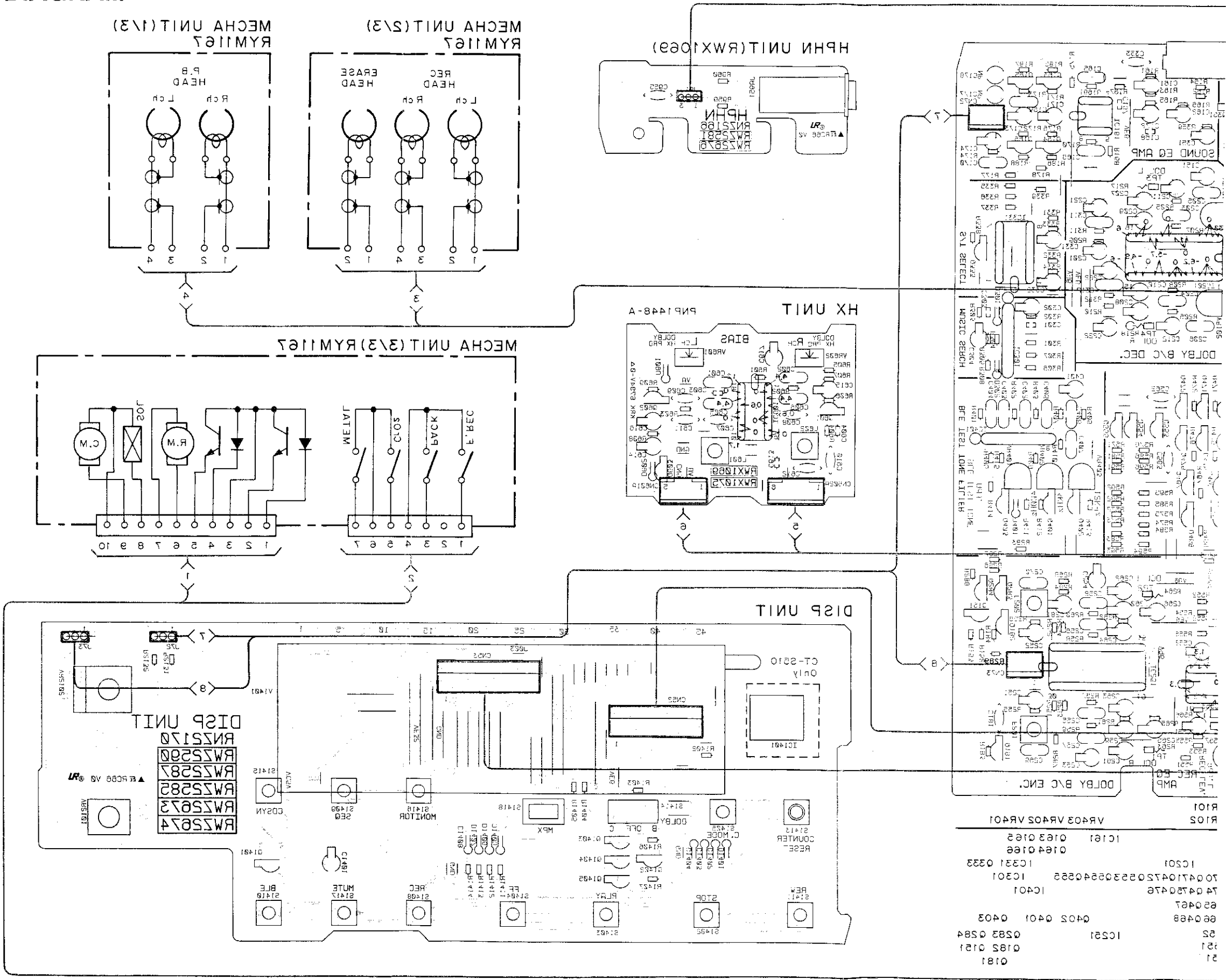

21	0181	
22	0185 0181	IC521
23	0583 0584	
24	0405 0401 0403	
25	0405 0401 0403	
26	0405 0401 0403	
27	0405 0401 0403	
28	0405 0401 0403	
29	0405 0401 0403	
30	0405 0401 0403	
31	0405 0401 0403	
32	0405 0401 0403	
33	0405 0401 0403	
34	0405 0401 0403	
35	0405 0401 0403	
36	0405 0401 0403	
37	0405 0401 0403	
38	0405 0401 0403	
39	0405 0401 0403	
40	0405 0401 0403	
41	0405 0401 0403	
42	0405 0401 0403	
43	0405 0401 0403	
44	0405 0401 0403	
45	0405 0401 0403	

A  
B  
C  
D



• View from soldering side

Power Supply Section for KU Type.

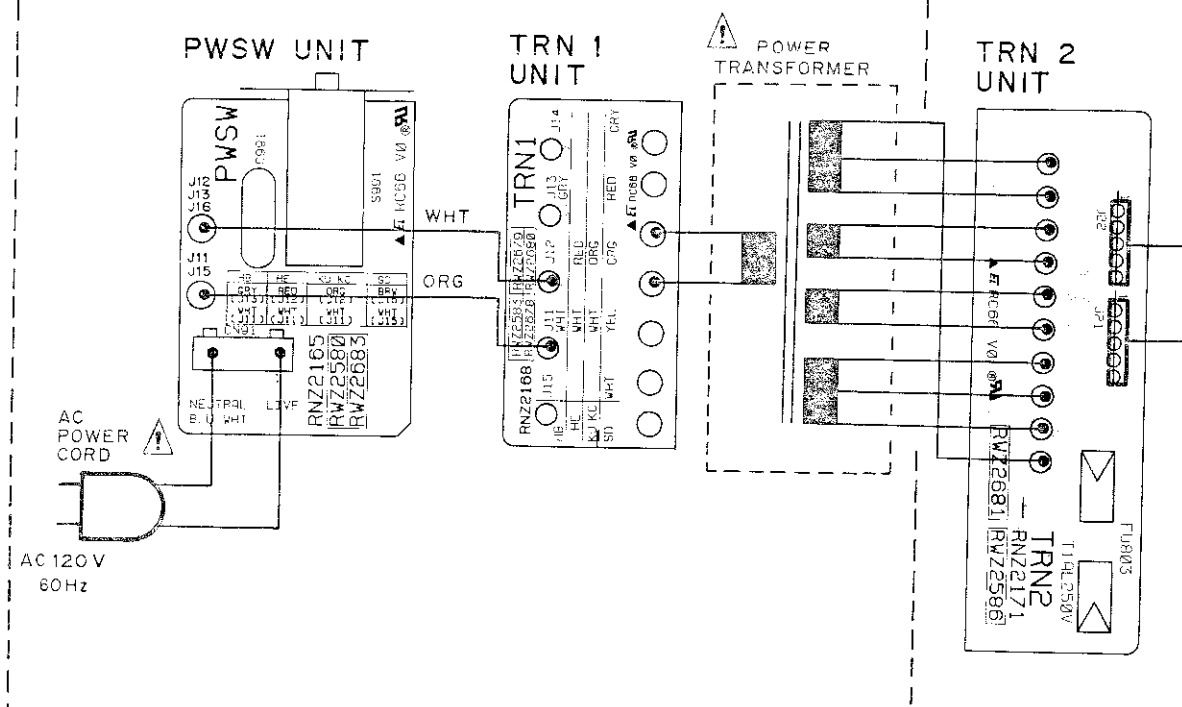

Power Supply Section for HEM and HB Types.

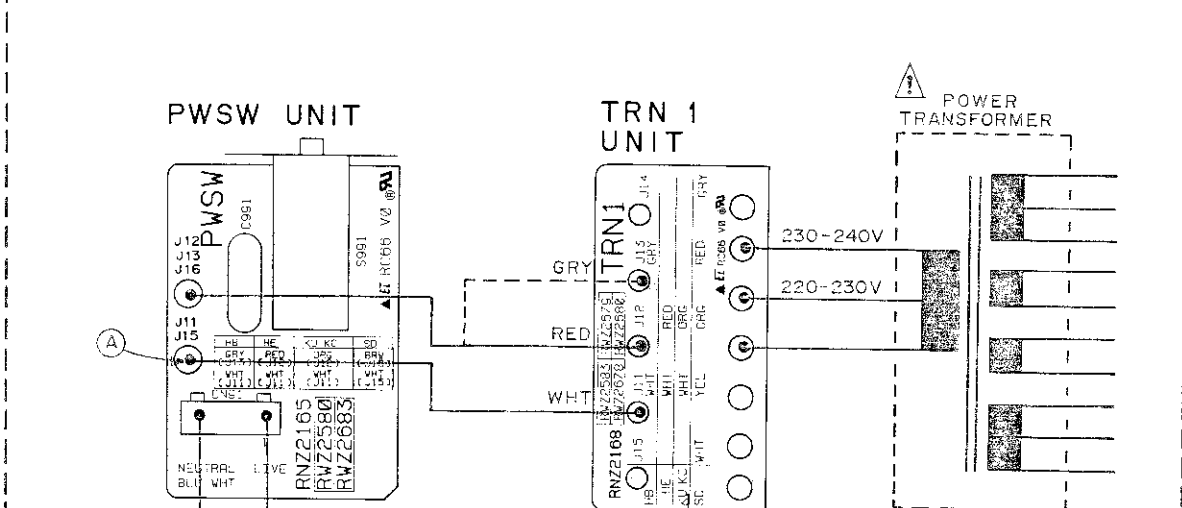

Line Voltage Selection

Line voltage can be changed with the following steps.

1. Disconnect the AC power cord.
2. Remove the top cover.
3. Change the connection wire from PWSW UNIT (Terminal No. ②) to TRN1 UNIT (Terminal No. J12 and J13) as follows.

Voltage	Terminal No. of TRN1 UNIT
220-230V	J 1 2
230-240V	J 1 3

4. Stick the line voltage label on the rear panel.

Port NO.	Description
AAX-193	220V label
AAX-192	240V label

MAIN UNIT

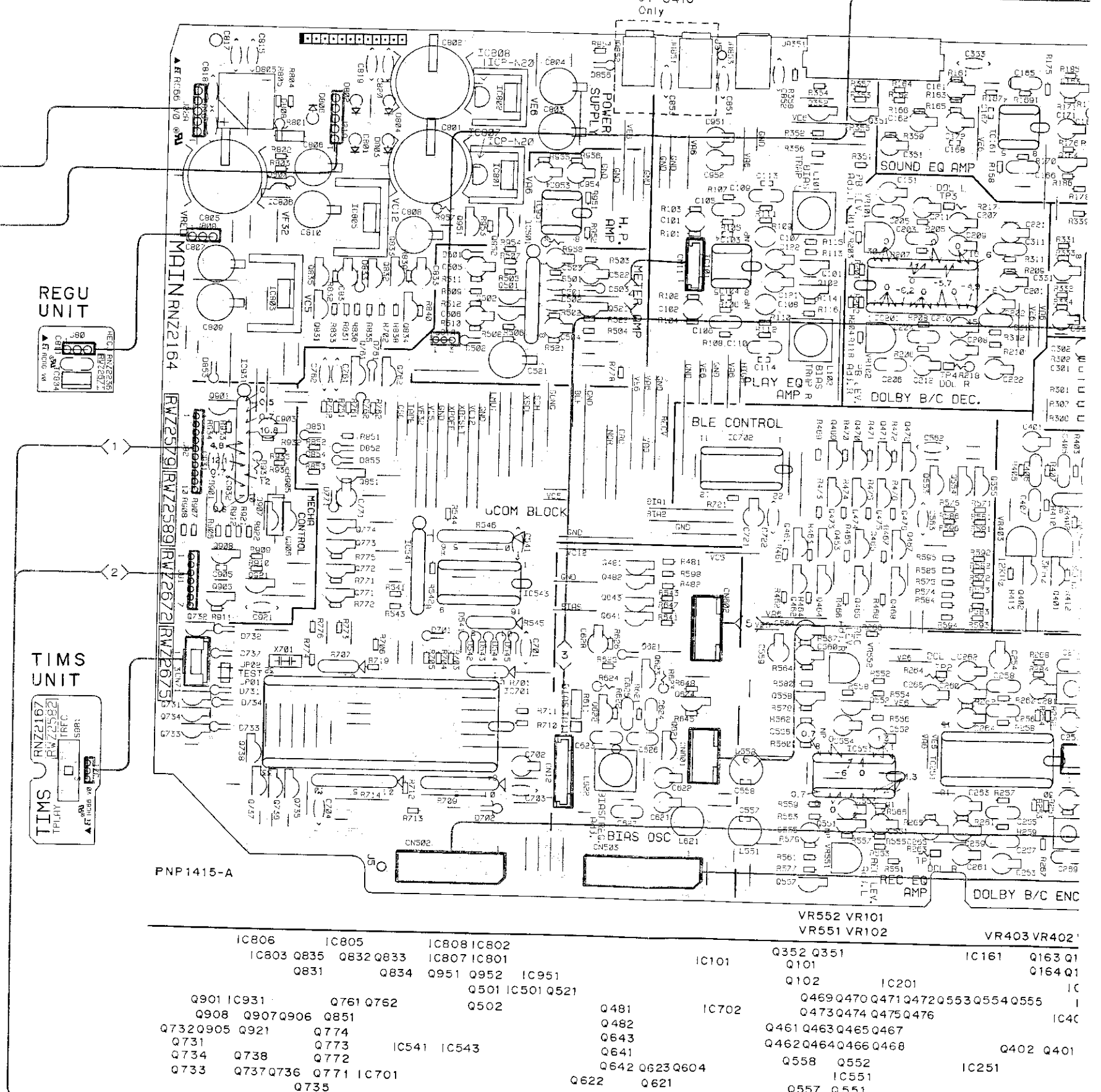

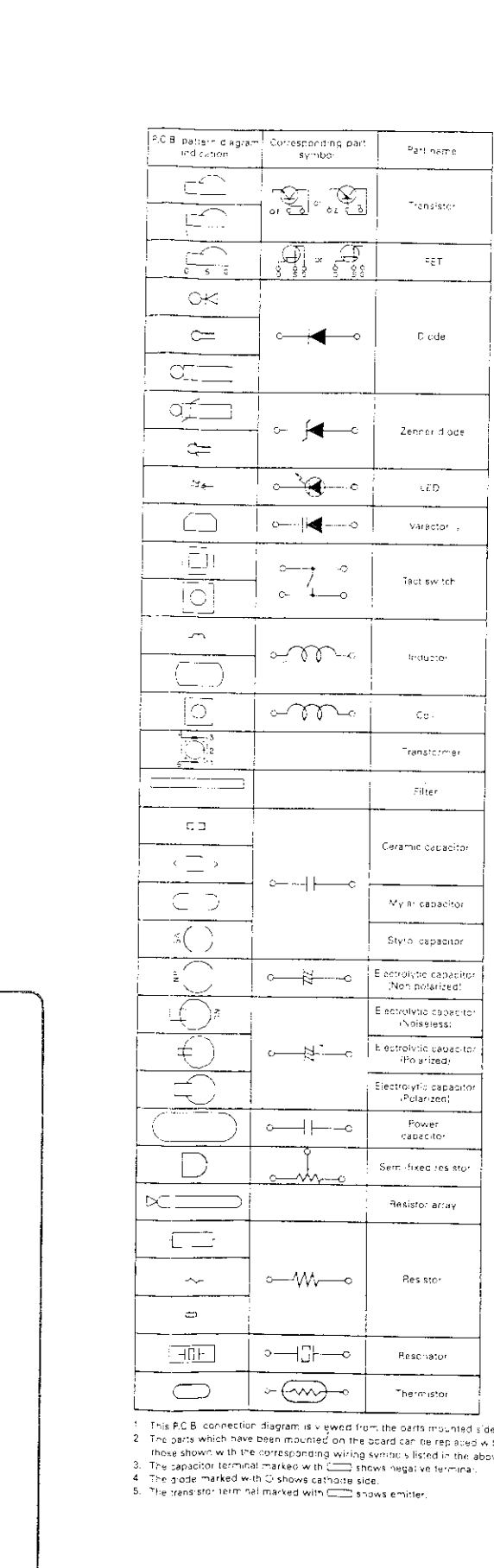
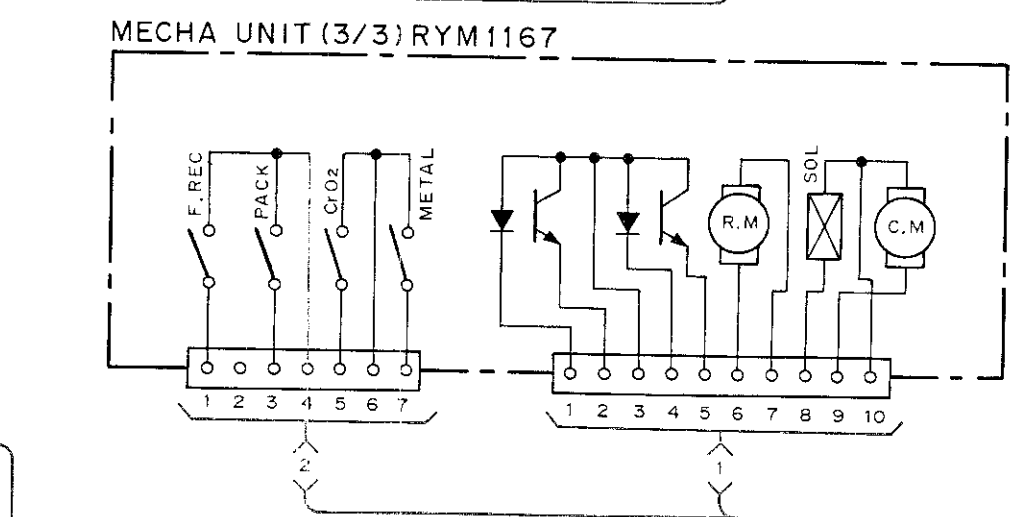
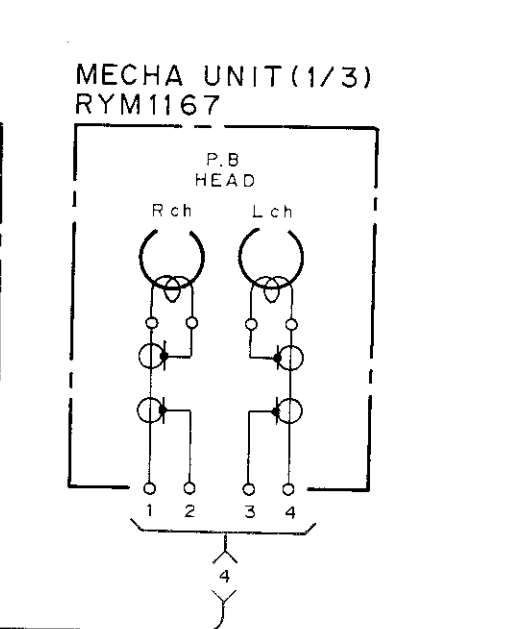
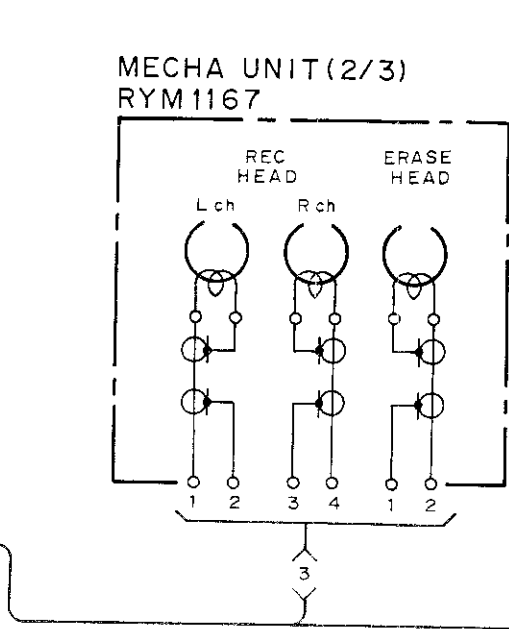
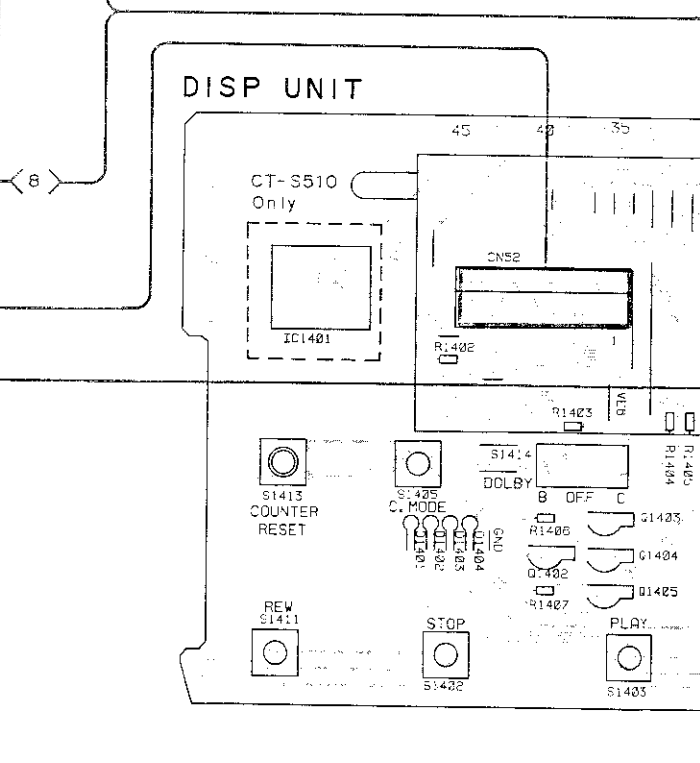
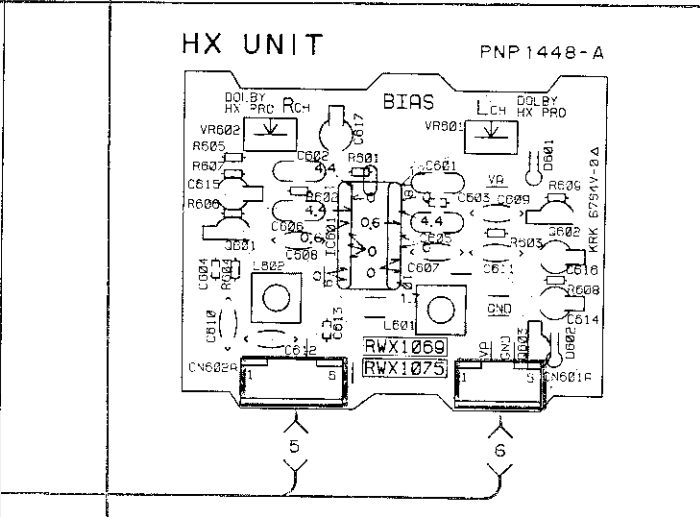
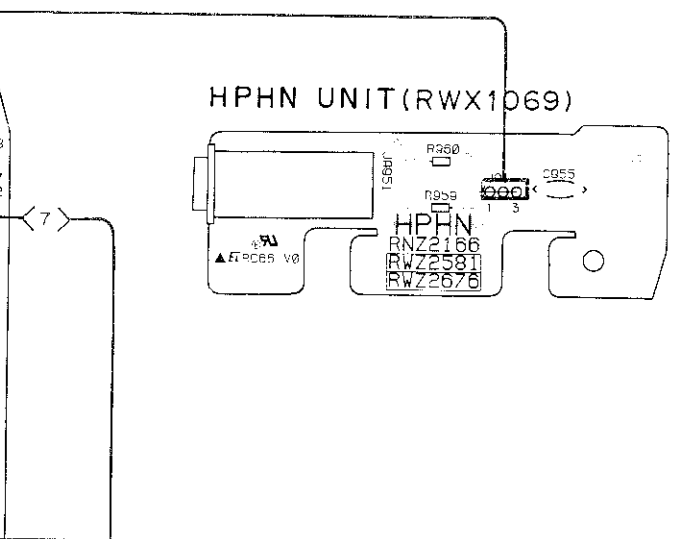
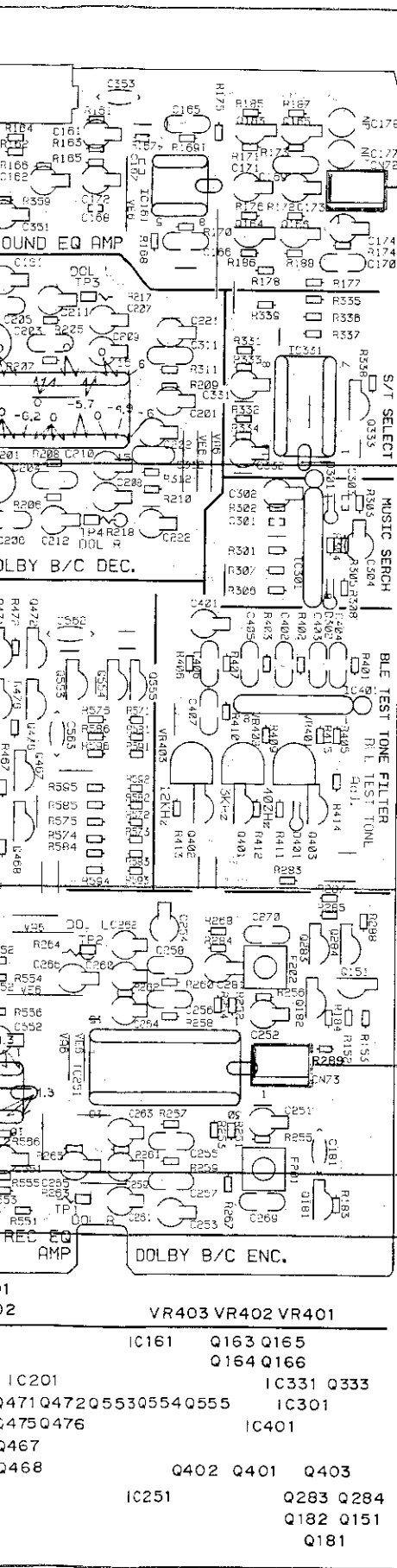

PCB pattern diagram and caption	Corresponding part symbol	Part name
		Transistor
		FET
		Diode
		Zener diode
		LED
		Varactor
		Tact switch
		Inductor
		Coil
		Transformer
		Filter
		Ceramic capacitor
		Mylar capacitor
		Styro capacitor
		Electrolytic capacitor (Non polarized)
		Electrolytic capacitor (Nonpolarized)
		Electrolytic capacitor (Polarized)
		Power capacitor
		Semi-fixed resistor
		Resistor array
		Resistor
		Reactor
		Thermistor

- This PCB connector diagram is viewed from the parts mounted side.
- The parts which have been mounted on the board can be replaced with those shown with the corresponding wiring symbols listed in the above table.
- The capacitor terminal marked with shows negative terminal.
- The diode marked with shows cathode side.
- The transistor terminal marked with shows emitter.

A  
B  
C  
D

# 6. SCHEMATIC DIAGRAM

NOTE  
If the parts are not identified in the diagram, the followings are used.

- 2SC3311A
- 2SA1309A
- 15S254

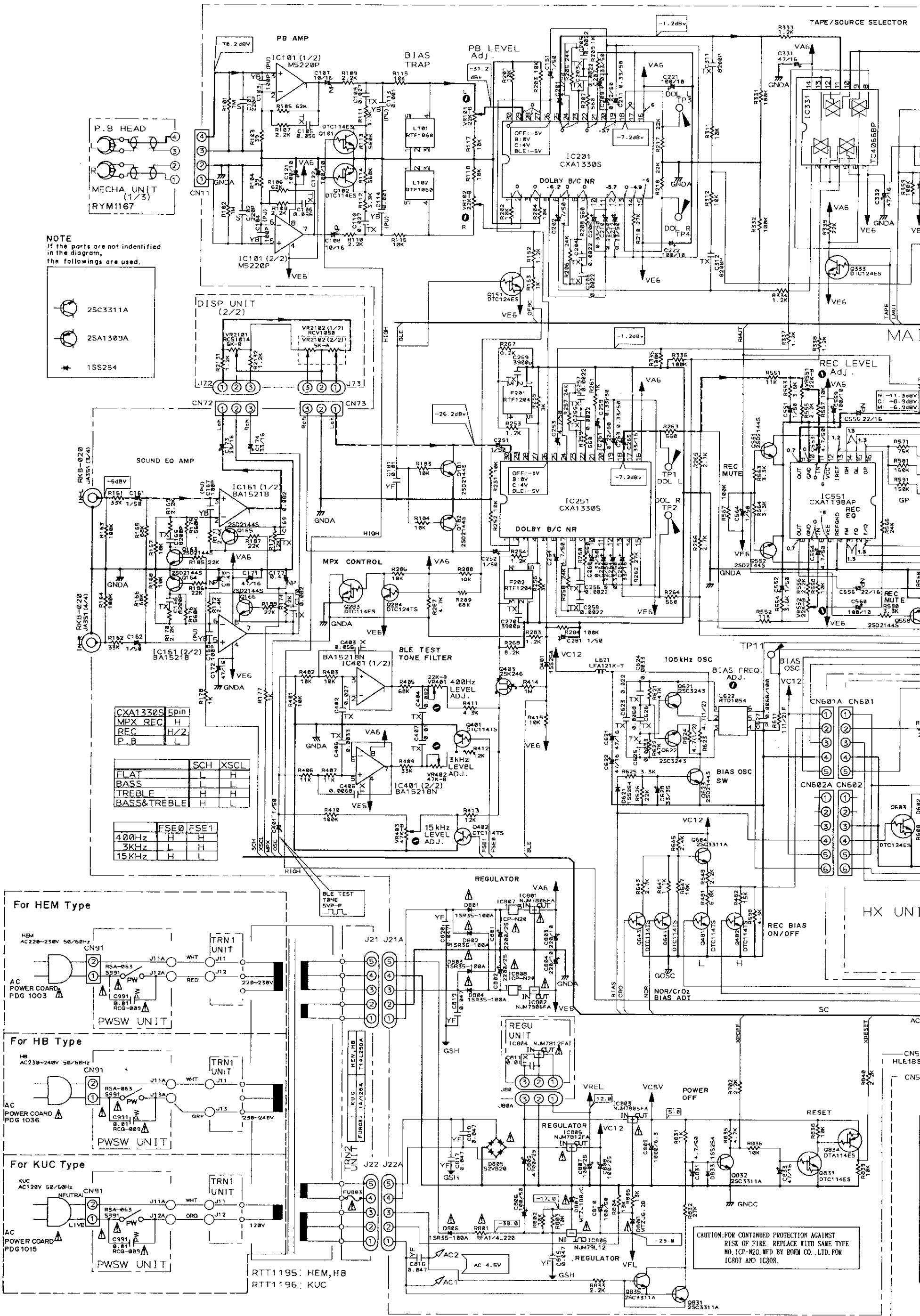

CXA1330S	5pin
MPX REC	H/H
REC	H/H
P. B	L/L

	SCH	XSC1
FLAT	L	H
BASS	L	H
TREBLE	L	H
BASS&TREBLE	H	L

  

	FSE0	FSE1
400Hz	H	H
3KHz	L	H
15KHz	H	L

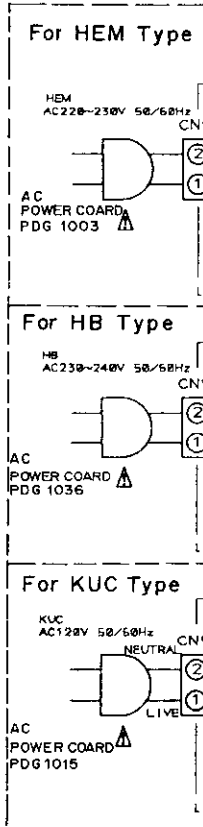

CAUTION: FOR CONTINUED PROTECTION AGAINST RISK OF FIRE, REPLACE WITH SAME TYPE NO. ICP-N20, MFD BY ROHM CO., LTD. FOR IC807 AND IC808.



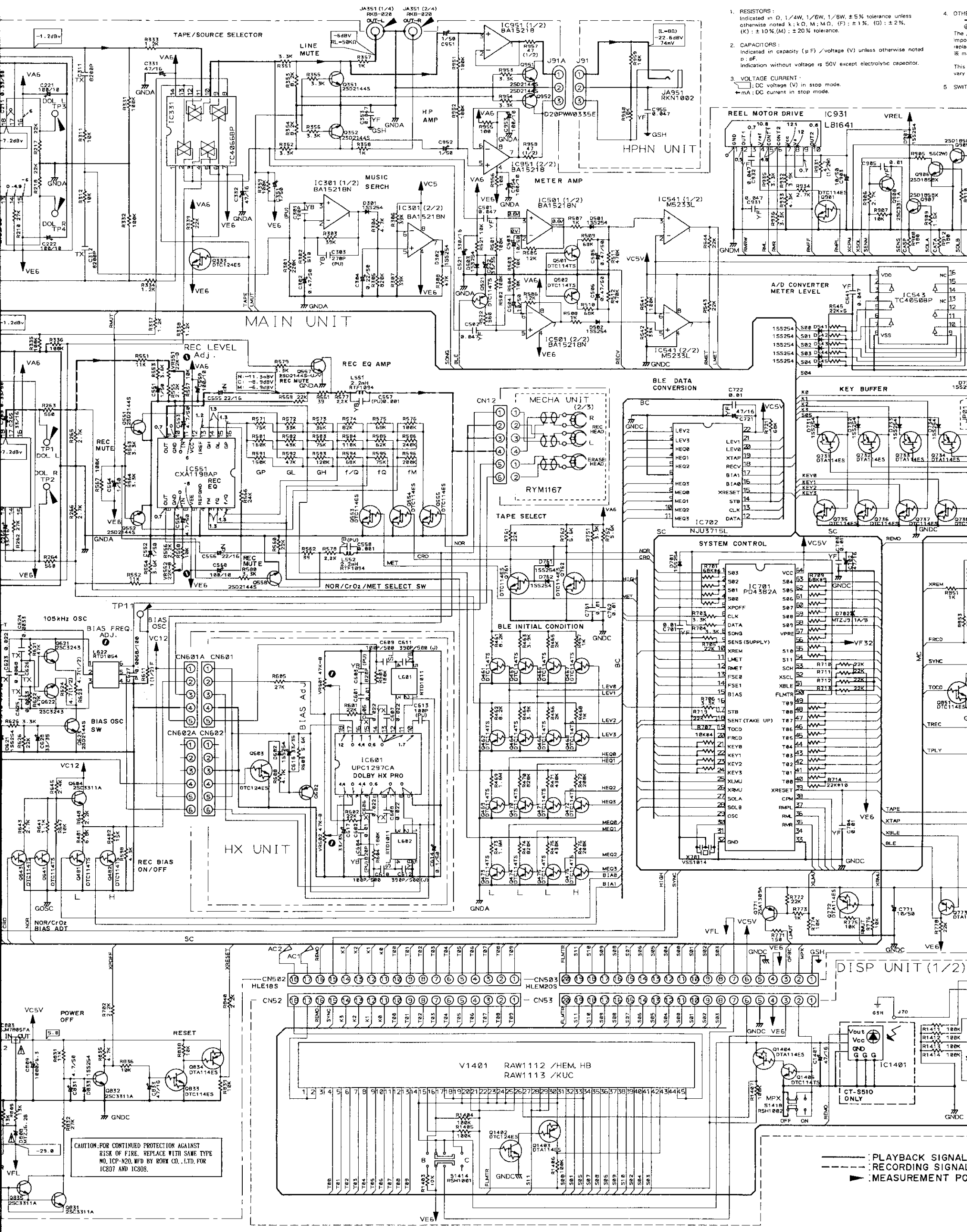

- RESISTORS:  
Indicated in Ω, 1/4W, 1/8W, 1/2W, ±5% tolerance unless otherwise noted K; M; M.O. (F); ±1%. (G); ±2%. (K); ±10%; (M); ±20% tolerance.
- CAPACITORS:  
Indicated in capacity (μF) / voltage (V) unless otherwise noted p; nF. Indication without voltage is 50V except electrolytic capacitor.
- VOLTAGE CURRENT:  
V: DC voltage (V) in stop mode.  
mA: DC current in stop mode.

CAUTION: FOR CONTINUED PROTECTION AGAINST RISE OF FIRE, REPLACE WITH SAME TYPE NO. ICP-N20, MFD BY ROHM CO., LTD. FOR IC807 AND IC808.

---: PLAYBACK SIGNAL  
- - - -: RECORDING SIGNAL  
▶: MEASUREMENT POINT



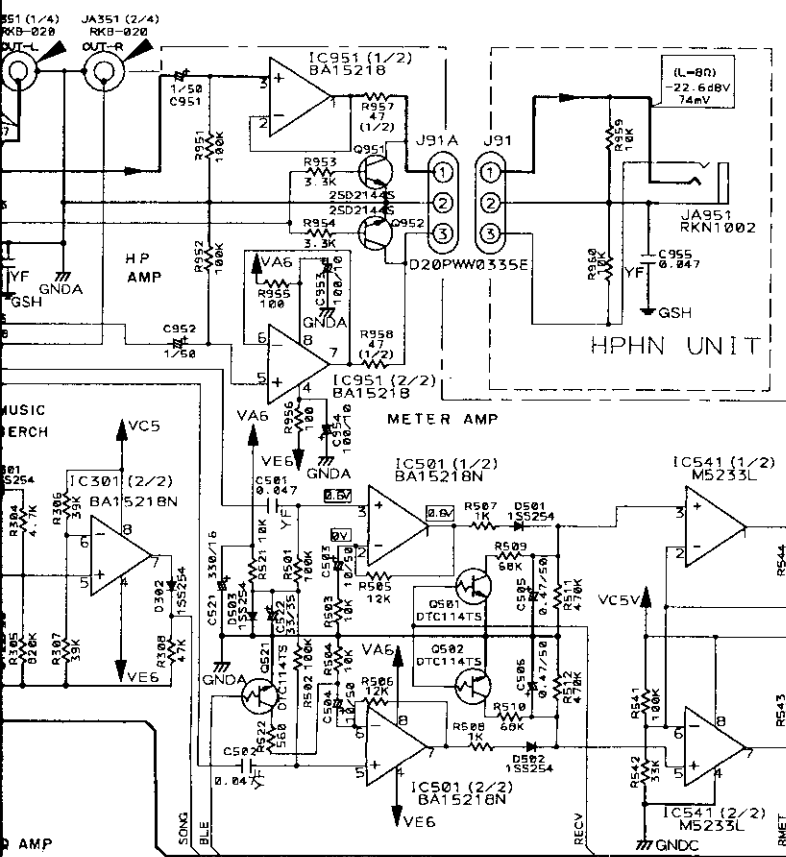

- RESISTORS:**  
Indicated in  $\Omega$ , 1/4W, 1/8W, 1/2W, 1W, 5% tolerance unless otherwise noted k; k $\Omega$ , M; M $\Omega$ , D; D $\Omega$ , F; F $\Omega$ ,  $\pm 1\%$ , (G);  $\pm 2\%$ , (K);  $\pm 10\%$ , (M);  $\pm 20\%$  tolerance.
- CAPACITORS:**  
Indicated in capacity ( $\mu$ F) / voltage (V) unless otherwise noted p; pF  
Indication without voltage is 50V except electrolytic capacitor.
- VOLTAGE CURRENT:**  
—: DC voltage (V) in stop mode.  
—m: DC current in stop mode.
- OTHERS:**  
—: Signal route  
—: Adjusting point  
The  $\Delta$  mark found on some component parts indicates the importance of the safety factor of the part. Therefore, when replacing, be sure to use parts of identical designation.  
\* marked capacitors and resistors have parts numbers.  
This is the basic schematic diagram, but the actual circuit may vary due to improvements in design.
- SWITCHES** (The underlined indicates the switch position)

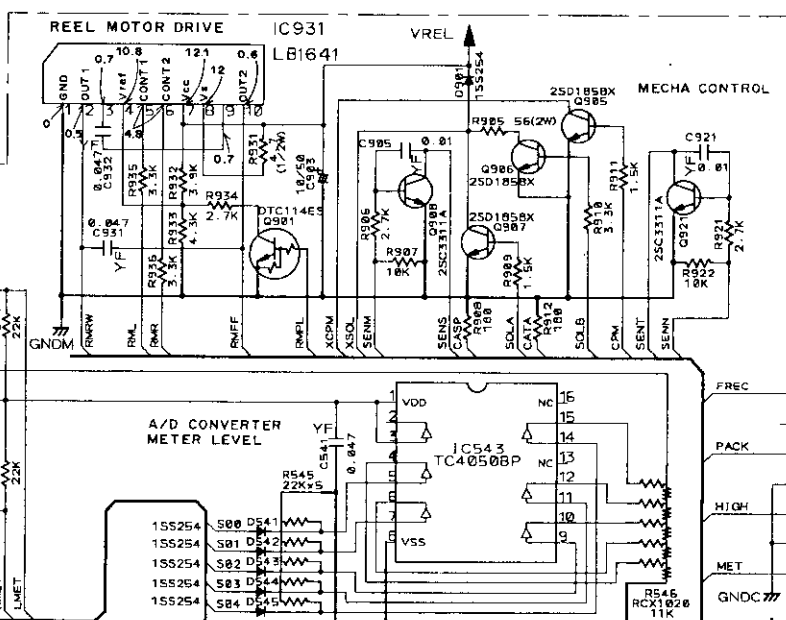

- TIMS UNIT  
S981: REC-OFF-PLAY
- PWSW UNIT  
S991: ON-OFF
- DSP UNIT  
S1402: STOP  
S1403: C. MODE  
S1404: FF  
S1405: C. MODE  
S1408: REC  
S1409: SEO  
S1410: BLE  
S1411: REW  
S1413: RESET  
S1414: DOLBY B-OFF-C  
S1415: CD SYNCRO  
S1416: MONITOR  
S1417: MUTE  
S1418: MPX ON-OFF

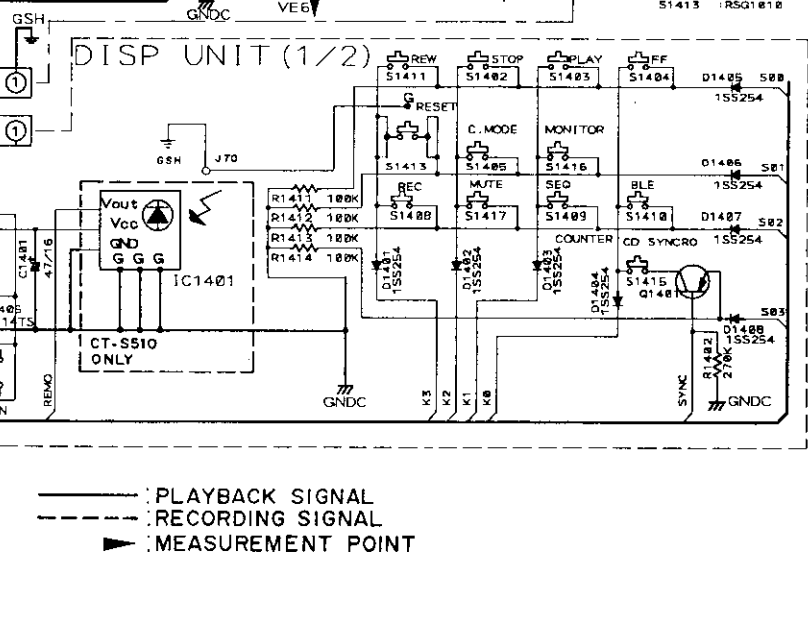
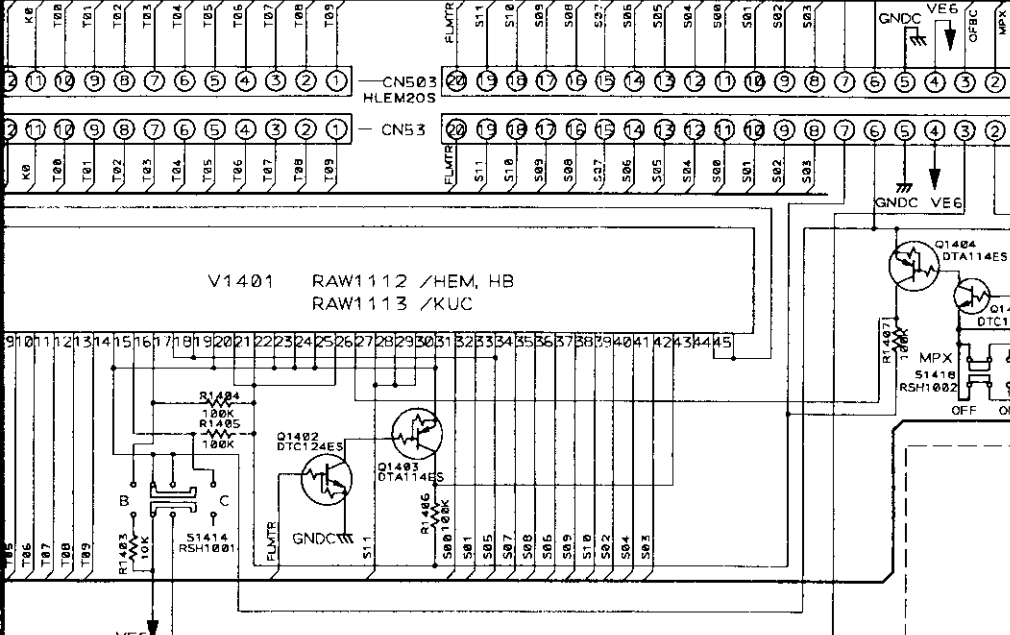
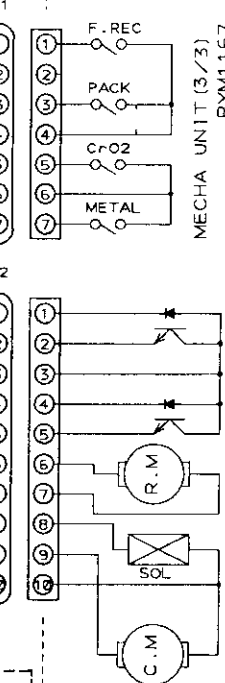
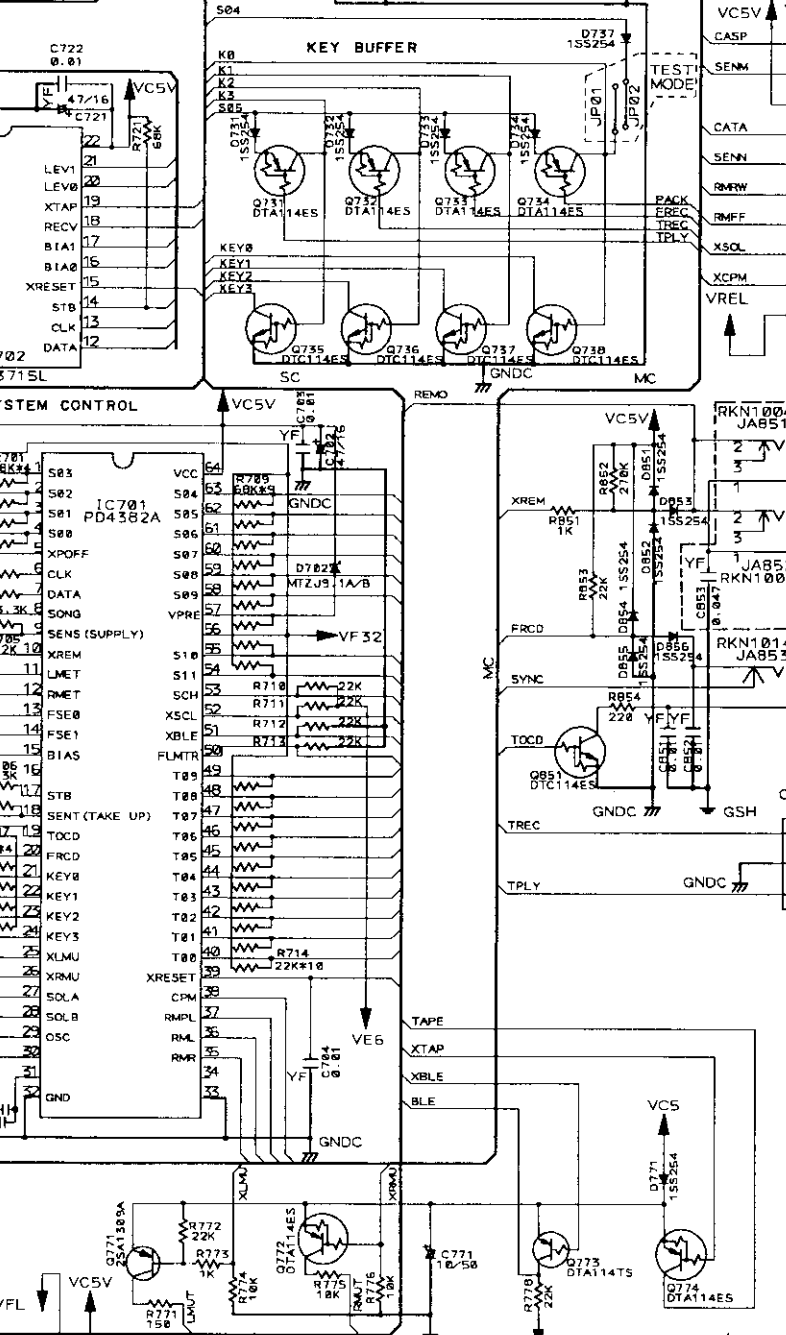
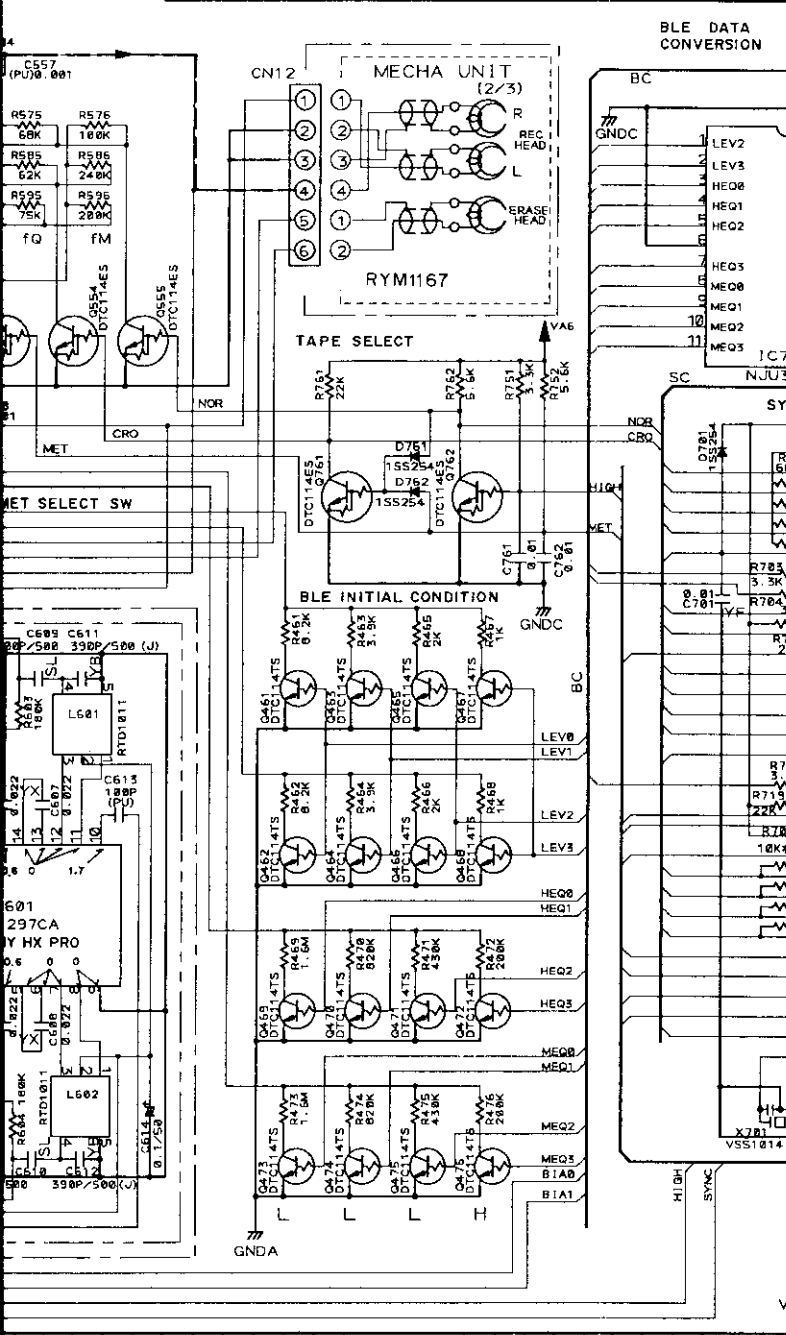

—: PLAYBACK SIGNAL  
- - -: RECORDING SIGNAL  
▲: MEASUREMENT POINT

A  
B  
C  
D  
E  
F

## 7. PCB PARTS LIST

### NOTES:

- Parts marked by "NSP" are generally unavailable because they are not in our Master Spare Parts List.
- Parts marked by "⊙" are not always kept in stock. Their delivery time may be longer than usual or they may be unavailable.
- The  $\Delta$  mark found on some component parts indicates the importance of the safety factor of the part. Therefore, when replacing, be sure to use parts of identical designation.

• When ordering resistors, first convert resistance values into code form as shown in the following examples.

- Ex.1 When there are 2 effective digits (any digit apart from 0), such as 560 ohm and 47k ohm (tolerance is shown by J=5%, and K=10%)
- 560  $\Omega$   $\rightarrow$  56  $\times$  10<sup>1</sup>  $\rightarrow$  561 ..... RD1/4PS  $\begin{matrix} 5 & 6 & 1 \\ \hline & & J \end{matrix}$
- 47k  $\Omega$   $\rightarrow$  47  $\times$  10<sup>3</sup>  $\rightarrow$  473 ..... RD1/4PS  $\begin{matrix} 4 & 7 & 3 \\ \hline & & J \end{matrix}$
- 0.5  $\Omega$   $\rightarrow$  0R5 ..... RN2H  $\begin{matrix} 0 & R & 5 \\ \hline & & K \end{matrix}$
- 1  $\Omega$   $\rightarrow$  010 ..... RS1P  $\begin{matrix} 0 & 1 & 0 \\ \hline & & K \end{matrix}$
- Ex.2 When there are 3 effective digits (such as in high precision metal film resistors).
- 5.62k  $\Omega$   $\rightarrow$  562  $\times$  10<sup>1</sup>  $\rightarrow$  5621 ..... RN1/4SR  $\begin{matrix} 5 & 6 & 2 & 1 \\ \hline & & & F \end{matrix}$

Mark	No.	Description	Part No.
<b>LIST OF ASSEMBLIES</b>			
⊙		MOTHER UNIT	RWM1498
NSP		—PWSW UNIT	RWZ2580
NSP		—HPHN UNIT	RWZ2581
NSP		—TIMS UNIT	RWZ2582
NSP		—TRN 2 UNIT	RWZ2586
NSP		—TRN 1 UNIT	RWZ2678
NSP		—MAIN UNIT	RWZ2589
⊙		—HX UNIT	RWX1069
NSP		—DISP UNIT	RWZ2590
NSP		—REGU UNIT	RWZ2671
<b>HX UNIT</b>			
<b>SEMICONDUCTORS</b>			
		IC601 DOLBY HX PRO IC	UPC1297CA
		Q602 TRANSISTOR	2SA1309A
		Q603 TRANSISTOR	DTC124ES
		D602 DIODE	1SS254
<b>COILS/TRANSFORMERS</b>			
		L601, 602	RTD1011
<b>CAPACITORS</b>			
		C601, 602 AUDIO FILM CAPACITOR	CFTXA103J50
		C603, 604 AXIAL CAPACITOR	CKPUYB821K50
		C605, 606 AUDIO FILM CAPACITOR	CFTXA223J50
		C607, 608 CERAMIC CAPACITOR	CGCYX223K25
		C609, 610 CERAMIC CAPACITOR	CCCSL101K500
		C611, 612 CERAMIC CAPACITOR	RCG1004
		C613 AXIAL CAPACITOR	CKPUYB101K50
		C614 ELECT. CAPACITOR	CEASR10M50
		C616, 617 ELECT. CAPACITOR	CEAS330M35
<b>RESISTORS</b>			
		R601-605 CARBONFILM RESISTOR	RD1/6PM□□□J
		R608, 609 CARBONFILM RESISTOR	RD1/6PM□□□J
		VR601, 602 VR	VRTB6HS473
<b>PWSW UNIT</b>			
<b>SWITCHES</b>			
$\Delta$		S991 SWITCH	RSA-063

Mark	No.	Description	Part No.
<b>CAPACITORS</b>			
$\Delta$		C991 CAPACITOR (CERAMIC)	RCG-009
<b>HPHN UNIT</b>			
<b>CAPACITORS</b>			
		C955 CERAMIC CAPACITOR	CKCYF473Z50
<b>RESISTORS</b>			
		R959, 960 CARBONFILM RESISTOR	RD1/6PM□□□J
<b>OTHERS</b>			
		JA951 JACK	RKN1002
<b>TIMS UNIT</b>			
<b>SWITCHES</b>			
		S981 SWITCH	RSH1014
<b>TRN 1 UNIT</b>			
There is no supply part in this unit.			
<b>TRN 2 UNIT</b>			
There is no supply part in this unit.			
<b>MAIN UNIT</b>			
<b>SEMICONDUCTORS</b>			
		IC101 OP-AMP-IC	M5220P
		IC161 OP-AMP IC	BA15218
		IC201 DOLBY B/C IC	CXA1330S
		IC251 DOLBY B/C IC	CXA1330S
		IC301 IC	BA15218N
		IC331 LOGIC IC	TC4066BP
		IC401 IC	BA15218N
		IC501 IC	BA15218N
		IC541 DUAL-COMPARATOR IC	M5233L
		IC543 CMOS LOGIC IC	TC4050BP
		IC551 REC EQUALIZER IC	CXA1198AP
		IC701 MCU	PD4382A
		IC702 LOGIC IC	NJU3715L
$\Delta$		IC801 REGULATOR IC	NJM7806FA
$\Delta$		IC802 REGULATOR IC	NJM7906FA

Mark	No.	Description	Part No.
$\Delta$		IC803 REGULATOR IC	NJM7805FA
$\Delta$		IC805 REGULATOR IC	NJM7812FA
$\Delta$		IC806 REGULATOR IC	NJM79L12A
$\Delta$		IC807, 808 IC PROTECTOR	ICP-N20
		IC931	LB1641
		IC951 OP-AMP IC	BA15218
		Q101, 102 TRANSISTOR	DTC114ES
		Q151 TRANSISTOR	DTC124ES
		Q163-166 TRANSISTOR	2SD2144S
		Q181, 182 TRANSISTOR	2SD2144S
		Q283 TRANSISTOR	DTC114ES
		Q284 TRANSISTOR	DTC124TS
		Q333 TRANSISTOR	DTC124ES
		Q351, 352 TRANSISTOR	2SD2144S
		Q401, 402 DIGITAL TRANSISTOR	DTC114TS
		Q403 N-FET	2SK246
		Q461-476 DIGITAL TRANSISTOR	DTC114TS
		Q481, 482 DIGITAL TRANSISTOR	DTC114TS
		Q501, 502 DIGITAL TRANSISTOR	DTC114TS
		Q521 DIGITAL TRANSISTOR	DTC114TS
		Q551, 552 TRANSISTOR	2SD2144S
		Q553-555 TRANSISTOR	DTC114ES
		Q557, 558 TRANSISTOR	2SD2144S
		Q604 TRANSISTOR	2SC3311A
		Q621, 622 TRANSISTOR	2SC3243
		Q623 TRANSISTOR	2SD2144S
		Q641 DIGITAL TRANSISTOR	DTC114TS
		Q643 DIGITAL TRANSISTOR	DTC114TS
		Q731-734 DIGITAL TRANSISTOR	DTA114ES
		Q735-738 TRANSISTOR	DTC114ES
		Q761, 762 TRANSISTOR	DTC114ES
		Q771 TRANSISTOR	2SA1309A
		Q772 DIGITAL TRANSISTOR	DTA114ES
		Q773 DIGITAL TRANSISTOR	DTA114TS
		Q774 DIGITAL TRANSISTOR	DTA114ES
		Q831, 832 TRANSISTOR	2SC3311A
		Q833 TRANSISTOR	DTC114ES
		Q834 DIGITAL TRANSISTOR	DTA114ES
		Q835 TRANSISTOR	2SC3311A
		Q851 TRANSISTOR	DTC114ES
		Q901 TRANSISTOR	DTC114ES
		Q905-907 TRANSISTOR	2SD1858X
		Q908 TRANSISTOR	2SC3311A
		Q921 TRANSISTOR	2SC3311A
		Q951, 952 TRANSISTOR	2SD2144S
		D301, 302 DIODE	1SS254
		D401 DIODE	1SS254
		D501-503 DIODE	1SS254
		D541-545 DIODE	1SS254
		D621 DIODE	1SS254
		D701 DIODE	1SS254
		D702 ZENER DIODE	MTZJ9. 1A
		D731-734 DIODE	1SS254
		D737 DIODE	1SS254
		D761, 762 DIODE	1SS254

Mark	No.	Description	Part No.
△	IC803	REGULATOR IC	NJM7805FA
△	IC805	REGULATOR IC	NJM7812FA
△	IC806	REGULATOR IC	NJM79L12A
△	IC807, 808	IC PROTECTOR	ICP-N20
	IC931		LB1641
	IC951	OP-AMP IC	BA15218
	Q101, 102	TRANSISTOR	DTC114ES
	Q151	TRANSISTOR	DTC124ES
	Q163-166	TRANSISTOR	2SD2144S
	Q181, 182	TRANSISTOR	2SD2144S
	Q283	TRANSISTOR	DTC114ES
	Q284	TRANSISTOR	DTC124TS
	Q333	TRANSISTOR	DTC124ES
	Q351, 352	TRANSISTOR	2SD2144S
	Q401, 402	DIGITAL TRANSISTOR	DTC114TS
	Q403	N-FET	2SK246
	Q461-476	DIGITAL TRANSISTOR	DTC114TS
	Q481, 482	DIGITAL TRANSISTOR	DTC114TS
	Q501, 502	DIGITAL TRANSISTOR	DTC114TS
	Q521	DIGITAL TRANSISTOR	DTC114TS
	Q551, 552	TRANSISTOR	2SD2144S
	Q553-555	TRANSISTOR	DTC114ES
	Q557, 558	TRANSISTOR	2SD2144S
	Q604	TRANSISTOR	2SC3311A
	Q621, 622	TRANSISTOR	2SC3243
	Q623	TRANSISTOR	2SD2144S
	Q641	DIGITAL TRANSISTOR	DTC114TS
	Q643	DIGITAL TRANSISTOR	DTC114TS
	Q731-734	DIGITAL TRANSISTOR	DTA114ES
	Q735-738	TRANSISTOR	DTC114ES
	Q761, 762	TRANSISTOR	DTC114ES
	Q771	TRANSISTOR	2SA1309A
	Q772	DIGITAL TRANSISTOR	DTA114ES
	Q773	DIGITAL TRANSISTOR	DTA114TS
	Q774	DIGITAL TRANSISTOR	DTA114ES
	Q831, 832	TRANSISTOR	2SC3311A
	Q833	TRANSISTOR	DTC114ES
	Q834	DIGITAL TRANSISTOR	DTA114ES
	Q835	TRANSISTOR	2SC3311A
	Q851	TRANSISTOR	DTC114ES
	Q901	TRANSISTOR	DTC114ES
	Q905-907	TRANSISTOR	2SD1858X
	Q908	TRANSISTOR	2SC3311A
	Q921	TRANSISTOR	2SC3311A
	Q951, 952	TRANSISTOR	2SD2144S
	D301, 302	DIODE	1SS254
	D401	DIODE	1SS254
	D501-503	DIODE	1SS254
	D541-545	DIODE	1SS254
	D621	DIODE	1SS254
	D701	DIODE	1SS254
	D702	ZENER DIODE	MTZJ9, 1A
	D731-734	DIODE	1SS254
	D737	DIODE	1SS254
	D761, 762	DIODE	1SS254

Mark	No.	Description	Part No.
	D771	DIODE	1SS254
△	D801-804	DIODE	1SR35-100AVL
△	D805		S2VB20
△	D806	DIODE	1SR35-100AVL
△	D807	ZENNER DIODE	MTZJ18B
△	D808	ZENER DIODE	MTZJ6, 2B
	D833	DIODE	1SS254
	D851-856	DIODE	1SS254
	D901	DIODE	1SS254
<b>COILS/TRANSFORMERS</b>			
	L101, 102	COIL	RTF1060
	L551, 552	COIL	RTF1094
	L621	RADIAL INDUCTOR	LFA121K
	L622		RTD1054
	F201, 202	FILTER	RTF1204
<b>CAPACITORS</b>			
	C101, 102	PL. STYRENE CAPACITOR	CQSA221J50
	C103, 104	AXIAL CAPACITOR	CKPUYB101K50
	C105, 106	AUDIO FILM CAPACITOR	CFTXA563J50
	C107, 108	ELECT. CAPACITOR	CEANP100M16
	C109, 110	AUDIO FILM CAPACITOR	CFTXA273J50
	C113, 114	CERAMIC CAPACITOR	CKPUYB102K50
	C121, 122	ELECT. CAPACITOR	CEAS101M10
	C151	ELECT. CAPACITOR	CEAS010M50
	C161, 162	ELECTR. CAPACITOR	CEYA010M50
	C165, 166	AUDIO FILM CAPACITOR	CFTXA822J50
	C167, 168	AXIAL CAPACITOR	CKPUYB101K50
	C169, 170	AUDIO FILM CAPACITOR	CFTXA823J50
	C171, 172	ELECT. CAPACITOR	CEAS470M16
	C173, 174	ELECTR. CAPACITOR	CEYA330M16
	C177, 178	ELECT. CAPACITOR	CEANPR47M50
	C181	CERAMIC CAPACITOR	CKCYF103Z50
	C201, 202	ELECTR. CAPACITOR	CEYA4R7M50
	C203-206	AUDIO FILM CAPACITOR	CFTXA222J50
	C207, 208	ELECT. CAPACITOR	CEASR33M50
	C209, 210	ELECT. CAPACITOR	CEASR22M50
	C211, 212	ELECT. CAPACITOR	CEASR33M50
	C221, 222	ELECT. CAPACITOR	CEAS101M10
	C251, 252	ELECTR. CAPACITOR	CEYA010M50
	C253, 254	ELECTR. CAPACITOR	CEYA4R7M50
	C255-258	AUDIO FILM CAPACITOR	CFTXA222J50
	C259, 260	ELECT. CAPACITOR	CEASR33M50
	C261, 262	ELECT. CAPACITOR	CEASR22M50
	C263, 264	ELECT. CAPACITOR	CEASR33M50
	C265, 266	ELECTR. CAPACITOR	CEYA330M16
	C269, 270	AUDIO FILM CAPACITOR	CFTXA392J50
	C281	ELECT. CAPACITOR	CEAS010M50
	C301	AXIAL CAPACITOR	CKPUYB101K50
	C302	ELECT. CAPACITOR	CEASR47M50
	C303	AXIAL CAPACITOR	CKPUYB271K50
	C304	ELECT. CAPACITOR	CEASR22M50
	C311, 312	AUDIO FILM CAPACITOR	CFTXA822J50
	C331, 332	ELECT. CAPACITOR	CEAS470M16
	C351	ELECT. CAPACITOR	CEAS010M50
	C353	CERAMIC CAPACITOR	CKCYF473Z50
	C401	ELECT. CAPACITOR	CEAS010M50

Mark	No.	Description	Part No.
	C402	AUDIO FILM CAPACITOR	CFTXA273J50
	C403	AUDIO FILM CAPACITOR	CFTXA563J50
	C404	AUDIO FILM CAPACITOR	CFTXA823J50
	C405	AUDIO FILM CAPACITOR	CFTXA332J50
	C406	AUDIO FILM CAPACITOR	CFTXA682J50
	C407	AUDIO FILM CAPACITOR	CFTXA103J50
	C501, 502	CERAMIC CAPACITOR	CKCYF473Z50
	C503, 504	ELECT. CAPACITOR	CEAS100M50
	C505, 506	ELECT. CAPACITOR	CEASR47M50
	C521	ELECT. CAPACITOR	CEAS331M16
	C522	ELECT. CAPACITOR	CEAS330M35
	C541	CERAMIC CAPACITOR	CKCYF473Z50
	C551, 552	ELECT. CAPACITOR	CEAS010M50
	C553, 554	ELECTR. CAPACITOR	CEYA4R7M50
	C555, 556	ELECT. CAPACITOR	CEANP220M16
	C557, 558	CERAMIC CAPACITOR	CKPUYB102K50
	C559, 560	ELECT. CAPACITOR	CEAS101M10
	C564	ELECT. CAPACITOR	CEAS010M50
	C621, 622	ELECT. CAPACITOR	CEAS470M16
	C623	AUDIO FILM CAPACITOR	CFTXA223J50
	C624, 625	AUDIO FILM CAPACITOR	CFTXA332J50
	C626	AUDIO FILM CAPACITOR	CFTXA682J50
	C627	CAPACITOR	CQP682J100
	C628	ELECT. CAPACITOR	CEAS330M35
	C701	CERAMIC CAPACITOR	CKCYF103Z50
	C702	ELECT. CAPACITOR	CEAS470M16
	C703, 704	CERAMIC CAPACITOR	CKCYF103Z50
	C721	ELECT. CAPACITOR	CEAS470M16
	C722	CERAMIC CAPACITOR	CKCYF103Z50
	C761, 762	CERAMIC CAPACITOR	CKCYF103Z50
	C771	ELECT. CAPACITOR	CEAS100M50
	C801, 802	ELECT. CAPACITOR	CENA222M25
	C803, 804	ELECT. CAPACITOR	CENA221M10
	C805	ELECT. CAPACITOR	CEAS472M25
	C806	ELECT. CAPACITOR	CEAS101M50
	C807, 808	ELECT. CAPACITOR	CEAS101M25
	C809	ELECT. CAPACITOR	CEAS102M6R3
	C810	ELECT. CAPACITOR	CEAS101M50
	C815-820	CERAMIC CAPACITOR	CKCYF473Z50
	C831	ELECT. CAPACITOR	CEAS4R7M50
	C833	ELECT. CAPACITOR	CEAS470M16
	C851, 852	CERAMIC CAPACITOR	CKCYF103Z50
	C903	ELECT. CAPACITOR	CEAS100M50
	C905	CERAMIC CAPACITOR	CKCYF103Z50
	C921	CERAMIC CAPACITOR	CKCYF103Z50
	C931, 932	CERAMIC CAPACITOR	CKCYF473Z50
	C951, 952	ELECT. CAPACITOR	CEAS010M50
	C953, 954	ELECT. CAPACITOR	CEAS101M10
<b>RESISTORS</b>			
	R101-118	CARBONFILM RESISTOR	RD1/6PM□□□J
	R152, 153	CARBONFILM RESISTOR	RD1/6PM□□□J
	R161-178	CARBONFILM RESISTOR	RD1/6PM□□□J
	R183-188	CARBONFILM RESISTOR	RD1/6PM□□□J
	R201-210	CARBONFILM RESISTOR	RD1/6PM□□□J
	R217, 218	CARBONFILM RESISTOR	RCN1023

△

Description	Part No.	Mark No.	Description	Part No.	Mark No.	Description	Part No.
DIODE	ISS254		C402 AUDIO FILM CAPACITOR	CFTXA273J50		R251-262 CARBONFILM RESISTOR	RD1/6PM□□□J
	1SR35-100AVL		C403 AUDIO FILM CAPACITOR	CFTXA563J50		R263, 264 CARBONFILM RESISTOR	RCN1024
	S2VB20		C404 AUDIO FILM CAPACITOR	CFTXA823J50		R265-268 CARBONFILM RESISTOR	RD1/6PM□□□J
DIODE	1SR35-100AVL		C405 AUDIO FILM CAPACITOR	CFTXA332J50		R283, 284 CARBONFILM RESISTOR	RD1/6PM□□□J
	MTZJ18B		C406 AUDIO FILM CAPACITOR	CFTXA682J50			
DIODE	MTZJ6. 2B		C407 AUDIO FILM CAPACITOR	CFTXA103J50		R286-289 CARBONFILM RESISTOR	RD1/6PM□□□J
DIODE	ISS254		C501, 502 CERAMIC CAPACITOR	CKCYF473Z50		R301-308 CARBONFILM RESISTOR	RD1/6PM□□□J
	ISS254		C503, 504 ELECT. CAPACITOR	CEAS100M50		R311, 312 CARBONFILM RESISTOR	RD1/6PM□□□J
	ISS254		C505, 506 ELECT. CAPACITOR	CEASR47M50		R331-339 CARBONFILM RESISTOR	RD1/6PM□□□J
FORMERS			C521 ELECT. CAPACITOR	CEAS331M16		R351-359 CARBONFILM RESISTOR	RD1/6PM□□□J
INDUCTOR	RTF1060		C522 ELECT. CAPACITOR	CEAS330M35		R401-403 CARBONFILM RESISTOR	RD1/6PM□□□J
	RTF1094		C541 CERAMIC CAPACITOR	CKCYF473Z50		R405-407 CARBONFILM RESISTOR	RD1/6PM□□□J
	LFA121K		C551, 552 ELECT. CAPACITOR	CEAS010M50		R409-415 CARBONFILM RESISTOR	RD1/6PM□□□J
	RTD1054		C553, 554 ELECT. CAPACITOR	CEYA4R7M50		R461-476 CARBONFILM RESISTOR	RD1/6PM□□□J
	RTF1204		C555, 556 ELECT. CAPACITOR	CEANP220M16		R481, 482 CARBONFILM RESISTOR	RD1/6PM□□□J
STYRENE CAPACITOR	CQSA221J50		C557, 558 CERAMIC CAPACITOR	CKPUYB102K50		R501-512 CARBONFILM RESISTOR	RD1/6PM□□□J
AL CAPACITOR	CKPUYB101K50		C559, 560 ELECT. CAPACITOR	CEAS101M10		R521, 522 CARBONFILM RESISTOR	RD1/6PM□□□J
IO FILM CAPACITOR	CFTXA563J50		C564 ELECT. CAPACITOR	CEAS010M50		R541-544 CARBONFILM RESISTOR	RD1/6PM□□□J
CT. CAPACITOR	CEANP100M16		C621, 622 ELECT. CAPACITOR	CEAS470M16		R545 RESISTOR ARRAY (22K)	RA5T□□□J
IO FILM CAPACITOR	CFTXA273J50		C623 AUDIO FILM CAPACITOR	CFTXA223J50		R546 LADDER RESISTOR	RCX1020
CERAMIC CAPACITOR	CKPUYB102K50		C624, 625 AUDIO FILM CAPACITOR	CFTXA332J50		R551-564 CARBONFILM RESISTOR	RD1/6PM□□□J
CT. CAPACITOR	CEAS101M10		C626 AUDIO FILM CAPACITOR	CFTXA682J50		R566, 567 CARBONFILM RESISTOR	RD1/6PM□□□J
CAPACITOR	CEAS010M50		C627 CAPACITOR	CQPA682J100		R571-586 CARBONFILM RESISTOR	RD1/6PM□□□J
CTR. CAPACITOR	CEYA010M50		C628 ELECT. CAPACITOR	CEAS330M35		R591-596 CARBONFILM RESISTOR	RD1/6PM□□□J
IO FILM CAPACITOR	CFTXA822J50		C701 CERAMIC CAPACITOR	CKCYF103Z50		R598 CARBONFILM RESISTOR	RD1/6PM□□□J
AL CAPACITOR	CKPUYB101K50		C702 ELECT. CAPACITOR	CEAS470M16		R611 CARBONFILM RESISTOR	RD1/2LF□□□J
IO FILM CAPACITOR	CFTXA823J50		C703, 704 CERAMIC CAPACITOR	CKCYF103Z50		R621, 622 CARBONFILM RESISTOR	RD1/6PM□□□J
CT. CAPACITOR	CEAS470M16		C721 ELECT. CAPACITOR	CEAS470M16		R623, 624 CARBONFILM RESISTOR	RCN1022
CTR. CAPACITOR	CEYA330M16		C722 CERAMIC CAPACITOR	CKCYF103Z50		R625, 626 CARBONFILM RESISTOR	RD1/6PM□□□J
CT. CAPACITOR	CEANPR47M50		C761, 762 CERAMIC CAPACITOR	CKCYF103Z50		R641 CARBONFILM RESISTOR	RD1/6PM□□□J
CAPACITOR	CKCYF103Z50		C771 ELECT. CAPACITOR	CEAS100M50		R643 CARBONFILM RESISTOR	RD1/6PM□□□J
CTR. CAPACITOR	CEYA4R7M50		C801, 802 ELECT. CAPACITOR	CENA222M25		R645 CARBONFILM RESISTOR	RD1/6PM□□□J
IO FILM CAPACITOR	CFTXA222J50		C803, 804 ELECT. CAPACITOR	CENA221M10		R647, 648 CARBONFILM RESISTOR	RD1/6PM□□□J
CT. CAPACITOR	CEASR33M50		C805 ELECT. CAPACITOR	CEAS472M25		R701 RESISTOR ARRAY (22K)	RA4T□□□J
CT. CAPACITOR	CEASR22M50		C806 ELECT. CAPACITOR	CEAS101M50		R702-706 CARBONFILM RESISTOR	RD1/6PM□□□J
CT. CAPACITOR	CEASR33M50		C807, 808 ELECT. CAPACITOR	CEAS101M25		R707 RESISTOR ARRAY (10K)	RA4T□□□J
CT. CAPACITOR	CEAS101M10		C809 ELECT. CAPACITOR	CEAS102M6R3		R709 RESISTOR ARRAY (68 K)	RA9T□□□J
CTR. CAPACITOR	CEYA010M50		C810 ELECT. CAPACITOR	CEAS101M50		R710-713 CARBONFILM RESISTOR	RD1/6PM□□□J
CTR. CAPACITOR	CEYA4R7M50		C815-820 CERAMIC CAPACITOR	CKCYF473Z50		R714 RESISTOR ARRAY (100K)	RA10T□□□J
IO FILM CAPACITOR	CFTXA222J50		C831 ELECT. CAPACITOR	CEAS4R7M50		R719 CARBONFILM RESISTOR	RD1/6PM□□□J
CT. CAPACITOR	CEASR33M50		C833 ELECT. CAPACITOR	CEAS470M16		R721 CARBONFILM RESISTOR	RD1/6PM□□□J
CT. CAPACITOR	CEASR22M50		C851, 852 CERAMIC CAPACITOR	CKCYF103Z50		R751, 752 CARBONFILM RESISTOR	RD1/6PM□□□J
CT. CAPACITOR	CEASR33M50		C903 ELECT. CAPACITOR	CEAS100M50		R761, 762 CARBONFILM RESISTOR	RD1/6PM□□□J
TR. CAPACITOR	CEYA330M16		C905 CERAMIC CAPACITOR	CKCYF103Z50		R771-776 CARBONFILM RESISTOR	RD1/6PM□□□J
IO FILM CAPACITOR	CFTXA392J50		C921 CERAMIC CAPACITOR	CKCYF103Z50		R778 CARBONFILM RESISTOR	RD1/6PM□□□J
PACITOR	CEAS010M50		C931, 932 CERAMIC CAPACITOR	CKCYF473Z50	△	R801 FUSIBLE RESISTOR	RFA1/4L□□□J
PACITOR	CKPUYB101K50		C951, 952 ELECT. CAPACITOR	CEAS010M50		R802-805 CARBONFILM RESISTOR	RD1/6PM□□□J
PACITOR	CEASR47M50		C953, 954 ELECT. CAPACITOR	CEAS101M10		R831-833 CARBONFILM RESISTOR	RD1/6PM□□□J
PACITOR	CKPUYB271K50		<b>RESISTORS</b>			R835, 836 CARBONFILM RESISTOR	RD1/6PM□□□J
PACITOR	CEASR22M50		R101-118 CARBONFILM RESISTOR	RD1/6PM□□□J		R838-840 CARBONFILM RESISTOR	RD1/6PM□□□J
FILM CAPACITOR	CFTXA822J50		R152, 153 CARBONFILM RESISTOR	RD1/6PM□□□J		R851-854 CARBONFILM RESISTOR	RD1/6PM□□□J
CAPACITOR	CEAS470M16		R161-178 CARBONFILM RESISTOR	RD1/6PM□□□J		R905 METAL OXIDE RESISTOR	RS2LMF□□□J
PACITOR	CEAS010M50		R183-188 CARBONFILM RESISTOR	RD1/6PM□□□J		R906-912 CARBONFILM RESISTOR	RD1/6PM□□□J
PACITOR	CKCYF473Z50		R201-210 CARBONFILM RESISTOR	RD1/6PM□□□J		R921, 922 CARBONFILM RESISTOR	RD1/6PM□□□J
PACITOR	CEAS010M50		R217, 218 CARBONFILM RESISTOR	RCN1023		R931 CARBONFILM RESISTOR	RCN1022
						R932-936 CARBONFILM RESISTOR	RD1/6PM□□□J

Mark	No.	Description	Part No.
	R951-956	CARBONFILM RESISTOR	RD1/6PM□□□J
	R957, 958	CARBONFILM RESISTOR	RCN1054
	VR101, 102	VR	RCP1046
	VR401	VR	RCP1046
	VR402, 403	VR	RCP1047
	VR551, 552	VR	RCP1046

**OTHERS**

CN502	CONNECTOR 18P	HLEM18S-1
CN503	CONNECTOR 20P	HLEM20S-1
JA351	JACK	RKB-020
JA853	JACK	RKN1014
X701	CERAMIC RESONATOR	VSS1014

**DISP UNIT****SEMICONDUCTORS**

Q1401	TRANSISTOR	2SA1309A
Q1402	TRANSISTOR	DTC124ES
Q1403, 1404	DIGITAL TRANSISTOR	DTA114ES
Q1405	DIGITAL TRANSISTOR	DTC114TS
D1401-1408	DIODE (4.19MHz)	1SS254

**SWITCHES**

S1402-1405	SWITCH	RSG1033
S1408-1411	SWITCH	RSG1033
S1413		RSG1010
S1414	SWITCH	RSH1001
S1415-1417	SWITCH	RSG1033
S1418	SWITCH	RSH1002

**CAPACITORS**

C1401	ELECT. CAPACITOR	CEAS470M16
-------	------------------	------------

**RESISTORS**

R1402-1407	CARBONFILM RESISTOR	RD1/6PM□□□J
R1411-1414	CARBONFILM RESISTOR	RD1/6PM□□□J
R2131, 2132	CARBONFILM RESISTOR	RD1/6PM□□□J
VR2101	VARIABLE RESISTOR	RCS1014
VR2102	VARIABLE RESISTOR	RCV1050

**OTHERS**

FL	HOLDER	RNK1499
IC1401	REMOTE SENSOR	HC-177
CN502	CONNECTOR 18P	52492-1820
CN503	CONNECTOR 20P	52492-2020
V1401	FL TUBE	RAW1112

**REGU UNIT****SEMICONDUCTORS**

△	IC804	REGULATOR IC	NJM7812FA
---	-------	--------------	-----------

**CAPACITORS**

C811	AUDIO FILM CAPACITOR	CFTXA103J50
------	----------------------	-------------

## 8. TEST MODE

### 8.1. SETTING THE TEST MODE

The test mode is set by short – circuiting jumper wires JP01 and JP02 (MAIN unit) while the mechanism is in the STOP mode. The FL counter will display "0".

### 8.2. TEST MODE OPERATIONS

When the test mode is set, the monitor switches to the SOURCE side, and the FL counter displays the "TEST NO.".

#### 1. Checking the SWs

During the test mode, light up the FL as follows according to the position of the various SWs.

To check the CD SYNCHRO key, connect a control cable between the cassette deck and compact disc player, and short – circuit the FR CD terminal (Pin 20) and TO CD terminal (Pin 19) of IC701 (CPU). When the CD SYNCHRO key is pressed in this condition, the CPU outputs a "H" level to the TO CD terminal. If a "L" level is input to the FR CD terminal at this time, the CPU determines that the communication line is operating normally.

SW or KEY Position	Display	Condition
TIMER PLAY	TREBLE	TIMER PLAY (S981) SW ON
TIMER REC	BASS	TIMER REC (S981) SW ON
F. REC	TIME	Recording is possible (Mecha unit)
PACK	REMAIN	Tape is loaded (Mecha unit)
CD SYNCHRO	CD DECK SYNCHRO	CD SYNCHRO (S1415) key ON, communication line OK

#### 2. Others

The TEST NO. is "0" immediately after the setting of the test mode. After this, it is switched as follows by the AUTO – BLE key and SOUND EQ key.

The switching of TEST NO. "1" to "3", and "4" to "7" is cyclical.

NOTE:

Refer to page 32 for details on AUTO – BLE adjustment.

TEST NO.	Input Key	FL Display	LINE MUTE	REC MUTE	BIAS	Adjusting Item and Waveform Observation
1	AUTO BLE	1	ON	ON	OFF	• 400 Hz OSC for AUTO – BLE output level adjustment
2		2	ON	ON	OFF	• 3 kHz OSC for AUTO – BLE output level adjustment
3		3	ON	ON	OFF	• 15 kHz OSC for AUTO – BLE output level adjustment
4	SOUND EQ	4	ON	OFF	ON	• BIAS sweep waveform monitor Observe the bias control terminal of the HX – PRO IC with an oscilloscope.
5		5	ON	OFF	ON	• LEVEL sweep waveform monitor Observe the REC AMP output with a millivoltmeter. The internal OSC generates 400 Hz.
6		6	ON	OFF	ON	• Mid EQ sweep waveform monitor Observe the REC AMP output with a millivoltmeter. The internal OSC generates 3 kHz.
7		7	ON	OFF	ON	• High EQ sweep waveform monitor Observe the REC AMP output with a millivoltmeter. The internal OSC generates 15 kHz.

### 8.3. RELEASING THE TEST MODE

Release the test mode by pressing the COUNTER RESET key, or turning off the power.

## 8. MODE D'ESSAI

### 8.1. REGLAGE DU MODE D'ESSAI

Le mode d'essai se règle avec les cavaliers de court – circuitage JP01 et JP02 quand le mécanisme est en mode STOP. Le compteur FL affichera "0".

### 8.2. OPERATIONS EN MODE D'ESSAI

Quand le mode d'essai est posé, le moniteur passe à SOURCE et le compteur FL affiche "TEST NO.".

### 1. Contrôle des interrupteurs

En mode d'essai, activer FL selon la position des différents interrupteurs.

Pour contrôler la touche CD SYNCHRO, raccorder un câble de contrôle entre la platique cassette et le lecteur de disque compact, et court – circuiter la borne FR CD (broche 20) et la borne TO CD (broche 19) de IC701 (CPU). Si la touche CD SYNCHRO est alors pressée, le CPU fournit le niveau "H" à la borne TO CD. Si le niveau "L" est alors entré à la borne FR CD, le CPU considère que la ligne de communication fonctionne normalement.

Position d'interrupteur/touche	Affichage	Etat
TIMER PLAY	<u>TREBLE</u>	Interrupteur TIMER PLAY (S981) sur ON
TIMER REC	<u>BASS</u>	Interrupteur TIMER REC (S981) sur ON
F. REC	TIME	Lecture possible (unité Mecha)
PACK	REMAIN	Chargement de la bande (unité Mecha)
CD SYNCHRO	CD DECK SYNCHRO	Touche CD SYNCHRO (S1415) sur ON, ligne de communication normale

### 2. Divers

Le TEST NO. est "0" immédiatement après le réglage du mode d'essai. Ensuite, il est commuté comme suit par les touches AUTO – BLE et SOUND EQ.

La commutation de TEST NO. de "1" à "3", et "4" à "7" est cyclique.

NOTE:

Voir la page 36 pour les détails du réglage de AUTO – BLE.

TEST NO.	Touche d'entrée	Affichage FL	LINE MUTE	REC MUTE	BIAS	Item à régler et observation de la forme d'onde
1	AUTO BLE	1	ON	ON	OFF	• 400 Hz OSC pour le réglage du niveau de sortie AUTO – BLE
2		2	ON	ON	OFF	• 3 kHz OSC pour le réglage du niveau de sortie AUTO – BLE
3		3	ON	ON	OFF	• 15 kHz OSC pour le réglage du niveau de sortie AUTO – BLE
4	SOUND EQ	4	ON	OFF	ON	• Moniteur d'onde en dent de scie BIAS Observer la borne de commande de polarisation du HX – PRO IC avec un oscilloscope.
5		5	ON	OFF	ON	• Moniteur d'onde en dent de scie LEVEL Observer la sortie REC AMP avec un millivoltmètre. L'OSC interne produit 400 Hz.
6		6	ON	OFF	ON	• Moniteur d'onde en dent de scie Mid EQ Observer la sortie REC AMP avec un millivoltmètre. L'OSC interne produit 3 kHz.
7		7	ON	OFF	ON	• Moniteur d'onde en dent de scie High EQ Observer la sortie REC AMP avec un millivoltmètre. L'OSC interne produit 15 kHz.

### 8.3. SORTIE DU MODE D'ESSAI

Quitter le mode d'essai en appuyant sur la touche COUNTER RESET, ou en mettant l'appareil hors tension.

## 8. MODO DE PRUEBA

### 8.1. AJUSTE DEL MODO DE PRUEBA

El modo de prueba se ajusta cortocircuitando los puentes JP01 y JP02 mientras el mecanismo se encuentra en el modo STOP. En el contador FL se visualizará "0".

### 8.2. OPERATIONS EN MODO DE PRUEBA

Cuando se ha ajustado el modo de prueba, el monitor conmuta al lado SOURCE, y en el contador FL se visualiza "TEST NO.".

### 1. Verificación de los SWs

Durante el modo de prueba, ilumine el FL según se indica a continuación de acuerdo con la posición de los distintos SWs.

Para verificar la tecla CD SYNCHRO, conecte un cable de control entre el magnetófono y el reproductor de discos compactos, y cortocircuite el terminal FR CD (Clavija 20) y el terminal TO CD (Clavija 19) de IC701 (CPU). Cuando se oprime la tecla CD SYNCHRO en esta condición, la CPU entrega un nivel "H" al terminal TO CD. Si en este momento se introduce un nivel "L" al terminal FR CD, la CPU determina que la línea de comunicación está operando normalmente.

Posición SW o de KEY	Visualización	Condición
TIMER PLAY	TREBLE	TIMER PLAY (S981) SW ON
TIMER REC	BASS	TIMER REC (S981) SW ON
F. REC	TIME	Es posible grabar (Unidad mecá.)
PACK	REMAIN	La cinta está colocada (Unidad mecá.)
CD SYNCHRO	CD DECK SYNCHRO	Tecla CD SYNCHRO (S1415) ON, línea de comunicación OK.

### 2. Otros

Inmediatamente después de ajustar el modo de prueba, el TEST NO. es "0". A continuación se conmuta, mediante la tecla AUTO - BLE y la tecla SOUND EQ, según se indica a continuación.

La conmutación de TEST NO. de "1" a "3", y de "4" a "7" es cíclica

#### NOTA:

Consulte las páginas 40 con respecto a los detalles sobre el ajuste AUTO - BLE.

TEST NO.	Tecla de Entrada	Visualización de FL	LINE MUTE	REC MUTE	BIAS	Item de ajuste y observación de forma de onda
1	AUTO BLE	1	ON	ON	OFF	• OSC de 400 Hz para ajuste del nivel de salida de AUTO - BLE.
2		2	ON	ON	OFF	• OSC de 3 kHz para ajuste del nivel de salida de AUTO - BLE.
3		3	ON	ON	OFF	• OSC de 15 kHz para ajuste del nivel de salida de AUTO - BLE.
4	SOUND EQ	4	ON	OFF	ON	• Monitor de forma de onda de barrido BIAS. Observe con un osciloscopio el terminal de control de polarización de HX - PRO IC.
5		5	ON	OFF	ON	• Monitor de la forma de onda de barrido de LEVEL. Observe con un milivoltímetro la salida de REC AMP. El OSC interno genera 400 Hz.
6		6	ON	OFF	ON	• Monitor de forma de onda de barrido EQ media. Observe con un milivoltímetro la salida REC AMP. El OSC interno genera 3 kHz.
7		7	ON	OFF	ON	• Monitor de forma de onda de barrido EQ alta. Observe con un milivoltímetro la salida de REC AMP. El OSC interno genera 15 kHz.

### 8.3. LIBERACION DEL MODO DE PRUEBA

Libere el modo de prueba oprimiendo la tecla COUNTER RESET, o interrumpiendo la alimentación.



# 9. ADJUSTMENTS

## 9.1 MECHANICAL ADJUSTMENT

1. Tape speed Adjustment			
Mode	Test tape	Adjustment position	Specification rating (playback frequency)
PLAY	Play the STD-301 tape (3kHz)	Tape speed adjustment hole	3000Hz ± 5Hz

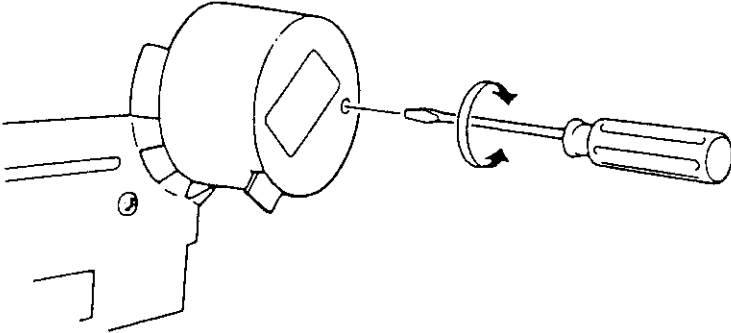
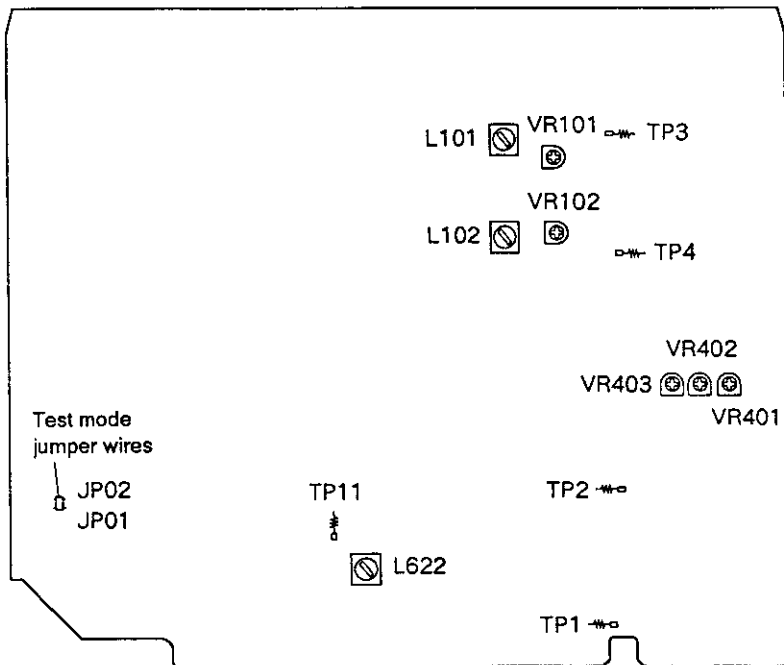

Fig. 9-1 Tape speed adjustment

### MAIN UNIT



### HX UNIT

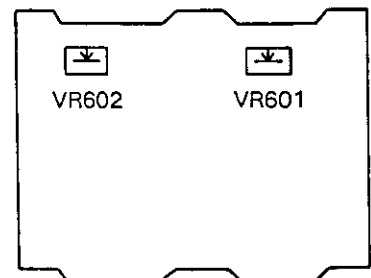

Fig. 9-2 Adjusting points

## 9.2 ELECTRICAL ADJUSTMENTS

### Adjustment Conditions

1. The mechanical adjustments must be completed first.
2. The head must be cleaned and demagnetized.
3. Turn power on allow the deck to warm up for at least a few minutes before commencing any electrical adjustments.
4. The reference signal is 0 dBV=1 Vrms.
5. Connect a 50 kΩ (or between 47k to 52 kΩ ) load resistance to the OUTPUT terminals.
6. Unless otherwise specified, the switches listed below are left in the positions indicated.

DOLBY NR : OFF  
 TAPE SELECTOR : NORM

### Test Tapes

- STD-331E : Playback adjustments  
 (See Fig. 9-3)
- STD-631 : NORMAL blank tape  
 STD-621 : CrO<sub>2</sub> blank tape  
 STD-610 : METAL blank tape

\* As the reference recording level is 250 nwb/m for STD-331E, the recording level will be higher by 4 dB for STD-331B (160 nwb/m). When adjusting, pay carefull attention to the type of tape used.

### List of Adjustments

#### Playback sections

1. Head azimuth adjustment.
2. Playback level adjustment.

#### Recording sections

1. Bias oscillator adjustment.
2. Bias trap adjustment.
3. Recording bias adjustment.
4. Recording level adjustment.
5. AUTO BLE adjustment

NOTE: This unit has an automatic tape selection feature.

*HX Pro headroom extension originated by Bang & Olufsen and manufactured under license from Dolby Laboratories Licensing Corporation. "DOLBY", the double-D symbol , and "HX PRO" are trademarks of Doldy Laboratories Licensing Corporation.*

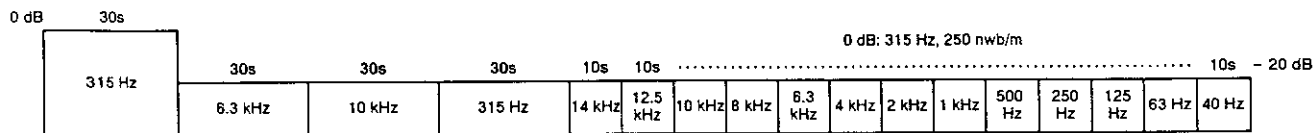

Fig. 9-3 Constants of the test tape STD-331E

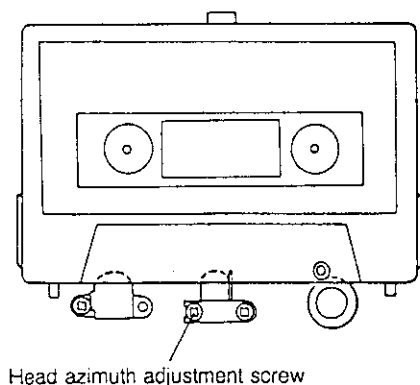

Fig. 9-4 Head azimuth adjustment

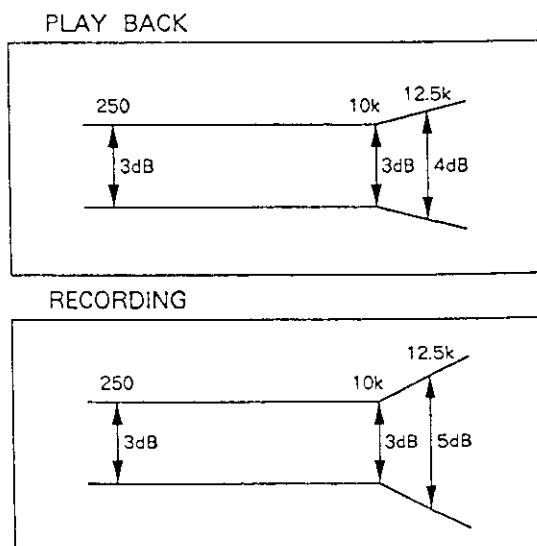

Fig. 9-5 Frequency response zone

## PLAYBACK SECTION

### 1. Head Azimuth Adjustment

- Turn VR101, 102 to mechanical center positions.

No.	Mode	Input signal & test tape	Adjustment location	Measuring location	Adjustment value	Remarks
1.	PLAY	Play the 10 kHz/-20 dB section of STD-331E test tape.	Head azimuth adjustment screw. (See Fig. 9-4)	LINE OUT	Maximum playback signal level.	
2.	STOP	Lock the screw with screw lock after completing adjustment.				

### 2. Playback Level Adjustment

- This adjustment determines the DOLBY NR level, and must be performed with great care.

No.	Mode	Input signal & test tape	Adjustment location	Measuring location	Adjustment value	Remarks
1.	PLAY	Play the 315 Hz/0 dB section of the STD-331E test tape.	Deck VR101 (Lch) VR102 (Rch)	TP. 3 (Lch) TP. 4 (Rch)	-8.7 dBV	This adjustment must be performed accurately for proper Dolby lever setting.

## RECORDING SECTION

### 1. Bias Oscillator Adjustment

No.	Mode	Input signal & test tape	Adjustment location	Measuring location	Adjustment value	Remarks
1.	REC	Load the STD-810 test tape with no input signal.	Deck L822	TP. 11	105 kHz $\pm$ 0.3 kHz	

### 2. Bias Trap Adjustment

No.	Mode	Input signal & test tape	Adjustment location	Measuring location	Adjustment value	Remarks
1.	REC	Load the STD-810 test tape with no input signal.	Deck L101 (Lch) L102 (Rch)	LINE OUT	Minimum output	

### 3. Recording Bias Adjustment

- After the adjustment, caution should be exercised so as not to become under bias by checking the distortion rate.

No.	Mode	Input signal & test tape	Adjustment location	Measuring location	Adjustment value	Remarks
1.	REC	Load the STD-831 test tape. Record the 315 Hz and 10 kHz signals at -20 dBV input level and playback.	Deck VR801 (Lch) VR802 (Rch)	LINE OUT	Repeatedly record, playback and adjust so that the playback level of 10 kHz signal becomes 0 dB $\pm$ 0.5 dB when compared with the 315 Hz signal.	

**4. Recording Level Adjustment**

No.	Mode	Input signal & test tape	Adjustment location		Measuring location	Adjustment value	Remarks
1.	REC/ PAUSE	Apply a 315 Hz/ - 4dB signal to the line input terminals, load the STD-831 test tape.	REC level control volume		TP. 1 (Lch) TP. 2 (Rch)	-11.2 dBV	
2.	REC/ PLAY	Record the above signal onto the STD-831 test tape, and playback.	Deck	VR601 (Lch) VR602 (Rch)	TP. 3 (Lch) TP. 4 (Rch)	Repeatedly record, playback and adjust so that the playback signal level becomes -11.2 dBV.	
3.	REC/ PLAY	Record the above signal onto the STD-821 test tape, and playback.	Check		TP. 3 (Lch) TP. 4 (Rch)	-11.2 dBV ± 1.5 dB	
4.	REC/ PLAY	Record the above signal onto the STD-810 test tape, and playback.	Check		TP. 3 (Lch) TP. 4 (Rch)	-11.2 dBV ± 1.5 dB	

**5. AUTO BLE Adjustment**

- BLE adjustment should be performed after all other adjustments are completed.
- This adjustment should be performed in the test mode.
- As to setting up the test mode, refer to page 26.

No.	Mode	Input signal & test tape	Adjustment location	Measuring location	Adjustment value	Remarks
1.		Set to test mode.	-	-	-	
2.		Press the AUTO BLE key on the front panel.	Level meter Rch	VR401	Adjust so that - 3 dB on the level meter flashes.	400 Hz adjustment (FL indication 1) (TEST MODE 1)
3.		Press the AUTO BLE key on the front panel.		VR402	Adjust so that - 3 dB on the level meter flashes.	3 kHz adjustment (FL indication 2) (TEST MODE 2)
4.		Press the AUTO BLE key on the front panel.		VR403	Adjust so that - 3 dB on the level meter flashes.	15 kHz adjustment (FL indication 3) (TEST MODE 3)

# 9. REGLAGES

## 9.1 RÉGLAGES MECANIQUE

1. Réglage de la vitesse de défilement de la bande			
Mode	Bande d'étalonnage	Position de réglage	Spécifications nominales (fréquence de lecture)
LECTURE	Lire la bande STD-301 (3kHz)	Trou de réglage de vitesse de bande	3000Hz + 5Hz

The diagram shows a mechanical component with a circular face. A screwdriver is shown adjusting a screw located in a hole on the right side of the component. Two curved arrows indicate the direction of rotation for the screw.

Fig. 9-1 Réglage de la vitesse de défilement de la bande

### DE L'UNITÉ PRINCIPALE

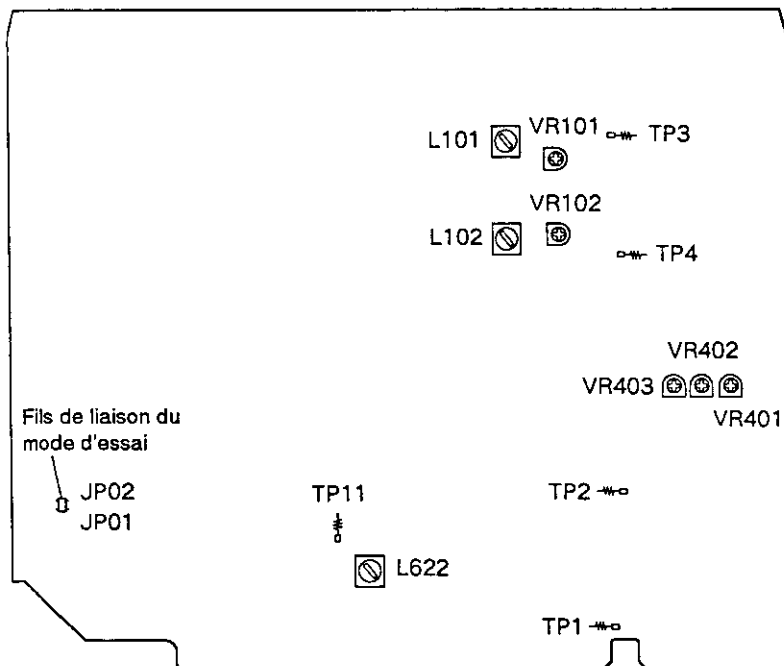

### UNITE HX

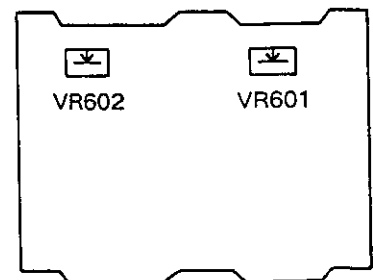

Fig. 9-2 Points de réglage

## 9.2 REGLAGES ELECTRIQUES

### Conditions de réglage

1. Les réglages mécaniques doivent tout d'abord être terminés.
2. Les têtes doivent être nettoyées et démagnétisées.
3. Mettre la platine sous tension et la laisser chauffer pendant au moins quelques minutes avant de commencer les réglages électriques.
4. Le signal de référence est de 0 dBV=1 Vrms.
5. Connecter une résistance de charge de 50 kΩ (tolérance 47k à 52 kΩ) aux bornes de sortie (OUTPUT).
6. Sauf indication contraire, les commutateurs ci-dessous doivent être laissés sur les positions indiquées.

DOLBY NR : OFF  
 Sélecteur de bande : NORM  
 (TAPE SELECTOR)

### Bandes d'essai

- STD-331E : Réglages de la lecture  
 (Voir fig. 9-3)
- STD-631 : Bande vierge de type normal  
 STD-621 : Bande vierge de type chrome  
 STD-610 : Bande vierge de type métal

\* Le niveau d'enregistrement de référence étant de 250 nwb/m pour le STD-331E, le niveau d'enregistrement sera supérieur de 4 dB pour le STD-331B (160 nwb/m). Pour le réglage, tenir compte du type de bande utilisé.

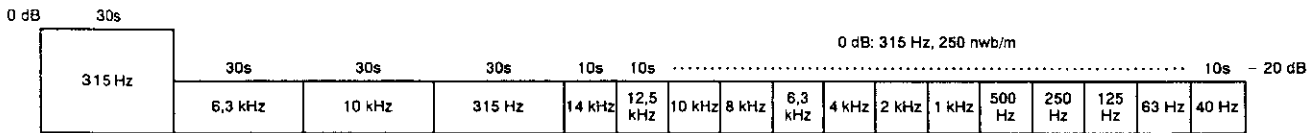

Fig. 9-3 Constantes de la bande d'essai STD-331E

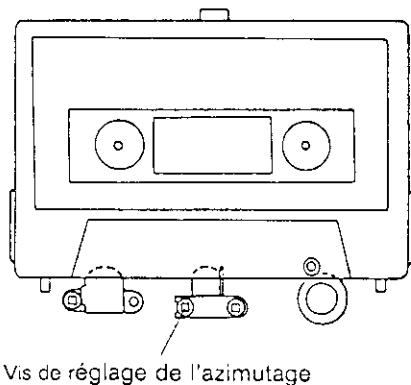

Fig. 9-4 Réglage de l'azimut de la tête

### Liste des réglages

#### Sections de lecture

1. Réglage de l'azimut de la tête.
2. Réglage du niveau de lecture.

#### Sections d'enregistrement

1. Réglage de l'oscillateur de polarisation.
2. Réglage du circuit réjecteur de polarisation.
3. Réglage de la polarisation d'enregistrement.
4. Réglage du niveau d'enregistrement.
5. Réglage de AUTO BLE

REMARQUE:  
 Cette unité est dotée d'une sélection automatique de bande.

### LECTURE

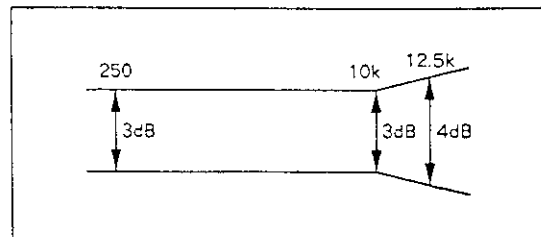

### ENREGISTREMENT

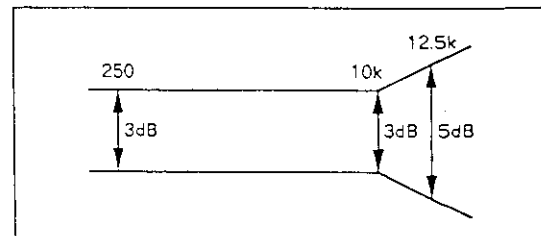

Fig. 9-5 Tolérance de la zone de réponse en fréquence de lecture

## SECTION DE LECTURE

## 1. Réglage de l'azimut de la tête

- Tourner VR101, 102 sur leur position centrale mécanique.

No.	Mode	Signal d'entrée et bande d'essai	Points de réglage	Points de mesure	Valeur de réglage	Remarques
1.	PLAY	Reproduire la section 10 kHz/-20 dB de la bande d'essai STD-331E.	Vis de réglage de l'azimut de la tête. (Voir fig. 9-4)		Sortie de ligne (LINE OUT)	Niveau du signal de reproduction maximum.
2.	STOP	Verrouiller la vis avec le verrouillage de vis après avoir terminé le réglage.				

## 2. Réglage du niveau de lecture

- Ce réglage détermine le niveau DOLBY NR et il doit être effectué très soigneusement.

No.	Mode	Signal d'entrée et bande d'essai	Points de réglage	Points de mesure	Valeur de réglage	Remarques	
1.	PLAY	Reproduire la section 315 Hz/0 dB de la bande d'essai STD-331E.	Platine	VR101 (can. G) VR102 (can. D)	TP. 3 (can. G) TP. 4 (can. D)	-6,7 dBV	Ce réglage doit être effectué avec précision pour un réglage adéquat du niveau Dolby.

## SECTION D'ENREGISTREMENT

## 1. Réglage de l'oscillateur de polarisation

No.	Mode	Signal d'entrée et bande d'essai	Points de réglage	Points de mesure	Valeur de réglage	Remarques
1.	REC	Charger la bande d'essai STD-610 et n'introduire aucun signal.	Platine	L622	TP. 11	105 kHz $\pm$ 0,3 kHz

## 2. Réglage du circuit réjecteur de polarisation

No.	Mode	Signal d'entrée et bande d'essai	Points de réglage	Points de mesure	Valeur de réglage	Remarques
1.	REC	Charger la bande d'essai STD-610 et n'introduire aucun signal.	Platine	L101 (can.G) L102 (can.D)	Sortie de ligne (LINE OUT)	Sortie minimum

## 3. Réglage de la polarisation d'enregistrement

- Après le réglage, des précautions doivent être prises pour éviter une sous-polarisation en vérifiant le taux de distorsion.

No.	Mode	Signal d'entrée et bande d'essai	Points de réglage	Points de mesure	Valeur de réglage	Remarques
1.	REC	Charger la cassette l'essai STD-631. Enregistrer les signaux 315 Hz et 10 kHz à un niveau d'entrée de -20 dBV et les reproduire.	Platine	VR601 (can. G) VR602 (can. D)	Sortie de ligne (LINE OUT)	Enregistrer, reproduire et régler de manière répétée de sorte que le niveau de lecture du signal 10 kHz devienne 0 dB $\pm$ 0,5 dB lorsqu'il est comparé avec le signal 315 Hz.

**4. Réglage du niveau d'enregistrement**

No.	Mode	Signal d'entrée et bande d'essai	Points de réglage		Points de mesure	Valeur de réglage	Remarques
1.	REC/ PAUSE	Appliquer un signal de 315 Hz/ - 4 dB aux bornes d'entrée de ligne, charger la bande d'essai STD-631.	Volume de la commande de niveau d'enregistrement.		TP. 1 (can. G) TP. 2 (can. D)	-11,2 dBV	
2.	REC/ PLAY	Enregistrer le signal cidessus sur la bande d'essai STD-631 et le reproduire.	Platine	VR601 (can. G) VR602 (can. D)	TP. 3 (can. G) TP. 4 (can. D)	Enregistrer, reproduire et régler de manière répétée de sorte que le niveau du signal devienne -11,2 dBV.	
3.	REC/ PLAY	Enregistrer le signal cidessus sur la bande d'essai STD-621 et le reproduire.	Vérifier		TP. 3 (can. G) TP. 4 (can. D)	-11,2 dBV ± 1,5 dB	
4.	REC/ PLAY	Enregistrer le signal cidessus sur la bande d'essai STD-610 et le reproduire.	Check		TP. 3 (can. G) TP. 4 (can. D)	-11,2 dBV ± 1,5 dB	

**5. Réglage de AUTO BLE**

- Le réglage BLE doit être effectué après que tous les autres réglages sont complétés.
- Ce réglage doit être effectué dans le mode d'essai.
- Voir la page 27 pour l'implantation du mode d'essai.

No.	Mode	Signal d'entrée et bande d'essai	Points de réglage	Points de mesure	Valeur de réglage	Remarques
1.		Régler dans le mode d'essai.	-	-	-	
2.		Appuyer sur la touche AUTO BLE du panneau avant.	L'indicateur de niveau can. D	VR401	Régler de sorte que - 3 dB clignote au vu-mètre.	Réglage 400 kHz (Indication FL 1) (Mode déssai 1)
3.	Appuyer sur la touche AUTO BLE du panneau avant.	VR402		Régler de sorte que - 3 dB clignote au vu-mètre.	Réglage 3 kHz (Indication FL 2) (Mode déssai 2)	
4.	Appuyer sur la touche AUTO BLE du panneau avant.	VR403		Régler de sorte que - 3 dB clignote au vu-mètre.	Réglage 15 kHz (Indication FL 3) (Mode déssai 3)	



# 9. AJUSTES

## 9.1 AJUSTE MECANICO

1. Ajuste de la velocidad de la cinta			
Mode	Cinta de prueba	Posición de ajuste	Valor de especificación (frecuencia de reproducción)
PLAY	Reproducir la STD-301 (3kHz)	Orificio de ajuste de la velocidad de la cinta	3000Hz + 5Hz

  

Figura 9-1 Ajuste de la velocidad de la cinta

### DE LA UNIDAD PRINCIPAL



### UNIDAD HX

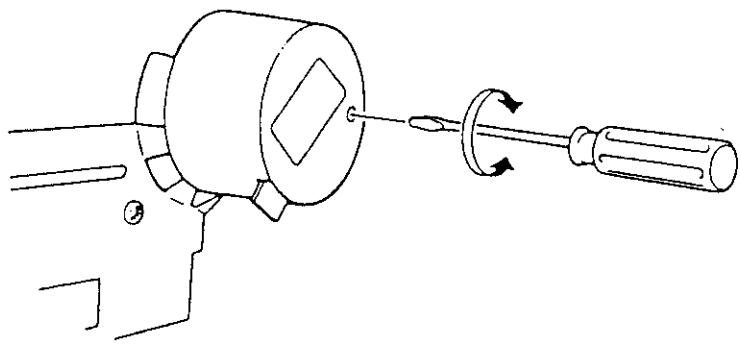
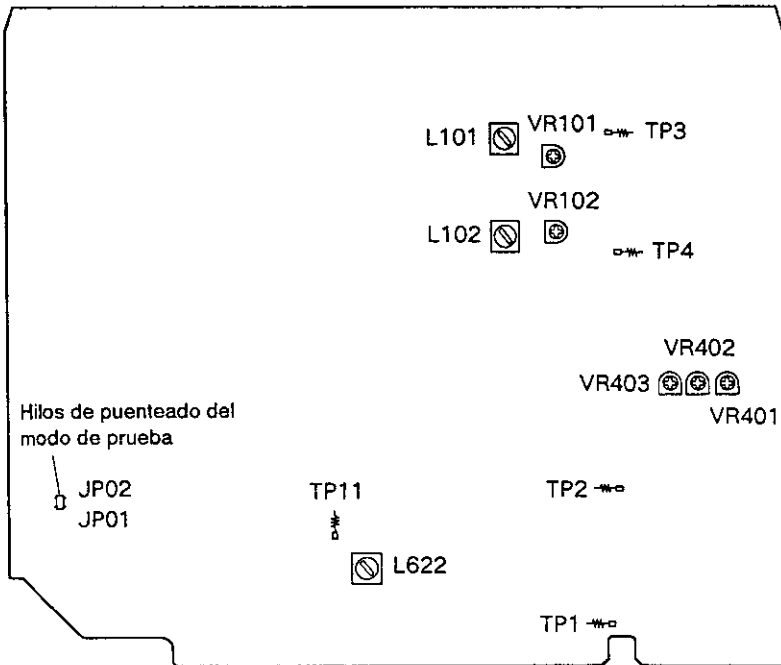

Figura 9-2 Puntos de ajuste

## 9.2 AJUSTES ELÉCTRICOS

### Condiciones de ajuste

1. Los ajustes mecánicos deben haberse completado primero.
2. La cabeza debe estar limpia y desmagnetizada.
3. Encienda la alimentación para permitir que la platina se caliente durante unos pocos minutos por lo menos antes de realizar cualquier ajuste eléctrico.
4. La señal de referencia es de 0 dBV=1 Vrms.
5. Conecte una resistencia de 50 kΩ (o entre 47k y 52 kΩ ) en los terminales OUTPUT.
6. A menos que se especifique lo contrario, los conmutadores indicados más abajo deben dejarse en las posiciones indicadas.

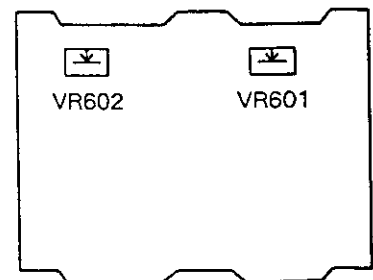
DOLBY NR : OFF  
 TAPE SELECTOR : NORM

### Cintas de prueba

- STD-331E : Ajustes de reproducción  
 (Consulte la figura 9-3)
- STD-631 : Cinta virgen NORMAL
- STD-621 : Cinta virgen de CrO<sub>2</sub>
- STD-610 : Cinta virgen de METAL

\* Como el nivel de grabación de referencia es igual a 250 nwb/m para el STD-331E, el nivel de grabación será 4 dB mayor para el STD-331B (160 nwb/m). Al realizar el ajuste, preste suma atención al tipo de cintá que se está utilizando.

### Lista de ajustes

#### Secciones de reproducción

1. Ajuste de azimut de la cabeza
2. Ajuste del nivel de reproducción

#### Secciones de grabación

1. Ajuste del oscilador de polarización
2. Ajuste del eliminador de polarización
3. Ajuste de la polarización de grabación
4. Ajuste del nivel de grabación
5. Ajuste AUTO BLE

**NOTA:**  
 Esta unidad posee una función de selección automática de cinta.



Figura 9-3 Constantes de la cinta de prueba STD-331E



Figura 9-4 Ajuste de azimut de la cabeza

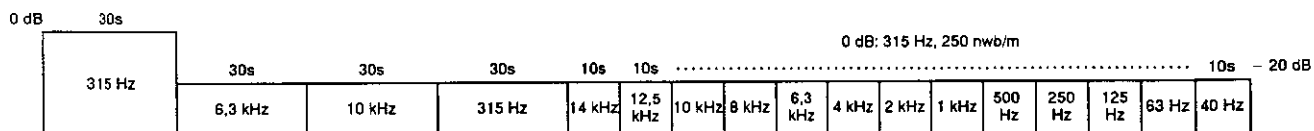

Figura 9-5 Zona permisible de respuesta de frecuencia de reproducción

## SECCIÓN DE REPRODUCCIÓN

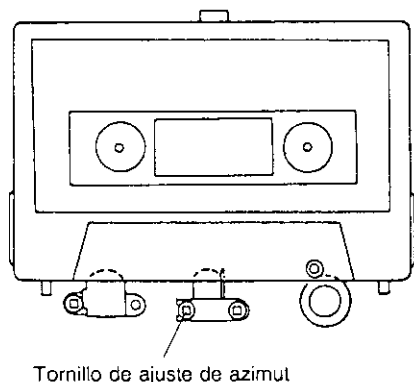
### 1. Ajuste del azimut de la cabeza

- Poner VR101, 102 en las posiciones del centro mecánico.

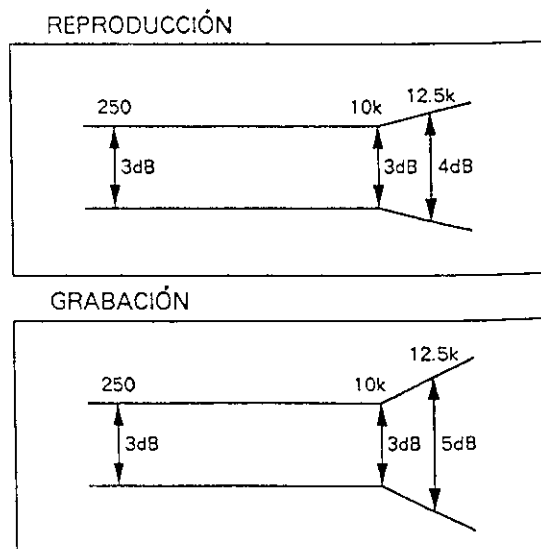
N.º	Modo	Señal de entrada y cinta de prueba	Punto de ajuste	Punto de medición	Valor de ajuste	Comentarios
1.	PLAY	Reproduzca la sección de 10 kHz/-20 dB de la cinta de prueba STD-331E.	Tornillo de ajuste del azimut de la cabeza. (Vea la figura 8-4)	LINE OUT	Nivel máximo de la señal de reproducción.	
2.	STOP	Bloquee el tornillo con su cierre una vez finalizado el ajuste.				

### 2. Ajuste del nivel de reproducción

- Este ajuste determina el nivel DOLBY NR y debe realizarse con mucho cuidado.

N.º	Modo	Señal de entrada y cinta de prueba	Punto de ajuste	Punto de medición	Valor de ajuste	Comentarios
1.	PLAY	Produzca la parte de 315 Hz/0 dB de la cinta de prueba STD-331E.	Platina VR101 (Lch) VR102 (Rch)	TP. 3 (Lch) TP. 4 (Rch)	-6,7 dBV	Este ajuste debe efectuarse con precisión para lograr un buen reglaje del nivel Dolby.

## SECCIÓN DE GRABACIÓN

### 1. Ajuste del oscilador de polarización

N.º	Modo	Señal de entrada y cinta de prueba	Punto de ajuste	Punto de medición	Valor de ajuste	Comentarios
1.	REC	Introduzca la cinta de prueba STD-610 sin señal de entrada.	Platina L622	TP. 11	105 kHz $\pm$ 0,3 kHz	

### 2. Ajuste del eliminador de polarización

N.º	Modo	Señal de entrada y cinta de prueba	Punto de ajuste	Punto de medición	Valor de ajuste	Comentarios
1.	REC	Introduzca la cinta de prueba STD-610 sin señal de entrada.	Platina L101 (Lch) L102 (Rch)	LINE OUT	Salida mínima	

### 3. Ajuste de polarización de grabación

- Una vez finalizado el ajuste, compruebe el porcentaje de distorsión para no obtener subpolarización.

N.º	Modo	Señal de entrada y cinta de prueba	Punto de ajuste	Punto de medición	Valor de ajuste	Comentarios
1.	REC	Coloque la cinta de prueba STD-631. Grabe la señal de 315 Hz y 10 kHz a un nivel de entrada de -20 dBV y reproduzca.	Platina VR601 (Lch) VR602 (Rch)	LINE OUT	Grabe, reproduzca y ajuste repetidamente para que el nivel de la señal de reproducción de 10 kHz sea de + 0 dB $\pm$ 0,5 dB cuando se compare con la señal de 315 Hz.	

**4. Ajuste del nivel de grabación**

N.º	Modo	Señal de entrada y cinta de prueba	Punto de ajuste		Punto de medición	Valor de ajuste	Comentarios
1.	REC/ PAUSE	Aplice una señal de 315 Hz/ - 4 dB a los terminales de entrada de línea e introduzca la cinta de prueba STD-631.	Control de nivel de grabación.		TP. 1 (Lch) TP. 2 (Rch)	-11,2 dBV	
2.	REC/ PLAY	Grabe la señal de arriba en la cinta de prueba STD-631 y reproduzca.	Platina	VR601 (Lch) VR602 (Rch)	TP. 3 (Lch) TP. 4 (Rch)	Grabe, reproduzca y ajuste repetidamente para que el nivel de la señal de reproducción sea de -11,2 dBV.	
3.	REC/ PLAY	Grabe la señal de arriba en la cinta de prueba STD-621 y reproduzca.	Verifique		TP. 3 (Lch) TP. 4 (Rch)	-11,2 dBV ± 1,5 dB	
4.	REC/ PLAY	Grabe la señal de arriba en la cinta de prueba STD-610 y reproduzca.	Verifique		TP. 3 (Lch) TP. 4 (Rch)	-11,2 dBV ± 1,5 dB	

**5. Ajuste AUTO BLE**

- El ajuste BLE debe efectuarse después de haber terminado todos los otros ajustes.
- Este ajuste debe efectuarse en el modo de prueba.
- Con respecto al ajuste del modo de prueba, consulte la página 28.

N.º	Modo	Señal de entrada y cinta de prueba	Punto de ajuste	Punto de medición	Valor de ajuste	Comentarios
1.		Establezca el modo de prueba.	-	-	-	
2.		Pulse la tecla AUTO BLE del panel delantero.	En medidor de nivel Rch	VR401	Ajuste en forma tal que - 3 dB se ilumine intermitentemente en el medidor de nivel.	Ajuste de 400 kHz (Indicación de FL 1) (Modo de prueba 1)
3.		Pulse la tecla AUTO BLE del panel delantero.		VR402	Ajuste en forma tal que - 3 dB se ilumine intermitentemente en el medidor de nivel.	Ajuste de 3 kHz (Indicación de FL 2) (Modo de prueba 2)
4.		Pulse la tecla AUTO BLE del panel delantero.		VR403	Ajuste en forma tal que - 3 dB se ilumine intermitentemente en el medidor de nivel.	Ajuste de 15 kHz (Indicación de FL 3) (Modo de prueba 3)

# 10. FOR CT-S510/HB, CT-S410/KUC, HEM AND HB TYPES

## CONTRAST OF MISCELLANEOUS PARTS

### NOTES:

- Parts marked by "NSP" are generally unavailable because they are not in our Master Spare Parts List.
- The  $\Delta$  mark found on some component parts indicates the importance of the safety factor of the part. Therefore, when replacing, be sure to use parts of identical designation.
- Parts marked by "⊙" are not always kept in stock. Their delivery time may be longer than usual or they may be unavailable.

**CT-S510/HB, CT-S410/KUC, HEM, HB and CT-S510/HEM have the same construction except for the following:**

Mark	Symbol & Description	Part No.					Remarks
		CT-S510/ HEM type	CT-S510/ HB type	CT-S410/ KUC type	CT-S410/ HEM type	CT-S410/ HB type	
⊙	Mother unit	RWM1498	RWM1542	RWM1497	RWM1496	RWM1514	
NSP	└ MAIN unit	RWZ2589	RWZ2589	RWZ2579	RWZ2579	RWZ2579	
NSP	└ TRN 1 unit	RWZ2678	RWZ2679	RWZ2583	RWZ2678	RWZ2679	
NSP	└ TRN 2 unit	RWZ2586	RWZ2586	RWZ2584	RWZ2586	RWZ2586	
NSP	└ DISP unit	RWZ2590	RWZ2590	RWZ2587	RWZ2585	RWZ2585	
$\Delta$	Strain relief	CM-22B	CM-22B	CM-22C	CM-22B	CM-22B	
$\Delta$	AC power cord	PDG1003	PDG1036	PDG1015	PDG1003	PDG1036	
$\Delta$	Fuse (1A)	REK-100	REK-100	REK-080	REK-100	REK-100	
$\Delta$	Power transformer (AC220 – 230V/230 – 240V)	RTT1195	RTT1195	.....	RTT1195	RTT1195	
$\Delta$	Power transformer (AC120V)	.....	.....	RTT1196	.....	.....	
	FL lens	RAH2030	RAH2030	RAH1867	RAH1870	RAH1870	
	Front panel assembly	RXX1466	RXX1466	RXX1467	RXX1467	RXX1467	
NSP	Front panel	RNT1131	RNT1131	RNT1132	RNT1132	RNT1132	
NSP	Rear panel	RNA1514	RNA1514	RNA1517	RNA1515	RNA1515	
	Packing case	RHG1324	RHG1324	RHG1326	RHG1325	RHG1325	
	Connection cord (with mini plug)	.....	.....	PDE-319	PDE-319	PDE-319	(Packing)
	Operating instructions (German/Italian/ Dutch/Swedish/Spanish/Portuguese)	RRD1131	.....	.....	RRD1131	.....	
	Vinyl bag	RHL1001	RHL1001	.....	.....	.....	
	Remote control unit	RPX1059	RPX1059	.....	.....	.....	
	Battery cover	PZN1010	PZN1010	.....	.....	.....	
NSP	Dry cell battery (R03, AAA)	VEM-022	VEM-022	.....	.....	.....	
NSP	Capacitor sleeve A	REC – 150	REC – 150	.....	REC – 150	REC – 150	

### MAIN UNIT

**RWZ2589 and RWZ2579 have the same construction except for the following;**

Mark	Symbol & Description	Part No.		Remarks
		RWZ2589	RWZ2579	
	C853	.....	CKCYF473Z50	
	JA851, 852 Jack (Remote control)	.....	RKN1004	

**TRN 1 UNIT**

Although RWZ2678, RWZ2679 and different in part number, they have the same same service parts.

Although RWZ2678, RWZ2679 and RWZ2583 are different in part number, they have the same service parts.

**TRN 2 UNIT**

Although RWZ2586 and RWZ2584 are different in part number, they have the same service parts.

**DISP UNIT**

RWZ2590, RWZ2587 and RWZ2585 have the same construction except for the following;

Mark	Symbol & Description	Part No.			Remarks
		RWZ2590	RWZ2587	RWZ2585	
	V1401 FL tube IC1401 Remote sensor	RAW1112 HC - 177	RAW1113 .....	RAW1112 .....	

# 11. PANEL FACILITIES

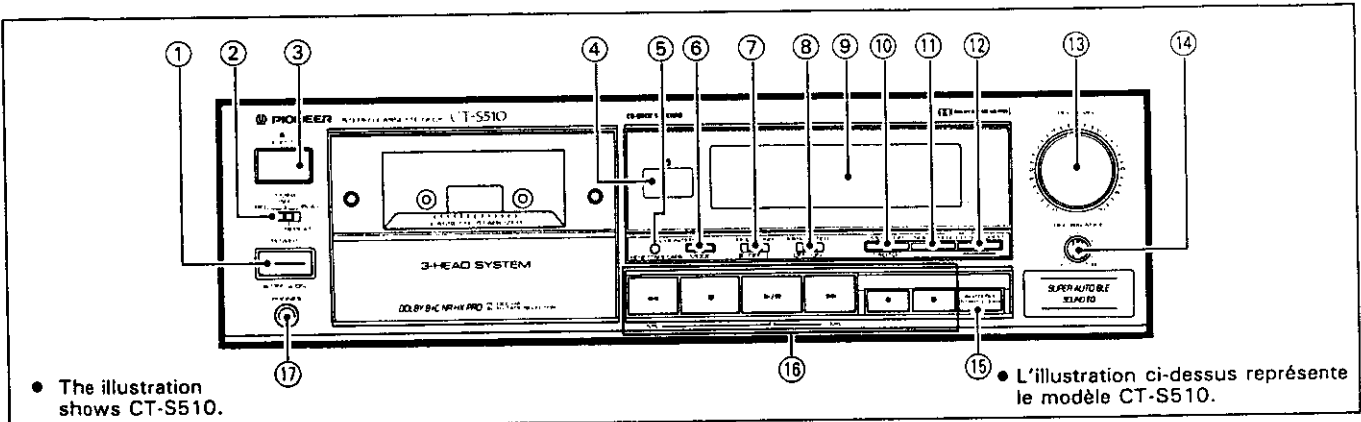

• The illustration shows CT-S510.

• L'illustration ci-dessus représente le modèle CT-S510.

- ① Power switch (POWER  $\blacksquare$  OFF /  $\blacktriangle$  ON)
- ② Timer mode /repeat play switch (TIMER REC/OFF/PLAY-REPEAT)
- ③ Eject button (EJECT  $\blacktriangle$ )
  - If the tape is moving (recording, playback, tape winding, etc.), press the stop ( $\blacksquare$ ) button before pressing this button.
- ④ Remote sensor window (CT-S510 only)
- ⑤ Counter reset/tape capacity selector button (COUNTER RESET/TAPE CAPA)
- ⑥ Tape counter mode button (COUNTER MODE)
- ⑦ Dolby\* NR switch (DOLBY NR B/OFF/C)
- \*
  - *Dolby noise reduction and HX Pro headroom extension manufactured under license from Dolby Laboratories Licensing Corporation. HX Pro originated by Bang & Olufsen.*
  - *"DOLBY", the double-D symbol  $\square\square$  and "HX PRO" are trademarks of Dolby Laboratories Licensing Corporation.*
- ⑧ MPX FILTER switch (OFF/ON)
- ⑨ Function display
- ⑩ Monitor selector button (MONITOR [AUTO])
  - Used to monitor the source sound or just recorded source during recording.
  - When the unit is set to record or playback mode, the TAPE indicator light up and the monitor mode is automatically selected.
- ⑪ SOUND EQ button
- ⑫ CD•DECK SYNCHRO recording button (CD SYNCHRO)
- ⑬ Recording level control (REC LEVEL)
- ⑭ Recording balance control (REC BALANCE)
- ⑮ SUPER AUTO BLE START/CLEAR button
- ⑯ Operation buttons
  - $\ll$ /MS : Rewind/music search
  - $\blacksquare$  : Stop
  - $\triangleright$  /  $\parallel$  : When pressed during stop, begins playback. When pressed during playback, pauses playback. When pressed during pause, resumes play or starts recording.
  - $\gg$ /MS : Fast forward/music search
  - $\bullet$  : Recording
  - $\circ$  : Recording mute
- ⑰ Headphones jack (PHONES)

## 11. PANEL FACILITIES

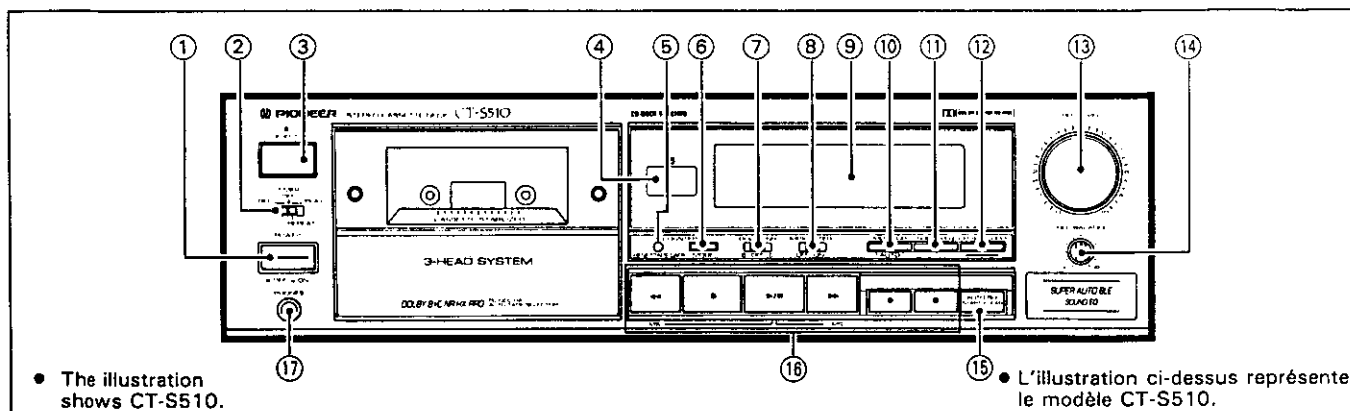

• The illustration shows CT-S510.

• L'illustration ci-dessus représente le modèle CT-S510.

- ① Power switch (POWER  $\blacksquare$  OFF/  $\blacktriangle$  ON)
- ② Timer mode /repeat play switch (TIMER REC/OFF/PLAY-REPEAT)
- ③ Eject button (EJECT  $\blacktriangle$ )
  - If the tape is moving (recording, playback, tape winding, etc.), press the stop ( $\blacksquare$ ) button before pressing this button.
- ④ Remote sensor window (CT-S510 only)
- ⑤ Counter reset/tape capacity selector button (COUNTER RESET/TAPE CAPA)
- ⑥ Tape counter mode button (COUNTER MODE)
- ⑦ Dolby\* NR switch (DOLBY NR B/OFF/C)
- \*
  - *Dolby noise reduction and HX Pro headroom extension manufactured under license from Dolby Laboratories Licensing Corporation. HX Pro originated by Bang & Olufsen.*
  - "DOLBY", the double-D symbol  $\square\square$  and "HX PRO" are trademarks of Dolby Laboratories Licensing Corporation.
- ⑧ MPX FILTER switch (OFF/ON)
- ⑨ Function display
- ⑩ Monitor selector button (MONITOR [AUTO])
  - Used to monitor the source sound or just recorded source during recording.
  - When the unit is set to record or playback mode, the TAPE indicator light up and the monitor mode is automatically selected.
- ⑪ SOUND EQ button
- ⑫ CD•DECK SYNCHRO recording button (CD SYNCHRO)
- ⑬ Recording level control (REC LEVEL)
- ⑭ Recording balance control (REC BALANCE)
- ⑮ SUPER AUTO BLE START/CLEAR button
- ⑯ Operation buttons
  - $\ll$ /MS : Rewind/music search
  - $\blacksquare$  : Stop
  - $\triangleright$  /  $\parallel$  : When pressed during stop, begins playback. When pressed during playback, pauses playback. When pressed during pause, resumes play or starts recording.
  - $\gg$ /MS : Fast forward/music search
  - $\bullet$  : Recording
  - $\circ$  : Recording mute
- ⑰ Headphones jack (PHONES)



FUNCTION DISPLAY

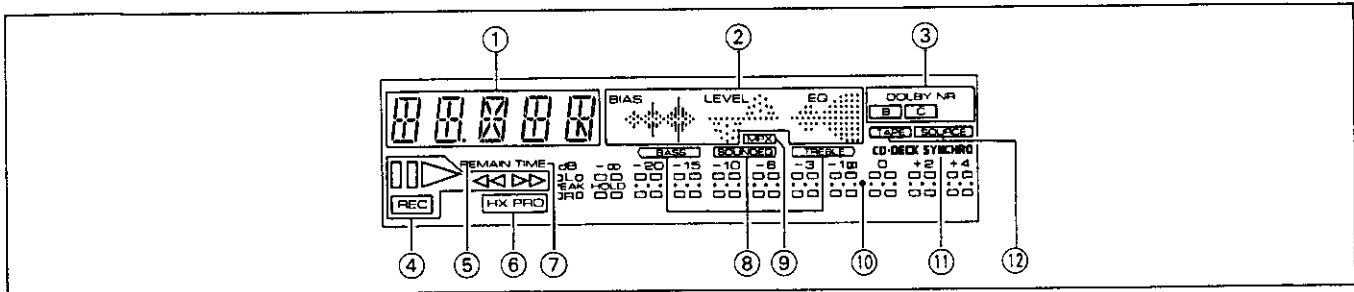

① Counter indicator

Normally the tape or time counter is displayed number (see "COUNTER MODES").

**POWER** : Flashes for four seconds after turning the power on.

**TIMER** : Lights for approximately 10 seconds after starting **TIMER PLAY** or **TIMER REC**.

Immediately returns to normal counter mode if any button is pressed while lighted.

Otherwise, returns to normal counter mode after 10 seconds.

During **AUTO BLE** tuning, indicates **STRT**, **BIAS**, **LEVEL**, **EQ**, **TUNED** or **Error**.

② AUTO BLE indicator

③ DOLBY NR B/C indicator

④ Tape transport mode indicators

▶ : Lights during recording or playback or play/pause mode. Flashes during music search operation.

⏏ : Lights during pause.

REC : Lights during recording and recording pause (standby) modes. Flashes during recording mute.

▶▶ : Lights during fast forward and music search operation.

◀◀ : Lights during fast reverse and music search operation.

⑤ REMAIN counter indicator

Lights up in the remaining time **COUNTER** mode.

⑥ DOLBY HX PRO indicator

⑦ TIME counter indicator

Lights up in the time counter mode or **REMAN** counter mode.

⑧ SOUND EQ indicators

Press the **SOUND EQ** button to **ON** to light the indicators. Different parts of the indicator (**BASS**, **SOUND EQ**, **TREBLE**) light with alternate presses of the button.

⑨ MPX indicator

This indicator lights when the **MPX** filter switch is set to **ON** (only when **DOLBY NR** is also set to **ON**).

⑩ Level meter

The ◻◻ beside the **-1 dB** mark indicates the **Dolby NR** systems reference level.

⑪ CD-DECK SYNCHRO indicator

Lights when **synchro** recording from a **CD** player is being carried out.

⑫ Monitor source indicators

**TAPE** : Recorded sound

**SOURCE** : Original source sound