

Service Manual

ORDER NO.
RRV1266

SEPARATE MINI COMPONENT SYSTEM

XS-P650

● Refer to the service manual RRV1256 for XS-P550.

THIS MANUAL IS APPLICABLE TO THE FOLLOWING MODEL(S) AND TYPE(S).

Type	Model	Power Requirement	Remarks
	XS-P650		
MEXK/EA	○	AC220-230V	
MEXK/EB	○	AC220-230V	
MEZIXK/DI	○	AC220-230V	
NBXX	○	AC230V	

● XS-P650 is a combination of the following components.

STEREO AMPLIFIER : A-P650
 FM/AM DIGITAL SYNTHESIZER TUNER : F-P550RDS
 COMPACT DISC PLAYER : PD-P550
 STEREO DOUBLE CASSETTE DECK : CT-P550WR

● This product does not function properly when independent; to avoid malfunctions, be sure to connect it to the prescribed system component(s), otherwise damage may result.

● This product is a component of a system.

For the system composition FM/AM DIGITAL SYNTHESIZER TUNER: F-P550, COMPACT DISC PLAYER: PD-P550 and STEREO DOUBLE CASSETTE DECK: CT-P550WR etc., refer to the service manual RRV1256 for XS-P550.

● This manual is applicable to STEREO AMPLIFIER: A-P650.

CONTENTS

1. DISASSEMBLY	2	4. BLOCK DIAGRAM	17
2. EXPLODED VIEWS, PACKING AND PARTS LIST	3	5. PCB PARTS LIST	18
3. SCHEMATIC AND PCB CONNECTION DIAGRAMS	7	6. IC INFORMATION	23
		7. FL INFORMATION	27

PIONEER ELECTRONIC CORPORATION 4-1, Meguro 1-Chome, Meguro-ku, Tokyo 153, Japan

PIONEER ELECTRONICS SERVICE INC. P.O. Box 1760, Long Beach, California 90801, U.S.A.

PIONEER ELECTRONICS OF CANADA, INC. 300 Allstate Parkway Markham, Ontario L3R 0P2, Canada

PIONEER ELECTRONIC [EUROPE] N.V. Haven 1087 Keetberglaan 1, 9120 Melsele, Belgium

PIONEER ELECTRONICS AUSTRALIA PTY. LTD. 178-184 Boundary Road, Braeside, Victoria 3195, Australia, TEL: [03] 580-9911

© **PIONEER ELECTRONIC CORPORATION** 1995

T-DFY MAY 1995 Printed in Japan

1. DISASSEMBLY (A – P650)

● Removal of the Front Panel

1. Remove the bonnet.
2. Remove the volume knob.
(Please be careful, as the STA. LENS is in the volume knob.)
3. Remove the screw ① holding the SFC assy.
4. Remove the left and right screw ② (each one) fixing the front panel to chassis.
5. Remove the three screws ③ at the lower side of the front panel.
6. Disengage the left and the right hook of the front panel (refer to figure) and the hook at the lower part, and then remove the front panel from the chassis.

● Removal of the Fan Motor

1. Remove the bonnet.
2. Remove the screw ④ of the rear panel.
3. Remove the screw ⑤ of the connector.
4. Remove the screw ⑥ of the SP OUT terminal.
5. Remove the screw ⑦ of the pin jack.
6. Remove the rear panel from the chassis.
7. Remove the screw ⑧ of the fan motor.

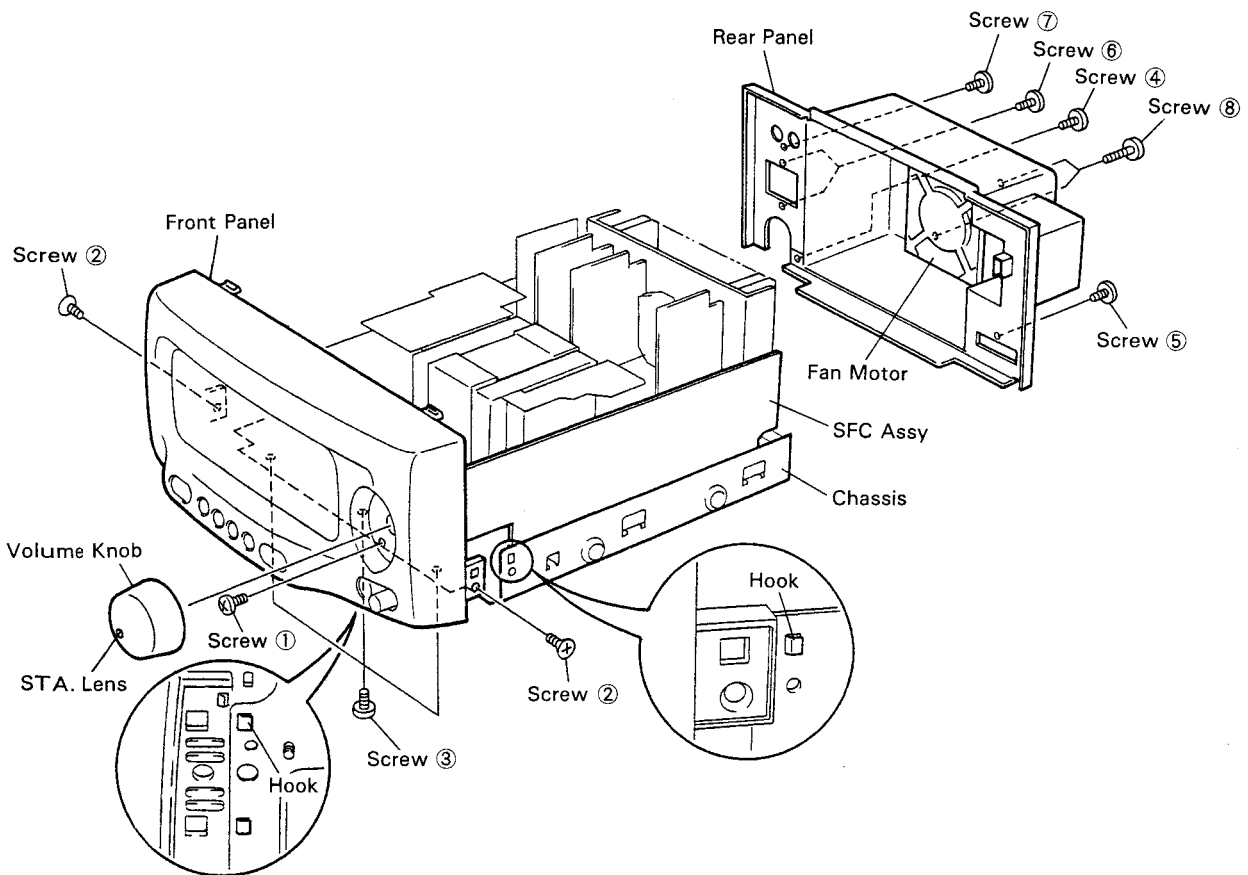

2.2 EXTERIOR (A – P650)

Mark	No.	Description	Parts No.	Mark	No.	Description	Parts No.
	1	DISPLAY ASSY	RWZ3570		36	SCREW	BBZ30P080FZK
	2	MAIN ASSY (MEXK/EA, MEXK/EB and NBXK types)	RWZ3556		37	SCREW	BBZ30P160FMC
	2	MAIN ASSY (MEZIXK/DI type)	RWZ3565		38	SCREW	CBZ30P080FZK
NSP	3	H.P ASSY (MEXK/EA, MEXK/EB and NBXK types)	RWZ3571		39	SCREW	PPZ30P080FMC
NSP	3	H.P ASSY (MEZIXK/DI type)	RWZ3574		40	SCREW	PPZ30P100FZK
	4	SFC.VR ASSY (MEXK/EA, MEXK/EB and NBXK types)	RWZ3557		41	BINDER (SKB – 90BK)	Z09 – 056
	4	SFC.VR ASSY (MEZIXK/DI type)	RWZ3566	△	42	
NSP	5	CONNECT ASSY	RWZ3558		43	SCREW	ABA1053
	6	AC. CONNECT ASSY (MEXK/EA, MEXK/EB and NBXK types)	RWZ3573		44	FUSE (T5A) (NBXK type)	PEK1003
	6	AC. CONNECT ASSY (MEZIXK/DI type)	RWZ3576		45	MIC VOLUME KNOB	AAB7045
NSP	7	SP. OUT ASSY (MEXK/EA, MEXK/EB and NBXK types)	RWZ3572		46	FAN MOTOR	AXM1019
NSP	7	SP. OUT ASSY (MEZIXK/DI type)	RWZ3575		47	PRO. LOGIC ASSY (MEXK/EA, MEXK/EB and NBXK types)	RWZ3559
	8			47	PRO. LOGIC ASSY (MEZIXK/DI type)	RWZ3567
△	9	STRAIN RELEIF	CM – 22B		48	FRONT AMP ASSY (MEXK/EA, MEXK/EB and NBXK types)	RWZ3560
△	10	POWER CORD WITH PLUG (MEXK/EA, MEXK/EB and MEZIXK/DI types)	PDG1003		48	FRONT AMP ASSY (MEZIXK/DI type)	RWZ3568
△	10	POWER CORD WITH PLUG (NBXK type)	PDG1055		49	REAR AMP ASSY (MEXK/EA, MEXK/EB and NBXK types)	RWZ3561
	11	25P F • F • C/30V	RDD1333		49	REAR AMP ASSY (MEZIXK/DI type)	RWZ3569
△	12	FUSE (T1A, FU2002)	AEK1054		50	REGULATOR ASSY	RWZ3562
△	13	POWER TRANSFORMER	RTT1289	NSP	51	BALANCE VR ASSY	RWZ3563
NSP	14	PCB SPACER (3 × 8)	AEC1371	NSP	52	FAN CORD ASSY	RWZ3564
NSP	15	PCB SPACER (3 × 12)	AEC1372	NSP	53	PCB HOLDER	REC1258
	16	PCB MOULD	AMR2115		54	SCREW	PTZ45P100FZK
NSP	17	CORD HOLDER	DNF1128		55	SCREW	BBZ40P060FZK
NSP	18	CUSHION A	REB1283		56	
NSP	19	UNDER BASE	RNB1107		57	
NSP	20	HEAT SINK	RNE1840	NSP	58	SUB CHASSIS	RNE1845
	21	JOINT L	RNE1826	NSP	59	HOLDER	RNE1856
NSP	22	JOINT R	RNE1827				
	23	INSULATOR ASSY	RXA1673				
	24					
	25	STA. LENS	AAK7118				
	26	AM CONTROL BUTTON	RAC1990				
	27	AM BUTTON A	REA1166				
	28	AM BUTTON B	REA1167				
	29	VOLUME KNOB	AAB7046				
	30	AM FRONT PANEL	RAH2545				
	31	AM DISPLAY WINDOW	RAH2546				
	32	BONNET	REA1181				
	33	REAR PANEL	RNK2130				
	34	SCREW	ABA1005				
	35	SCREW	BBZ30P060FMC				

A

B

C

D

E

F

NOTE : Screws adjacent to ▼ mark on the product are used for disassembly.

4481

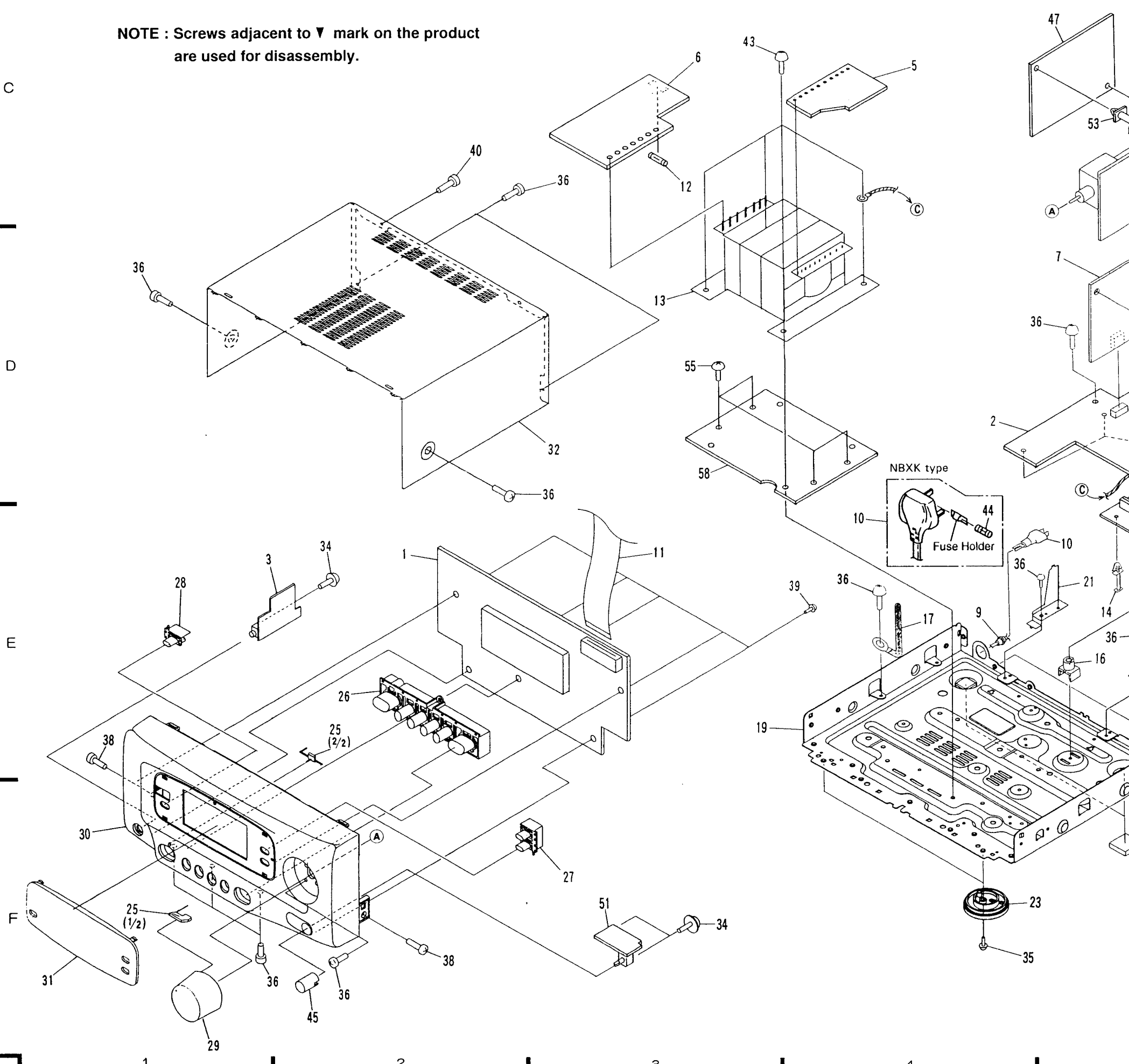

Work on the product

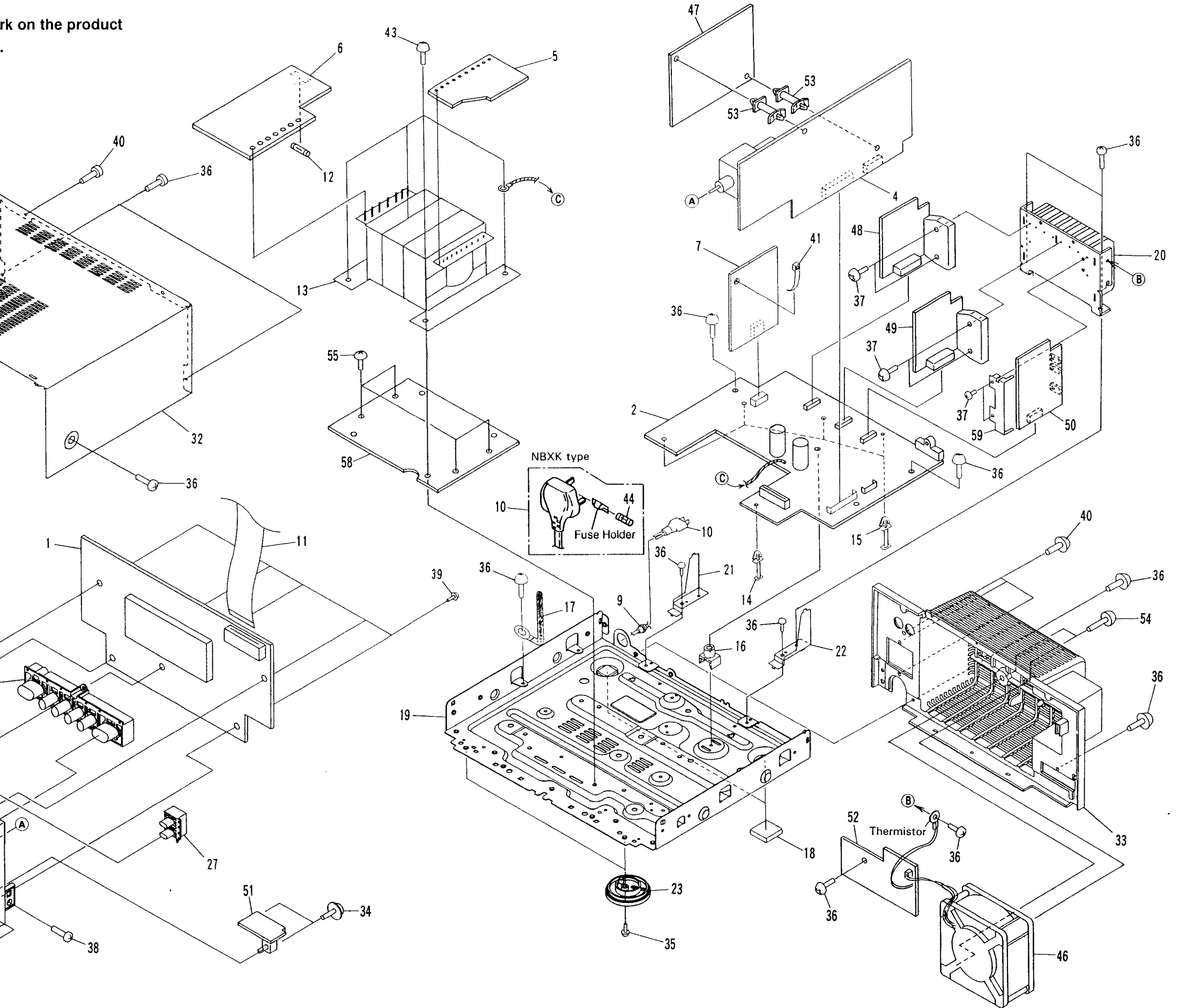

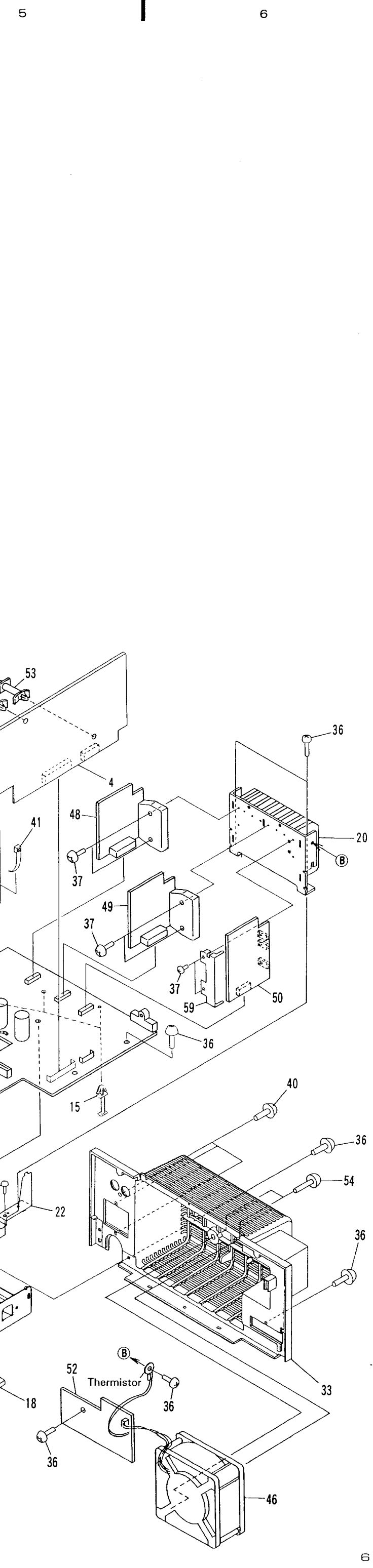

3. SCHEMATIC AND PCB CONNECTION DIAGRAMS

3.1 OVERALL SCHEMATIC DIAGRAM

SCH-1F

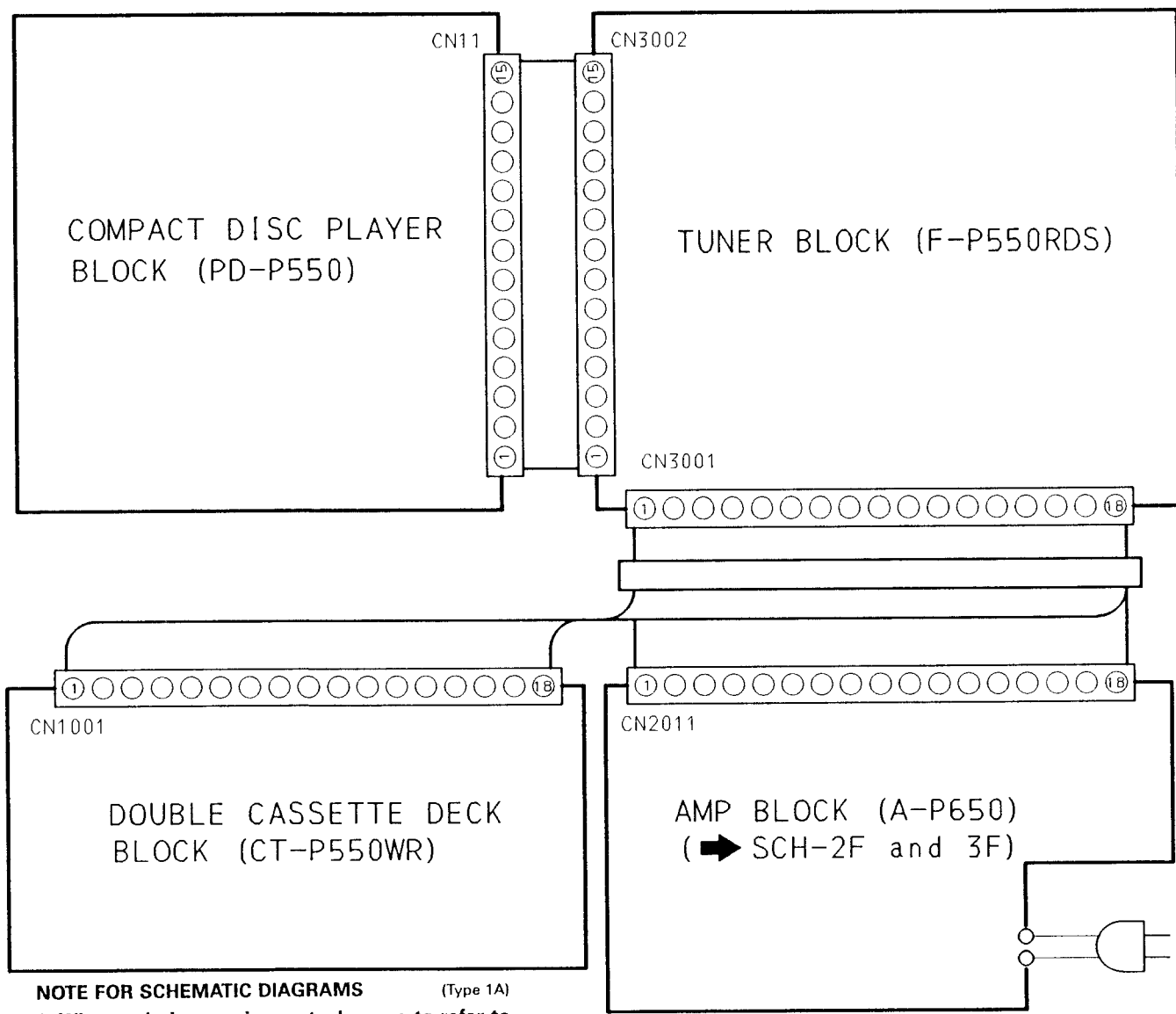

NOTE FOR SCHEMATIC DIAGRAMS (Type 1A)

1. When ordering service parts, be sure to refer to "PARTS LIST of EXPLODED VIEWS" or "PCB PARTS LIST".
2. Since these are basic circuits, some parts of them or the values of some components may be changed for improvement.
3. RESISTORS:
Unit: k: kΩ, M: MΩ, or Ω unless otherwise noted.
Rated power: 1/4W, 1/6W, 1/8W, 1/10W unless otherwise noted.
Tolerance: (F): ±1%, (G): ±2%, (K): ±10%, (M): ±20% or ±5% unless otherwise noted.
4. CAPACITORS:
Unit: p: pF or μF unless otherwise noted.
Ratings: capacitor (μF)/voltage (V) unless otherwise noted.
Rated voltage: 50V except for electrolytic capacitors.
5. COILS:
Unit: m: mH or μH unless otherwise noted.
6. VOLTAGE AND CURRENT:
V : Signal voltage at rated output.
V or - V : DC voltage (V) at no input signal unless otherwise noted. Value in () is DC voltage at rated power.
mA or - mA : DC current at no input signal unless otherwise noted.
7. OTHERS:
⊗ or ⊙ : Adjusting point.
⊛ : Measurement point.
The Δ mark found on some component parts indicates the importance of the safety factor of the parts. Therefore, when replacing, be sure to use parts of identical designation.
8. SCH-□ ON THE SCHEMATIC DIAGRAM:
SCH-□ indicates the drawing number of the schematic diagram. (SCH stands for schematic diagram.)

9. SWITCHES (Underline indicates switch position):

- A-P650
- DISPLAY ASSY
- S2501 WAKE-UP
- S2502 REC (TIMER)
- S2503 DOLBY MODE
- S2504 CENTER MODE
- S2505 P. BASS
- S2506 + (CLOCK)
- S2507 - (CLOCK)
- S2508 POWER
- S2509 SFC MODE

SCH-1F

OVERALL SCHEMATIC DIAGRAM

3.2 MAIN ASSY, SFC. VR ASSY, CONNECT ASSY, PRO. LOGIC ASSY, FRONT AMP ASSY, REAR AMP ASSY, REGULATOR ASSY, BALANCE VR ASSY, FAN CORD ASSY, H. P ASSY, SP. OUT ASSY AND AC. CONNECT ASSY

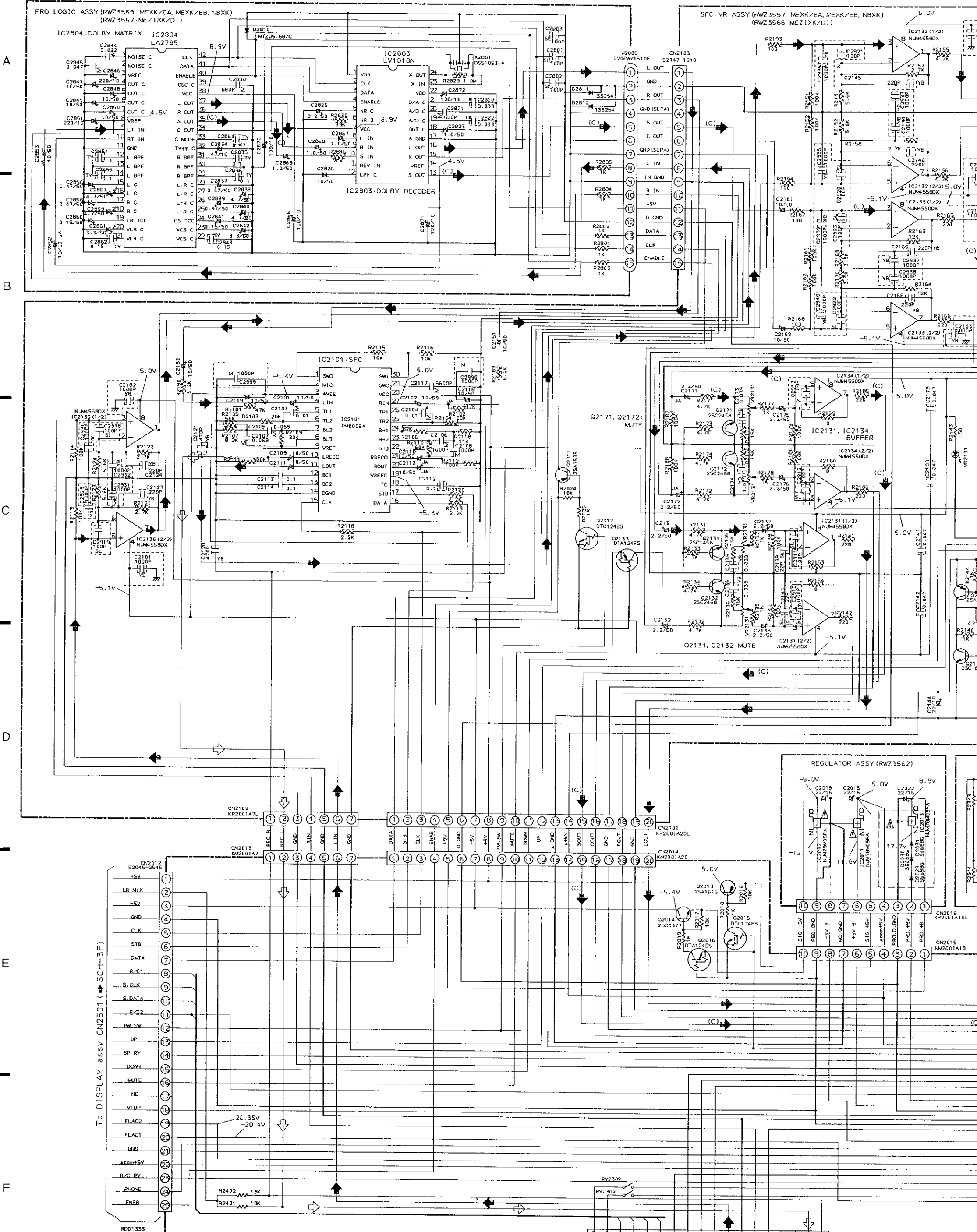

SCH-2F

MAIN ASSY, SFC. VR ASSY, CONNECT ASSY, PRO. LOGIC ASSY, FRONT AMP ASSY, REAR AMP ASSY, REGULATOR ASSY, BALANCE VR ASSY, FAN CORD ASSY, H. P ASSY, SP. OUT ASSY, AC. CONNECT ASSY

AC1 AC2 R/E1 S-CLK S-DATA R/E2 C-ENC O (DECK B) G(TX) G(TX B) PRE-L G(PRE) G(TC) PB-L PB-R REC-L REC-R

To PRE. AMP assy CN3001 and TC. MAIN assy CN1001

CONNECT ASSY, PRO. LOGIC ASSY, FRONT AMP ASSY,
 ASSY, BALANCE VR ASSY, FAN CORD ASSY, H. P ASSY,
 CT ASSY

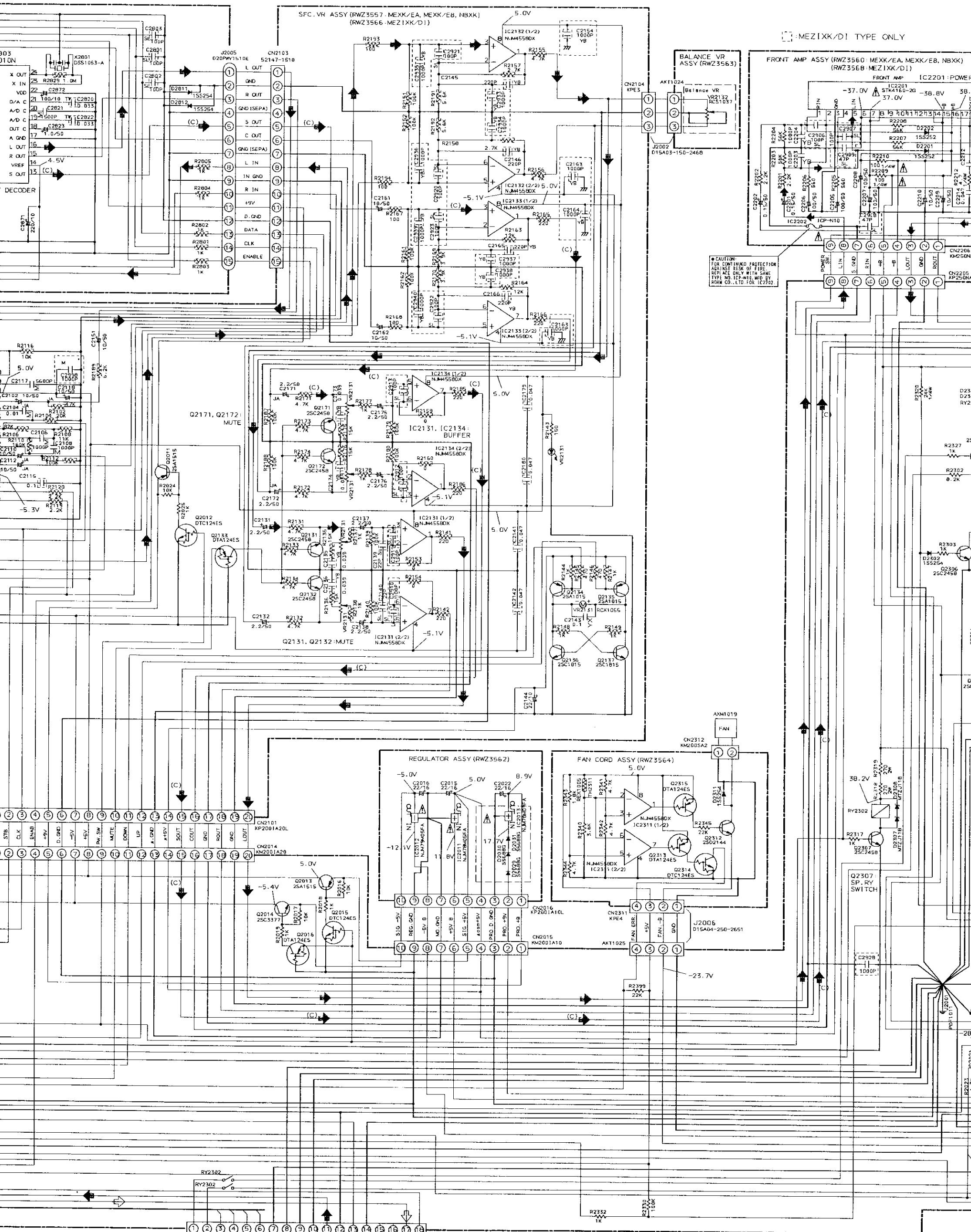

PRO. LOGIC
 REGULATOR
 H. P ASSY,
 To PRE. AMP assy CN3001 and TC.MAIN assy CN1001

MEZIXK/D1 TYPE ONLY

SCH-2F

A

B

C

D

E

F

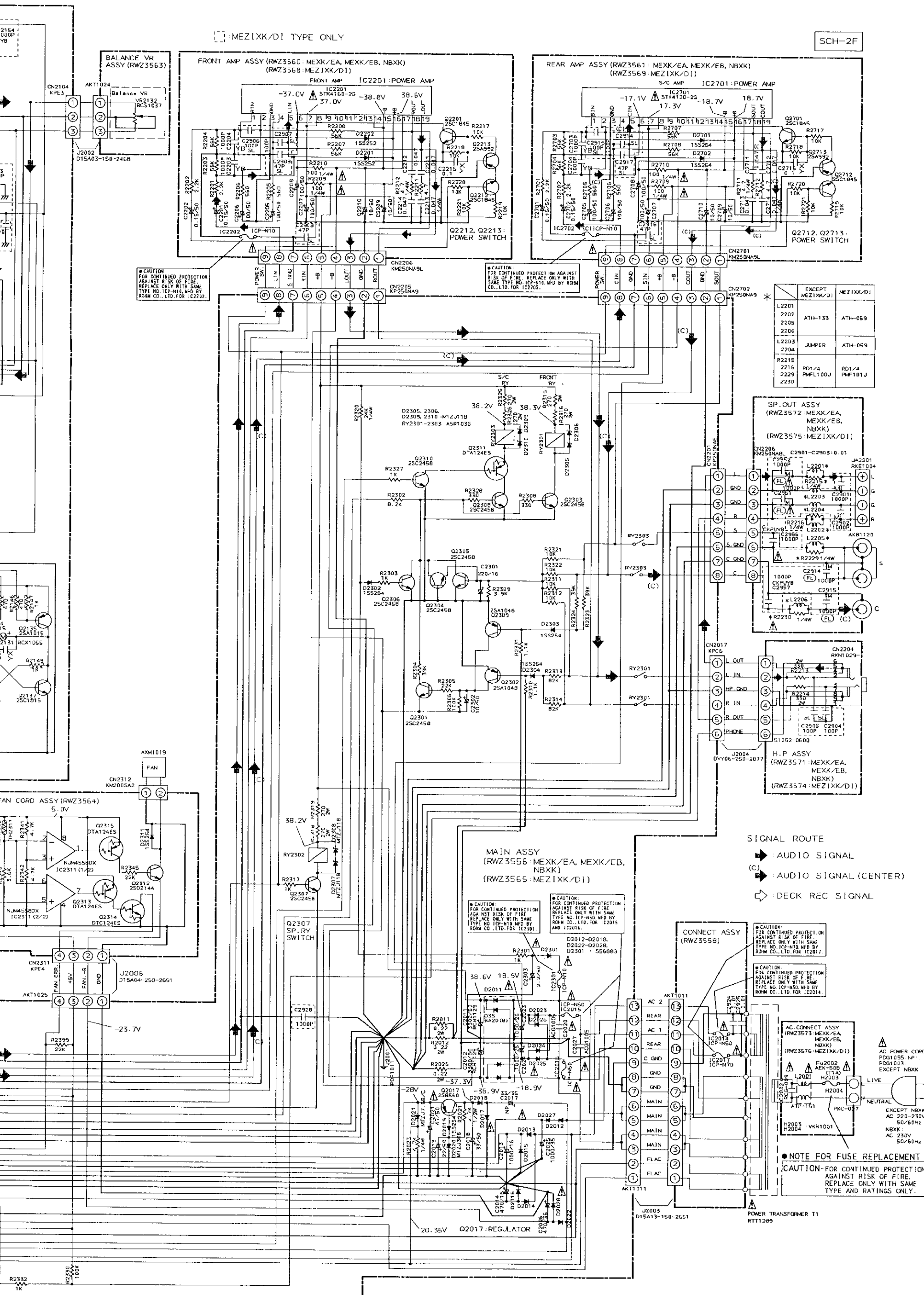

	EXCEPT MEZIXK/D1	MEZIXK/D1
L2201		
L2202	ATH-133	ATH-059
L2205		
L2206		
L2203	JUMPER	ATH-059
L2204		
R2215		
R2216	RD1/4	RD1/4
R2219	RMF-100J	RMF-101J
R2230		

SIGNAL ROUTE

- ➔ AUDIO SIGNAL
- (C) ➔ AUDIO SIGNAL (CENTER)
- ➔ DECK REC SIGNAL

CAUTION: FOR CONTINUED PROTECTION AGAINST RISK OF FIRE, REPLACE ONLY WITH SAME TYPE NO. ICP-N18, MFD BY ROHM CO., LTD. FOR IC2202.

CAUTION: FOR CONTINUED PROTECTION AGAINST RISK OF FIRE, REPLACE ONLY WITH SAME TYPE NO. ICP-N18, MFD BY ROHM CO., LTD. FOR IC2015 AND IC2014.

CAUTION: FOR CONTINUED PROTECTION AGAINST RISK OF FIRE, REPLACE ONLY WITH SAME TYPE NO. ICP-N18, MFD BY ROHM CO., LTD. FOR IC2017.

CAUTION: FOR CONTINUED PROTECTION AGAINST RISK OF FIRE, REPLACE ONLY WITH SAME TYPE AND RATINGS ONLY.

NOTE FOR FUSE REPLACEMENT
CAUTION- FOR CONTINUED PROTECTION AGAINST RISK OF FIRE, REPLACE ONLY WITH SAME TYPE AND RATINGS ONLY.

MAIN ASSY, SFC. VR ASSY, CONNECT ASSY, PRO. LOGIC ASSY, FRONT AMP ASSY, REAR AMP ASSY, REGULATOR ASSY, BALANCE VR ASSY, FAN CORD ASSY, H. P. ASSY, SP. OUT ASSY, AC. CONNECT ASSY

SCH-2F

3.3 DISPLAY ASSY

SCH-3F

DISPLAY ASSY (RWZ3570)

A

B

C

D

IC2502-IC2504:FL BPF NJM4558M

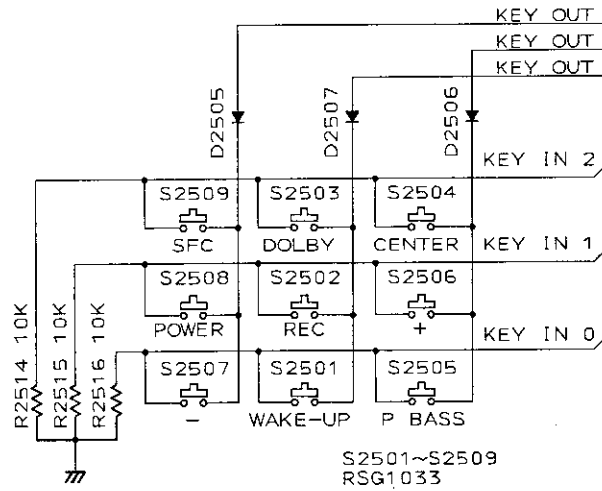
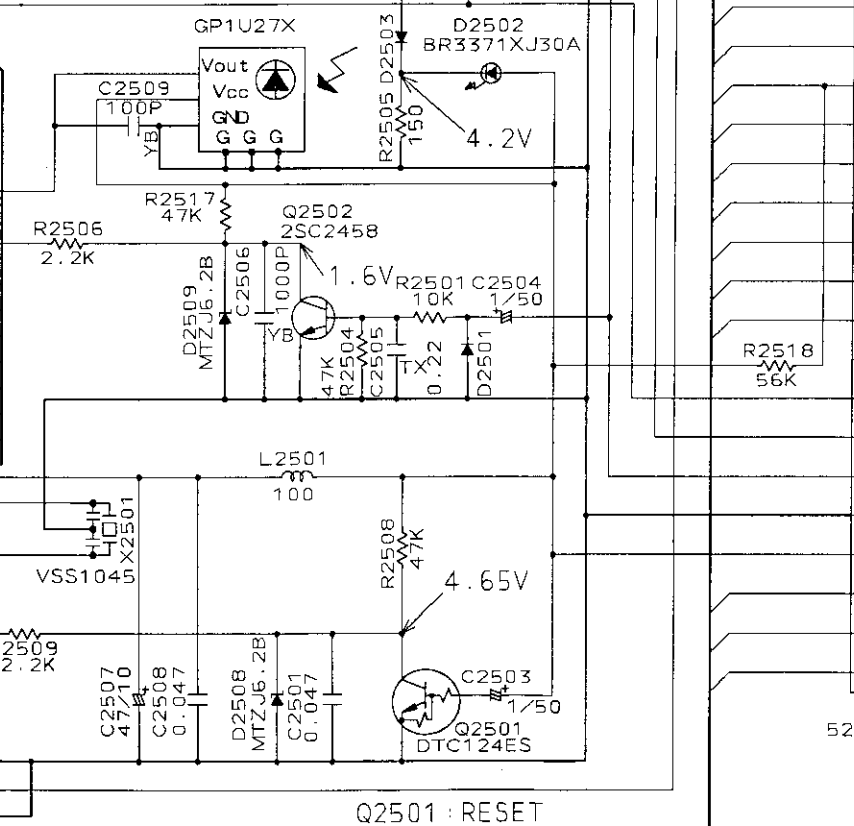
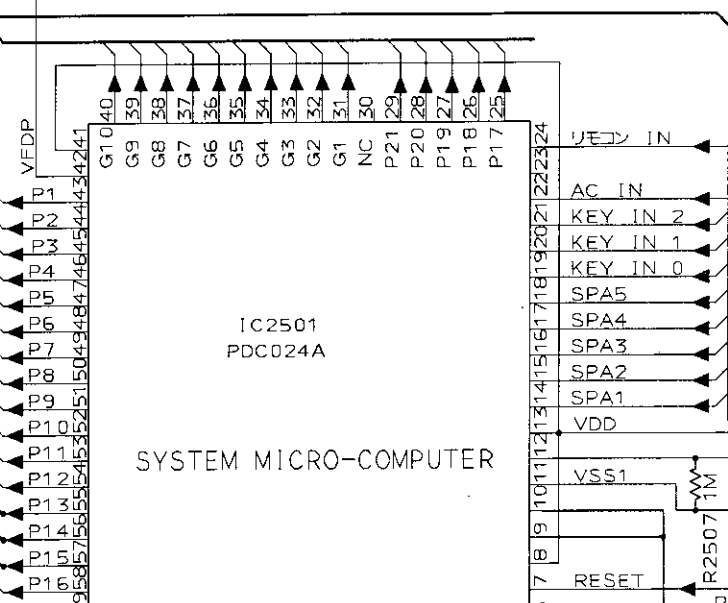
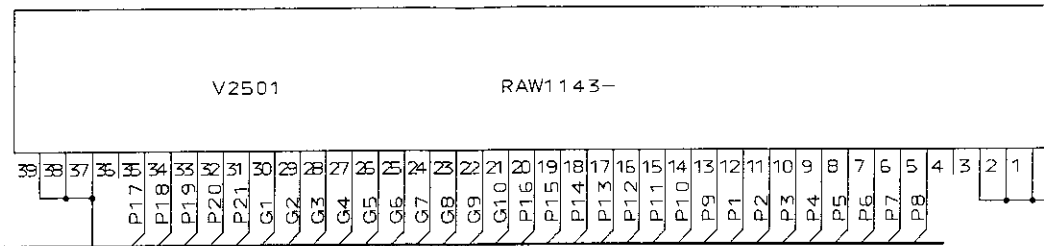
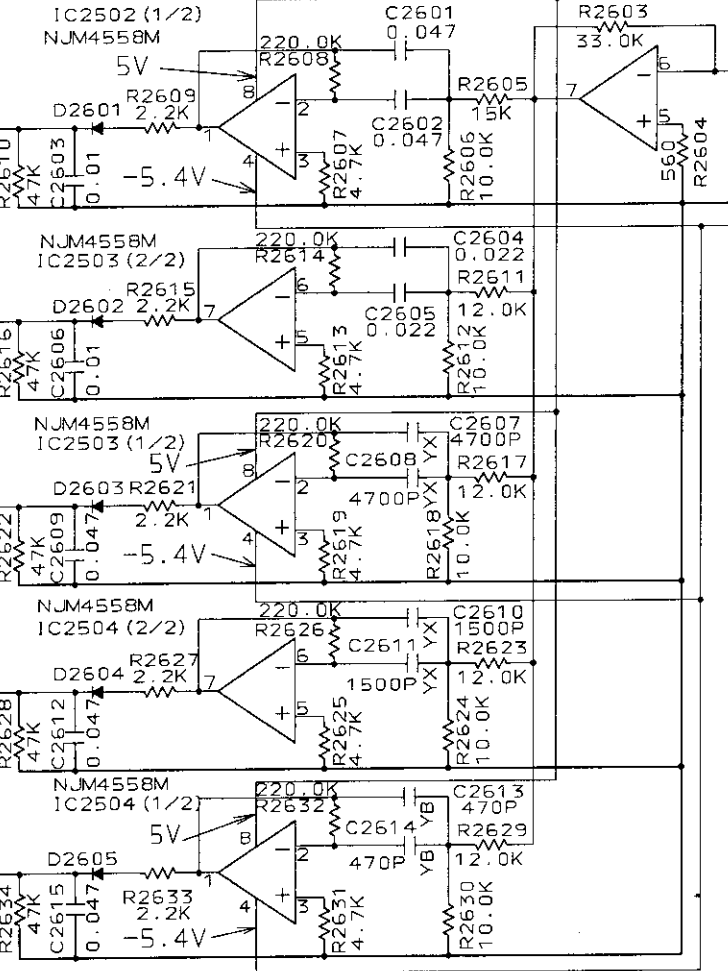

- ① +5V
- ② LR MIX
- ③ -5V
- ④ GND
- ⑤ CLK
- ⑥ STB
- ⑦ DATA
- ⑧ R/E1
- ⑨ S. CLK
- ⑩ S. DATA
- ⑪ R/E2
- ⑫ SW POWER
- ⑬ UP
- ⑭ SP. RY
- ⑮ DOWN
- ⑯ MUTE
- ⑰ NC
- ⑱ VFDP
- ⑲ FLAC2
- ⑳ FLAC1
- ㉑ GND
- ㉒ D. +5V
- ㉓ R/C RY
- ㉔ PHONE
- ㉕ ENEB

TO MAIN ASSY CN2012 (SCH-2F)

SCH-3F

SCH-3F

DISPLAY ASSY

DISPLAY ASSY

• This mou

DISPLAY ASSY (RWZ3570)

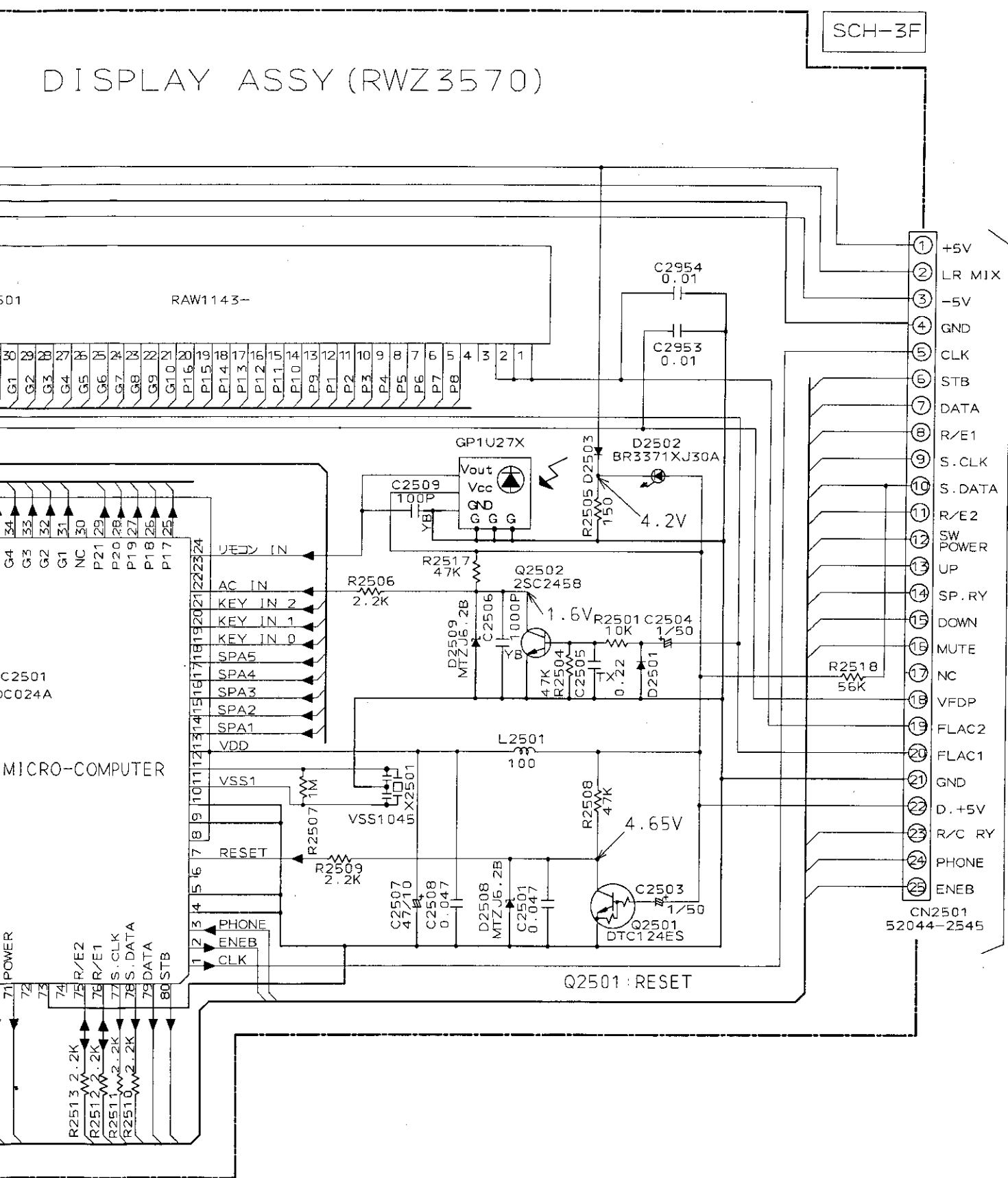

SCH-3F

SCH-3F

TO MAIN ASSY CN2012 (SCH-2F)

DISPLAY ASSY

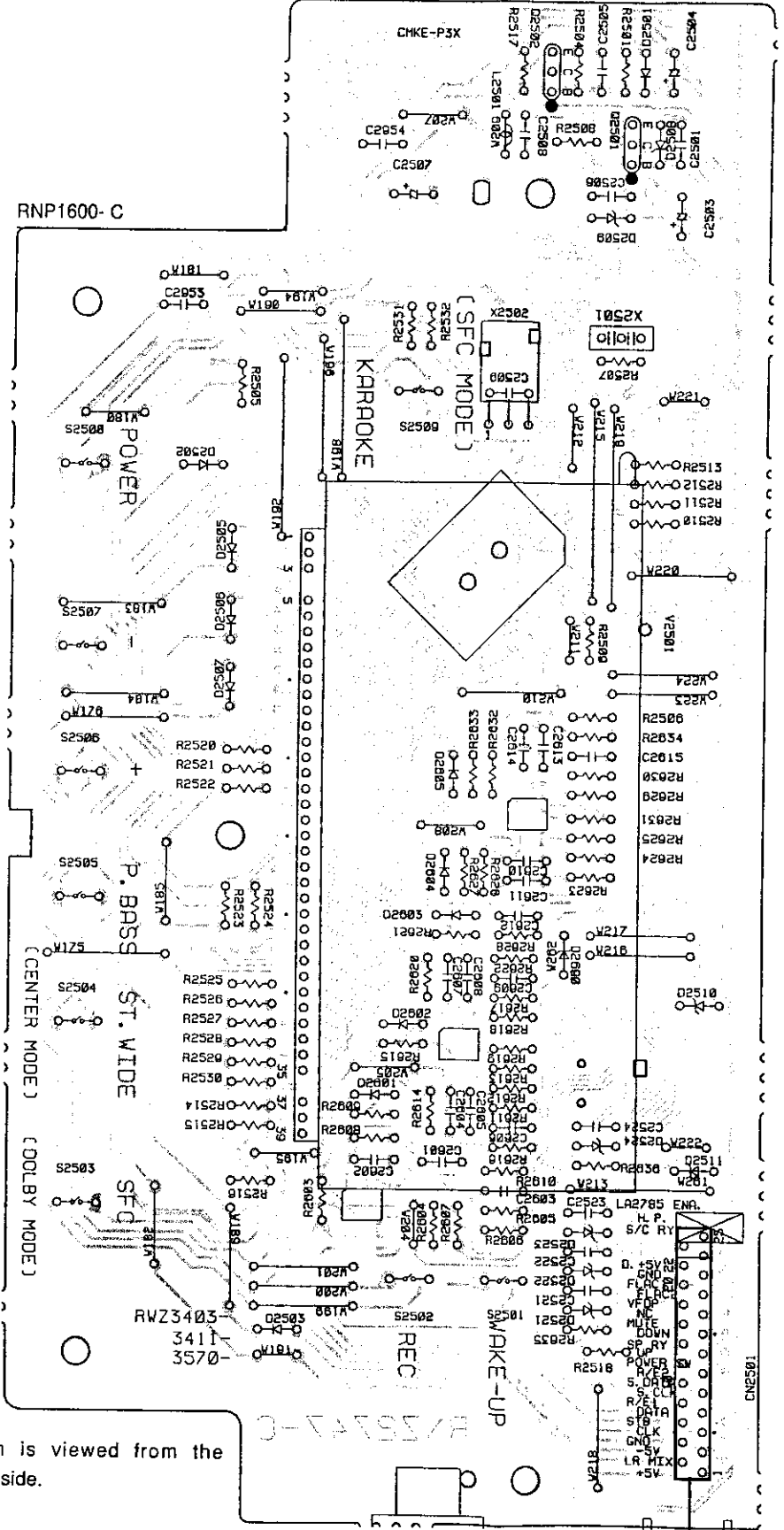

This diagram is viewed from the mounted parts side.

The parts mounted on this PCB include all necessary parts for several destinations. For further information for respective destinations, be sure to check with the schematic diagram.

To MAIN assy CN2012

Q2502

Q2501

IC2501

IC2504

IC2503

IC2502

A

B

C

D

DISPLAY ASSY

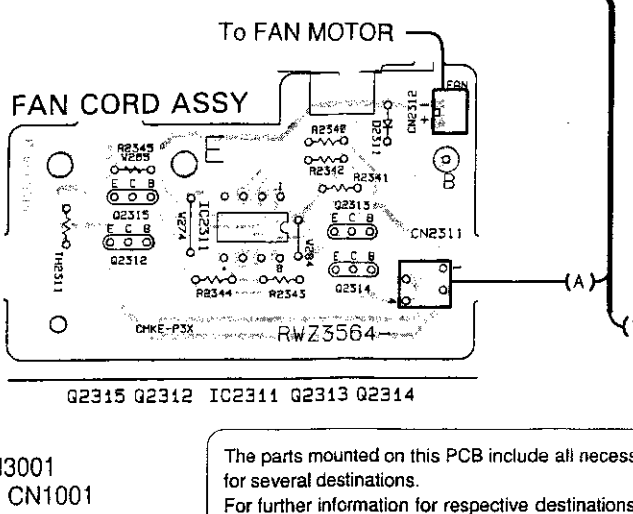
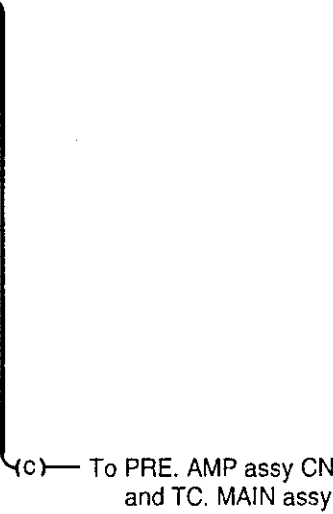
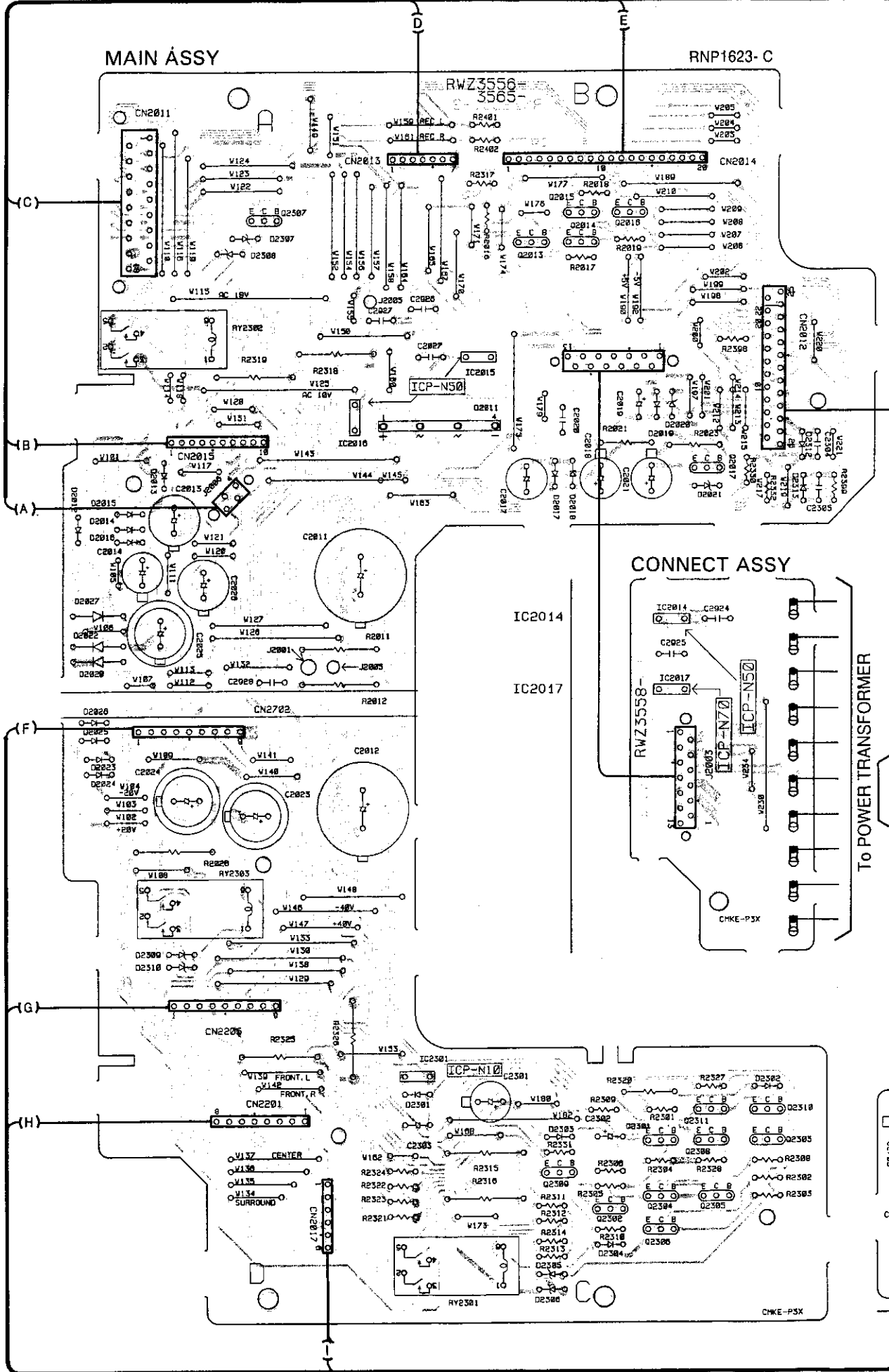

The parts mounted on this PCB include all necessary parts for several destinations. For further information for respective destinations, be sure to check with the schematic diagram.

To PRE. AMP assy CN3001 and TC. MAIN assy CN1001

To DISPLAY assy CN2501

To AC POWER CORD

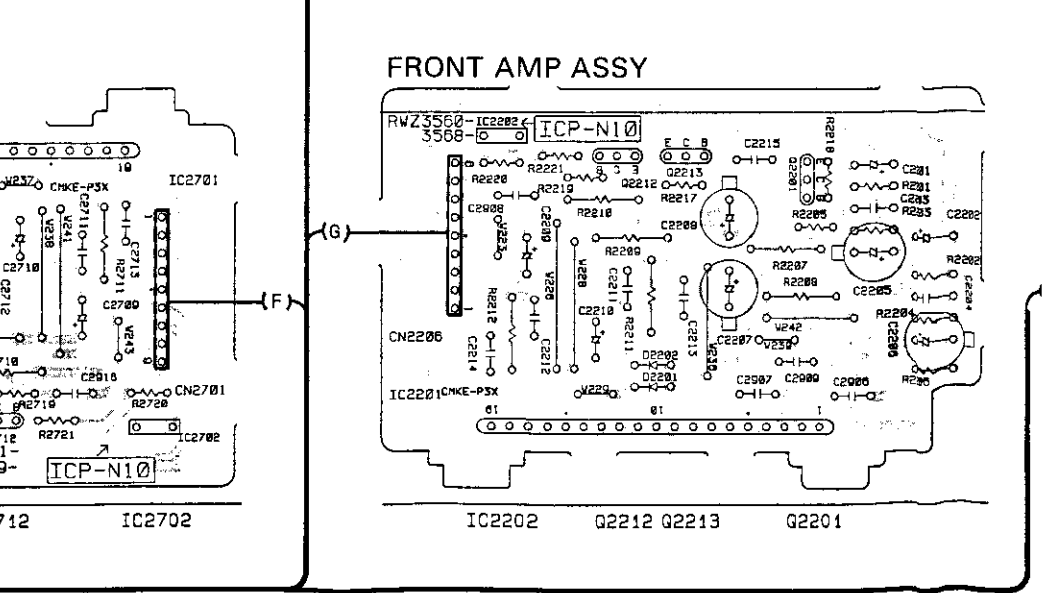
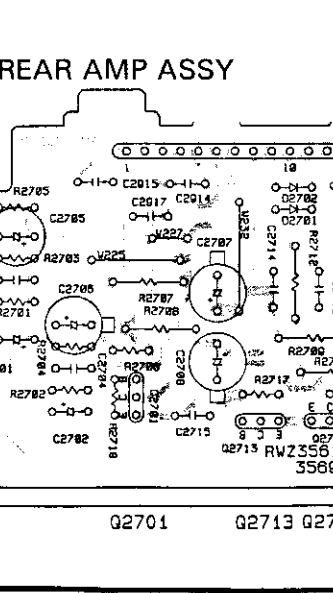
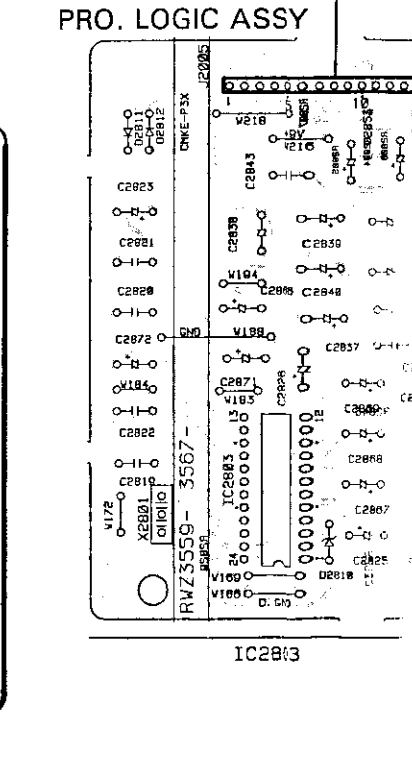
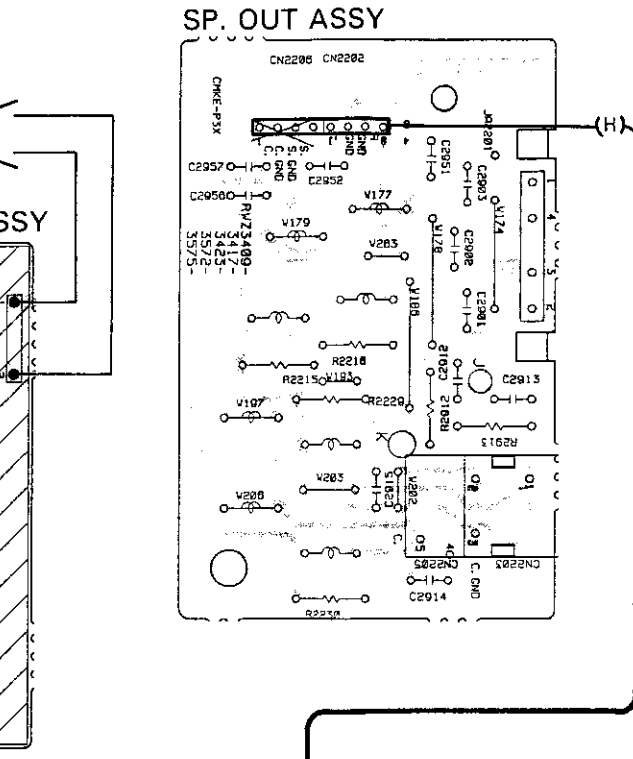
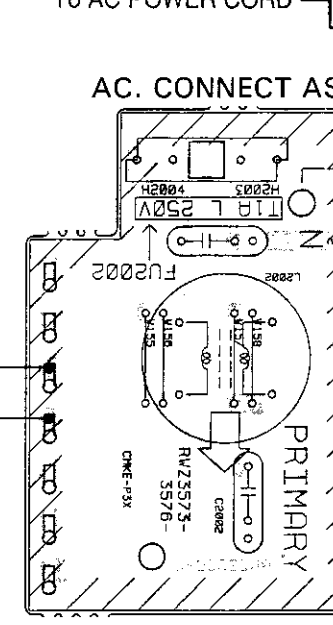

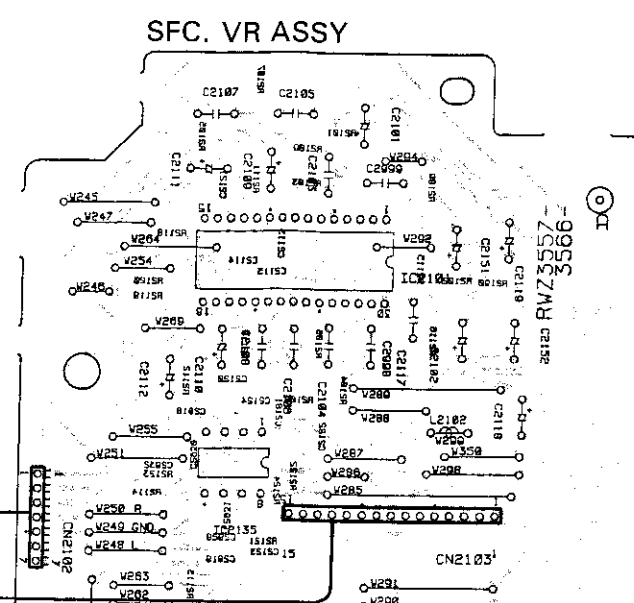
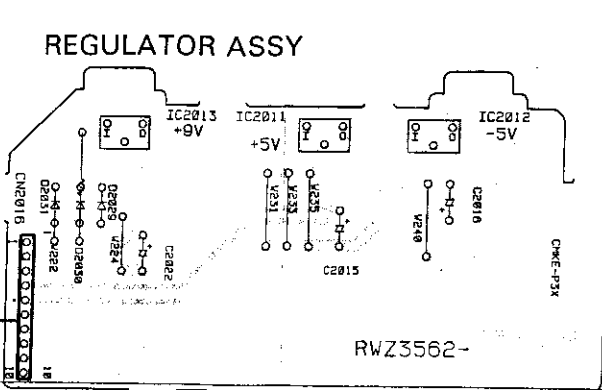
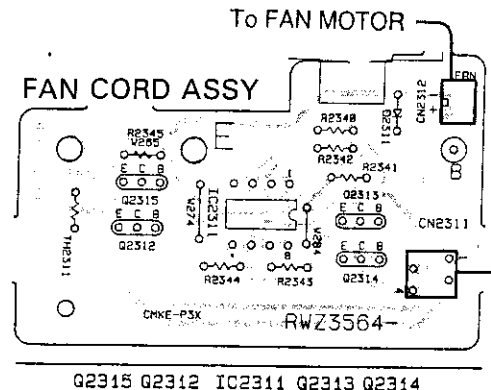
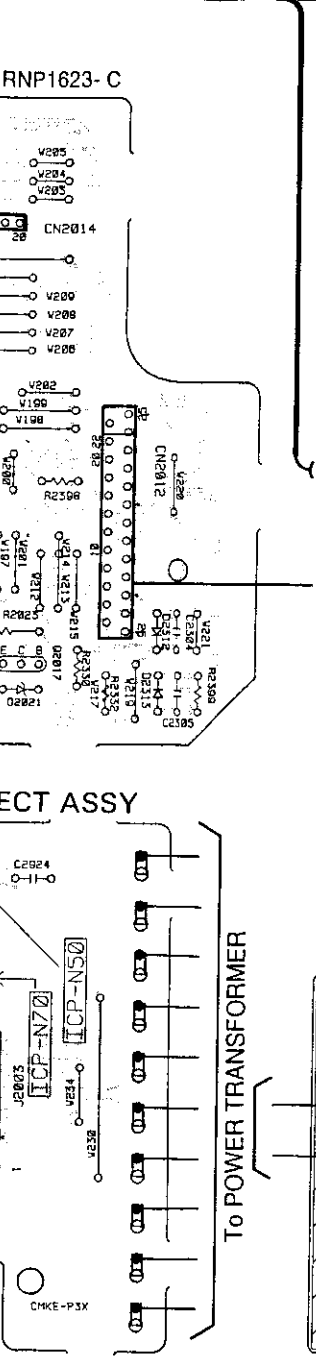

(C) To PRE. AMP assy CN3001 and TC. MAIN assy CN1001

To DISPLAY assy CN2501

The parts mounted on this PCB include all necessary parts for several destinations. For further information for respective destinations, be sure to check with the schematic diagram.

• This diagram is viewed from the mounted parts side.

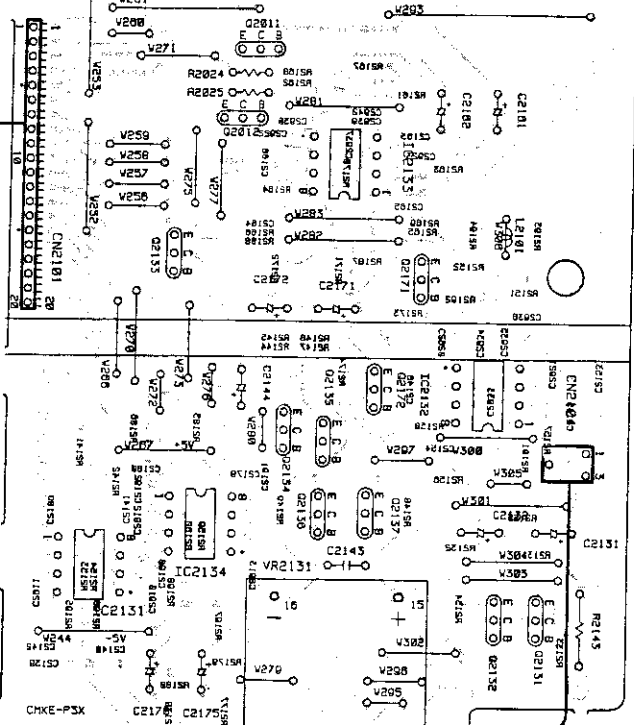
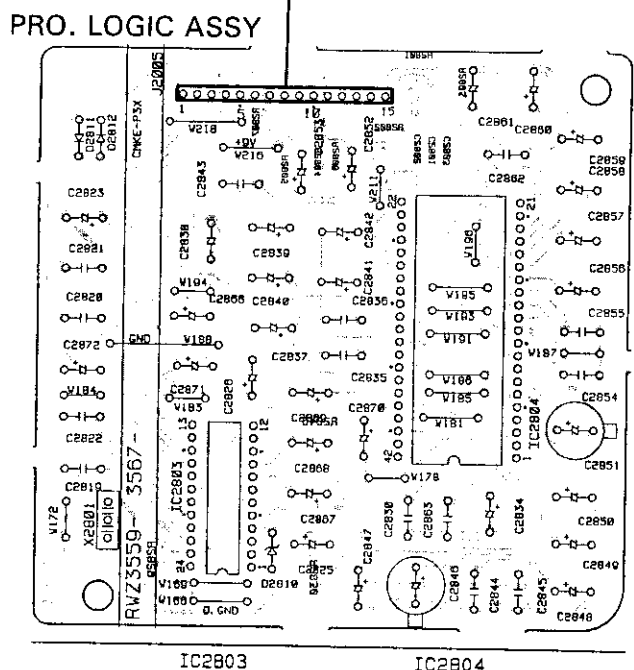
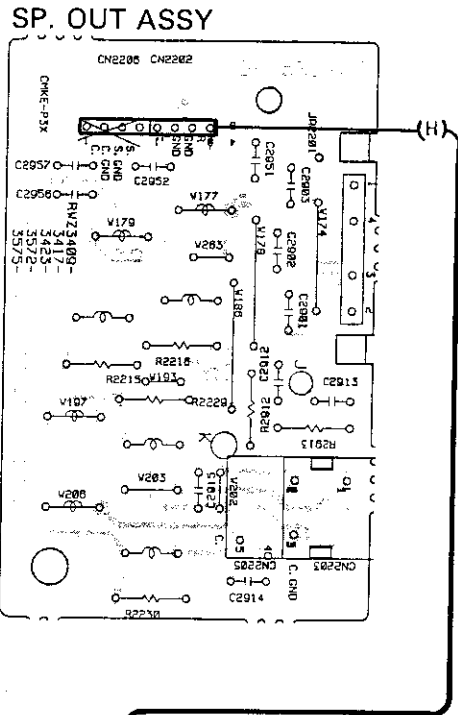
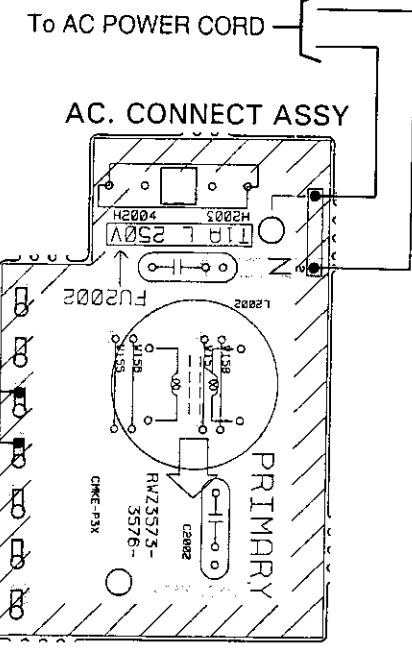

- IC2101
- IC2135
- Q2011
- Q2012
- IC2133
- Q2133
- Q2171
- IC2132
- Q2172
- Q2134
- Q2137
- IC2134
- IC2131
- Q2131
- Q2132
- VR2131

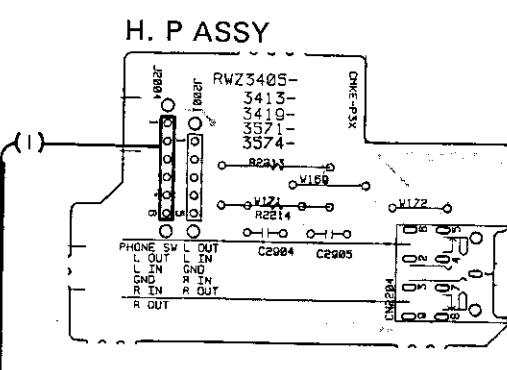
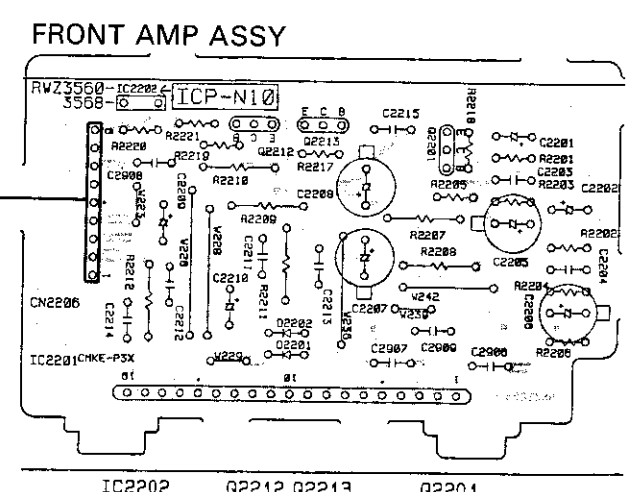
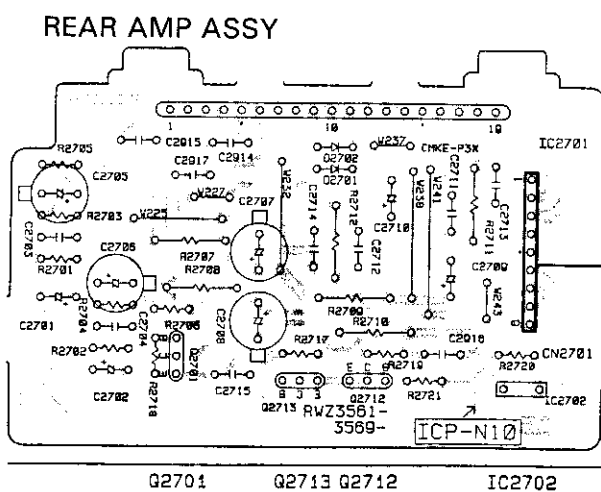
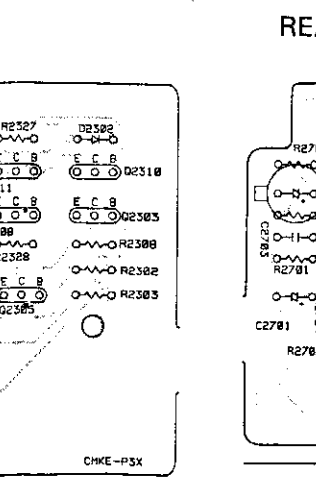

NOTE FOR PCB DIAGRAMS:
 1. Part numbers in PCB diagrams match those in the schematic diagrams.
 2. A comparison between the main parts of PCB and schematic diagrams is shown below.

Symbol in PCB Diagrams	Symbol in Schematic Diagrams	Part Name
		Transistor
		Transistor with resistor
		Field effect transistor
		Resistor array
		3-terminal regulator

4. BLOCK DIAGRAM

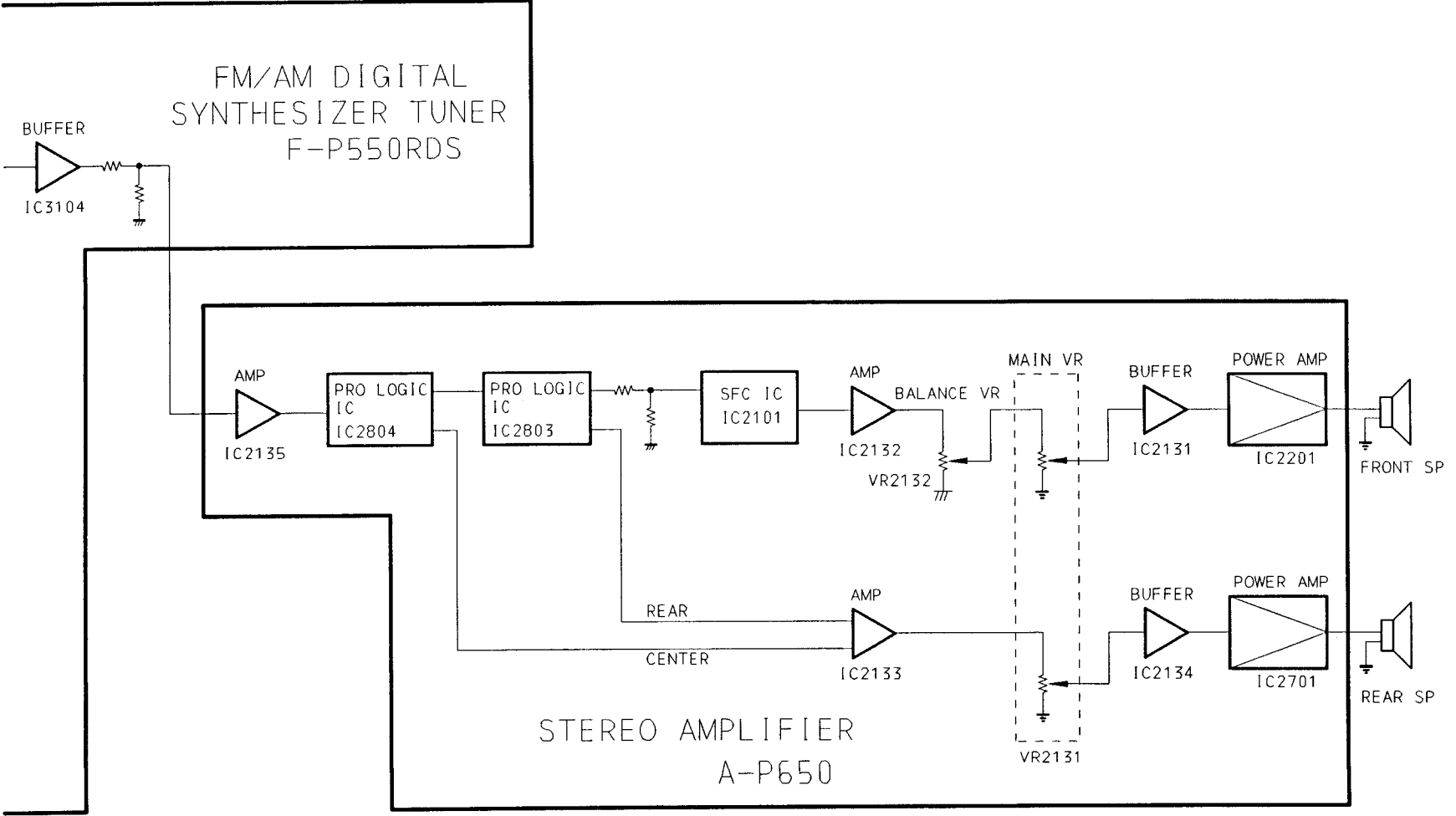

5. PCB PARTS LIST

NOTES :

- Parts marked by "NSP" are generally unavailable because they are not in our Master Spare Parts List.
- The Δ mark found on some component parts indicates the importance of the safety factor of the part. Therefore, when replacing, be sure to use parts of identical designation.
- Parts marked by "⊙" are not always kept in stock. Their delivery time may be longer than usual or they may be unavailable.
- When ordering resistors, first convert resistance values into code form as shown in the following examples.

Ex. 1 When there are 2 effective digits (any digit apart from 0), such as 560 ohm and 47k ohm (tolerance is shown by J = 5%, and K = 10%).

560Ω → 56 × 10¹ → 561 RD1/8PM $\begin{matrix} 5 & 6 & 1 \\ \square & \square & \square \end{matrix}$ J

47kΩ → 47 × 10³ → 473 RD1/4PS $\begin{matrix} 4 & 7 & 3 \\ \square & \square & \square \end{matrix}$ J

0.5Ω → 0R5 RN2H $\begin{matrix} 0 & R & 5 \\ \square & \square & \square \end{matrix}$ K

1Ω → 010 RS1P $\begin{matrix} 0 & 1 & 0 \\ \square & \square & \square \end{matrix}$ K

Ex. 2 When there are 3 effective digits (such as in high precision metal film resistors).

5.62kΩ → 562 × 10¹ → 5621 RM1/4PC $\begin{matrix} 5 & 6 & 2 & 1 \\ \square & \square & \square & \square \end{matrix}$ F

LIST OF WHOLE PCB ASSEMBLIES

Mark	Symbol & Description	Part No.				Remarks
		MEXK/EA	MEXK/EB	MEZIXK/DI	NBXX	
NSP	STEREO AMPLIFIER (A - P650)	RXF1036	RXF1039	RXF1037	RXF1035	
NSP	├ SFC. AMP assy	RWM1821	RWM1821	RWM1822	RWM1821	
	├├ MAIN assy	RWZ3556	RWZ3556	RWZ3565	RWZ3556	
	├├ SFC. VR assy	RWZ3557	RWZ3557	RWZ3566	RWZ3557	
NSP	├ CONNECT assy	RWZ3558	RWZ3558	RWZ3558	RWZ3558	
	├ PRO. LOGIC assy	RWZ3559	RWZ3559	RWZ3567	RWZ3559	*1
	├ FRONT AMP assy	RWZ3560	RWZ3560	RWZ3568	RWZ3560	
	├ REAR AMP assy	RWZ3561	RWZ3561	RWZ3569	RWZ3561	
	├ REGULATOR assy	RWZ3562	RWZ3562	RWZ3562	RWZ3562	
NSP	├ BALANCE VR assy	RWZ3563	RWZ3563	RWZ3563	RWZ3563	
NSP	├ FAN CORD assy	RWZ3564	RWZ3564	RWZ3564	RWZ3564	
NSP	├ DISPLAY assy	RWM1823	RWM1823	RWM1824	RWM1823	
	├├ DISPLAY assy	RWZ3570	RWZ3570	RWZ3570	RWZ3570	
NSP	├ H. P assy	RWZ3571	RWZ3571	RWZ3574	RWZ3571	
NSP	├ SP. OUT assy	RWZ3572	RWZ3572	RWZ3575	RWZ3572	
	├ AC. CONNECT assy	RWZ3573	RWZ3573	RWZ3576	RWZ3573	*2

Notes)

*1: Although RWZ3567 and RWZ3559 are different in part number, they consist of the same component.

*2: Although RWZ3576 and RWZ3573 are different in part number, they consist of the same component.

CONTRAST OF PCB ASSEMBLIES

SFC. VR Assy

RWZ3566 and RWZ3557 have the same construction except for the following :

Mark	Symbol & Description	Part No.		Remarks
		RWZ3557	RWZ3566	
	C2153, C2154, C2163, C2164, C2181, C2182, C2929 - C2940	Not used	CKSQYB102K50	*
	C2910 - C2913, C2918 - C2923	Not used	CCSQSL101J50	*
	C2998, C2999	Not used	CQMA102K50	*

Note *: Refer to "SCH-2F".

MAIN Assy

RWZ3565 and RWZ3556 have the same construction except for the following :

Mark	Symbol & Description	Part No.		Remarks
		RWZ3556	RWZ3565	
	C2928	Not used	CKCYB102K50	*

Note *: Refer to "SCH-2F".

FRONT AMP Assy

RWZ3568 and RWZ3560 have the same construction except for the following :

Mark	Symbol & Description	Part No.		Remarks
		RWZ3560	RWZ3568	
	C2906, C2907	Not used	CCCSL101J50	*
	C2908, C2909	Not used	CCCSL470J50	*

Note *: Refer to "SCH-2F".

REAR AMP Assy

RWZ3569 and RWZ3561 have the same construction except for the following :

Mark	Symbol & Description	Part No.		Remarks
		RWZ3561	RWZ3569	
	C2914, C2915	Not used	CCCSL101J50	*
	C2916, C2917	Not used	CCCSL470J50	*

Note *: Refer to "SCH-2F".

H. P Assy

RWZ3574 and RWZ3571 have the same construction except for the following :

Mark	Symbol & Description	Part No.		Remarks
		RWZ3571	RWZ3574	
	C2904, C2905	Not used	CCCSL101J50	*

Note *: Refer to "SCH-2F".

SP. OUT Assy

RWZ3575 and RWZ3572 have the same construction except for the following :

Mark	Symbol & Description	Part No.		Remarks
		RWZ3572	RWZ3575	
	L2201, L2202	ATH-133	ATH-059	*
	L2203, L2204	Not used	ATH-059	
	L2205, L2206	ATH-133	ATH-059	
	C2901, C2902, C2951, C2952	Not used	CQMA102J50	*
	C2914, C2915	Not used	CQMA102K50	*
	C2956, C2957	Not used	CKPUYB102K50	*
	R2215, R2216, R2229, R2230	RD1/4PMFL100J	RD1/4PMFL101J	

Note *: Refer to "SCH-2F".

PARTS LIST FOR MEXK/EA TYPE

Mark	No.	Description	Parts No.
MAIN ASSY			
SEMICONDUCTORS			
△	IC2301		ICP-N10
△	IC2015, IC2016		ICP-N50
	Q2302, Q2309		2SA1048
	Q2013		2SA1515
△	Q2017		2SB560
	Q2301, Q2303-Q2308, Q2310		2SC2458
	Q2014		2SC3377
	Q2016, Q2311		DTA124ES
	Q2015		DTC124ES
	D2019, D2302-D2304		1SS254
△	D2011		D3SBA20 (B)
	D2305-D2310		MTZJ11B
	D2020		MTZJ30B
	D2021		MTZJ7.5B
△	D2012-D2018, D2022-D2028, D2301		S5688G
SWITCHES AND RELAYS			
	RY2301-RY2303		ASR1035
CAPACITORS			
△	C2020, C2027 (0.01μF/150V)		ACG1005
	C2017		CEANP330M35
	C2302		CEAS100M50
	C2013		CEAS102M16
	C2023, C2024		CEAS102M25
	C2025		CEAS102M35
	C2019		CEAS220M50
	C2301		CEAS221M16
	C2303		CEAS2R2M50
	C2018		CEAS330M50
	C2021		CEAS470M50
	C2014		CEAS471M16
	C2026		CEAS471M35
	C2011, C2012 (3300μF/50V)		RCH1129
RESISTORS			
	R2021		RD1/2PM272J
	R2320		RD1/4PM243J
	R2023		RD1/4PM472J
	R2315, R2316, R2318, R2319		RS2LMF271J
	R2325, R2326		RS2LMF271J
	R2011, R2012, R2026		RS2LMFR22J
	Other Resistors		RD1/6PM□□□□
OTHERS			
	CN2012 25P FFC CONNECTOR		52045-2545
	CABLE HOLDER		AKT1011
	CN2015 10P PLUG		KM2001A10
	CN2014 20P PLUG		KM2001A20
	CN2013 7P PLUG		KM2001A7
	CN2201 8P SOCKET		KP250NA8
	CN2205, CN2702		KP250NA9
	9P SOCKET		
	CN2017 6P JUMPER CONNECTOR		KPC6
	CN2011 18P SOCKET		RKP1717

Mark	No.	Description	Parts No.
SFC. VR ASSY			
SEMICONDUCTORS			
	IC2131-IC2135		NJM4558D-D
	IC2101		PM0006A
	Q2134, Q2135		2SA1015
	Q2011		2SA1515
	Q2136, Q2137		2SC1815
	Q2131, Q2132, Q2171, Q2172		2SC2458
	Q2133		DTA124ES
	Q2012		DTC124ES
CAPACITORS			
	C2139, C2140		CCSQL220J50
	C2101, C2109, C2111, C2119		CEAS100M50
	C2151, C2152, C2161, C2162		CEAS100M50
	C2144		CEAS220M10
	C2131, C2132, C2137, C2138		CEAS2R2M50
	C2175, C2176		CEAS2R2M50
	C2102, C2110, C2112, C2118		CEJA100M50
	C2171, C2172		CEJA2R2M50
	C2143		CGCYX104M16
	C2123, C2124, C2145, C2146		CKSQYB221K50
	C2165, C2166		CKSQYB221K50
	C2135, C2136, C2173, C2174		CKSQYB393K50
	C2120, C2121		CKSQYB471K50
	C2113-C2115		CKSQYF104Z25
	C2141, C2142, C2179, C2180		CKSQYF473Z25
	C2106, C2108		CQMA102J50
	C2103, C2104		CQMA103J50
	C2117		CQMA562J50
	C2105, C2107		CQMA683J50
RESISTORS			
	VR2131 (100kΩ-B×4)		RCX1055
	R2143		RD1/4PM151J
	R2025		RD1/6PM102J
	R2024		RD1/6PM103J
	Other Resistors		RS1/10S□□□□
OTHERS			
	CN2103 15P JUMPER CONNECTOR		52147-1510
	CN2101 20P SOCKET		KP2001A20L
	CN2102 7P SOCKET		KP2001A7L
	CN2104 3P JUMPER CONNECTOR		KPE3
	PCB BINDER		VEF1008
CONNECT ASSY			
SEMICONDUCTORS			
△	IC2014		ICP-N50
△	IC2017		ICP-N70
CAPACITORS			
	C2924, C2925		CKCYF103Z50
OTHERS			
	CABLE HOLDER		AKT1011
PRO. LOGIC ASSY			
SEMICONDUCTORS			
	IC2804		LA2785
	IC2803		LV1010N
	D2811, D2812		1SS254
	D2810		MTZJ5.6B

Mark	No.	Description	Parts No.
CAPACITORS			
	C2801 - C2803		CCSQSL101J50
	C2842, C2861		CEANL3R3M50
	C2838, C2840, C2857, C2859		CEANL4R7M50
	C2823, C2867 - C2869		CEAS010M50
	C2826, C2847 - C2850		CEAS100M50
	C2866, C2870, C2872		CEAS101M10
	C2846, C2851, C2871		CEAS221M10
	C2825		CEAS2R2M50
	C2834		CEAS470M10
	C2841, C2860		CEASR15M50
	C2837, C2839, C2856, C2858		CEASR47M50
	C2852, C2853		CEJA100M50
	C2835, C2836, C2854, C2855		CFTYA104J50
	C2843, C2862		CFTYA154J50
	C2820, C2822		CFTYA333J50
	C2863		CFTYA474J50
	C2821		CQMA152J50
	C2844		CQMA223J50
	C2845		CQMA473J50
	C2830		CQMA681J50

RESISTORS			
	All Resistors		RS1/10S□□□J

OTHERS			
	X2801 (8.00MHz)		DSS1053

FRONT AMP ASSY

SEMICONDUCTORS			
△	IC2202	ICP - N10	
△	IC2201	STK4160 - 2G	
	Q2213	2SA992	
	Q2201, Q2212	2SC1845	
	D2201, D2202	1SS252	

CAPACITORS			
	C2209, C2210		CEAS100M50
	C2205 - C2208		CEAS101M50
	C2201, C2202		CEASR15M50
	C2215		CGCYX104M16
	C2203, C2204		CKCYB102K50
	C2211 - C2214		CKCYF473Z50

RESISTORS			
	R2211, R2212		RD1/4PM4R7J
△	R2209, R2210		RD1/4PMFL101J
	Other Resistors		RD1/6PM□□□J

OTHERS			
	CN2206 9P PLUG		KM250NA9L

REAR AMP ASSY

SEMICONDUCTORS			
△	IC2702	ICP - N10	
△	IC2701	STK4120 - 2G	
	Q2713	2SA992	
	Q2701, Q2712	2SC1845	
	D2701, D2702	1SS254	

Mark	No.	Description	Parts No.
CAPACITORS			
	C2709, C2710		CEAS100M50
	C2705 - C2708		CEAS101M50
	C2701, C2702		CEASR15M50
	C2715		CGCYX104M16
	C2703, C2704		CKCYB102K50
	C2711 - C2714		CKCYF473Z50

RESISTORS			
	R2711, R2712		RD1/4PM4R7J
△	R2709, R2710		RD1/4PMFL101J
	Other Resistors		RD1/6PM□□□J

OTHERS			
	CN2701 9P PLUG		KM250NA9L

REGULATOR ASSY

SEMICONDUCTORS			
△	IC2011		NJM78M05FA
△	IC2013		NJM78M09FA
△	IC2012		NJM79M05FA
△	D2029 - D2031		S5688G

CAPACITORS			
	C2015, C2016, C2022		CEAS220M16

OTHERS			
	CN2016 10P SOCKET		KP200IA10L

BALANCE VR ASSY

RESISTORS			
	VR2132 (250kΩ)		RCS107

FAN CORD ASSY

SEMICONDUCTORS			
	IC2311		NJM458D - D
	Q2312		2SD214S
	Q2313, Q2315		DTA12ES
	Q2314		DTC12ES
	D2311		1SS254

RESISTORS			
	All Resistors		RD1/6PM□□□J

OTHERS			
	CN2311 4P JUMPER CONNECTOR		KPE4
	CN2312 PLUG (2P)		KM200A2
	TH2311 THERMISTOR		REX105
	PCB BINDER		VEF108

DISPLAY ASSY

SEMICONDUCTORS			
	IC2502 - IC2504		NJM458M
	IC2501		PDC02A
	Q2502		2SC243
	Q2501		DTC12ES
	D2501, D2503, D2505 - D2507		1SS254
	D2601 - D2605		1SS254
	D2502		BR337KJ30A
	D2508, D2509		MTZJ62B

Mark	No.	Description	Parts No.
COILS AND FILTERS			
	L2501		LAU101J
SWITCHES AND RELAYS			
	S2501 - S2509		RSG1033
CAPACITORS			
	C2503, C2504		CEAS010M50
	C2507		CEAS470M10
	C2505		CFTXA224J50
	C2509		CKPUYB101K50
	C2506		CKPUYB102K50
	C2613, C2614		CKPUYB471K50
	C2603, C2606		CKPUYF103Z25
	C2953, C2954		CKPUYF103Z50
	C2604, C2605		CKPUYF223Z25
	C2501, C2508, C2601, C2602, C2609		CKPUYF473Z50
	C2612, C2615		CKPUYF473Z50
	C2610, C2611		CKPUYX152M16
	C2607, C2608		CKPUYX472M16
RESISTORS			
	All Resistors		RD1/6PM□□□J
OTHERS			
	CN2501	25P FFC CONNECTOR	52044 - 2545
		REMOTE RECEIVER UNIT	GP1U27X
	V2501	FL INDICATOR TUBE	RAW1143
	X2501	(6.00MHz)	VSS1045
H.P ASSY			
RESISTORS			
	R2213, R2214		RS2LMF331J
OTHERS			
		6P CABLE HOLDER	51052 - 0600
	CN2204	MINI JACK	RKN1029
SP. OUT ASSY			
COILS AND FILTERS			
	L2201, L2202, L2205, L2206	(1μH)	ATH - 133
RESISTORS			
	△ All Resistors		RD1/4PM□□□J
OTHERS			
		PIN JACK (3P)	AKB1120
	CN2206	8P PLUG	KM250NA8L
	JA2201	4P SPEAKER TERMINAL	RKE1004
AC. CONNECT ASSY			
COILS AND FILTERS			
	△ L2002		ATF - 151
CAPACITORS			
	△ C2002	(10000pF)	RCG - 009
OTHERS			
	H2003, H2004	FUSE HOLDER	VKR1001

6. IC INFORMATION

- The information shown in the list is basic information and may not correspond exactly to that shown in the schematic diagrams.

■ PDC024A (IC2501 : DISPLAY ASSY)

- System Control Micro-computer
- Pin Assignment (Top view)

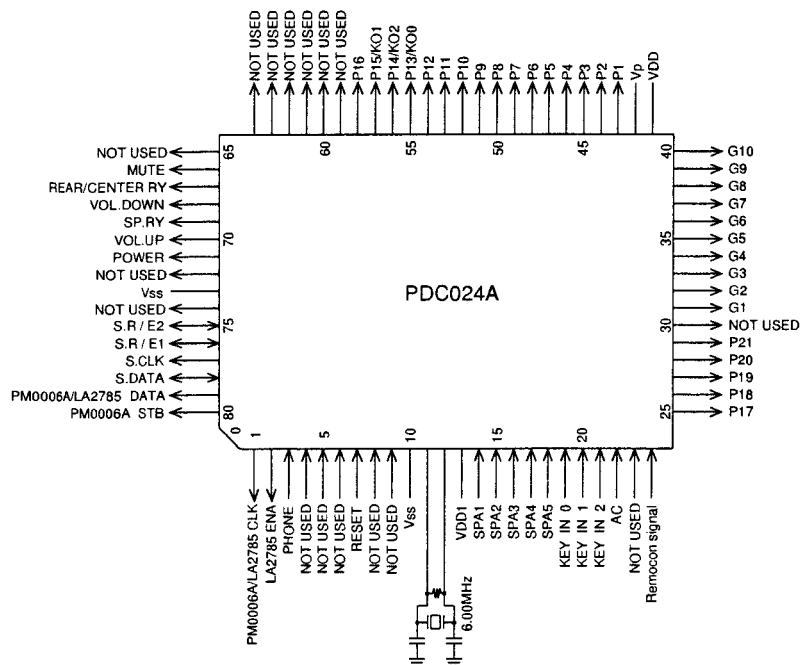

- Key Matrix

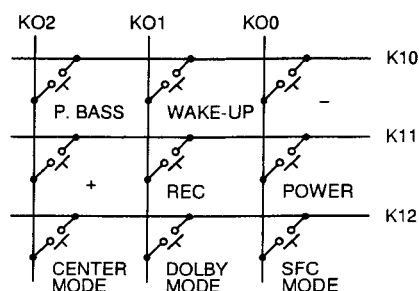

- Pin Function

No.	Pin Name	Pin Function	I/O	Description	Act.
1	P17/PWM0	PM0006A CLK	O	PM0006A/LA2785/LV1010N clock output	
2	P30	LA2785 ENA	O	LA2785/LV1010N enable output	H
3	P31	PHONE	I	Headphone IN input	L
4	P32	NOT USED	I	Connected to GND.	
5	P33				
6	P70/INT0	NOT USED	I	Not connect (internal pull-up)	
7	RES	RESET	I	Reset input	L
8	XT1/P74	NOT USED	I	Connected to VDD.	
9	XT2/P75	NOT USED	I	Connected to GND.	
10	Vss1	Vss	-		
11	CF1	-	O	Main system clock (6MHz) Connected to ceramic resonator.	
12	CF2				
13	VDD1	-	-	Connected to +5V.	

No.	Pin Name	Pin Function	I/O	Description	Act.
14	P80/AN0	SPA1	I	Spectrum analyzer input (analog) 10kHz	
15	P81/AN1	SPA2	I	Spectrum analyzer input (analog) 3.3kHz	
16	P82/AN2	SPA3	I	Spectrum analyzer input (analog) 1kHz	
17	P83/AN3	SPA4	I	Spectrum analyzer input (analog) 330Hz	
18	P84/AN4	SPA5	I	Spectrum analyzer input (analog) 100Hz	
19 21	P85/AN5 P87/AN7	KI0 KI2	I	Key scan • Key return signal input	
22	P71/INT1	AC	I	AC input	
23	P72/INT2/T0IN	NOT USED	I	Not connect (Pull-up at inside)	
24	P73/INT3/T0IN	Remocon signal	I	Remote control signal input	L
25 29	S0/T0 S4/T4	P17 P21	O	FL control segment output	
30	S5/T5	NOT USED	O	Not connect	
31 40	S6/T6 S15/T15	G1 G10	O	FL control digit output	
41	VDD2	VDD	-	Connected to +5V.	
42	VP	-	-	Connected to power supply (-30V) for FDP.	
43 50	S16/PC0 S23/PC7	P1 P8	O	FL control segment output	
51 54	S24/PD0 S27/PD3	P9 P12	O	FL control segment output	
55	S28/PD4	P13/KO0	O	FL control segment output/Key scan strobe output	
56	S29/PD5	P14/KO2			
57	S30/PD6	P15/KO1			
58	S31/PD7	P16	O	FL control segment output	
59 63	S32/PE0 S36/PE4	NOT USED	O	Not connect	
64	S37/PE5	NOT USED	O	Not connect	
65	PO0	NOT USED	O	Not connect	

No.	Pin Name	Pin Function	I/O	Description	Act.
66	PO1	MUTE	O	Line Mute output	H
67	PO2	REAR/CENTER	O	Rear/Center relay control output	H
68	PO3	VOL. DOWN	O	Motor volume control output (VOL DOWN)	L
69	PO4	SP. RY	O	Speaker relay control output	H
70	PO5	VOL. UP	O	Motor volume control output (VOL UP)	L
71	PO6	POWER	O	Power control output	H
72	PO7	NOT USED	O	Not connect	
73	Vss2	Vss	—	Connected to GND.	
74	P10/SO0	NOT USED	O	Not connect	
75	P11/SI0/SB0	S.R/E2	I/O	Communication request/enable input and output 2 for system bus communication	
76	P12/SCK0	S.R/E1	I/O	Communication request/enable input and output 1 for system bus communication	
77	P13/SO1	S. CLK	O	Clock input and output for system bus communication	
78	P14/SI1/SB1	S. DATA	I/O	Data input and output for system bus communication	
79	P15/SCK1	PM0006A DATA	O	PM0006A/LA2785/LV1010N data output	
80	P16/BUZ	PM0006A STB	O	PM0006A strobe output	H

■ LV1010N (IC2803: PRO. LOGIC ASSY)

- Dolby Surround Passive Decoder
- Block Diagram

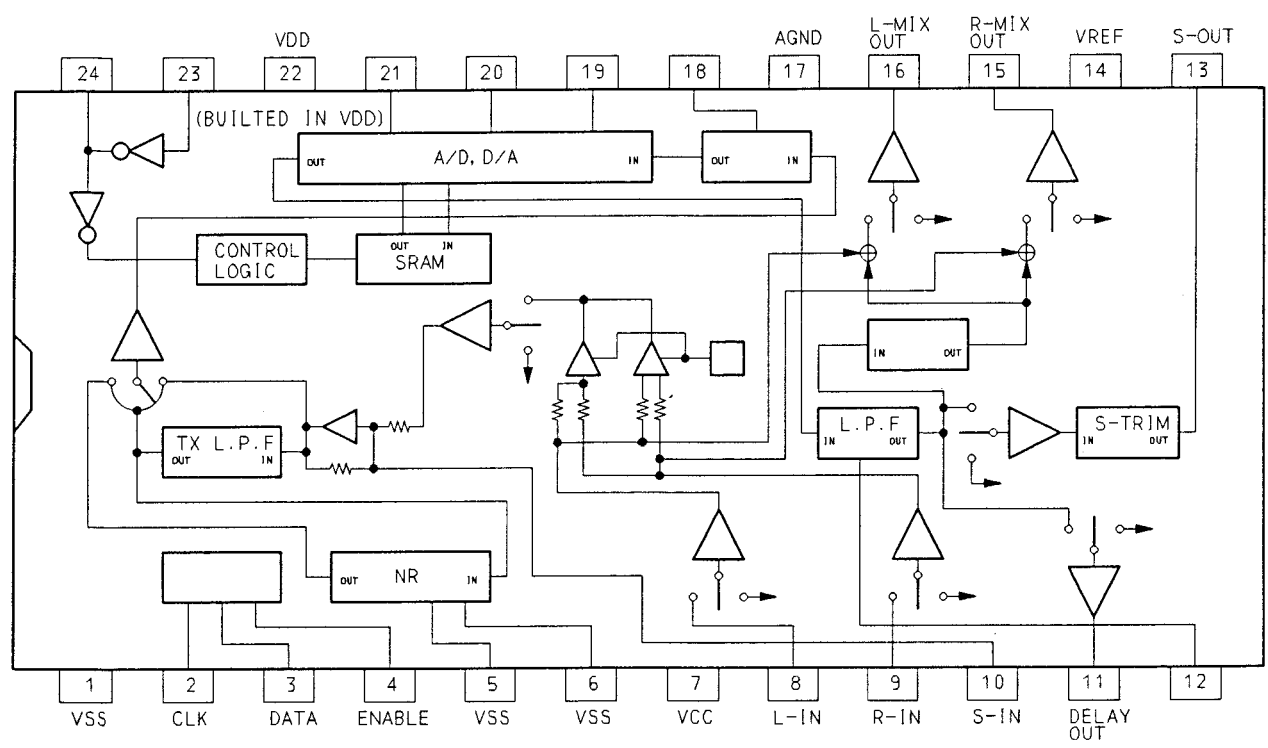

■ LA2785 (IC2804: PRO. LOGIC ASSY)

- Dolby Pro-logic Surround Matrix Decoder
- Block Diagram

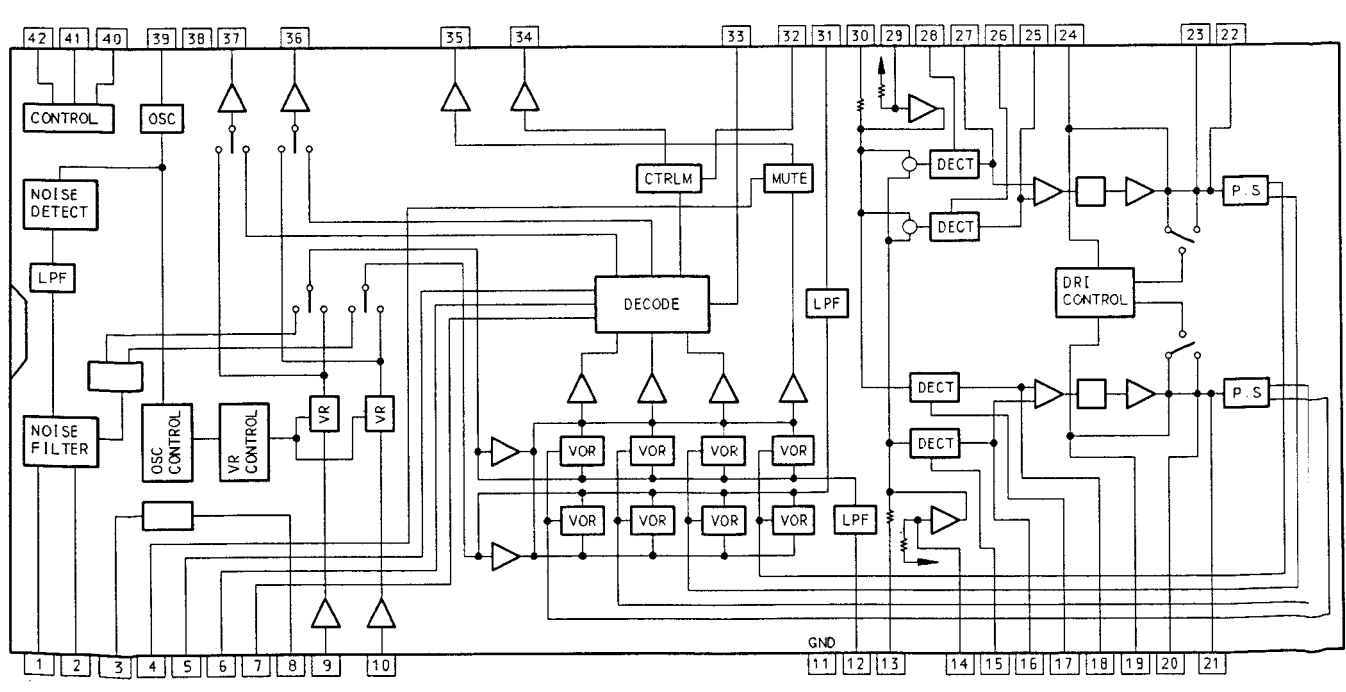

Service Manual

PIONEER®
The Art of Entertainment

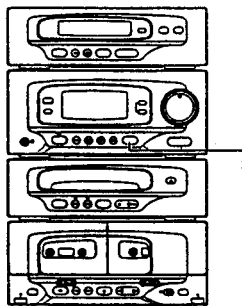

DEMO

ORDER NO.
RRV1256

SEPARATE MINI COMPONENT SYSTEM

XS-P550

THIS MANUAL IS APPLICABLE TO THE FOLLOWING MODEL(S) AND TYPE(S).

Type	Model	Power Requirement	Remarks
	XS-P550		
MEXK/EA	○	AC220-230V	
MEXK/EB	○	AC220-230V	
MEZIXK/DI	○	AC220-230V	
NBXX	○	AC230V	

● XS-P550 is a combination of the following components.

STEREO AMPLIFIER : A-P550
 FM/AM DIGITAL SYNTHESIZER TUNER : F-P550RDS
 COMPACT DISC PLAYER : PD-P550
 STEREO DOUBLE CASSETTE DECK : CT-P550WR

● This product does not function properly when independent; to avoid malfunctions, be sure to connect it to the prescribed system component(s), otherwise damage may result.

CONTENTS

1. SAFETY INFORMATION	2	6. SINGLE OPERATION METHOD	69
2. EXPLODED VIEWS, PACKING AND PARTS LIST	4	7. ADJUSTMENTS	70
3. BLOCK DIAGRAM	20	8. IC INFORMATION	86
4. SCHEMATIC AND PCB CONNECTION DIAGRAMS	21	9. FL INFORMATION	99
5. PCB PARTS LIST	61	10. DISASSEMBLY	101
		11. PANEL FACILITIES	102
		12. SPECIFICATIONS	104

PIONEER ELECTRONIC CORPORATION 4-1, Meguro 1-Chome, Meguro-ku, Tokyo 153, Japan
PIONEER ELECTRONICS SERVICE INC. P.O. Box 1760, Long Beach, California 90801, U.S.A.
PIONEER ELECTRONICS OF CANADA, INC. 300 Allstate Parkway Markham, Ontario L3R 0P2, Canada
PIONEER ELECTRONIC [EUROPE] N.V. Haven 1087 Keetberglaan 1, 9120 Melsele, Belgium
PIONEER ELECTRONICS AUSTRALIA PTY. LTD. 178-184 Boundary Road, Braeside, Victoria 3195, Australia, TEL: [03] 580-9911
 © **PIONEER ELECTRONIC CORPORATION 1995**

T-DFY MAR. 1995 Printed in Japan

1. SAFETY INFORMATION



This service manual is intended for qualified service technicians; it is not meant for the casual do-it-yourselfer. Qualified technicians have the necessary test equipment and tools, and have been trained to properly and safely repair complex products such as those covered by this manual. Improperly performed repairs can adversely affect the safety and reliability of the product and may void the warranty. If you are not qualified to perform the repair of this product properly and safely, you should not risk trying to do so and refer the repair to a qualified service technician.

WARNING

Lead in solder used in this product is listed by the California Health and Welfare agency as a known reproductive toxicant which may cause birth defects or other reproductive harm (California Health & Safety Code, Section 25249.5). When servicing or handling circuit boards and other components which contain lead in solder, avoid unprotected skin contact with the solder. Also, when soldering do not inhale any smoke or fumes produced.



NOTICE

(FOR CANADIAN MODEL ONLY)

Fuse symbols  (fast operating fuse) and/or  (slow operating fuse) on PCB indicate that replacement parts must be of identical designation.

REMARQUE

(POUR MODÈLE CANADIEN SEULEMENT)

Les symboles de fusible  (fusible de type rapide) et/ou  (fusible de type lent) sur CCI indiquent que les pièces de remplacement doivent avoir la même désignation.

(FOR USA MODEL ONLY)

1. SAFETY PRECAUTIONS

The following check should be performed for the continued protection of the customer and service technician.

LEAKAGE CURRENT CHECK

Measure leakage current to a known earth ground (water pipe, conduit, etc.) by connecting a leakage current tester such as Simpson Model 229-2 or equivalent between the earth ground and all exposed metal parts of the appliance (input/output terminals, screwheads, metal overlays, control shaft, etc.). Plug the AC line cord of the appliance directly into a 120V AC 60 Hz outlet and turn the AC power switch on. Any current measured must not exceed 0.5 mA.

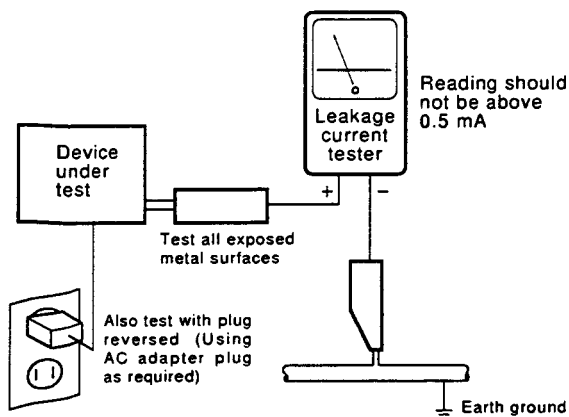

AC Leakage Test

ANY MEASUREMENTS NOT WITHIN THE LIMITS OUTLINED ABOVE ARE INDICATIVE OF A POTENTIAL SHOCK HAZARD AND MUST BE CORRECTED BEFORE RETURNING THE APPLIANCE TO THE CUSTOMER.

2. PRODUCT SAFETY NOTICE

Many electrical and mechanical parts in the appliance have special safety related characteristics. These are often not evident from visual inspection nor the protection afforded by them necessarily can be obtained by using replacement components rated for voltage, wattage, etc. Replacement parts which have these special safety characteristics are identified in this Service Manual.

Electrical components having such features are identified by marking with a Δ on the schematics and on the parts list in this Service Manual.

The use of a substitute replacement component which does not have the same safety characteristics as the PIONEER recommended replacement one, shown in the parts list in this Service Manual, may create shock, fire, or other hazards.

Product Safety is continuously under review and new instructions are issued from time to time. For the latest information, always consult the current PIONEER Service Manual. A subscription to, or additional copies of, PIONEER Service Manual may be obtained at a nominal charge from PIONEER.

(FOR EUROPEAN MODEL ONLY)

VARO!

AVATTAESSA JA SUOJALUKITUS OHITETTAESSA OLET ALTTIINA NÄKYMÄTTÖMÄLLE LASERSÄTEILYLLE. ÄLÄ KATSO SÄTEESEEN.

ADVERSEL:

USYNLIG LASERSTRÅLING VED ÅBNING NÅR SIKKERHEDSAFBRYDERE ER UDE AF FUNKTION UNGDÅ UDSÆTTELSE FOR STRÅLING.

VARNING !

OSYNLIG LASERSTRÅLING NÅR DENNA DEL ÄR ÖPPNAD OCH SPÄRREN ÄR URKOPPLAD. BETRakta EJ STRÅLEN.



LASER
Kuva 1
Lasersäteilyn
varoituserkki

WARNING !

DEVICE INCLUDES LASER DIODE WHICH EMITS INVISIBLE INFRARED RADIATION WHICH IS DANGEROUS TO EYES. THERE IS A WARNING SIGN ACCORDING TO PICTURE 1 INSIDE THE DEVICE CLOSE TO THE LASER DIODE.



LASER
Picture 1
Warning sign for
laser radiation

IMPORTANT

THIS PIONEER APPARATUS CONTAINS LASER OF CLASS 1. SERVICING OPERATION OF THE APPARATUS SHOULD BE DONE BY A SPECIALLY INSTRUMENTED PERSON.

LASER DIODE CHARACTERISTICS

MAXIMUM OUTPUT POWER: 5 mw
WAVELENGTH: 780 - 785 nm

LABEL CHECK (PD - P550)

MEXK/EA, MEXK/EB,
NBXK and MEZIXK/DI
types



NBXK type



MEXK/EA, MEXK/EB and
MEZIXK/DI types

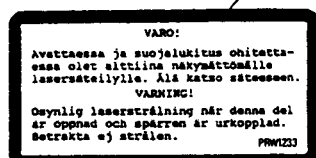
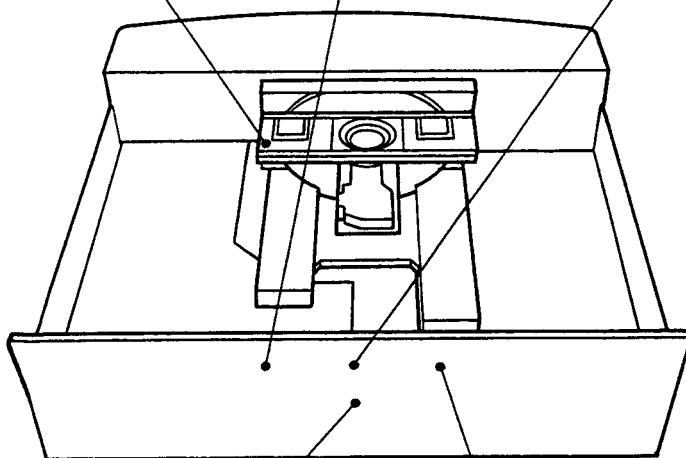

MEXK/EA, MEXK/EB and
MEZIXK/DI types



MEXK/EA, MEXK/EB, NBXK and
MEZIXK/DI types

Additional Laser Caution

1. Laser Interlock Mechanism

The position of the switch (S601) for detecting loading completion is detected by the system microprocessor, and the design prevents laser diode oscillation when the switch (S601) is not in CLMP terminal side (when the mechanism is not clamped and CLMP signal is high level.) Thus, the interlock will no longer function if the switch (S601) is deliberately set to CLMP terminal side (if CLMP signal is low level).

In the test mode* the interlock mechanism will not function.

Laser diode oscillation will continue, if pin 1 of M51593FP (IC101) on the PRE-AMP BOARD ASSY loaded on the pickup assembly are connected to GND, or pin 19 is connected to low level (ON), or else the terminals of Q101 are shorted to each other (fault condition).

2. When the cover is opened, close viewing of the objective lens with the naked eye will cause exposure to a Class 1 laser beam.

* Refer to page 78.

2. EXPLODED VIEWS, PACKING AND PARTS LIST

NOTES :

- Parts marked by "NSP" are generally unavailable because they are not in our Master Spare Parts List.
- The Δ mark found on some component parts indicates the importance of the safety factor of the part. Therefore, when replacing, be sure to use parts of identical designation.
- Parts marked by "☉" are not always kept in stock. Their delivery time may be longer than usual or they may be unavailable.

2.1 PACKING

Mark	No.	Description	Parts No.	Mark	No.	Description	Parts No.
	1	PROTECTOR F	RHA1162		12	OPERATING INSTRUCTIONS (German/Italian) (MEXK/EA and MEZIXK/DI types)	RRD1162
	2	PROTECTOR R	RHA1163		12	OPERATING INSTRUCTIONS (English) (MEXK/EB and NBXK types)	RRB1153
	3	PROTECTOR F	RHA1164		13	OPERATING INSTRUCTIONS (French/Dutch) (MEXK/EA type)	RRD1163
	4	PROTECTOR R	RHA1165		13	OPERATING INSTRUCTIONS (French/Swedish/Spanish/Portuguese) (MEXK/EB type)	RRD1164
	5	MASTER CARTON	RHG1625	NSP	14	BATTERY (R03, AAA)	VEM-022
	6	SHEET	VHL1006		15	POLY. BAG (0.03 × 230 × 340)	Z21-038
	7	FM ANTENNA ASSY	ADH1019				
	8	LOOP ANTENNA ASSY	ATB1012				
	9	REMOTE CONTROL UNIT (CU-XR015)	AXD7030				
	10	BATTERY COVER	AZA7050				
	11	CONTROL CORD ASSY	RDE1041				

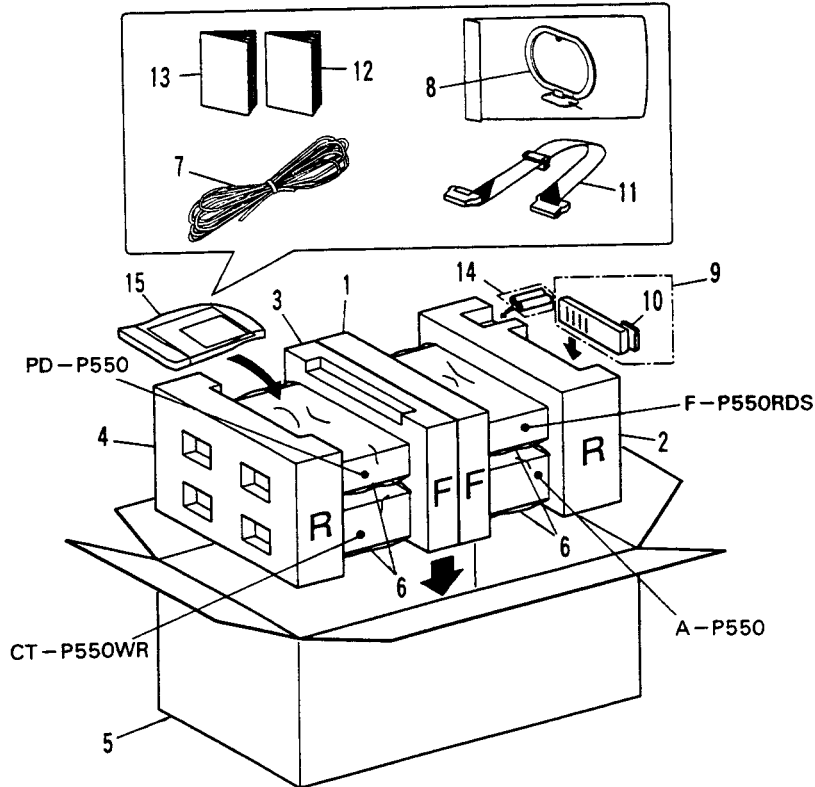

2.2 EXPLODED VIEWS

1. FM/AM DIGITAL SYNTHESIZER TUNER (F-P550RDS)

Mark	No.	Description	Parts No.
	1	FM/AM TUNER MOD. (RDS)/HE (MEXK/EA, MEXK/EB and NBXK types)	AXQ7013
A	1	FM/AM TUNER MOD. (RDS)/HEZ (MEZIXK/DI type)	AXQ7014
	2	PRE. AMP ASSY (MEXK/EA, MEXK/EB and NBXK types)	RWZ3426
	2	PRE. AMP ASSY (MEZIXK/DI type)	RWZ3428
	3	DISPLAY ASSY	RWZ3427
NSP	4	CONTROL CORD ASSY	RDE1042
NSP	5	CUSHION A	REB1283
NSP	6	UNDER BASE	RNB1107
NSP	7	INSULATOR ASSY	RXA1673
NSP	8	PC SUPORT	VEC1549
	9	TU CONTROL BUTTON	RAC1955
	10	TU FRONT PANEL	RAH2501
	11	TU DISPLAY WINDOW	RAH2496
NSP	12	BONNET	REA1182
B NSP	13	REAR BASE AEMXK (MEXK/EA, MEXK/EB and NBXK types)	RNA1878
	13	REAR BASE AEMZIXK (MEZIXK/DI type)	RNA1879
	14	TU BUTTON	REA1183
	15	SCREW	BBZ30P080FZK
	16	SCREW	PPZ30P080FMC
	17	SCREW (MEZIXK/DI type only)	ABA1047
	18	CERAMIC CAPACITOR (MEZIXK/DI type only)	CKDYB152K50
	19	SCREW	VBZ35P080FZK

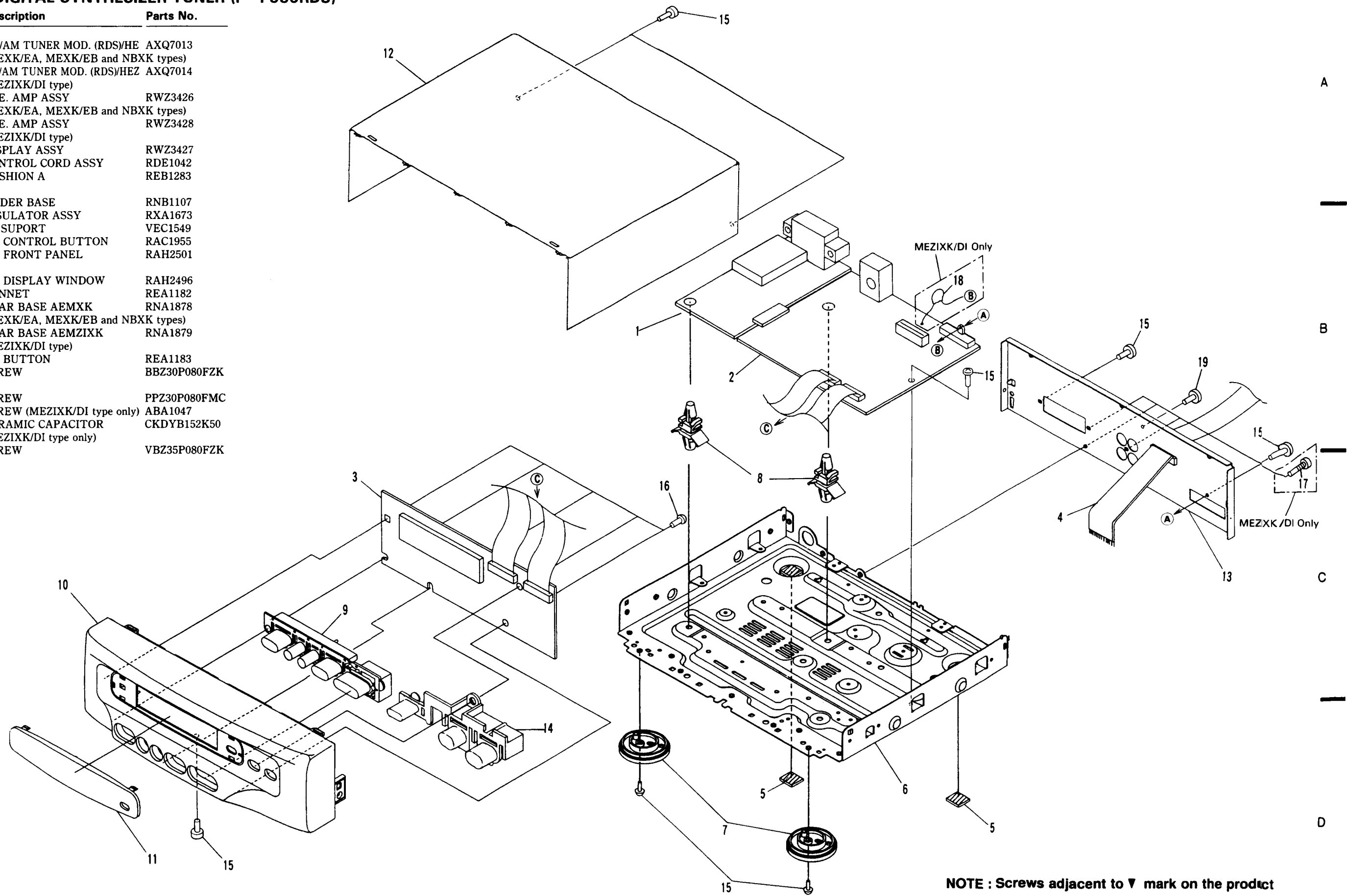

NOTE : Screws adjacent to ▼ mark on the product are used for disassembly.

2. STEREO DOUBLE CASSETTE DECK (CT-P550WR)

■ Exterior

A

A

B

B

C

C

D

D

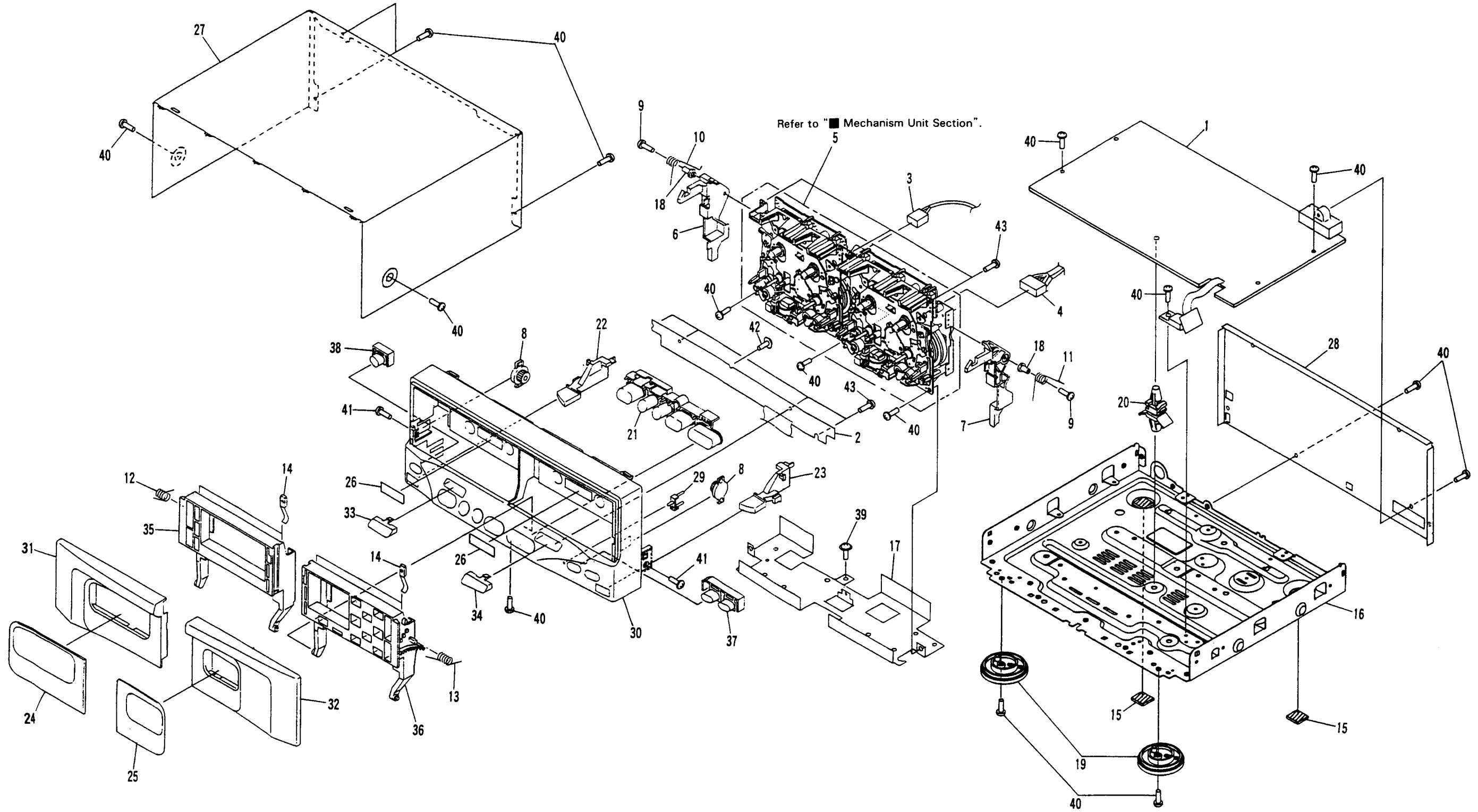

Mark	No.	Description	Parts No.
NSP	1	TC. MAIN ASSY	RWZ3440
	2	TC. FUNC ASSY	RWZ3441
	3	CONNECTOR ASSY 3P	RKP1716
	4	CONNECTOR ASSY 5P	RKP1715
	5	MECHANISM UNIT	RYM1235
	6	EJECT ARM L	AMR7024
	7	EJECT ARM R	AMR7025
	8	DAMPER ASSY	AXA7021
	9	SCREW	BSZ20P120FMC
	10	EJECT SPRING (L)	ABH7028
NSP	11	EJECT SPRING (R)	ABH7029
	12	DOOR SPRING L	RBH1422
	13	DOOR SPRING R	RBH1423
	14	SPRING	RBK1004
	15	CUSHION A	REB1283
NSP	16	UNDER BASE	RNB1107
NSP	17	SHIELD PLATE	RNE1824
NSP	18	COLLAR	RNK2135
	19	INSULATOR ASSY	RXA1673
	20	PC SUPORT	VEC1549
	21	TC CONTROL BUTTON	REA1163
NSP	22	EJECT KNOB L	RAC1952
	23	EJECT KNOB R	RAC1953
	24	DOOR LENS L	RAH2586
	25	DOOR LENS R	RAH2587
	26	INDICATOR	REE1019
	27	BONNET	REA1180
	28	REAR BASE AEM	RNA1872
	29	LED LENS	RNK2128
	30	TC FRONT PANEL	REA1190
	31	DOOR PANEL L	REA1158
	32	DOOR PANEL R	REA1159
	33	AZIMUTH COVER L	REA1160
	34	AZIMUTH COVER R	REA1161
	35	DOOR POCKET L	RNK2124
	NSP	36	DOOR POCKET R
37		TC BUTTON A	REA1164
38		TC BUTTON B	REA1165
39		SCREW	BBZ30P060FMC
40		SCREW	BBZ30P080FZK
41		SCREW	CBZ30P080FZK
42		SCREW	IPZ30P080FCU
43	SCREW	PPZ30P080FMC	

■ Mechanism Unit Section

● Mechanism unit I and II (1/2)

Mark	No.	Description	Parts No.
NSP	1	ASSY MOTOR	RXM1080
	2	JUMPER WIRE	RDD1012
	3	BRACKET MOTOR	RNE1830
	4	SPACER	RNK1822
	5	SCREW	RBA1100
	6	SCREW	PCZ20P040FMC

Mark	No.	Description	Parts No.
	36	
	37	P. C. BOARD	RNP1610
	38	SWITCH MODE	RSN1020
	39	SWITCH (LEAF)	RSN1019
	40	HALL IC	DN6851A
	41	ASSY BRACKET (*1)	RXA1665
	41	BRACKET FW (*2)	RNE1438
	42	PULLEY (*1 only)	RNK2132
	43	
	44	
	45	BELT MAIN (*1)	REB1273
	45	BELT MAIN (*2)	REB1272

● Mechanism unit I and II (2/2)

Mark	No.	Description	Parts No.
	1	ASSY HOLDER HEAD (*1)	RXA1400
	1	ASSY HOLDER HEAD (*2)	RXA1664
	2	FRAME HEAD	RNK1715
	3	LEVER HEAD	RNK1716
	4	SPRING AZIMUTH	RBK1006
	5	ASSY ARM ASSIST	RXA1401
	6	GEAR ARM HEAD	RNK1717
	7	SPRING CASSETTE	RBK1039
	8	EJECT LOCK	RNK1718
	9	CAP REEL	RNK1719
	10	ASSY PINCH ARM L	RXA1403
	11	CHASSIS HEAD	RNE1437
	12	ASSY PINCH ARM R	RXA1404
	13	ARM PLAY L	RNK1866
	14	GEAR PLAY	RNK1867
	15	ARM PLAY R	RNK1868
	16	CHASSIS OS	RXA1411
	17	ASSY SUB REEL L	RXA1407
	18	SOLENOID	RXP1020
	19	WIRE	RDC1006
	20	ARM RVS	RNK1721
	21	GEAR FF	RNK1723
	22	ASSY ARM FR	RXA1412
	23	ASSY PULLEY FR	RXA1413
	24	BELT FR	REB1158
	25	METAL	RNG1048
	26	ASSY FLYWHEEL L (*1)	RXA1666
	26	ASSY FLYWHEEL L2 (*2)	RXA1668
	27	METAL	RNG1005
	28	ARM BRAKE	RNK1724
	29	ASSY SUB REEL R	RXA1408
	30	ARM TRIGGER	RNK1722
	31	GEAR CAM	RNK1725
	32	METAL	RNG1049
	33	ASSY FLYWHEEL R (*1)	RXA1667
	33	ASSY FLYWHEEL R2 (*2)	RXA1669
	34	METAL	RNG1004
	35	

	46	P. C. BOARD	RNP1348
	47	HOUSING (*1)	RKP1396
	47	HOUSING (*2)	RKP1397
	48	CONNECTOR (*1)	RKP1713
	48	CONNECTOR (*2)	RKP1714
	49	
	50	
	51	SPRING	RBH1282
	52	SPRING	RBH1283
	53	SPRING	RBH1284
	54	SPRING	RBH1286
	55	SPRING	RBH1288
	56	SPRING	RBH1291
	57	SPRING	RBH1285
	58	SPRING	RBH1287
	59	SPRING	RBH1289
	60	SPRING	RBH1290
	61	SPRING	RBH1292
	62	FWP SP (SPRING)	RBH1061
	63	SPRING	RBH1325
	64	SCREW (FOR AZIMUTH)	RBA1023
	65	SCREW	RBA1027
	66	SCREW	RBA1030
	67	SCREW	PCZ20P040FMC
	68	SCREW	RBA1093
	69	SCREW	RBA1094
	70	WASHER	RBF1046
	71	WASHER	WA26D04D013
	72	WASHER (*1 only)	WT13D03D025

Note)
 *1: Mechanism Unit I
 *2: Mechanism Unit II

● Mechanism unit I and II (1/2)

● Mechanism unit I and II (2/2)

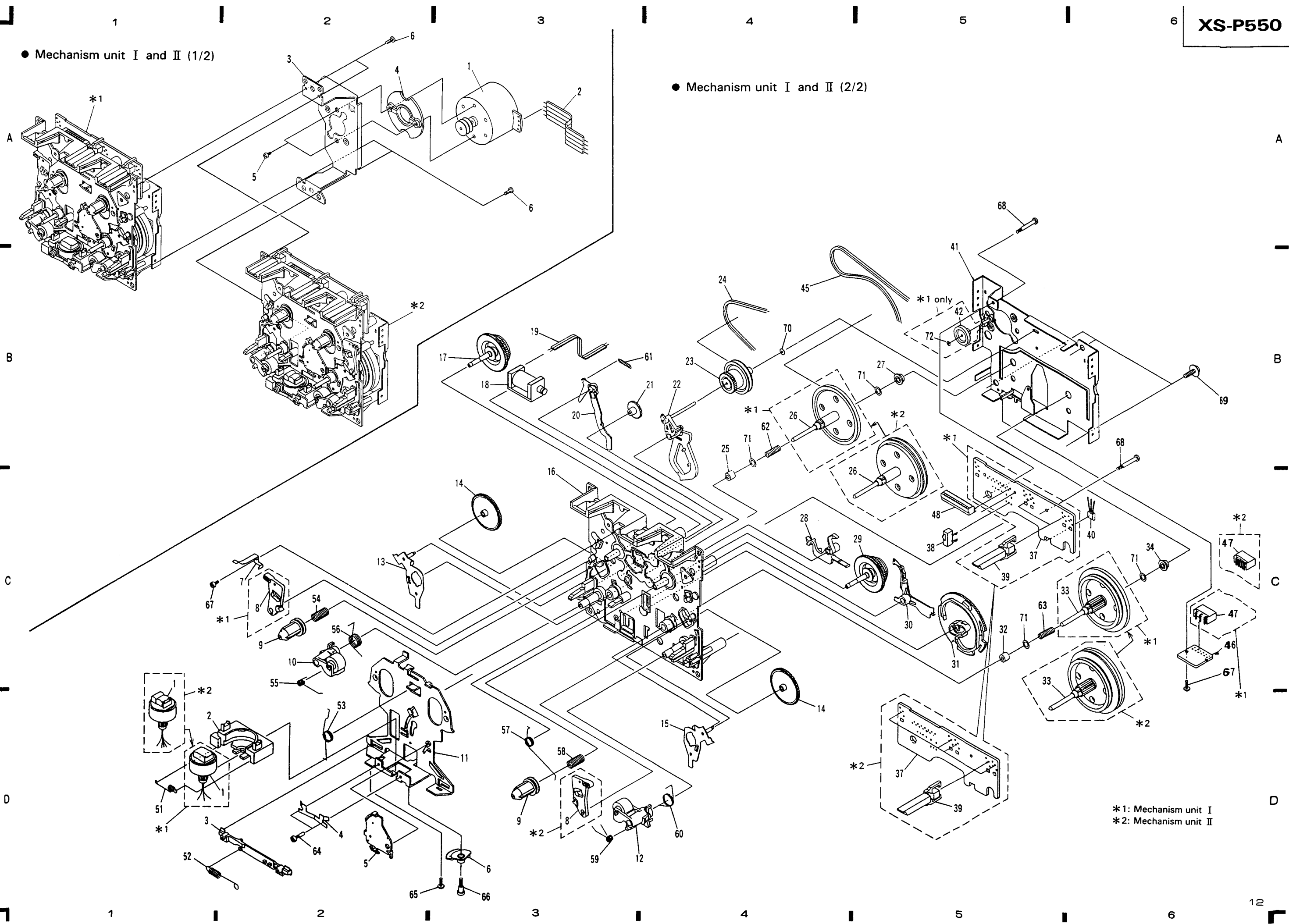

*1: Mechanism unit I
*2: Mechanism unit II

3. COMPACT DISC PLAYER (PD-P550)

Exterior

Mark	No.	Description	Parts No.
	1	CD. MAIN ASSY	RWZ3442
NSP	2	CD. FUNC ASSY	RWZ3443
A	3	CUSHION A	REB1283
NSP	4	UNDER BASE	RNB1107
NSP	5	SUB CHASSIS K	RNE1845
	6	
	7	INSULATOR ASSY	RXA1673
NSP	8	PC SUPORT	VEC1549
NSP	9	SINGLE MECHA ASSY	RXA1672
	10	CD BUTTON A	REA1184
	11	CD CONTROL A	REA1156
	12	CD CONTROL B	REA1157
	13	CD FRONT PANEL	RAH2615
	14	NAME PLATE	RAH2495
	15	BONNET	REA1182
NSP	16	REAR BASE AEM	RNA1875
	17	SCREW	BBZ30P080FZK
B	18	SCREW	BBZ30P160FMC
	19	SCREW	BBZ40P060FZK
	20	SCREW	PDZ30P050FMC
	21	SCREW	PPZ30P080FMC
	22	BINDER (SKB-90BK)	Z09-056
	23	CAUTION LABEL (MEXK/EA, MEXK/EB and MEZIXK/DI types)	PRW1233
NSP	24	LABEL (F)	VRW-328
	25	CAUTION LABEL (G)	VRW-329
	26	CAUTION LABEL (MEXK/EA, MEXK/EB and MEZIXK/DI types)	VRW1094
	27	CAUTION LABEL (NBXK type only)	PRW1018

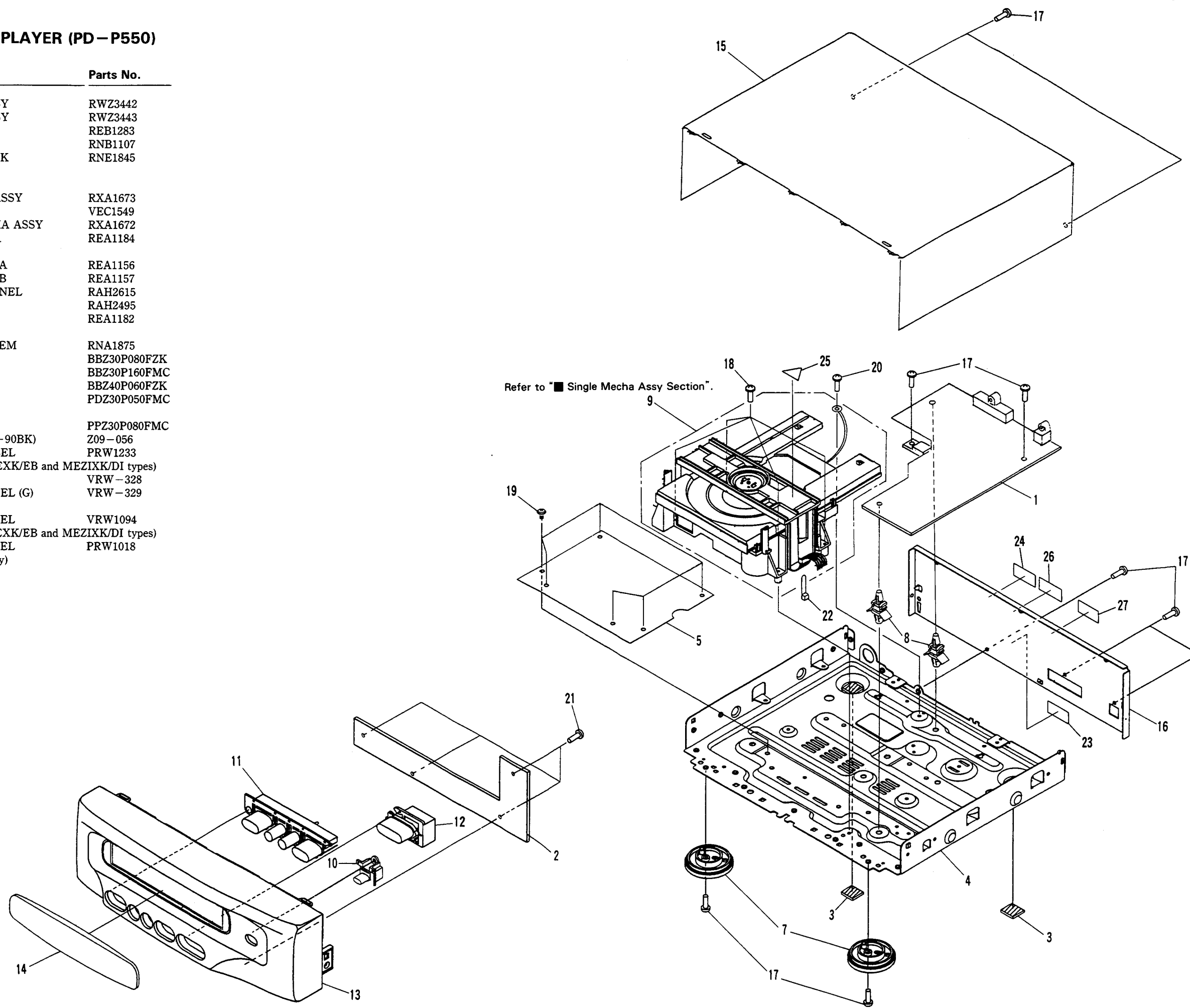

A

B

C

D

Single Mecha Assy Section

Mark	No.	Description	Parts No.
	1	LEVER SWITCH (CLAMP, S601)	DSK1003
	2	FLOAT SCREW	PBA1048
	3	RUBBER BELT	PEB1193
	4	MOTOR PULLEY	PNW1634
A	5	TRAY	PNW2455
	6	FROAT BASE	PNW2032
	7	DRIVE GEAR 2	PNW2369
	8	GEAR PULLEY	PNW2034
	9	CLAMPER BASE	PNW2375
	10	CLAMP CAM	PNW2364
	11	DC MOTOR/0.75W (LOADING)	PXM1010
	12	FLOAT RUBBER B	REB1287
	13	FLOAT RUBBER G	REB1288
	14	SCREW	BPZ26P100FMC
	15	SCREW	Z39-019
	16	SCREW	PMZ26P040FMC
	17	PINION GEAR	PNW2055
NSP	18	DC MOTOR (CARRIAGE)	PXM1027
	19	DC MOTOR ASSY (SPINDLE)	PEA1235
	20	CARRIAGE BASE	PNW2445
B	21	DISC TABLE	PNW1608
	22	SCREW	JFZ20P030FNI
	23	SCREW	JFZ17P025FZK
	24	GEAR 3	PNW2054
	25	GEAR 2	PNW2053
	26	WASHER	WT12D032D025
	27	PICKUP ASSY	PEA1291
	28	GUIDE BAR	PLA1094
	29	GEAR 1	PNW2052
NSP	30	GEAR STOPPER	PNB1303
	31	SCREW	BPZ20P060FMC
	32	PWB HOLDER	PNW2057
	33	SCREW	BPZ26P100FMC
	34	EARTH LEAD UNIT	PDF1104
	35	SCREW	BBZ26P060FMC
C	36	MECHANISM BOARD ASSY	PWX1192
	37	CLAMP MAGNET	PMF1014
	38	YOKE	PNB1216
NSP	39	H RUBBER	PEB1249
	40	CLAMPER S	PNW1609
	41	LOADING BASE	PNW2376
	42	DC MOTOR ASSY (CARRIAGE)	PEA1246
NSP	43	SERVO MECHANISM ASSY SL	AXA7017
	44	
	45	CONNECTOR ASSY (4P)	RDE1043
	46	CONNECTOR ASSY (5P)	PDE1239

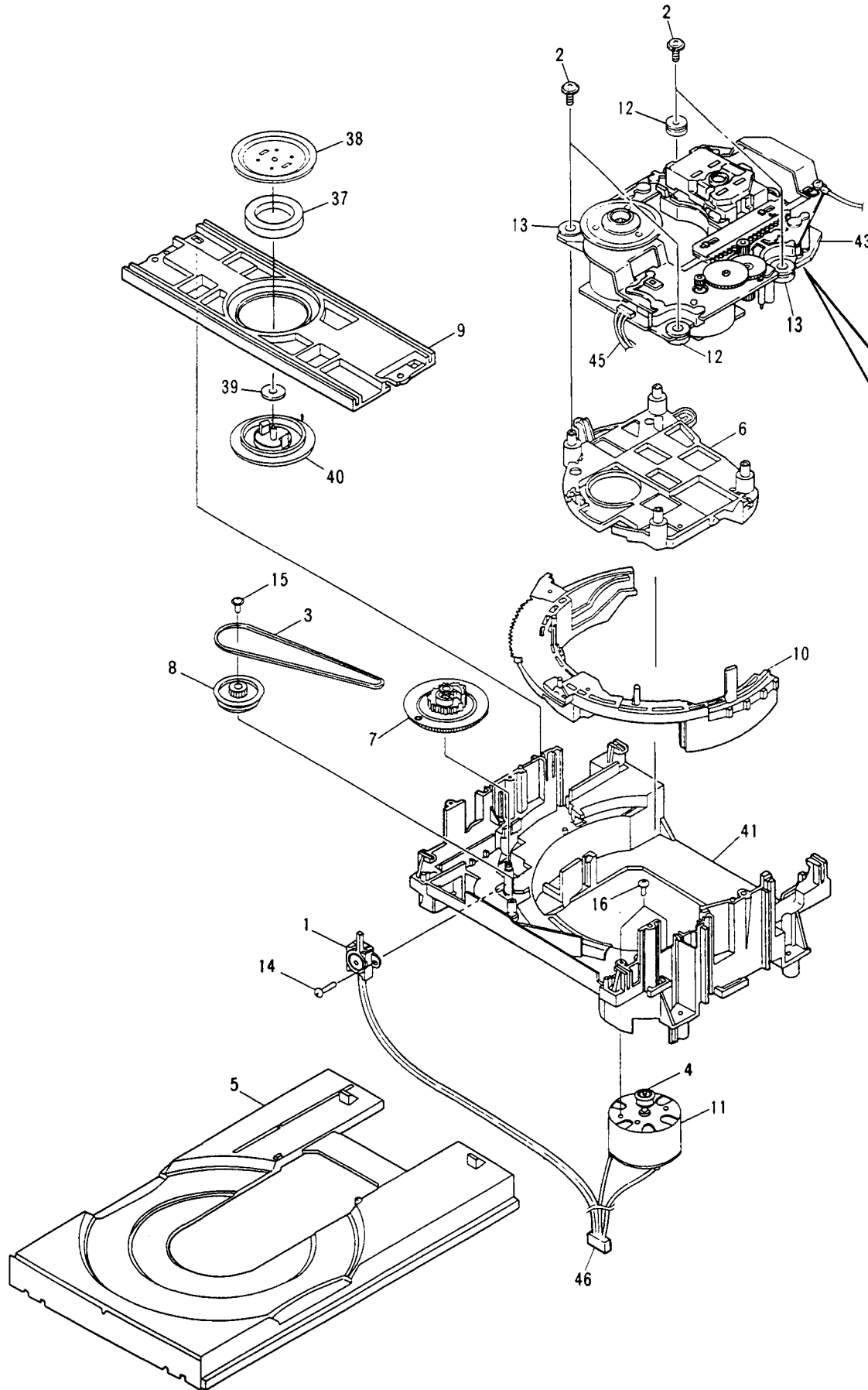

● How to install the disc table

- Use nipper or other tool to cut the three sections marked (A) figure 1. Then remove the spacer.
- While supporting the spindle motor shaft with the stopper, put spacer on top of the motor base (angled so it doesn't touch section (B)), and stick the disc table on top (takes about 9kg pressure). Take off the spacer.

The diagram illustrates the two-step process. Step 1 shows a PWB holder and a spacer being used to cut sections A. Step 2 shows the disc table being placed on the spindle motor shaft, supported by a spacer. Dimensions are given: Disc table thickness is 3.1 mm ± 0.05 mm, and the spacer height is 6.9 mm. The pressure applied should be about 9kg. Labels include PWB Holder, Spacer, Disc table, Spindle motor, and Carriage base.

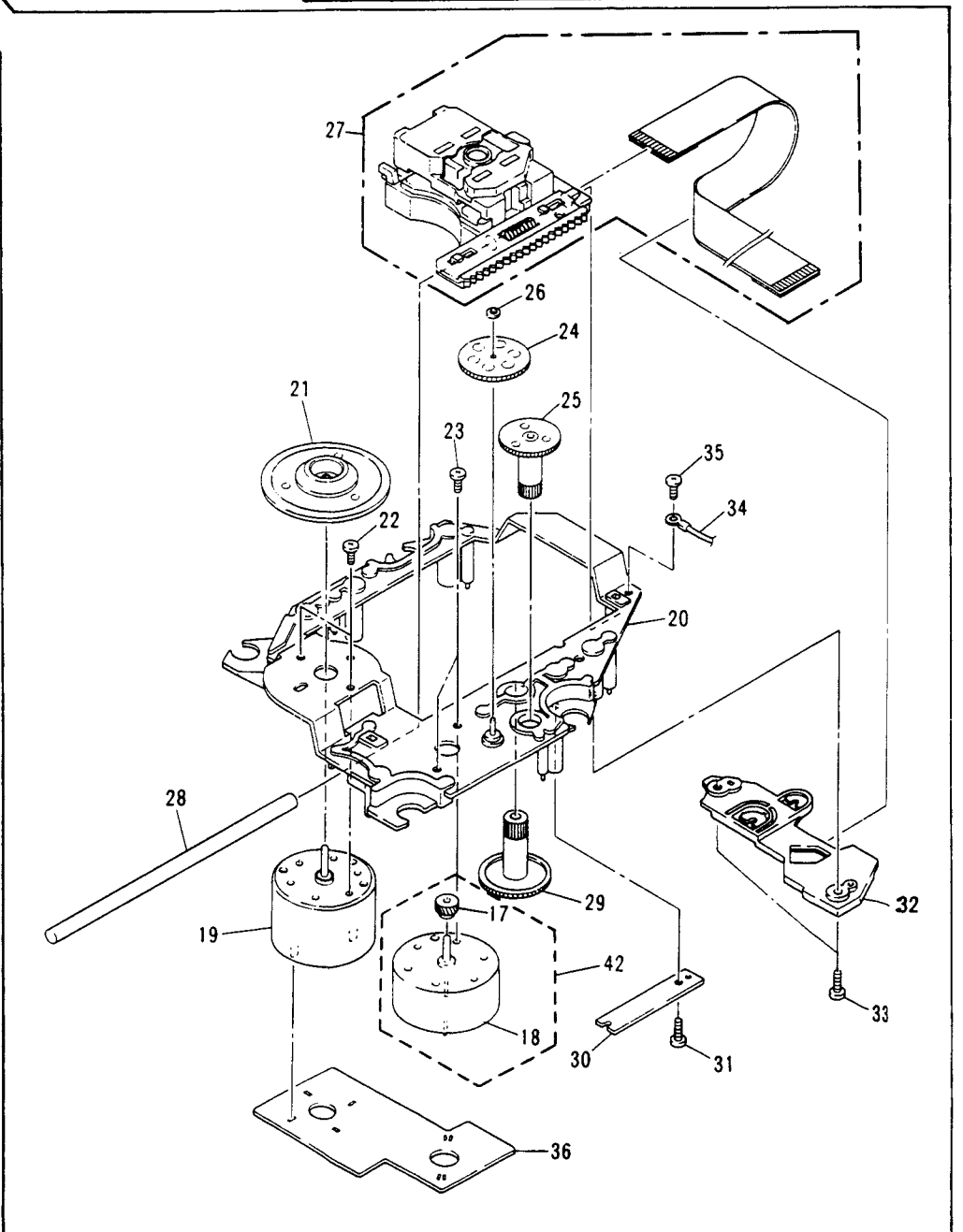

4. STEREO AMPLIFIER (A-P550)

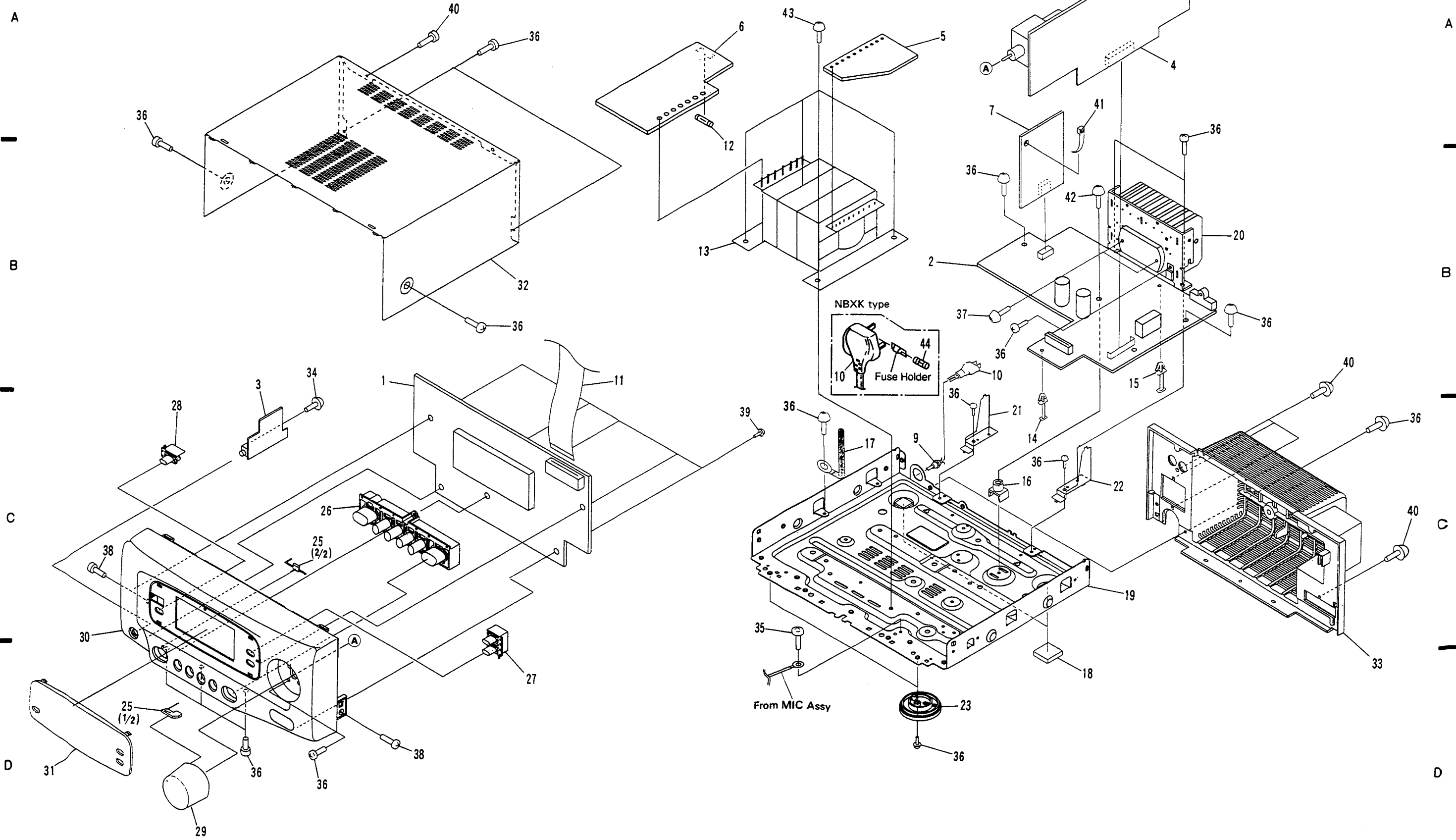

Mark	No.	Description	Parts No.	Mark	No.	Description	Parts No.
	1	DISPLAY ASSY	RWZ3411		36	SCREW	BBZ30P080FZK
	2	MAIN ASSY (MEXK/EA, MEXK/EB and NBXK types)	RWZ3412		37	SCREW	BBZ30P160FMC
	2	MAIN ASSY (MEZIXK/DI type)	RWZ3418		38	SCREW	CBZ30P080FZK
NSP	3	H.P ASSY (MEXK/EA, MEXK/EB and NBXK types)	RWZ3413		39	SCREW	PPZ30P080FMC
NSP	3	H.P ASSY (MEZIXK/DI type)	RWZ3419		40	SCREW	PPZ30P100FZK
	4	SFC ASSY (MEXK/EA, MEXK/EB and NBXK types)	RWZ3414		41	BINDER (SKB-90BK)	Z09-056
	4	SFC ASSY (MEZIXK/DI type)	RWZ3420		42	SCREW	ABA1024
NSP	5	CONNECT ASSY (MEXK/EA, MEXK/EB and NBXK types)	RWZ3415		43	SCREW	ABA1184
NSP	5	CONNECT ASSY (MEZIXK/DI type)	RWZ3421	△	44	FUSE (T5A)	PEK1003
	6	AC. CONNECT ASSY (MEXK/EA, MEXK/EB and NBXK types)	RWZ3416				
	6	AC. CONNECT ASSY (MEZIXK/DI type)	RWZ3422				
NSP	7	SP. OUT ASSY (MEXK/EA, MEXK/EB and NBXK types)	RWZ3417				
NSP	7	SP. OUT ASSY (MEZIXK/DI type)	RWZ3423				
	8					
△	9	STRAIN RELEIF	CM-22B				
△	10	POWER CORD WITH PLUG (MEXK/EA, MEXK/EB and MEZIXK/DI types)	PDG1003				
△	10	POWER CORD WITH PLUG (NBXK type)	PDG1055				
	11	22P F • F • C/30V	RDD1323				
△	12	FUSE (T1A, FU2001)	AEK1054				
△	13	POWER TRANSFORMER	RTT1285				
NSP	14	PCB SPACER (3×8)	AEC1371				
	15	PCB SPACER (3×12)	AEC1372				
NSP	16	PCB MOULD	AMR2115				
NSP	17	CORD HOLDER	DNF1128				
NSP	18	CUSHION A	REB1283				
NSP	19	UNDER BASE	RNB1107				
NSP	20	HEAT SINK	RNE1825				
NSP	21	JOINT L	RNE1826				
NSP	22	JOINT R	RNE1827				
	23	INSULATOR ASSY	RXA1673				
	24					
	25	STA. LENS	AAK7118				
	26	AM CONTROL BUTTON	RAC1956				
	27	AM BUTTON A	REA1166				
	28	AM BUTTON B	REA1167				
	29	VOLUME KNOB	AAB7046				
	30	AM FRONT PANEL	RAH2502				
	31	AM DISPLAY WINDOW	RAH2503				
	32	BONNET	REA1181				
	33	REAR PANEL	RNK2131				
	34	SCREW	ABA1005				
	35	SCREW	BBZ30P060FMC				

3. BLOCK DIAGRAM

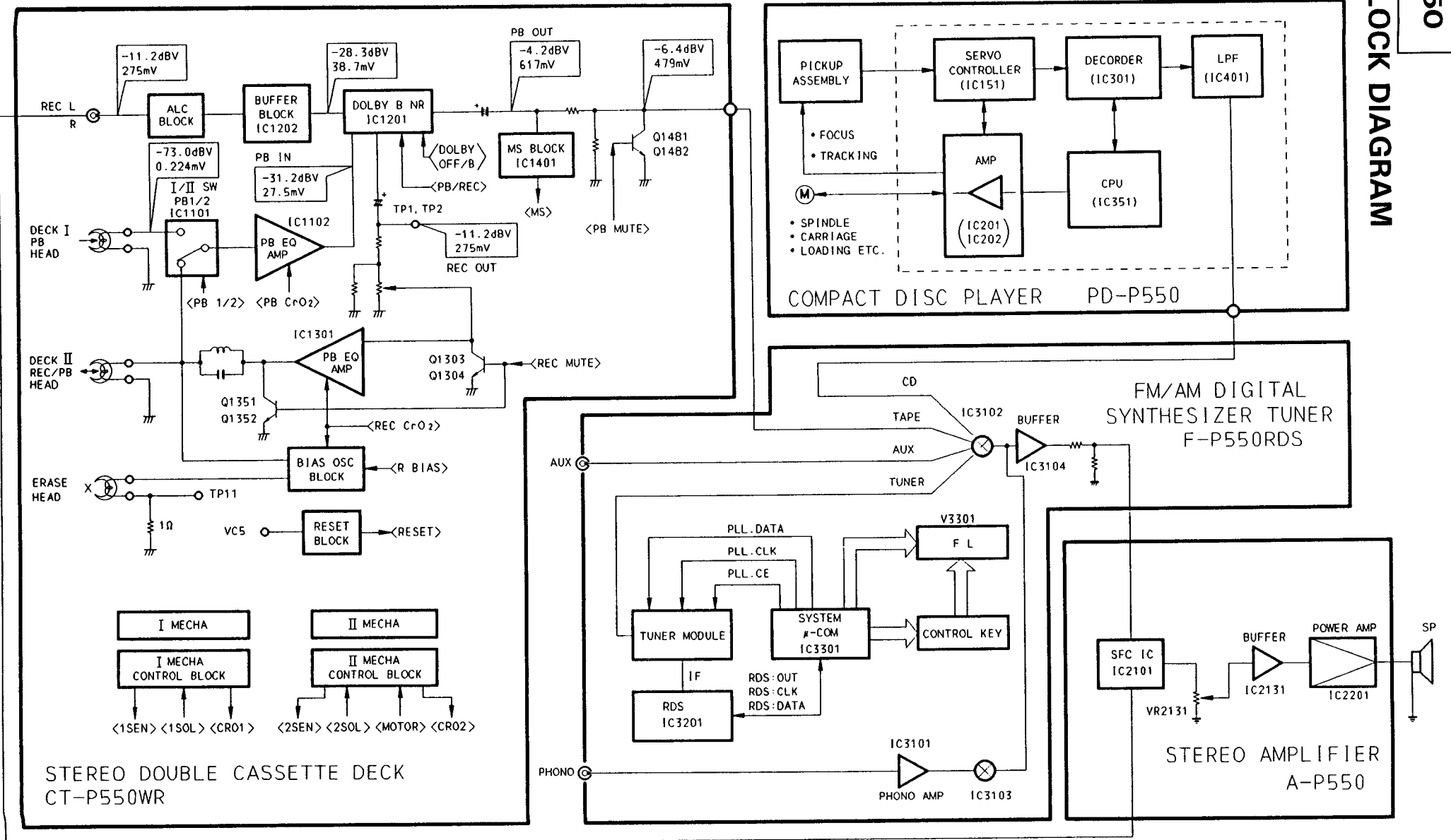

4. SCHEMATIC AND PCB CONNECTION DIAGRAMS

4.1 OVERALL SCHEMATIC DIAGRAM

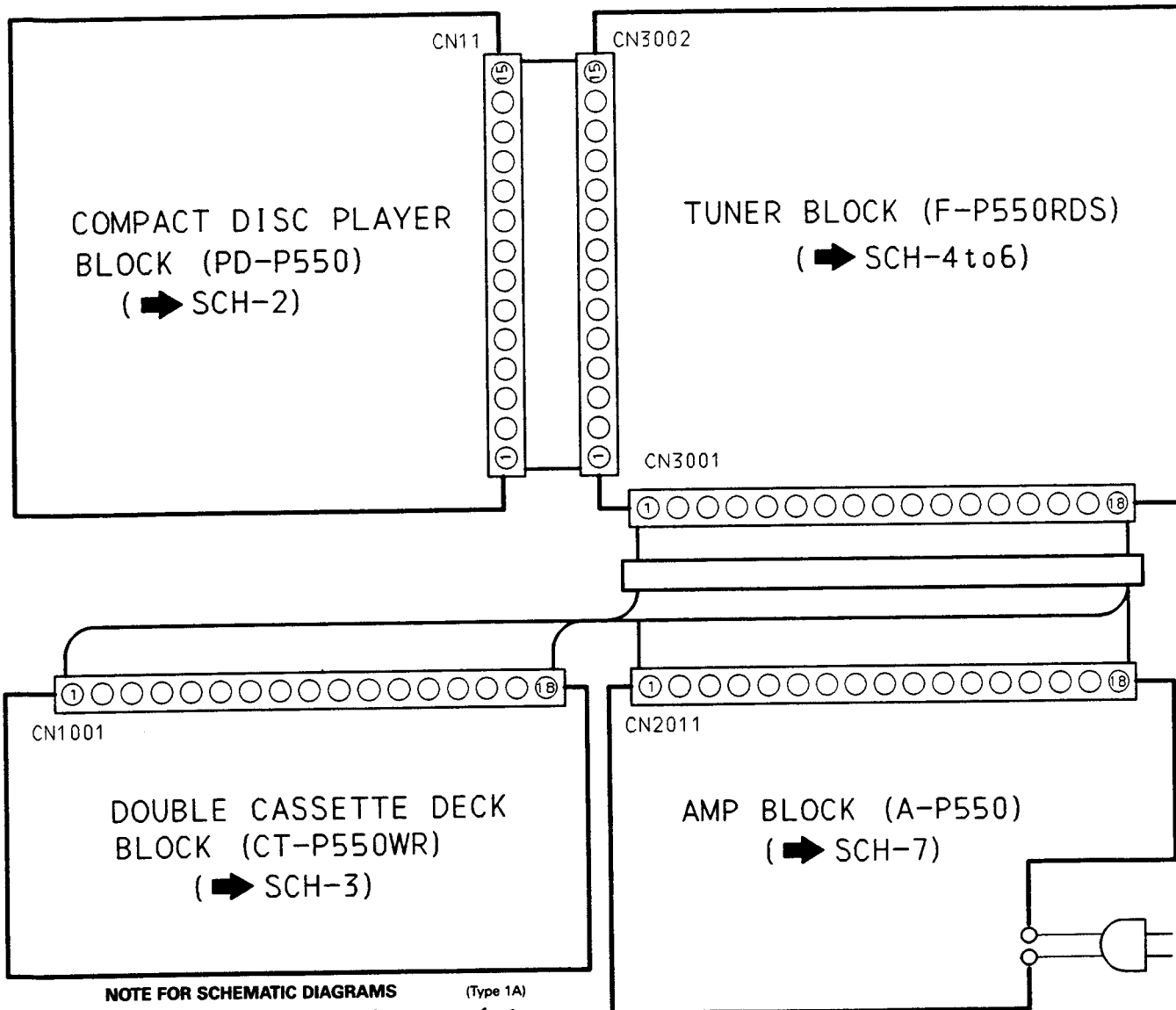

NOTE FOR SCHEMATIC DIAGRAMS (Type 1A)

- When ordering service parts, be sure to refer to "PARTS LIST of EXPLODED VIEWS" or "PCB PARTS LIST".
- Since these are basic circuits, some parts of them or the values of some components may be changed for improvement.
- RESISTORS:**
Unit: k: kΩ, M: MΩ, or Ω unless otherwise noted.
Rated power: 1/4W, 1/6W, 1/8W, 1/10W unless otherwise noted.
Tolerance: (F): ±1%, (G): ±2%, (K): ±10%, (M): ±20% or ±5% unless otherwise noted.
- CAPACITORS:**
Unit: p: pF or μF unless otherwise noted.
Ratings: capacitor (μF)/voltage (V) unless otherwise noted.
Rated voltage: 50V except for electrolytic capacitors.
- COILS:**
Unit: m: mH or μH unless otherwise noted.
- VOLTAGE AND CURRENT:**
 - : Signal voltage at rated output.
 - or : DC voltage (V) at no input signal unless otherwise noted. Value in () is DC voltage at rated power.
 - or : DC current at no input signal unless otherwise noted.
- OTHERS:**
 - or : Adjusting point.
 - : Measurement point.
 - The mark found on some component parts indicates the importance of the safety factor of the parts. Therefore, when replacing, be sure to use parts of identical designation.
- SCH-□ ON THE SCHEMATIC DIAGRAM:**
 - SCH-□ indicates the drawing number of the schematic diagram. (SCH stands for schematic diagram.)

9. SWITCHES (Underline indicates switch position):

- F-P550RDS DISPLAY ASSY**
 - S3301 - (TUNING)
 - S3302 + (TUNING)
 - S3303 STATION
 - S3304 FUNCTION
 - S3304 FUNCTION (TUNER → TAPE → CD → PHONO → VIDEO)
 - S3306 AM
 - S3307 DISPLAY
 - S3308 STATION MEMORY
 - S3309 MONO
- PD-P550 CD.FUNC ASSY**
 - S501
 - S502
 - S503
 - S504
 - S505
 - S506 PGM/EDIT
 - S507 RANDOM
- CT-P550WR TC.FUNC ASSY**
 - S1901
 - S1902
 - S1903 REC/PAUSE
 - S1904 SELECTOR (DECK I • II)
 - S1905
 - S1906
 - S1907
 - S1951 ASES/COPY
 - S1952 DOLBY NR ON/OFF
- A-P550 DISPLAY ASSY**
 - S2501 WAKE-UP
 - S2502 REC (TIMER)
 - S2503 SFC MODE
 - S2504 ST WIDE
 - S2505 P. BASS
 - S2506 + (CLOCK)
 - S2507 - (CLOCK)
 - S2508 POWER
 - S2509 SLEEP

4.2 COMPACT DISC PLAYER (PD – P550)



CD. MAIN ASSY, CD. FUNC ASSY AND SINGLE MECHA ASSY

Waveforms

Note: The encircled numbers denote measuring point in the schematic diagram.

*1 50T-JUMP: After switching to the pause mode, press the manual search key.

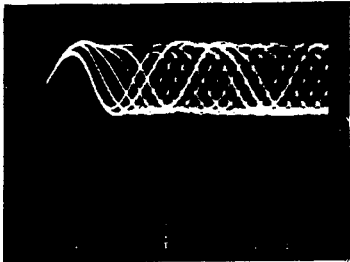
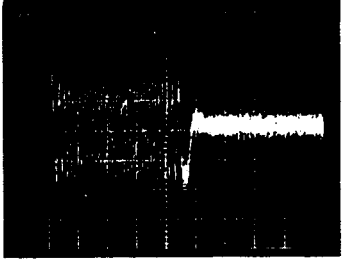
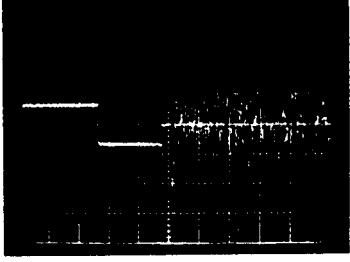
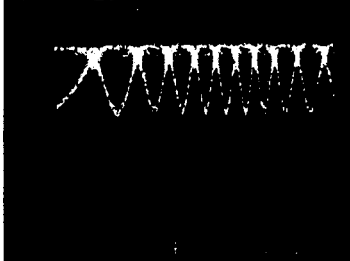
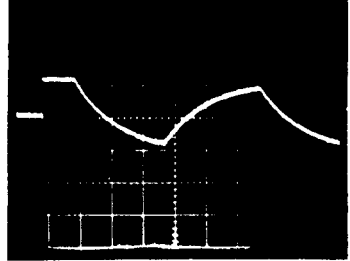
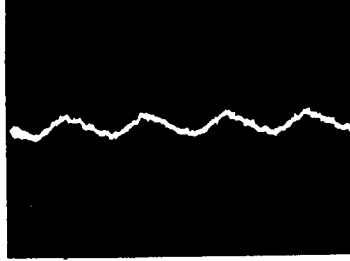
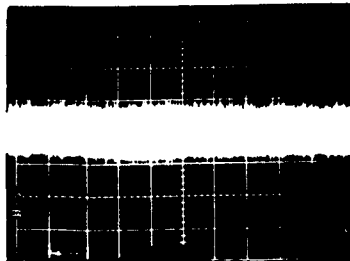
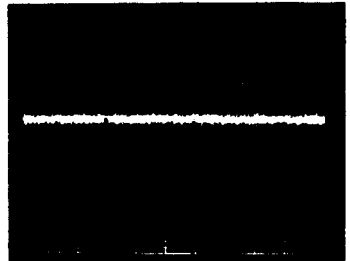
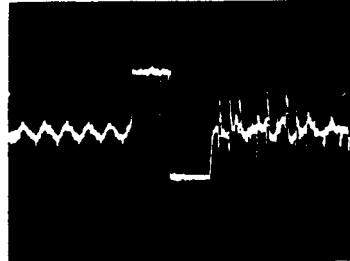
*2 FOCUS-IN: Press the key without loading a disc.

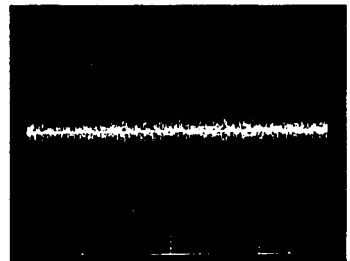
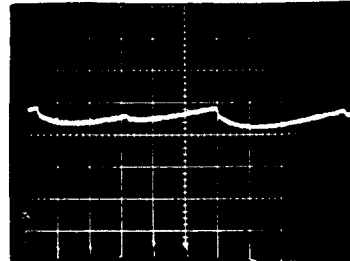
<p>2 TP1-Pin1: PLAY MODE (RF) 500mV/div 500nsec/div</p>  <p style="text-align: right;">- VC</p>	<p>4 TP1-Pin2: 50T-JUMP (*1) MODE (TRER) 1V/div 1msec/div</p>  <p style="text-align: right;">- VC</p>	<p>6 IC201-Pin3: 50T-JUMP (*1) MODE (TRDR) 500mV/div 1msec/div</p>  <p style="text-align: right;">- GND</p>
<p>2 TP1-Pin1: TRACK SEARCH MODE (RF) 500mV/div 200µsec/div</p>  <p style="text-align: right;">- VC</p>	<p>5 IC201-Pin1: FOCUS-IN (*2) MODE (FODR) 1V/div 200msec/div</p>  <p style="text-align: right;">- GND</p>	<p>7 IC202-Pin3: PLAY MODE (SPDR) 2V/div 50msec/div</p>  <p style="text-align: right;">- GND</p>
<p>3 TP1-Pin6: PLAY MODE (FOER) 100mV/div 10msec/div</p>  <p style="text-align: right;">- VC</p>	<p>5 IC201-Pin1: PLAY MODE (FODR) 1V/div 1msec/div</p>  <p style="text-align: right;">- GND</p>	<p>7 IC202-Pin3: TRACK SEARCH MODE (SPDR) 2V/div 200msec/div</p>  <p style="text-align: right;">- GND</p>
<p>4 TP1-Pin2: PLAY MODE (TRER) 1V/div 10msec/div</p>  <p style="text-align: right;">- VC</p>	<p>6 IC201-Pin3: PLAY MODE (TRDR) 500mV/div 1msec/div</p>  <p style="text-align: right;">- GND</p>	<p>8 IC202-Pin9: PLAY MODE (CADR) 0.5V/div 2S/div</p>  <p style="text-align: right;">- GND</p>

This diagram is viewed from the mounted parts side.

CD. FUNC ASSY

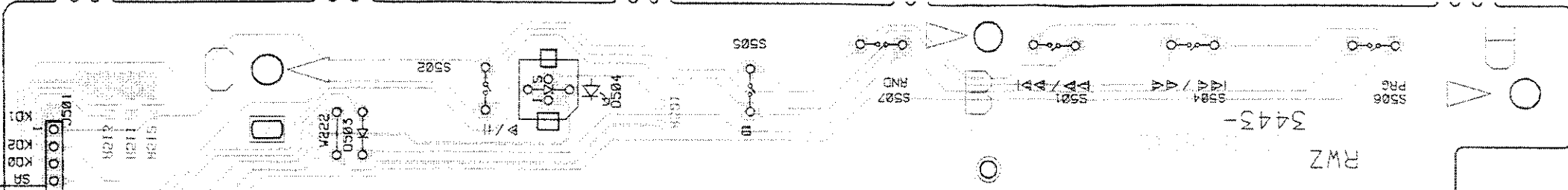

NOTE FOR PCB DIAGRAMS:

- 1. Part numbers in PCB diagrams match those in the schematic diagrams.
- 2. A comparison between the main parts of PCB and schematic diagrams is shown below.

Symbol in PCB Diagrams	Symbol in Schematic Diagrams	Part Name
		Transistor
		Diode
		Capacitor (Polarized)

- 3. The transistor terminal marked with E or \square shows the emitter.
- 4. The diode terminal marked with \ominus or \square shows cathode side.
- 5. The capacitor terminal marked with \ominus or \square shows negative terminal.

NOTE FOR PCB DIAGRAMS:

- 1. Part numbers in PCB diagrams match those in the schematic diagrams.
- 2. A comparison between the main parts of PCB and schematic diagrams is shown below.

Symbol in PCB Diagrams	Symbol in Schematic Diagrams	Part Name
		Transistor with resistor
		Field effect transistor
		Resistor array
		3-terminal regulator

CMKE-P3X

MECHANISM BOARD ASSY

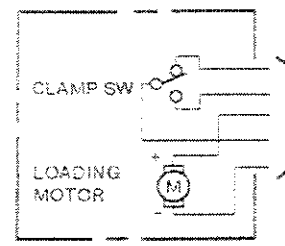
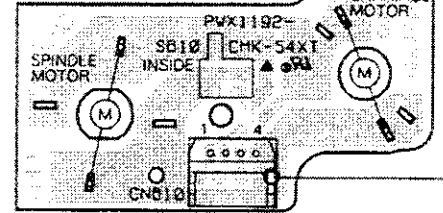

CD. MAIN ASSY

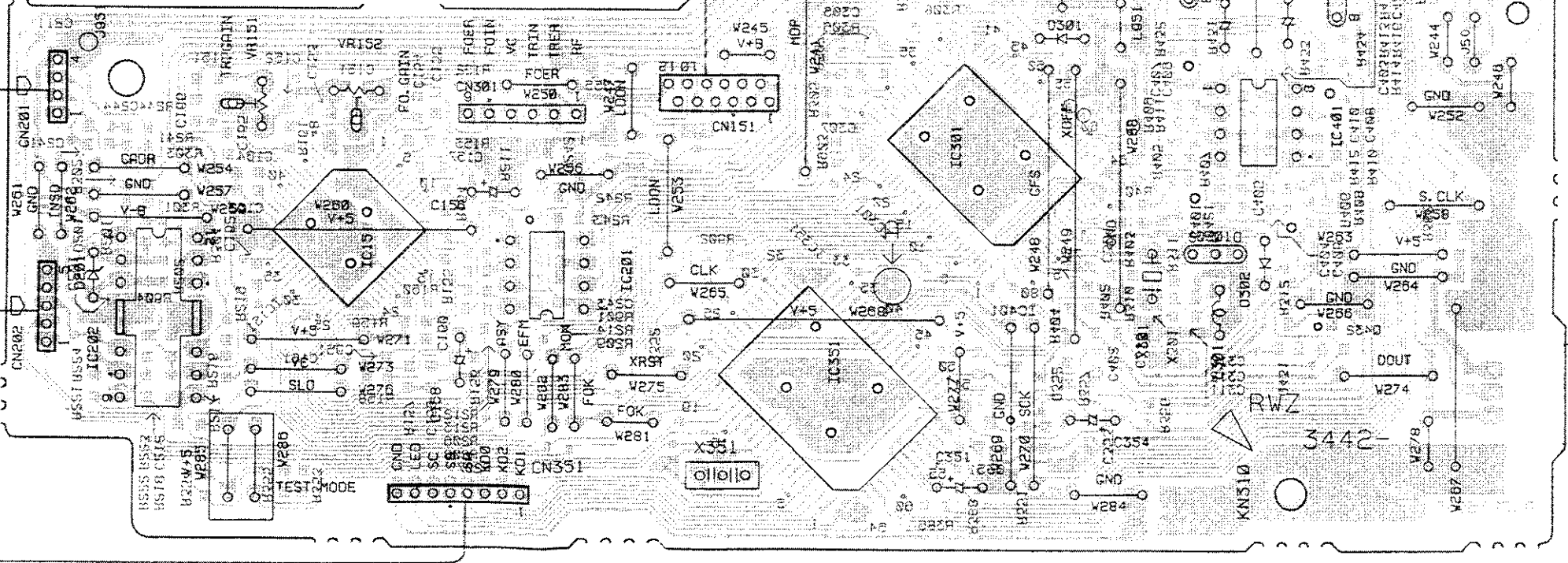

PICK-UP ASSY

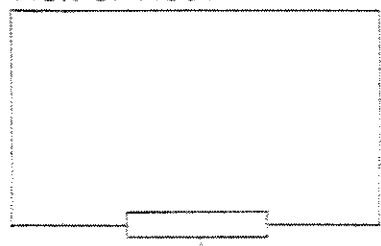

To PRE. AMP assy CN3002

VR151 VR152
 IC202 IC151 IC201 IC351 IC301 IC11 IC22
 Q351 Q352 Q433 IC401 Q434
 Q301 Q431 Q432

A

B

C

D

E

F

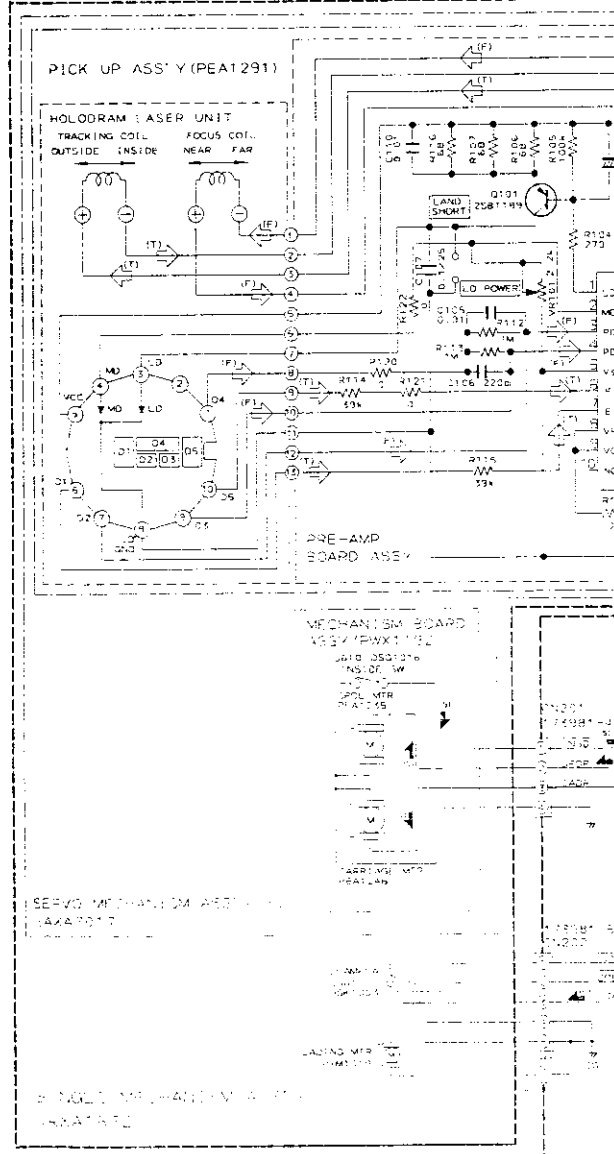
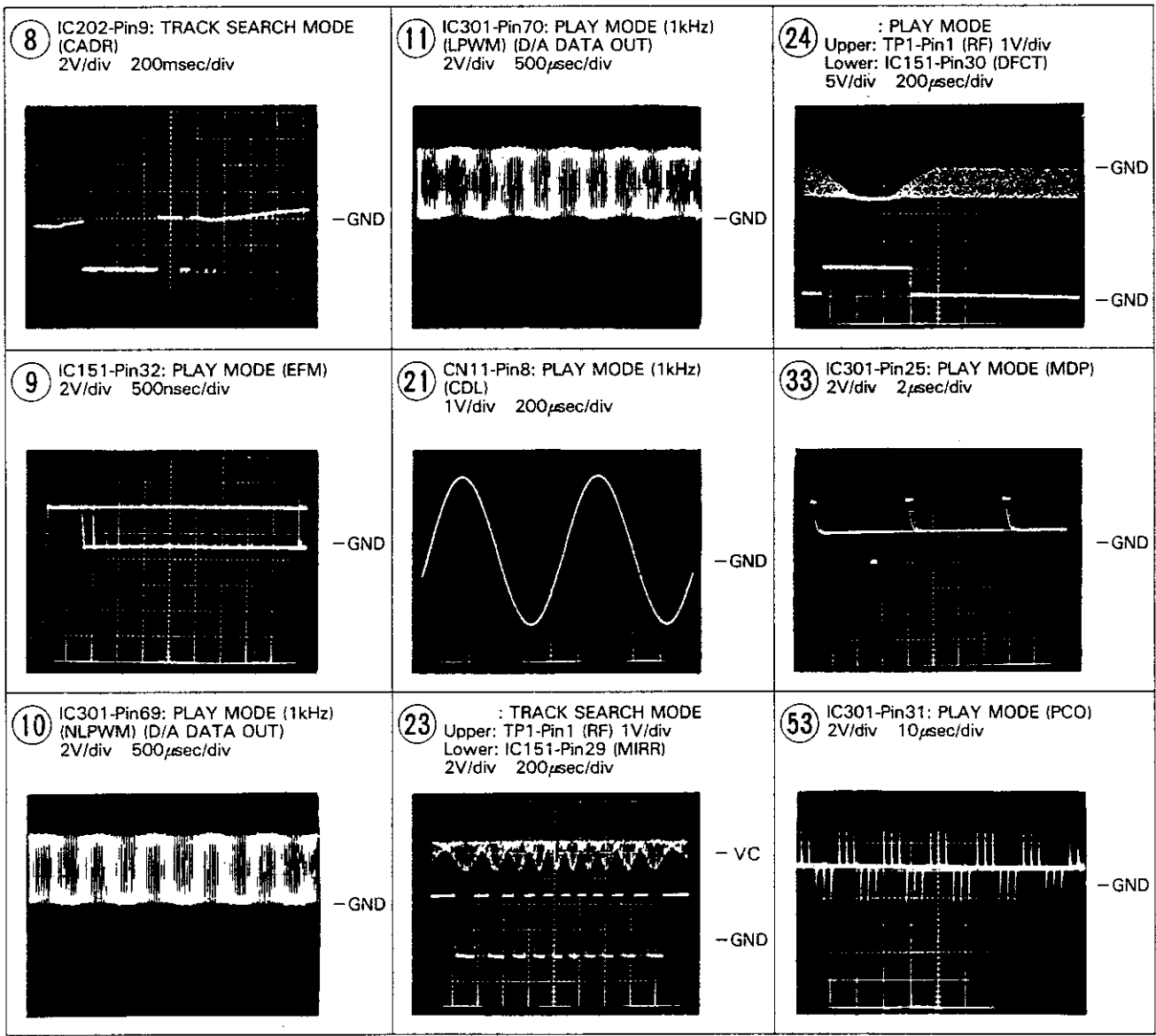

NOTE: ALL SIGNALS ARE REFERENCED TO GROUND UNLESS OTHERWISE SPECIFIED.
 *MA: MECHANISM BOARD ASSY (MNX1115C)
 *SERVO: SERVO MECHANISM ASSY (LAXA7017)

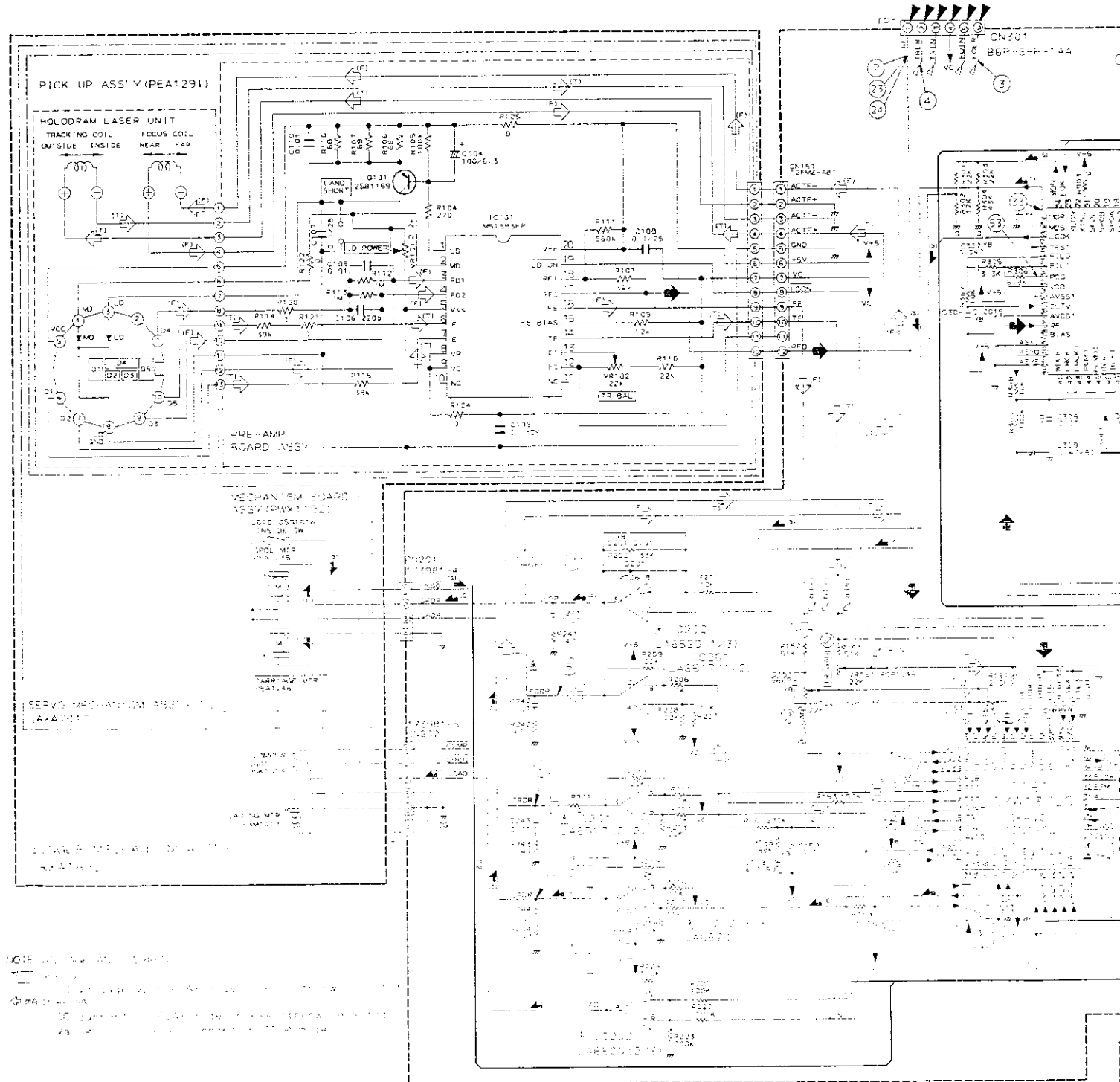
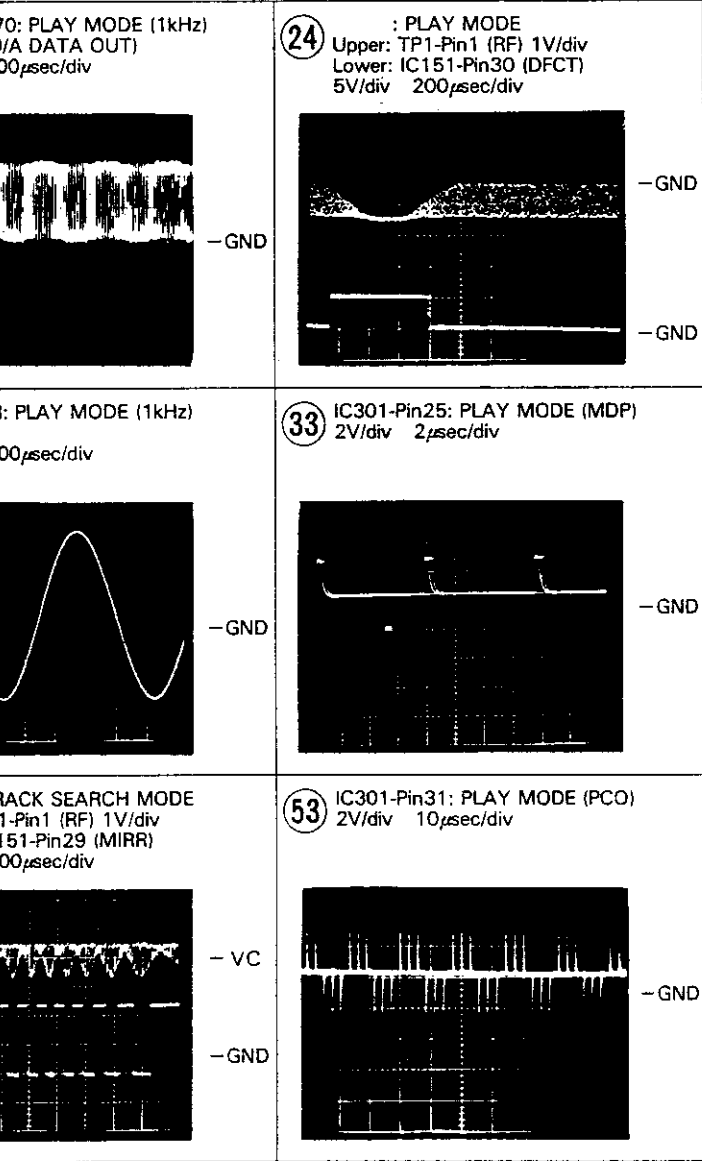

- ▶ 401: LD POWER
- ▶ 402: LD POWER
- ▶ 403: TRACKING SERVO DRIVE LINE
- ▶ 404: CLAMP MOTOR ROUTE
- ▶ 405: TRINITY MOTOR ROUTE
- ▶ 406: TARE MOTOR ROUTE

SCH-2 COMPACT DISC PLAYER (PD-P550)
(CD. MAIN ASSY, CD. FUNC ASSY,
SINGLE MECHA ASSY)

A

B

C

D

E

F

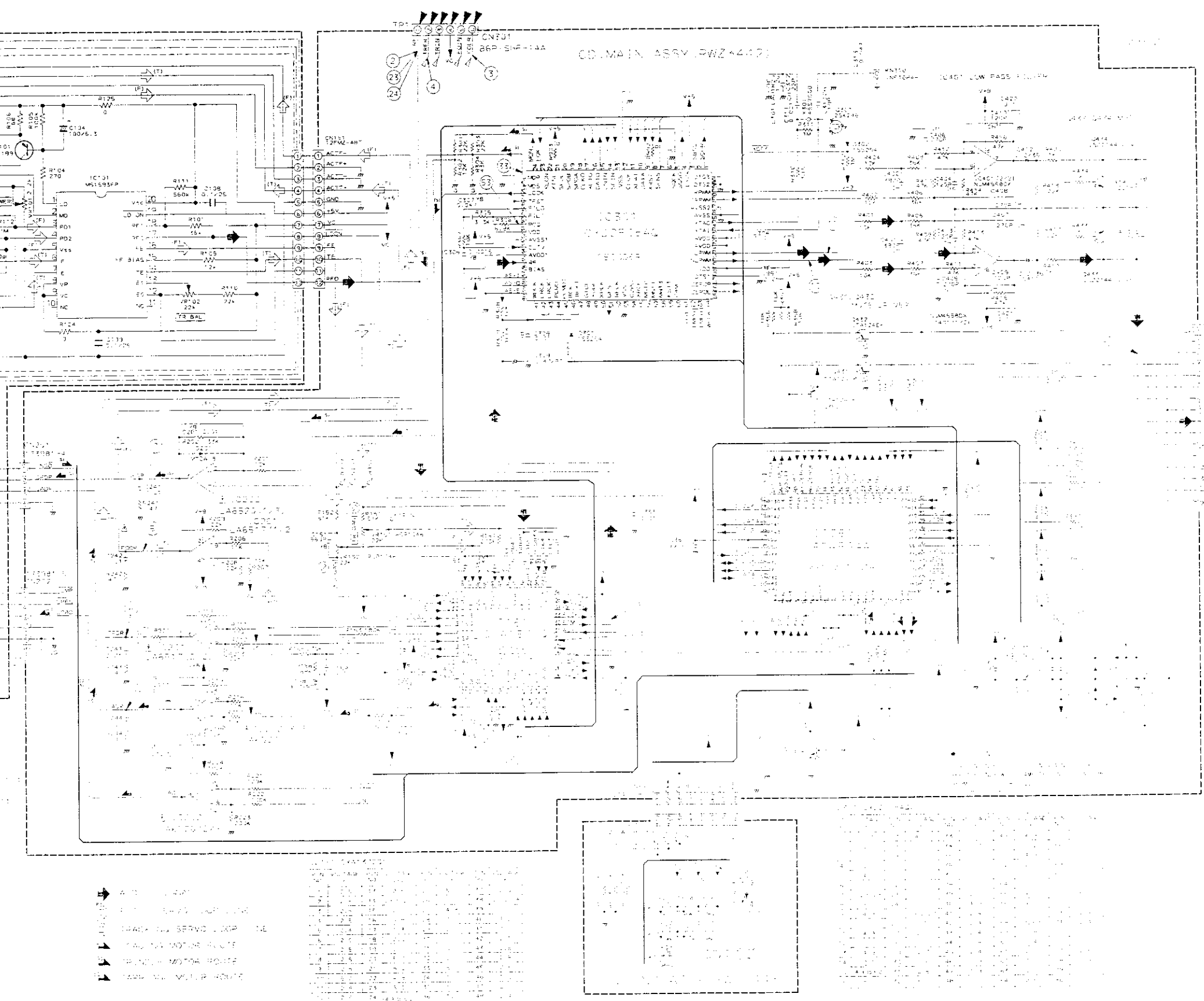

COMPACT DISC PLAYER (PD-P550)
 CD MAIN ASSY, CD FUNC ASSY,
 SINGLE MECHA ASSY

COMPACT DISC PLAYER (PD-P550)
 (CD MAIN ASSY, CD FUNC ASSY,
 SINGLE MECHA ASSY)

SCH-2

4.3 STEREO DOUBLE CASSETTE DECK (CT-P550WR)
TC. MAIN ASSY, TC. FUNC ASSY AND MECHANISM UNIT

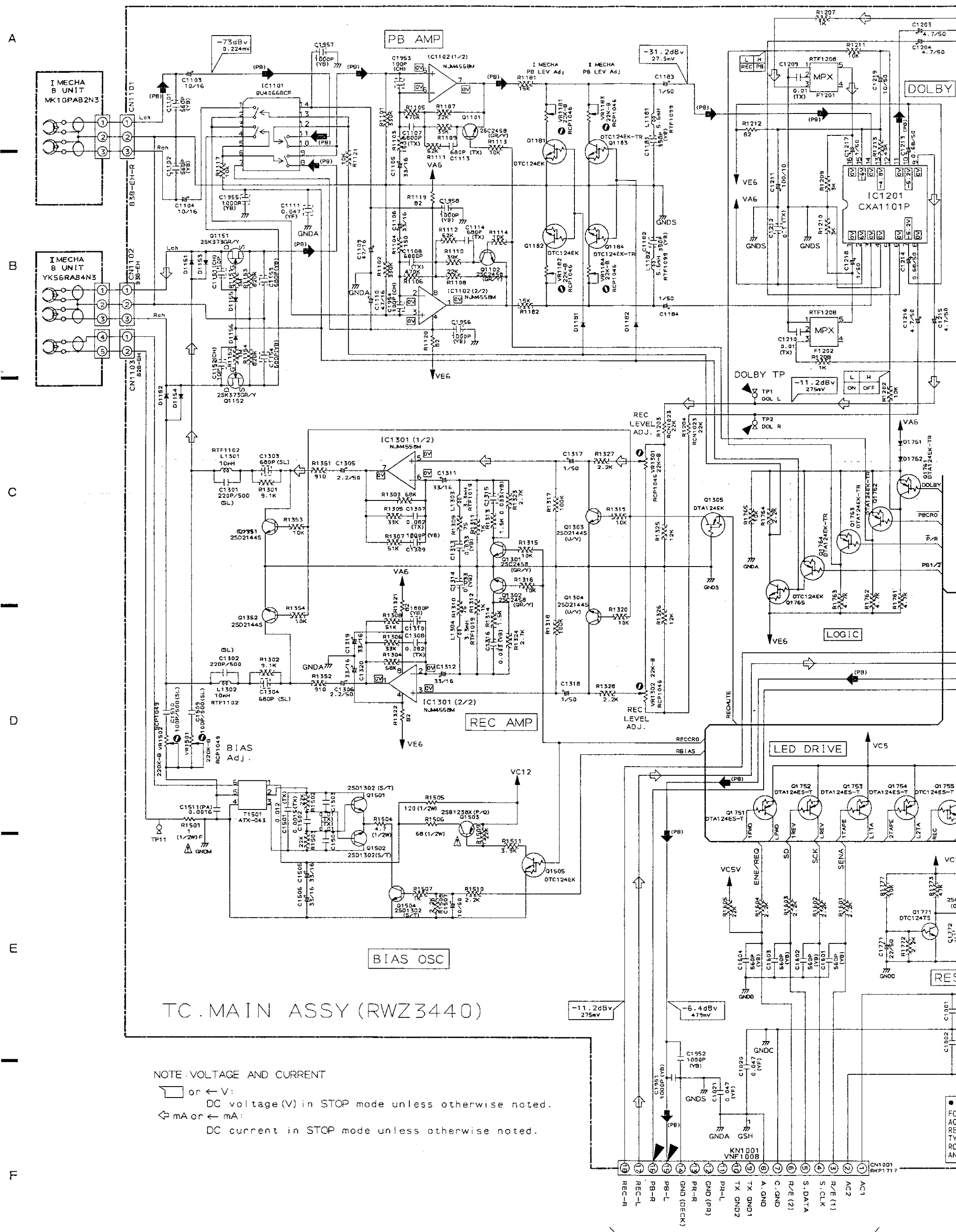

NOTE: VOLTAGE AND CURRENT
or ← V: DC voltage (V) in STOP mode unless otherwise noted.
← mA or ← mA: DC current in STOP mode unless otherwise noted.

SCH-3

STEREO DOUBLE CASSETTE DECK (CT-P550WR)
(TC. MAIN ASSY, TC. FUNC ASSY, MECHANISM UNIT)

To PRE. AMP ASSY CN3001 (SCH-6) and MAIN ASSY CN2011 (SCH-7)

CK (CT-P550WR)
D MECHANISM UNIT

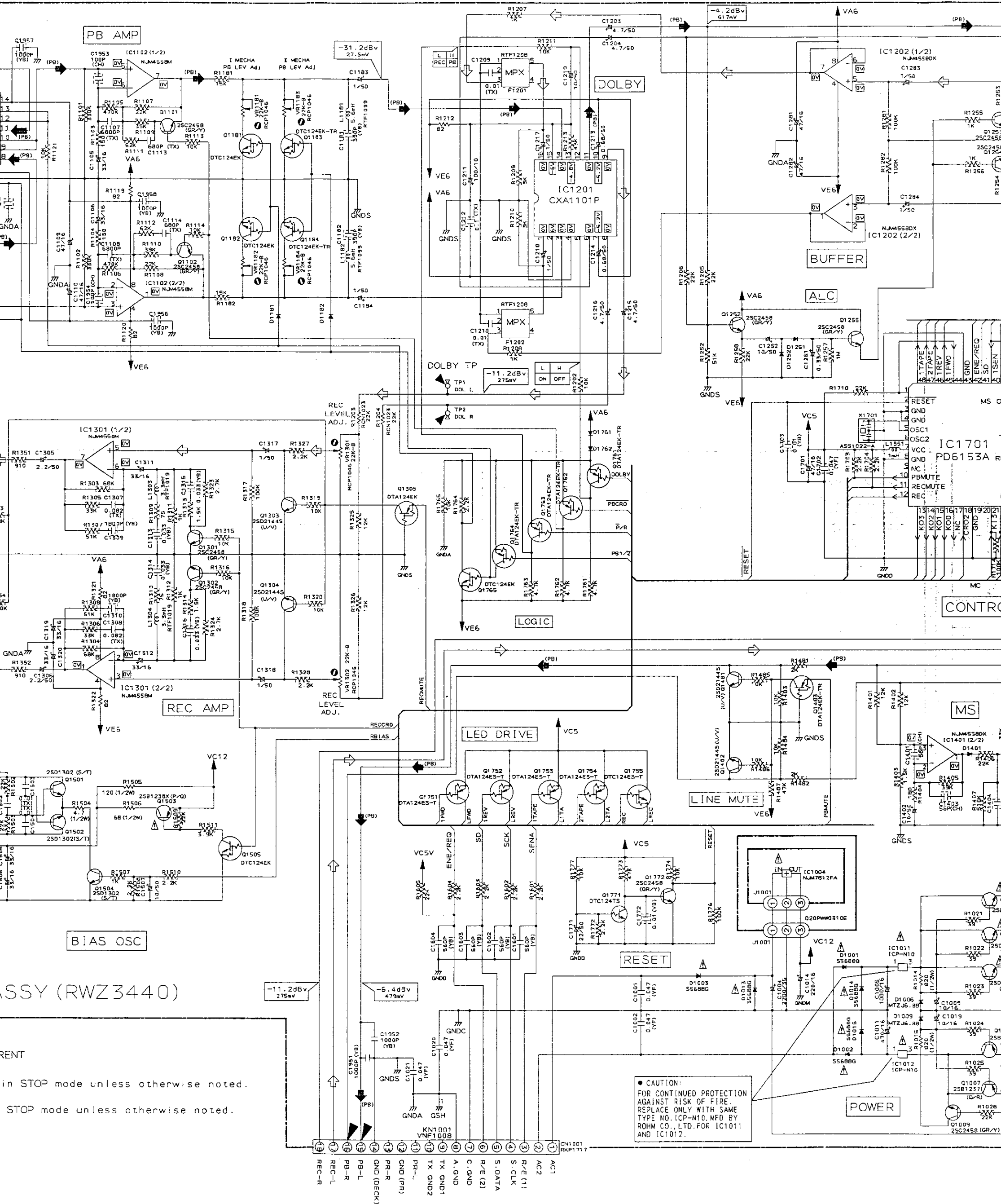

CAUTION:
FOR CONTINUED PROTECTION
AGAINST RISK OF FIRE,
REPLACE ONLY WITH SAME
TYPE NO. ICP-N10, MFD BY
ROHM CO., LTD. FOR IC1011
AND IC1012.

ASSY (RWZ3440)

in STOP mode unless otherwise noted.
STOP mode unless otherwise noted.

To PRE. AMP ASSY CN3001 (→ SCH-6)
and MAIN ASSY CN2011 (→ SCH-7)

ETTE DECK (CT-P550WR)
UNC ASSY,

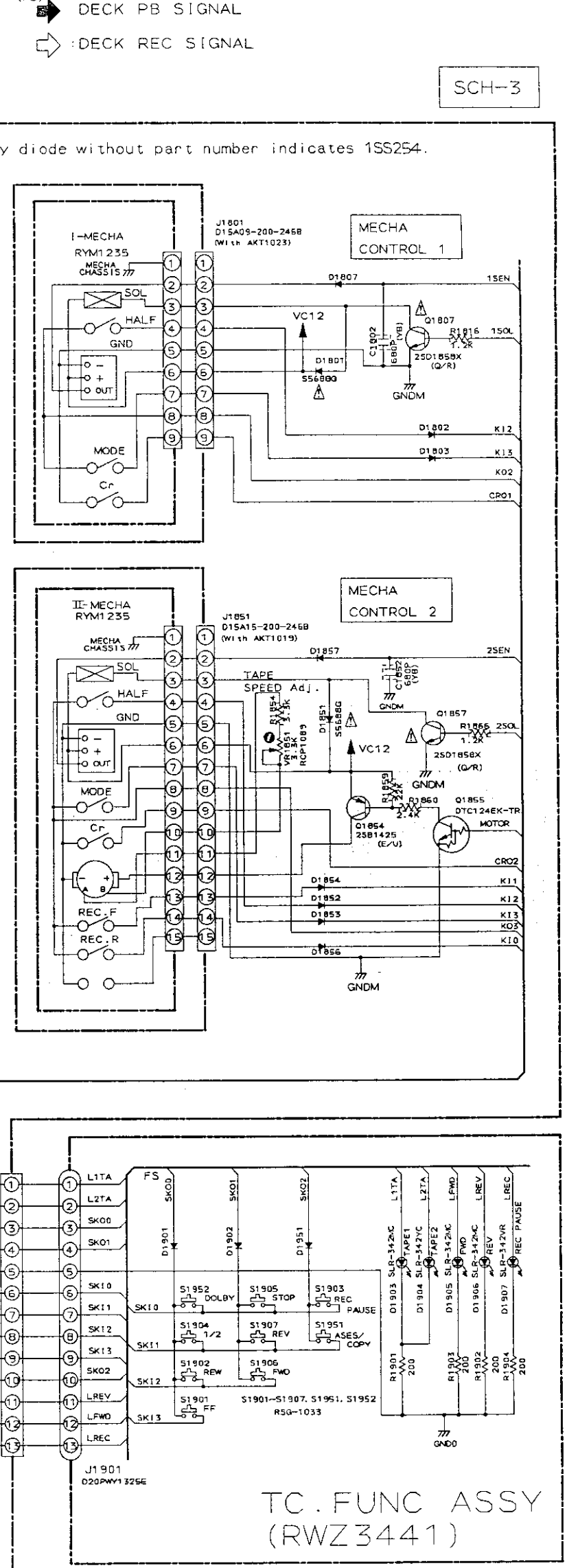
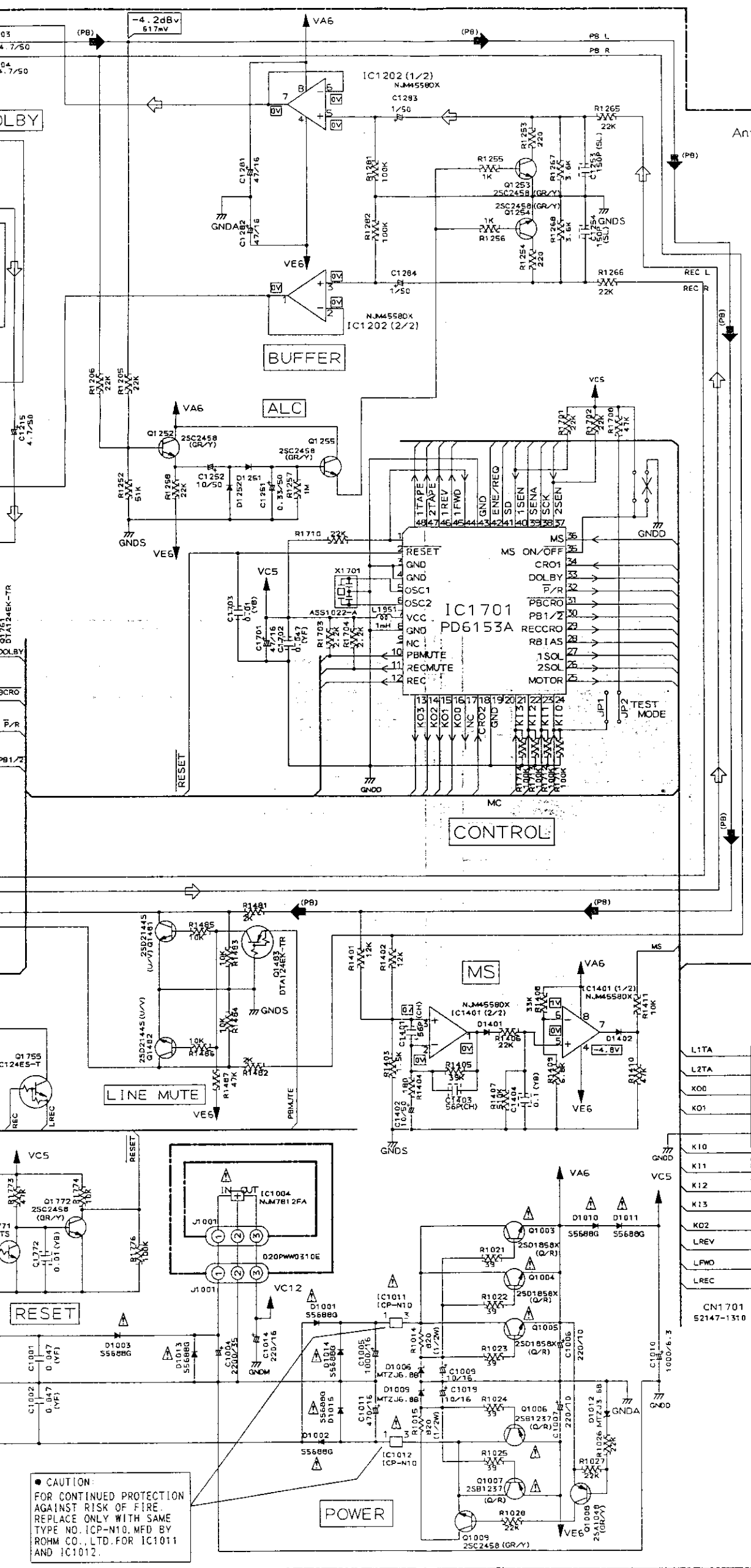

Any diode without part number indicates 1S5254.

SCH-3

TC.FUNC ASSY (RWZ3441)

CAUTION
FOR CONTINUED PROTECTION
AGAINST RISK OF FIRE,
REPLACE ONLY WITH SAME
TYPE NO. ICP-N10, MFD BY
ROHM CO., LTD. FOR IC1011
AND IC1012.

STEREO DOUBLE CASSETTE DECK (CT-P550WR)
(TC. MAIN ASSY, TC. FUNC ASSY,
MECHANISM UNIT)

SCH-3

This diagram is viewed from the mounted parts side.

To PRE. AMP assy CN3001 and MAIN assy CN2011

To I - MECHA B unit

Q1101 IC1102 G1181-G1184 IC1201 G1483 G1481 G1482 IC1202 G1253-G1255
 Q1151 IC1101 Q1152 Q1102 G1303 Q1304 IC1301 Q1305 Q1501-Q1505 Q1857 G1855 G1854 IC1401 IC1701 G1753 G1754 G1771 G1772 G1755
 Q1807 Q1351 Q1301 Q1302 Q1302 Q1305 Q1501-Q1505 Q1857 G1855 G1854 IC1401 IC1701 G1753 G1754 G1771 G1772 G1755
 G1003-G1005 IC1004 G1008 G1009 G1006 G1007 G1751 G1752

TC. MAIN ASSY

VR1181-VR1184
VR1301 VR1501 VR1302 VR1502

RNP1602-D

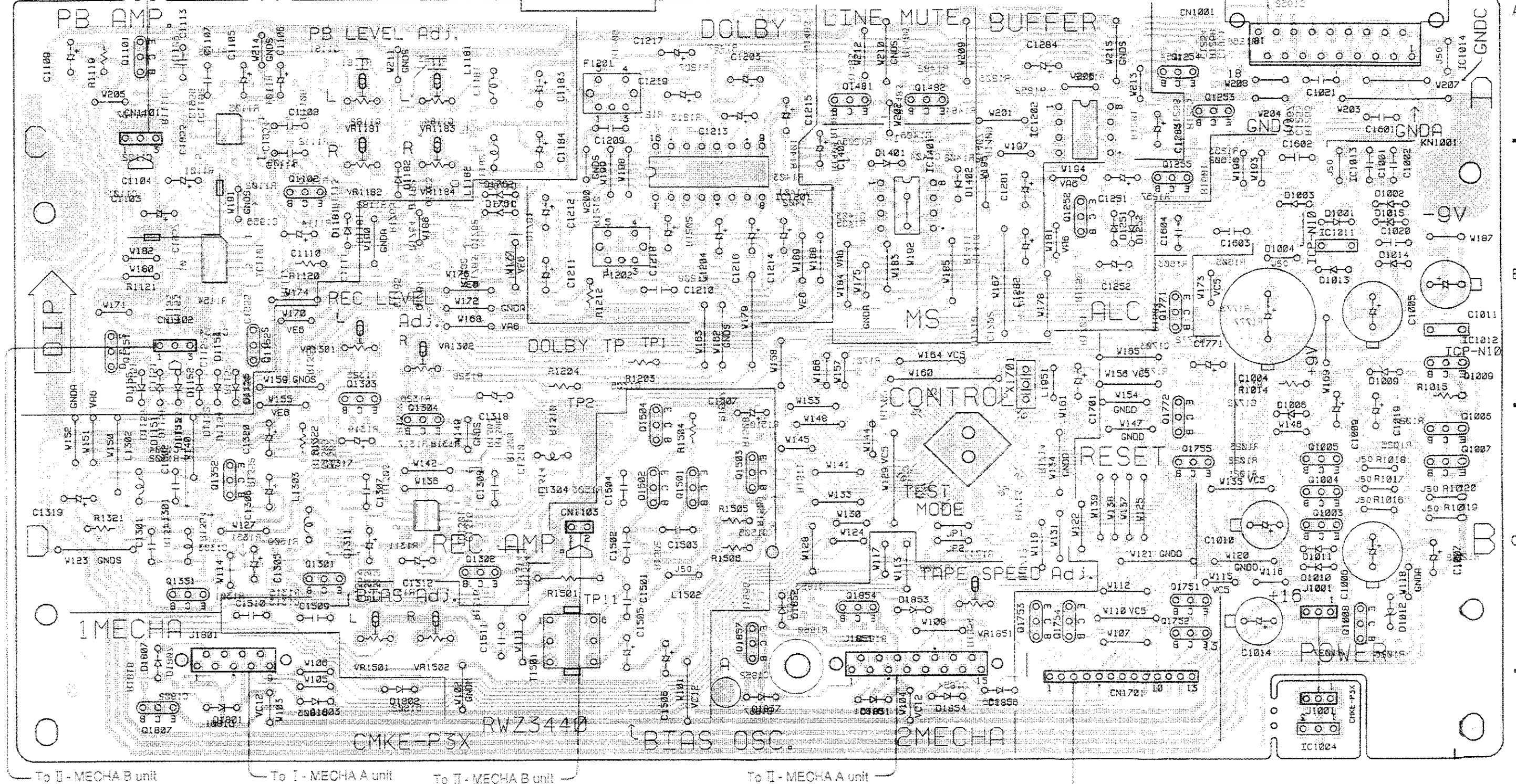

To II - MECHA B unit

To I - MECHA A unit

To II - MECHA B unit

To II - MECHA A unit

TC. FUNC ASSY

RWZ3441

CMKE-P3X

DOLBY I II REW FF STOP REC PAUSE ASES/COPY

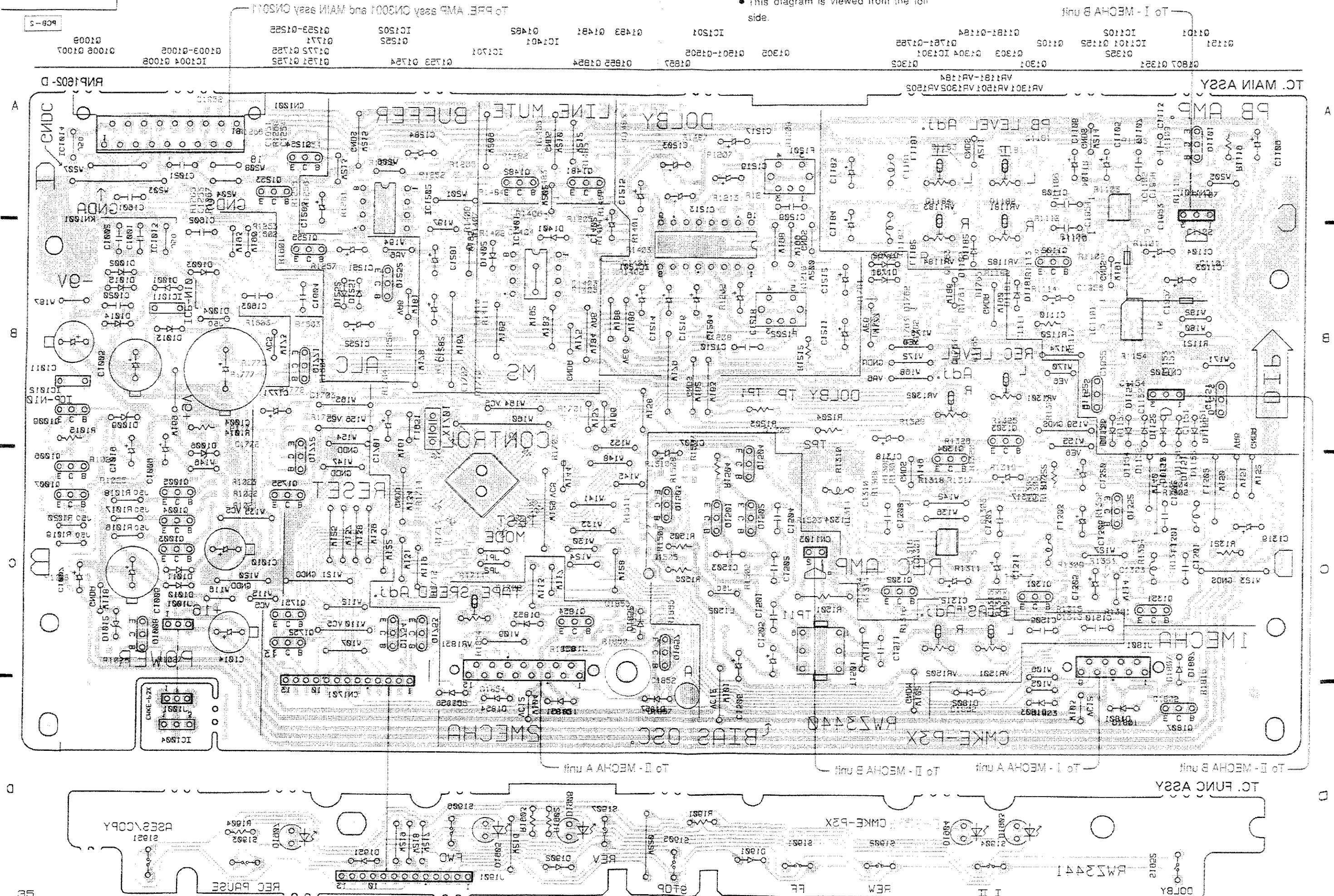

This diagram is viewed from the foil side.

IC1501 01483 01481 IC1502 01501 01501
 IC1503 01523 01522 IC1504 01465
 IC1505 01525 IC1506 01747
 IC1507 01741 IC1508 01523-01522
 IC1509 01745 IC1510 01745
 IC1511 01745 IC1512 01745
 IC1513 01745 IC1514 01745
 IC1515 01745 IC1516 01745
 IC1517 01745 IC1518 01745
 IC1519 01745 IC1520 01745
 IC1521 01745 IC1522 01745
 IC1523 01745 IC1524 01745
 IC1525 01745 IC1526 01745
 IC1527 01745 IC1528 01745
 IC1529 01745 IC1530 01745
 IC1531 01745 IC1532 01745
 IC1533 01745 IC1534 01745
 IC1535 01745 IC1536 01745
 IC1537 01745 IC1538 01745
 IC1539 01745 IC1540 01745
 IC1541 01745 IC1542 01745
 IC1543 01745 IC1544 01745
 IC1545 01745 IC1546 01745
 IC1547 01745 IC1548 01745
 IC1549 01745 IC1550 01745
 IC1551 01745 IC1552 01745
 IC1553 01745 IC1554 01745
 IC1555 01745 IC1556 01745
 IC1557 01745 IC1558 01745
 IC1559 01745 IC1560 01745
 IC1561 01745 IC1562 01745
 IC1563 01745 IC1564 01745
 IC1565 01745 IC1566 01745
 IC1567 01745 IC1568 01745
 IC1569 01745 IC1570 01745
 IC1571 01745 IC1572 01745
 IC1573 01745 IC1574 01745
 IC1575 01745 IC1576 01745
 IC1577 01745 IC1578 01745
 IC1579 01745 IC1580 01745
 IC1581 01745 IC1582 01745
 IC1583 01745 IC1584 01745
 IC1585 01745 IC1586 01745
 IC1587 01745 IC1588 01745
 IC1589 01745 IC1590 01745
 IC1591 01745 IC1592 01745
 IC1593 01745 IC1594 01745
 IC1595 01745 IC1596 01745
 IC1597 01745 IC1598 01745
 IC1599 01745 IC1600 01745
 IC1601 01745 IC1602 01745
 IC1603 01745 IC1604 01745
 IC1605 01745 IC1606 01745
 IC1607 01745 IC1608 01745
 IC1609 01745 IC1610 01745
 IC1611 01745 IC1612 01745
 IC1613 01745 IC1614 01745
 IC1615 01745 IC1616 01745
 IC1617 01745 IC1618 01745
 IC1619 01745 IC1620 01745
 IC1621 01745 IC1622 01745
 IC1623 01745 IC1624 01745
 IC1625 01745 IC1626 01745
 IC1627 01745 IC1628 01745
 IC1629 01745 IC1630 01745
 IC1631 01745 IC1632 01745
 IC1633 01745 IC1634 01745
 IC1635 01745 IC1636 01745
 IC1637 01745 IC1638 01745
 IC1639 01745 IC1640 01745
 IC1641 01745 IC1642 01745
 IC1643 01745 IC1644 01745
 IC1645 01745 IC1646 01745
 IC1647 01745 IC1648 01745
 IC1649 01745 IC1650 01745
 IC1651 01745 IC1652 01745
 IC1653 01745 IC1654 01745
 IC1655 01745 IC1656 01745
 IC1657 01745 IC1658 01745
 IC1659 01745 IC1660 01745
 IC1661 01745 IC1662 01745
 IC1663 01745 IC1664 01745
 IC1665 01745 IC1666 01745
 IC1667 01745 IC1668 01745
 IC1669 01745 IC1670 01745
 IC1671 01745 IC1672 01745
 IC1673 01745 IC1674 01745
 IC1675 01745 IC1676 01745
 IC1677 01745 IC1678 01745
 IC1679 01745 IC1680 01745
 IC1681 01745 IC1682 01745
 IC1683 01745 IC1684 01745
 IC1685 01745 IC1686 01745
 IC1687 01745 IC1688 01745
 IC1689 01745 IC1690 01745
 IC1691 01745 IC1692 01745
 IC1693 01745 IC1694 01745
 IC1695 01745 IC1696 01745
 IC1697 01745 IC1698 01745
 IC1699 01745 IC1700 01745

4.4 FM/AM DIGITAL SYNTHESIZER TUNER (F-P550RDS) ■ FM/AM TUNER MOD. (RDS)/HE (EXCEPT MEZIX/DI)

PCB-3

3

2

FM/AM TUNER MOD. (RDS)/HE

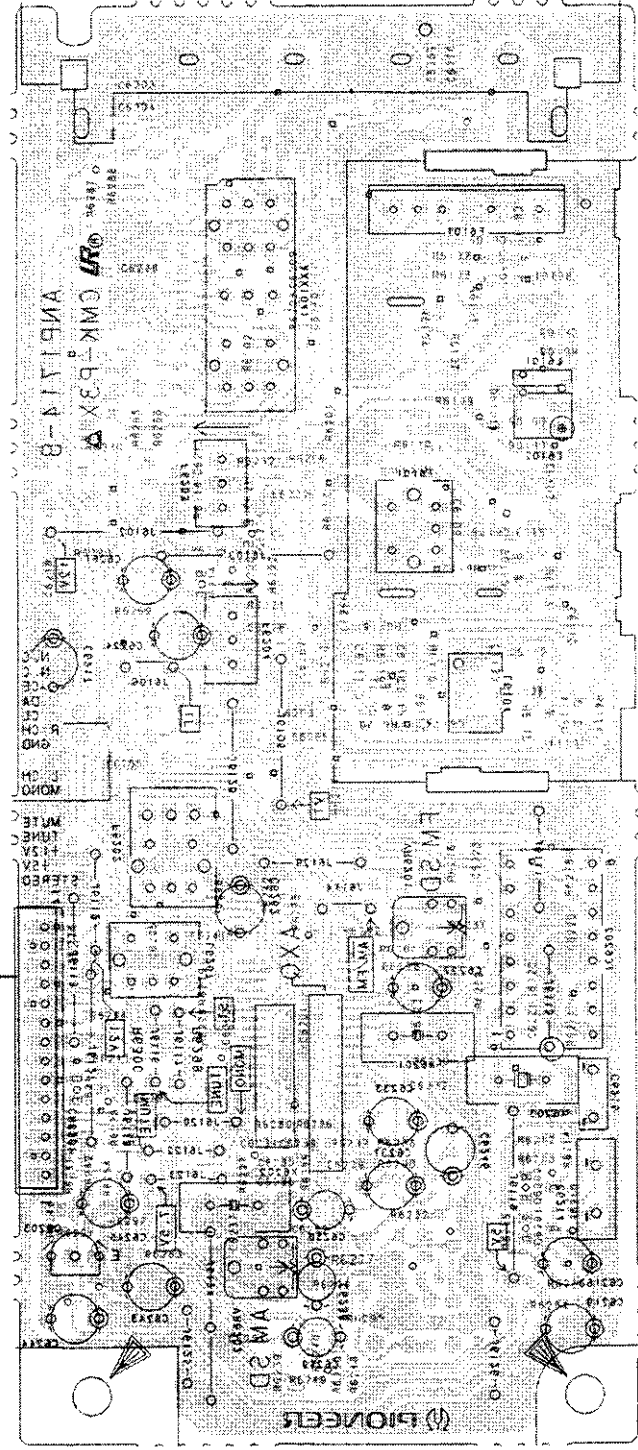

TO PRE. AMP Assy ON3103

A

B

C

D

08101

08504 08514 08105

08103 08104

AV8501 IC8505

IC8501 08513

AV8505 08505 08504 08503

• This diagram is viewed from the foil side.

3

2

4.4 FM/AM DIGITAL SYNTHESIZER TUNER (F-P550RDS)

FM/AM TUNER MOD. (RDS)/HE (Except MEZIXK/DI)

A

FM/AM TUNER MOD. (RDS)/HE

A

Q6101

Q6204

Q6102 Q6214

Q6103

Q6104

VR6201

IC6202

IC6201

Q6217

Q6202

Q6201

Q6203

VR6202

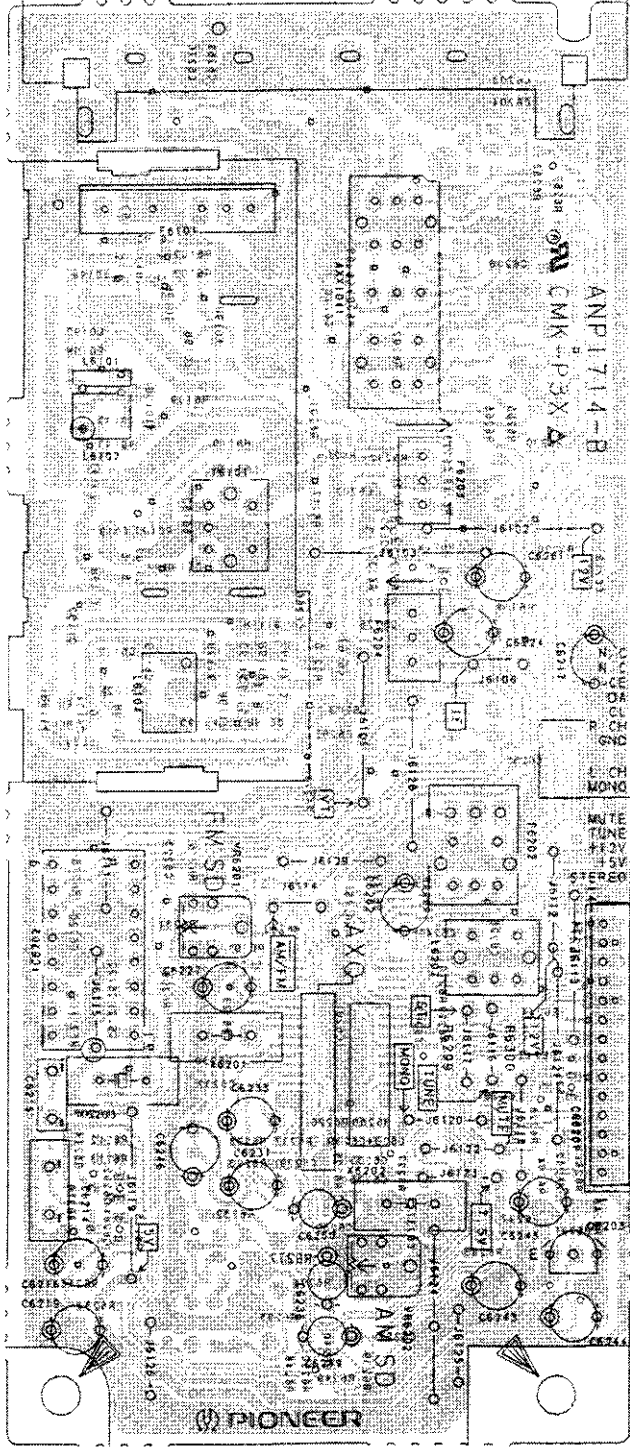

B

C

D

• This diagram is viewed from the mounted parts side.

FM/AM TUNER MOD. (RDS)/HE (AXQ7013)

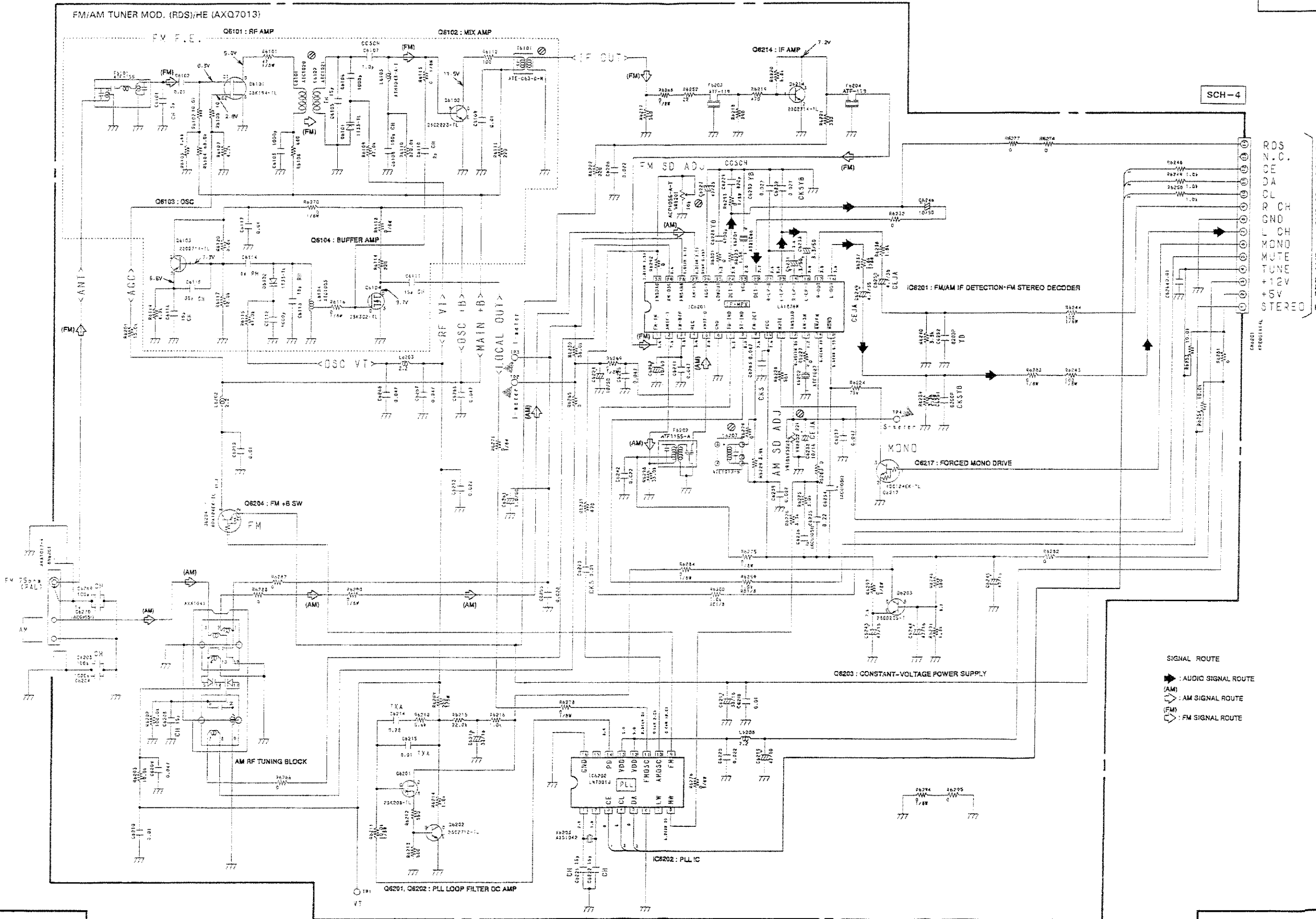

SCH-4

- RDS
 - N.C.
 - CE
 - JA
 - CL
 - R CH
 - GND
 - L CH
 - MONO
 - MUTE
 - TUNE
 - +12V
 - +5V
 - STEREO
- To PRE. AMP assy CN3103 (SCH-6)

- SIGNAL ROUTE
- ▶ : AUDIO SIGNAL ROUTE
 - (AM) : AM SIGNAL ROUTE
 - (FM) : FM SIGNAL ROUTE

SCH-4

FM/AM DIGITAL SYNTHESIZER TUNER (F-P550RDS)
(FM/AM TUNER MOD. (RDS)/HE)

FM/AM DIGITAL SYNTHESIZER TUNER (F-P550RDS)
(FM/AM TUNER MOD. (RDS)/HE)

SCH-4

FM/AM TUNER MOD. (RDS)/HEZ (MEZIXK/DI type)

A
B
C
D

A
B
C
D

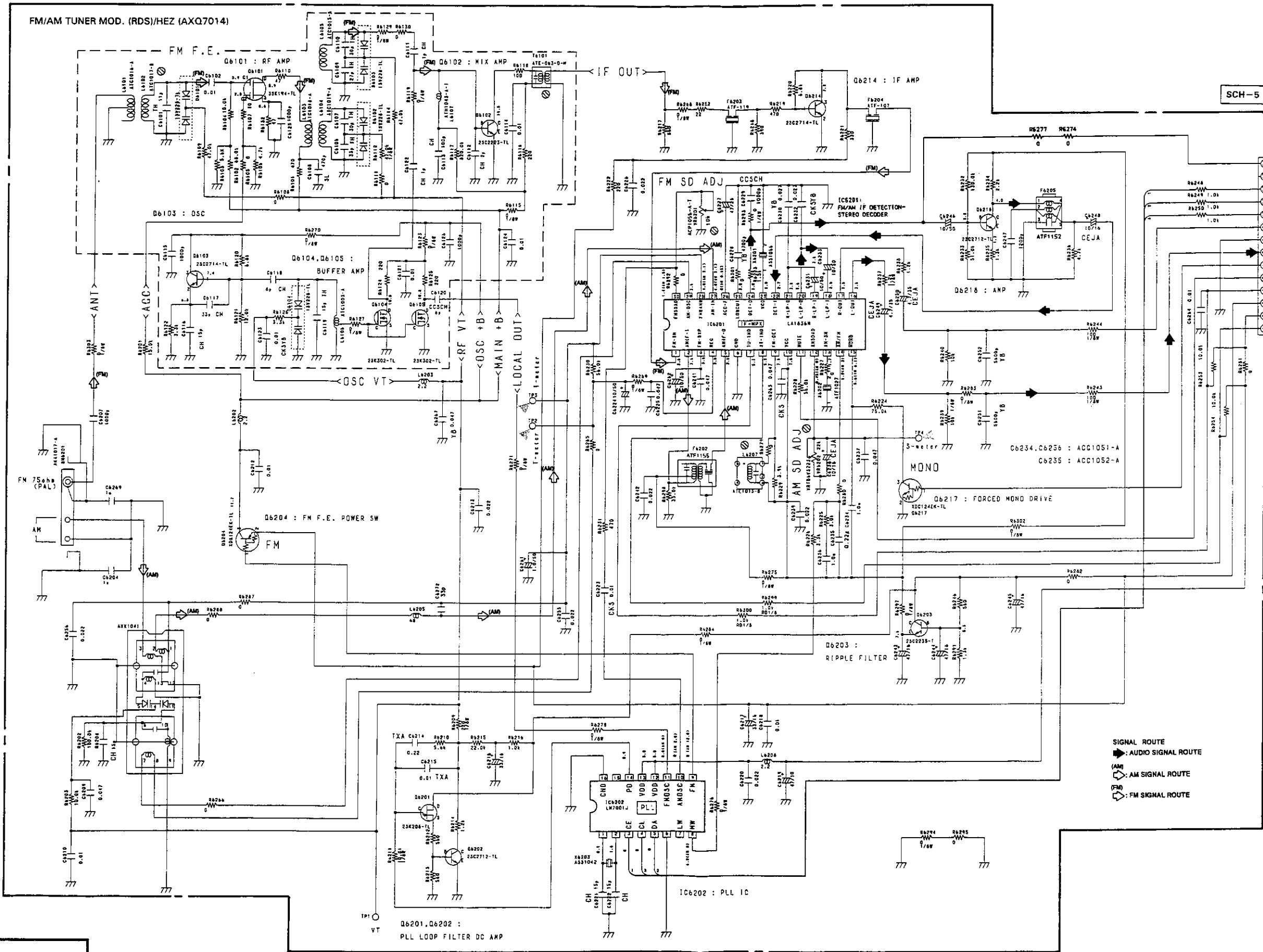

N.C. (RDS)
N.C.
CE
DA
CL
R CH
GND
L CH
MONO
MUTE
TUNE
+12V
+5V
STEREO

To PRE. AMP assy CN3103 (SCH-6)

SCH-5

FM/AM DIGITAL SYNTHESIZER TUNER (F-P550RDS)
(FM/AM TUNER MOD. (RDS)/HEZ)

FM/AM DIGITAL SYNTHESIZER TUNER (F-P550RDS)
(FM/AM TUNER MOD. (RDS)/HEZ)

SCH-5

FM/AM TUNER MOD. (RDS)/HEZ

A

Q6101

B

Q6204

Q6102

Q6214

Q6104

Q6103

Q6105

C

IC5202

VR6201

IC5201

Q6217

Q6202

Q6201

Q6218

Q6203

VR6202

D

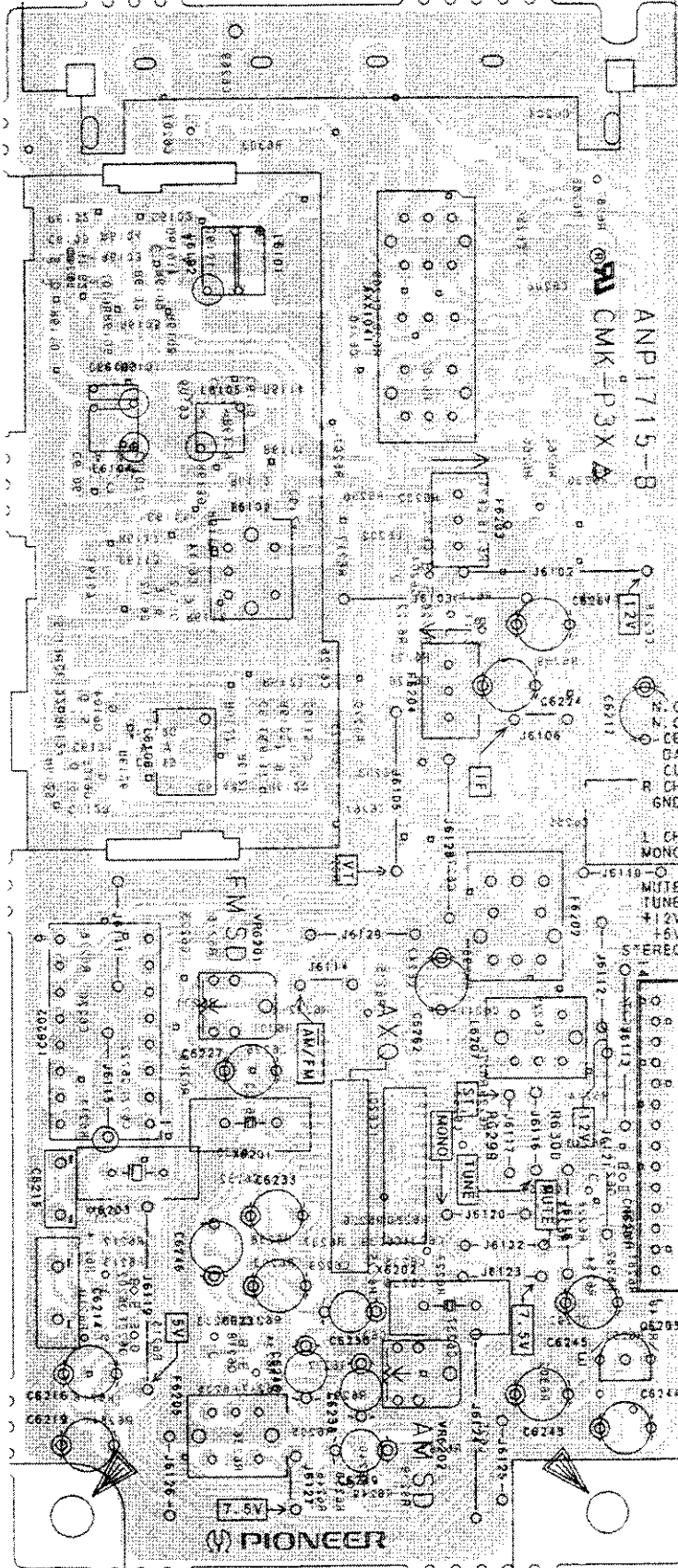

• This diagram is viewed from the mounted parts side.

FM/AM TUNER MOD. (RDS)/HEZ

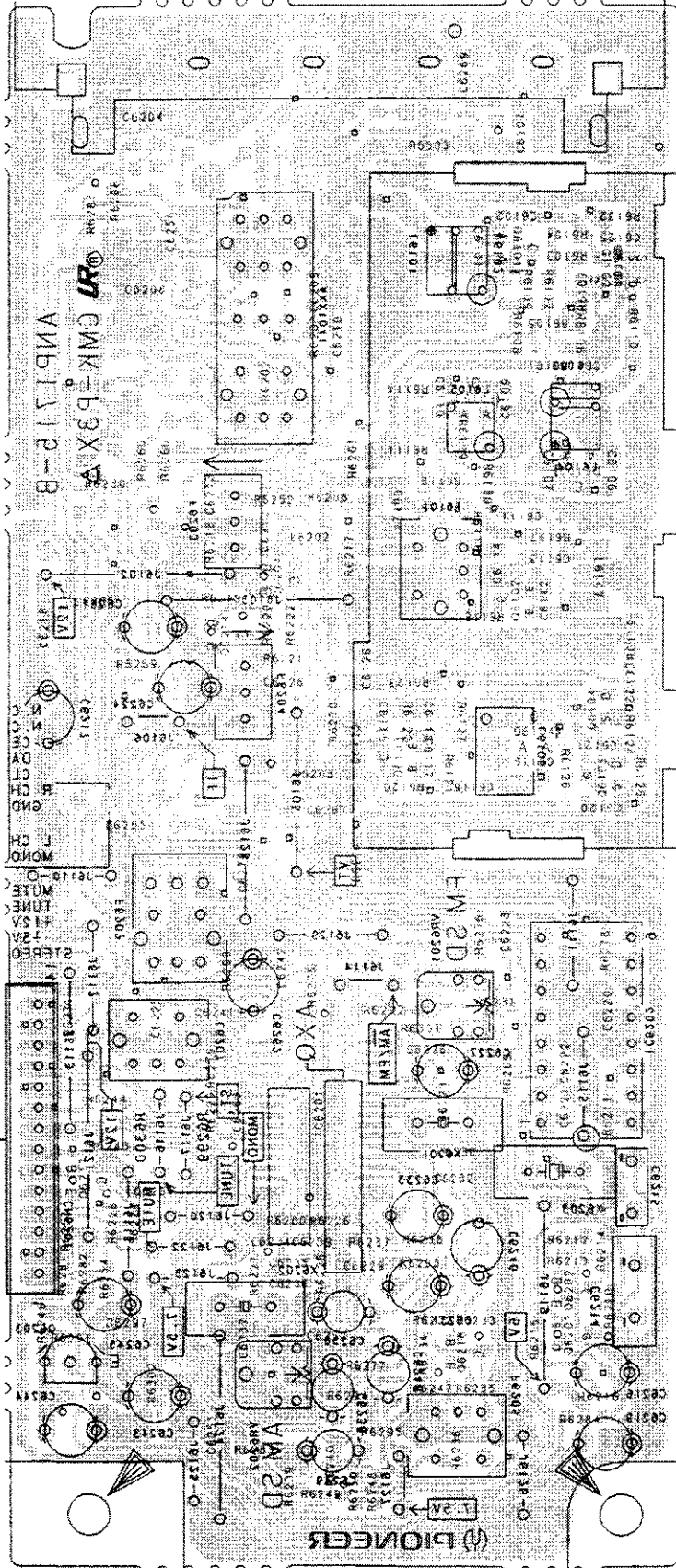

• This diagram is viewed from the foil side.

TO PRE. AMP assy CN3103

08101

08504

08105

08514

08104

08103

08102

AVR501

C IC505

IC501

08517

08505

08501

08516

AVR505

PRE. AMP ASSY AND DISPLAY ASSY

To CD MAIN Assy CN11

To MAIN Assy CN5011 and TC MAIN Assy CN1001

This diagram is viewed from the foil side.

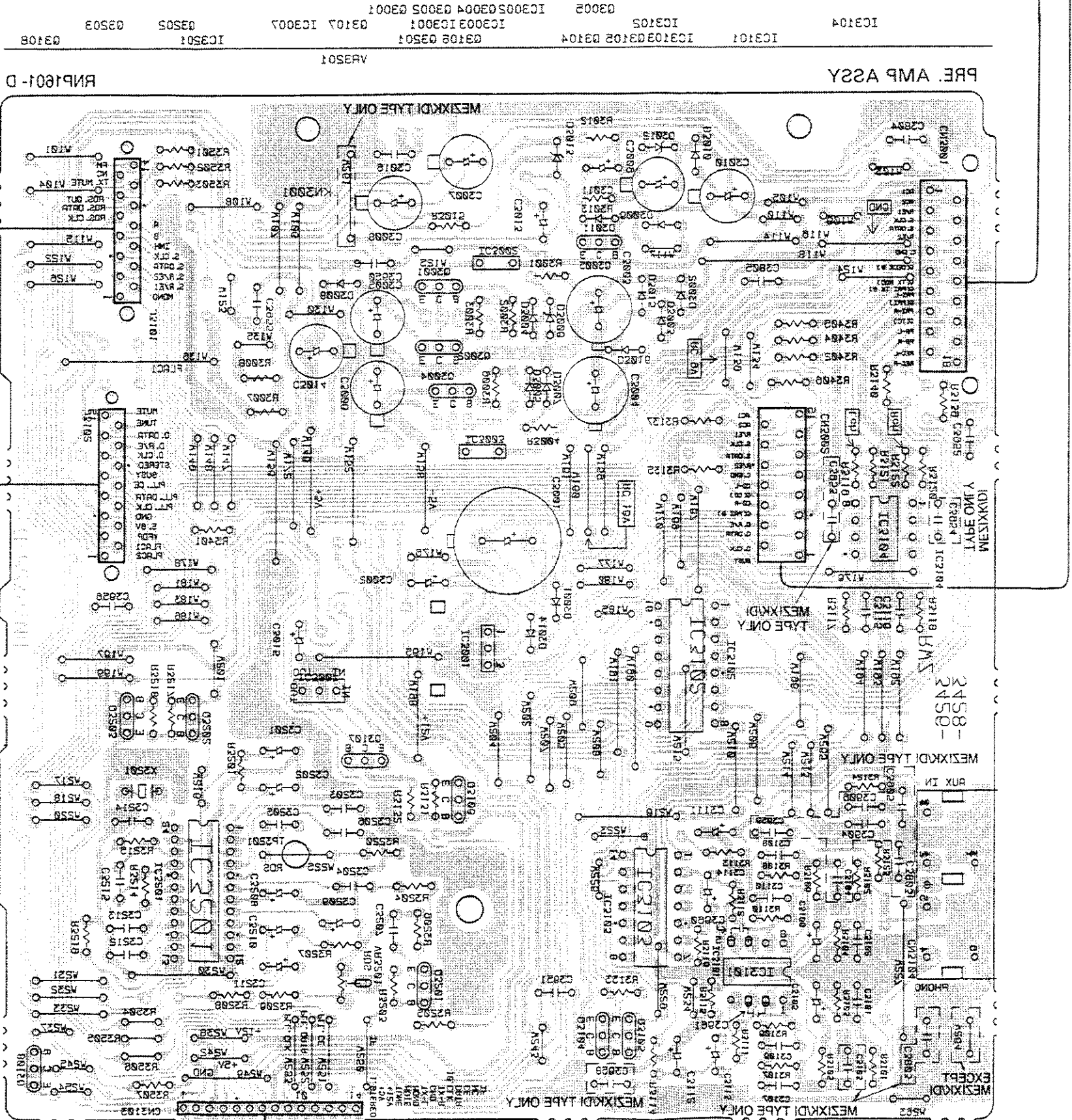

To FMW TUNER MOD. CN8501

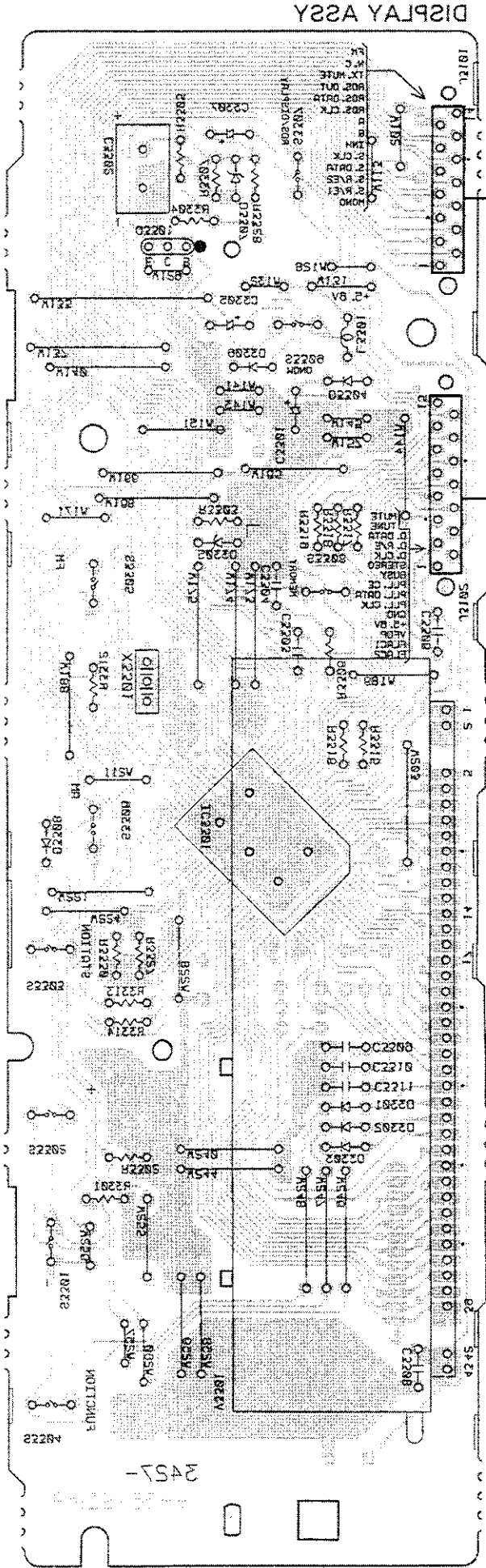

IC3301

IC3301

3451-

PRE. AMP ASSY AND DISPLAY ASSY

This diagram is viewed from the mounted parts side.

DISPLAY ASSY

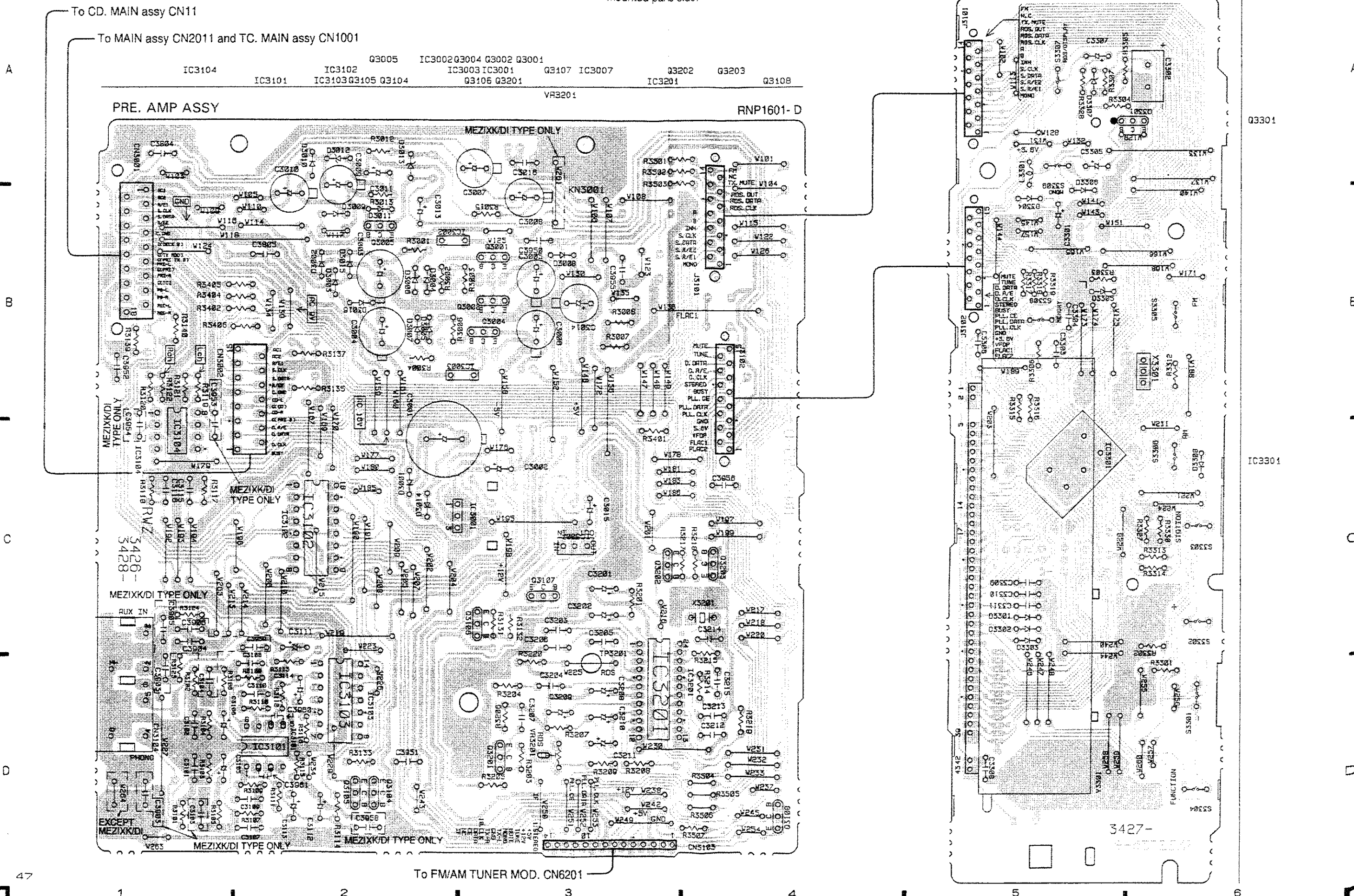

A
B
C
D
E
F

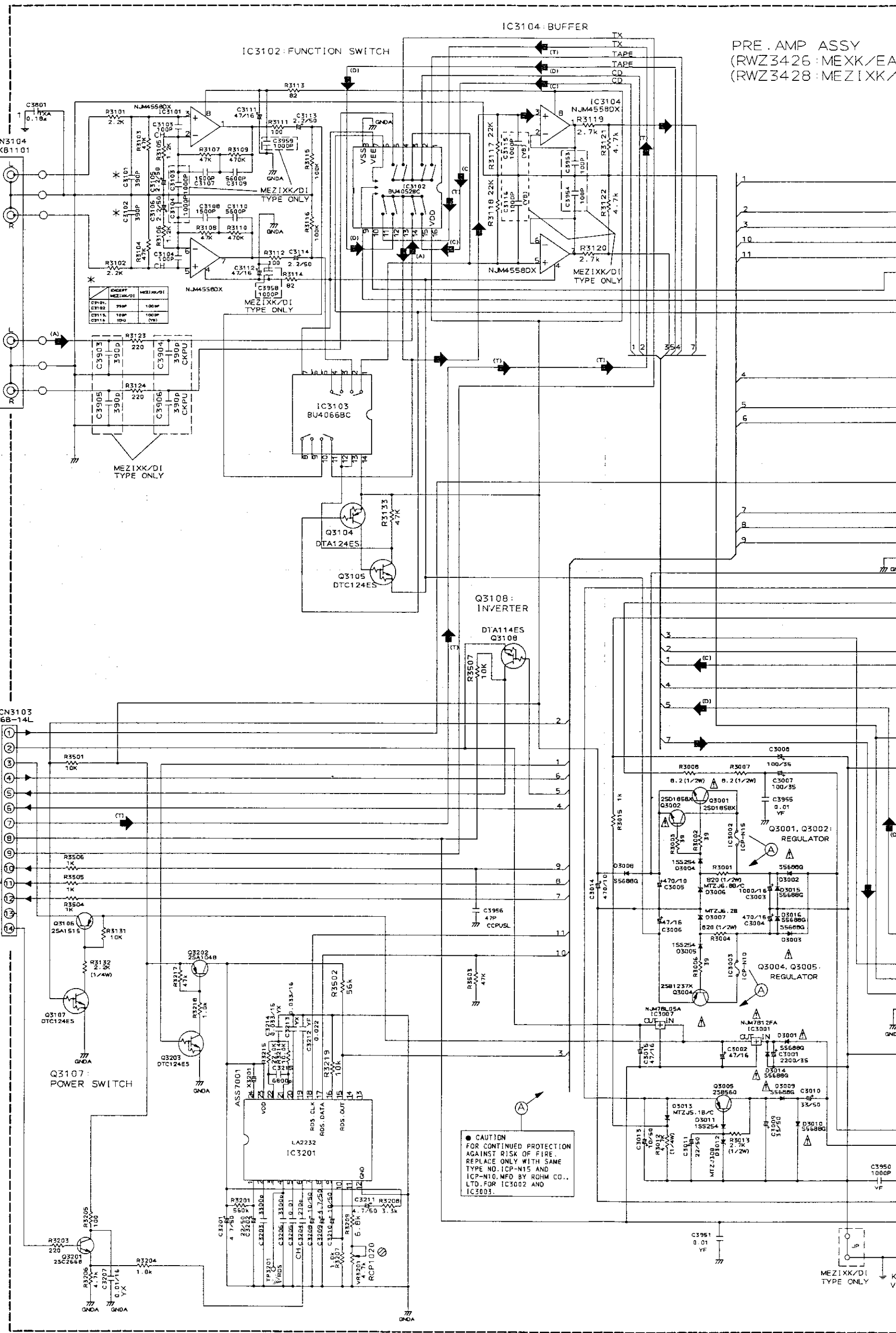

SCH-6

FM/AM DIGITAL SYNTHESIZER TUNER (F--P550RDS)
(PRE. AMP ASSY, DISPLAY ASSY)

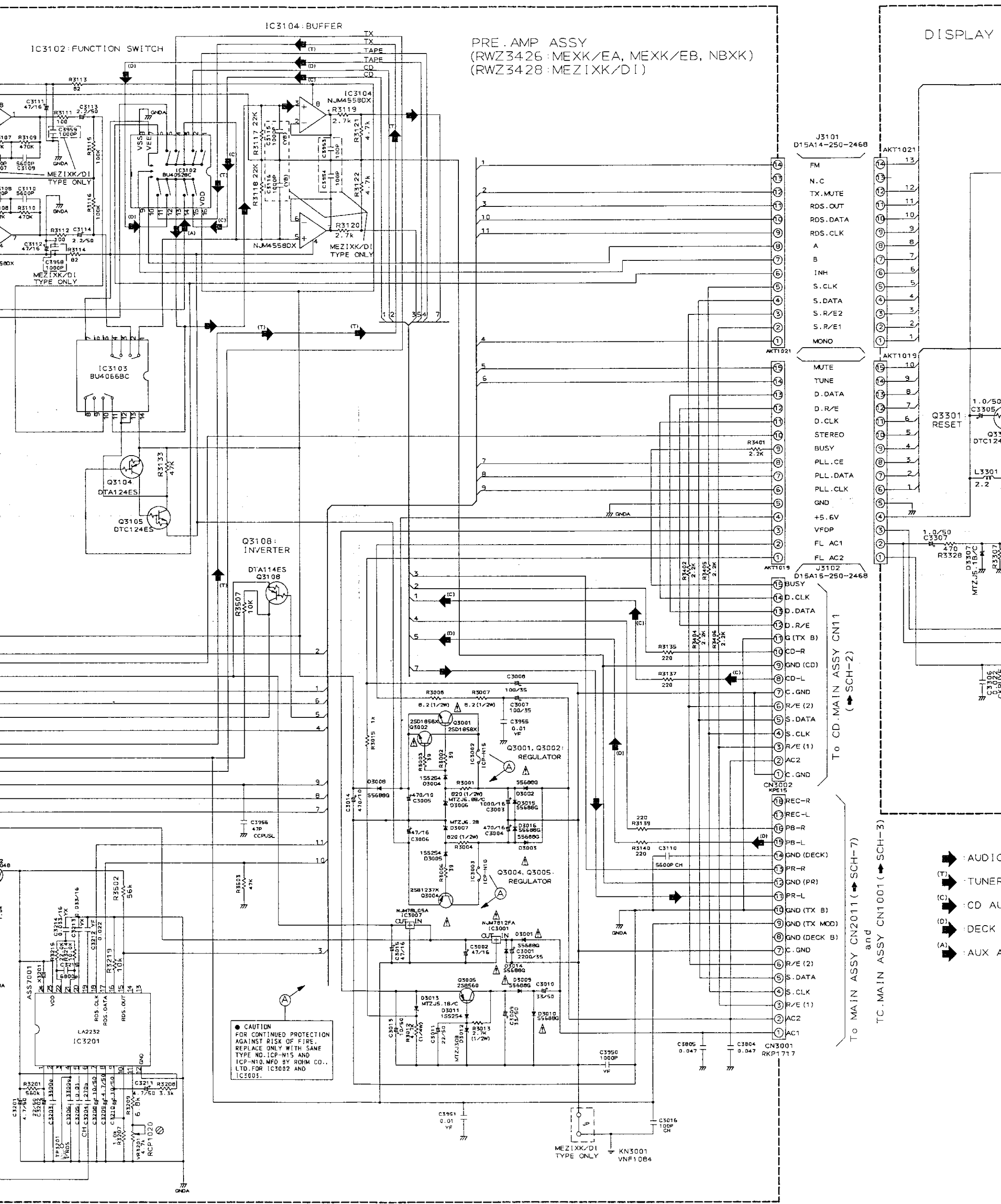

ZER TUNER (F-P550RDS) ASSY)

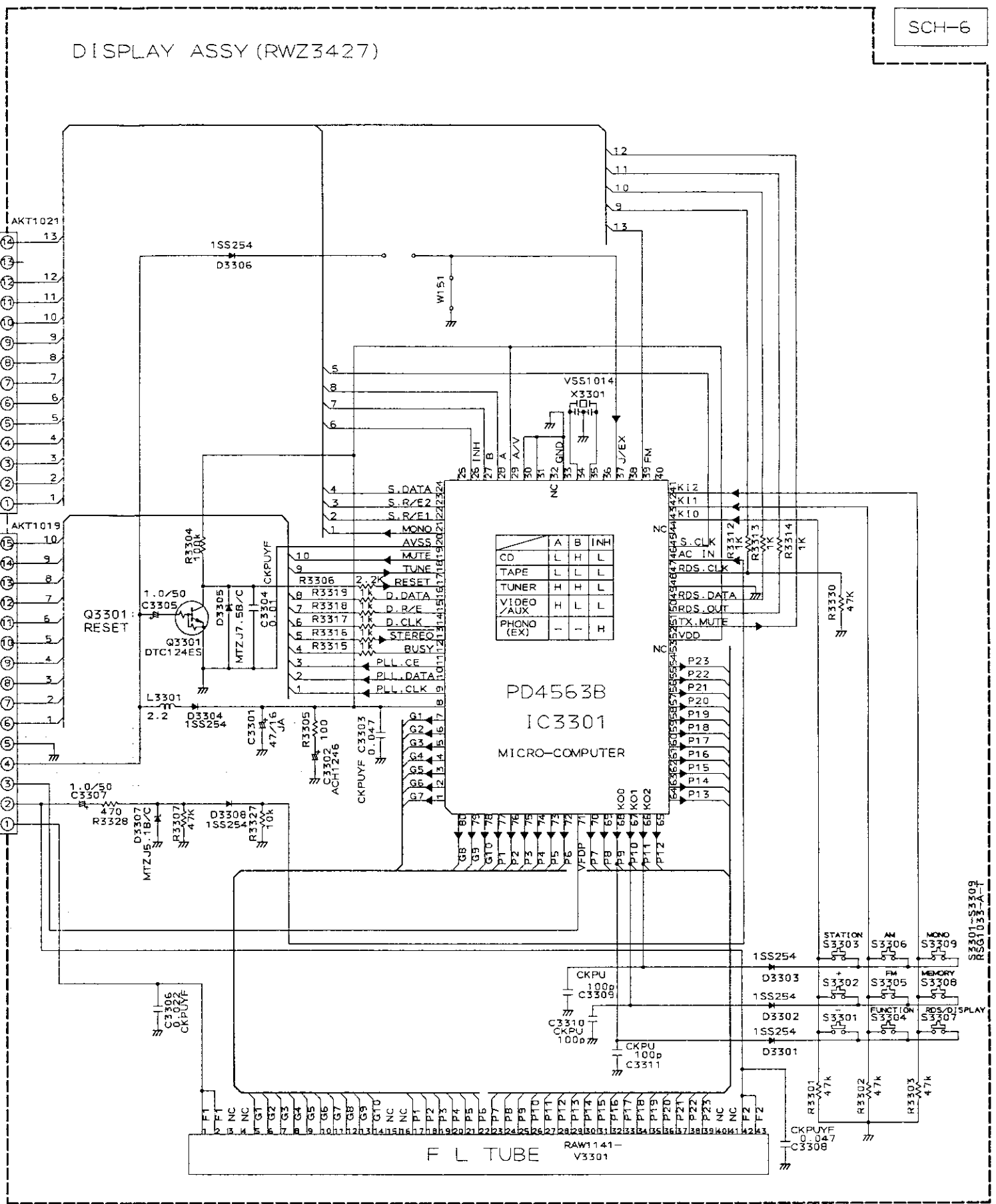
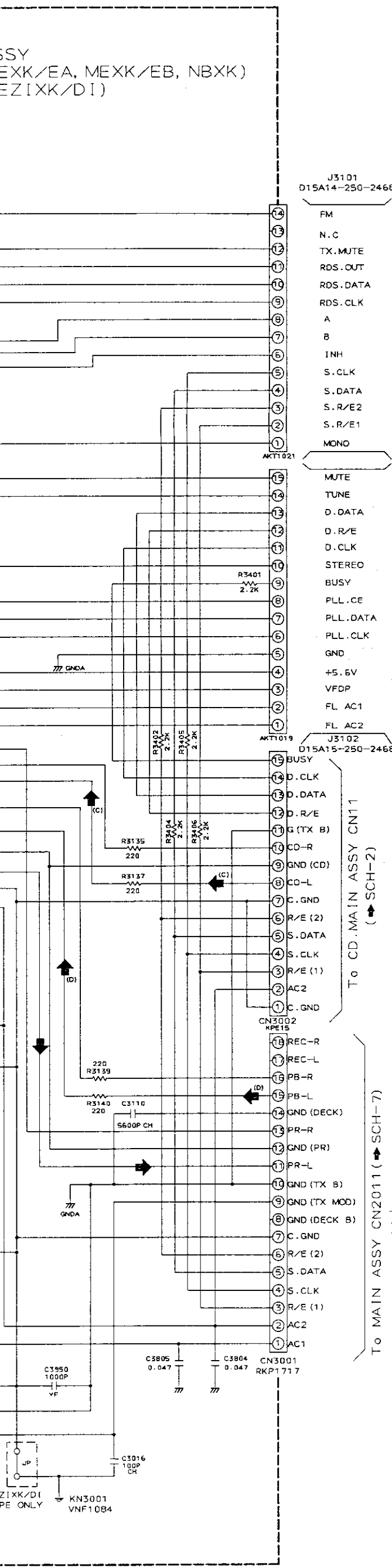

- (T) AUDIO SIGNAL
- (T) TUNER AUDIO SIGNAL
- (C) CD AUDIO SIGNAL
- (D) DECK PB SIGNAL
- (A) AUX AUDIO SIGNAL

IC3201 LA2232

PIN NO.	VOLTAGE [V]	PIN NO.	VOLTAGE [V]
1	1.5	13, 14	NC
2	1.4	15	4.8 (RDS IND ON)
3	NC	16	0
4	1.4	17	2.5 (DATA)
5	2.5	18	1.8 (CLOCK)
6	2.4	19	1.7 (1.7)
7	2.8	20	1.1
8	1.3	21	2.1
9	1.4	22	2.1
10	0.6	23	4.7
11	0.7	24	3.2 (CLOCK)
12	0 (GND)		

4.5 STEREO AMPLIFIER (A-P550)

■ DISPLAY ASSY, MAIN ASSY, H. P ASSY, SFC ASSY, CONNECT ASSY, AC. CONNECT ASSY AND SP. OUT ASSY

A

B

C

D

E

F

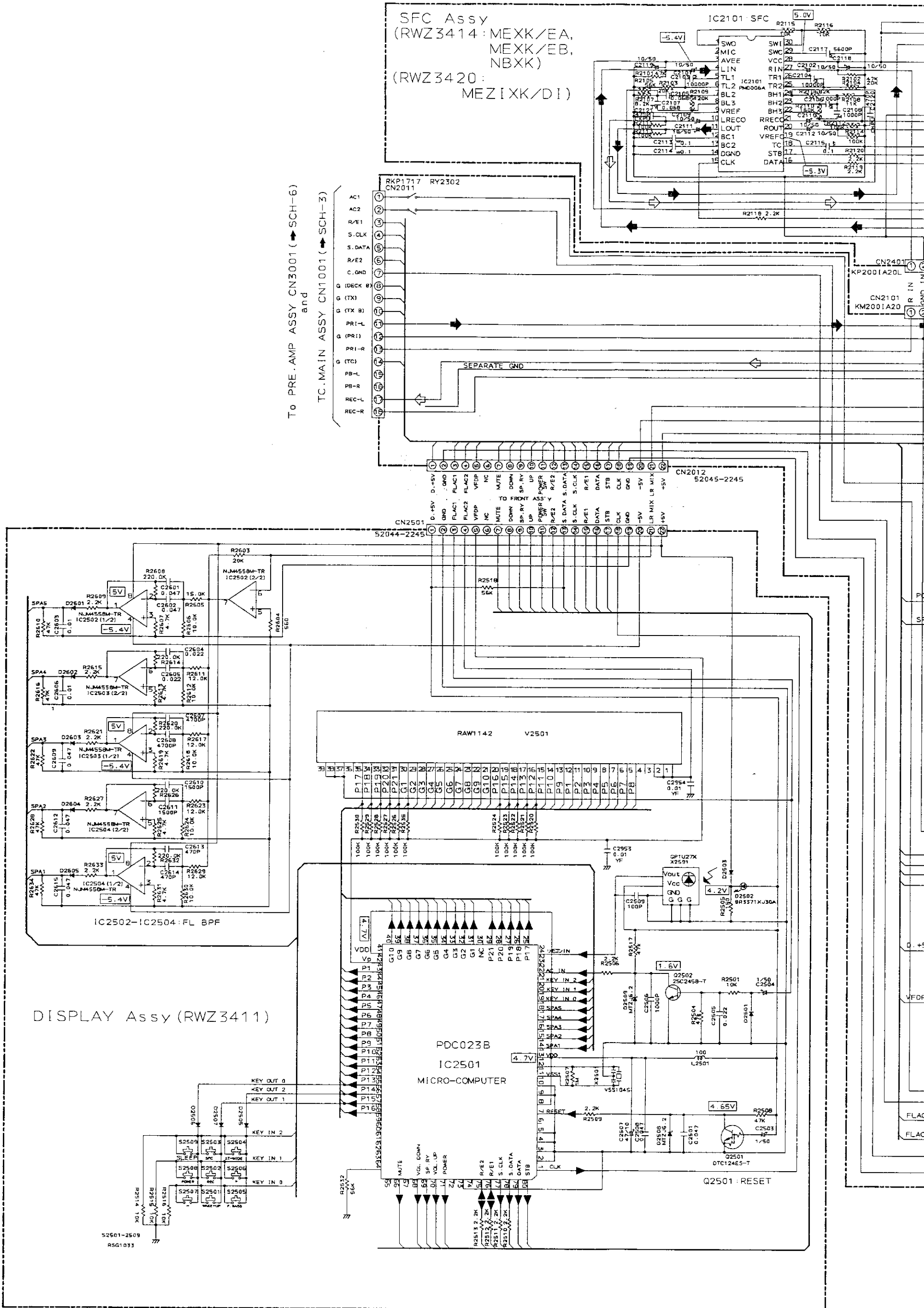

SCH-7

STEREO AMPLIFIER (A-P550)
(DISPLAY ASSY, MAIN ASSY, H.P ASSY,
SFC ASSY, CONNECT ASSY,
AC. CONNECT ASSY, SP. OUT ASSY)

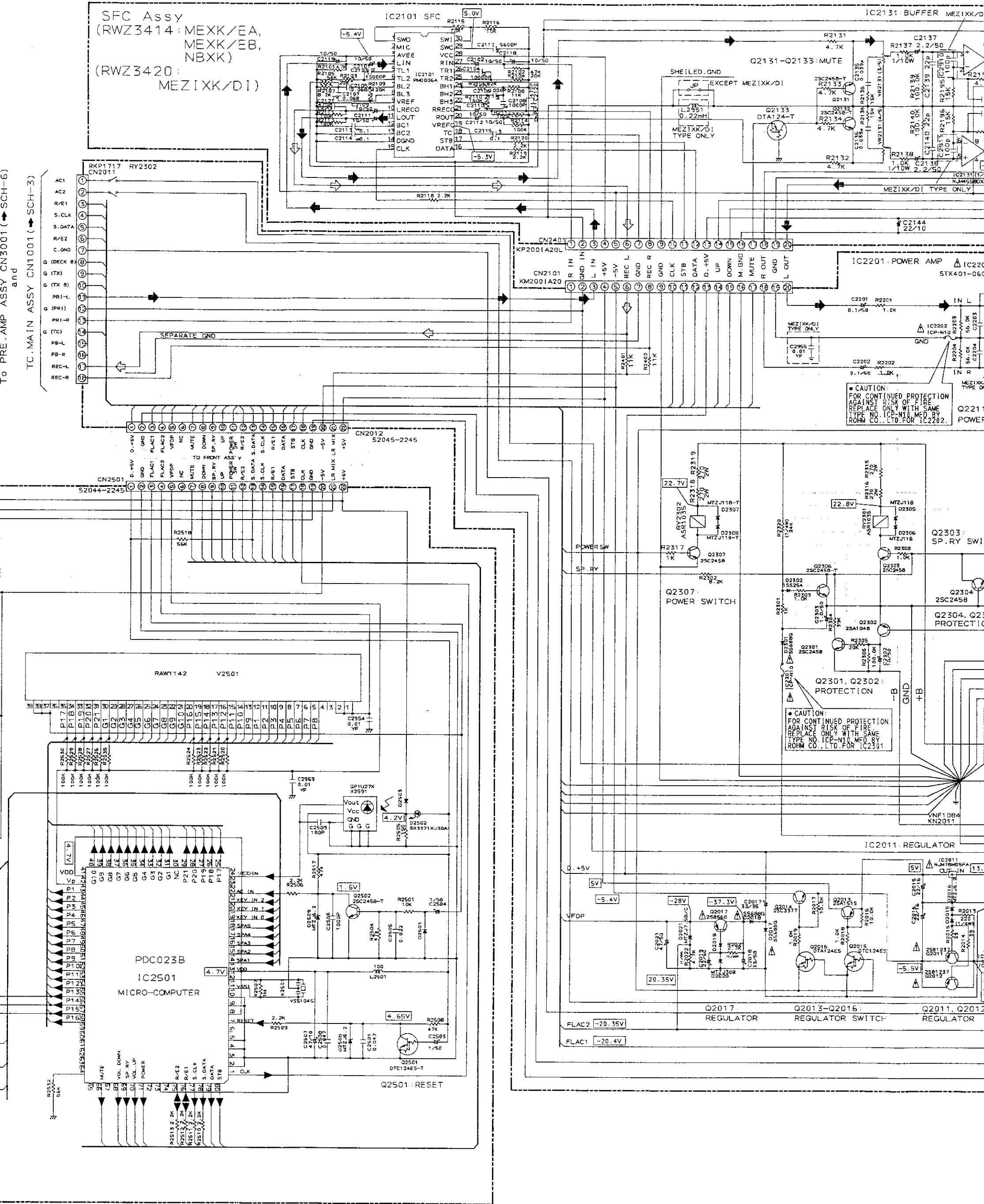

CAUTION:
FOR CONTINUED PROTECTION
AGAINST RISK OF FIRE
REPLACE ONLY WITH SAME
TYPE NO. ICP-N10 MFG BY
ROHM CO., LTD. FOR IC2201.

CAUTION:
FOR CONTINUED PROTECTION
AGAINST RISK OF FIRE
REPLACE ONLY WITH SAME
TYPE NO. ICP-N10 MFG BY
ROHM CO., LTD. FOR IC2301.

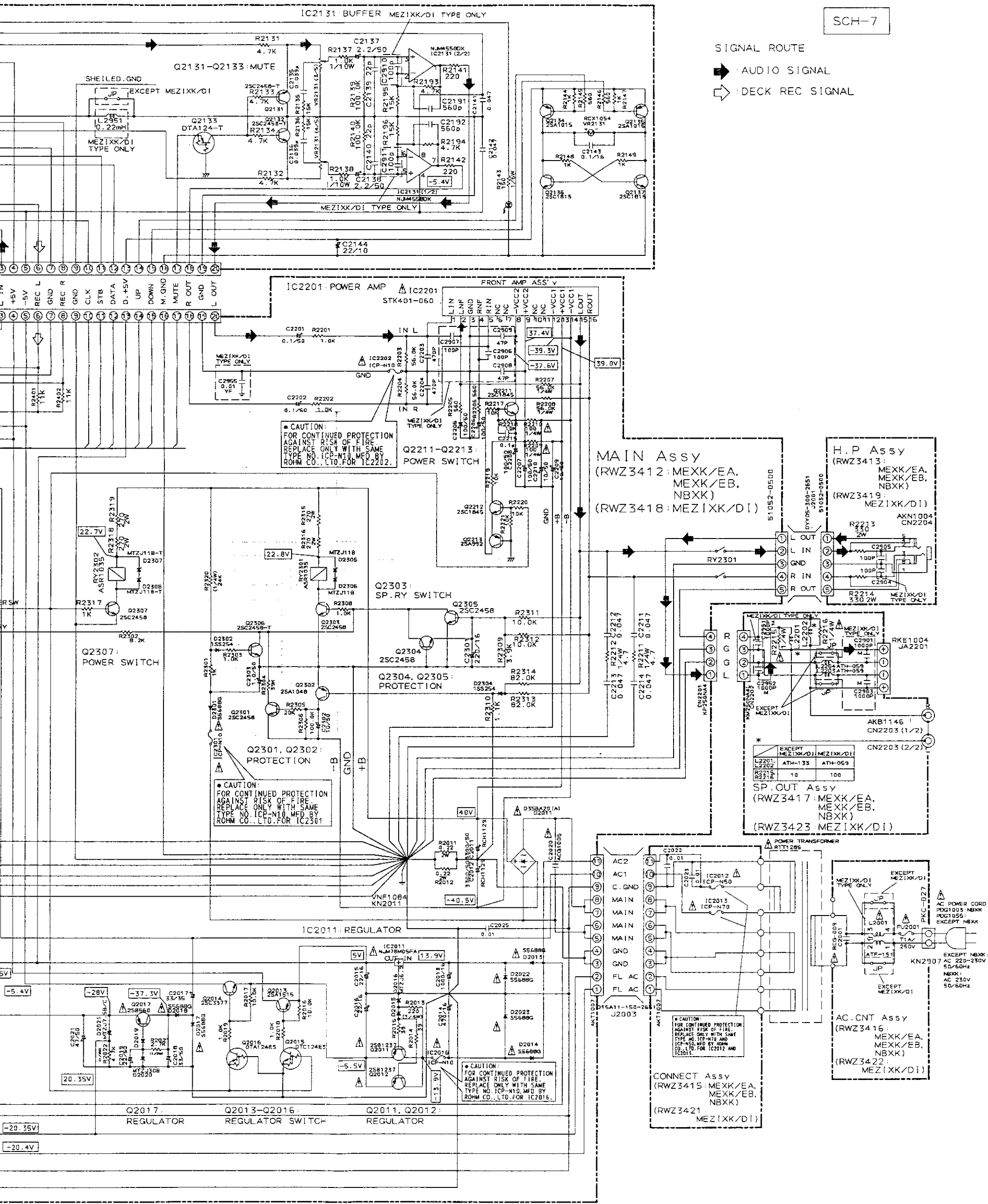

A
B
C
D
E
F

STEREO AMPLIFIER (A-P550)
 (DISPLAY ASSY, MAIN ASSY, H.P. ASSY,
 SFC ASSY, CONNECT ASSY,
 AC. CONNECT ASSY, SP. OUT ASSY)

SCH-7

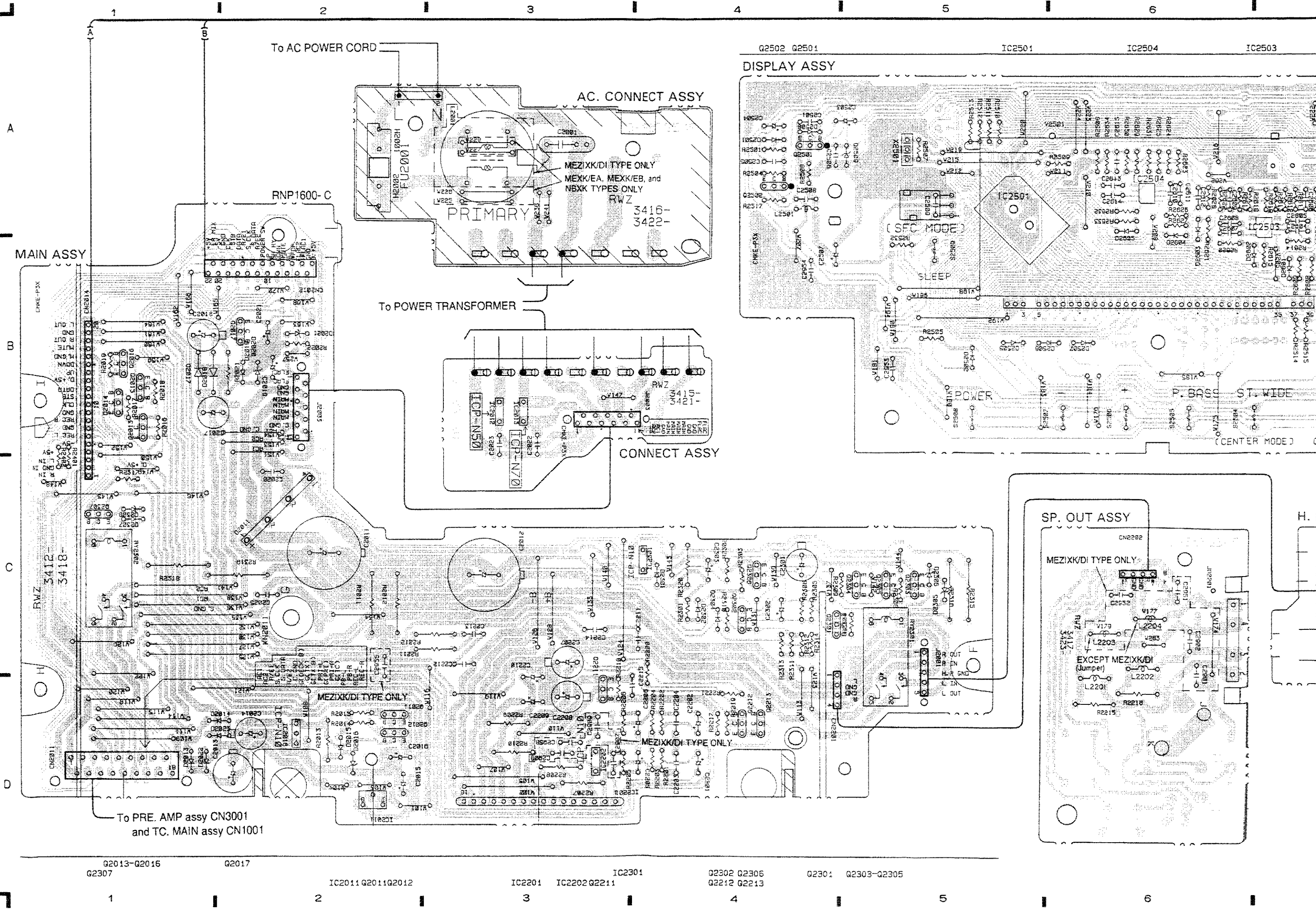

To AC POWER CORD

AC. CONNECT ASSY

MEZIXK/DI TYPE ONLY
MEXK/EA, MEXK/EB, and
NBXK TYPES ONLY
RWZ

3416-
3422-

PRIMARY

To POWER TRANSFORMER

CONNECT ASSY

Q2502 Q2501
DISPLAY ASSY

IC2501

IC2504

IC2503

POWER

SP. OUT ASSY

MEZIXK/DI TYPE ONLY

EXCEPT MEZIXK/DI
(Jumper)
L2203
L2202
L2201
R2218
R2215

To PRE. AMP assy CN3001
and TC. MAIN assy CN1001

Q2013-Q2016
Q2307

Q2017

IC2011 Q2011 Q2012

IC2201 IC2202 Q2211

IC2301

Q2302 Q2306
Q2212 Q2213

Q2301 Q2303-Q2305

1

2

3

4

5

6

3 4 5 6 7 8 9

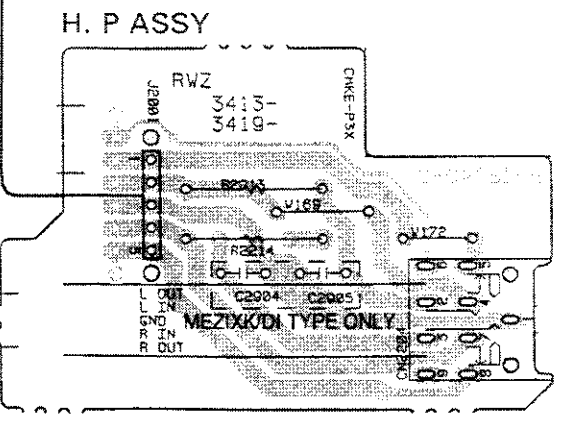
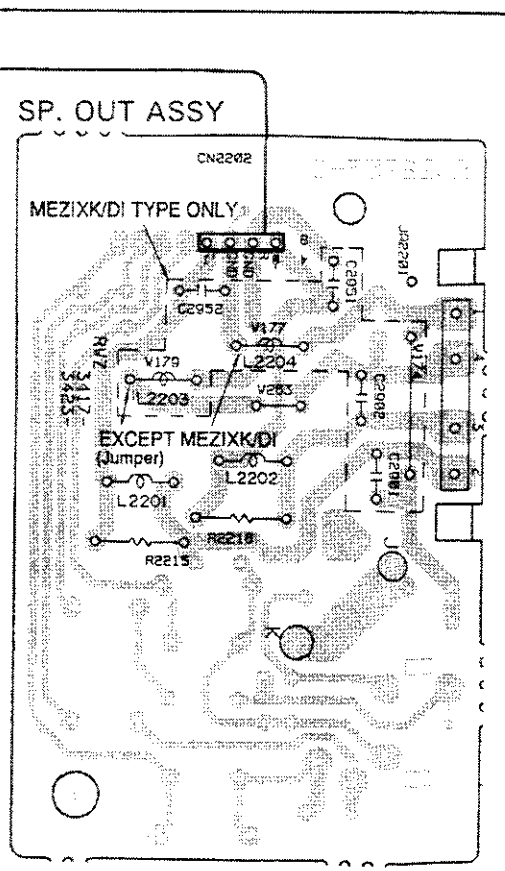
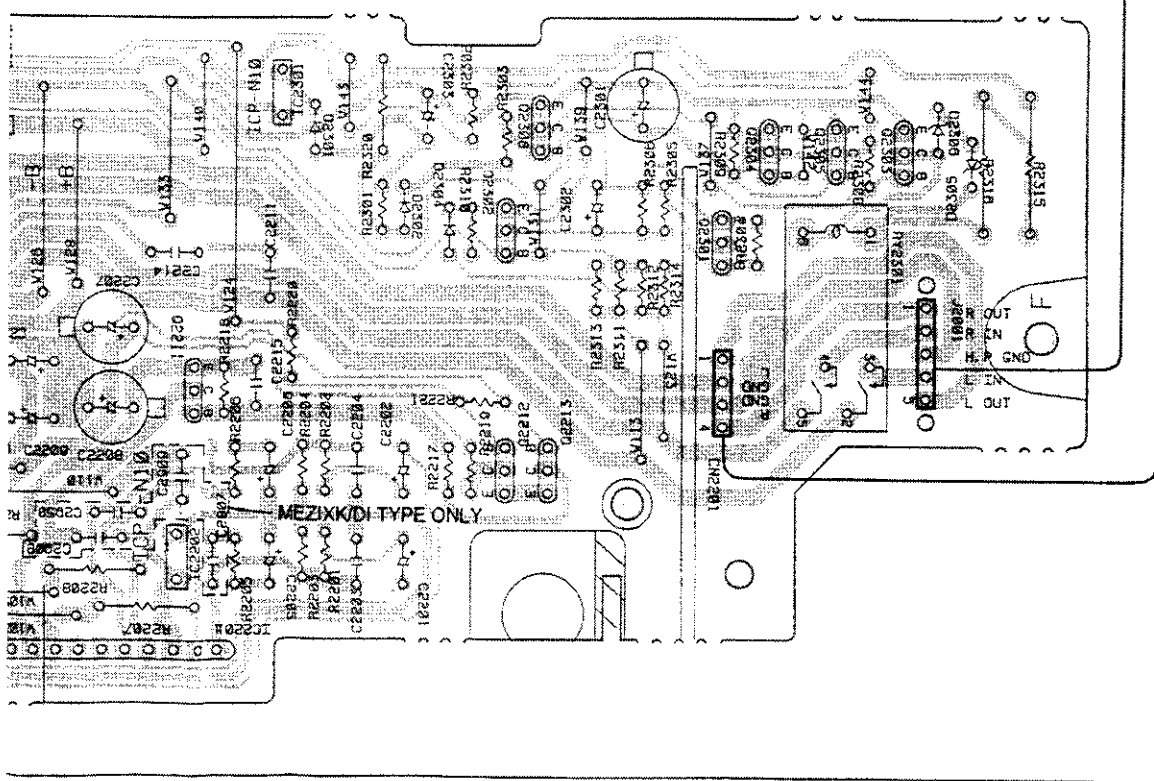
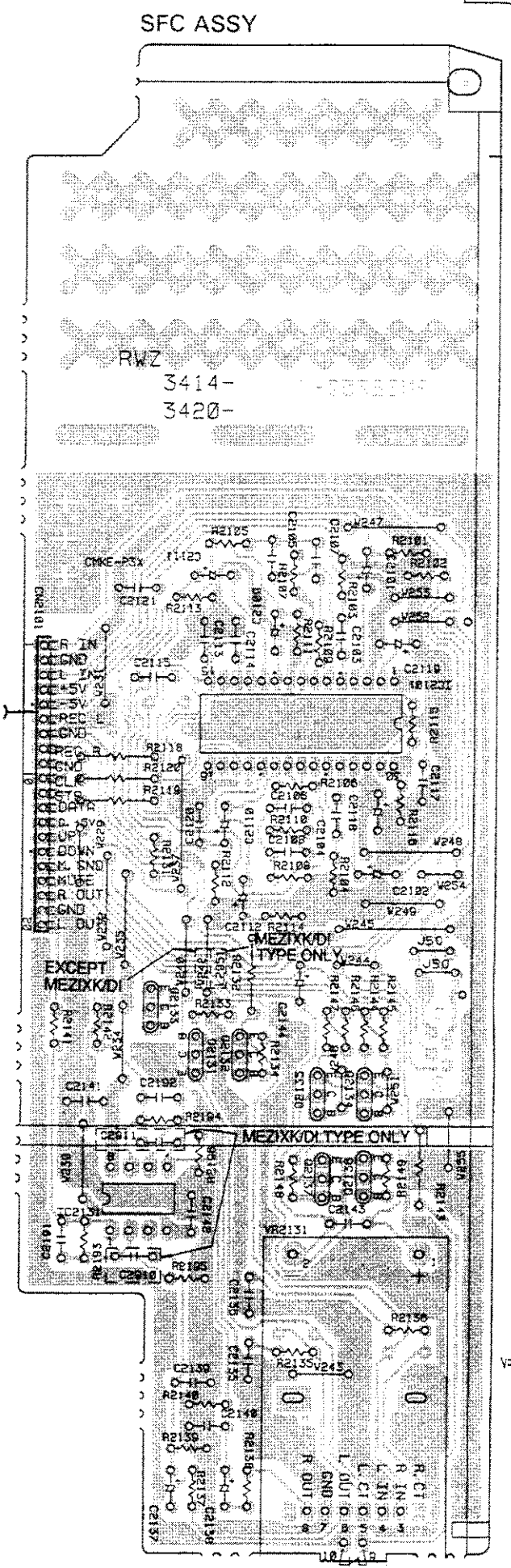
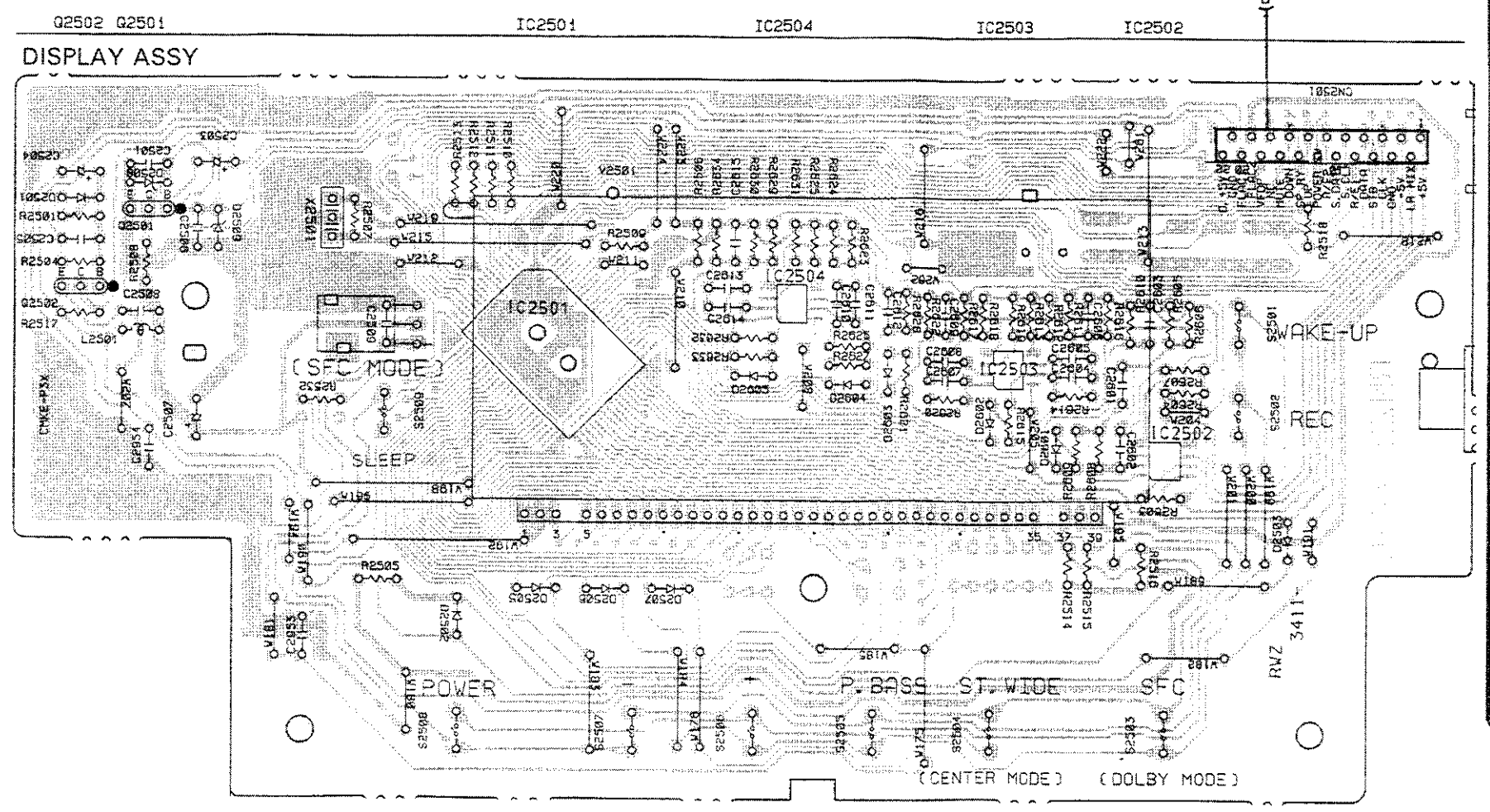
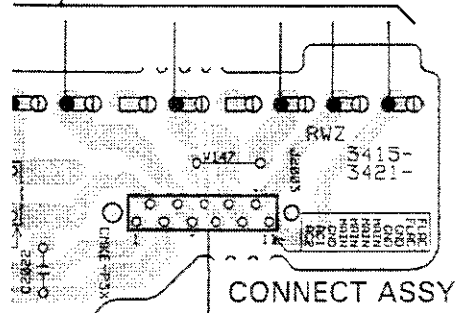
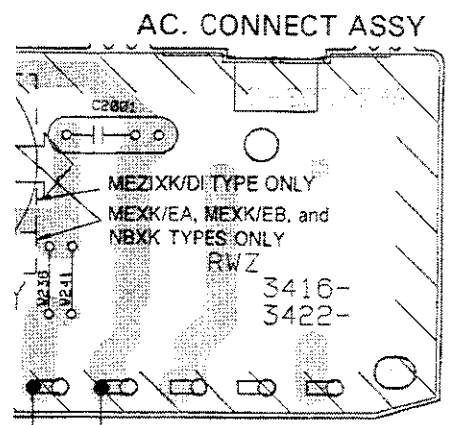

• This diagram is viewed from the mounted parts side.

2201 IC2202 Q2211 IC2301 Q2302 Q2306 Q2212 Q2213 Q2301 Q2303-Q2305 3 4 5 6 7 8 9

5. PCB PARTS LIST

NOTES :

- Parts marked by "NSP" are generally unavailable because they are not in our Master Spare Parts List.
- The Δ mark found on some component parts indicates the importance of the safety factor of the part. Therefore, when replacing, be sure to use parts of identical designation.
- Parts marked by "◎" are not always kept in stock. Their delivery time may be longer than usual or they may be unavailable.
- When ordering resistors, first convert resistance values into code form as shown in the following examples.

Ex. 1 When there are 2 effective digits (any digit apart from 0), such as 560 ohm and 47k ohm (tolerance is shown by J = 5%, and K = 10%).

560Ω → 56 × 10¹ → 561 RD1/8PM 5 6 1 J
 47kΩ → 47 × 10³ → 473 RD1/4PS 4 7 3 J
 0.5Ω → 0R5 RN2H 0 R 5 K
 1Ω → 010 RS1P 0 1 0 K

Ex. 2 When there are 3 effective digits (such as in high precision metal film resistors).

5.62kΩ → 562 × 10¹ → 5621 RM1/4PC 5 6 2 1 F

LIST OF WHOLE PCB ASSEMBLIES

Mark	Symbol & Description	Part No.				Remarks
		MEXK/EA	MEXK/EB	MEZIXK/DI	NBXK	
NSP	STEREO AMPLIFIER (A - P550)	RXF1031	RXF1038	RXF1033	RXF1027	
NSP	└ SFC. AMP assy	RWM1782	RWM1782	RWM1783	RWM1782	
	└ DISPLAY assy	RWZ3411	RWZ3411	RWZ3411	RWZ3411	
	└ MAIN assy	RWZ3412	RWZ3412	RWZ3418	RWZ3412	
NSP	└ H. P assy	RWZ3413	RWZ3413	RWZ3419	RWZ3413	
	└ SFC assy	RWZ3414	RWZ3414	RWZ3420	RWZ3414	
NSP	└ CONNECT assy	RWZ3415	RWZ3415	RWZ3421	RWZ3415	*1
	└ AC. CONNECT assy	RWZ3416	RWZ3416	RWZ3422	RWZ3416	
NSP	└ SP. OUT assy	RWZ3417	RWZ3417	RWZ3423	RWZ3417	
NSP	FM/AM DIGITAL SYNTHESIZER TUNER (F - P550RDS)	RXF1028	RXF1028	RXF1034	RXF1028	
	└ FM/AM TUNER MOD. (RDS)/HE	AXQ7013	AXQ7013	Not used	AXQ7013	
	└ FM/AM TUNER MOD. (RDS)/HEZ	Not used	Not used	AXQ7014	Not used	*2
NSP	└ PRE. TX assy	RWM1786	RWM1786	RWM1787	RWM1786	
	└ PRE. AMP assy	RWZ3426	RWZ3426	RWZ3428	RWZ3426	
	└ DISPLAY assy	RWZ3427	RWZ3427	RWZ3427	RWZ3427	
NSP	STEREO DOUBLE CASSETTE DECK (CT - P550WR)	RXF1030	RXF1030	RXF1030	RXF1030	
	└ MECHANISM UNIT	RYM1235	RYM1235	RYM1235	RYM1235	
NSP	COMPACT DISC PLAYER (PD - P550)	RXF1032	RXF1032	RXF1032	RXF1029	
NSP	└ SINGLE MECHA ASSY	RXA1672	RXA1672	RXA1672	RXA1672	
NSP	└ SERVO MECHANISM ASSY SL	AXA7017	AXA7017	AXA7017	AXA7017	
NSP	└ MECHANISM BOARD assy	PWX1192	PWX1192	PWX1192	PWX1192	
NSP	DECK. CD assy	RWM1789	RWM1789	RWM1789	RWM1789	
	└ TC. MAIN assy (For CT - P550WR)	RWZ3440	RWZ3440	RWZ3440	RWZ3440	
NSP	└ TC. FUNC assy (For CT - P550WR)	RWZ3441	RWZ3441	RWZ3441	RWZ3441	
	└ CD. MAIN assy (For PD - P550)	RWZ3442	RWZ3442	RWZ3442	RWZ3442	
NSP	└ CD. FUNC assy (For PD - P550)	RWZ3443	RWZ3443	RWZ3443	RWZ3443	

Notes)

*1: Although RWZ3415 and RWZ3421 are different in part number, they consist of the same component.

*2: For AXQ7014, refer to page 68.

■ CONTRAST OF PCB ASSEMBLIES

MAIN Assy

RWZ3412 and RWZ3418 have the same construction except for the following :

Mark	Symbol & Description	Part No.		Remarks
		RWZ3412	RWZ3418	
	C2907, C2958 C2908, C2909, C2955	Not used Not used	CCCSL101J50 CKCYF103Z50	

H. P Assy

RWZ3413 and RWZ3419 have the same construction except for the following :

Mark	Symbol & Description	Part No.		Remarks
		RWZ3413	RWZ3419	
	C2904, C2905	Not used	CCCSL101J50	

SFC Assy

RWZ3414 and RWZ3420 have the same construction except for the following :

Mark	Symbol & Description	Part No.		Remarks
		RWZ3414	RWZ3420	
	L2951 C2191, C2192 C2910, C2911	Not used Not used Not used	LAUR22J CKCYB561K50 CCCSL101J50	

AC. CONNECT Assy

RWZ3416 and RWZ3422 have the same construction except for the following :

Mark	Symbol & Description	Part No.		Remarks
		RWZ3416	RWZ3422	
	L2001	Not used	ATF - 151	

SP. OUT Assy

RWZ3417 and RWZ3423 have the same construction except for the following :

Mark	Symbol & Description	Part No.		Remarks
		RWZ3417	RWZ3423	
	L2201, L2202 L2203, L2204 C2901, C2902, C2951, C2952 R2215, R2216	ATH - 133 Not used Not used RD1/4PMFL100J	ATH - 059 ATH - 059 CQMA102J50 RD1/4PMFL101J	

PRE. AMP Assy

RWZ3426 and RWZ3428 have the same construction except for the following :

Mark	Symbol & Description	Part No.		Remarks
		RWZ3426	RWZ3428	
	C3101, C3102	CKCYB391K50	CKCYB102K50	
	C3103, C3104, C3953, C3954	Not used	CKCYB102K50	
	C3958, C3959	Not used	CKCYB102K50	
	C3115, C3116	CCCCH101J50	CKCYB102K50	
	C3803	Not used	CFTXA184J50	
	C3903, C3905	Not used	CKCYB391K50	
	C3904, C3906	Not used	CKPUYB391K50	

■ PARTS LIST FOR MEXK/EA TYPE

Mark	No.	Description	Parts No.	Mark	No.	Description	Parts No.
■ STEREO AMPLIFIER (A - P550)				MAIN ASSY			
DISPLAY ASSY				SEMICONDUCTORS			
SEMICONDUCTORS				△	IC2016, IC2202, IC2301	ICP - N10	
	IC2502 - IC2504	NJM4558M		△	IC2011	NJM78M05FA	
	IC2501	PDC023B		△	IC2201	STK401 - 060	
	Q2502	2SC2458			Q2302	2SA1048	
	Q2501	DTC124ES			Q2013	2SA1515	
	D2501, D2503, D2505 - D2507	1SS254			Q2213	2SA992	
	D2601 - D2605	1SS254		△	Q2011, Q2012	2B1237X	
	D2502	BR3371XJ30A			Q2017	2B560	
	D2508, D2509	MTZJ6.2B/C			Q2211, Q2212	2C1845	
					Q2301, Q2303 - Q2307	2C2458	
COILS AND FILTERS					Q2014	2C3377	
	L2501	LAU101J			Q2016	ITC124ES	
SWITCHES AND RELAYS					Q2015	ITC124ES	
	S2501 - S2509	RSG1033		△	D2015, D2019, D2302, D2304	1SS254	
					D2011	I3SBA20 (B)	
CAPACITORS					D2305 - D2308	MTZJ11B	
	C2503, C2504	CEAS010M50			D2020	MTZJ30B	
	C2507	CEAS470M10			D2016	MTZJ6.2B/C	
	C2505	CFTXA224J50			D2021	MTZJ7.5B/C	
	C2509	CKPUYB101K50		△	D2013, D2014, D2017, D2018	S688G	
	C2506	CKPUYB102K50		△	D2022, D2023, D2301	S688G	
	C2613, C2614	CKPUYB471K50		SWITCHES AND RELAYS			
	C2603, C2606	CKPUYF103Z25			RY2301, RY2302	ASR1035	
	C2953, C2954	CKPUYF103Z25		CAPACITORS			
	C2604, C2605	CKPUYF223Z25		△	C2020 (0.01μF/150V)	ACG1005	
	C2501, C2508, C2601, C2602, C2609	CKPUYF473Z50			C2017	GANP330M35	
	C2612, C2615	CKPUYF473Z50			C2209, C2210, C2302	AS100M50	
	C2610, C2611	CKPUYX152M16			C2205 - C2208	AS101M50	
	C2607, C2608	CKPUYX472M16			C2013	AS102M16	
RESISTORS					C2015, C2016	AS220M16	
	All Resistors	RD1/6PM□□□J			C2019	AS220M50	
OTHERS					C2301	AS221M16	
	CN2501 22P CONNECTOR	52044 - 2245			C2303	AS2R2M50	
	REMOTE RECEIVER UNIT	GP1U27X			C2018	AS330M50	
	V2501 FL INDICATOR TUBE	RAW1142					
	X2501 (6.00MHZ)	VSS1045					

Mark	No.	Description	Parts No.
	C2021		CEAS470M50
	C2014		CEAS471M16
	C2201, C2202		CEASR15M50
	C2215		CGCYX104M16
	C2203, C2204		CKCYB471K50
	C2025		CKCYF103Z50
	C2211-C2214		CKCYF473Z50
	C2011, C2012 (3300 μ F/50V)		RCH1129
RESISTORS			
	R2021		RD1/2PM272J
	R2013		RD1/4PM221J
	R2320		RD1/4PM243J
	R2211, R2212		RD1/4PM4R7J
△	R2209, R2210		RD1/4PMFL101J
	R2315, R2316, R2318, R2319		RS2LMF271J
	R2011, R2012		RS2LMFR22J
	Other Resistors		RD1/6PM□□□J
OTHERS			
	CN2012	CABLE HOLDER (5P) 22P CONNECTOR	51052-0500 52045-2245
	CN2014	CABLE HOLDER 20P PLUG	AKT1007 KM200IA20
	CN2201	SOCKET 4-P	KP250NA4
	CN2011	SOCKET (18P)	RKP1717
	KN2011	EARTH METAL FITTING	VNF1084
H. P ASSY			
RESISTORS			
	R2213, R2214		RS2LMF331J
OTHERS			
	CN2204	CABLE HOLDER (5P) JACK	51052-0500 AKN1004
SFC ASSY			
SEMICONDUCTORS			
	IC2131		NJM4558D-D
	IC2101		PM0006A
	Q2134, Q2135		2SA1015
	Q2136, Q2137		2SC1815
	Q2131, Q2132		2SC2458
	Q2133		DTA124ES
CAPACITORS			
	C2139, C2140		CCCSL220J50
	C2101, C2102, C2109-C2112		CEAS100M50
	C2118, C2119		CEAS100M50
	C2144		CEAS220M10
	C2137, C2138		CEAS2R2M50
	C2113-C2115, C2143		CGCYX104M16
	C2141, C2142		CKCYF473Z50
	C2120, C2121		CKPUYB471K50
	C2106, C2108		CQMA102J50
	C2103, C2104		CQMA103J50
	C2135, C2136		CQMA393J50
	C2117		CQMA562J50
	C2105, C2107		CQMA683J50
RESISTORS			
	VR2131 (100K-B \times 2)		RCX1054
	R2143		RD1/6PM151J
	Other Resistors		RD1/6PM□□□J

Mark	No.	Description	Parts No.
CONNECT ASSY			
SEMICONDUCTORS			
	△ IC2012		ICP-N50
	△ IC2013		ICP-N70
CAPACITORS			
	C2202, C2203		CKCYF103Z50
OTHERS			
	CABLE HOLDER		AKT1007
AC. CONNECT ASSY			
AC. CONNECT ASSY has no service part.			
SP. OUT ASSY			
COILS AND FILTERS			
	L2201, L2202 (1UH)		ATH-133
RESISTORS			
	△ All Resistors		RD1/4PM□□□J
OTHERS			
	JA2201	SPEAKER TERMINAL 4-P	RKE1004
FM/AM DIGITAL SYNTHESIZER TUNER (F-P550RDS)			
FM/AM TUNER MOD. (RDS)/HE			
SEMICONDUCTORS			
	IC6201		LA1836M
	IC6202		LM7001J
	Q6102		2SC2223
	Q6203		2SC2235
	Q6202		2SC2712
	Q6103, Q6214		2SC2714
	Q6201		2SK208
	Q6104		2SK302
	Q6101		3SK194
	Q6204		XDA124EK
	Q6217		XDC124EK
	D6101, D6102		1T33
COILS AND FILTERS			
	L6104		ATC1003
	L6101		ATC1020
	L6102		ATC1021
	T6101		ATE-063
	L6207		ATE1013
	F6203, F6204		ATF-119
	F6101		ATF-155
	F6202 (450KHZ)		ATF1155
	L6103		ATH1043
	L6202, L6203, L6208		LCTA2R2J3225
CAPACITORS			
	C6234, C6236, C6270 (1 μ F/16V)		ACG1051
	C6107		CCSCH010C50
	C6229		CCSCH821J50
	C6110		CCSQCH020C50
	C6101		CCSQCH050C50
	C6108, C6203, C6269		CCSQCH101J50
	C6111, C6116, C6208, C6221, C6222		CCSQCH150J50
	C6115		CCSQCH330J50
	C6114		CCSQRH080D50
	C6113		CCSQRH180J50

Mark	No.	Description	Parts No.	Mark	No.	Description	Parts No.
	C6105		CCSQTH150J50	△	Q3004		2SB1237X
	C6261		CEAS010M50		Q3005		2SB560
	C6224, C6246, C6262		CEAS100M50		Q3201		2SC2668
	C6216, C6217		CEAS330M16	△	Q3001, Q3002		2SD1858X
	C6231, C6233		CEAS3R3M50		Q3108		DTA114ES
	C6219		CEAS470M10		Q3104		DTA124ES
	C6243-C6245		CEAS470M16		Q3105, Q3107, Q3203		DTC124ES
	C6227		CEAS470M25		D3004, D3005, D3011		1SS254
	C6238		CEJA100M16		D3012		MTZJ30B
	C6249, C6250		CEJA4R7M35		D3013		MTZJ5.1B/C
	C6215		CFTXA103J50		D3007		MTZJ6.2B/C
	C6214		CFTXA224J50		D3006		MTZJ6.8B
	C6103, C6106, C6112, C6204		CKSQYB102K50	△	D3001-D3003, D3008-D3010		S5688G
	C6102, C6109, C6117, C6210, C6264		CKSQYB103K50	△	D3014-D3016		S5688G
	C6213		CKSQYB223K50				
	C6230		CKSQYB273K50				
	C6228		CKSQYB472K50				
	C6209, C6237, C6265, C6267		CKSQYB473K50				
	C6252		CKSQYB822K50				
	C6212, C6218		CKSQYF103Z50				
	C6220, C6226, C6239, C6242, C6255		CKSQYF223Z50				
	C6235		CKSQYF224Z25				
	C6225, C6241, C6266		CKSQYF473Z50				
	C6232		CKSYB273K50				
	C6251		CKSYB822K50				
	C6223		CKSYF103Z50				
	C6263		CKSYF473Z50				
RESISTORS				CAPACITORS			
	VR6201 (10k)		ACP1056		C3016, C3115, C3116, C3952		CCCCH101J50
	VR6202		VRTB6VS223		C3960, C3961		CCCCH101J50
	R6299, R6300		RD1/8PM102J		C3204		CCCCH271J50
	R6113, R6116, R6118, R6268-R6271		RS1/8S000J		C3956		CCPUSL470J50
	R6275, R6276, R6278, R6283, R6284		RS1/8S000J		C3013, C3208, C3210		CEAS100M50
	R6290, R6293, R6294, R6297		RS1/8S000J		C3007, C3008		CEAS101M35
	R6243, R6244		RS1/8S101J		C3003		CEAS102M16
	R6211		RS1/8S103J		C3011, C3202		CEAS220M50
	R6237		RS1/8S182J		C3001		CEAS222M35
	R6209		RS1/8S221J		C3105, C3106, C3113, C3114		CEAS2R2M50
	R6239		RS1/8S332J		C3009, C3010		CEAS330M50
	R6101		RS1/8S470J		C3002, C3006, C3015, C3111, C3112		CEAS470M16
	Other Resistors		RS1/10S□□□□		C3005, C3014		CEAS471M10
					C3004		CEAS471M16
					C3201, C3209, C3211		CEAS4R7M50
					C3804, C3805		CGCYX473M25
					C3950		CKCYB102K50
					C3205		CKCYB103K50
					C3107, C3108		CKCYB152K50
					C3203, C3206		CKCYB332K50
					C3101, C3102		CKCYB391K50
					C3109, C3110		CKCYB562K50
					C3215		CKCYB682K50
					C3951, C3955		CKCYF103Z50
					C3212		CKCYF223Z50
					C3207		CKCYX103M16
					C3213, C3214		CKCYX333M16
OTHERS				RESISTORS			
	BN6201	TERMINAL 2-P WITH PAL	AKA1017		VR3201 (4.7K)		RCP1020
	X6203	CRYSTAL RESONATOR	ASS1042		R3013		RD1/2VM272J
	X6201	CRYSTAL RESONATOR	ASS1066		R3001, R3004		RD1/2VM821J
	X6202	CERAMIC RESONATOR	ATF1027		R3007, R3008		RD1/2VM8R2J
		AM RF TUNING BLOCK	AXX1041		R3132		RD1/4VM222J
					R3012		RD1/4VM472J
					Other Resistors		RD1/6PM□□□□
PRE. AMP ASSY SEMICONDUCTORS				OTHERS			
	IC3102		BU4052BC		CN3103	CONNECTOR (14P)	9176B-14L
	IC3103		BU4066BC		CN3104	PIN JACK (4P) (PHONO/AUX)	AKB1124
△	IC3003		ICP-N10			HEAT SINK	ANH-575
△	IC3002		ICP-N15		X3201 (456KHZ)		ASS7001
	IC3201		LA2232		CN3002	CONNECTOR (15P)	KPE15
	IC3101, IC3104		NJM4558D-D		CN3001	SOCKET (18P)	RKP1717
△	IC3001		NJM7812FA		KN3001	EARTH METAL FITTING	VNF1084
△	IC3007		NJM78L05A				
	Q3202		2SA1048				
	Q3106		2SA1515				

Mark	No.	Description	Parts No.
DISPLAY ASSY			
SEMICONDUCTORS			
	IC3301		PD4563B
	Q3301		DTC124ES
	D3301-D3304, D3306, D3308		1SS254
	D3307		MTZJ5.1B/C
	D3305		MTZJ7.5B/C
COILS AND FILTERS			
	L3301		LAU2R2J
SWITCHES AND RELAYS			
	S3301-S3309		RSG1033
CAPACITORS			
	C3302		ACH1246
	C3305, C3307		CEAS010M50
	C3301		CEJA470M16
	C3309-C3311		CKPUYB101K50
	C3304		CKPUYF103Z25
	C3306		CKPUYF223Z25
	C3303, C3308		CKPUYF473Z50
RESISTORS			
	All Resistors		RD1/6PM□□□J
OTHERS			
	V3301	FL INDICATOR TUBE	RAW1141
	X3301	(4.19MHZ)	VSS1014

STEREO DOUBLE CASSETTE DECK (CT-P550WR)

TC. MAIN ASSY

Mark	No.	Description	Parts No.
SEMICONDUCTORS			
	IC1101		BU4066BCF
	IC1201		CXA1101P
△	IC1011, IC1012		ICP-N10
	IC1202, IC1401		NJM4558D-D
	IC1102, IC1301		NJM4558M
△	IC1004		NJM7812FA
	IC1701		PD6153A
	Q1008		2SA1048
△	Q1006, Q1007		2SB1237X
△	Q1503		2SB1238X
	Q1854		2SB1425
	Q1009, Q1101, Q1102, Q1252-Q1255		2SC2458
	Q1301, Q1302, Q1772		2SC2458
	Q1501, Q1502, Q1504		2SD1302
△	Q1003-Q1005, Q1807, Q1857		2SD1858X
	Q1303, Q1304, Q1351, Q1352		2SD2144S
	Q1481, Q1482		2SD2144S
	Q1151, Q1152		2SK373
	Q1305, Q1483, Q1761-Q1764		DTA124EK
	Q1751-Q1754		DTA124ES
	Q1181-Q1184, Q1505, Q1765, Q1855		DTC124EK
	Q1755		DTC124ES
	Q1771		DTC124TS
	D1151-D1156, D1181, D1182		1SS254
	D1251, D1252, D1401, D1402		1SS254
	D1761, D1762, D1802, D1803, D1807		1SS254
	D1852-D1854, D1856, D1857		1SS254
	D1012		MTZJ3.6B
	D1006, D1009		MTZJ6.8B
△	D1001-D1003, D1010, D1011		S5688G
△	D1013-D1015, D1801, D1851		S5688G

Mark	No.	Description	Parts No.
COILS AND FILTERS			
	L1951		LAU010J
	L1303, L1304	[3.3MH (252KHZ)]	RTF1019
	L1181, L1182		RTF1099
	L1301, L1302		RTF1102
	F1201, F1202		RTF1208
TRANSFORMERS			
	T1501		ATX-043
CAPACITORS			
	C1509, C1510		CCCSL101K500
	C1301, C1302		CCCSL221K500
	C1151, C1152		CCSQCH100D50
	C1953, C1954		CCSQCH101J50
	C1401, C1403		CCSQCH560J50
	C1253, C1254		CCSLSL151J50
	C1303, C1304		CCSLSL681J50
	C1103, C1104		CEANL100M16
	C1183, C1184, C1217, C1218		CEAS010M50
	C1283, C1284, C1317, C1318		CEAS010M50
	C1009, C1019		CEAS100M16
	C1219, C1252, C1402, C1507		CEAS100M50
	C1211		CEAS101M10
	C1005		CEAS102M16
	C1010		CEAS102M6R3
	C1771		CEAS220M50
	C1006, C1007		CEAS221M10
	C1014		CEAS221M16
	C1004		CEAS222M35
	C1305, C1306		CEAS2R2M50
	C1105, C1106, C1311, C1312		CEAS330M16
	C1319, C1320, C1505, C1506		CEAS330M16
	C1109, C1110, C1281, C1282, C1701		CEAS470M16
	C1011		CEAS471M16
	C1203, C1204, C1215, C1216		CEAS4R7M50
	C1251		CEASR33M50
	C1213, C1214		CEASR68M50
	C1209, C1210, C1503, C1504		CFTXA103J50
	C1501		CFTXA123J50
	C1502		CFTXA152J50
	C1113, C1114		CFTXA681J50
	C1107, C1108		CFTXA682J50
	C1307, C1308		CFTXA823J50
	C1601-C1604		CKCYB561K50
	C1001, C1002, C1020, C1021		CKCYF473Z50
	C1951, C1952, C1955-C1958		CKSQYB101K50
	C1703, C1772		CKSQYB101K50
	C1404		CKSQYB101K25
	C1309, C1310		CKSQYB181K50
	C1313-C1316		CKSQYB331K25
	C1181, C1182		CKSQYB391K50
	C1101, C1102		CKSQYB561K50
	C1111, C1153, C1154, C1802, C1852		CKSQYB681K50
	C1702		CKSQYF47Z50
	C1212		CQMA104J0
	C1511		CQPA162J10
RESISTORS			
	VR1181-VR1184, VR1301, VR1302 (22K)		RCP1046
	VR1501, VR1502 (220K)		RCP1049
	VR1851 (3.3K)		RCP1089
	R1203, R1204 (22K, W=1/6)		RCN1023
△	R1501		RD1/2LMF10J

Mark	No.	Description	Parts No.
	R1505		RD1/2VM121J
	R1504		RD1/2VM4R7J
	R1506		RD1/2VM680J
	R1014, R1015		RD1/2VM821J
	R1121		RD1/6PM103J
	R1119, R1120, R1212, R1321, R1322		RD1/6PM820J
	Other Resistors		RS1/10S□□□J

OTHERS

CN1701	13P JUMPER CONNECTOR CABLE HOLDER	52147-1310 AKT1023
CN1103	2P TOP POST	B2B-EH
CN1102	3P TOP POST	B3B-EH
CN1101	3P TOP POST	B3B-EH-R
CN1001	SOCKET (18P) PCB BINDER	RKP1717 VEF1008
KN1001	EARTH METAL FITTING	VNF1084
X1701	(4.19MHZ)	ASS1022

TC. FUNC ASSY

SEMICONDUCTORS

D1901, D1902, D1951	1SS254
D1903, D1905, D1906	SLR-342MCT31
D1907	SLR-342VRT31
D1904	SLR-342YCT31

SWITCHES AND RELAYS

S1901-S1907, S1951, S1952	RSG1033
---------------------------	---------

RESISTORS

All Resistors	RD1/6PM□□□J
---------------	-------------

COMPACT DISC PLAYER (PD-P550)

MECHANISM BOARD ASSY

SWITCHES AND RELAYS

S610	DSG1016
------	---------

OTHERS

CN610	MT CONNECTOR 4P	173979-4
-------	-----------------	----------

CD. MAIN ASSY

SEMICONDUCTORS

IC151	CXA1372Q
IC301	CXD2508AQ
△ IC22	ICP-N10
△ IC201	LA6517
△ IC202	LA6520
IC401	NJM4558D-D
△ IC11	NJM78M05FA
IC351	PD4564A
Q433, Q434	2SD2144S
Q301	2SK246
Q352, Q431, Q432	DTA124EK
Q351	DTC124EK
D301, D302	1SS254
D201	MTZJ6.8B
△ D11-D14	S5688G

COILS AND FILTERS

L301	LAU1R2J
L951	LAU2R2J

Mark	No.	Description	Parts No.
------	-----	-------------	-----------

CAPACITORS

C310	CCSQCH100D50
C165	CCSQCH102J50
C403, C404, C409, C410	CCSQCH121J50
C312	CCSQCH220J50
C405-C408	CCSQCH271J50

C401, C402	CCSQCH391J50
C411, C412	CEALNP2R2M35
C20-C22	CEAS222M16
C351	CEAS330M16
C23	CEAS471M6R3

C156, C158, C354	CEAS4R7M50
C309	CEASR47M50
C11	CKCYF103Z50
C951	CKSQYB102K50
C153, C160, C161, C163, C201	CKSQYB103K50

C308	CKSQYB103K50
C154, C155, C157, C159	CKSQYB104K25
C211, C212	CKSQYB104K25
C306, C413, C414	CKSQYB152K50
C164	CKSQYB332K50

C152, C162	CKSQYB333K25
C166	CKSQYB472K50
C307	CKSQYB473K25
C151	CKSQYB561K50
C311	CKSQYF102Z50

C14, C241-C244, C353, C355	CKSQYF103Z50
C421, C422	CKSQYF104Z25
C313	CKSQYF473Z50
C304	CKSQYF105Z16

RESISTORS

VR151, VR152 (22K)	RCP1046
Other Resistors	RS1/10S□□□J

OTHERS

CN151	CONNECTOR	12FMZ-ABT
CN201	MT CONNECTOR (4P)	173981-4
CN202	MT CONNECTOR (5P)	173981-5
CN351	8P JUMPER CONNECTOR	52147-0810
CN11	SOCKET (15P)	AKP1090

X301 (33.8688MHZ±700PPM)	ASS7000	
CN301	TOP POST (6P) PCB BINDER	B6P-SHF-1AA
KN310	EARTH METAL FITTING	VEF1008
X351 (4.19MHZ)	VNF1084	
	VSS1014	

CD. FUNC ASSY

SEMICONDUCTORS

D501-D503	1SS254
D504	AE11055

SWITCHES AND RELAYS

S501-S507	RSG1033
-----------	---------

RESISTORS

All Resistors	RS1/10S□□□J
---------------	-------------

● Parts List for MEZIXK/DI Type

Mark	No.	Description	Parts No.
FM/AM TUNER MOD. (RDS)/HEZ (AXQ7014)			
SEMICONDUCTORS			
	IC6201		LA1836M
	IC6202		LM7001J
	Q6102		2SC2223
	Q6203		2SC2235
	Q6202, Q6218		2SC2712
	Q6103, Q6214		2SC2714
	Q6201		2SK208
	Q6104, Q6105		2SK302
	Q6101		3SK194
	Q6204		XDA124EK
	Q6217		XDC124EK
	D6101-D6104		1SV228
COILS AND FILTERS			
	L6106		ATC1003
	L6105		ATC1015
	L6101		ATC1016
	L6102		ATC1017
	L6103		ATC1018
	L6104		ATC1019
	L6207 (10.7MHZ)		ATE1013
	F6204		ATF-107
	F6203		ATF-119
	F6205		ATF1152
	F6202 (450KHZ)		ATF1155
	L6107 (2.2μH)		ATH1043
	L6202, L6203, L6208		LCTA2R2J3225
	L6205		LCTA680J3225
CAPACITORS			
	C6204, C6234, C6236, C6269 (105/16)		ACG1051
	C6120		CCSCH060D50
	C6229		CCSCH102J50
	C6111, C6122		CCSQCH010C50
	C6112		CCSQCH020C50
	C6118		CCSQCH080D50
	C6113		CCSQCH101J50
	C6116, C6208, C6221, C6222		CCSQCH150J50
	C6117		CCSQCH330J50
	C6272		CCSLSL330J50
	C6105		CCSLSL471J50
	C6101		CCSQTH110J50
	C6119		CCSQTH150J50
	C6109		CCSQTH270J50
	C6107, C6110		CCSQTH300J50
	C6106		CCSQTH330J50
	C6261		CEAS010M50
	C6224, C6231, C6233, C6246, C6262		CEAS100M50
	C6216, C6217		CEAS330M16
	C6219		CEAS470M10
	C6243-C6245		CEAS470M16
	C6227		CEAS470M25
	C6238, C6248		CEJA100M16
	C6249, C6250		CEJA4R7M35
	C6215		CFTXA103J50
	C6214		CFTXA224J50
	C6115, C6125, C6126, C6207		CKSQYB102K50
	C6102, C6114, C6121, C6124, C6210		CKSQYB103K50
	C6264		CKSQYB103K50
	C6247		CKSQYB122K50

Mark	No.	Description	Parts No.
	C6213		CKSQYB223K50
	C6230		CKSQYB273K50
	C6228		CKSQYB472K50
	C6209, C6237, C6267		CKSQYB473K50
	C6251, C6252		CKSQYB562K50
	C6212, C6218		CKSQYF103Z50
	C6220, C6226, C6239, C6242		CKSQYF223Z50
	C6255, C6256		CKSQYF223Z50
	C6235		CKSQYF224Z25
	C6225, C6241		CKSQYF473Z50
	C6123		CKSYB103K50
	C6232		CKSYB273K50
	C6223		CKSYF103Z50
	C6263		CKSYF473Z50
RESISTORS			
	VR6201 (10K)		ACP1056
	VR6202		VRTB6VS223
	R6299, R6300		RD1/6PM102J
	R6115, R6119, R6123, R6127, R6129		RS1/8S000J
	R6268-R6271, R6275, R6276, R6278		RS1/8S000J
	R6283, R6284, R6293, R6294, R6297		RS1/8S000J
	R6302, R6303		RS1/8S000J
	R6243, R6244		RS1/8S101J
	R6211, R6239		RS1/8S103J
	R6237		RS1/8S122J
	R6209		RS1/8S221J
	R6112		RS1/8S473J
	Other Resistors		RS1/10S□□□□
OTHERS			
	BN6201	2P ANTENNA TERMINAL WITH PAL	AKA1017
	X6203 (7.200MHZ)		ASS1042
	X6201 (456KHZ)		ASS1066
	X6202 (450KHZ)		ATF1027

6. SINGLE OPERATION METHOD

- As this product is a system product, operation with assembled components.
- When single operation can not be avoided, supply power etc. according to the following method.
The Stereo amplifier (A-P550) operates by itself.

1. FM/AM DIGITAL SYNTHESIZER TUNER (F-P550RDS)

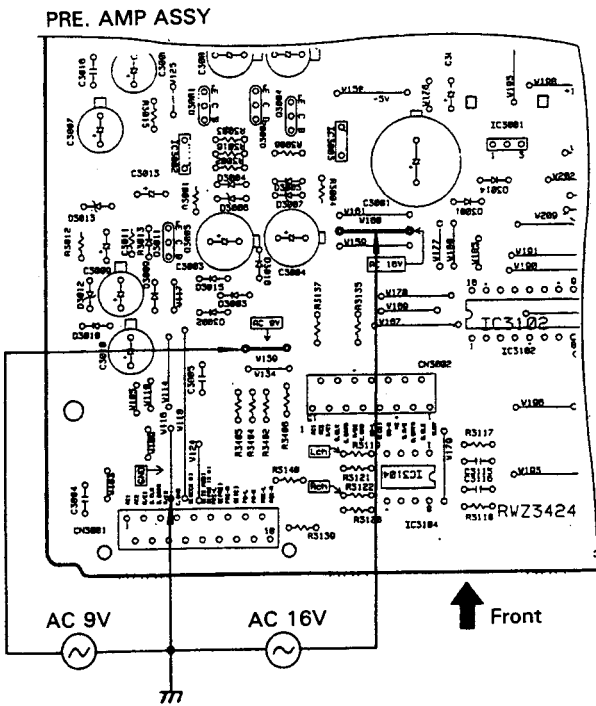

Provide the above potentials to the jumper wires of the figure.

2. COMPACT DISC PLAYER (PD-P550)

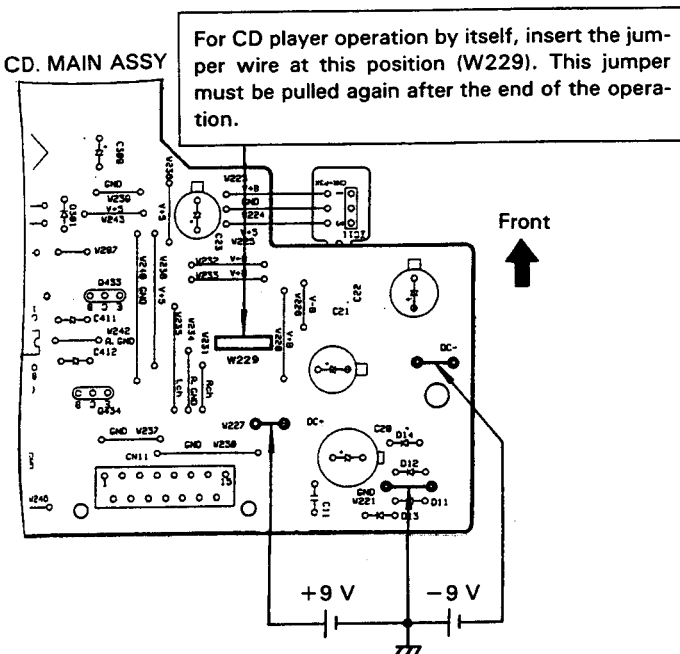

Provide the above potentials to the jumper wires of the figure.

3. STEREO DOUBLE CASSETTE DECK (CT-P550WR)

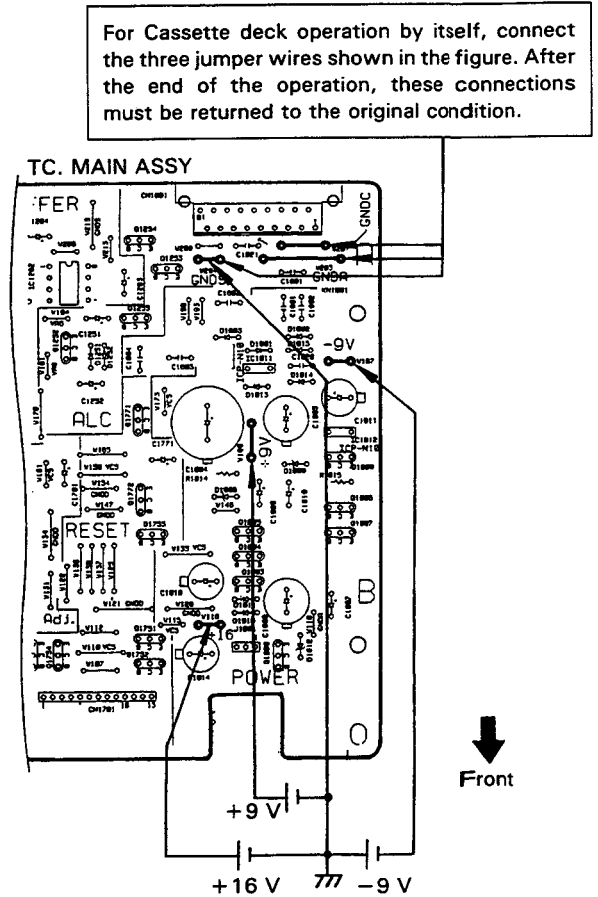

Provide the above potentials to the jumper wires of the figure.

7. ADJUSTMENTS

7.1 FM/AM DIGITAL SYNTHESIZER TUNER SECTION (F – P550RDS)

■ FM Tuner Section

- Set the FM/AM selector to FM BAND.
- Connect the wiring as shown in Fig. 1-1.

- For MEXK/EA, MEXK/EB and NBXK types (AXQ7013)

Step No.	Adjustment Title	FM SG (1kHz, ±75kHz dev.)		Reception Frequency Display	Adjustment Location	Specifications
		Frequency (MHz)	Level (dBμV)			
1	Center Adjustment	98 Non Modulation	80 or more	98.0 MHz	L6207	Adjust so that the DC voltage between IC6201-Pin 4 and Pin 28 (or ⊕ leads of C6224 and C6261) becomes 0V ±50mV.
2	Front-end Sensitivity Adjustment	98	Low input (0 to 30)	98 MHz	L6102 T6101	Adjust so that the DC voltage between IC6201-Pin 12 and GND (or ⊕ leads of C6238 and GND) becomes at maximum level.
3	Stereo Distortion	98	80	98 MHz	T6101	Minimize the distortion with 1/8 rotation of the core.
4	TUNED IND. Lighting Level	98	15 (±2 dB)	98.0 MHz	VR6201	Adjust so that the indicator of TUNED IND. starts to light up.

Notes:

- Before adjusting, make sure there is no gap between L6101 and L6102. If there is a gap between them, bring them into contact with each other first, and then make adjustments.
- Make indicator adjustments in order of AM → FM.
- Adjustment sequence: L6102 T6101

- For MEZIXK/DI type (AXQ7014)

Step No.	Adjustment Title	FM SG (1kHz, ±75kHz dev.)		Reception Frequency Display	Adjustment Location	Specifications
		Frequency (MHz)	Level (dBμV)			
1	Center Adjustment	98	80	98 MHz	L6207	Adjust so that the DC voltage between IC6201-Pin 4 and Pin 28 (or ⊕ leads of C6224 and C6261) becomes 0V ±50mV.
2	Front End Sensitivity Adjustment	106	Low input (0 to 30)	106MHz	L6104 L6105 L6102 T6101	After adjusting L6104 and L6105 so that the DC voltage between IC6201-Pin 12 and GND (or ⊕ leads of C6238 and GND) becomes at maximum level, adjust T6101 and L6102.
3	Stereo Distortion	98	80	98 MHz	T6101	Minimize the distortion with 1/8 rotation of the core.
4	TUNED IND. Lighting Level	98	15 (±2 dB)	98MHz	VR6201	Adjust so that the indicator of TUNED IND. starts to light up.

Notes:

- Before adjusting, make sure there is no gap between L6101 and L6102 and between L6103 and L6104. If there is a gap between them, bring them into contact with each other first, and then make adjustments.
- Make indicator adjustments in order of AM → FM.
- Adjustment sequence : L6104 → L6105 → L6102 → T6101

AM Tuner Section

- Set the FM/AM selector to AM BAND.
- Connect the wiring as shown in Fig. 1-1.

Step No.	Adjustment Title	AM SG (400Hz, 30% Mod.)		Reception Frequency Display	Adjustment Location	Specifications
		Frequency (kHz)	Level (dB μ V/m)			
1	TUNED IND. Lighting Level	999*1	47 (± 2 dB)	999 kHz*1	VR6202	Adjust so that the indicator of TUNED IND. starts to light up.

*1: For the area using 10 kHz step, frequencies should be 1000 kHz.

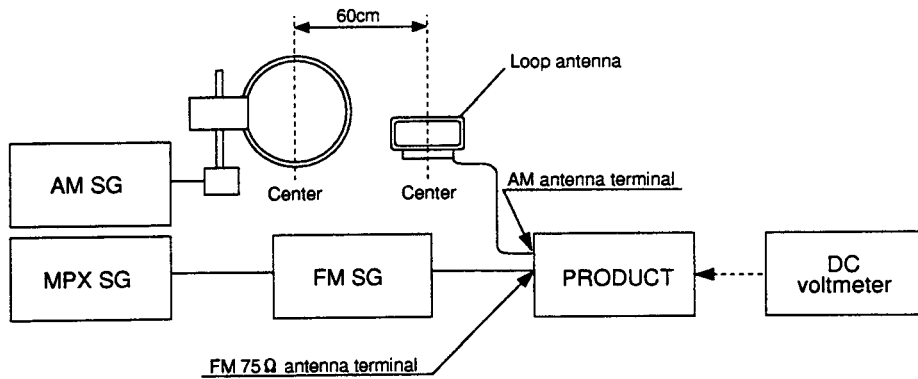
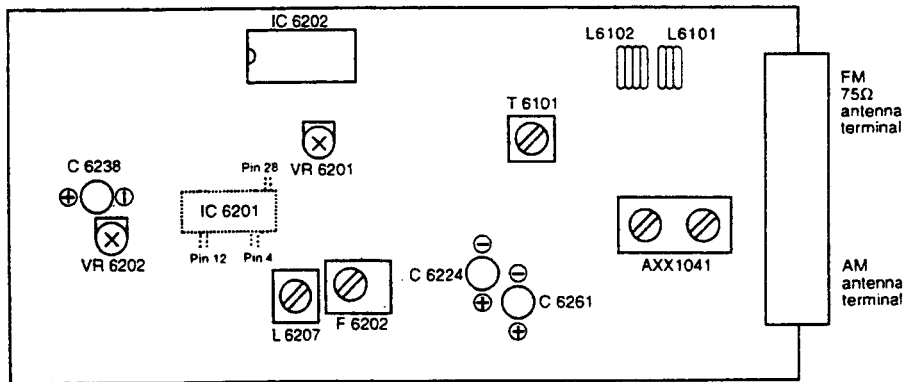

Fig. 1-1 AM and FM Adjustment Wiring Diagram

FM/AM TUNER MOD. (RDS)/HE (AXQ7013)



FM/AM TUNER MOD. (RDS)/HEZ (AXQ7014)

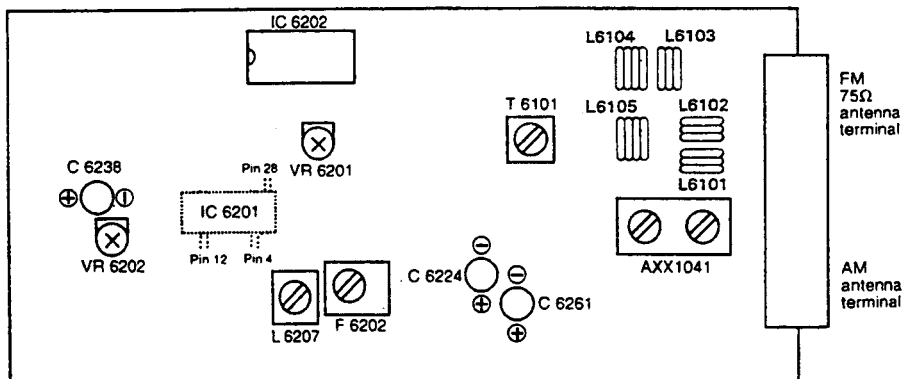

Fig. 1-2 Adjustment Points

RDS Adjustment

- Setting the RDS-Signal generator (*1).
- Set the mode selector to FM BAND.
- Connect the wiring as shown in Fig. 1-3

*Note *1 : Audio Main 1kHz, 85 %
Pilot 10 % RDS 1.6 %
SK 4.7 %*

Step No.	Adjustment Title	FM/AM SG		Reception Frequency Display	Adjustment Location	Specifications
		Frequency (MHz)	Level (dB μ V)			
1	RDS (BPF) Level	88	60	88MHz	VR3201	Adjust so that the Waveform of TP3201 (RDS) becomes at maximum. (Photo 1)
2	RDS IND. Lighting Level Verification	88	60	88MHz	—	Confirm that the RDS IND. to light up.

Note: Entry into RDS mode is done by switching to the FM band and entering an RDS signal from FM (RDS) SG to the FM 75 Ω antenna terminal.

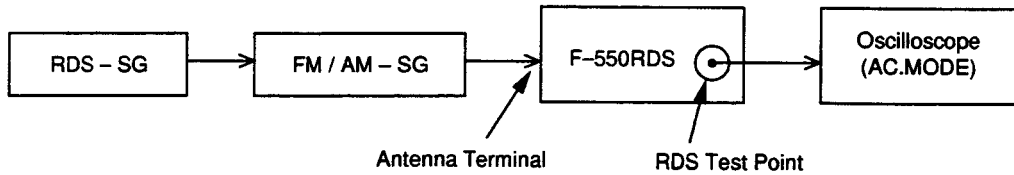

Fig. 1-3 RDS Adjustment Wiring Diagram

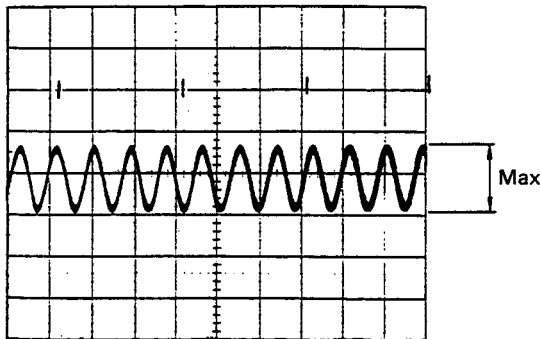

Photo 1

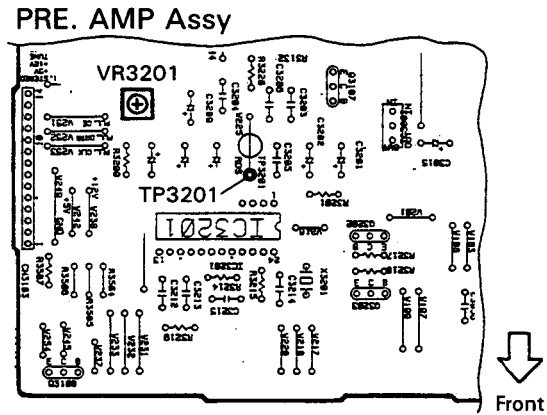

Fig. 1-4 Adjustment Points

7.2 STEREO DOUBLE CASSETTE DECK SECTION (CT-P550WR)

● Adjustment points and test points are shown in Fig. 2-3 and Fig. 2-4.

1. Test Mode

(1). Test mode outline

The test modes are the test mode 1 for execution of special operations and the test mode 2 with MUTE operation in the same way as for a single cassette deck.

(2). Test mode 1

■ Entry into test mode 1

Switch on the power supply while short-circuit the jumper wires JP1 and JP2 in the TC. MAIN assy (refer to Fig. 2-4), and afterwards disconnect the jumper wires.

■ Operation in test mode 1

- The REC LED flashes during test mode 1.
- Flashing of the I/II KEY SEL indication shows the operating mechanism.
- LINE MUTE opens in the same way as for the single cassette deck also during REC and REC PAUSE.
- The mechanism can operate independent of the presence or absence of tape.
- When the tape type detection switch for the mechanism on the side where the I/II KEY SEL indication does not flash is set to ON, the I/II KEY SEL for that side will light.

■ Cancellation method for test mode 1

When the ASES/COPY key is pressed twice with both mechanisms in STOP condition, test mode 1 is cancelled and normal operation will be executed. However, when this key is pressed once, the mode shifts from test mode 1 to test mode 2.

2. Mechanical Adjustment

- Please execute this adjustment in test mode 1.
- Test tape: STD-301 (3kHz, 30min).
- The ground at the time of adjustment shall be W204 (refer to Fig. 2-4).

■ Tape Speed Adjustment

No.	Mode	Test Tape	Adjusting Points	Measurement Points	Adjustment Procedure	Remarks
1	PLAY	STD-301 (Playback: 3kHz)	TC. MAIN Assy VR1851	CN1001-Pin15 (L) or Pin16 (R) (TC. MAIN Assy)	Set the test tape to mechanism unit II, press the PLAY SW and adjust so that the reading becomes 3000Hz ± 5Hz.	

(3). Test mode 2

■ Entry into test mode 2

Press the ASES/COPY key once in the test mode 1 with both mechanisms in STOP condition.

■ Operation in test mode 2

- The REC LED flashes. (The flashing is more rapid than in test mode 1.)
- In REC and REC PAUSE condition, LINE MUTE opens in the same way as for the single cassette deck. Otherwise, normal operation and indication are executed.

■ Cancellation method for test mode 2

Press the ASES/COPY key or switch off the power supply.

3. Electrical Adjustment

- Please execute this adjustment in test mode 2.
- The ground at the time of adjustment shall be W204 (refer to Fig. 2-4).

Check the following before starting.

1. Confirm that the tape speed adjustment has been completed.
2. Clean the heads and demagnetize them using a head eraser.
3. Set the measurement level to 0 dBV = 1 Vrms.
4. When A-P550 and F-P550 are not connected to CN1001, connect load resistors of 22kΩ each (21kΩ to 23kΩ) to pin 15 and pin 16.
5. Use the specified tape for adjustment. Use the labeled (A) side of the test tape.
STD-331E: For playback adjustment
STD-631: Normal blank tape
6. Provide yourself with the following measuring devices:
 - AC millivoltmeter
 - Low-frequency oscillator
 - Attenuator
 - Oscilloscope
7. Adjust both right and left channels unless otherwise specified.
8. Turn the DOLBY NR switch off unless otherwise specified.
9. Warm up the unit for several minutes before adjustment. In particular, be sure to warm up the unit in the REC/PLAY mode for 3 to 5 minutes before starting recording/playback frequency characteristics adjustment.
10. Always follow the indicated adjustment order. Otherwise, a complete adjustment may not be achieved.

Playback Adjustment (Decks I and II)

1. Head Azimuth Adjustment
2. Playback Level Adjustment

Recording Adjustment (Deck II)

1. Recording Bias Adjustment
2. Recording Level Adjustment.

*As the reference recording level is 250nwb/m for STD-331E, the recording level will be higher by 4 dB for STD-331B (160nwb/m). When adjusting, pay careful attention to the type of tape used.

Dolby noise reduction manufactured under license from Dolby Laboratories Licensing Corporation. "DOLBY" and the double-D symbol  are trademarks of Dolby Laboratories Licensing Corporation.

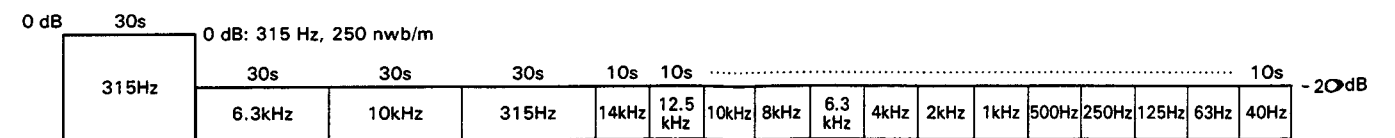

Fig. 2-1 STD-331E Test Tape

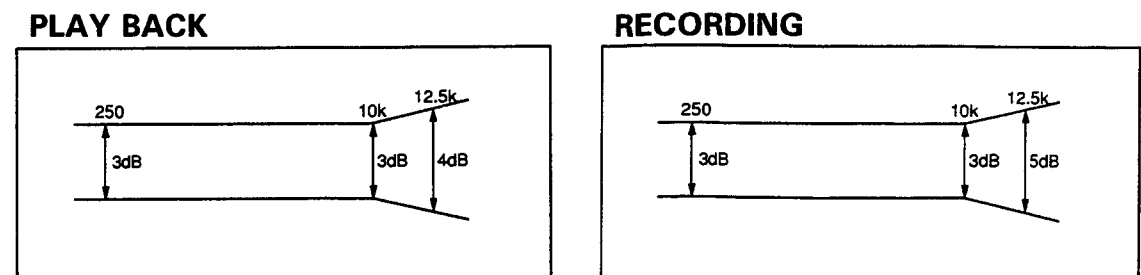

Fig. 2-2 Frequency Characteristics

■ Before Adjustment

Removal of the azimuth covers (L), (R)

1. Open the door panels (L) and (R).
2. Press the section ① (recessed part) on the inside of the door panels (L) and (R) with a flat screwdriver as shown in the figure.
3. Confirm that the azimuth covers (L) and (R) have come a little to the front, and then close the door panels (L) and (R).
4. Insert a flat screwdriver at the lower side of the azimuth covers (L) and (R) and pull them to the front.

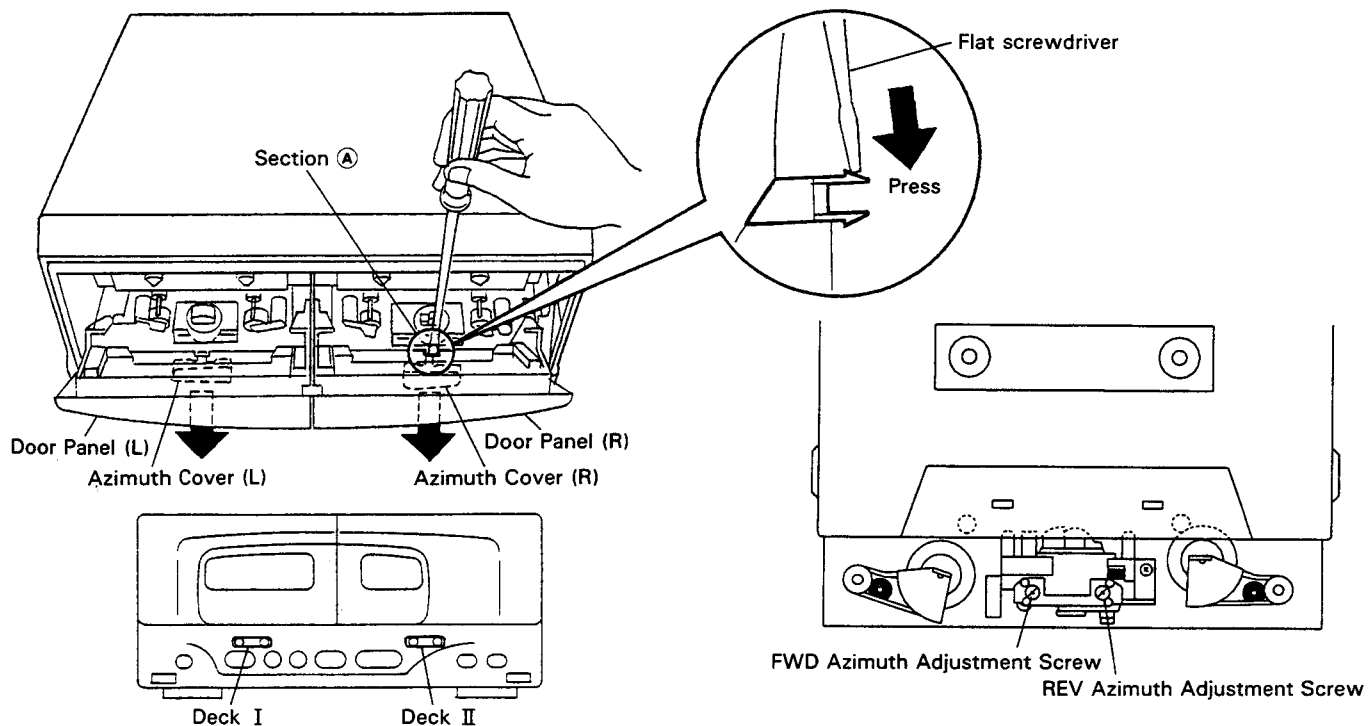

Fig. 2-3 Head Azimuth Adjustment

● Playback Adjustment

1. Head Azimuth Adjustment

- This unit is equipped with auto tape selector.
- Do not switch between forward and reverse operation with the screwdriver inserted.

Step	Tape Selector (AUTO)	Mode	Input Signal/ Test Tape	Adjusting Points	Measurement Points	Adjustment Value	Remarks
1	NORMAL	PLAY	STD-331E test tape (Playback: 10kHz, -20dB)	Deck I Deck II	Head azimuth adjustment screw (Fig. 2-3)	CN1001 Pin15 (L) or Pin16 (R) (TC. MAIN Assy)	Max. playback signal level After adjustment, apply silicon bond to the head azimuth adjustment screw.

2. Playback Level Adjustment

- Since this adjustment determines playback Dolby NR level, perform it carefully.

Step	Tape Selector (AUTO)	Mode	Input Signal/ Test Tape	Adjusting Points	Measurement Points	Adjustment Value	Remarks
1	NORMAL	PLAY	STD-331E test tape (Playback: 315Hz, 0dB)	Deck I Deck II	VR1181 (Lch) VR1182 (Rch) VR1183 (Lch) VR1184 (Rch)	TP1 (Lch) TP2 (Rch) (TC. MAIN Assy)	-11.2 dBV

● Recording Adjustment

1. Recording Bias Adjustment

- After the adjustment, caution should be exercised so as not to become under bias by checking the distortion rate.

Step	Tape Selector (AUTO)	Mode	Input Signal/ Test Tape	Adjusting Points	Measurement Points	Adjustment Value	Remarks
1	NORMAL	REC/ PAUSE	Input a 315Hz signal to the VIDEO/AUX terminal and set the input selector to VIDEO.	Input Signal Level	CN1001 Pin15 (L) and Pin16 (R) (TC. MAIN Assy)	-26.0 dBV	Repeat adjustment until playback level of the 10kHz signal is within 0±0.5dB from that of the 315Hz signal.
2	NORMAL	REC → PLAY	Load the STD-631 test tape and record/playback the 315Hz and 10kHz signals. (see the Ncte below)	Deck I Deck II		VR1501 (Lch) VR1502 (Rch)	

Note: Set the 10 kHz input signal level to the same value as the 315 Hz input signal level of step 1.

2. Recording Level Adjustment

Step	Tape Selector (AUTO)	Mode	Input Signal/ Test Tape	Adjusting Points	Measurement Points	Adjustment Value	Remarks
1	NORMAL	REC/ PAUSE	Input a 315Hz signal to the VIDEO/AUX terminal and set the input selector to VIDEO.	Input Signal Level	TP1 (Lch) TP2 (Rch) (TC. MAIN Assy)	-11.2 dBV	Repeat recording, playback and adjustment until playback level of the 315Hz signal becomes -11.2dBV.
2	NORMAL	REC → PLAY	STD-631 test tape and record/playback the 315Hz signal.	Deck I Deck II		VR1301 (Lch) VR1302 (Rch)	

TC. MAIN Assy

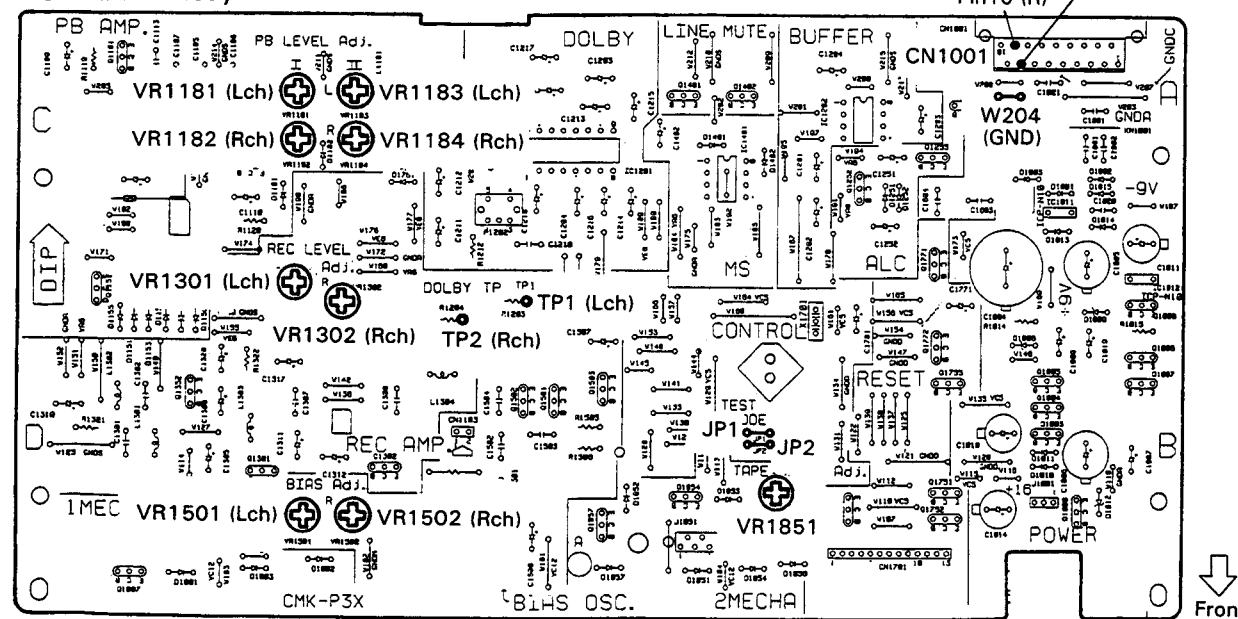

Fig. 2-4 Adjustment and Measurement Points

7.3 COMPACT DISC PLAYER SECTION (PD – P550)

■ Adjustment Methods

If a disc player is adjusted incorrectly or inadequately, it may malfunction or not work at all even though there is nothing at all wrong with the pickup or the circuitry. Adjust correctly following the adjustment procedure.

● Adjustment Items/Verification Items and Order

If the specified values cannot be obtained or no adjustment is possible by performing the verifications or adjustments described in steps 1–4, the pickup block may be defective.

Step	Item	Test Point	Adjustment Location
1	Focus offset verification	TP1, Pin6 (FCS. ERR)	None
2	Tracking error balance verification	TP1, Pin2 (TRK.ERR)	None
3	Pickup radial/tangential direction tilt adjustment	TP1, Pin1 (RF)	Radial tilt adjustment screw, Tangential tilt adjustment screw
4	RF level verification	TP1, Pin1 (RF)	None
5	Focus servo loop gain adjustment	TP1, Pin5 (FCS. IN) TP1, Pin6 (FCS. ERR)	VR152 (FCS. GAN)
6	Tracking servo loop gain adjustment	TP1, Pin3 (TRK. IN) TP1, Pin2 (TRK. ERR)	VR151 (TRK. GAN)

Abbreviation Table

FCS. ERR	: Focus Error
TRK. ERR	: Tracking Error
FCS. GAN	: Focus Gain
TRK. GAN	: Tracking Gain
FCS. IN	: Focus In
TRK. IN	: Tracking In

● Measuring Instruments and Tools

1. Dual trace oscilloscope (10 : 1 probe)
2. Low-frequency oscillator
3. Test disc (YEDS-7)
4. Low pass filter (39k Ω + 0.001 μ F)
5. Resistor (100k Ω)
6. 8 cm disc (With at least about 20 minutes of recording)
7. Ball point hexagon wrench (GGK1002)
8. Standard tools

● Test Point and Adjustment Variable Resistor Positions

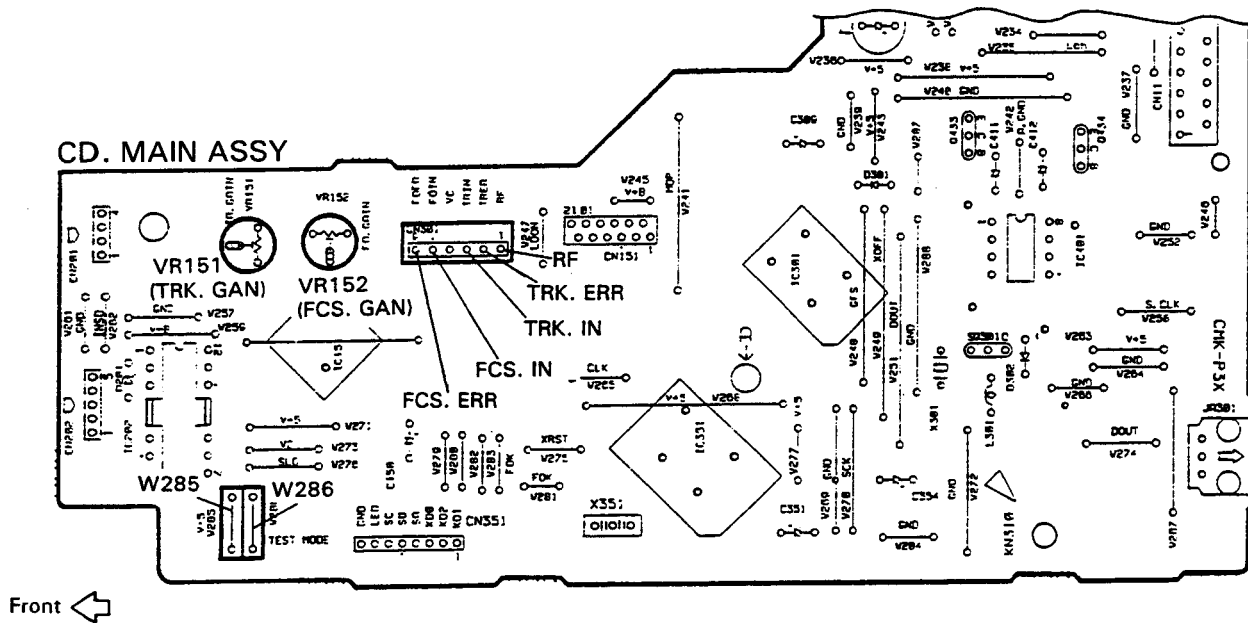

Fig. 3-1 Adjustment Location

● Notes

1. Use a 10 : 1 probe for the oscilloscope.
2. All the knob positions (settings) for the oscilloscope in the adjustment procedures are for when a 10 : 1 probe is used.
3. GND of the oscilloscope connect to TP1, pin4 (VC). If GND is shorted to the ground of the player, the player should be damaged.

● Test Mode

These models have a test mode so that the adjustment and checks required for service can be carried out easily. When these models are in test mode, the keys on the front panel work differently from normal. Adjustments and checks can be carried out by operating these keys with the correct procedure. For these models, all adjustments are carried out in test mode.

[Setting these models to test mode]

How to set this model into test mode.

1. Unplug the power cord from the AC socket.
2. Short-circuit jumper wires (W285 and W286) for the test mode (See Fig. 3-1).
3. Plug the power cord back into the AC socket.

When the test mode is set correctly, the display is different from what it usually is when the power is turned on. If the display is still the same as usual, test mode has not been set correctly, so repeat Steps 1-3.



[Release from test mode]

Here is the procedure for releasing the test mode:

1. Press the STOP key and stop all operations.
2. Turn off the power switch.

[Operations of the keys in test mode]

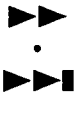
Code	Key Name	Function in Test Mode	Explanation
	PGM/EDIT	Focus servo close	<p>The laser diode is lit up and the focus actuator is lifted up, then lowered slowly and the focus servo is closed at the point where the objective lens is focused on the disc.</p> <p>With the player in this state, if you lightly rotate the stopped disc by hand, you can hear the sound the focus servo.</p> <p>If you can hear this sound, the focus servo is operating correctly. If you press this key with no disc mounted, the laser diode lights up, the focus actuator is pulled up, then the actuator is lowered and raised three times and returned to its original position.</p>
▶/	PLAY/PAUSE	Spindle servo ON	<p>Starts the spindle motor in the clockwise direction and when the disc rotation reaches the prescribed speed (about 500rpm at the inner periphery), sets the spindle servo in a closed loop.</p> <p>Be careful. Pressing this key when there is no disc mounted makes the spindle motor run at the maximum speed.</p> <p>If the focus servo does not go correctly into a closed loop or the laser light shines on the mirror section at the outermost periphery of the disc, the same symptom is occurred.</p>
		Tracking servo close/open	<p>Pressing this key when the focus servo and spindle servo are operating correctly in closed loops puts the tracking servo into a closed loop, displays the track number being played back and the elapsed time on the front panel, and outputs the playback signal.</p> <p>If the elapsed time is not displayed or not counted correctly or the audio is not played back correctly, it may be that the laser is shining on the section with no sound recorded at the outer edge of the disc, that something is out of adjustment, or that there is some other problem.</p> <p>This key is a toggle key and open/close the tracking servo alternately. This key has no effect if no disc is mounted.</p>

Code	Key Name	Function in Test Mode	Explanation
	MANUAL/ TRACK SEARCH REV	Carriage reverse (inwards)	Moves the pickup position toward the inner diameter of the disc. When this key is pressed with the tracking servo in a closed loop, the tracking servo automatically goes into an open loop. Since the motor does not automatically stop at the mechanical end point in test mode, be careful with this operation.
	MANUAL/ TRACK SEARCH FWD	Carriage forward (outwards)	Moves the pickup position toward the outer diameter of the disc. When this key is pressed with the tracking servo in a closed loop, the tracking servo automatically goes into an open loop. Since the motor does not automatically stop at the mechanical end point in test mode, be careful with this operation.
	STOP	Stop	Initializes and the disc rotation stops. The pickup and disc remain where they are when this key is pressed.
	EJECT	Disc Load in/Load out	Load in/Load out the disc. This key is a toggle key and load in/load out alternately. Pressing this key when the disc is turning stops the disc, then load out the disc. This key operation does not affect the position of the pick-up.

[How to playback a disc in test mode]

In test mode, since the servos operate independently, playing back a disc requires that you operate the keys in the correct order to close the servos.

Here is the key operation sequence for playing back a disc in test mode.

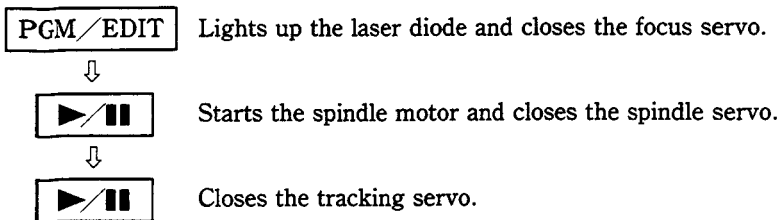

Wait at least 2–3 seconds between each of these operations.

1. Focus Offset Verification

● Objective	Verify the DC offset for the focus error amp.		
● Symptom when out of adjustment	The model does not focus in and the RF signal is dirty.		
● Measurement Instrument Connections	Connect the oscilloscope to TP1, Pin6 (FCS. ERR) and GND is to TP1, Pin4 (VC). [Settings] 5mV/division 10ms/division DC mode	● Player State ● Adjustment Location ● Disc	Test mode, stopped (just the Power switch on) None None needed
[Procedure] Verify the DC voltage at TP1, Pin6 (FCS. ERR) is $0 \pm 50mV$.			

Note: If the specified values cannot be obtained or no adjustment is possible by performing the verifications or adjustments described in adjustment items 1–4, the pickup block may be defective.

2. Tracking Error Balance Verification

● Objective	To verify that there is no variation in the sensitivity of the tracking photo diode.		
● Symptom when out of adjustment	Play does not start or track search is impossible.		
● Measurement Instrument Connections	Connect the oscilloscope to TP1, Pin2 (TRK. ERR) and GND is to TP1, Pin4 (VC). (This connection may be via a low pass filter.) [Settings] 50mV/division 5ms/division DC mode	● Player State ● Adjustment Location ● Disc	Test mode, focus and spindle servos closed and tracking servo open. None YEDS-7
[Procedure] <ol style="list-style-type: none"> 1. Move the pickup to midway across the disc (R=35mm) with the MANUAL/TRACK SEARCH FWD ►► • ►►► key or REV ◄◄◄ • ◄◄◄ key. 2. Press the PGM/EDIT key, then the PLAY/PAUSE ►/ key in that order to close the focus servo then the spindle servo. 3. Line up the bright line (ground) at the center of the oscilloscope screen and put the oscilloscope into DC mode. 4. Supposing that the positive amplitude of the tracking error signal at TP1, pin2 (TRK. ERR) is (A) and the negative amplitude is (B), the following expression is satisfied. 			
$\text{When } A \geq B, \frac{A-B}{C} \times \frac{1}{2} \leq 0.1$ $\text{When } A < B, \frac{B-A}{C} \times \frac{1}{2} \leq 0.1$	<p>When there is a DC component</p>	<p>When there is a DC component</p>	

3. Pickup Radial/Tangential Tilt Adjustment

<ul style="list-style-type: none"> ● Objective 	To adjust the angle of the pickup relative to the disc so that the laser beams are shone straight down into the disc for the best read out of the RF signals.		
<ul style="list-style-type: none"> ● Symptom when out of adjustment 	Sound broken; some discs can be played but not others.		
<ul style="list-style-type: none"> ● Measurement Instrument Connections 	Connect the oscilloscope to TP1, Pin1 (RF) and GND is to TP1, Pin4 (VC). [Settings] 20mV/division 200ns/division AC mode	<ul style="list-style-type: none"> ● Player State ● Adjustment Location ● Disc 	Test mode, play Pickup radial tilt adjustment screw and tangential tilt adjustment screw 8 cm disc [However, those with approx. 20 min of audio signal (music).]

[Procedure]

1. Press the **MANUAL/TRACK SEARCH FWD** key or **REV** key to move the pickup to the external circumference of the disc.
 Press the **PGM/EDIT** key, the **PLAY/PAUSE** key twice in that order to close the respective servos and put the player into play mode.
2. First, adjust the radial tilt adjustment screw with the hexagon wrench (GGK1002) so that the eye pattern (the diamond shape at the center of the RF signal) can be seen the most clearly.
3. Next, adjust the tangential tilt adjustment screw with the hexagon wrench (GGK1002) so that the eye pattern (the diamond shape at the center of the RF signal) can be seen the most clearly (Fig. 3-3).
 ※ The ball-point type hexagonal wrench is used because the disc will get in the way if a normal hexagonal wrench is used.
4. Adjust the radial tilt adjustment screw and the tangential tilt adjustment screw again so that the eye pattern can be seen the most clearly. As necessary, adjust the two screws alternately so that the eye pattern can be seen the most clearly.
5. When the adjustment is completed, lock the radial and tangential adjustment screw.

Note: Radial and tangential mean the directions relative to the disc shown in Fig. 3-2.

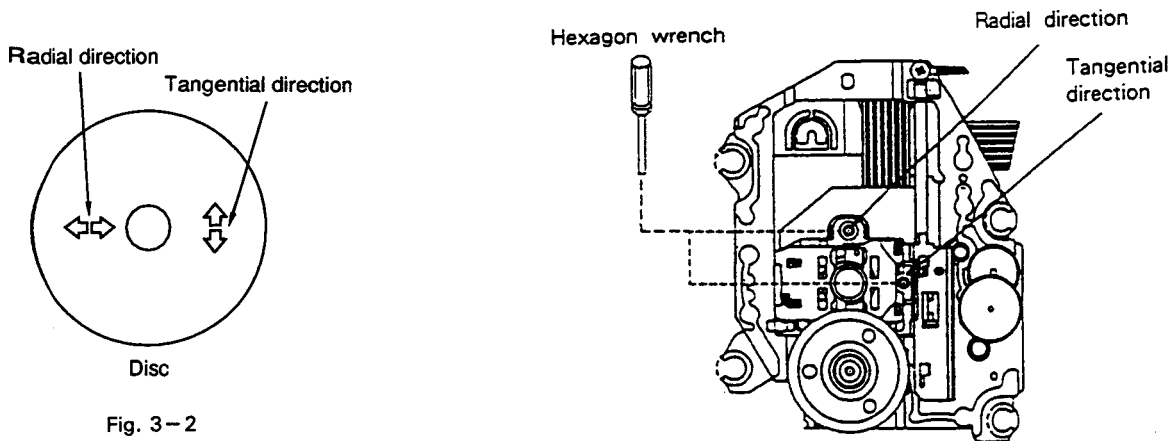

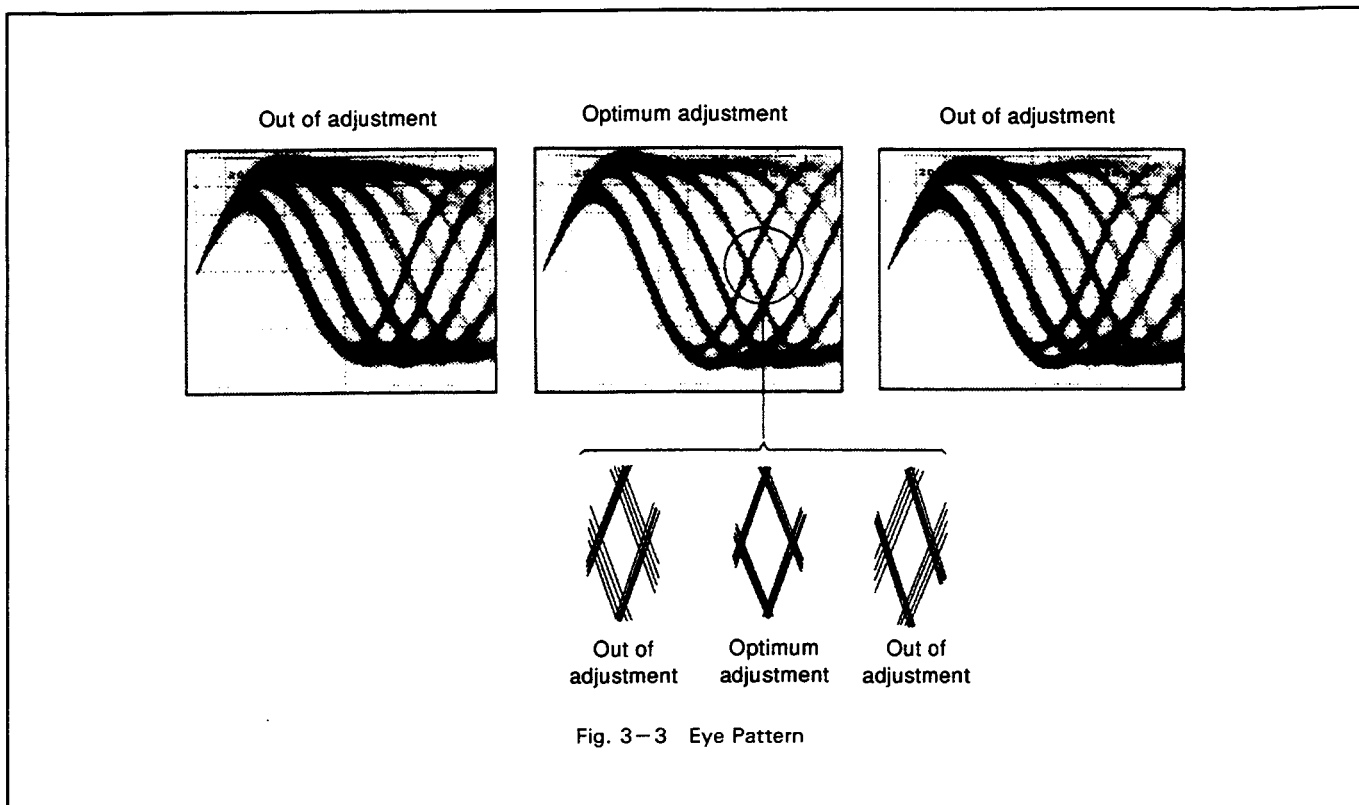

4. RF Level Verification

● Objective	To verify the playback RF signal amplitude.		
● Symptom when out of adjustment	No play or no search		
● Measurement Instrument Connections	Connect the oscilloscope to TP1, Pin1 (RF) and GND is to TP1, Pin4 (VC). [Settings] 50mV/division 10ms/division AC mode	● Player State ● Adjustment Location ● Disc	Test mode, play None YEDS-7
[Procedure]			
<p>1. Move the pickup to midway across the disc (R=35mm) with the MANUAL/TRACK SEARCH FWD ►► •►►► key or REV ◄◄◄ •◄◄◄ key, then press the PGM/EDIT key, the PLAY/PAUSE ►/ key twice in that order to close the respective servos and put the player into play mode.</p> <p>2. Verify the RF signal amplitude is 1.2V_{p-p} ± 0.2V.</p>			

5. Focus Servo Loop Gain Adjustment

● Objective	To optimize the focus servo loop gain.		
● Symptom when out of adjustment	Playback does not start or focus actuator noisy.		
● Measurement Instrument Connections	See Fig. 3-4. [Settings] CH1 20mV/division X-Y mode CH2 5mV/division	● Player State ● Adjustment Location ● Disc	Test mode, play VR152 (FCS. GAN) YEDS-7

[Procedure]

1. Set the AF generator output to 1.2kHz and 1Vp-p.
2. Press the MANUAL/TRACK SEARCH FWD **▶▶▶▶** key or REV **◀◀◀◀** key to move the pickup to halfway across the disc (R=35mm), then press the PGM/EDIT key, the PLAY/PAUSE **▶||** key twice in that order to close the corresponding servos and put the player into play mode.
3. Adjust VR152 (FCS. GAN) so that the Lissajous waveform is symmetrical about the X axis and the Y axis.

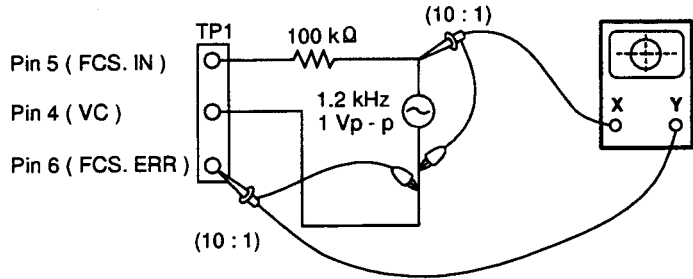
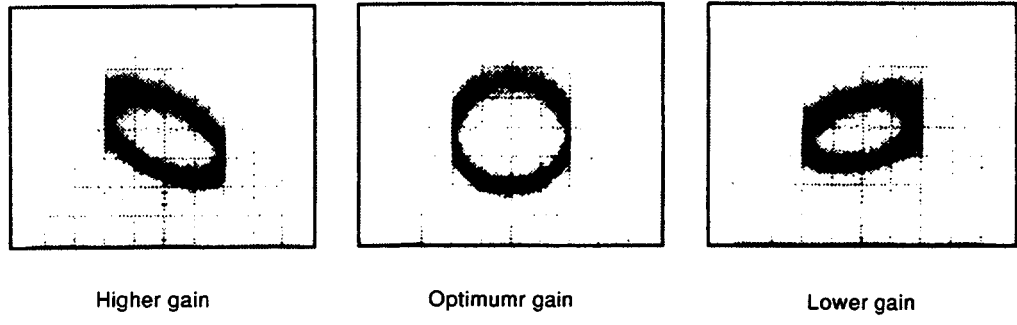

Fig. 3-4

Focus Gain Adjustment



6. Tracking Servo Loop Gain Adjustment

● Objective	To optimize the tracking servo loop gain.		
● Symptom when out of adjustment	Playback does not start, during searches the actuator is noisy, or tracks are skipped.		
● Measurement Instrument Connections	See Fig. 3-5.	● Player State	Test mode, play
	[Settings] CH1 50mV/division X-Y mode CH2 20mV/division	● Adjustment Location	VR151 (TRK. GAN)
		● Disc	YEDS-7

[Procedure]

1. Set the AF generator output to 1.2kHz and 2Vp-p.
2. Press the MANUAL/TRACK SEARCH FWD ►►►•►►► key or REV ◀◀◀•◀◀◀ key to move the pickup to halfway across the disc (R=35mm), then press the PGM/EDIT key, the PLAY/PAUSE ►/■ key twice in that order to close the corresponding servos and put the player into play mode.
3. Adjust VR151 (TRK. GAN) so that the Lissajous waveform is symmetrical about the X axis and the Y axis.

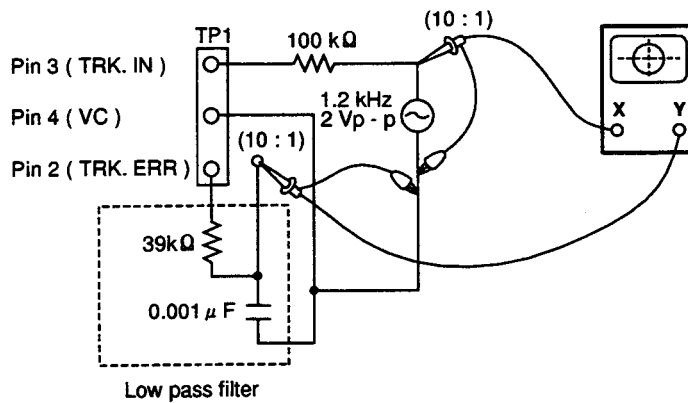
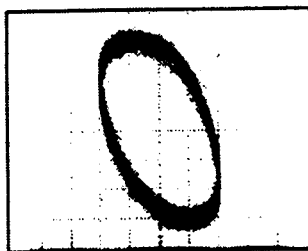
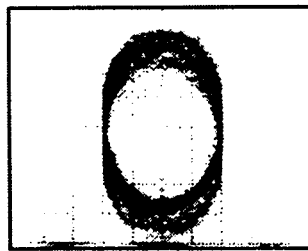

Fig. 3-5

Tracking Gain Adjustment



Higher gain



Optimum gain

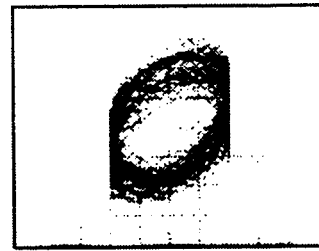

Lower gain

8. IC INFORMATION

- The information shown in the list is basic information and may not correspond exactly to that shown in the schematic diagrams.

■ STK401-060 [IC2201 : MAIN ASSY (A-P550)]

- 2-ch AF power amplifier
- Block Diagram

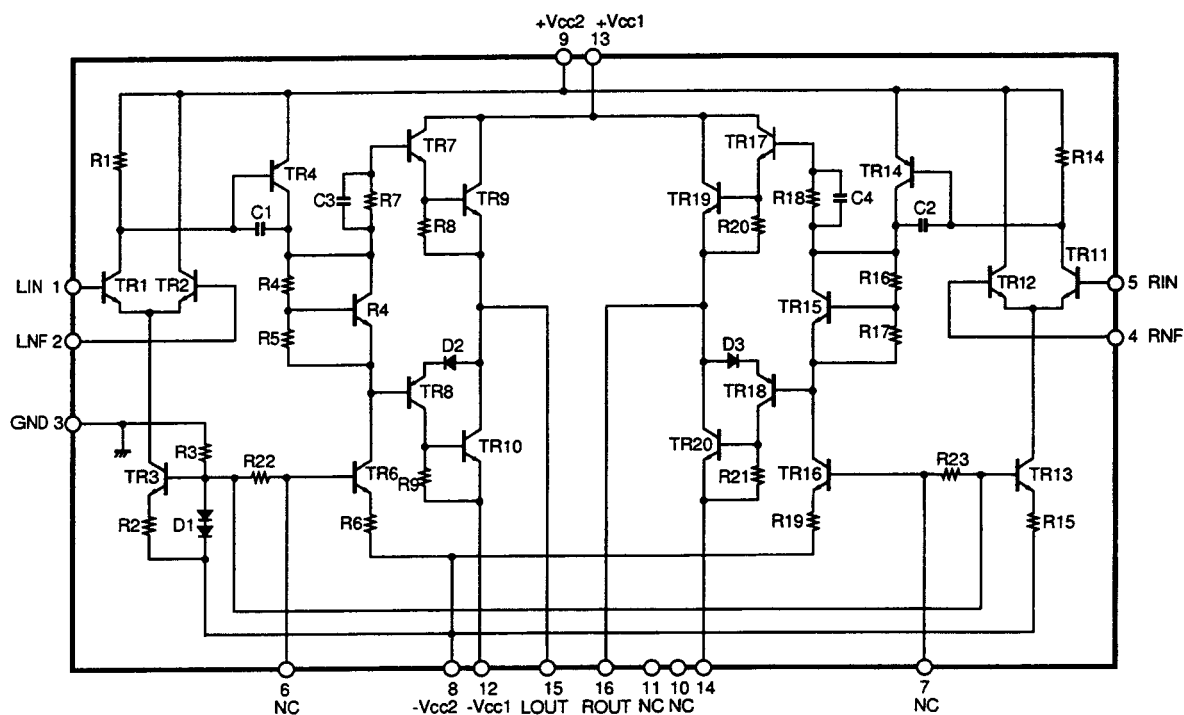

■ BU4052BC [IC3102 : PRE. AMP ASSY (F-P550RDS)]

- Dual 4-ch analog multiplexer
- Block Diagram (Top View)

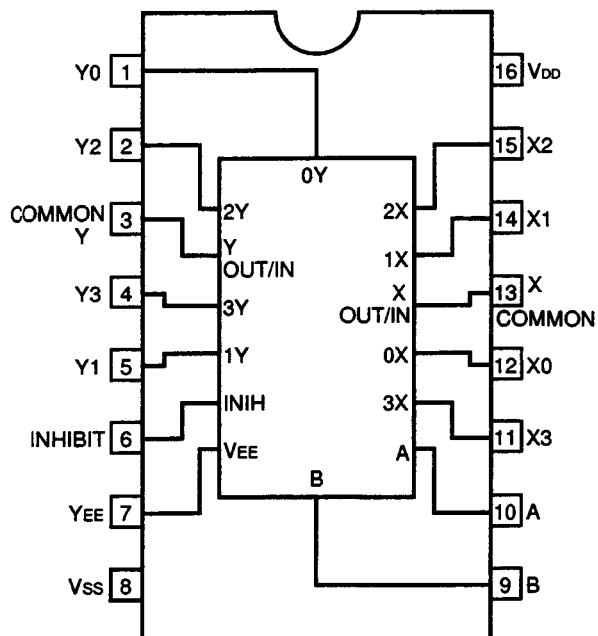

● Truth Table

INHIBIT	A	B	ON SWITCH
L	L	L	X0 Y0
L	H	L	X1 Y1
L	L	H	X2 Y2
L	H	H	X3 Y3
H	X	X	NONE

X : Don't Care

■ PDC023B [IC2501 : DISPLAY ASSY (A – P550)]

● System Control Micro-computer

● Pin Assignment (Top view)

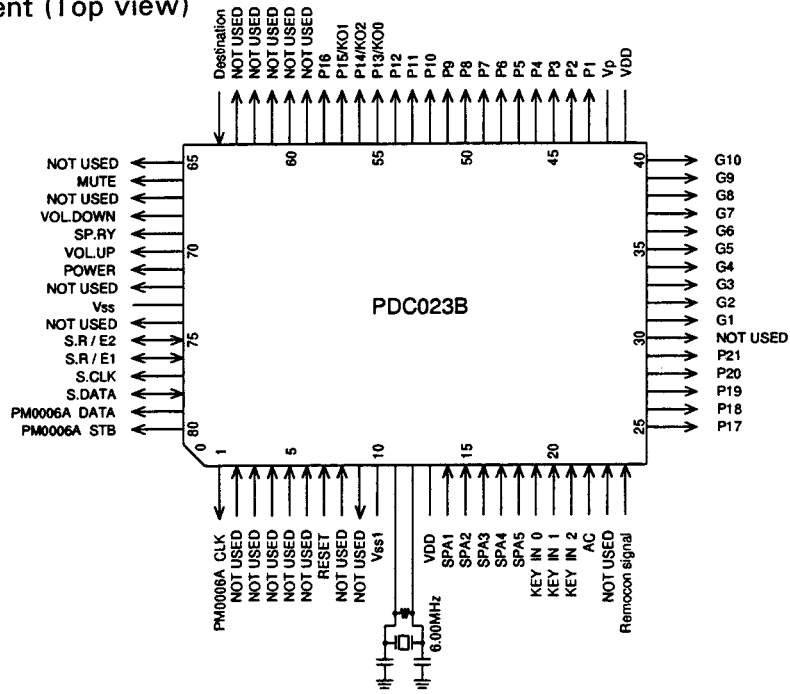

● Pin Function

No.	Pin Name	Pin Function	I/O	Description	Act.
1	P17/PWM0	PM0006A CLK	O	PM0006A clock output	
2 3 4 5	P30 P33	NOT USED	I	Connected to Vss.	
6	P70/INT0	NOT USED	I	Not connect (internal pull-up)	
7	RES	RESET	I	Reset input	
8	XT1/P74	NOT USED	I	Connected to VDD.	
9	XT2/P75	NOT USED	I	Connected to Vss.	
10	Vss1	—	—	Connected to GND.	
11 12	CF1 CF2	—	—	Main system clock (6MHz) Connected to crystal resonator.	
13	VDD1	—	—	Connected to +5V.	
14	P80/AN0	SPA1	I	Spectrum analyzer input (analog) 10kHz	
15	P81/AN1	SPA2	I	Spectrum analyzer input (analog) 3.3kHz	
16	P82/AN2	SPA3	I	Spectrum analyzer input (analog) 1kHz	
17	P83/AN3	SPA4	I	Spectrum analyzer input (analog) 330Hz	

No.	Pin Name	Pin Function	I/O	Description	Act.
18	P84/AN4	SPA5	I	Spectrum analyzer input (analog) 100Hz	
19 21	P85/AN5 P87/AN7	KI0 KI2	I	Key scan • Key return signal input	
22	P71/INT1	AC	I	AC input	
23	P72/INT2/T0IN	NOT USED	I	Not connect (Pull-up at inside)	
24	P73/INT3/T0IN	Remocon signal	I	Remote control signal input	
25 29	S0/T0 S4/T4	P17 P21	O	FL control segment output	
30	S5/T5	NOT USED	O	Not connect	
31 40	S6/T6 S15/T15	G1 G10	O	FL control digit output	
41	VDD2	—	—	Connected to +5V.	
42	VP	—	—	Connected to power supply (−30V) for FDP.	
43 50	S16/PC0 S23/PC7	P1 P8	O	FL control segment output	
51 54	S24/PD0 S27/PD3	P9 P12	O	FL control segment output	
55	S28/PD4	P13/KO1	O	FL control segment output/Key scan strobe output	
56	S29/PD5	P14/KO2			
57	S30/PD6	P15/KO0			
58	S31/PD7	P16	O	FL control segment output	
59 63	S32/PE0 S36/PE4	NOT USED	O	Not connect	
64	S37/PE5	Destination	I	Destination input (J/EX.)	
65	PO0	NOT USED	O	Not connect	
66	PO1	MUTE	O	Line Mute output	H
67	PO2	NOT USED	O	Not connect	
68	PO3	VOL. DOWN	O	Motor volume control output (VOL DOWN)	L
69	PO4	SP. RY	O	Speaker relay control output	H
70	PO5	VOL. UP	O	Motor volume control output (VOL UP)	L

No.	Pin Name	Pin Function	I/O	Description	Act.
71	PO6	POWER	O	Power control output	H
72	PO7	NOT USED	O	Not connect	
73	Vss	—	—	Connected to GND.	
74	P10/SO0	NOT USED	O	Not connect	
75	P11/SI0/SB0	S.R/E2	I/O	Communication request/enable input and output 2 for system bus communication	
76	P12/SCK0	S.R/E1	I/O	Communication request/enable input and output 1 for system bus communication	
77	P13/SO1	S. CLK	O	Clock input and output for system bus communication	
78	P14/SI1/SB1	S. DATA	I/O	Data input and output for system bus communication	
79	P15/SCK1	PM0006A DATA	O	PM0006A data output	
80	P16/BUZ	PM0006A STB	O	PM0006A strobe output	

■ PD4563B [IC3301 : DISPLAY ASSY (F – P550RDS)]

● System Control Micro-computer

● Pin Assignment (Top view)

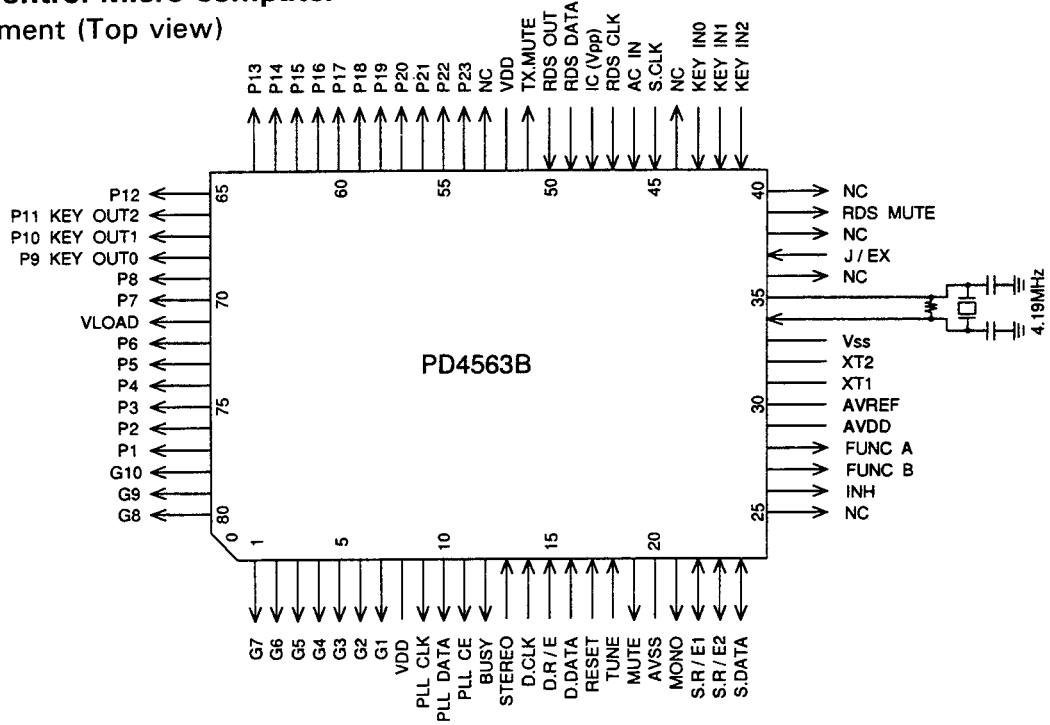

● Pin Function

No.	Pin Name	Pin Function	I/O	Description	Act.
1	P94/FIP6	G7	O	FL control digit output	
5	P90/FIP2	G3			
6	P81/FIP1	G2			
7	P80/FIP0	G1	O	FL control digit output	
8	VDD	-	-	Connected to +5V.	
9	P27/SCK0	PLL CLK	O	PLL LM7001 CLOCK output	
10	P26/SO0/SB1	PLL DATA	O	PLL LM7001 DATA output	
11	P25/SI0/SB0	PLL CE	O	PLL LM7001 CE output	
12	P24/BUSY	BUSY	O	Busy output for system bus communication	
13	P23/STB	STEREO	I	TUNER receive status discrimination	L
14	P22/SCK1	D. CLK	I	Clock input for CD display data communication.	
15	P21/SO1	D. R/E	I	Communication request input for CD display data communication.	
16	P20/SI1	D. DATA	I	Data input for CD display data communication.	
17	RESET	-	I	System reset input	
18	P74	TUNE	I	TUNER tuning status discrimination	L

No.	Pin Name	Pin Function	I/O	Description	Act.
19	P73	MUTE	O	LINE MUTE output	L
20	AVSS	-	-	Connected to GND.	
21	P17/ANI7	MONO	O	MONO output	H
22	P16/ANI6	S. R/E1	I/O	Communication request/enable input and output 1 for system bus communication.	
23	P16/ANI5	S. R/E2	I/O	Communication request/enable input and output 2 for system bus communication.	
24	P14/ANI4	S. DATA	I/O	Data input and output for system bus communication.	
25	P13/ANI3	NOT USED	O	Not connect	
26	P12/ANI2	INH	O	MC14052B output (INH)	
27	P11/ANI1	FUNC B	O	MC14052B output (B)	
28	P10/ANI0	FUNC A	O	MC14052B output (A)	
29	AVDD	-	-	Connected to VDD.	
30	AVREF	-	-	Connected to GND.	
31	P04/XT1	NOT USED	-	Connected to GND.	
32	XT2	NOT USED	-	Not connect	
33	VSS	-	-	Connected to GND.	
34	X1	-	-	Main system clock (4.19 MHz) Connected to crystal resonator.	
35	X2	-	-		
36	P37	NOT USED	O	Not connect	
37	P36/BUZ	J/EX	I	Destination (J/EX) discrimination input	
38	P35/PCL	NOT USED	O	Not connect	
39	P34/T12	RDS MUTE	O	RDS circuit ON/OFF	H
40	P33/T11	NOT USED	O	Not connect	
41 43	P32/TO2 P30/TO0	KI2 KI0	I	Key scan • Key return signal input	
44	P03/INTP3/CI0	NOT USED	O	Not connect	
45	P02/INTP1	S. CLK	I	Data input and output for system bus communication.	
46	P01/INTP1	AC IN	I	AC clock input	
47	P00/INTP0/TI0	RDS CLK	I	RDS clock input	
48	IC (VPP)	-	I	Connected to GND.	

No.	Pin Name	Pin Function	I/O	Description	Act.
49	P72	RDS DATA	I	RDS data input	
50	P71	RDS OUT	I	RDS receive discrimination	
51	P70	TX MUTE	O	Tuner module power ON/OFF	
52	VDD	-	-	Connected to +5V.	
53	P127/FIP33	NOT USED	I	Not connect	
54 60	P126/FIP32 P120/FIP26	P23 P17	O	FL control segment output	
61 65	P117/FIP25 P113/FIP21	P16 P12	O	FL control segment output	
66 68	P112/FIP20 P110/FIP18	P11 P9	O	FL control segment output/key scan strobe output	
69 70	P107/FIP17 P106/FIP16	P8 P7	O	FL control segment output	
71	VLOAD	-	-		
72 77	P105/FIP15 P100/FIP10	P6 P1	O	FL control segment output	
78 80	P97/FIP9 P95/FIP7	G10 G8	O	FL control digit output	

■ PD4564A [IC351 : CD. MAIN ASSY (PD - P550)]

● System Control Micro-computer

● Pin Assignment (Top view)

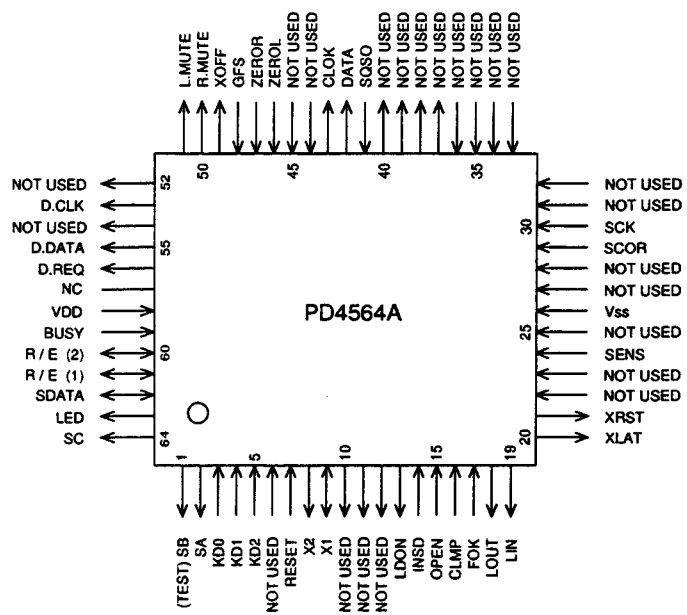

● Key Matrix

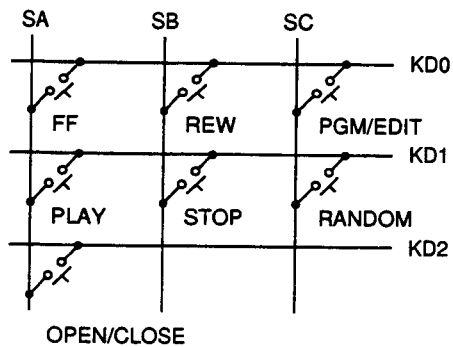

● Pin Function

No.	Pin Name	Pin Function	I/O	Description	Act.
1	P41	SB (TEST)	O	Key scan strobe output (TEST MODE)	H
2	P40	SA	O	Key scan strobe output	H
3	P53	KD0	I	Key scan/key return signal input	
5	P51	KD2			
6	P50	NOT USED	I	Connected to pin 5.	
7	RESET	RESET	I	Micro-computer reset input	L
8	X2	-	-	Connected to ceramic resonator (4.19 MHz).	
9	X1	-			
10	P63	NOT USED	O	Connected to GND.	L
12	P61				
13	P60	LDON	O	Laser diode output	L
14	P73	INSD	I	Slider inside SW input	L
15	P72	OPEN	I	Disc tray OPEN SW input	L
16	P71	CLMP	I	Disc tray CLMP SW input	L

No.	Pin Name	Pin Function	I/O	Description	Act.
17	P70	FOK	I	Focus OK input	H
18	P83	LOUT	O	Disc tray OUT output	L
19	P82	LIN	O	Disc tray IN output	L
20	P81	XLAT	O	CXD2508A latch pulse output	L
21	P80	XRST	O	CXD2508A reset pulse output	L
22	P93	NOT USED	I	Connected to pin 42.	
23	P92				
24	P91	SENS	I	CXD2508A operating status multi-mode input	
25	P90	NOT USED	I	Connected to pin 41.	
26	VSS	VSS	I	Connected to GND.	
27	P13/INT3	NOT USED			
28	P12/INT2				
29	P11/INT1	SCOR	I	Sub cord sync SI+SO input	
30	P10/INT0	SCK	I	System bus clock input	
31	PTH03	NOT USED	I	Connected to GND.	
32	PTH02				
33	PTH01				
34	PTH00				
35	TI0				
36	TI1				
37	P23	NOT USED	O	OPEN	
40	P20				
41	P03	SQSO	I	Sub code Q data serial input	
42	P02	DATA	O	CXD2508A control data serial output	
43	P01	CLOK	O	CXD2508A control serial clock output	
44	P00	NOT USED	I	Connected to GND.	
45	P123	NOT USED	I	Connected to GND. (internal pull-up)	
46	P122	ZEROL	I	Non audio signal detecting input (Lch)	L
47	P121	ZEROR	I	Non audio signal detecting input (Rch)	L
48	P120	GFS	I	Frame sync lock OK input	H

No.	Pin Name	Pin Function	I/O	Description	Act.
49	P133	XOFF	O	CXD2508A oscillation control output (internal pull-up)	H
50	P132	R. MUTE	O	Muting (Rch) output	H
51	P131	L. MUTE	O	Muting (Lch) output	H
52	P130	NOT USED	O	OPEN (internal pull-up)	L
53	P143	D. CLK	O	Display data clock output	
54	P142	NOT USED	O	OPEN (internal pull-up)	L
55	P141	D. DATA	O	Display data output	
56	P140	D. REQ	O	Display data transmission request output	
57	NC	NOT USED	-	Connected to +5V.	
58	VDD	VDD			
59	P33	BUSY	I	System bus talker enable input	H
60	P32	R/E (2)	I/O	System bus request/enable 2 input and output	H
61	P31	R/E (1)	I/O	System bus request/enable 1 input and output	L
62	P30	SDATA	I/O	System bus data input and output	
63	P43	LED	O	Display LED control output	H
64	P42	SC	O	Key scan strobe output	H

■ PD6153A [IC1701 : TC. MAIN ASSY (CT-P550WR)]

● System Control Micro-computer

● Pin Assignment (Top view)

● Key Matrix

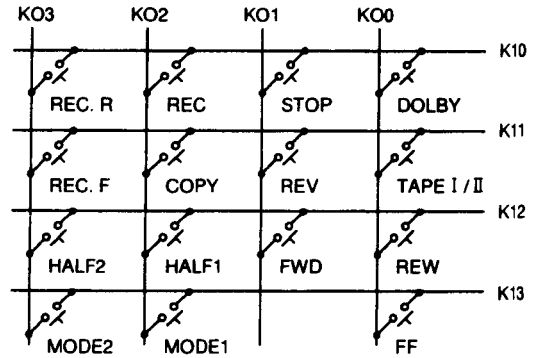
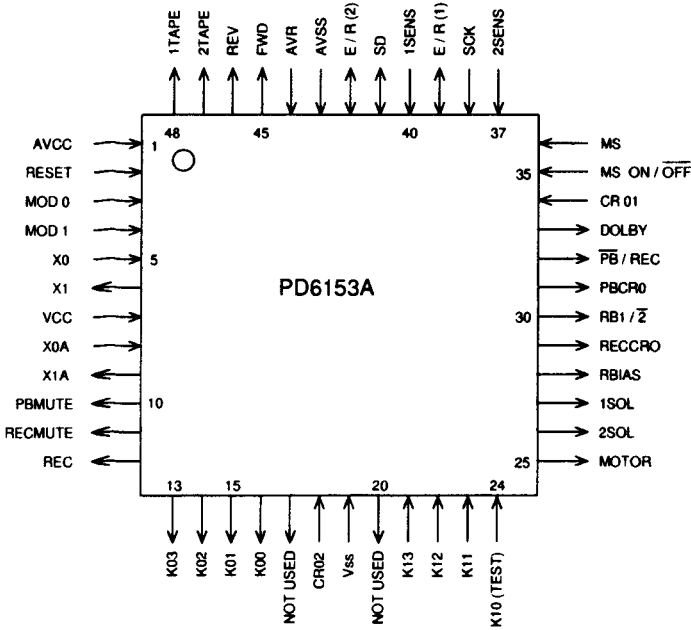

● Pin Function

No.	Pin Name	Pin Function	I/O	Description	Act.
1	AVCC	VCC	-	Connected to +5V.	
2	RST	-	-	Micro-computer reset input	
3	MOD0	-	-	Connected to GND.	
4	MOD1	-	-		
5	X0	-	-	Connected to Ceramic resonator (4.19 MHz).	
6	X1	-	-		
7	VCC	-	-	Connected to +5V.	
8	X0A	-	-	Connected to GND.	
9	X1A	-	-	OPEN	
10	P27	PBMUTE	O	PB MUTE output	H
11	P26	RECMUTE	O	REC MUTE output	H
12	P25	REC (LED)	O	REC LED output	H
13 16	P24 P21	KO3 KO0	O	Key scan strobe output	H
17	P20	NOT USED	O		

No.	Pin Name	Pin Function	I/O	Description	Act.
18	P17	CRO2	I	Mecha II tape type input (internal pull-up)	H
19	VSS	GND	—	Connected to GND.	
20	P16	NOT USED	O	OPEN	
21 23	P15 P13	KI3 KI1	I	Key scan/key return signal input	
24	P12	KI0 (TEST)	I	Key scan/key return signal input (TEST MODE)	
25	P11	MOTOR	O	Motor ON output	H
26	P10	2SOL	O	Mecha II solenoid ON output	H
27	P07	1SOL	O	Mecha I solenoid ON output	H
28	P06	RBIAS	O	Recording bias ON output	H
29	P05	RECCRO	O	CrO2 tape type detecting output when recording.	H
30	P04	PB 1/2	O	Switching playback 1/2 output	
31	P03	PBCRO	O	CrO2 tape type detecting output when playback.	L
32	P02	PB/REC	O	Switching playback/recording output	
33	P01	DOLBY	O	Switching Dolby NR output	H
34	P00	CRO1	I	Mecha I tape type input (internal pull-up)	H
35	P37/BZ	MS ON/OFF	I	Switching MS ON/OFF input (pull-up: +5V)	
36	P36/INT2	MS	I	Audio signal input when MS	H
37	P35/INT1	2SENS	I	Mecha II reel pulse input	H
38	P34/INT0	SCK	I	System bus clock input	
39	P33	E/R (2)	I/O	System bus REQ/ENA 1 input and output	
40	P32	1SENS	I	Mecha I reel pulse input	H
41	P31	SD	I/O	System bus data input and output	
42	P30	E/R (1)	I/O	System bus REQ/ENA 2 input and output	
43	AVSS	VSS	—	Connected to GND.	
44	AVR	VCC	—	Connected to +5V.	
45	P43	1FWD (LED)	O	FWD LED output	L
46	P42	1REV (LED)	O	REV LED output	L
47	P41	2TAPE (LED)	O	TAPE II LED output	L
48	P40	1TAPE (LED)	O	TAPE I LED output	H

LA2232 [IC3201 : PRE. AMP ASSY (F-P550RDS)]

- RDS Signal Demodulator
- Block Diagram

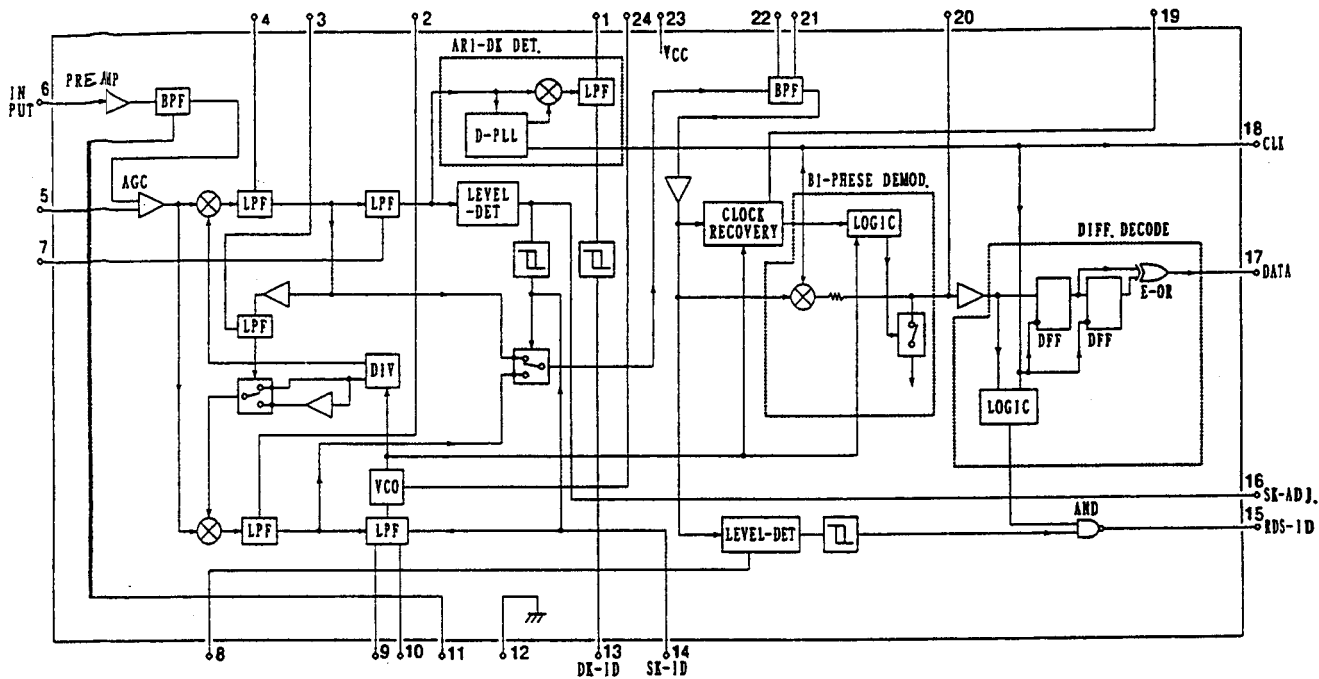

● Pin Function

No.	Pin Name	I/O	Description
1	DK filter	-	Low pass filter for DK detection
2	Q-DET	-	Low pass filter for Quadrature detection
3	NC	-	OPEN, Low pass filter for remodulation comparison
4	I-DET	-	Low pass filter for Synchronous detection
5	BY-PASS	-	Band pass filter check terminal
6	RDS input	I	RDS input terminal
7	SK filter	-	Low pass filter for SK detection
8	RDS filter	-	Low pass filter for RDS detection
9	PLL loop filter	-	Remodulation comparison method PLL loop filter
10			
11	Filter adjustment	-	Band pass filter (57kHz) adjustment terminal
12	GND	-	GND
13	ARI-DK display	O	ARI-DK display terminal

No.	Pin Name	I/O	Description
14	ARI-SK display	O	ARI-SK display terminal
15	RDS display	O	RDS display terminal
16	SK sensitivity adjustment	-	SK sensitivity adjustment terminal
17	DATA	O	DATA output terminal
18	CLK	O	Clock signal output terminal
19	D-PLL	-	Low pass filter for digital PLL for clock playback
20	INTEG/D	-	Capacitor for integration damp
21	B. E. F.	-	Band pass filter for RDS detection
22			
23	Vcc	-	Vcc +5V
24	VCO	-	456 kHz oscillation circuit

9. FL INFORMATION

RAW1141 [V3301 : DISPLAY ASSY (F-P550RDS)]

- FL Tube
- Grid Assignment

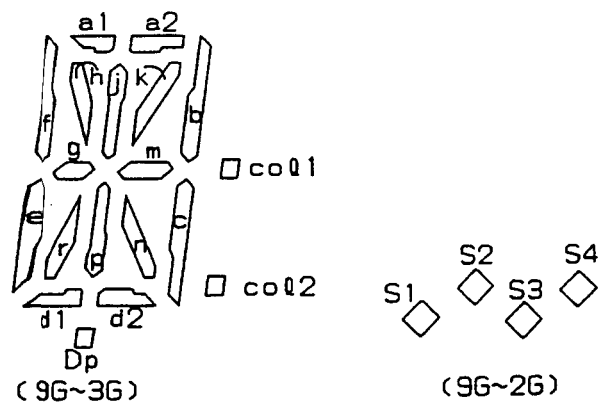
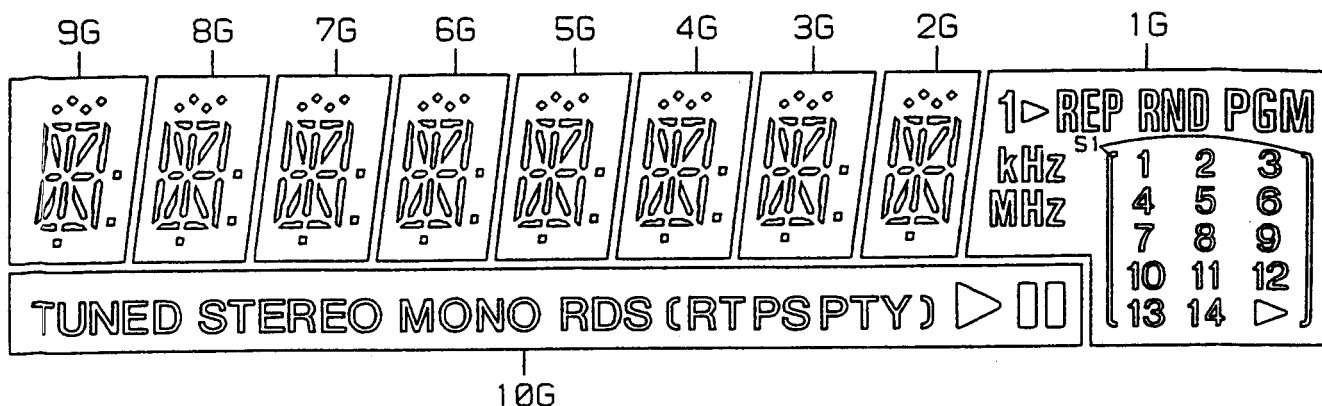

● Anode Connection

	10G	9G~3G	2G	1G
P1	-	S2	S2	1▷
P2	-	S4	S4	REP
P3	-	S1	S1	RND
P4	-	S3	S3	PGM
P5	-	a1	a1	S1
P6	-	a2	a2	1
P7	-	h	h	2
P8	-	j	j	3
P9	-	k	k	4
P10	-	b	b	5
P11	-	f	f	6
P12	-	m	m	7
P13	-	g	g	8
P14	-	col1	-	kHz
P15	STEREO	c	c	9
P16	TUNED	e	e	10
P17	MONO	r	r	11
P18	PTY	p	p	12
P19	PS	n	n	13
P20	RT	col2	-	MHz
P21	RDS (d1	d1	14
P22	▷	d2	d2	▷
P23	□□	Dp	Dp	-

● Pin Assignment

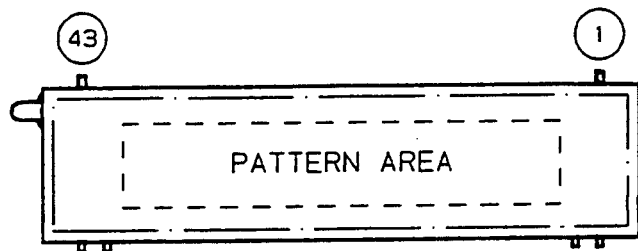

● Pin Connection

- NOTE
- 1) F1, F2 --- Filament
 - 2) NP ----- No pin
 - 3) DL ----- Datum Line
 - 4) 1G~10G --- Grid

PIN NO.	43	42	41	40	39	38	37	36	35	34	33	32	31	30	29	28	27	26	25	24	23	22	21	20	19	18	17	16	15	14	13	12	11	10	9	8	7	6	5	4	3	2	1			
CONNECTION	F	F	N	N	P	P	P	P	P	P	P	P	P	P	P	P	P	P	P	P	P	P	P	P	P	P	N	N	N	1	0	9	8	7	6	5	4	3	2	1	N	N	F	F		
	2	2	P	P	3	2	1	0	9	8	7	6	5	4	3	2	1	0	9	8	7	6	5	4	3	2	1	C	C	G	G	G	G	G	G	G	G	G	G	G	G	G	P	P	1	1

RAWV1142 [V2501 : DISPLAY ASSY (A-P550)]

- FL Tube
- Grid Assignment

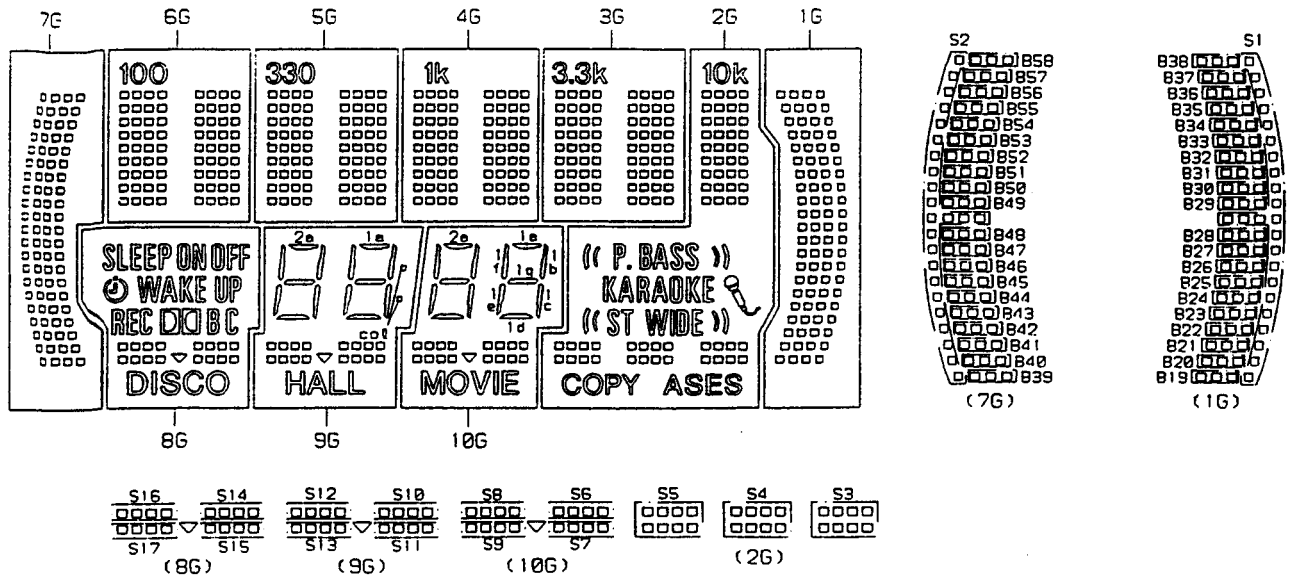

● Anode Connection

	10G	9G	8G	7G	6G	5G	4G	3G	2G	1G
P1	2a	2a	-	B48	-	-	-	-	-	B28
P2	2b	2b	-	B49	-	-	-	-	(P. BASS)	B29
P3	2f	2f	-	B47	B10	B10	B10	B10	(((P. BASS)))	B27
P4	2g	2g	-	B50	B1	B1	B1	B1	B1	B30
P5	2c	2c	-	B46	B11	B11	B11	B11	KARAOKE	B26
P6	2e	2e	-	B51	B2	B2	B2	B2	B2	B31
P7	2d	2d	OFF	B45	B12	B12	B12	B12	(ST WIDE)	B25
P8	-	col	ON	B52	B3	B3	B3	B3	B3	B32
P9	1a	1a	SLEEP	B44	B13	B13	B13	B13	(((ST WIDE)))	B24
P10	1b	1b	⊕	B53	B4	B4	B4	B4	B4	B33
P11	1f	1f	WAKE UP	B43	B14	B14	B14	B14	S3	B23
P12	1g	1g	REC	B54	B5	B5	B5	B5	B5	B34
P13	1c	1c	DO	B42	B15	B15	B15	B15	S4	B22
P14	1e	1e	B	B55	B6	B6	B6	B6	B6	B35
P15	1d	1d	C	B41	B16	B16	B16	B16	S5	B21
P16	S8	S12	S16	B56	B7	B7	B7	B7	B7	B36
P17	S6	S10	S14	B40	B17	B17	B17	B17	ASES	B20
P18	▽	▽	▽	B57	B8	B8	B8	B8	B8	B37
P19	S9	S13	S17	B39	B18	B18	B18	B18	CCPY	B19
P20	S7	S11	S15	B58	B9	B9	B9	B9	B9	B35
P21	MOVIE	HALL	DISCO	S2	100	330	1k	3.3k	10k	S1

● Pin Assignment

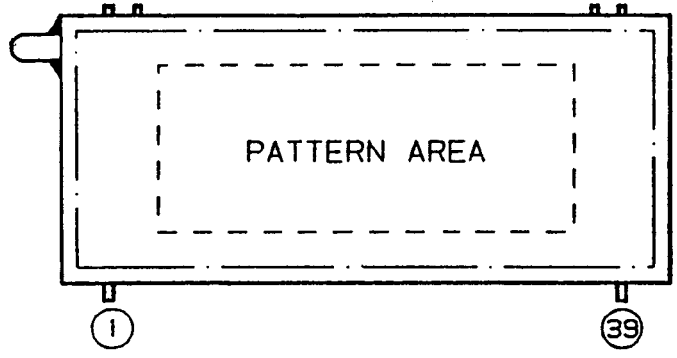

● Pin Connection

- NOTE 1) F1, F2 --- Filament
 2) NP ----- No pin
 3) DL ----- Datum Line
 4) 1G~10G --- Grid

PIN NO.	1	2	3	4	5	6	7	8	9	10	11	12	13	14	15	16	17	18	19	20	21	22	23	24	25	26	27	28	29	30	31	32	33	34	35	36	37	38	39
CONNECTION	F	F	F	N	P	P	P	P	P	P	P	P	P	P	P	P	P	P	P	P	P	P	P	P	P	P	P	P	P	P	P	P	P	P	P	P	P	P	P
	1	1	1	P	8	7	6	5	4	3	2	1	9	8	7	6	5	4	3	2	1	9	8	7	6	5	4	3	2	1	9	8	7	P	2	2	2	2	2

10. DISASSEMBLY

STEREO AMPLIFIER (A-P550)

● Removal of the Front Panel

1. Remove the bonnet.
2. Remove the volume knob.
(Please be careful, as the STA. LENS is in the volume knob.)
3. Remove the screw ① holding the SFC Assy.
4. Remove the left and right screw ② (each one) fixing the front panel to chassis.
5. Remove the three screws ③ at the lower side of the front panel.
6. Disengage the left and the right hook of the front panel (refer to figure) and the hook at the lower part, and then remove the front panel from the chassis.

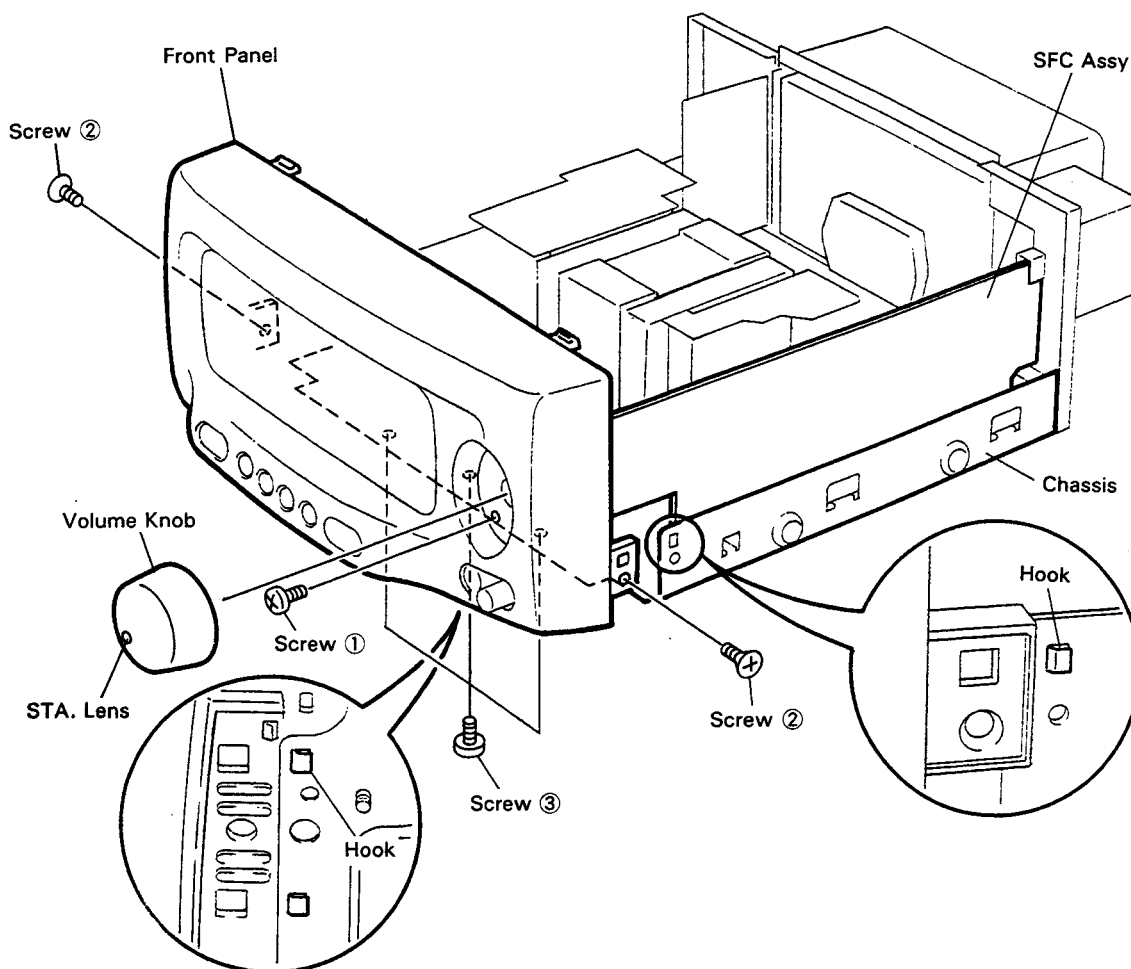

11. PANEL FACILITIES

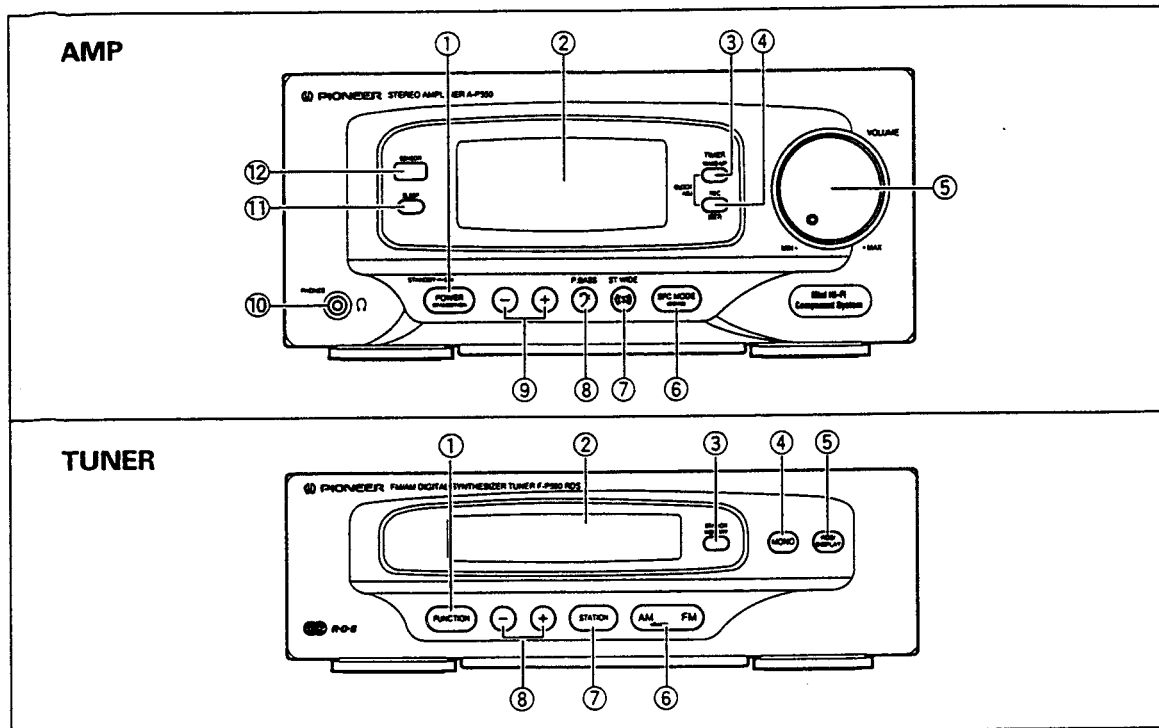

AMP

① POWER STANDBY/ON switch and STANDBY indicator

This is the switch for electric power.

ON: When set to the ON position, power is supplied and the unit becomes operational.

STANDBY: When set to the STANDBY position, the main power flow is cut and the unit is no longer fully operational. A minute flow of power feeds the unit to maintain operation readiness. (The STANDBY indicator lights.)

- ② Display
- ③ TIMER WAKE-UP button
- ④ Timer REC (SET) button
- ⑤ VOLUME control
- ⑥ SFC MODE (DEMO) button
- ⑦ ST WIDE button
- ⑧ P. BASS button
- ⑨ Clock adjust (+, -) buttons
- ⑩ Headphones jack (PHONES)
- ⑪ SLEEP button
- ⑫ Remote sensor (SENSOR)

TUNER

① FUNCTION button

Each time this button is pressed, the function changes in the following sequence (The selected function is displayed in the display window and indicator.):



■ AUTO FUNCTION

This system has an auto tuning function which automatically switches the input source when tape playback, CD play or tuner operation (FM/AM selection) is started.

NOTE:

The function cannot be switched during recording and tape copying.

- ② Display
- ③ STATION MEMORY button
- ④ MONO button
- ⑤ RDS/DISPLAY button
- ⑥ AM/FM button
- ⑦ STATION button
- ⑧ Tuning (+, -) buttons

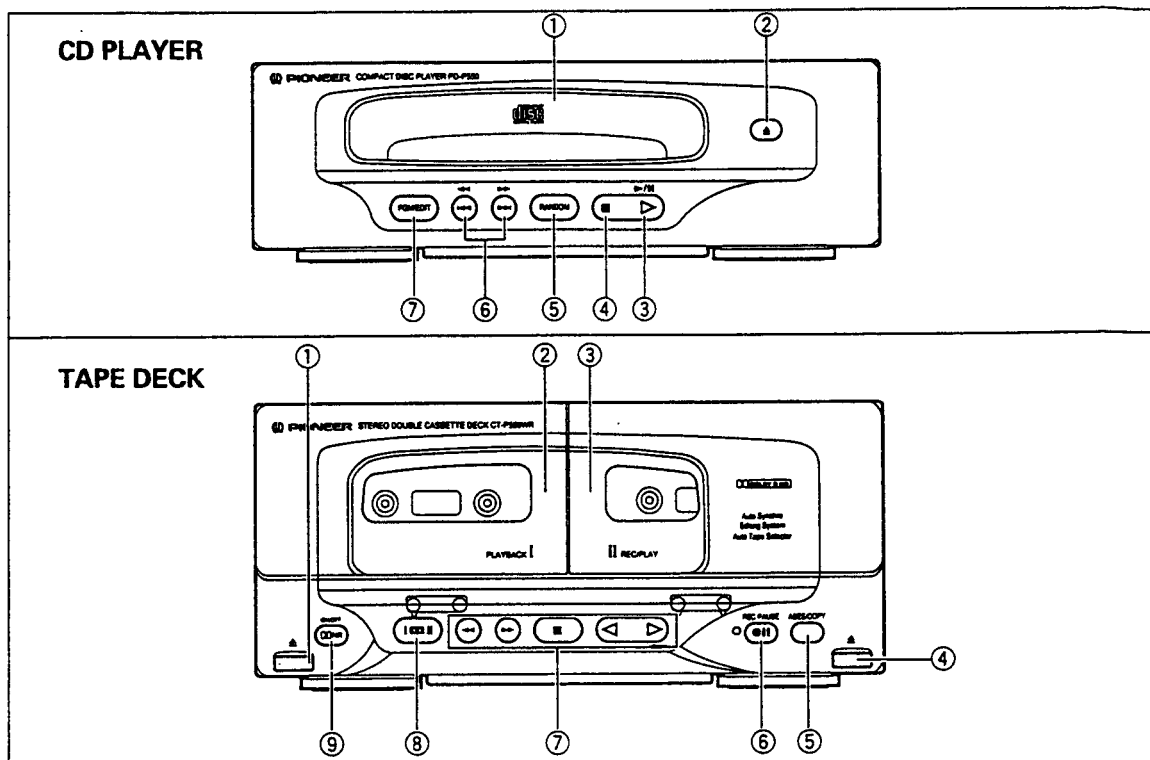

CD PLAYER

- ① Disc tray
- ② Open/close button (▲)
- ③ Play/pause button (▶/⏸)
- ④ Stop button (■)
- ⑤ RANDOM button
- ⑥ Manual/track search buttons (◀◀ ◀▶ ▶▶ ▶▶)
- ⑦ PGM (Program)/EDIT button

TAPE DECK

- ① Tape I eject button (▲)
- ② Tape I cassette door
- ③ Tape II cassette door
- ④ Tape II eject button (▲)
- ⑤ ASES (Auto Synchro Editing System)/COPY button
- ⑥ REC PAUSE button (●||)
- ⑦ Tape operation buttons (Fast◀◀ ▶▶, Stop■, Play◀ ▶)
- ⑧ Tape I/II selector button
- ⑨ Dolby* NR (DNR) ON/OFF button
Each time this button is pressed, Dolby NR system turns ON and OFF.

*

- *Dolby noise reduction manufactured under license from Dolby Laboratories Licensing Corporation.*
- *"DOLBY" and the double-D symbol are trademarks of Dolby Laboratories Licensing Corporation.*

12. SPECIFICATIONS

Amplifier section

Music power (DIN).....	70 W + 70 W
Continuous Power Output (DIN).....	40 W + 40 W (1 kHz, T.H.D. 1%, 8 Ω)
Continuous Power Output (RMS).....	50 W + 50 W (1 kHz, T.H.D. 10%, 8 Ω)
Dimensions.....	260 (W) x 116 (H) x 305 (D)mm
Weight.....	3.8 kg
● Above specifications are for when power supply is 230V.	

FM/AM tuner section

FM Tuner section

Frequency Range.....	87.5 MHz to 108 MHz
Usable Sensitivity.....	Mono: 14.2 dBf, IHF (1.4 μ V/75 Ω)
Antenna Input.....	75 Ω unbalanced

AM Tuner Section

Frequency Range.....	531 kHz to 1,602 kHz
Antenna.....	Loop Antenna
Dimensions.....	260 (W) x 81 (H) x 253 (D)mm
Weight.....	1.4 kg

CD Section

Type.....	Compact disc digital audio system
Wow and Flutter.....	Limit of measurement (\pm 0.001% W.PEAK) or less (EIAJ)
S/N Ratio (EIAJ).....	96 dB
Dimensions.....	260 (W) x 81 (H) x 249 (D)mm
Weight.....	1.8 kg

Cassette deck section

Systems.....	4 track, 2-channel stereo
Heads.....	Recording/playback head x 1 Playback head x 1 Erasing head x 1
Motor.....	DC Servo motor x 1
Wow and Flutter.....	No more than 0.1%(WRMS)
Frequency Response (-20 dB recording) :	
TYPE II	
(HIGH/CrO ₂) tape.....	35 Hz to 15,000 Hz \pm 6 dB
TYPE I	
(Normal) tape.....	35 Hz to 14,000 Hz \pm 6 dB
Signal-to Noise Ratio	
Dolby NR OFF.....	56 dB
Noise Reduction Effect	
Dolby B type NR ON.....	More than 10 dB (at 5 kHz)
Dimensions.....	260 (W) x 116 (H) x 245 (D)mm
Weight.....	2.4 kg

Miscellaneous

Power Requirements

European model.....	AC. 220-230 V, 50/60 Hz
U.K. model.....	AC. 230V, 50/60Hz
Power Consumption.....	240 W

Accessories

Operating Instructions.....	1
Remote Control Unit.....	1
Dry Cell Batteries (AAA/R03).....	2
FM T-type Antenna.....	1
AM Loop Antenna.....	1
System Cable.....	1
Speaker Cords (supplied with speaker system).....	2
Warranty card.....	1

NOTE:

Specifications and design subject to possible modification without notice, due to improvements.