

CASSETTE TAPE DECK
CT-F9191
FV, KCU

<ART-138>

Service Manual

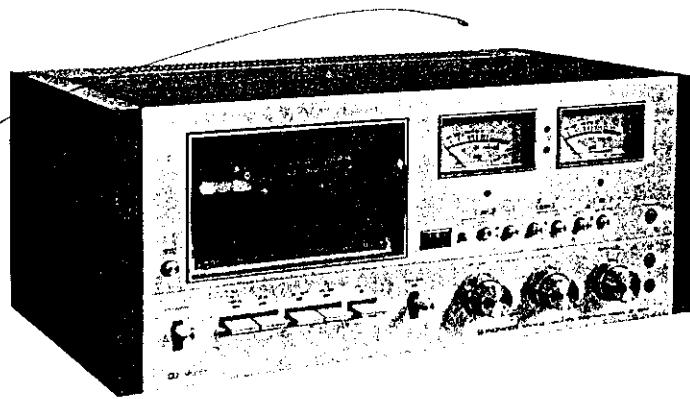

 **PIONEER®**

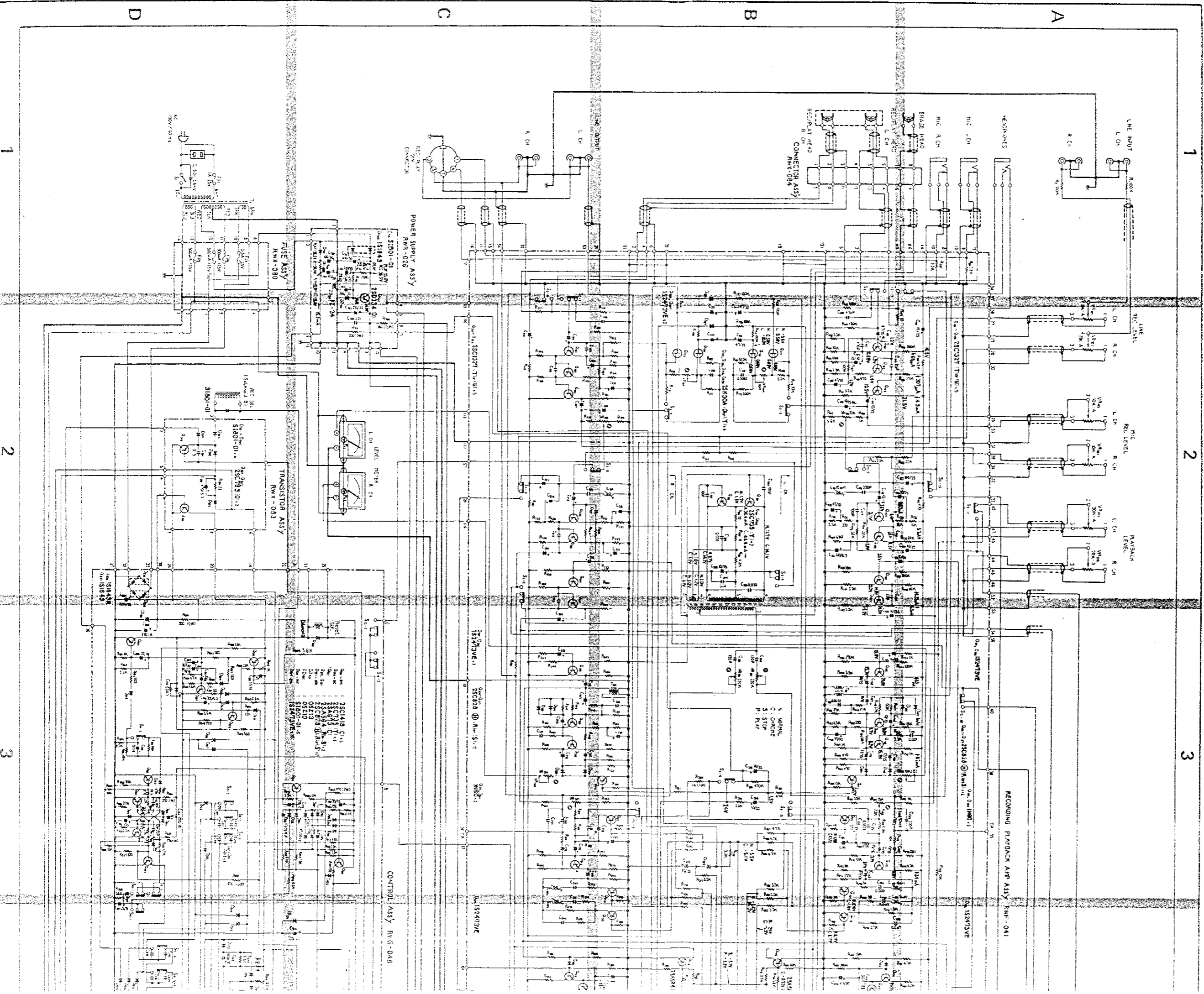

1

2

3

A

B

C

D

1

2

3

4

5

6

4

5

6

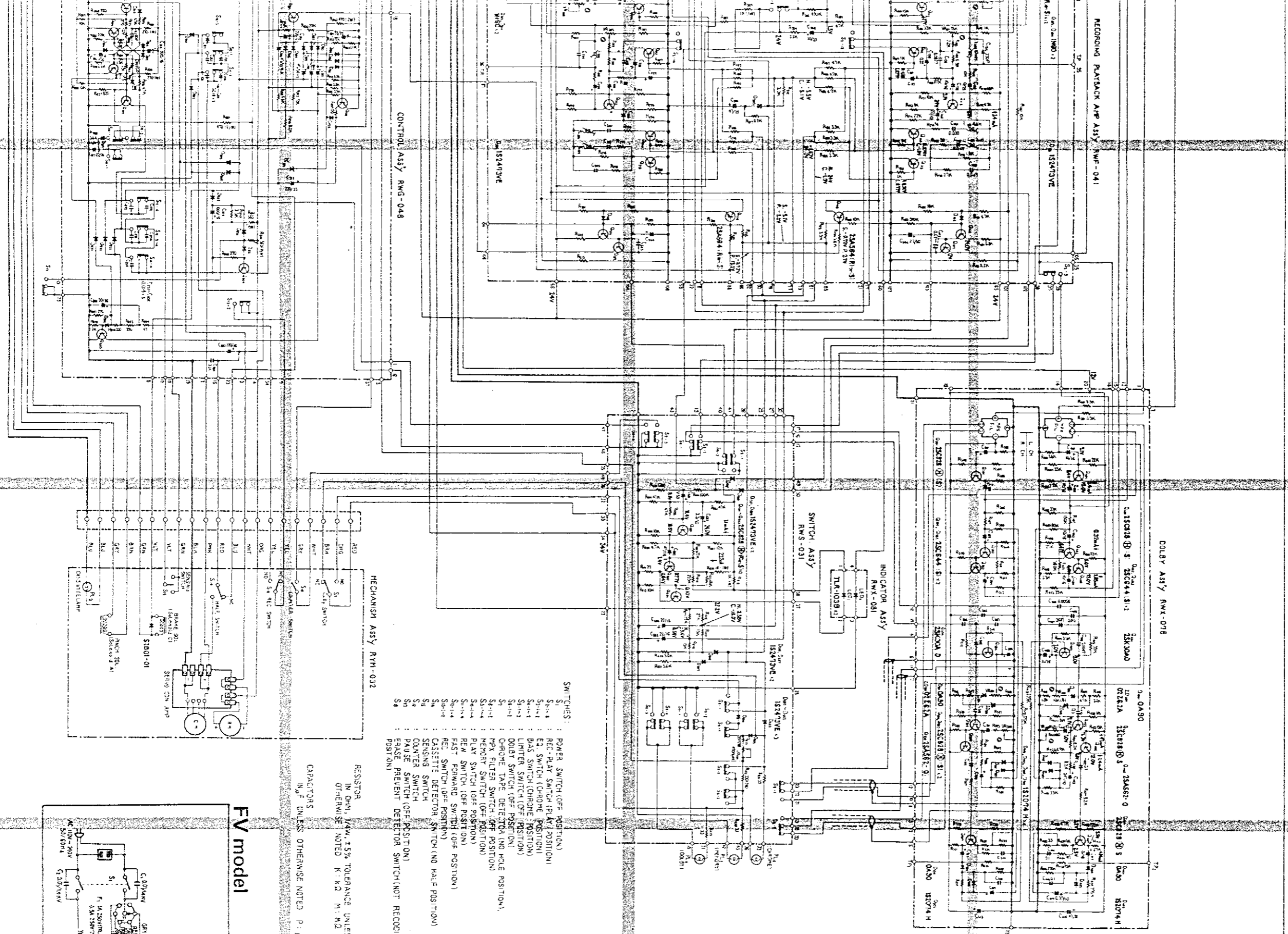

- SWITCHES:
- S1 : POWER SWITCH (OFF POSITION)
 - S1-a : REC-PLAY SWITCH (PLATE POSITION)
 - S1-b : EQ. SWITCH (CHROME POSITION)
 - S1-c : BIAS SWITCH (CHROME POSITION)
 - S1-d : LIMITER SWITCH (OFF POSITION)
 - S1-e : DOLBY SWITCH (OFF POSITION)
 - S1-f : CHROME TAPE DETECTOR (NO HOLE POSITION)
 - S1-g : MPX FILTER SWITCH (OFF POSITION)
 - S1-h : MERRIT SWITCH (OFF POSITION)
 - S1-i : PLAY SWITCH (OFF POSITION)
 - S1-j : REW. SWITCH (OFF POSITION)
 - S1-k : FAST FORWARD SWITCH (OFF POSITION)
 - S1-l : REC. SWITCH (OFF POSITION)
 - S1-m : CASSETTE DETECTOR SWITCH (NO HALF POSITION)
 - S1-n : SENSING SWITCH
 - S1-o : COUNTER SWITCH
 - S1-p : PAUSE SWITCH (OFF POSITION)
 - S1-q : ERASE PREVENT DETECTOR SWITCH (NOT RECORDING POSITION)

RESISTOR
IN OHM, 1/4W, ±5% TOLERANCE UNLESS
OTHERWISE NOTED K: KΩ M: MΩ

CAPACITORS
M, F UNLESS OTHERWISE NOTED P: pF

FV model

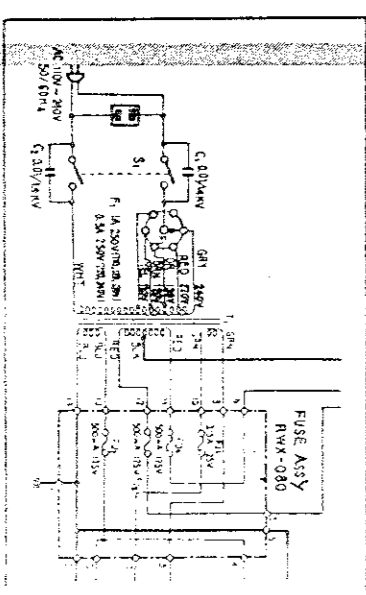

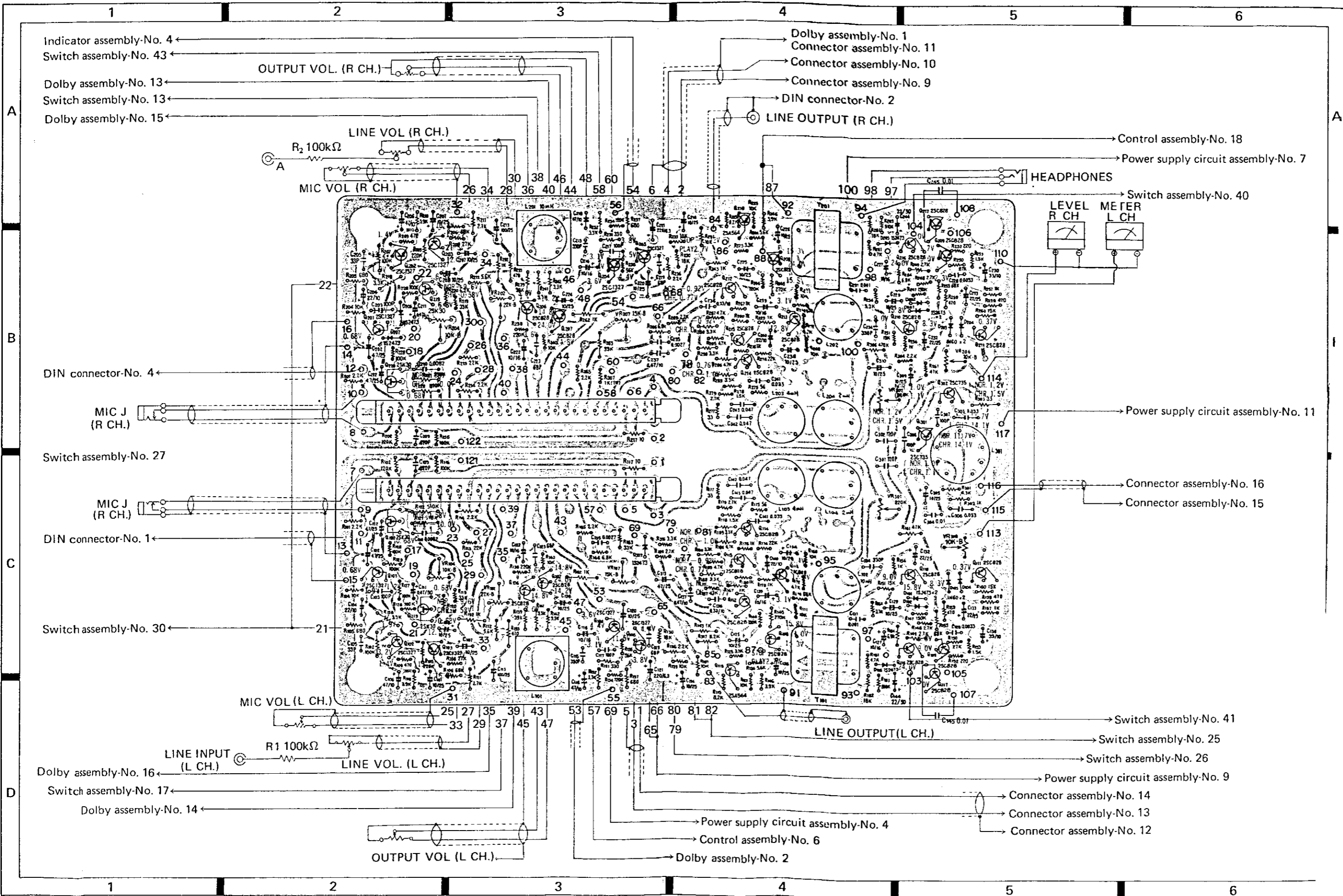

11.5 DOLBY PROCESSER ASSEMBLY (RWX-078)

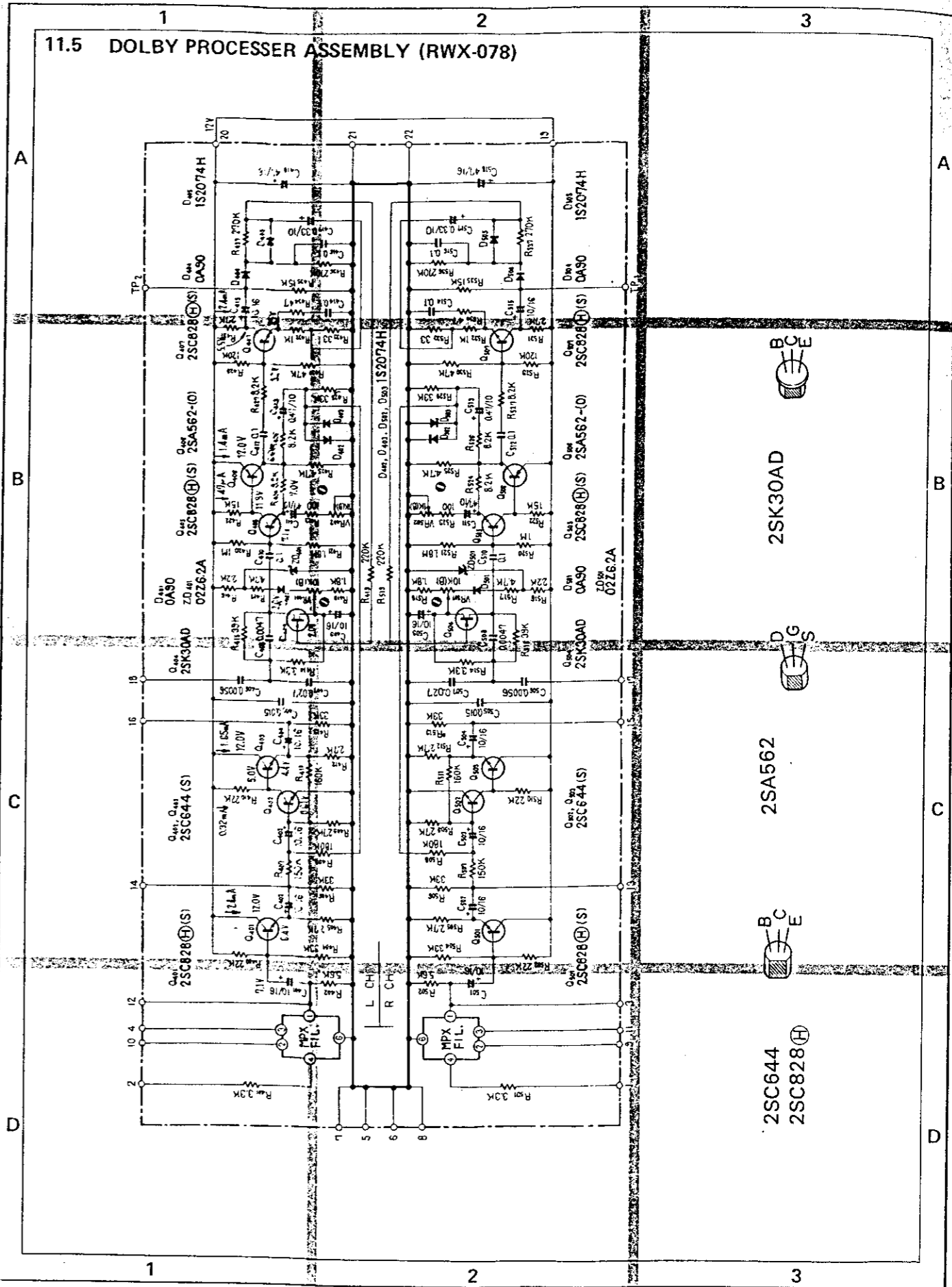

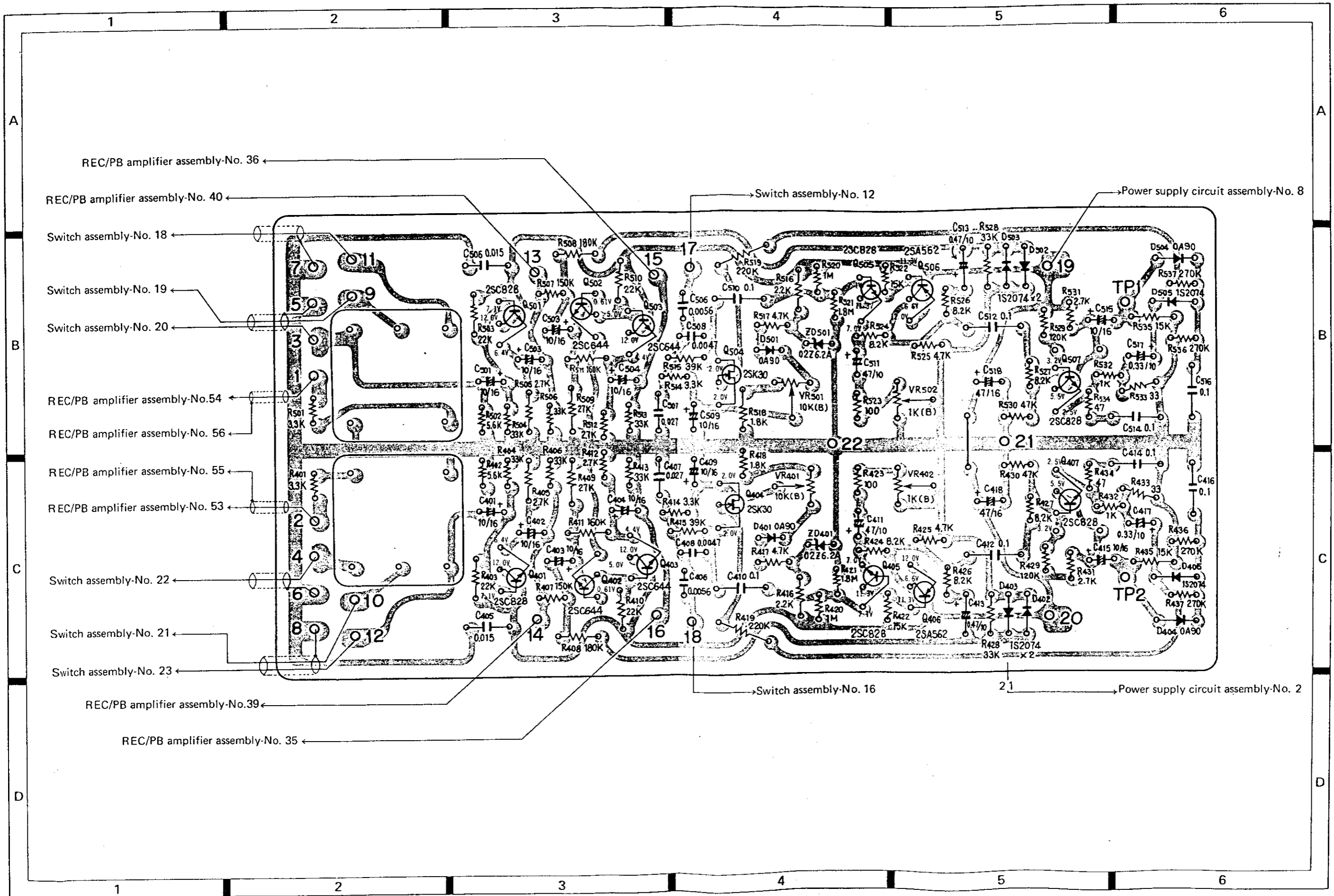

11.6 FUSE ASSEMBLY (RWX-080)

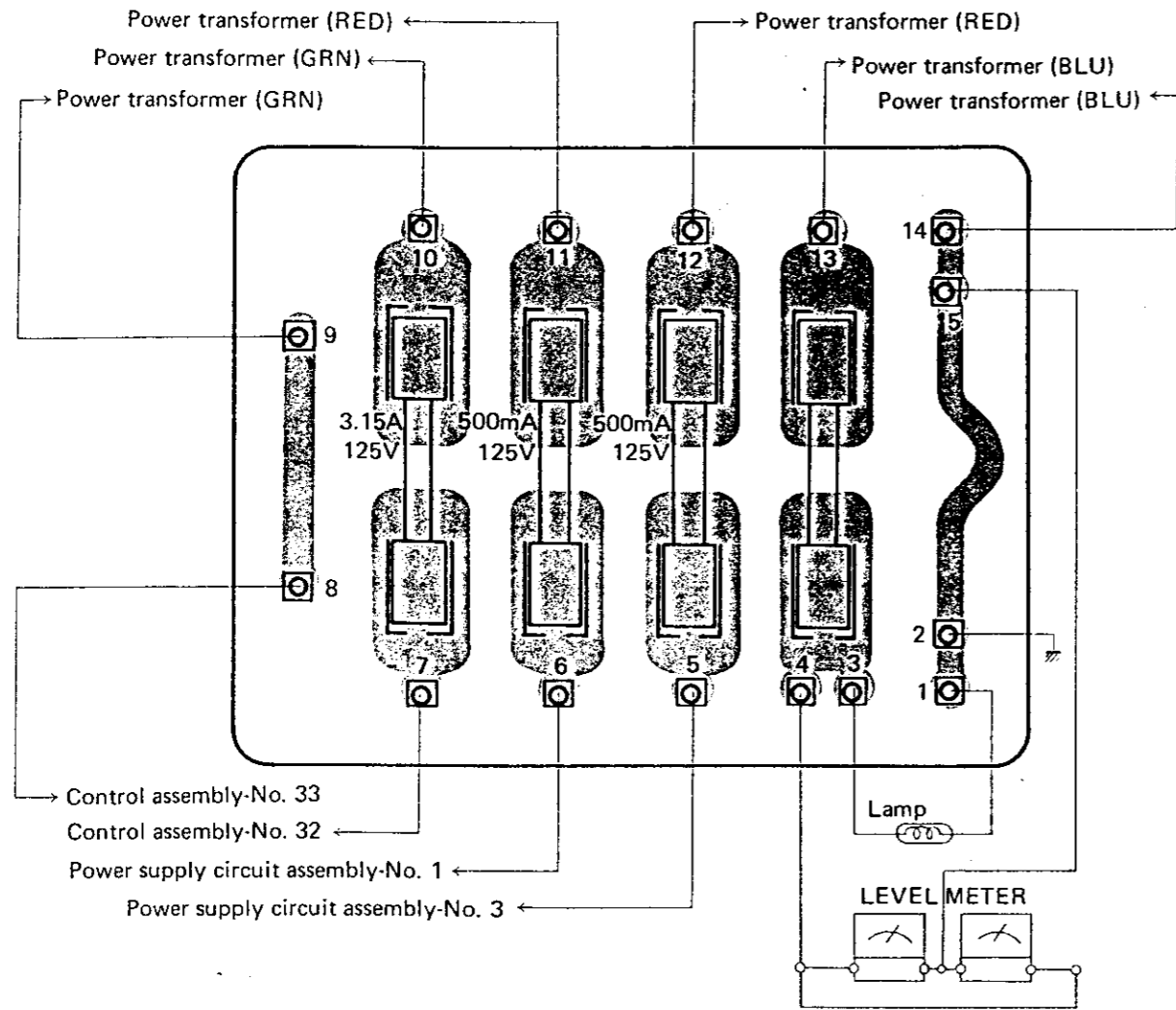

Parts List of Fuse Assembly (RWX-080)

CAPACITORS

Symbol	Description	Part No.
	Fuse clip	RKR-017
	Fuse 500mA	REK-048
	Fuse 3.15A (Surge proof)	REK-044

11.7 CONTROL ASSEMBLY (RWG-048)

NOTE: The voltage values in circuit diagram are expressed on page 70.

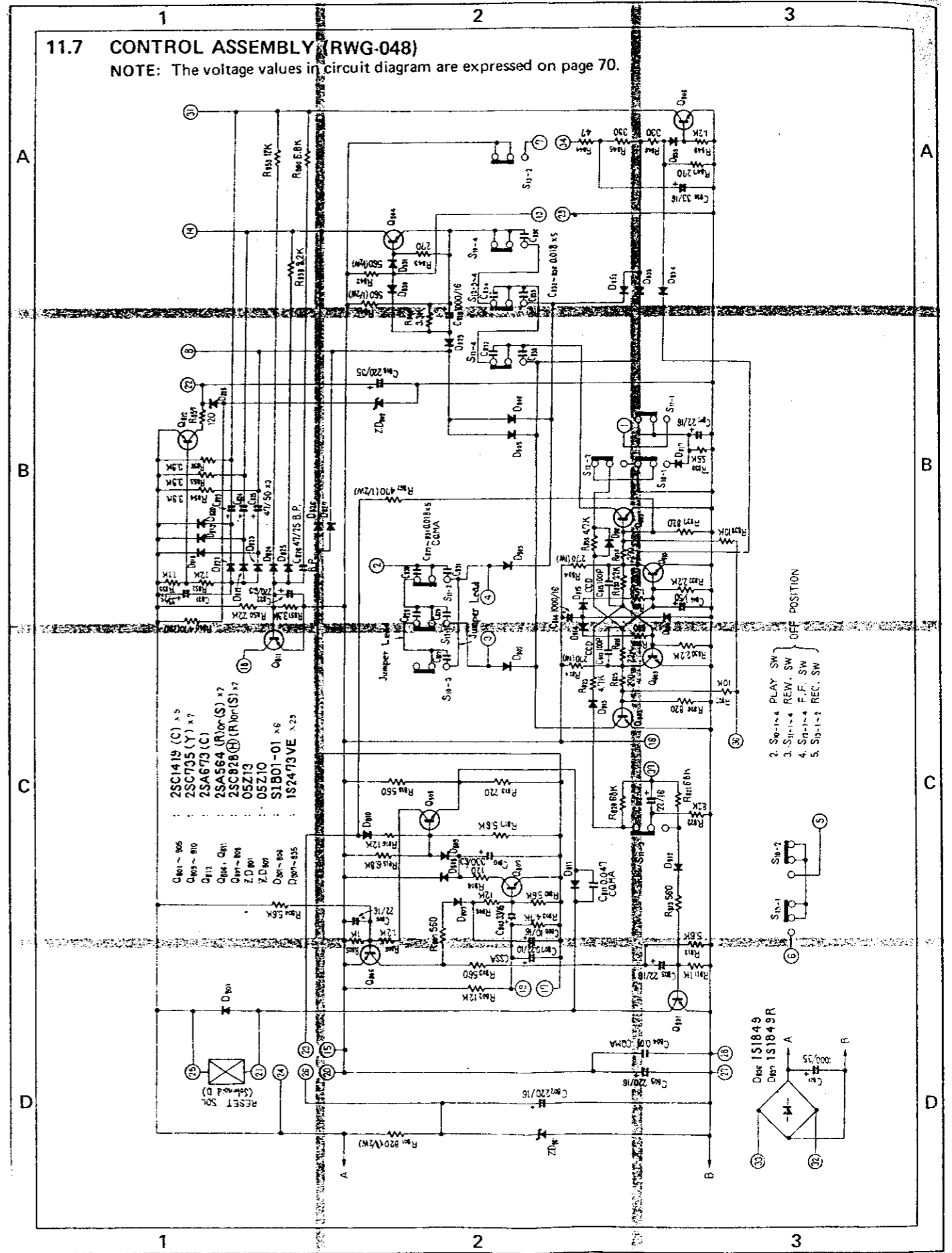

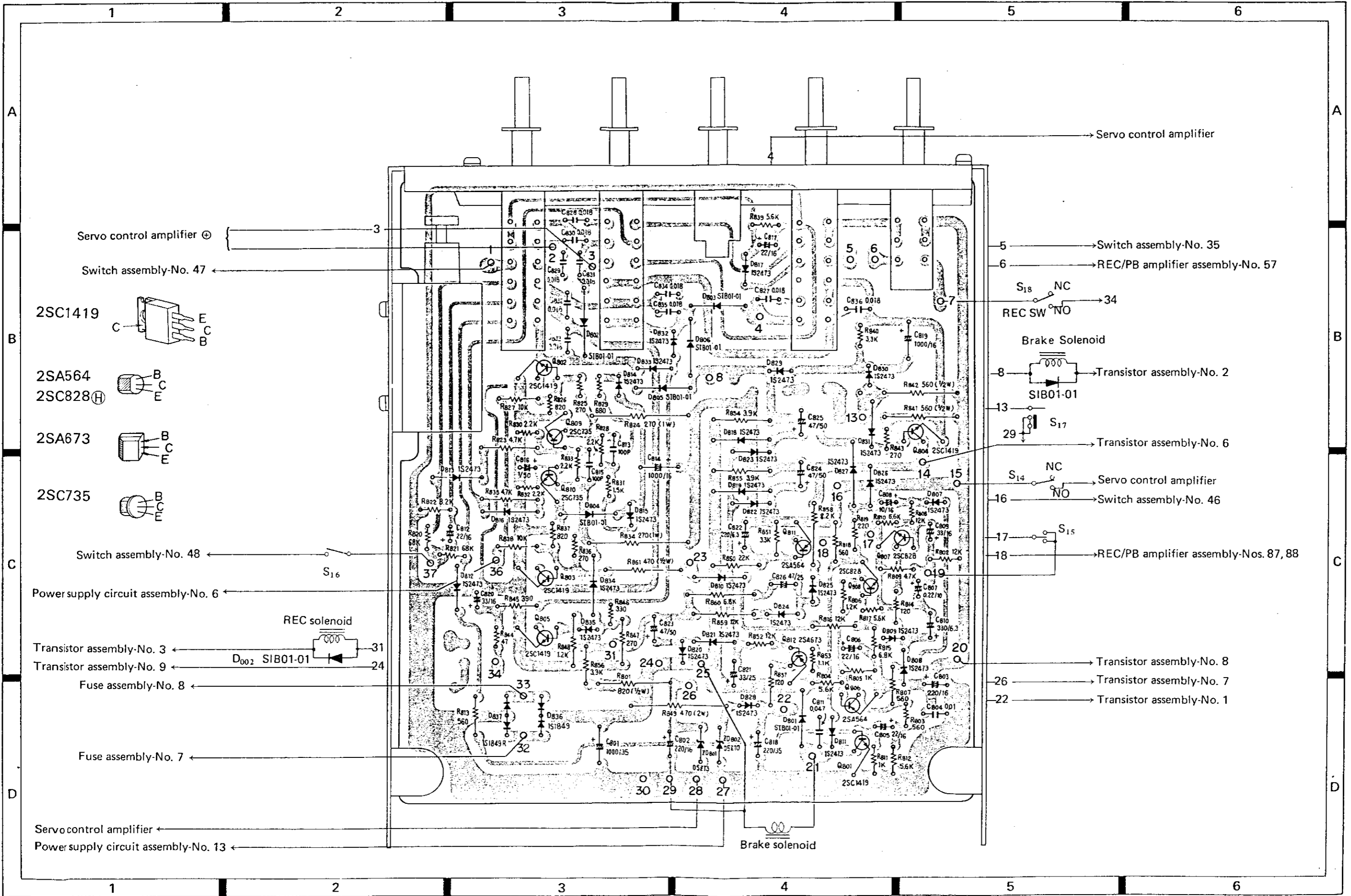

Servo control amplifier

Servo control amplifier ⊕

Switch assembly-No. 47

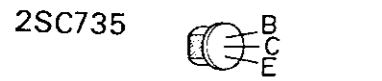
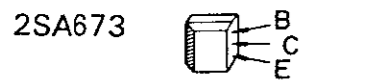
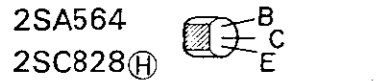
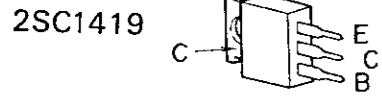

Switch assembly-No. 48

Power supply circuit assembly-No. 6

REC solenoid

Transistor assembly-No. 3

Transistor assembly-No. 9

Fuse assembly-No. 8

Fuse assembly-No. 7

Servo control amplifier

Power supply circuit assembly-No. 13

Switch assembly-No. 35

REC/PB amplifier assembly-No. 57

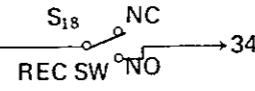

Brake Solenoid

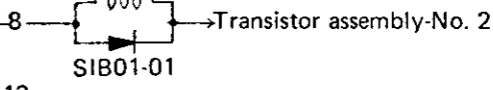

Transistor assembly-No. 6



Servo control amplifier

Switch assembly-No. 46

REC/PB amplifier assembly-Nos. 87, 88

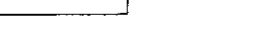

Transistor assembly-No. 8

Transistor assembly-No. 7

Transistor assembly-No. 1

Brake solenoid

11.8 TRANSISTOR ASSEMBLY (RWX-083)

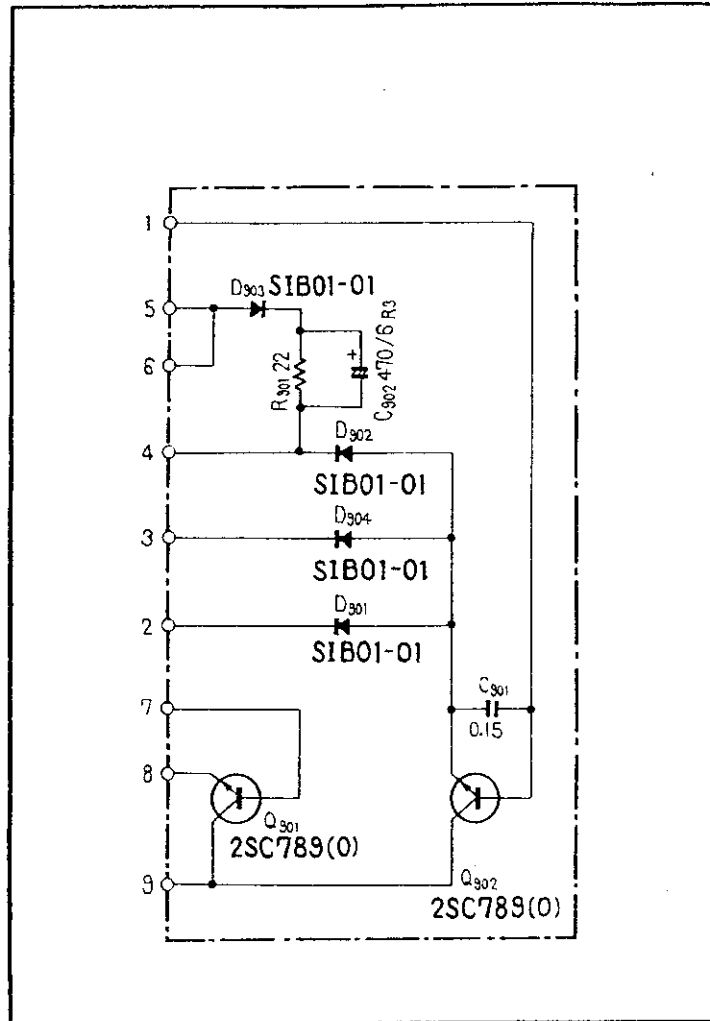

Parts List of Transistor Assembly (RWX-083)

CAPACITORS

Symbol	Description	Part No.
C901	Mylar 0.15 50V	CQMA 154K 50
C902	Electrolytic 470 6.3V	CEA 471P 6R3

RESISTORS

Symbol	Description	Part No.
R901	Carbon film 22	RD¼VS 220J

SEMICONDUCTORS

Symbol	Description	Part No.
D901	Diode S1B01-01	
R902	Diode S1B01-01	
R903	Diode S1B01-01	
R904	Diode S1B01-01	
Q901	Transistor 2SC789-0	
Q902	Transistor 2SC789-0	

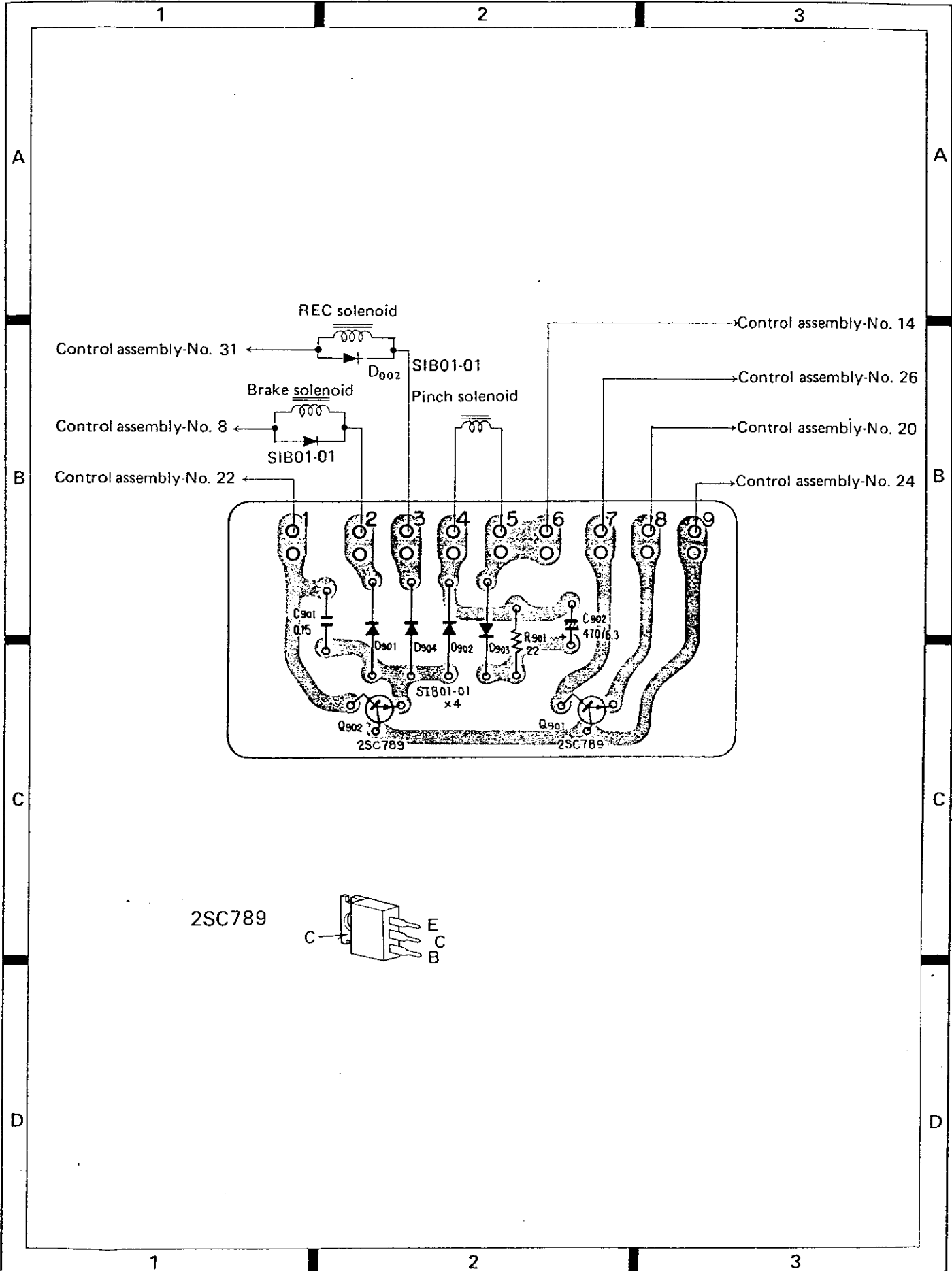

11.9 SWITCH ASSEMBLY (RWS-031)

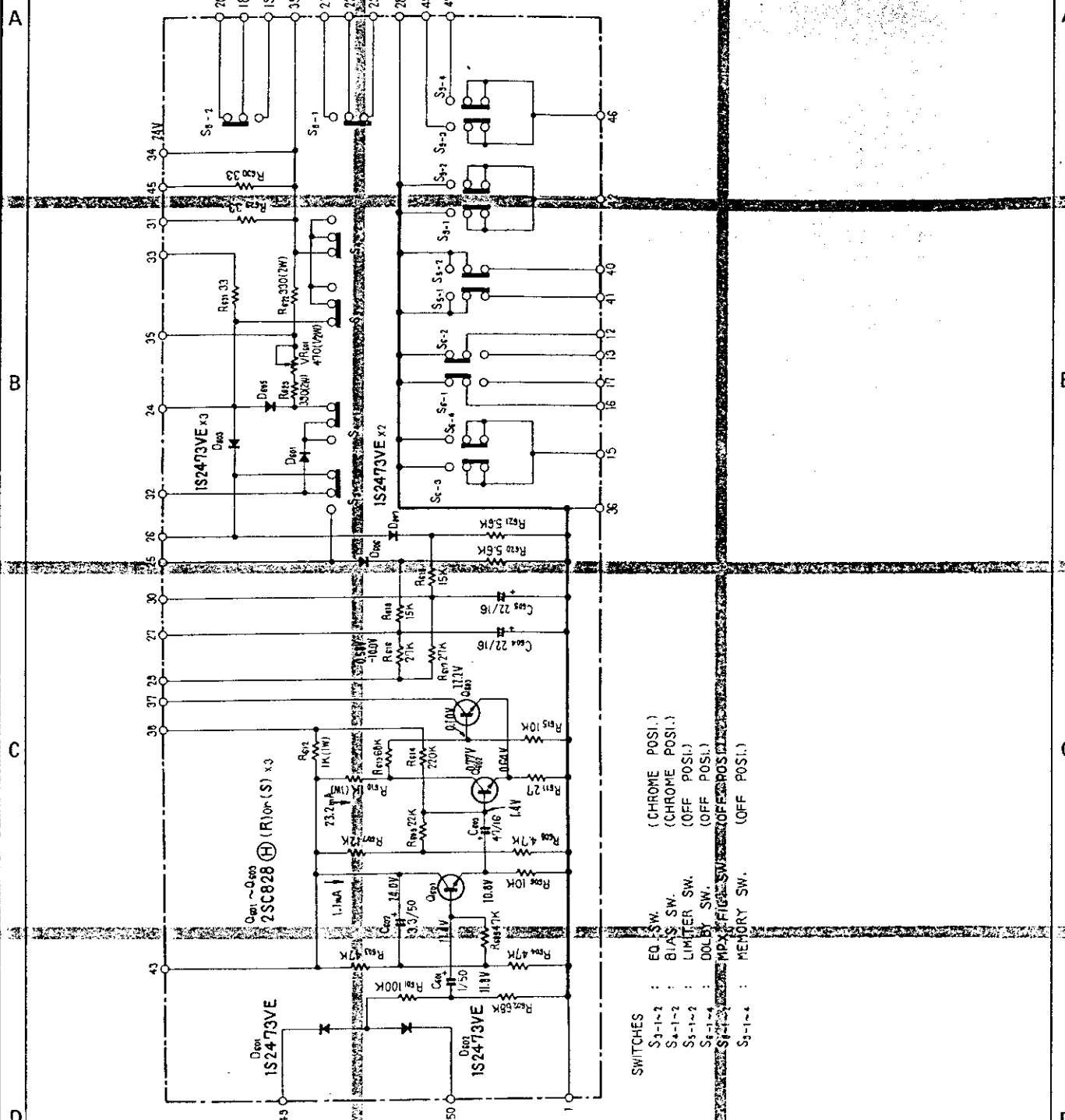

- SWITCHES**
- S₃₋₁₋₂ : EQ. SW. (CHROME POSI.)
 - S₄₋₁₋₂ : BIAS SW. (CHROME POSI.)
 - S₅₋₁₋₂ : LIMITER SW. (OFF POSI.)
 - S₅₋₁₋₃ : DOLBY SW. (OFF POSI.)
 - S₅₋₁₋₄ : MPX. FTG. SW. (OFF POSI.)
 - S₅₋₁₋₅ : MEMORY SW. (OFF POSI.)

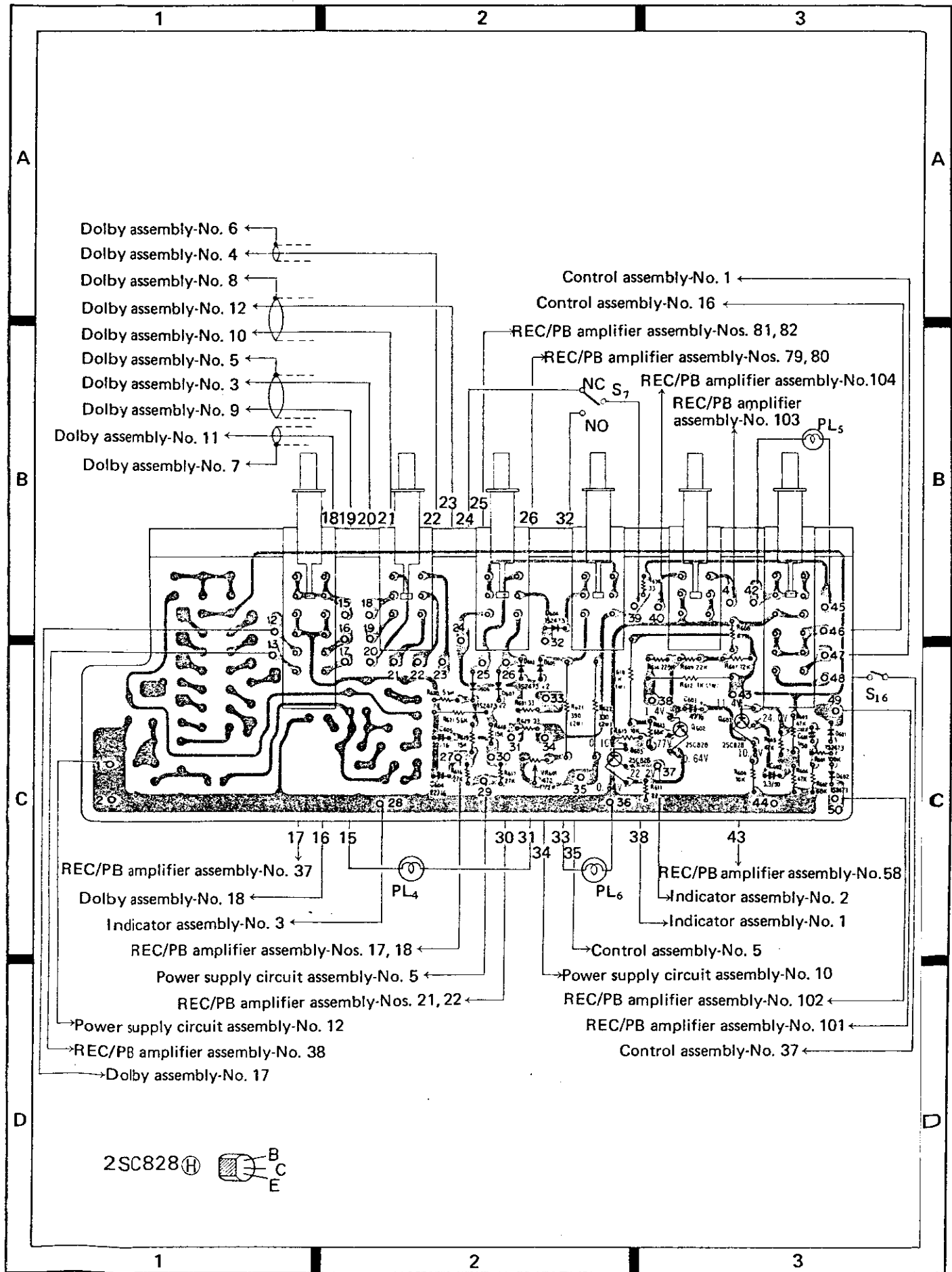

11.10 POWER SUPPLY ASSEMBLY (RWR-026)

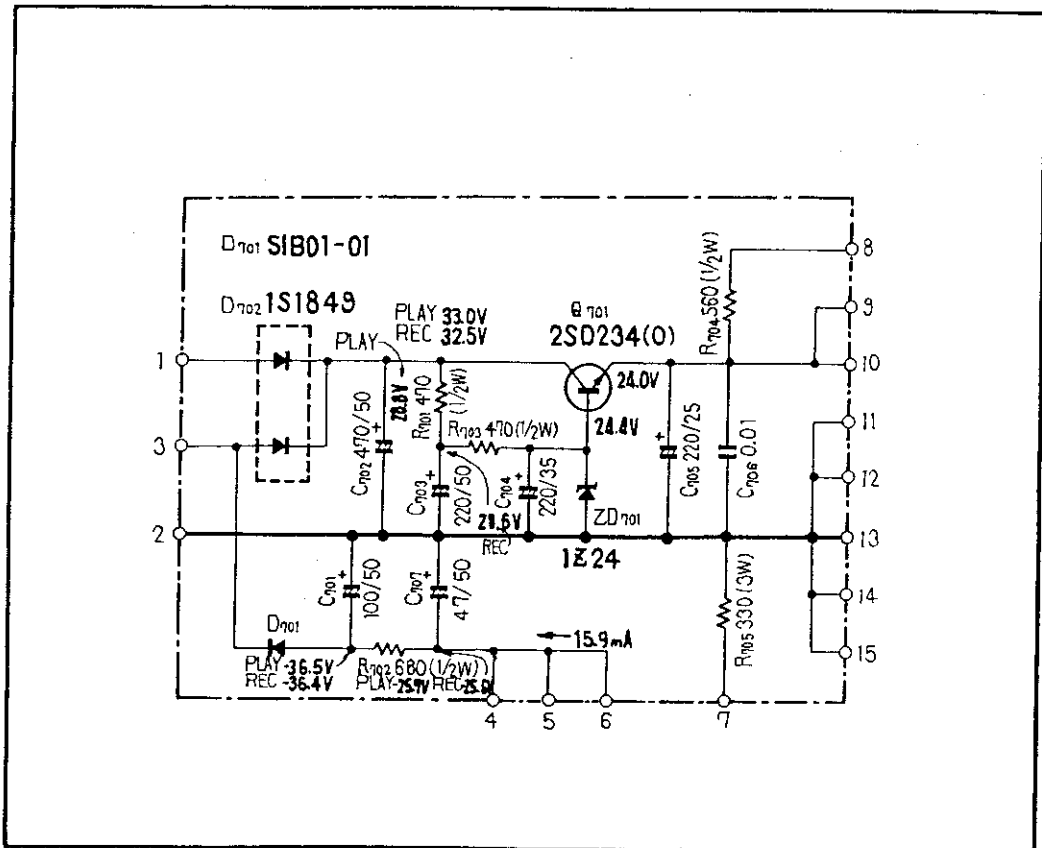

Parts List of Power Supply Assembly (RWR-026)

CAPACITORS

Symbol	Description	Part No.
C701	Electrolytic 100 50V	CEA 101P 50
C702	Electrolytic 470 50V	CEA 471P 50
C703	Electrolytic 220 50V	CEA 221P 50
C704	Electrolytic 220 35V	CEA 221P 35
C705	Electrolytic 220 25V	CEA 221P 25
C706	Ceramic 0.01 50V	CKDYF 103Z 50
C707	Electrolytic 47 50V	CEA 470P 50

RESISTORS

Symbol	Description	Part No.
R705	Metal oxide 330 3W	RS3P 331K
R701	Metal oxide 470 1/2W	RS1/2PSF 471J
R702	Metal oxide 680 1/2W	RS1/2PSF 681J
R703	Metal oxide 470 1/2W	RS1/2PSF 471J
R704	Metal oxide 560 1/2W	RS1/2PSF 561J

SEMICONDUCTORS

Symbol	Description	Part No.
Q701	Transistor 2SD234(0)	
D701	Diode SIB01-01	
D702	Diode 1S1849	
ZD701	Zener diode 1Z24	

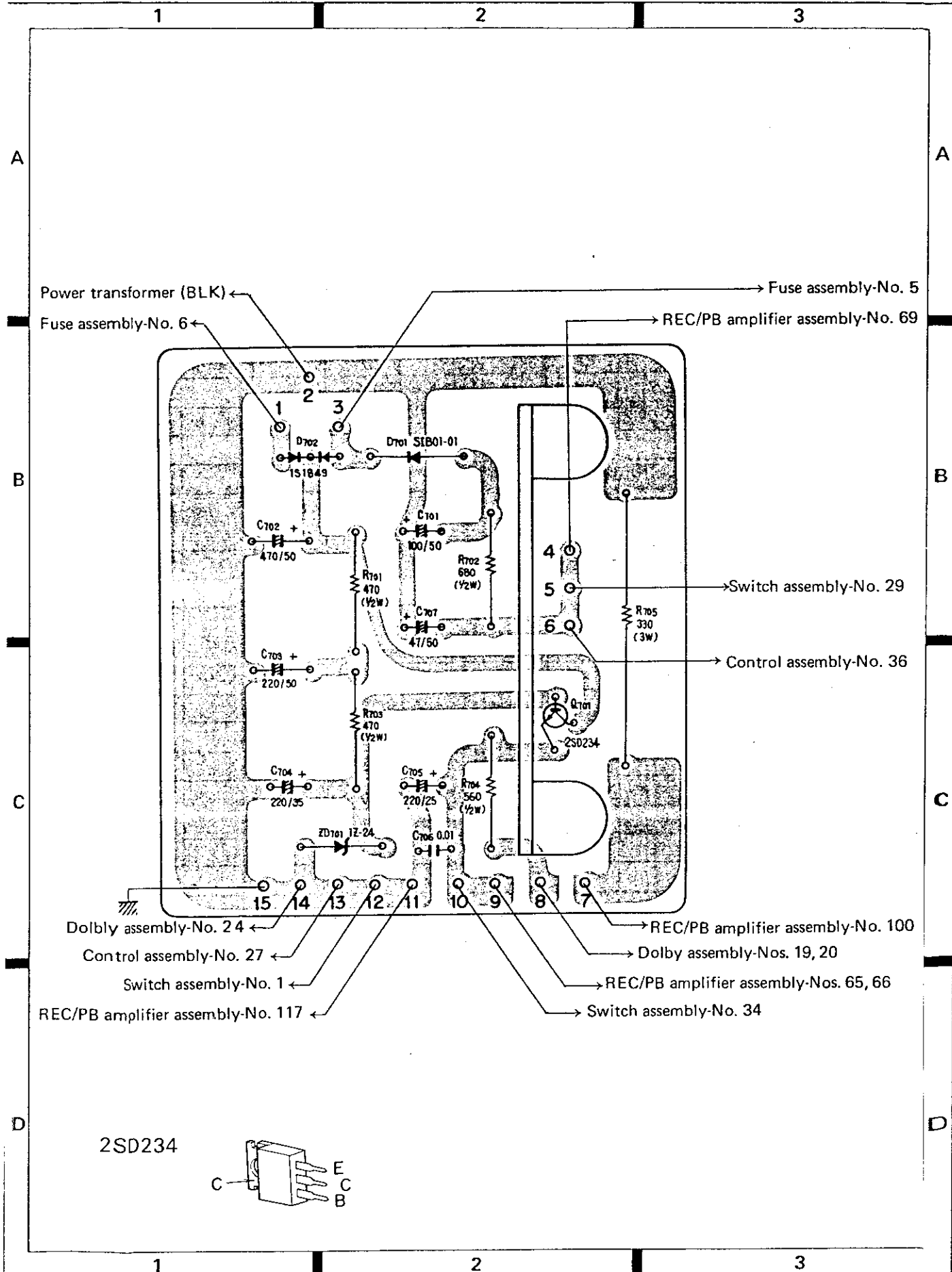

14. EXPLODED VIEW TRANSPORT SECTION

NOTE:
Parts indicated in green type cannot be supplied.

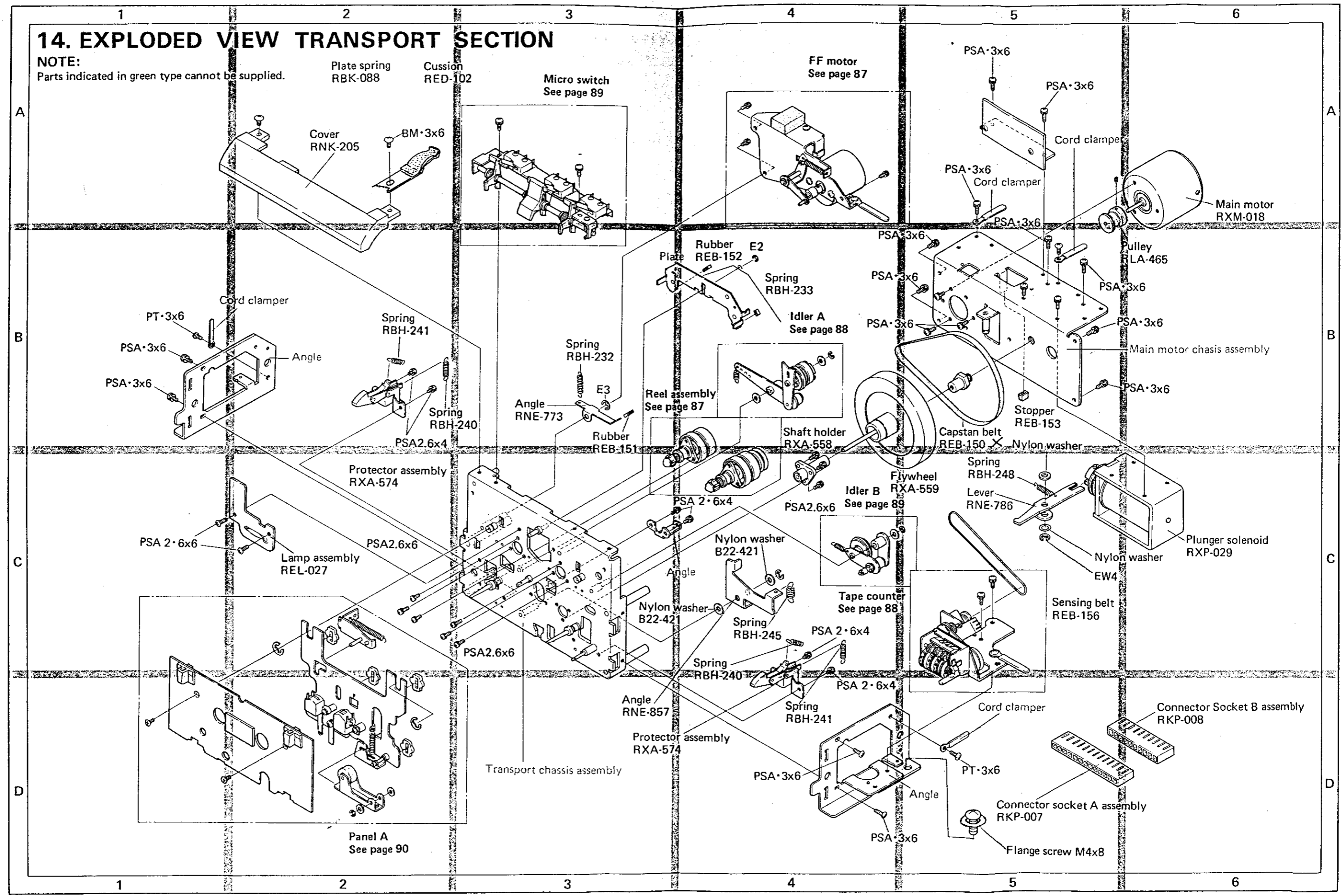

CASSETTE TAPE DECK
CT-F9191
FV, KCU

<ART-13

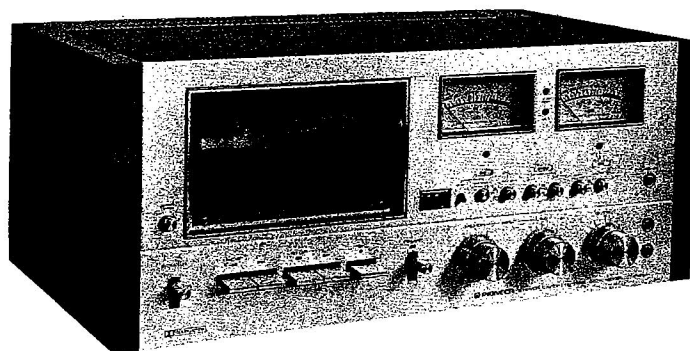

 **PIONEER®**

CONTENTS

1. SPECIFICATIONS	3
2. FRONT PANEL FACILITIES	4
3. CONNECTION DIAGRAM	6
4. BLOCK DIAGRAM	7
5. LEVEL DIAGRAMS	9
6. CIRCUIT DESCRIPTIONS	10
6.1 STOP → PLAY	11
6.2 STOP → REC	12
6.3 STOP → FF	12
6.4 STOP → REW	12
6.5 Memory Play	13
6.6 Pause	14
6.7 Auto Stop	14
6.8 Muting	15
6.9 Unattended Recording	16
6.10 Solenoid Drive Circuit	17
6.11 Pinch Solenoid Timing Circuit	18
6.12 REC Solenoid Timing Circuit	19
6.13 Erase Preventing Circuit	20
7. DISASSEMBLY	
7.1 Bonnet Case	21
7.2 Bottom Plate	21
7.3 Front Panel	22
7.4 Transport Section	22
7.5 Main Motor and FF Motor	23
8. PARTS LOCATIONS	
8.1 Front View	24
8.2 Front View with Panel Removed	25
8.3 Top View (FV type)	26
8.4 Top View (KCU type)	27
8.5 Rear View (FV type)	28
8.6 Rear View (KCU type)	28
8.7 Bottom View	29
9. ELECTRICAL ADJUSTMENTS	
9.1 Head Azimuth	30

13.5	Operating Levers	81
13.6	Control Assembly (RWG-048)	81
13.7	Solenoid (REC)	82
13.8	Plastic Door	82
13.9	Bonnet Case	83
13.10	Bottom Plate	83
13.11	Nomenclature of Screws Washers and Nuts	84
14.	EXPLODED VIEW TRANSPORT SECTION	85
14.1	Reel Assembly	87
14.2	FF Motor	87
14.3	Idler A	88
14.4	Tape Counter	88
14.5	Idler B	89
14.6	Microswitch	89
14.7	Panel A	90
15.	PACKING	91
16.	PART LISTS OF EXPLODED VIEW	92

9.2	Playback Equalizer	30
9.3	Playback Level	30
9.4	OVU Adjustment	31
9.5	Recording Current	31
9.6	Bias Trap	31
9.7	Recording Bias	31
9.8	Recording/Playback Frequency Response	32
9.9	Recording Level	32
9.10	Confirm Limiter Operation	32
9.11	Confirm Peak Indicator Operation	32
9.12	Level Meter Scale Accuracy	32
9.13	Dolby Adjustment	33
10.	MECHANICAL ADJUSTMENTS	
10.1	Wow and Flutter	35
10.2	Pinch Roller Pressure	35
10.3	Tape Speed	35
10.4	Reel Hub Torque	36
10.5	FF/REW Transmission	37
10.6	Record Lever A and B Operation	38
10.7	Replacing Plastic Door	38
10.8	Level Meter Looseness	39
10.9	Microswitches	39
11.	SCHEMATIC DIAGRAMS PC BOARD PATTERNS AND PART LISTS	
11.1	Schematic Diagrams and Miscellaneous Parts	40
11.2	REC/PB Amplifier Assembly (RWF-041)	43
11.3	Indicator Assembly (RWX-081)	51
11.4	Connector Assembly (RWX-084)	51
11.5	Dolby Processer Assembly (RWX-078)	52
11.6	Fuse Assembly (RWX-080)	57
11.7	Control Assembly (RWG-048)	58
11.8	Transistor Assembly (RWX-083)	63
11.9	Switch Assembly (RWS-031)	65
11.10	Power Supply Assembly (RWR-026)	68
11.11	Control Assembly Voltage	70
12.	TIMING CHART	73
13.	EXPLODED VIEW	75
13.1	Front Panel	77
13.2	Panel Stay	78
13.3	Main Chassis	79
13.4	Rear Panel	80

1. SPECIFICATIONS

System	Compact cassette, 2-channel stereo
Motor	Electronically-controlled DC motor (built-in generator) x 1; (4.8cm/s speed drive) DC torque motor x 1; (Fast forward and rewind drive)
Heads	"Ferrite Solid" recording / playback head x 1 Ferrite erasing head x 1
Operation	Solenoid drive, direct switchable and timer play presettable
Fast Winding Time	Approximately 65 seconds (C-60 tape)
Wow and Flutter	No more than 0.07% (WRMS)
Frequency Response	Standard, LH tapes: 25 to 16,000Hz (35 to 13,000Hz \pm 3dB) Chromium dioxide tape: 20 to 17,000Hz (30 to 14,000Hz \pm 3dB)
Signal-to-Noise Ratio	Dolby OFF: More than 52dB Dolby ON: More than 62dB (over 5kHz, standard, LH tapes) (When chromium dioxide tape is used, signal-to-noise ratio is further improved by 4.5dB over 5kHz)
Harmonic Distortion	No more than 1.7% (0dB)
Inputs (Sensitivity/Maximum allowable input/Impedance)	MIC x 2; 0.22mV/100mV/30k Ω , 6mm ϕ jack (Reference MIC impedance; 600 Ω to 30k Ω) LINE x 4 (2-channel stereo, Parallel connection system); 65mV/25V/100k Ω REC/PB x 1; Input & output, 5p jack (DIN standard)
Outputs (Reference level/Maximum level/Load impedance)	LINE x 4; 315mV/530mV/50k Ω (2-channel stereo, Parallel connection system) HEADPHONE x 1; 40mV/65mV/8 Ω With output level controls.
Semiconductors	
Amplifier Section	Transistors x 74 (including FETs x 6), Diodes x 80 (including Zener Diodes x 5, LEDs x 2)
Motor control Section	Transistors x 3, Diodes x 2
Subfunctions	<ul style="list-style-type: none"> • Dolby system (ON-OFF) with indicator lamp • MPX Filter (ON-OFF) • Tape Selector (STD/CrO₂) with indicator lamps Automatic tape selector for CrO₂ tape, and Manual tape selector of independently BIAS/EQ (Ferri-chrome tape available) • Cassette compartment illumination • Mixing control used for MIC and LINE input • Tape counter with rewind Memory switch (ON-OFF) for starting point [REW - STOP/PLAY (REC)] • Recording limiter (ON-OFF) • Wide scale level meter (-40 to +5dB) • Recording Peak level indicator (Lightable level; +5dB) • Level Memory Marker for inputs and output
Power Requirements	AC. 120V, 50 ~ 60Hz (KCU model) AC 110, 120, 130, 220, 240V (Switchable) 50/60Hz (FV model)
Power Consumption	53 watts, Max.
Dimensions	457 (W) x 197 (H) x 315 (D)mm. Max. 17-7/8 x 7-7/8 x 12-3/8 in.
Weight	13.2kg/29 lb (Without package), 15.4kg/34 lb (With package)
Furnished parts	Stereo connecting cord with pin plugs x 2 Head cleaning kit x 1 (Pioneer PP-203) Operating instructions x 1

NOTES:

- Reference tape: standard, LH tapes are DIN no. 45513.
: chrome tape is DIN no. 4513 (CrO₂).
- Reference recording level: meter 0dB level (equivalent to 160 pwb/mm)
- Reference signal: 333Hz.
- Wow & Flutter: at 3kHz weighted rms.
- Frequency response: measured at -20dB level, DOLBY OFF, MPX Filter OFF. Level deviation is \pm 6dB without indication.
- Signal-to-Noise ratio: measured at +4dB level (equivalent to 250 pwb/mm with weighted IEC A curve, MPX Filter OFF.
- Sensitivity: Input level (mV) for reference recording measured with input (recording) level control set at maximum position.
- Maximum allowable input level: measured at the point where the output signal wave is clipped while gradually turning the input level control.
- Reference output level: meter 0dB level.
- Maximum output (playback) level: Output level to reference recording level, measured with output (playback) level control set at maximum position.

NOTE:

Specifications and the design subject to possible modification without notice due to improvements.

2. FRONT PANEL FACILITIES

POWER SWITCH

Power is supplied when set to ON, at which time the level meter lamps and internal illuminating lamp light.

DOOR OPEN BUTTON

Press to open the cassette door. Close the cassette door by gently sliding it downward by hand.

CASSETTE DOOR

Keep door closed to protect the transport and head assembly from dust.

REC INDICATOR

Lights red during recording.

NOTE:

Be sure to confirm REC indicator lighting before proceeding to record.

LEVEL METERS

Display input level during recording and output level during playback.

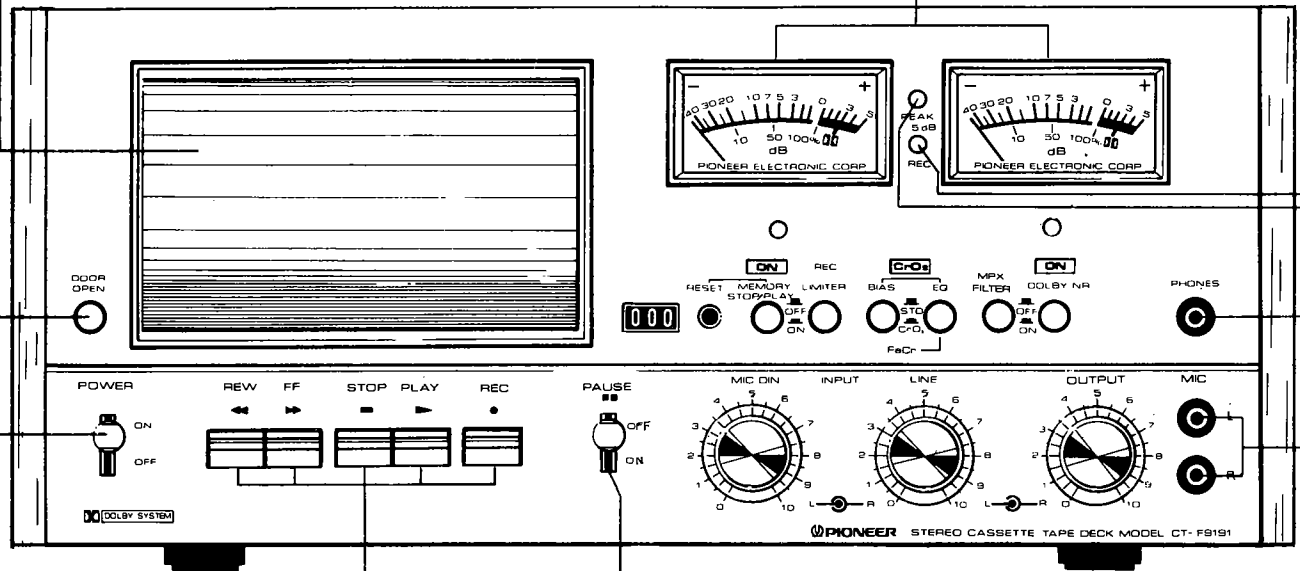

OPERATING LEVERS

- REW** ◀◀ (Rewind): Press downward to rewind tape. (Tape travels from right to left.)
- FF** ▶▶ (Fast Forward): Press downward for tape fast forward. (Tape travels from left to right.)
- STOP** ■: Press downward to stop tape motion; this will also release other operating levers.
- PLAY** ▶: Press downward to play tape. To record, press simultaneously with the REC lever. (Tape travels from left to right.)
- REC** ● (Record): Press downward simultaneously with the PLAY lever to perform recording.

NOTES:

1. Avoid simultaneously depressing two or more levers (except for the PLAY and REC levers when recording).
2. With the CT-F9191, it is not necessary to depress the STOP lever when switching between modes.

PAUSE SWITCH

Set to ON to temporarily stop the tape motion during record or playback. Return it to OFF to resume tape motion. This switch does not function during fast forward or rewind.

MIC JACKS

Microphone recording input jacks. Independent left (L) and right (R) channel jacks are provided.

PHONES JACK

Stereo headphones can be plugged into this jack for private listening or monitoring a recording.

PEAK +5dB INDICATOR

Lights when +5dB over level is reached during recording. When recording, adjust MIC/DIN or LINE controls so that it does not light continuously.

3. CONNECTION DIAGRAM

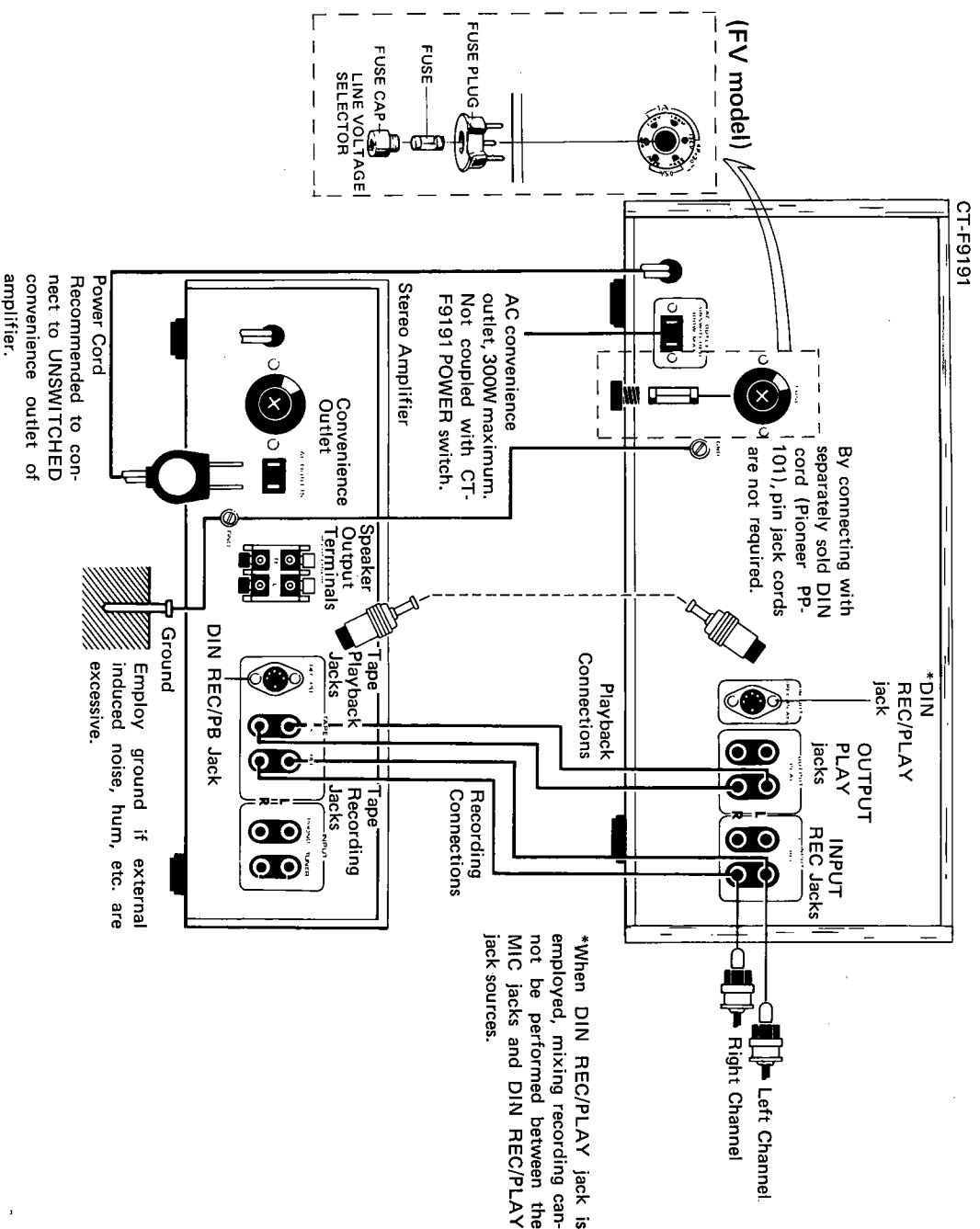

MEMORY INDICATOR LAMP

Lights when MEMORY button is depressed.

COUNTER RESET BUTTON

Depressing button resets counter indication to 000.

TAPE COUNTER

Indicates tape running position.

MPX FILTER BUTTON

FM stereo broadcast pilot signal (19KHz) is blocked when button is set to ON (depressed). Use only for FM Dolby recording and set to OFF (undeprressed) at other times.

DOLBY INDICATOR LAMP

Lights when DOLBY NR button is depressed.

DOLBY NR BUTTON

Depress for Dolby recording and for playback of Dolby recorded tape.

MEMORY BUTTON

When set to ON (depressed), the tape running position during record or playback corresponding to the 000 counter indication is registered. Memory play and memory stop functions can then be performed.

REC LIMITER BUTTON

When recording sources with large level variations which cause over levels and render control adjustment difficult, depress this button for easier recording.

CrO₂ INDICATOR LAMP

Lights to indicate chromium dioxide tape. Also lights when cassette has not been installed.

MEMORY MARKER DIALS

Set these outer rings to mark preferred control positions.

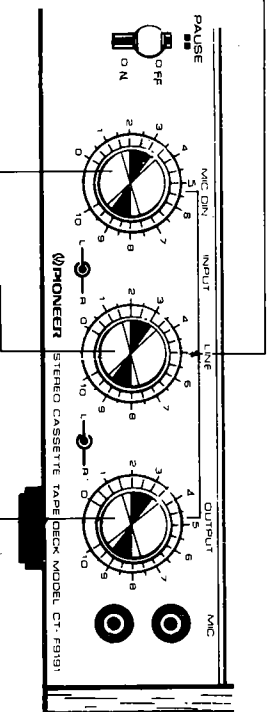

MIC/DIN RECORDING LEVEL CONTROLS

Adjust the input signal from the front panel MIC jacks or rear panel DIN REC/PLAY jack. The outer knob controls the right (R) channel, while the inner knob controls the left (L) channel.

LINE RECORDING LEVEL CONTROLS

Adjust input signal from the INPUT (REC) jacks. The outer knob controls the right (R) channel while the inner knob controls the left (L) channel.

EQ (EQUALIZATION) SELECTOR BUTTON

Employ according to tape. Depress for chrome or ferrichrome tape. Set to OFF (undeprressed) to play chrome tape recorded to earlier specifications (120µs).

BIAS SELECTOR BUTTON

Employ according to tape. Depress when using chrome tape.

NOTE:

If a chrome tape is provided with index holes, EQ and BIAS selection becomes automatic. It is not necessary in this case to depress the EQ and BIAS buttons.

OUTPUT LEVEL CONTROLS

Adjust the output signal level during playback. The outer knob controls the right (R) channel while the inner knob controls the left (L) channel.

NOTE:

LEVEL controls can be employed for adjusting R and L channels independently. If there is a difference in input or output levels, turn one of the controls so that the levels become equal.

INPUT & OUTPUT JACKS

2 sets each of INPUT and OUTPUT jacks, which are connected in parallel, plus a DIN REC/PLAY jack are provided on the CT-F9191.

INPUT Jack Connections

Connect one set of INPUT jacks to the tape recording output jacks of a stereo amplifier. Since the INPUT jacks are connected in parallel, the recording input jacks of an additional tape deck (open reel or cassette) can be connected to one set to allow simultaneous recording of the same program source together with the CT-F9191.

OUTPUT Jack Connections

Connect one set of OUTPUT jacks to the TAPE PB jacks of a stereo amplifier. If a second tape

deck is available, its recording input jacks can be connected with the other set of OUTPUT jacks. This will allow a tape played on the CT-F9191 to be duplicated onto another tape by the second deck.

DIN REC/PLAY Jack

By connecting this jack to a program source, mixing recording can be performed with a program source connected to the INPUT (REC) jacks. Adjust the recording level of a source connected to the DIN REC/PLAY jack with the MIC/DIN controls.

If microphones are connected to MIC jacks, recording cannot be performed from source connected to this jack.

5. LEVEL DIAGRAMS

REC

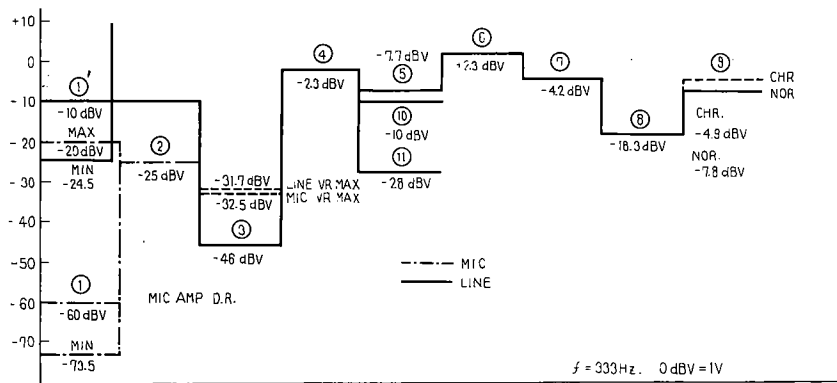
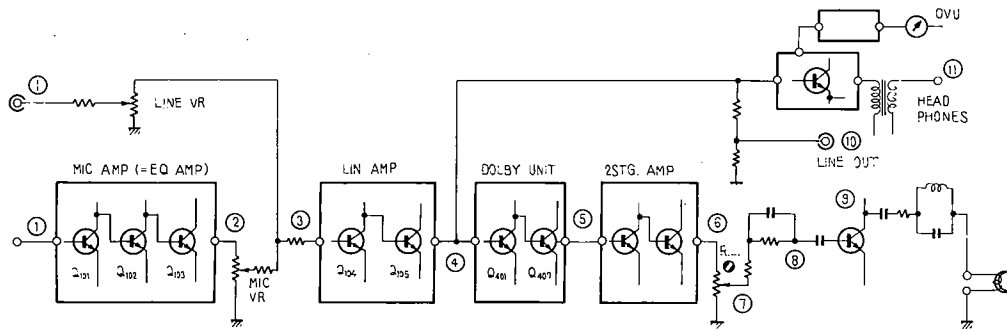

P.B.

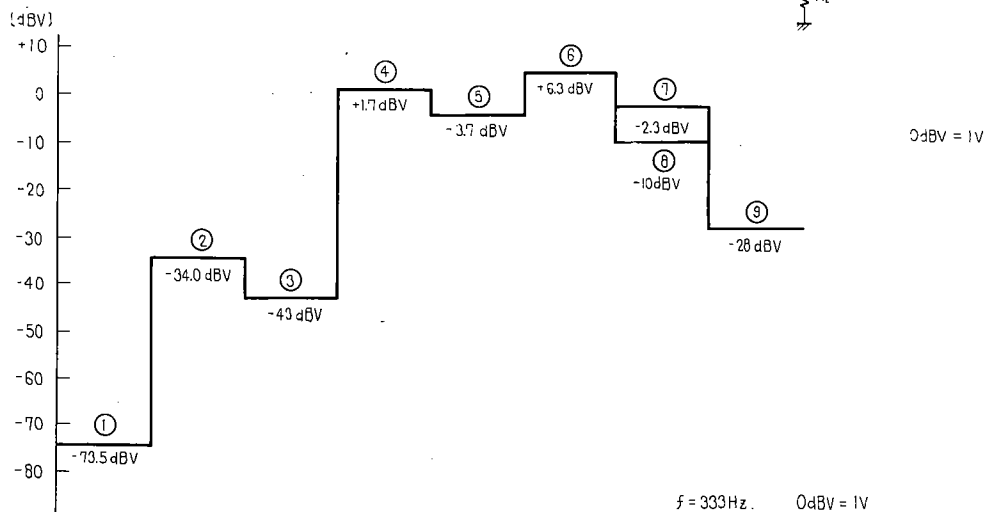
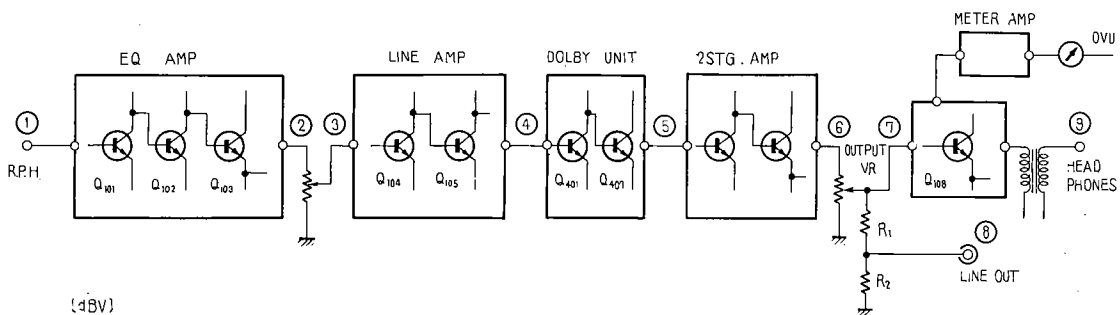

6. CIRCUIT DESCRIPTIONS

This circuit description consists of Sections 6.1 — 6.13.

Use care in regard to the following symbols and expressions which appear in the text.

+B₁, +B₂, +B₃: Indicate fixed voltage lines as illustrated in Fig. 1.

S_{12-3,4}: Appears as a single switch in the schematic, but actually two identical switches are employed in parallel.

Route: Refers to current path of +B, etc.

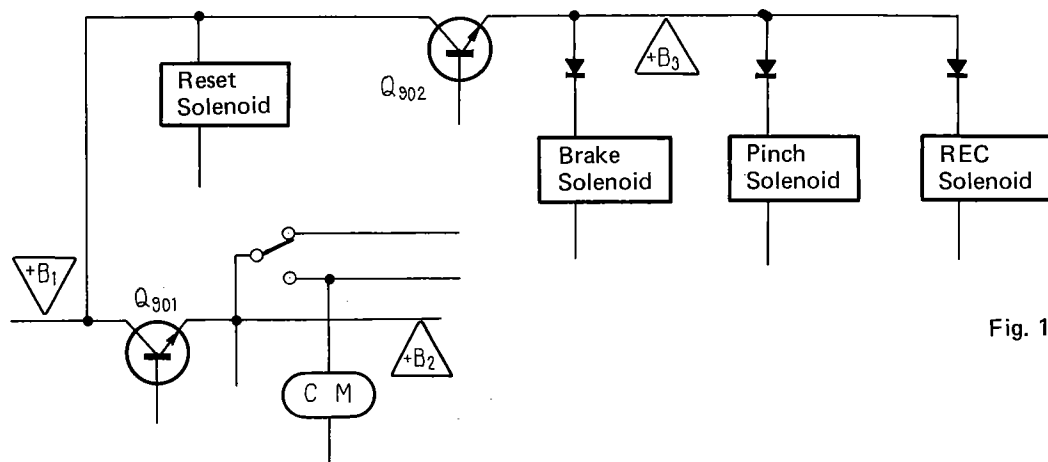

Fig. 1

6.1 STOP-PLAY (Fig. 2)

1. With the Power switch ON and a cassette installed, S_{14} is switched ON and the main motor (CM) rotates.
2. Capacitor C_{814} charging current is obtained from $+B_2$ by two routes: $C_{814} - D_{814} - R_{829} - Q_{809}$ base and $C_{814} - D_{815} - R_{831} - Q_{810}$ base. Q_{809} and Q_{810} are switched ON.
3. C_{814} charging is completed in approximately 2 seconds. Although Q_{809} and Q_{810} would be expected to switch OFF, since R_{829} (680Ω) is less than R_{831} ($1.5k\Omega$), Q_{809} remains ON and Q_{802} switches OFF. Also Q_{810} switches OFF and Q_{803} ON.

4. With Q_{810} in the OFF state, its collector potential rises and base potential is applied to Q_{809} by the route $+B_2 - R_{834} - R_{833}$ to maintain Q_{809} in the ON condition.

Normally: Q_{810} is OFF and Q_{803} ON

Q_{809} is ON and Q_{802} OFF

5. When the Play lever is pressed at this point, S_{10-4} is switched ON and current flows from $+B_3$ by the route $D_{902} - \text{pinch solenoid} - Q_{804} - S_{10-4} - S_{12-3,4} - S_{11-4} - Q_{803}$ to operate the pinch solenoid and tape running starts.

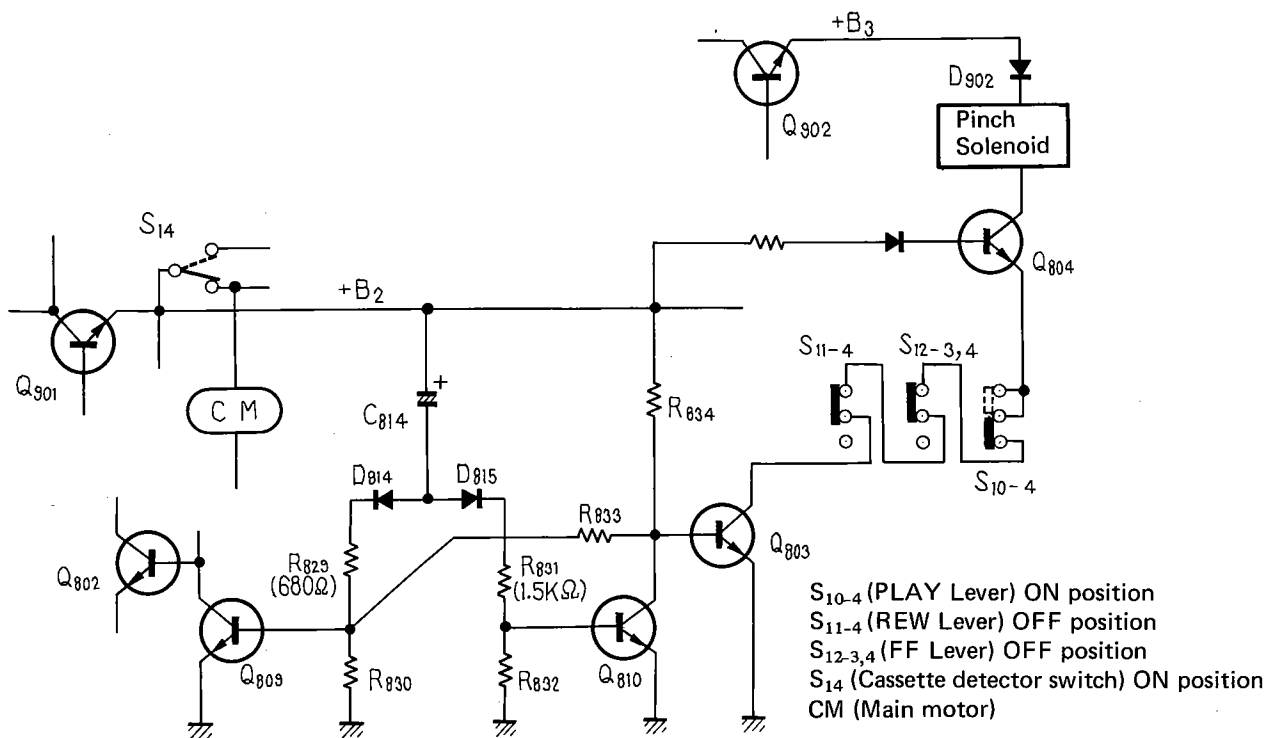
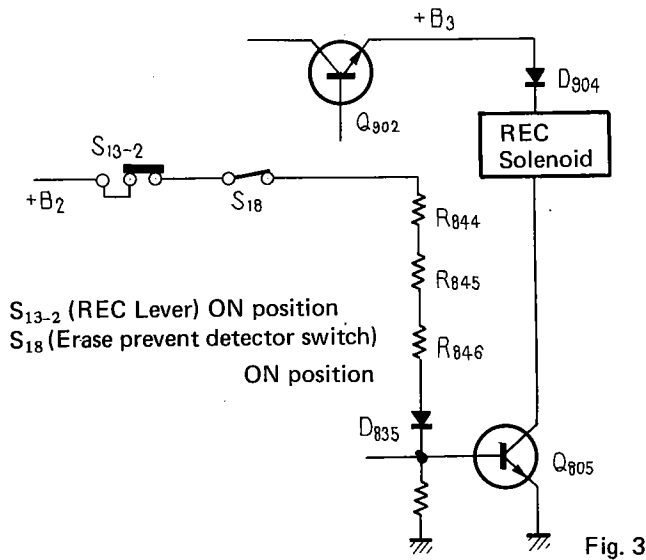

Fig. 2

6.2 STOP – REC (Fig. 3)

1. Play and REC levers are pressed simultaneously. Although the pinch solenoid operation is the same as described in Section 6.1, the REC lever also switches on S_{13-2} and current flows by the route $+B_3 - D_{904} - \text{REC solenoid} - Q_{805}$ to operate the REC solenoid.
2. The REC solenoid operates to switch the record/play amplifier assembly (RWF-041) to the record mode.

* S_{18} is an accidental erase preventing switch. If the erase preventing tab of the installed cassette is broken off, S_{18} is not closed and the REC solenoid does not operate.



S_{13-2} (REC Lever) ON position
 S_{18} (Erase prevent detector switch) ON position

6.3 STOP – FF (Fig. 4)

1. Pressing the FF lever (S_{12}) causes current from $+B_3$ to flow by the route $D_{901} - \text{brake solenoid} - D_{806} - S_{12-3,4} - S_{11-4} - Q_{803}$. The brake solenoid operates to release the brake.
2. Current is applied to the FF (REW) motor RM from $+B_2$ by the route $S_{11-2} - S_{12-1} - \text{RM} - D_{803} - S_{12-3,4} - S_{11-4} - Q_{803}$ and the tape fast forward is performed.

6.4 STOP – REW (Fig. 4)

1. When the REW lever is pressed, current flows from $+B_3$ by the route $D_{901} - \text{brake solenoid} - D_{805} - S_{11-4} - Q_{803}$ and the brake solenoid operates to release the brake.
2. Current is applied to the REW (FF) motor RM from $+B_2$ by the route $S_{11-2} - \text{RM} - D_{802} - S_{11-4} - Q_{803}$ and the tape rewind is performed.

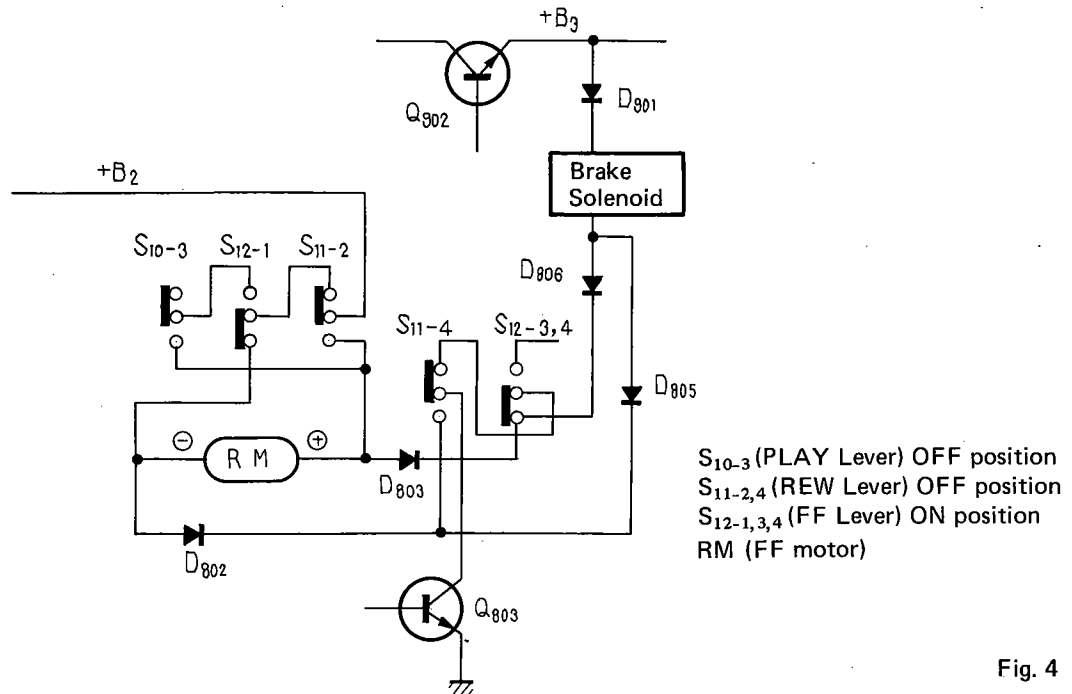

S_{10-3} (PLAY Lever) OFF position
 $S_{11-2,4}$ (REW Lever) OFF position
 $S_{12-1,3,4}$ (FF Lever) ON position
 RM (FF motor)

3.5 MEMORY PLAY (Fig. 5)

1. When the memory switch $S_{9-3,4}$ is depressed and the REW lever pressed, C_{817} instantaneously charges by the route $+B_2 - S_{9-4} - S_{11-1} - C_{817}$.
2. Afterwards, pressing the Play lever sets S_{11-1} off and S_{10-1} on. C_{817} is discharged by the route $C_{817} - D_{817} - S_{10-1} - S_{12-2} - R_{835} - Q_{810}$ and Q_{810} is switched ON.
3. With Q_{810} in the ON state, its collector potential drops, causing Q_{809} to switch OFF and Q_{802} ON. Current from $+B_2$ is applied to the reel motor by the route $S_{11-2} - S_{12-1} - S_{10-3} - RM - D_{802} - Q_{802}$ and rewind is performed.
4. For this reason, even if S_{11-4} is returned to the off position, the route $+B_3 - \text{brake solenoid} - D_{805} - Q_{802}$ is formed and rewind operation continues.

5. The tape rewinds to "999" on the counter and S_{16} is closed. Q_{809} base current is obtained from $+B_2$ by the route $S_{9-3} - S_{16} - C_{812} - S_{11-3} - D_{813} - R_{823} - Q_{809}$. Q_{809} is switched ON, Q_{802} OFF and motor RM stops, completing rewind operation.
6. When Q_{809} switches ON, its collector potential drops, turning Q_{810} OFF and Q_{803} ON. This causes current from $+B_3$ to flow by the route $D_{902} - \text{pinch solenoid} - Q_{804} - S_{10-4} - S_{12-3,4} - S_{11-4} - Q_{803}$. The pinch solenoid operates and play begins.

Memory Stop

In this mode, when the tape counter reaches "999" S_{16} is switched on. Current flows from $+B_2$ via $S_{9-3} - S_{16} - C_{812} - S_{11-3} - D_{812} - R_{813} - Q_{801}$. The reset solenoid then functions to stop all operations.

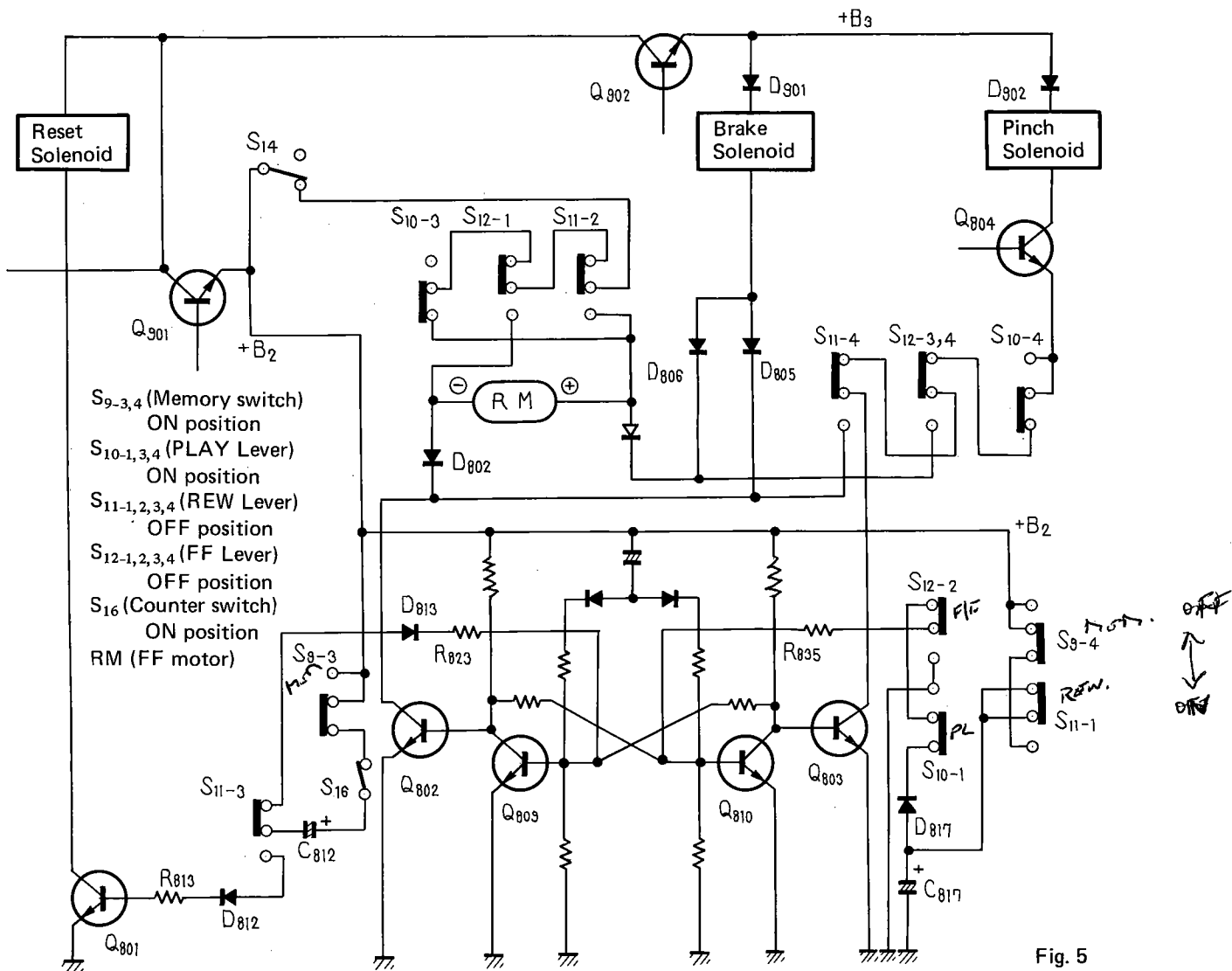

Fig. 5

6.6 PAUSE (Figs. 6, 8)

1. During playing and recording, base current from $+B_2$ flows by the route $R_{842} - D_{831} - Q_{804}$ and Q_{804} is switched ON.
2. When the Pause switch S_{17} is set to ON, $+B_2$ current flows through $R_{842} - S_{17} - \text{ground}$ and Q_{804} base current ceases. Q_{804} switches OFF, the pinch solenoid resets and tape running stops.
3. If the Pause switch is set to ON during recording, since the REC solenoid operates from a different circuit, the recording circuit is not affected.
4. In modes other than record and play, C_{822} is charged (reverse bias with respect to Q_{811}) and Q_{811} is switched OFF. When the Play and Rec levers are pressed, C_{822} is discharged through R_{858} or R_{859} and during this approximately 100msec interval, Q_{811} continues in the OFF condition.

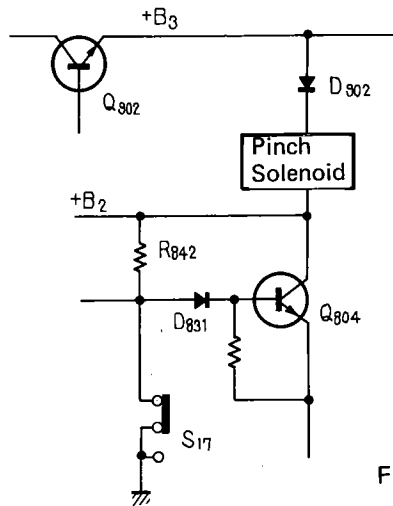

Fig. 6

S_{17} (Pause Lever) ON position

6.7 AUTO STOP (Fig. 7)

1. S_{15} repeatedly switches ON-OFF while the tape runs, producing a type of AC signal. This signal also switches Q_{807} ON - OFF.
2. When tape running stops, S_{15} stops in either the ON or OFF position and Q_{807} is switched OFF.
3. With Q_{807} OFF, C_{810} is charged by the route $+B_2 - R_{815} - D_{809} - C_{810}$. Approximately 2 to 3 seconds later Q_{808} switches ON.
4. Accompanying this, current flows from $+B_2$ to Q_{806} base - $R_{806} - Q_{808} - R_{819}$ and Q_{806} also switches ON.
5. Q_{806} collector current flows through $+B_2 - Q_{806} - R_{803} - C_{805} - Q_{801}$ base and charges C_{805} . In the interval until the charging is completed, Q_{801} is switched ON, the reset solenoid operates and Stop condition is obtained. Q_{801} switches OFF after C_{805} is completely charged.

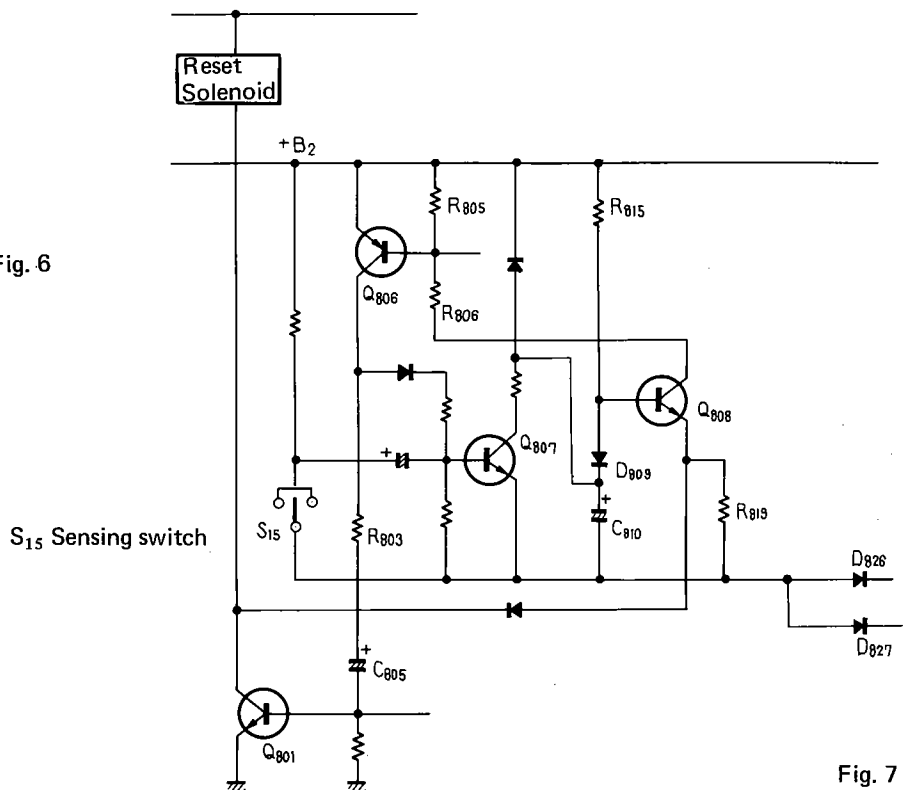

Fig. 7

6.8 MUTING (Fig. 8)

This function serves to suppress output noise during fast forwarding and rewinding, record to stop switching, and power switch operation.

1. During Stop, FF and Rewind, Q_{811} is reverse biased and OFF. Q_{118} and Q_{218} are switched ON, shorting the output and performing the muting function.
2. Pressing the Play lever causes base current to flow to Q_{811} via $+B_2 - Q_{811} - D_{825} - R_{858} - Q_{804}$ and Q_{811} is switched ON. When the REC lever is pressed, the route becomes $+B_2 - Q_{811} - D_{824} - R_{859} - Q_{805}$ and Q_{811} is switched ON.
3. With Q_{811} ON, the bases of Q_{118} and Q_{218} in the record/play amplifier assembly (RWF-041) become reverse biased, switching them OFF. Muting is therefore released and the output signals are obtained.

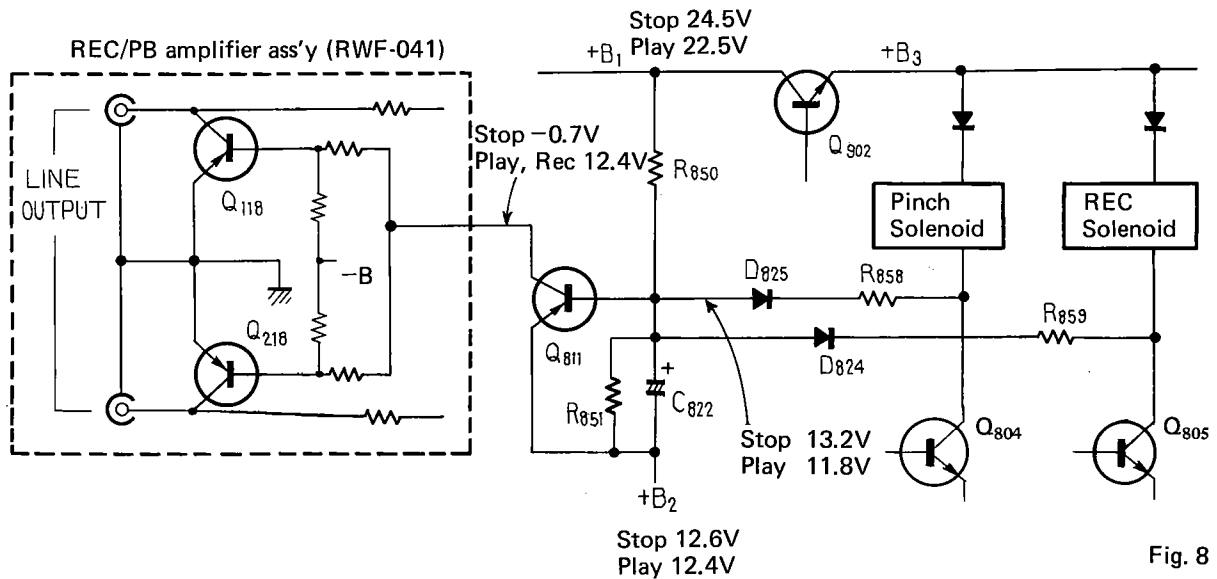

Fig. 8

6.9 UNATTENDED RECORDING (Fig. 9)

A timer can be employed to turn on the power at a desired time to perform unattended recording. The Play and REC levers are pressed and the Power switch set to ON after setting the timer.

1. When power is supplied, C_{814} charging begins as described in Section 6.1. Q_{810} are switched ON during this interval, while Q_{803} switches OFF, the pinch solenoid does not operate. Neither does the REC solenoid operate, since the $+B_2$ of Q_{805} is coupled through $S_{13-2} - S_{18} - R_{834-6} - D_{834} - Q_{810}$.
2. Q_{810} switches OFF when C_{814} charging is completed, after which Q_{803} and Q_{805} switch ON. Since Q_{805} switches ON prior to Q_{803} , the REC and pinch solenoids operate in succession.

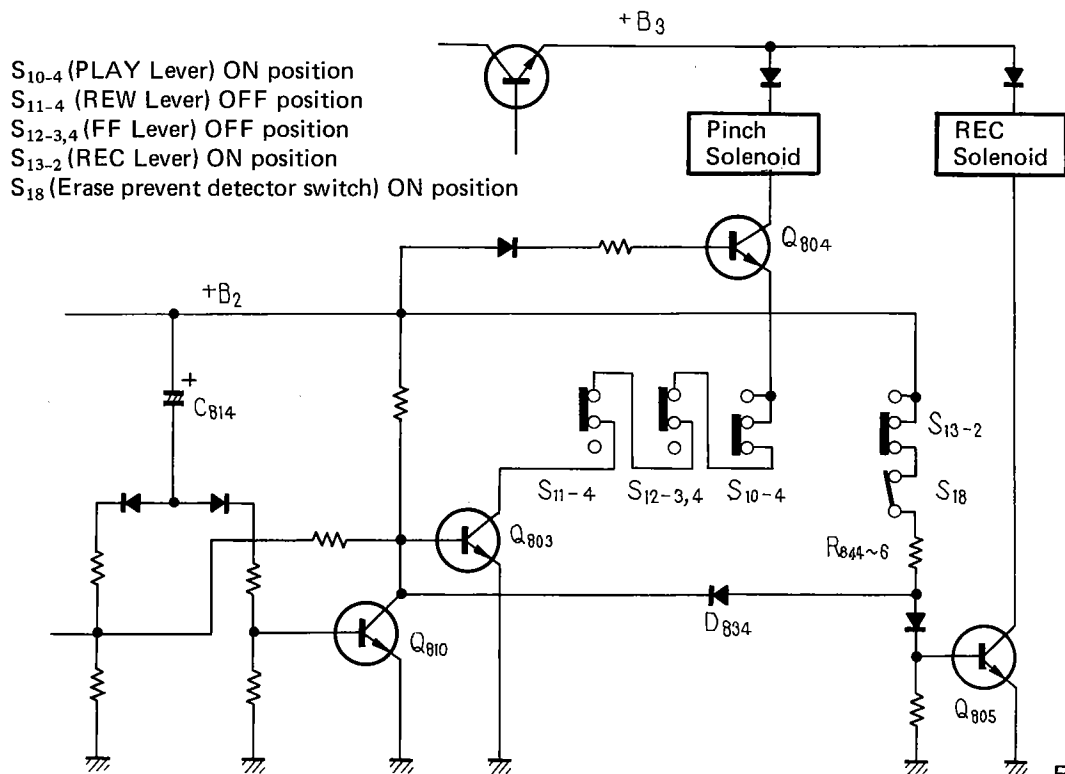

Fig. 9

6.10 SOLENOID DRIVE CIRCUIT (Fig. 10)

Current increases during solenoid operation to raise its attractive force. After operation, the current returns to normal in order to prevent solenoid heating.

1. With the Play lever pressed, in the operation described in Section 6.1, current flows via +B₃ — D₉₀₂ — pinch solenoid — Q₈₀₄ — S₁₀₋₄ — S_{12-3,4} — S₁₁₋₄ — Q₈₀₃ and the pinch solenoid operates.
2. C₈₂₄ is charged by the route +B₁ — Q₈₁₂ — R₈₅₂ — D₈₂₂ — C₈₂₄. This charging current becomes the Q₈₁₂ base current, switching Q₈₁₂ ON.
3. As Q₈₁₂ switches ON, the base potential of Q₉₀₂ rises and Q₉₀₂ collector current increases. In this manner, large current flow is obtained only during solenoid operation.

4. C₈₂₄ charging is completed approximately 1 second after solenoid operation. Q₈₁₂ base current then ceases and Q₈₁₂ switches OFF.
5. In the OFF state, Q₈₁₂ base potential is maintained by ZD₈₀₂. Both the collector current and the current flowing through the solenoid are therefore returned to normal to avoid heating.
6. In addition to the pinch solenoid, the brake and REC solenoids also operate on the same principle.

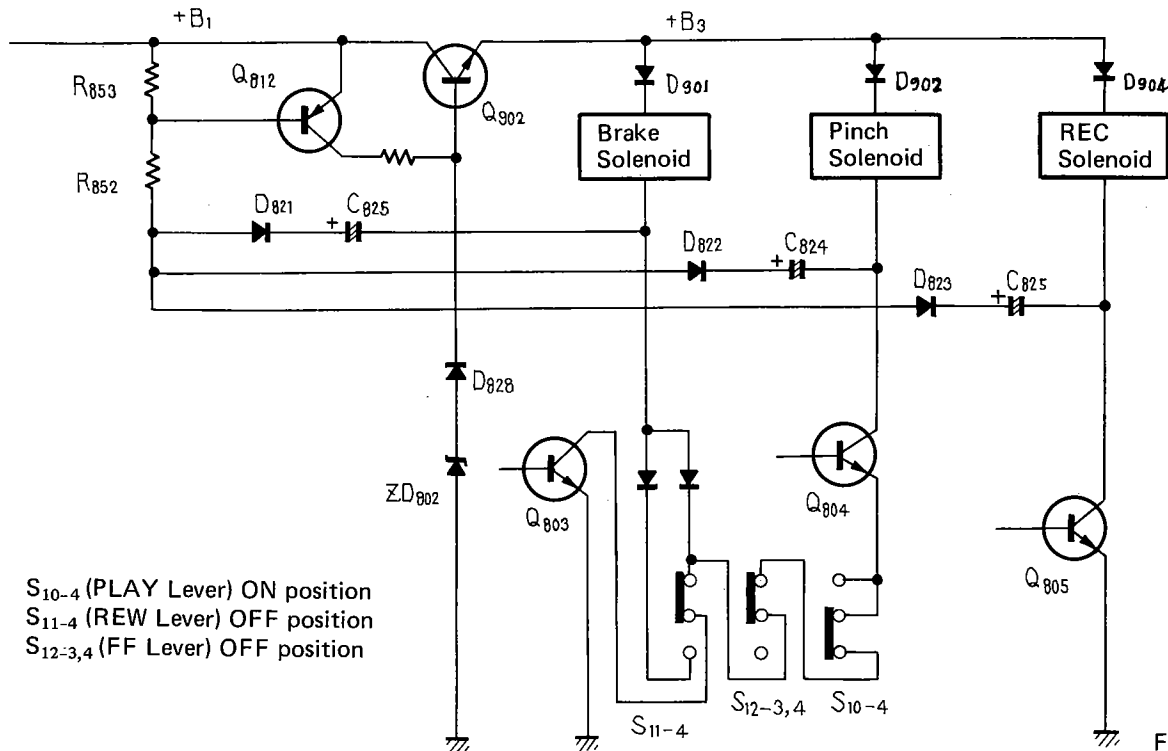

Fig. 10

6.11 PINCH SOLENOID TIMING CIRCUIT (Fig. 11)

This circuit functions to prevent tape damage or slackening when the set is switched directly from FF or REW to Play.

1. As described in Section 6.1, during fast forwarding, current flows via $+B_3 - D_{901} -$ brake solenoid $- D_{806} - S_{12-3,4} - S_{11-4} - Q_{803}$, releasing the brake and motor RM rotates.
2. C_{819} is charged at this time by the route $+B_2 - R_{841} - C_{819} - D_{829} - D_{806} - S_{12-3,4} - S_{11-4} - Q_{803}$.
3. When the Play lever is pressed during FF or REW operation, Q_{804} emitter approaches ground potential, while one side of C_{819} is temporarily brought below ground potential to a minus value.
4. For this reason, current flows in the route $+B_2 - R_{842} - D_{830} - C_{819}$, Q_{804} base current ceases and Q_{804} is switched OFF. With Q_{804} OFF, even if the Play lever is pressed, since the pinch solenoid does not operate, tape running stops.
5. About 0.5 second after C_{819} discharges, Q_{804} base current flows and Q_{804} switches ON. The pinch solenoid operates and play begins.

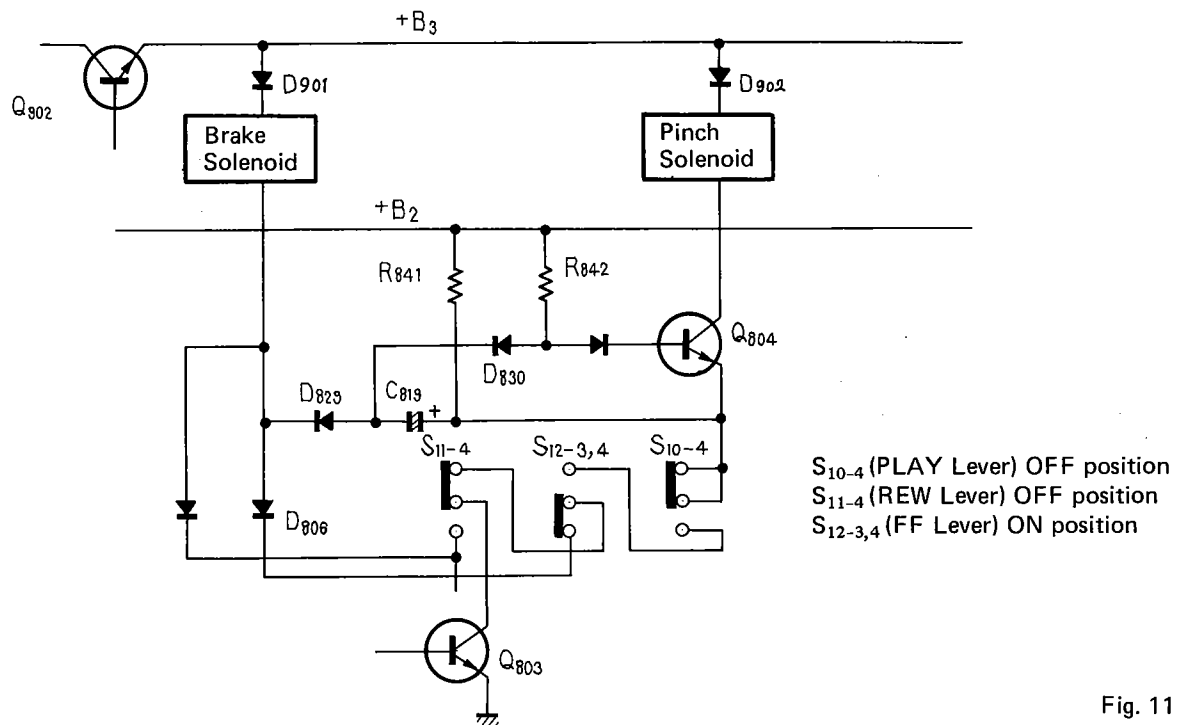

Fig. 11

6.12 REC SOLENOID TIMING CIRCUIT
(Fig. 12)

Incorrect REC solenoid return timing can cause noise to be recorded onto the tape when switching from REC to Stop, Play, FF or REW. This circuit prevents such noise by setting the oscillator circuit OFF before returning the REC solenoid.

1. As described in Section 6.2, the REC solenoid operates during recording by the route $+B_3 - D_{904} - \text{REC solenoid} - Q_{805}$. At the same time, $+B_2$ charges C_{820} via $S_{13-2}, S_{18} - R_{844} - C_{820}$.
2. When Stop, FF or REW lever is pressed during recording, S_{13-1} and S_{10-2} are switched OFF and $+B$ to the oscillator circuit stops. Although S_{13-2} is also switched OFF, since C_{820} is discharged via $C_{820} - R_{845} - R_{846} - D_{835} - Q_{805}$, Q_{805} remains in the ON condition for about 10ms during this discharge time.
3. The oscillator circuit is thus stopped about 10ms before the REC solenoid operates.

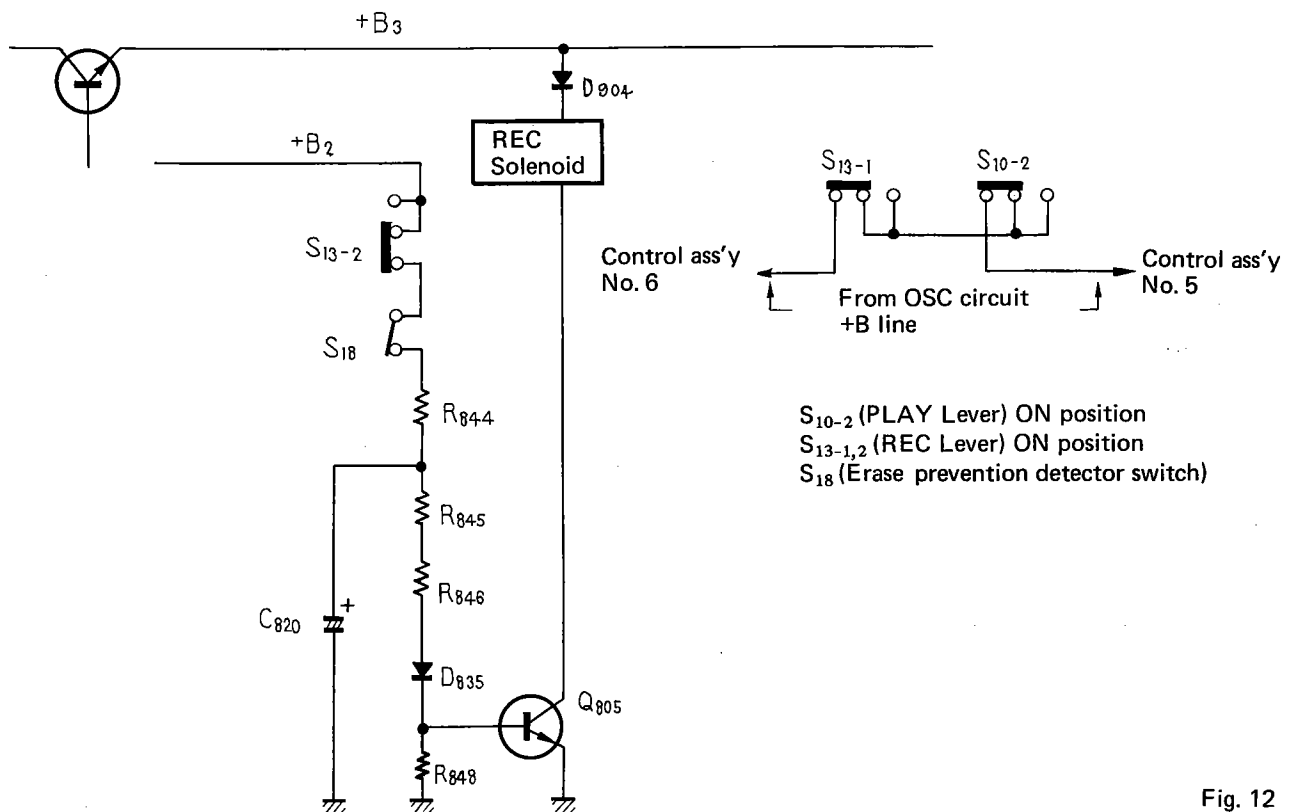

Fig. 12

6.13 ERASE PREVENTING CIRCUIT (Fig. 13)

This circuit prevents the record mode from engaging in case the FF (REW) lever is pressed together with the REC and Play levers.

1. When the REC lever is pressed, Q_{805} is switched ON via $+B_2 - S_{13-2} - S_{18} - R_{844} - R_{845} - R_{846} - D_{835} - Q_{805}$ and the REC solenoid operates.
2. If the FF lever is also pressed at this time, current will flow through $+B_2 - S_{13-2} - S_{18} - R_{844} - R_{845} - D_{832} - S_{12-3,4} - S_{11-4} - Q_{803} - Q_{805}$ is switched OFF, the REC solenoid returns, and FF operation only is performed.
3. In this mode, since the REC solenoid is not operating, the recording, bias and oscillator circuits also do not operate.

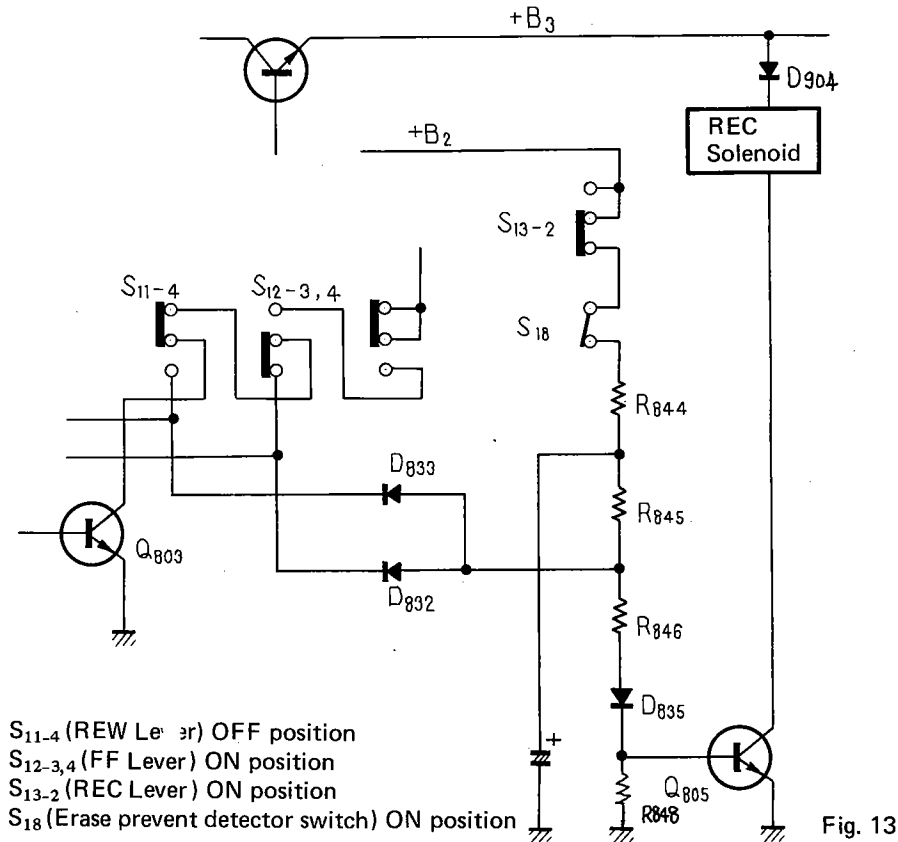

Fig. 13

7. DISASSEMBLY

7.1 BONNET CASE

- Remove 10 screws securing the bonnet case.

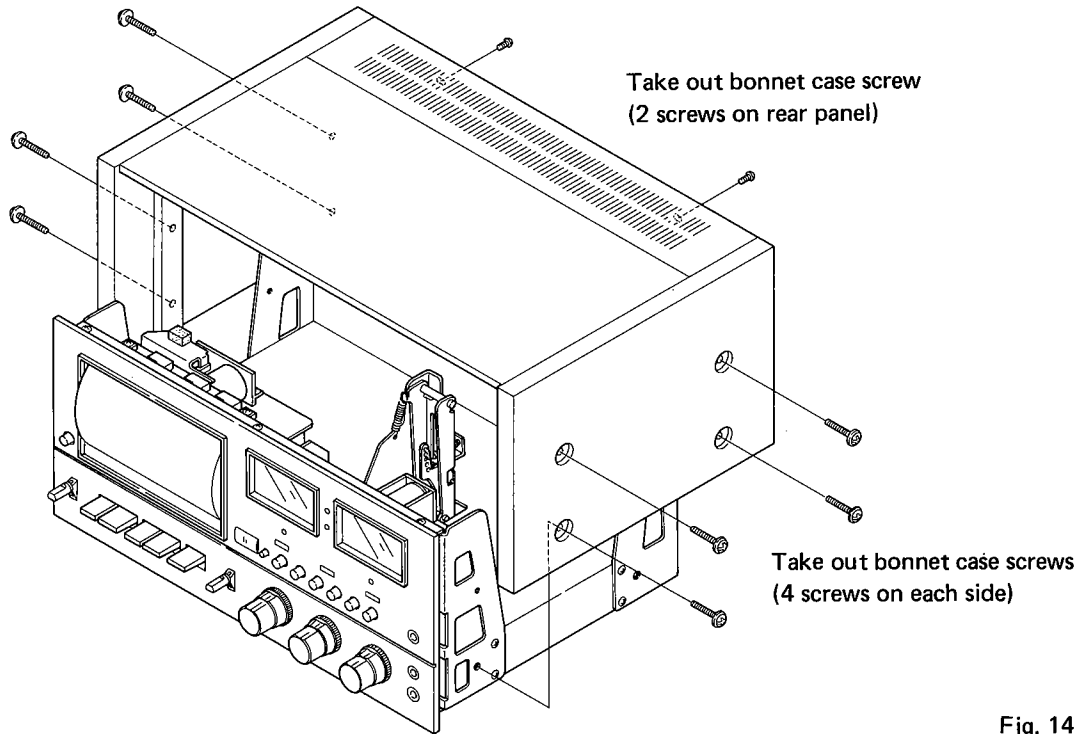

Fig. 14

7.2 BOTTOM PLATE

- Take out 7 screws securing the bottom plate.

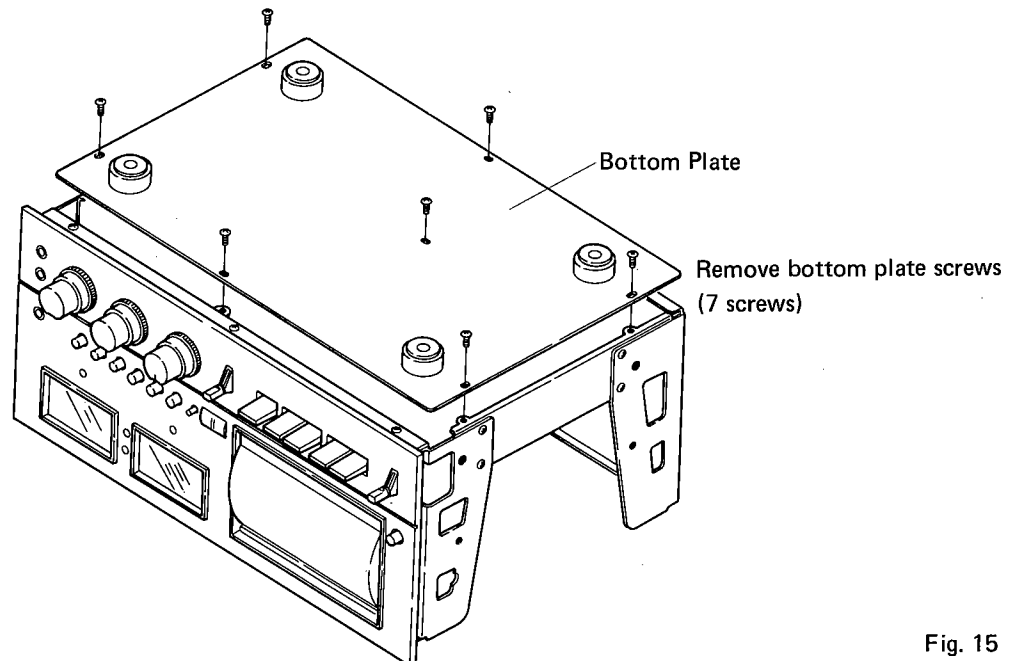

Fig. 15

7.3 FRONT PANEL

Pull off control knobs.
Remove 6 screws securing the front panel.

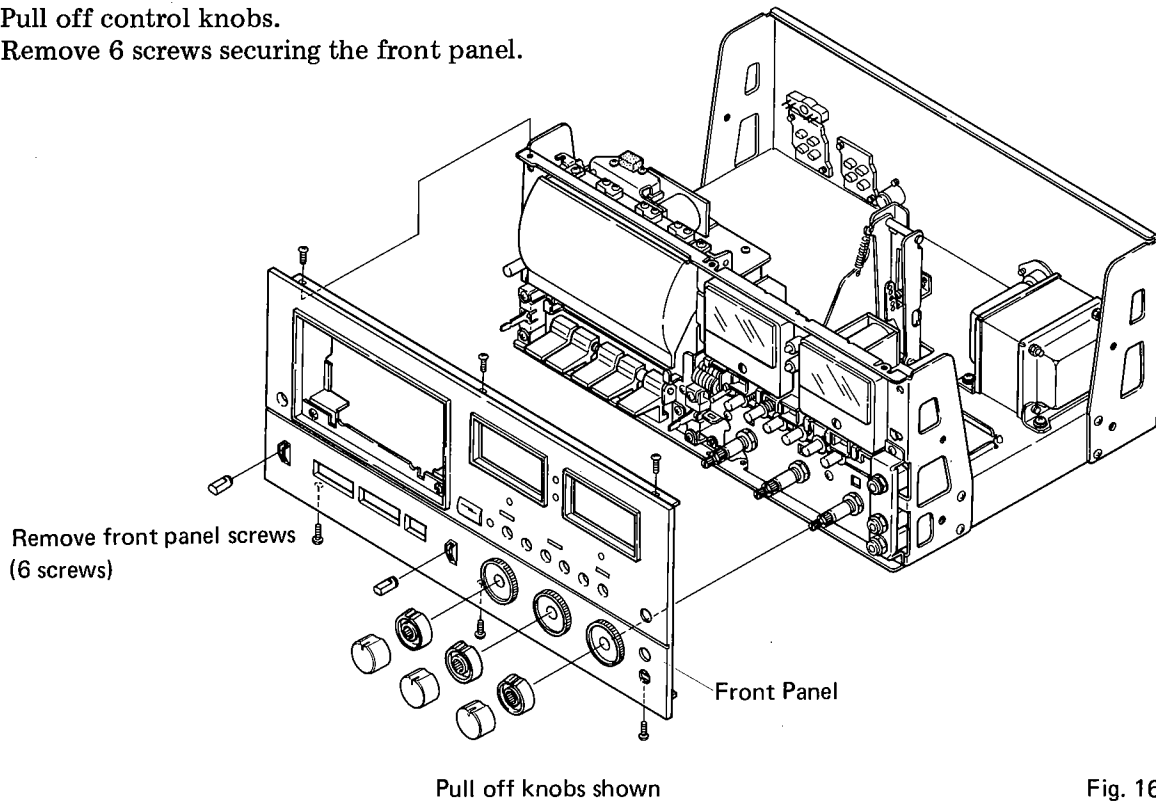

Fig. 16

7.4 TRANSPORT SECTION

Disconnect tape transport section connector.
Leads from heads are soldered. Unsolder only
When replacing heads.
Remove 4 screws "A" securing transport section.

NOTE:
When reinstalling the transport section, press it against the front panel and secure with 4 screws.

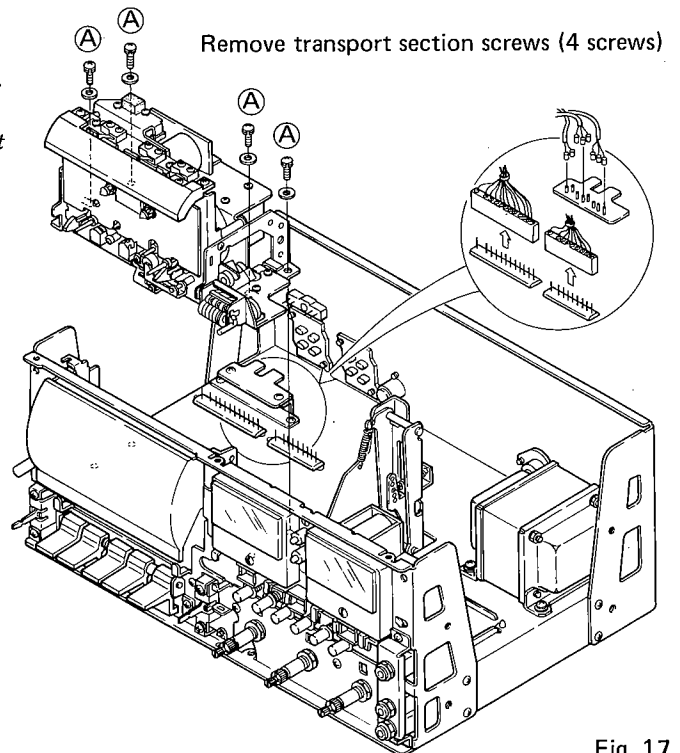

Fig. 17

7.5 MAIN MOTOR AND FF MOTOR

Remove transport section.

Take out the 4 screws "A" (in Fig. 18), then remove the 3 screws "B".

Remove the 3 screws "C" (Fig. 18), then take out 2 screws "D".

NOTE:

The following screws (2) are employed for mounting the FF motor.

Screws: PM 2.6 x 3

Washers: SW 2.6

If incorrect screws are used, FF motor will be irreparably damaged.

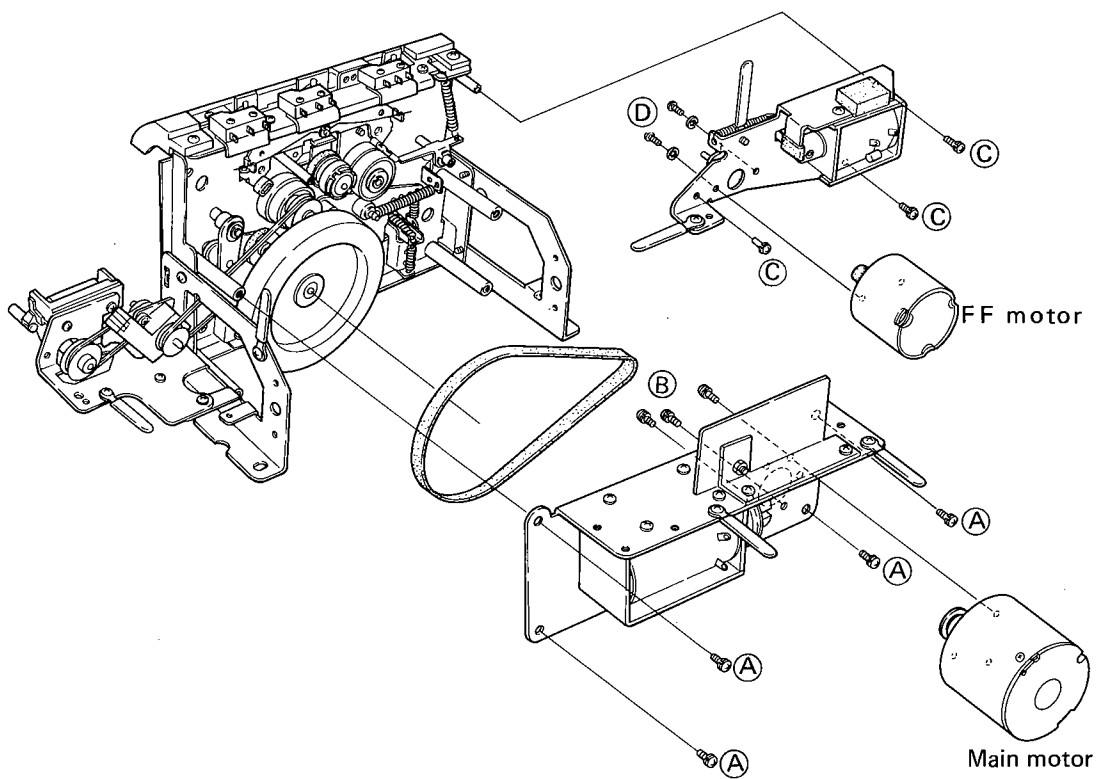
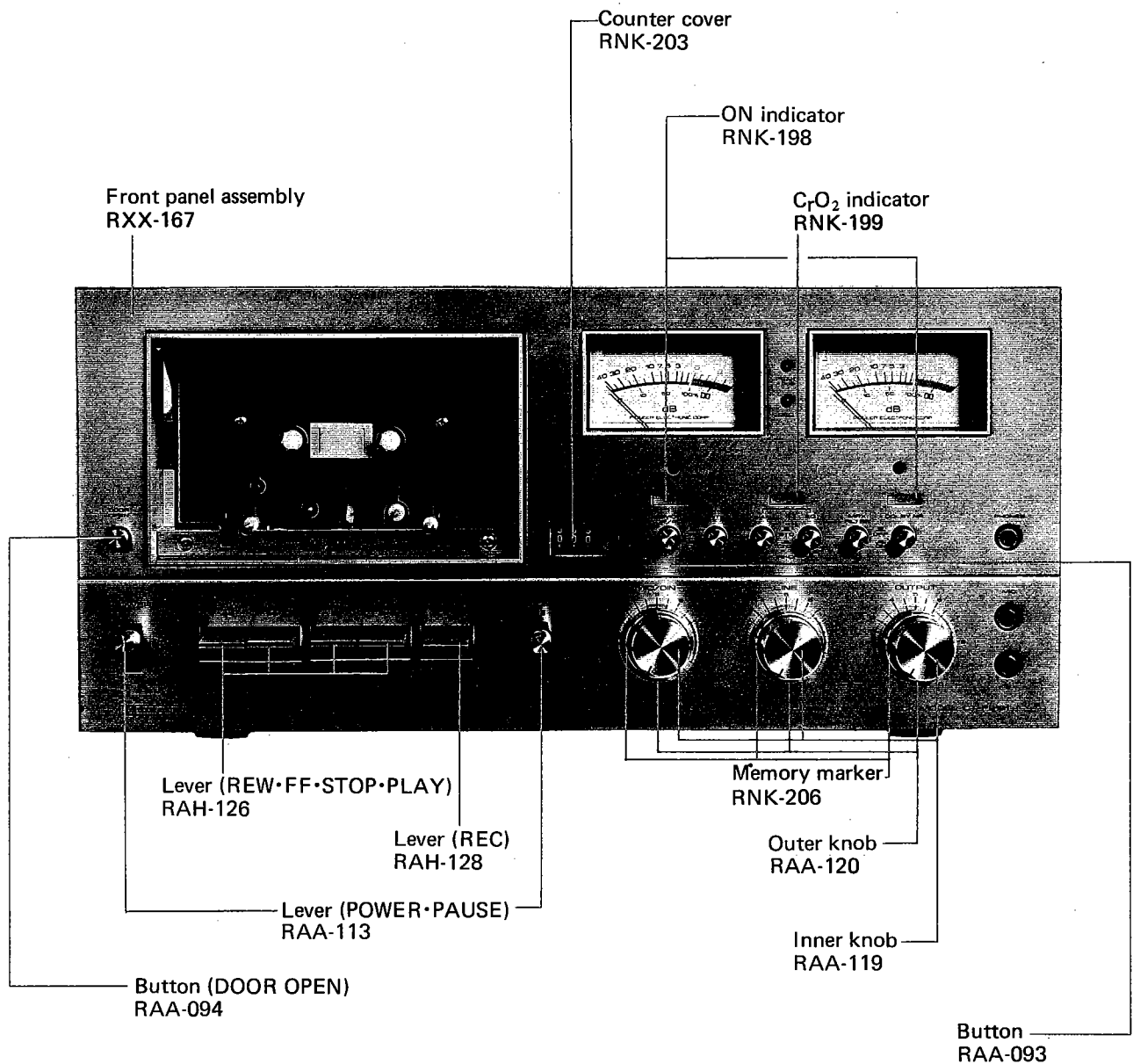

Fig. 18

8. PARTS LOCATIONS

8.1 FRONT VIEW



8.2 FRONT VIEW WITH PANEL REMOVED

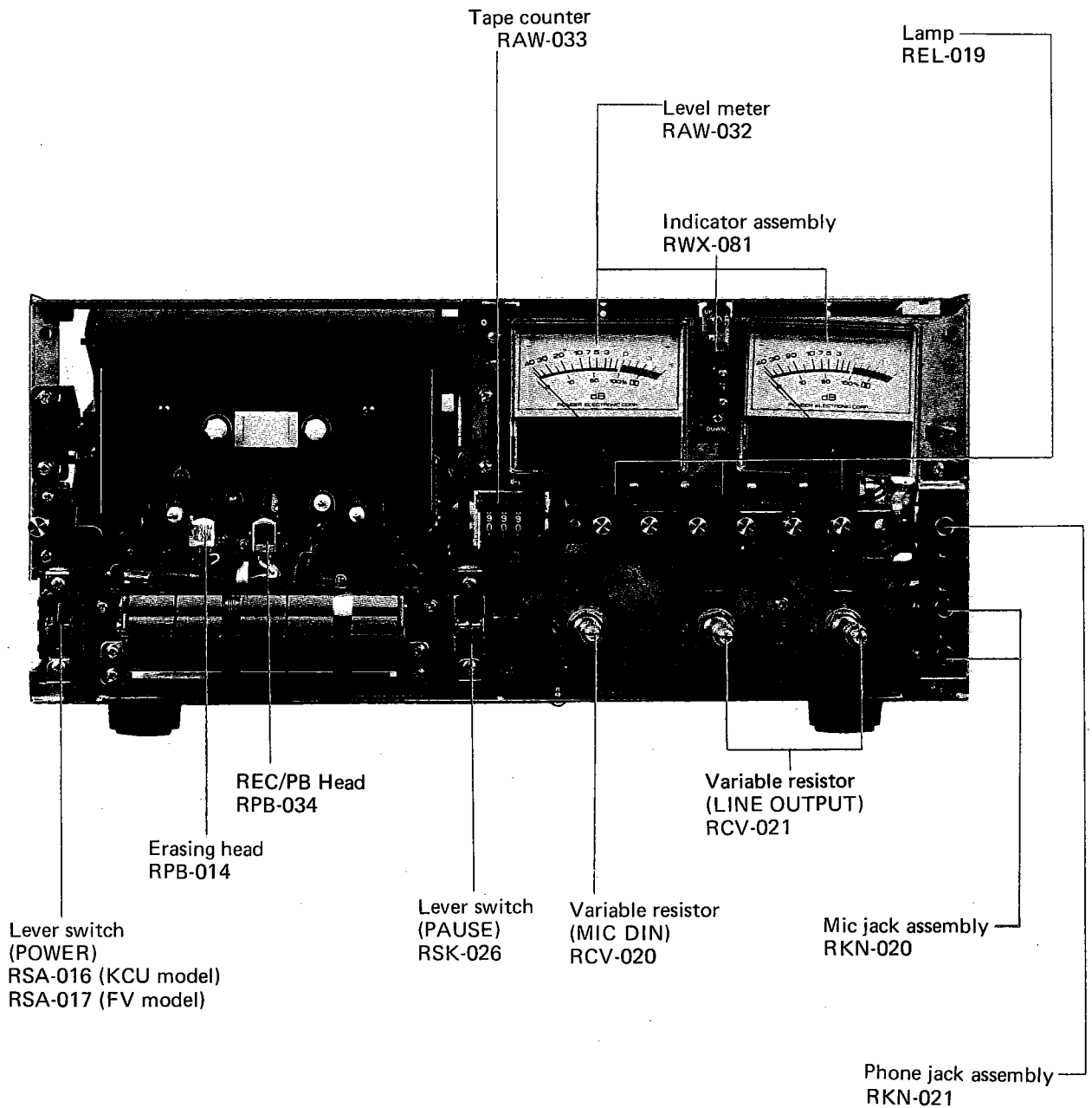

8.3 TOP VIEW (FV TYPE)

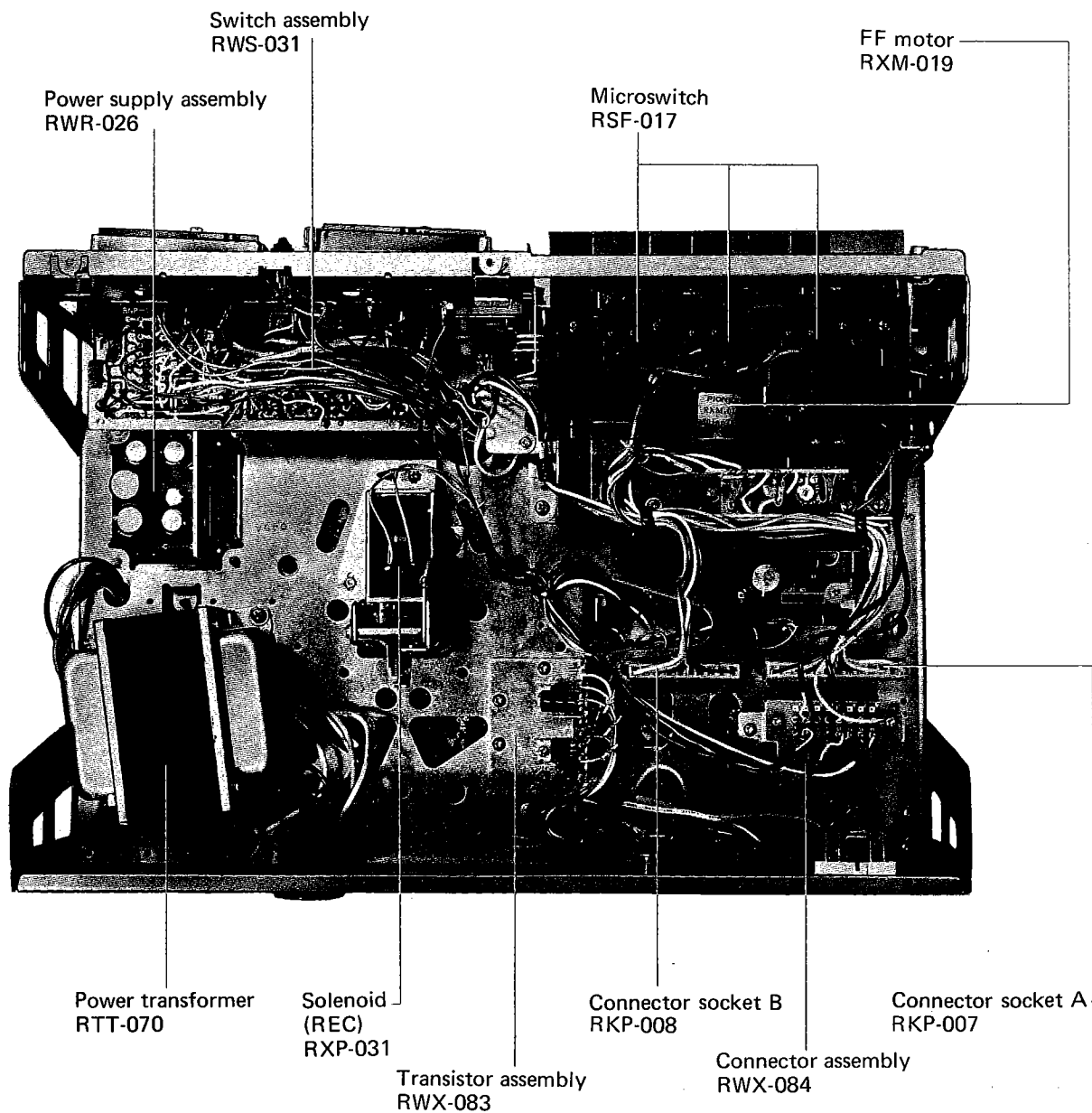

8.4 TOP VIEW (KCU TYPE)

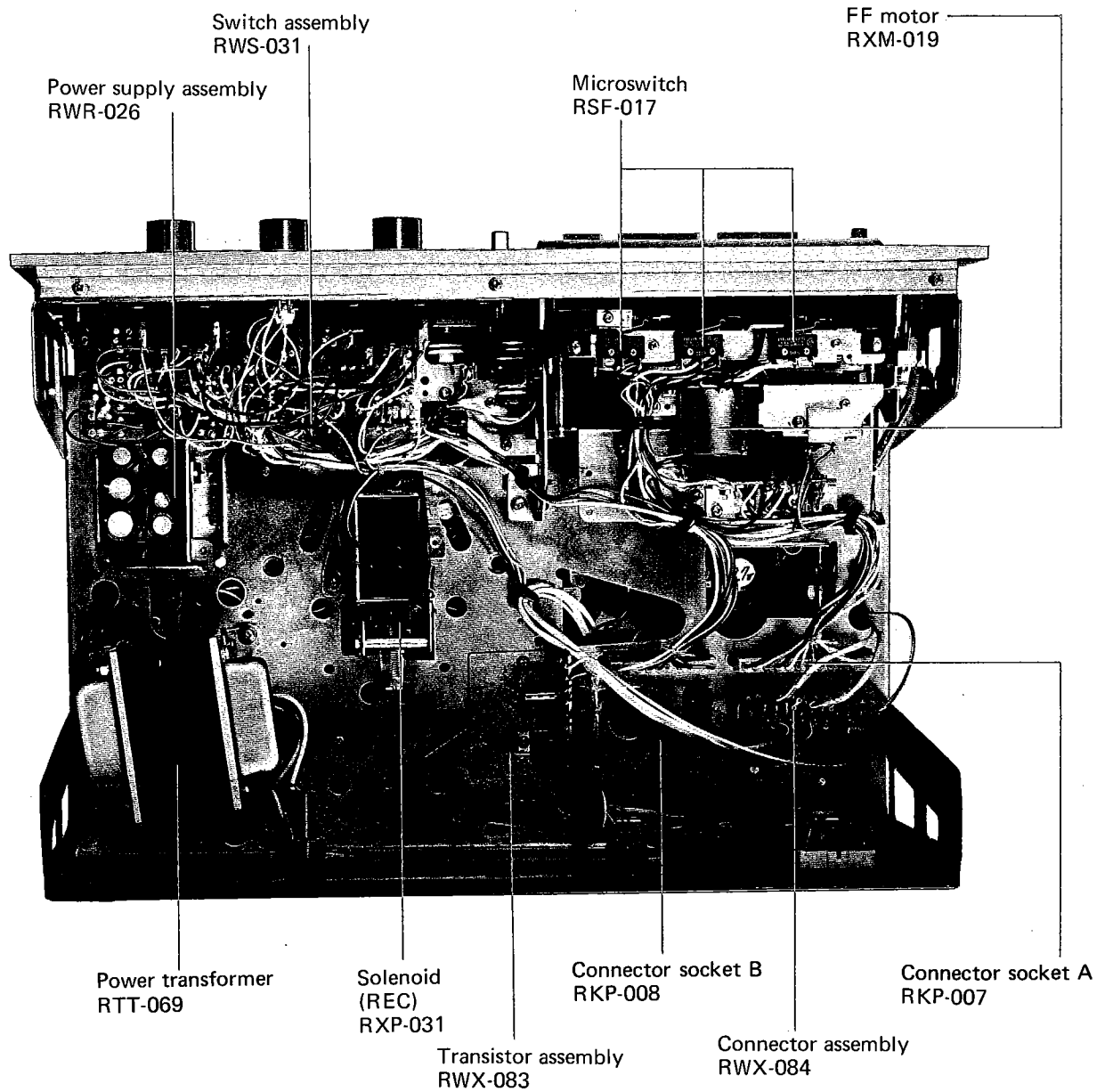

8.5 REAR VIEW (FV TYPE)

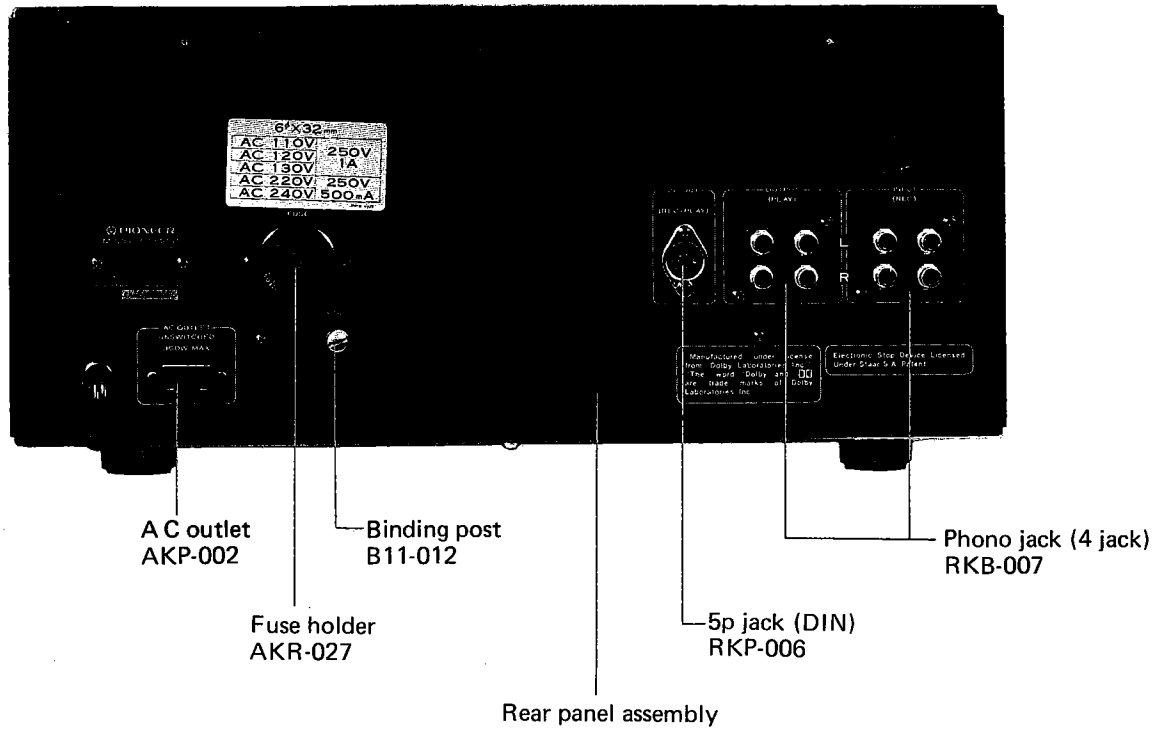

8.6 REAR VIEW (KCU TYPE)

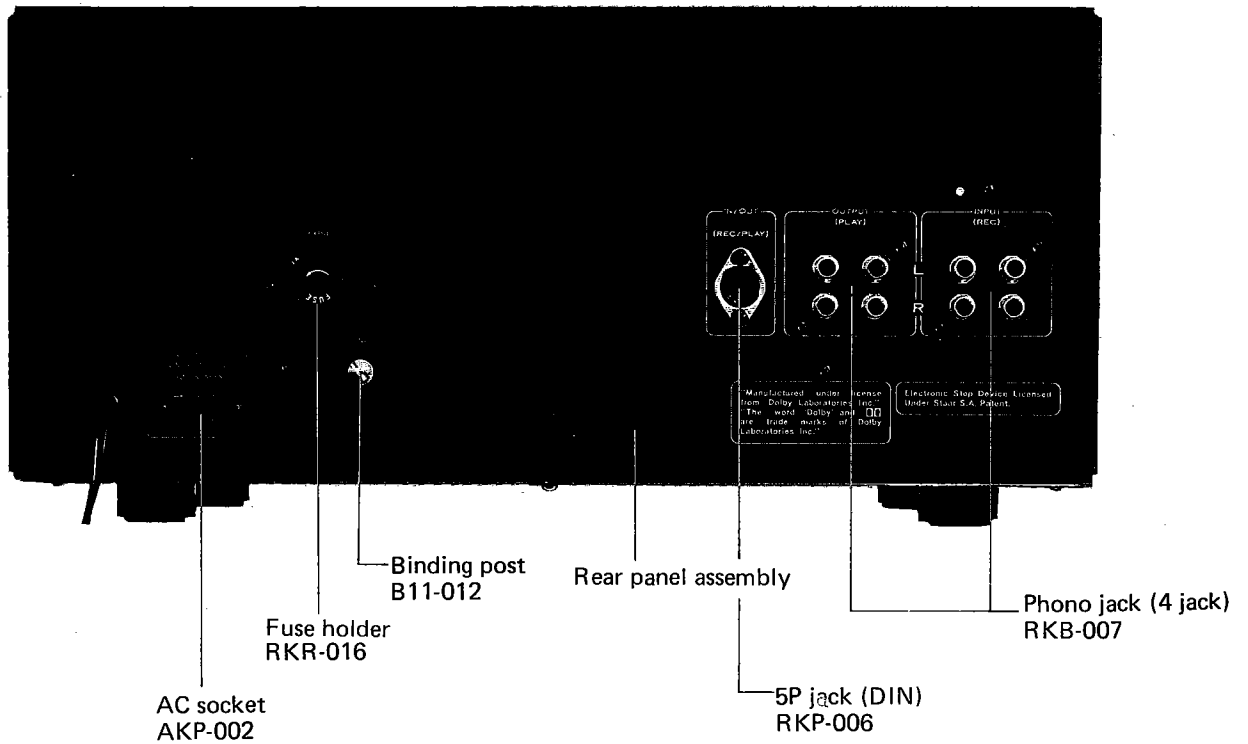

8.7 BOTTOM VIEW

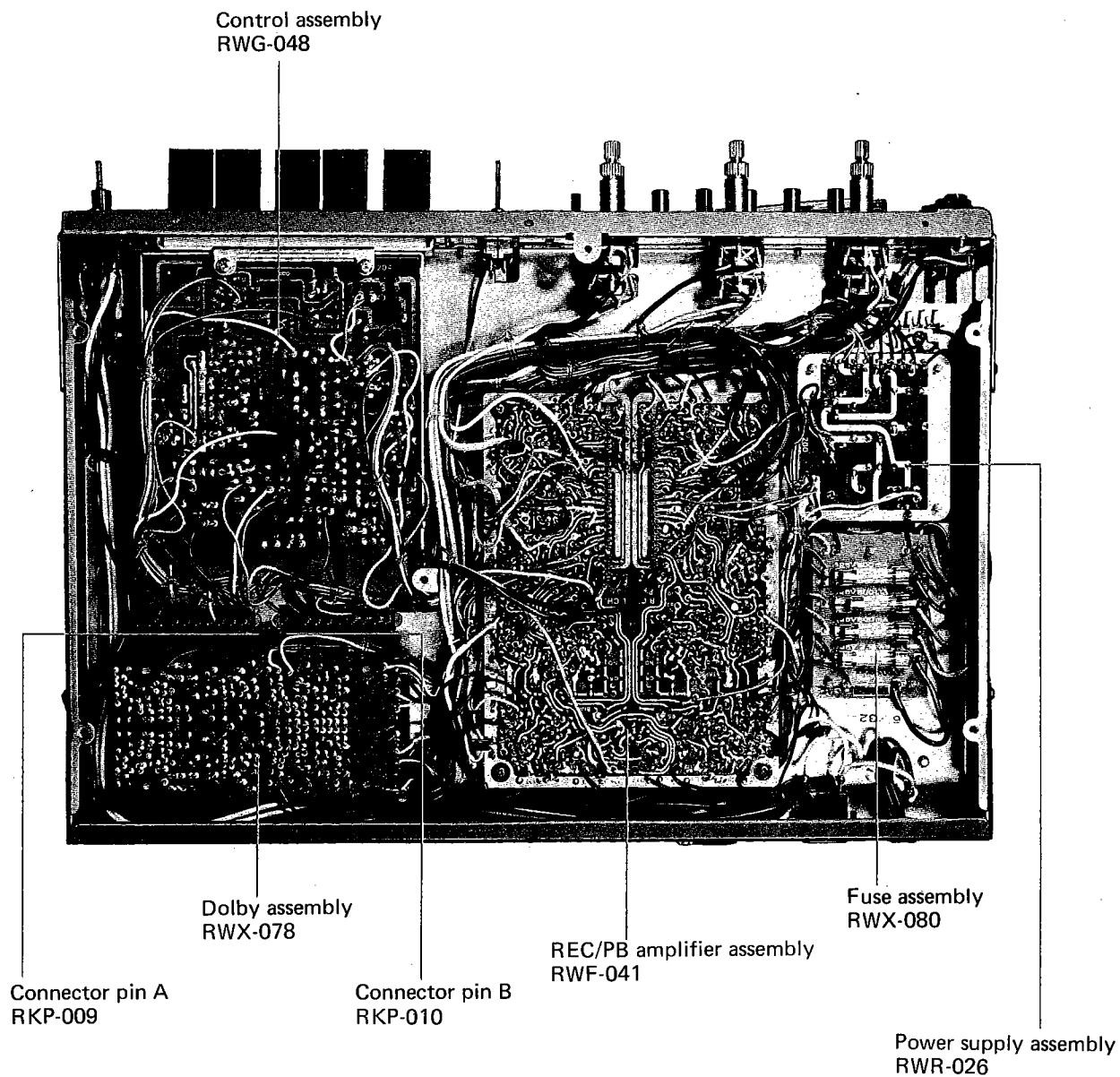

9. ELECTRICAL ADJUSTMENTS

Adjustments of the playback and recording systems are performed using STD-334 as a reference tape. Refer to Fig. 24 on page 33 for trimmer resistor and coil locations. The Line, MIC/DIN and Output controls are located on the front panel.

(Playback System)

9.1 HEAD AZIMUTH (PHOTO 1, Fig. 19)

1. Connect mV meter to the Output jacks and turn the Output controls ($VR_{105,205}$) to maximum.
2. Set the EQ Tape Selector Button to STD. Play reference tape STD-334 and adjust head azimuth so that both L and R channel outputs become maximum.
3. Apply screw sealing compound after adjusting.

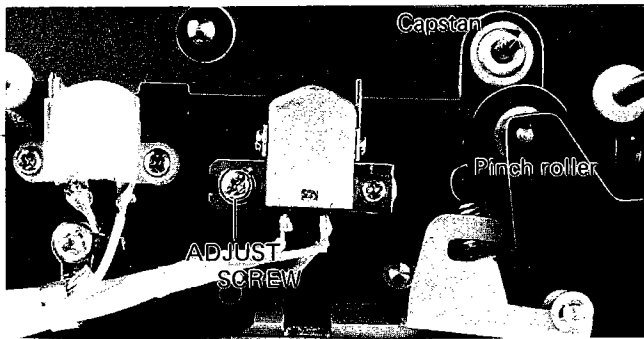

Photo 1

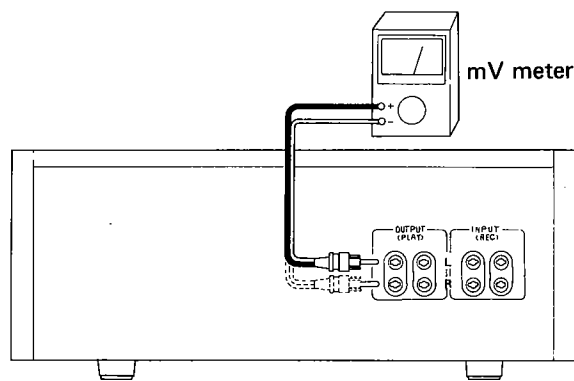

Fig. 19

9.2 PLAYBACK EQUALIZER (Fig. 19)

1. Set EQ Tape Selector button to STD and turn playback level trimmer resistors ($VR_{102,202}$) to maximum.
2. Play STD-334 333Hz/0dB and adjust Output controls $VR_{105,205}$ for -20dB at the Output jacks.
3. Play STD-334 6.3kHz/-20dB and adjust EQ trimmer resistors $VR_{104,204}$ so that the difference from the above (step 2) value becomes 0dB.
4. Set the Tape Selector to Chrome and confirm that the difference when 6.3kHz/-20dB is played (in respect to Step 2), becomes -4.5dB ± 1.5 dB.

9.3 PLAYBACK LEVEL (Fig. 21)

1. Connect mV meter to Dolby Ass'y OUT terminals (No. 15 & 16) and set Output controls as desired.
 2. Set Dolby NR button to ON. Play STD-334 333Hz/0dB and adjust $VR_{102,202}$ for -3.7dB indication on the mV meter.
- Perform this adjustment carefully as it determines the Dolby level setting.

Employ STD-334 test tape for adjustment and STD-331 for confirming frequency response.
0dB = 1V

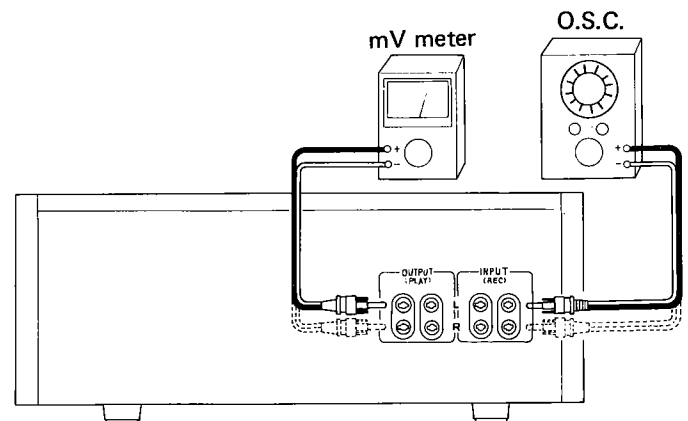

Fig. 20

9.4 0VU ADJUSTMENT (Fig. 21, Fig. 22)

1. Apply 333Hz/-10dB signal to Input jacks and set in recording mode.
2. Adjust Line controls to obtain -7.7dB output level at the Dolby Ass'y OUT terminals (No. 15, 16).
3. Adjust VR_{106,206} for 0VU indication on the level meters.

9.5 RECORDING CURRENT (Fig. 20, Photo 2)

1. Apply 333Hz/-10dB signal to Input jacks and set for recording mode.
2. Adjust recording controls for -10dB at the Output jacks.
3. Connect mV meter between No. 1 - No. 5 and No. 2 - No. 6 of the record/play assembly.
4. With Tape Selector at STD, adjust VR_{107,207} for 0.45mV indication on mV meter.

9.6 BIAS TRAP (Fig. 20, Fig. 24-E-F)

1. Set in recording mode and position of Line controls at maximum. Connect mV meter and oscilloscope to test points 95 and 96 of the record/play assembly. Adjust L_{102,202} for minimum waveform.
2. Set Bias Tape Selector to Chrome and connect mV meter to Output jacks.
3. Adjust L_{101,201} for minimum bias leakage level. Operate MIC/DIN and Line controls between minimum and maximum settings and confirm that leakage level is less than -45dB (less than 5.6mV).

9.7 RECORDING BIAS (Photo 2, Fig. 24-E, F)

1. Set in recording mode and position of Line controls to minimum.
2. Set BIAS Tape Selector to STD.
3. Connect mV meter between No. 1 - No. 5 and No. 2 - No. 6 of the record/play assembly. Adjust VR_{301,302} for 1.5mV indication.

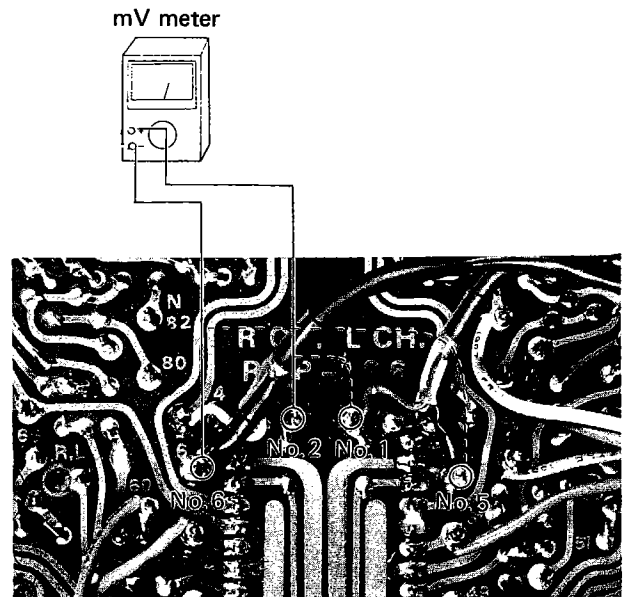

Photo 2

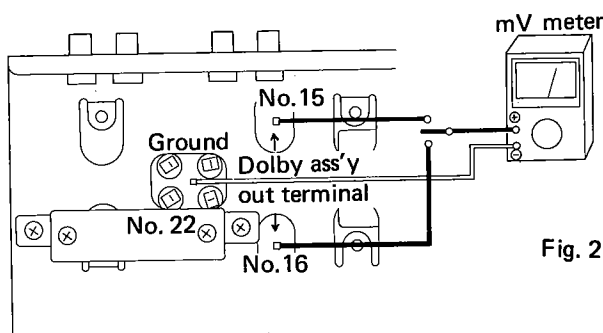

Fig. 21

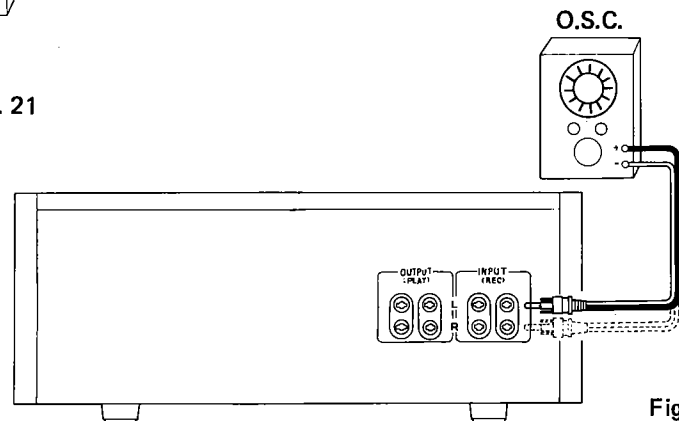

Fig. 22

9.8 RECORD/PLAYBACK FREQUENCY RESPONSE (Fig. 23)

1. Set BIAS and EQ to STD and Dolby NR to OFF.
2. Apply 333Hz/-30dB to Input jacks and set for recording mode. Adjust Line controls for -30dB at Output jacks.
3. Record 333Hz on STD-601 (or SONY C90-HF) tape.
4. Record 6.3kHz/-30dB and adjust VR_{301,302} so that the playback level difference with respect to the previous (Step 3) signal is +0.7dB.
5. Also confirm that recording and playback up to 12kHz is within specifications.
6. Set BIAS and EQ Tape Selectors to Chrome and record 333Hz and 6.3kHz on STD-602A (TDK C-60KR or equiv.). Adjust VR₆₀₁ of the switch assembly (RWS-031) so that with respect to 333Hz, 6.3kHz output level difference becomes $+1 \pm 0.5$ dB.

9.9 RECORDING LEVEL (Fig. 21, Fig. 22)

1. With BIAS and EQ Tape Selectors at STD, set Dolby NR to ON.
2. Apply 333Hz/-10dB to the Input jacks and connect mV meter to Dolby Ass'y OUT terminals (No. 15, 16). Adjust Line controls for -7.7dB indication.
3. Record 333Hz/-10dB on STD-601 (SONY C-90HF or equiv.) and adjust VR_{107,207} for -7.2dB playback level at the Dolby Ass'y OUT terminals (No. 15, 16).
4. Set BIAS and EQ Tape Selectors to Chrome. Record and play back 333Hz/-10dB on STD-602A (TDK C-60KR or equiv.). Confirm that the signal at Dolby Ass'y OUT terminals is -7.7 ± 1.5 dB.

9.10 CONFIRM LIMITER OPERATION (Fig. 20)

1. Set in REC mode and apply 333Hz/-10dB to the Input jacks. Adjust Line controls for -10dB at the Output jacks.
2. Increase the input level by +20dB; the Output jack signal will become +10dB. Set the limiter button ON and confirm that the Output jack level becomes $-6\text{dB} \pm 1\text{dB}$.

9.11 CONFIRM PEAK INDICATOR OPERATION (Fig. 20)

1. Set in REC mode and apply 333Hz/-10dB to the Input jacks. Turn the Line controls to minimum.
2. Turn only the L channel Line control and confirm that the peak indicator lights when the L channel Output jack signal reaches $-5\text{dB} \pm 1\text{dB}$.

3. Repeat this for the R channel, then for both channels simultaneously.

9.12 LEVEL METER SCALE ACCURACY (Fig. 21)

1. Set in REC mode and apply 333Hz/-10dB. Adjust Line controls for 0dB indication on level meters. increase the input level at the Input jacks by +4dB. At -6dB, confirm that the level meters indicate 4 ± 0.5 dB.
3. Reduce the input level to -30dB and confirm that the level meters indicate $-20\text{dB} \pm 2\text{dB}$. Employ test tape STD-331 to confirm frequency response.

Play back Frequency Response

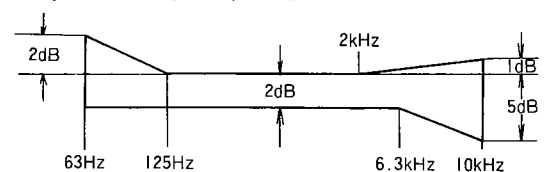

Record/Playback Frequency Response
NORMAL, DOLBY(OFF)

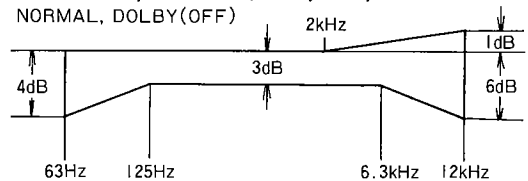

NORMAL DOLBY-ON

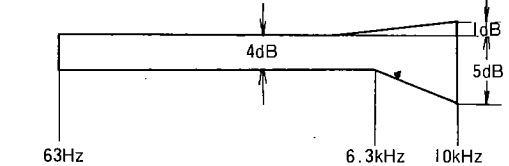

CHROME DOLBY-OFF

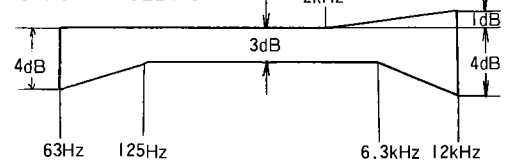

CHROME DOLBY-ON

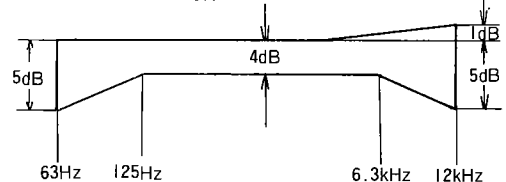

Fig. 23

9.13 DOLBY ADJUSTMENT (Fig. 21, Fig. 22)

1. Connect mV meter to terminals No. 15 and 16 of the Dolby Ass'y.
2. Set Dolby NR button to ON.
3. Turn VR_{401,501} (L & R channels) of Dolby Ass'y to maximum.
4. With set in recording mode, apply 5kHz signal to the Input jacks.
5. Adjust Input level controls for 4.7dBv indication on mV meter.
6. Reduce the Input jack level by 40dB.
7. Adjust VR_{402,502} for -34.7dBv indication on mV meter (Fig. 24-c).
8. Reduce level applied in Step 4 by 30dB.
9. Adjust VR_{401,501} for 26.7dBv indication on mV meter.

Fig. 24

Fig. 24-C

Fig. 24-D

Fig. 24-E

Fig. 24-F

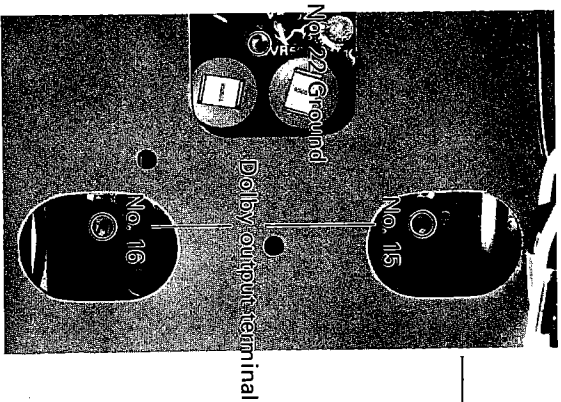

Fig. 24-B

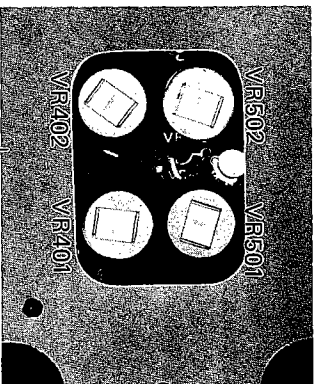

Fig. 24-C

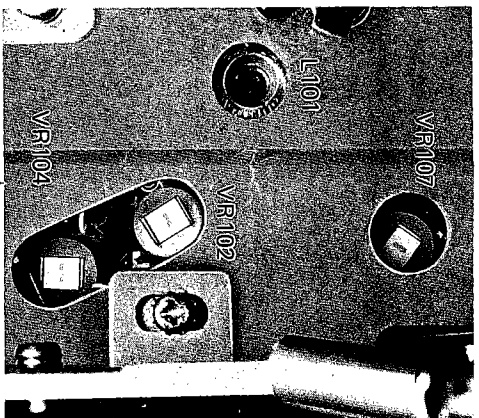

Fig. 24-D

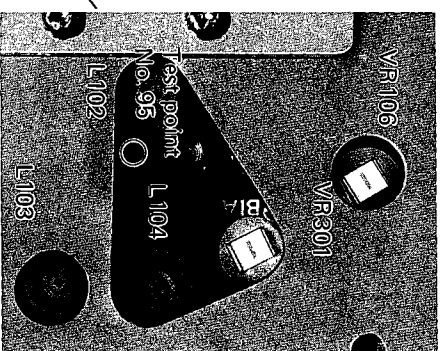

Fig. 24-E

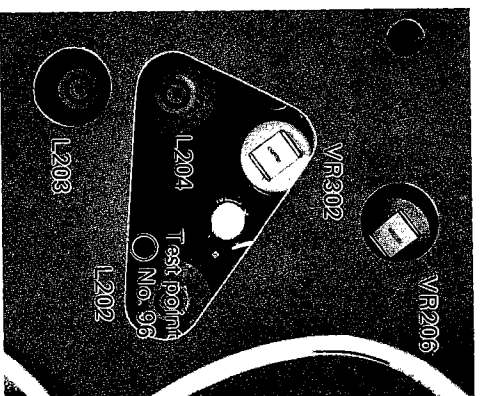

Fig. 24-F

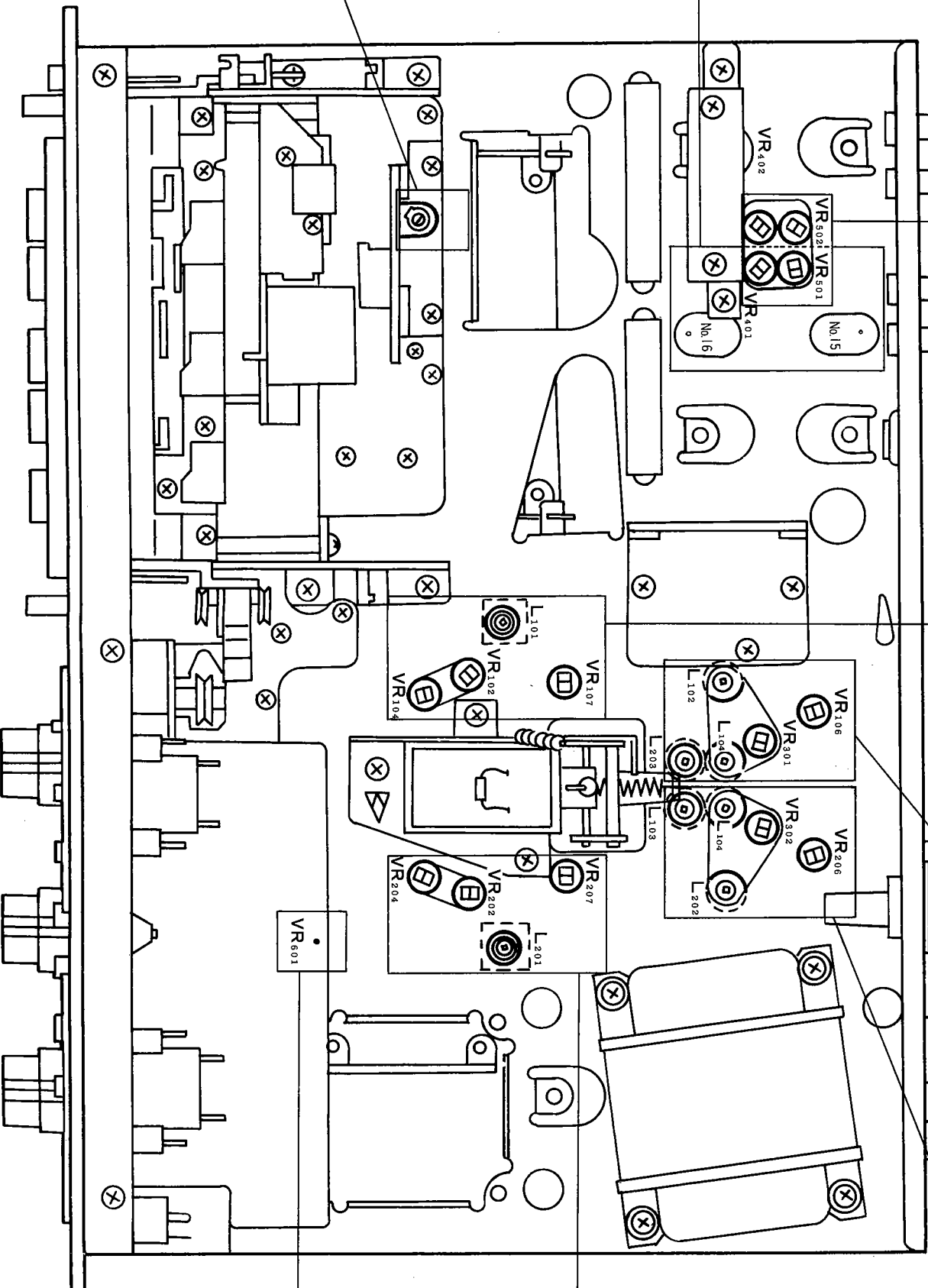

Fig. 24-G

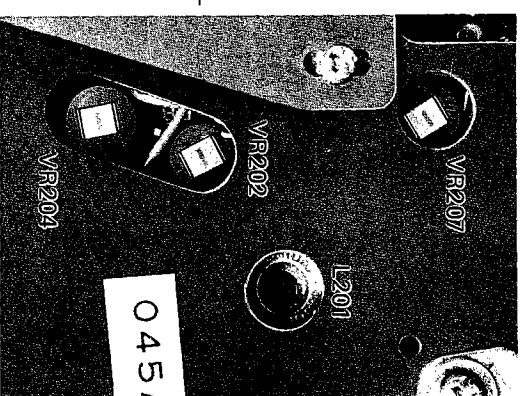

Fig. 24-H

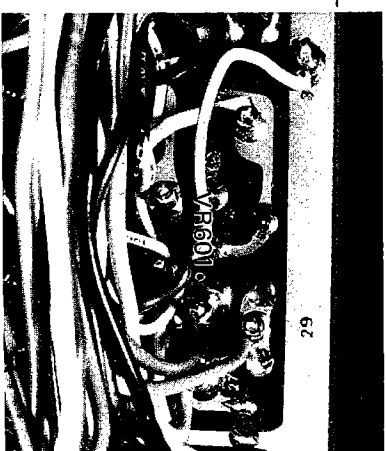
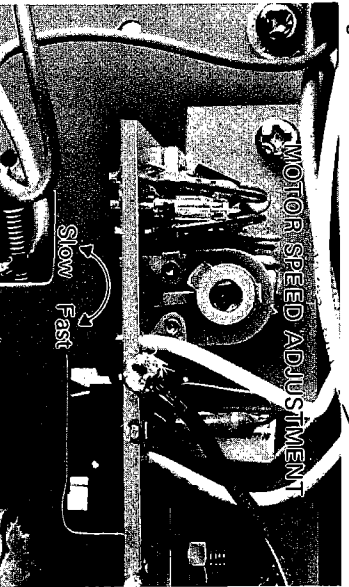

Fig. 24-A



MECHANICAL ADJUSTMENTS

WOW AND FLUTTER

and flutter in this set are specified to be within 0.07%. If excessive, inspect as follows and correct by any necessary cleaning, adjustments and replacements.

Capstan belt, vibrating or dirty.

Pinch roller thrust loose.

Capstan belt dirty or aged.

Pinch roller dirty or pressure incorrect.

Take up idler dirty, eccentric or pressure incorrect.

Take up reel hub torque irregular.

Take up reel hub torque irregular.

Insufficient or irregular back tension.

Pressure switch torque irregular due to counter-effective cassette (tape) being used.

PINCH ROLLER PRESSURE (Photo 3, 4)

Adjust as described on page 22 and remove tape transport assembly. Connect transport assembly connectors to the main unit in order to allow mechanical operation.

Set for play mode. Apply a 500g tension gauge to the test point and separate pinch roller from capstan by about 1 — 2mm. Next allow the pinch roller to contact the capstan, and confirm that when rotation begins the gauge indicates 350 — 450g. (Also confirm at this time that there is a space between the pinch roller drive arm and head base.)

350 — 450g is not obtained, change the spring anchor point on the pinch roller drive arm.

TAPE SPEED (Fig. 25)

Adjust trimmer resistor on capstan motor head. Clockwise rotation increases tape speed, while counter-clockwise rotation decreases the speed.

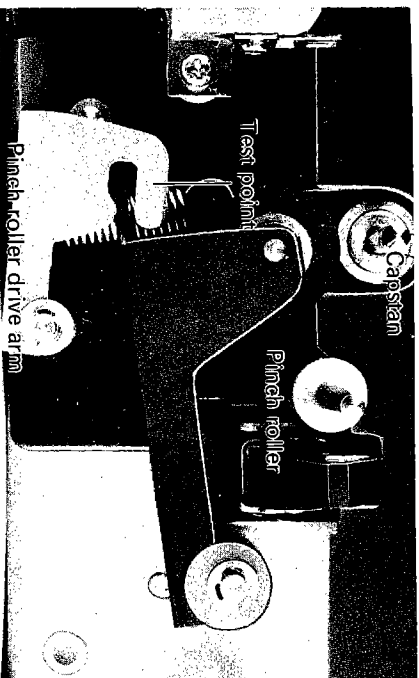

Photo 3

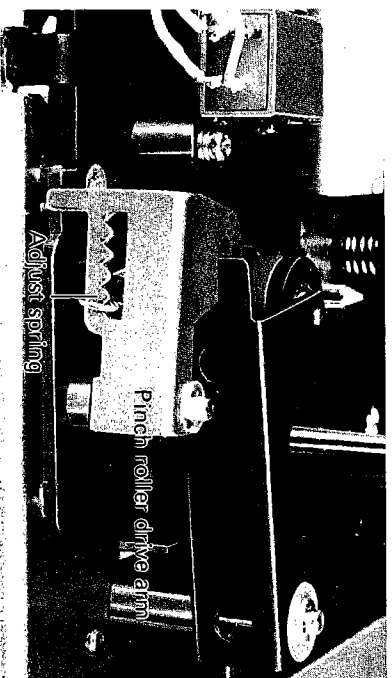

Photo 4

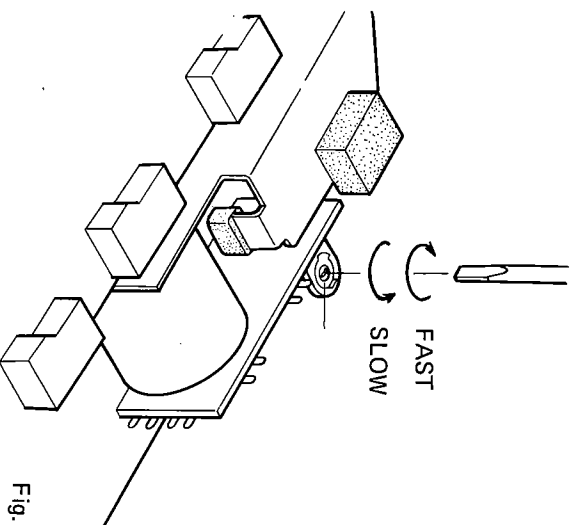

Fig. 25

10.4 REEL HUB TORQUE (Photo 5, 6, Fig. 26)

If the acceptable values indicated in the table are not obtained, clean idlers, reel hubs and other roller contacting surfaces and again measure torque values. If the values are still outside acceptable limits, replace the take up reel hub or complete reel hub assembly.

To replace the take up and supply reel hubs, as shown in Fig. 26, take out screws A and remove panel A. Then remove screws B and C, and finally screws D.

TAKE UP REEL	
PLAY	Take up torque 40 ~ 65g-cm
FF	Take up torque 75 ~ 130g-cm
REW	Back tension 8g-cm less than
SUPPLY REEL	
PLAY	Back tension 4 ~ 8g-cm
REW	Take up torque 75 ~ 130g-cm

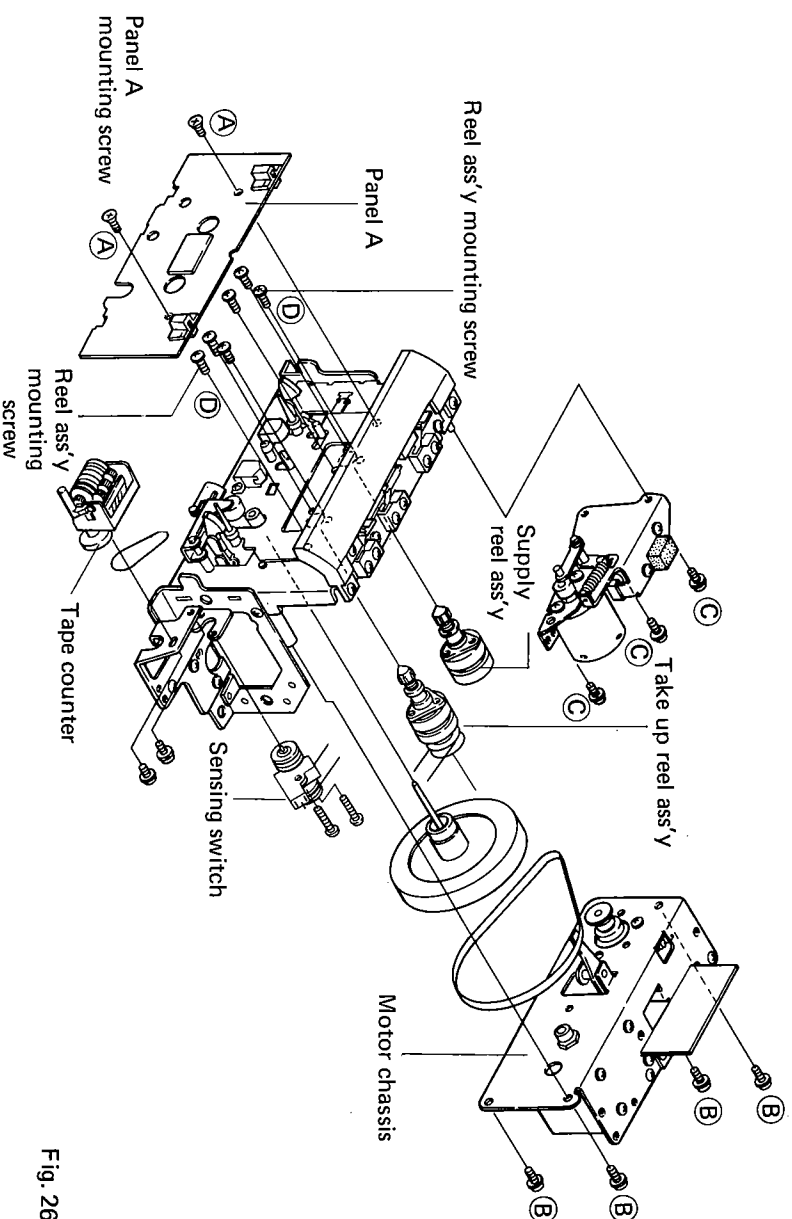

Fig. 26

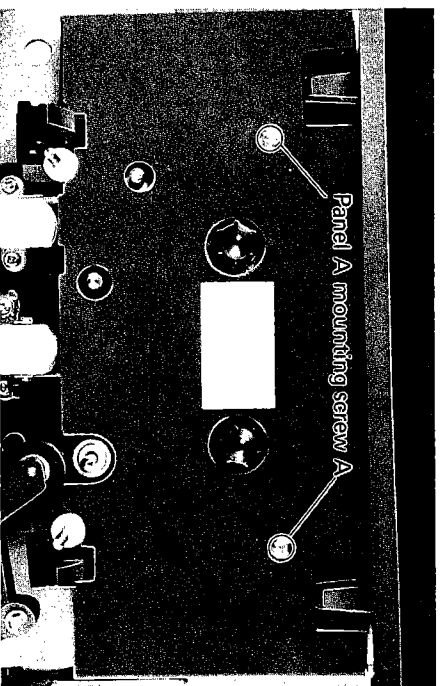

Photo 5

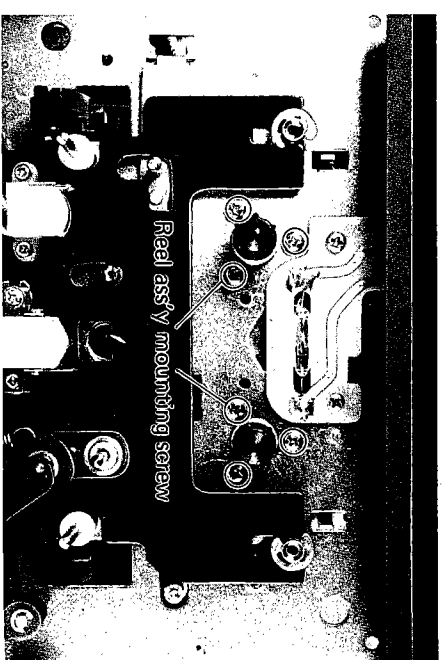

Photo 6

10.8 LEVEL METER LOOSENESS

1. Adjust as shown in Fig. 31.
2. Caution is required, as excessive bending can damage the meter.

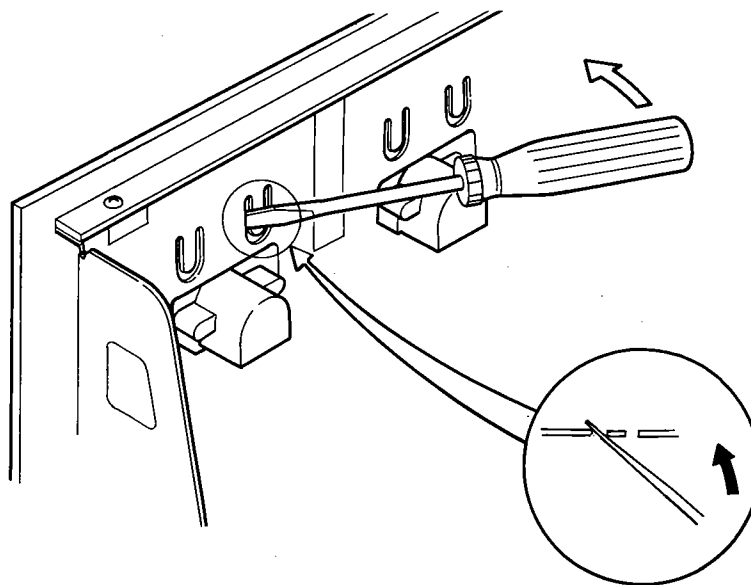

Fig. 31

10.9 MICROSWITCHES

Three microswitches are employed for erasure prevention, cassette detection and automatic chrome tape selection. If any of these are replaced, install cassette and confirm proper operation.

11. SCHEMATIC DIAGRAMS PC BOARD PATTERNS AND PART LISTS

11.1 SCHEMATIC DIAGRAMS AND MISCELLANEOUS PARTS

NOTE:

- Capacitors: in μF unless otherwise noted $p:pF$
- Resistors: in Ω , $\frac{1}{4}W$ unless otherwise noted $k:k\Omega$, $M:M\Omega$

CAPACITOR and RESISTORS

Symbol	Description	Part No.
C1	Ceramic 0.01 1.4kV	C43-003
R1	Carbon film 100k	RD $\frac{1}{4}$ PS 104J
R2	Carbon film 100k	RD $\frac{1}{4}$ PS 104J
VR101	LINE REC LEVEL control	RCV-021
VR201	LINE REC LEVEL control	RCV-021
VR103	MIC/DIN REC LEVEL control	RCV-021
VR203	MIC/DIN REC LEVEL control	RCV-021
VR105	OUTPUT LEVEL control	RCV-020
VR205	OUTPUT LEVEL control	RCV-020

OTHERS

Symbol	Description	Part No.
T1	Power transformer FV model KCU model	RTT-070-0 RTT-069-0
PL4	Lamp (DOLBY)	REL-019-0
PL5	Lamp (MEMORY)	REL-019-0
PL6	Lamp (CHROME)	REL-019-0
	Solenoid A (PINCH solenoid)	RXP-029-0
	Solenoid B (REC solenoid)	RXP-031-0
	Solenoid C (BRAKE solenoid)	RXP-030-0
	Solenoid D (RESET solenoid)	RXP-032-0
	Level meter	RAW-032-0
FU1	Fuse (KCU model) 1A 125V Fuse (FV model, 110~130V) 1A 250V Fuse (FV model, 220~240V) 0.5A 250V (Surge proof)	

10.5 FF/REW TRANSMISSION (Photo 7, 8, Fig. 27)

The FF — REW selecting mechanism functions by not only changing the direction of rotation of the motor, but also automatically moving the FF idler. The force of this movement can be adjusted by the FF lever spring, shown in Photo 8.

Tension increases as the spring is moved in the direction indicated by the arrow.

1. After adjusting the spring, be sure to operate FF and REW several times. If abnormal vibration or other difficulty is caused, return the spring to its original position.
2. If adjusting the spring does not correct the problem, replace the FF idler. (Fig. 27)

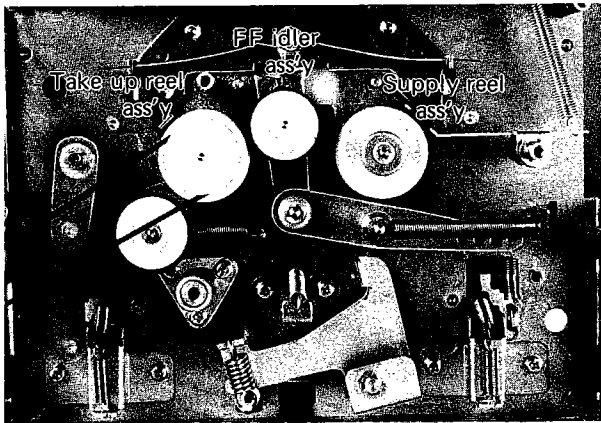

Photo 7

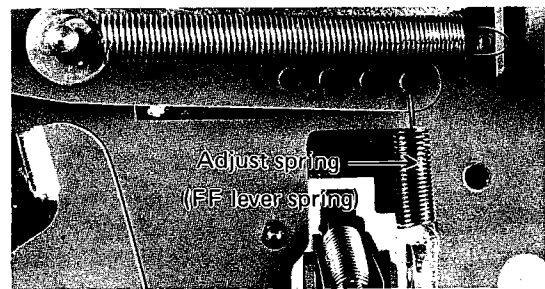

Photo 8

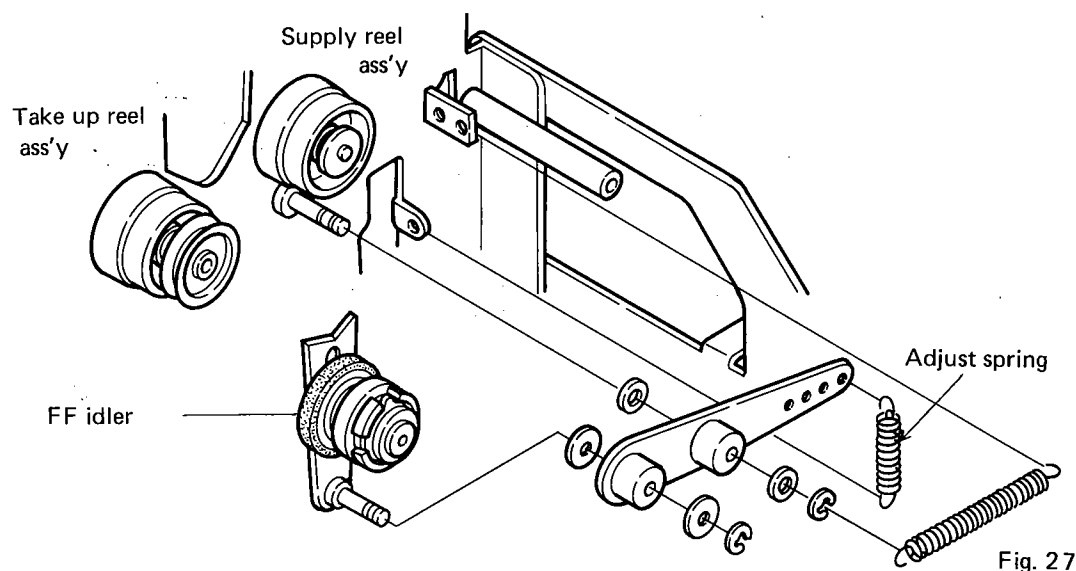
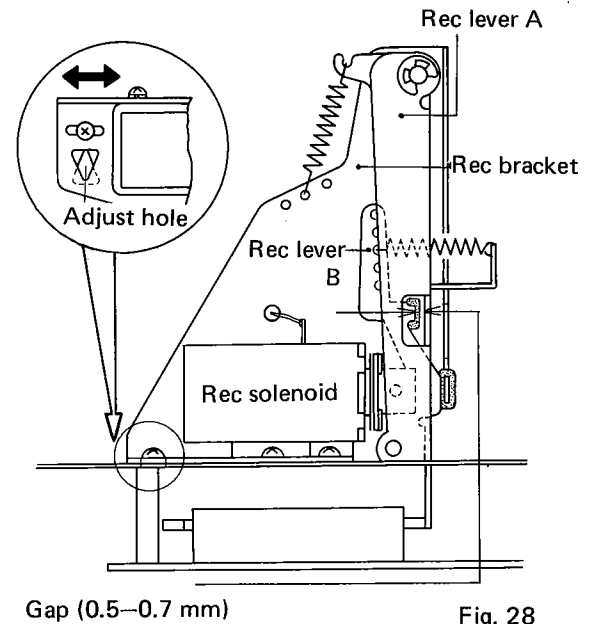

Fig. 27

10.6 RECORD LEVER A AND B OPERATION (Fig. 28)

1. Set in recording mode, insert a screwdriver into the adjustment hole (Fig. 28) and adjust the record bracket so that the gap indicated by the arrows becomes 0.5 – 0.7mm.
2. After adjusting, confirm that the selector switch of the record/play ass'y can be properly selected. Also note that when the REC solenoid is not operating, the selector switch and record lever A do not contact.
3. After completing adjustment, tighten the 3 screws loosened for adjustment and apply sealing compound.



10.7 REPLACING PLASTIC DOOR (Fig. 29,30)

1. Remove cover (2 screws).
2. Remove the E-type washer.
3. Use a screwdriver to bend the angles shown in Fig. 29 outward and remove the door.
4. Take out side screws (4 screws) and remove retainer.
5. Adjust these screws so that the retainer pin engages properly with the indented portion of the door lever.

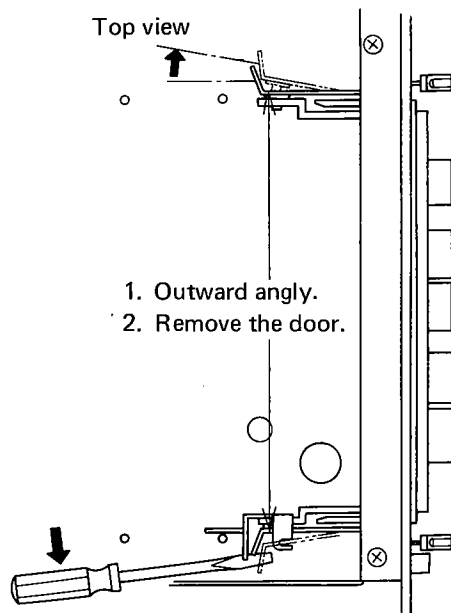

Fig. 29

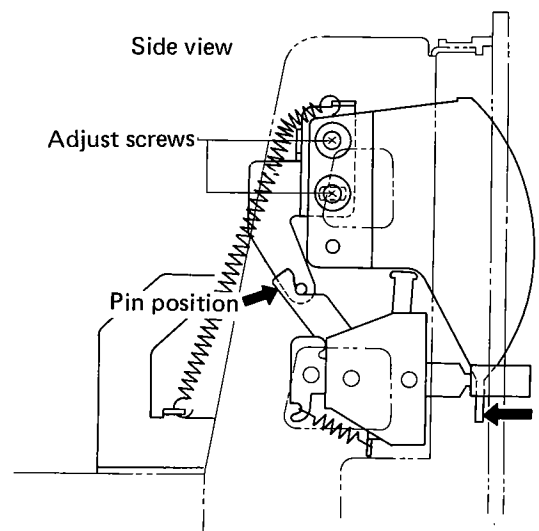
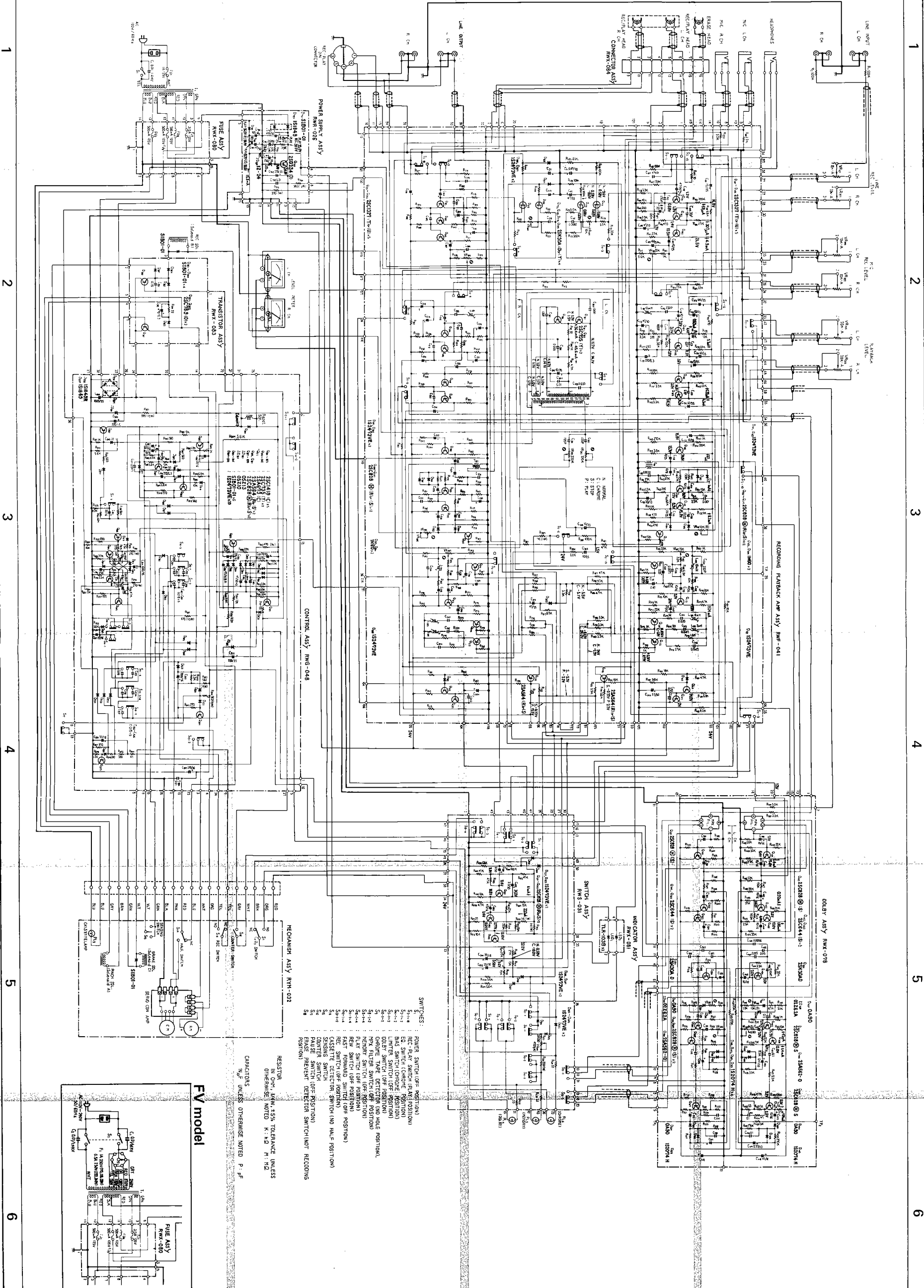
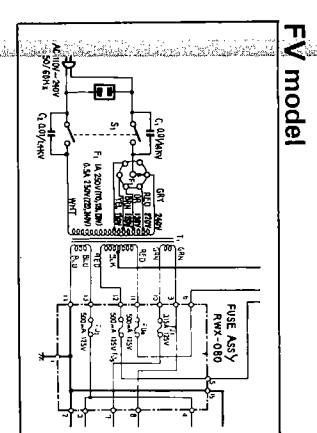

Fig. 30



- SWITCHES:**
- S1 POWER SWITCH (OFF POSITION)
 - S2 REC-PAV SWITCH (PAV POSITION)
 - S3 EQ SWITCH (CHORUS POSITION)
 - S4 BASS SWITCH (CHORUS POSITION)
 - S5 LIMITER SWITCH (OFF POSITION)
 - S6 DOLBY SWITCH (OFF POSITION)
 - S7 PEQ SWITCH (OFF POSITION)
 - S8 HONEY SWITCH (OFF POSITION)
 - S9 PLAY SWITCH (OFF POSITION)
 - S10 CASSETTE SWITCH (OFF POSITION)
 - S11 SENSING SWITCH
 - S12 PAUSE SWITCH (OFF POSITION)
 - S13 PAUSE PRESENT DETECTOR SWITCH (NOT RECORDING POSITION)
 - S14
 - S15
 - S16
 - S17
 - S18
- RESISTOR:**
IN OHMS 1/4W .25% TOLERANCE UNLESS OTHERWISE NOTED R-1A R-1B
- CAPACITORS:**
IN μ F UNLESS OTHERWISE NOTED P-PF



1.2 REC/PB AMPLIFIER ASSEMBLY (RWF-041)

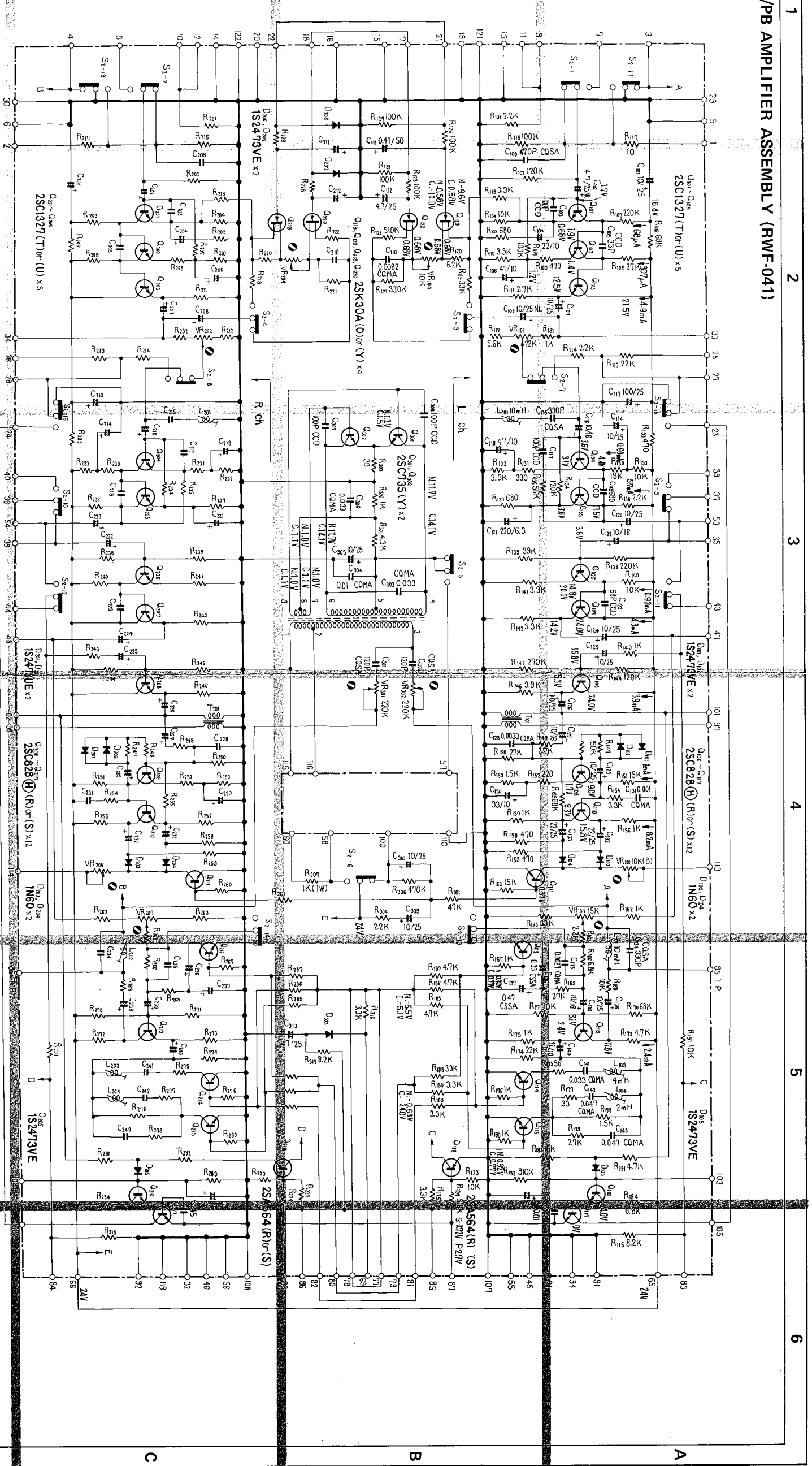

2SA564
2SC828 (H)
2SC1327



2SK30A



2SC735



S2-1-18 REC-PLAY SW. (PLAY POSI.)

D

C

B

A

1 2 3 4 5 6

1 2 3 4 5 6

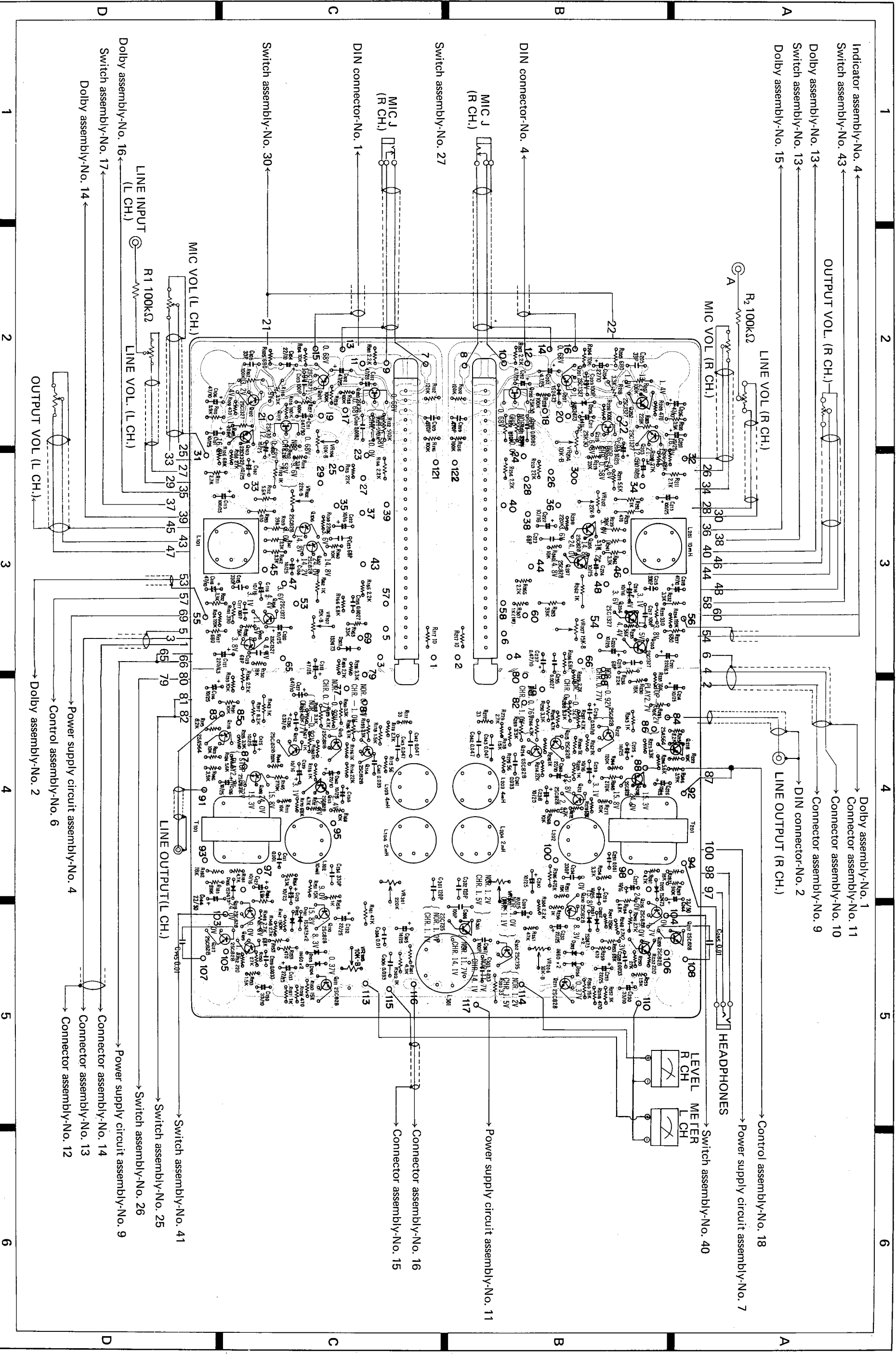

1 Indicator assembly-No. 4
 Switch assembly-No. 43
 Dolby assembly-No. 13
 Switch assembly-No. 13
 Dolby assembly-No. 15

2 OUTPUT VOL. (R CH.)
 LINE VOL (R CH.)
 MIC VOL (R CH.)

3

4 Dolby assembly-No. 1
 Connector assembly-No. 11
 Connector assembly-No. 10
 Connector assembly-No. 9
 LINE OUTPUT (R CH.)

5 HEADPHONES
 LEVEL METER
 R CH
 L CH
 Switch assembly-No. 40
 Power supply circuit assembly-No. 7
 Control assembly-No. 18

6

1 MIC J (R CH.)
 DIN connector-No. 4
 Switch assembly-No. 27

2 MIC J (R CH.)
 DIN connector-No. 1
 Switch assembly-No. 30

3

4

5

6

1 LINE INPUT (L CH.)
 R1 100KΩ
 LINE VOL. (L CH.)

2

3

4

5

6

list of REC/PB Amplifier Assembly (RWFF-041)

ATORS

Description	Part No.
Electrolytic	CEA 100P 25
Electrolytic	RCH-017
Ceramic	CCDSL 101K 50
Electrolytic	CEA 220P 10
Ceramic	CCDSL 330K 50
Electrolytic	CEA 470P 10
Electrolytic	CEA 100P 25
Electrolytic	RCH-022
Styrol	RCE-014
Mylar	CQMA 822K 25
Electrolytic	CEA R47P 50
Electrolytic	CEA 4R7P 50
Electrolytic	CEA 101P 25
Electrolytic	CEA 100P 25
Styrol	RCE-008
Electrolytic	CEA 100P 16
Ceramic	CCDSL 101K 50
Electrolytic	CEA 470P 10
Ceramic	CCDSL 680K 50
Electrolytic	CEA 100P 25
Electrolytic	CEA 221P 6R3
Electrolytic	CEA 100P 16
Ceramic	CCDSL 680K 50
Electrolytic	CEA 100P 25
Electrolytic	CEA 100P 25
Electrolytic	CEA 100P 25
Electrolytic	CEA 100P 16
Electrolytic	CEA 100P 16
Ceramic	CCDSL 680K 50
Electrolytic	CEA 100P 25
Electrolytic	CEA 100P 10
Electrolytic	CEA 330P 10
Mylar	CQMA 102K 50
Electrolytic	CEA 220P 25
Electrolytic	CEA 220P 25
Styrol	RCE-008
Mylar	CQMA 272K 50
Electrolytic	CSSA R33M 10
Electrolytic	CSSA R47M 10
Electrolytic	CEA 100P 25
Electrolytic	CEA 100P 16
Electrolytic	CEA 220P 10
Mylar	CQMA 333K 50
Mylar	CQMA 473K 50
Mylar	CQMA 473K 50
Electrolytic	CEA 2R2P 50
Mylar	CQMA 103K 50
Electrolytic	CEA 100P 25
Electrolytic	RCH-017
Ceramic	CCDSL 101K 50

Symbol	Description	Part No.
C204	Electrolytic	CEA 220P 10
C205	Ceramic	CCDSL 330K 50
C206	Electrolytic	CEA 470P 10
C207	Electrolytic	CEA 100P 25
C208	Electrolytic	RCH-022
C209	Styrol	RCE-014
C210	Mylar	CQMA 822K 50
C211	Electrolytic	CEA R47P 50
C212	Electrolytic	CEA 4R7P 50
C213	Electrolytic	CEA 101P 25
C214	Electrolytic	CEA 100P 25
C215	Styrol	RCE-008
C216	Electrolytic	CEA 100P 16
C217	Ceramic	CCDSL 101K 50
C218	Electrolytic	CEA 470P 10
C219	Ceramic	CCDSL 680K 50
C220	Electrolytic	CEA 100P 25
C221	Electrolytic	CEA 221P6R 3
C222	Electrolytic	CEA 100P 16
C223	Ceramic	CCDSL 680K 50
C224	Electrolytic	CEA 100P 25
C225	Electrolytic	CEA 100P 25
C226	Electrolytic	CEA 100P 25
C227	Electrolytic	CEA 100P 16
C228	Mylar	CQMA 332K 50
C229	Electrolytic	CEA 100P 25
C230	Electrolytic	CEA 330P 10
C231	Mylar	CQMA 102K 50
C232	Electrolytic	CEA 220P 25
C233	Electrolytic	CEA 220P 25
C234	Styrol	RCE-008
C235	Mylar	CQMA 272K 50
C236	Electrolytic	CSSA R33M 10
C237	Electrolytic	CSSA R47M 10
C238	Electrolytic	CEA 100P 25
C239	Electrolytic	CEA 100P 16
C240	Electrolytic	CEA 220P 10
C241	Mylar	CQMA 333K 50
C242	Mylar	CQMA 473K 50
C243	Mylar	CQMA 473K 50
C244	Electrolytic	CEA 2R2P 50
C245	Mylar	CQMA 103K 50
C301	Styrol	RCE-009
C302	Styrol	RCE-009
C303	Mylar	CQMA 333K 50
C304	Mylar	CQMA 103K 50
C305	Electrolytic	CEA 100P 25

Symbol	Description	Part No.
C306	Mylar	CQMA 333K 50
C307	Ceramic	CCDSL 101K 50
C308	Ceramic	CCDSL 101K 50
C309	Electrolytic	CEA 100P 25
C310	Electrolytic	CEA 100P 25
C313	Electrolytic	CEA 470P 25

RESISTORS

Symbol	Description	Part No.
--------	-------------	----------

R101	Carbon film	RD%VS 222J
R102	Carbon film	RD%VS 124J
R103	Carbon film	RD%VS 224J
R104	Carbon film	RD%VS 103J
R105	Carbon film	RD%VS 681J
R106	Carbon film	RD%VS 683J
R107	Carbon film	RD%VS 104J
R108	Carbon film	RD%VS 273J
R109	Carbon film	RD%VS 471J
R110	Carbon film	RD%VS 392J
R111	Carbon film	RD%VS 272J
R112	Carbon film	RD%VS 562J
R113	Carbon film	RD%VS 223J
R114	Carbon film	RD%VS 222J
R115	Carbon film	RD%VS 822J
R116	Carbon film	RD%VS 104J
R117	Carbon film	RD%VS 100J
R118	Carbon film	RD%VS 332J
R119	Carbon film	RD%VS 333J
R120	Carbon film	RD%VS 622J
R121	Carbon film	RD%VS 334J
R122	Carbon film	RD%VS 514J
R123	Carbon film	RD%VS 103J
R124	Carbon film	RD%VS 562J
R125	Carbon film	RD%VS 332J
R126	Carbon film	RD%VS 104J
R127	Carbon film	RD%VS 104J
R128	Carbon film	RD%VS 104J
R129	Carbon film	RD%VS 104J
R130	Carbon film	RD%VS 183J
R131	Carbon film	RD%VS 331J
R132	Carbon film	RD%VS 332J
R133	Carbon film	RD%VS 103J
R134	Carbon film	RD%VS 124J
R135	Carbon film	RD%VS 563J
R136	Carbon film	RD%VS 222J
R137	Carbon film	RD%VS 681J
R138	Carbon film	RD%VS 224J
R139	Carbon film	RD%VS 393J
R140	Carbon film	RD%VS 103J

Symbol	Description	Part No.
R141	Carbon film	RD%VS 332J
R142	Carbon film	RD%VS 332J
R143	Carbon film	RD%VS 102J
R144	Carbon film	RD%VS 124J
R145	Carbon film	RD%VS 274J
R146	Carbon film	RD%VS 392J
R147	Carbon film	RD%VS 154J
R148	Carbon film	RD%VS 272J
R149	Carbon film	RD%VS 272J
R150	Carbon film	RD%VS 273J
R151	Carbon film	RD%VS 153J
R152	Carbon film	RD%VS 221J
R153	Carbon film	RD%VS 152J
R154	Carbon film	RD%VS 332J
R155	Carbon film	RD%VS 683J
R156	Carbon film	RD%VS 102J
R157	Carbon film	RD%VS 102J
R158	Carbon film	RD%VS 471J
R159	Carbon film	RD%VS 471J
R160	Carbon film	RD%VS 153J
R161	Carbon film	RD%VS 473J
R162	Carbon film	RD%VS 102J
R163	Carbon film	RD%VS 333J
R164	Vacancy
R165	Carbon film	RD%VS 222J
R166	Carbon film	RD%VS 682J
R167	Carbon film	RD%VS 102J
R168	Carbon film	RD%VS 103J
R169	Carbon film	RD%VS 272J
R170	Carbon film	RD%VS 683J
R171	Carbon film	RD%VS 103J
R172	Carbon film	RD%VS 472J
R173	Carbon film	RD%VS 102J
R174	Carbon film	RD%VS 223J
R175	Carbon film	RD%VS 560J
R176	Carbon film	RD%VS 102J
R177	Carbon film	RD%VS 330J
R178	Carbon film	RD%VS 152J
R179	Carbon film	RD%VS 272J
R180	Carbon film	RD%VS 102J
R181	Carbon film	RD%VS 472J
R182	Carbon film	RD%VS 183J
R183	Carbon film	RD%VS 914J
R184	Carbon film	RD%VS 682J
R185	Carbon film	RD%VS 472J
R186	Carbon film	RD%VS 472J
R187	Carbon film	RD%VS 472J
R188	Carbon film	RD%VS 332J
R189	Carbon film	RD%VS 332J
R190	Carbon film	RD%VS 332J

Symbol	Description	Part No.
R191	Carbon film 10k	RD%VS 103J
R192	Carbon film 1k	RD%VS 102J
R193	Carbon film 470	RD%VS 471J
R201	Carbon film 2.2k	RD%VS 222J
R202	Carbon film 120k	RD%VS 124J
R203	Carbon film 220k	RD%VS 224J
R204	Carbon film 10k	RD%VS 103J
R205	Carbon film 680	RD%VS 681J
R206	Carbon film 68k	RD%VS 683J
R207	Carbon film 100k	RD%VS 104J
R208	Carbon film 27k	RD%VS 273J
R209	Carbon film 470	RD%VS 471J
R210	Carbon film 3.9k	RD%VS 392J
R211	Carbon film 2.7k	RD%VS 272J
R212	Carbon film 5.6k	RD%VS 562J
R213	Carbon film 22k	RD%VS 223J
R214	Carbon film 2.2k	RD%VS 222J
R215	Carbon film 8.2k	RD%VS 822J
R216	Carbon film 100k	RD%VS 104J
R217	Carbon film 10	RD%VS 100J
R218	Carbon film 3.3k	RD%VS 332J
R219	Carbon film 33k	RD%VS 333J
R220	Carbon film 6.2k	RD%VS 622J
R221	Carbon film 330k	RD%VS 334J
R222	Carbon film 510k	RD%VS 514J
R223	Carbon film 10k	RD%VS 103J
R224	Carbon film 5.6k	RD%VS 562J
R225	Carbon film 3.3k	RD%VS 332J
R226	Carbon film 100k	RD%VS 104J
R227	Vacancy
R228	Carbon film 100k	RD%VS 104J
R229	Vacancy
R230	Carbon film 18k	RD%VS 183J
R231	Carbon film 330	RD%VS 331J
R232	Carbon film 3.3k	RD%VS 332J
R233	Carbon film 10k	RD%VS 103J
R234	Carbon film 120k	RD%VS 124J
R235	Carbon film 56k	RD%VS 563J
R236	Carbon film 2.2k	RD%VS 222J
R237	Carbon film 680	RD%VS 681J
R238	Carbon film 220k	RD%VS 224J
R239	Carbon film 39k	RD%VS 393J
R240	Carbon film 10k	RD%VS 103J
R241	Carbon film 3.3k	RD%VS 332J
R242	Carbon film 3.3k	RD%VS 332J
R243	Carbon film 1k	RD%VS 102J
R244	Carbon film 120k	RD%VS 124J
R245	Carbon film 270k	RD%VS 274J
R246	Carbon film 3.9k	RD%VS 392J
R247	Carbon film 150k	RD%VS 154J
R248	Carbon film 2.7k	RD%VS 272J

Symbol	Description	Part No.
R249	Carbon film 2.7k	RD%VS 272J
R250	Carbon film 27k	RD%VS 273J
R251	Carbon film 15k	RD%VS 153J
R252	Carbon film 220	RD%VS 221J
R253	Carbon film 1.5k	RD%VS 152J
R254	Carbon film 3.3k	RD%VS 332J
R255	Carbon film 68k	RD%VS 683J
R256	Carbon film 1k	RD%VS 102J
R257	Carbon film 1k	RD%VS 102J
R258	Carbon film 470	RD%VS 471J
R259	Carbon film 470	RD%VS 471J
R260	Carbon film 15k	RD%VS 153J
R261	Carbon film 47k	RD%VS 473J
R262	Carbon film 1k	RD%VS 102J
R263	Carbon film 33k	RD%VS 333J
R264	Vacancy
R265	Carbon film 2.2k	RD%VS 222J
R266	Carbon film 6.8k	RD%VS 682J
R267	Carbon film 1k	RD%VS 102J
R268	Carbon film 10k	RD%VS 103J
R269	Carbon film 2.7k	RD%VS 272J
R270	Carbon film 68k	RD%VS 683J
R271	Carbon film 10k	RD%VS 103J
R272	Carbon film 4.7k	RD%VS 472J
R273	Carbon film 1k	RD%VS 102J
R274	Carbon film 22k	RD%VS 223J
R275	Carbon film 56	RD%VS 560J
R276	Carbon film 1k	RD%VS 102J
R277	Carbon film 33	RD%VS 330J
R278	Carbon film 1.5k	RD%VS 152J
R279	Carbon film 2.7k	RD%VS 272J
R280	Carbon film 1k	RD%VS 102J
R281	Carbon film 4.7k	RD%VS 472J
R282	Carbon film 18k	RD%VS 183J
R283	Carbon film 910k	RD%VS 914J
R284	Carbon film 6.8k	RD%VS 682J
R285	Carbon film 4.7k	RD%VS 472J
R286	Carbon film 4.7k	RD%VS 472J
R287	Carbon film 4.7k	RD%VS 472J
R288	Carbon film 3.3k	RD%VS 332J
R289	Carbon film 3.3k	RD%VS 332J
R290	Carbon film 3.3k	RD%VS 332J
R291	Carbon film 10k	RD%VS 103J
R292	Carbon film 1k	RD%VS 102J
R293	Carbon film 470	RD%VS 471J
R301	Carbon film 4.3k	RD%VS 432J
R302	Carbon film 1k	RD%VS 102J
R303	Carbon film 33	RD%VS 330J
R304	Carbon film 2.2k	RD%VS 222J
R305	Vacancy

Symbol	Description	Part No.
R306	Carbon film 470k	RD%VS 474J
R307	Metal oxide 1k 1W	RS1PSF 102J
R316	Carbon film 3.3k	RD%VS 332J
R317	Carbon film 8.2k	RD%VS 822J
VR102	Semi-fixed 22k-B	C92-857
VR104	Semi-fixed 10k-B	C92-049
VR106	Semi-fixed 10k-B	C92-049
VR107	Semi-fixed 15k-B	RCP-006
VR202	Semi-fixed 22k-B	C92-857
VR204	Semi-fixed 10k-B	C92-049
VR206	Semi-fixed 10k-B	C92-049
VR207	Semi-fixed 15k-B	RCP-006
VR301	Semi-fixed 220k-B	RCP-005
VR302	Semi-fixed 220k-B	RCP-005

SEMICONDUCTORS

Symbol	Description	Part No.
Q101	Transistor 2SC1327-T or U	
Q102	Transistor 2SC1327-T or U	
Q103	Transistor 2SC1327-T or U	
Q104	Transistor 2SC1327-T or U	
Q105	Transistor 2SC1327-T or U	
Q106	Transistor 2SC828 (H) -R or S	
Q107	Transistor 2SC828 (H) -R or S	
Q108	Transistor 2SC828 (H) -R or S	
Q109	Transistor 2SC828 (H) -R or S	
Q110	Transistor 2SC828 (H) -R or S	
Q111	Transistor 2SC828 (H) -R or S	
Q112	Transistor 2SC828 (H) -R or S	
Q113	Transistor 2SC828 (H) -R or S	
Q114	Transistor 2SC828 (H) -R or S	
Q115	Transistor 2SC828 (H) -R or S	
Q116	Transistor 2SC828 (H) -R or S	
Q117	Transistor 2SC828 (H) -R or S	
Q118	Transistor 2SA564-R or S	
Q119	FET 2SK30A-0 or Y	
Q120	FET 2SK30A-0 or Y	
Q201	Transistor 2SC1327-T or U	
Q202	Transistor 2SC1327-T or U	
Q203	Transistor 2SC1327-T or U	
Q204	Transistor 2SC1327-T or U	
Q205	Transistor 2SC1327-T or U	
Q206	Transistor 2SC828 (H) -R or S	
Q207	Transistor 2SC828 (H) -R or S	
Q208	Transistor 2SC828 (H) -R or S	
Q209	Transistor 2SC828 (H) -R or S	
Q210	Transistor 2SC828 (H) -R or S	
Q211	Transistor 2SC828 (H) -R or S	
Q212	Transistor 2SC828 (H) -R or S	
Q213	Transistor 2SC828 (H) -R or S	

Symbol	Description	Part No.
Q214	Transistor 2SC828 (H) -R or S	
Q215	Transistor 2SC828 (H) -R or S	
Q216	Transistor 2SC828 (H) -R or S	
Q217	Transistor 2SC828 (H) -R or S	
Q218	Transistor 2SA564-R or S	
Q219	FET 2SK30A-0 or Y	
Q220	FET 2SK30A-0 or Y	
Q301	Transistor 2SC735-Y	
Q302	Transistor 2SC735-Y	
D101	Diode 1S2473VE	
D102	Diode 1S2473VE	
D103	Diode 1N60	
D104	Diode 1N60	
D105	Diode 1S2473VE	
D201	Diode 1S2473VE	
D202	Diode 1S2473VE	
D203	Diode 1N60	
D204	Diode 1N60	
D205	Diode 1S2473VE	
D206	Diode 1S2473VE	
D207	Diode 1S2473VE	
D303	Diode 1S2473VE	

OTHERS

Symbol	Description	Part No.
	REC/PB selector switch (S1)	RSH-011
T101	Matching coil	T61-408
T201	Matching coil	T61-408
L101	Trap coil	T84-401
L102	Trap coil	T84-401
L103	Peaking coil	RTF-001
L104	Peaking coil	RTF-007
L201	Trap coil	T84-401
L202	Trap coil	T84-401
L203	Peaking coil	RTF-001
L204	Peaking coil	RTF-007
L301	Oscillator coil	T64-001

11.3 INDICATOR ASSEMBLY (RWX-081)

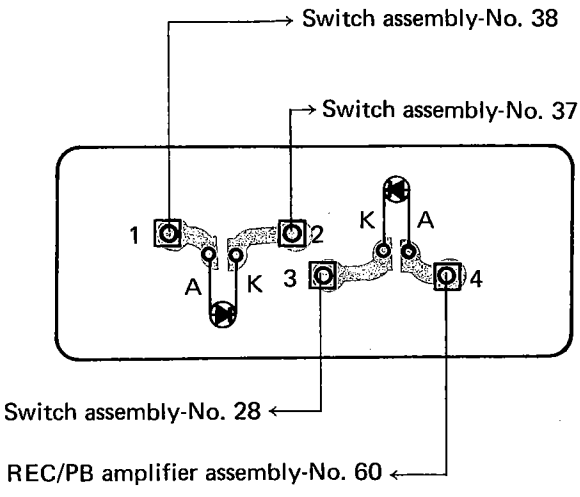
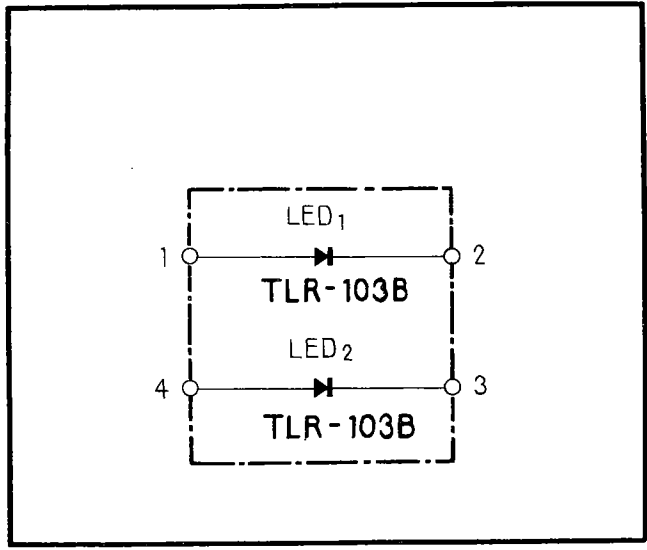

Parts List of Indicator Assembly (RWX-081)

SEMICONDUCTORS

Symbol	Description	Part No.
LED1	Light emitting diode TLR-103-B	
LED2	Light emitting diode TLR-103-B	

11.4 CONNECTOR ASSEMBLY (RWX-084)

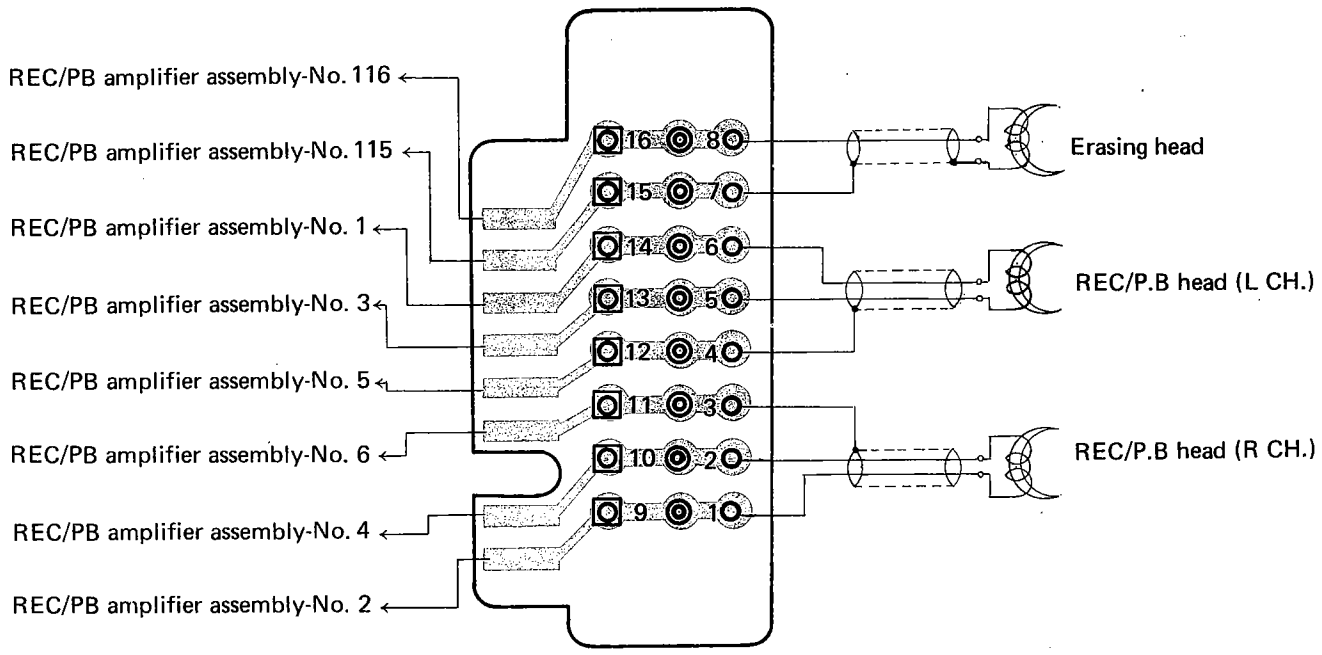

11.5 DOLBY PROCESSOR ASSEMBLY (RWX-078)

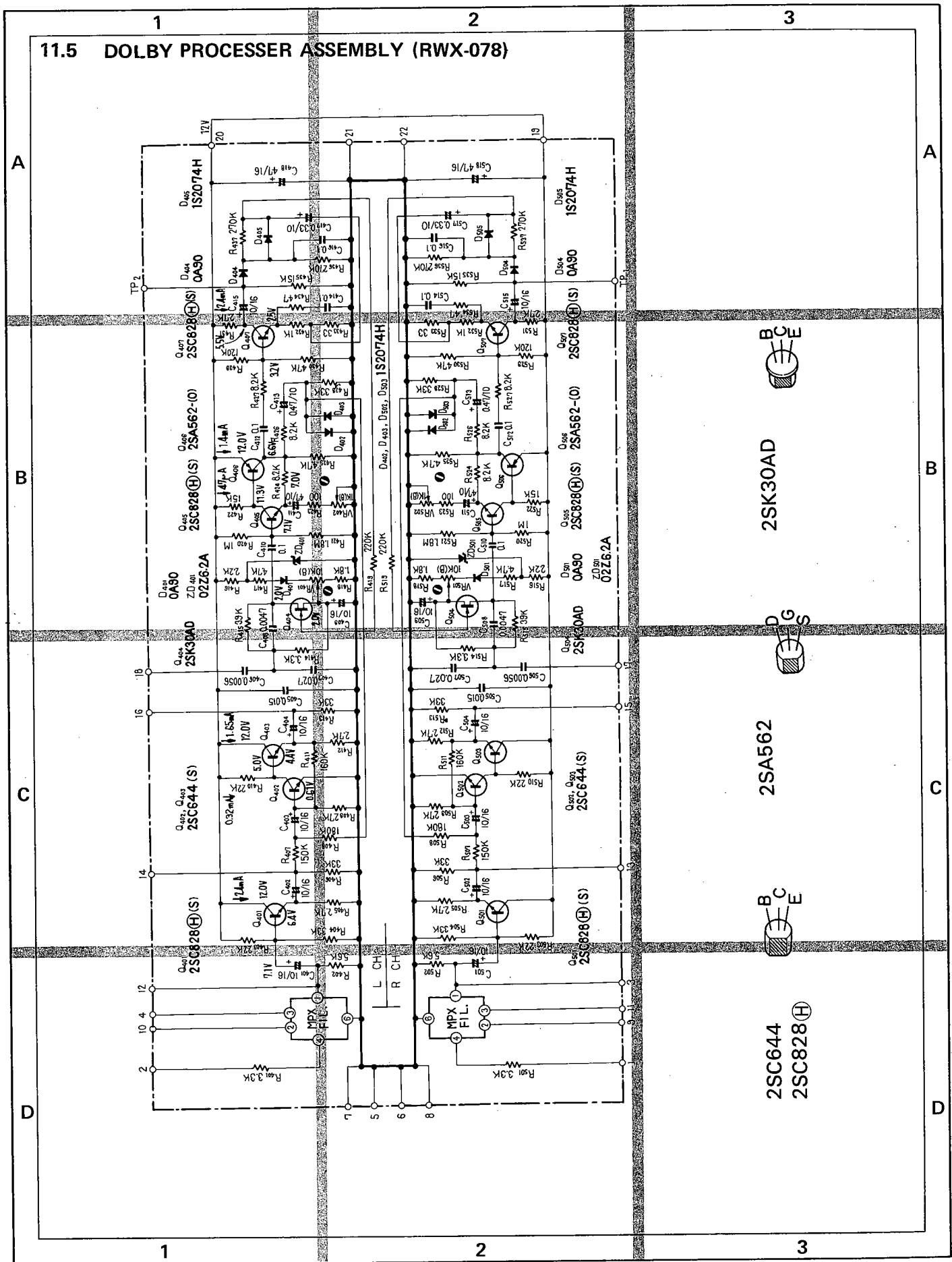

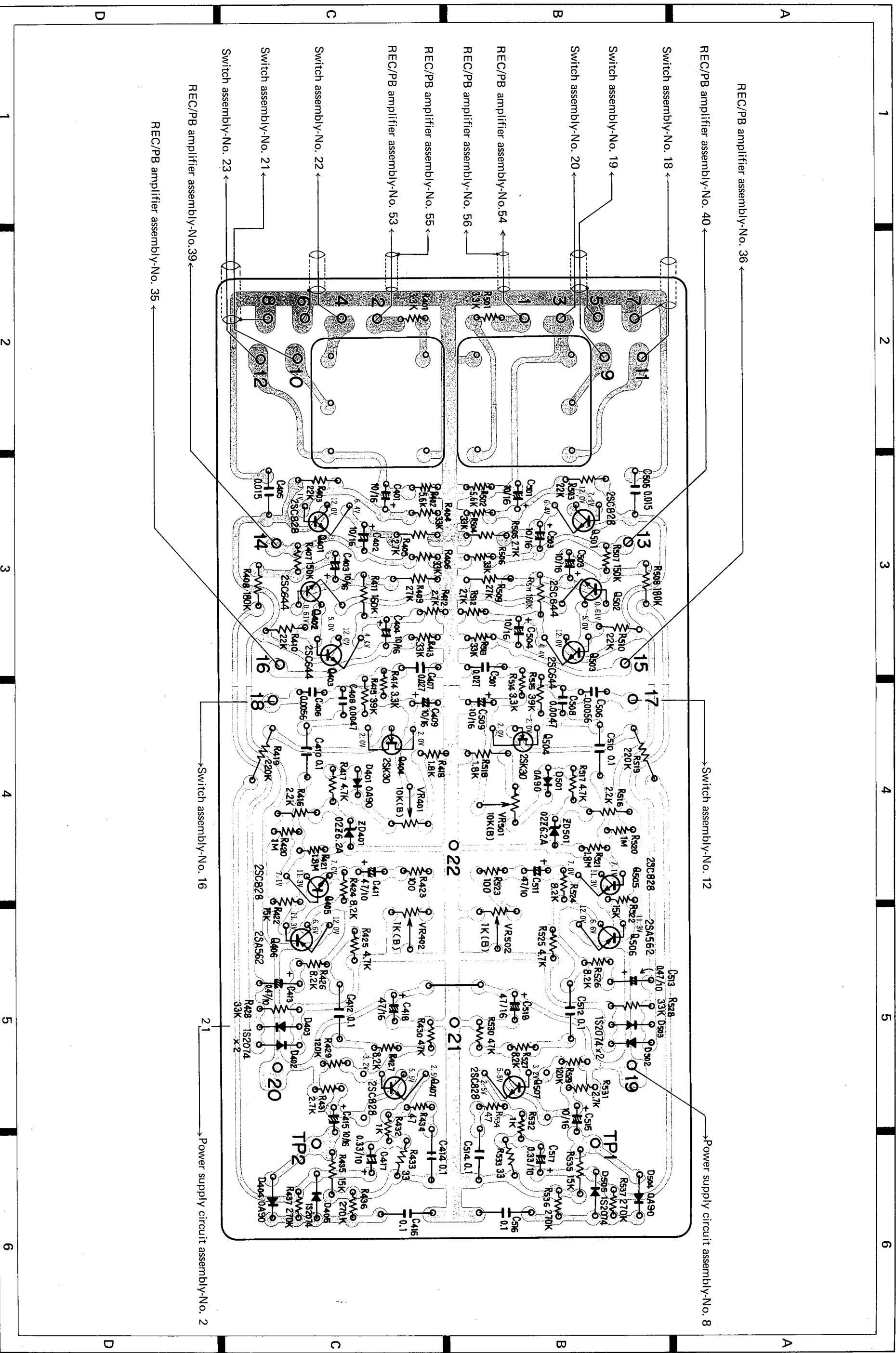

List of Dolby Processor Assembly (RWX-078)

CITORS

Symbol	Description	Part No.
01	Electrolytic 10 16V	CEA 100P 16
02	Electrolytic 10 16V	CEA 100P 16
03	Electrolytic 10 16V	CEA 100P 16
04	Electrolytic 10 16V	CEA 100P 16
05	Mylar 0.015 50V	COMA 153K 50
06	Mylar 0.0056 50V	COMA 562K 50
07	Mylar 0.027 50V	COMA 273K 50
08	Mylar 0.0047 50V	COMA 472K 50
09	Electrolytic 10 16V	CEA 100P 16
10	Mylar 0.1 50V	COMA 104K 50
11	Electrolytic 47 10V	CEA 470P 10
12	Mylar 0.1 50V	COMA 104K 50
13	Electrolytic 0.47 10V	CSSA R47M 10
14	Mylar 0.1 50V	COMA 104K 50
15	Electrolytic 10 16V	CEA 100P 16
16	Mylar 0.1 50V	COMA 104K 50
17	Electrolytic 0.33 10V	CSSA R33M 10
18	Electrolytic 47 16V	CEA 470P 16
01	Electrolytic 10 16V	CEA 100P 16
02	Electrolytic 10 16V	CEA 100P 16
03	Electrolytic 10 16V	CEA 100P 16
04	Electrolytic 10 16V	CEA 100P 16
05	Mylar 0.015 50V	COMA 153K 50
06	Mylar 0.0056 50V	COMA 562K 50
07	Mylar 0.027 50V	COMA 273K 50
08	Mylar 0.0047 50V	COMA 472K 50
09	Electrolytic 10 16V	CEA 100P 16
10	Mylar 0.1 50V	COMA 104K 50
11	Electrolytic 47 10V	CEA 470P 10
12	Mylar 0.1 50V	COMA 104K 50
13	Electrolytic 0.47 10V	CSSA R47M 10
14	Mylar 0.1 50V	COMA 104K 50
15	Electrolytic 10 16V	CEA 100P 16
16	Mylar 0.1 50V	COMA 104K 50
17	Electrolytic 0.33 10V	CSSA R33M 10
18	Electrolytic 47 16V	CEA 470P 16

STORS

Symbol	Description	Part No.
01	Carbon film 3.3k	RD%VS 332J
02	Carbon film 5.6k	RD%VS 562J
03	Carbon film 22k	RD%VS 223J
04	Carbon film 33k	RD%VS 333J
05	Carbon film 2.7k	RD%VS 272J
06	Carbon film 33k	RD%VS 333J
07	Carbon film 150k	RD%VS 154J
08	Carbon film 180k	RD%VS 184J

Symbol	Description	Part No.
R409	Carbon film 27k	RD%VS 273J
R410	Carbon film 22k	RD%VS 223J
R411	Carbon film 160k	RD%VS 164J
R412	Carbon film 2.7k	RD%VS 272J
R413	Carbon film 33k	RD%VS 333J
R414	Carbon film 3.3k	RD%VS 332J
R415	Carbon film 39k	RD%VS 393J
R416	Carbon film 2.2k	RD%VS 222J
R417	Carbon film 4.7k	RD%VS 472J
R418	Carbon film 1.8k	RD%VS 182J
R419	Carbon film 220k	RD%VS 224J
R420	Carbon film 1M	RD%VS 105J
R421	Carbon film 1.8M	RD%VS 185J
R422	Carbon film 15k	RD%VS 153J
R423	Carbon film 100	RD%VS 101J
R424	Carbon film 8.2k	RD%VS 822J
R425	Carbon film 4.7k	RD%VS 472J
R426	Carbon film 8.2k	RD%VS 822J
R427	Carbon film 8.2k	RD%VS 822J
R428	Carbon film 33k	RD%VS 333J
R429	Carbon film 120k	RD%VS 124J
R430	Carbon film 47k	RD%VS 473J
R431	Carbon film 2.7k	RD%VS 272J
R432	Carbon film 1k	RD%VS 102J
R433	Carbon film 33	RD%VS 330J
R434	Carbon film 47	RD%VS 470J
R435	Carbon film 15k	RD%VS 153J
R436	Carbon film 270k	RD%VS 274J
R437	Carbon film 270k	RD%VS 274J
R501	Carbon film 3.3k	RD%VS 332J
R502	Carbon film 5.6k	RD%VS 562J
R503	Carbon film 22k	RD%VS 223J
R504	Carbon film 33k	RD%VS 333J
R505	Carbon film 2.7k	RD%VS 272J
R506	Carbon film 33k	RD%VS 333J
R507	Carbon film 150k	RD%VS 154J
R508	Carbon film 180k	RD%VS 184J
R509	Carbon film 27k	RD%VS 273J
R510	Carbon film 22k	RD%VS 223J
R511	Carbon film 160k	RD%VS 164J
R512	Carbon film 2.7k	RD%VS 272J
R513	Carbon film 33k	RD%VS 333J
R514	Carbon film 3.3k	RD%VS 332J
R515	Carbon film 39k	RD%VS 393J
R516	Carbon film 2.2k	RD%VS 222J
R517	Carbon film 4.7k	RD%VS 472J
R518	Carbon film 1.8k	RD%VS 182J
R519	Carbon film 220k	RD%VS 224J
R520	Carbon film 1M	RD%VS 105J

Symbol	Description	Part No.
R521	Carbon film 1.8M	RD%VS 185J
R522	Carbon film 15k	RD%VS 153J
R523	Carbon film 100	RD%VS 101J
R524	Carbon film 8.2k	RD%VS 822J
R525	Carbon film 4.7k	RD%VS 472J
R526	Carbon film 8.2k	RD%VS 822J
R527	Carbon film 8.2k	RD%VS 822J
R528	Carbon film 33k	RD%VS 333J
R529	Carbon film 120k	RD%VS 124J
R530	Carbon film 47k	RD%VS 473J
R531	Carbon film 2.7k	RD%VS 272J
R532	Carbon film 1k	RD%VS 102J
R533	Carbon film 33	RD%VS 330J
R534	Carbon film 47	RD%VS 470J
R535	Carbon film 15k	RD%VS 153J
R536	Carbon film 270k	RD%VS 274J
R537	Carbon film 270k	RD%VS 274J
VR401	Semi-fixed 10k-B	C92-049
VR402	Semi-fixed 1k-B	C92-404
VR501	Semi-fixed 10k-B	C92-049
VR502	Semi-fixed 1k-B	C92-404

SEMICONDUCTORS

Symbol	Description	Part No.
O401	Transistor 2SC828 (H)-S	
O402	Transistor 2SC644-S	
O403	Transistor 2SC644-S	
O404	FET 2SK30AD	
O405	Transistor 2SC828 (H)-S	
O406	Transistor 2SA562-O	
O407	Transistor 2SC828 (H)-S	
O501	Transistor 2SC828 (H)-S	
O502	Transistor 2SC644-S	
O503	Transistor 2SC644-S	
O504	FET 2SK30AD	
O505	Transistor 2SC828 (H)-S	
O506	Transistor 2SA562-O	
O507	Transistor 2SC828 (H)-S	
D401	Diode OA90	
D402	Diode 1S2074H	
D403	Diode 1S2074H	
D404	Diode OA90	
D405	Diode 1S2074H	
D501	Diode OA90	
D502	Diode 1S2074H	
D503	Diode 1S2074H	
D504	Diode OA90	
D505	Diode 1S2074H	

Symbol	Description	Part No.
ZD401	Zener diode 02Z6.2A	
ZD501	Zener diode 02Z6.2A	

OTHERS

Symbol	Description	Part No.
	MPX coil block	RTF-012

11.6 FUSE ASSEMBLY (RWX-080)

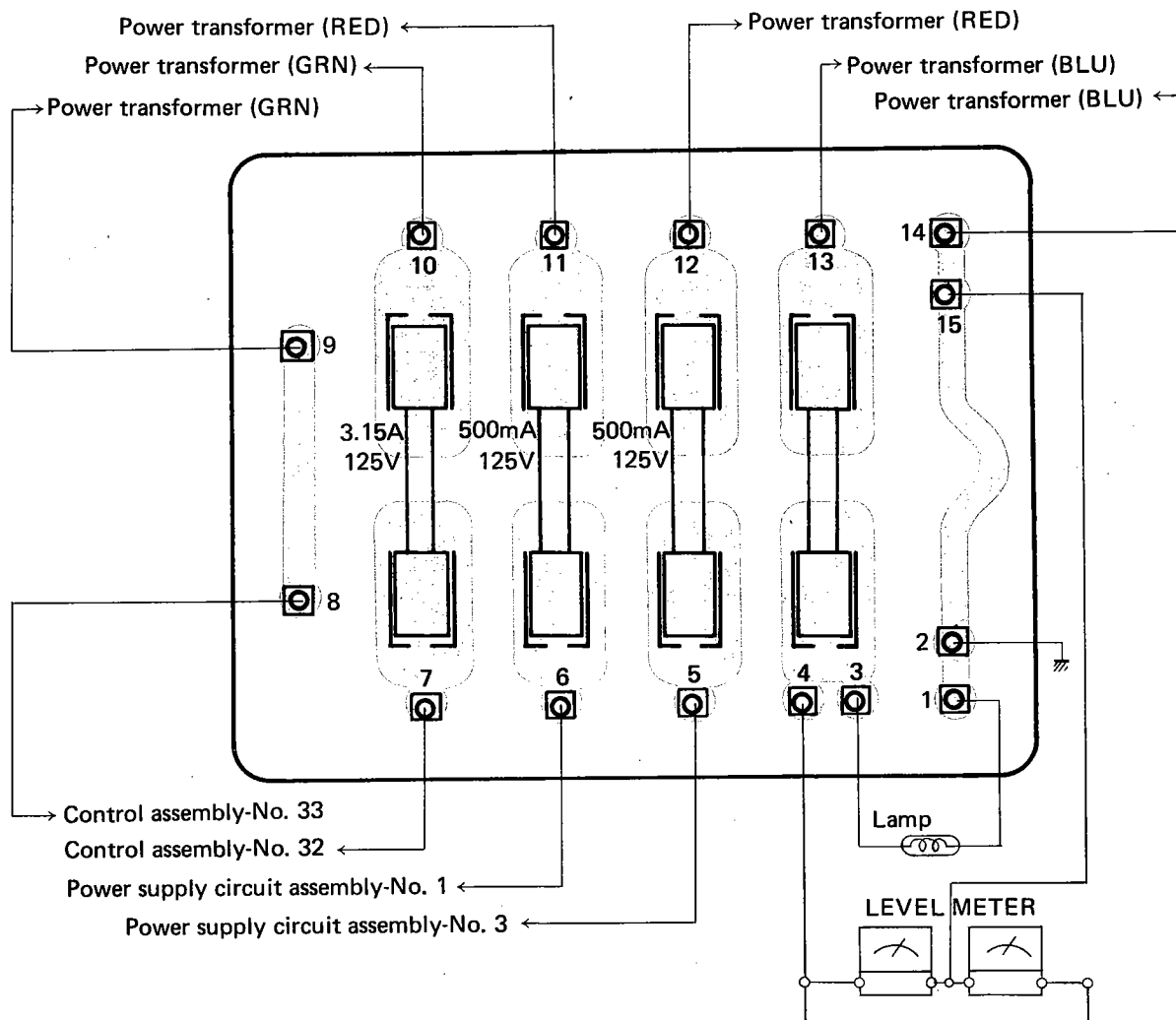

Parts List of Fuse Assembly (RWX-080)

CAPACITORS

Symbol	Description	Part No.
	Fuse clip	RKR-017
	Fuse 500mA	REK-048
	Fuse 3.15A (Surge proof)	REK-044

11.7 CONTROL ASSEMBLY (RWG-048)

NOTE: The voltage values in circuit diagram are expressed on page 70.

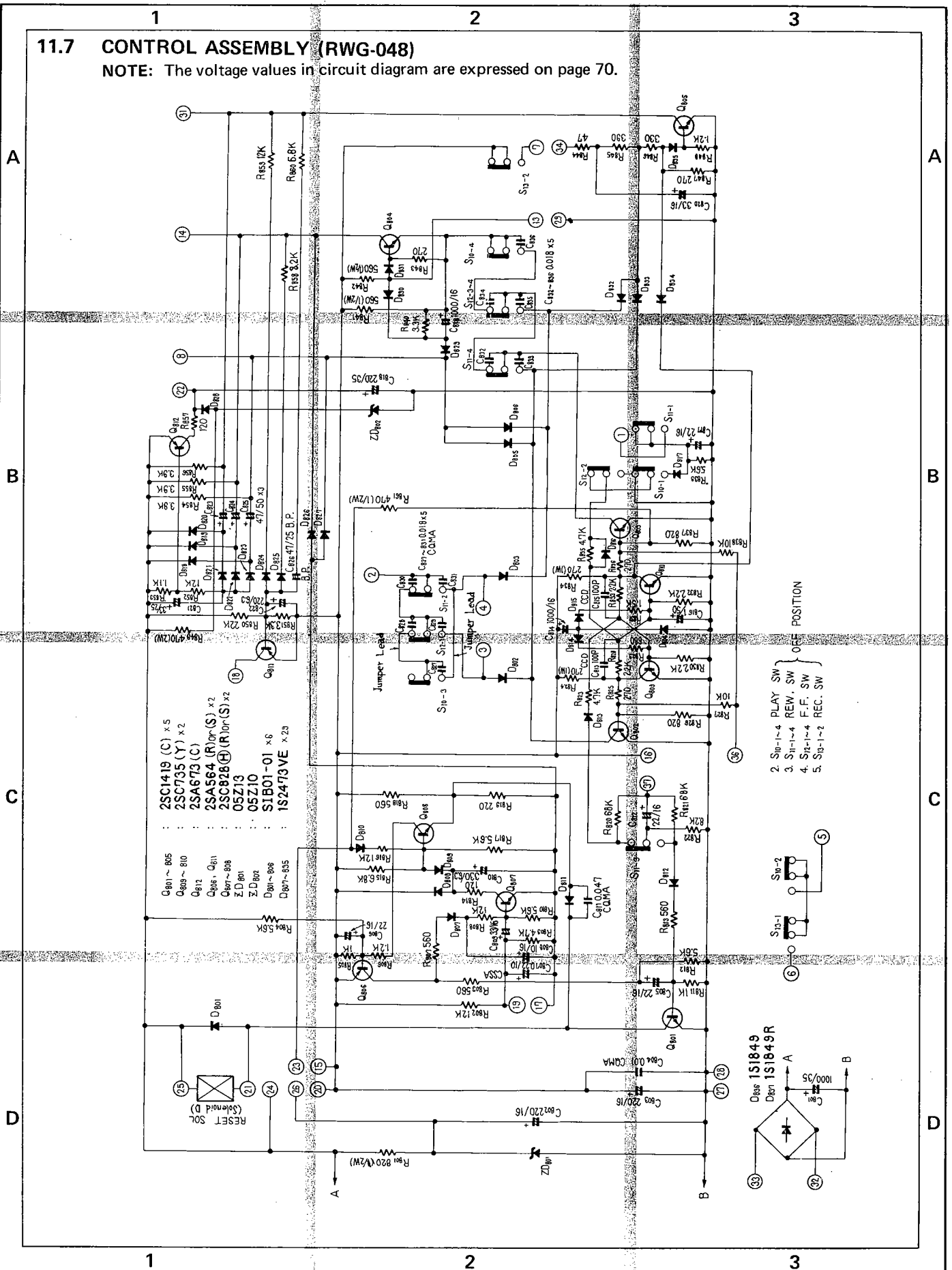

- Q101 ~ 805
- C101 ~ 810
- Q112
- 2SA564 (R) or (S) x 2
- 2SC828 (H) (R) or (S) x 2
- 05Z13
- 05Z10
- S1B01-01 x 6
- 1S2473VE x 23

- 2. S10-1-4 PLAY SW
- 3. S11-1-4 REV. SW
- 4. S12-1-4 F.F. SW
- 5. S13-1-2 REC. SW

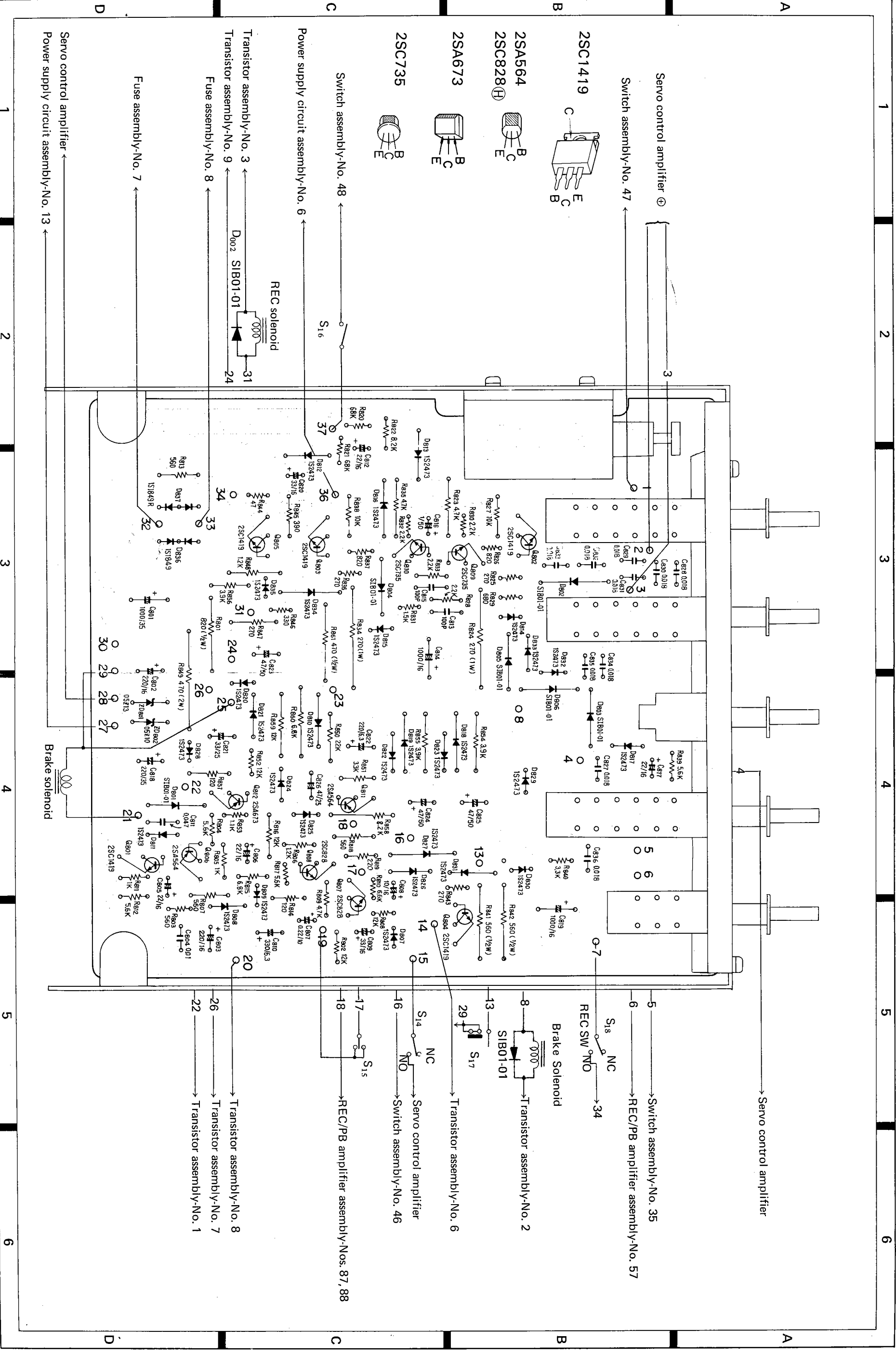

1 2 3 4 5 6

A B C D

Servo control amplifier

Switch assembly-No. 35

REC/PB amplifier assembly-No. 57

S18 NC

34

Brake Solenoid

Transistor assembly-No. 2

SIB01-01

Transistor assembly-No. 6

S17

Servo control amplifier

Switch assembly-No. 46

S14 NO

S15

REC/PB amplifier assembly-Nos. 87, 88

S16

REC solenoid

31

D002 SIB01-01

Transistor assembly-No. 3

Transistor assembly-No. 9

Transistor assembly-No. 8

Transistor assembly-No. 1

24

Fuse assembly-No. 7

26

Transistor assembly-No. 7

Transistor assembly-No. 1

22

Power supply circuit assembly-No. 13

Servo control amplifier

1 2 3 4 5 6

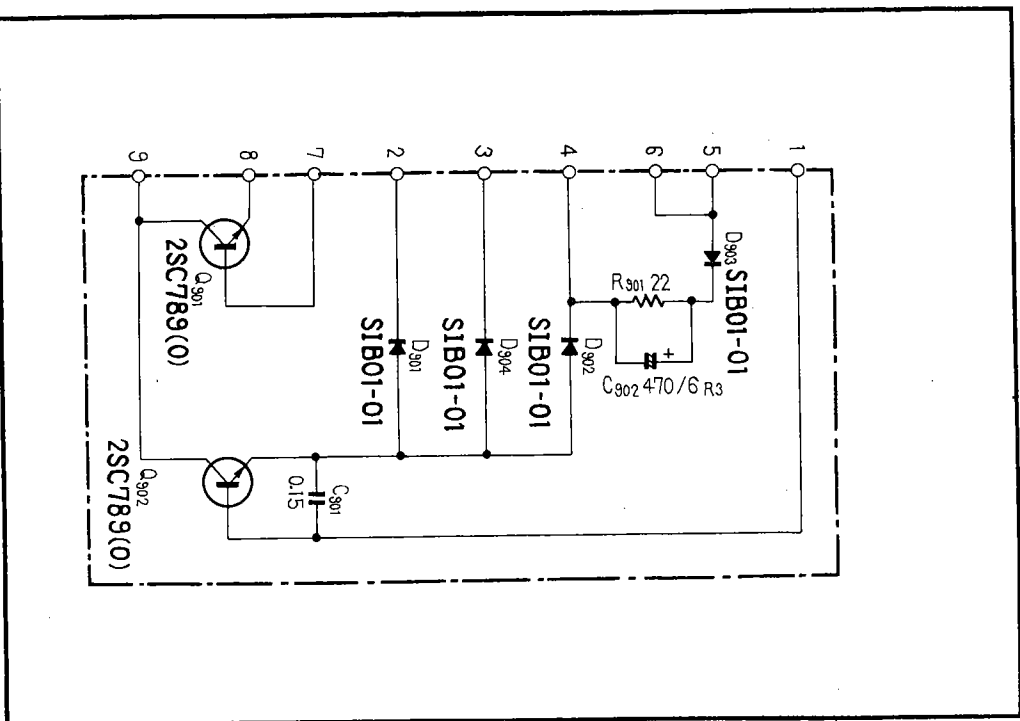

Parts List of Transistor Assembly (RWX-083)

CAPACITORS

Symbol	Description	Part No.
C901	Mylar 0.15 50V	COMA 154K 50
C902	Electrolytic 470 6.3V	CEA 471P 6R3

RESISTORS

Symbol	Description	Part No.
R901	Carbon film 22	RD%VS 220J

SEMICONDUCTORS

Symbol	Description	Part No.
D901	Diode SIB01-01	
R902	Diode SIB01-01	
R903	Diode SIB01-01	
R904	Diode SIB01-01	
Q901	Transistor 2SC789-0	
Q902	Transistor 2SC789-0	

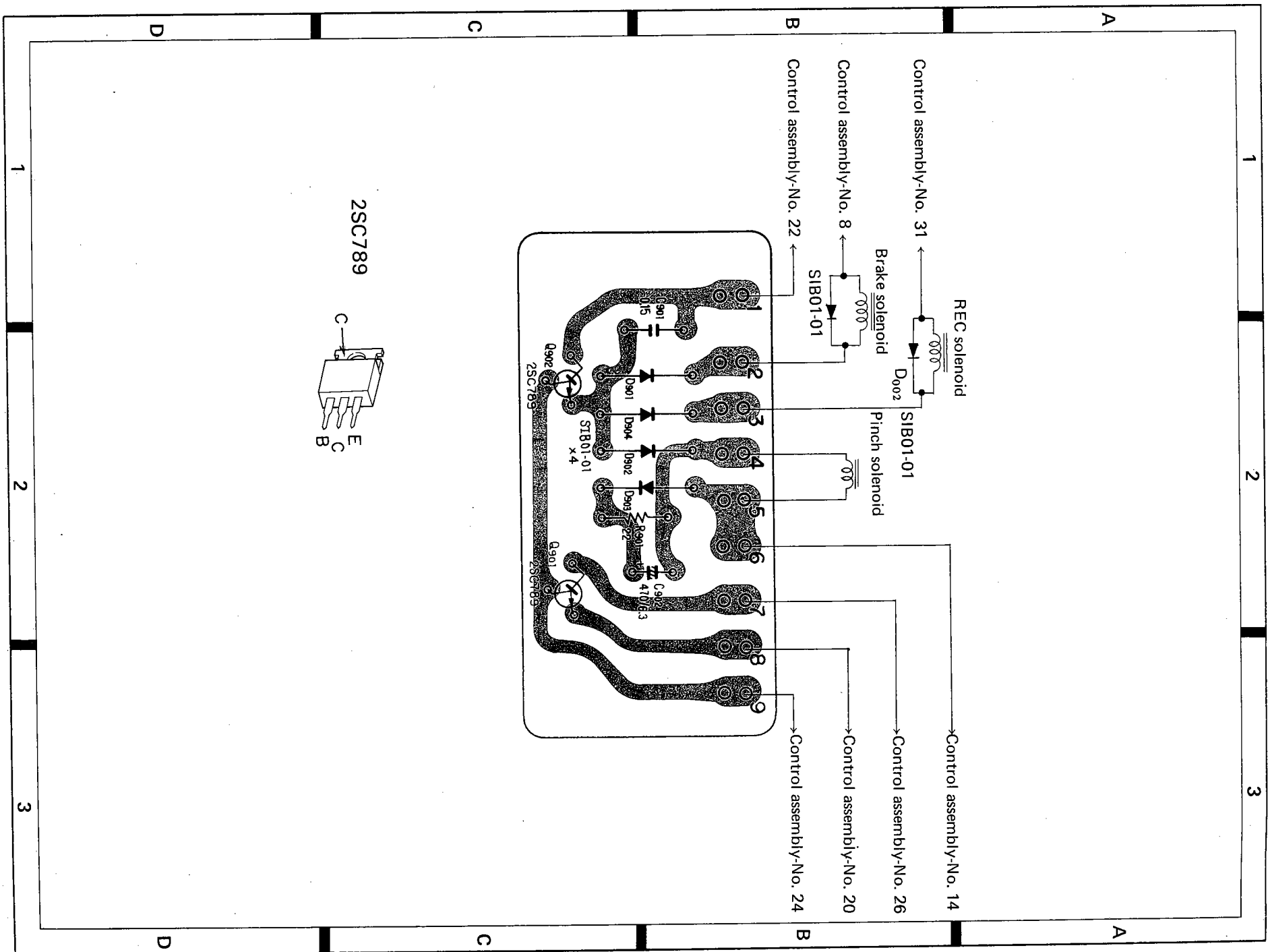

9 SWITCH ASSEMBLY (RMS-031)

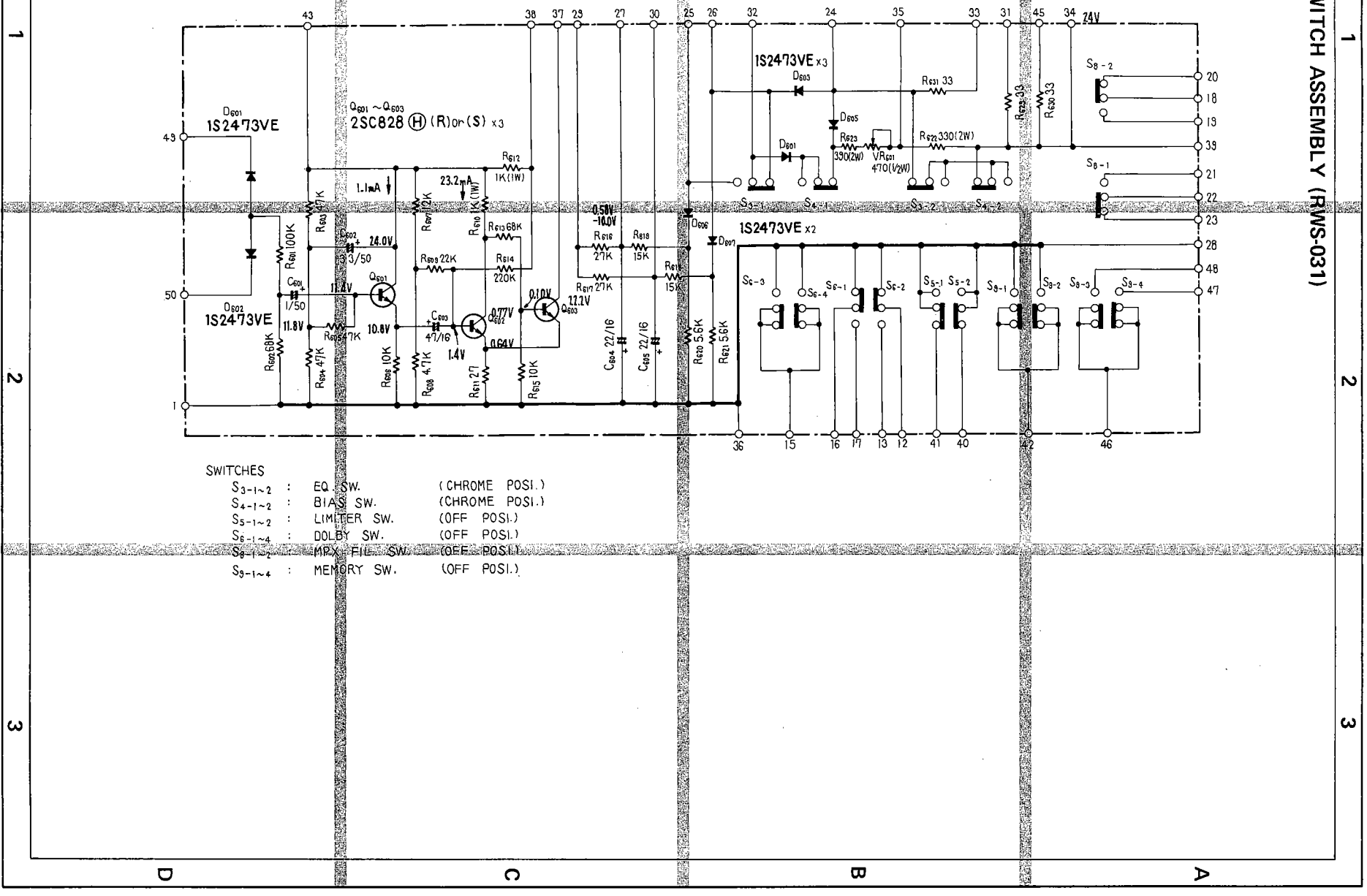

- SWITCHES
- S₃₋₁₋₂ : EQ SW. (CHROME POSI.)
 - S₄₋₁₋₂ : BIAS SW. (CHROME POSI.)
 - S₅₋₁₋₂ : LIMITER SW. (OFF POSI.)
 - S₆₋₁₋₂ : DOLBY SW. (OFF POSI.)
 - S₇₋₁₋₂ : MPX FIL SW. (OFF POSI.)
 - S₈₋₁₋₄ : MEMORY SW. (OFF POSI.)

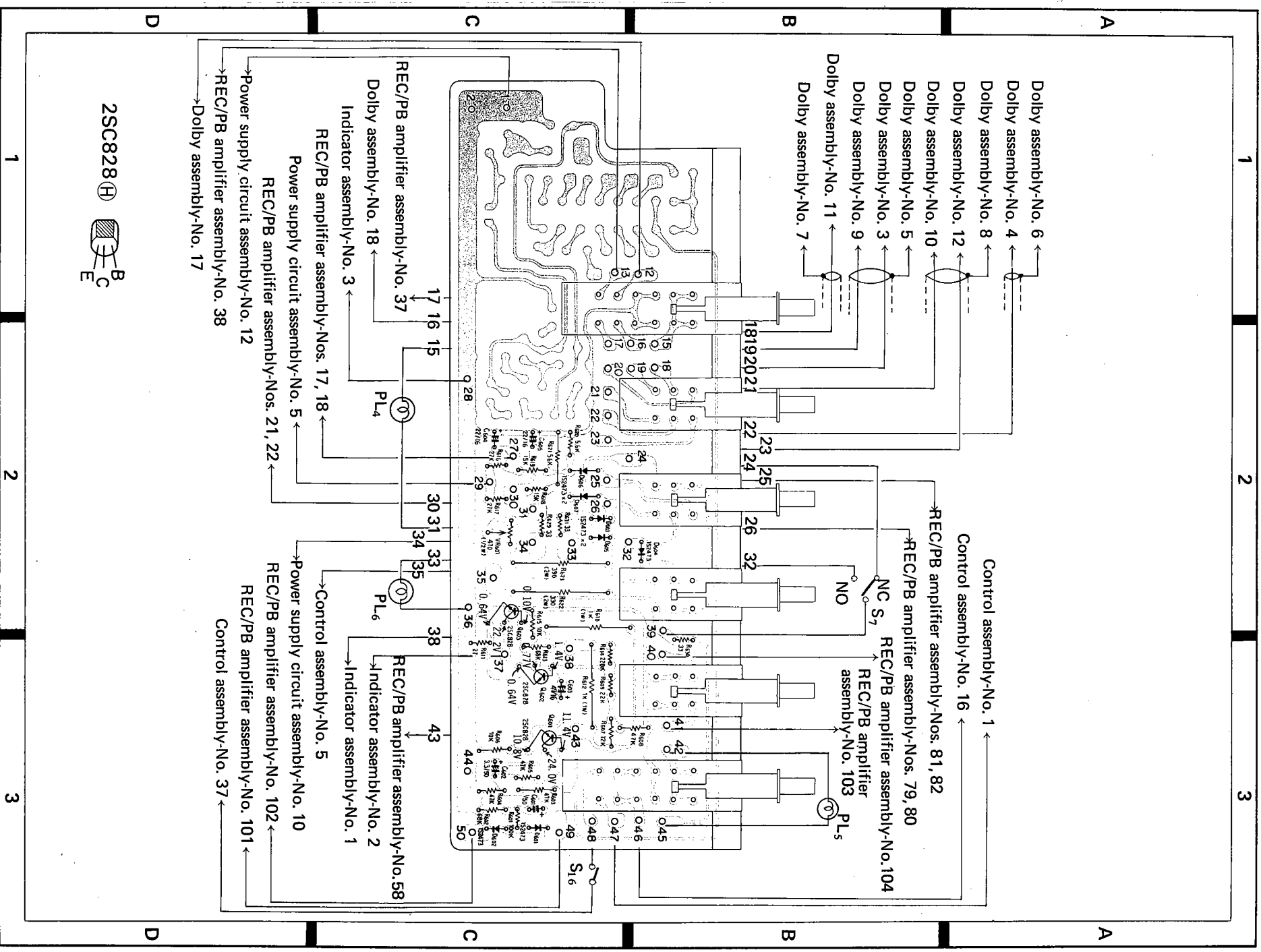

Parts List of Switch Assembly (RWS-031)

CAPACITORS

Symbol	Description	Part No.
C601	Electrolytic 1 50V	CEA 010P 50
C602	Electrolytic 3.3 50V	CEA 3R3P 50
C603	Electrolytic 47 16V	CEA 470P 16
C604	Electrolytic 22 16V	CEA 220P 16
C605	Electrolytic 22 16V	CEA 220P 16

Symbol	Description	Part No.
D606	Diode 1S2473VE	
D607	Diode 1S2473VE	

RESISTORS

Symbol	Description	Part No.
R601	Carbon film 100k	RD¼VS 104J
R602	Carbon film 68k	RD¼VS 683J
R603	Carbon film 47k	RD¼VS 473J
R604	Carbon film 47k	RD¼VS 473J
R605	Carbon film 47k	RD¼VS 473J
R606	Carbon film 10k	RD¼VS 103J
R607	Carbon film 12k	RD¼VS 123J
R608	Carbon film 4.7k	RD¼VS 472J
R609	Carbon film 22k	RD¼VS 223J
R610	Metal oxide 1k	RS1PSF 102J
R611	Carbon film 27	RD¼VS 270J
R612	Metal oxide-film 1k	RS1PSF 102J
R613	Carbon film 68k	RD¼VS 683J
R614	Carbon film 220k	RD¼VS 224J
R615	Carbon film 10k	RD¼VS 103J
R616	Carbon film 27k	RD¼VS 273J
R617	Carbon film 27k	RD¼VS 273J
R618	Carbon film 15k	RD¼VS 153J
R619	Carbon film 15k	RD¼VS 153J
R620	Carbon film 5.6k	RD¼VS 562J
R621	Carbon film 5.6k	RD¼VS 562J
R622	Metal oxide 330 2W	RS2P 331J
R623	Metal oxide 390 2W	RS2P 391J
R629	Carbon film 33	RD¼VS 330J
R630	Carbon film 33	RD¼VS 330J
R631	Carbon film 33	RD¼VS 330J
VR601	Semi-fixed 470 (½W)	RCP-022

SWITCHES

Symbol	Description	Part No.
S ₃ , S ₄ , S ₅ S ₆ , S ₈ , S ₉	Push switch assembly	RSG-029

SEMICONDUCTORS

Symbol	Description	Part No.
Q601	Transistor 2SC828 (H) -R or S	
Q602	Transistor 2SC828 (H) -R or S	
Q603	Transistor 2SC828 (H) -R or S	
D601	Diode 1S2473VE	
D602	Diode 1S2473VE	
D603	Diode 1S2473VE	
D604	Diode 1S2473VE	
D605	Diode 1S2473VE	

11.10 POWER SUPPLY ASSEMBLY (RWR-026)

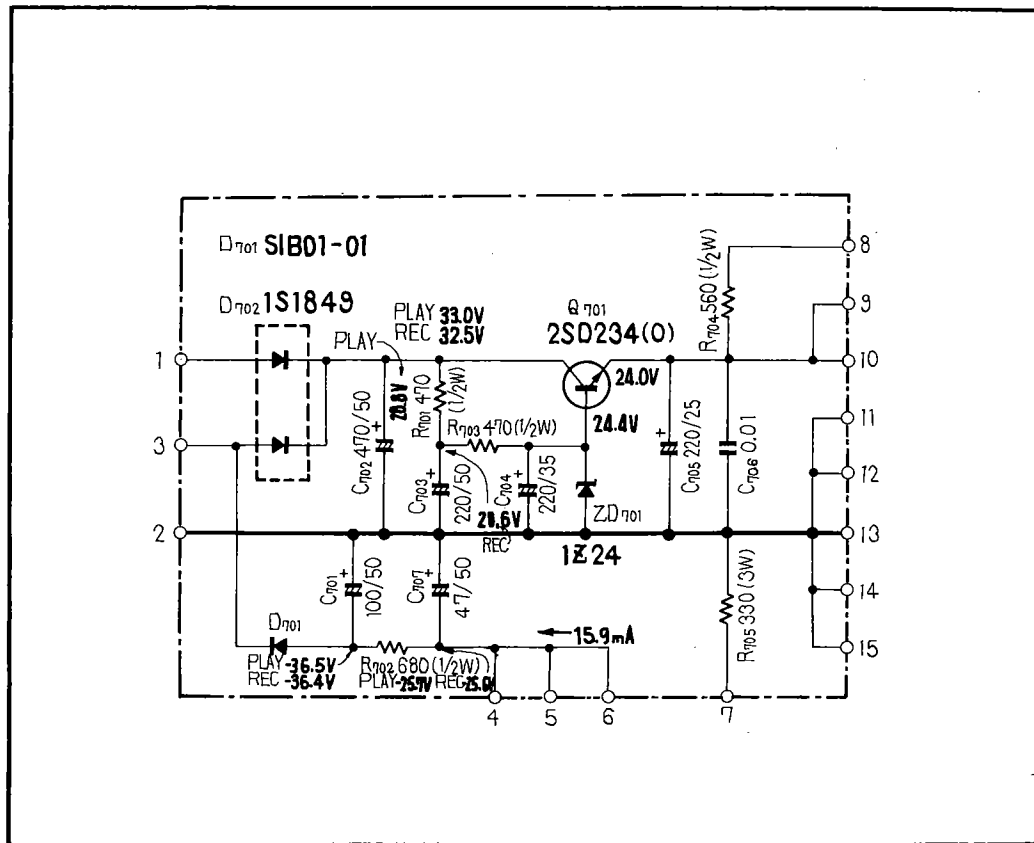

Parts List of Power Supply Assembly (RWR-026)

CAPACITORS

Symbol	Description	Part No.
C701	Electrolytic 100 50V	CEA 101P 50
C702	Electrolytic 470 50V	CEA 471P 50
C703	Electrolytic 220 50V	CEA 221P 50
C704	Electrolytic 220 35V	CEA 221P 35
C705	Electrolytic 220 25V	CEA 221P 25
C706	Ceramic 0.01 50V	CKDYF 103Z 50
C707	Electrolytic 47 50V	CEA 470P 50

SEMICONDUCTORS

Symbol	Description	Part No.
Q701	Transistor 2SD234-0	
D701	Diode SIB01-01	
D702	Diode 1S1849	
ZD701	Zener diode 1Z24	

RESISTORS

Symbol	Description	Part No.
R705	Metal oxide 330 3W	RS3P 331K
R701	Metal oxide 470 1/2W	RS1/2PSF 471J
R702	Metal oxide 680 1/2W	RS1/2PSF 681J
R703	Metal oxide 470 1/2W	RS1/2PSF 471J
R704	Metal oxide 560 1/2W	RS1/2PSF 561J

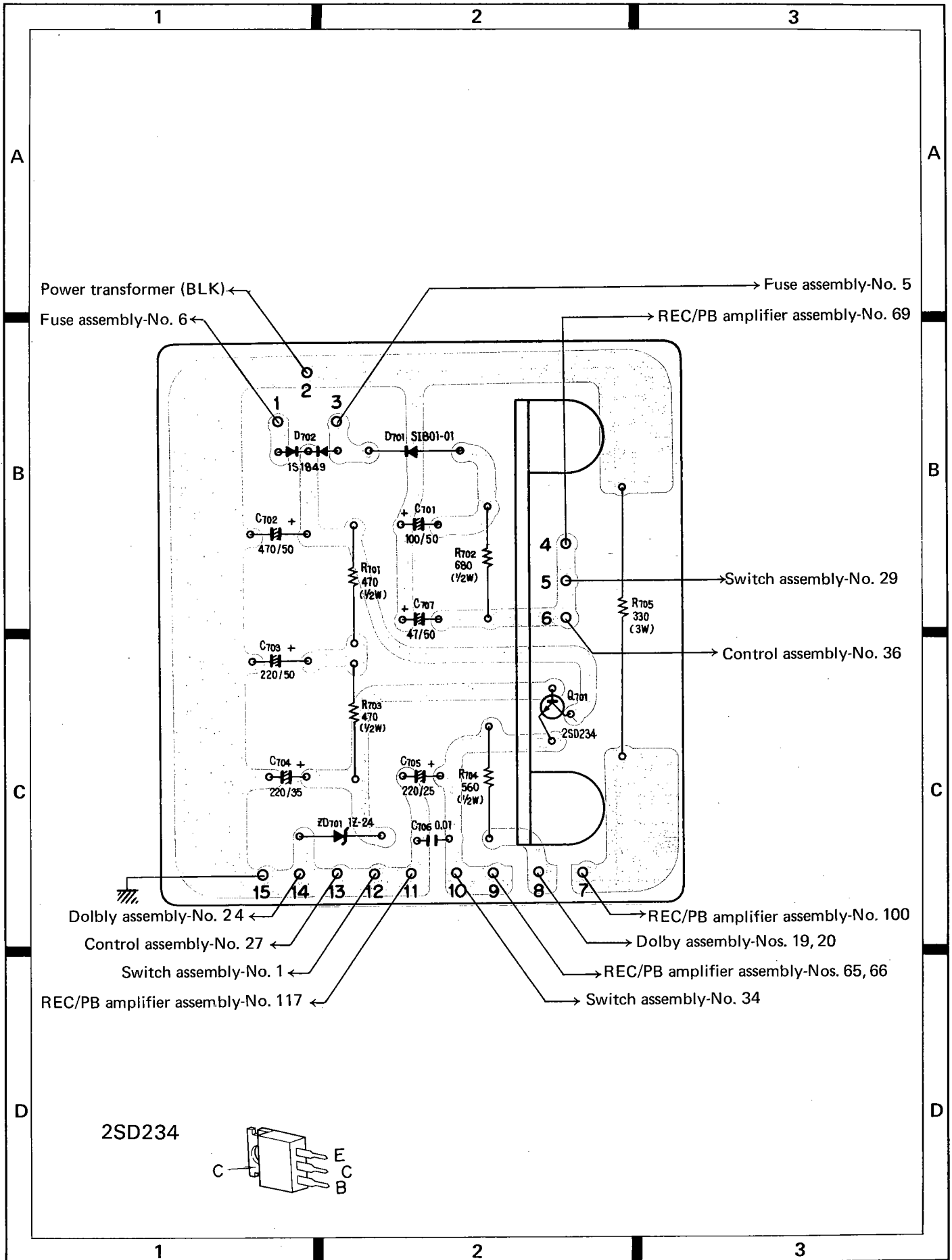

11.11 CONTROL ASSEMBLY VOLTAGE

POINT	STOP NO TAPE	STOP	PLAY	FF	REC	REC/PLAY	MEMORY PLAY	MEMORY R/P	AUTO STOP
①—E	24.5	24.5	22.0	22.5	23.0	21.0			
②—E	13.2	13.2	13.0	13.0	13.1	13.0			
③—E	12.6	12.6	12.4	12.4	12.5	12.4			
④—E		14.6							
⑥—E			4.4						
⑥—T			3.2						3.5 → 0
⑧—E			0						0.6
⑨—E		-0.7	12.4		12.5	12.4			
⑩—E		14.0	11.8						
⑪—⑫				± 11.5					
⑬—E			-0.4				0.7		
⑭—E			0.09				6.3		
⑮—E			0.7				0.05		
⑯—E			0.05				0.7		
⑰—E			6.3				0.09		
⑱—E			0.7				-0.4		
⑲—E		-26.0							
⑳—E	10.6					9.7			
㉑—E	10.2					8.9			
㉒—㉓				7.4					
㉔—㉕			7.8			7.5			
㉖—㉗					8.0	8.3			
㉘—E				1.0					
㉙—E			0.5			0.5			
㉚—E					0.2	0.2			
㉛—E	10.6					10.4			
㉜—㉝			-1.0	+ 9.2					
㉞—E	12.6		1.8	2.6					
㉟—E			0.2	10.9					
㊱—E						11.8		11.2	
㊲—E						6.2		1.0	
㊳—E						1.5		0.4	
㊴—E						0.7		0.03	

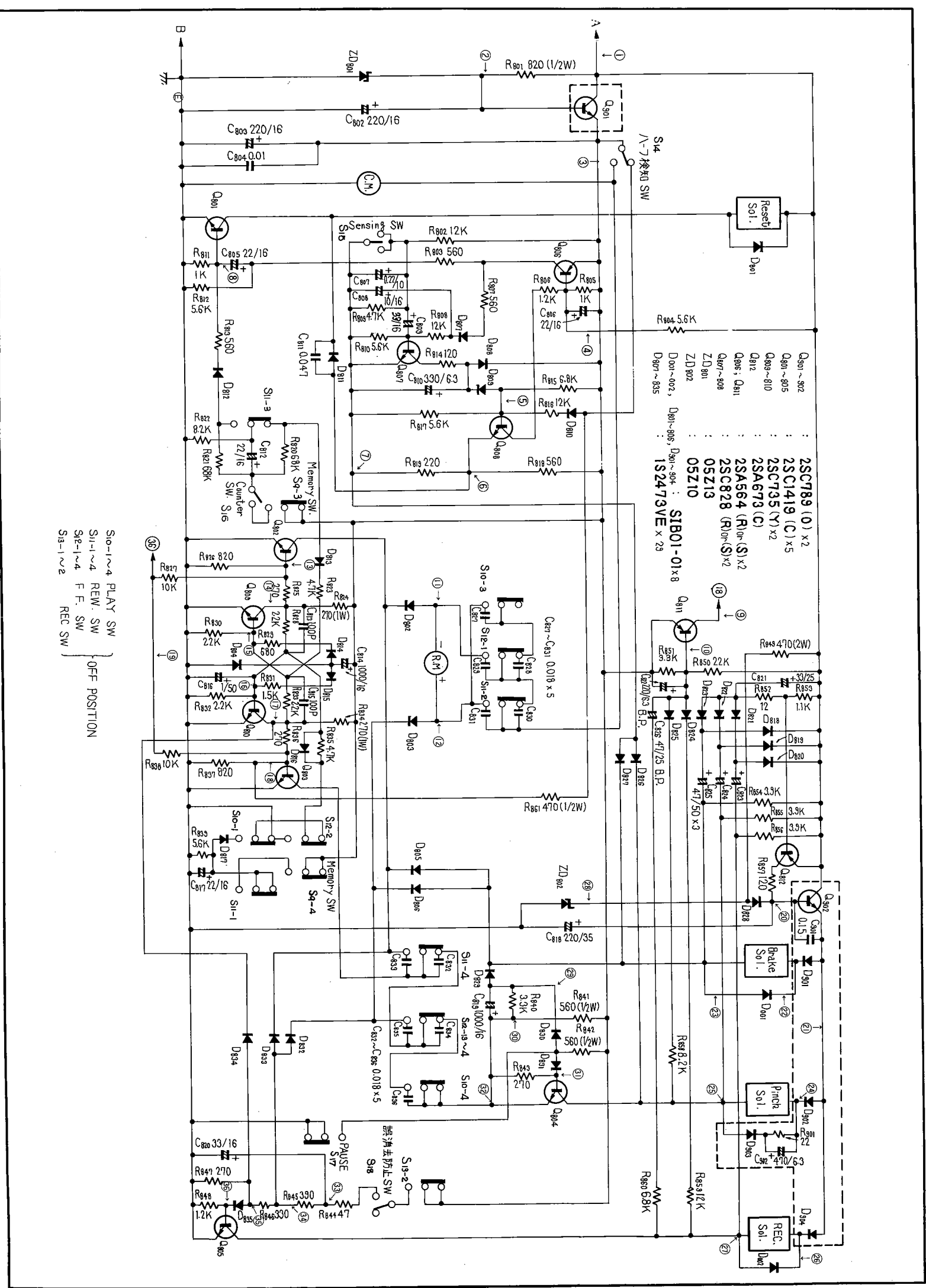

TIMING CHART

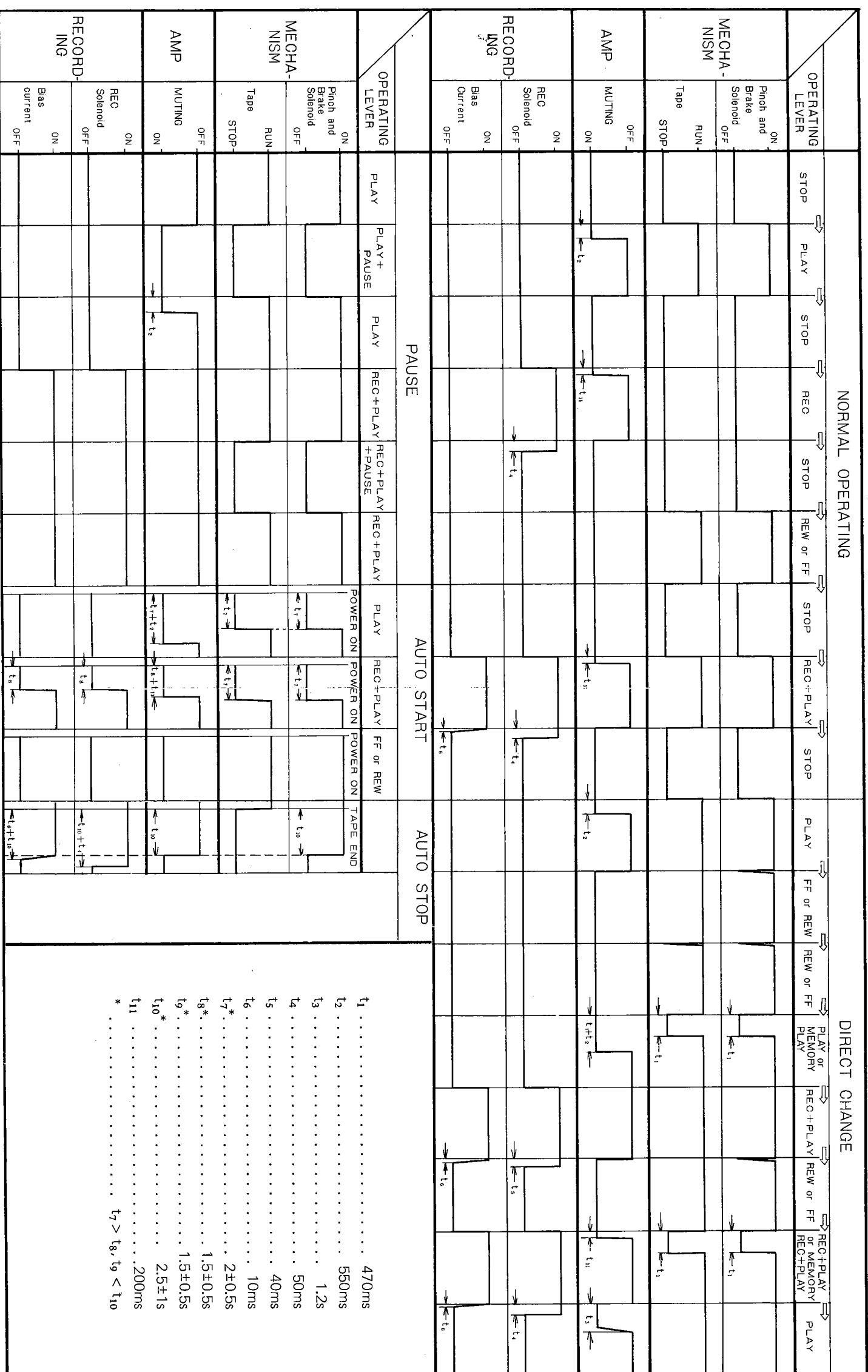

13. EXPLODED VIEW

NOTE:
Part indicated in green type cannot be supplied.

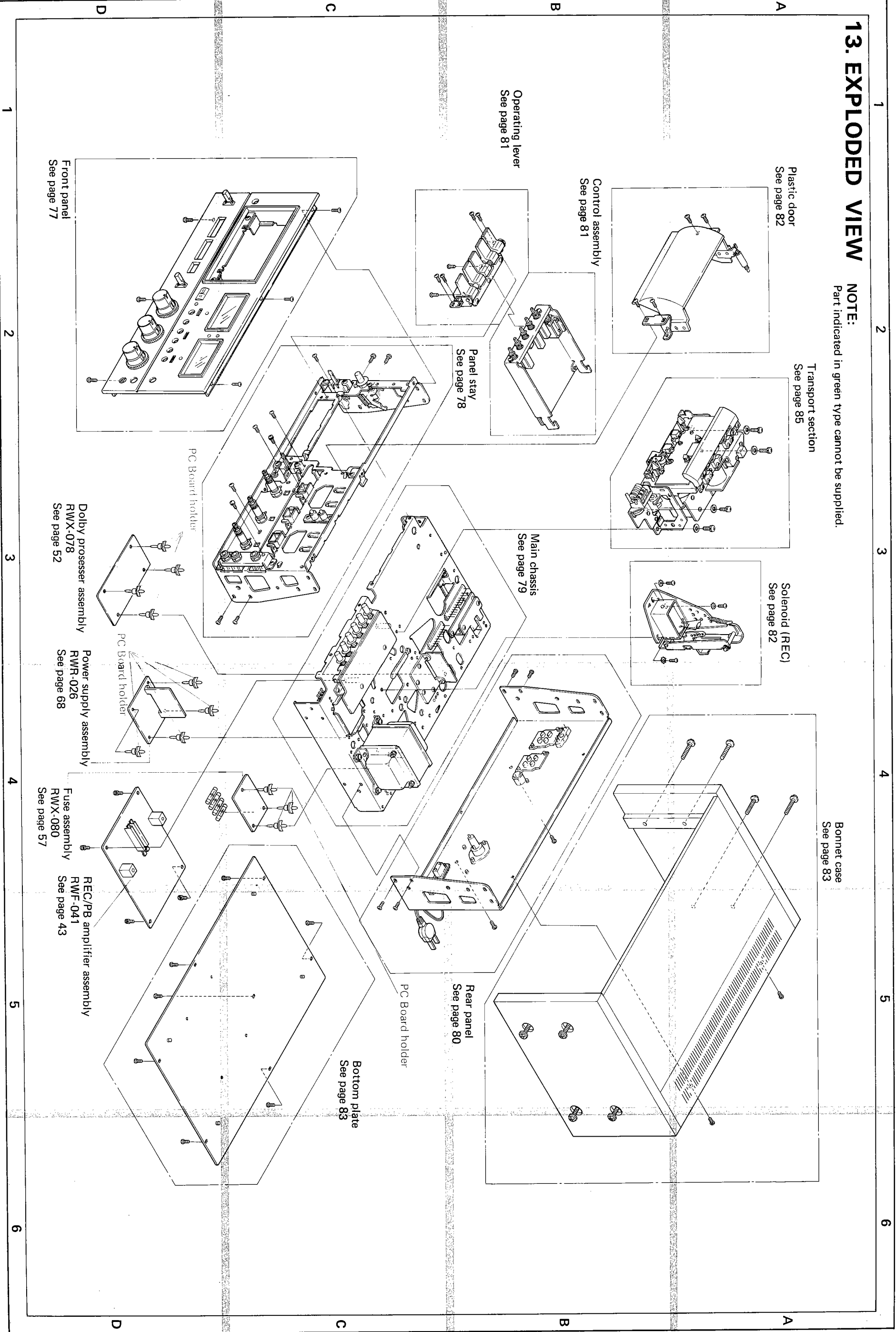

1.1 FRONT PANEL

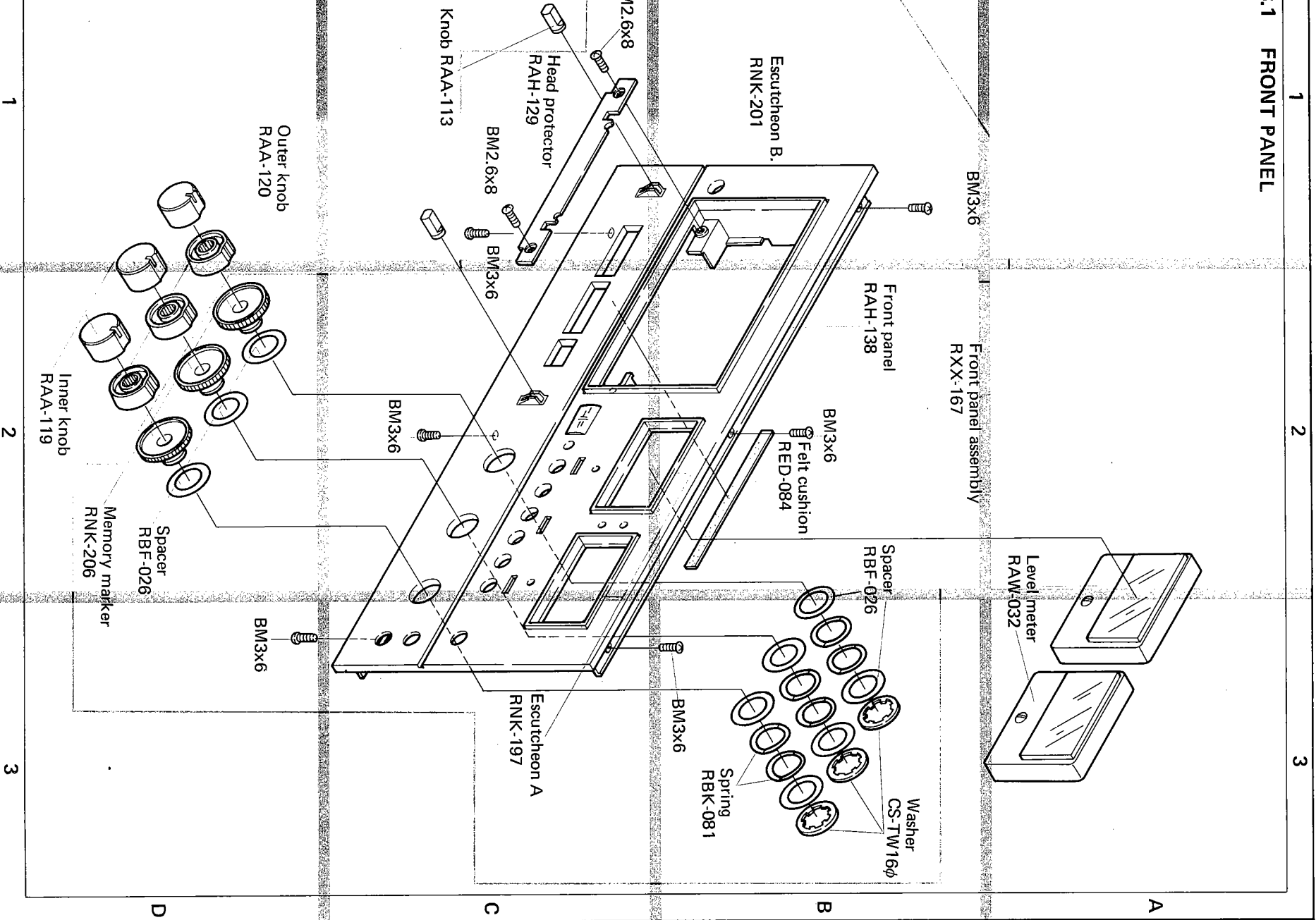

13.2 PANEL STAY

NOTE:
Parts indicated in green type cannot be supplied.

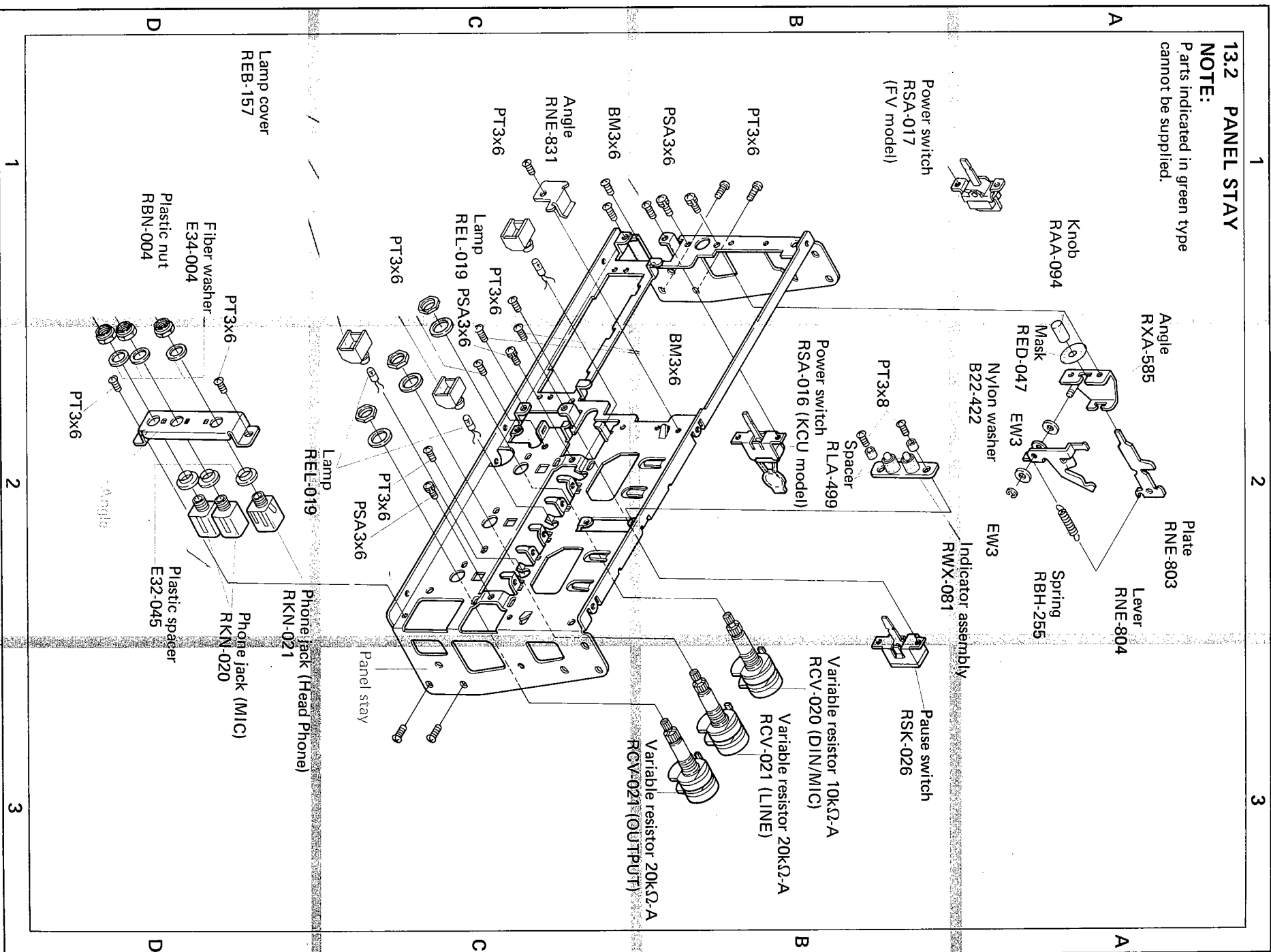

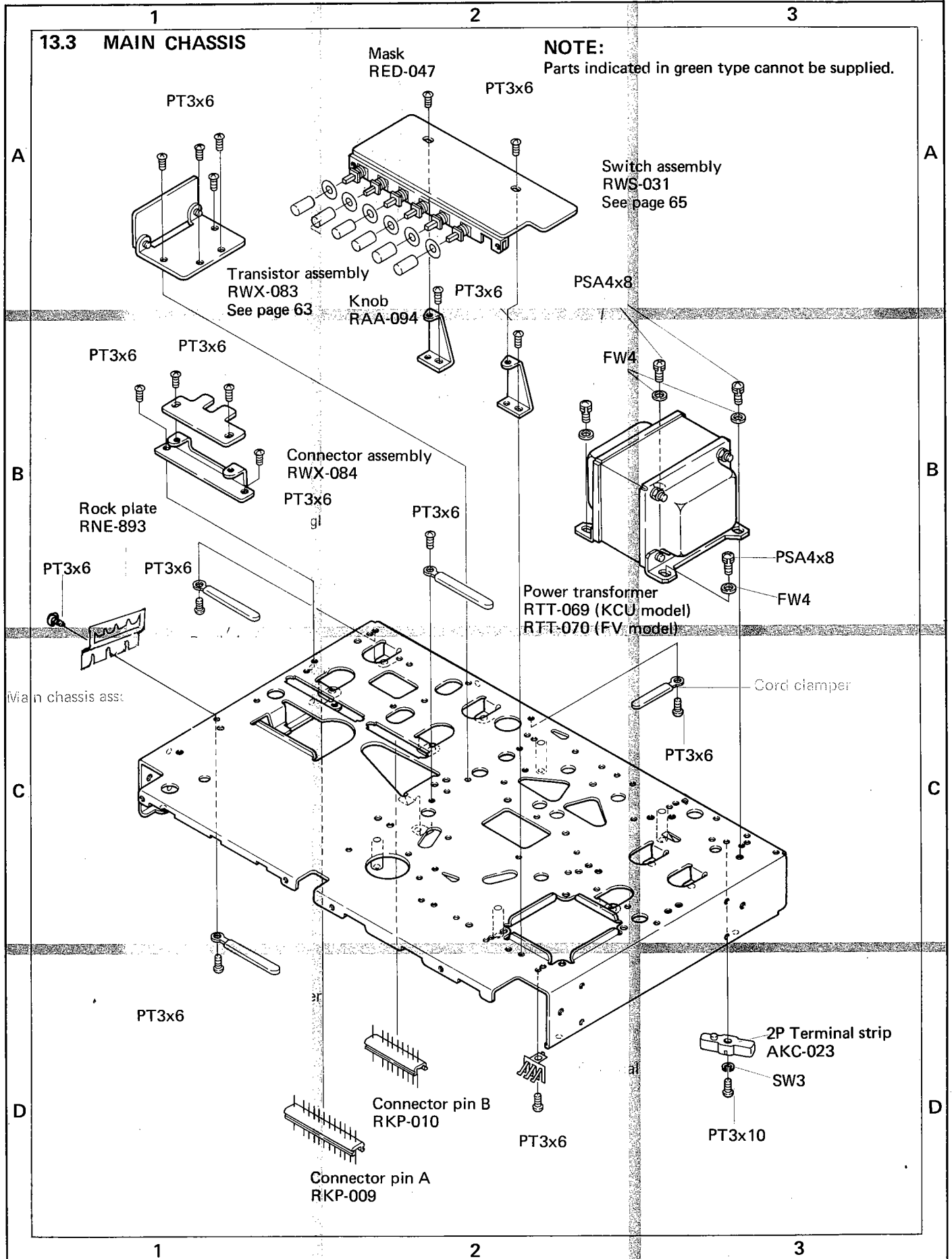

13.4 REAR PANEL

NOTE:

Parts indicated in green type cannot be supplied.

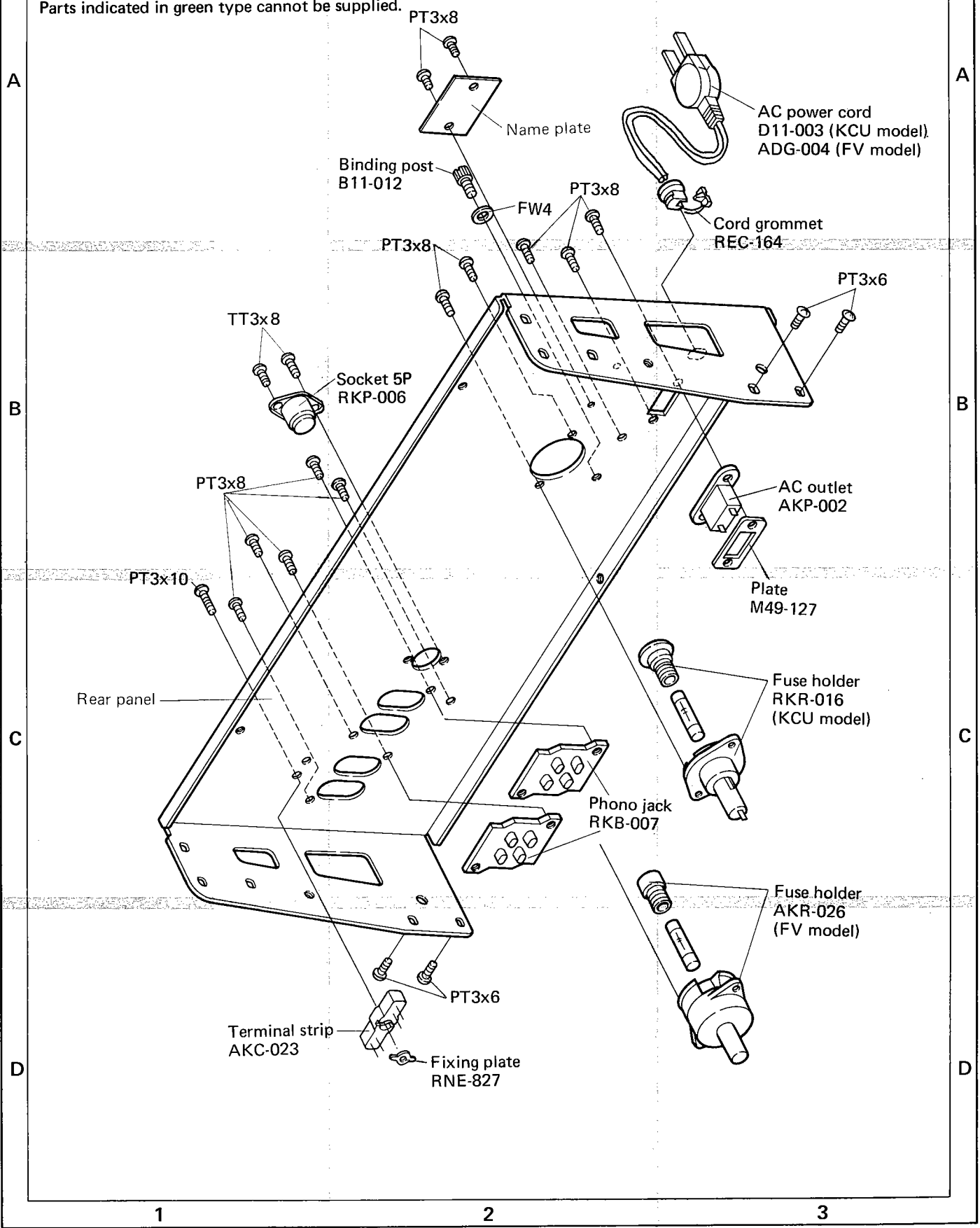

13.5 OPERATING LEVERS

NOTE:

Parts indicated in green type cannot be supplied.

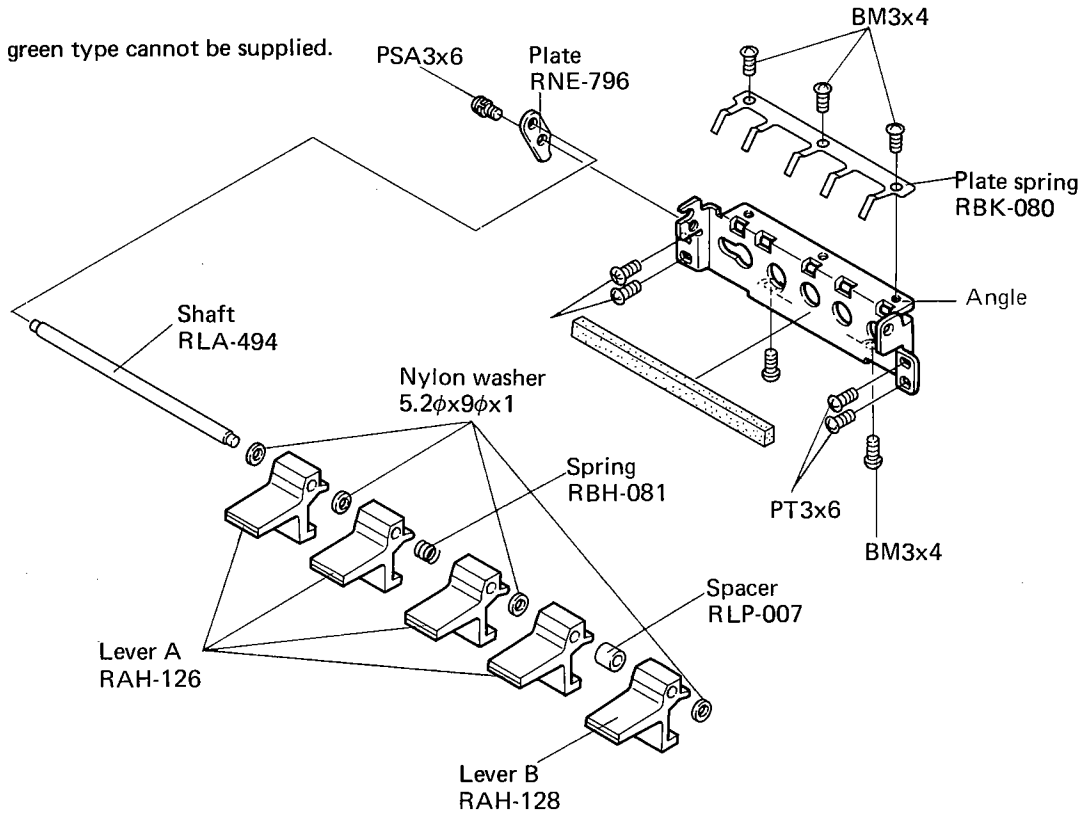

13.6 CONTROL ASSEMBLY (RWG-048)

NOTE:

Parts indicated in green type cannot be supplied.

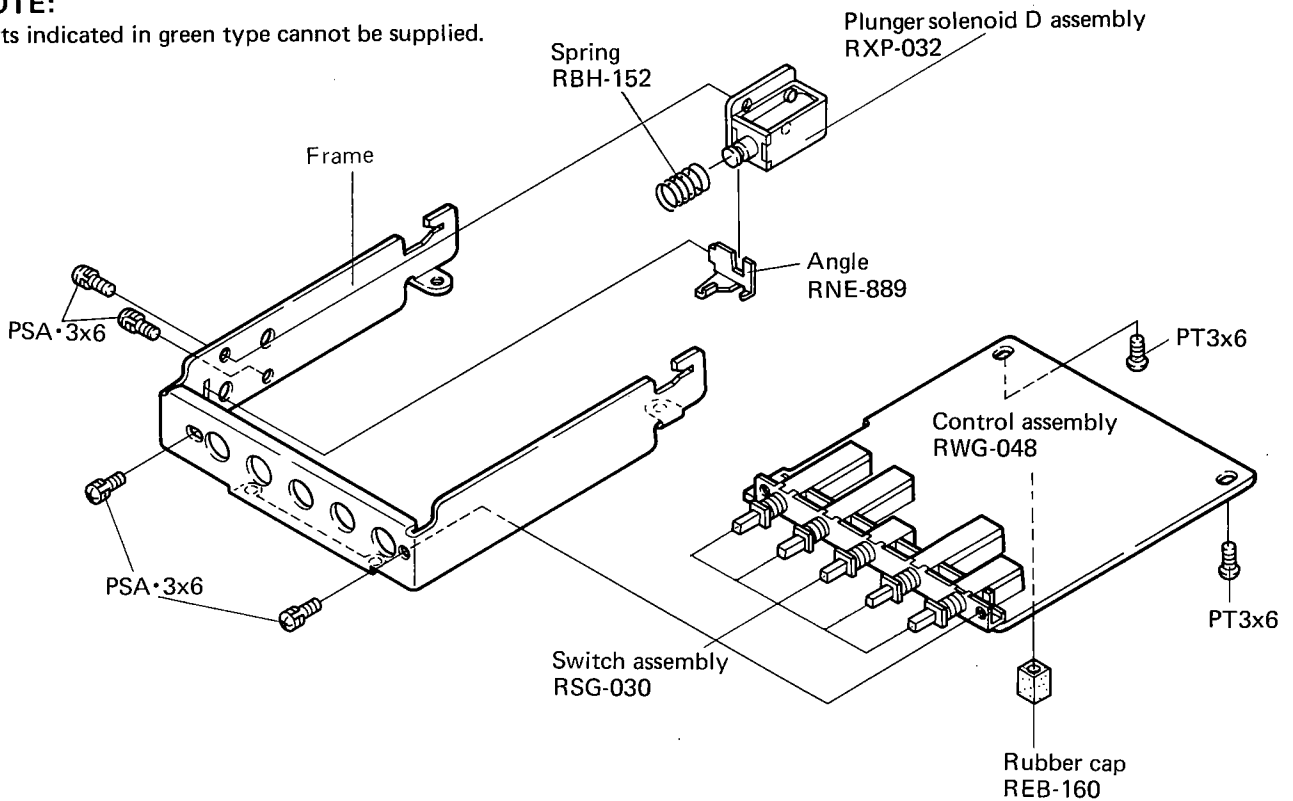

13.7 SOLENOID (REC)

NOTE:

Parts indicated in green type cannot be supplied.

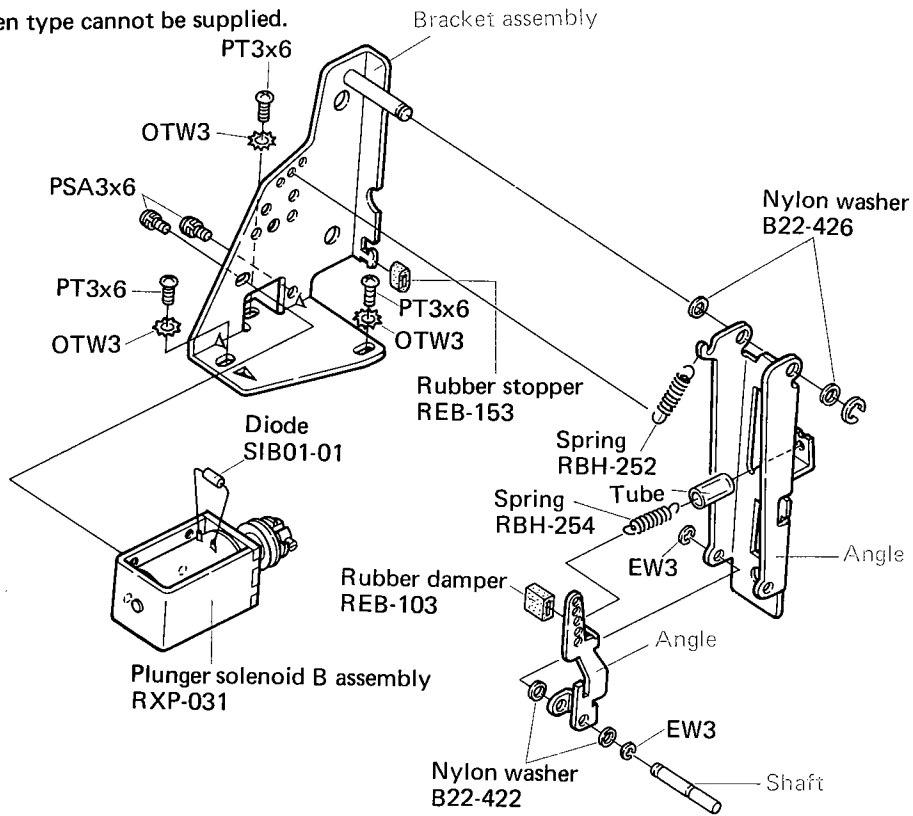

13.8 PLASTIC DOOR

NOTE:

Parts indicated in green type cannot be supplied.

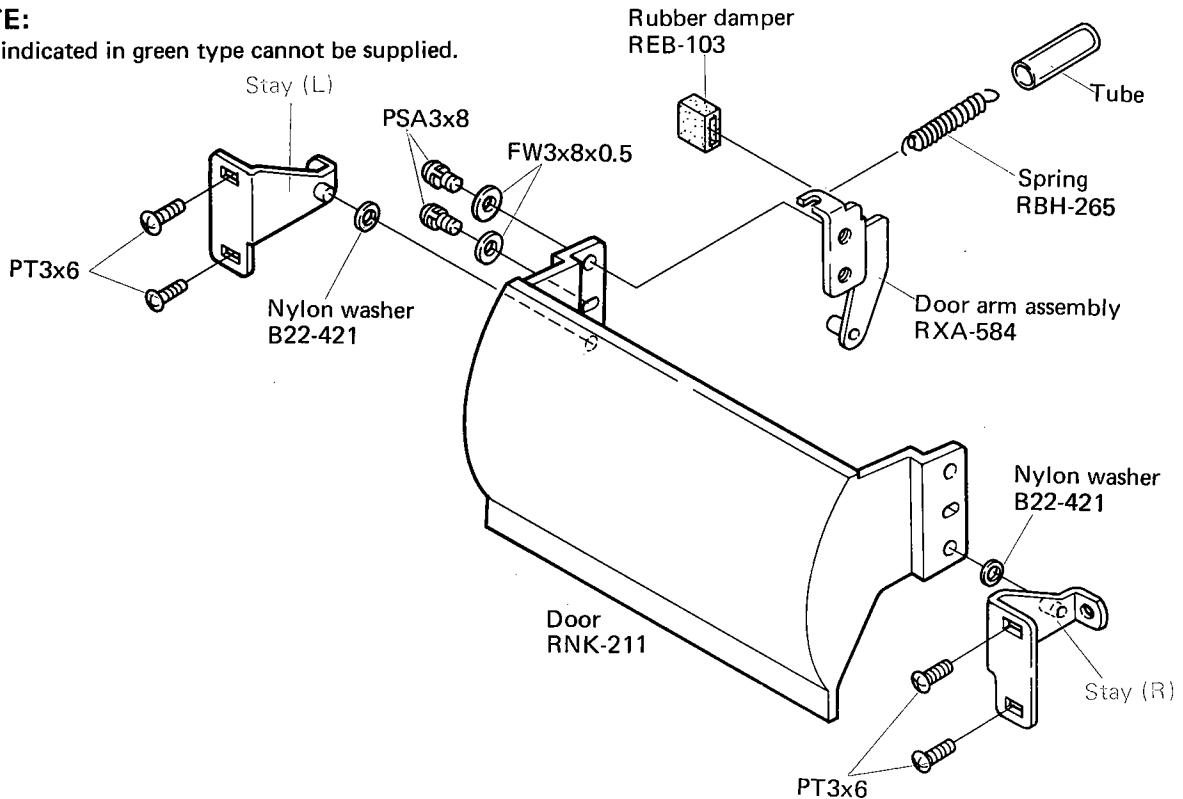

13.9 BONNET CASE

NOTE:

Parts indicated in green type cannot be supplied.

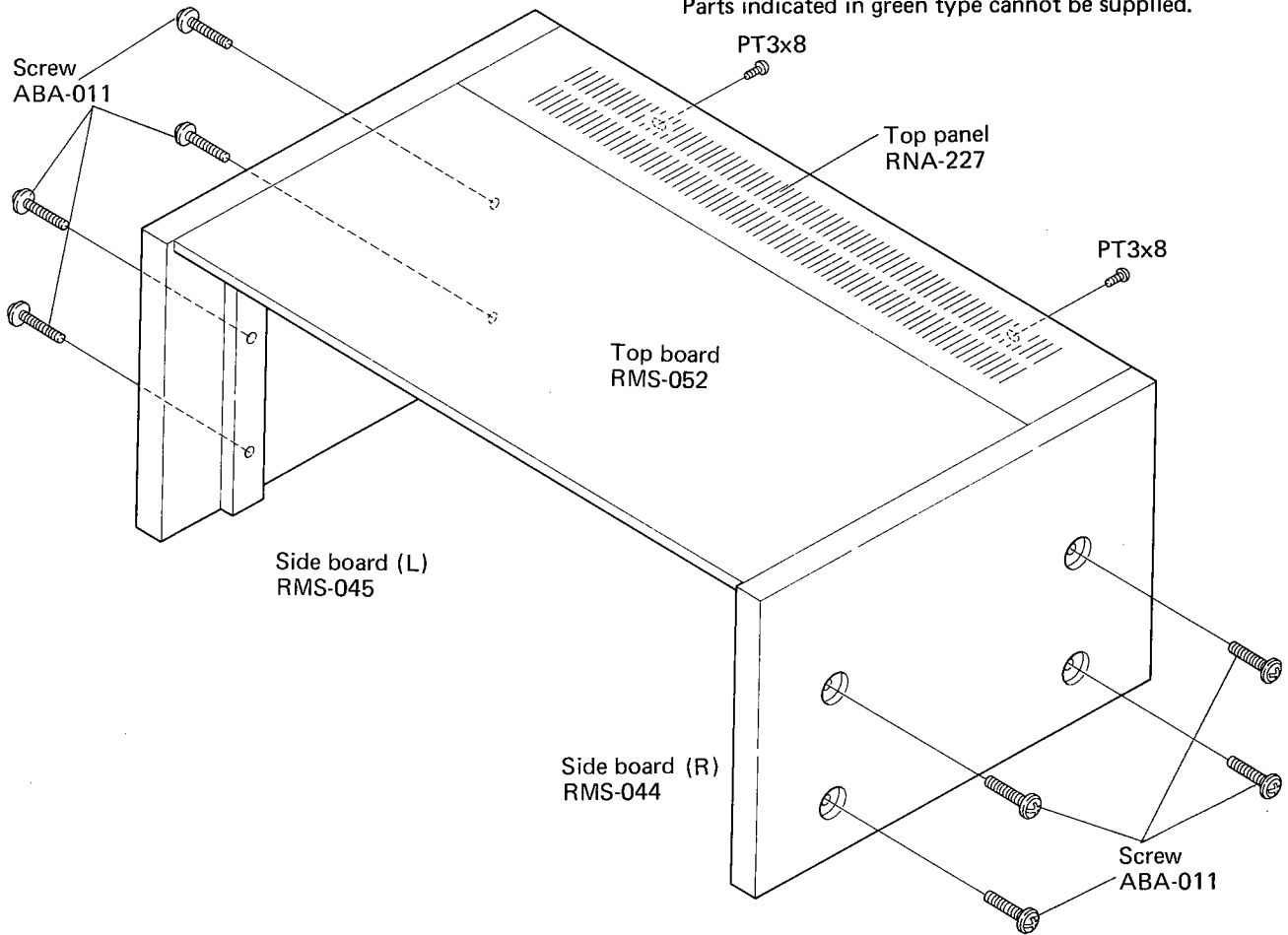

13.10 BOTTOM PLATE

NOTE:

Parts indicated in green type cannot be supplied.

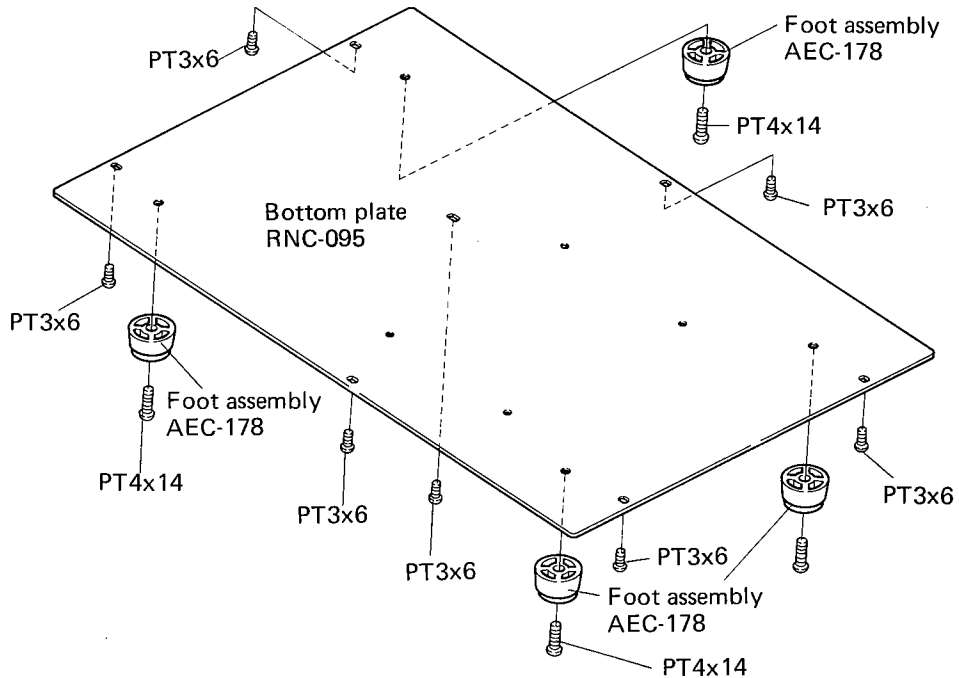

13.11 NOMENCLATURE OF SCREWS, WASHERS AND NUTS

The following symbols stand for screws, washers and nuts as shown in exploded view.

Symbol	Description	Shape
RT	Brazier head tapping screw	
PT	Pan head tapping screw	
BT	Binding head tapping screw	
CT	Countersunk head tapping screw	
TT	Truss head tapping screw	
OCT	Oval countersunk head tapping screw	
PM	Pan head machine screw	
CM	Countersunk head machine screw	
OCM	Oval countersunk head machine screw	
TM	Truss head machine screw	
BM	Binding head machine screw	
PSA	Pan head screw with spring lock washer	
PSB	Pan head screw with spring lock washer and flat washer	
PSF	Pan head screw with flat washer	

Symbol	Description	Shape
EW	E type washer	
FW	Flat washer	
SW	Spring lock washer	
N	Nut	
WN	Washer faced nut	
ITW	Internal toothed lock washer	
OTW	Outernal toothed lock washer	
SC	Slotted set screw (Cone point)	
SF	Slotted set screw (Flat point)	
HS	Hexagon socket headless set screw	
OCW	Oval countersunk head wood screw	
CW	Countersunk head wood screw	
RW	Round head wood screw	

EXAMPLE

PM · 3x8
 length in mm (l)
 diameter in mm (d)
 Symbol

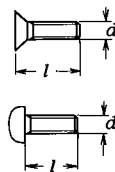

FW · 9φ x 1^t
 thickness in mm (t)
 diameter in mm (d)
 Symbol

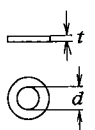

REEL ASSEMBLY

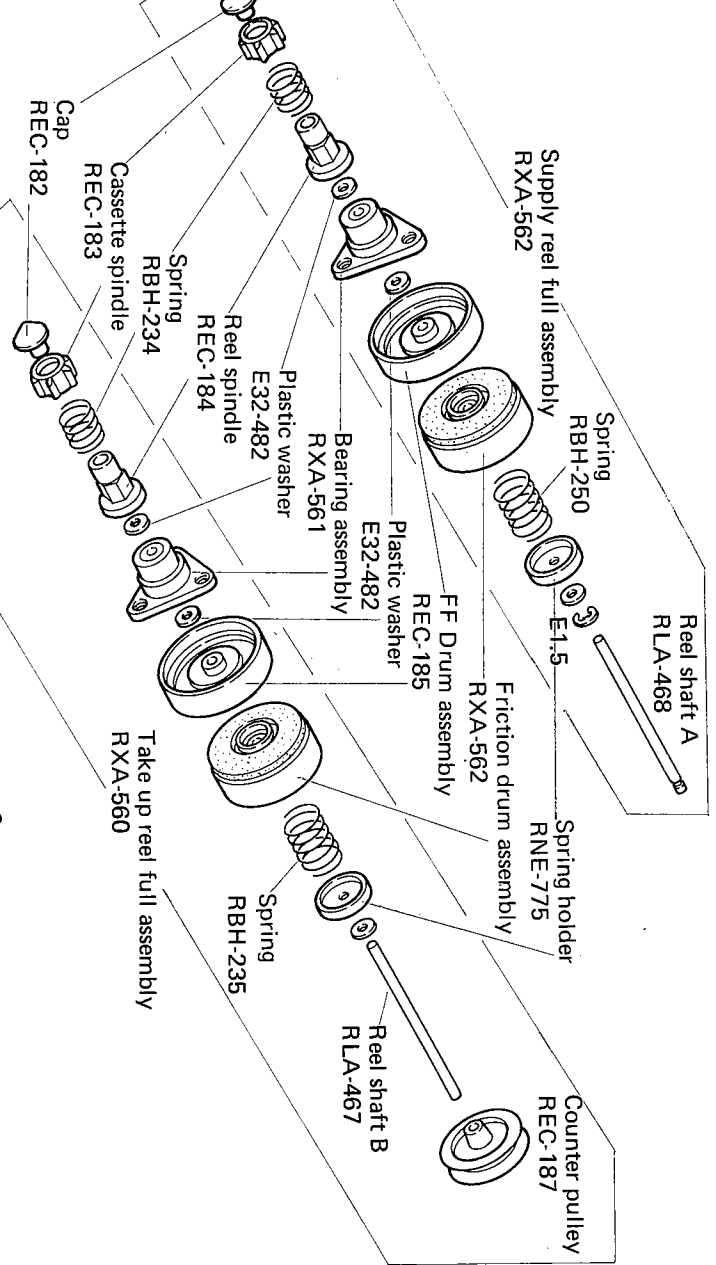

FF MOTOR

Parts indicated in green type cannot be supplied.

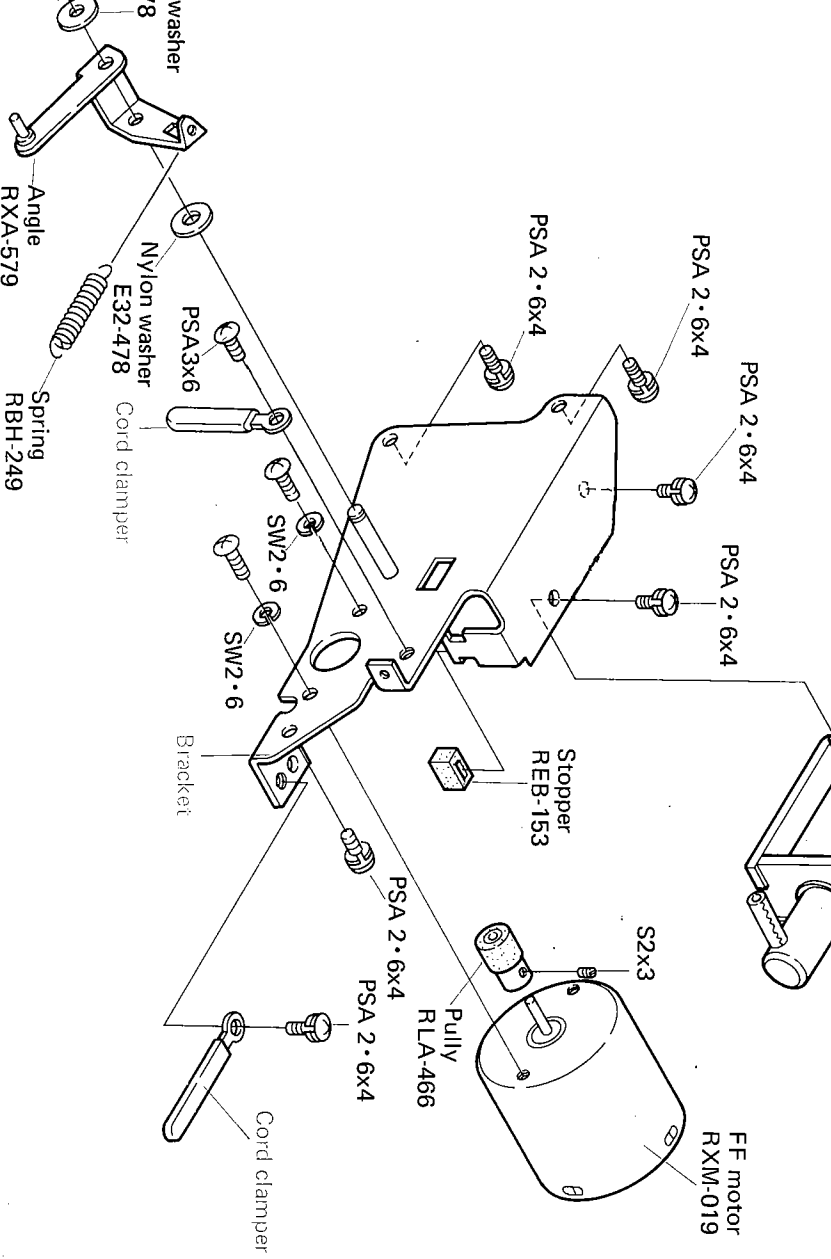

14.3 IDLER A

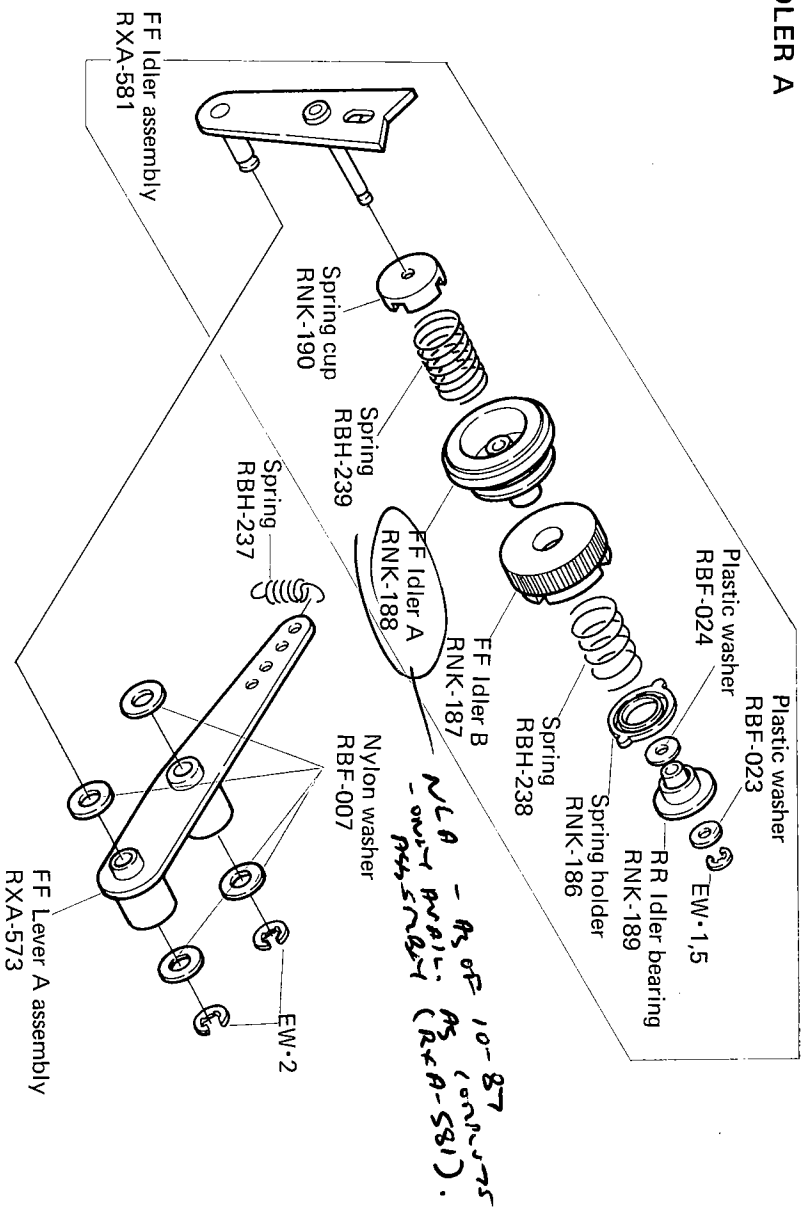

14.4 TAPE COUNTER

Parts indicated in green type cannot be supplied.

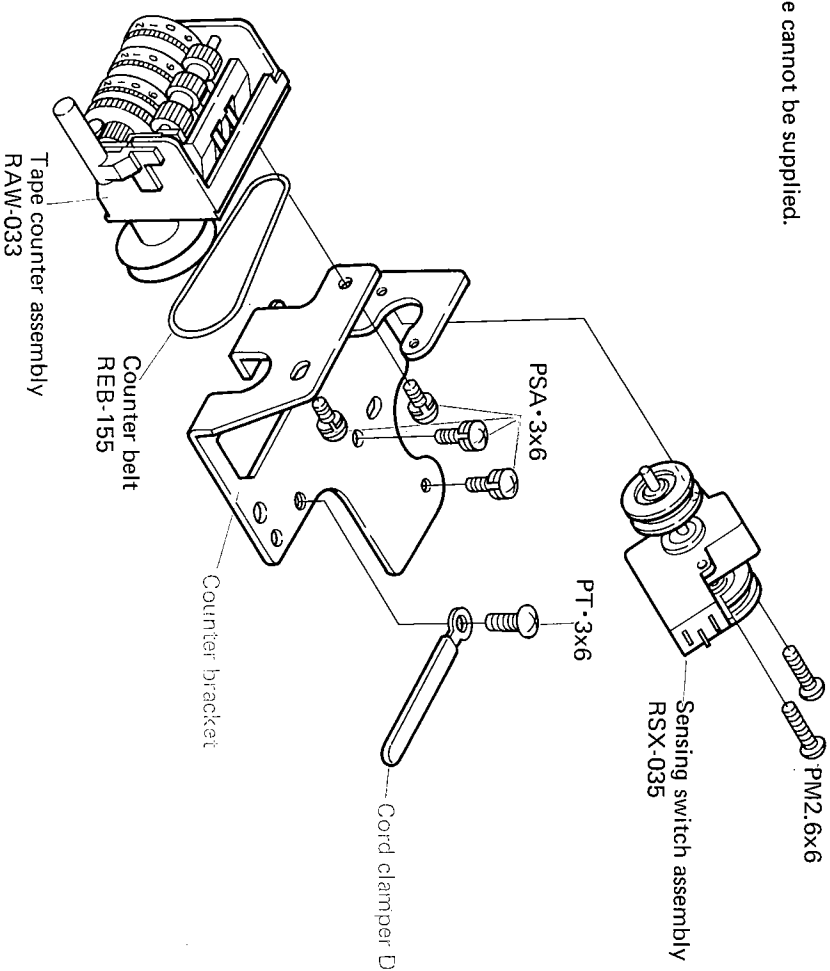

14.5 IDLER B

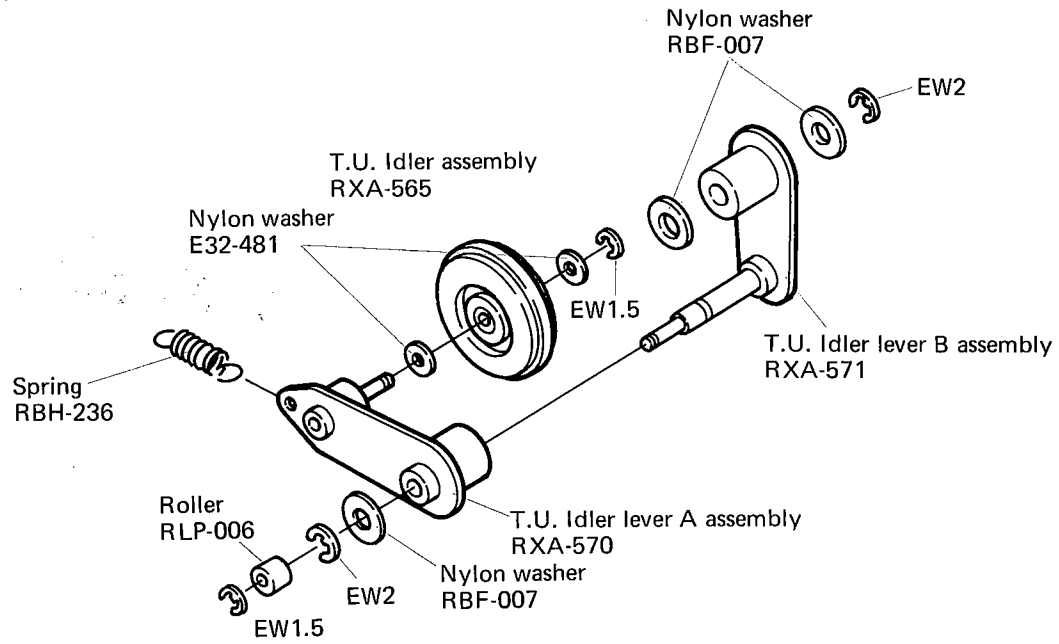

14.6 MICROSWITCH

NOTE:

Parts indicated in green type cannot be supplied.

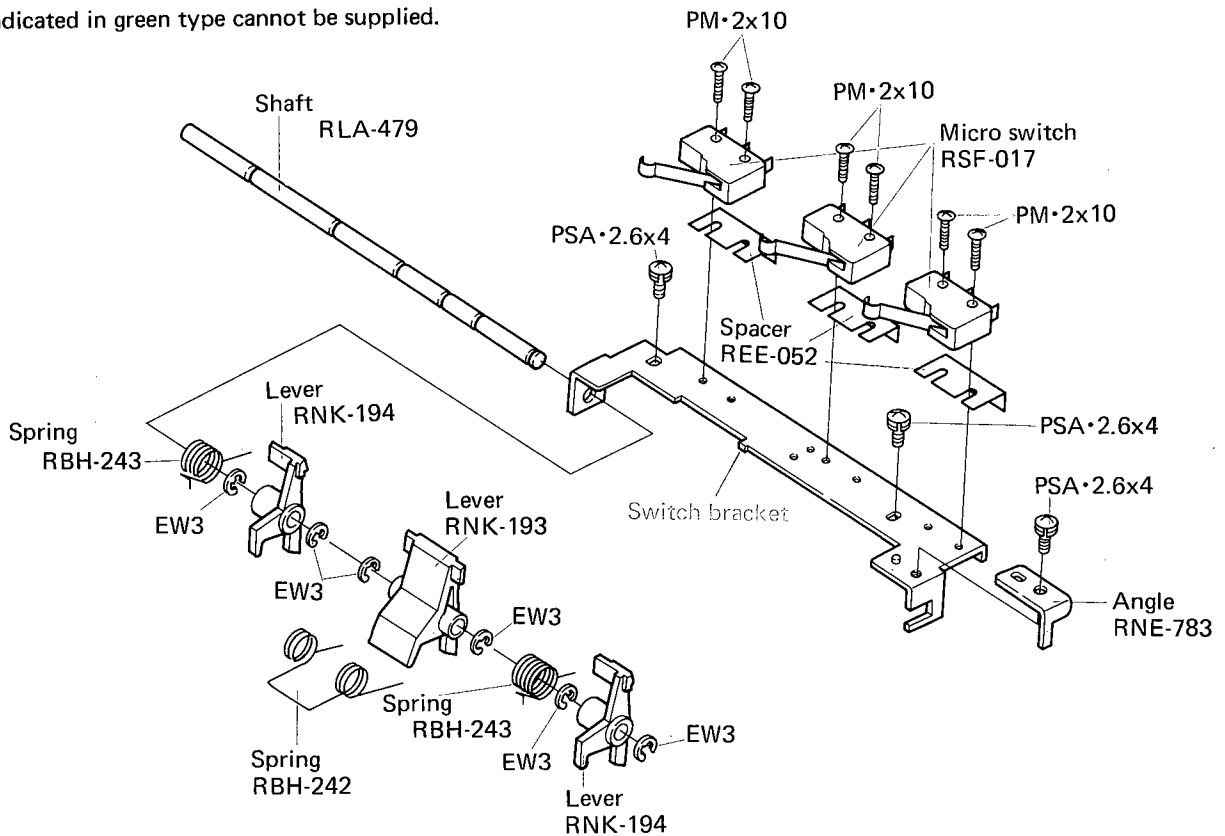

14.7 PANEL A

NOTE:

Parts indicated in green type cannot be supplied.

A

B

C

D

1

2

3

A

B

C

D

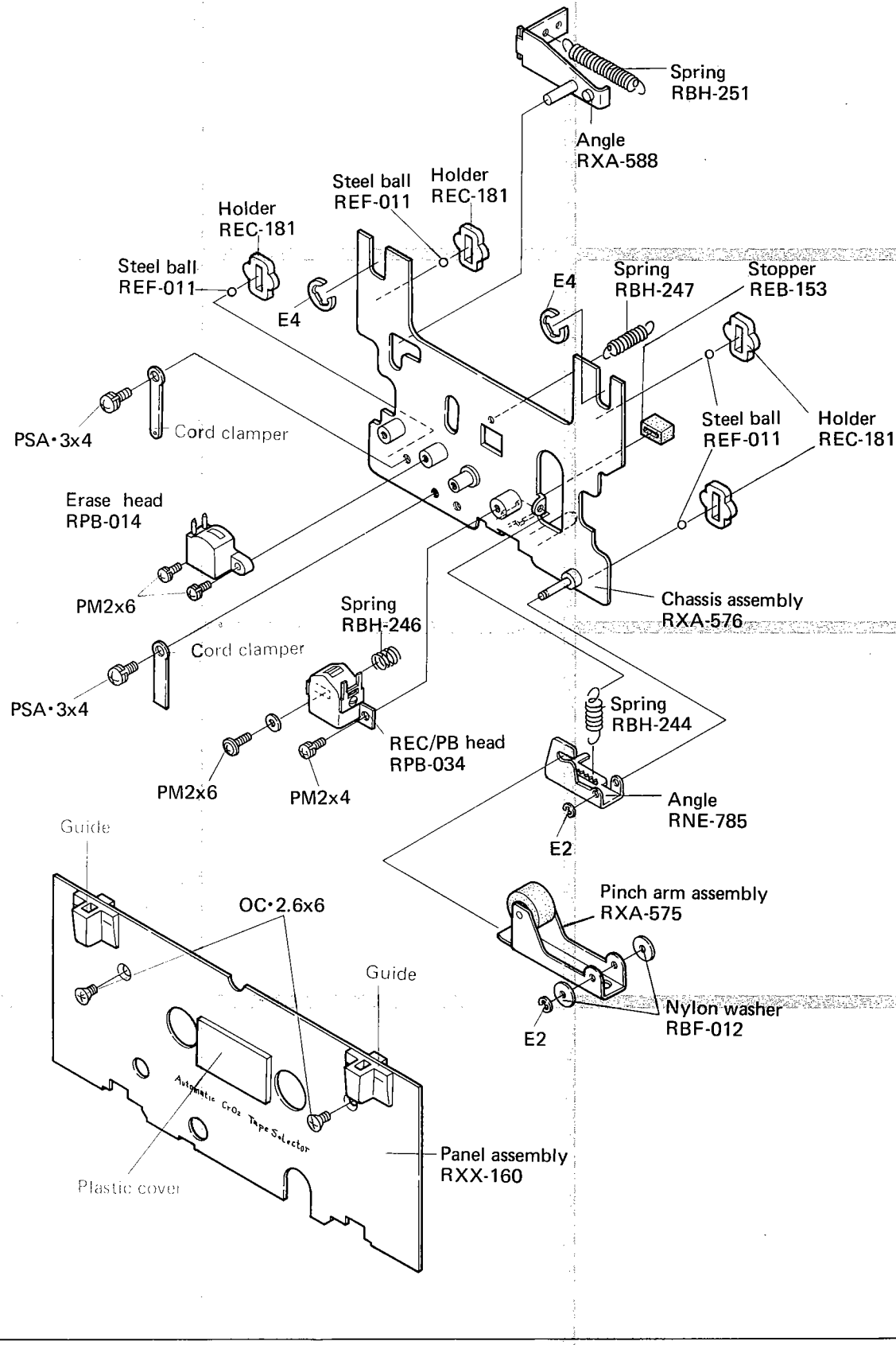

1

2

3

15. PACKING

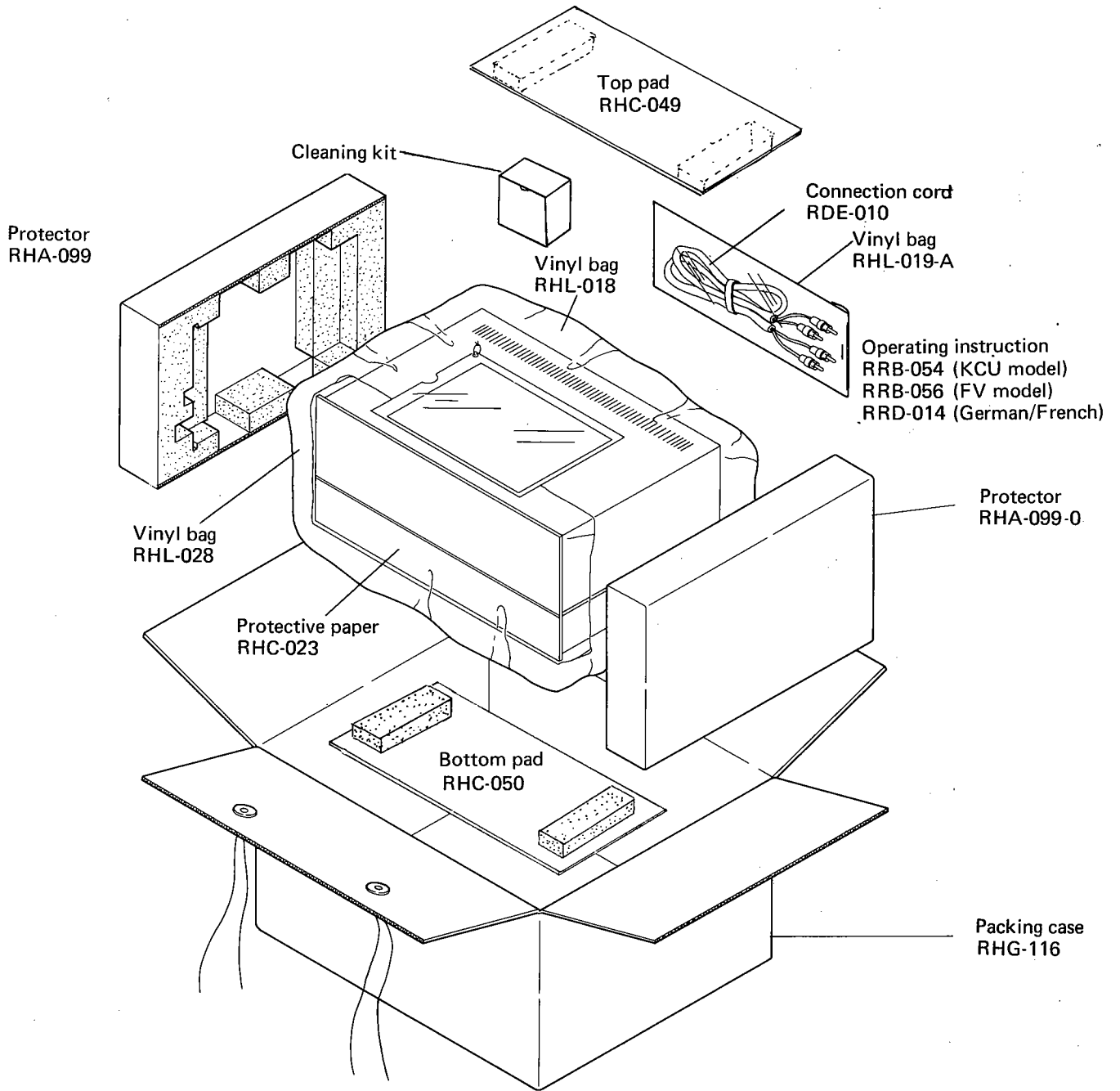

16. PARTS LIST OF EXPLODED VIEW

Parts No.	Parts Name
ABA-011	Screw
ADG-004	AC Power Cord (FV Model)
AEC-178	Foot Assembly
AKC-023	2P Terminal Strip
AKP-002	AC Outlet
AKR-026	Fuse Holder (FV MODEL)
AKR-027	Fuse Holder
RAA-093	Knob
RAA-094	Knob (DOOR OPEN)
RAA-113	Knob (POWER, PAUSE)
RAA-119	Inner Knob
RAA-120	Outer Knob
RAH-126	Lever (PLAY, REW, FF, STOP)
RAH-128	Lever (REC)
RAH-129	Head Protector
RAW-032	Level Meter
RAW-033	Tape Counter Assembly
RBF-007	Nylon Washer
RBF-012	Nylon Washer
RBF-023	Plastic Washer
RBF-024	Plastic Washer
RBF-026	Spacer
RBH-081	Spring
RBH-152	Spring
RBH-232	Spring
RBH-234	Spring
RBH-235	Spring
RBH-236	Spring
RBH-237	Spring
RBH-238	Spring
RBH-239	Spring
RBH-240	Spring
RBH-241	Spring
RBH-242	Spring
RBH-243	Spring
RBH-244	Spring
RBH-245	Spring
RBH-246	Spring
RBH-247	Spring
RBH-248	Spring
RBH-249	Spring
RBH-250	Spring
RBH-251	Spring
RBH-252	Spring
RBH-254	Spring
RBH-255	Spring
RBK-080	Plate Spring
RBK-081	Spring
RBN-004	Plastic Nut

Parts No.	Parts Name
RCV-020	Variable Resistor (MIC DIN)
RCV-021	Variable Resistor (LINE OUTPUT)
REB-103	Rubber Damper
REB-150	Capstan Belt
REB-151	Rubber
REB-153	Rubber Stopper
REB-155	Counter Belt
REB-156	Sensing Belt
REB-157	Lamp Cover
REB-160	Rubber Cap
REC-164	Cord Grommet
REC-181	Holder
REC-182	Cap
REC-183	Cassette Spring
REC-184	Reel Spindle
REC-185	FF Drum Assembly
REC-187	Counter Pulley
RED-047	Mask
RED-084	Felt Cushion
REE-052	Spacer
REF-011	Steel Ball
REL-019	Lamp
RHA-099	Protector
RHC-049	Top Pad
RHC-050	Bottom Pad
RHG-116	Packing Case
RHL-018	Vinyl Bag
RHL-028	Vinyl Bag
RKB-007	Phono Jack (4 Jack)
RKN-020	Mic Jack Assembly
RKN-021	Phone Jack Assembly
RKP-006	5P Jack (DIN)
RKP-007	Connector Socket A Assembly
RKP-008	Connector Socket B Assembly
RKP-009	Connector Pin A
RKP-010	Connector Pin B
RKR-016	Fuse Holder (KCU Model)
RLA-465	Pulley
RLA-466	Pulley
RLA-467	Reel Shaft B
RLA-468	Reel Shaft A
RLA-479	Shaft
RLA-494	Shaft
RLA-499	Spacer
RLP-007	Spacer
RMS-044	Side Board (R)
RMS-045	Side Board (L)
RMS-052	Top Board

Parts No.	Parts Name
RNE-763	Angle
RNE-773	Angle
RNE-775	Spring Holder
RNE-783	Angle
RNE-786	Lever
RNE-785	Angle
RNE-796	Plate
RNE-803	Plate
RNE-804	Lever
RNE-827	Fixing Plate
RNE-831	Angle
RNE-857	Angle
RNK-198	Spring Holder
RNK-198	FF Idler B
RNK-199	FF Idler A
RNK-203	RR Idler Bearing
RNK-211	Spring Cup
RNK-205	Lever
RNK-206	ON Indicator
RFB-034	CrO ₂ Indicator
RFB-014	Counter Cover
RFB-054	Door
RFD-014	Cover
RSA-016	Memory Marker
RSA-017	REC/PB Head
RSE-017	Erase Head
RSG-030	Operating Instruction (KCU MODEL)
RSK-026	Operating Instruction (FV MODEL)
RSX-035	Lever Switch (KCU MODEL)
RTT-069	Lever Switch (FV MODEL)
RTT-070	Microswitch
RWF-041	Switch Assembly
RWG-048	Lever Switch (PAUSE)
RWR-026	Sensing Switch Assembly
RWX-078	Power Transformer (KCU MODEL)
RWX-080	Power Transformer (FV MODEL)
RWX-081	REC/PB Amplifier Assembly
RWX-083	Control Assembly
RWX-084	Power Supply Assembly
RXA-558	Switch Assembly
RXA-560	Dolby Assembly
RXA-561	Fuse Assembly
RXA-562	Indicator Assembly
RXA-563	Transistor Assembly
RXA-564	Connector Assembly
RXA-565	Bearing Assembly
RXA-566	Take Up Reel Full Assembly
RXA-567	Bearing Assembly
RXA-568	Friction Drum Assembly
RXA-569	Supply Reel Full Assembly

Parts No.	Parts Name
RXA-565	T.U. Idler Assembly
RXA-570	T.U. Idler Assembly
RXA-571	T.U. Idler Lever B Assembly
RXA-573	FF Lever A Assembly
RXA-574	Protection Assembly
RXA-575	Pinch Arm Assembly
RXA-576	Chassis Assembly
RXA-579	Angle
RXA-581	FF Idler Assembly
RXA-584	Door Arm Assembly
RXA-585	Angle
RXA-588	Shaft holder
RXM-018	Main Motor
RXM-019	FF Motor
RXP-029	Plunger Solenoid
RXP-030	Plunger Solenoid
RXP-031	Plunger Solenoid Assembly
RXP-032	Plunger Solenoid Assembly
RXX-160	Panel Assembly
RXX-167	Front Panel Assembly
B11-012	Binding Post
B22-421	Nylon Washer
B22-422	Nylon Washer
B22-426	Nylon Washer
D11-003	AC Power Cord (KCU MODEL)
E32-045	Plastic Spacer
E32-478	Nylon Washer
E32-481	Nylon Washer
E32-482	Plastic Washer
E34-004	Fiber Washer
K82-012	AC Socket
M49-127	Plate
SIB01-01	Diode
RBH-265	Spring
RNE-889	Angle
REL-027	Lamp Assembly
RNK-197	Escutcheon A
RNK-201	Escutcheon B
RXX-167	Front panel assembly



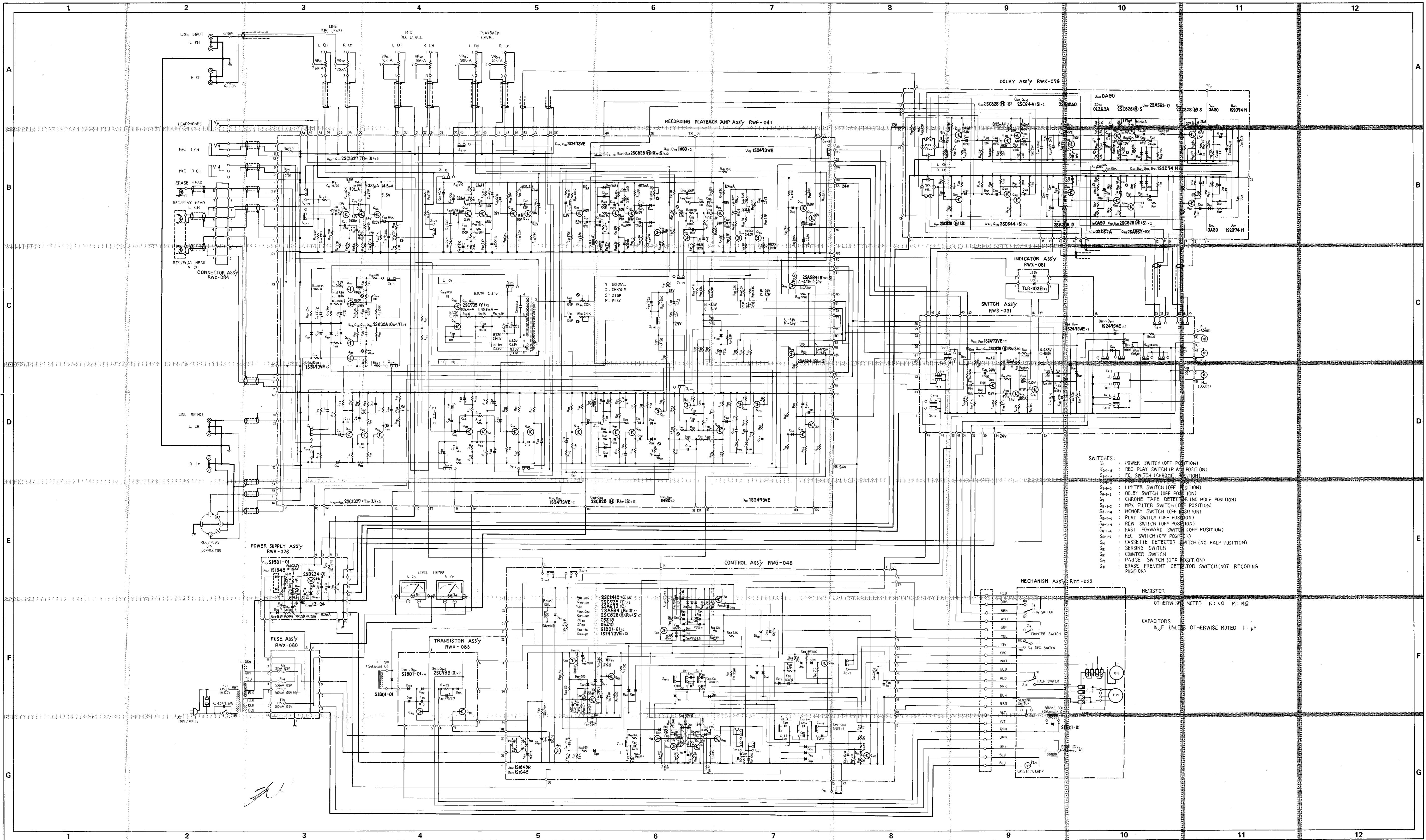

- SWITCHES :
- S₁ : POWER SWITCH (OFF POSITION)
 - S₁₋₁ : REC-PLAY SWITCH (PLAY POSITION)
 - S₁₋₂ : EQ SWITCH (CHROME POSITION)
 - S₁₋₃ : LIMITER SWITCH (OFF POSITION)
 - S₁₋₄ : DOLBY SWITCH (OFF POSITION)
 - S₁₋₅ : CHROME TAPE DETECTOR (NO HOLE POSITION)
 - S₁₋₆ : MPX FILTER SWITCH (OFF POSITION)
 - S₁₋₇ : MEMORY SWITCH (OFF POSITION)
 - S₁₋₈ : PLAY SWITCH (OFF POSITION)
 - S₁₋₉ : REW SWITCH (OFF POSITION)
 - S₁₋₁₀ : FAST FORWARD SWITCH (OFF POSITION)
 - S₁₋₁₁ : REC SWITCH (OFF POSITION)
 - S₁₋₁₂ : CASSETTE DETECTOR SWITCH (NO HALF POSITION)
 - S₁₋₁₃ : SENSING SWITCH
 - S₁₋₁₄ : COUNTER SWITCH
 - S₂ : PAUSE SWITCH (OFF POSITION)
 - S₃ : ERASE PREVENT DETECTOR SWITCH (NOT RECORDING POSITION)

RESISTOR
OTHERWISE NOTED K : K Ω M : M Ω

CAPACITORS
UNLESS OTHERWISE NOTED P : pF

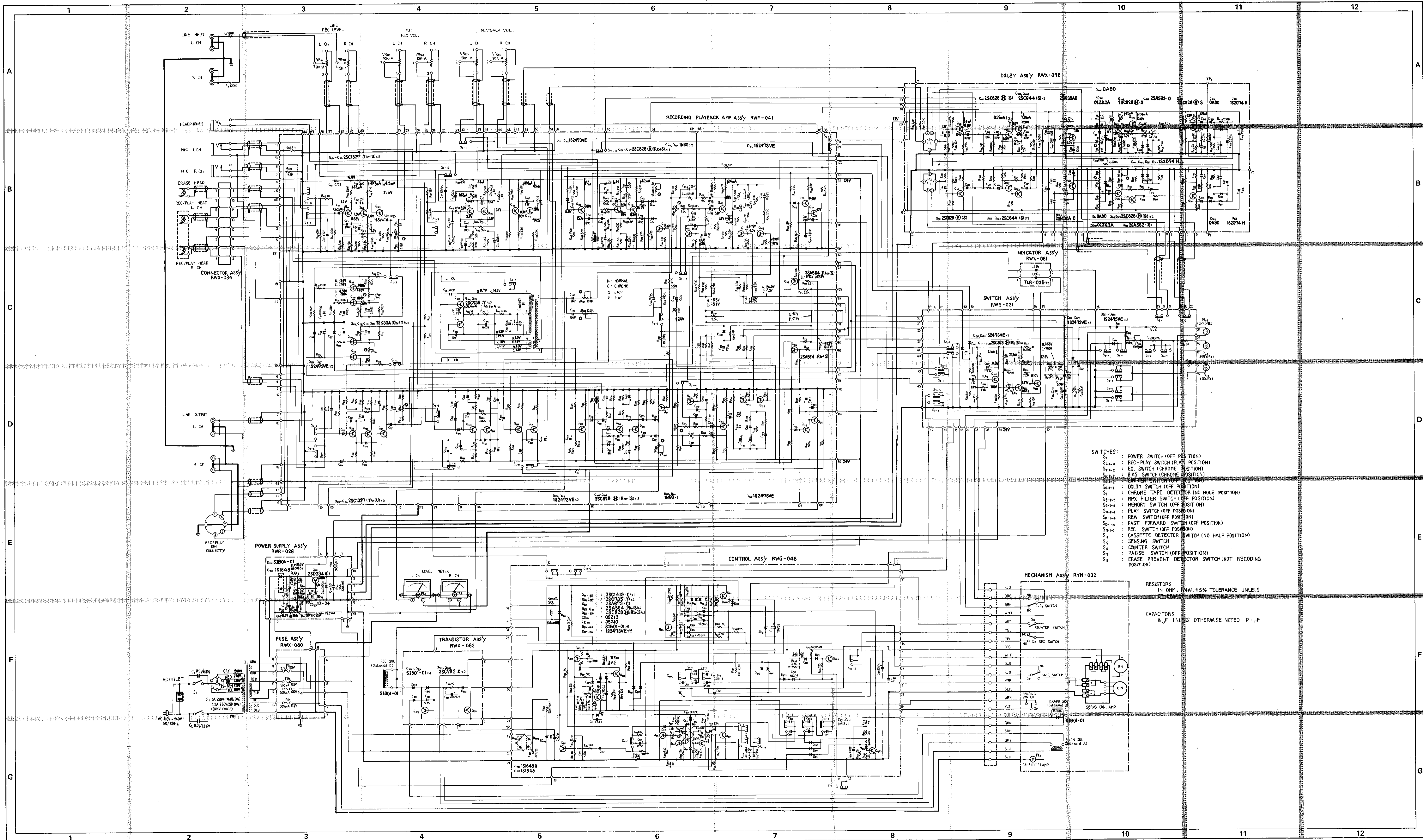

- SWITCHES:
- S₁ : POWER SWITCH (OFF POSITION)
 - S₂₋₁₋₈ : REC-PLAY SWITCH (PAUSE POSITION)
 - S₂₋₂ : ED SWITCH (CHROME POSITION)
 - S₂₋₃ : BIAS SWITCH (CHROME POSITION)
 - S₂₋₄ : EJECTOR SWITCH (OFF POSITION)
 - S₂₋₅ : DOLBY SWITCH (OFF POSITION)
 - S₂₋₆ : CHROME TAPE DETECTOR (NO HOLE POSITION)
 - S₂₋₇ : HPX FILTER SWITCH (OFF POSITION)
 - S₂₋₈ : MEMORY SWITCH (OFF POSITION)
 - S₂₋₉ : PLAY SWITCH (OFF POSITION)
 - S₂₋₁₀ : REW SWITCH (OFF POSITION)
 - S₂₋₁₁ : FAST FORWARD SWITCH (OFF POSITION)
 - S₂₋₁₂ : REC SWITCH (OFF POSITION)
 - S₂₋₁₃ : CASSETTE DETECTOR SWITCH (NO HALF POSITION)
 - S₂₋₁₄ : SENSING SWITCH
 - S₂₋₁₅ : COUNTER SWITCH
 - S₂₋₁₆ : PAUSE SWITCH (OFF POSITION)
 - S₂₋₁₇ : ERASE PREVENT DETECTOR SWITCH (NOT RECORDING POSITION)

RESISTORS
IN OHM ±5% TOLERANCE UNLESS

CAPACITORS
IN μF UNLESS OTHERWISE NOTED P: μF