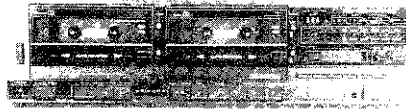

Service Manual

REPAIR & ADJUSTMENTS

**ORDER NO.
ARP1028-0**
STEREO DOUBLE CASSETTE TAPE DECK

CT-1270WR(BK)

MODEL CT-1270WR (BK) COMES IN SIX VERSIONS DISTINGUISHED AS FOLLOWS:

Type	Power requirement	Destination
KU	AC120V only	U.S.A. model
KC	AC120V only	Canada model
HEM	AC220V, 240V (switchable)	European continent model
HB	AC220V, 240V (switchable)	United Kingdom model
D	AC120V, 220V, 240V (switchable)	General export model
D/G	AC120V, 220V, 240V (switchable)	U.S. Military model

- This service manual is applicable to the KU type.
- As to the KC, HEM and HB types, please refer to the additional service manual (ARP1029).
- As to the circuit and mechanism descriptions, please refer to the CT1270WR (BK) service manual (ARP1027).
- As to the D and D/G types, please refer to the additional service manual (ARP1030).
- Ce manuel d'instruction se réfère au mode de réglage, en français.
- Este manual de servicio trata del método ajuste escrito en español.

1. SAFETY INFORMATION	2	8. P.C. BOARDS CONNECTION DIAGRAM	23
2. SPECIFICATIONS	3	9. SCHEMATIC DIAGRAM	27
3. FRONT PANEL FACILITIES	4	10. ELECTRICAL PARTS LIST	31
4. DISASSEMBLY	7	11. ADJUSTMENTS	35
5. PARTS LOCATION	11	RÉGLAGE	42
6. EXPLODED VIEWS AND PARTS LIST	13	AJUSTES	49
7. PACKING	22		

PIONEER ELECTRONIC CORPORATION 4-1, Meguro 1-Chome, Meguro-ku, Tokyo 153, Japan
PIONEER ELECTRONICS SERVICE INC. P.O. Box 1780, Long Beach, California 90801, U.S.A.
 TEL: (213) 480-5700

PIONEER ELECTRONIC (EUROPE) N.V. Keetberglaan 1, 2710 DAVENNE, Belgium TEL: (32) 7 75 80 06

PIONEER ELECTRONICS AUSTRALIA PTY. LTD. 178-184 Boundary Road, Brisbane, Victoria 4170, Australia
 TEL: (03) 580-9911

1. SAFETY INFORMATION

1. SAFETY PRECAUTIONS

The following check should be performed for the continued protection of the customer and service technician.

LEAKAGE CURRENT CHECK

Measure leakage current to a known earth ground (water pipe, conduit, etc.) by connecting a leakage current tester such as Simpson Model 229-2 or equivalent between the earth ground and all exposed metal parts of the appliance (input/output terminals, screwheads, metal overlays, control shaft, etc.). Plug the AC line cord of the appliance directly into a 120V AC 60Hz outlet and turn the AC power switch on. Any current measured must not exceed 0.5mA.

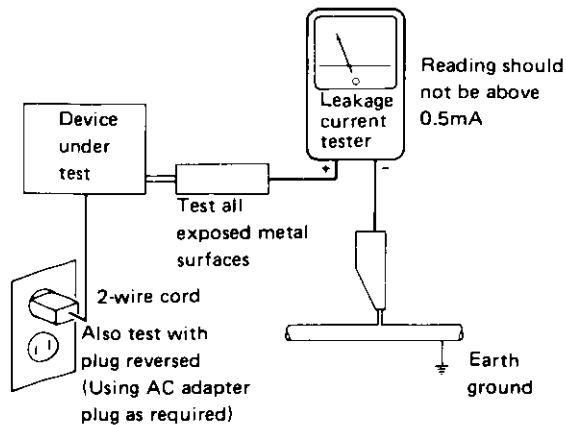

AC Leakage Test

ANY MEASUREMENTS NOT WITHIN THE LIMITS OUTLINED ABOVE ARE INDICATIVE OF A POTENTIAL SHOCK HAZARD AND MUST BE CORRECTED BEFORE RETURNING THE APPLIANCE TO THE CUSTOMER.

2. PRODUCT SAFETY NOTICE

Many electrical and mechanical parts in the appliance have special safety related characteristics. These are often not evident from visual inspection nor the protection afforded by them necessarily can be obtained by using replacement components rated for voltage, wattage, etc. Replacement parts which have these special safety characteristics are identified in this Service Manual.

Electrical components having such features are identified by marking with a Δ on the schematics and on the parts list in this Service Manual.

The use of a substitute replacement component which does not have the same safety characteristics as the PIONEER recommended replacement one, shown in the parts list in this Service Manual, may create shock, fire, or other hazards.

Product Safety is continuously under review and new instructions are issued from time to time. For the latest information, always consult the current PIONEER Service Manual. A subscription to, or additional copies of, PIONEER Service Manual may be obtained at a nominal charge from PIONEER.

2. SPECIFICATIONS

Systems	4 track, 2-channel stereo
Heads	“Hard Permalloy” recording/playback head x 1 “Hard Permalloy” playback head x 1 “Ferrite” erasing head x 1
Motor	DC servo capstan motor x 2
Wow and Flutter	No more than 0.07% (WRMS) No more than $\pm 0.19\%$ (DIN)
Fast winding Time	Approximately 110 seconds (C-60 tape)
Frequency Response	
-20 dB recording:	
Normal tape	20 to 15,000 Hz
Chrome tape	20 to 15,500 Hz
Metal tape	20 to 16,000 Hz
0 dB recording:	
Normal tape	20 to 10,000 Hz
Chrome tape	20 to 11,000 Hz
Metal tape	20 to 15,000 Hz
Signal-to-Noise Ratio	
Dolby NR OFF	More than 57 dB
Noise Reduction Effect	
Dolby NR B type ON	More than 10 dB (at 5 kHz)
Dolby NR C type ON	More than 19 dB (at 5 kHz)
Harmonic Distortion	No more than 0.7% (0 dB)
Input (Sensitivity)	
LINE (INPUT)	70 mV (Input impedance 100 k Ω)
Output (Reference level)	
LINE (OUTPUT)	316 mV (Output impedance 3.9 k Ω)
HEADPHONES	45 mV (Load impedance 8 Ω)

Subfunctions

- Relay playback (Deck I \leftrightarrow Deck II)
- Synchronized copy start
- High-speed and normal-speed tape copying (Deck I \rightarrow Deck II)
- Dolby NR B/C types
- Auto tape selector (Deck I)
- 5 segments/channel LED level meter
- Music Scan (Cue and Review) (Deck I)
- Full automatic stop function
- Timer stand-by function (Unattended recording: Deck II) (Wake-up playback: Deck I and Deck II)
- One-Touch recording
- 3-digit mechanical tape counter

Miscellaneous

Power Requirements

U.S., Canadian models	AC 120 V, 60 Hz
European model	AC 220 V, 50/60 Hz
U.K. model	AC 240 V, 50/60 Hz
U.S. military, other destination models	AC 120 V/220 V/240 V, 50/60 Hz (switchable)

Power Consumption

U.S., Canadian models	18 W
European, U.K. models	21 W
U.S. military, other destination models	16 W

Dimensions	420 (W) x 115 (H) x 262 (D) mm 16-9/16 (W) x 4-1/2 (H) x 10-5/16 (D) in
------------------	--

Weight (without package)	5 kg (11 lb)
--------------------------------	--------------

Accessories

Operating instructions	1
Connection cord with pin plugs	2

NOTE:

Specifications and design subject to possible modifications without notice due to improvements.

3. FRONT PANEL FACILITIES

POWER switch

NOTE:

The unit's POWER switch is designed to select the transformer's secondary and so even at the STAND-BY position, the unit's circuitry will work as long as the power cord is connected to power outlet. Disconnect the power cord from the power outlet when you do not plan to use the unit for a long period of time.

Deck I Reverse MODE switch

(↶) position

Set to this position to play back both sides of the cassette. When the tape reaches the end during playback in the FWD direction, the deck will automatically reverse directions and playback the other side of the cassette. When the tape reaches the end in the REV direction, the deck will stop automatically. Start playback from the FWD direction to play back both sides of the tape automatically.

(↷) position

Set to this position to play back both sides of the tape continuously.

Deck II Reverse MODE switch

(↶) position

Set to this position for playback or recording of only one side of the cassette. The deck will stop automatically when the tape reaches the end.

(↷) position

Set to this position for playback or recording of both sides of the cassette. When the tape reaches the end during playback (or recording) in the FWD direction, the deck will automatically reverse directions and play back (or record) the other side of the cassette. When the tape reaches the end in the REV direction, the deck will stop automatically. Playback (or recording) must be started from the FWD direction in order for the auto-reverse function to work.

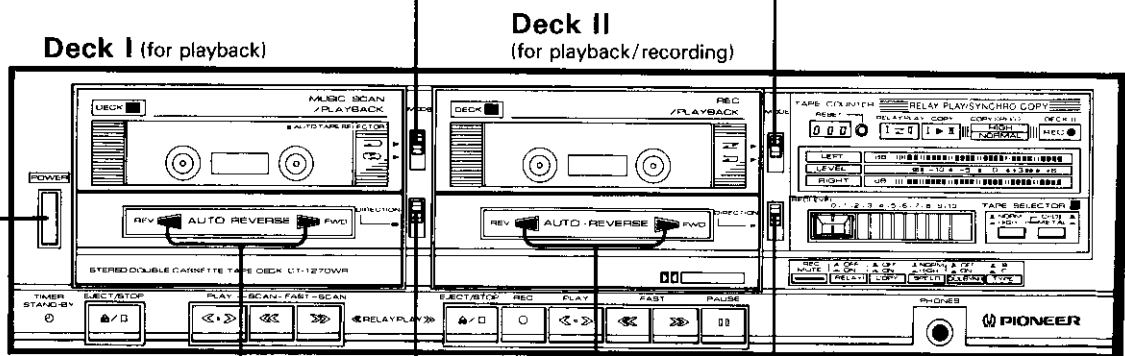

Deck I Tape direction indicators

Indicate direction of tape playback.
 FWD: Side A (visible side) playback
 REV : Side B (side not visible) playback

Deck II DIRECTION lever

Use to change the playback/recording direction of Deck II. Each time this lever is pushed down the playback/ recording direction will be changed. (This lever cannot be locked.)

Deck I DIRECTION lever

Use to change the playback direction of Deck I. Each time this lever is pushed down the playback direction will be changed. (This lever can not be locked.)

Deck II tape direction indicators

Show direction of tape playback or recording
 FWD: Side A (visible side) playback/recording
 REV : Side B (side not visible) playback/recording

REC LEVEL control

Tape COPY switch (OFF/ON)

Press for tape copying. This switch should always be in the OFF (■) position when not copying tapes. If the COPY switch is set to the ON (■) position, it will not be possible to record signals from the LINE INPUT terminals. Also, when the COPY switch is in the ON (■) position, Deck I will not operate unless Deck II is in the REC or REC/PAUSE mode.

RELAY play switch (OFF/ON)

When the RELAY play switch is in the ON (■) position, relay play can be performed between Deck I and Deck II. When the RELAY play switch is in the ON (■) position, if the PLAY button of either deck or the REC button (Deck II only) is pressed, the PLAY, FF, and REW buttons of the other deck will not function.

Deck II REC MUTE button

During recording on Deck II, the input signal will be cut while this button is held depressed, creating a blank interval on the tape.

COPY SPEED switch (NORM/HIGH)

HIGH (■): When the unit is in the tape copy mode, pressing this switch will cause high speed copying to take place.
NORM (■): Tapes are copied at the normal speed.

LEVEL meter

Deck II REC indicator

Lights when Deck II is in the record mode.

COPY indicator

Lights when Deck I and Deck II are in the tape copy mode.

RELAY PLAY indicator

Lights when Deck I and Deck II are in the relay play mode.

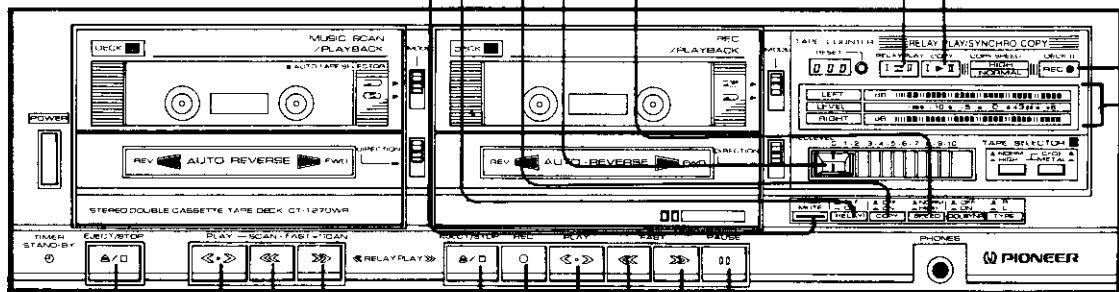

Deck I PLAY button

Playback on Deck I starts when this button is pressed. Playback direction is shown by the Deck I tape direction indicators (FWD or REV).

Deck I FAST/SCAN buttons

When one of these buttons is pressed, the tape in Deck I is wound rapidly in the direction shown by the arrow above the button pressed. When pressed during playback, the tape will be played back rapidly. This allows you to cue or review the tape to locate a desired position.

Deck I EJECT/STOP button

The cassette compartment door will open when this button is pressed while the tape is stopped. Pressing it while the tape is running will stop the tape.

Deck II EJECT/STOP button

The cassette compartment door will open when this button is pressed while the tape is stopped. Pressing it while the tape is running will stop the tape.

Deck II PAUSE button

Tape travel will be stopped temporarily during recording or playback on Deck II when this button is pressed.

Deck II FAST buttons

When one of these buttons is pressed, the tape will be wound rapidly in the direction of the arrow above the button pressed.

Deck II PLAY button

Playback on Deck II starts when this button is pressed. Playback direction is shown by the Deck II tape direction indicators (FWD or REV).

Deck II REC button

When the REC button is pressed, the PLAY button will also be engaged automatically and recording on Deck II will start. It will not be possible to depress this button if the accidental erasure prevention tabs on the cassette have been removed, or if the tape is not loaded properly. Never try to force it.

TAPE SELECTOR II switches

The selectors allow the bias and equalization characteristics during recording, and equalization characteristics during playback, to be selected on Deck II in accord with the type of tape used.

Normal tape:

Release the left-hand switch to the "out" position (NORM).

CrO₂ tape:

Press the left-hand switch and set it to the "in" position (HIGH) and release the right-hand switch to the "out" position (CrO₂).

Metal tape:

Press both the left and right-hand switches to the "in" position (HIGH, METAL).

NOTE:

Deck I is provided with an automatic tape selector mechanism.

Tape counter RESET button

Deck II TAPE COUNTER

Three-digit counter indicates the current position on the tape in Deck II.

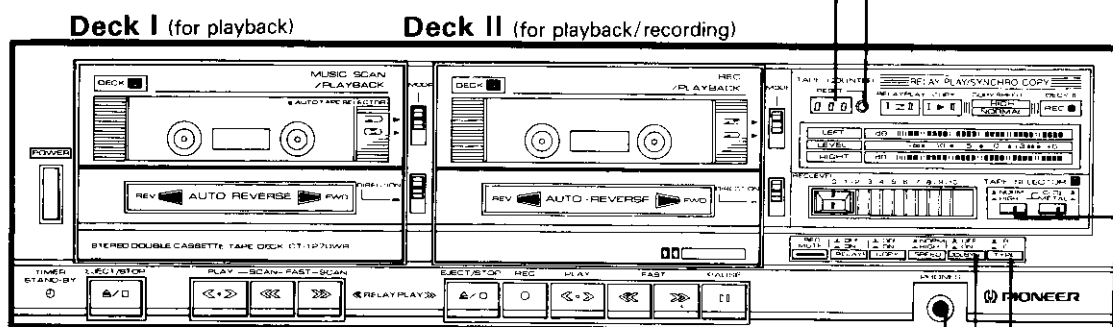

PHONES jack

DOLBY B-C NR switches

Make sure that the switch is set to the same setting when playing back tapes recorded with the Dolby B or C type noise reduction system.

Dolby NR OFF:

Release the left-hand switch to the "out" position (OFF).

Dolby B-type NR ON:

Press the left-hand switch and set it to the "in" position (ON) and release the right-hand switch to the "out" position (B).

Dolby C-type NR ON:

Press the left and right-hand switches to the "in" position (ON, C).

- Noise reduction manufactured under license from Dolby Laboratories Licensing Corporation.
- "Dolby" and the double-D symbol are trademarks of Dolby Laboratories Licensing Corporation.

4. DISASSEMBLY

4.1 Removal of the Bonnet.

1. Remove the three screws ① and remove the bonnet.

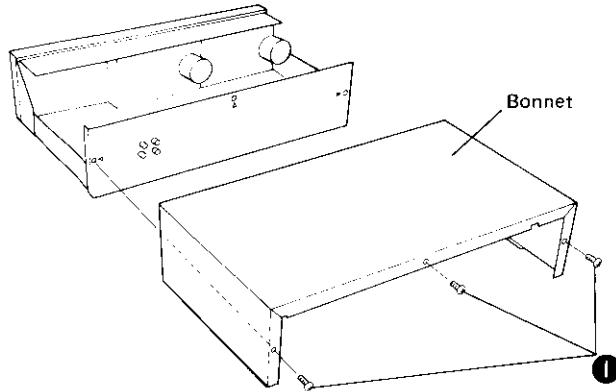

Fig. 4-1 Removal of the bonnet

4.2 Removal of the Mechanical Unit

1. Remove the three screws ② and take off the top plate.

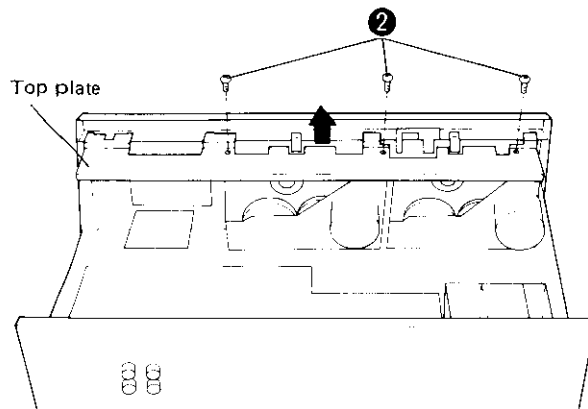

Fig. 4-2 Removal of the top plate.

2. Remove the switch lever and SW connector spring from DECK 2 (RYM-203).

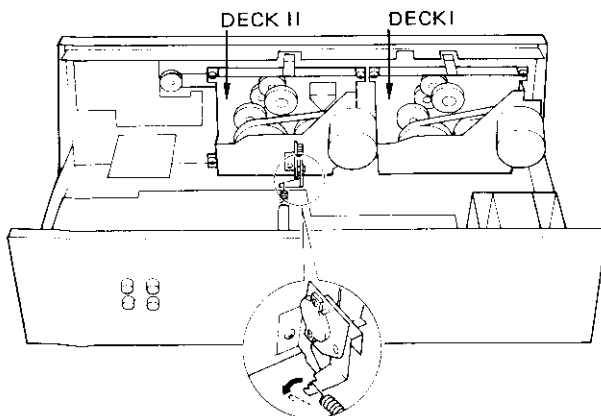

Fig. 4-3 Removal of the SW connector spring

3. Remove the 5 screws ③ and take off the front panel.

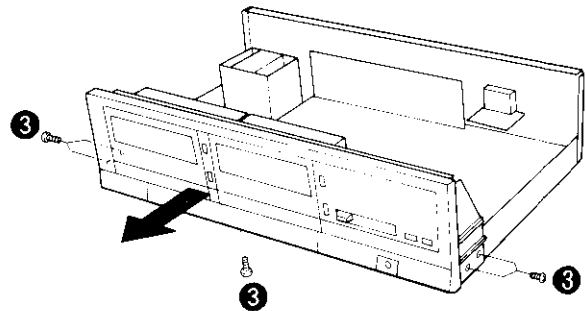

Fig. 4-4 Removal of the front panel

4. Pass the counter belt from the counter around a boss in DECK 2. Remove the eight screws ④.

If there is difficulty in removing screws, first take off the connector and remove the front panel.

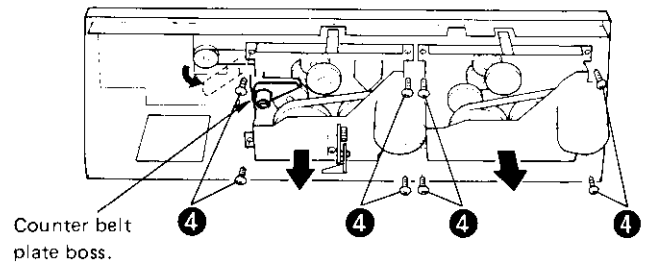

Fig. 4-5 Removal of the mechanical unit

4.3 Belt Replacement Procedure.

1. First remove the mechanical unit from the main body. (See 4-2 for removal of the mechanical unit).
2. Remove the angular belt (FR belt) from the mechanical unit.
3. Remove the single screw ⑤. Remove the REC SW bracket. (DECK 2 (RYM-203) only).

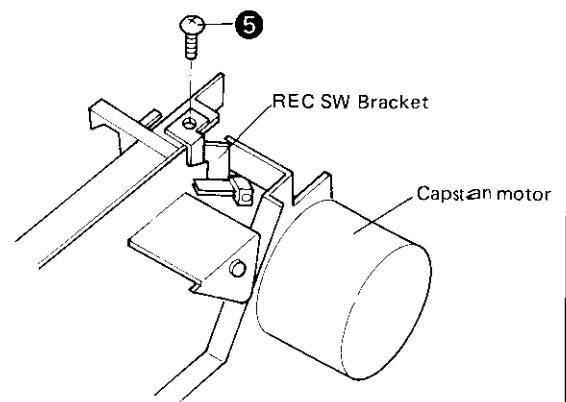

Fig. 4-6 Removal of the REC SW Bracket

4. Remove the 3 side screws **6**. Remove the motor bracket from the mechanical chassis.

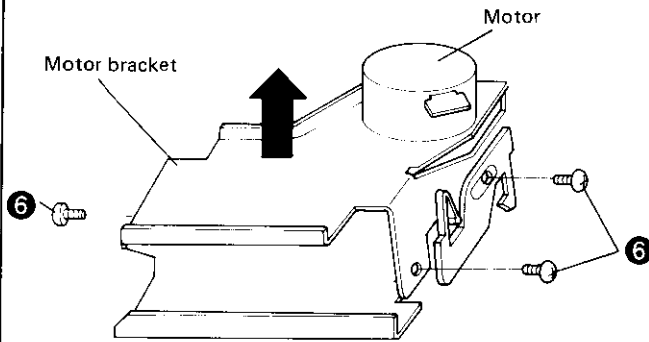

Fig. 4-7 Removal of the motor bracket

Note: Make sure that the positions of the motor and motor pulley (H) are as shown in the figure below.

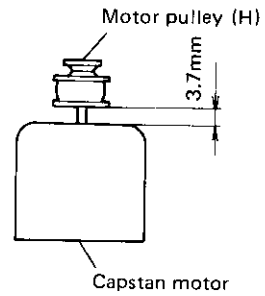

Fig. 4-10 Diagram showing the positions of the motor and motor pulley (H)

5. Replace the belt. Procedure is the reverse of removal. Note: For DECK 1 (RYM-202), Item 3 is shortened.

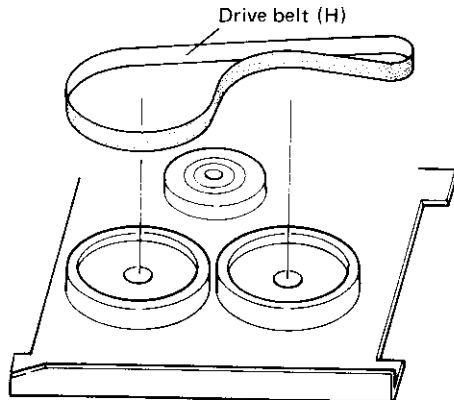

Fig. 4-8 Replacement of the drive belt (H)

4. Remove the three screws **7**. Remove the motor from the motor bracket and replace.

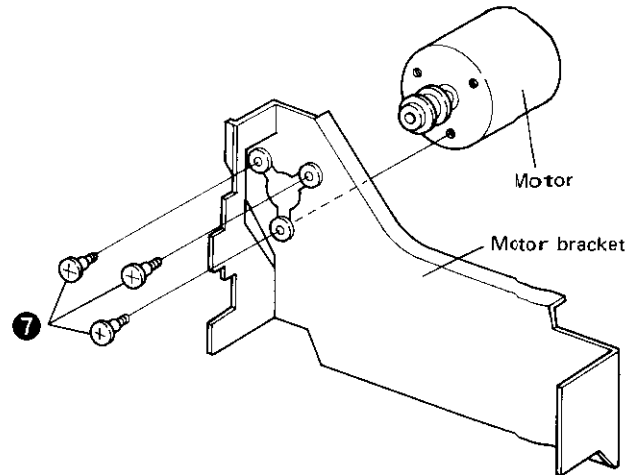

Fig. 4-11 Replacement of the motor

4.4 Motor replacement procedure.

1. Remove the mechanical unit from the main body. (See 4-2 for removal of the mechanical unit)
2. Remove the motor bracket from the mechanical chassis. (See 4-3. Belt replacement procedure).
3. Remove the motor lead by using a soldering iron.

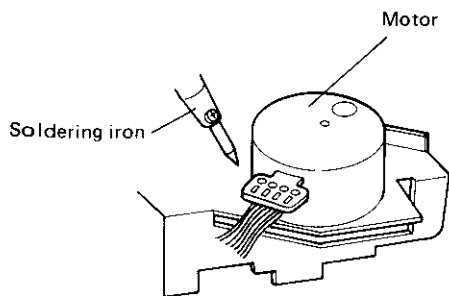
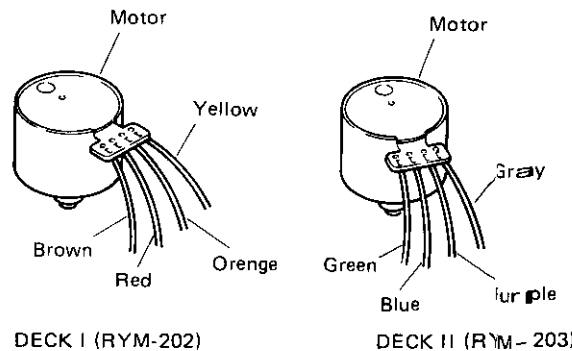

Fig. 4-9 Removal of the motor lead

5. Assembly is carried out in reverse order to disassembly. (Make sure that the motor has the correct orientation on installation).
6. Carry out tape speed adjustments. (See 11-3 Tape speed adjustments)



DECK I (RYM-202)

DECK II (RYM-203)

Fig. 4-12 Motor P.C.B wiring diagram

4.5 Head Replacement Procedure.

1. Remove the mechanical unit from the main body.
2. Remove each knob from the mechanical unit.

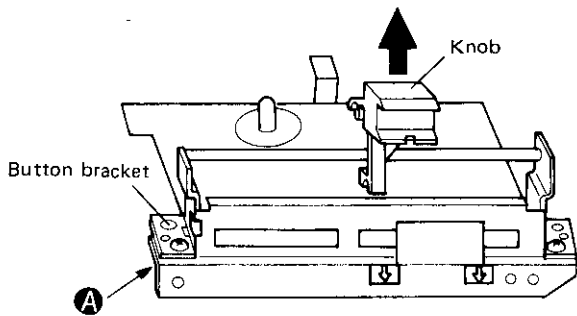

Note: There is a spring attached to part **A**. If this spring is released, re-insertion can be extremely difficult so avoid removal of the button bracket from the mechanical unit.

Fig. 4-13 Removal of the knobs

3. Remove the wire band (Monofilament) from the head lead.

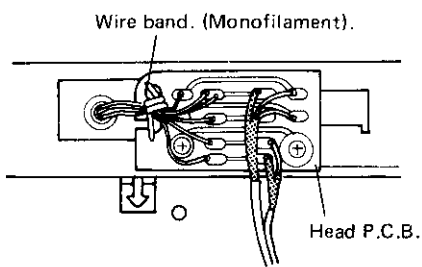

Fig. 4-14 Removal of the wire hand (Monofilament)

4. Remove the head lead from the head P.C.B. with a soldering iron.

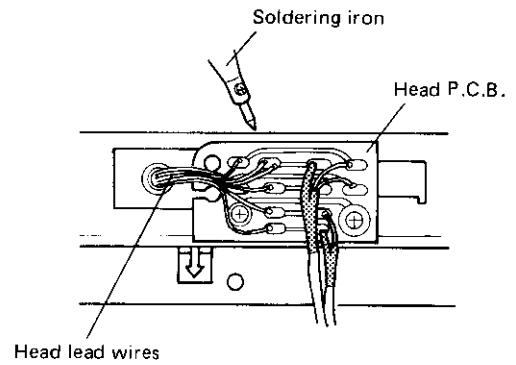

Fig. 4-15 Removal of the head lead

5. Remove the two screws **8** which secure the rotary head assembly to the head chassis assembly.

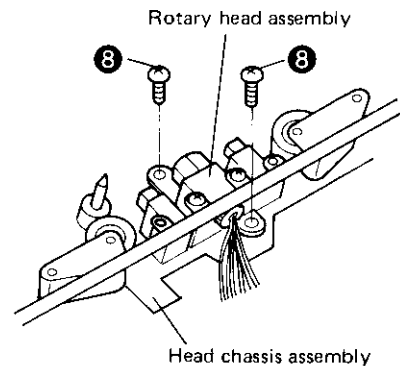

Fig. 4-16 Removal of the rotary head assembly

6. Slide the head chassis forward with a finger. Remove the rotary head assembly and replace.

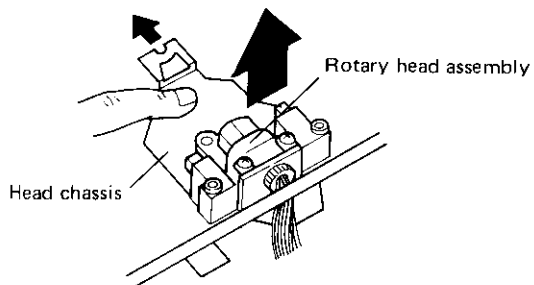
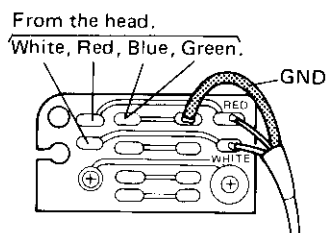
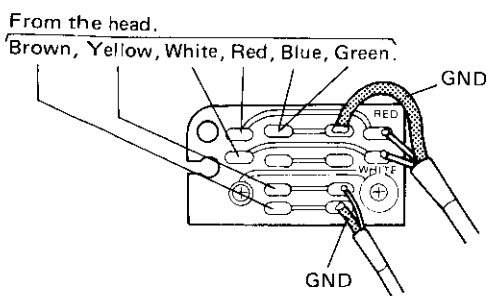

Fig. 4-17 Head replacement procedure

7. Assemble in reverse order to disassembly. (Note the orientation of the rotary head assembly).



DECK I (RYM-202) head P.C.B.



DECK II (RYM-203) head P.C.B.

Fig. 4-18 Head P.C.B wiring diagram

3. PARTS LOCATION

- * The classification of parts is based on the classification of the parts in the parts list.
- * The classification of parts is based on the classification of the parts in the parts list.
- * The classification of parts is based on the classification of the parts in the parts list.
- * **** GENERAL NOTES FASTER THAN ***
- * The classification of parts is based on the classification of the parts in the parts list.
- * The classification of parts is based on the classification of the parts in the parts list.

Figure 3-1-1

Q101
RAC101

Q102
RAC102

Q103
RAC103

Q104
RAC104

Q105
RAC105

Q106
RAC106

Q107
RAC107

Q108
RAC108

Q109
RAC109

Q110
RAC110

Q111
RAC111

Q112
RAC112

Q113
RAC113

Q114
RAC114

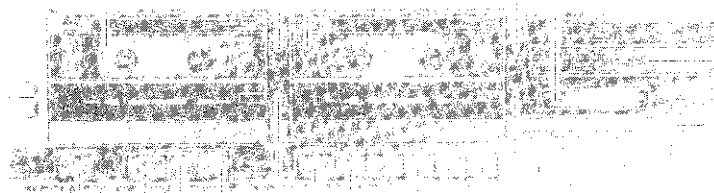

Q101
RAC101

Q102
RAC102

Q103
RAC103

Q104
RAC104

Q105
RAC105

Q106
RAC106

Q107
RAC107

Q108
RAC108

Q109
RAC109

Q110
RAC110

Q111
RAC111

Q112
RAC112

Q113
RAC113

Q114
RAC114

Rear Panel View

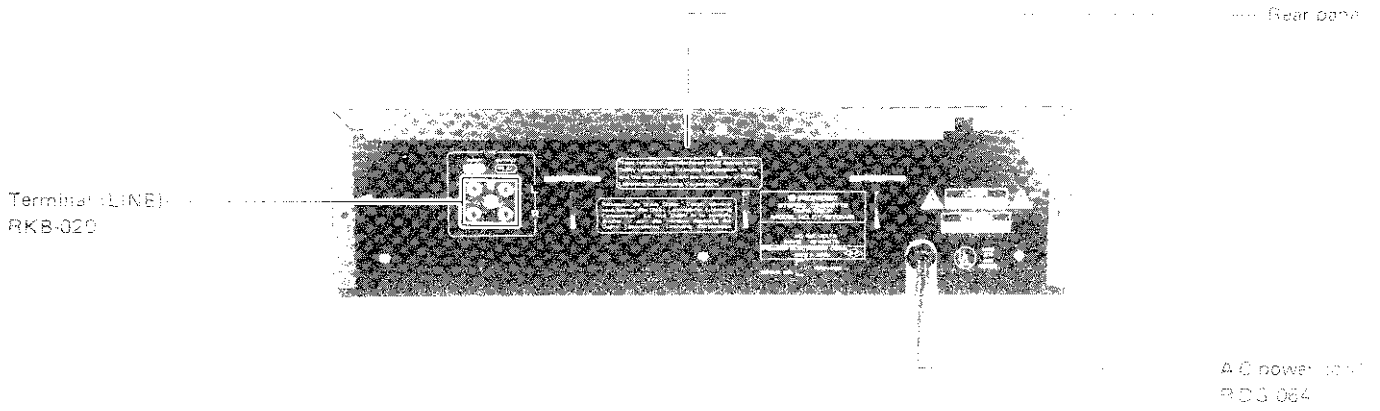

Top View

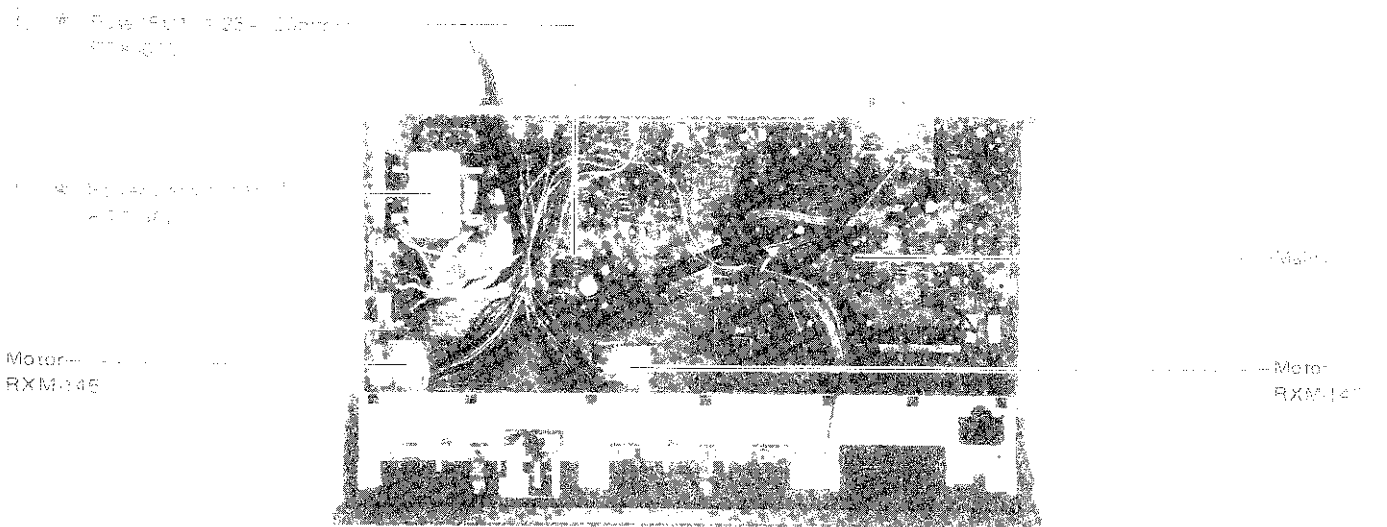

6. EXPLODED VIEWS AND PARTS LIST

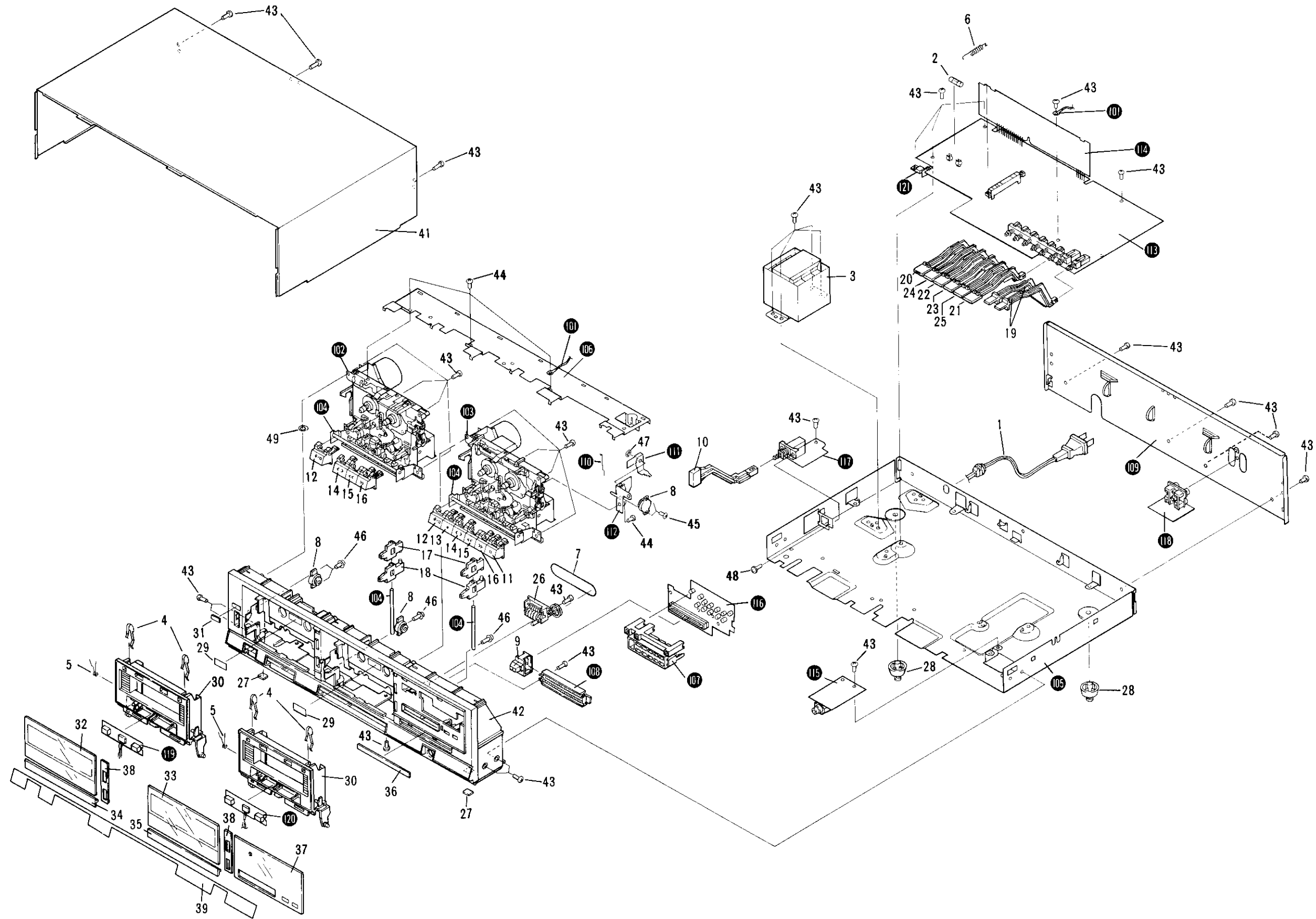

Part List

Mark	No
	1
▲	2
★	3
★	4
	5
	6
	7
	8
	9
	10
	11
	12
	13
	14
	15
	16
	17
	18
	19
	20
	21
	22
	23
	24
	25
	26
	27
	28
	29
	30
	31
	32
	33
	34
	35
	36
	37
	38
	39
	40
	41
	42
	43

3

4

5

6

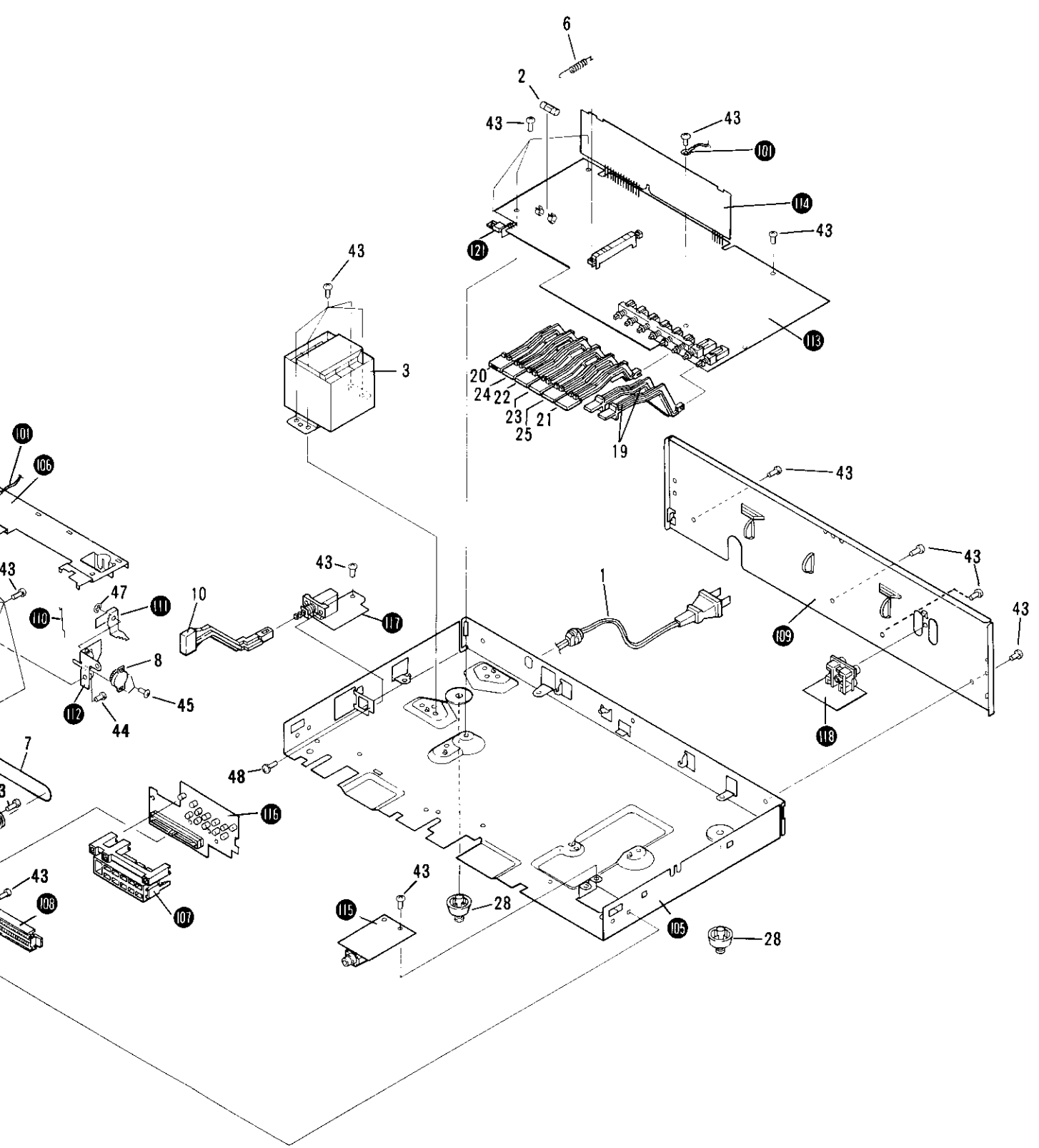

NOTES:

- Parts without part number cannot be supplied.
- The \triangle mark found on some component parts indicates the importance of the safety factor of the part. Therefore, when replacing, be sure to use parts of identical designation.
- For your Parts Stock Control, the fast moving items are indicated with the marks **★★** and **★**.
★★ GENERALLY MOVES FASTER THAN ★
 This classification shall be adjusted by each distributor because it depends on model number, temperature, humidity, etc.
- Parts marked by "⊙" are not always kept in stock. Their delivery time may be longer than usual or they may be unavailable.

A

B

C

D

Part List of Exploded View (Exterior Components)

Mark	No.	Part No.	Description	Mark	No.	Part No.	Description
	1	RDG-064	AC Power cord		36	RAH-833	Knob plate
\triangle ★★	2	REK-073	Fuse (FU1: 1.25A 20mm)		37	RAH-834	Display panel
★	3	RTT-462	Power transformer (T1)		38	RAH-835	Mode panel
	4	RBK1001	Harf pressure spring		39	RAH-836	Function panel
	5	RBL-222	Door spring		40	REC-371	Binder
	6	RBL-181	Switch rod spring		41	RNA-806	Bonnet
	7	REB-555	Counter belt		42	RXX-538	Front panel assembly
	8	REC-436	Door damper		43	BBZ30P080FMC	Screw
	9	RAC-680	Knob (VR)		44	BBZ26P060FMC	Screw
	10	RAC-682	Knob (POWER)		45	PBZ20P060FZK	Screw
	11	RAC-718	Pause button (PAUSE)		46	ABZ30P080FMC	Screw
	12	RAC-719	Stop button (STOP)		47	YE30FUC	E-ring
	13	RAC-720	REC button (REC)		48	PMA30P060FMC	Screw
	14	RAC-721	Play button (PLAY)		49	WT42D070D013	Washer
	15	RAC-722	REW button (REW)		101		Earth lead assembly
	16	RAC-723	FF button (FF)		102		Mechanism assembly
	17	RAC-724	Mode knob (MODE)		103		Mechanism assembly
	18	RAC-725	Direction knob		104		Knob shaft
	19	RAC-726	Tape knob (TAPE)		105		Main chassis
	20	RAC-727	Mute knob (MUTE)		106		Top stay
	21	RAC-728	Dolby knob (DOLBY B-C NR)		107		LED Holder A
	22	RAC-729	Copy knob (COPY)		108		VR knob guide
	23	RAC-730	Speed knob (COPY SPEED)		109		Rear panel
	24	RAC-731	Relay knob (RELAY)		110		Rod spring
	25	RAC-732	Dolby knob		111		Select lever
	26	RAW-221	Counter		112		REC select bracket assembly
	27	REB-513	Stopper		113		Main unit
	28	REC-435	Leg assembly		114		Sub unit
	29	REE-113	Remain display paper		115		Headphone unit
	30	RNM-186	Door		116		Display unit
	31	RAH-804	Power panel		117		Power switch unit
	32	RAH-829	Door panel (L)		118		Jack unit
	33	RAH-830	Door panel (R)		119		Door display unit 1
	34	RAH-831	Door plate (L)		120		Door display unit 2
	35	RAH-832	Door plate (R)		121		Transistor unit

3

4

5

6

14

Tape Transport Unit (Deck II) : side

A

B

C

D

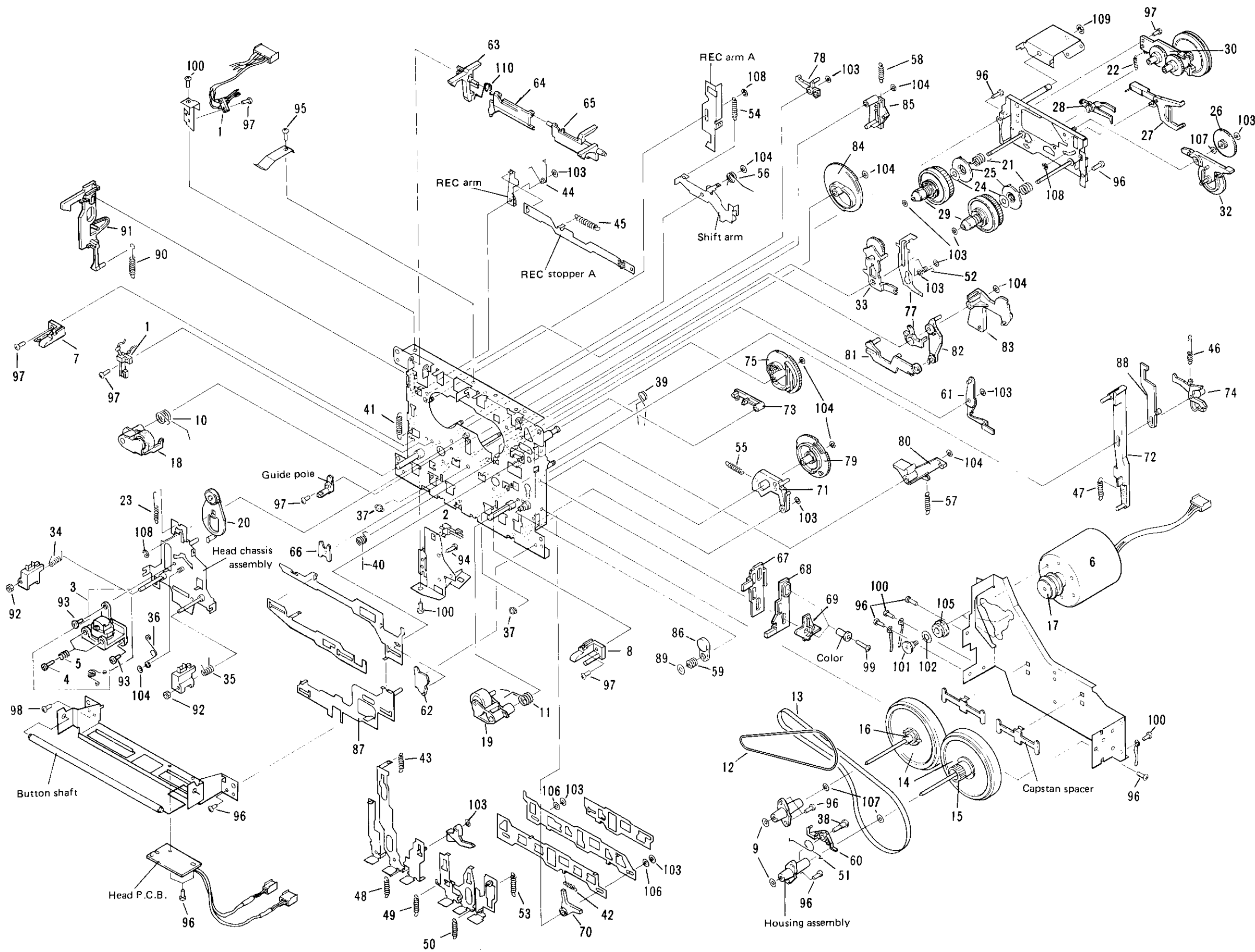

Parts List of Ta

Mark	No.	Part
	1	RSN-
	2	RSN-
	3	RXC
	4	RBA-
	5	RBL-
	6	RXM
	7	RNM
	8	RNM
	9	RBF-
	10	RBL-
	11	RBL-
	12	REB-
	13	REB-
	14	RNG
	15	RNM
	16	RNM
	17	RNM
	18	RXC
	19	RXC
	20	RXC
	21	RBL-
	22	RBL-
	23	RBL-
	24	RED
	25	RNM
	26	RNM
	27	RNM
	28	RNM
	29	RXC
	30	RXC
	31	
	32	RXC
	33	RXC
	34	RBL-
	35	RBL-
	36	RBL-
	37	RBL-
	38	RBA-
	39	RBL-
	40	RBL-
	41	RBL-
	42	RBL-
	43	RBL-
	44	RBL-
	45	RBL-
	46	RBL-
	47	RBL-
	48	RBL-
	49	RBL-
	50	RBL-
	51	RBL-
	52	RBL-
	53	RBL-
	54	RBL-
	55	RBL-

A

B

C

D

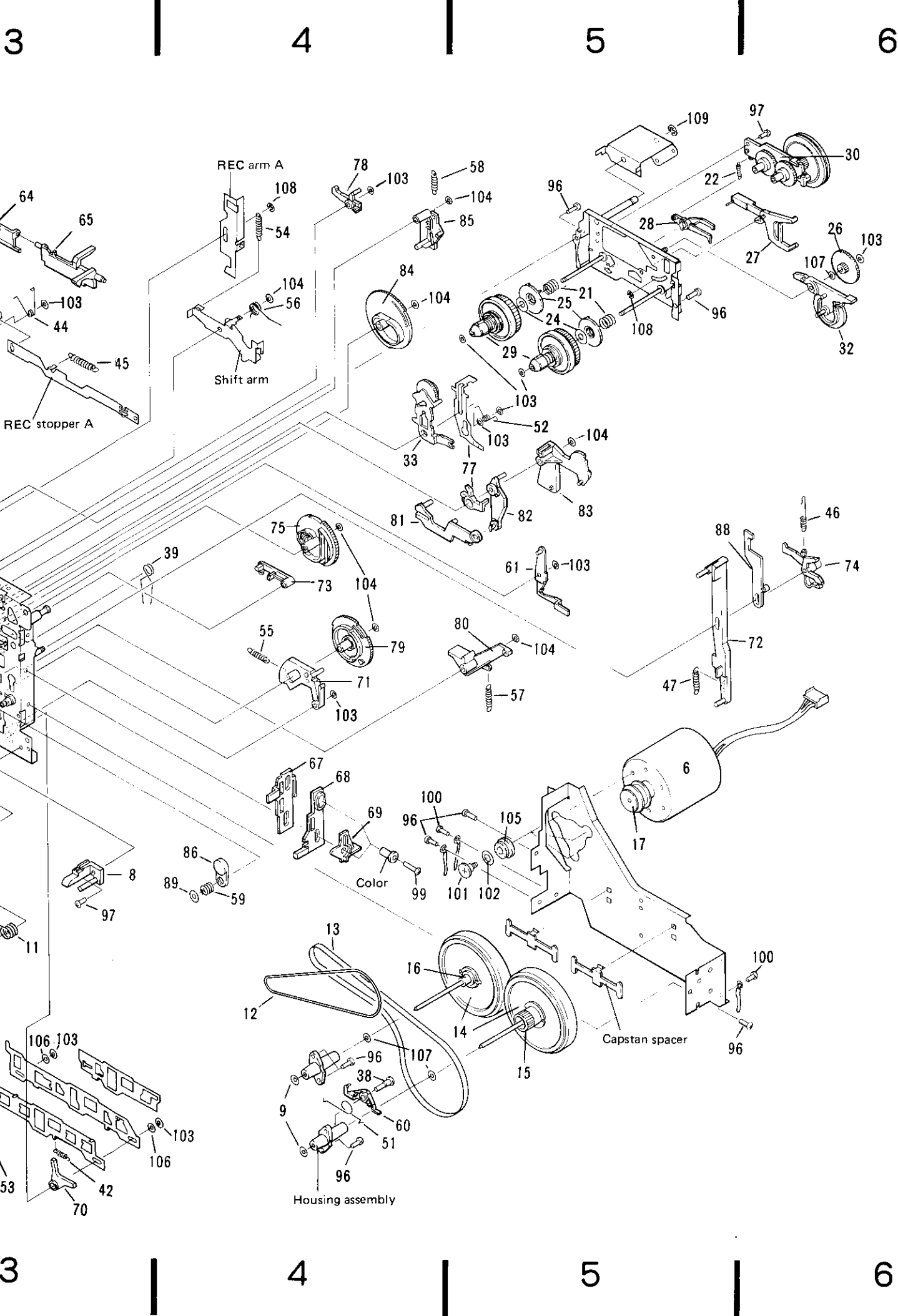

Parts List of Tape Transport Unit (Deck II: side)

Mark	No.	Part No.	Description	Mark	No.	Part No.	Description
A	1	RSN-040	Leaf switch (S1502, S1503 REC)	56	RBL-209	Shift arm SP	
	2	RSN-042	Leaf switch (S1501 PLAY)	57	RBL-210	Shift arm R-SP (B)	
	3	RXC-173	R-Head assembly	58	RBL-211	G lock arm (P) SP-C	
	4	RBA-098	Azimuth screw	59	RBL-212	Pause cam SP	
	5	RBL-216	Azimuth spring	60	RNM-187	FR arm (B)	
	6	RXM-145	Motor	61	RNM-192	REC lever (B)	
	7	RNM-195	Cassette guide (L)	62	RNM-193	1 mode arm	
	8	RNM-196	Cassette guide (R)	63	RNM-227	REC sensor (L)	
	9	RBF-050	Washer	64	RNM-228	REC sensor (M)	
	10	RBL-184	Roller spring (L)	65	RNM-229	REC sensor (R)	
	11	RBL-185	Roller spring (P)	66	RNM-230	Idler arm	
	12	REB-551	FR belt (H)	67	RNM-231	Mode lever	
	13	REB-552	Drive belt (H)	68	RNM-232	Direction lever	
	14	RNG-361	Flywheel (C)	69	RNM-233	Direction ST arm	
	15	RNM-199	Flywheel gear	70	RNM-234	Cam cancel lever	
B	16	RNM-200	Flywheel collar	71	RNM-235	G lock arm (FR)	
	17	RNM-203	Motor puller (H)	72	RNM-236	Auto stop lever	
	18	RXC-162	Roller arm assembly (L)	73	RNM-238	AS direction arm	
	19	RXC-163	Roller arm assembly (R)	74	RNM-239	Direction arm	
	20	RXC-175	Idler arm assembly	75	RNM-240	RV cam gear	
	21	RBL-186	Back T Spring (B)	76	RNM-241	Play arm	
	22	RBL-187	Auto arm spring	77	RNM-242	Brake arm (L)	
	23	RBL-188	Idler spring	78	RNM-243	Brake arm (R)	
	24	RED-209	Auto clutch felt	79	RNM-244	FR arm gear (B)	
	25	RNM-205	Auto clutch	80	RNM-245	Shift arm (FR)	
C	26	RNM-213	Auto gear	81	RNM-246	P-M lever (A)	
	27	RNM-214	Auto sensor	82	RNM-247	P-M lever (B)	
	28	RNM-215	Auto arm	83	RNM-248	G lock arm (RV)	
	29	RXC-165	Reel (B) assembly	84	RNM-249	P cam gear	
	30	RXC-166	Clutch assembly (B)	85	RNM-250	Gear lock arm (P)	
	31			86	RNM-251	Pause cam	
	32	RXC-176	Auto cam arm assembly	87	RXC-168	RV lever assembly	
	33	RXC-177	FR Idler arm assembly	88	RNM-237	Mode arm	
	34	RBL-189	Tape G spring (L)	89	WA026N070C050	Nylon washer	
	35	RBL-190	Tape G spring (R)	90	RBL-183	E lever spring	
D	36	RBL-191	P Idler spring (B)	91	RNM-198	Eject lever	
	37	RLB-606	Guide roller	92	NB20FMC	Nut	
	38	RBA-099	Screw	93	PMD20P040FMC	Pan screw	
	39	RBL-192	RV arm spring	94	PMD20P050FMC	Pan screw	
	40	RBL-193	H chasis return SP	95	PSD20P030FMC	Tap tite screw	
	41	RBL-194	Lock cam (M) SP	96	PSD20P040FMC	Tap tite screw	
	42	RBL-195	Cam spring	97	PSD20P050FMC	Tap tite screw	
	43	RBL-196	REC lever SP	98	PSD20P080FMC	Tap tite screw	
	44	RBL-197	REC M arm spring	99	PSD20P100FMC	Tap tite screw	
	45	RBL-198	REC stopper SP	100	PSD26P040FMC	Tap tite screw	
46	RBL-199	AS dir arm SP	101	RBA-097	Screw (B)		
47	RBL-200	Auto stop SP	102	RBE-025	Washer (B)		
48	RBL-201	G lock arm (P) SP	103	RBF-076	Polyslider washer		
49	RBL-202	REW stop SP	104	RBF-083	Polyslider washer		
50	RBL-203	FF lever SP	105	REB-556	Motor cushion		
51	RBL-204	FR arm (B) SP	106	WA021D040D050	Polyslider washer		
52	RBL-205	Brake arm SP	107	WA021D040D025	Polyslider washer		
53	RBL-206	Pause lever SP	108	YE20S			
54	RBL-210	Shift arm spring	109	YE25S			
55	RBL-208	P-M lever SP	110	RBL-223	REC sensor SP (L)		

Tape Transporte Unit (Deck I: side)

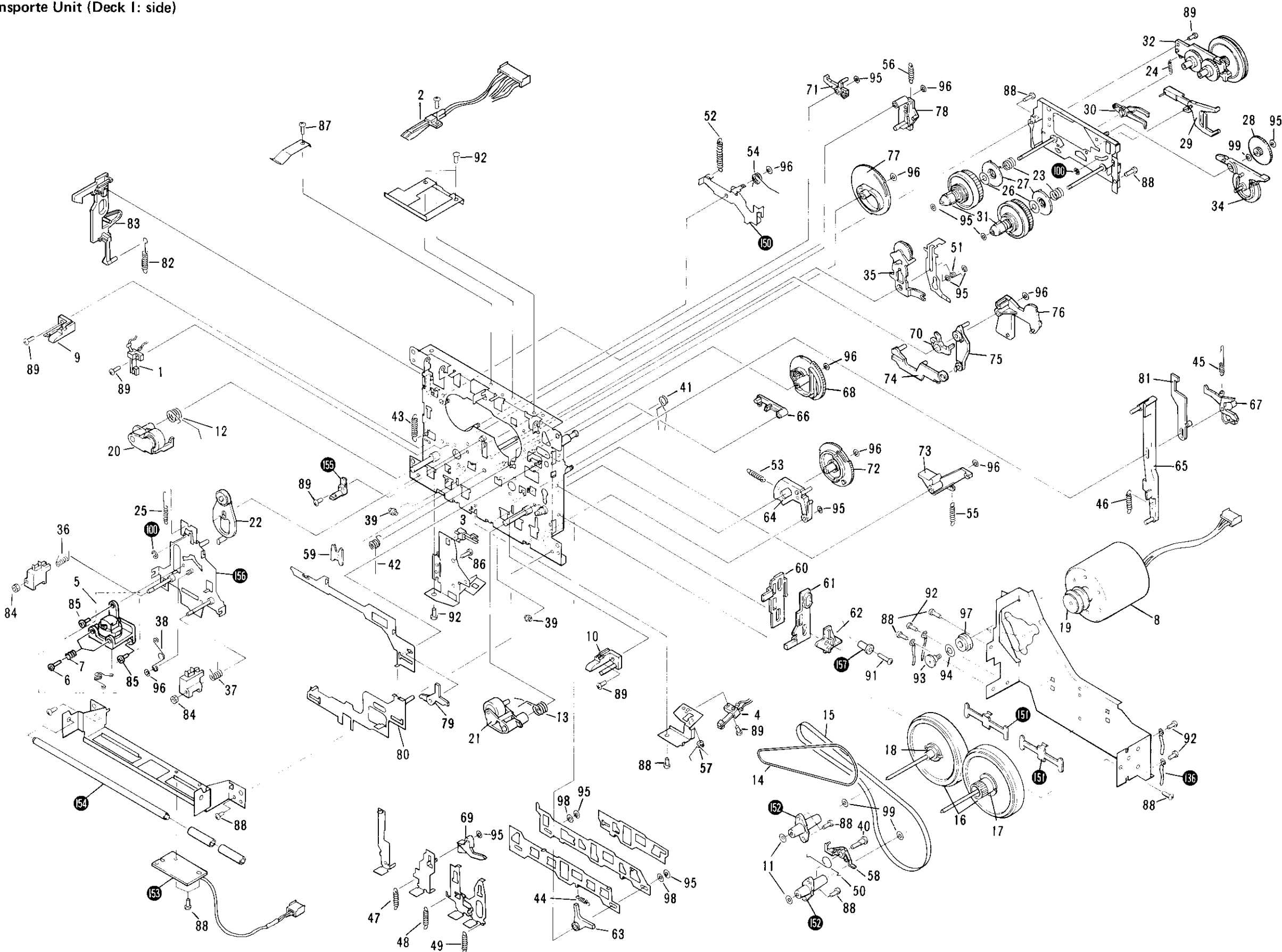

Parts List of

Mark	No.	Pa
	1	RS
	2	RS
	3	RS
	4	RS
	5	RX
	6	RE
	7	RE
	8	RX
	9	RM
	10	RM
	11	RE
	12	RE
	13	RE
	14	RE
	15	RE
	16	RM
	17	RM
	18	RM
	19	RM
	20	RX
	21	RX
	22	RX
	23	RE
	24	RE
	25	RE
	26	RE
	27	RM
	28	RM
	29	RM
	30	RM
	31	RX
	32	RX
	33	
	34	RX
	35	RX
	36	RE
	37	RE
	38	RE
	39	RL
	40	RE
	41	RE
	42	RE
	43	RE
	44	RE
	45	RE
	46	RE
	47	RE
	48	RE
	49	RE
	50	RE
	51	RE
	52	RE
	53	RE
	54	RE
	55	RE

Parts List of Tape Transport Unit (Deck I: side)

Mark	No.	Part No.	Description	Mark	No.	Part No.	Description
A	1	RSN-040	Leaf switch (S1403 REV)	56	RBL-211	G lock arm (P) SP-C	
	2	RSN-041	Leaf switch (S1404 70μSec)	57	RBL-218	Solenoid spring	
	3	RSN-042	Leaf switch (S1401 PLAY)	58	RNM-187	FF arm (B)	
	4	RSN-043	Leaf switch (S1402 FF/REW)	59	RNM-230	Idler arm	
	5	RXC-173	R-head assembly	60	RNM-231	Mode lever	
	6	RBA-098	Azimuth screw	61	RNM-232	Direction lever	
	7	RBL-216	Azimuth spring	62	RNM-233	Direction ST arm	
	8	RXM-145	Motor	63	RNM-234	Cam cancel lever	
	9	RNM-195	Cassette guide (L)	64	RNM-235	G lock arm (FR)	
	10	RNM-196	Cassette guide (R)	65	RNM-236	Auto stop lever	
B	11	RBF-050	Washer	66	RNM-238	AS direction arm	
	12	RBL-184	P roller spring (L)	67	RNM-239	Direction arm	
	13	RBL-185	P roller spring (R)	68	RNM-240	RV cam gear	
	14	REB-551	FR belt (H)	69	RNM-241	Play arm	
	15	REB-552	Drive belt (H)	70	RNM-242	Brake arm (L)	
	16	RNG-361	Flywheel (C)	71	RNM-243	Brake arm (R)	
	17	RNM-199	Flywheel gear	72	RNM-244	FR cam gear (B)	
	18	RNM-200	Flywheel collar	73	RNM-245	Shift arm (FR)	
	19	RNM-203	Motor pulley (H)	74	RNM-246	P-M lever (A)	
	20	RXC-162	P roller arm assembly (L)	75	RNM-247	P-M lever (B)	
C	21	RXC-163	P roller arm assembly (R)	76	RNM-248	G lock arm (RV)	
	22	RXC-175	P idler arm assembly	77	RNM-249	P cam gear	
	23	RBL-186	Back T spring (B)	78	RNM-250	Gear lock arm (P)	
	24	RBL-187	Auto arm spring	79	RNM-252	U mode arm	
	25	RBL-188	Idler spring	80	RXC-168	RV lever assembly	
	26	RED-209	Auto clutch felt	81	RNM-237	Mode arm	
	27	RNM-205	Auto clutch	82	RBL-183	E lever spring	
	28	RNM-213	Auto gear	83	RNM-198	Eject lever	
	29	RNM-214	Auto sensor	84	NB20FMC	Nut	
	30	RNM-215	Auto arm	85	PMD20P040FMC	Pan screw	
D	31	RXC-165	Reel (B) assembly	86	PMD20P050FMC	Pan screw	
	32	RXC-166	Clutch assembly (B)	87	PSD20P030FMC	Tap tite screw	
	33			88	PSD20P040FMC	Tap tite screw	
	34	RXC-176	Auto cam arm assembly	89	PSD20P050FMC	Tap tite screw	
	35	RXC-177	FR idler arm assembly	90	PSD20P080FMC	Tap tite screw	
	36	RBL-189	Tape G spring (L)	91	PSD20P100FMC	Tap tite screw	
	37	RBL-190	Tape G spring (R)	92	PSD26P040FMC	Tap tite screw	
	38	RBL-191	P idler spring (B)	93	RBA-097	Screw (B)	
	39	RLB-606	Guide roller	94	RBE-025	Washer (B)	
	40	RBA-099	Screw	95	RBF-076	Polyslider washer	
	41	RBL-192	RV arm spring	96	RBF-083	Polyslider washer	
	42	RBL-193	H chasis return SP	97	REB-556	Motor cushion	
	43	RBL-194	Lock cam (M) SP	98	WA021D040D050	Polyslider washer	
	44	RBL-195	Cam spring	99	WA021D040D025	Polyslider washer	
	45	RBL-199	AS dir arm SP	100	YE205		
	46	RBL-200	Auto stop SP	150		Shift arm assembly	
	47	RBL-201	G lock arm (P) SP	151		Capstan spacer	
	48	RBL-202	REW lever SP	152		Housing assembly	
	49	RBL-203	FF lever SP	153		Head P.C.B.	
	50	RBL-204	FR arm (B) SP	154		Button shaft	
	51	RBL-205	Brake arm SP	155		Guide pole	
	52	RBL-210	Shift arm spring	156		Head chassis assembly	
	53	RBL-208	P-M lever SP	157		Color	
	54	RBL-209	Shift arm SP				
	55	RBL-210	Shift arm R-SP (B)				

6. PACKING

Parts List

Mark	No.	Part No.	Description
	1	RHA1001	Pad (UPPER)
	2	RHA1002	Pad (LOWER)
	3	RRB-276	Operating instructions (English)
	4	RHC-161	Styrene paper
	5	RHG-887	Packing case
	50		Connection cord assembly

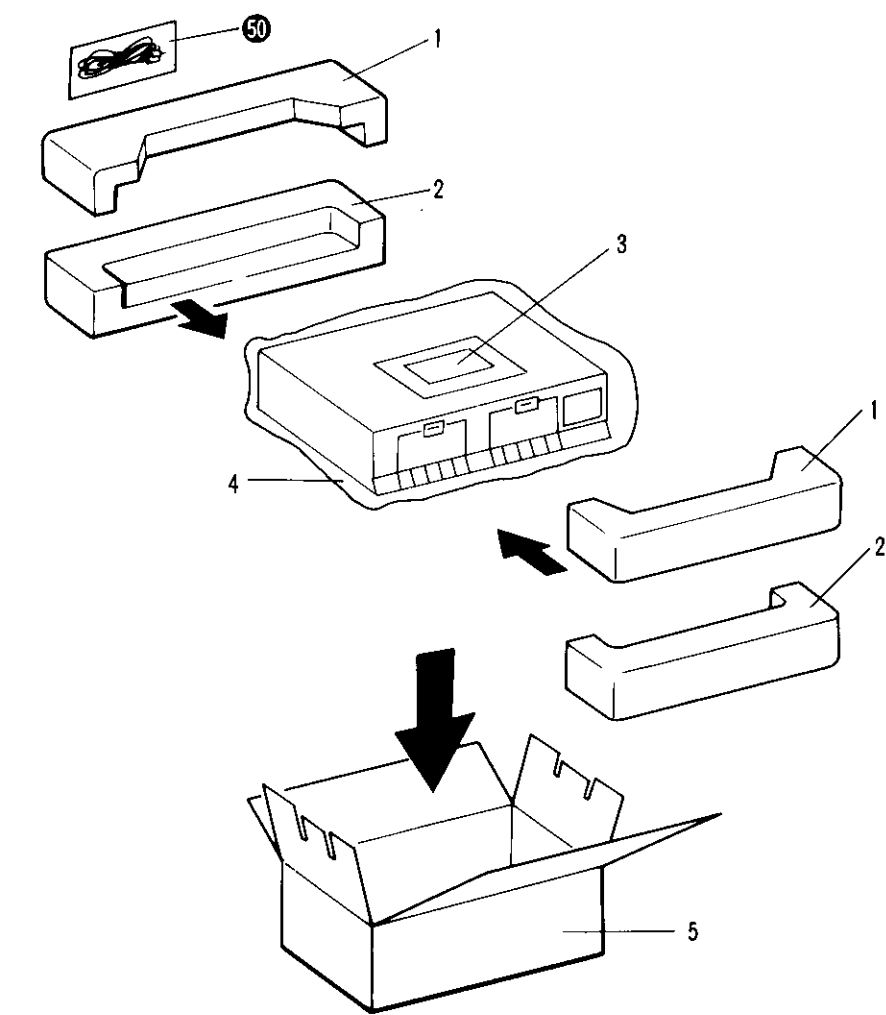

Q320 Q310 Q319 Q313 Q318 Q315 Q317
Q323 Q321 Q307 Q305 Q306 Q316 Q312
Q301 Q311

SUB UNIT

VR306 VR307
VR305 VR304

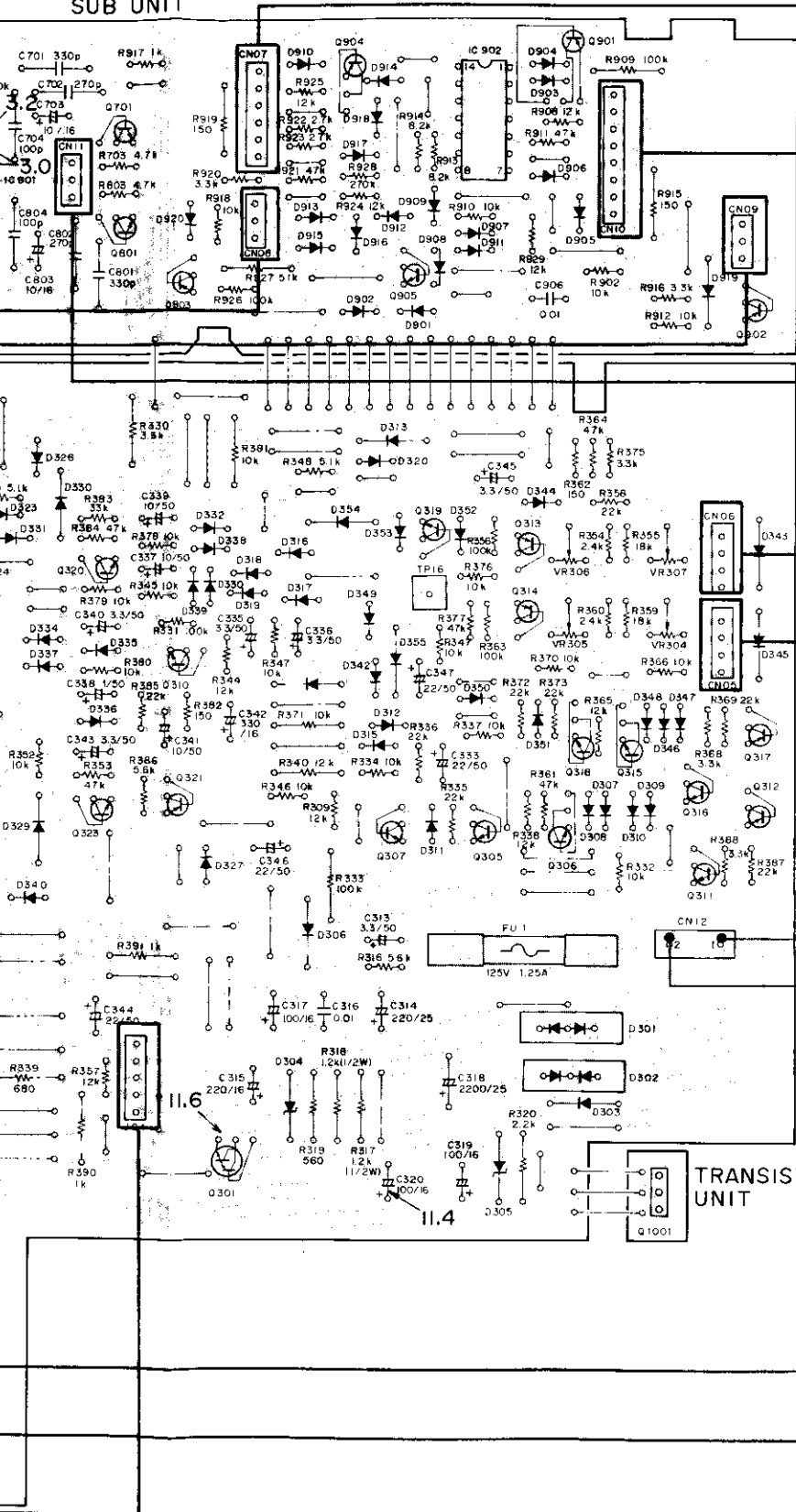

IC901 M5220L
IC902 TC4011BP
Q701-703, 801-803 2SC1740SLN
Q901-904 2SA933S
Q905 DTC114ES
D901-920 1SS254

IC301, 303, 304 M5218L
IC302 HA1208BNT
Q101, 201 2SC2240
Q102-110, 202-210, 305-307, 309, 310, 315 2SC1740SLN
Q301 2SD1276
Q302, 303 2SC3246
Q304 2SD1302
Q308, 313, 314, 321, 324 2SA933S
Q311, 316 DTC114S
Q312, 317 2SA934

D301 1B2Z1-LC2
D302 1B2S1-LC2
D303, 343, 345 1SR35-100A
D304, 305 MTZ13A
D306-342, 344, 346-455 1SS254

TRANSISTOR UNIT

POWER SW UNIT

MECHANISM I UNIT (1/2)

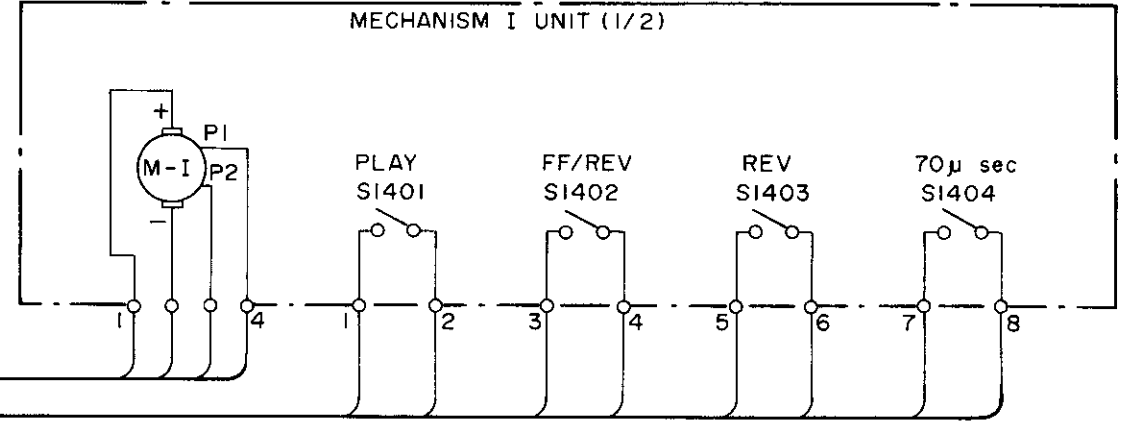

MECHANISM II UNIT (1/3)

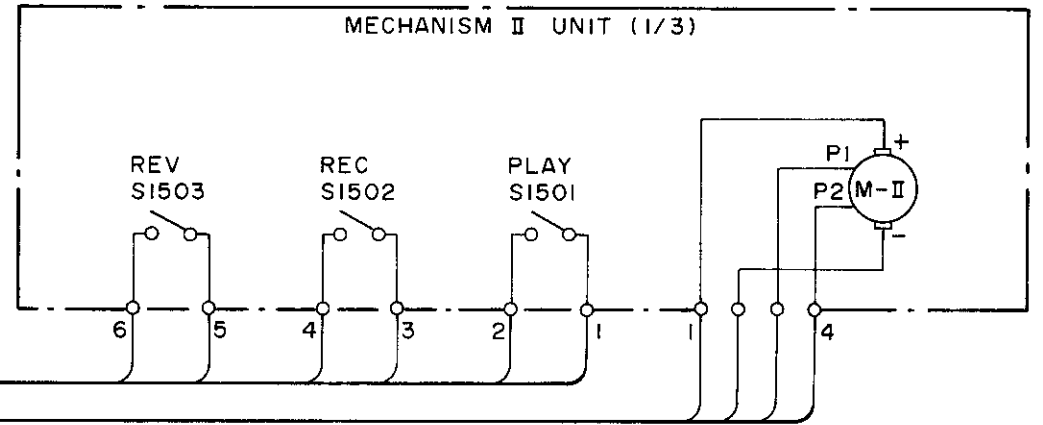

MECHANISM I UNIT (2/2)

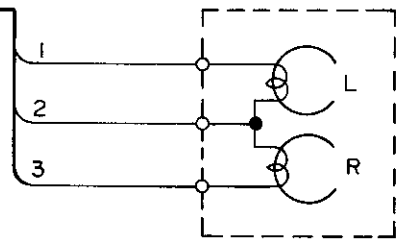

MECHANISM II UNIT (2/3)

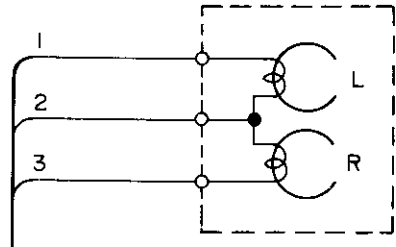

MECHANISM II UNIT (3/3)

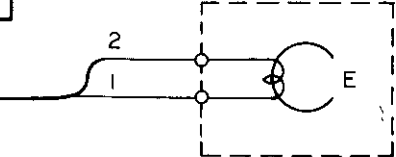

A

B

C

D

9. SCHEMATIC DIAGRAM

A

B

C

D

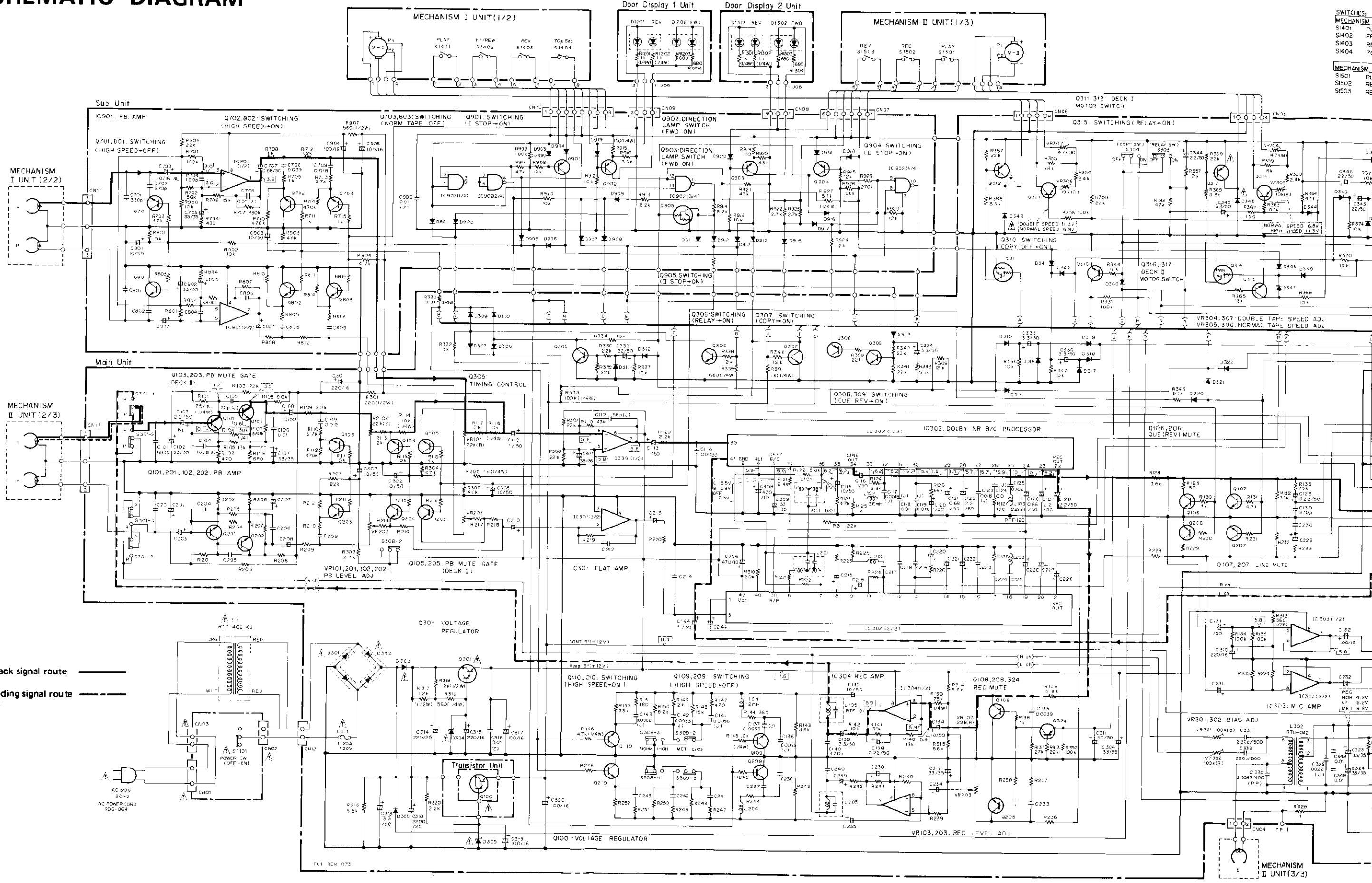

SWITCHES:
 S1401 PL.
 S1402 FF.
 S1403 RE.
 S1404 TO.

MECHANISM 1:
 S1501 PL.
 S1502 RE.
 S1503 REV.

1

2

3

4

5

6

MECHANISM II UNIT (3/3)

FU1 REK 073

Playback signal route (Lch)
 Recording signal route (Rch)

AC 120V 60Hz
 AC POWER CORD RDG-064

VR101, 201, 102, 202: PB LEVEL ADJ.

VR103, 203: REC. LEVEL ADJ.

VR301, 302: BIAS ADJ.

VR303, 306: DOUBLE TAPE SPEED ADJ.

VR305, 306: NORMAL TAPE SPEED ADJ.

VR307, 308: DOUBLE TAPE SPEED ADJ.

VR309, 310: NORMAL TAPE SPEED ADJ.

VR311, 312: DECK I MOTOR SWITCH.

VR313, 314: DECK II MOTOR SWITCH.

VR315, 316: DECK I MOTOR SWITCH.

VR317, 318: DECK II MOTOR SWITCH.

VR319, 320: DECK I MOTOR SWITCH.

VR321, 322: DECK II MOTOR SWITCH.

VR323, 324: DECK I MOTOR SWITCH.

VR325, 326: DECK II MOTOR SWITCH.

VR327, 328: DECK I MOTOR SWITCH.

VR329, 330: DECK II MOTOR SWITCH.

VR331, 332: DECK I MOTOR SWITCH.

VR333, 334: DECK II MOTOR SWITCH.

VR335, 336: DECK I MOTOR SWITCH.

VR337, 338: DECK II MOTOR SWITCH.

VR339, 340: DECK I MOTOR SWITCH.

VR341, 342: DECK II MOTOR SWITCH.

VR343, 344: DECK I MOTOR SWITCH.

VR345, 346: DECK II MOTOR SWITCH.

VR347, 348: DECK I MOTOR SWITCH.

VR349, 350: DECK II MOTOR SWITCH.

VR351, 352: DECK I MOTOR SWITCH.

VR353, 354: DECK II MOTOR SWITCH.

VR355, 356: DECK I MOTOR SWITCH.

VR357, 358: DECK II MOTOR SWITCH.

VR359, 360: DECK I MOTOR SWITCH.

VR361, 362: DECK II MOTOR SWITCH.

VR363, 364: DECK I MOTOR SWITCH.

VR365, 366: DECK II MOTOR SWITCH.

VR367, 368: DECK I MOTOR SWITCH.

VR369, 370: DECK II MOTOR SWITCH.

VR371, 372: DECK I MOTOR SWITCH.

VR373, 374: DECK II MOTOR SWITCH.

VR375, 376: DECK I MOTOR SWITCH.

VR377, 378: DECK II MOTOR SWITCH.

VR379, 380: DECK I MOTOR SWITCH.

VR381, 382: DECK II MOTOR SWITCH.

VR383, 384: DECK I MOTOR SWITCH.

VR385, 386: DECK II MOTOR SWITCH.

VR387, 388: DECK I MOTOR SWITCH.

VR389, 390: DECK II MOTOR SWITCH.

VR391, 392: DECK I MOTOR SWITCH.

VR393, 394: DECK II MOTOR SWITCH.

VR395, 396: DECK I MOTOR SWITCH.

VR397, 398: DECK II MOTOR SWITCH.

VR399, 400: DECK I MOTOR SWITCH.

- SWITCHES:**
- MECHANISM 1 UNIT**
- S1401 PLAY
 - S1402 FF/REW
 - S1403 REV
 - S1404 70usec
- MECHANISM 2 UNIT**
- S1501 PLAY
 - S1502 REC
 - S1503 REV
- MAIN UNIT**
- S301 REC-PB
 - S302 REC MUTE
 - S303 RELAY
 - S304 COPY
 - S305 SPEED
 - S306 DOLBY
 - S307 NR TYPE
 - S308 TAPE POSITION HIGH-NORM
 - S309 TAPE POSITION METAL-CrO2
- POWER SW UNIT**
- S101 POWER ON-OFF

NOTE:
The indicated semiconductors are representative ones only. Other alternative semiconductors may be used and are listed in the parts list.

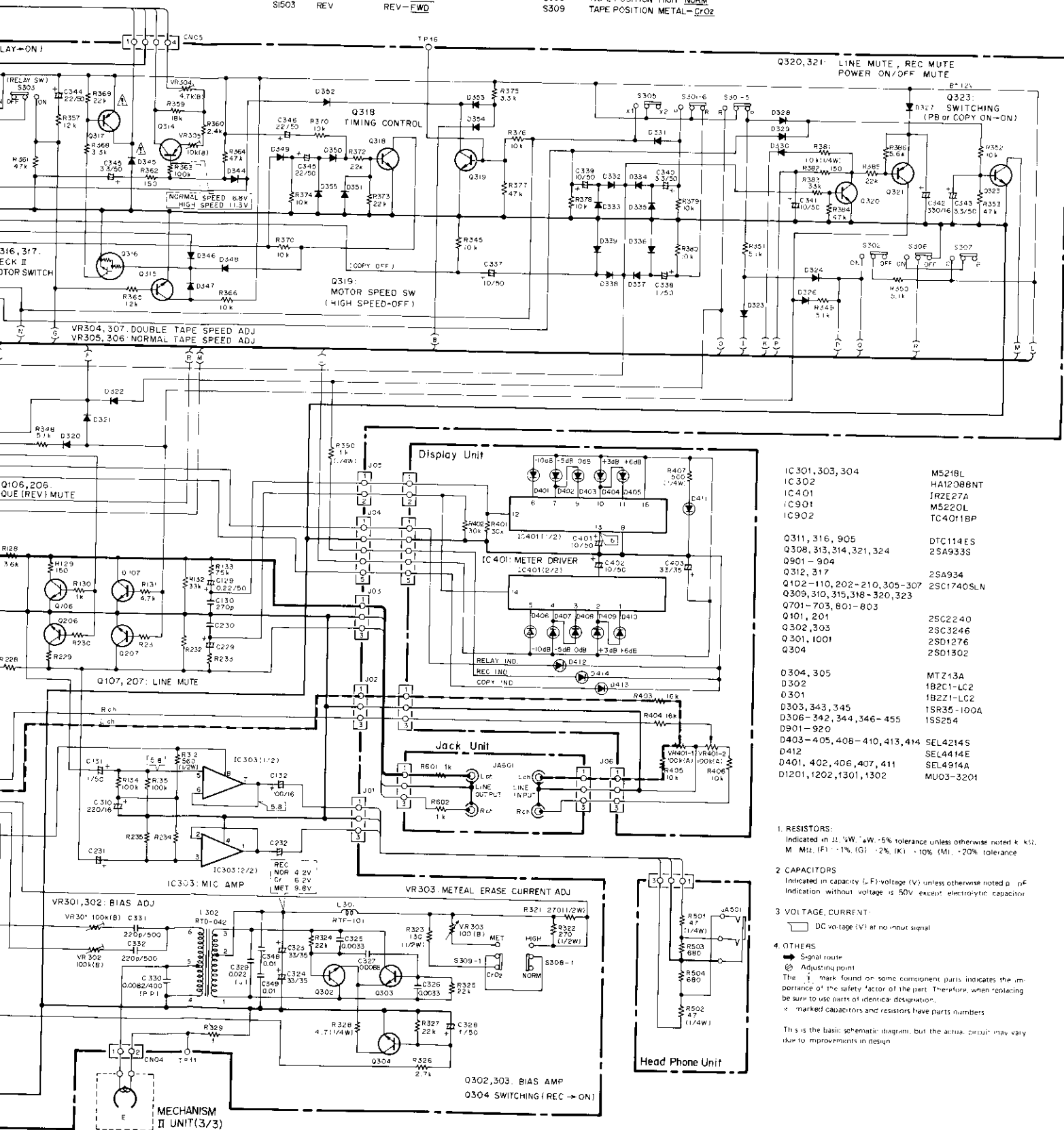

External Appearance of Transistors and ICs

<p>M5218L M5220L</p> <p>HA12088NT</p> <p>DTC114ES</p> <p>2SA933S</p> <p>2SC1740SLN</p> <p>IR2E27A</p>	<p>2SA934</p> <p>2SC2240</p> <p>2SC3246</p> <p>2SD1302</p> <p>TC4011BP</p> <p>2SD1302</p> <p>2SD1276</p>	<p>A</p> <hr/> <p>B</p> <hr/> <p>C</p> <hr/> <p>D</p>
--	---	---

10. ELECTRICAL PARTS LIST

- NOTES:**
- When ordering resistors, first convert resistance values into code form as shown in the following examples.
 - Ex. 1** When there are 2 effective digits (any digit apart from 0), such as 560 ohm and 47k ohm (tolerance is shown by J=5%, and K=10%).

560Ω	56 × 10 ¹	561	RD½PS	5	6	1	J
47kΩ	47 × 10 ³	473	RD½PS	4	7	3	J
0.5Ω	0R5		RN2H	0	R	5	K
1Ω	010		RS1P	0	1	0	K
 - Ex. 2** When there are 3 effective digits (such as in high precision metal film resistors).

5.62kΩ	562 × 10 ¹	5621	RN½SR	5	6	2	1	F
--------	-----------------------	------	-------	---	---	---	---	---
 - The **△** mark found on some component parts indicates the importance of the safety factor of the part. Therefore, when replacing, be sure to use parts of identical designation.
 - For your Parts Stock Control, the fast moving items are indicated with the marks **★★** and **★**. **★★ GENERALLY MOVES FASTER THAN ★**
 - This classification shall be adjusted by each distributor because it depends on model number, temperature, humidity, etc.
 - Parts marked by " **⊙** " are not always kept in stock. Their delivery time may be longer than usual or they may be unavailable.

Miscellaneous Parts

P.C. BOARD UNITS

Mark	Symbol & Description	Part No.
	Power switch unit	Non supply
	Main unit	Non supply
	Display unit	Non supply
	Door display 1 unit	Non supply
	Door display 2 unit	Non supply
	Transistor unit	Non supply
	Headphone unit	Non supply
	Sub unit	Non supply
	Jack unit	Non supply

OTHERS

Mark	Symbol & Description	Part No.
△	AC power cord	RDG-064
△	FU1 Fuse 1.25A (20mm) 120V	REK-073
△ ★	T1 Power transformer (120V)	RTT-462

Power Switch Unit

SWITCH

Mark	Symbol & Description	Part No.
△★★	S1101 (Power switch)	RSA-068

Main Unit

SEMICONDUCTORS

Mark	Symbol & Description	Part No.
★★	IC301, IC303, IC304	M5218L
★★	IC302	HA12088NT
★★	Q311, Q316	DTC114ES
★★	Q308, Q313, Q314, Q321, Q324	2SA933S
△★★	Q312, Q317	2SA934
★★	Q102-Q110, Q202-Q210, Q305-Q307, Q309, Q310, Q315, Q318-Q320, Q323	2SC1740SLN
★★	Q101, Q201	2SC2240
★★	Q302, Q303	2SC3246
△★★	Q301	2SD1276
★★	Q304	2SD1302
△★★	D304, D305	MTZ13A
△★	D302	1B2C1-LC2
△★	D301	1B2Z1-LC2
△★	D303, D343, D345	1SR35-100A
★	D306-D324, D326-D342, D344, D346-D355	1SS254

SWITCHES

Mark	Symbol & Description	Part No.
★★	S308, S309 Push switch (TAPE POSITION)	RSG-166
★★	S302-S307 Push switch	RSG-186
★★	S301 Slide switch (REC-PB)	RSH-080

COILS, FILTER

Mark	Symbol & Description	Part No.
	L302 Oscillator coil	RTD-042
	L301 Line coil	RTF-101
	L103, L303 Peaking coil	RTF-120
	L104, L204 Peaking coil	RTF-129
	L102, L202 Coil (36MH)	RTF-155
	L105, L205 Trap coil	RTF-157
	F101, F201 MPX filter	RTF-165

CAPACITORS

Mark	Symbol & Description	Part No.
	C331, C332	CCDSL221K500
	C104, C204	CCPSL101J50
	C105, C205	CCPSL220J50
	C112, C212	CCPSL560J50
	C103, C203	CEANL2R2M50
	C129, C138, C229, C238	CEAR22M50
	C121, C126, C221, C226	CEAR68M50
	C110, C113, C116, C120, C131, C144, C210, C213, C216, C220, C231, C244, C328, C338	CEAS010M50
	C108, C115, C134, C135, C208, C215, C234, C235, C302, C303, C305, C337, C339, C341, C311	CEAS100M50
	C132, C232, C317, C319, C320	CEAS101M16

C122, C127, C128, C222, C227, C228	CEAS2R2M50
C333, C344, C346, C347	CEAS220M50
C301, C310, C315	CEAS221M16
C314	CEAS221M25
C318	CEAS222M25
C139, C239, C313, C334-C336, C340, C343, C345	CEAS3R3M50
C102, C107, C202, C207, C304, C307, C309, C312, C323, C324	CEAS330M50
C342	CEAS331M16
C308	CEAS471M10
C306	CEAS471M16

C348, C316, C349	CKDYF103Z50
C130, C230	CKPYB271K50
C140, C240	CKPYB471K50
C101, C201	CKPYB681K50
C106, C118, C124, C206, C218, C224	CQMA103J50
C109, C209	CQMA153K50
C117, C217	CQMA182J50
C119, C123, C219, C223	CQMA183J50
C114, C143, C214, C243	CQMA222K50
C136, C137, C236, C237, C325, C326, C142, C242	CQMA332J50

C329	CQMA223J50
C133, C233	CQMA392J50
C141, C241	CQMA562J50
C327	CQMA682K50
C125, C225	CQMA823K50
C330	CQPA822J400

RESISTORS

Note: When ordering resistors, convert the resistance value into code form, and then rewrite the part no. as before.

Mark	Symbol & Description	Part No.
★	VR305-VR306	VRTB6VS103
★	VR301, VR302	VRTB6VS104
★	VR101-VR103, VR201-VR203	VRTB6VS223
★	VR303	RCP-031
	VR304, VR307	VRTB6VS472
	R301, R312, R317, R318, R321-R323	RD1/2PMF□□□J
	R101, R104, R114, R118, R139, R145, R146, R201, R204, R214, R218, R239, R245, R246, R305, R319, R320, R328, R330, R333, R340, R339, R371, R381, R390, R391	RD1/4PM□□□J
	Other resistors	RD1/6PM□□□J

OTHERS

Mark	Symbol & Description	Part No.
	Fuse holder	RKR-025

Sub Unit

SEMICONDUCTORS

Mark	Symbol & Description	Part No.
★★	IC901	M5220L
★★	IC902	TC4011BP
★★	Q905	DTC114ES
★★	Q901-Q904	2SA933S
★★	Q701-Q703, Q801-Q803	2SC1740SLN
★	D901-D920	1SS254

CAPACITORS

Mark	Symbol & Description	Part No.
	C704, C804	CCPSL101J50
	C703, C803	CEANL100M16
	C707, C807	CEAR68M50
	C901, C903	CEAS100M50
	C904, C905	CEAS101M16
	C705, C805, C902	CEAS330M35
	C906	CKDYF103Z50
	C702, C802	CKPYB271K50
	C701, C801	CKPYB331K50
	C706, C806	CQMA103J50
	C709, C809	CQMA183J50
	C708, C808	CQMA393J50

RESISTORS

Note: When ordering resistors, convert the resistance value into code form, and then rewrite the part no. as before.

Mark	Symbol & Description
	R927, R909, R915
	R907
	Other resistors

Jack Unit

RESISTORS

Mark	Symbol & Description
	R601, R602

OTHERS

Mark	Symbol & Description
	JA601 Pin jack (L)

Display Unit

SEMICONDUCTORS

Mark	Symbol & Description
★★	IC401
★	D403-D405, D407
★	D414
★	D412
★	D401, D402, D404

CAPACITORS

Mark	Symbol & Description
	C401, C402
	C403

RESISTORS

Note: When ordering resistors, convert the resistance value into code form, and then rewrite the part no. as before.

Mark	Symbol & Description
	VR401 Slide volu
	R407
	Other resistors

Door Display 1 Unit

SEMICONDUCTORS

Mark	Symbol & Description
★	D1201, D1202 L

COILS, FILTER

Mark	Symbol & Description	Part No.
L302	Oscillator coil	RTD-042
L301	Line coil	RTF-101
L103, L303	Peaking coil	RTF-120
L104, L204	Peaking coil	RTF-129
L102, L202	Coil (36MH)	RTF-155
L105, L205	Trap coil	RTF-157
F101, F201	MPX filter	RTF-165

CAPACITORS

Mark	Symbol & Description	Part No.
C331, C332		CCDSL221K500
C104, C204		CCPSL101J50
C105, C205		CCPSL220J50
C112, C212		CCPSL560J50
C103, C203		CEANL2R2M50
C129, C138, C229, C238		CEAR22M50
C121, C126, C221, C226		CEAR68M50
C110, C113, C116, C120, C131, C144, C210, C213, C216, C220, C231, C244, C328, C338		CEAS010M50
C108, C115, C134, C135, C208, C215, C234, C235, C302, C303, C305, C337, C339, C341, C311		CEAS100M50
C132, C232, C317, C319, C320		CEAS101M16
C122, C127, C128, C222, C227, C228		CEAS2R2M50
C333, C344, C346, C347		CEAS220M50
C301, C310, C315		CEAS221M16
C314		CEAS221M25
C318		CEAS222M25
C139, C239, C313, C334—C336, C340, C343, C345		CEAS3R3M50
C102, C107, C202, C207, C304, C307, C309, C312, C323, C324		CEAS330M50
C342		CEAS331M16
C308		CEAS471M10
C306		CEAS471M16
C348, C316, C349		CKDYF103Z50
C130, C230		CKPYB271K50
C140, C240		CKPYB471K50
C101, C201		CKPYB681K50
C106, C118, C124, C206, C218, C224		CQMA103J50
C109, C209		CQMA153K50
C117, C217		CQMA182J50
C119, C123, C219, C223		CQMA183J50
C114, C143, C214, C243		CQMA222K50
C136, C137, C236, C237, C325, C326, C142, C242		CQMA332J50
C329		CQMA223J50
C133, C233		CQMA392J50
C141, C241		CQMA562J50
C327		CQMA682K50
C125, C225		CQMA823K50
C330		CQPA822J400

RESISTORS

Note: When ordering resistors, convert the resistance value into code form, and then rewrite the part no. as before.

Mark	Symbol & Description	Part No.
★	VR305—VR306	VRTB6VS103
★	VR301, VR302	VRTB6VS104
★	VR101—VR103, VR201—VR203	VRTB6VS223
★	VR303	RCP-031
	VR304, VR307	VRTB6VS472
	R301, R312, R317, R318, R321—R323	RD1/2PMF□□□J
	R101, R104, R114, R118, R139, R145, R146, R201, R204, R214, R218, R239, R245, R246, R305, R319, R320, R328, R330, R333, R340, R339, R371, R381, R390, R391	RD1/4PM□□□J
	Other resistors	RD1/6PM□□□J

OTHERS

Mark	Symbol & Description	Part No.
	Fuse holder	RKR-025

Sub Unit

SEMICONDUCTORS

Mark	Symbol & Description	Part No.
★★	IC901	M5220L
★★	IC902	TC4011BP
★★	Q905	DTC114ES
★★	Q901—Q904	2SA933S
★★	Q701—Q703, Q801—Q803	2SC1740SLN
★	D901—D920	1SS254

CAPACITORS

Mark	Symbol & Description	Part No.
	C704, C804	CCPSL101J50
	C703, C803	CEANL100M16
	C707, C807	CEAR68M50
	C901, C903	CEAS100M50
	C904, C905	CEAS101M16
	C705, C805, C902	CEAS330M35
	C906	CKDYF103Z50
	C702, C802	CKPYB271K50
	C701, C801	CKPYB331K50
	C706, C806	CQMA103J50
	C709, C809	CQMA183J50
	C708, C808	CQMA393J50

RESISTORS

Note: When ordering resistors, convert the resistance value into code form, and then rewrite the part no. as before.

Mark	Symbol & Description	Part No.
	R927, R909, R915, R919	RD1/4PM□□□J
	R907	RD1/2PMF□□□J
	Other resistors	RD1/6PM□□□J

Jack Unit

RESISTORS

Mark	Symbol & Description	Part No.
	R601, R602	RD1/4PM102J

OTHERS

Mark	Symbol & Description	Part No.
	JA601 Pin jack (4P)	RKB-020

Display Unit

SEMICONDUCTORS

Mark	Symbol & Description	Part No.
★★	IC401	IR2E27A
★	D403—D405, D408—D410, D413, D414	SEL4214S
★	D412	SEL4414E
★	D401, D402, D406, D407, D411	SEL4914A X/Y

CAPACITORS

Mark	Symbol & Description	Part No.
	C401, C402	CEAS100M50
	C403	CEAS330M35

RESISTORS

Note: When ordering resistors, convert the resistance value into code form, and then rewrite the part no. as before.

Mark	Symbol & Description	Part No.
	VR401 Slide volume	RCW-013
	R407	RD1/4PM561J
	Other resistors	RD1/6PM□□□J

Door Display 1 Unit

SEMICONDUCTORS

Mark	Symbol & Description	Part No.
★	D1201, D1202 LED	MU03-3201

RESISTOR

Note: When ordering resistors, convert the resistance value into code form, and then rewrite the part no. as before.

Mark	Symbol & Description	Part No.
	R1201, R1202	RD1/4PM102J
	R1203, R1204	RD1/6PM681J

Door Display 2 Unit

SEMICONDUCTORS

Mark	Symbol & Description	Part No.
★	D1301, D1302 LED	MU03-3201

RESISTOR

Note: When ordering resistors, convert the resistance value into code form, and then rewrite the part no. as before.

Mark	Symbol & Description	Part No.
	R1301, R1302	RD1/4PM102J
	R1303, R1304	RD1/8PM681J

Transistor Unit

SEMICONDUCTOR

Mark	Symbol & Description	Part No.
▲★★	Q1001	2SD1276

Head Phone Unit

RESISTOR

Note: When ordering resistors, convert the resistance value into code form, and then rewrite the part no. as before.

Mark	Symbol & Description	Part No.
	R501, R502	RD1/4PM470J
	R503, R504	RD1/6PM681J

OTHERS

Mark	Symbol & Description	Part No.
	JA501 Headphone jack	RKN-096

11. ADJUSTMENTS

11-1. MECHANICAL ADJUSTMENT

Door Damping Check and Adjustment

Set the door spring of DECK 1 side to position (B) as shown in Fig. 11-2. Then, erect the front panel A Assembly vertically as shown in Fig. 11-1. Open the doors of DECK 1 and DECK 2 at the same time. At this point, confirm that the difference between opening degree of both doors is within 17mm when one side of the door is opened completely. When this standard is not satisfied, change the door spring installation position of Deck 1 and perform the adjustment as follows:

- When the opening action of the door of DECK 1 is later than that of DECK 2: Change (B) in Fig. 11-2 to that in (A).
- When the opening action of the door of DECK 1 is faster than that of DECK 2: Change (B) in Fig. 11-2 to that in (C).

Tape Speed Adjustment

1. Load the STD-301 test tape into DECKS 1 and 2.
2. Short circuit the TP.16 (×2 ADJ) and GND, and then Put DECK 1 into (double-speed) PLAY state, and adjust with VR307 so that the frequency $6000\text{Hz} \pm 10\text{Hz}$.
3. Stop the DECK 1 operation and put DECK 2 into (double-speed) PLAY state, and adjust with VR304 so that the frequency becomes $\pm 10\text{Hz}$ against that of DECK 1.
4. After releasing the short circuit mentioned in step 2, put DECK 1 into normal speed PLAY state, and adjust with VR306 so that the frequency of it becomes $3000\text{Hz} \pm 5\text{Hz}$.
5. Stop the DECK 1 operation and put DECK 2 into normal speed PLAY state, and adjust with VR305 so that the frequency becomes $\pm 5\text{Hz}$ against DECK 1.

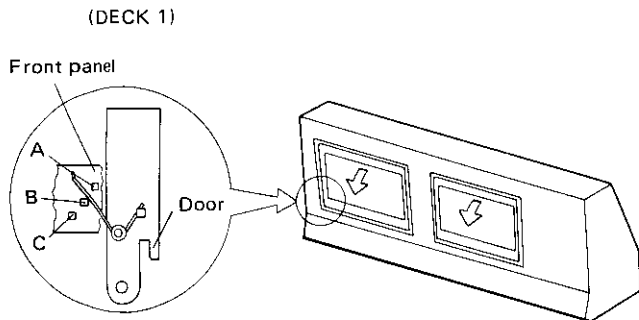

Fig. 11-2

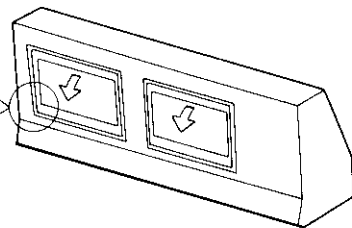

Fig. 11-1

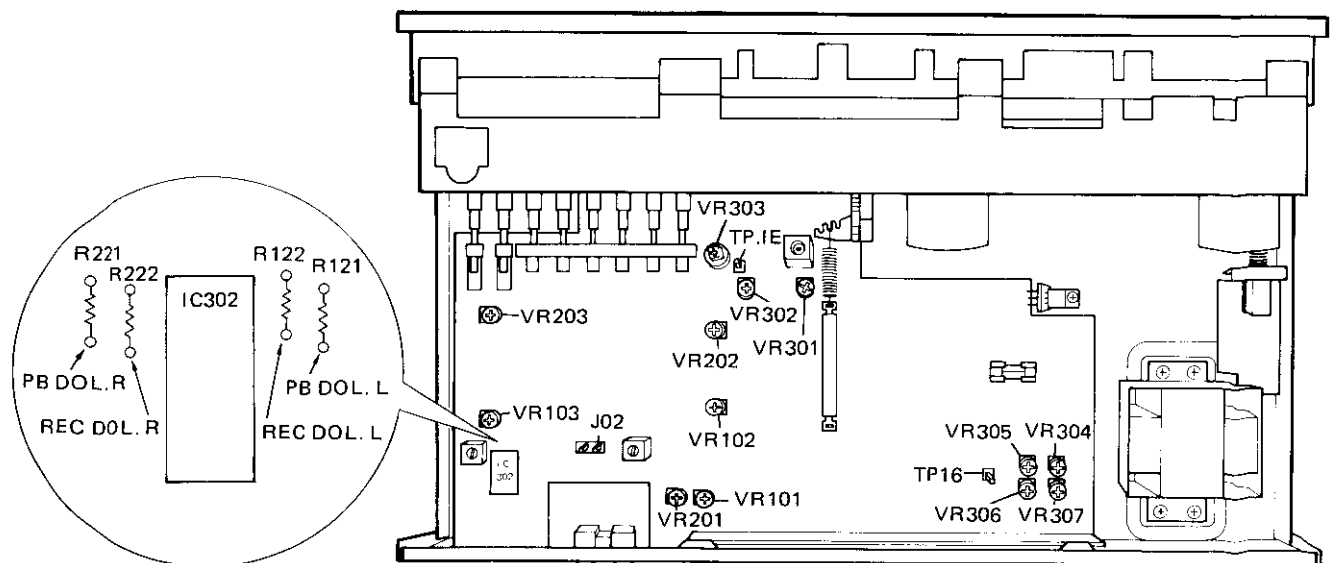

Fig. 11-3 Adjustment location

**Recording/Playback sliding SW stroke adjustment
(Confirmation of noise generation when
REC → STOP)**

While loading the STD-605A onto DECK 2, confirm whether it generates noise or not when it is put into STOP state from REC state.

In the event noise is generated, replace the SW connection spring by applying it as shown in Fig. 11-4. (Be sure that the slide SW is fully pulled when in the REC state, and it has returned completely when in the STOP state.)

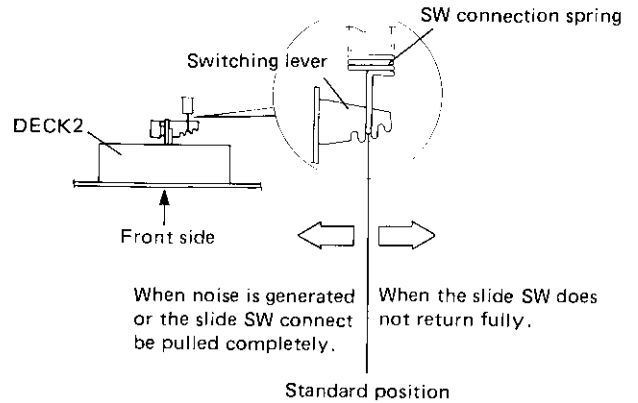

Fig. 11-4 Recording/Playback sliding SW stroke adjustment
(Confirmation of noise generation when REC → STOP)

11.2 ELECTRICAL ADJUSTMENTS

Adjustment Conditions

1. The mechanical adjustments must be completed first.
2. The head must be cleaned and demagnetized.
3. Allow the deck to age for at least a few minutes before commencing any electrical adjustments.
4. The reference signals is 0dBv=1Vrms.
5. Connect a 50 kilo-ohm (or between 47 to 52 kilo-ohm) load resistance to the OUTPUT terminals.
6. Unless otherwise specified, the switches listed below are left in the positions indicated.

DOLBY NR : OFF
TAPE SELECTOR : NORM

Test Tapes

- STD-331B : Playback adjustments
(See Fig. 11-5)
STD-608A : NORMAL blank tape
STD-620 : CrO₂ blank tape
STD-610 : METAL blank tape

List of Adjustments

Deck I

1. Head azimuth adjustment.
2. Playback frequency response check.
3. Playback level adjustment.
4. Playback time constant switching check.

Deck II

1. Head azimuth adjustment.
2. Playback frequency response check.
3. Playback level adjustment.
4. Playback time constant switching check.
5. Erasure current adjustment
6. Recording bias adjustment.
7. Recording level adjustment.
8. Recording and playback frequency response check.
9. Copy mode frequency response check.
10. Level meter check.

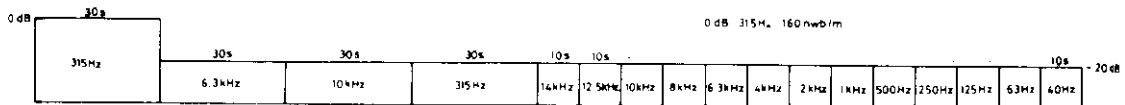

Fig. 11-5 Contents of the test tape STD-331B

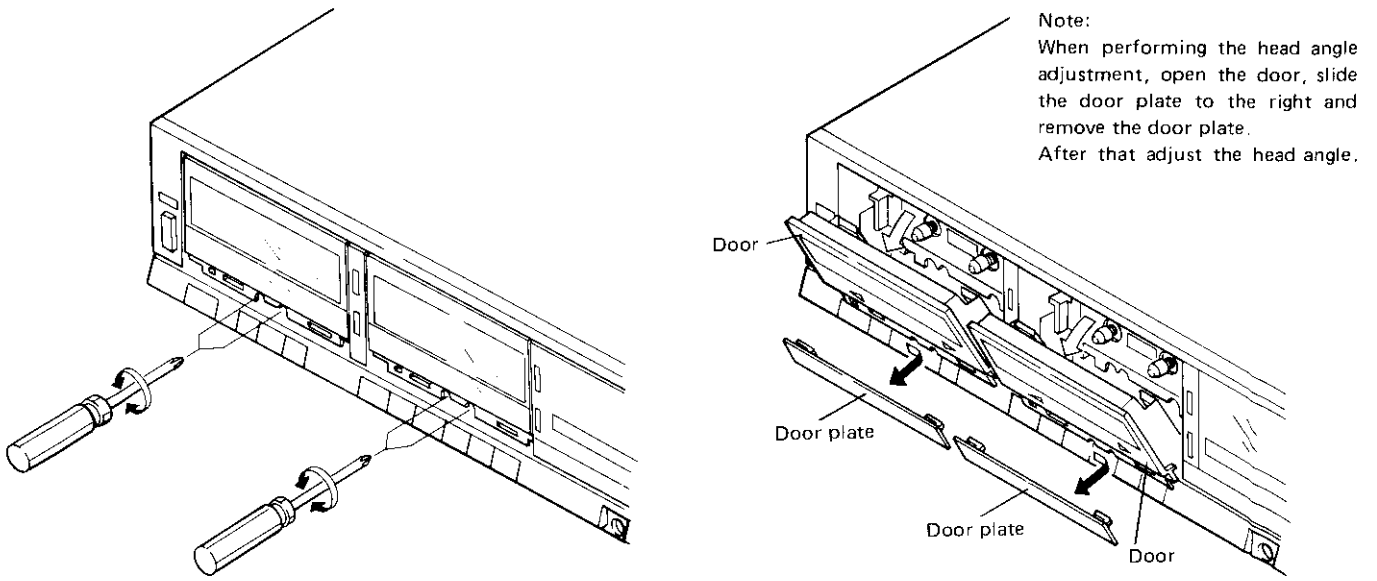

Fig. 11-6 Head azimuth adjustment

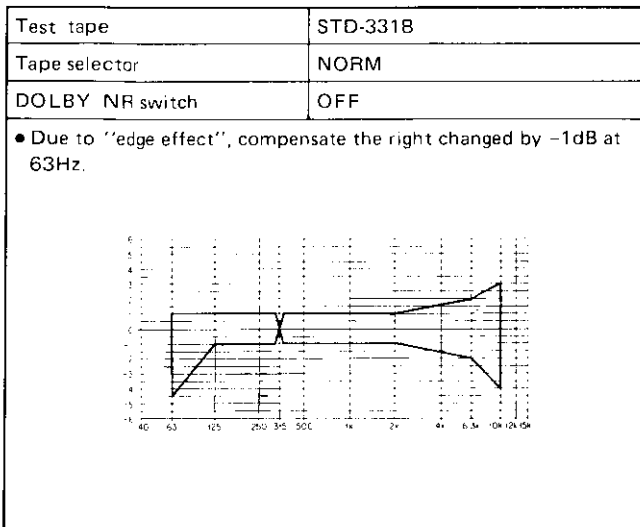

Fig. 11-7 Allowable playback frequency response zone

Deck I

1. Head Azimuth Adjustment						
• Turn VR102 and VR202 to mechanical center positions.						
No.	Mode	Input signal & test tape	Adjustment location	Measuring location	Adjustment value	Remarks
1	PLAY	Play the 10kHz/-20dB section of the STD-331B test tape.	Head azimuth adjustment screw. (FWD, REV) (See Fig. 11-6)	LINE OUT	Maximum playback signal level.	
2	STOP	Lock the screw with screw lock after completing the adjustment.				
2. Playback Frequency Response Check						
No.	Mode	Input signal & test tape	Adjustment location	Measuring location	Adjustment value	Remarks
1	PLAY	STD-331B	—	LINE OUT	The allowable zone shown in Fig. 11-7 is to be satisfied.	
3. Playback Level Adjustment						
• This adjustment determines the DOLBY NR level, and must be performed with great care.						
No.	Mode	Input signal & test tape	Adjustment location	Measuring location	Adjustment value	Remarks
1	PLAY	Play the 315Hz/0dB section of the STD-331B test tape.	VR101 (Lch) VR201 (Rch)	PB DOL, L (Lch) PB DOL, R (Rch)	-13.5dBv	
4. Playback Time Constant Switching Check						
• Put the deck into playback mode with no cassette loaded.						
• Check that the noise level changes at the line playback output terminals when the TAPE SELECTOR switch is changed.						

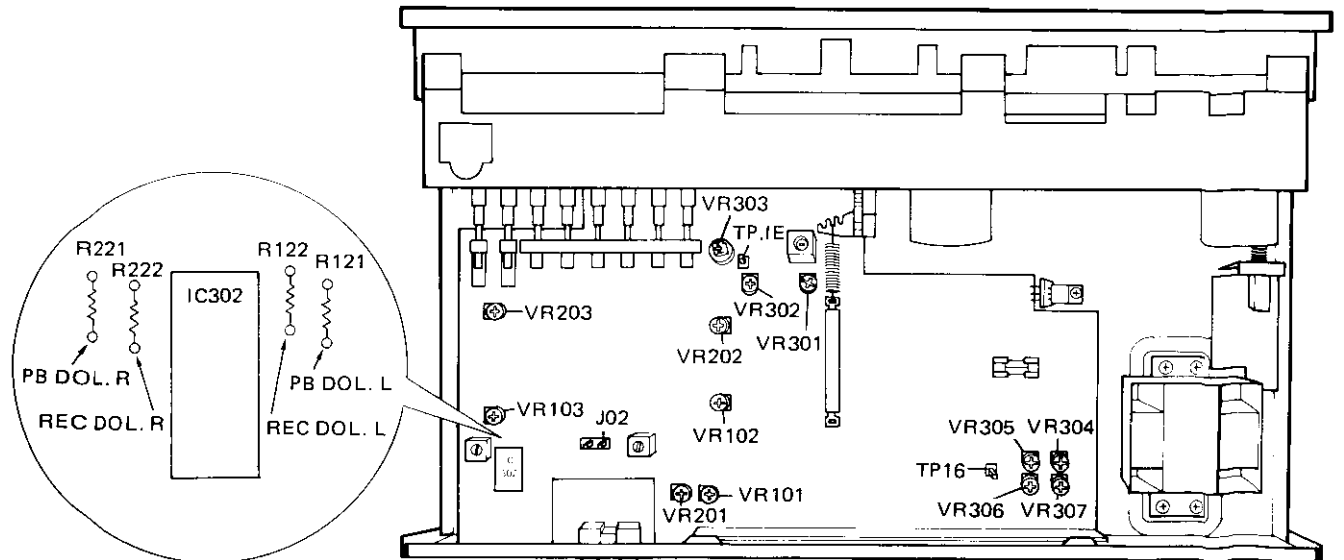

Fig. 11-8 Adjustments locations

Deck II

1. Head Azimuth Adjustment						
• Turn VR101 and VR201 to mechanical center positions.						
No.	Mode	Input signal & test tape	Adjustment location	Measuring location	Adjustment value	Remarks
1	PLAY	Play the 10kHz/-20dB section of the STD-331B test tape.	Head azimuth adjustment screw. (FWD, REV) (See Fig. 11-6).	LINE OUT	Maximum playback signal level.	
2	STOP	Lock the screw with screw lock after completing the adjustment.				
2. Playback frequency response check						
No.	Mode	Input signal & test tape	Adjustment location	Measuring location	Adjustment value	Remarks
1	PLAY	STD-331B	—	LINE OUT	The allowable zone showing in Fig. 11-7 is to be satisfied.	
3. Playback Level Adjustment						
• The adjustment determines the DOLBY NR level, and must be performed with great care.						
No.	Mode	Input signal & test tape	Adjustment location	Measuring location	Adjustment value	Remarks
1	PLAY	Play the 315Hz/0dB section of the STD-331B test tape.	VR102 (Lch) VR202 (Rch)	PB DOL, L (Lch) PB DOL, R (Rch)	-13.5dBv	
4. Playback Time Constant Switching Check						
• Put the deck into playback mode with no cassette loaded.						
• Check that the noise level changes at the line playback output terminals when the TAPE SELECTOR switch is changed.						
5. Erasure Current Adjustment						
No.	Mode	Input signal & test tape	Adjustment location	Measuring location	Adjustment value	Remarks
1	REC	Load the STD-610 standard tape without an input signal being applied.	VR303	TP,IE	180mV AC	(FWD)
6. Recording Bias Adjustment						
• After the adjustment, caution should be exercised so as not to become under bias by checking the distortion rate.						
No.	Mode	Input signal & test tape	Adjustment location	Measuring location	Adjustment value	Remarks
1	STOP	Set the TAPE SELECTOR switch to the NORM position.				
2	REC	STD-608A (NORM) -20dB	VR301 (Lch) VR302 (Rch)	LINE OUT	+1.0dB±0.5dB (6.3k/315Hz)	
7. Recording Level Adjustment						
No.	Mode	Input signal & test tape	Adjustment location	Measuring location	Adjustment value	Remarks
1	STOP	Set the TAPE SELECTOR switch to the NORM position.				
2	REC PAUSE	Apply a 315Hz/-10dBv (316mV) signal to the Line Input terminals.	Rec Level control	REC DOL, L (Lch) REC DOL, R (Rch)	-13.5dBv	
3		Set the DOLBY NR switch to the ON position. (DOLBY B)				
4	REC/ PLAY	Record the above signal level onto the STD-608A test tape, and playback.	VR103 (Lch) VR203 (Rch)	REC DOL, L (Lch) REC DOL, R (Rch)	-13.5dBv	

5		Set the TAPE SELECTOR switch to the CrO ₂ position.				
6	REC/ PLAY	Record the above signal onto the STD-620 test tape, and playback.	Confirm	REC DOL, L (Lch) REC DOL, R (Rch)	-13.5dBv±1.5dB	
7		Set the TAPE SELECTOR switch to the METAL position.				
8	REC/ PLAY	Record the above signal onto the STD-610 test tape, and playback.	Confirm	REC DOL, L (Lch) REC DOL, R (Rch)	-13.5dBv±1.5dB	
8. Recording and Playback Frequency Response Check						
No.	Mode	Input signal & test tape	Adjustment location	Measuring location	Adjustment value	Remarks
1	STOP	Set the TAPE SELECTOR switch to the NORM position.				
2	REC/ PLAY	STD-608A (NORM) NR: OFF/ON (TYPE B, C)	—	LINE OUT	The allowable zone shown in Fig. 11-9 is to be satisfied.	
3		Set the TAPE SELECTOR switch to the CrO ₂ position.				
4	REC/ PLAY	STD-620 (CrO ₂) NR: OFF/ON (TYPE B, C)	—	LINE OUT	The allowable zone shown in Fig. 11-9 is to be satisfied.	
5	STOP	Set the TAPE SELECTOR switch to METAL position.				
6	REC/ PLAY	STD-610 (METAL) NR: OFF/ON (TYPE B, C)	—	LINE OUT	The allowable zone shown in Fig. 11-9 is to be satisfied.	
9. Copy Mode Frequency Response Check						
<ul style="list-style-type: none"> • Playback after making copy should be carried out by on the REC/PB side. 						
No.	Mode	Input signal & test tape	Adjustment location	Measuring location	Adjustment value	Remarks
1	STOP	Set the TAPE SELECTOR switch to the NORM position.				
2	COPY & HIGH SPEED	Load the STD-331B test tape into deck I, and the STD-608A test tape into deck II.	—	—	Copy recorded signal from STD-331B (at both normal and double speeds).	
3	PLAY (Deck II)	Play the signal recorded on the STD-608A test tape in the previous adjustment procedure.	—	LINE OUT	The allowable zone shown in Fig. 11-10 is to be satisfied.	
4	STOP	Set the TAPE SELECTOR switch to the CrO ₂ position.				
5		Load the STD-620 test tape into deck II, and repeat steps 1 and 2 to check that the allowable zone shown in Fig. 11-10 is satisfied.				
6	STOP	Set the TAPE SELECTOR switch to the METAL position.				
7		Load the STD-610 test tape into deck II, and repeat steps 1 and 2 to check that the allowable zone shown in Fig. 11-10 is satisfied.				
10. Level Meter Check						
No.	Mode	Input signal & test tape	Adjustment location	Measuring location	Adjustment value	Remarks
1	REC- PAUSE	Apply a 315Hz/-10dBv (316mV) signal to the LINE INPUT terminals.	REC LEVEL control	REC DOL, L (Lch) REC DOL, R (Rch)	Check that the level meters "1dB" light up within -13.5dBv±2dB of the signal output level.	

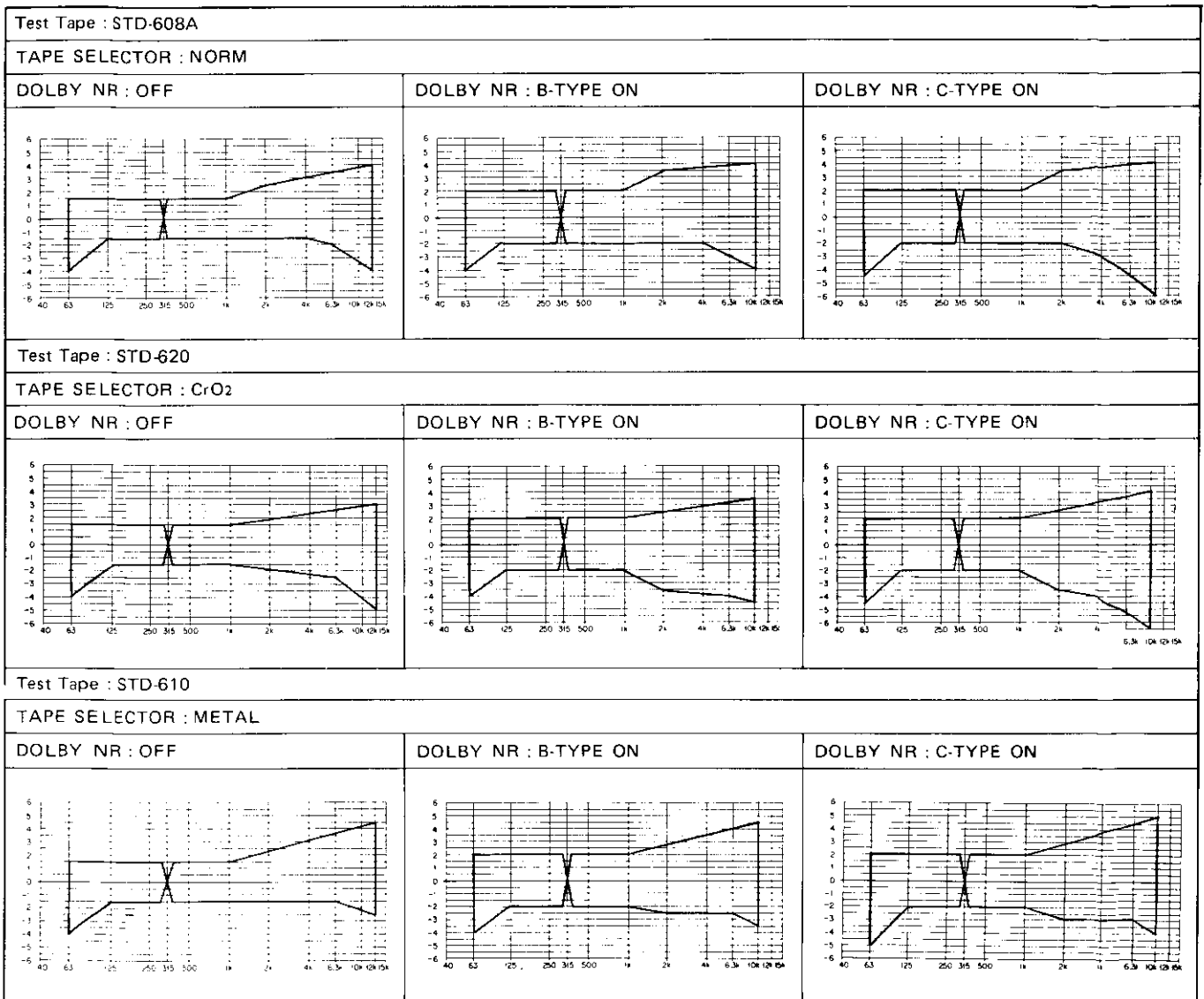

Fig. 11-9 Allowable recording and playback frequency response zone

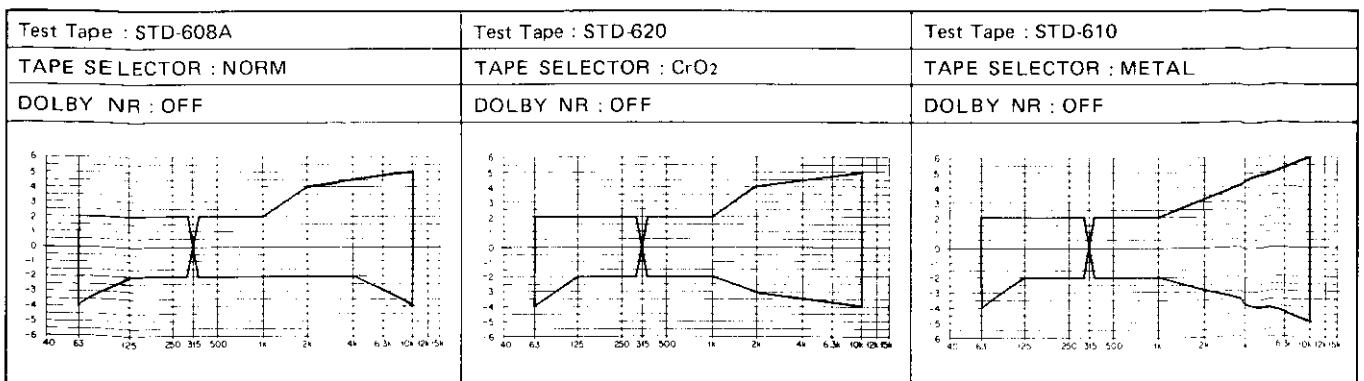

Fig. 11-10 Copy mode allowable recording and playback frequency response zone

11. RÉGLAGES MÉCANIQUES

11.1 RÉGLAGE MÉCANIQUE

Contrôle et Réglage de l'Amortisseur de Trappe

Placer le ressort de trappe du côté de la platine 1 sur la position (B) comme indiqué dans la Fig. 11-2. Redresser ensuite verticalement l'ensemble A du panneau avant comme indiqué dans la Fig. 11-1. Ouvrir les trappes de la platine 1 et de la platine 2 en même temps. A ce point, s'assurer que la différence entre le degré d'ouverture des deux trappes est de moins de 17mm lorsqu'un côté de la trappe est complètement ouvert. Lorsque cette valeur est différente de la valeur standard mentionnée, changer la position de mise en place du ressort de trappe de la platine 1 et effectuer un réglage comme suit:

- Lorsque l'action d'ouverture de la trappe de la platine 1 se fait plus lentement que celle de la platine 2: Changer (B) dans la Fig. 11-2 à (A).
- Lorsque l'action d'ouverture de la trappe de la platine 1 se fait plus rapidement que celle de la platine 2: Changer (B) dans la Fig. 11-2 à (C).

Réglage de la vitesse de bande

1. Mettre la bande d'essai STD-301 en place dans les platines 1 et 2.
2. Court-circuiter le TP.16 (×2 ADJ) et GND (masse), puis mettre la platine 1 dans le mode de reproduction (vitesse double) et ajuster avec VR307 de manière à ce que la fréquence atteigne $6000\text{Hz} \pm 10\text{Hz}$.
3. Arrêter la platine 1 et mettre la platine 2 dans le mode de reproduction à vitesse double, puis ajuster avec VR304 de manière à ce que la fréquence devienne celle de la platine $1 \pm 10\text{Hz}$.
4. Après avoir retiré le court-circuit mentionné à l'étape 2, mettre la platine 1 en mode de reproduction à vitesse normale et ajuster avec VR306 pour que sa fréquence devienne $3000\text{Hz} \pm 5\text{Hz}$.
5. Arrêter le fonctionnement de la platine 1 et mettre la platine 2 en mode de reproduction à vitesse normale, puis ajuster avec VR305 pour que la fréquence devienne celle de la platine $1 \pm 5\text{Hz}$.

(Platine 1)

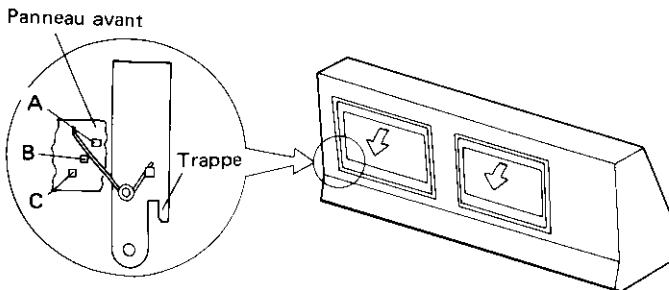

Fig. 11-2

Fig. 11-1

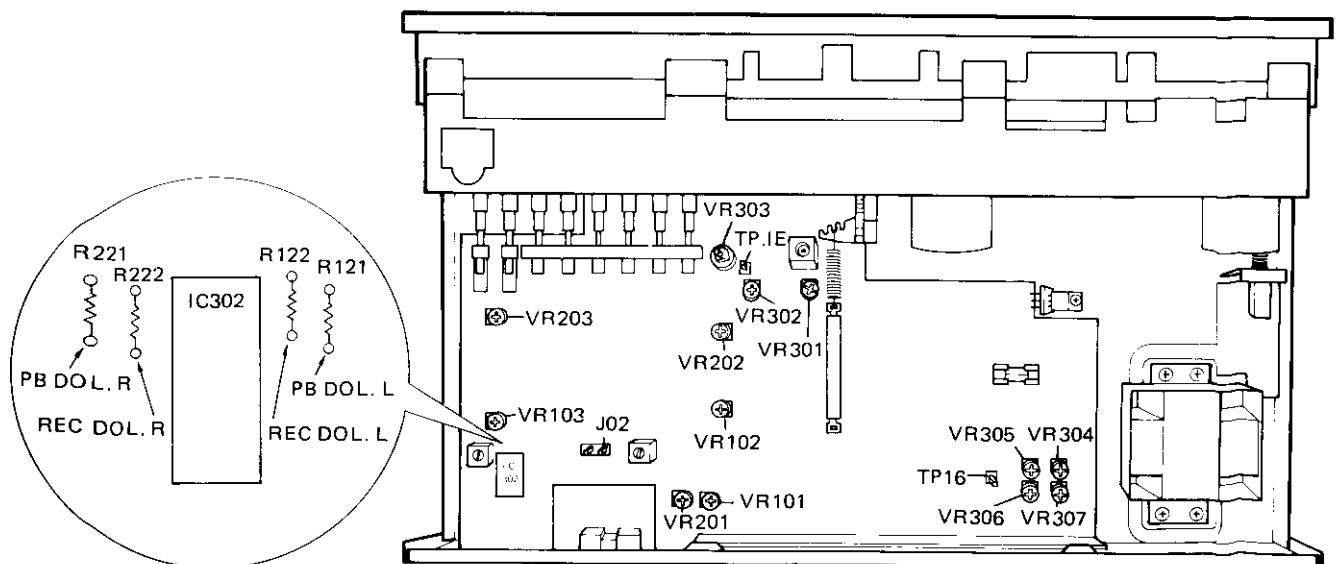

Fig. 11-3 Réglage de la vitesse de bande

Réglage de course de curseur d'enregistrement/reproduction (confirmation de génération de bruit lorsque REC → STOP)

En chargeant la STD-605A dans la platine 2, vérifier si un bruit est généré ou non lorsqu'elle est mise à l'état d'arrêt de l'état d'enregistrement.

Si un bruit parasite est généré, remplacer le ressort de connexion de curseur en la plaçant de la manière indiquée dans la Fig. 11-4 (S'assurer que le curseur est bien complètement tiré dans l'état d'enregistrement et qu'il retourne bien complètement à l'état d'arrêt.)

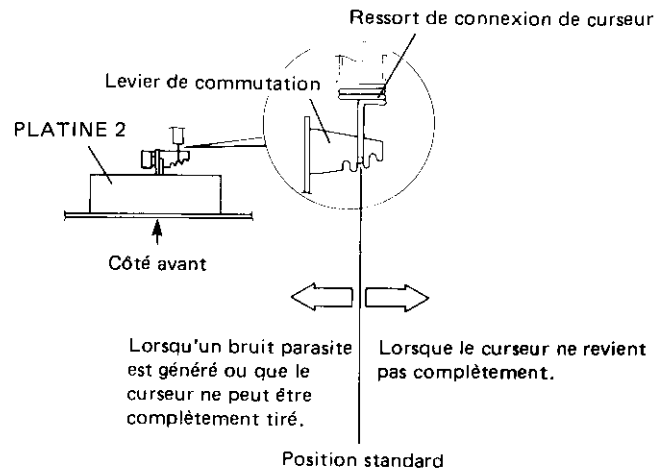

Fig. 11-4 Réglage de course de curseur d'enregistrement/reproduction (confirmation de génération de bruit lorsque REC → STOP)

11.2 RÉGLAGES ÉLECTRIQUES

Conditions nécessaires pour réaliser les réglages

1. Tous les réglages mécaniques doivent avoir été faits au préalable.
2. La tête magnétique doit être propre et démagnétisée.
3. Laisser chauffer les platines pendant quelques minutes avant de commencer les réglages électriques.
4. Caler le signal de référence à 0dBv=1V effi.
5. Raccorder une résistance de charge de 50 K-ohms (ou dans les limites comprises entre 47 à 52 K-ohms) aux bornes de sortie de ligne de lecture "OUTPUT".
6. A moins d'une indication contraire, les commutateurs mentionnés ci-dessous doivent se trouver sur les positions indiquées.

DOLBY NR : OFF
TAPE SELECTOR : NORM

Bandes d'étalonnage

- STD-331B : Réglages de lecture (voir la Fig. 11-5)
- STD-608A : Bande vierge ordinaire (NORMAL)
- STD-620 : Bande vierge au chrome (CrO₂)
- STD-610 : Bande vierge métallique (METAL)

Liste des réglages

Platine I

1. Réglage d'azimut de tête magnétique
2. Vérification de la réponse en fréquence de lecture
3. Réglage du niveau de lecture
4. Contrôle de commutation de constante de temps de lecture

Platine II

1. Réglage d'azimut de tête magnétique
2. Vérification de la réponse en fréquence de lecture
3. Réglage du niveau de lecture
4. Contrôle de commutation de constante de temps de lecture
5. Réglage du courant d'effacement
6. Réglage de la polarisation d'enregistrement
7. Réglage du niveau d'enregistrement
8. Vérification de la réponse en fréquence de lecture et d'enregistrement
9. Contrôle de réponse en fréquence de mode de duplication
10. Vérification de l'indicateur de niveau

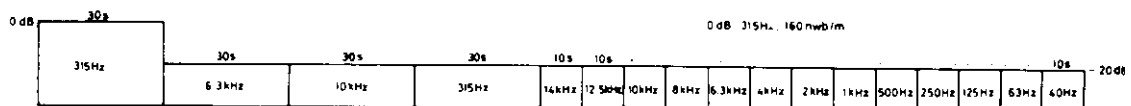

Fig. 11-5 Fréquences enregistrées sur la bande d'étalonnage STD-331B

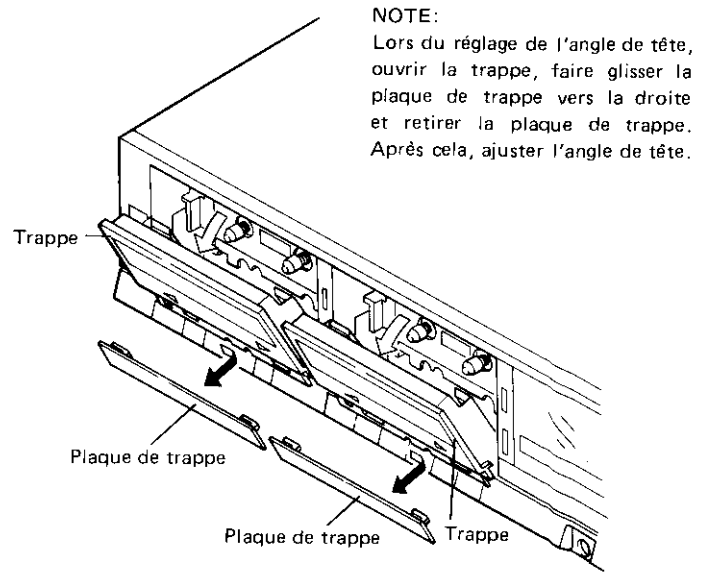
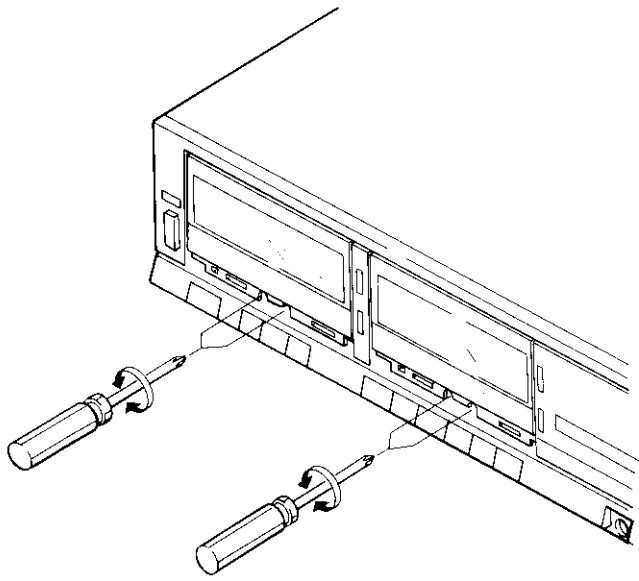

Fig. 11-6 Réglage d'azimut de tête

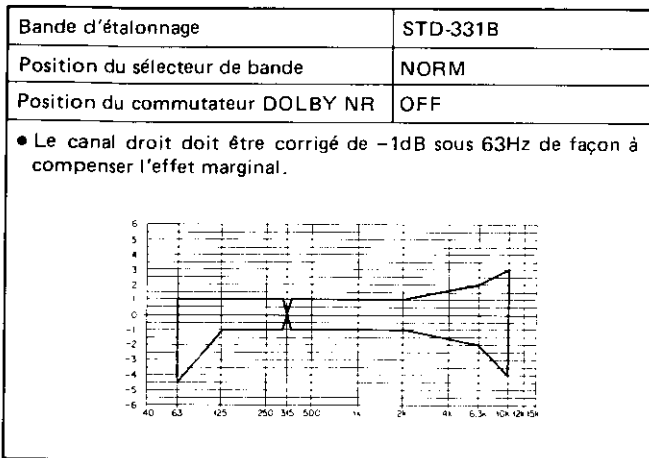

Fig. 11-7 Zone de tolérance de réponse en fréquence de lecture

Platine I

1. Réglage d'azimut de tête magnétique						
● Régler les résistances variables VR101 et VR201 de façon à obtenir la position centrale mécanique.						
No.	Mode	Signal appliqué et bande d'étalonnage	Emplacement du réglage	Emplacement de la borne de mesure	Valeur relevée	Observations
1	LECTURE	Lire le passage préenregistré de 10kHz/-20dB de la bande d'étalonnage STD-331B.	Vis de réglage d'azimut de tête, (FWD, REV)(voir la figure 11-5).	Sortie de ligne (LINE OUT)	Niveau maximum du signal de lecture.	
2	ARRÊT	Freiner la vis de réglage à l'aide d'un produit spécial lorsque le réglage est terminé.				
2. Vérification de la réponse en fréquence de lecture						
No.	Mode	Signal appliqué et bande d'étalonnage	Emplacement du réglage	Emplacement de la borne de mesure	Valeur relevée	Observations
1	LECTURE	STD-331B	—	Sortie de ligne (LINE OUT)	La zone autorisée indiquée à la Fig. 11-7 est à satisfaire.	
3. Réglage du niveau de lecture						
● Ce réglage servant à étalonner le niveau du DOLBY NR doit être exécuté avec une grande précision.						
No.	Mode	Signal appliqué et bande d'étalonnage	Emplacement du réglage	Emplacement de la borne de mesure	Valeur relevée	Observations
1	LECTURE	Lire le passage préenregistré de 315Hz/0dB de la bande d'étalonnage STD-331B.	VR101 (canal gauche) VR201 (canal droit)	PB. Dol, L (canal gauche) PB. Dol, R (canal droit)	-13,5dBv	
4. Contrôle de commutation de constante de temps de lecture						
● Mettre la platine en mode de lecture sans cassette chargée.						
● S'assurer que le niveau de bruit change aux bornes de sortie de lecture de ligne lorsque la position du sélecteur de bande (TAPE SELECTOR) est changée.						

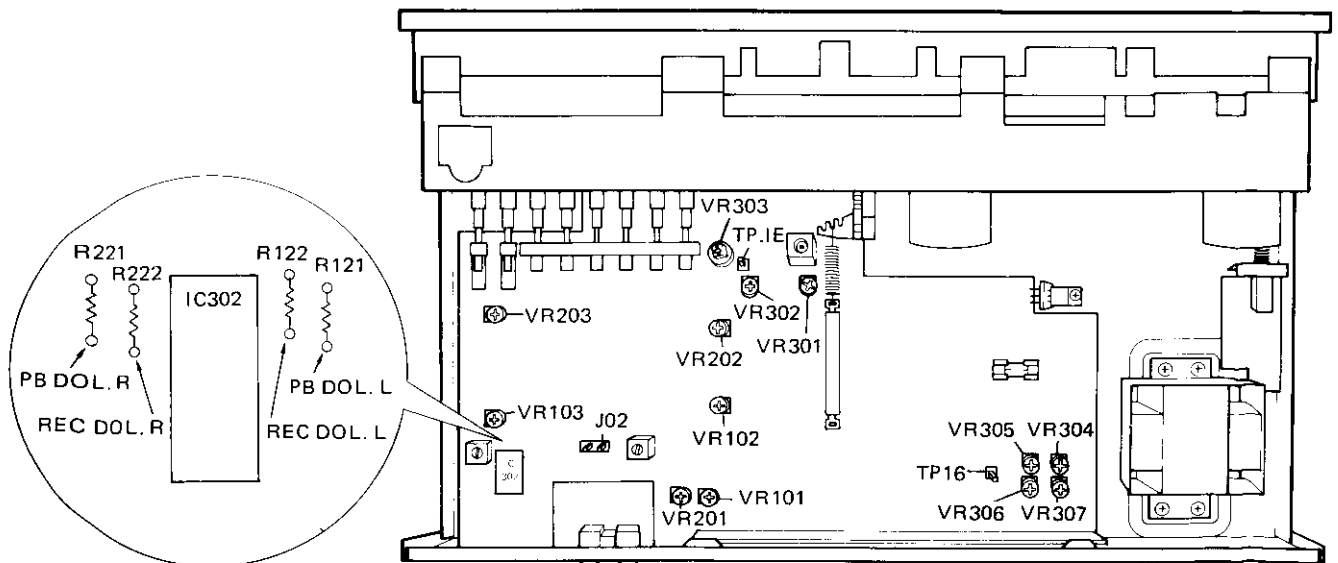

Fig. 11-8 Emplacement des réglages

Platine II

1. Réglage d'azimut de tête magnétique						
● Régler les résistances variables VR101 et VR201 de façon à obtenir la position centrale mécanique.						
No.	Mode	Signal appliqué et bande d'étalonnage	Emplacement du réglage	Emplacement de la borne de mesure	Valeur relevée	Observations
1	LECTURE	Lire le passage préenregistré de 10kHz/-20dB de la bande d'étalonnage STD-331B.	Vis de réglage d'azimut de tête. (FWD, REV)(voir la Fig. 11-6).	Bornes de sortie (OUTPUT).	Niveau maximum du signal de lecture.	
2	ARRÊT	Freiner la vis de réglage à l'aide d'un produit spécial lorsque le réglage est terminé.				
2. Vérification de la réponse en fréquence de lecture						
No.	Mode	Signal appliqué et bande d'étalonnage	Emplacement du réglage	Emplacement de la borne de mesure	Valeur relevée	Observations
1	LECTURE	STD-331B	—	Sortie de ligne (LINE OUT)	La zone autorisée indiquée à la Fig. 11-7 est à satisfaire.	
3. Réglage du niveau de lecture						
● Ce réglage servant à étalonner le niveau de DOLBY NR doit être exécuté avec une grande précision.						
No.	Mode	Signal appliqué et bande d'étalonnage	Emplacement du réglage	Emplacement de la borne de mesure	Valeur relevée	Observations
1	LECTURE	Lire le passage préenregistré de 315Hz/0dB de la bande d'étalonnage STD-331B.	VR102 (canal gauche) VR202 (canal droit)	PB. Dol, L (canal gauche) PB. Dol, R (canal droit)	-13,5dB	
4. Contrôle de commutation de constante de temps de lecture						
● Mettre la platine en mode de lecture sans cassette chargée.						
● S'assurer que le niveau de bruit change aux bornes de sortie de lecture de ligne lorsque la position du sélecteur de bande (TAPE SELECTOR) est changée.						
5. Réglage du courant d'effacement						
No.	Mode	Signal appliqué bande d'étalonnage	Emplacement du réglage	Emplacement de la borne de mesure	Valeur relevée	Observations
1	EN-REGISTREMENT/LECTURE	Charger la bande standard STA-610 sans appliquer de signal d'entrée.	VR303	TP.IE	180mV AC	(FWD)
6. Réglage de la polarisation d'enregistrement						
● Après le réglage, vérifier la déformation et s'assurer de ne pas tomber en-dessous de la valeur de polarisation.						
No.	Mode	Signal appliqué et bande d'étalonnage	Emplacement du réglage	Emplacement de la borne de mesure	Valeur relevée	Observations
1	ARRÊT	Placer le sélecteur de bande (TAPE SELECTOR) en position NORM.				
2	EN-REGISTREMENT	STD-608A (NORM) -20dB	VR301 (canal gauche) VR302 (canal droit)	Sortie de ligne (LINE OUT)	+1,0dB±0,5dB (6,3k/315Hz)	
7. Réglage du niveau d'enregistrement						
No.	Mode	Signal appliqué et bande d'étalonnage	Emplacement du réglage	Emplacement de la borne de mesure	Valeur relevée	Observations
1	ARRÊT	Placer le sélecteur de bande (TAPE SELECTOR) en position NORM.				
2	PAUSE A L'EN-REGISTREMENT	Appliquer un signal de 315 Hz/-10dBV (316mV) aux bornes d'entrée de ligne (LINE INPUT).	Potentiomètre de niveau d'enregistrement.	REC. Dol, L (canal gauche) REC. Dol, R (canal droit)	-13,5dB	
3		Régler le commutateur de DOLBY NR en position de marche. (DOLBY B)				
4	EN-REGISTREMENT/LECTURE	Enregistrer le signal mentionné plus haut sur la bande d'étalonnage STD-608A et lire ce passage.	VR103 (canal gauche) VR203 (canal droit)	REC. Dol, L (canal gauche) REC. Dol, R (canal droit)	-13,5dB	
5		Placer le sélecteur de bande (TAPE SELECTOR) en position CrO ₂ .				

6	EN-REGISTREMENT/LECTURE	Enregistrer le signal mentionné plus haut sur la bande d'étalonnage STD-620 et lire ce passage.	Confirmer	REC. DoI, L (canal gauche) REC. DoI, R (canal droit)	-13,5dB±1,5dB	
7		Placer le sélecteur de bande (TAPE SELECTOR) en position METAL.				
8	EN-REGISTREMENT/LECTURE	Enregistrer le signal mentionné plus haut sur la bande d'étalonnage STD-610 et lire ce passage.	Confirmer	REC. DoI, L (canal gauche) REC. DoI, R (canal droit)	-13,5dB±1,5dB	
8. Réglage de réponse en fréquence de lecture et d'enregistrement						
No.	Mode	Signal appliqué et bande d'étalonnage	Emplacement du réglage	Emplacement de la borne de mesure	Valeur relevée	Observations
1	ARRÊT	Placer le sélecteur de bande (TAPE SELECTOR) en position NORM.				
2	EN-REGISTREMENT/LECTURE	STD-608A (NORM) NR: Arrêt/marche (OFF/ON) (TYPE B, C)	—	Sortie de ligne (LINE OUT)	La zone autorisée indiquée à la Fig. 11-9 est à satisfaire.	
3		Placer le sélecteur de bande (TAPE SELECTOR) sur la position CrO ₂ .				
4	EN-REGISTREMENT/LECTURE	STD-620 (CrO ₂) NR: Arrêt/marche (OFF/ON) (TYPE B, C)	—	Sortie de ligne (LINE OUT)	La zone autorisée indiquée à la Fig. 11-9 est à satisfaire.	
5	ARRÊT	Placer le sélecteur de bande (TAPE SELECTOR) sur la position METAL.				
6	EN-REGISTREMENT/LECTURE	STD-610 (METAL) NR: Arrêt/marche (OFF/ON) (TYPE B, C)	—	Sortie de ligne (LINE OUT)	La zone autorisée indiquée à la Fig. 11-9 est à satisfaire.	
9. Contrôle de réponse en fréquence du mode de duplication						
● Effectuer la lecture après avoir terminé la copie (côté REC/PB).						
No.	Mode	Signal appliqué et bande d'étalonnage	Emplacement du réglage	Emplacement de la borne de mesure	Valeur relevée	Observations
1	ARRÊT	Placer le sélecteur de bande (TAPE SELECTOR) en position NORM.				
2	DUPLICATION ET DUPLICATION À GRANDE VITESSE	Charger la bande d'étalonnage STD-331B dans la platine I et la bande d'étalonnage STD-608A dans la platine II.	—	—	Effectuer une copie du signal préenregistré sur la bande STD-331B (à la vitesse normale et la vitesse double).	
3	LECTURE (platine II)	Lire le signal préenregistré de la bande d'étalonnage STD-608A du réglage précédent.	—	Sortie de ligne (LINE OUT)	La zone autorisée indiquée à la Fig. 11-10 doit être satisfaite.	
4	ARRÊT	Placer le sélecteur de bande (TAPE SELECTOR) en position CrO ₂ .				
5		Charger la bande d'étalonnage STD-620 dans la platine II et refaire les réglages 1 et 2 mentionnés plus haut pour s'assurer que la valeur se trouve dans les limites admissibles représentées sur la figure 11-10.				
6	ARRÊT	Placer le sélecteur de bande (TAPE SELECTOR) en position METAL.				
7		Charger la bande d'étalonnage STD-610 dans la platine II et refaire les réglages 1 et 2 mentionnés plus haut pour s'assurer que la valeur se trouve dans les limites admissibles représentées sur la figure 11-10.				
10. Contrôle de décibelmètre						
No.	Mode	Signal appliqué et bande d'étalonnage	Emplacement du réglage	Emplacement de la borne de mesure	Valeur relevée	Observations
1	PAUSE À L'EN-REGISTREMENT	Appliquer un signal de 315 Hz/-10dB (316mV) aux bornes d'entrée de ligne (LINE INPUT).	Potentiomètre de niveau d'enregistrement. (REC LEVEL)	REC. DoI, L (canal gauche) REC. DoI, R (canal droit)	S'assurer que les voyants "0dB" des décibelmètres s'allument dans les limites de -13,5 dBv ±2dB du niveau de sortie du signal.	

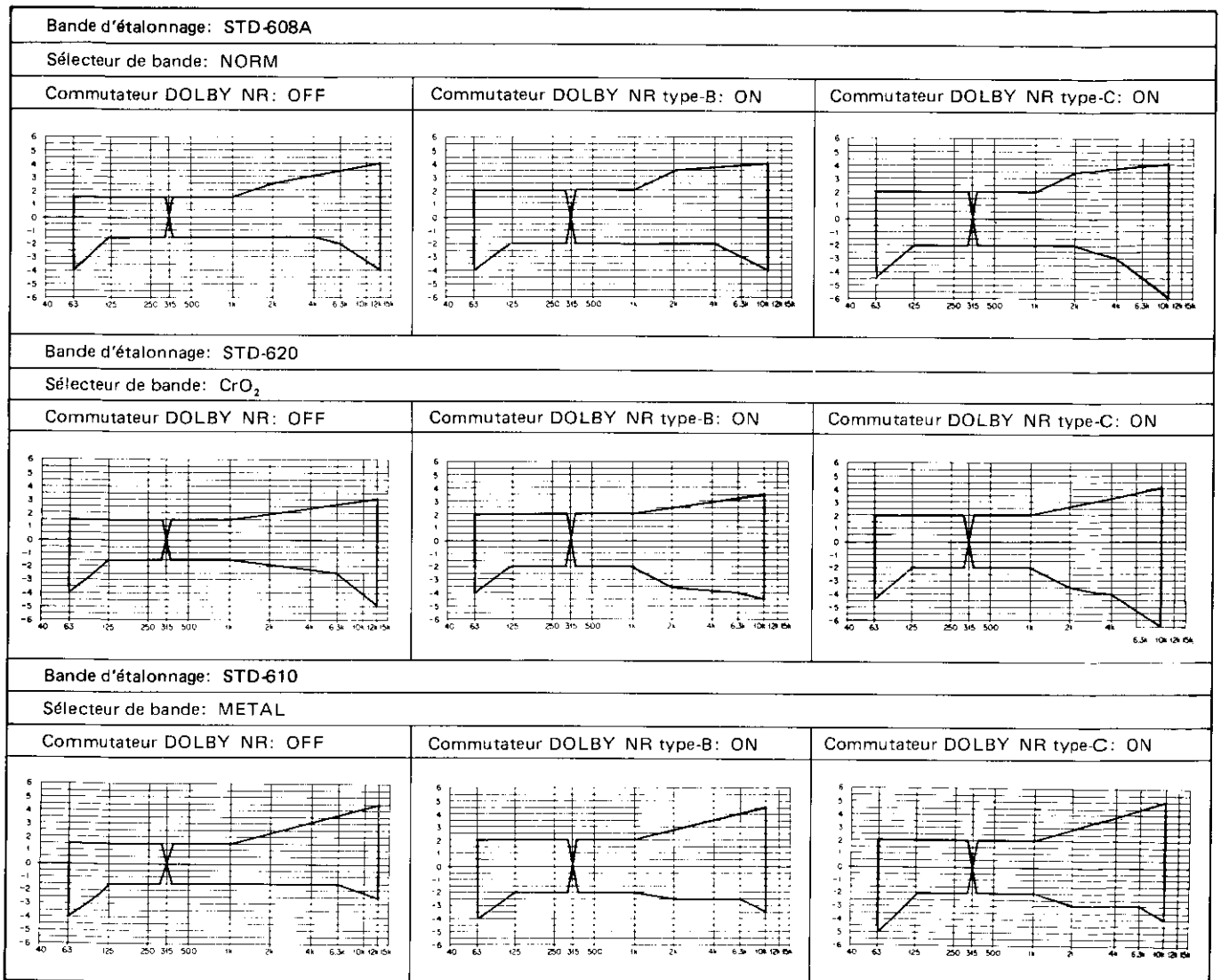

Fig. 11-9 Zone admissible de réponse en fréquence d'enregistrement et de lecture

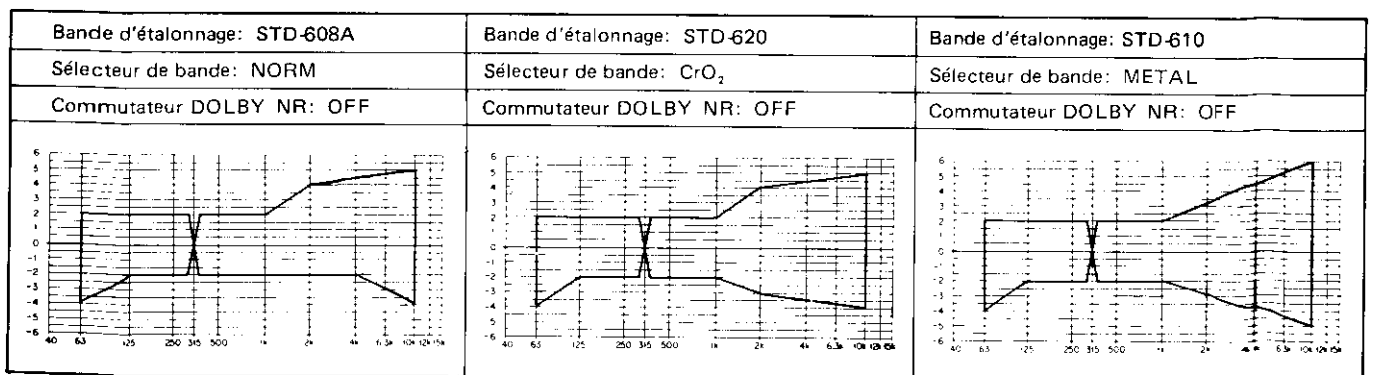

Fig. 11-10 Zone admissible de réponse en fréquence d'enregistrement et de lecture de mode de duplication

11. AJUSTES MÉCANICOS

11.1 AJUSTES MECANICOS

Comprobación y ajuste de la amortiguación de la puerta

Ajuste el resorte de la puerta del DECK 1 en la posición (B) como se muestra en la Fig. 11-2. Luego, levante verticalmente el conjunto A del panel frontal como se muestra en la Fig. 11-1. Abra las puertas de los DECK 1 y DECK 2 al mismo tiempo. Entonces, confirme que la diferencia entre el grado de abertura de ambas puertas sea de 17mm como máximo cuando se abre por completo un lado de la puerta. Cuando no se satisfacen estas medidas, cambie la posición de instalación del resorte de la puerta del DECK 1 y efectúe el ajuste del modo siguiente:

- Cuando la acción de abrir la puerta del DECK 1 es más retardada que la del DECK 2: Cambie (B) de la Fig. 11-2 a la de (A).
- Cuando la acción de abrir la puerta del DECK 1 es más rápida que la del DECK 2: Cambie (B) de la Fig. 11-2 a la de (C).

(Deck 1)

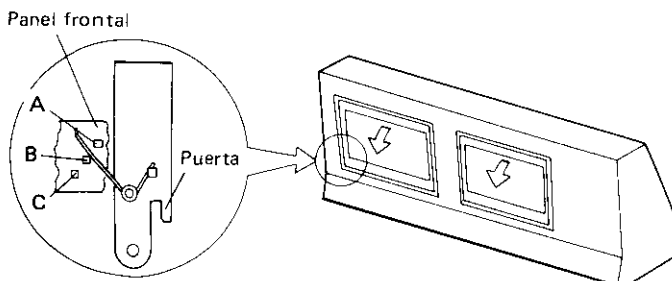

Fig. 11-2

Fig. 11-1

Ajuste de la velocidad de la cinta

1. Coloque la cinta de prueba STD-301 en los DECKs 1 y 2.
2. Cortocircuite los terminales TP.16 (×2 ADJ) y GND y establezca entonces el DECK 1 en el estado de reproducción (a doble velocidad), y ajuste con VR307 de modo que la frecuencia pase a ser $6000\text{Hz} \pm 10\text{Hz}$.
3. Detenga la operación del DECK 1 y establezca entonces el DECK 2 en el estado de reproducción (PLAY) (a doble velocidad), y ajuste el VR304 de modo que la frecuencia sea de $\pm 10\text{Hz}$ con relación a la del DECK 1.
4. Después de desconectar el cortocircuito mencionado en el paso 2, establezca el DECK 1 en el estado de reproducción (PLAY) a velocidad normal, y ajuste el VR306 de modo que la frecuencia sea de $3000\text{Hz} \pm 5\text{Hz}$.
5. Detenga la operación del DECK 1 y establezca entonces el DECK 2 en el estado de reproducción (PLAY) a velocidad normal, y ajuste el VR305 de modo que la frecuencia sea de $\pm 5\text{Hz}$ con relación a la del DECK 1.

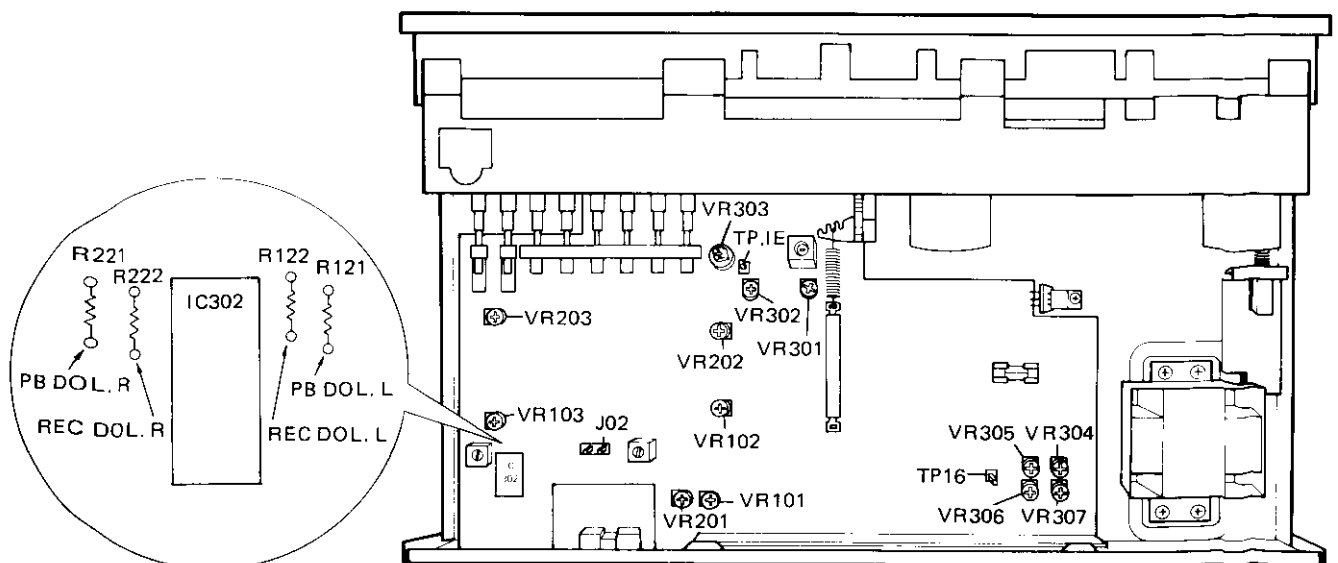

Fig. 11-3 Ajuste de la velocidad de la cinta

Ajuste de la carrera del selector deslizante de grabación/reproducción (confirmación de generación de ruido cuando se pasa de REC → STOP)

Mientras coloca la cinta STD-605A en el DECK 2, confirme si genera o no ruido cuando se establece en el modo de parada (STOP) desde el de grabación (REC).

En el caso de generarse ruido, reemplace el muelle de conexión del interruptor (SW) poniéndolo como se muestra en la figura 11-4. (Cerciórese de que el selector deslizante esté totalmente empujado durante el estado REC, y que haya vuelto completamente durante el estado STOP.)

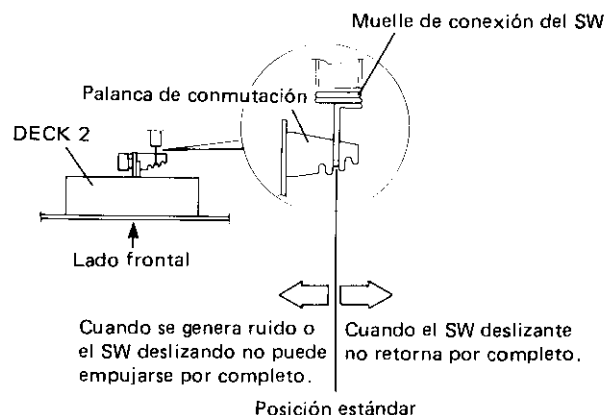

Fig. 11-4 Ajuste de la carrera del selector deslizante de grabación/reproducción (confirmación de generación de ruido cuando se pasa de REC → STOP)

11.2 AJUSTES ELECTRICOS

Condiciones para el ajuste

1. Los ajustes mecánicos deben terminarse primero.
2. El cabezal debe limpiarse y desimanarse.
3. Deje el deck por unos minutos antes iniciar los ajustes eléctricos.
4. La señal de referencia es de 0dBv=1Vrms.
5. Conecte una resistencia de carga de 50 kilo-ohmios (o entre 47 y 52 kilo-ohmios) a los terminales de salida.
6. A menos que se especifique de otra manera, los siguientes interruptores se dejan en las posiciones indicadas.

Interruptor DOLBY NR : OFF

TAPE SELECTOR : NORM

(SELECTOR DE CINTA)

Cintas de prueba

STD-331B : Ajustes de reproducción (Véase la Fig. 11-5)

STD-608A : Cinta en blanco NORMAL

STD-620 : Cinta en blanco CrO₂

STD-610 : Cinta en blanco METAL

Lista de ajustes

Deck I

1. Ajuste azimutal de la cabeza.
2. Comprobación de la respuesta en frecuencia de reproducción.
3. Ajuste del nivel de reproducción.
4. Inspección de conmutación constante del tiempo de reproducción.

Deck II

1. Ajuste azimutal de la cabeza.
2. Comprobación de la respuesta en frecuencia de reproducción.
3. Ajuste del nivel de reproducción.
4. Inspección de conmutación constante del tiempo de reproducción.
5. Ajuste de la corriente de borrado.
6. Ajuste de la polarización de grabación.
7. Ajuste del nivel de grabación.
8. Comprobación de la respuesta en frecuencia de grabación y reproducción.
9. Inspección de la respuesta en frecuencia en el modo de copia.
10. Comprobación del medidor de nivel.

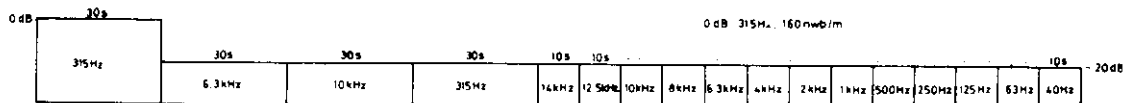

Fig. 11-5 Contenido de la cinta de prueba STD-331B

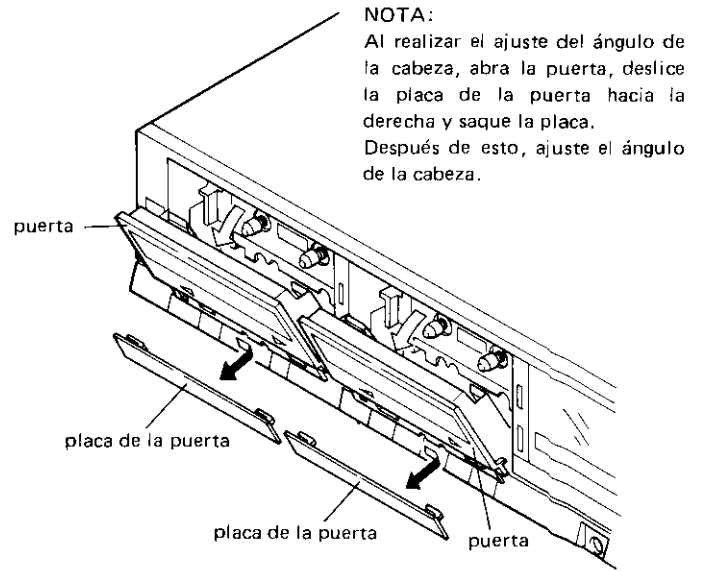
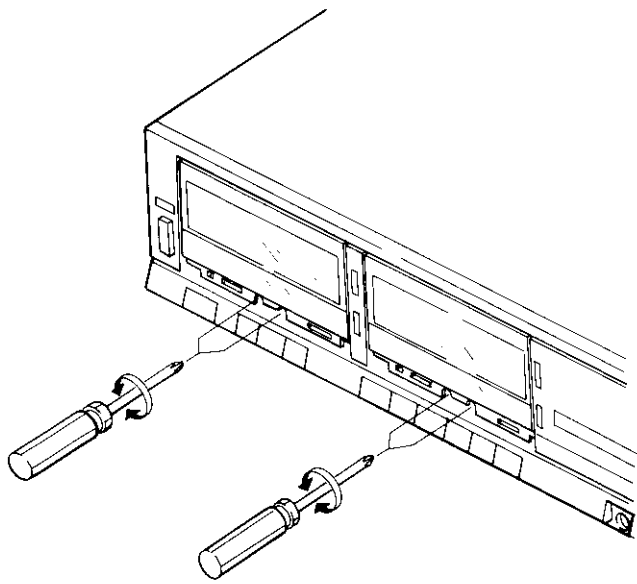

Fig. 11-6 Ajuste azimutal del cabeza

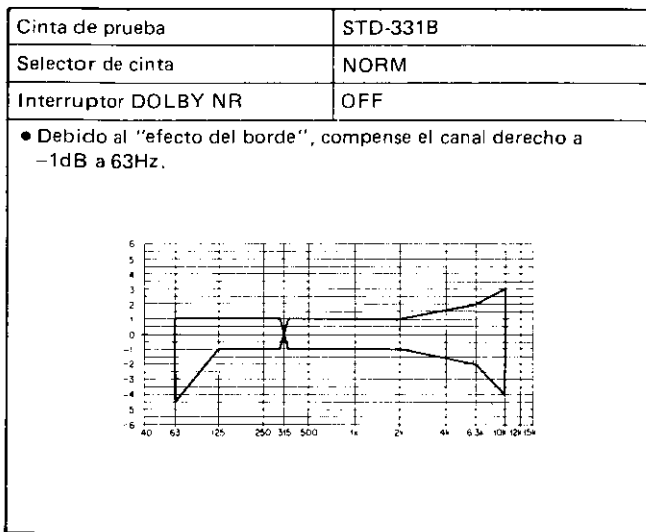

Fig. 11-7 Zona de respuesta en frecuencia de reproducción permisible

Deck I

1. Ajuste azimutal de la cabeza						
● Gire el VR101 y VR201 a la posición del centro mecánico.						
No	Modo	Señal de entrada y cinta de prueba	Punto de ajuste	Punto de medición	Valor de ajuste	Observaciones
1	Reproducción "PLAY"	Reproduzca la porción de 10kHz/-20dB de la cinta de prueba STD-331B.	Tornillo de ajuste azimutal de la cabeza. (FWD, REV) (Véase la Fig. 11-6).	Salida de línea (LINE OUT)	Máximo nivel de señal de reproducción.	
2	Parada "STOP"	Trabe el tornillo con el compuesto "screw lock" al término del ajuste.				
2. Comprobación de la respuesta en frecuencia de reproducción						
No	Modo	Señal de entrada y cinta de prueba	Punto de ajuste	Posición de medición	Valor de ajuste	Observaciones
1	Reproducción "PLAY"	STD-331B	-	Salida de línea (LINE OUT)	Debe satisfacerse la zona permisible mostrada en la Fig. 11-7.	
3. Ajuste del nivel de reproducción						
● Este ajuste determina el nivel de DOLBY NR, y debe efectuarse con cuidado.						
No	Modo	Señal de entrada y cinta de prueba	Punto de ajuste	Punto de medición	Valor de ajuste	Observaciones
1	Reproducción "PLAY"	Reproduzca la porción de 315Hz/0dB de la cinta de prueba STD-331B.	VR101 (Canal izquierdo) VR201 (Canal derecho)	PB (Repr.) DOL.L (Izq.) PB (Repr.) DOL.R (Der.)	-13,5dBv	
4. Comprobación de la conmutación constante de tiempo de reproducción						
● Establezca el deck en el modo de reproducción sin haber insertado ningún casete.						
● Compruebe que el nivel de ruido cambia en los terminales de salida de línea de reproducción cuando se cambia la posición del selector de cintas (TAPE SELECTOR).						

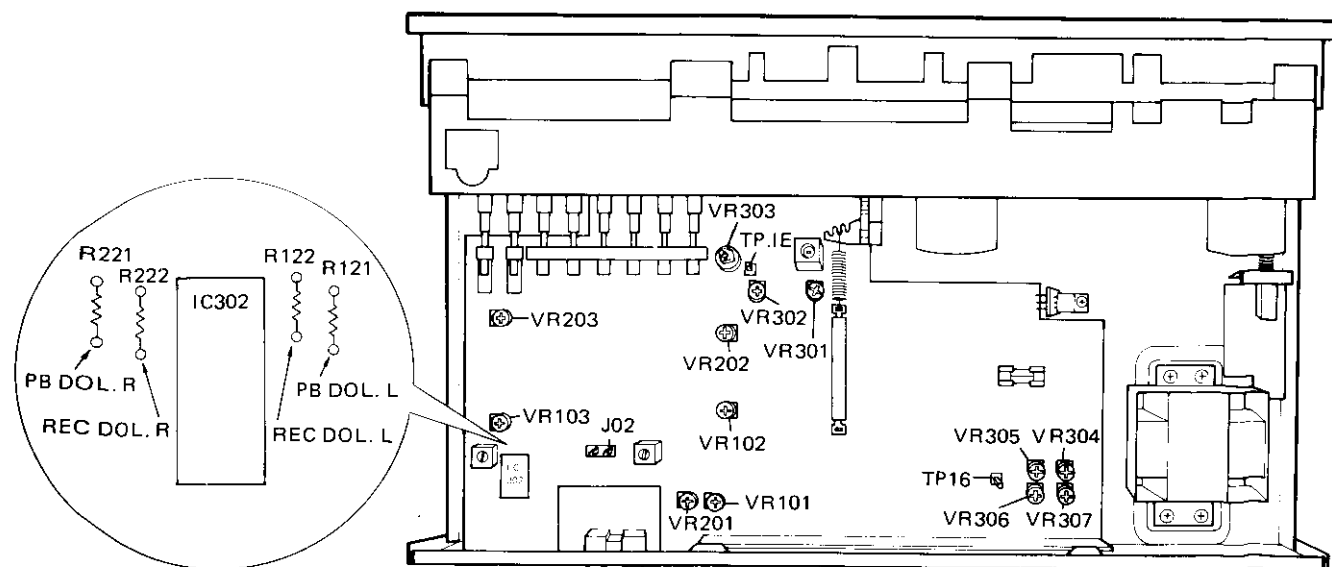

Fig. 11-8 Lugares de ajuste

Deck II

1. Ajuste azimutal de la cabeza						
• Gire el VR101 y VR201 a la posición del centro mecánico.						
No	Modo	Señal de entrada y cinta de prueba	Punto de ajuste	Punto de medición	Valor de ajuste	Observaciones
1	Reproducción "PLAY"	Reproduzca la porción de 10kHz/-20dB de la cinta de prueba STD-331B.	Tornillo de ajuste azimutal de la cabeza. (FWD, REV) (Véase la Fig. 11-6).	Salida de línea (LINE OUT)	Máximo nivel de señal de reproducción.	
2	Parada "STOP"	Trabe el tornillo con el compuesto "screw lock" al término del ajuste.				
2. Comprobación de la respuesta en frecuencia de reproducción.						
No	Modo	Señal de entrada y cinta de prueba	Punto de ajuste	Punto de medición	Valor de ajuste	Observaciones
1	Reproducción "PLAY"	STD-331B	—	Salida de línea (LINE OUT)	Debe satisfacerse la zona permisible mostrada en la Fig. 11-7.	
3. Ajuste del nivel de reproducción						
• Este ajuste determina el nivel de DOLBY NR, y debe efectuarse con cuidado.						
No	Modo	Señal de entrada y cinta de prueba	Punto de ajuste	Punto de medición	Valor de ajuste	Observaciones
1	Reproducción "PLAY"	Reproduzca la porción de 315Hz/0dB de la cinta de prueba STD-331B.	VR102 (Canal izquierdo) VR202 (Canal derecho)	PB (Repr.) DOL.L (Izq.) PB (Repr.) DOL.R (Der.)	-13,5dBv	
4. Comprobación de la conmutación constante de tiempo de reproducción						
• Establezca el deck en el modo de reproducción sin haber insertado ningún casete.						
• Compruebe que el nivel de ruido cambia en los terminales de salida de línea de reproducción cuando se cambia la posición del selector de cintas (TAPE SELECTOR.)						
5. Ajuste de la corriente de borrado						
No	Modo	Señal de entrada y cinta de prueba	Punto de ajuste	Punto de medición	Valor de ajuste	Observaciones
1	Grabación/reproducción "REC/PLAY"	Coloque la cinta de prueba estándar STA-610 sin aplicar ninguna señal de entrada.	VR303	TP.IE	180mV AC	(FWD)
6. Ajuste de la polarización de grabación						
• Después del ajuste, compruebe la distorsión y tenga cuidado en que no caiga por debajo de la polarización.						
No	Modo	Señal de entrada y cinta de prueba	Punto de ajuste	Posición de medición	Valor de ajuste	Observaciones
1	Parada "STOP"	Regule el interruptor selector de cinta "TAPE SELECTOR" a la posición NORM.				
2	Grabación "REC"	STD-608A (NORM) -20dB (grabación)	VR301 (Canal izquierdo) VR302 (Canal derecho)	Salida de línea (LINE OUT)	+1,0dB±0,5dB (6,3k/315Hz)	
7. Ajuste del nivel de grabación						
No	Modo	Señal de entrada y cinta de prueba	Punto de ajuste	Punto de medición	Valor de ajuste	Observaciones
1	Parada "STOP"	Regule el interruptor selector de cinta "TAPE SELECTOR" a la posición NORM.				
2	Grabación-pausa (REC-PAUSE)	Aplique una señal de 315Hz/-10dBv (316mV) a los terminales de entrada de línea (LINE INPUT).	Control del nivel de grabación (REC LEVEL).	REC (Grab.) DOL. L (Izq.) REC (Grab.) DOL. R (Der.)	-13,5dBv	
3		Regule el interruptor DOLBY NR a la posición ON. (DOLBY B)				
4	Grabación/reproducción "REC/PLAY"	Grabe el nivel de señal arriba mencionado en la cinta de prueba STD-608A y reproduzca.	VR103 (Canal izquierdo) VR203 (Canal derecho)	REC (Grab.) DOL.L (Izq.) REC (Grab.) DOL.R (Der.)	-13,5dBv	
5		Regule el interruptor selector de cinta "TAPE SELECTOR" a la posición CrO ₂ .				

6	Grabación/reproducción "REC/PLAY"	Grabe la señal arriba mencionada en la cinta de prueba STD-620, y reproduzca.	Confirme	REC (Grab.) DOL.L (Izq.) REC (Grab.) DOL.R (Der.)	-13,5dBv±1,5dBv	
7		Regule el interruptor selector de cinta "TAPE SELECTOR" a la posición METAL.				
8	Grabación/reproducción "REC/PLAY"	Grabe la señal arriba mencionada en la cinta de prueba STD-610 y reproduzca.	Confirme	REC (Grab.) DOL.L (Izq.) REC (Grab.) DOL.R (Der.)	-13,5dBv±1,5dBv	

8. Ajuste de la respuesta de grabación y reproducción

No	Modo	Señal de entrada y cinta de prueba	Punto de ajuste	Punto de medición	Valor de ajuste	Observaciones
1	Parada "STOP"	Regule el interruptor selector de cinta "TAPE SELECTOR" a la posición NORM.				
2	Grabación/reproducción "REC/PLAY"	STD-608A (NORM) NR: OFF/ON (TIPOS B, C)	—	Salida de línea (LINE OUT)	Debe satisfacerse la zona permisible mostrada en la Fig. 11-9.	
3	Parada	Ponga el selector TAPE SELECTOR en la posición CrO ₂ .				
4	Grabación/reproducción "REC/PLAY"	STD-620 (CrO ₂) NR: OFF/ON (TIPOS B, C)	—	Salida de línea (LINE OUT)	Debe satisfacerse la zona permisible mostrada en la Fig. 11-9.	
5	Parada "STOP"	Ponga el selector TAPE SELECTOR en la posición METAL.				
6	Grabación/reproducción "REC/PLAY"	STD-610 (METAL) NR: OFF/ON (TIPOS B, C)	—	Salida de línea (LINE OUT)	Debe satisfacerse la zona permisible mostrada en la Fig. 11-9.	

9. Inspección de la respuesta de frecuencia en el modo de copia

• Después del copiado, efectúe la reproducción (lado de Grab./Repr.)

No	Modo	Señal de entrada y cinta de prueba	Punto de ajuste	Punto de medición	Valor de ajuste	Observaciones
1	Parada "STOP"	Regule el interruptor selector de cinta "TAPE SELECTOR" a la posición NORM.				
2	COPIA Y COPIA DE ALTA VELOCIDAD	Coloque la cinta de prueba STD-331B en el deck I y la cinta de prueba STD-608A en el deck II.	—	—	Copie la señal grabada de la cinta de prueba STD-331B (en la velocidad normal y doble).	
3	Reproducción "PLAY" (Deck II)	Reproduzca la señal grabada en la cinta de prueba STD-608A en el procedimiento de ajuste anterior.	—	Salida de línea (LINE OUT)	Debe estar de acuerdo con la zona permisible mostrada en la Fig. 11-10.	
4	Parada "STOP"	Regule el interruptor selector de cinta "TAPE SELECTOR" a la posición CrO ₂ .				
5	Coloque la cinta de prueba STD-620 en el deck II, y repita los procedimientos 1 y 2 para confirmar que está de acuerdo con la zona permisible mostrada en la Fig. 11-10.					
6	Parada "STOP"	Regule el interruptor selector de cinta "TAPE SELECTOR" a la posición METAL.				
7	Coloque la cinta de prueba STD-610 en el deck II, y repita los procedimientos 1 y 2 para confirmar que está de acuerdo con la zona permisible mostrada en la Fig. 11-10.					

10. Inspección del indicador de nivel

	Modo	Señal de entrada y cinta de prueba	Punto de ajuste	Punto de medición	Valor de ajuste	Observaciones
1	Grabación/pausa "REC/PAUSE"	Aplice una señal de 315 Hz/-10dBv (316mV) a los terminales de entrada de línea "LINE INPUT".	Control del nivel de grabación "REC LEVEL".	REC (Grab.) DOL, L (Izq.) REC (Grab.) DOL, R (Der.)		Confirme que los indicadores de nivel "0dB" se encienden dentro de -13,5dBv±2dB del nivel de salida de señal.

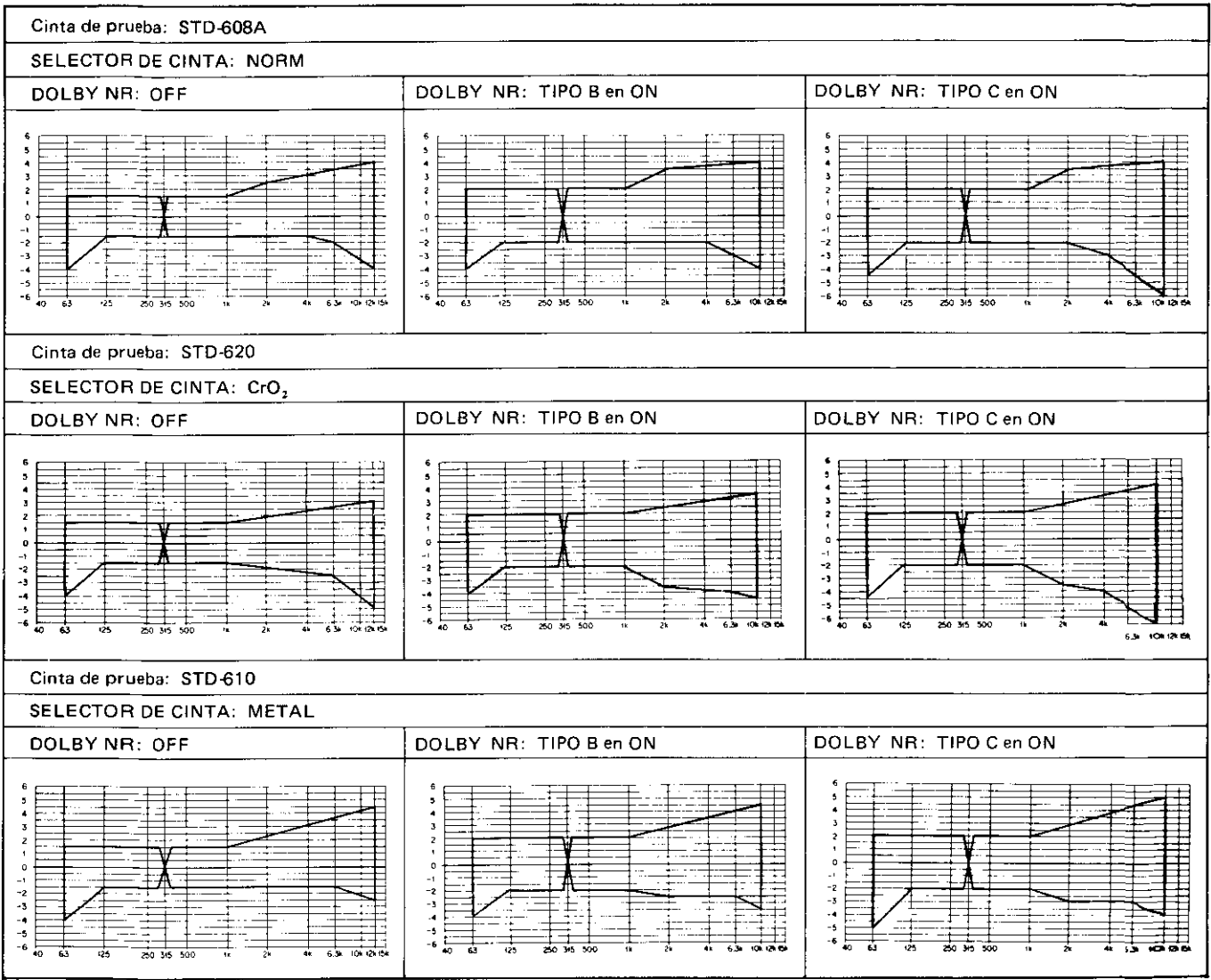

Fig. 11-9 Zona de respuesta en frecuencia de grabación y reproducción permisible

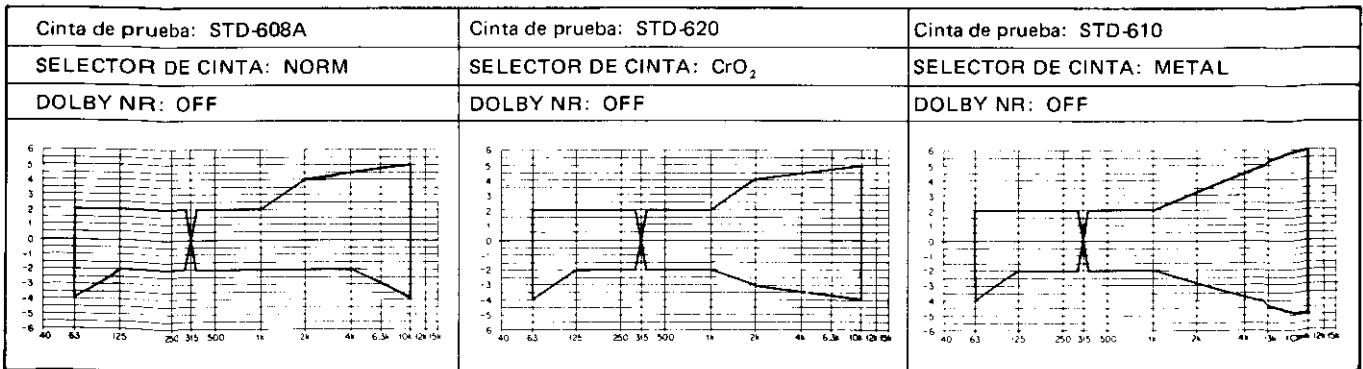

Fig. 11-10 Zona de respuesta en frecuencia de grabación y reproducción permisible en el modo de copia