

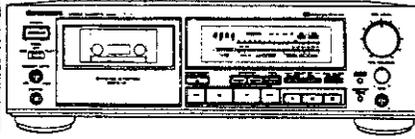

PIONEER
The future of sound and vision.

Service Manual



ORDER NO.
ARP1547

STEREO CASSETTE TAPE DECK

CT-737

CT-737-S

CT-737 AND CT-737-S HAVE TWO VERSIONS :

Type	Applicable model		Power requirement	Export destination
	CT-737	CT-737-S		
HEM	○	○	AC220V, 240V (switchable) *	European continent
HB	○	—	AC220V, 240V (switchable) *	United Kingdom

* Change the primary wiring of the power transformer.

- This manual is applicable to the HEM and HB types.
- For the CT-737/HB and CT-737-S/HEM types, refer to page 52.
- The CT-737-S is the same as the CT-737 except for the color.
- Ce manuel pour le service comprend les explications en français de réglage.
- Este manual de servicio trata del método ajuste escrito en español.

CONTENTS

1. SPECIFICATIONS	2
2. PANEL FACILITIES.....	3
3. PACKING	7
4. EXPLODED VIEWS AND PARTS LIST	8
5. SCHEMATIC DIAGRAM	15
6. P.C. BOARDS CONNECTION DIAGRAM.....	19
7. ELECTRICAL PARTS LIST	23
8. ADJUSTMENTS.....	31
8. RÉGRAGE	38
8. AJUSTE	45
9. FOR CT-737/HB AND CT-737-S/HEM TYPES..	52

PIONEER ELECTRONIC CORPORATION 4-1, Meguro 1-Chome, Meguro-ku, Tokyo 153, Japan
PIONEER ELECTRONICS SERVICE INC. P.O. Box 1760, Long Beach, California 90801 U.S.A.
PIONEER ELECTRONICS OF CANADA, INC. 505 Cochrane Drive, Markham, Ontario L3R 8E3 Canada
PIONEER ELECTRONIC [EUROPE] N.V. Keetberglaan 1, 2740 Beveren, Belgium
PIONEER ELECTRONICS AUSTRALIA PTY. LTD. 178-184 Boundary Road, Braeside, Victoria 3195, Australia TEL: [03] 580-9911

1. SPECIFICATIONS

Systems	4 track, 2-channel stereo
Heads	Hard permalloy recording/playback combination head × 1 Erasing head:(Ferrite head) × 1
Motors	DC servo capstan motor × 1 DC reel motor × 1 DC auxiliary motor × 1
Wow & Flutter	0.028%(WRMS) ±0.08%(DIN)
Fast winding time	Approximately 80 seconds (C-60 tape)
Frequency response (-20 dB recording)	
Metal tape	20 Hz to 21,000 Hz
Chrome tape	20 Hz to 20,000 Hz
Normal tape	20 Hz to 20,000 Hz
Signal-to-noise ratio	
DOLBY NR OFF	More than 58 dB
Noise Reduction Effect	
DOLBY NR B type ON	More than 10 dB (at 5 kHz)
DOLBY NR C type ON	More than 19 dB (at 5 kHz)
Harmonic distortion	No more than 0.6% (0 dB)
Input	LINE: 58 mV (Input impedance: 56 kΩ)
Output	LINE: 316 mV (Output impedance: 5.2 kΩ) Headphones: 0.8 mW (Load impedance 8Ω VR Max.)

Miscellaneous

Power Requirements	AC 240V, 50/60 Hz
Power Consumption	22W
Dimensions	420(W) × 133.5(H) × 372(D) mm
Weight (without package)	7.3 kg

Accessories

Operating instructions	1
Connecting cords	2

NOTE:

Specifications and design subject to possible modifications without notice, due to improvements.

2. PANEL FACILITIES

FRONT PANEL

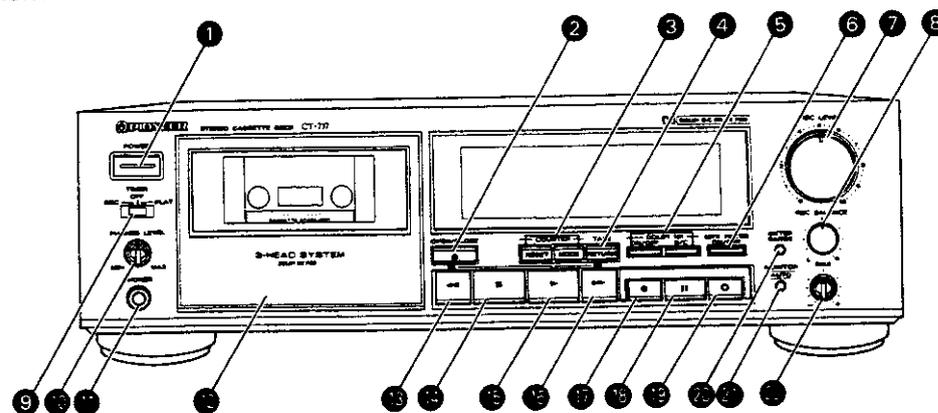

1 POWER switch

Turn the power on.

After the power is turned on, the dotted lines in the level meter flash for approximately 4 seconds until the circuits of the unit have stabilized. The unit will not operate during this time even if one of the operation buttons is pressed.

2 Cassette door OPEN/CLOSE button

NOTE:

If the cassette door is closed while the unit is turned OFF, and the power is then turned ON, the cassette door may open and close after pressing one of the operation buttons. This occurs when the microprocessor resets the door mechanism to its initial state and does not indicate any malfunctioning of the unit.

3 COUNTER selectors

To reset the displayed tape counter or time counter information.

RESET

Resets the counter indication to "0000."

MODE:

Selects one of the following two counter modes.

- Normal tape counter
- Time counter (displays the elapsed playback or recording time)

4 TAPE RETURN button

This button is used in the tape counter mode to fast forward or rewind the tape to a point near the counter reading "0000".

5 DOLBY NR selectors

ON/OFF:

Used to turn the Dolby NR system circuits ON or OFF.

B/C:

With the ON/OFF switch in the ON position, Dolby B or C can be selected with this switch.

6 MPX FILTER switch

This switch is effective only during recording with Dolby NR.

7 REC LEVEL control

8 REC BALANCE control

9 TIMER mode selector

REC:

Set to this position for timer recording.

PLAY:

Set to this position for timer playback.

OFF:

When the timer is not to be used, set the selector to this position. (Normally leave the selector in this position.)

10 PHONES LEVEL control

11 PHONES jack

12 Cassette door

13 Rewind (◀◀) button

Press this button to rewind the tape. When the button is pressed during playback, the tape rewinds to the beginning of the current selection, and playback starts. If the button is pressed twice, the tape rewinds to the selection before the current selection.

14 Stop (■) button

15 Play (▶) button

16 Fast forward (▶▶) button

Press this button to fast forward the tape. When the button is pressed during playback, the tape advances to the beginning of the next selection, and playback starts. If the button is pressed twice, the tape advances to the selection after the next selection.

17 Recording (●) button

When this button is pressed, the unit is set to one-touch recording pause (recording standby mode).

18 Pause (■) button

The tape transport can be momentarily stopped by pressing this button during recording or playback. Press the button again to restart operation. The button does not operate during fast forward or rewind.

19 Record muting (○) button

Press this button to create an unrecorded space during recording.

20 METER RANGE selector

Selects WIDE or EXPAND as scale range for the level meter.

21 MONITOR selector [AUTO]

For monitoring the sound during recording, this selector can be used to switch between source sound and just recorded sound.

22 Rec BIAS control

It is possible to adjust the bias according to the tape used and the source to be recorded.

OPERATING DISPLAY

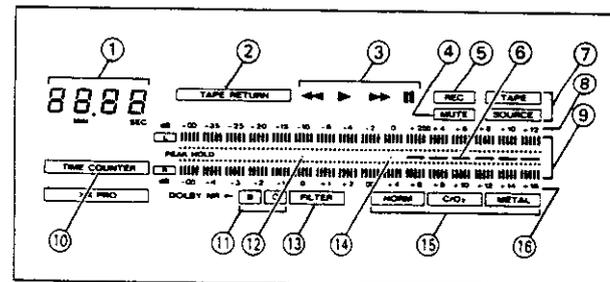

1 Counter

- The counter has two display modes.
- If the cassette door is open, the message "OPEN" is displayed.
- During music search the number of selections is displayed.

2 TAPE RETURN

Lights up during tape return operation.

3 Tape transport modes

- ◀◀ : Lights up when rewinding the tape.
- ▶ : Lights up during playback, playback pause, recording pause and recording. Flashes during music search.
- ▶▶ : Lights up when fast forwarding the tape.
- : Lights up in the pause mode.

4 MUTE

Flashes and lights during recording mute operation.

5 REC

Lights up during recording.

6 Warning zone

Changes according to the type of tape used and to the selected meter range.

7 Monitor source

TAPE: Recorded sound
SOURCE: Original source sound

8 Scale for WIDE range

- 9 Level
- L: Left channel
- R: Right channel

The mark indicates the reference level for the Dolby NR system.

10 TIME COUNTER

Lights up in the time counter mode.

11 DOLBY NR B/C

Indicates the selected Dolby Noise Reduction system, B or C

12 0 dB position for EXPAND range

13 MPX FILTER

Lights up when the MPX FILTER switch is pressed while the Dolby NR system is ON.

14 0 dB position for WIDE range

15 Tape type

The unit will automatically detect and display the tape type (NORMAL/CrO₂/METAL) of the cassette inserted. When no tape is inserted, METAL is displayed.

16 Scale for EXPAND range

CONNECTIONS

- Connection of input and output cords
- The cords to be used have white and red pin plugs.
 - Connect white plugs to the left channel (L), and red plugs to the right channel (R), making sure that the colors match. Take particular care to insert the plugs all the way in.

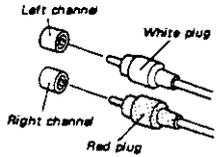

Connection to an audio timer
For details on the connection to an audio timer, refer to the instruction manual of the audio timer.

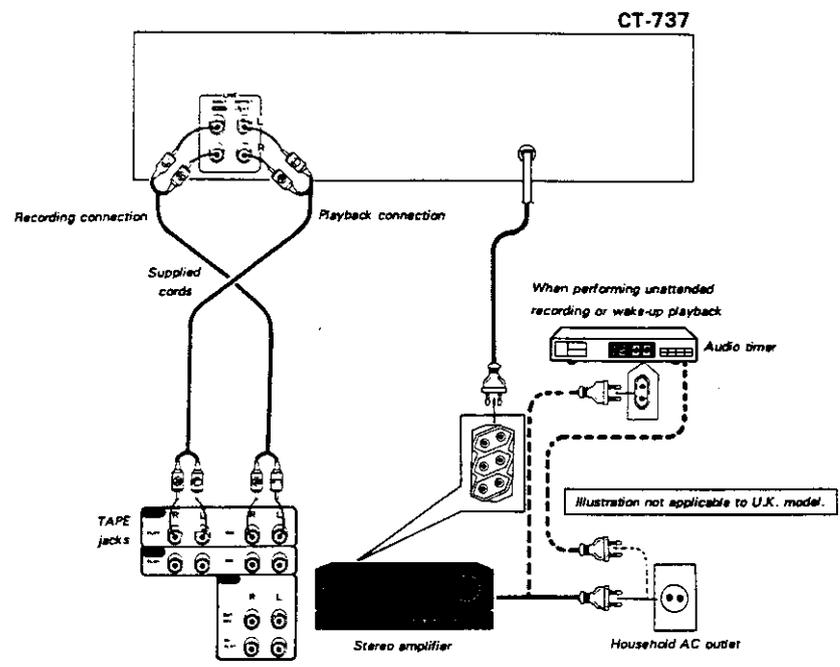

3. PACKING

Parts List

Mark	No.	Part No.	Description
	1	RHA1021	Pad (F)
	2	RHA1022	Pad (R)
	3	RHG1076	Packing case
	4	RHX-034	Packing sheet
	5	RRE1015	Operating instructions (English, French, German, Italian, Dutch, Spanish, Portuguese, Swedish)
	6	RDE-010	Connect cord
51			Connect cord assembly

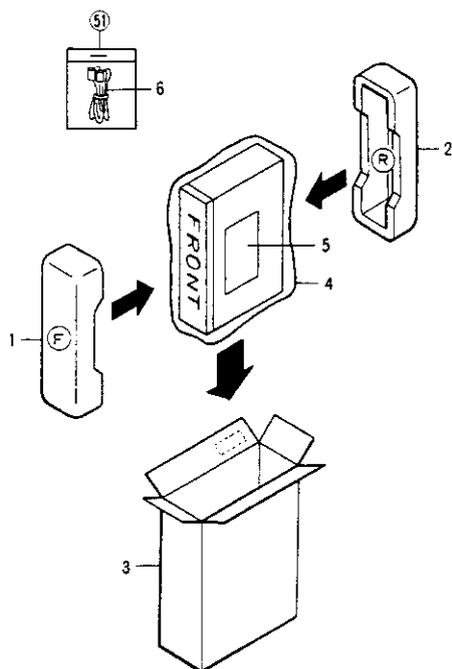

4. EXPLODED VIEWS AND PARTS LIST

4.1 EXTERIOR

NOTES:

- Parts without part number cannot be supplied.
- The Δ mark found on some component parts indicates the importance of the safety factor of the part. Therefore, when replacing, be sure to use parts of identical designation.
- For your parts Stock Control, the fast moving items are indicated with the marks **★★** and **★**.
★★ GENERALLY MOVES FASTER THAN ★.
- This classification shall be adjusted by each distributor because it depends on model number, temperature, humidity, etc.
- Parts marked by "⊙" are not always kept in stock. Their delivery time may be longer than usual or they may be unavailable.

Parts List of Exterior

Mark	No.	Part No.	Description	Mark	No.	Part No.	Description
	1	CM-22B	Strain relief	41	BBT30P080FZK	Screw	
Δ	2	PDG1003 (RDG-027)	AC Power cord	42	
Δ ★★	3	REK-099	Fuse (FU401, FU402/ 800mA)	43	FBT40P080FZK	Screw	
Δ ★★	4	REK-102	Fuse (FU403/1.6A)	44	BBZ26P080FZK	Screw	
Δ ★	5	RTT1052	Power transformer (T1)	101		Tape mechanism unit	
★	6	SLF-401C	Diode (D11)	102		P.C.B stud	
	7	DBK-106	Mounting plate	103		Power transformer sheet	
	8	PNB1109	Absorber B	104		Tape mechanism sheet	
	9	RBL-059	Cassette plate spring	105		Main chassis	
	10		106		Panel stay	
	11	REB-223	Cover cushion (D)	107		PC support	
	12	REB103B	Stabilizer B	108		Monitor button	
	13	REB1057	Rubber spacer (A)	109		Monitor button mold	
	14	REE1010	Label	110		Front panel	
	15	AMR1158	Leg assembly	111		Cassette panel	
	16	PAC1208	Knob (PHONES LEVEL)	112		Rear panel	
	17	RAC-668	Knob A (TIMER)	113		Headphone unit	
	18	RAC1203	Button (POWER)	114		Input VR unit	
	19	RAC1204	Button (DOLBY, MPX)	115		Main unit	
	20	RAC1232	Button (COUNTER)	116		Timer unit	
	21	RAC1206	Button (CONTROL)	117		Power SW unit	
	22	RAC1262	VR knob B	118		FL unit	
	23	RAH1184	FL filter	119		SW unit	
	24	RAP1003	Under escutcheon	120		PB Dolby unit	
	25	RNK1284	Door	121		REC Dolby unit	
	26	RNK1301	Button holder	122		Bias VR unit	
	27	RXA1158	VR knob assembly (A)	123		P.C.B base	
	28	RXA1160	Button assembly (MONITOR)	124		P.C.B holder (H15)	
	29	RAH1187	Door lens				
	30	RAH1198	FL panel				
	31	RAH1200	Side panel (L)				
	32	RAH1201	Side panel (R)				
	33	RAH1314	Door panel				
	34	RXX1115	Cassette plate assembly				
	35	RXX1092	Bonnet				
	36	RXX1111	Front panel assembly				
	37	RXX1113	Door assembly				
	38	BBZ40P080FCC	Screw				
	39	BBZ30P060FCC	Screw				
	40	IBZ30P080FCC	Screw				

4. 2 MECHANISM UNIT

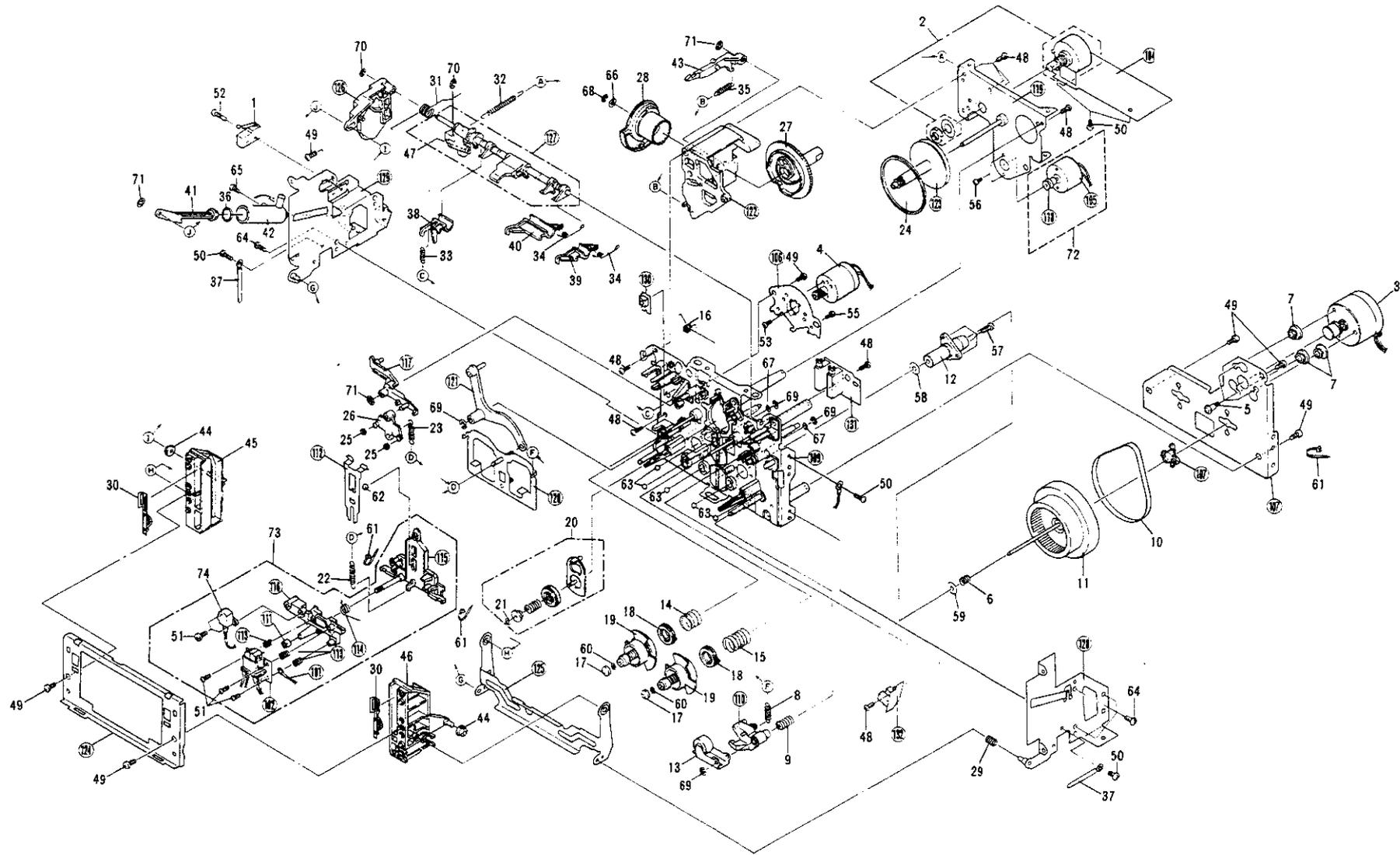

Part List of Mechanism Unit

Mark	No.	Part No.	Description	Mark	No.	Part No.	Description
★★	1	RSF-031	Micro switch	56	JGZ20P025FMC	Screw	
	2	RXK-C59	Rotary encoder	57	PMA26P050FZK	Screw	
	3	RXM1016	Capstan motor assembly	58	RBF-030	Oil stopper	
	4	RXM1018	Reel motor assembly	59	RBF-070	Thrust washer (B)	
	5	RBA-064	Step screw	60	RBF-076	Slider washer	
	6	RBL-044	Thrust spring	61	REC-371	Binder	
	7	REB-408	Rubber cushion	62	REF-022	Steel ball (φ 3)	
	8	RBL-028	Pinch spring	63	REF-023	Steel ball (φ 4)	
	9	RBL-030	Pinch thrust spring	64	VCT30P060FZK	Screw	
★★	10	REB-501	Capstan belt	65	VCZ26P080FMC	Screw	
	11	RXA1176	Flywheel assembly	66	WA26N070W040	Washer	
	12	RXB-362	Metal holder assembly A	67	WA32D080D050	Washer	
	13	RXB-676	Pinch roller arm (R) assembly	68	YE20FUC	E ring	
	14	RBL-031	BT spring (A)	69	YE25FUC	E ring	
	15	RBL-032	BT spring (B)	70	YE30FUC	E ring	
	16	RBL-033	Idler pressure spring	71	YS24F8T	Washer	
	17	RNK-815	Reel shaft cap B	72	RXX1055	Power motor assembly	
	18	RXB-751	BT disc assembly	73	RXX1103	Head base assembly	
	19	RXS-874	Reel base assembly	74	RPB1002	Erase head	
	20	RXB-875	Take-up idler assembly	101		Earth lead wire assembly	
	21	RBF-065	Polyslider washer	102		R/P head	
	22	RBL-037	Head base spring	103		
	23	RBL-038	Brake spring	104		Connector unit	
★★	24	REB-502	Drive belt	105		Power motor	
	25	REB-511	Brake shoe	106		Reel motor mounting plate	
	26	RNL-723	Brake	107		Flywheel holder	
	27	RNL-729	Cam gear	108		Thrust holder	
	28	RXB-884	Side cam gear assembly	109		Mechanism chassis assembly	
	29	RBL-045	Position spring	110		Pressure arm (R)	
	30	RBK1021	Half pressure spring	111		Adjustment nut	
	31	RBL-039	Eject spring	112		Head base pressure spring	
	32	RBL-040	Half pressure spring	113		Head adjust spring (C)	
	33	RBL-041	Rec arm spring	114		Height spring	
	34	RBL-042	Detect arm spring	115		Head base	
	35	RBL-043	Lock lever spring	116		Sub head base	
	36	REB-447	O ring	117		Brake lever	
	37	RNH-184	Cord clammer	118		First pulley	
	38	RNL-733	Rec detect arm	119		Gear chassis assembly	
	39	RNL-734	CO ₂ detect arm	120		Pinch base assembly	
	40	RNL-735	Metal detect arm	121		Pinch lever assembly	
	41	RNL-739	Piston	122		Gear base assembly	
	42	RNL-740	Cylinder	123		Second pulley assembly	
	43	RNL-741	Lock lever	124		Pocket frame	
	44	RNL-742	Collar	125		Door arm	
	45	RNL-849	Pocket (L)	126		Eject lever	
	46	RNL-850	Pocket (R)	127		Shift shaft assembly	
	47	RBF-C57	Polyslider washer	128		Door frame (R) assembly	
	48	BBZ26P080FZK	Screw	129		Door frame (L) assembly	
	49	BBZ30P080FZK	Screw	130		Rec switch unit	
	50	BCZ30P060FMC	Screw	131		Tape selector unit	
	51	PMZ20P080FZK	Screw	132		Sensor unit (A)	
	52	BMZ23P100FZK	Screw				
	53	BMZ26P030FZK	Screw				
	54				
	55	BMZ30P080FZK	Screw				

External Appearance of Transistors and ICs

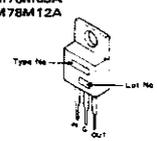
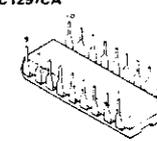
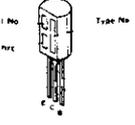
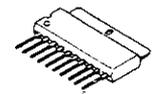
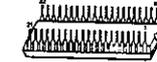
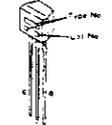
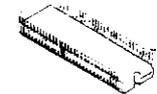
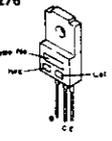
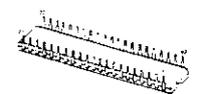
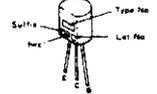
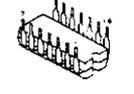
<p>2SA936</p> 	<p>BA335 BA6138</p> 	<p>NJM78M05A NJM78M12A</p> 	<p>μPC1297CA</p> 
<p>2SA1283 2SC3243</p> 	<p>BA6109</p> 	<p>CX20187</p> 	
<p>2SA1309A 2SC3311A</p> 	<p>DTC124ES DTA114ES DTC114ES</p> 	<p>PD4148</p> 	
<p>2SB950 2SD1276</p> 	<p>LC7570</p> 	<p>TC40508P</p> 	
<p>2SD1302</p> 	<p>M5218L M5220L M5233L</p> 	<p>TC40668P</p> 	

5. SCHEMATIC DIAGRAM

A

B

C

D

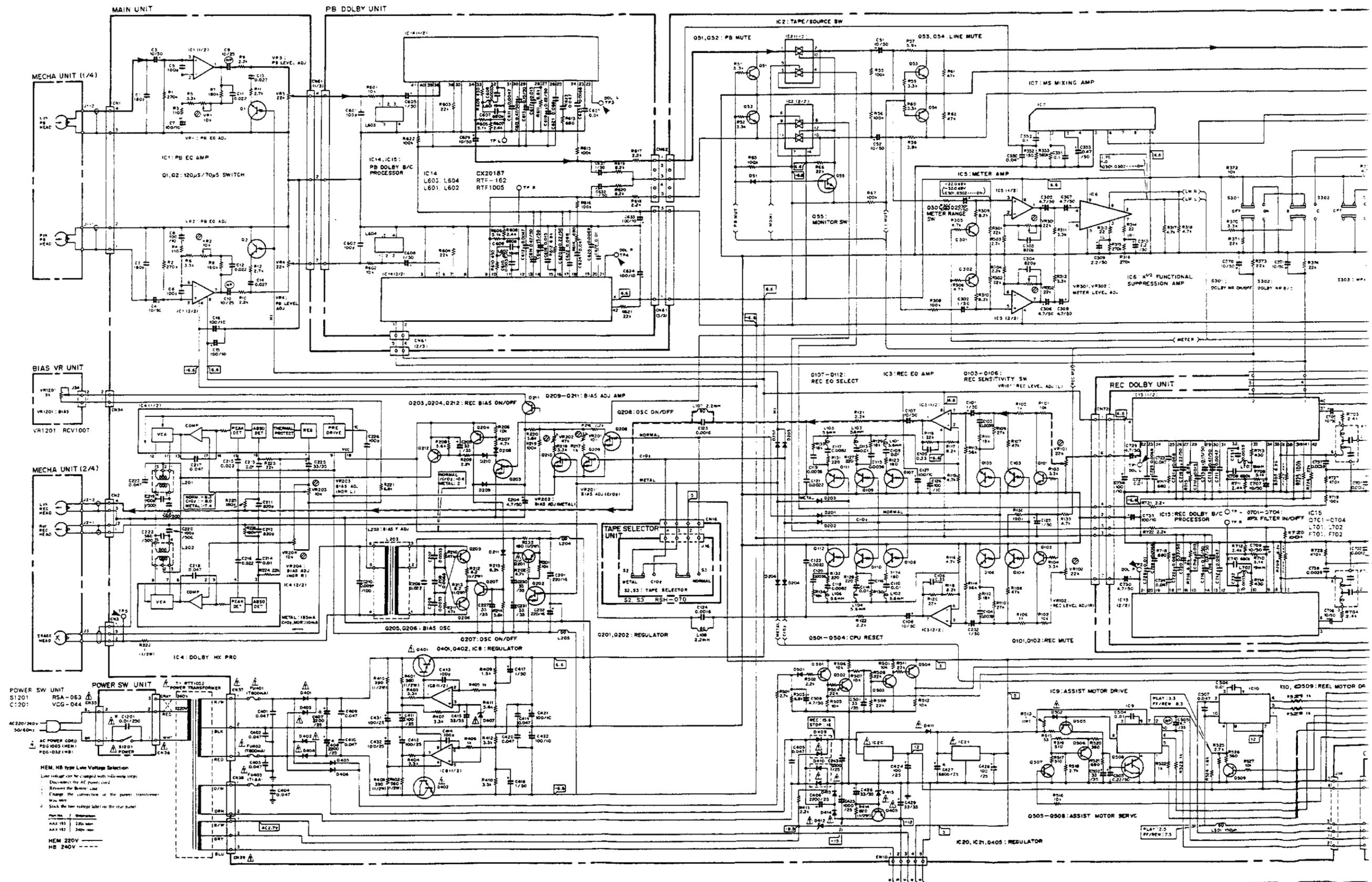

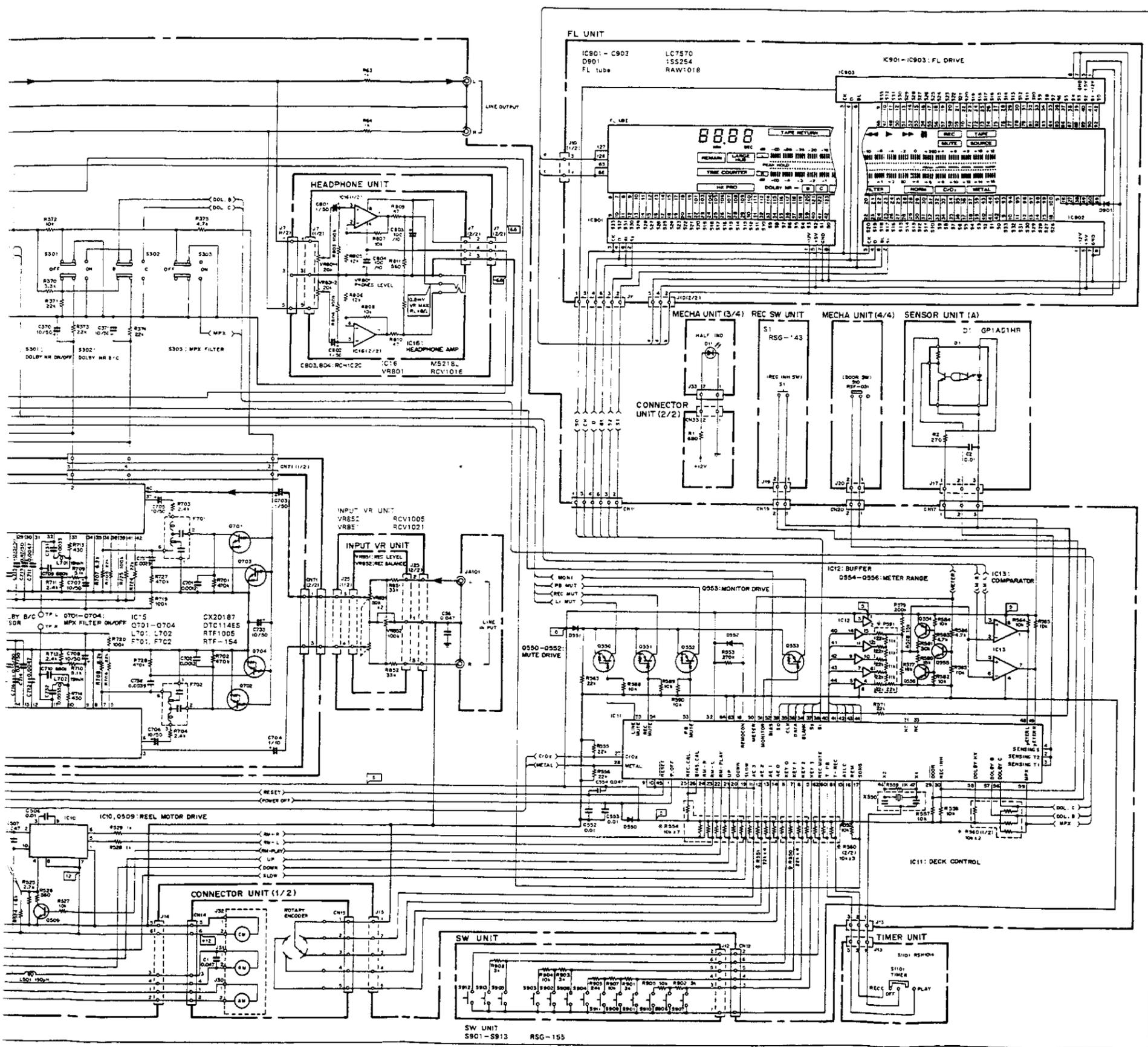

MAIN UNIT			
IC7	BA335	D401-D404	100F2FA9
IC9, IC10	BA6109	S301-S303	RSG1017
IC6	BA6138	L204, L205	LRA121K
IC1	M5220L	L201, L202	RTD1020
IC13	M5233L	L203	RTD1021
IC21	NJM78M05A	L107, L108	RTF1017
IC20	NJM78M12A	L101-L106	RTF1022
IC11	PD4148B	L501	RTF1068
IC12	TC4050BP	C427	RCH1010
IC2	TC4068BP	C407, C408	RCH1013
IC4	PC1297CA	VR1, VR2, VR201	VRT86VS103
IC3, IC5, IC8	M5218L	V203, V204	VRT86VS223
Q1, Q2, Q103-Q112	DTC114T5	VR3, VR4, VR101	VRT86VS473
Q55, Q202, Q203	DTC124E5	VR102, VR301, VR302	RCX1009
Q208-Q210		VR202	RCX1010
Q550-Q552	DTA114E5	R550, R551	VSS1014
Q201, Q405	2SA1283	R554, R560	
Q204, Q212, Q501	2SA1309A		
Q504-Q506, Q554			
Q508	2SA936		
Q402	2SB95C		
Q205, Q206	2SC3243		
Q211, Q301, Q302	2SC3311A		
Q502, Q503, Q507			
Q509, Q555, Q556			
Q401	2SD1276		
Q51-Q54, Q101	2SD1302		
Q102, Q207			
D407	H25CLL		
D415	MT213B		
D412	RD27E81		
D409	1B2C1-LC2		
D410	1B221-LC2		
D411, D413, D414	1SR35-100A		
D502			
D201-D211, D405	1S5254		
D406, D501, D550			
D551, D552, D51			

- RESISTORS**
Indicated in Ω, 1/4W, 1/8W, ±5% tolerance unless otherwise noted. k, M, M.O., (F), ±1%, (D), ±2%, (K) ±10%, (J) ±20% tolerance.
- CAPACITORS**
Indicated in capacity (μF) / voltage (V), unless otherwise noted. ±2% indication without voltage is 50V except electrolytic capacitor.
- VOLTAGE CURRENT**
□ DC voltage (V) at no input signal.
- SWITCHES** (Underline indicates switch position)
MAIN UNIT
S301 DOLBY NR ON-OFF
S302 DOLBY NR B-C
S303 MPX FILTER ON-OFF
SW UNIT
S901 OPEN/CLOSE
S902 COUNTER RESET
S903 COUNTER MODE
S904 TAPE RETURN
S905 METER RANGE
S906 MS (REW) ←
S907 STOP
S908 PLAY
S909 MS (FF) ←
S910 REC ←
S911 PAUSE ←
S912 REC MUTE ⊕
S913 MONITOR AUTO
TAPE SELECTOR UNIT
S2 TAPE SELECTOR METAL-C/O
S3 TAPE SELECTOR NORM
TIMER UNIT
S101 TIMER REC-OFF-PLAY
REC SW UNIT
S1 REC INH ON-OFF
MECHA UNIT
S11 DOOR OPEN-CLOSE
POWER SW UNIT
S1201 POWER ON-OFF
- OTHERS**
— PLAYBACK SIGNAL ROUTE
--- RECORDING SIGNAL ROUTE
⊙ Adjusting point
△ mark found on some component parts indicates the importance of the safety factor of the part. Therefore when replacing be sure to use parts of identical designation.
⊕ marked capacitors and resistors have parts numbers.
This is the basic schematic diagram, but the actual circuit may vary due to improvements in design.

A

B

C

D

6. P.C. BOARDS CONNECTION DIAGRAM

• View from component side

A

B

C

D

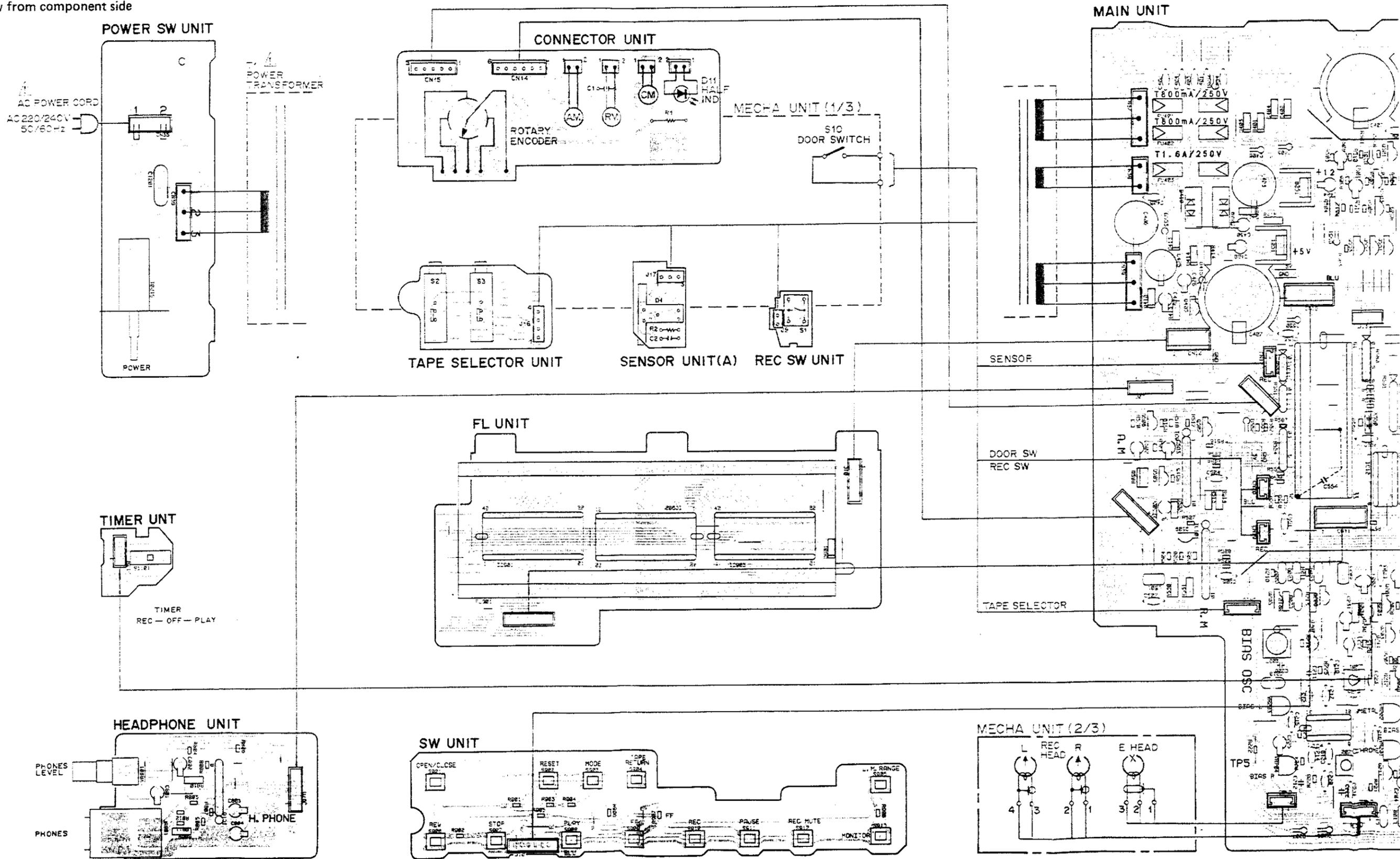

1

2

3

19

4

5

6

20

7

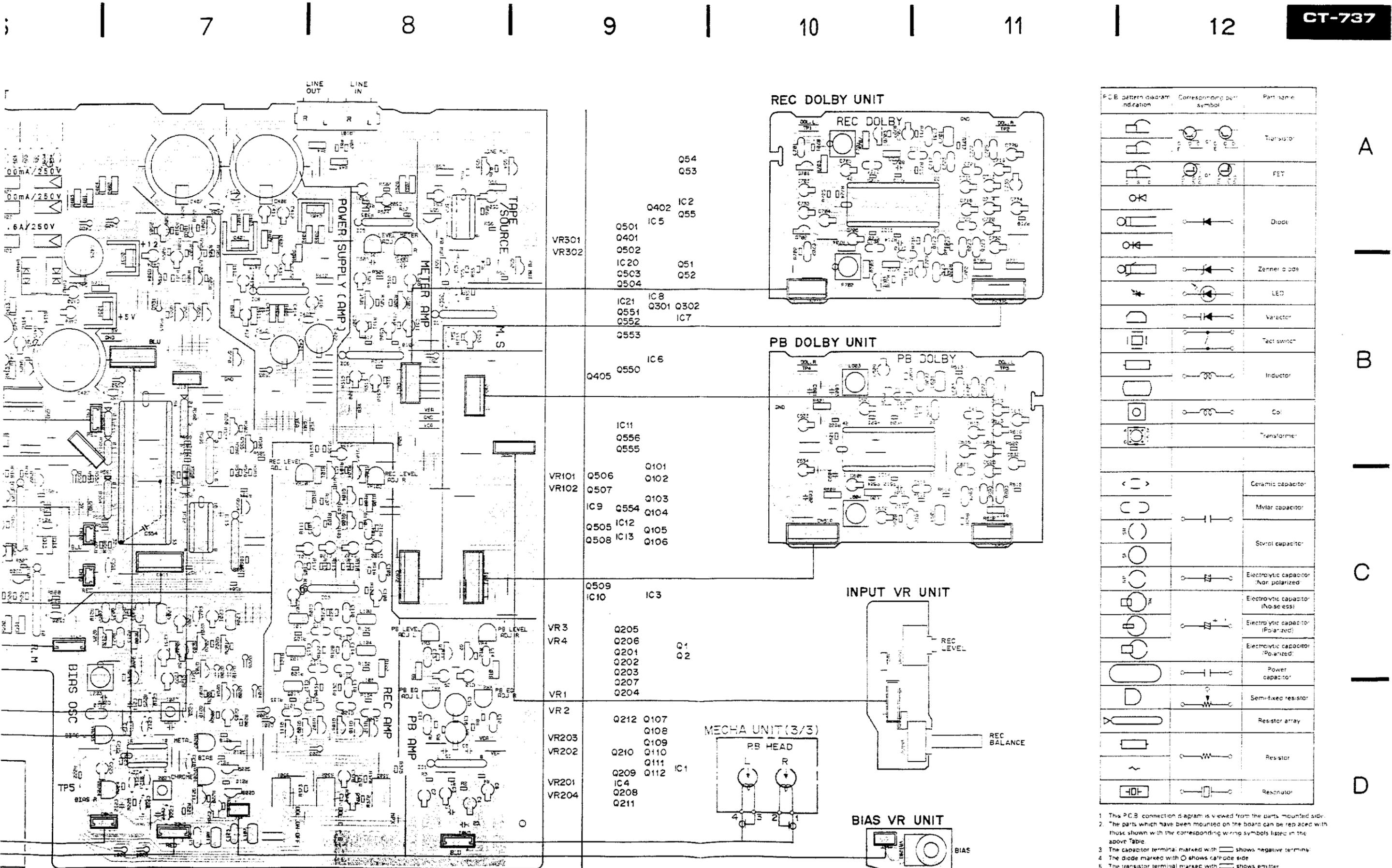

- Q54
- Q53
- Q402 IC2
- IC5 Q55
- Q501
- Q401
- Q502
- IC20
- Q503
- Q504
- Q51
- Q52
- IC21 IC8
- Q551 Q301 Q302
- Q552 IC7
- Q553
- Q405 Q550 IC6
- IC11
- Q556
- Q555
- Q506 Q101
- Q507 Q102
- IC9 Q554 Q103
- Q505 IC12 Q104
- Q508 IC13 Q105
- Q106
- Q509 IC3
- IC10
- Q205
- Q206
- Q201
- Q202
- Q203
- Q207
- Q204
- Q1
- Q2
- Q212 Q107
- Q108
- Q209 Q109
- Q210 Q110
- Q111
- Q112 IC1
- Q208
- Q211

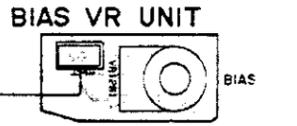
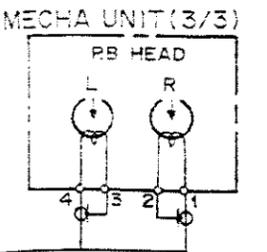
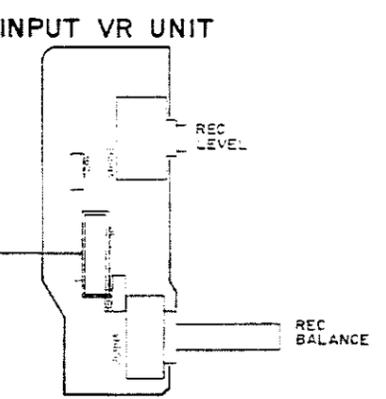
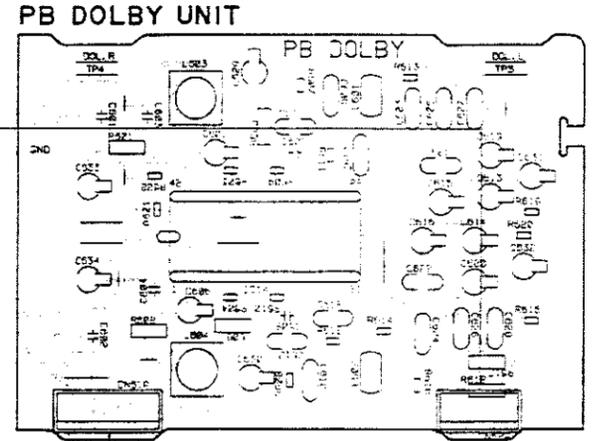
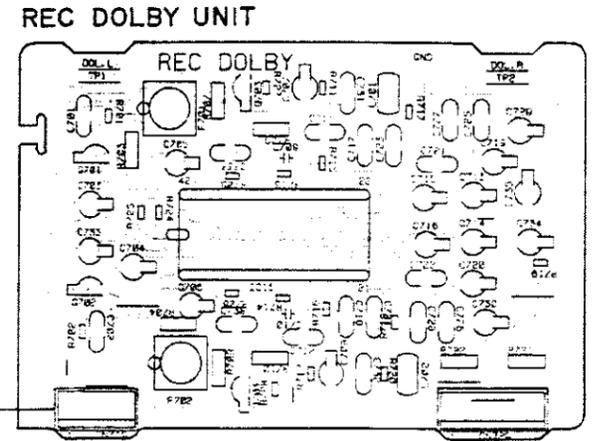

PCB pattern diagram indication	Corresponding part symbol	Part name
		Transistor
		FET
		Diode
		Zener diode
		LED
		Varactor
		Tact switch
		Inductor
		Coil
		Transformer
		Ceramic capacitor
		Mylar capacitor
		Styro capacitor
		Electrolytic capacitor (Non polarized)
		Electrolytic capacitor (Noiseless)
		Electrolytic capacitor (Polarized)
		Electrolytic capacitor (Polarized)
		Power capacitor
		Semi-fixed resistor
		Resistor array
		Resistor
		Resonator

1. This PCB connection diagram is viewed from the parts mounted side.
 2. The parts which have been mounted on the board can be replaced with those shown with the corresponding wiring symbols listed in the above table.
 3. The capacitor terminal marked with shows negative terminal.
 4. The diode marked with shows cathode side.
 5. The transistor terminal marked with shows emitter.

A
B
C
D

1 2 3 4 5 6 7

MAIN UNIT

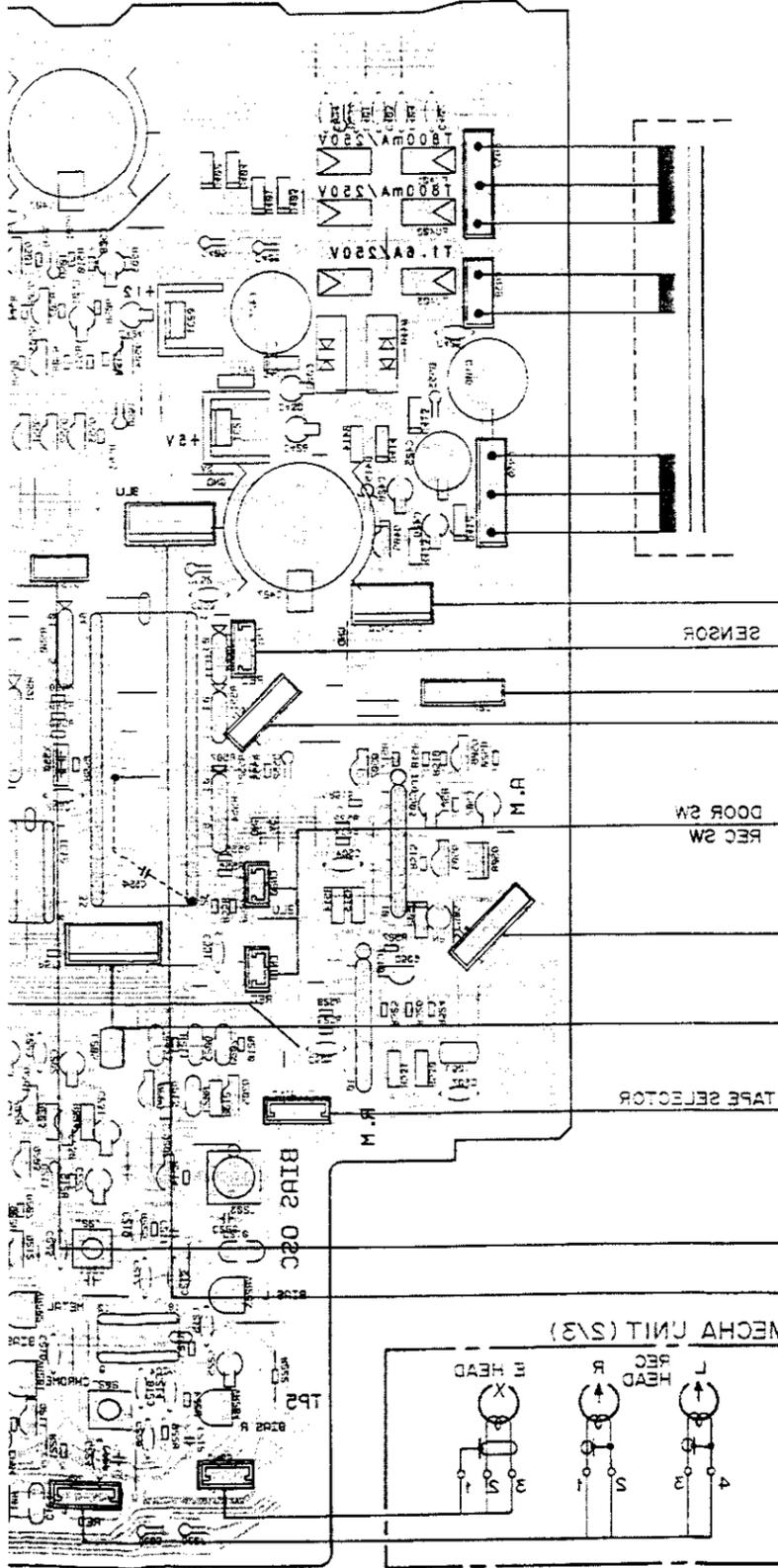

CONNECTOR UNIT

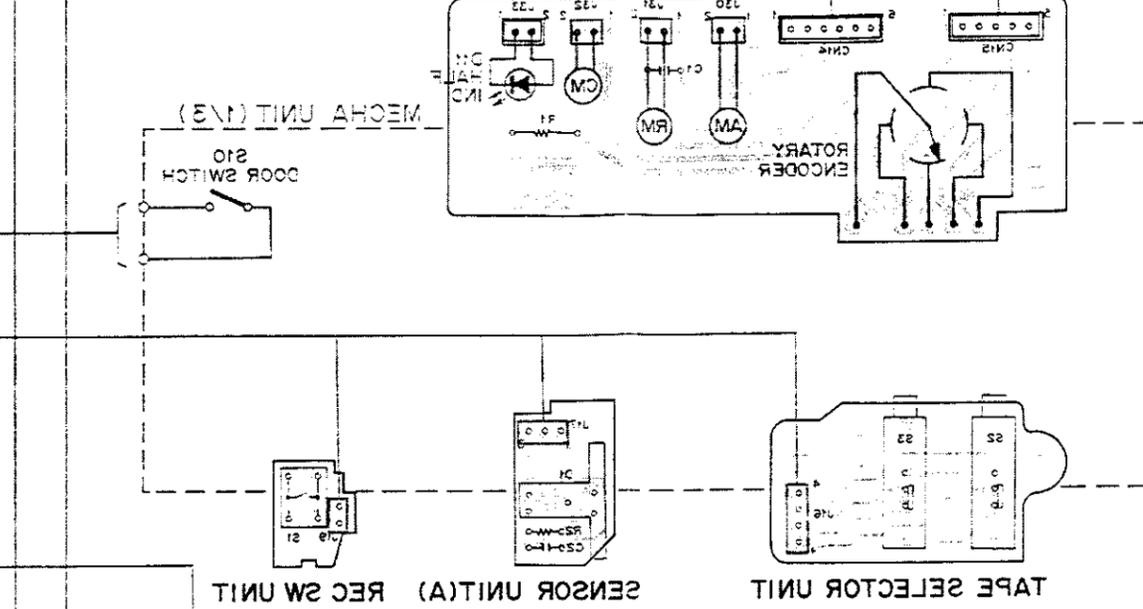

POWER SW UNIT

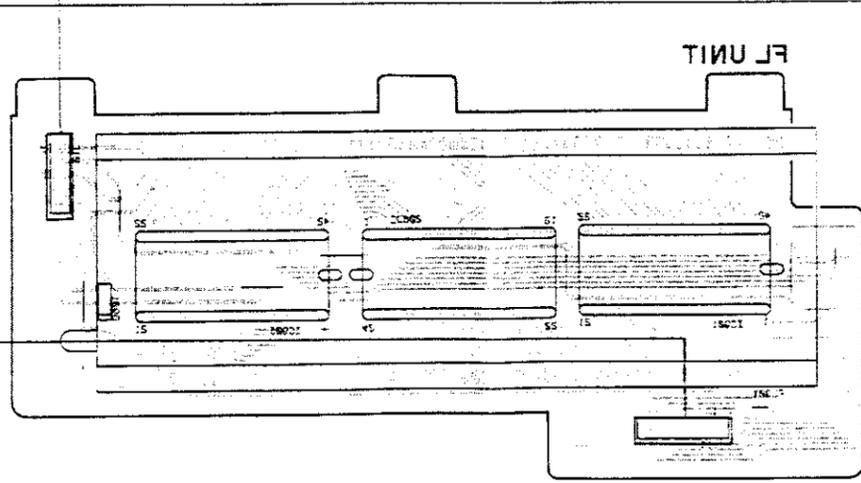
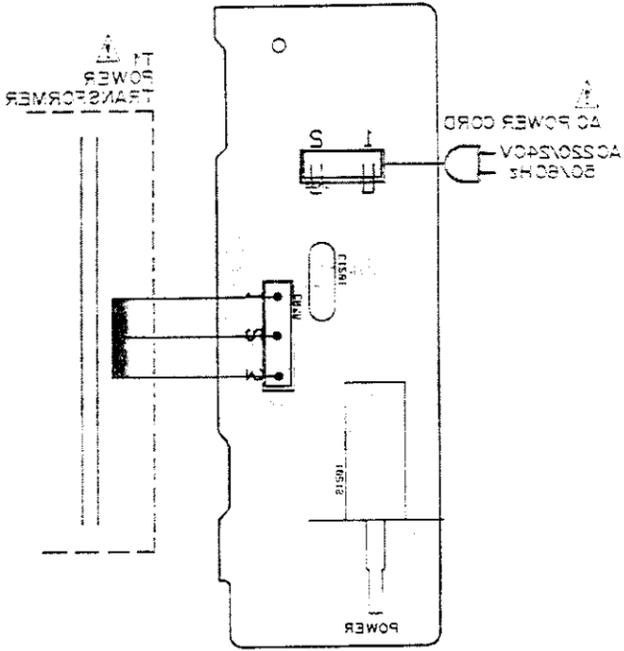

TIMER UNIT

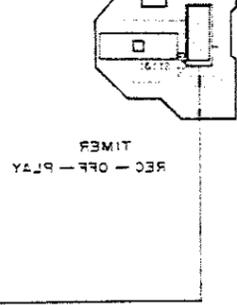

HEADPHONE UNIT

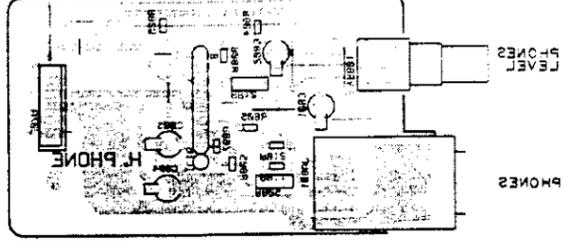

MECHA UNIT (S3)

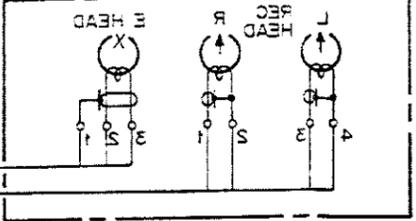

SW UNIT

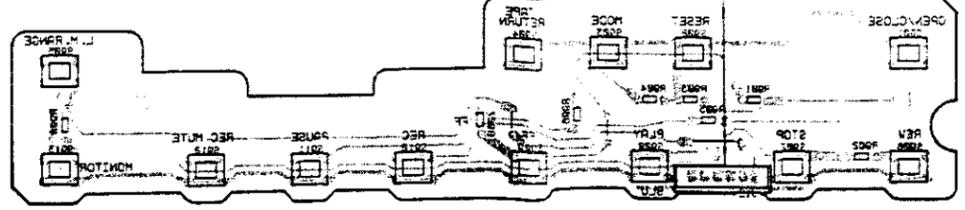

1 2 3 4 5 6 7

A

B

C

D

• View from soldering side

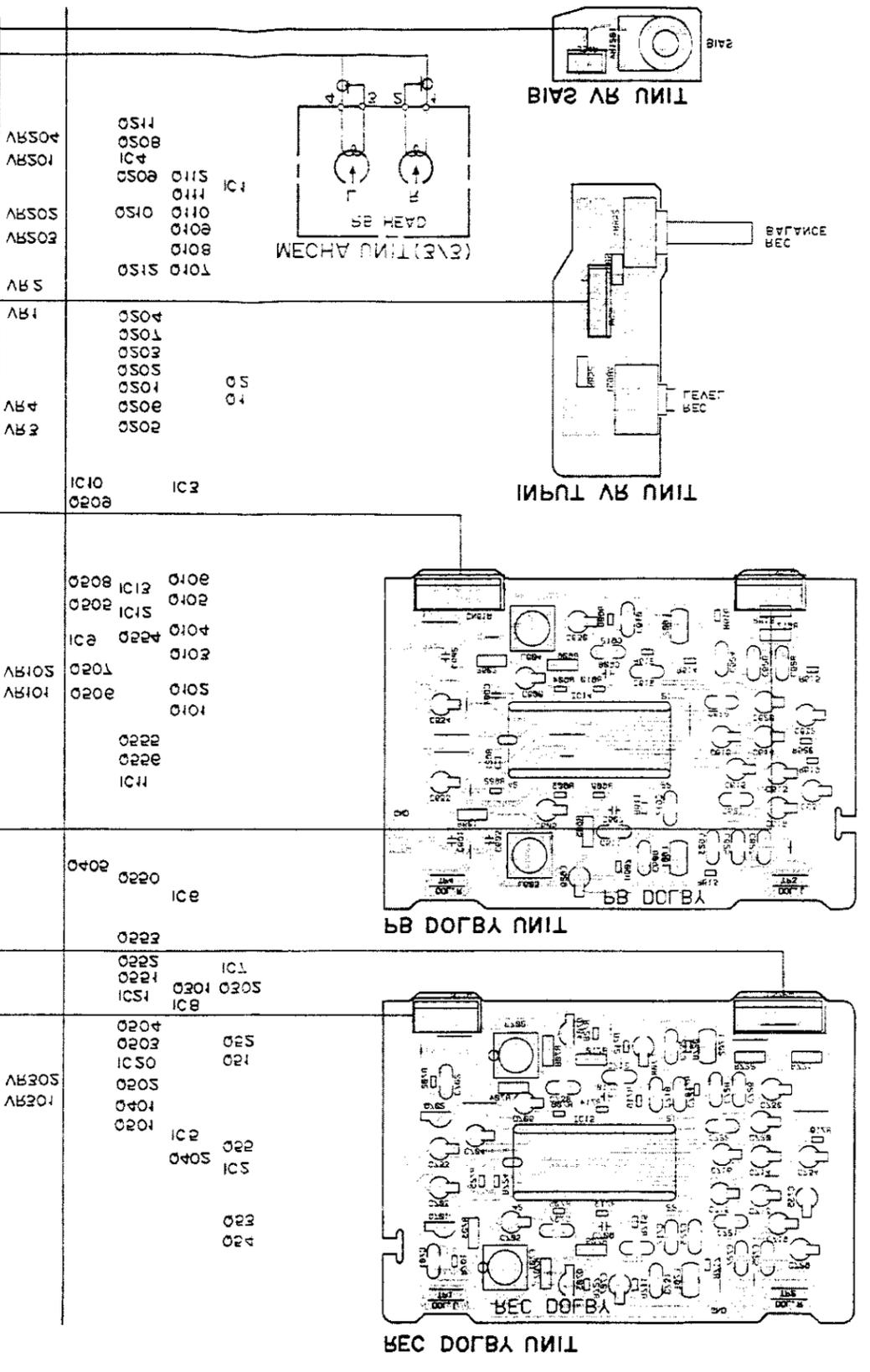
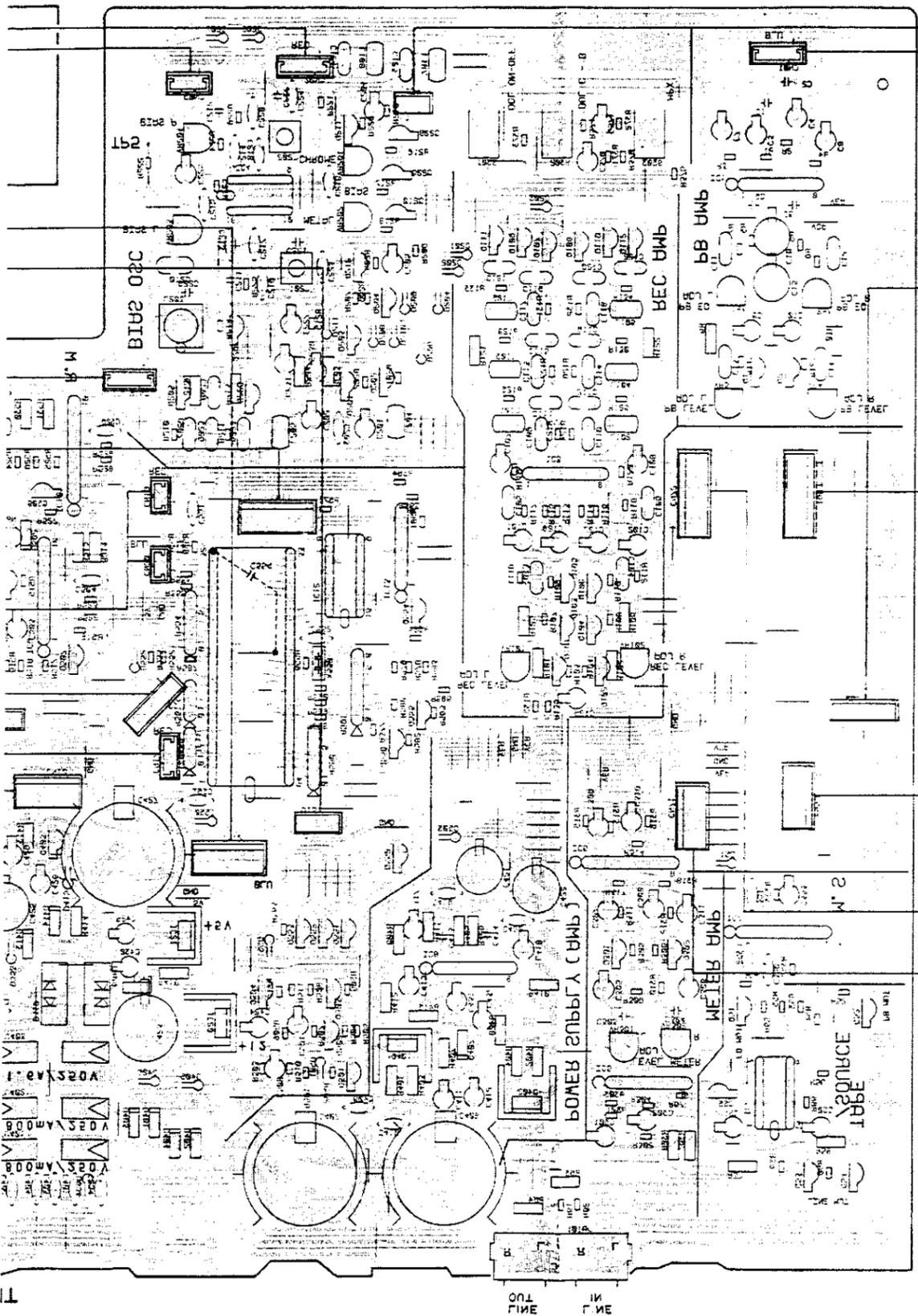

2 7 8 9 10 11 12 13 14 15 16 17 18 19 20 21 22 23

A B C D

7. ELECTRICAL PARTS LIST

NOTES :

- Parts without part number cannot be supplied.
- Parts marked by "Q" are not always kept in stock. Their delivery time may be longer than usual or they may be unavailable.
- The Δ mark found on some component parts indicates the importance of the safety factor of the part. Therefore, when replacing, be sure to use parts of identical designation.
- For your parts Stock Control, the fast moving items are indicated with the marks ★★ and ★.
- ★★ GENERALLY MOVES FASTER THAN ★.

This classification shall be adjusted by each distributor because it depends on model number, temperature, humidity, etc.

- When ordering resistors, first convert resistance values into code form as shown in the following examples.
- Ex.1 When there are 2 effective digits (any digit apart from 0), such as 560 ohm and 47k ohm (tolerance is shown by J=5%, and K=10%).

560 Ω	56×10 ¹	561	RD1/4PS	561J
47k Ω	47×10 ³	473	RD1/4PS	473J
0.5 Ω	0R5		RN2H	5K
1 Ω	010		RS1P	10K
- Ex.2 When there are 3 effective digits (such as in high precision metal film resistors).

5.62k Ω	562×10 ²	5621	RN1/4SR	5621F
---------	---------------------	------	-------	---------	-------

Miscellaneous Parts

P. C. BOARD ASSEMBLIES

Mark	Symbol & Description	Part No.
	Headphone unit	
	Input VR unit	
	Main unit	
	Timer unit	
	Power SW unit	
	FL unit	
	SW unit	
	PB Dolby unit	
	REC Dolby unit	
	Tape selector unit	
	Sensor unit (A)	
	REC SW unit	
	Connector unit	
	Bias VR unit	

Main unit

SEMICONDUCTORS

Mark	Symbol & Description	Part No.
★★	IC7	BA335
★★	IC9, IC10	BA6109
★★	IC6	BA6138
★★	IC1	M5220L
★★	IC13	M5233L
Δ★★	IC21	NJM78M05A
Δ★★	IC20	NJM78M12A
★★	IC11	PD4148B
★★	IC12	TC4050BP
★★	IC2	TC4066BP
★★	IC4	μ PC1297CA
★★	IC3, IC5, IC8	M5218L
★★	Q1, Q2, Q103-Q112	DTC1147S
★★	Q55, Q202, Q203, Q208-Q210	DTC124ES
★★	Q550-Q553	DTA114ES

OTHERS

Mark	Symbol & Description	Part No.
Δ★★	FU403 Fuse (1.6A)	REK-102
Δ★★	FU401, FU402 Fuse (800mA)	REK-099
★	T1 Power transformer	RTT1052
Δ	AC power cord	PDG1003 (RDG-027)
★	D11 Diode (LED)	SLF-401C
★★	Erase head	RPB1002
★★	Micro switch	RSF-031
★★	Rotary encoder	RSX-059
★★	Capstan motor assembly	RXM1016
★★	Reel motor assembly	RXM1018
★★	Power motor assembly	RXX1055
★★	Head base assembly	RXX1103
Δ	Strain relief	CM22B

Mark	Symbol & Description	Part No.
Δ★★	Q201, Q405	2SA1283
★★	Q204, Q212, Q501, Q504-Q506, Q554	2SA1309A
★★	Q508	2SA936
Δ★★	Q402	2SB950
★★	Q205, Q206	2SC3243
★★	Q211, Q301, Q302, Q502, Q503, Q507, Q509, Q555, Q556	2SC3311A
Δ★★	Q401	2SD1276
★★	Q51-Q54, Q101, Q102, Q207	2SD1302
Δ	D407	HZ5CLL
Δ	D415	MTZ13B
Δ	D412	RD2.7EB1
Δ	D409	1B2C1-LC2
Δ	D410	1B2Z1-LC2
Δ	D411, D413, D414, D502	1SR35-100A
★	D201-D211, D405, D406, D501, D550, D551, D552, D51	1SS254
Δ	D401-D404	10DF2FA9

SWITCHES

Mark	Symbol & Description	Part No.
★★	S301-S303	RSG1017

COILS

Mark	Symbol & Description	Part No.
	L204, L205 L201, L202 (85kHz) L203 Oscillator coil L107, L108 (2.2mH)	LRA121K RTD1020 RTD1021 RTF1017
	L101-L106 (5.6mH) L501 (0.5mH)	RTF1022 RTF1068

CAPACITORS

Mark	Symbol & Description	Part No.
	C219, C220 C505 C503 C353 C411, C4112, C424, C428, C431, C432	CCCSL101K500 CEANP4R7M35 CEASR22M50 CEASR47M50 CEA101M25
	C201, C202 C425 C309, C310 C406 C205, C225, C227, C230, C231, C415, C426, C429, C501, C502	CEAS221M16 CEAS102M25 CEAS2R2M50 CEAS222M25 CEAS330M35
	C423 C204, C305-C308, C508 C9, C10 C101, C102, C125, C301, C302, C417, C418	CEAS332M25 CEAS4R7M50 CEYANP100M25 CEYA010M50
	C3, C4, C51, C52, C107, C108, C370, C371 C7, C8, C15, C16, C126, C127, C421, C22 (100/10) C109, C110, C113, C114, C213, C214	CEYA100M50 RCH1020 CFTXA103J50
	C121, C122 C11, C12, C206, C215, C216 C13, C14 C207, C209 C105, C106	CFTXA222J50 CFTXA223J50 CFTXA273J50 CFTXA332J50 CFTXA334J50
	C103, C104 C115, C116, C119, C120 C208 C117, C118 C351, C352	CFTXA392J50 CFTXA562J50 CFTXA682J50 CFTXA822J50 CGCYX104K25
	C221, C222 C504, C506, C551-C553 C56, C217, C218, C223, C350, C401-C405, C409, C410, C410, C419, C420, C507	CKCYB561J500 CKCYF103Z50 CKCYF473Z50

Mark	Symbol & Description	Part No.
	C5, C6, C226, C413, C414 C211, C212, C303, C304 C123, C124 C210 C1, C2	CKPUYB101K50 CKPUYB821K50 CQMA162J50 CQPA012J100 CQSF181J50
	C554 C427 (6800/25) C407, C408 (2200/25)	CKDYF473Z50 RCH1010 RCH1013

RESISTORS

Mark	Symbol & Description	Part No.
	VR1, VR2, VR201, V203, V204 (Semi-fixed 10k) VR3, VR4, VR101, VR102, VR301, VR302 (Semi-fixed 22k) VR202 (Semi-fixed 47k)	VRTB6VS103 VRTB6VS223 VRTB6VS473
	R550, R551 (22K x 4) R554, R560 (10K x 7) R591 (11K) R577-R581 R513	RCX1009 RCX1010 RCX1020 RN/P□□□□□ RS1LMF010J
	R212, R213 R222 R203, R401, R402, R408, R414, R415 R9, R10, R57, R58, R63, R64, R101, R102, R105, R106, R121, R122, R307, R308, R405, R406, R407, R409-R413, R403, R404	RD¼PMF8R2J RD¼LF010J RD¼PMF□□□□ RD¼PM□□□□J
	Other resistors	RD¼PM□□□□J

OTHERS

Mark	Symbol & Description	Part No.
	Pin jack 4P (INPUT, OUTPUT) X550 Ceramic resonator (4.19MHz)	RKB1003 VSS1014

Headphone Unit

SEMICONDUCTOR

Mark	Symbol & Description	Part No.
★★	IC16 OP-AMP IC	M5218L

CAPACITORS

Mark	Symbol & Description	Part No.
	C801, C802 C803, C804 (100/10)	CEYA010M50 RCH1020

RESISTORS

Mark	Symbol & Description	Part No.
	VR801 Variable resistor (20k-B) (PHONES LEVEL)	RCV1016
	R809, R810 Other resistors	RD¼PM470J RD¼PM□□□□J

OTHERS

Mark	Symbol & Description	Part No.
	Jack (PHONES)	RKN1002

BIAS VR Unit

RESISTORS

Mark	Symbol & Description	Part No.
	VR1201 Variable resistor (5K-B, BIAS)	RCV1007

INPUT VR Unit

RESISTORS

Mark	Symbol & Description	Part No.
	VR852 Variable resistor (20k-A)	RCV1005
	VR851 Variable resistor (50k-A)	RCV1021
	R851, R852	RD¼PM333J

Timer Unit

SWITCH

Mark	Symbol & Description	Part No.
	S1101 Slide SW (TIMER REC-OFF-PLAY)	RSH1014

Power SW Unit

SWITCH

Mark	Symbol & Description	Part No.
⚡★★	S1201 (POWER)	RSA-063

CAPACITOR

Mark	Symbol & Description	Part No.
⚡	C1201 (0.01 μF/AC400V)	VCG-044

FL Unit

SEMICONDUCTORS

Mark	Symbol & Description	Part No.
★★	IC901-IC903	LC7570
*	D901	1SS254

OTHER

Mark	Symbol & Description	Part No.
	FL tube	RAW1018

SW Unit

SWITCHES

Mark	Symbol & Description	Part No.
★★	S901-S913 Tact switch (■, □, ●, ▲, ■, TAPE RETURN, ▷, COUNTER, RESET, COUNTER MODE, TAPE CAPACITY, METER RANGE, MONITOR, ○)	RSG-155

RESISTORS

Mark	Symbol & Description	Part No.
	All resistors	RD¼DPM□□□□

PB DOLBY Unit

SEMICONDUCTOR

Mark	Symbol & Description	Part No.
★★	IC14 DOLBY-B, C IC	CX20187

COILS

Mark	Symbol & Description	Part No.
	L603, L604 Trap coil L601, L602 Coil (19mH)	RTF-162 RTF1005

CAPACITORS

Mark	Symbol & Description	Part No.
	C631, C632 C615, C616 C619, C620 C613, C614 C605, C606	CEASR10M50 CEASR15M50 CEASR22M50 CEASR47M50 CEYA010M50
	C629, C630 C633, C634 C627, C628 C617, C618 C609, C610	CEYA100M50 CEZA101M10 CFTXA103J50 CFTXA153J50 CFTXA332J50
	C611, C612 C623, C624 C625, C626 C621, C622 C601, C602	CFTXA472J50 CFTXA473J50 CFTXA682J50 CFTXA683J50 CKPUYB101K50
	C607, C608	CKPUYB681K50

RESISTORS

Mark	Symbol & Description	Part No.
	R601, R602, R605, R606, R617, R618 Other resistors	RD¼PM□□□□J RD¼PM□□□□J

REC DOLBY Unit

SEMICONDUCTORS

Mark	Symbol & Description	Part No.
★★	IC15	CX20187
★★	Q701-Q704	DTC114ES

COILS, FILTER

Mark	Symbol & Description	Part No.
	L701, L702 Coil (19mH)	RTF1005
	F701, F702 MPX Filter	RTF-154

CAPACITORS

Mark	Symbol & Description	Part No.
C715, C716	CEASR15M50	
C719, C720	CEASR22M50	
C713, C714	CEASR47M50	
C733	CEAS100M50	
C703, C704	CEYA010M50	
C705-C708	CEYA100M50	
C729, C730	CEYA4R7M50	
C734, C735	CEZA101M10	
C727, C72E	CFTXA103J50	
C701, C702	CFTXA122J50	
C717, C71E	CFTXA153J50	
C731, C732	CFTXA332J50	
C737, C73E	CFTXA392J50	
C711, C712	CFTXA472J50	
C723, C724	CFTXA473J50	
C725, C72E	CFTXA682J50	
C721, C722	CFTXA683J50	
C709, C710	CKPUYB681K50	

RESISTORS

Mark	Symbol & Description	Part No.
R721, R722, R703, R704,	RD $\frac{1}{4}$ JPM□□□J	
R707-R710	RD $\frac{1}{4}$ PM□□□J	
Other resistors	RD $\frac{1}{4}$ PM□□□J	

Tape Selector Unit

SWITCHES

Mark	Symbol & Description	Part No.
★★	S2, S3 Slide switch (NORMAL CrO ₂ , METAL)	RSH-070

Sensor Unit (A)

SEMICONDUCTOR

Mark	Symbol & Description	Part No.
*	D1 Photo interrupter	GP1A51HR

CAPACITOR

Mark	Symbol & Description	Part No.
C2		CKPUYY103N16

REC SW Unit

SWITCH

Mark	Symbol & Description	Part No.
★★	S1 Tact switch	RSG-143

Connector Unit

CAPACITOR

Mark	Symbol & Description	Part No.
C1		CKCYF473Z50

RESISTOR

Mark	Symbol & Description	Part No.
R1		RD $\frac{1}{4}$ PM681J

8. ADJUSTMENT

8-1. MECHANISM RELATED ADJUSTMENT

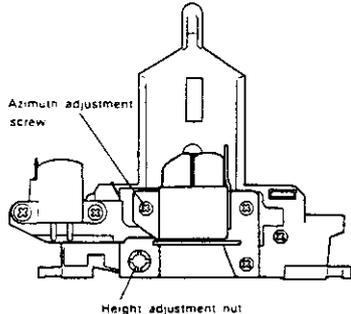
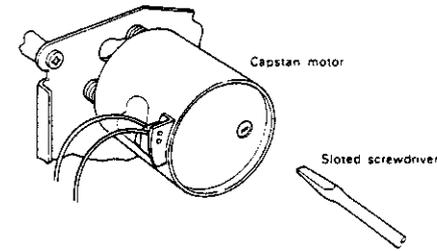
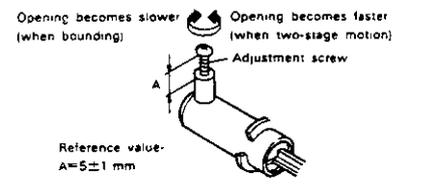
1. Azimuth adjustment				2. Tape Speed Adjustment		
No.	Mode	Adjustment Location	Specifications	Mode	Adjustment Location	Specifications
	PLAY	Azimuth adjustment screw (Refer to Fig. 1.)	Playback test tape STD-33: B and adjust so that the 10 kHz output level is maximum and also so that there is no phase difference between L-ch and R-ch.	PLAY	Capstan motor adjustment hole (Refer to Fig. 2.)	Adjust so that the playback frequency is 3015±5 Hz at the beginning of winding of test tape STD-301.
	PLAY			PLAY		Playback test tape STD-301 again and confirm that the above specifications are satisfied.
 <p style="text-align: center;">Fig. 1.</p>						
 <p style="text-align: center;">Fig. 2.</p>						
3. Adjustment of Air Damper						
Adjustment Location				Specifications		
Cylinder adjustment screw (Refer to Fig. 3.)				Make sure that the door opens smoothly, there is no two-stage motion, and that there is no bounding when it opens completely. (Perform with no cassette half inserted.)		
 <p style="text-align: center;">Fig. 3.</p>						

RECORDING SECTION

1. Bias oscillation frequency adjustment

* Adjust the bias oscillator with checks set to recording mode simultaneously. (Double R/P only)

NO	Mode	Input signal & test tape	Adjustment location	Measuring location	Adjustment value	Remarks
1.	REC	Load the STD-610 test tape with no input signal.	DECK I L203	TP.11	85kHz±300Hz	

2. Recording Bias Adjustment

2-1. Overbias Adjustment

No	Mode	Input signal & test tape	Adjustment location	Measuring location	Adjustment value	Remarks
1	REC/ PAUSE	Apply a 6.3kHz/10dBv (-10VU meter reading) signal to the Line input terminals and insert STD-608A.	—	LINE OUT L, R terminals	—	
2	REC -PLAY	Record and play back the 6.3kHz signal at -10dB input level.	NOR VR203 (L) VR204 (R)		NOR 3.0dB overbias	Turn control clockwise past the peak to assure proper overbias value
3		Record the 6.3kHz/-10dBv signal on STD-620 and play back.	CrO ₂ VR201 (L/R)		Cr ₂ 2.5dB overbias	
4		Record the 6.3kHz/-10dB signal on STD-610 and play back.	METAL VR202 (L/R)		METAL 1.0dB overbias	

2-2. Frequency Response Adjustment

No	Mode	Input signal & test tape	Adjustment location	Measuring location	Adjustment value	Remarks
1	REC/ PAUSE	Apply a 315Hz/-20dBv signal to the Line input terminals and insert STD-608A.	—	LINE OUT L, R terminals	—	
2	REC -PLAY	Record and play back the 315Hz signal and a 10kHz signal at -20dBv input level.	NOR VR203 (L) VR204 (R)		Record and play back repeatedly, comparing the 315Hz and 10kHz playback levels, and adjust to -0.5±0.5dB.	
3		Record the 10kHz/315Hz, -20dBv signal on STD-620 and play back.	CrO ₂ VR201 (L/R)		+0.5±1.0dB	
4		Record the 10kHz/315Hz, -20dBv signal on STD-610 and play back.	METAL VR202 (L/R)		+0.5±1.0dB	
5	Check distortion value after adjustment is completed and confirm that there is no underbias.					

3. Recording Level Adjustment

NO	Mode	Input signal & test tape	Adjustment location	Measuring location	Adjustment value	Remarks
1	STOP	Set the TAPE SELECTOR switch to the NORM position.				
2	REC PAUSE	Apply a 315 Hz/0 dBv signal to the Line Input terminals.	REC Level control	TP.1 (Lch) TP.2 (Rch)		
3	Set the DOLBY NR switch to the ON position. (DOLBY B)					
4	REC/ PLAY	Record the above signal onto the STD-608A test tape, and playback.	Deck I VR101 (Lch) VR102 (Rch)	TP.3 (Lch) TP.4 (Rch)	-15.2 dBv	
5	STOP	Set the TAPE SELECTOR switch to the CrO ₂ position.				
6	REC/ PLAY	Record the above signal onto the STD-620 test tape, and playback.	Confirm	TP.3 (Lch) TP.4 (Rch)	-15.2 dBv ± 1.5 dB	
7	STOP	Set the TAPE SELECTOR switch to the METAL position.				
8	REC/ PLAY	Record the above signal onto the STD-610 test tape, and playback.	Check	TP.3 (Lch) TP.4 (Rch)	-15.2 dBv ± 1.5 dB	

4. Recording and Playback Frequency Response Check

NO	Mode	Input signal & test tape	Adjustment location	Measuring location	Adjustment value	Remarks
1.	STOP	Set the TAPE SELECTOR switch to the NORM position.				
2	REC/ PLAY	STD-608A (NORM) NR:OFF/ON (TYPE B, C)	Check	LINE OUT		The allowable zone shown in Fig. 8-5 is to be satisfied.
3	STOP	Set the TAPE SELECTOR switch to the CrO ₂ position.				
4	REC/ PLAY	STD-620(CrO ₂) NR:OFF/ON (TYPE B, C)	Check	LINE OUT		The allowable zone shown in Fig. 8-6 is to be satisfied.
5	STOP	Set the TAPE SELECTOR switch to the METAL position.				
6	REC/ PLAY	STD-610(METAL) NR:OFF/ON (TYPE B, C)	Check	LINE OUT		The allowable zone shown in Fig. 8-7 is to be satisfied.

5. Level Meter Check

NO	Mode	Input signal & test tape	Adjustment location	Measuring location	Adjustment value	Remarks
1.	REC PAUSE Meter: Expand Mode	Apply a 315 Hz/-10 dBv (316 mV) signal to the Line Input terminals.	VR301 (Lch) VR302 (Rch)	TP.1 (Lch) TP.2 (Rch)		Check that the level meters "0 dB" light up within -15.2dBv ± 0.5dB of the signal output level.

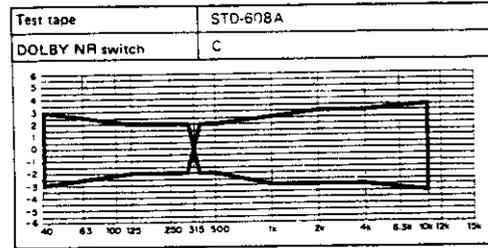
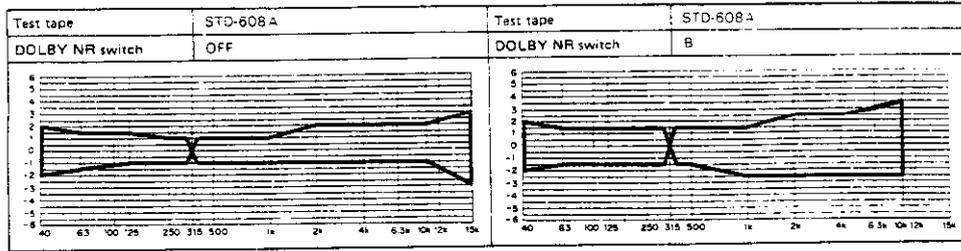

Fig.8-5 Recording/Playback frequency-response allowance range (NORM)

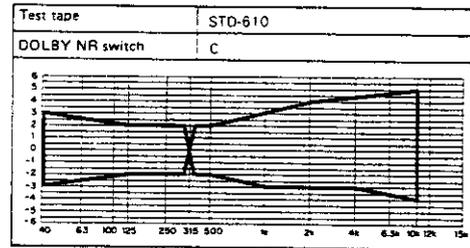
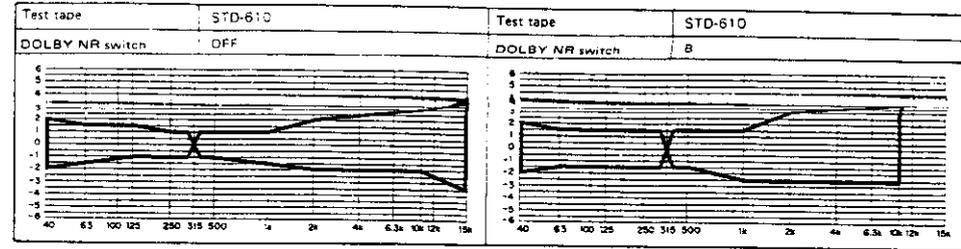

Fig.8-7 Recording/Playback frequency-response allowance range (METAL)

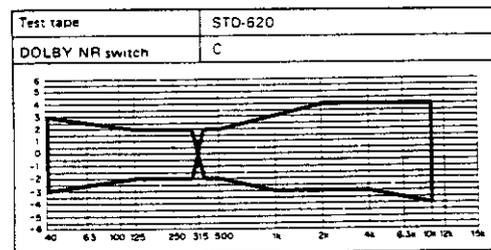
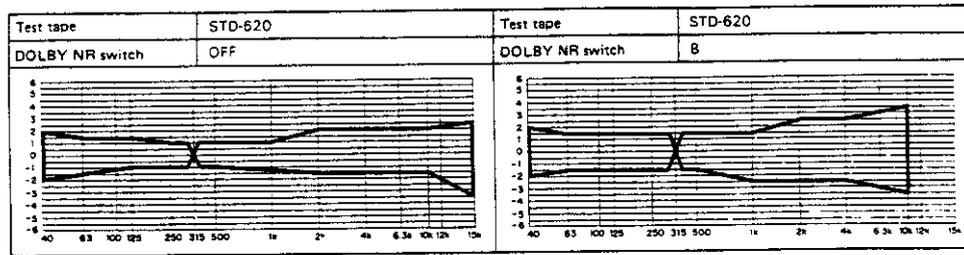

Fig.8-6 Recording/Playback frequency-response allowance range (CrO₂)

9. FOR HB AND CT-737-S/HEM TYPES

CONTRAST OF MISCELLANEOUS PARTS

NOTES:

- Parts without part number cannot be supplied.
- The Δ mark found on some component parts indicates the importance of the safety factor of the part. Therefore, when replacing, be sure to use parts of identical designation.
- For your parts Stock Control, the fast moving items are indicated with the marks $\star\star$ and \star .
 $\star\star$ GENERALLY MOVES FASTER THAN \star .
- This classification shall be adjusted by each distributor because it depends on model number, temperature, humidity, etc.
- Parts marked by "O" are not always kept in stock. Their delivery time may be longer than usual or they may be unavailable.

The CT-737-S/HEM and HB types are the same as the CT-737/HEM type with the exception of the following sections.

Mark	Symbol & Description	Part No.			Remarks
		CT-737 HEM type	CT-737 HB type	CT-737-S HEM type	
	Knob (PHONES LEVEL)	PAC1208	PAC1208	PAC1271	
	Knob A (TIMER)	RAC-668	RAC-668	RAC1219	
	Button (POWER)	RAC1203	RAC1203	RAC1292	
	Button (DOLBY, MPX)	RAC1204	RAC1204	RAC1293	
	Button (CONTROL)	RAC1206	RAC1206	RAC1294	
	VR Knob (B)	RAC1262	RAC1262	RAC1263	
	Button (COUNTER)	RAC1232	RAC1232	RAC1289	
	Side panel (L)	RAH1200	RAH1200	RAH1321	
	Side panel (R)	RAH1201	RAH1201	RAH1322	
	Door panel	RAH1314	RAH1314	RAH1315	
	Under escutcheon	RAP1003	RAP1003	RAP1006	
	Packing case	RHG1076	RHG1076	RHG1077	
	Button holder	RNK1301	RNK1301	RNK1361	
	VR knob assembly (A)	RXA1158	RXA1158	RXA1214	
	Bonnet	RXX1092	RXX1092	RXX1093	
	Front panel assembly	RXX1111	RXX1111	RXX1112	
	Door assembly	RXX1113	RXX1113	RXX1114	
	AC Power cord	PDG1003	RDG-032	PDG1003	
	Operating instructions (English, French, German, Italian, Dutch, Spanish, Portuguese, Swedish)	RRE1015	
	Operating instructions (English)	RRB1016	
	Operating instructions (German)	RRD1038	