

Service Manual

CASSETTE TAPE DECK

CT-F500
CT-F505

 **PIONEER®**

This service manual is applicable to the CT-F500/KC,KU,CT-F505/KU

Type	Voltage	Remarks
KU	120V only	U.S.A. model
KC	120V only	Canada model

CONTENTS

1. SPECIFICATIONS	3	10.3 Playback Level Adjustment	24
2. FRONT PANEL FACILITIES	4	10.4 Level Meters OdB Adjustment	24
3. DISASSEMBLY		10.5 Rough Adjustment of Recording Current	24
3.1 Front Panel, Panel Stay and Mechanism	6	10.6 Rough Adjustment of Recording Bias	25
3.2 Pinch Roller	7	10.7 Record and Playback Frequency Adjustment	26
3.3 Take-up Reel Base	7	10.8 Recording Level Adjustment	27
3.4 Flywheel, Belt and Motor	8	10.9 Dolby Circuit Adjustment	27
3.5 Supply Reel Base	9	11. SCHEMATIC DIAGRAMS, P.C. BOARD PATTERNS AND PARTS LIST	
4. PARTS LOCATION	10	11.1 Miscellaneous Parts List	28
5. BLOCK DIAGRAM	12	11.2 Connection Diagram	29
6. LEVEL DIAGRAM	13	11.3 Schematic Diagram	31
7. CIRCUIT DESCRIPTIONS		11.4 P.C. Board Connection Diagram	33
7.1 Recording and Playback Circuit	14	11.5 Mother Assembly	36
7.2 Muting Circuit	16	11.6 Dolby Assembly	39
7.3 Muting Release	16	11.7 Indicator Assembly	40
7.4 Oscillator Circuit	17	11.8 Terminal Board Assembly	40
7.5 Power Supply Circuit	17	12. EXPLODED VIEW	
8. MECHANICAL DESCRIPTIONS	18	12.1 Bonnet and Bottom Cover	41
9. MECHANICAL ADJUSTMENTS		12.2 Panel	42
9.1 Tape Speed Adjustment	20	12.3 Chassis	43
9.2 Motor Switch Adjustment	21	12.4 Door	44
9.3 F.F. (REW) Switch Adjustment	21	12.5 Mechanism-1	45
9.4 Pinch Roller Pressure Adjustment	21	12.6 Mechanism-2	47
9.5 Reel Base Torque Adjustment	22	12.7 Pulley and Idler	49
9.6 Play Switch Adjustment	22	12.8 Button	50
9.7 Leaf Switch Timing Adjustment	22	12.9 Head Base	50
9.8 Pause Timing Adjustment	22	12.10 Reel Base	51
10. ELECTRICAL ADJUSTMENTS	23	13. PACKING	52
10.1 Head Azimuth Adjustment	24		
10.2 Playback Equalizer Check	24		

1. SPECIFICATIONS

Systems	Compact cassette, 2-channel stereo
Motor	Electronically-controlled DC motor x 1
Heads	"Hard Permalloy" recording/playback head x 1 Ferrite erasing head x 1
Fast Winding Time	Approximately 90 seconds (C-60 tape)
Wow and Flutter	No more than 0.05% (WRMS)
Frequency Response	Standard, LH tapes; 30 to 14,000Hz (40 to 13,000Hz \pm 3dB) Ferrichrome tape: 30 to 16,000Hz (40 to 15,000Hz \pm 3dB) Chromium dioxide tape: 30 to 16,000Hz (40 to 15,000Hz \pm 3dB)
Signal-to-Noise Ratio	Dolby NR OFF: More than 54dB Dolby NR ON: More than 64dB (over 5kHz, standard, LH tapes) When chromium dioxide tape is used, signal-to-noise ratio is further improved by 4.5dB over 5kHz
Harmonic Distortion	No more than 1.5% (0dB)
Inputs (Sensitivity/Maximum allowable input/Impedance)	MIC (L, R); 0.3mV/110mV/10kilohms, 6mm diam. jacks (Reference MIC impedance; 250 ohms to 10kilohms) LINE (2-channel stereo); 65mV/14V/100kilohms, pin jacks
Outputs (Reference level/Load impedance)	LINE (2-channel stereo); 450mV/50kilohms, pin jacks Headphones x 1; 60mV/8 ohms, 6mm diam. jack
Semiconductors	
Amplifier Section	Transistors x 20, Diodes x 11, ICs x 2
Motor control section	IC ₃ x 1, Diodes x 1
Subfunctions	<ul style="list-style-type: none"> • Dolby system (ON-OFF) with LED indicator lamp • Tape Selector (STD/FeCr/CrO₂)
Power Requirements	AC 120V, 60Hz
Power Consumption	13 watts
Dimensions	380(W) x 140(H) x 261(D) mm Max. 15 x 5-1/2 x 10-5/16 in
Weight	5kg (11lb)
Furnished parts	Stereo connecting cord with pin plugs x 2 Head cleaning kit x 1 Operating instruction x 1

NOTE:

Specifications and the design subject to possible modification without notice due to improvements.

NOTE:

1. Reference Tapes : Standard & LH; DIN 45513/BLATT6 or equiv.
: CrO₂ ; DIN 45513/BLATT7 (CrO₂) or equiv.
2. Reference Recording Level: Meter 0dB indicating level (160 nwb/m magnetic level = Philips cassette reference level)
3. Reference Signal: 333Hz
4. Wow & Flutter: • JIS [3kHz, with acoustic compensation (weighted), rms value]
5. Frequency Response: • Measured at -20dB level, DOLBY NR OFF, level deviation is \pm 6dB without indication
6. Signal-to-Noise Ratio: • Measured at +4dB level (250nwb/m magnetic level = DIN 45513 specified reference level), IEC A curve with acoustic compensation (weighted)
7. Sensitivity: Input level (mV) required for reference recording level with input (REC) controls set to maximum.
8. Maximum Allowable Input: While decreasing settings of input (REC) level controls and increasing level at input jacks, this is the maximum input level (mV) at the point where recording amplifier output waveform becomes clipped.
9. Reference Output Level: Playback output level when meter indicates 0dB.

2. FRONT PANEL FACILITIES

POWER SWITCH

The power comes on when the POWER switch is depressed. The level meters will then light up. To turn off the power, release the switch by depressing it again.

CASSETTE HOLDER

The cassette tape is loaded into this holder. When the STOP/EJECT lever is depressed, the holder will jump forward. To close it, push the top part of the holder back into position until it is locked.

COUNTER RESET BUTTON

Depress this button to reset the tape counter display to "000."

TAPE COUNTER

This indicates the position of the tape run.

RECORD INDICATOR

This light comes on when the play (▶) and REC levers are depressed together to indicate that the cassette deck is now set to the recording mode.

DOLBY NR INDICATOR

This light comes on when the DOLBY NR switch is set to ON to indicate that the cassette deck is now set up for Dolby recording or Dolby playback.

INPUT LEVEL CONTROLS

Use these controls to adjust the input signal from the MIC jacks and the rear panel INPUT jacks. Turning them to the right increases the signal level. They are coupled to the left and right channels when rotated, but you can also use them to adjust the right channel and left channel independently by rotating the appropriate control and holding the other in position.

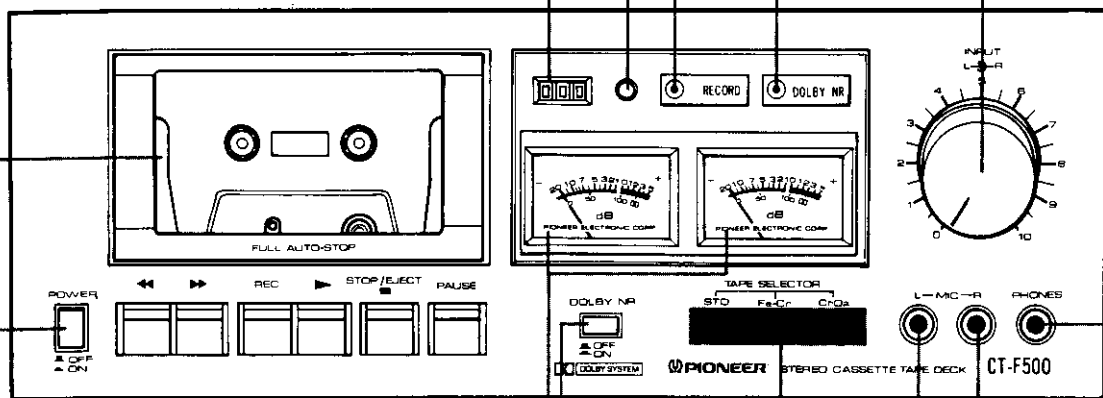

LEVEL METERS

These indicate the input level during recording and the output level during playback.

DOLBY NR SWITCH

Push this button to ON for recording with the built-in Dolby noise reduction system and for the playback of tapes which have been Dolby-recorded.

TAPE SWITCH

Push this button according to the tape to be used.

STD: For ordinary tapes and low-noise/high-output tapes.

Fe-Cr: For ferrichrome tapes.

CrO₂: For chrome tapes.

NOTE:

Be sure to use a chrome tape employing detection holes (see page 7).

MIC JACKS

These are the input jacks for microphone recording. Plug the left channel microphone into L and the right channel microphone into R.

PHONES JACK

This is the output jack for stereo headphones. Plug your headphones into this jack when you want to monitor the quality of a recording or when you want to listen to a tape privately.

NOTE:

You can damage a microphone if you plug it into the PHONES jack by mistake.

OPERATING LEVERS**FAST FORWARD LEVER (▶▶)**

Depress this lever to send the tape forward at top speed (the tape will travel from left to right).

REWIND LEVER (◀◀)

Depress this lever to rewind the tape (the tape will travel from right to left at high speed).

REC LEVER

To record, depress this lever and the play lever together. This lever will not work when a cassette is not loaded or when the erasure prevention tabs of a loaded cassette have been broken off.

PLAY LEVER (▶)

Depress this lever when playing back a tape. Depress it together with the REC lever for recording (the tape will travel from left to right).

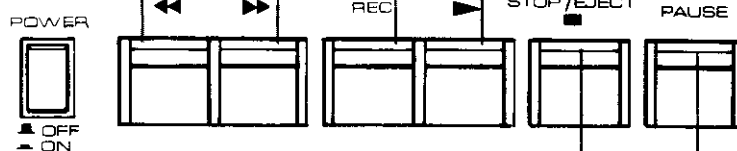
**STOP/EJECT LEVER**

Depress this lever to stop the tape. The operating levers in use will be released and the tape will stop. Depress this lever again after the tape has stopped in order to make the cassette holder spring forward.

PAUSE LEVER

Depress this lever to stop the tape temporarily during recording or playback. When it is released, the tape will continue to travel as before.

NOTES:

1. Apart from the play and REC levers, do not depress any of the levers simultaneously.
2. The operating levers will not return to their original positions even when the power is switched OFF.

PRECAUTIONS**HANDLING THE POWER CORD**

- Do not handle the power cord with wet hands. This is extremely dangerous since you may get an electric shock.
- Always take hold of the plug to unplug it from the power outlet -- do not unplug it by pulling on the cord. The cord may be damaged if you keep pulling on it.

PRECAUTIONS FOR USE

- Under no circumstances should the bonnet be removed, and the internal parts touched or modified in any way. Pioneer will not be held responsible in the event of a deterioration in performance or a breakdown if the cassette deck is modified in any way.
- Do not bring screwdrivers and other metal objects or magnets near the heads since you may damage and magnetize them.

KEEP THE HEAD SECTION CLEAN

The heads, capstan and pinch roller get dirty very easily since they come in contact with the tape. For further details on cleaning the head section, refer to page 8 and the section on 'Maintenance'.

NOTES:

- Do not force any of the switches, levers or knobs.
- Take care when operating the controls and always set them to their specified positions.

3. DISASSEMBLY

3.1 FRONT PANEL, PANEL-STAY AND MECHANISM

1. Pull off the two level control knobs.
2. Remove the front panel mounting screws.
3. Remove the level control mounting nuts and washers.
4. Remove the sub-panel mounting screws.
5. Remove the mounting screws from the mechanism.
- Removal of the tape counter screws is Step 6., and removal of the meter mounting screws is Step 7.

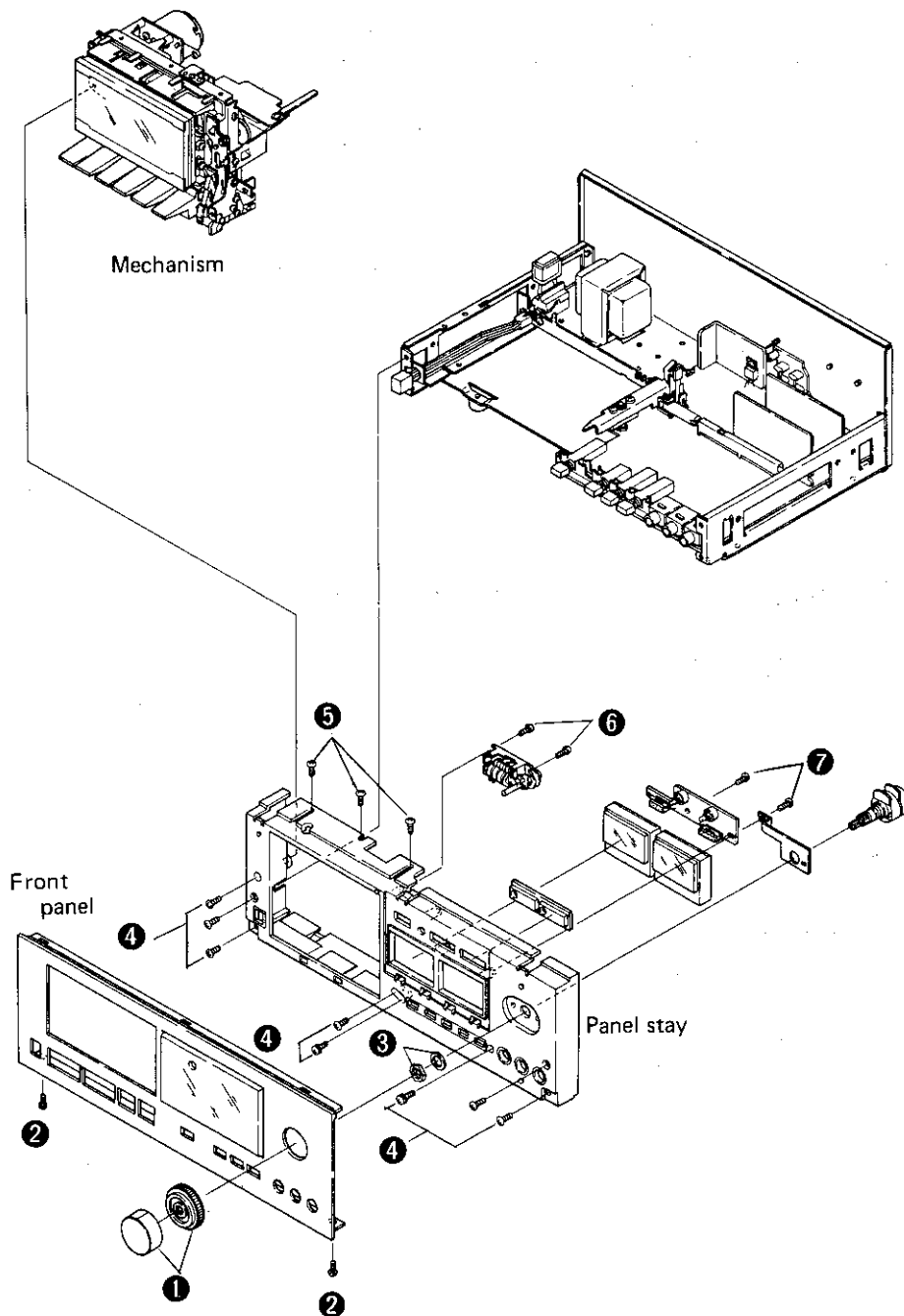

3.2 PINCH ROLLER

1. Remove the mounting screws from the cassette door.
2. Remove the E-washer so as to release the pinch roller and spring.

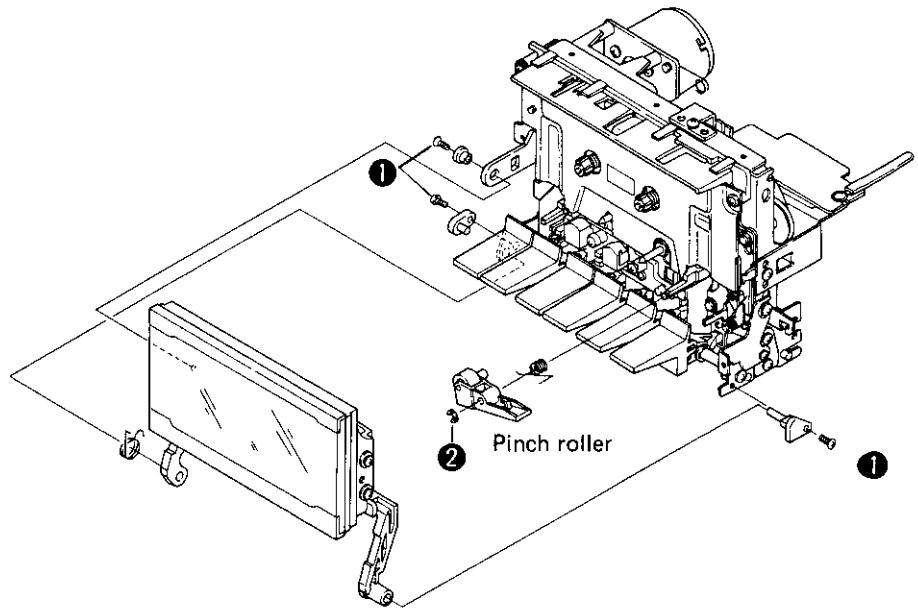

3.3 TAKE-UP REEL BASE

1. Remove the cassette door.
2. Remove the panel mounting screws.
3. Remove the counter belt.
4. Remove the cap.
5. Remove the washer so as to release the take-up reel base.

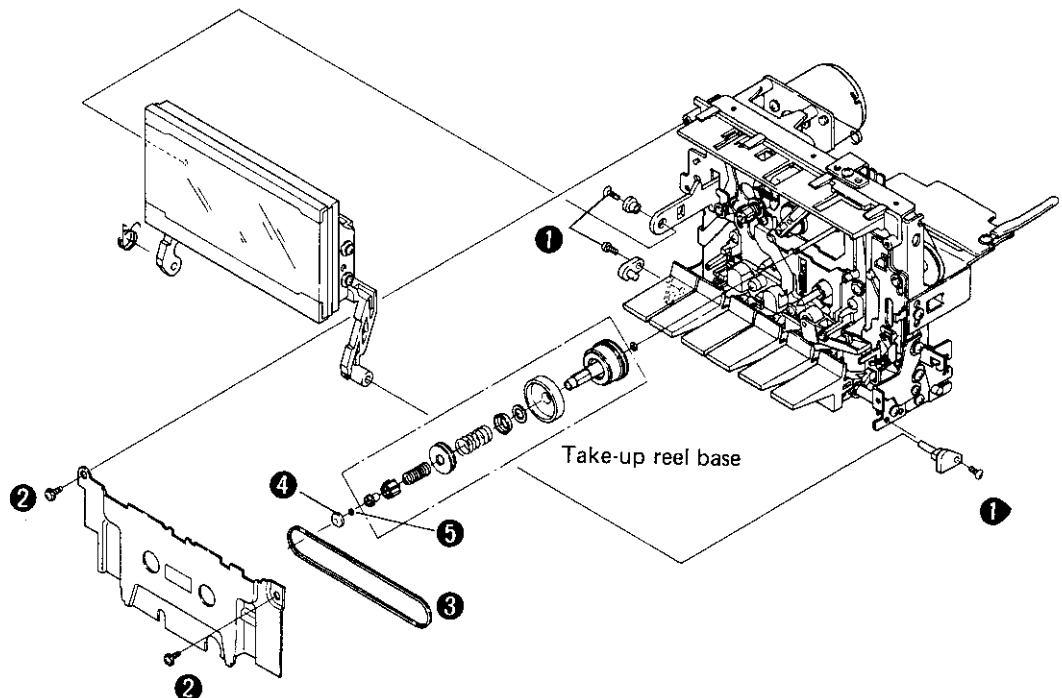

3.4 FLYWHEEL, BELT AND MOTOR

1. Remove the two angle pieces.
2. Pull off the flywheel. Be careful not to lose the two washers.
3. Remove the belt.
4. Remove the motor mounting screws.

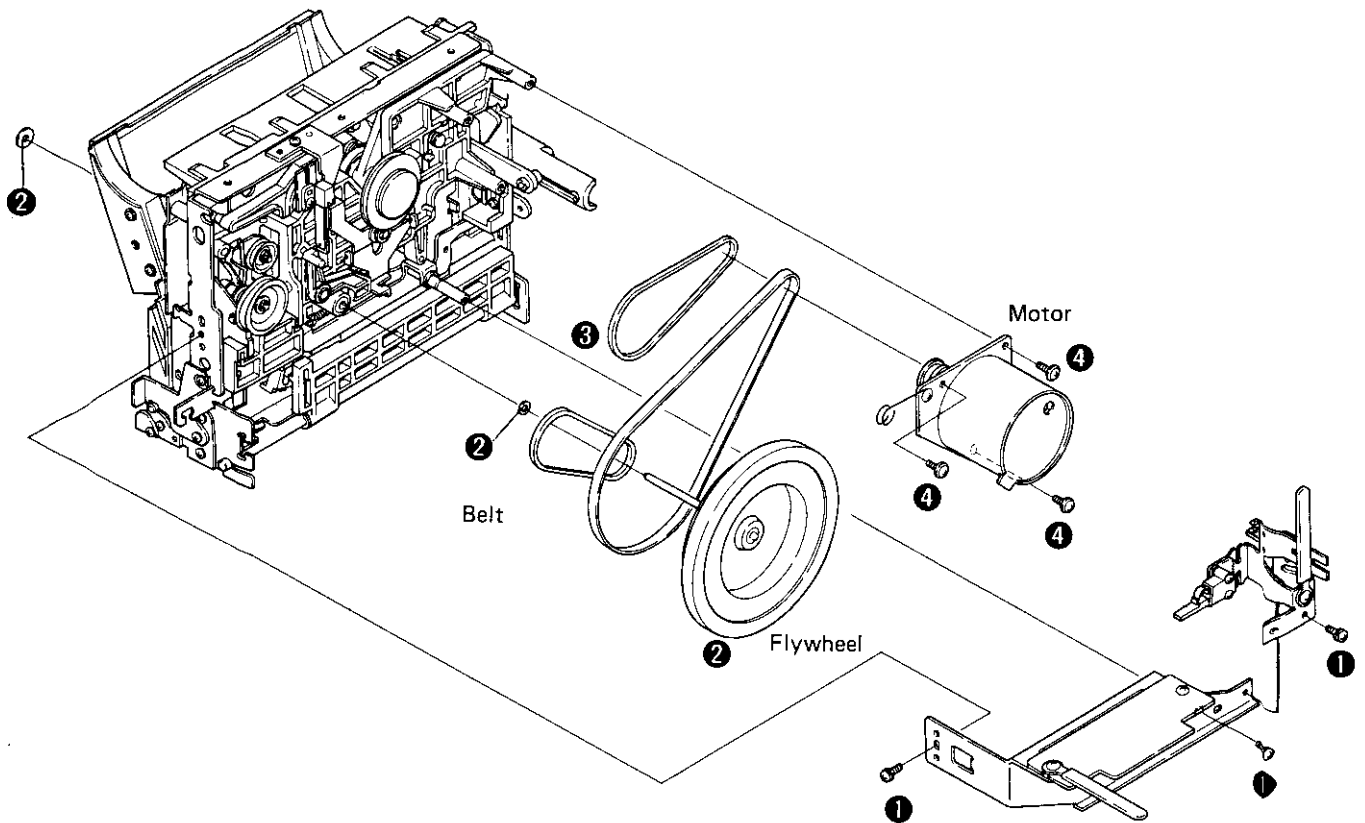

3.5 SUPPLY REEL BASE

1. Remove the panel.
2. Remove the plastic cover.
3. Remove switches A and B.
4. Remove the flywheel and the motor.
5. Remove the base of the mechanism.
6. Remove the cap and washer so as to release the supply reel base.

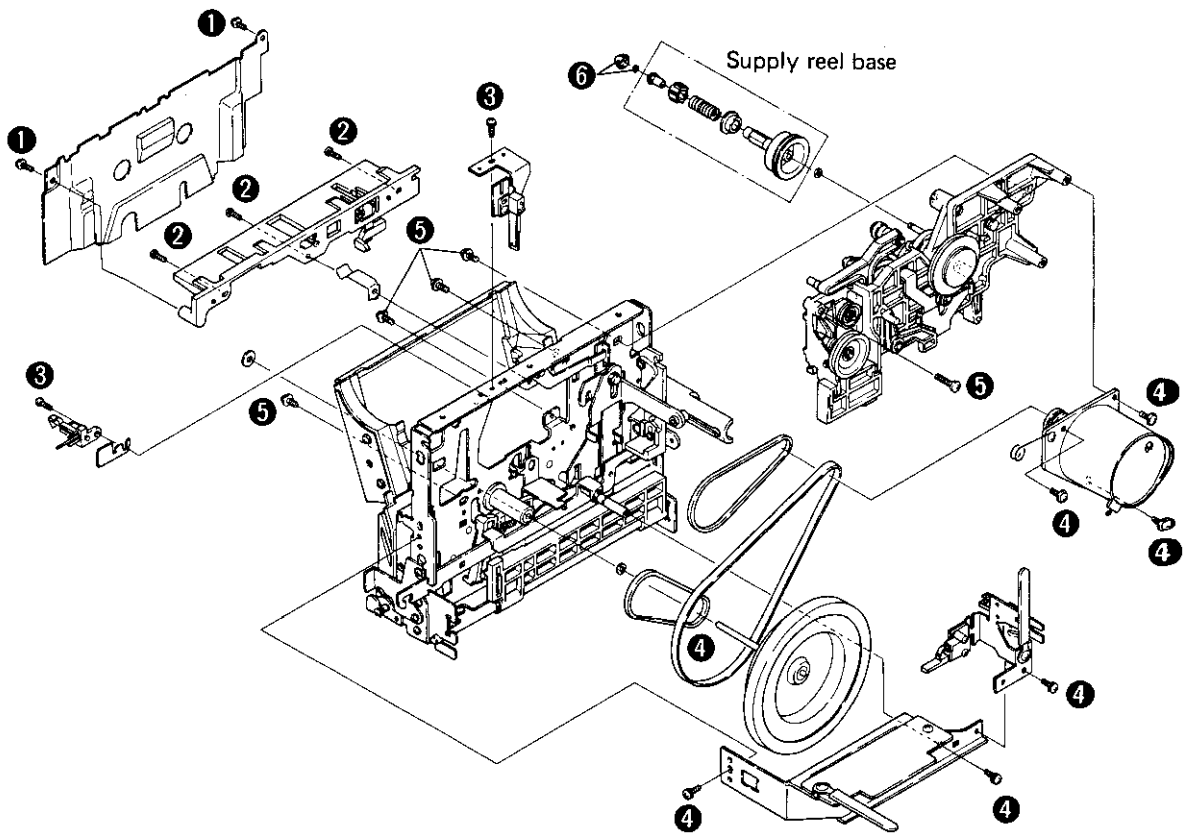

4. PARTS LOCATION

4.1 FRONT PANEL VIEW

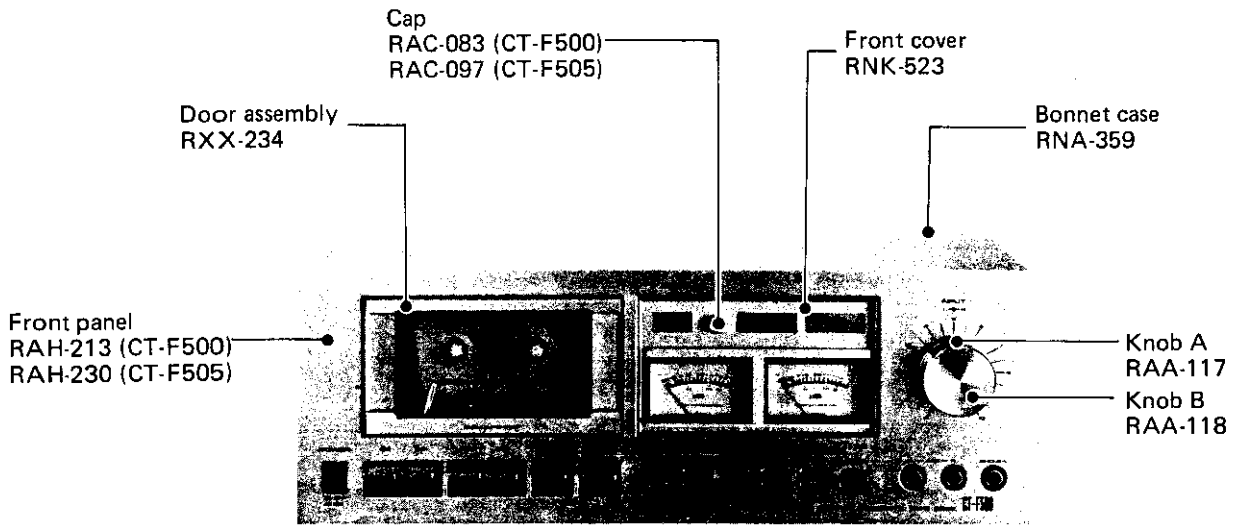

4.2 FRONT VIEW WITH FRONT PANEL REMOVED

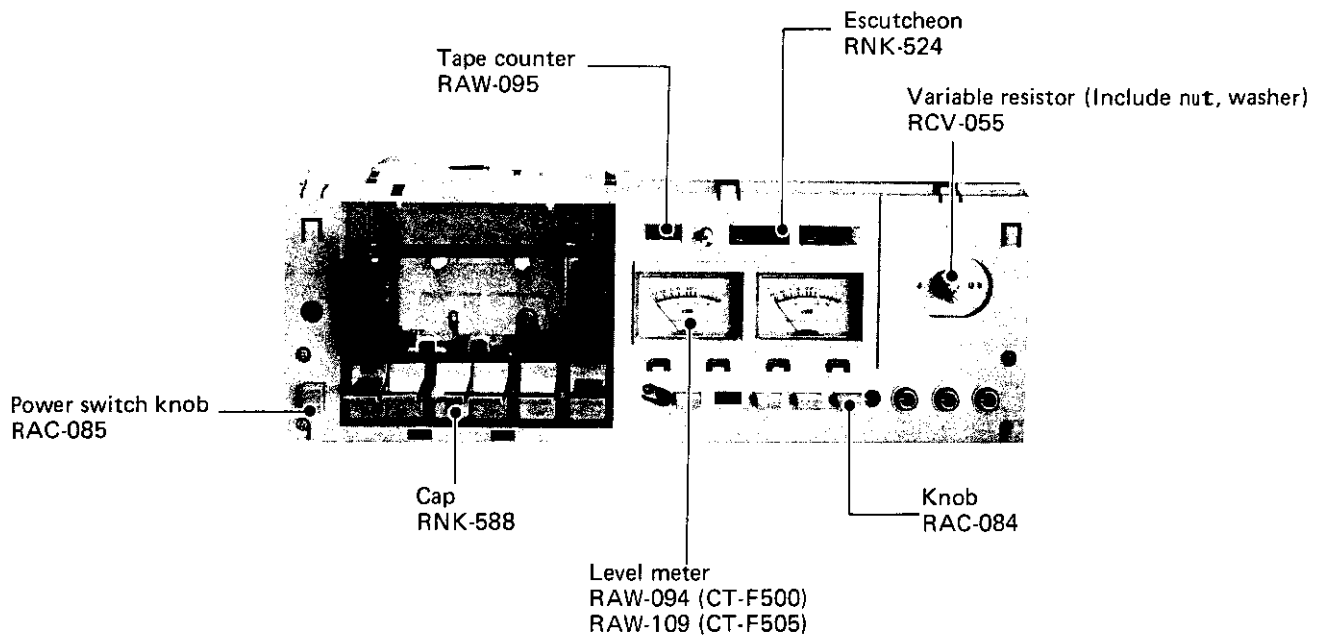

4.3 TOP VIEW WITH BONNET REMOVED

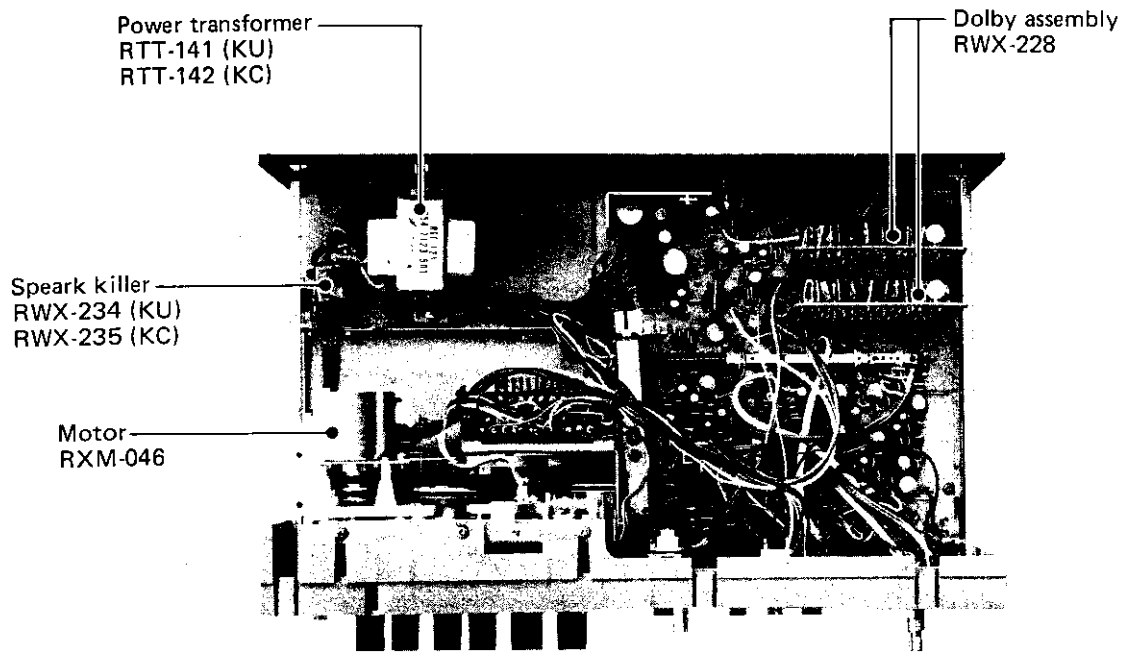

4.4 REAR PANEL VIEW

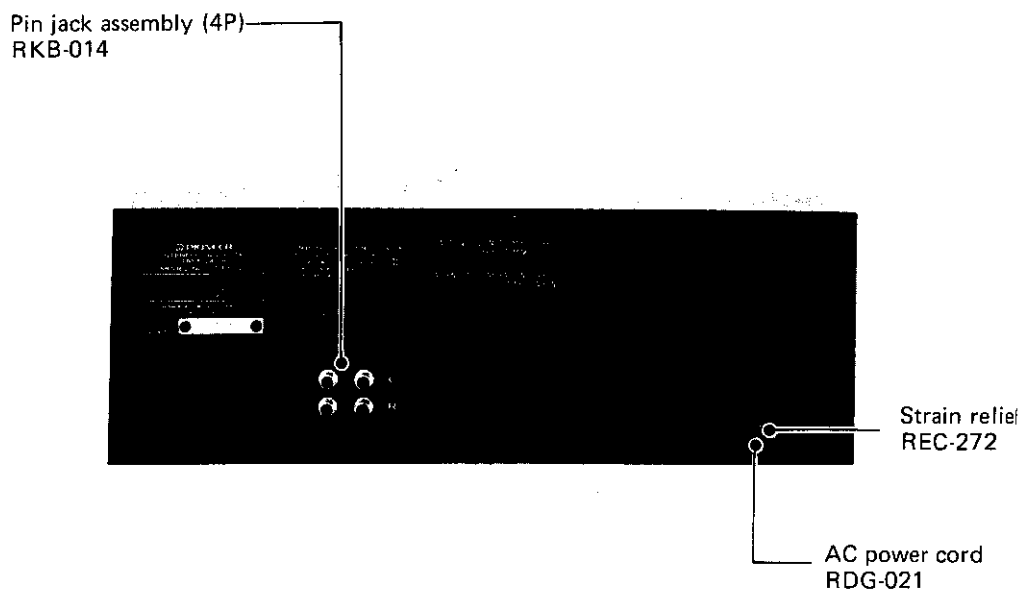

5. BLOCK DIAGRAM

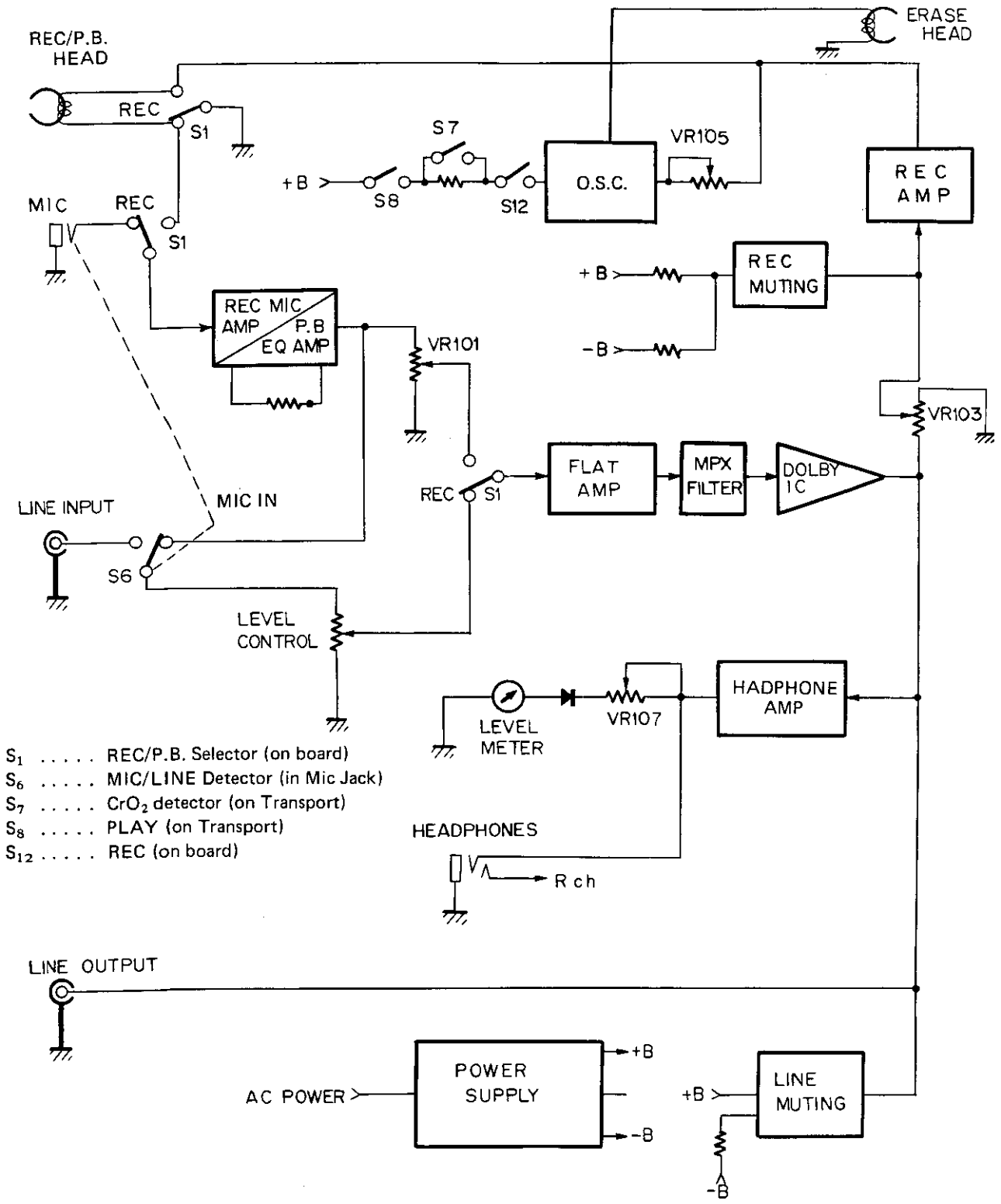

- S₁ REC/P.B. Selector (on board)
- S₆ MIC/LINE Detector (in Mic Jack)
- S₇ CrO₂ detector (on Transport)
- S₈ PLAY (on Transport)
- S₁₂ REC (on board)

6. LEVEL DIAGRAM

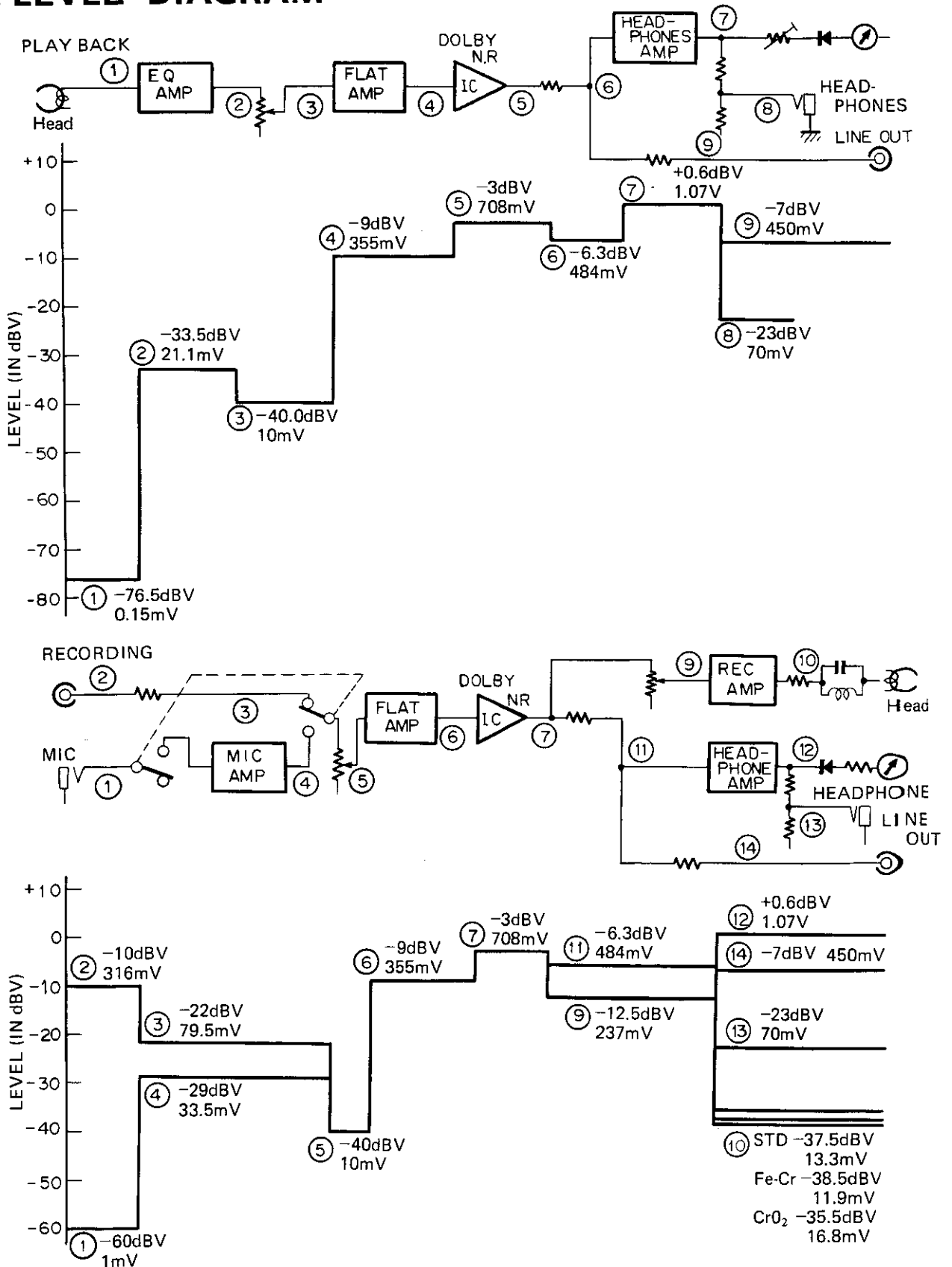

7. CIRCUIT DESCRIPTIONS

7.1 RECORDING AND PLAYBACK CIRCUIT

(Figs. 1, 2)

Signal Path at Record

The signal from MIC is amplified to a fixed level by the microphone amp (Q_{101} , Q_{103}), and then sent to the Dolby IC (PA4002) thru the input level control and flat amp (Q_{301} , Q_{302}) MPX filter.

The signal from LINE IN is applied directly to the input level control, and sent to the Dolby IC thru the flat amp MPX filter.

The frequency characteristic of the output signal of the Dolby circuit is adjusted by the recording equalizer circuit according to the kind of tape used at the recording amp (Q_{107}), and then applied to the REC HEAD. The output of the Dolby circuit is also the monitor output at LINE OUT.

Signal Path at Playback

The frequency characteristic of the signal from the PB HEAD is adjusted for the kind of tape-used by the playback equalizer amp (Q_{101} , Q_{103}), amplified to a fixed level by a flat amp, and then applied to the Dolby circuit. The output of the Dolby circuit is taken from LINE OUT as playback output.

NOTES

1. Fig. 1 only shows the signal path at recording. The additional circuitry and parts necessary at playback are omitted.
2. This circuit description is for the Lch.

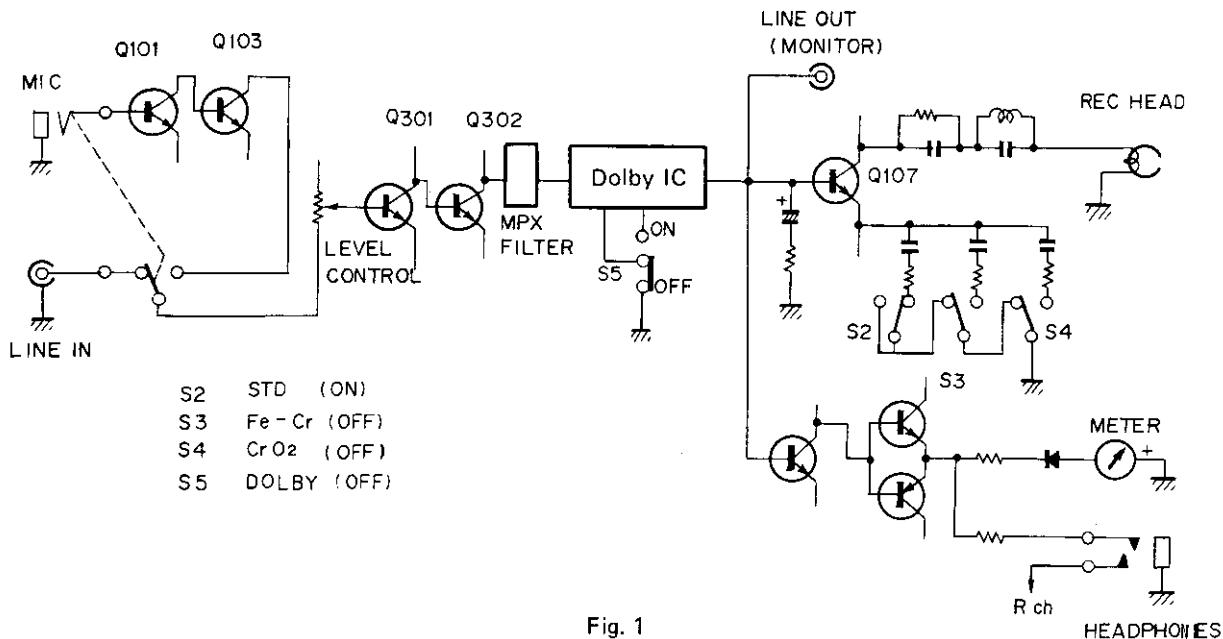

Fig. 1

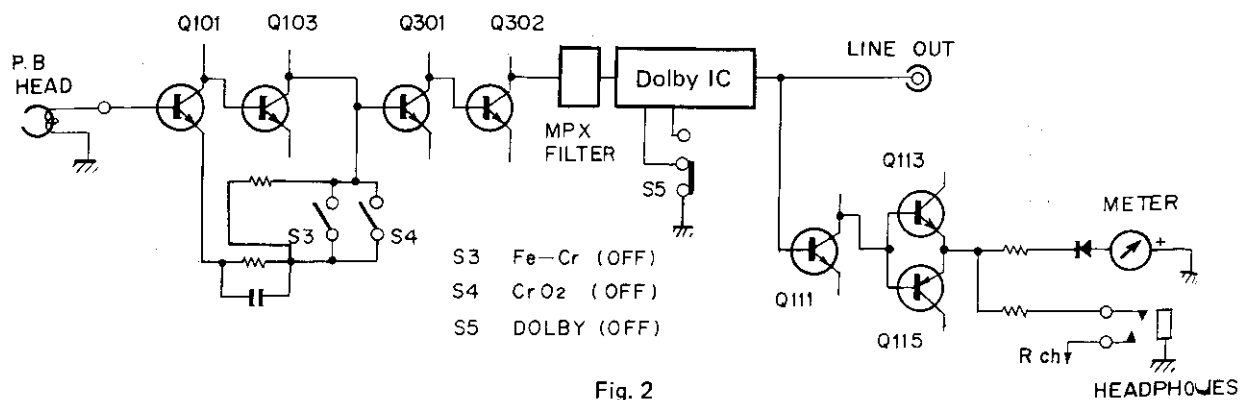

Fig. 2

- **The Microphone and Playback Equalizer Amp (Q_{101}, Q_{103})** is a two-stage direct-coupled amp using two NPN transistors. At record, the MIC input is amplified to a fixed level at a flat characteristic.

At playback, the frequency characteristic is adjusted by the playback equalizer amp only when CrO₂ or Fe-Cr tape is used.

- **Flat Amp (Q_{301}, Q_{302})**

The amp flat is a two-stage direct-coupled amp using two NPN transistors. It has a flat characteristic, and amplifies the recording input and playback input to a fixed level before applying them to the Dolby circuit.

- **Recording Amp (Q_{107})**

The recording amp consists of a single NPN transistor. A low-range compensation circuit is provided at the input, and a trap circuit to prevent the recording bias from flowing into the amp is provided at the output. The emitter of Q_{107} is a recording equalizer circuit that switches the frequency characteristic according to the tape used:

- **Headphone Amp ($Q_{111}, Q_{113}, Q_{115}$)**

The headphones amp is a SEPP circuit consisting of two NPN transistors and one PNP transistor. Its output is branched by resistors and applied to the HEADPHONES terminal and rectified and applied to the level meter.

- **Dolby IC (PA4002, Fig. 3)**

Recording Mode Operation

1. Input signals are first applied to the MPX filter where the FM broadcasting station's pilot signal is removed, and where an 85kHz bias trap is employed to prevent mis-operation of the Dolby noise reduction system.
2. From the MPX filter, the signals are passed on to the buffer amplifier whose output is divided into 2 routes. The main signal is passed directly to the adding amplifier, while the sub-signal is passed via the side chain amplifier and clipper before being recombined with the main signal in the adding amplifier.
3. Besides being applied to the clipper, the side chain amplifier output is also passed via the voltage controlled amplifier and integrating amplifier back to the side chain amplifier input, forming a variable filter circuit.
4. In addition to the above, the side chain amplifier output is further applied to a high-pass filter and rectifier where it is converted into a DC voltage for control of the voltage controlled amplifier.

5. When the level of the signal passed through the high-pass filter is low, the rectifier output DC voltage will be almost "0", resulting in a minimum turnover frequency for the variable filter. The level of the adding amplifier output will thus be 10dB (above 5kHz) higher than the level of the main signal, thereby contracting the dynamic range.
6. The clipper produces a time lag in the signal applied to the voltage-controlled amplifier, and since it is not capable of responding to sudden level changes, no uncontrolled signals will be applied to the adding amplifier.
7. When the level of the signal passed through the high-pass filter is high, the rectifier output DC voltage will also be high, and the variable filter turnover frequency will be increased. The sub-signal level will therefore become almost "0", so there will be no contraction of the dynamic range.

Playback Mode Operation

Although each section of the Dolby Processor operates in the same way as during recording mode, the sub-signal is derived from the output of the adding amplifier. And since the adding amplifier is an inversion amplifier (where output phase is opposite to input phase), the sub-signal will be of opposite phase, thereby forming an NFB loop.

In Dolby B noise reduction systems, contraction and expansion occur within a fixed frequency range determined by the variable filter circuit. And, in order to achieve perfectly symmetrical operation, it is necessary to fix a reference level for the operational point. This is the so-called "Dolby level", below which no contraction and expansion is performed

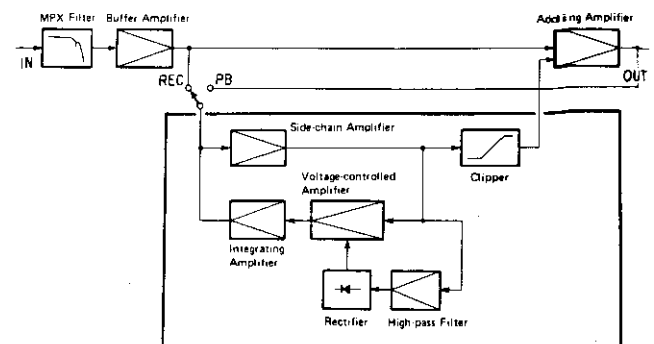

Fig. 3

7.2 MUTING CIRCUIT (Fig. 4)

AT POWER ON DURING PAUSE

Since the PLAY switch is turned on at this time, +B is supplied thru the path $R_{197} - C_{156} - R_{196}$. Q_{117} is turned on until C_{156} is discharged. When Q_{117} is turned on, so is Q_{118} .

When Q_{118} is turned on, +B is supplied thru the path $R_{201} - Q_{118} - R_{202} - Q_{109}$, and Q_{109} is turned on.

When Q_{109} is turned on, the LINE OUT terminal is shorted, and an output signal is not output.

IN THE STOP STATE

+B is supplied thru the path $S_8 - R_{203} - Q_{109}$, and Q_{109} is turned on. When the PLAY lever is pushed, S_8 is turned off.

AT FF, REW

When the FF or REW lever is pushed, S_9 is turned on, +B is supplied thru the path $S_9 - R_{203} - Q_{109}$, and Q_{109} is turned on.

S_9 prevents the signal from appearing at LINE OUT when the PLAY lever has been pushed at FF and REW.

7.3 MUTING RELEASE (Figs. 4, 5)

AT PLAY

When the PLAY lever is pushed, +B supplied to Q_{109} thru S_8 is removed.

Instead, -B is supplied to Q_{109} thru R_{204} , and Q_{109} is turned off.

S_{1-11} mutes the REC amp by applying +B to Q_{105} thru R_{173} .

AT REC

The operation that turns Q_{109} off is identical to that at PLAY. Since the REC lever is pushed in this case, S_{12} is turned on, and +B is supplied to the oscillator circuit thru the path $S_8 - R_{215} - Q_{120}$.

S_{1-11} removes the +B supplied to Q_{105} and supplies -B to Q_{105} thru R_{171} instead, and Q_{105} is turned off.

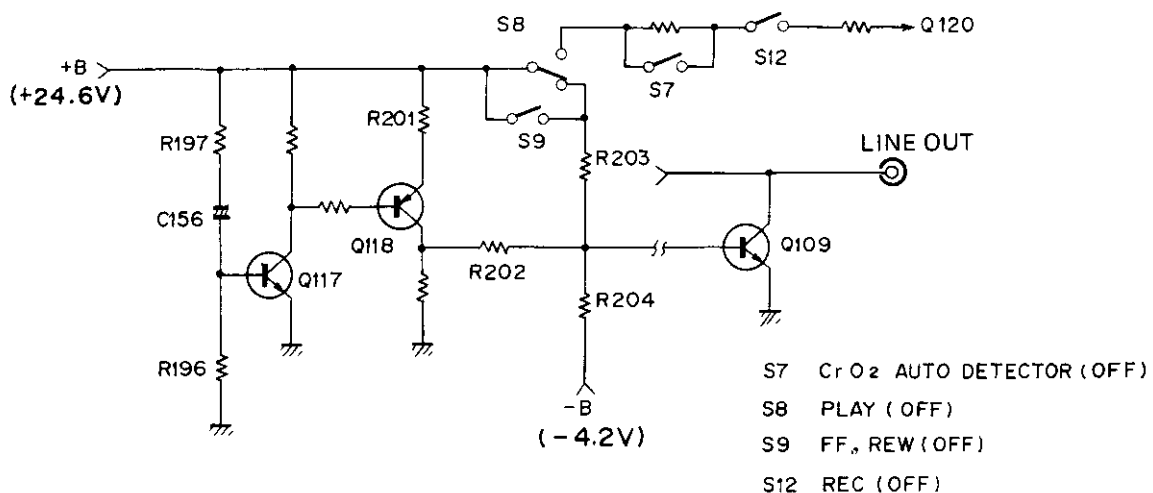

Fig. 4

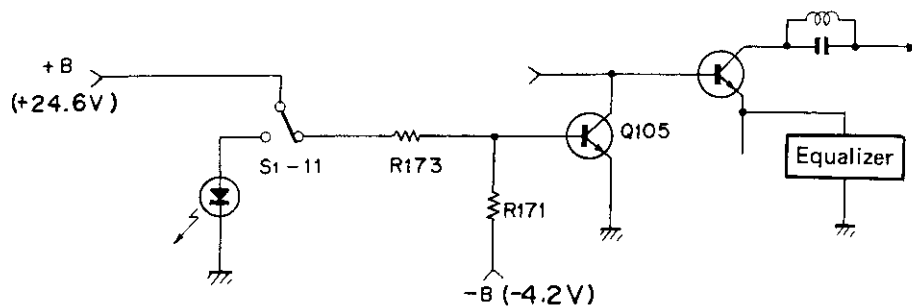
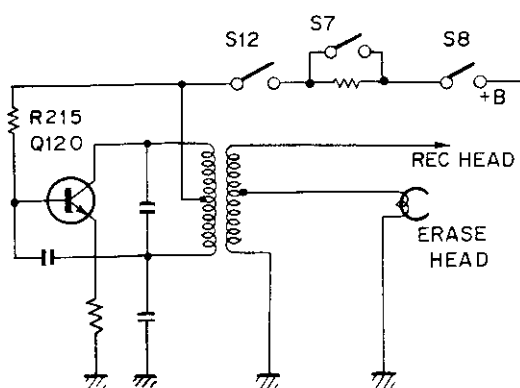

Fig. 5

7.4 OSCILLATOR CIRCUIT (Q₁₂₀, Fig. 6)

The oscillator circuit consists of a single transistor, and supplies the approximately 85kHz erasing current and bias current to the ERASE HEAD and REC HEAD at recording.

+B is supplied to the oscillator circuit only when the REC lever (S₁₂) or PLAY lever (S₈) is pushed. STD/Fe-Cr and CrO₂ tape bias switching is accomplished automatically by means of the CrO₂ detection switch (S₇).



- S7 CrO₂ AUTO DETECTOR (OFF)
 S8 PLAY (OFF)
 S12 REC (OFF)

(Q₁₂₀, Fig. 6)

7.5 POWER SUPPLY CIRCUIT

The secondary side of the power transformer drives three systems; i.e., amp, motor, lamp. The amp system power is full-wave rectified, and then regulated (+24V) by a transistor (Q₁₁₉) and zener diode (ZD₁₀₁) to provide the +B supply. The motor system power is full-wave rectified (+16V) and applied to the motor thru S₁₁. S₁₁ is turned on when the PLAY, FF, or REW lever is pushed.

Since the meter lamp is illuminated by AC, the lamp system does not have a rectification circuit. The minus supply (-B) for muting is obtained by half-wave rectification (-4.2V) of the lamp AC supply.

8. MECHANICAL DESCRIPTIONS

8.1 PLAY OPERATION

1. When the PLAY button is pushed, the motor switch is turned on by movement of the head base, and the motor rotates.
2. The rotation of the motor is transmitted to the flywheel by belt A. At the end of the flywheel shaft is the capstan. When the pinch roller is pushed against this capstan, the tape is driven at a constant speed.
3. The rotation of the motor is transmitted to pulley A (idler A) by belt B and to the take-up reel base thru idler B; the tape is then wound. Belt C connects the take-up reel base and the tape counter.

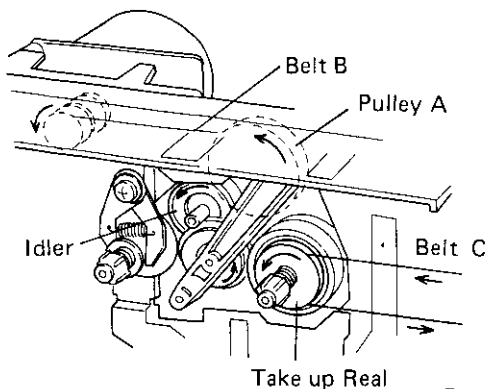

Fig. 7

8.2 AUTO-STOP OPERATION (Fig. 8 ~ Fig-11)

1. The rotation of the flywheel is transmitted to a worm gear thru belt D. The worm gear rotates shaft A. There are two cams on shaft A, with a projection for auto-stop between them.
2. While the tape is running, belt E transmits the rotation of the take-up reel base to plate A. There is also a projection for auto-stop on plate A, the same as on shaft A.
3. At PLAY and FF, the projection on plate A moves along the outside cam, and at REW, the projection on plate A moves along the inside cam.
4. When the tape is stopped, the projection on plate A is brought to the center by the depression in the cam. (Fig- 9)
5. The projection on shaft A engages the projection on plate A, and plate A is pushed down. (Fig- 10)
6. When plate A is pushed down, plate C is moved thru plate B, and the operation buttons are unlocked. (Fig- 11)

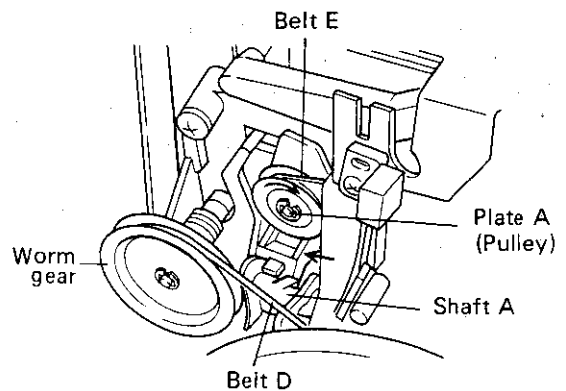

Fig. 8

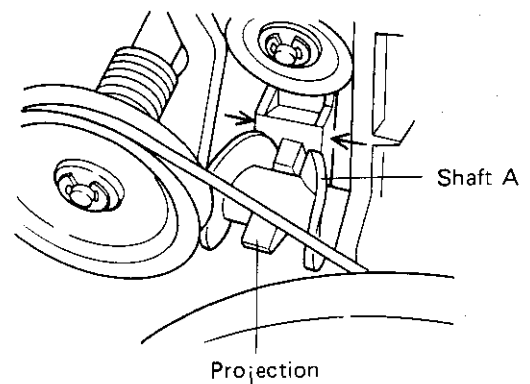

Fig. 9

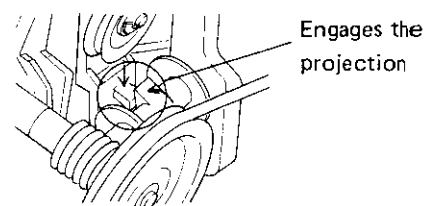

Fig. 10

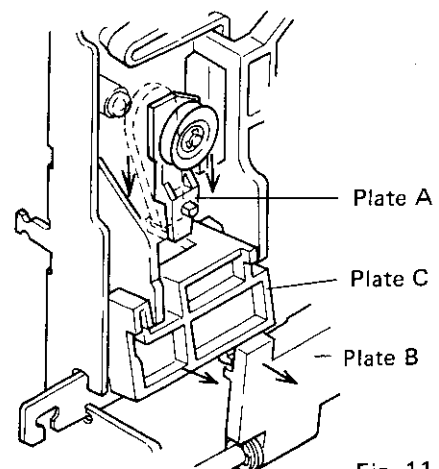

Fig. 11

8.3 FF, REW

1. When the FF button is pushed, the rotation of idler A (pulley A) is transmitted to the take-up reel base thru idler C.
2. Since the pinch roller is separated from the capstan at FF operation, the tape is wound at high speed (Fig. 12).
3. When the REW button is pushed, rotation of idler A is transmitted directly to the supply reel base, and the tape is wound at high speed (Fig. 13).

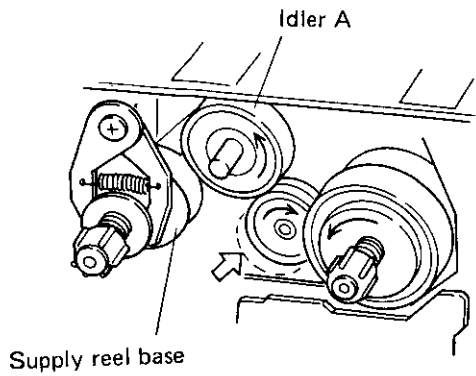

Fig. 12

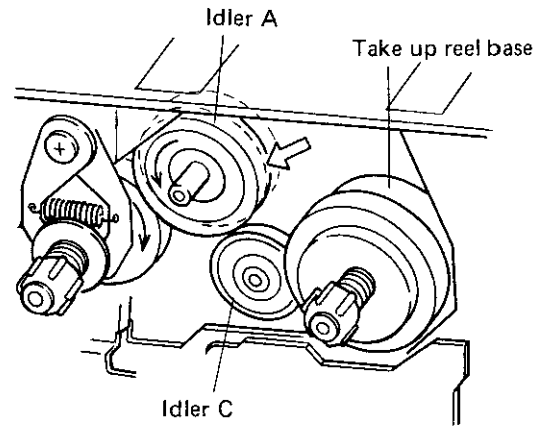

Fig. 13

9. MECHANICAL ADJUSTMENTS

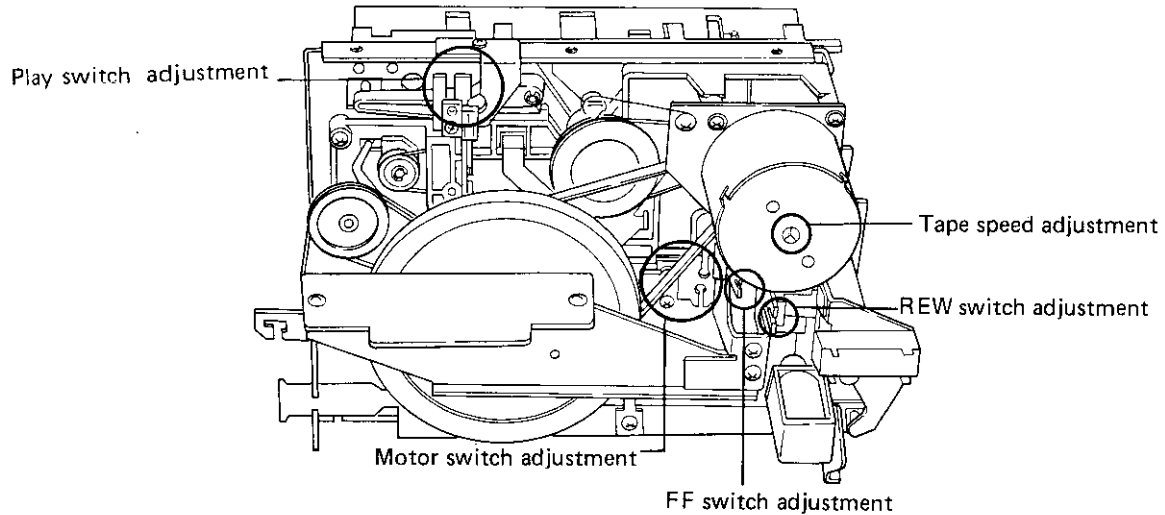

Fig. 14 Mechanical Adjustment Points

Precautions

- Do not spill oil on the reel bases, belts, or idlers.
- Disassemble as few parts as possible.
- Refer to Fig. 14 for points of adjustments.

9.1 TAPE SPEED ADJUSTMENT

1. Connect a frequency counter to the OUTPUT (PLAY) terminals.
2. Play the 3kHz section of the STD-301 test tape used for tape speed and wow and flutter checks.
3. Adjust the semi-fixed resistor inside the motor (see Fig. 15) so that the frequency lies within the 2,995Hz — 3,010Hz range at the beginning of the tape.
4. Turning this semi-fixed resistor in the clockwise direction will increase tape speed, while turning in the opposite direction will slow the speed down.

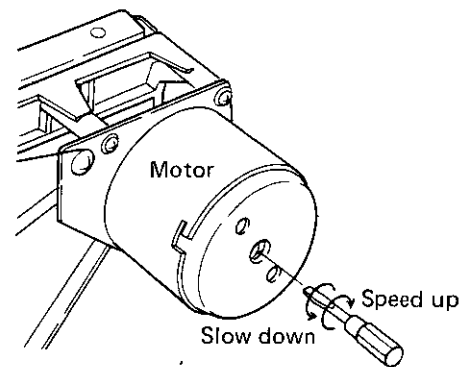

Fig. 15 Tape Speed Adjustments

9.2 MOTOR SWITCH ADJUSTMENT

Normal Motor Switch Operation

The motor switch should always turn on (leaf switch contact closure) whenever the PLAY, FF, or REW keys are pressed, and also turn off again whenever the STOP key is pressed.

Adjustment

If the motor switch fails to turn on and off properly, insert a screw driver in the groove shown in Fig. 16, and adjust the position of the motor switch to ensure reliable on/off operation.

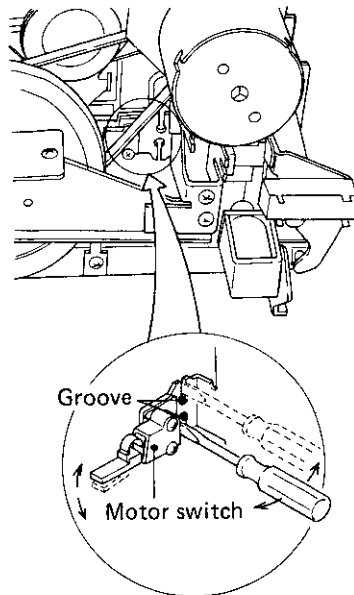

Fig. 16 Motor Switch Adjustment

9.3 FF (REW) SWITCH ADJUSTMENT

Normal F.F. Switch Operation

The FF (REW) switch should turn on (leaf switch contact closure) whenever the FF (REW) key is pressed, and turn off again whenever the STOP key is pressed.

Adjustment

If the FF (REW) switch to turn on and off properly, insert a screw driven in the groove shown in Fig. 17, and adjust the position of the switch to ensure reliable on/off operation.

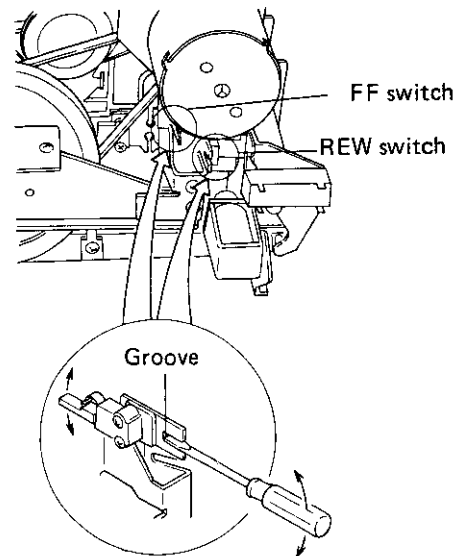

Fig. 17 FF and REW Switch Adjustments

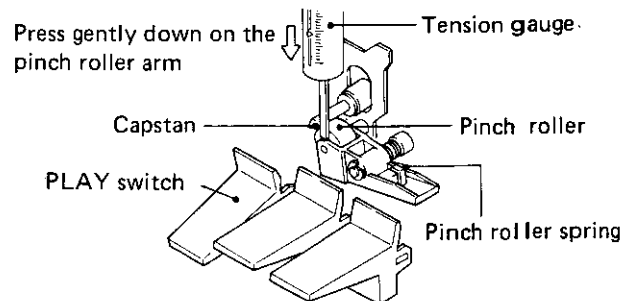

Fig. 18 Pinch Roller Pressure Adjustment

9.4 PINCH ROLLER PRESSURE ADJUSTMENT

1. Press the PLAY key, and gently press down against the pinch roller arm with a tension gauge (spring pressure balance with approx. 500g scale) (see Fig. 18).
2. The pressure required to push the pinch roller away from the capstan should be within 300 to 400g. If the tension gauge reading lies outside this range, replace the pinch roller spring.

9.5 REEL BASE TORQUE ADJUSTMENT

Measure the reel base torques during play, fast forward and rewind modes with a torque meter (see Fig. 19). If the measured values do not lie within the allowable ranges listed in Table 1, replace the brake spring, brake shoe, or the supply or take-up reel bases.

	Take-up reel base	Supply reel base
At PLAY	37—52g·cm	*5—9g·cm or less
At FF	70—105g·cm	*5—9g·cm or less
At REW	*8g·cm or less	70—105g·cm

Table 1

9.6 PLAY SWITCH ADJUSTMENT

Press the PLAY key down slowly, and adjust the switch bracket so that the PLAY key locks at the same time that the PLAY switch is turned on.

Then connect a millivoltmeter to the LINE outputs, and confirm the absence of switching noise while switching back and forth between PLAY and STOP. (Fig. 20)

9.7 LEAF SWITCH TIMING ADJUSTMENT

1. Slowly press down on the REC lever so as to cause the REC/P.B switch to operate, and then adjust the tip of Fig. 21 using a screwdriver, until the leaf switch operates.

9.8 PAUSE TIMING ADJUSTMENT

1. With the unit in the PLAY position, slowly press down on the PAUSE lever, and then bend the pause plate so that the pinch roller becomes separated from the capstan by 1 to 2mm. (Fig. 22)
2. After completing the above adjustment, release the PAUSE lever and check that the pinch roller is correctly pressed against the capstan.

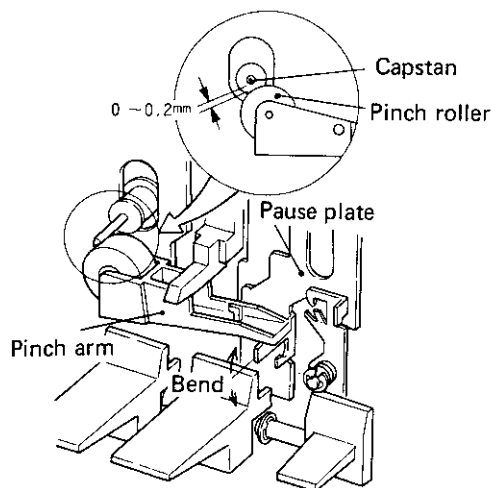

Fig. 22

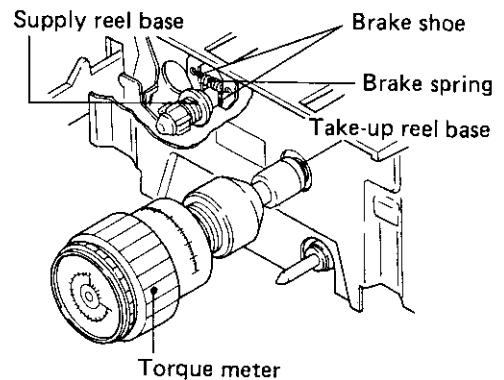

Fig. 19 Reel Base Torque Adjustment

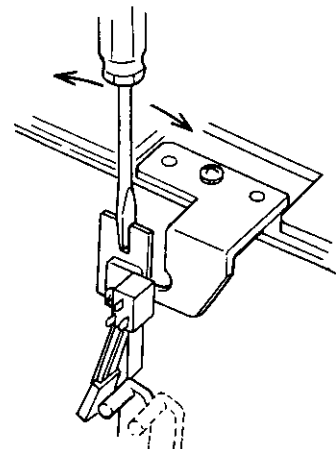

Fig. 20

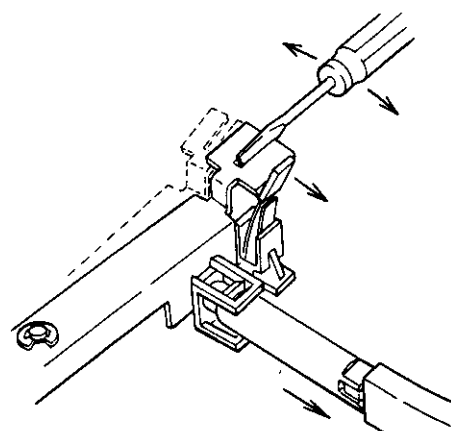

Fig. 21

10. ELECTRICAL ADJUSTMENTS

Prior to commencing electrical adjustments, first check the following:—

1. All mechanical adjustments should be completed.
2. The heads should be cleaned, and properly demagnetized.
3. Set the measuring level to 0dB = 1V by connecting a 50kΩ (47 — 52kΩ) dummy load to the LINE output terminals.
4. Employ the following test tapes.
 - STD-331A..... for general playback purposes
 - STD-341A..... for playback adjustments
 - STD-601..... STD blank tape
 - STD-603..... CrO₂ blank tape

Note:
Although both sides of test tapes are available, always use side A.

5. Prepare the following measuring equipment.; two millivoltmeters, low frequency oscillator, oscilloscope, attenuator.
6. Unless otherwise designated, "recording mode" in the following paragraphs refers to normal recording mode with PLAY and REC keys depressed, and using a cassette half not equipped with chrome detector apertures.
7. The adjustments must be performed in the order shown in the Adjustment Procedure. If the order is changed, proper adjustments will not be possible, and the tape deck will fail to operate with optimum performance. The positions to be adjusted are shown in Figs. 23, 24, and 25.

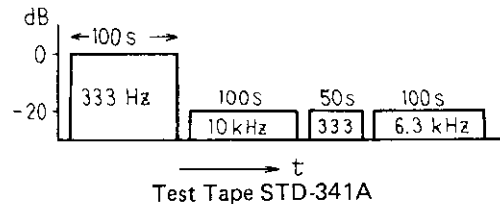

- VR₁₀₁, VR₁₀₂ .. Play back level adjustment
- VR₁₀₃, VR₁₀₄ .. Rough adjustment of recording current
- VR₁₀₅, VR₁₀₆ .. Adjustment of recording bias and recording/playback frequency response.
- VR₁₀₇, VR₁₀₈ .. Level meter adjustment
- *VR₁₀₁, 103, 105, 107 .. L ch
- VR₁₀₂, 104, 106, 108 .. R ch

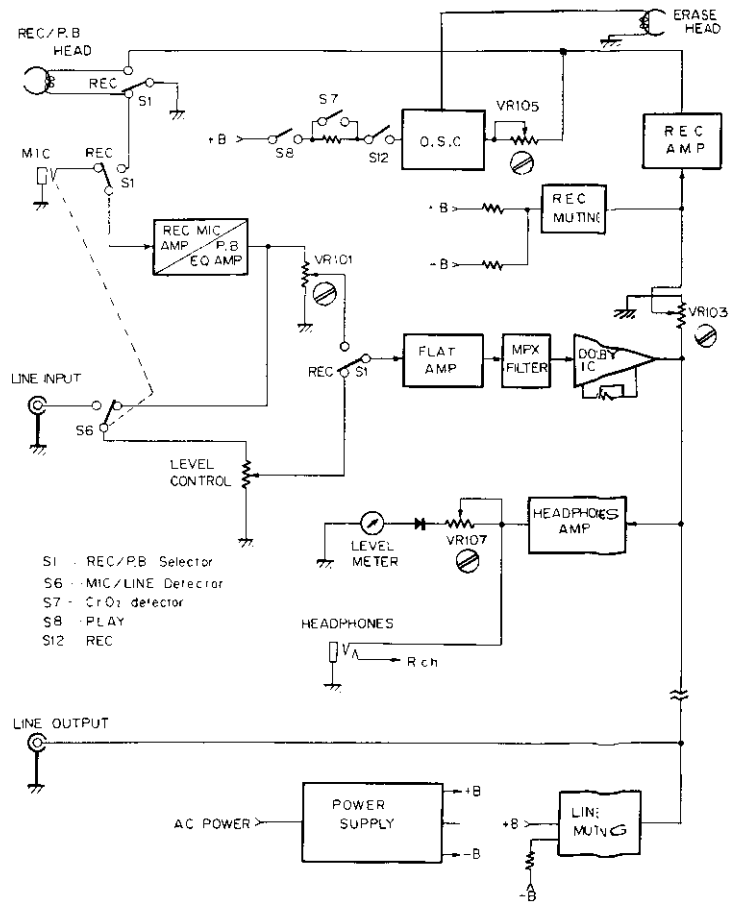

Fig. 23 Adjustment positions

ADJUSTMENT PROCEDURE

Playback

1. Head azimuth adjustment
2. Playback equalizer check
3. Playback level adjustment

Recording

4. Level meters 0dB adjustment
5. Rough adjustment of recording current
6. Rough adjustment of recording bias
7. Playback frequency response adjustment
8. Recording level adjustment

Note:

The recording trap is not adjustable.

10.1 HEAD AZIMUTH ADJUSTMENT

1. Connect millivoltmeters to the PLAY output terminals.
2. Turn VR₁₀₁ (L. ch) and VR₁₀₂ (R. ch) up to maximum levels (full around in, unclockwise direction).
3. Set the TAPE selector to the STD position.
4. Play the 10kHz section of the STD-341A test tape, and adjust the head azimuth adjustment screw (see Fig. 24) to obtain maximum output levels (millivoltmeter readings) in both left and right channels.
5. Complete the adjustment by locking the screw, using screw tight green No. 300 (part no. GYL-001).

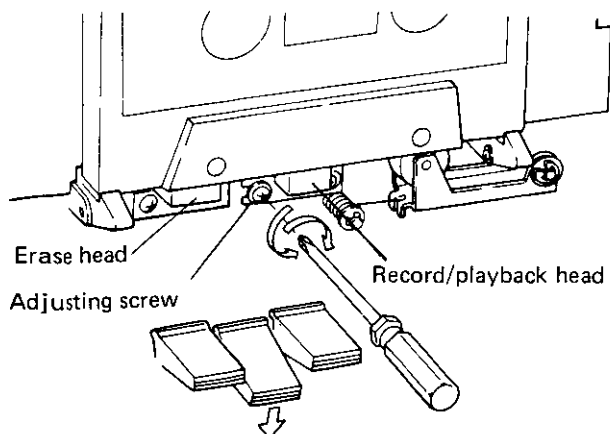

Fig. 24

10.2 PLAYBACK EQUALIZER CHECK

1. Again connect millivoltmeters to the PLAY output terminals.
2. Also set the TAPE selector to the STD position.
3. Turn VR₁₀₁ (L. ch) and VR₁₀₂ (R. ch) back around to their approximate center positions.
4. Play the 333Hz, -20dB section of the STD-341A test tape, and read the values shown in the millivoltmeters.
5. Then play the 6.3kHz section of the same test tape, and confirm that the millivoltmeters read 0.5dB \pm 0.5dB higher than the readings given in step 4 above.
6. Without making any other changes, set the TAPE selector to the Fe-Cr position, and confirm that the frequency response at 6.3kHz is -3.5dB \pm 1.0dB below the reference level at 333Hz.

10.3 PLAYBACK LEVEL ADJUSTMENT

This adjustment must be performed accurately since it determines the Dolby level.

1. Connect the millivoltmeters to the TP terminals of the Dolby assembly. The TP terminals are on the pattern side (see Fig. 25).
2. Turn the DOLBY NR switch OFF, and set the TAPE selector to the STD position.
3. Play the 333Hz, 0dB section of the STD-341A test tape, and adjust VR₁₀₁ (L. ch) and VR₁₀₂ (R. ch) to obtain millivoltmeter readings of 1dBv (1.12V).

10.4 LEVEL METERS 0dB ADJUSTMENT

1. Connect the millivoltmeters to the Dolby assembly TP terminals again.
2. Put the deck into recording mode, and apply the 333Hz, -10dBv (316mV) signal to the REC input terminals.
3. Then adjust the INPUT volume control to give -3dBv (700mV) readings in the millivoltmeters.
4. Finally adjust VR₁₀₇ (L. ch) and VR₁₀₈ (R. ch) to obtain 0dB readings in the level meters.

10.5 ROUGH ADJUSTMENT OF RECORDING CURRENT

Since the level is extremely low, be particularly careful to avoid external induction noise during this adjustment.

1. Set the TAPE selector to the STD position, and connect the millivoltmeters to the PLAY output terminals.
2. Apply the 333Hz, -10dBv (316mV) signal to the REC input terminals, and then press the REC key (but not the PLAY key).

3. Adjust the INPUT volume control to obtain readings of -7dBv (446mV) in the millivoltmeters.
4. Cut the copper foil pattern at the point indicated by a mark in the vicinity of terminals nos. 42 and 45, and insert a 10Ω resistor.
5. Next connect one of the millivoltmeters between terminal no. 42 (L. ch) and no. 41 (ground) on the mother board assembly, and the other millivoltmeter between terminal no. 45 (R. ch) and no. 44 (ground).
6. Then adjust the mother board assembly VR_{103} (L. ch) and VR_{104} (R. ch) to obtain 0.4mV ($40\mu\text{A}$) readings in the millivoltmeters.
7. After the completion of the above adjustments, remove the 10Ω resistor insert during step 4, and connect the copper foil pattern with a jumper lead.

10.6 ROUGH ADJUSTMENT OF RECORDING BIAS

1. Connect the millivoltmeters between terminal no. 41 and 42, and 44 and 45 as before.
2. Put the TAPE selector in the STD position, and load a STD cassette half.
3. Put the deck into recording mode, and turn the INPUT volume control down to minimum level.
4. Adjust VR_{105} (L. ch) and VR_{106} (R. ch) so that the millivoltmeters read 45mV ($450\mu\text{A}$).

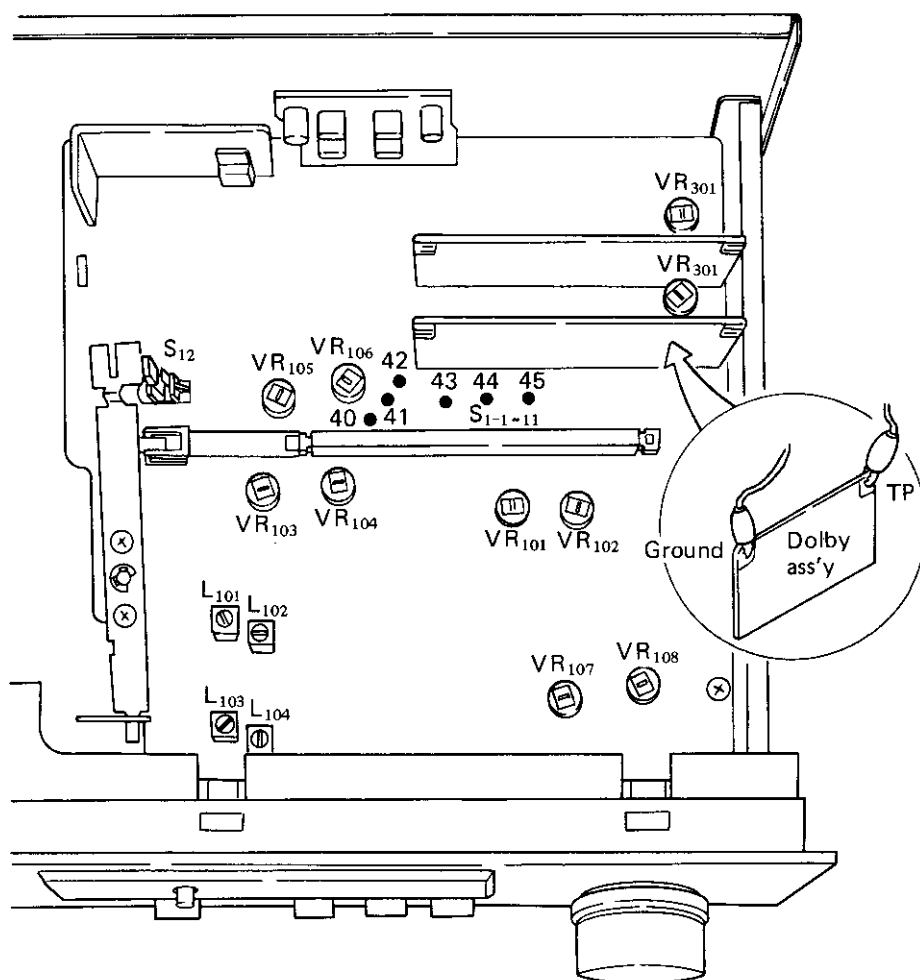

Fig. 25 Adjustment Positions

10.7 RECORD AND PLAYBACK FREQUENCY ADJUSTMENT

1. Set the TAPE selector to the STD position, and turn the DOLBY NR switch off.
2. Connect the millivoltmeters to the PLAY output terminals.
3. Put the deck into recording mode, and apply a 333Hz, -30dBv (31.6mV) signal to the REC input terminals.
4. Adjust the INPUT volume control until the millivoltmeters read -27dBv (44.6mV).
5. Then record this signal on the STD-601 test tape.
6. Next record a 6.3kHz signal on the same tape, and adjust VR₁₀₅ (L. ch) and VR₁₀₆ (R. ch) in order to eliminate any difference in playback output level between the 333Hz and 6.3kHz signals. This step will have to be repeated several times before any changes in frequency response become apparent. Continue to record and playback repeatedly until the 6.3kHz playback level is the same as the 333Hz playback level.
7. Then record and playback signals covering the 63Hz to 12kHz range, and check that the record/playback frequency response satisfies the curve supplied in Fig. 26.
8. Record the 333Hz and 6.3kHz signals on the STD-603 test tape, and check that the difference between the two signals in playback output level is no more than $0.5\text{dB} \pm 1\text{dB}$.
9. Again record and playback signals up to 12kHz, and check that the record/playback frequency response satisfied the specifications.
10. Lastly, connect one of the millivoltmeters between terminal no. TP₁ (L. ch) and no. 41 (ground) on the mother board assembly, and the other millivoltmeter between terminal nos. TP₂ (R. ch) and no. 44 (ground). Put the deck into recording mode, and check that the bias leak voltage does not exceed 1V.

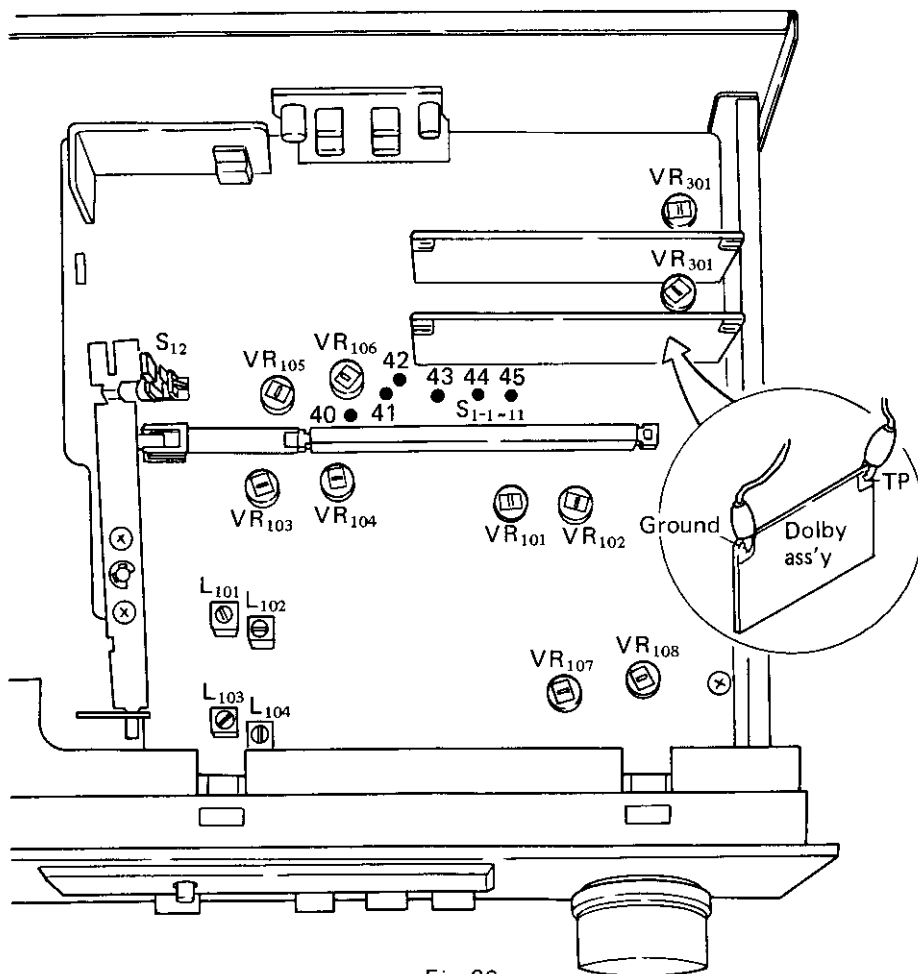

Fig. 26

10.8 RECORDING LEVEL ADJUSTMENT

1. Set the TAPE selector to the STD position, and turn the DOLBY NR switch on.
2. Connect the millivoltmeters to the Dolby assembly TP terminals.
3. Apply a 333Hz, -10dBv (316mV) signal to the REC input terminals, and put the deck into recording mode.
4. Adjust the INPUT volume control so that the millivoltmeters read -3dBv (700mV).
5. Record the 333Hz signal onto the STD-601 test tape. Play this signal back, and adjust VR₁₀₃ (L. ch) and VR₁₀₄ (R. ch) on the mother board assembly to obtain millivoltmeter readings of -3dBv (700mV).
 Note: the change in playback level effected by the VR₁₀₃ and VR₁₀₄ adjustments will not be evident straight away, so repeat the playback and recording operations several times. Continue to repeat this process until an output level of -3dBv (700mV) is obtained.
6. Record the 333Hz, -10dBv (316mV) signal onto to the STD-603 test tape, and check that the millivoltmeters read -3dBv (700mV) ± 1.5dB during playback.

10.9 DOLBY CIRCUIT ADJUSTMENT

1. Turn the DOLBY NR switch OFF.
2. Rotate VR₃₀₁ (for both left and right channels) full around in the counter clockwise direction.
3. Connect a millivoltmeter to the TP terminal of the Dolby Ass'y (RWX-228).
4. Press the REC lever by itself. (When only the REC lever is pressed, the amplifier section is put into recording mode, but without the operation of the bias oscillator).
5. Apply a 1kHz/-10dBv (316mV) signal to the LINE INPUT terminals.
6. Adjust the INPUT level control to obtain a 0dBv (1V) reading in the millivoltmeter.
7. Turn the DOLBY NR switch ON.
8. Then apply a -50dBv (3.1mV) signal to the input, and readjust VR₃₀₁ to obtain a millivoltmeter reading of -34dBv (19.9mV).

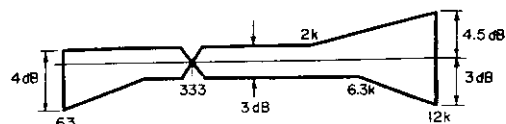

Using STD-601 and the STD Position, with DOLBY NR OFF.

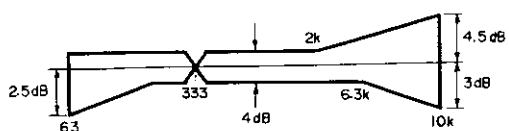

Using STD-601 and the STD Position, with DOLBY NR ON.

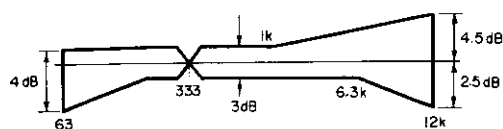

Using STD-602 and the CrO₂ Position, with DOLBY NR OFF.

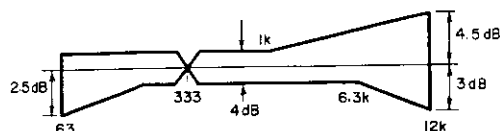

Using STD-602 and the CrO₂ Position, with DOLBY NR OFF.

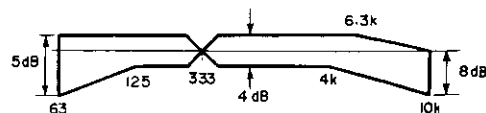

Using STD-601 and the FeCr Position, with DOLBY NR OFF.

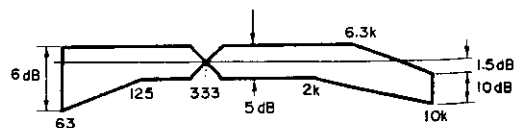

Using STD-601 and the FeCr Position, with DOLBY NR ON.

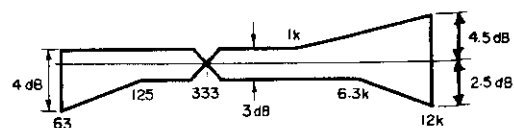

Using SONY DUAD C-60 Suitable and the FeCr Position, with DOLBY NR OFF.

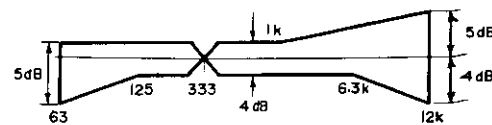

Using SONY DUAD C-60 Suitable and the FeCr Position, with DOLBY NR ON.

11. SCHEMATIC DIAGRAMS P.C. BOARD PATTERNS AND PARTS LIST

NOTE:

When ordering resistors, first covert resistance values into code form as shown in the following examples.

Ex. 1 When there are 2 effective digits (any digit apart from 0), such as 560 ohm and 47k ohm (tolerance is shown by J = 5%, and K = 10%).

560Ω 56 × 10¹ 561 RD¼PS 561 J
 47kΩ 47 × 10³ 473 RD¼PS 473 J
 0.5Ω 0R5 RN2H 0R5 K
 1Ω 010 RSIP 010 K

Ex. 2 When there are 3 effective digits (such as in high precision metal film resistors).

5.62kΩ 562 × 10¹ 5621 RN¼SR 5621 F

11.1 MISCELLANEOUS PARTS LIST

Miscellaneous Parts

Part No.	Symbol & Description
RTT-141 (KU)	Power transformer
RTT-142 (KC)	
RSA-021	Power switch
RWX-234 (KU)	Speark killer
RWX-235 (KC)	
RBM-004	Wire nut
RSN-014	S7 (Chrome tape detector)
RSN-021	S8 (Play)
RSN-013	S9 (FF, REW Muting)
RSN-010	S11 (Motor)
RXM-046	Motor
RWX-228	Dolby assembly
CKDYF 473K 50	C101, C102
RPB-052	REC/P.B. Head
RPB-014	Erase Head
RAW-094	Level meter (CT-F500)
RAW-109	Level meter (CT-F505)

External Appearances of Transistors

2SA826LN
 2SC1327
 2SC1740LN

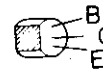

2SC790

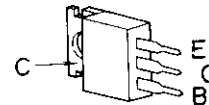

2SD666

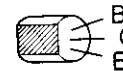

PA4002

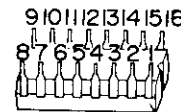

Index

11.2 CONNECTION DIAGRAM

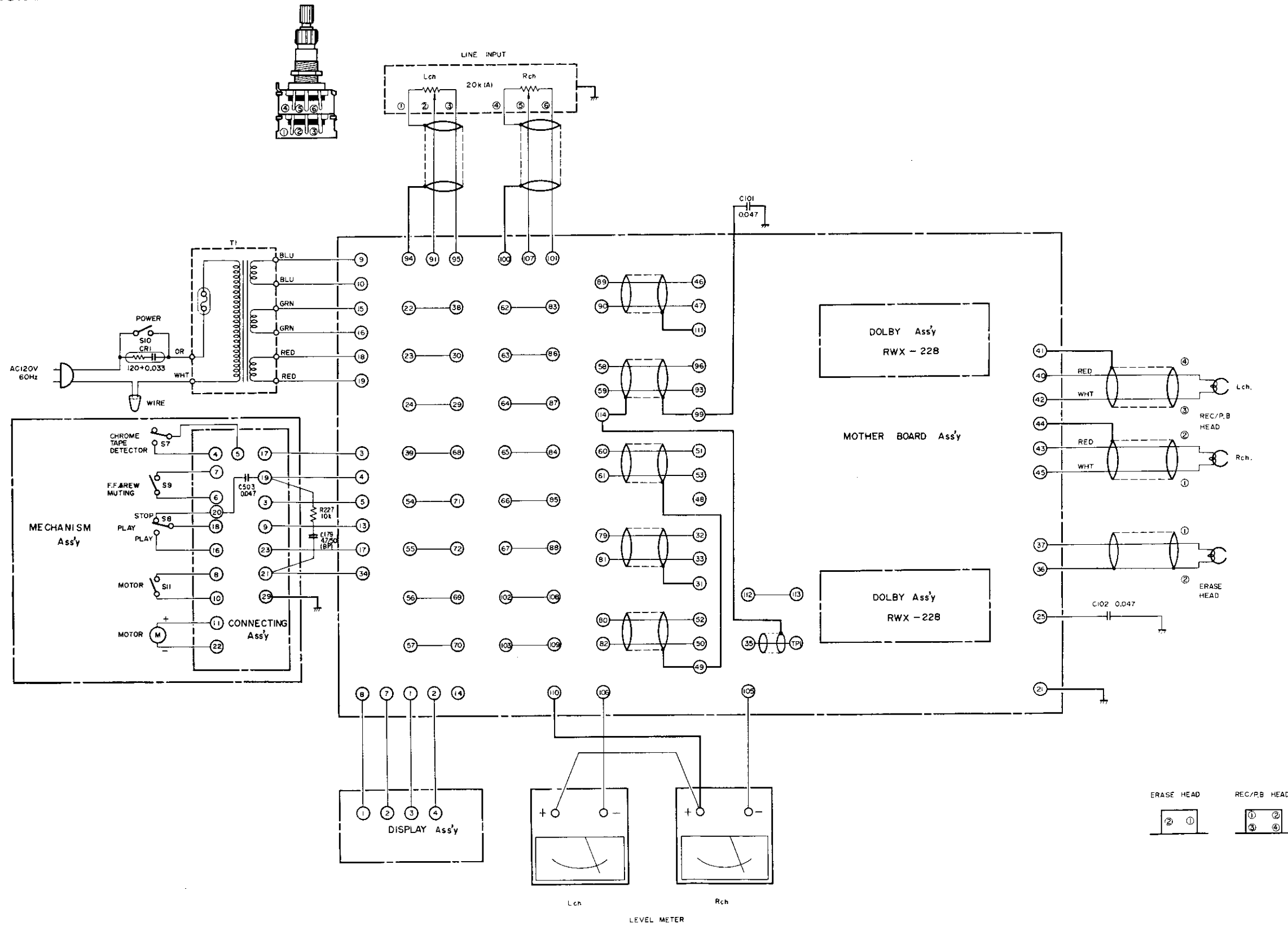

11.3 SCHEMATIC DIAGRAM

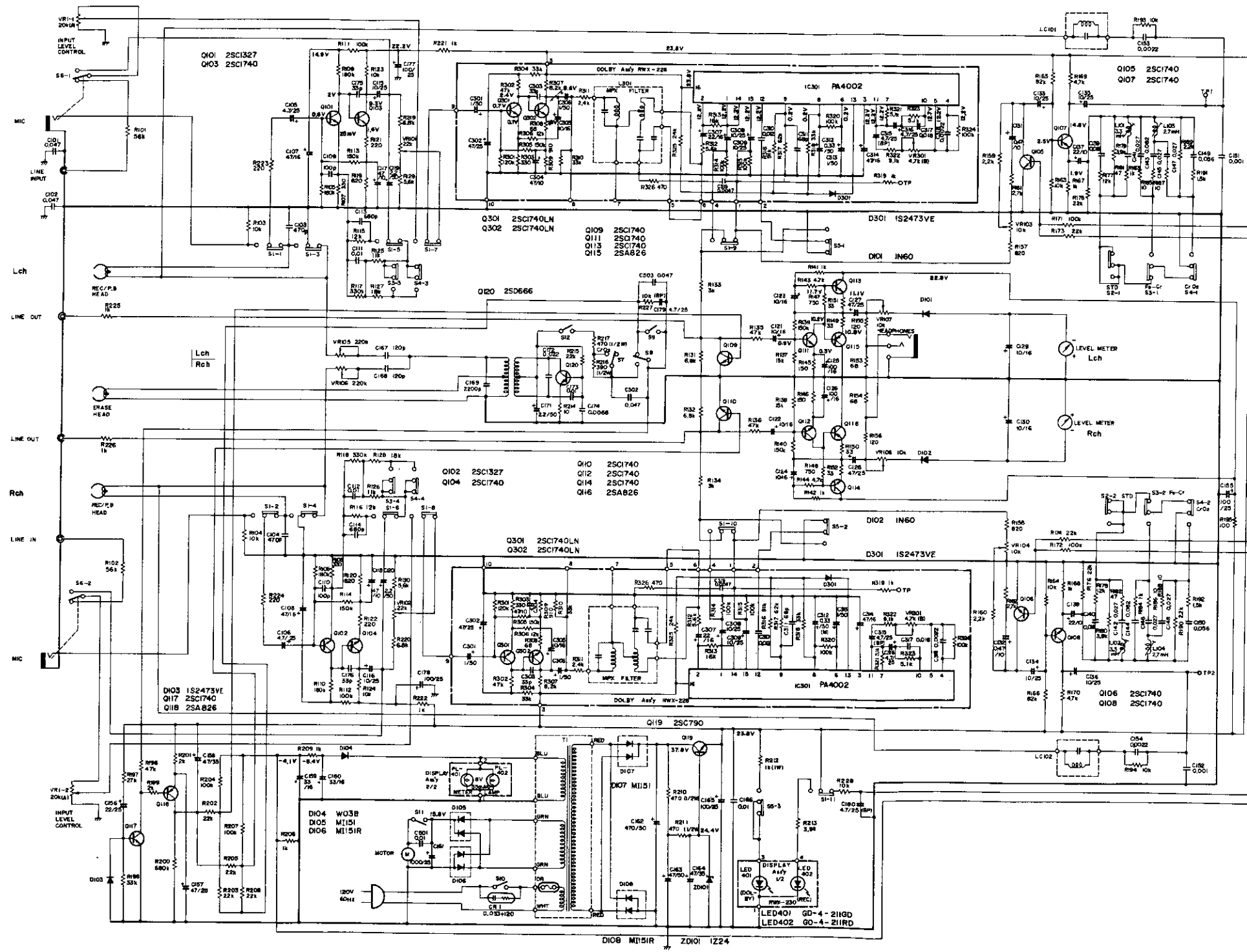

- RESISTORS**
 IN OHM 1/4W 2.5% TOLERANCE UNLESS OTHERWISE NOTED k:1k M:M.M
- CAPACITORS**
 IN μ F UNLESS OTHERWISE NOTED p:pF
- V:DC VOLTAGE AT NO INPUT SIGNAL
- This is the basic schematic diagram, but the actual circuit may vary due to improvements in design.
- SWITCHES**
- S1 REC/P/B SELECTOR REC - PLAYBACK
 - S2 TAPE SELECTOR (STD) ON - OFF
 - S3 TAPE SELECTOR (Fb-Cr) ON - OFF
 - S4 TAPE SELECTOR (Cr-Oe) ON - OFF
 - S5 DOLBY NR ON - OFF
 - S6 MIC/LINE SELECTOR MIC - LINE
 - S7 CHROME TAPE DETECTOR NO HOLE - HOLE
 - S8 PLAY ON - OFF
 - S9 FF & REW MUTING ON - OFF
 - S10 POWER ON - OFF
 - S11 MOTOR ON - OFF
 - S12 BIAS ON - OFF

11.4 P.C. BOARD CONNECTION DIAGRAM

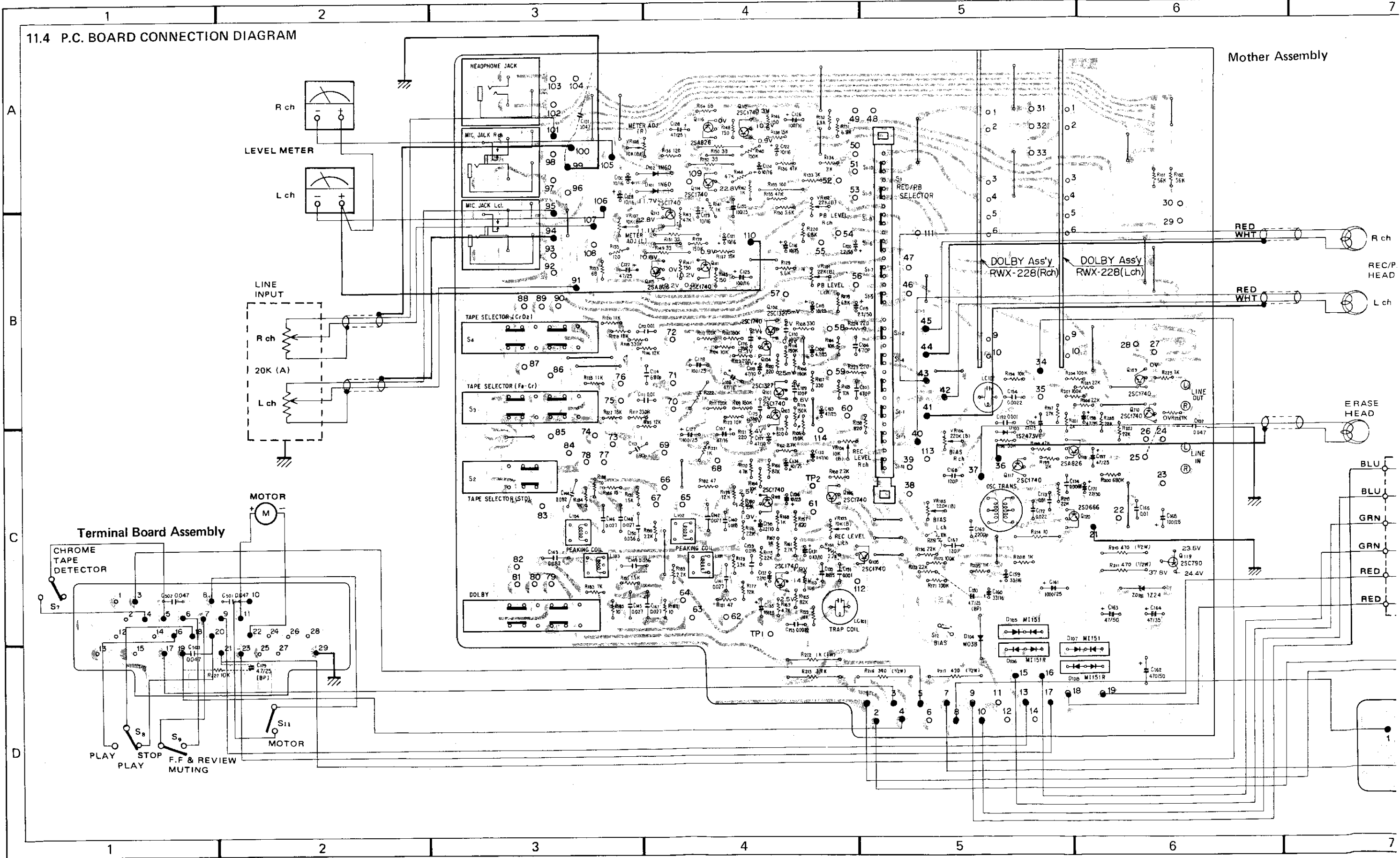

Mother Assembly

Terminal Board Assembly

R ch
REC/P
HEAD

L ch

ERASE
HEAD

BLU
BLU
GRN
GRN
RED
RED

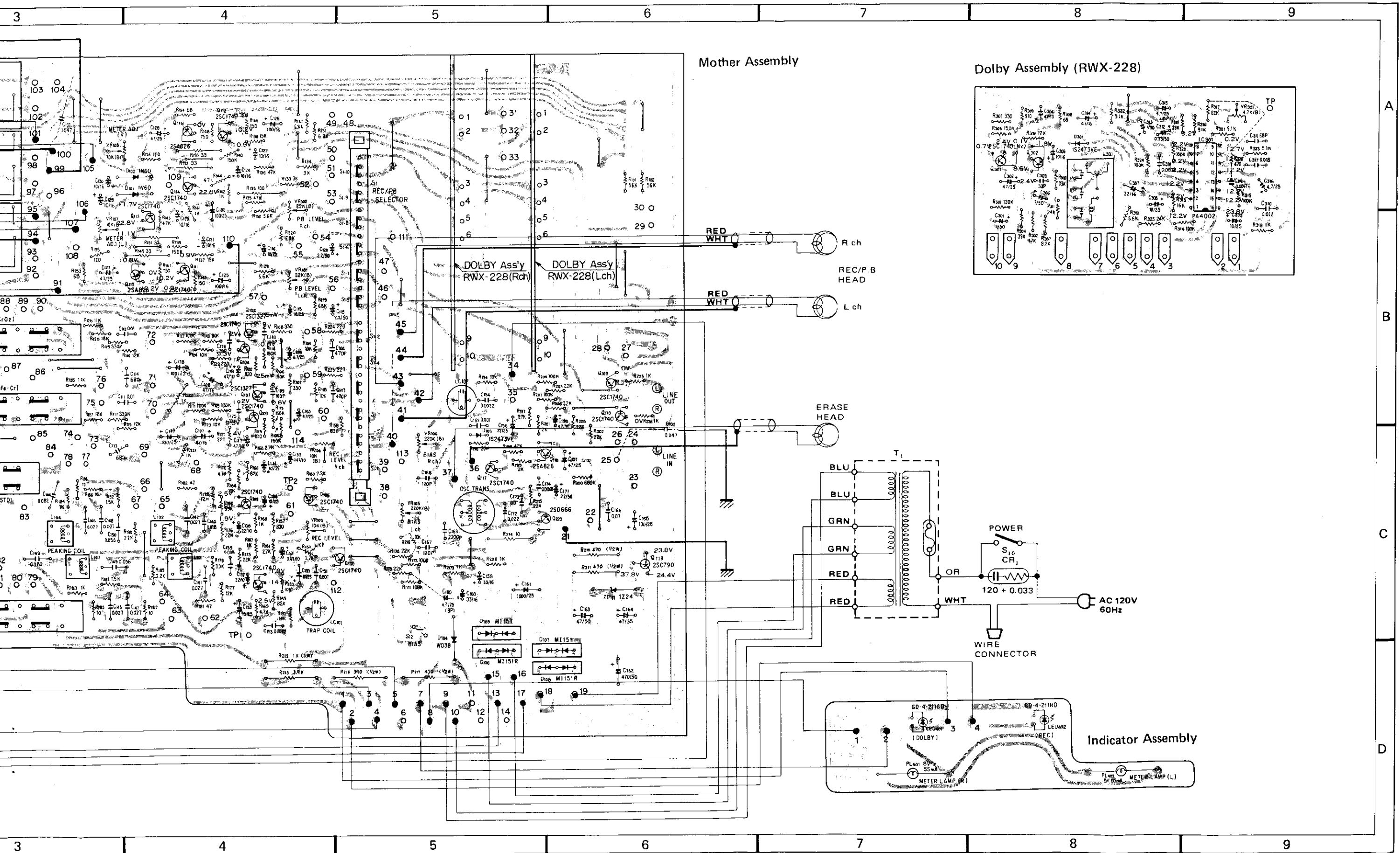

11.5 MOTHER ASSEMBLY

Parts List of Mother A

CAPACITORS

Part No.	Symbol
CKDYF 473Z 50	C101, C
RCE-014	C103, C
CEANL 4R7P 25	C105, C
CEA 470P 16	C107, C
CCDSL 101K 50	C109, C
CQMA 103K 50	C111, C
RCE-021	C113, C
CEA 100P 25	C115, C
CEA 470P 10	C117, C
CEA 2R2P 50	C119, C
CEA 100P 16	C121-C
CEA 101P 16	C125, C
CEA 470P 25	C127, C
CSSA R47M 10	C131, C
CEA 220P 10	C137, C
CQMA 183K 50	C139, C
CQMA 473K 50	C141, C
CQMA 563K 50	C149, C
CQMA 823K 50	C143, C
CQMA 102K 50	C151, C
CQMA 222K 50	C153, C
CEA 101P 25	C155, C
CEA 4R7P 25	C158
CEA 220P 25	C156
CEA 330P 16	C159, C
CEA 102P 25	C161
CEA 471P 50	C162
CEA 470P 50	C163
CEA 470P 35	C164
RCE-009	C167, C
RCE-005	C169
CQMA 223K 50	C172
CQMA 682K 50	C174
CCDSL 330K50	C175, C
RCH-037	C180

Note:

RESISTORS

Part No.	Symbol
C92-857	VR101
C92-049	VR103
RCP-005	VR105
RD¼VS □□□J	R101-
RD¼PSF □□□J	R210,
RS1P 102J	R212
RD¼PS □□□J	R213,

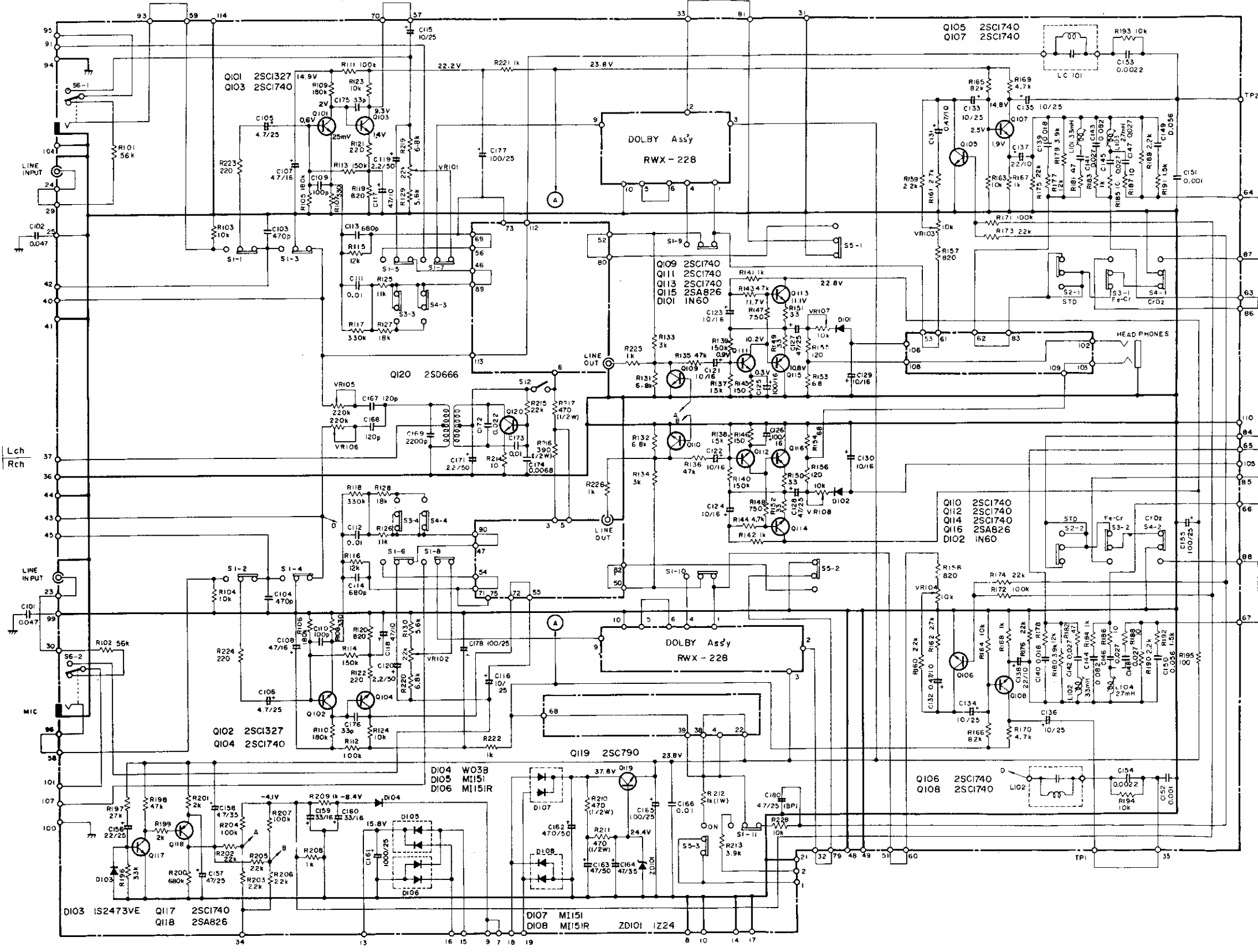

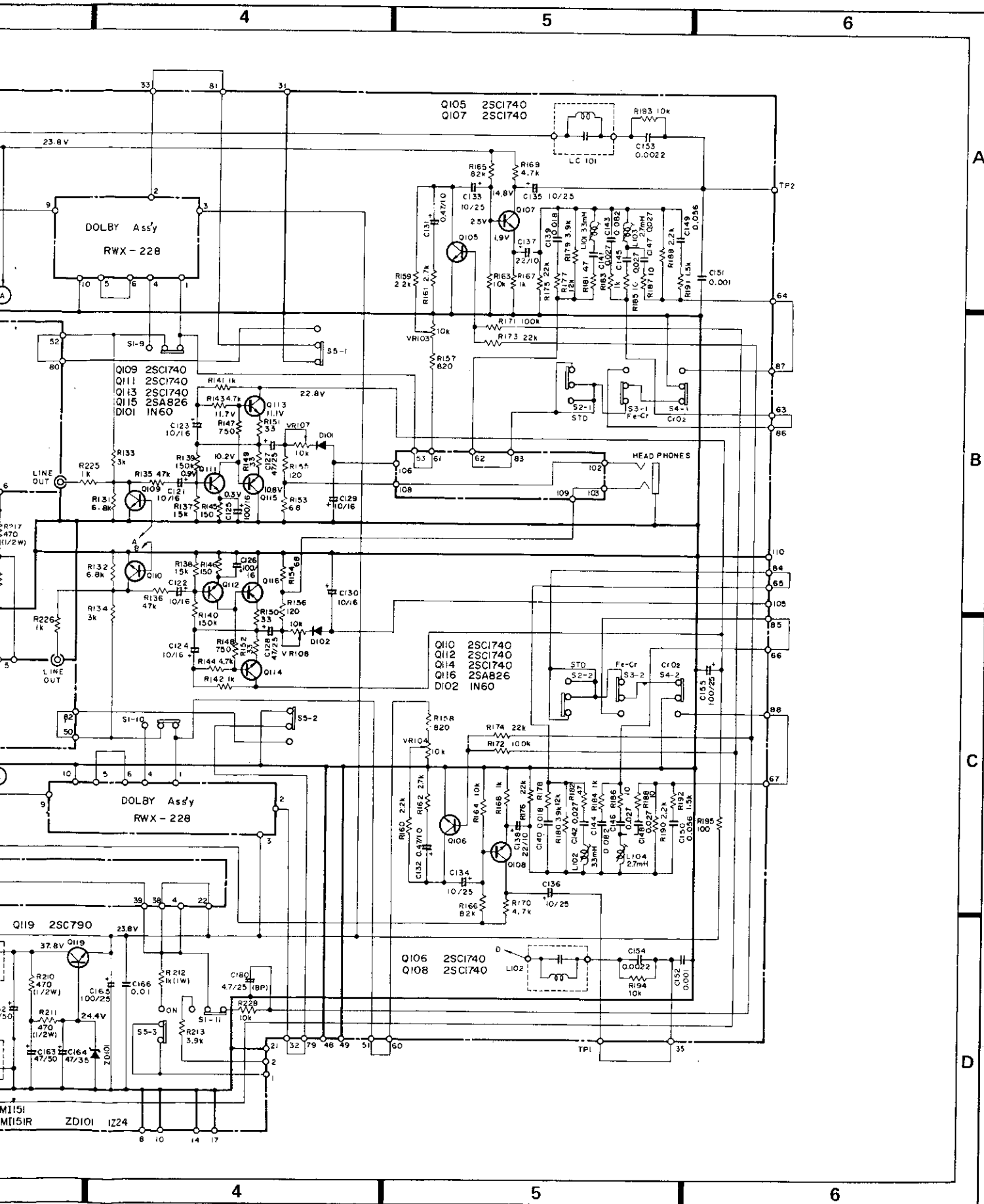

Parts List of Mother Assembly

CAPACITORS

Part No.	Symbol & Description
CKDYF 473Z 50	C101, C102
RCE-014	C103, C104
CEANL 4R7P 25	C105, C106
CEA 470P 16	C107, C108
CCDSL 101K 50	C109, C110
CQMA 103K 50	C111, C112, C166, C173
RCE-021	C113, C114
CEA 100P 25	C115, C116, C133-C136
CEA 470P 10	C117, C118
CEA 2R2P 50	C119, C120, C171
CEA 100P 16	C121-C124, C129, C130
CEA 101P 16	C125, C126
CEA 470P 25	C127, C128, C157
CSSA R47M 10	C131, C132
CEA 220P 10	C137, C138
CQMA 183K 50	C139, C140
CQMA 473K 50	C141, C142, C145-C148
CQMA 563K 50	C149, C150
CQMA 823K 50	C143, C144
CQMA 102K 50	C151, C152
CQMA 222K 50	C153, C154
CEA 101P 25	C155, C165, C177, C178
CEA 4R7P 25	C158
CEA 220P 25	C156
CEA 330P 16	C159, C160
CEA 102P 25	C161
CEA 471P 50	C162
CEA 470P 50	C163
CEA 470P 35	C164
RCE-009	C167, C168
RCE-005	C169
CQMA 223K 50	C172
CQMA 682K 50	C174
CCDSL 330K 50	C175, C176
RCH-037	C180

SEMICONDUCTORS

Part No.	Symbol & Description
2SC1327-T or U	Q101, Q102
2SC1740LN-R or S	Q103-Q114, Q117
2SA826LN-Q or R	Q115, Q116, Q118
2SC790-O or Y	Q119
2SD666-C	Q120
1N60	D101, D102
1S2473VE	D103
W03B	D104
MI-151	D105, D107
MI-151R	D106, D108
IZ-24	ZD101

TRANSFORMERS AND OTHERS

Part No.	Symbol & Description
RTF-046	LC101, LC102
RTF-045	L101, L102
RTF-047	L103, L104
RSG-062	Push switch
RSN-018	Reef switch
RSH-037	Slide switch
RKB-014	Pinjack assembly (4P)
RKN-047	Mic jack
RKN-048	Phone jack

RESISTORS

Part No.	Symbol & Description
C92-857	VR101, VR102 22k-B
C92-049	VR103, VR104, VR107, VR108 10k-B
RCP-005	VR105, VR106 220k-B
RD%VS □□□ J	R101-R209, R214, R215, R221, R222
RD%PSF □□□ J	R210, R211, R217, R216
RS1P 102J	R212
RD%PS □□□ J	R213, R228

Note: When ordering resistors, convert the resistance value into code form, and then rewrite the part no. as before.

RESISTANCE VALUE CODES

Code numbers of resistors used in Pioneer equipment are expressed in the following way:—

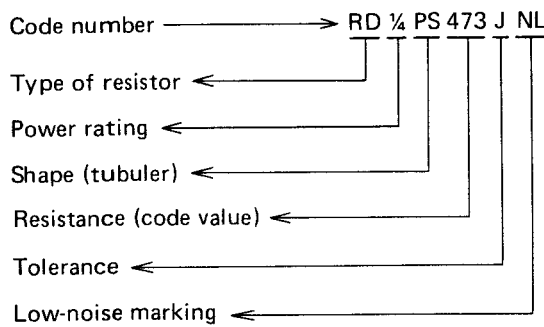

Furthermore, in the list of parts found in the Service Manual, the resistance (code value) part of the above code number is expressed as □□□ or □□□□.

Resistors included in the Service Manual list of parts

Ex. RD 1/4 PS □□□ JNL

When ordering resistor components, first ascertain the actual resistance value from the circuit diagram, and then convert it into code no. form as shown in the following examples.

For further details on code numbers, refer to "Tuning Fork" VOL. 1.

Ex. 1 For □□□□ Codes

* General resistors

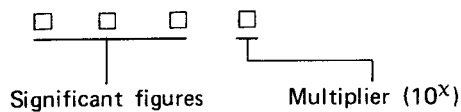

* Resistors with fractional values

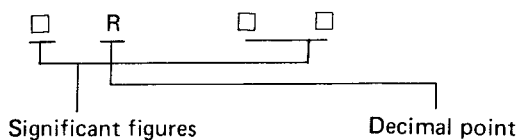
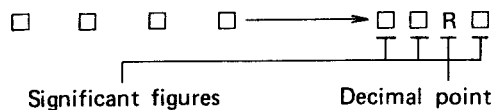

Ex. 1

Nominal resistance (Ω)	Significant figure (three figures)	Multiplier (10 ^X)	Resistance value code
5.1	510	5R10
5.62	562	5R62
10	100	10R0
22.5	225	22R5
110	110	x10 ⁰	1100
1k (1000)	100	x10 ¹	1001
1.56k (1560)	156	x10 ¹	1561
10k (10000)	100	x10 ²	1002
33.6k (33600)	336	x10 ²	3362
112k (112000)	112	x10 ³	1123
1M (1000000)	100	x10 ⁴	1004
1.56M (1560000)	156	x10 ⁴	1564

Ex. 2 For □□□ Codes

* General resistors

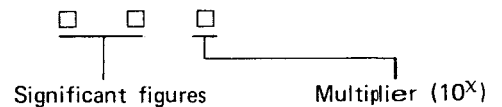

* Resistors with fractional values



Ex. 2

Nominal resistance (Ω)	Significant figure (two figures)	Multiplier (10 ^X)	Resistance value code
0.5	05	0R5
1.5	15	1R5
1	01	x10 ⁰	010
22	22	x10 ⁰	220
330	33	x10 ¹	331
1k (1000)	10	x10 ²	102
5.6k (5600)	56	x10 ³	562
68k (68000)	68	x10 ³	683
820k (820000)	82	x10 ⁴	824
1M (1000000)	10	x10 ⁵	105
2.2M (2200000)	22	x10 ⁵	225

11.6 DOLBY ASSEMBLY (RWX-228)

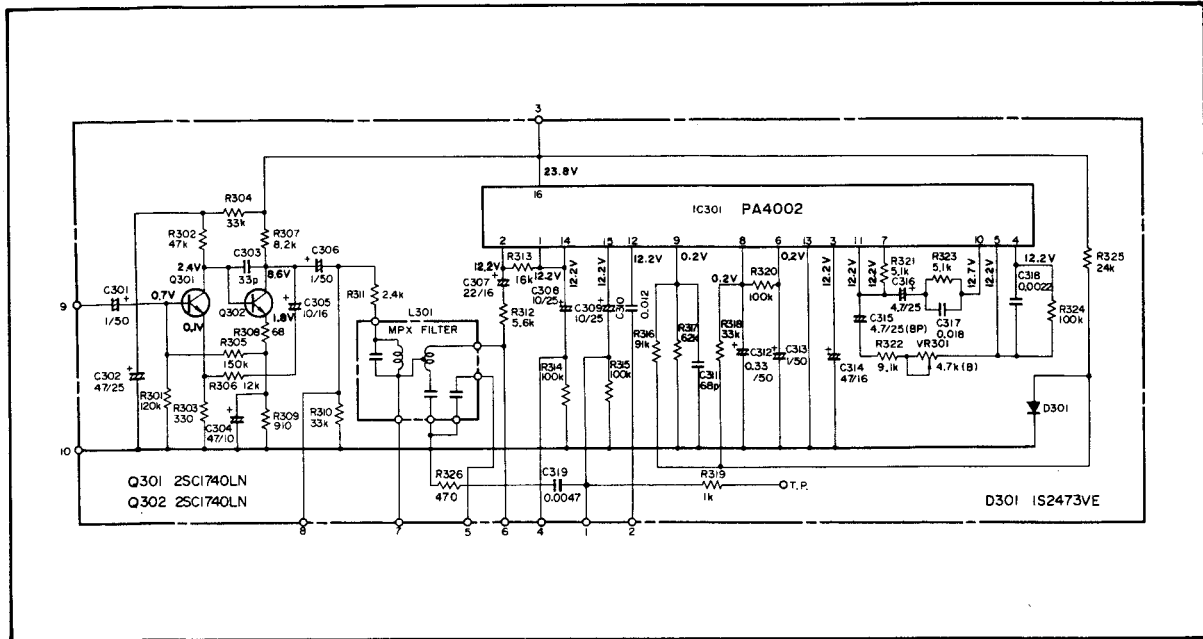

Parts List of Dolby Assembly (RWX-228)

CAPACITORS

Part No.	Symbol & Description
CEA 010P 50	C301, C306
CEA 470P 25	C302
CCDSL 330K 50	C303
CEA 470P 10	C304
CEA 100P 16	C305
CEA 220P 16	C307
CEA 100P 25	C308, C309
CQMA 123K 50	C310
CCDSL 680K 50	C311
CEAKA R33M 50	C312
CEA 010M 50	C313
CEA 470P 16	C314
RCH-037	C315
CEA 4R7P 25	C316
CQMA 183K 50	C317
CQMA 222K 50	C318

Note: When ordering resistors, convert the resistance value into code form, and then rewrite the part no. as before.

RESISTORS

Part No.	Symbol & Description
RD $\frac{1}{4}$ VS □□□ J	R301-R325
RCP-038	VR301 4.7k-B

SEMICONDUCTORS AND COILS

Part No.	Symbol & Description
PA4002	IC301
2SC1740LN-R or S	Q301, Q302
IS2473VE	D301
RTF-040	L301

11.7 INDICATOR ASSEMBLY

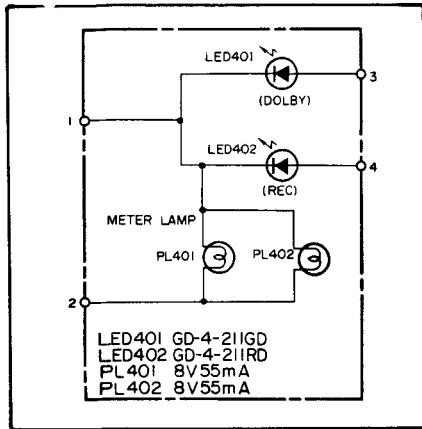

Part List of Indicator Assembly

Part No.	Symbol & Description
GD-4-211RD	LED402
GD-4-211GD	LED401
REL-061	PL401, PL402
RNK-521	LED holder
REB-274	Lamp mount

11.8 TERMINAL BOARD ASSEMBLY

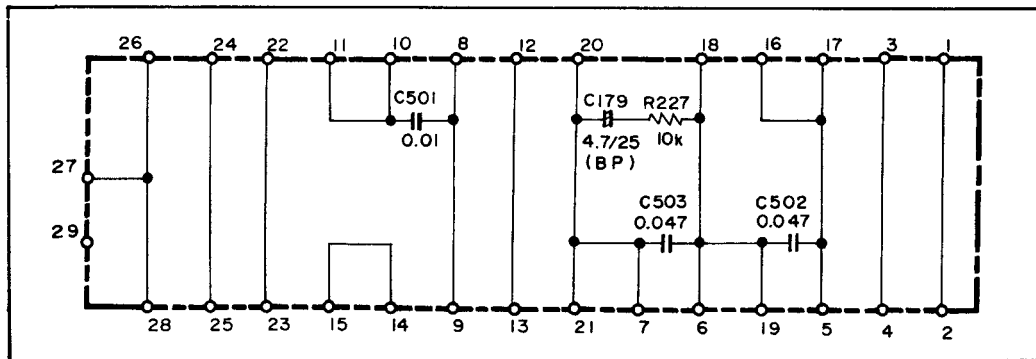

Part List of Terminal Board Assembly

Part No.	Symbol & Description
CKDYF 103Z 50	C501
CKDYF 473Z 50	C502, C503
RCH-037	C179
RD¼PS 103J	R227

12. EXPLODED

12.1 BONNET and BOTTOM COVER

NOTE:

 marked parts cannot be supplied.

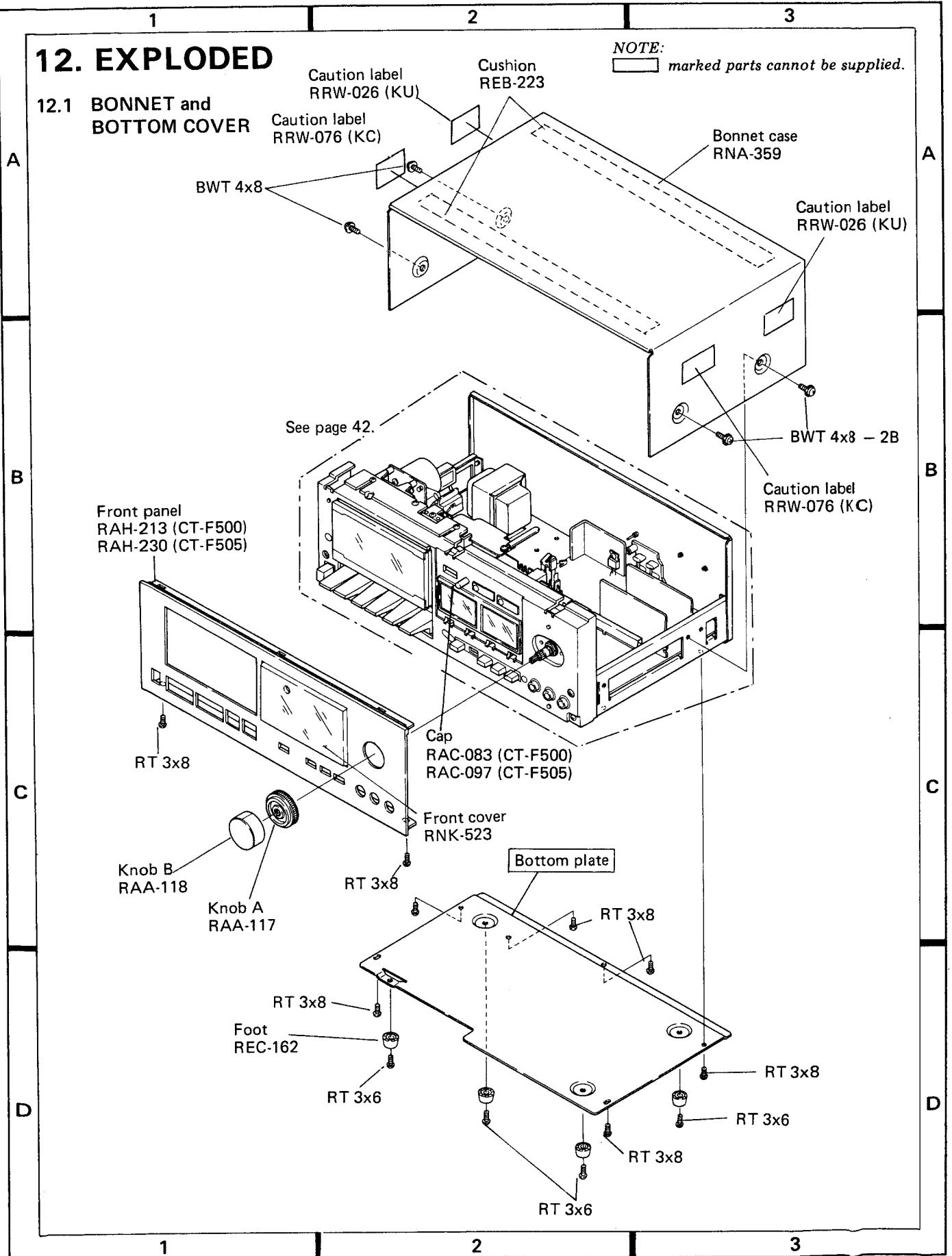

12.3 CHASSIS

NOTE:  marked parts cannot be supplied.

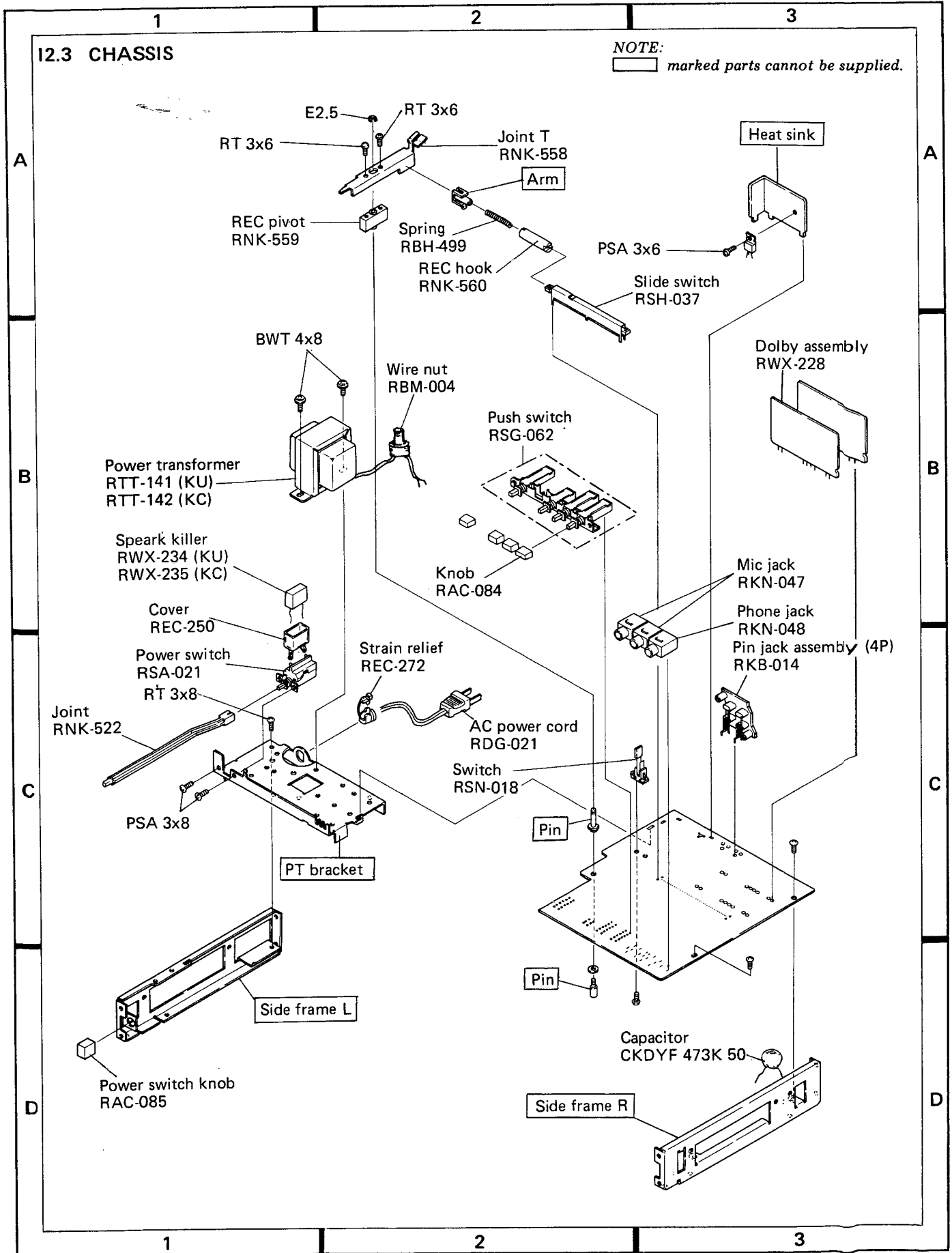

12.4 DOOR

NOTE: marked parts cannot be supplied.

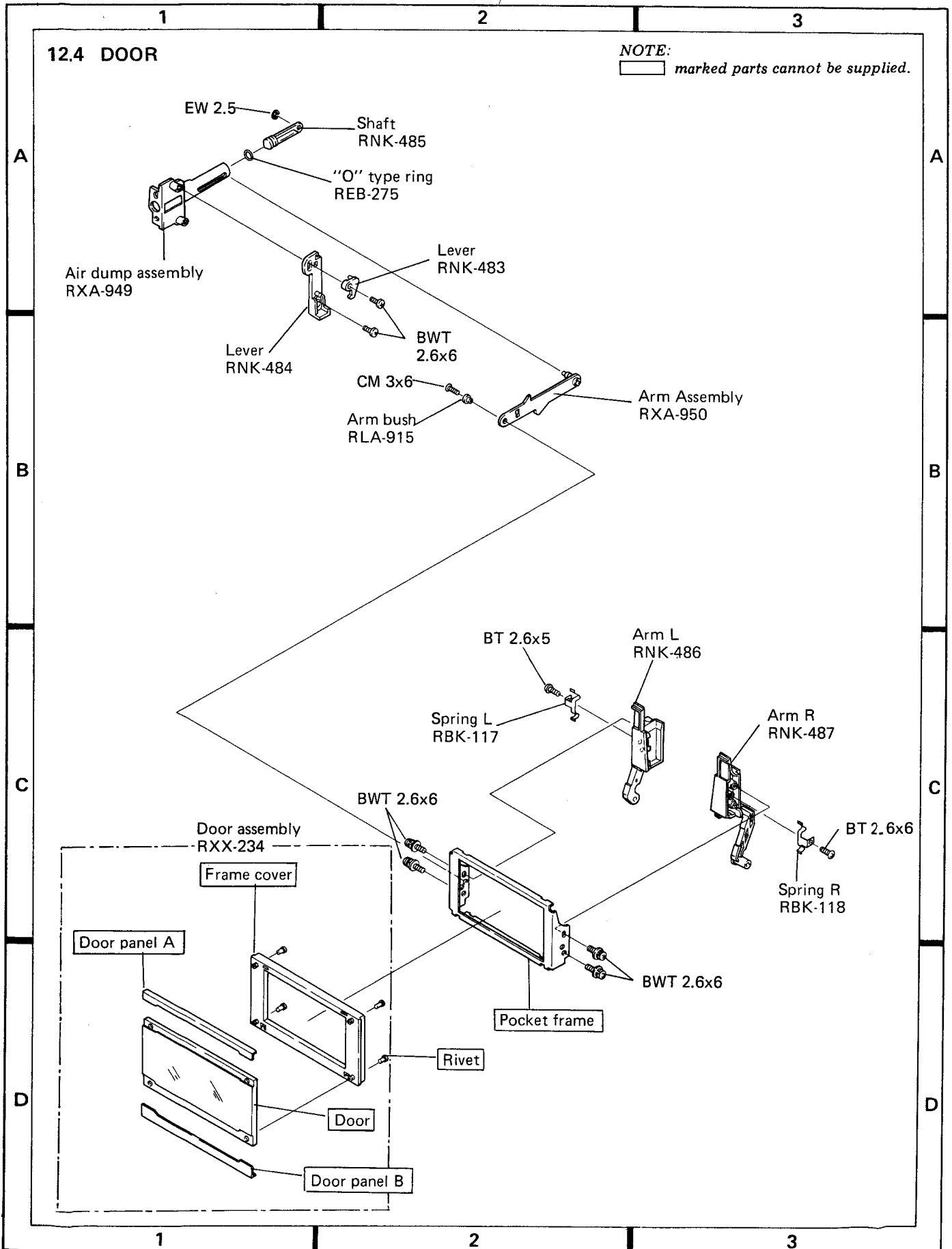

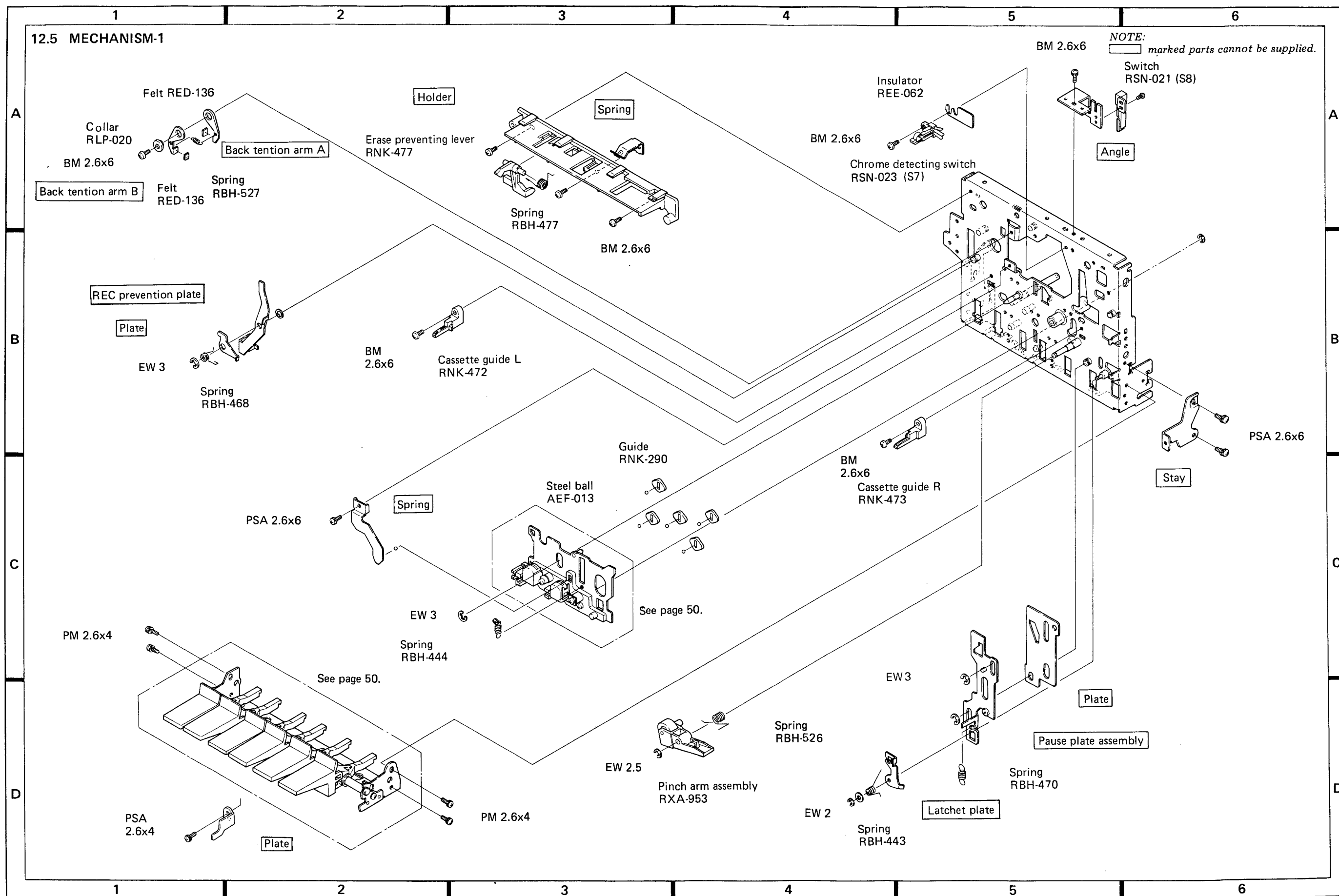

12.7 PULLEY and IDLER

NOTE: marked parts cannot be supplied.

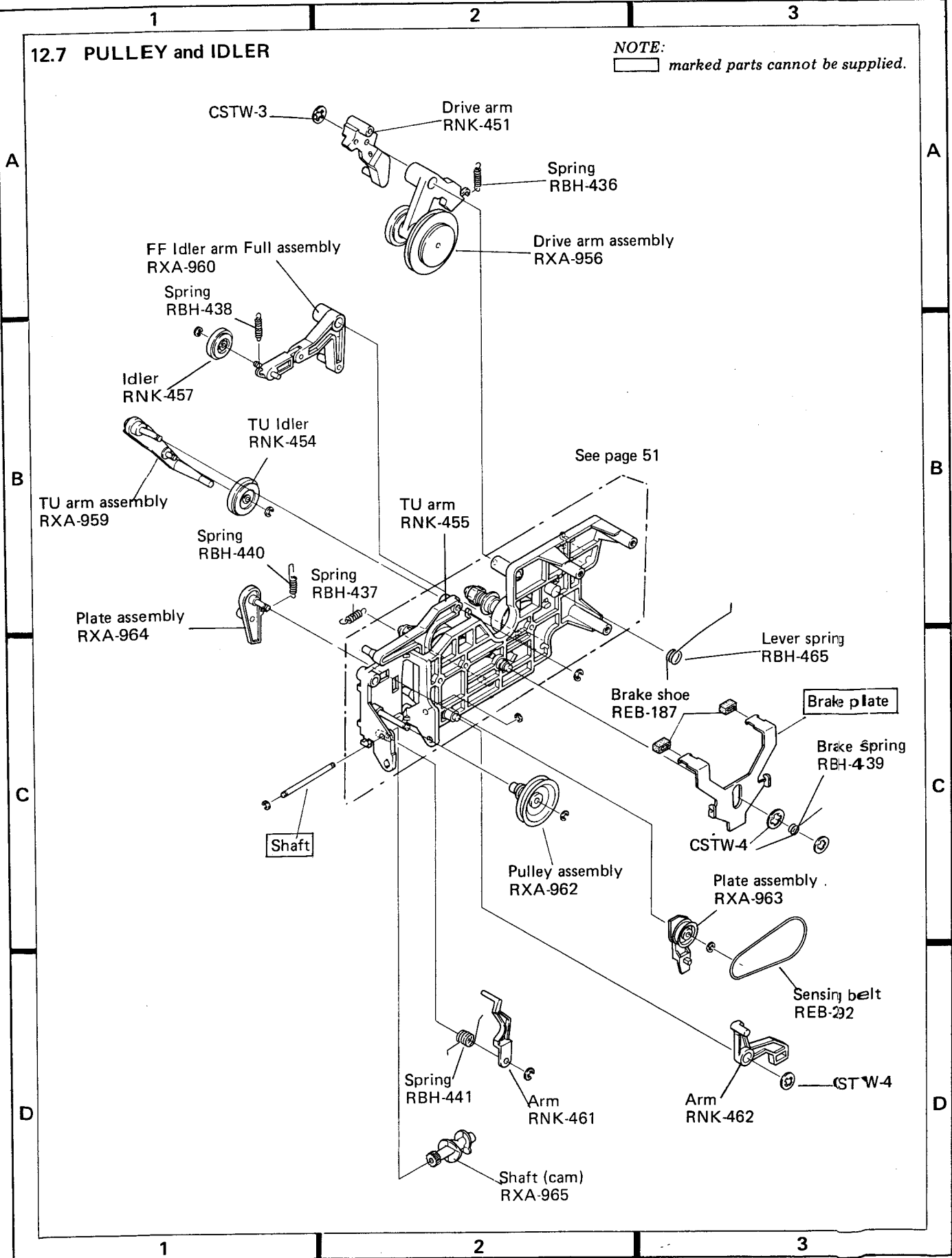

12.8 BUTTON

NOTE: marked parts cannot be supplied.

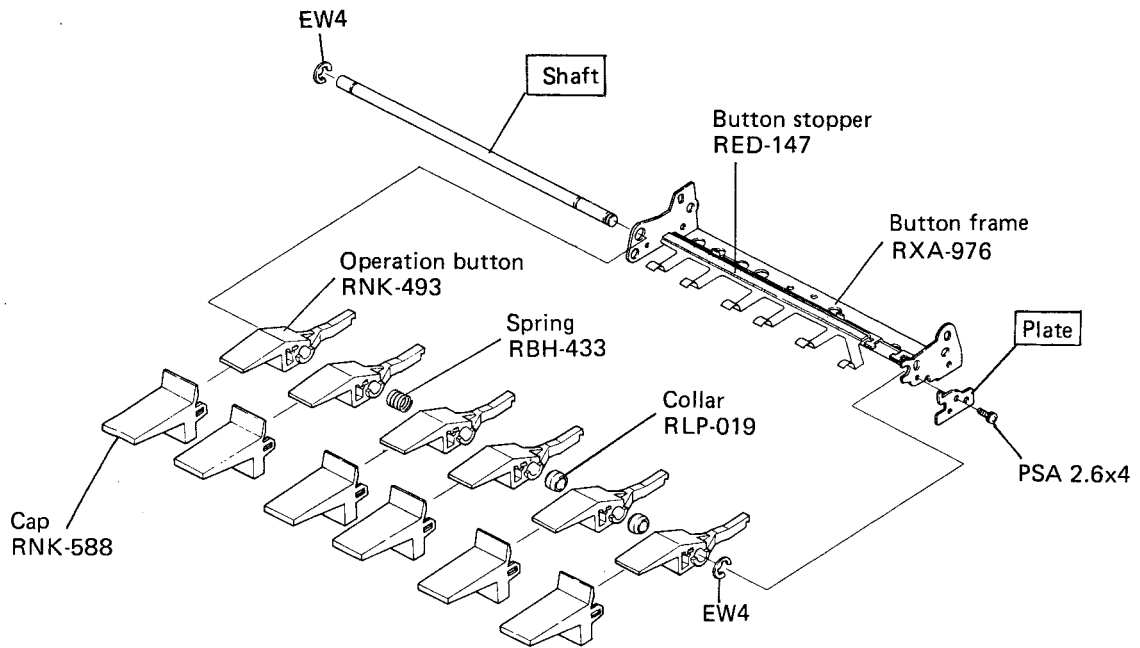

12.9 HEAD BASE

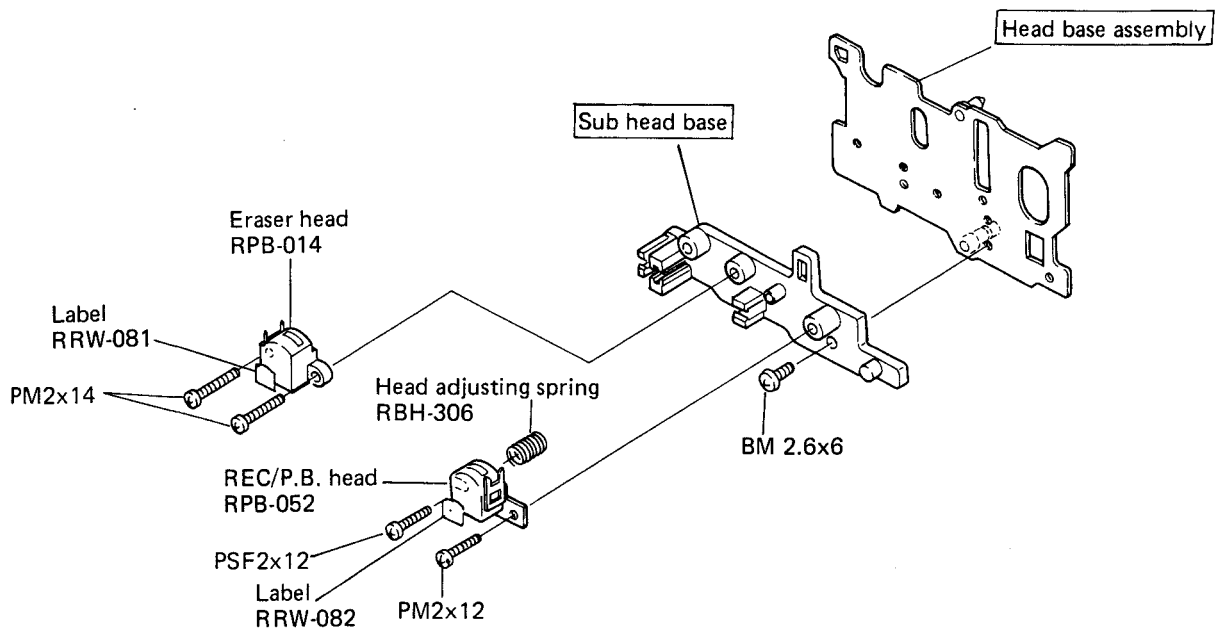

12.10 REEL BASE

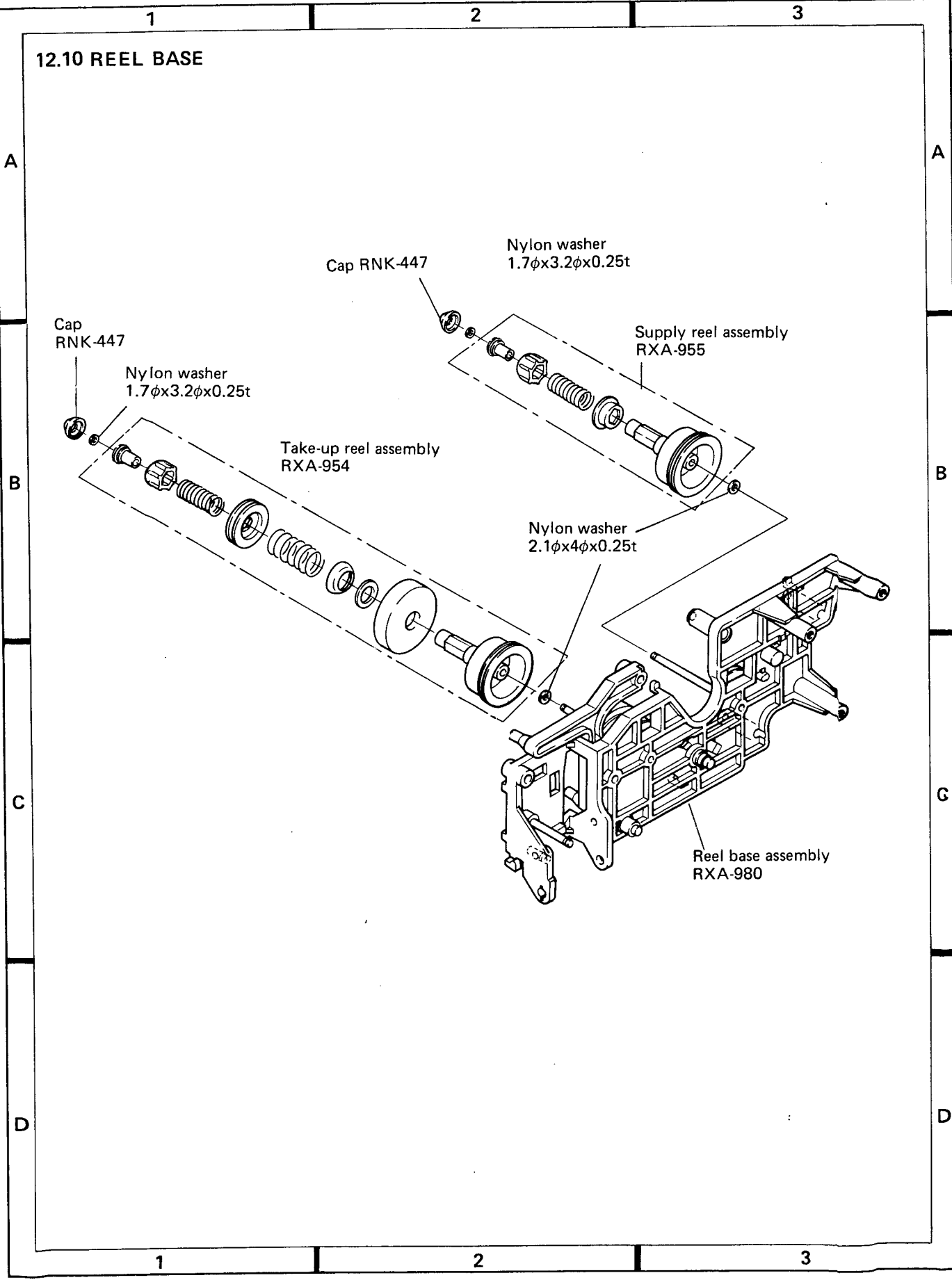

13. PACKING

