

Service Manual

PIONEER
The Art of Entertainment

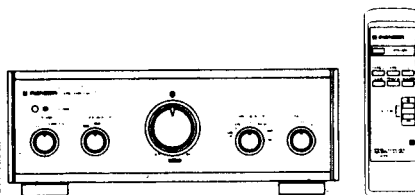

ORDER NO.
ARP2895

STEREO AMPLIFIER

A-07

THIS MANUAL IS APPLICABLE TO THE FOLLOWING MODEL(S) AND TYPE(S).

Type	Model	Power Requirement	Remarks
MEZ	○	AC 220V - 230V	

CONTENTS

1. EXPLODED VIEWS, PACKING AND PARTS LIST	2
2. SCHEMATIC AND PCB CONNECTION DIAGRAMS	8
3. PCB PARTS LIST	19
4. BLOCK DIAGRAM	23
5. ADJUSTMENTS	24
6. PANEL FACILITIES	25
7. SPECIFICATIONS	26

PIONEER ELECTRONIC CORPORATION 4-1, Meguro 1-Chome, Meguro-ku, Tokyo 153, Japan
PIONEER ELECTRONICS SERVICE INC. PO Box 1760, Long Beach, CA 90801-1760, U.S.A.
PIONEER ELECTRONIC [EUROPE] N.V. Haven 1087, Keetberglaan 1, 9120 Melsele, Belgium
PIONEER ELECTRONICS ASIACENTRE PTE. LTD. 501 Orchard Road, #10-00 Lane Crawford Place, Singapore 0923
© PIONEER ELECTRONIC CORPORATION 1995

O-FFC MAY. 1995 Printed in Japan

1. EXPLODED VIEWS, PACKING AND PARTS LIST

NOTES:

- Parts marked by "NSP" are generally unavailable because they are not in our Master Spare Parts List.
- The Δ mark found on some component parts indicates the importance of the safety factor of the part. Therefore, when replacing, be sure to use parts of identical designation.
- Parts marked by "☉" are not always kept in stock. Their delivery time may be longer than usual or they may be unavailable.

1.1 PARTS LIST

Mark	No.	Description	Parts No.	Mark	No.	Description	Parts No.
Δ	1	Q1 TRANSISTOR	2SC3281	NSP	46	AC COAD SPACER	ANG1979
Δ	2	Q2 TRANSISTOR	2SC3281		47	LONG SYAFT	ANL7001
Δ	3	Q3 TRANSISTOR	2SA1302	NSP	48	AC CORD HOLDER	AEB1200
Δ	4	Q4 TRANSISTOR	2SA1302	NSP	49	RUBBER STOPPER	AEB1325
Δ	5	Q5 TRANSISTOR	2SC4137		50	NYLON BINDER	AEC-093
Δ	6	Q6 TRANSISTOR	2SC4137	NSP	51	COVER	AEC-294
Δ	7	Q7 TRANSISTOR	2SC4137	NSP	52	PCB HOLDER	AEC1097
Δ	8	Q8 TRANSISTOR	2SC4137	NSP	53	PCB SPACER	AEC1180
Δ	9	D1 DIODE	C16P20F	NSP	54	BUSH (PLS)	AEC1293
Δ	10	D2 DIODE	C16P20F	NSP	55	WIRE CLIP	AEC1388
Δ	11	D3 DIODE	C16P20FR	NSP	56	AC CORD CATCHER	AEC1397
Δ	12	D4 DIODE	C16P20FR		57	PCB CONNECTOR (PVC)	AEC1500
	13	C1 ELECTROLYTIC CAPACITOR	ACH7024		58	EDGE SADDLE	AEC1571
	14	C2 ELECTROLYTIC CAPACITOR	ACH7024		59	DENKA SHEET	AEC1598
	15	C3 ELECTROLYTIC CAPACITOR	ACH7025	NSP	60	SPACER	AEC1601
	16	C4 ELECTROLYTIC CAPACITOR	ACH7026	NSP	61	BUSH (PLS)	AEC1602
Δ	17	C5 CAPACITOR (0.01/AC400V)	ACG1003	NSP	62	BUSH (PLS)	AEC1603
Δ	18	C6 CAPACITOR (0.01/AC400V)	ACG1003	NSP	63	SPACER	AEC1430
Δ	19	T1 POWER TRANSFORMER	ATS7071		64	HOLDER	AEC1534
Δ	20	T2 POWER TRANSFORMER	ATS7071	NSP	65	FRAME	ANK7015
Δ	21	RY1 POWER RELAY (12V)	ASR1041		66	FRONT PANEL	ANB7016
Δ	22	RY2 POWER RELAY (12V)	ASR1041		67	INDICATOR LENS	AAK2303
	23	GROUND TERMINAL	AKE-046		68	SIDE PANEL	AMR2606
	24	1P SPEAKER TERMINAL	AKE7009		69	SIDE PANEL	AMR2607
	25	1P SPEAKER TERMINAL	AKE7010		70	SIDE PANEL	AAP7015
	26	SHORT PIN PLUG	AKM-050		71	ESCUTCHEON A	AMR7048
Δ	27	FU1 FUSE (T1.6A,250V)	AEK-510		72	ESCUTCHEON B	AMR2701
Δ	28	FU2 FUSE (T1.6A,250V)	AEK-510		73	NAME PLATE	VAM1051
Δ	29	FU3 FUSE (T250mA,250V)	AEK-503		74	ROTARY KNOB L	AAAB7056
Δ	30	FU4 FUSE (T500mA,250V)	AEK-505		75	ROTARY KNOB M	AAAB7057
Δ	31	AC POWER CORD	ADG1093		76	REMOCON WINDOW	AAK2457
NSP	32	SIDE FRAME	ANA1218	NSP	77	BONNET CASE	ANE7063
	33	TRANS FRAME	ANA7022		78	SCREW (STEEL)	ABA1011
NSP	34	ANGUL	ANA7023		79	SCREW	ABA-298
	35	REAR PANEL (MET)	ANC7238		80	SCREW (STEEL)	ABA1004
	36	PANEL STAY (MET)	AND7002		81	SCREW (STEEL)	ABA1007
NSP	37	BOTTOM PLATE (MET)	ANF7003		82	BINDER	AEP-215
NSP	38	HEAT SINK	ANH7017		83	SCREW (STEEL)	ABA1053
	39	FOOT	AMR1159		84	SCREW	ABA1024
NSP	40	AC CORD COVER	ANG7034		85	SCREW (STEEL)	ABA1047
NSP	41	VOLUME HOLDER	ANG1661		86	SCREW (STEEL)	ABA1050
	42	WASHER (COPPER)	ABE1001		87	SCREW	ABA1066
	43	EARTH PLATE	ANG1968		88	SCREW	ABA1156
NSP	44	HEATSINK HOLDER (MET)	ANG7033		89	SCREW (STEEL)	ABA1192
	45	BINDER	AEC-826		90	SCREW (STEEL)	ABA1193

Mark	No.	Description	Parts No.	Mark	No.	Description	Parts No.
	91	SCREW (STEEL)	ABA1194	NSP	145	FUSE LABEL	AAK1585
	92	SCREW (STEEL)	ABA1208	NSP	146	FUSE LABEL	AAK1573
	93	SCREW 4×6 (FE)	ABA7011	NSP	147	FUSE LABEL	AAK1582
	94	SAPORT POST	ABA1214				
	95	SCREW	BBZ40P120FZK				
	96	SCREW	IPZ30P120FCU				
NSP	97	SPACER	AEE1013				
	98	NUT	NK70FCU				
	99	NUT	NK90FCU				
	100	SH SCREW	PBA1049				
	101	SCREW	VCZ30P060FMC				
	102	SCREW	VMZ30P060FCU				
	103	WASHER	WC060FUC				
	104	WASHER	WH50FMC				
	105	INPUT L ASSY	AWZ5958				
	106	INPUT R ASSY	AWZ5959				
	107	MOTOR FUNCTION ASSY	AWZ5897				
	108	GAIN SEL ASSY	AWZ5960				
	109	LED ASSY	AWZ5740				
	110	POWER SW ASSY	AWZ5961				
	111	MOTHER ASSY	AWZ5965				
	112	DIODE L ASSY	AWZ5963				
	113	DIODE R ASSY	AWZ5964				
	114	AC ASSY	AWZ5966				
	115	SUB TRANS 1 ASSY	AWZ5957				
	116	PCB SPACER	AEC7020				
	117	SCREW (STEEL)	ABA1006				
	118	MOTOR VOL ASSY	AWZ5896				
	119	M-CON ASSY	AWZ5898				
	120	REC SEL ASSY	AWZ5899				
	121	EYE ASSY	AWZ5730				
	122	SUB TRANS 2 ASSY	AWZ5731				
△	123	R1 CARBON FILM RESISTOR	RD1/4PMF4R7J				
△	124	R2 CARBON FILM RESISTOR	RD1/4PMF4R7J				
	125	C7 POLYESTER CAPACITOR	CQMXA472J100				
	126	C8 POLYESTER CAPACITOR	CQMXA472J100				
	127	C9 POLYESTER CAPACITOR	CQMXA472J100				
	128	C10 POLYESTER CAPACITOR	CQMXA472J100				
	129	J1 3P WIRE 250	ADX2150				
	130	J2 3P WIRE 250	ADX2150				
	131	Y27 LEAD WIRE	ADX2166				
	132	SHEET	AEE1014				
	133	HOLDER	AMR1178				
	134	INSTRUCTION MANUAL (English/German/French/Italian/ Swedish/Dutch/Spanish/Portuguese)	ARE7053				
	135	SIDE PAD R	AHA2042				
	136	SIDE PAD L	AHA2043				
	137	PACKING CASE	AHD7181				
NSP	138	PACKING SHEET	AHG1163				
NSP	139	WARRANTY CARD	ARW-088				
	140	REMO-CON (CU-A017)	AXD7060				
NSP	141	BATTERY (R03, AAA)	AEX-021				
NSP	142	VINYL POUCH	AHG-027				
NSP	143	LITERATURE BAG	AHG-117				
	144	BATTERY COVOR	AZN7234				

1.2 PACKING

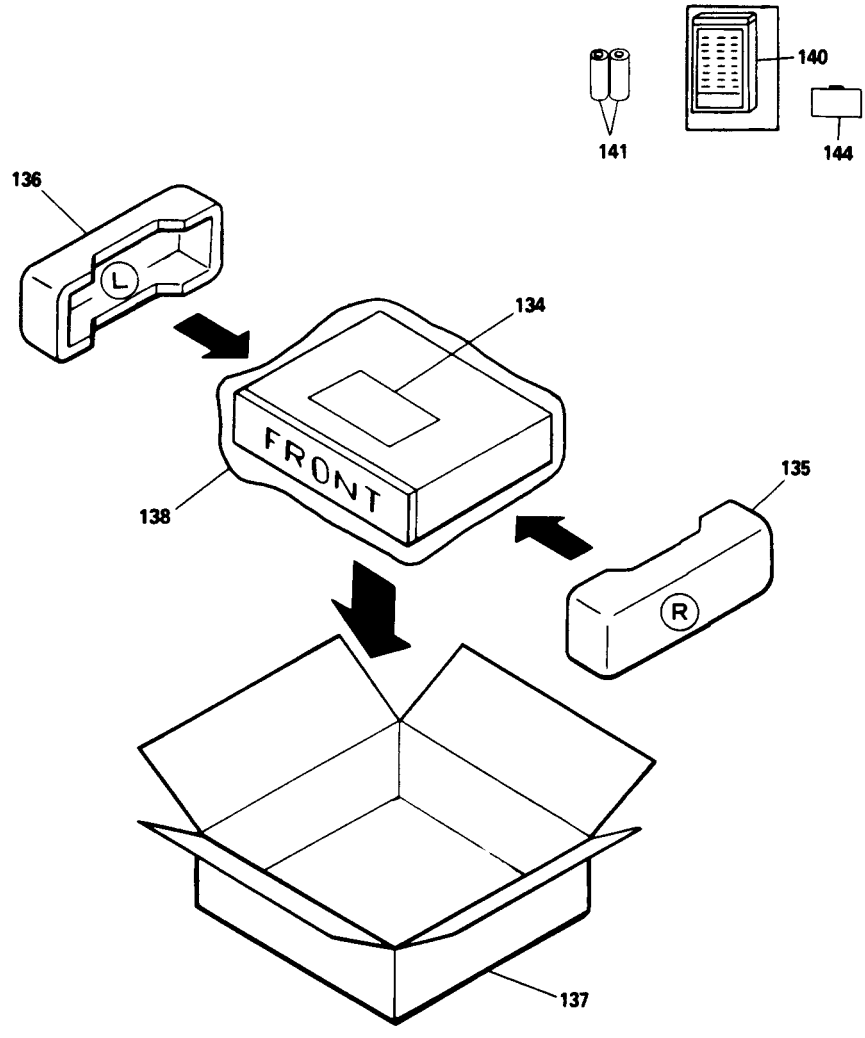

A

B

C

D

E

F

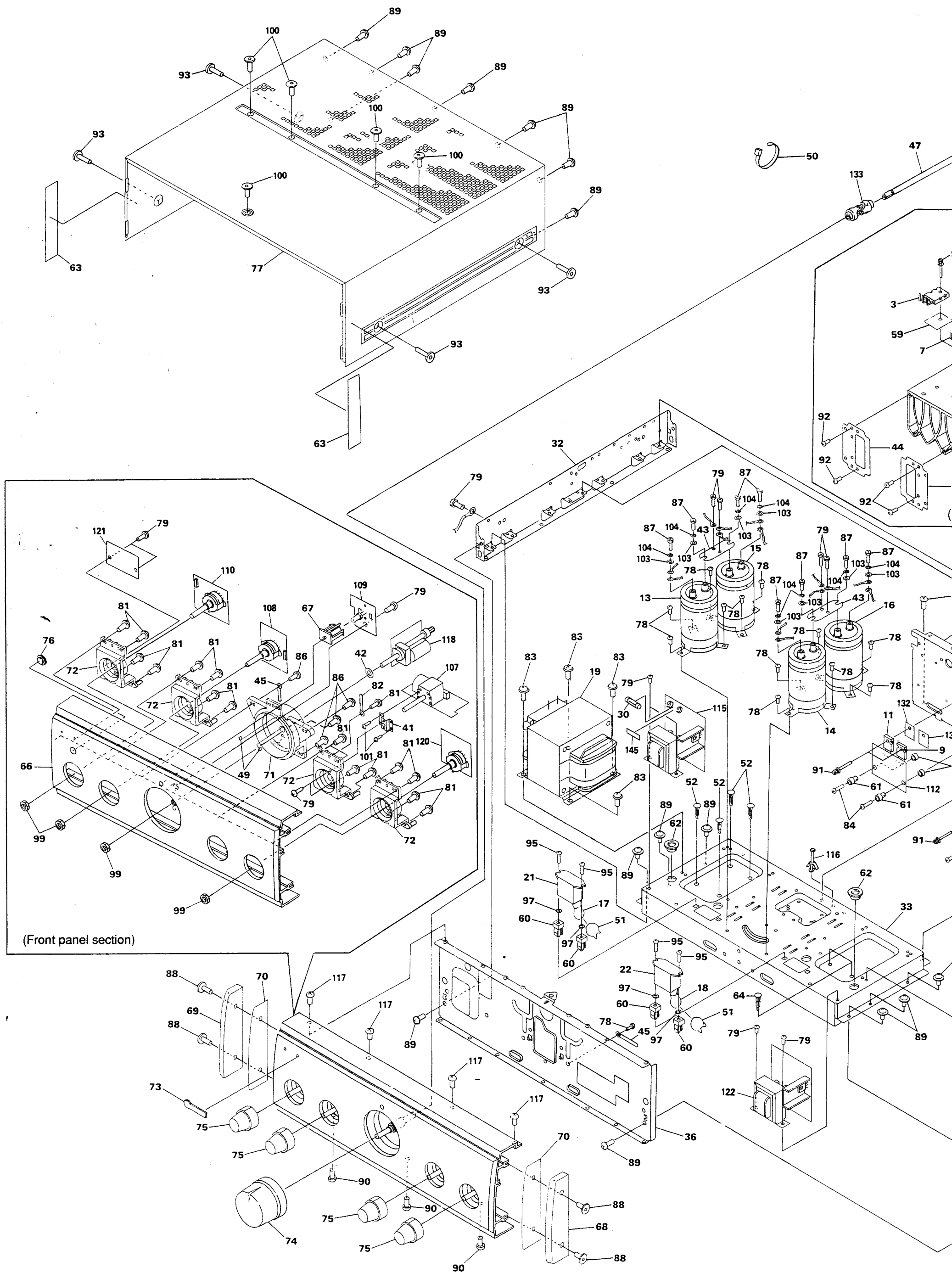

(Front panel section)

NOTE : Screws adjacent to ▼ mark on are used for disassembly.

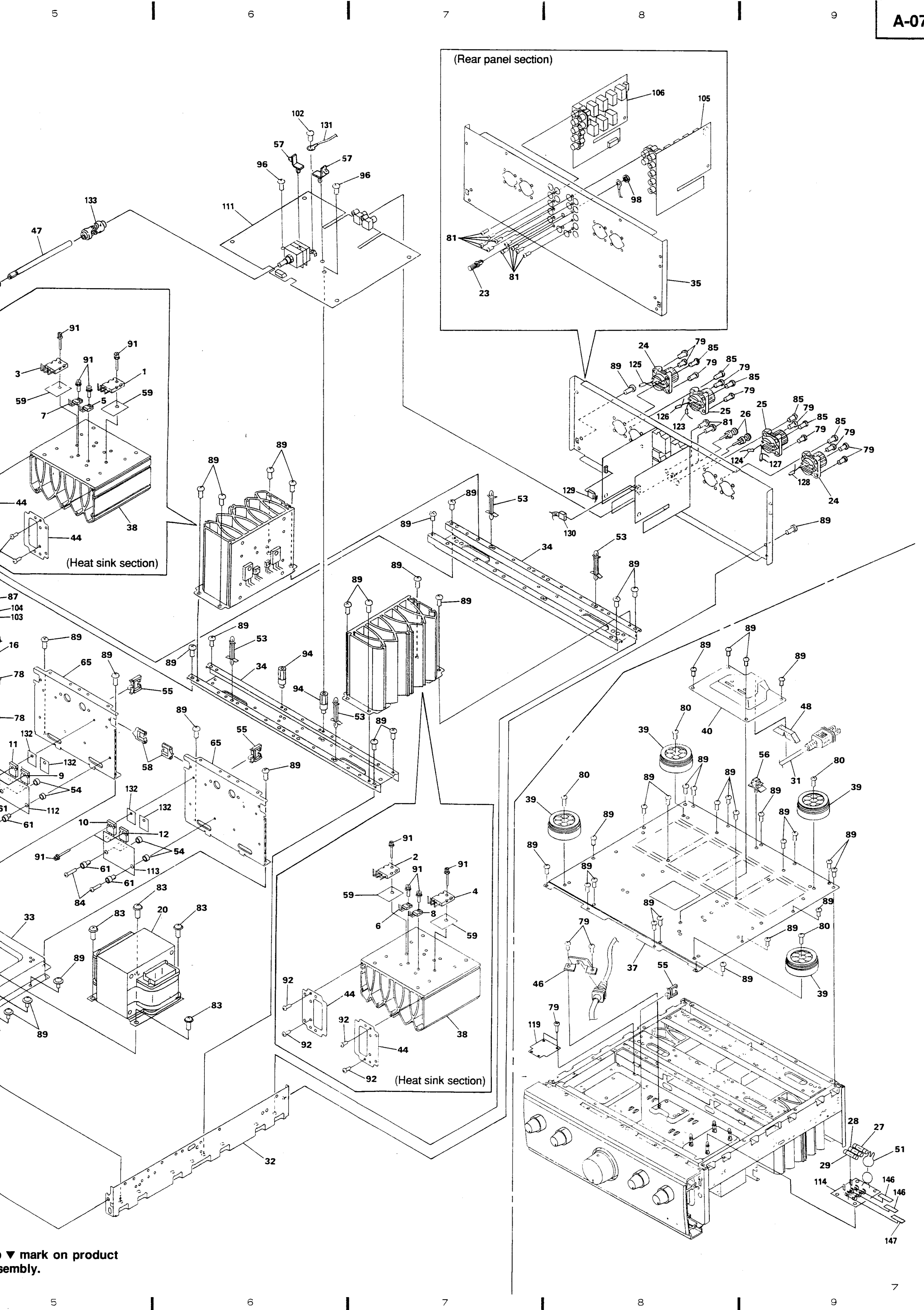

(Rear panel section)

(Heat sink section)

(Heat sink section)

▼ mark on product assembly.

2. SCHEMATIC AND PCB CONNECTION DIAGRAMS

2.1 OVERALL WIRING DIAGRAM, MOTHER, DIODE L, DIODE R, AC, SUB TRANS 1, SUB TRANS 2, EYE, INPUT L, INPUT R, GAIN SEL, LED, POWER SW, MO

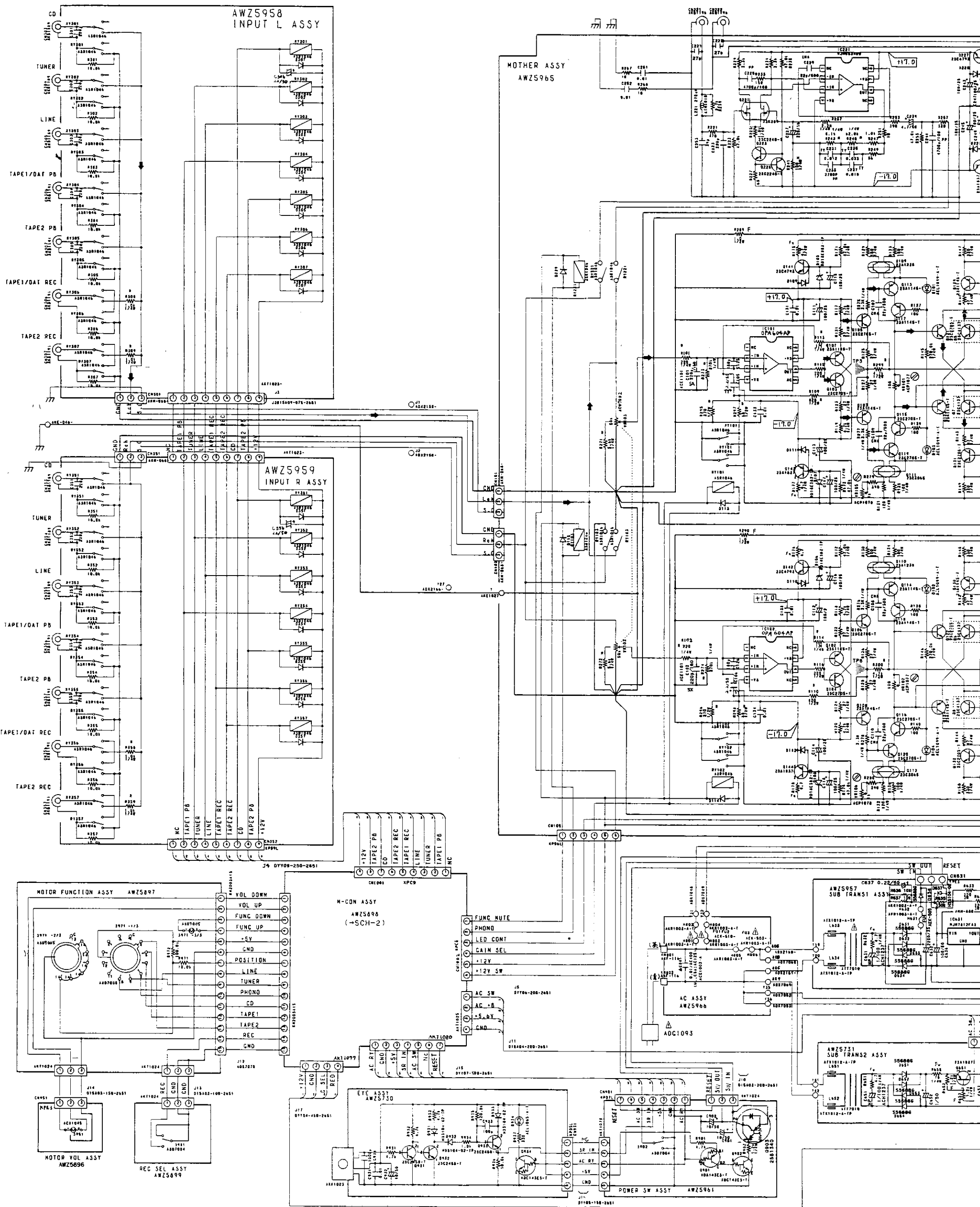

SCH-1

OVERALL, MOTHER ASSY, DIODE L ASSY, DIODE R ASSY, AC ASSY, SUB TRANS 1 ASSY, SUB TRANS 2 ASSY, EYE ASSY, INPUT L ASSY, INPUT R ASSY, GAIN SEL ASSY, LED ASSY, POWER SW ASSY, MOTOR VOL ASSY, MOTOR FUNCTION ASSY, REC SEL ASSY

POWER SW, MOTOR VOL, MOTOR FUCTION AND REC SEL ASSEMBLIES

→ SIGNAL ROUTE

SCH-1

NOTE FOR SCHEMATIC DIAGRAMS (Type 1A)

- When ordering service parts, be sure to refer to "PARTS LIST of EXPLODED VIEWS" or "PCB PARTS LIST".
- Since these are basic circuits, some parts of them or the values of some components may be changed for improvement.
- RESISTORS:**
Unit: k: kΩ, M: MΩ, or Ω unless otherwise noted.
Rated power: 1/4W, 1/8W, 1/10W unless otherwise noted.
Tolerance: (F): ±1%, (G): ±2%, (K): ±10%, (M): ±20% or ±5% unless otherwise noted.
- CAPACITORS:**
Unit: p: pF or μF unless otherwise noted.
Ratings: capacitor (μF) voltage (V) unless otherwise noted.
Rated voltage: 50V except for electrolytic capacitors.
- COILS:**
Unit: m: mH or μH unless otherwise noted.
- VOLTAGE AND CURRENT:**
V: Signal voltage at rated output.
or - V: DC voltage (V) at no input signal unless otherwise noted.
Value in () is DC voltage at rated power.
mA: mA
or - mA: DC current at no input signal unless otherwise noted.

7. OTHERS:
• ⊕ or ⊙: Adjusting point.
• ⊙: Measurement point.
• The Δ mark found on some component parts indicates the importance of the safety factor of the parts. Therefore, when replacing, be sure to use parts of identical designation.
8. **SCH-□ ON THE SCHEMATIC DIAGRAM:**
• SCH-□ indicates the drawing number of the schematic diagram. (SCH stands for schematic diagram.)
9. **SWITCHES** (Underline indicates switch position):
GAIN SEL ASSY
S601: GAIN SELECTOR
- POWER SW ASSY
S902: POWER STANDBY/ON OFF
- MOTOR FUNCTION ASSY
S971: INPUT SELECTOR
- REC SEL ASSY
S981: REC OUT

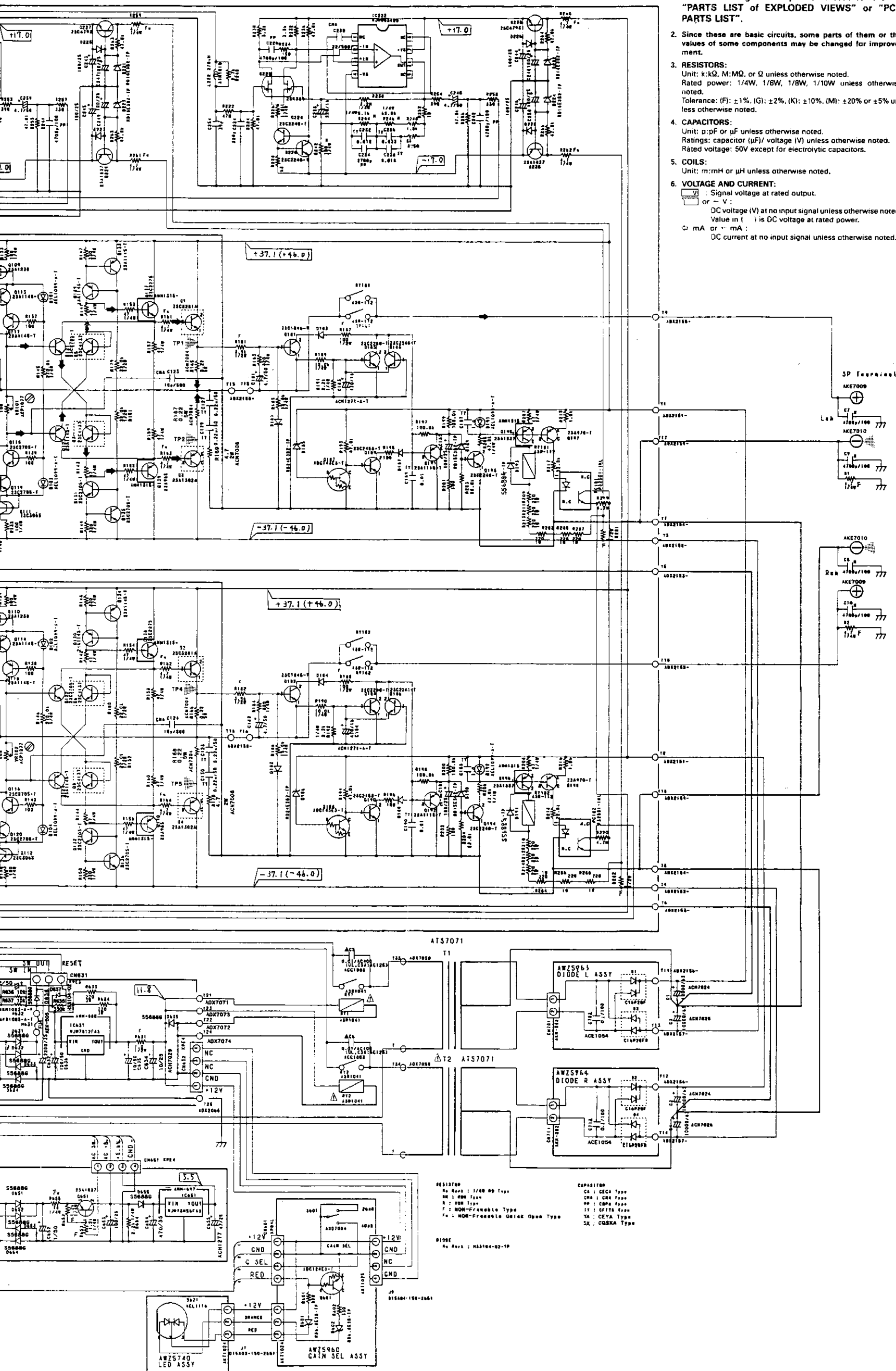

RESISTOR
R: Resistor Type
M: 0.1W Type
F: Non-Frangible Type
F: Non-Frangible Geiger Open Type

CAPACITOR
C: CECA Type
CA: CAA Type
CB: CBB Type
CF: CFF Type
YA: CEVA Type
SX: COSMA Type

DIODE
R: Resistor Type

OVERALL, MOTHER ASSY, DIODE L ASSY, DIODE R ASSY, AC ASSY, SUB TRANS 1 ASSY, SUB TRANS 2 ASSY, EYE ASSY, INPUT L ASSY, INPUT R ASSY, GAIN SEL ASSY, LED ASSY, POWER SW ASSY, MOTOR VOL ASSY, MOTOR FUCTION ASSY, REC SEL ASSY

SCH-1

A

B

C

D

INPUT L ASSY

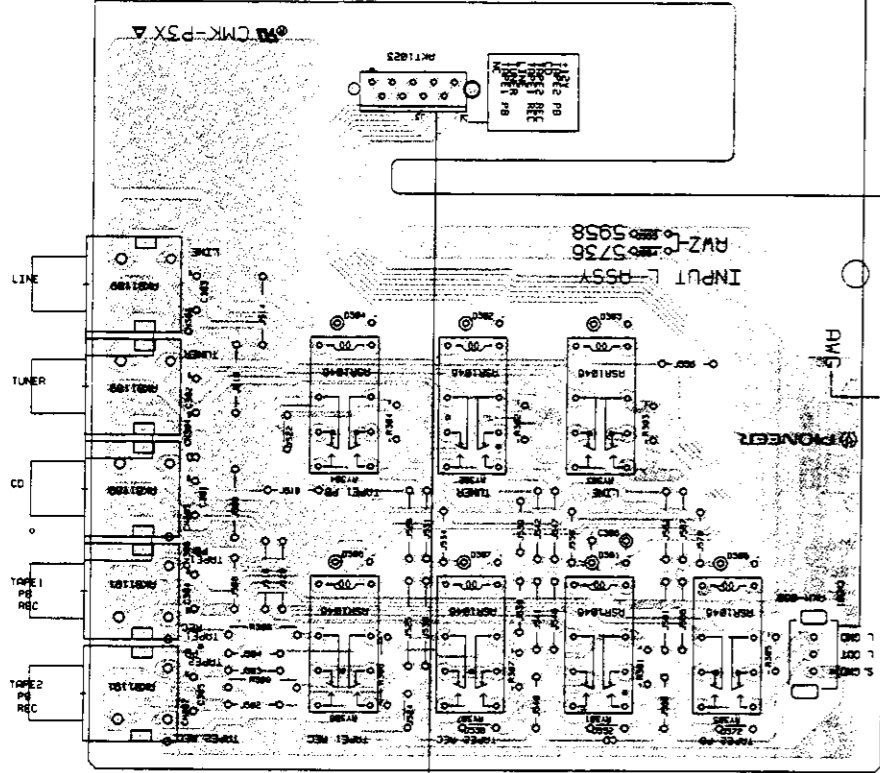

INPUT R ASSY

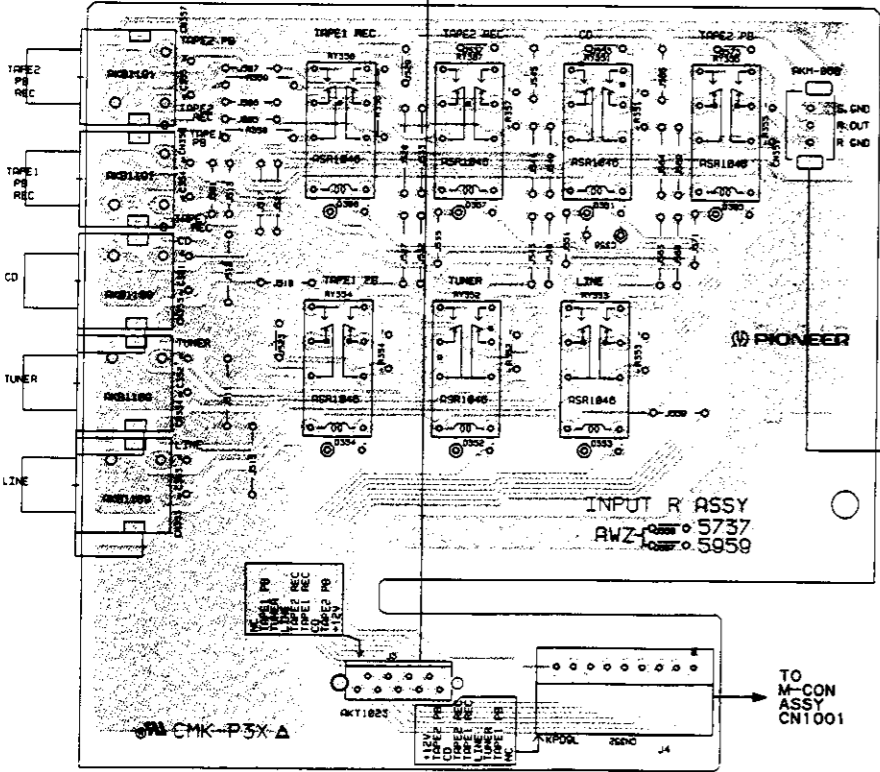

MOTHER ASSY

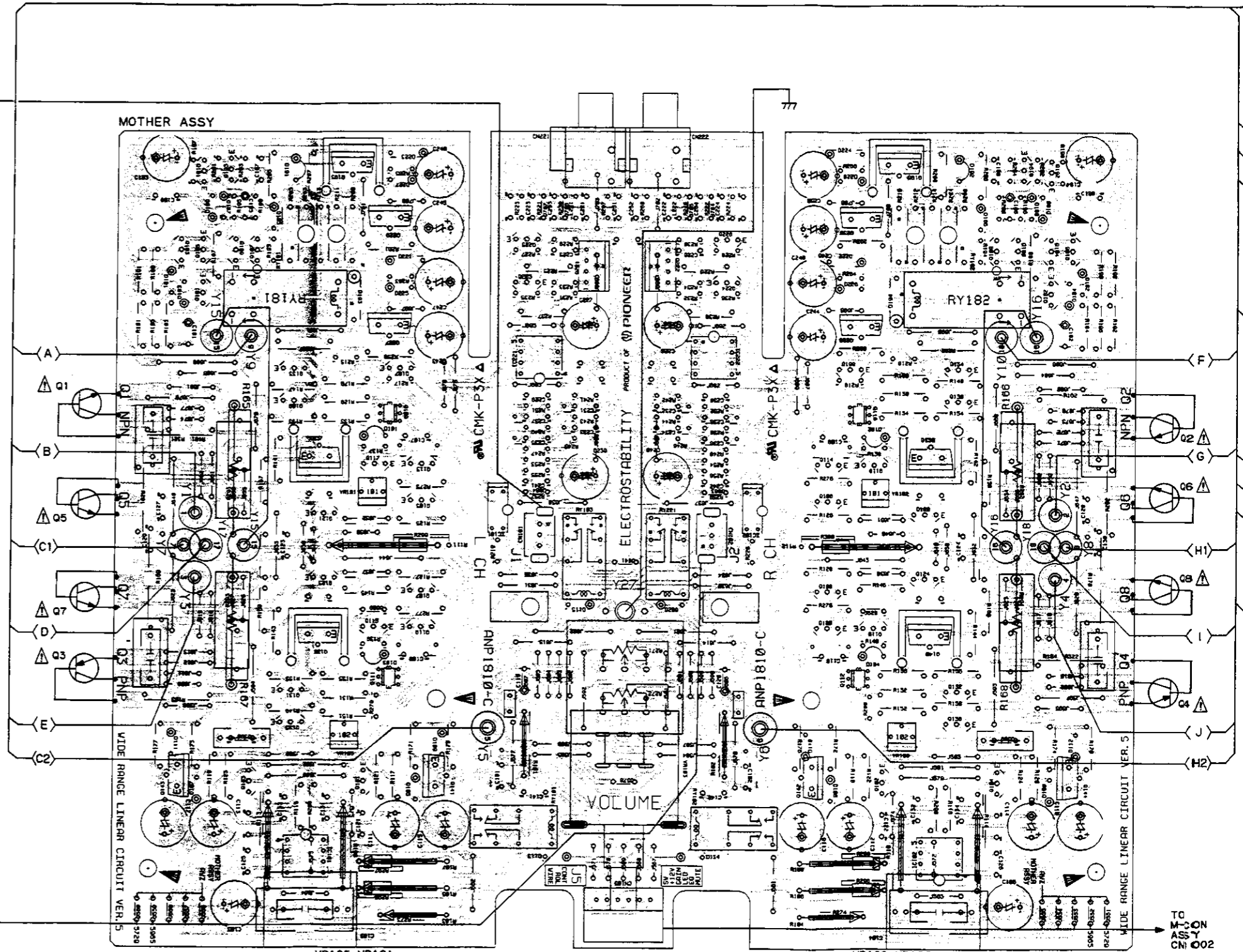

Q1	Q191	Q193	Q133	Q195	Q229	Q197	IC181	Q225	Q221	Q222	Q226	IC182	Q114	Q230	Q196	Q134	Q194	Q192	Q2
Q5	Q183	Q189	Q129	Q137	Q227	Q113		Q223			Q224		Q106	Q228	Q138	Q130	Q188	Q184	Q6
Q7	Q185	Q187	Q131	Q121	Q109	Q105		IC221			IC222		Q108	Q198	Q122	Q132	Q190	Q186	Q8
Q3	Q181	Q103	Q135	Q123	Q117	Q107							Q120	Q110	Q124	Q136	Q104	Q182	Q4
	Q143			Q139	Q115	Q119							Q112	Q118	Q140			Q144	
				IC101	Q111	Q141							Q142	Q116	IC102				
					Q101								Q102						

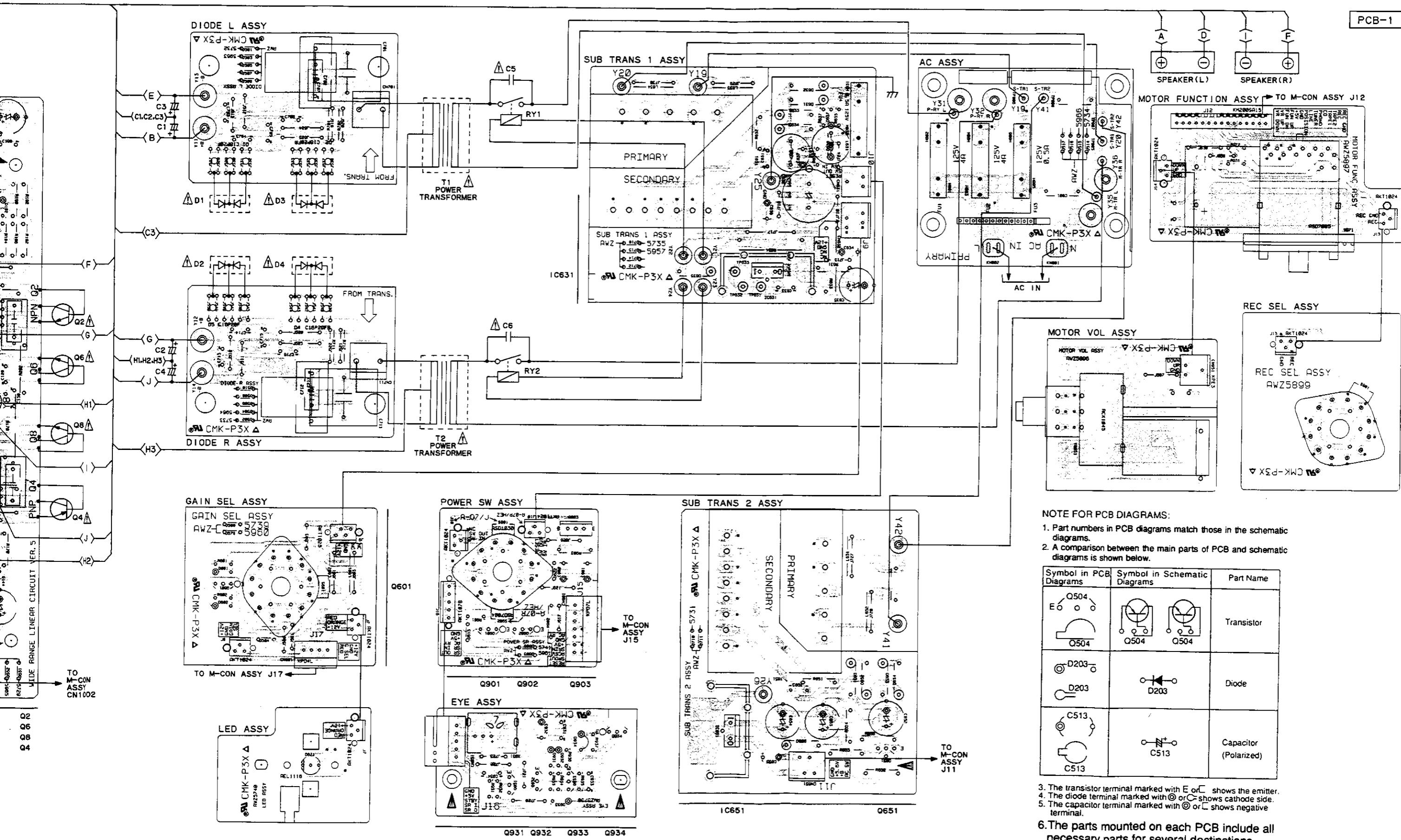

NOTE FOR PCB DIAGRAMS:

1. Part numbers in PCB diagrams match those in the schematic diagrams.
2. A comparison between the main parts of PCB and schematic diagrams is shown below.

Symbol in PCB Diagrams	Symbol in Schematic Diagrams	Part Name
 Q504	 Q504	Transistor
 D203	 D203	Diode
 C513	 C513	Capacitor (Polarized)

3. The transistor terminal marked with E or \perp shows the emitter.
4. The diode terminal marked with \ominus or \perp shows cathode side.
5. The capacitor terminal marked with \ominus or \perp shows negative terminal.
6. The parts mounted on each PCB include all necessary parts for several destinations. For further information for respective destinations, be sure to check with the schematic diagram.

● This diagram is viewed from the mounted parts side.

2.2 M-CON ASSEMBLY

M-CON ASSY AWZ5898

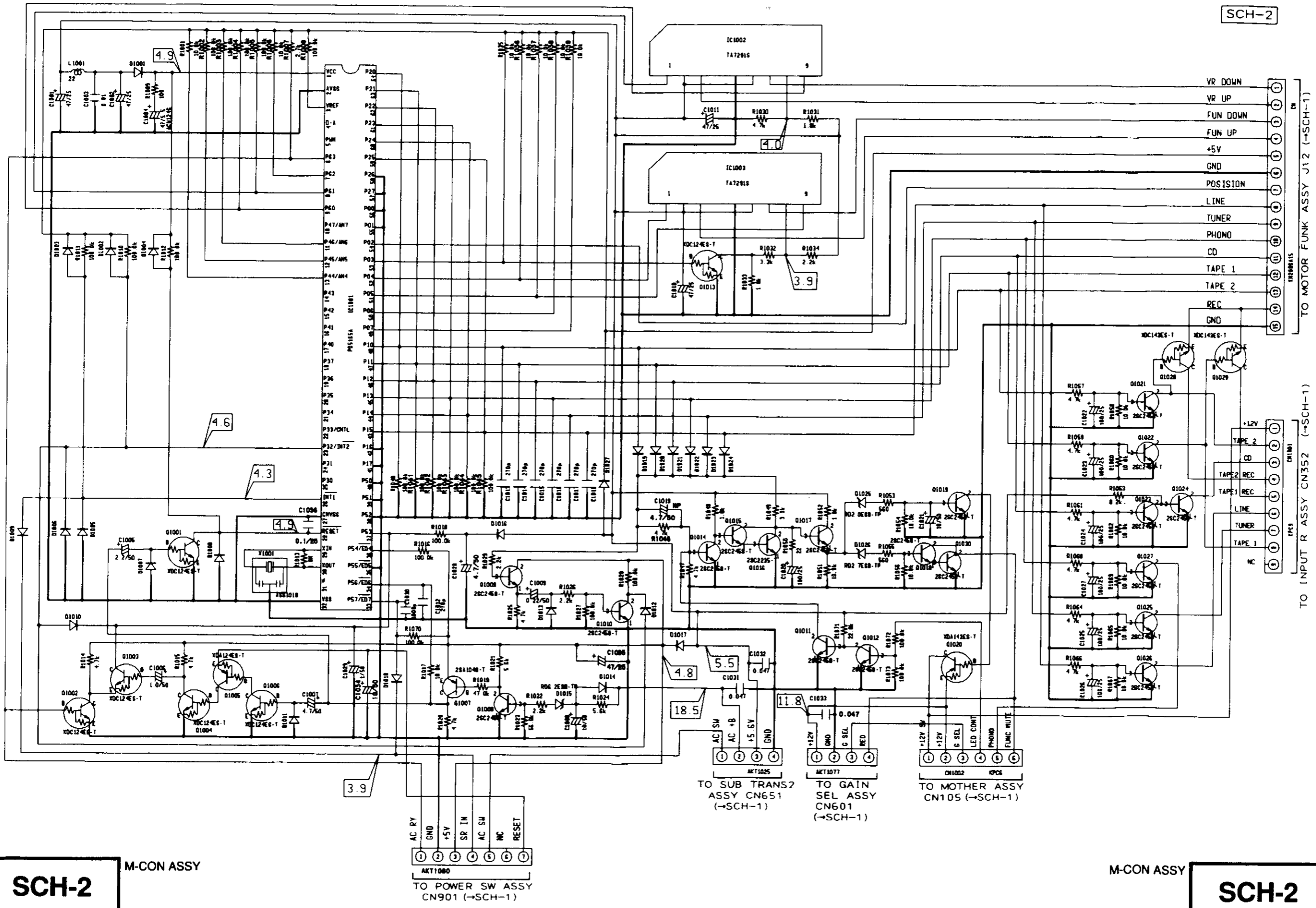

SCH-2

M-CON ASSY

M-CON ASSY

SCH-2

• This diagram is viewed from the mounted parts side.

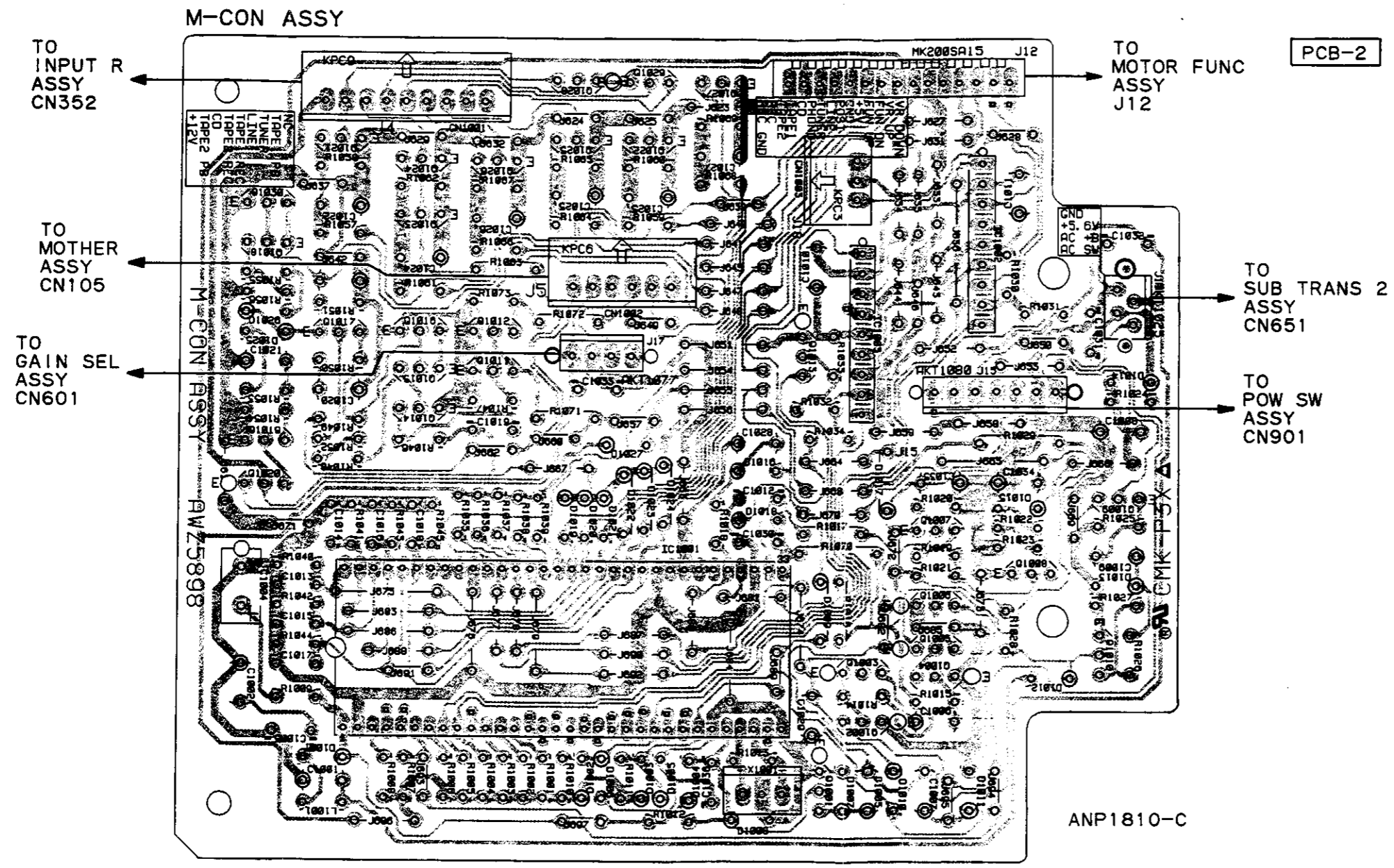

Q1030	Q1021	Q1024	Q1026	Q1028	Q1029	Q1027	Q1013	Q1003	Q1007	Q1008	Q1009
Q1018	Q1017	Q1023	Q1012	Q1025	Q1022			Q1002	Q1006	IC1002	Q1010
Q1019		Q1016	Q1011		IC1001			Q1001	Q1005		
Q1020		Q1015						IC1003	Q1004		
		Q1014									

A

B

C

D

Mark No.	Description	Parts No.	Mark	Mark No.	Description	Parts No.	Mark
REC SEL ASSY				CAPACITORS			
SWITCHES AND RELAYS				C901,C902			
S981				CEAS100M50			
ASD7004				RESISTORS			
INPUT L ASSY				R902			
SEMICONDUCTORS				Other Resistors			
D301-D307				RD1/4PM122J			
HSS104-02				RD1/8PM□□□J			
SWITCHES AND RELAYS				EYE ASSY			
RY301-RY307				SEMICONDUCTORS			
ASR1046				Q931-Q933			
CAPACITORS				Q934			
C301-C305				D934			
C306				D931-D933			
CCCCL221J50				CAPACITORS			
CEAS220M50				C932			
RESISTORS				C934			
R308,R309				C931			
Other Resistors				C933			
RD1/8PM□□□J				RESISTORS			
OTHERS				All Resistors			
CN303-CN305 1P PINJACK				RD1/8PM□□□J			
CN306,CN307 2P PINJACK				OTHERS			
CABLE HOLDER				REMOTE RECEIVER UNIT			
AKB1189				AXX1023			
AKB1191				SUB TRANS 2 ASSY			
AKT1023				SEMICONDUCTORS			
INPUT R ASSY				IC651			
SEMICONDUCTORS				Q651			
D351-D357				D651-D655			
HSS104-02				COILS AND FILTERS			
SWITCHES AND RELAYS				△ L651,L652			
RY351-RY357				ATX1012			
ASR1046				TRANSFORMERS			
CAPACITORS				△ T651			
C351-C355				CAPACITORS			
C356				C651			
CCCCL221J50				C655 (47/25V)			
CEAS220M50				C652			
RESISTORS				C653			
R358,R359				C654			
Other Resistors				RESISTORS			
RD1/8PM□□□J				△ R655			
OTHERS				△ R651			
CN353-CN355 1P PINJACK				Other Resistors			
CN356,CN357 2P PINJACK				RD1/4PM□□□J			
CABLE HOLDER				OTHERS			
AKB1189				SCREW			
AKB1191				HEAT SINK M			
AKT1023				CN651 CONNECTOR (4P)			
GAIN SEL ASSY				ABA-298			
SEMICONDUCTORS				ANH-697			
Q601				KPE4			
D601,D602				RD1/4PM□□□J			
XDC124ES				SUB TRANS 1 ASSY			
RD6.8ESB				SEMICONDUCTORS			
SWITCHES AND RELAYS				IC631			
S601				D637			
ASD7004				D631-D636			
RESISTORS				COILS AND FILTERS			
All Resistors				△ L633,L634			
RD1/8PM□□□J				ATX1012			
POWER SW ASSY				TRANSFORMERS			
SEMICONDUCTORS				△ T631			
Q903				ATT7010			
Q901				SUB TRANS 2 ASSY			
Q902				SEMICONDUCTORS			
XDA143ES				IC631			
XDC143ES				D637			
SWITCHES AND RELAYS				D631-D636			
S902				S5688G			
ASD7004				COILS AND FILTERS			
POWER SW ASSY				△ L633,L634			
SEMICONDUCTORS				ATX1012			
Q903				TRANSFORMERS			
Q901				△ T631			
Q902				ATT7010			
XDA143ES				SUB TRANS 1 ASSY			
XDC143ES				SEMICONDUCTORS			
SWITCHES AND RELAYS				IC631			
S902				D637			
ASD7004				D631-D636			
POWER SW ASSY				COILS AND FILTERS			
SEMICONDUCTORS				△ L633,L634			
Q903				ATX1012			
Q901				TRANSFORMERS			
Q902				△ T631			
XDA143ES				ATT7010			
XDC143ES				SUB TRANS 2 ASSY			
SWITCHES AND RELAYS				SEMICONDUCTORS			
S902				IC631			
ASD7004				D637			
POWER SW ASSY				D631-D636			
SEMICONDUCTORS				S5688G			
Q903				COILS AND FILTERS			
Q901				△ L633,L634			
Q902				ATX1012			
XDA143ES				TRANSFORMERS			
XDC143ES				△ T631			
SWITCHES AND RELAYS				ATT7010			
S902				SUB TRANS 1 ASSY			
ASD7004				SEMICONDUCTORS			
POWER SW ASSY				IC631			
SEMICONDUCTORS				D637			
Q903				D631-D636			
Q901				S5688G			
Q902				COILS AND FILTERS			
XDA143ES				△ L633,L634			
XDC143ES				ATX1012			
SWITCHES AND RELAYS				TRANSFORMERS			
S902				△ T631			
ASD7004				ATT7010			

3. PCB PARTS LIST

NOTES:

- Parts marked by "NSP" are generally unavailable because they are not in our Master Spare Parts List.
- The Δ mark found on some component parts indicates the importance of the safety factor of the part. Therefore, when replacing, be sure to use parts of identical designation.
- Parts marked by "⊙" are not always kept in stock. Their delivery time may be longer than usual or they may be unavailable.
- When ordering resistors, first convert resistance values into code form as shown in the following examples.

Ex.1 When there are 2 effective digits (any digit apart from 0), such as 560 ohm and 47k ohm (tolerance is shown by J = 5%, and K = 10%).

560Ω	→	56 × 10 ¹	→	561	RD1/8PM	<u>5</u> <u>6</u> <u>1</u> J
47kΩ	→	47 × 10 ³	→	473	RD1/4PS	<u>4</u> <u>7</u> <u>3</u> J
0.5Ω	→	0R5			RN2H	<u>0</u> <u>R</u> <u>5</u> K
1Ω	→	010			RS1P	<u>0</u> <u>1</u> <u>0</u> K

Ex.2 When there are 3 effective digits (such as in high precision metal film resistors).

5.62kΩ	→	562 × 10 ¹	→	5621	RN1/4PC	<u>5</u> <u>6</u> <u>2</u> <u>1</u> F
--------	---	-----------------------	---	------	-------	---------	---------------------------------------

Mark No.	Description	Parts No.	Mark	Mark No.	Description	Parts No.	Mark
----------	-------------	-----------	------	----------	-------------	-----------	------

LIST OF ASSEMBLIES

NSP	CONTROL ASSY		
—	LED ASSY	AWZ5740	
—	MOTOR VOL ASSY	AWZ5896	
—	MOTOR FUNCTION ASSY	AWZ5897	
—	M-CON ASSY	AWZ5898	
—	REC SEL ASSY	AWZ5899	
—	INPUT L ASSY	AWZ5958	
—	INPUT R ASSY	AWZ5959	
—	GAIN SEL ASSY	AWZ5960	
—	POWER SW ASSY	AWZ5961	
NSP	AF ASSY		
—	EYE ASSY	AWZ5730	
—	SUB TRANS 2 ASSY	AWZ5731	
—	SUB TRANS 1 ASSY	AWZ5957	
—	DIODE L ASSY	AWZ5963	
—	DIODE R ASSY	AWZ5964	
—	MOTHER ASSY	AWZ5965	
—	AC ASSY	AWZ5966	

LED ASSY

SEMICONDUCTORS
D621

MOTOR VOL ASSY

RESISTORS
VR951

OTHERS

CN951 CONNECTOR (3P)

MOTOR FUNCTION ASSY

SWITCHES AND RELAYS
S971

RESISTORS

All Resistors

OTHERS

J13 JUMPER WIRE

M-CON ASSY

SEMICONDUCTORS

IC1001	PD5165A
IC1002,IC1003	TA7291S
Q1007	2SA1048
Q1016	2SC2235
Q1008-Q1012,Q1014,Q1015	2SC2458
Q1017-Q1019,Q1021-Q1027,Q1030	2SC2458
Q1005	XDA124ES
Q1020	XDA143ES
Q1001-Q1004,Q1006,Q1013	XDC124ES
Q1028,Q1029	XDC143ES
D1001-D1014,D1016-D1024,D1027	HSS104-02
D1025	RD2.0ESB
D1026	RD2.7ESB
D1015	RD6.2ESB

COILS AND FILTERS

L1001	LAU220J
-------	---------

CAPACITORS

C1004	ACH1246
C1012	CCCSL271J50
C1019	CEANP4R7M50
C1006,C1029	CEAS010M50
C1008,C1021,C1034	CEAS100M50
C1020,C1022-C1027	CEAS101M25
C1005	CEAS2R2M50
C1001,C1002,C1010,C1011,C1035	CEAS470M25
C1007,C1028	CEAS4R7M50
C1009	CEASR22M50
C1030	CKCYB102K50
C1003	CKCYF103Z50
C1031-C1033	CKCYF473Z50
C1036	CKCYX104M25
C1013-C1018	CKPUYB271K50

RESISTORS

All Resistors

RD1/8PM□□□J

OTHERS

X1001	CABLE HOLDER (4P)	AKT1077
CN1002	CABLE HOLDER (7P)	AKT1080
CN1001	CERAMIC RESONATOR	ASS1018
	JUMPER CONNECTOR	KPC6
	CONNECTOR (9P)	KPC9

Mark No.	Description	Parts No.	Mark	Mark No.	Description	Parts No.	Mark
CAPACITORS				D193,D194		S5688G	
C631		ACH1237		COILS AND FILTERS			
C634 (10/25V)		ACH7029		L221,L222 (270)		ATH1010	
C635		CEAS100M50		SWITCHES AND RELAYS			
C636		CEAS101M50		RY181,RY182		ASR-112	
C632		CEAS222M35		RY101-RY103,RY221		ASR1046	
C637		CEASR22M50		CAPACITORS			
RESISTORS				C125,C126		CCCSL181J50	
R631		RD1/2PMF010J		C223,C224		CCCSL221J50	
△ R632		RFA1/4PS4R7J		C221,C222		CCCSL270J50	
△ R633,R634		RS3LMF221J		C253,C254		CCCSL390J50	
Other Resistors		RD1/8PM□□□J		C111-C118,C185,C186		CEAS101M25	
OTHERS				C243-C250		CEAS101M25	
SCREW		ABA-298		C227,C228		CEAS221M16	
H631,H632 FUSE CLIP		AKR1003		C183,C184		CEAS471M16	
HEAT SINK		ANH-880		C181,C182,C239,C240		CEAS4R7M50	
CN631 CONNECTOR (3P)		KPE3		C189,C190		CFTYA103J50	
CN632 CONNECTOR (4P)		KPE4		C187,C188		CFTYA105J50	
DIODE L ASSY				C231,C232		CFTYA123J50	
CAPACITORS				C237,C238		CFTYA183J50	
C702 (0.1)		ACE1054		C127-C130		CFTYA224J50	
DIODE R ASSY				C105,C106		CFTYA225J50	
CAPACITORS				C235,C236		CFTYA333J50	
C712 (0.1)		ACE1054		C131-C134,C251,C252		CKCYF103Z50	
MOTHER ASSY				C123,C124		CMA100D500	
SEMICONDUCTORS				C107-C110,C229,C230		CMA220J500	
IC221,IC222		NJM5534DD		C233,C234		CQPA272J100	
IC101,IC102		OPA604AP-A		C225,C226,C241,C242		CQPA472J100	
IC181,IC182		PS2501-1KL		C101,C102		CQSA221J160	
Q191,Q192		2SA1115		RESISTORS			
Q101,Q102,Q107,Q108		2SA1145		R165-R168 (0.22/5W)		ACN7004	
Q113,Q114,Q117,Q118		2SA1145		R169,R170 (4.7/2W)		ACN7006	
Q123,Q124,Q129,Q130		2SA1145		R151,R152,R179,R180		RD1/2PMF223J	
Q133,Q134		2SA1145		△ R281,R282,R289,R290		RD1/2PMF010J	
Q109,Q110		2SA1238		△ R187,R188		RD1/2PMF101J	
Q143,Q144,Q195,Q196		2SA1837		△ R181,R182		RD1/2PMF392J	
Q229,Q230		2SA1837		R129,R130,R133-R136		RD1/4PM101J	
Q197,Q198		2SA970		R189,R190		RD1/4PM103J	
Q139,Q140		2SA985		R131,R132		RD1/4PM121J	
Q181-Q186,Q193,Q194		2SC2240		R185,R186		RD1/4PM153J	
Q223-Q226		2SC2240		R225,R226		RD1/4PM182J	
Q137,Q138		2SC2275		R115,R116		RD1/4PM221J	
Q189,Q190		2SC2458		R191,R192		RD1/4PM222J	
Q103-Q106,Q115,Q116		2SC2705		R237,R238		RD1/4PM225J	
Q119-Q122,Q131,Q132		2SC2705		R121-R128		RD1/4PM270J	
Q135,Q136		2SC2705		R145,R146		RD1/4PM274J	
Q111,Q112		2SC3065		R147-R150		RD1/4PM331J	
Q141,Q142,Q227,Q228		2SC4793		R275-R278		RD1/4PM332J	
Q221,Q222		2SK389		R141-R144,R153-R160		RD1/4PM470J	
Q187,Q188		XDC143ES		R207,R208		RD1/4PM470J	
D101-D104,D191,D192		AEL1099		R117-R120		RD1/4PM472J	
D109-D115,D181-D184		HSS104-02		R171-R174,R205,R206		RD1/4PM473J	
D187,D188,D225-D229		HSS104-02		R183,R184		RD1/4PM821J	
D189,D190		RD15ESB2		R295,R296		RDR1/2PM271J	
D105-D108,D221-D224		RD18ESB2		R299,R300		RDR1/2PM472J	
D185,D186		RD24ESB2					

Mark	No.	Description	Parts No.	Mark
	R297,R298		RDR1/2PM680J	
	R109,R110		RDR1/2PM821J	
	R113,R114		RDR1/4PM105J	
	R101,R102		RDR1/4PM221J	
	R273,R274		RDR1/4PM274J	
	R271,R272		RDR1/4PM562J	
△	R161-R164,R175-R178		RFA1/4PS4R7J	
△	R259-R262		RFA1/4PS4R7J	
	R241,R242		RN1/4PC1000F	
	R243,R244		RN1/4PC5101F	
	R245,R246		RN1/4PC6202F	
△	R209-R214,R283-R286		RS1LMF271J	
△	R287,R288		RS1PMF221J	
	VR101,VR102 (100/0.5W)		ACP1077	
	VR105,VR106 (1/0.5W)		ACP1078	
	VR103 (50×2)		ACW7002	
	Other Resistors		RD1/8PM□□□J	
OTHERS				
	SCREW (STEEL)		ABA1009	
	CN221,CN222 PIN JACK (1P)		AKB1196	
	STAR TERMINAL A		AKE1028	
AC ASSY				
CAPACITORS				
△	C801 (0.01/400V)		ACG1003	
OTHERS				
	H801-H806 FUSE CLIP		AKR1003	

4. BLOCK DIAGRAM

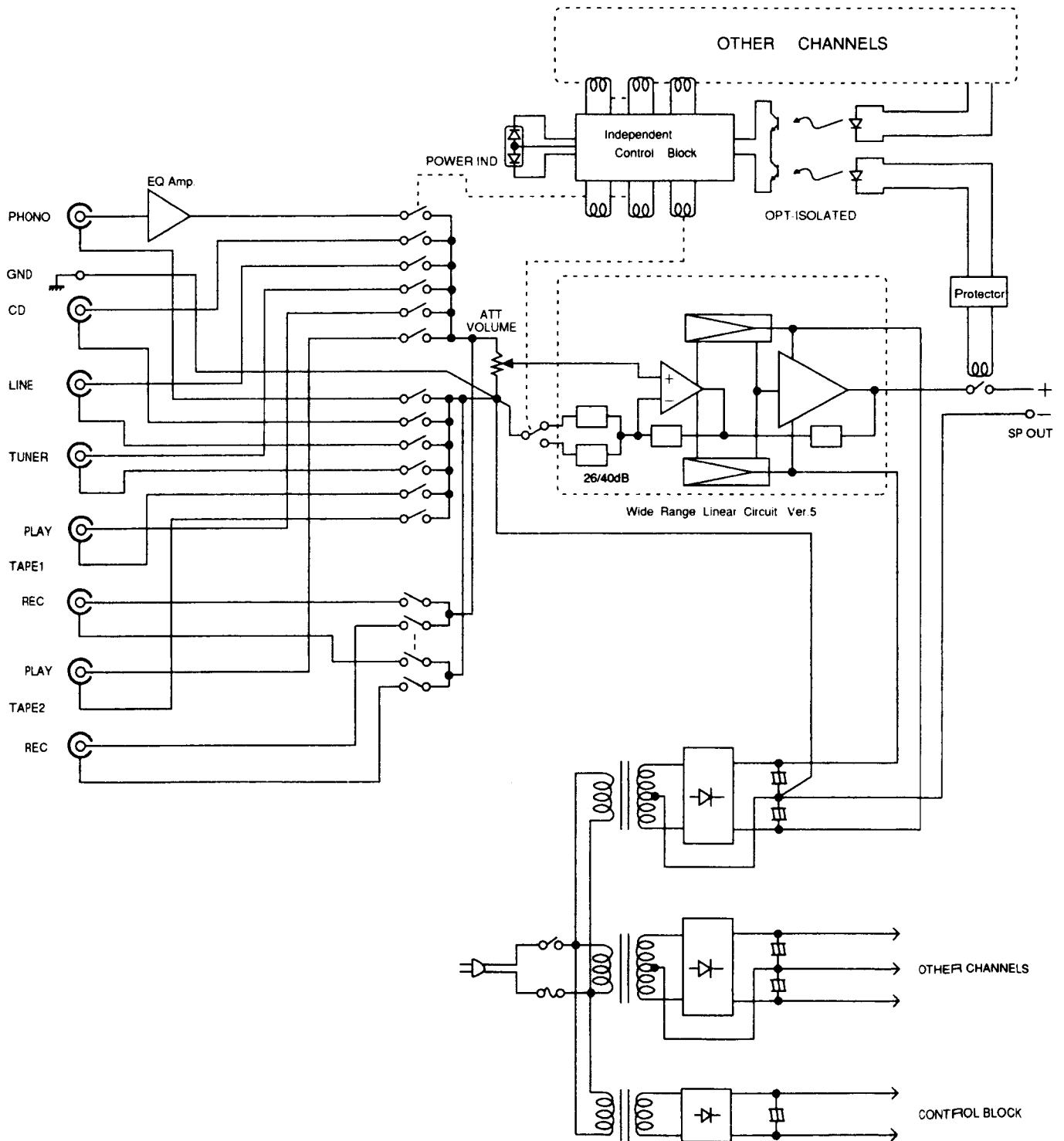

5. ADJUSTMENTS

1. Connect the measurement equipment.
2. Set VR105 (VR106) for DC balance adjustment to the center position.
3. Turn VR101 (VR102) for idle current adjustment counterclockwise as far as it will go.
4. Turn the VOLUME control on the front panel counterclockwise as far as it will go.
5. Turn on the power.
6. Adjust VR101 (VR102) so that Ⓐ (Ⓓ) is $+22\text{ mV} \pm 5\text{ mV}$ with respect to Ⓑ (Ⓔ).
7. Adjust VR105 (VR106) so that Ⓒ (Ⓕ) is $0\text{ mV} \pm 3\text{ mV}$ with respect to the negative terminal of a Lch (Rch) speaker.

Note: Adjust five minutes or more after the power is turned on.

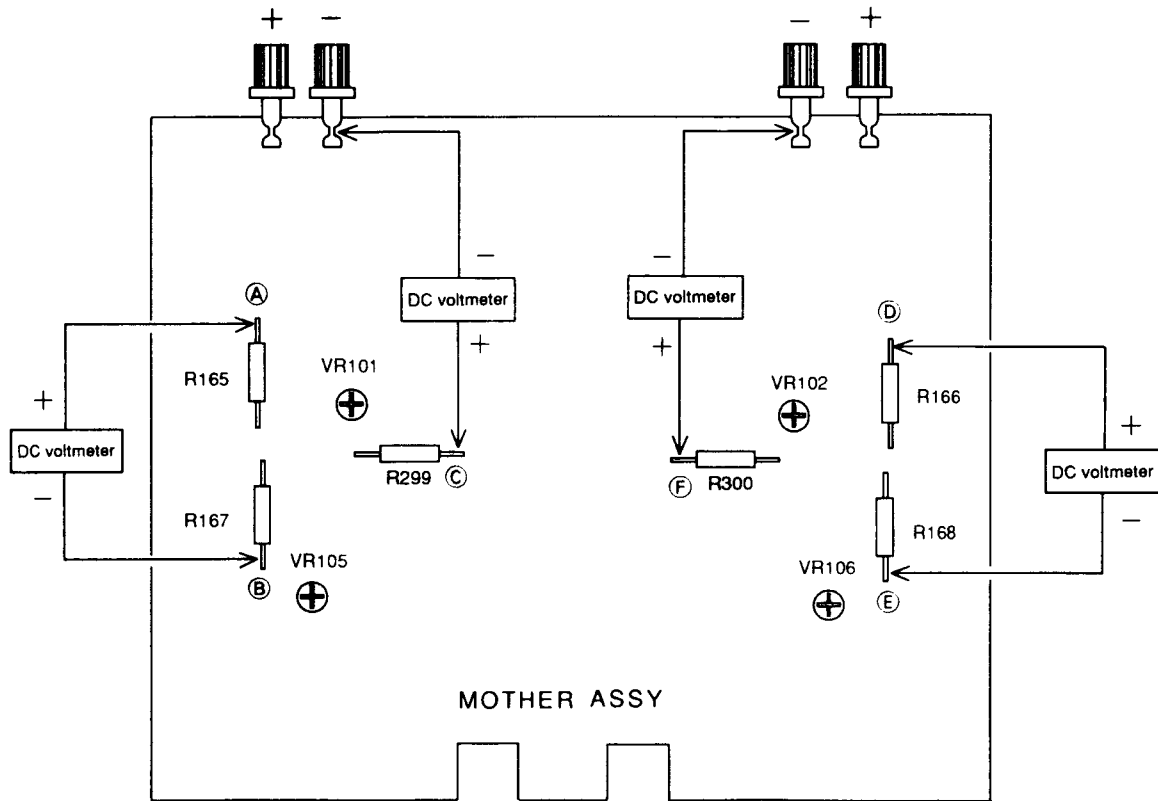

Connection and Adjustment Point

7. SPECIFICATIONS

Amplifier Section

DIN Continuous power output (both channels driven at 1 kHz)	
T.H.D. 1.0 %, 8 Ω	80 W + 80 W
T.H.D. 1.0 %, 4 Ω	120 W + 120 W
Signal-to-Noise ratio (DIN, continuous power/50 mW)	
PHONO (MM)	70 dB/65 dB*
CD, TUNER, TAPE 1, TAPE 2, LINE	95 dB/67 dB*
Total harmonic distortion*	
20 Hz to 20 kHz, 35 W, 8 Ω	0.01 %*
Input sensitivity/impedance	
PHONO (MM)	2.8 mV/50 k Ω
CD, TUNER, TAPE 1, TAPE 2, LINE	200 mV/50 k Ω
Damping factor	
(1 kHz/20 Hz to 20 kHz), 8 Ω	350/300
Frequency response	
PHONO (MM)	20 Hz to 20 kHz \pm 0.3 dB
AUX	5 Hz to 400 kHz \pm 0.3 dB
Output level/impedance	
TAPE REC	200 mV/1 k Ω

● Above specifications are for when power supply is 230 V.

Power Supply/Miscellaneous

Power Requirements	a.c. 220 — 230 Volts, 50/60 Hz
Power Consumption	600 W
Dimensions	440 (W) x 476 (D) x 163 (H) mm
Weight (without package)	18.4 kg

Accessories

Operating instructions	1
Remote control unit	1
Batteries (IEC AAA/R03)	2

NOTE:

Specifications and design are subject to possible modification without notice, due to improvements.

* Measured by Audio Spectrum Analyzer.

6. PANEL FACILITIES

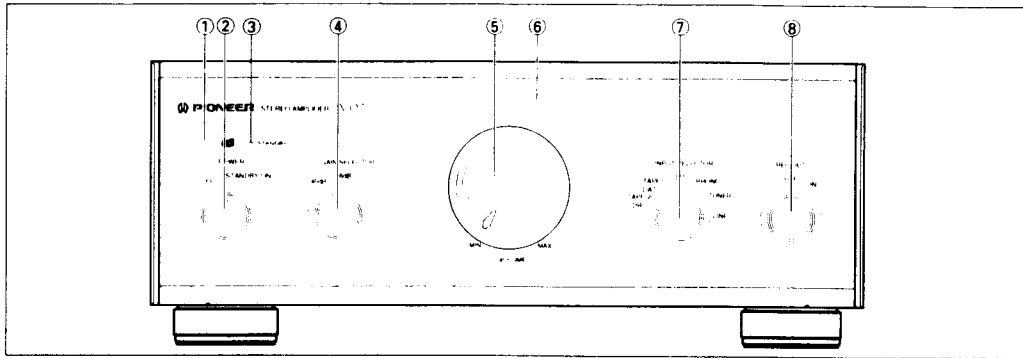

FRONT PANEL

1 Remote control sensor window

2 POWER STANDBY/ON OFF switch

OFF : When set to the OFF position, the main power flow is cut and the unit is no longer fully operational.

STANDBY/ON : When set to the STANDBY/ON position, power is supplied and the unit becomes operational. The unit can be switched between STANDBY and ON via remote control unit.

3 STANDBY indicator

Lights to indicate standby; goes out when POWER switch of the remote control unit is pushed.

When in STANDBY, power to the audio circuitry is cut. The control circuit however remains powered, so that the remote control operation is still possible.

4 GAIN SELECTOR

This enables 2-step power amp gain switching between 26 dB and 40 dB. 26 dB is the usual setting for audio reproduction with high S/N ratio. Switch to 40 dB if volume level is insufficient.

NOTE:

If you switch from 26 dB to 40 dB during operation, volume level suddenly becomes very high. When switching from 26 dB to 40 dB, be careful the volume level setting isn't too high.

5 VOLUME knob

Adjusts volume level.

6 Power indicator

This stays in orange for 6 seconds after switching ON and then turns red. The sound is muted while in orange.

7 INPUT SELECTOR

Use this to select between TAPE 2/CDR, TAPE 1/DAT, CD, PHONO, TUNER, and LINE, depending on which component you want to listen to. Because input switching is by relay, there's no sound for about 1 second after switching.

8 REC OUT switch

Switch this ON, and the source selected with the input selector is output through the REC OUT jacks. However, if you select TAPE 1/DAT there is no output from the TAPE 1/REC jacks, and if you select TAPE 2/CDR there is no output from the TAPE 2/REC jacks.

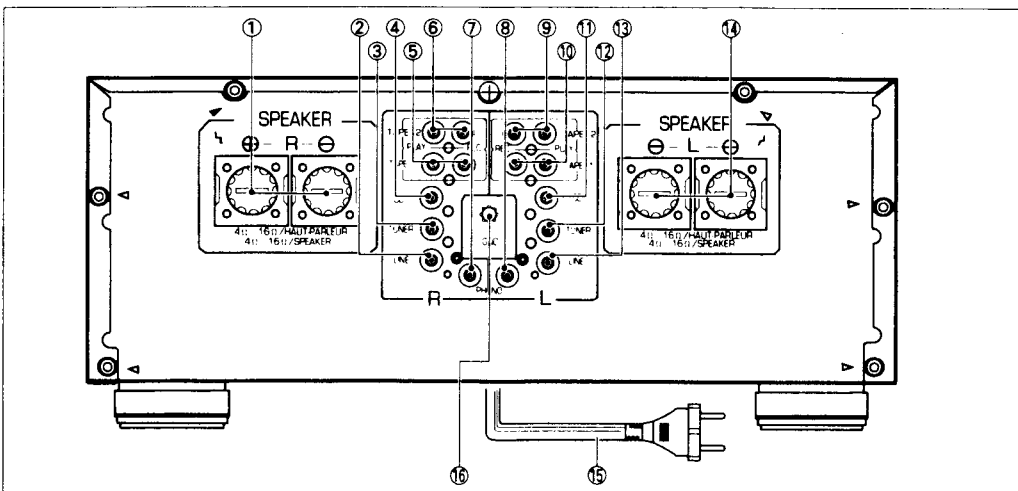

REAR PANEL

1 SPEAKERS terminals (right channel)

2 LINE jack (right)

3 TUNER jack (right)

4 CD jack (right)

5 TAPE 1 PLAY/REC jacks (right)

6 TAPE 2 PLAY/REC jacks (right)

7 PHONO jack (right)

8 PHONO jack (left)

9 TAPE 2 PLAY/REC jacks (left)

10 TAPE 1 PLAY/REC jacks (left)

11 CD jack (left)

12 TUNER jack (left)

13 LINE jack (left)

14 SPEAKERS terminals (left channel)

15 Power cord

Connect this cord to an AC wall socket.

16 GND (Turntable ground terminal)