

ADDITIONAL

 **PIONEER**

Service Manual

**ORDER NO.
ARP-052-0**

**NON SWITCHING AMP
STEREO AMPLIFIER**

A-8

- In the Model A-8 with the following serial numbers, the power amplifier and power transformer shall be changed as shown in the table below.

Type	Serial No.	Power amp. ass'y	Power transformer
KU	3600101 and thereafter	AWH-108	ATT-763-A
KC	3400801 and thereafter	AWH-110	ATT-764-A
HE	9404701 and thereafter	AWH-112	ATT-766-A
HB	9500901 and thereafter	AWH-112	ATT-766-A
S	2603301 and thereafter	AWH-108	ATT-765-A
S/G	2900301 and thereafter	AWH-108	ATT-765-A

- When servicing the model A-8, please refer to the serial number on the rear panel.
- This power amplifier employs Nested Feedback Loops (NFL). For the description of NFL, please refer to the circuit description (ART-762) of Model A-6 and A-5.

P.C. BOARD ASSEMBLIES

POWER AMPLIFIER ASSEMBLY (AWH-108, AWH-110)

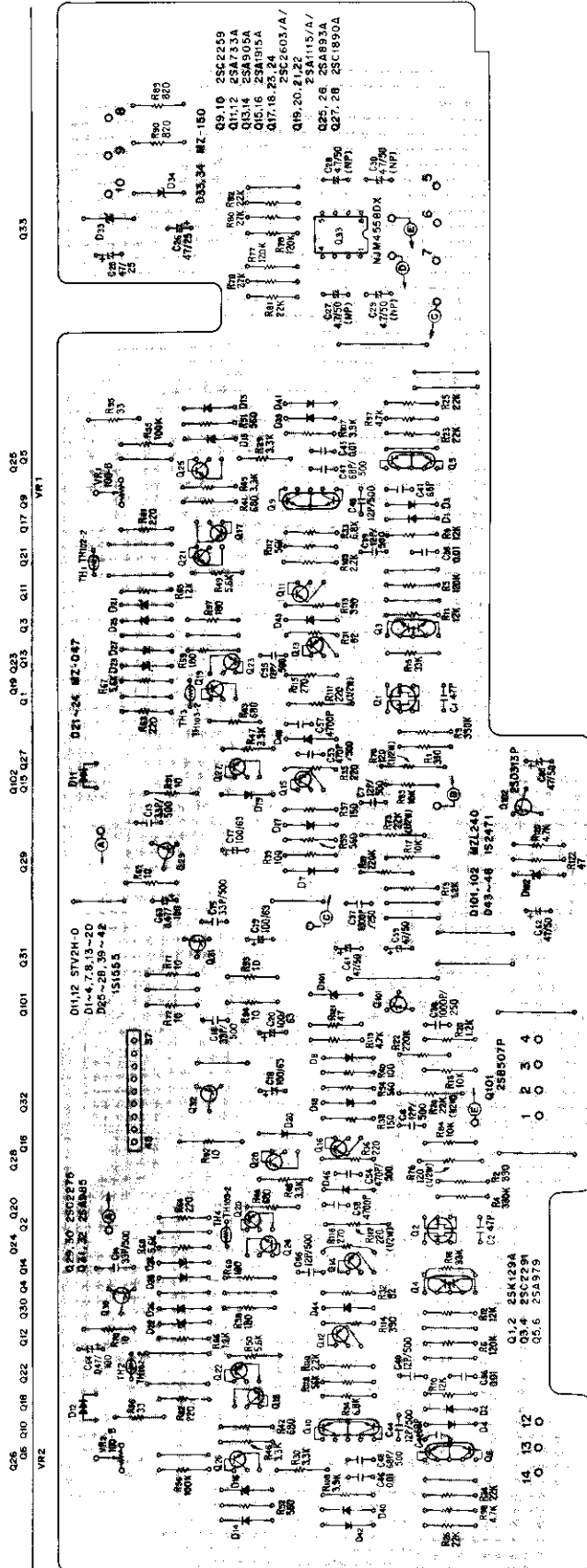

Parts List of AWH-108 (for KU, S and S/G types)

CAPACITORS

Mark	Part No.	Symbol & Description
	ACH-359 (CEXANP 4R7M 50)	C27-C30 Electrolytic (4,7/50V NP)
	CEA R47M 100L	C63, C64
	CEA 470M 25L	C25, C26
	CEA 470M 50L	C59-C62
	CEA 101M 63L	C17-C20
	CCDSL 120K 500	C7, C8, C39, C40, C43
	CCDSL 120K 500	C44, C55, C56
	CCDSL 330K 500	C13-C16
	CCDSL 680K 500	C47, C48
	CCDSL 470J 50	C1, C2
	CCDSL 680J 50	C41, C42
	CKDYB 472K 50	C57, C58
	CKDYB 471K 500	C53, C54
	CKDYF 103Z 50	C35, C36, C45, C46
	CQMA 102K 250	C37, C38

RESISTORS

Note: When ordering resistors, convert the resistance value into code form, and then rewrite the part no. as before.

Mark	Part No.	Symbol & Description
★	ACP-019 PD%PM □□□ J	VR1, VR2 Semifixed (100Ω) R1, R2, R5, R6, R15-R26, R29, R30 R33, R34, R45-R60, R65-R68, R77-R84, R89, R90, R95-R98, R107-R110, R115-R120, R121, R122
	RD%PM □□□ JNL	R3, R4, R9-R12
	RD%PMF □□□ J	R31, R32, R35-R44, R61-R64, R69-R72, R91-R94, R113, R114
	RD%PS □□□ J	R73-R76, R111, R112
★	TH102-2	TH1, TH2
★	TH103-2	TH3, TH4

SEMICONDUCTORS

Mark	Part No.	Symbol & Description
★★	2SK129A	Q1, Q2
★★	2SC2291	Q3, Q4
★★	2SA979	Q5, Q6
★★	2SC2259	Q9, Q10
★★	2SA733A (2SA1115/A/) (2SA992)	Q11, Q12
★★	2SA905A	Q13, Q14
★★	2SC1915A (2SC1915)	Q15, Q16
★★	2SC2603/A/ (2SC1400)	Q17, Q18, Q23, Q24
★★	2SA1115/A/ (2SA750)	Q19-Q22
★★	2SA893A	Q25, Q26
★★	2SC1890A	Q27, Q28
★★	2SC2275	Q29, Q30
★★	2SA985	Q31, Q32
★★	2SB507P (2SB834) (2SB682)	Q101
★★	2SD313P (2SD880) (2SD712)	Q102
★★	NJM4558DX (μPC4558C-P)	Q33
★	MZ-047	D21-D24
★	MZ-150 (WZ-150)	D33
★	MZL240	D101, D102
★	1S2471	D43-D46
★	1S1555 (1S2473) (1S2076) (US1035)	D1-D4, D7, D8, D13-D20, D25-D28, D39-D42
★	STV2H-0	D11, D12

Parts List of AWH-110 (for KC type)

CAPACITORS

Mark	Part No.	Symbol & Description
	ACH-359 (CEXANP 4R7M 50)	C27-C30 Electrolytic (4,7/50V NP)
	CEA R47M 100L	C63, C64
	CEA 470M 25L	C25, C26
	CEA 470M 50L	C59-C62
	CEA 101M 63L	C17-C20
	CCDSL 120K 500	C7, C8, C39, C40, C43
	CCDSL 120K 500	C44, C55, C56
	CCDSL 330K 500	C13-C16
	CCDSL 680K 500	C47, C48
	CCDSL 470J 50	C1, C2
	CCDSL 680J 50	C41, C42
	CKDYB 472K 50	C57, C58
	CKDYB 471K 500	C53, C54
	CKDYF 103Z 50	C35, C36, C45, C46
	CQMA 102K 250	C37, C38

RESISTORS

Note: When ordering resistors, convert the resistance value into code form, and then rewrite the part no. as before.

Mark	Part No.	Symbol & Description
★	ACP-019 RD%PM □□□ J	VR1, VR2 Semifixed (100Ω) R1, R2, R5, R6, R15-R26, R29, R30, R33, R34, R45-R60, R65-R68, R77-R84, R89, R90, R95-R98, R107-R110, R115-R120
	RD%PM □□□ JNL	R3, R4, R9-R12
	RD%PMF □□□ J	R35-R38, R63, R64, R69-R72, R93, R94, R113, R114
	RD%PMFL □□□ J	R31, R32, R39-R44, R61, R62, R91, R92, R121, R122
	RD%PS □□□ J	R73-R76
	RD%PSF □□□ J	R111, R112
★	TH102-2	TH1, TH2
★	TH103-2	TH3, TH4

SEMICONDUCTORS

Mark	Part No.	Symbol & Description
★★	2SK129A	Q1, Q2
★★	2SC2291	Q3, Q4
★★	2SA979	Q5, Q6
★★	2SC2259	Q9, Q10
★★	2SA733A (2SA1115/A/) (2SA992)	Q11, Q12
★★	2SA905A	Q13, Q14
★★	2SC1915A (2SC1915)	Q15, Q16
★★	2SC2603/A/ (2SC1400)	Q17, Q18, Q23, Q24
★★	2SA1115/A/ (2SA750)	Q19-Q22
★★	2SA893A	Q25, Q26
★★	2SC1890A	Q27, Q28
★★	2SC2275	Q29, Q30
★★	2SA985	Q31, Q32
★★	2SB507P (2SB834) (2SB682)	Q101
★★	2SD313P (2SD880) (2SD712)	Q102
★★	NJM4558DX (μPC4558C-P)	Q33
★	MZ-047	D21-D24
★	MZ-150 (WZ-150)	D33
★	MZL240	D101, D102
★	1S2471	D43-D46
★	1S1555 (1S2473) (1S2076) (US1035)	D1-D4, D7, D8, D13-D20, D25-D28, D39-D42
★	STV2H-0	D11, D12

POWER AMPLIFIER ASSEMBLY (AWH-112)

Parts List of AWH-112 (for HE and HB types)

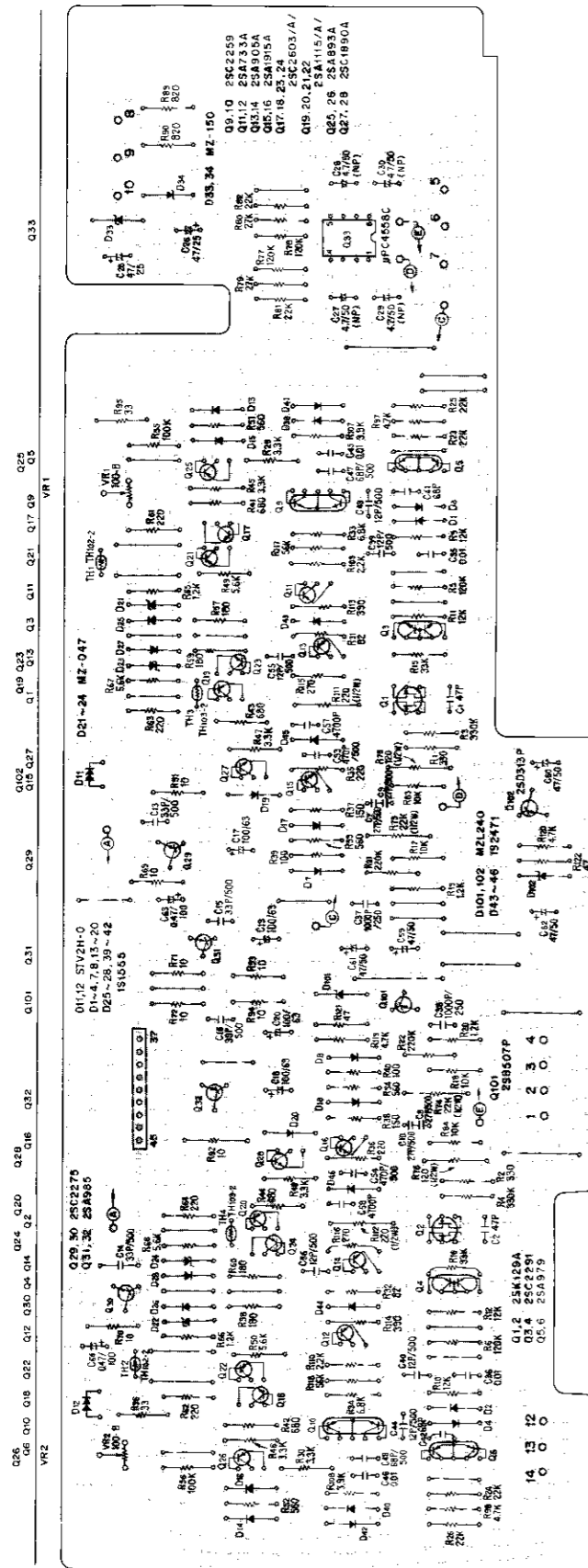

CAPACITORS

Mark	Part No.	Symbol & Description
	ACH-359 (CEXANP 4R7M 50)	C27-C30 Electrolytic (4,7/50V NP)
	CEA R47M 100L	C63, C64
	CEA 470M 25L	C25, C26
	CEA 470M 50L	C59-C62
	CCDSL 270K 500	C7-10
	CEA 101M 63L	C17-C20
	CCDSL 120K 500	C39, C40, C43
	CCDSL 120K 500	C44, C55, C56
	CCDSL 330K 500	C13-C16
	CCDSL 680K 500	C47, C48
	CCDSL 470J 50	C1, C2
	CCDSL 680J 50	C41, C42
	CKDYB 472K 50	C57, C58
	CKDYB 471K 500	C53, C54
	CKDYF 103Z 50	C35, C36, C45, C46
	CQMA 102K 250	C37, C38

SEMICONDUCTORS

Mark	Part No.	Symbol & Description
★★	2SK129A	Q1, Q2
★★	2SC2291	Q3, Q4
★★	2SA979	Q5, Q6
★★	2SC2259	Q9, Q10
★★	2SA733A (2SA1115/A/) (2SA992)	Q11, Q12
★★	2SA905A	Q13, Q14
★★	2SC1915A (2SC1915)	Q15, Q16
★★	2SC2603/A/ (2SC1400)	Q17, Q18, Q23, Q24
★★	2SA1115/A/ (2SA750)	Q19-Q22
★★	2SA893A	Q25, Q26
★★	2SC1890A	Q27, Q28
★★	2SC2275	Q29, Q30
★★	2SA985	Q31, Q32
★★	2SB507P (2SB834) (2SB682)	Q101
★★	2SD313P (2SD880) (2SD712)	Q102
★★	NJM4558DX (μPC4558C-P)	Q33
★	MZ-047	D21-D24
★	MZ-150 (WZ-150)	D33
★	MZL240	D101, D102
★	1S2471	D43-D46
★	1S1555 (1S2473) (1S2076) (US1035)	D1-D4, D7, D8, D13-D20, D25-D28, D39-D42
★	STV2H-0	D11, D12

RESISTORS

Note: When ordering resistors, convert the resistance value into code form, and then rewrite the part no. as before.

Mark	Part No.	Symbol & Description
★	ACP-019 RD%PM □□□J	VR1, VR2 Semifixed (100Ω) R1, R2, R5, R6, R15-R26, R29, R30, R33, R34, R45-R60, R65-R68, R77-R84, R89, R90, R95-R98, R107-R110, R115-R120
	RD%PM □□□ JNL	R3, R4, R9-R12
	RD%PMF □□□ J	R31, R32, R35-R44, R61-R64, R69-R72, R91-R94, R113, R114, R121, R122
	RD%PS □□□ J	R73-R76
	RD%PSF □□□ J	R111, R112
★	TH101-2	TH1, TH2
★	TH103-2	TH3, TH4

SCHEMATIC DIAGRAMS

For KU and KC types

A

B

C

D

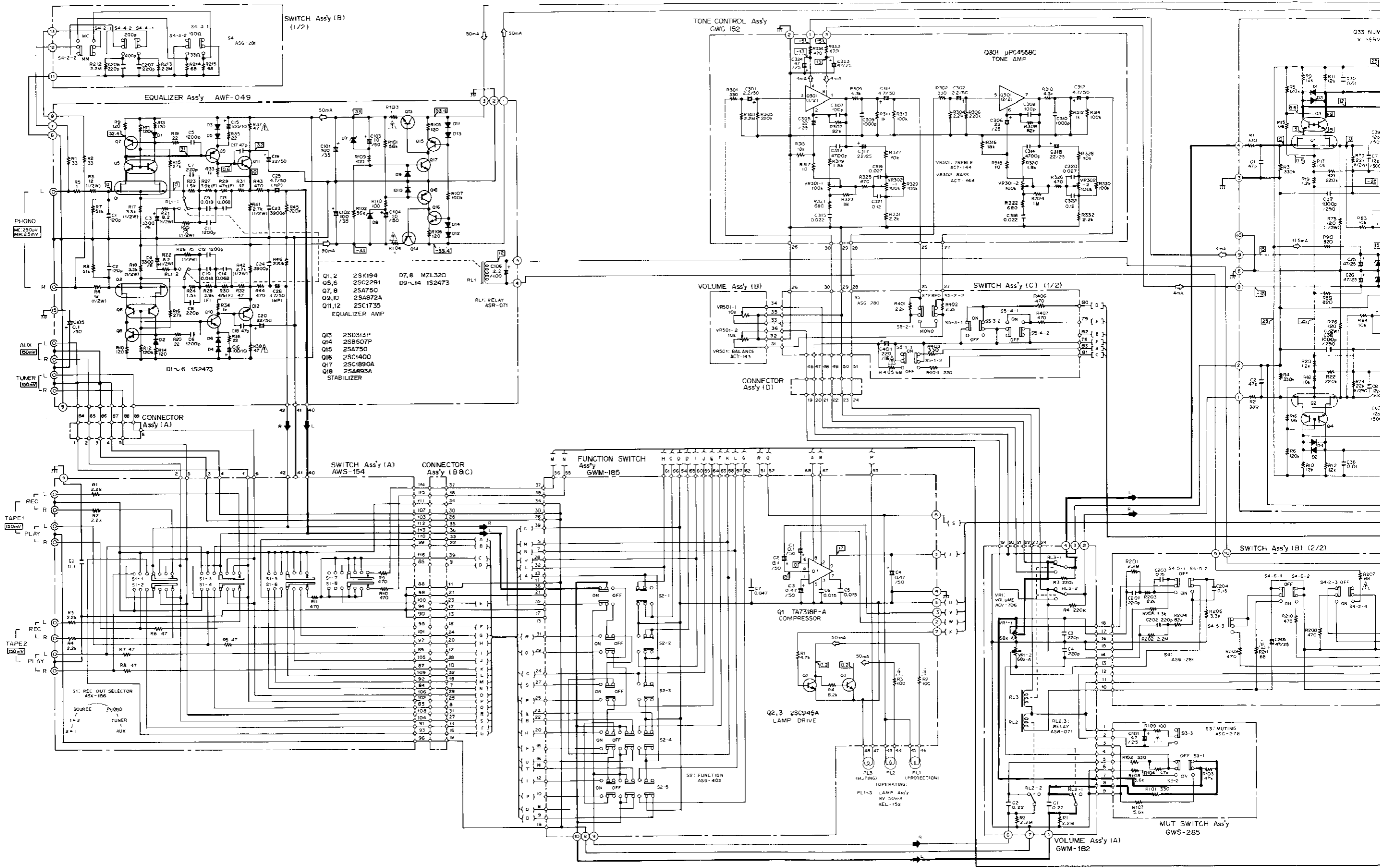

NOTE:
 The indicated semiconductors are representative ones only. Other alternative semiconductors may be used and are listed in the parts list.

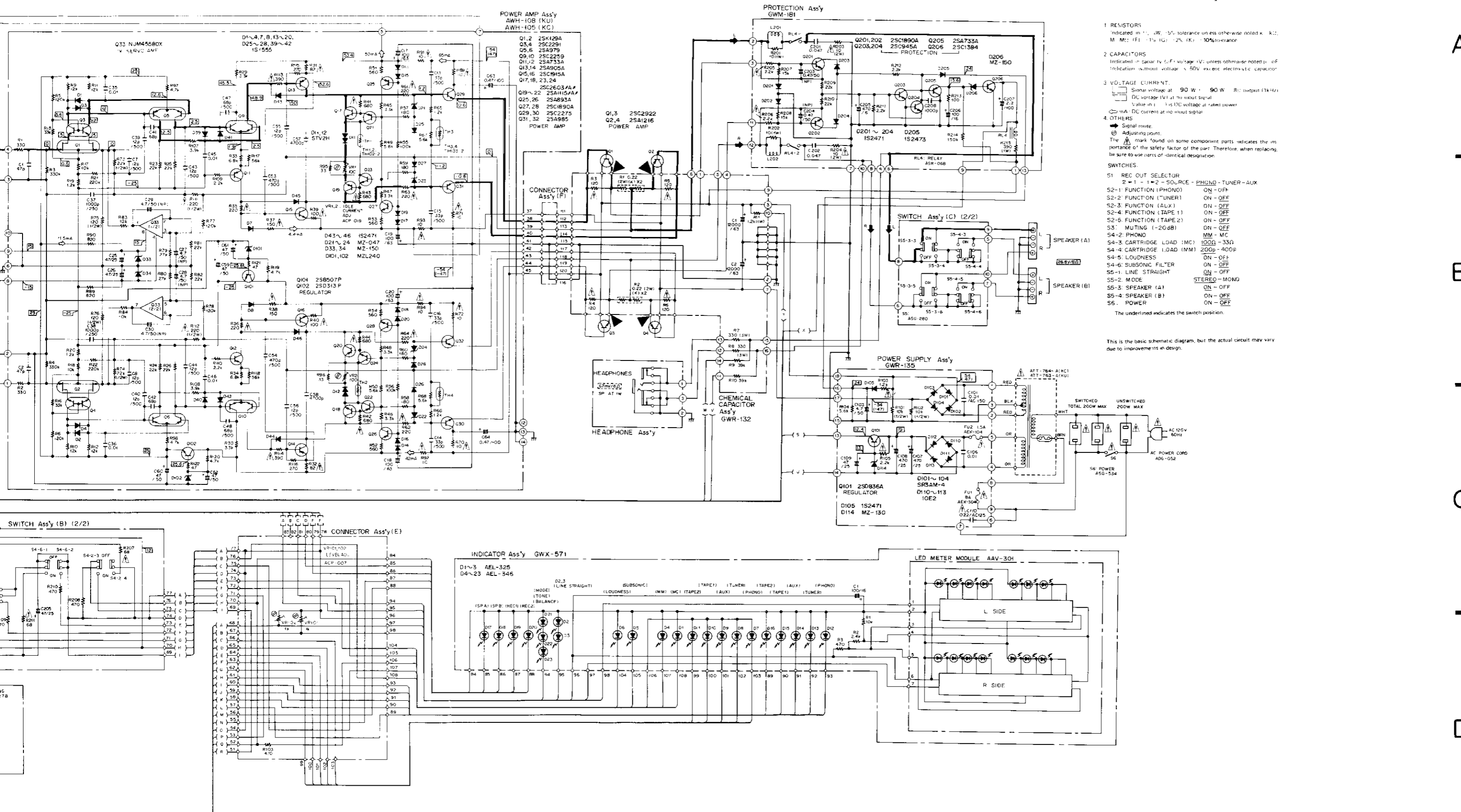

- 1 RESISTORS**
 Indicated in Ω, μW, 5% tolerance unless otherwise noted. K, K; M, M; (F) 1%, (G) 2%, (K) 10% tolerance.
- 2 CAPACITORS**
 Indicated in pF, μF, voltage (V); unless otherwise noted, μF indication without voltage is 50V except electrolytic capacitor.
- 3 VOLTAGE CURRENT**
 Signal voltage at 90 W, 90 W R; output (1kHz)
 DC voltage (V) at no input signal
 Value in () is DC voltage at rated power
 mA, DC current at no input signal
- 4 OTHERS**
 Signal route
 Adjusting point
 The mark found on some component parts indicates the importance of the safety factor of the part. Therefore, when replacing, be sure to use parts of identical designation.
- SWITCHES:**
- | | | | | |
|------|---------------------|---------------|-----|------------------------------|
| S1 | REC OUT SELECTOR | 2-1-1 | 2-2 | SOURCE - PHONO - TUNER - AUX |
| S2-1 | FUNCTION (PHONO) | ON - OFF | | |
| S2-2 | FUNCTION (TUNER) | ON - OFF | | |
| S2-3 | FUNCTION (AUX) | ON - OFF | | |
| S2-4 | FUNCTION (TAPE 1) | ON - OFF | | |
| S2-6 | FUNCTION (TAPE 2) | ON - OFF | | |
| S5 | MUTING (-20dB) | ON - OFF | | |
| S4-2 | PHONO | NM - MC | | |
| S4-3 | CARTRIDGE LOAD (MC) | 100Ω - 33Ω | | |
| S4-4 | CARTRIDGE LOAD (MM) | 200Ω - 400Ω | | |
| S4-5 | LOUDNESS | ON - OFF | | |
| S4-6 | SUBSONIC FILTER | ON - OFF | | |
| S5-1 | LINE STRAIGHT | ON - OFF | | |
| S5-2 | MODE | STEREO - MONO | | |
| S5-3 | SPEAKER (A) | ON - OFF | | |
| S5-4 | SPEAKER (B) | ON - OFF | | |
| S6 | POWER | ON - OFF | | |
- The underlined indicates the switch position.
- This is the basic schematic diagram, but the actual circuit may vary due to improvements in design.

For HE and HB types

A

B

C

D

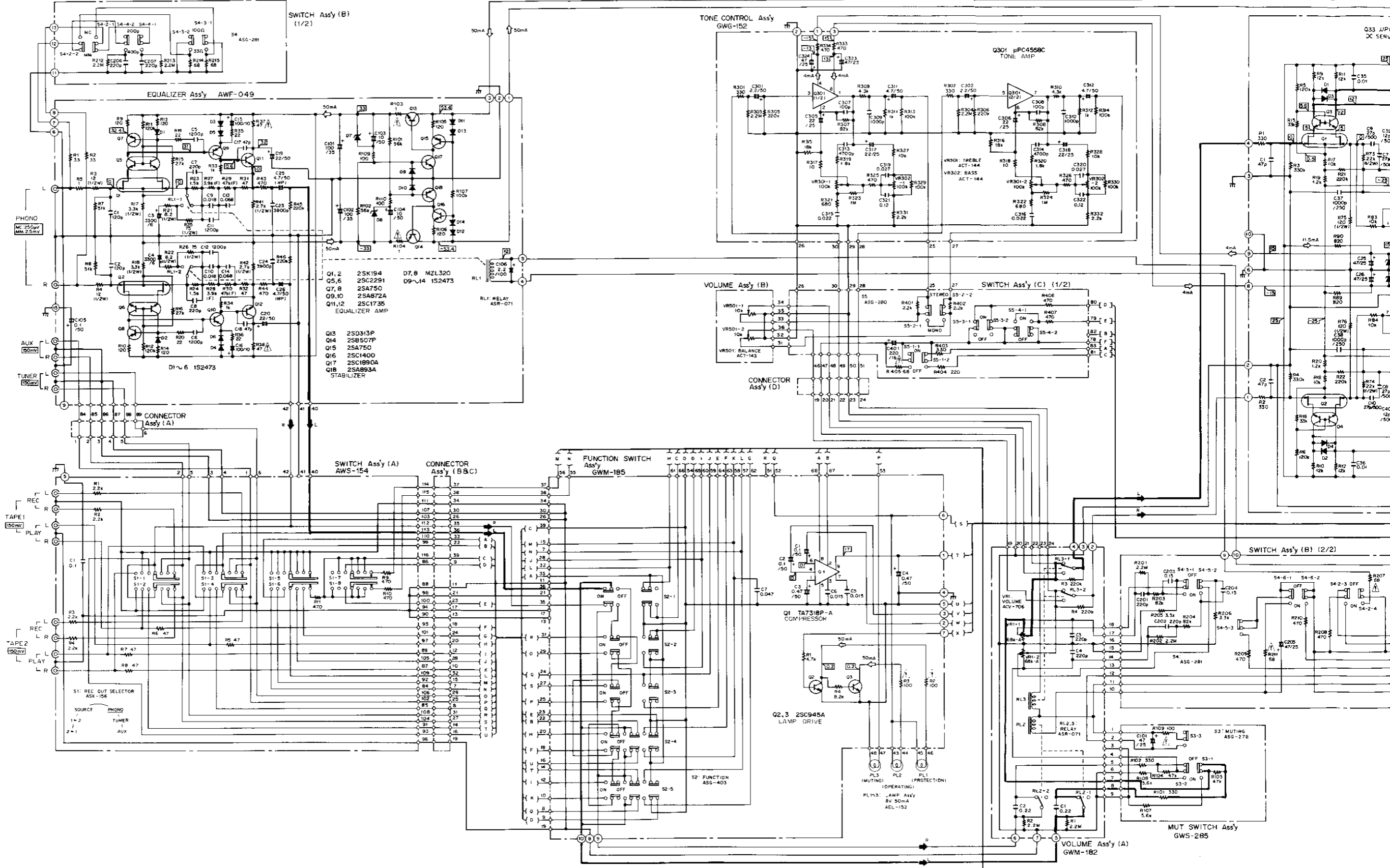

1

2

3

4

5

6

NOTE:
 The indicated semiconductors are representative ones only. Other alternative semiconductors may be used and are listed in the parts list.

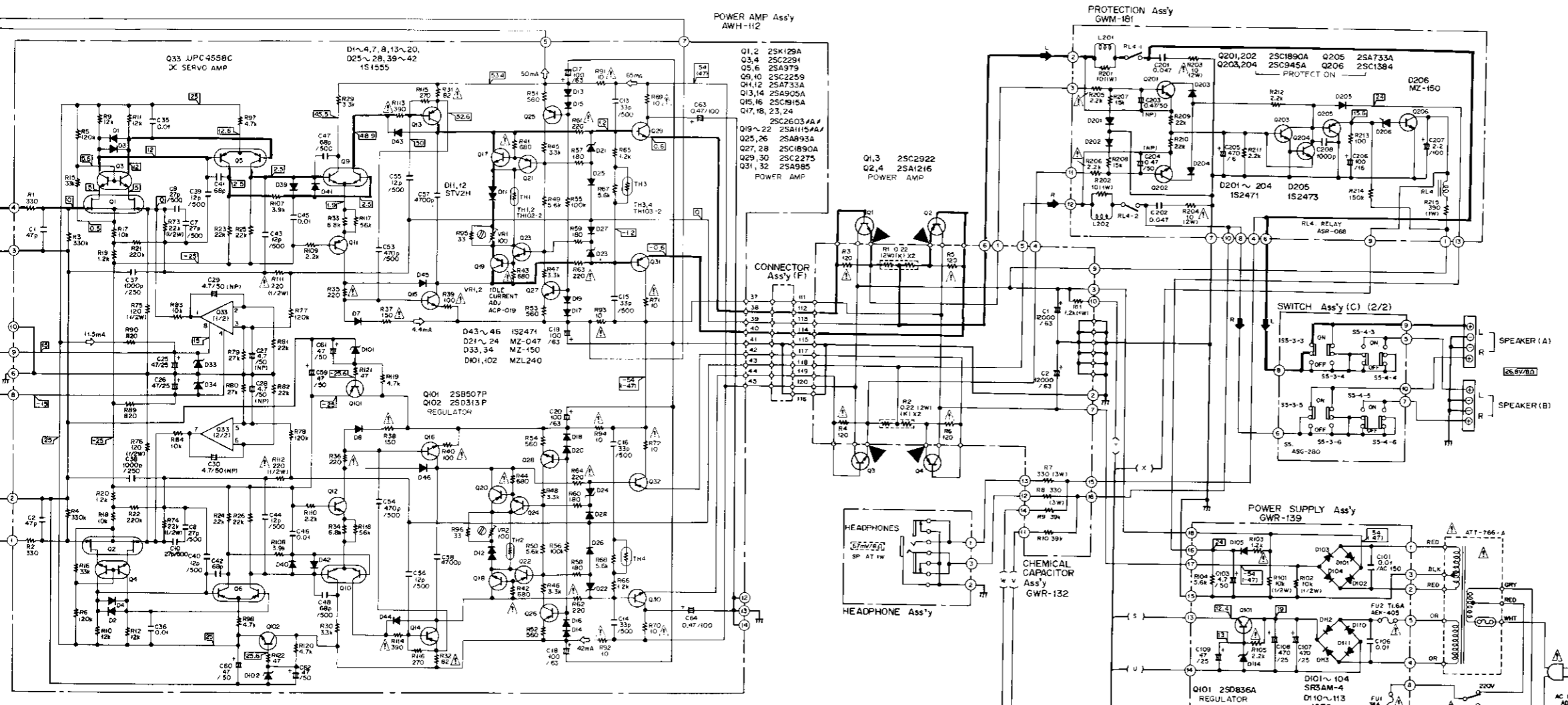

- RESISTORS**
 Indicated in Ω, K, M, % tolerance unless otherwise noted. k = 10³, M = 10⁶, (F) = 1%, (G) = 2%, (K) = 10% tolerance.
 - CAPACITORS**
 Indicated in capacity (μF) voltage (V) unless otherwise noted. μ = indication without voltage is 50V except electrolytic capacitor.
 - VOLTAGE CURRENT**
 Signal voltage at 90 W + 90 W 8: output (1kHz)
 DC voltage (V) at no input signal
 Value in i = i.s DC voltage at rated power
 mA = DC current at no input signal
 - OTHERS**
 Signal route
 Adjusting point
 The mark found on some component parts indicates the importance of the safety factor of the part. Therefore, when replacing, be sure to use parts of identical designation.
- SWITCHES**
- | | |
|--------------------------|--|
| S1 REC. OUT. SELECTOR | 2 = 1 - 1 = 2 - SOURCE - PHONO - TUNER - AUX |
| S2-1 FUNCTION (PHONO) | ON - OFF |
| S2-2 FUNCTION (TUNER) | ON - OFF |
| S2-3 FUNCTION (AUX1) | ON - OFF |
| S2-4 FUNCTION (TAPE 1) | ON - OFF |
| S2-5 FUNCTION (TAPE 2) | ON - OFF |
| S3 MUTING (-20dB) | ON - OFF |
| S4-2 PHONO | MM - MC |
| S4-3 CARTRIDGE LOAD (MC) | 100Ω - 33Ω |
| S4-4 CARTRIDGE LOAD (MM) | 200Ω - 400Ω |
| S4-5 LOUDNESS | ON - OFF |
| S4-6 SUBSONIC FILTER | ON - OFF |
| S5-1 LINE STRAIGHT | ON - OFF |
| S5-2 MODE | STEREO - MONO |
| S5-3 SPEAKER (A) | ON - OFF |
| S5-4 SPEAKER (B) | ON - OFF |
| S6 POWER | ON - OFF |
| S7 LINE VOLTAGE SELECTOR | 220V - 240V |
- The underlined indicates the switch position.

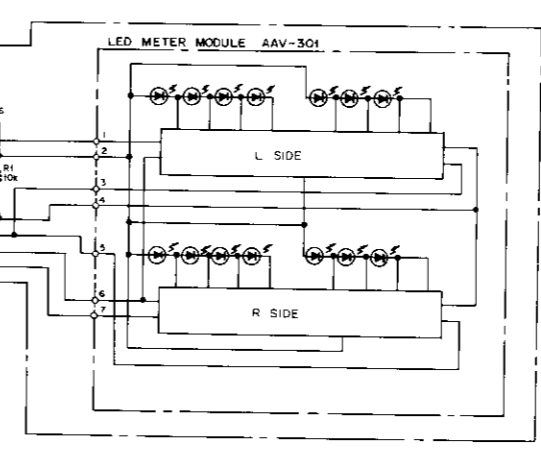
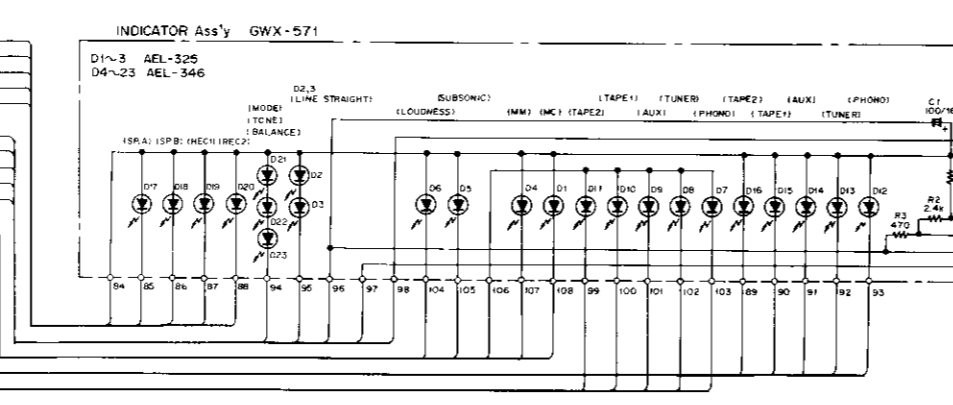
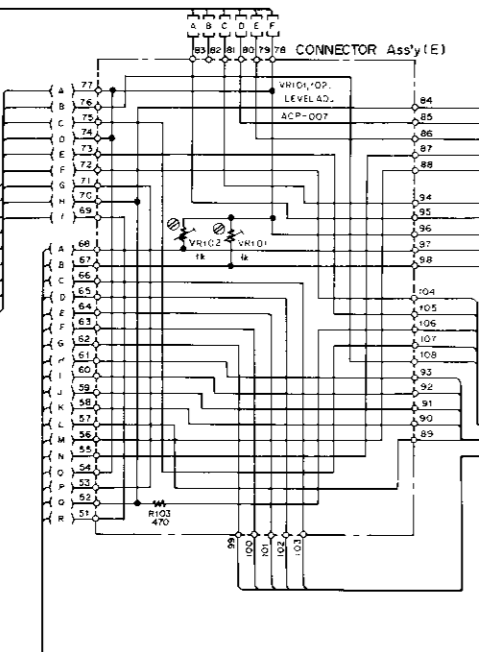
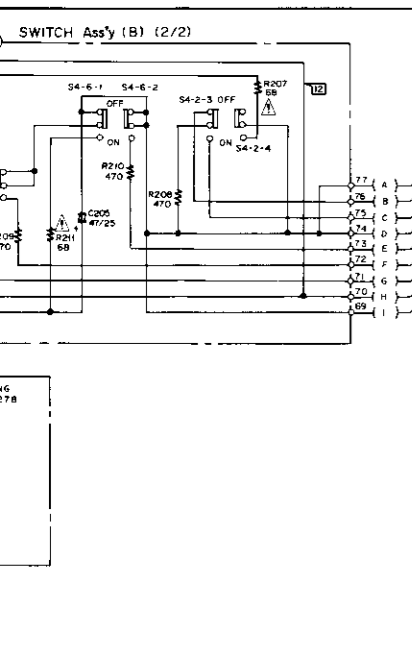
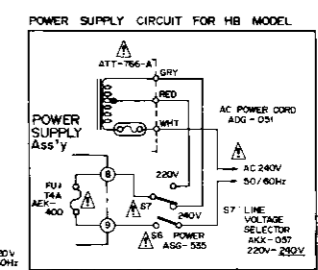

A
 B
 C
 D

For S and S/G types

A

B

C

D

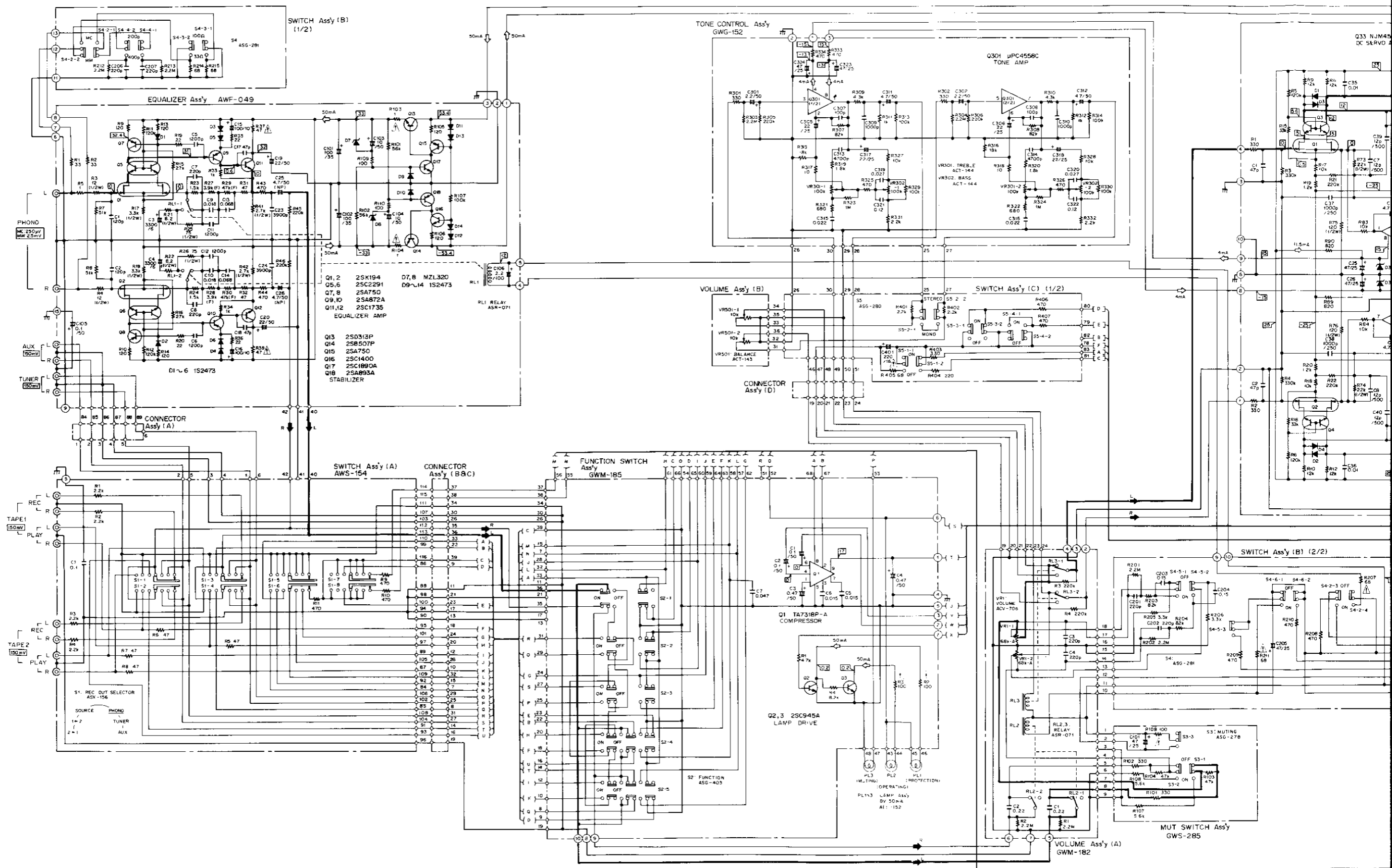

NOTE:
 The indicated semiconductors are representative ones only. Other alternative semiconductors may be used and are listed in the parts list.

