

 **PIONEER**

# Service Manual

**CIRCUIT DESCRIPTIONS  
REPAIR & ADJUSTMENTS**

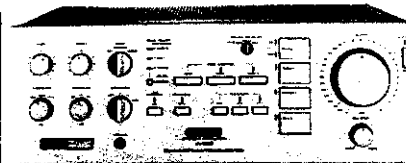

**ORDER NO.  
ARP-344-0**

**STEREO AMPLIFIER**

# A-90

- This service manual is applicable to the KU type.

## CONTENTS

1. SPECIFICATIONS .....	2	8. SCHEMATIC DIAGRAM .....	27
2. FRONT PANEL FACILITIES .....	3	9. ELECTRICAL PARTS LIST .....	33
3. BLOCK DIAGRAM .....	5	10. ADJUSTMENTS .....	40
4. CIRCUIT DESCRIPTIONS .....	7	11. SAFETY INFORMATION .....	41
5. PARTS LOCATION .....	10	12. PACKING .....	42
6. EXPLODED VIEWS AND PARTS LIST .....	13		
7. P.C. BOARDS CONNECTION DIAGRAM .....	19		

**PIONEER ELECTRONIC CORPORATION** 4-1, Meguro 1-Chome, Meguro-ku, Tokyo 153, Japan  
**PIONEER ELECTRONICS (USA) INC.** 1925 E. Dominguez St., Long Beach, California 90810 U.S.A.  
**PIONEER ELECTRONIC (EUROPE) N.V.** Keetberglaan 1, 2740 Beveren, Belgium  
**PIONEER ELECTRONICS AUSTRALIA PTY. LTD.** 178-184 Boundary Road, Braeside, Victoria 3195, Australia

# 1. SPECIFICATIONS

## Amplifier Section

Continuous Average Power Output is 200 watts\* per channel, min., at 8 ohms from 20 Hertz to 20,000 Hertz with no more than 0.002 % total harmonic distortion.\*\*

Continuous Power Output at 1kHz (both channel driven)  
 T. H. D. 0.002%, 8 ohms . . . . . 220watts per channel  
 Total Harmonic Distortion (20 Hertz to 20,000 Hertz, 8 ohms)

continuous rated power output  
 . . . . . \*\*No more than 0.002%  
 100 watts per channel power output  
 . . . . . \*\*No more than 0.002%

Intermodulation Distortion (50 Hertz: 7,000 Hertz = 4 : 1, 8 ohms)  
 continuous rated power output  
 . . . . . No more than 0.002%

Damping Factor (20 Hertz to 20,000 Hertz, 8 ohms)  
 . . . . . 100

Input (Sensitivity/Impedance)  
 PHONO MM . . . . . 2.5mV/50 kilohms  
 PHONO MC . . . . . 150µV/100 ohms, 33 ohms  
 TUNER, CD/AUX1, AUX2, TAPE PLAY 1, 2  
 . . . . . 150 mV/50 kilohms

Phono Overload Level (T.H.D. 0.008%, 1,000Hz)  
 PHONO MM . . . . . 300mV  
 PHONO MC . . . . . 18mV

Output Level/Impedance  
 TAPE REC 1, 2 . . . . . 150mV/2.2 kilohms

Frequency Response  
 PHONO MM (RIAA Equalization)  
 . . . . . 20Hz to 100,000Hz±0.2dB  
 TUNER, CD/AUX1, AUX2, TAPE PLAY 1, 2  
 . . . . . 5Hz to 100,000Hz±0.3dB

Tone Control  
 BASS . . . . . ±6dB (100Hz) at 200Hz Position  
 . . . . . Turnover frequency: 100Hz/200Hz/400Hz  
 TREBLE . . . . . ±6dB (10kHz) at 4kHz Position  
 . . . . . Turnover frequency: 2kHz/4kHz/8kHz

Filter  
 LOW (SUBSONIC) . . . . . 15Hz (-6dB/oct.)  
 Hum and Noise (IHF, short circuited A network)  
 PHONO MM . . . . . 89dB  
 PHONO MC . . . . . 74dB  
 TUNER, CD/AUX1, AUX2, TAPE PLAY 1, 2 . . . . . 113dB  
 Muting . . . . . -20dB

## Miscellaneous

Power Requirements . . . . . 120V, 50/60Hz  
 Power Consumption . . . . . 350 W (UL)  
 Dimensions . . . . . 420(W) x 150(H) x 420(D) mm  
 . . . . . 16-9/16(W) x 5-7/8(H) x 16-9/16(D) in  
 Weight (without package) . . . . . 19.6kg (43 lb 3 oz)

## Furnished Parts

Operating Instructions . . . . . 1

\*Measured pursuant to the Federal Trade Commission's Trade Regulation rule on Power Output Claims for Amplifier.

\*\*Measured by Shibasoku 725 Automatic Distortion Analyzer.

NOTE:  
 Specifications and design subject to possible modification without notice.

## QUESTIONNAIRE

## MODEL

One Model per questionnaire

Dear Servicer,

Thank you for your cooperation in the post-sale service of Pioneer products.

This questionnaire is used as a tool to improve the serviceability of our products and service manuals. Please evaluate this model and service manual by answering the following questions. Your ideas may be realized in our future products. Your answers will be appreciated. Thank you.

PIONEER ELECTRONIC CORP.

T. Nakagawa, Manager, Service Section, International Division

1. SERVICING EVALUATION	Circle applicable number:	Good	Fair	Poor		
a. Disassembly/Re-assembly:		1	2	3	*4	*5
b. Circuit Checks:		1	2	3	*4	*5
c. Replacement of Parts:		1	2	3	*4	*5
d. Adjustment (s):		1	2	3	*4	*5

\* If (4) or (5) was circled, please be specific.

e. Your advice, opinion or ideas related to servicing this product.

**2. SERVICE MANUAL EVALUATION**

a. Circuit & Mechanism Description

b. Circuit Diagram

**3. OTHER**

Please describe other areas of servicing which you may find difficult.

Completed by :

Date :

Company Name :

Address :

City/State/Zip :

Please send this form filled to the distributor in your country.

## 2. FRONT PANEL FACILITIES

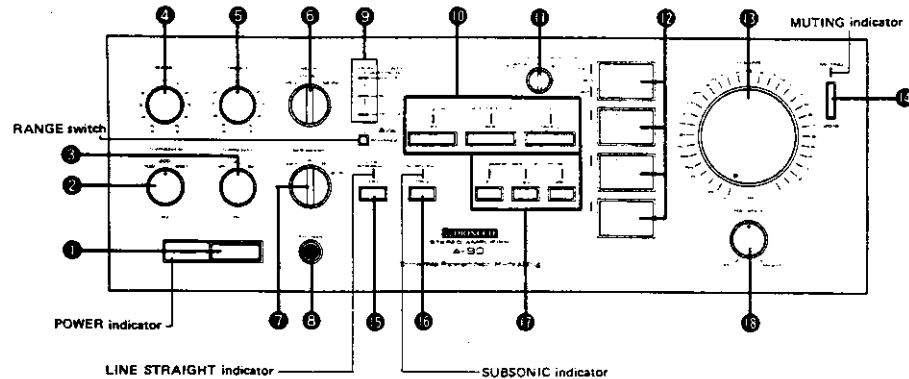

### 1 POWER SWITCH

Power is supplied to the stereo amplifier when the switch is depressed, and the power indicator changes from red to green. The power is turned off when the switch is released to the OFF position.

### 2 BASS TURNOVER CONTROL

This is used to select the frequency at which the BASS control starts to have an effect on the tone quality when it is used for adjustment.

- 400 . . . . . Allows the frequency band below 400Hz to be adjusted.
- 200 . . . . . Allows the frequency band below 200Hz to be adjusted.
- 100 . . . . . Allows the frequency band below 100Hz to be adjusted.

### 3 TREBLE TURNOVER CONTROL

This is used to select the frequency at which the TREBLE control starts to have an effect on the tone quality when it is used for adjustment.

- 2k . . . . . Allows the frequency band above 2kHz to be adjusted.
- 4k . . . . . Allows the frequency band above 4kHz to be adjusted.
- 8k . . . . . Allows the frequency band above 8kHz to be adjusted.

### 4 BASS CONTROL

This is used to adjust the BASS (low frequency range) sound. When the control is turned clockwise, the level of sound below the frequency selected by the BASS TURNOVER control is emphasised. Conversely, when the control is turned counter-clockwise (⊖) from the "0" position, the level of sound below the frequency selected by the BASS TURNOVER control is attenuated.

**NOTE:**

The control does not operate if the LINE STRAIGHT switch is ON.

### 5 TREBLE CONTROL

This is used to adjust the TREBLE (high frequency range) sound. When the control is turned clockwise, the level of sound above the frequency selected by the TREBLE TURNOVER control is emphasised. Conversely, when the control is turned counter-clockwise (⊖) from the "0" position, the level of sound above the frequency selected by the TREBLE TURNOVER control is attenuated.

**NOTE:**

The control does not operate if the LINE STRAIGHT switch is ON.

### 6 MODE SELECTOR

This is used to select the mode.

- REV . . . . . Set here to shunt the left channel and right channel stereo input signals and listen in stereo.
- STEREO . . . . . Set here for ordinary stereo listening.
- MONO . . . . . Set here to mix the left and right channel stereo input signals and hear them in mono through both the left and right speakers.

**NOTE:**

The MODE selector does not function when the LINE STRAIGHT switch is in ON position.

### 7 SPEAKER SWITCHES

- OFF . . . . . There is no output signal from either A or B output terminals.
- A . . . . . Sound is heard from the speakers connected to SPEAKERS A terminals.
- B . . . . . Sound is heard from the speakers connected to SPEAKERS B terminals.
- A + B . . . . . Sound is heard from the speakers connected to both SPEAKERS A and B terminals.

### 8 PHONES JACKS

Connect the plug on your headphones to this jack. To listen to a program through the headphones, turn the SPEAKER switches to OFF.

### 9 PEAK POWER WATTS/8Ω INDICATOR

This indicates the output level at 6 stages, when speakers with a nominal impedance of 8 ohm are connected to the SPEAKERS terminals. (When the SPEAKER switches are OFF, it does not light up)

The RANGE SWITCH functions as follows

- : When released, it indicates the high level output (200, 50, 15) in watts.
- ▲ : When depressed, it indicates the low level output (5, 1, 0.3) in watts.

### 10 TAPE MONITOR SWITCHES

Used to play back a tape or monitor a recording.

- TAPE 1 . . . . . Depress to play back a tape or monitor a recording on the tape deck connected to TAPE 1 PLAY terminals.
- TAPE 2 . . . . . Depress to play back a tape or monitor a recording on the tape deck connected to TAPE 2 PLAY terminals.
- OFF . . . . . Depress if not playing back a tape or monitoring a recording.

**NOTE:**

Simultaneous playback or monitoring on TAPE 1 and TAPE 2 is not possible. Always be careful to depress the TAPE MONITOR switch properly. If the switch is not depressed, both of the indicators for TAPE 1 and TAPE 2 light up and no sound is heard.

### 11 PHONO SELECTOR

To play a record on the turntable, adjust either MC or MM depending on the cartridge being used. When using an MC (Moving Coil) Cartridge, position at MC (100Ω or 33Ω).

### 12 FUNCTION SWITCH

This is used to select the program source. At the left of each switch is a FUNCTION indicator, which lights up when the corresponding function has been selected.

- PHONO . . . . . Depress for playing records on a turntable connected to the PHONO terminals.
- TUNER . . . . . Depress for listening to a broadcast on a tuner connected to the TUNER terminals.
- CD/AUX1 . . . . . Depress for listening to the sound from a stereo component connected to the CD/AUX1 jacks.
- AUX2 . . . . . Depress for listening to the sound from a stereo component connected to the AUX2 jacks.

### 13 VOLUME CONTROL

This is used to adjust the volume of sound heard through the speakers or headphones. The scale shows the attenuation of the dB display. No sound is heard when the control is set at "∞". Turn slowly in a clockwise direction (⊙).

### 14 MUTING - 20dB SWITCH

The volume is attenuated by 20dB when this switch is depressed to the ON position (MUTING indicator lights up). The switch can be used effectively when the stylus descends onto the record during record play, when the sound is to be turned down temporarily and when you want to adjust the sound precisely as you listen to a program source under low sound level conditions.

### 15 LINE STRAIGHT SWITCH

When the switch is depressed to OFF position (the LINE STRAIGHT indicator goes out), the signal from the input jacks passes through the Balance mode and the tone control circuits and the tone quality can be adjusted using the TREBLE and BASS controls. When the switch is depressed once again to ON position (LINE STRAIGHT indicator lights up), the signal from the input jacks is sent directly to the Power Amplifier, without passing through the balance mode and tone control circuits and a flat frequency is obtained.

### 16 SUBSONIC FILTER SWITCH

When the switch is depressed to the ON position, the subsonic filter with the 15Hz cut off frequency operates. The subsonic filter attenuates frequencies lower than 15Hz with a 6dB/oct slope, and can be used, therefore, to suppress the ultra-low range noise, which is generated by record warp and other factors. This noise cannot actually be heard by the ear, but it can cause intermodulation distortion and even damage to the speaker systems. When playing badly warped records, this switch can be used to good effect.

### 17 TAPE COPY SWITCHES

Use these switches when copying a tape, using 2 tape decks.

- 1 ▶ 2 . . . . . Depress when copying a tape (recording) from tape deck 1 to 2.
- 2 ▶ 1 . . . . . Depress when copying a tape (recording) from tape deck 2 to 1.
- OFF . . . . . Depress when not copying. Leave in the OFF position normally.

### 18 BALANCE CONTROL

Used to adjust the balance of sound from the left and right channels. To increase the volume from the right channel, turn in a clockwise direction from the centre (⊙). To increase the volume from the left channel, turn in a counter-clockwise direction from the center (⊙). The control does not function if the LINE STRAIGHT switch is ON.

### 3. BLOCK DIAGRAM

A

A

B

B

C

C

D

D

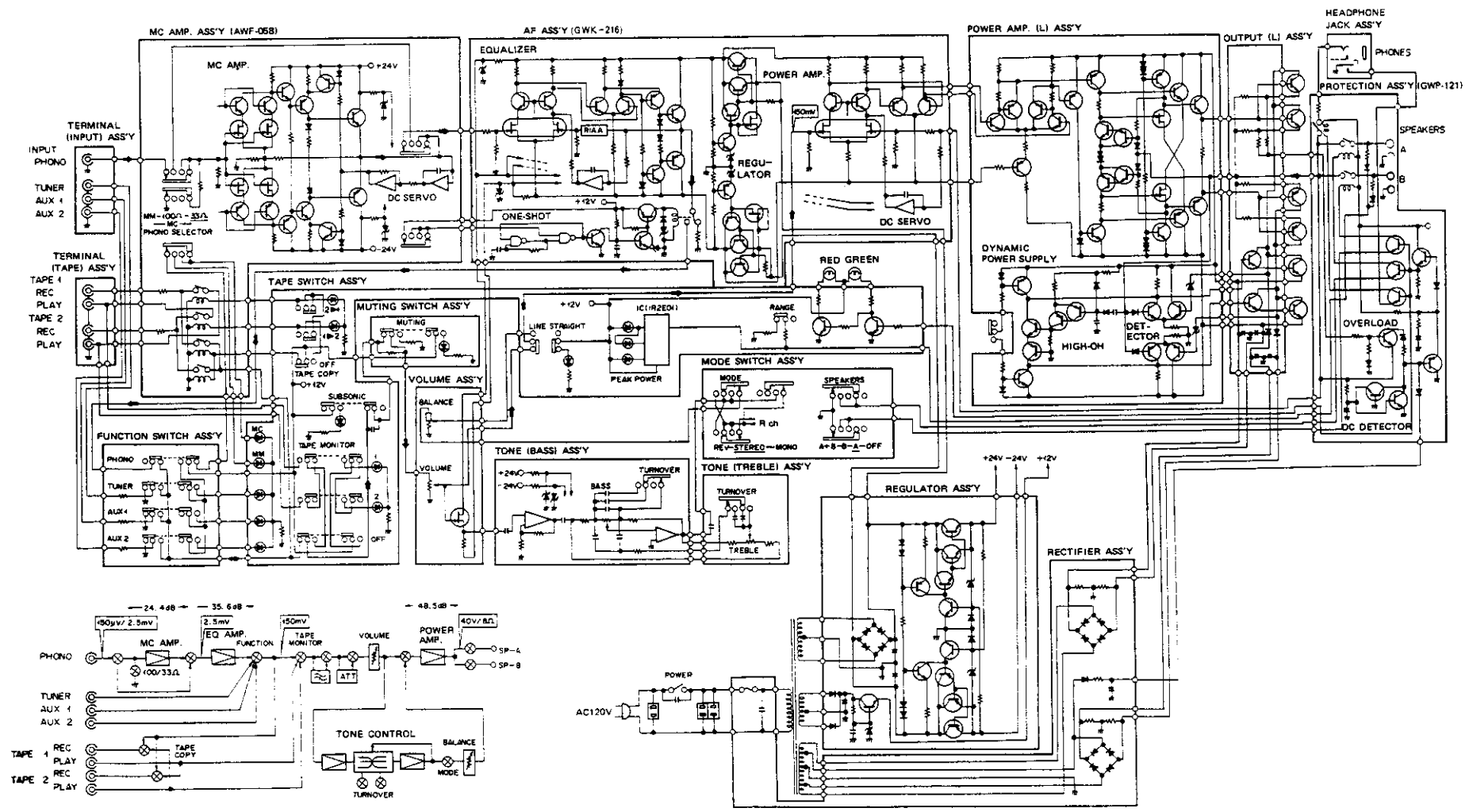

## 4. CIRCUIT DESCRIPTIONS

### 4.1 OUTLINE OF MAIN CIRCUITS

#### MC Head Amplifier

This is an input-parallel positive/negative DC amplifier with DC servo controlling the stage 3 bias circuit to prevent deterioration in the signal-to-noise ratio when the signal level is very low. The amplifier gain is 24.4dB and the S-to-N ratio is 74dB (150 $\mu$ V input).

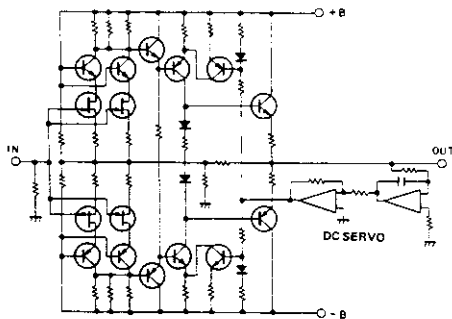

Fig. 4-1 MC head amplifier

#### Equalizer Amplifier

The use of an input stage FET and DC servo control has eliminated the need for input/output coupling capacitors. Amplifier gain is 35.6dB (1kHz).

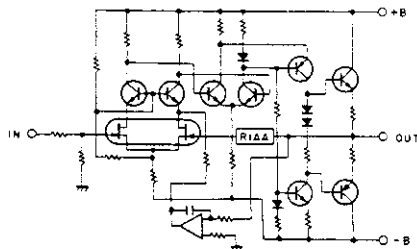

Fig. 4-2 Equalizer amplifier

#### Phono System Muting Circuit

Transient noise generated when the power is switched on and off, and the noise generated when the PHONO SELECTOR is switched are muted by a relay type muting circuit in the equalizer amplifier output (see Fig. 4-3).

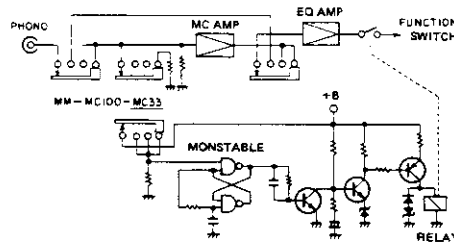

Fig. 4-3 Phono system muting circuit

#### Tone Control

NFB type tone control circuit with separate 3-step switchable turnover frequencies for low and high frequency regions.

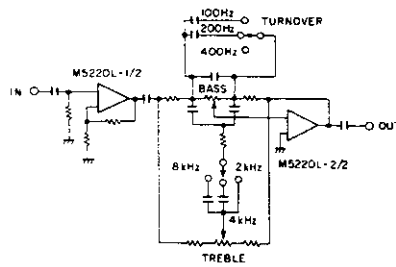

Fig. 4-4 Tone control

#### Line Straight Circuit

The LINE STRAIGHT switch in the A-90 simplifies the signal path by bypassing the tone control circuit, the mode switching circuit, and the balance control circuit. (See Fig. 4-5).

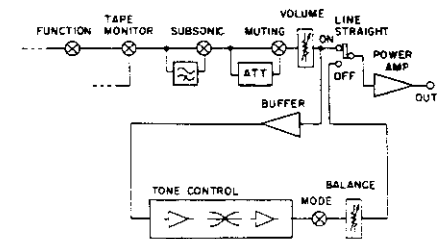

Fig. 4-5 LINE STRAIGHT circuit

#### Power Amplifier

The A-90 features high efficiency with a dynamic power supply system, high-speed bias servo control non-switching mechanism, and a first stage FET differential input and DC servo control DC amplifier system.

The FET buffer circuit between the voltage amplifier and power amplifier stages further reduces distortion and lessens the effects due to the load. (see Fig. 4-6).

The advantages of inserting the FET buffer between stages are enumerated below.

- (1) The power amplifier stage is set to constant voltage, thereby suppressing non-linearity in the hfe factor of the power transistor.
- (2) High loop gain stability unaffected by changes in the load.
- (3) Big reduction in the open-loop output impedance.
- (4) Power transistor driven at very low impedance, thereby reducing the effects of the storage carrier, and enabling high-speed operation.
- (5) With the very high load impedance at the predriver stage, distortion is minimal at high gain in this stage.

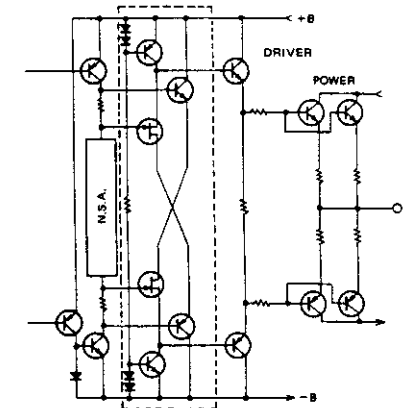

Fig. 4-6 FET Buffer

#### Protector Circuit

Standard protector circuit with bridge type overload detector, DC voltage detector, delayed relay action when the power is switched on, and rapid relay action when the power is switched off. Furthermore, a muting relay is also used in speaker switching. (see Fig. 4-7).

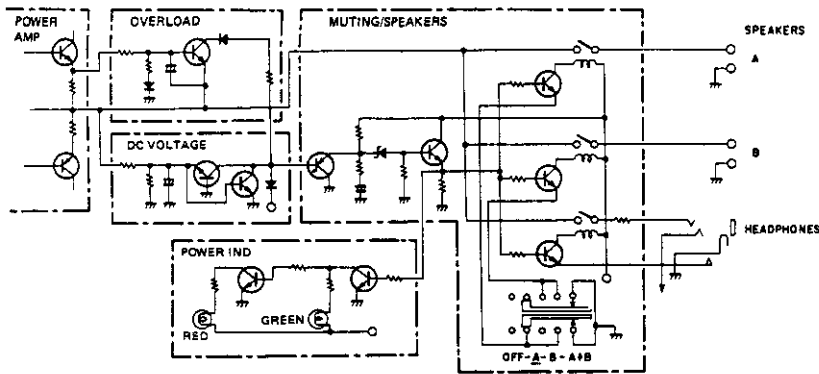

Fig. 4-7 Protector circuit

4.2 DYNAMIC POWER SUPPLY CIRCUIT

The dynamic power supply system featured in the final stage of the A-90 power amplifier varies the voltage applied to the power transistor in accordance to the signal level. The result is reduced heat loss and higher efficiency.

Operating Principles

The basic circuitry is outlined in Fig. 4-8. There are two power lines,  $V_H$  and  $V_L$ . The signal output  $u_a$  is compared with final stage power voltage  $u_a$  by differentiator,  $u_a$  being obtained by controlling  $V_H$ . With the  $u_a$  input applied to the differentiator being offset by  $E_s$  (several volts), the  $u_a$  waveform is traced,  $u_a$  being several volts larger than  $u_o$ . If, however,  $u_o$  is less than  $V_L - E_s$ ,  $u_a$  is fixed at the  $V_L$  level (see Fig. 4-9). The purpose of the high-region ON circuit is to avoid irregularities from occurring where  $u_a$  can no longer follow  $u_o$  at high signal frequencies, and to prevent high-speed continuous operation in the control transistor. That is, when high frequency signals appear at the output, the control transistors (Q3 and Q4) are turned fully on, and  $u_a$  is fixed at the  $V_H$  level.

A-90 Dynamic Power Supply Circuit

The overall circuit structure is outlined in Fig. 4-10.  $V_L$  is fixed so as to obtain the rated output (200W) for a  $4\Omega$  load, and the high region ON circuit is designed to operate at frequencies above 3kHz. The SPEAKER IMPEDANCE switch set to the  $4\Omega \sim 6\Omega$  position fixes the power supply to the final stage transistor at the  $V_L$  level.

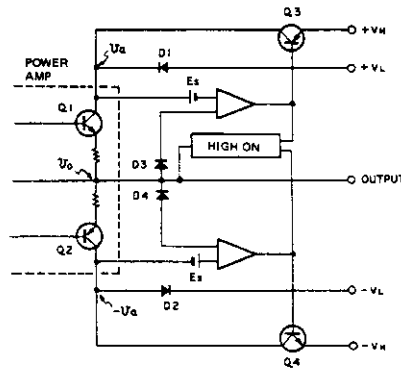

Fig. 4-8 Basic circuitry

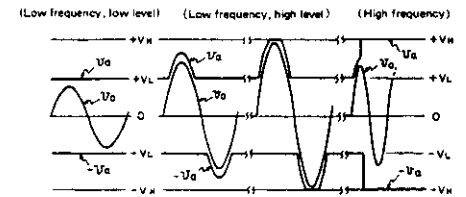

Fig. 4-9 Operating waveforms

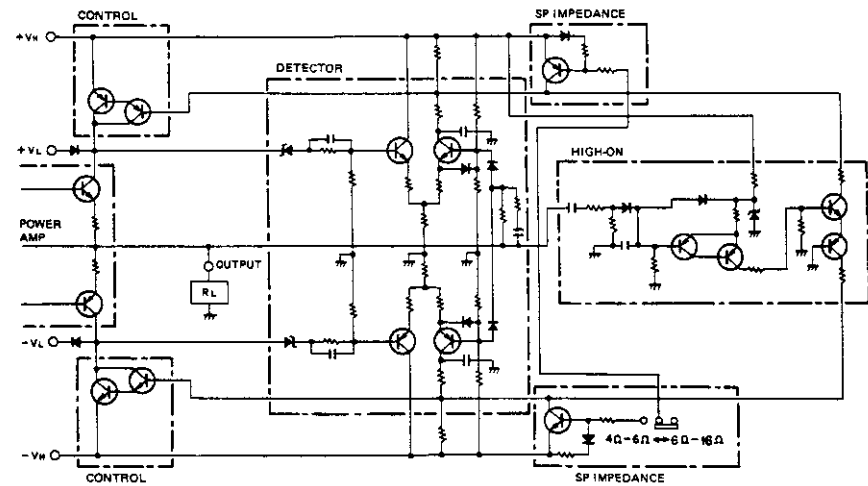

Fig. 10 Dynamic power supply circuit

5. PARTS LOCATION

NOTES:

- Parts without part number cannot be supplied.
- The  $\Delta$  mark found on some component parts indicates the importance of the safety factor of the part. Therefore, when replacing, be sure to use parts of identical designation.
- For your Parts Stock Control, the fast moving items are indicated with the marks  $**$  and  $*$ .  
 $**$  GENERALLY MOVES FASTER THAN  $*$ .  
 This classification shall be adjusted by each distributor because it depends on model number, temperature, humidity, etc.

**Front Panel**

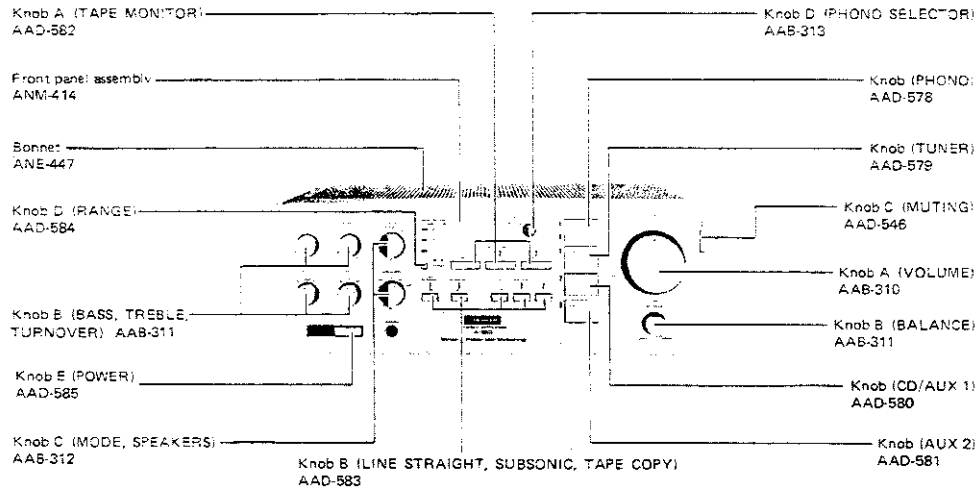

**Front View**

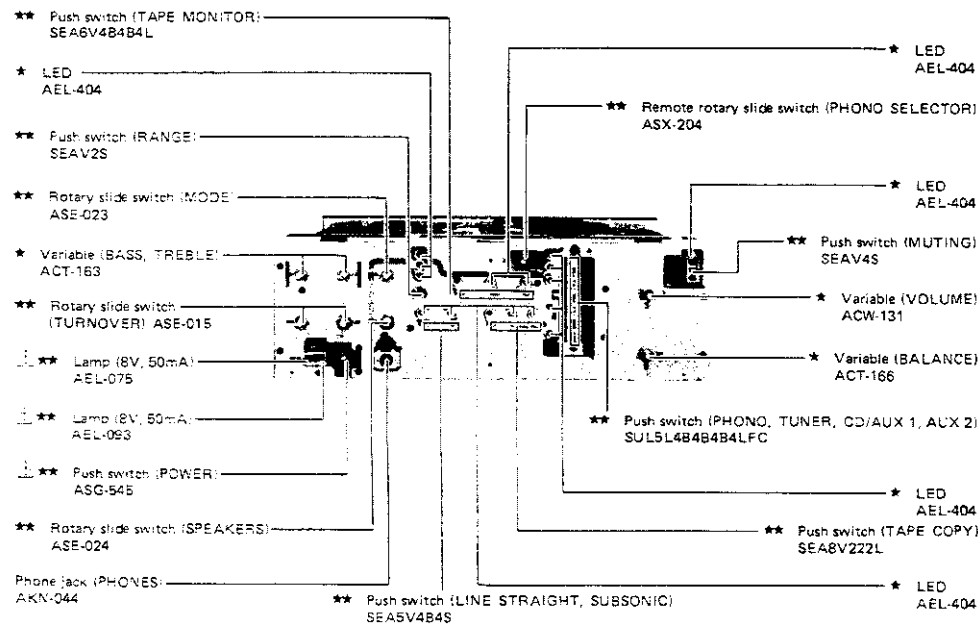

**Top View**

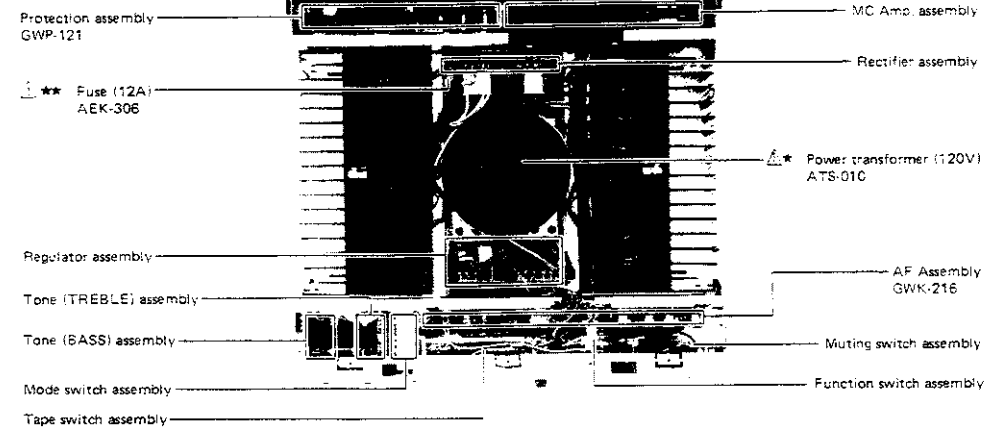

**Bottom View**

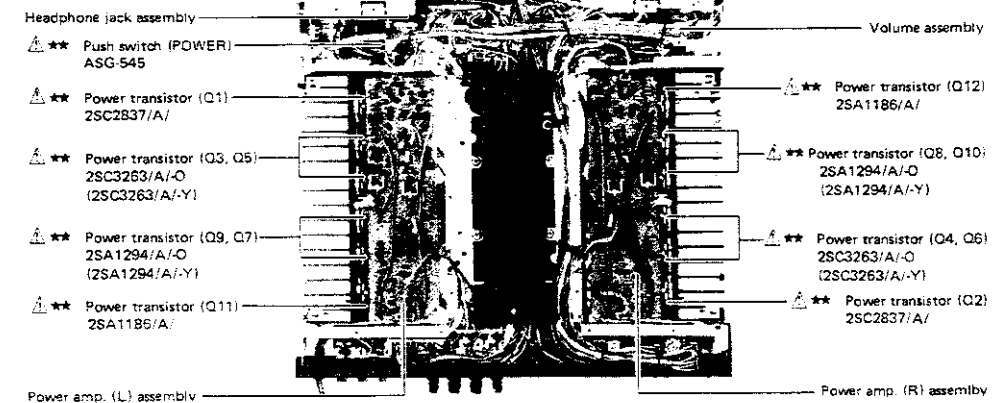

**Rear Panel**

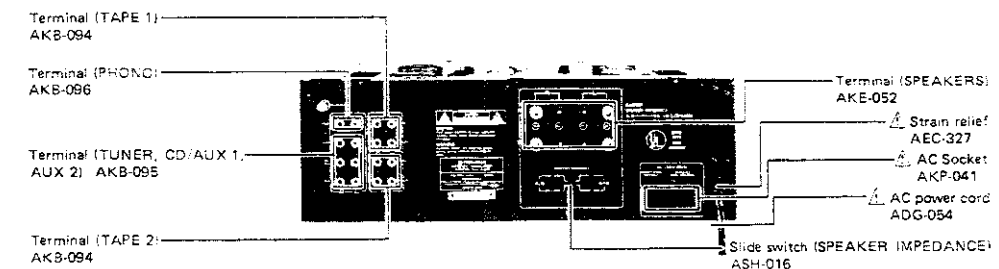



## 6. EXPLODED VIEWS AND PARTS LIST

**NOTES:**

- Parts without part number cannot be supplied.
  - The  $\Delta$  mark found on some component parts indicates the importance of the safety factor of the part. Therefore, when replacing, be sure to use parts of identical designation.
  - For your Parts Stock Control, the fast moving items are indicated with the marks \*\* and \*.
  - \*\* **GENERALLY MOVES FASTER THAN \***.
- This classification shall be adjusted by each distributor because it depends on model number, temperature, humidity, etc.

**Exterior Components**

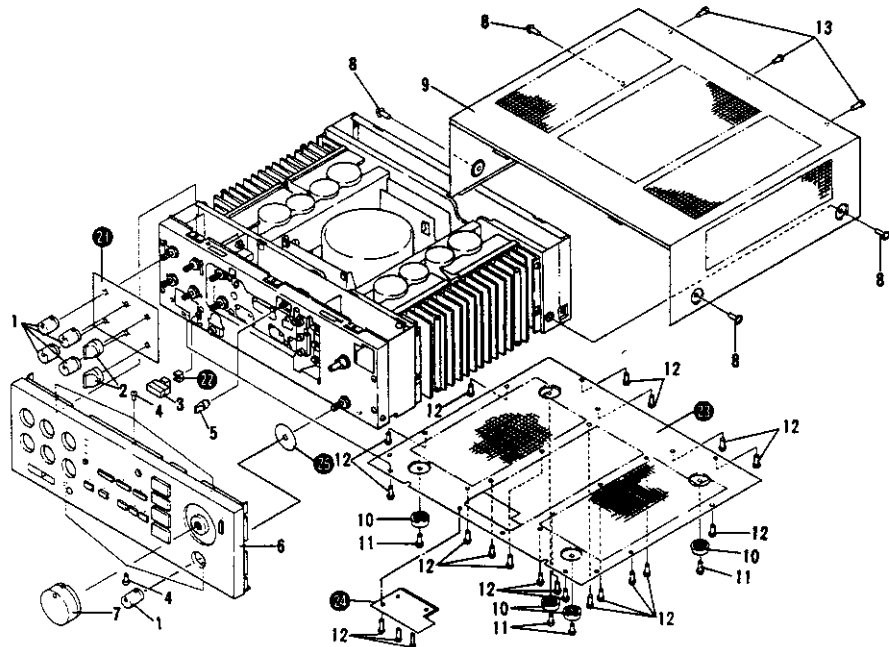

Mark	No.	Part No.	Description	Mark	No.	Part No.	Description
	1.	AAB-311	Knob B		21.		Masking sheet A
	2.	AAB-312	Knob C		22.		Flexible ring
	3.	AAD-585	Knob E		23.		Bottom plate
	4.	BBT30P080FZK	Screw (3 x 8)		24.		Sub bottom plate
	5.	AAB-313	Knob D		25.		Masking sheet
	6.	ANM-414	Front panel assembly				
	7.	AAB-310	Knob A				
	8.	FBT40P080FCR	Screw (4 x 8)				
	9.	ANE-447	Bonnet				
	10.	AEC-613	Bumper				
	11.	VTZ40P080FMC	Screw (4 x 8)				
	12.	ABA-140	Screw				
	13.	BBT30P080FZK	Screw (3 x 8)				

**Front Panel Assembly (ANM-414)**

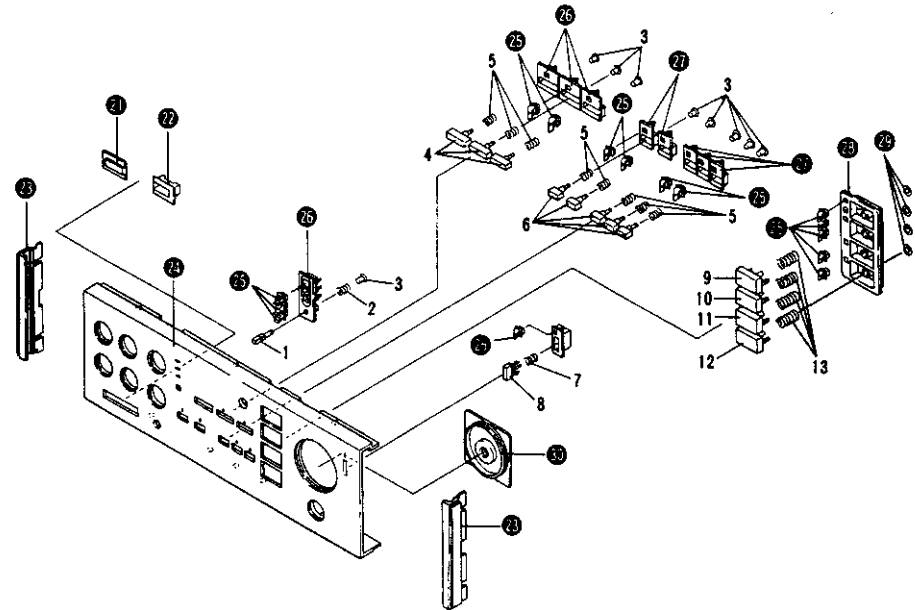

Mark	No.	Part No.	Description	Mark	No.	Part No.	Description
	1.	AAD-584	Knob D		21.		POWER indicator lens
	2.	ABH-102	Spring		22.		Spacer E
	3.	AEC-936	Stopper A		23.		Side panel
	4.	AAD-582	Knob A		24.		Front panel
	5.	ABH-099	Spring		25.		Indicator lens
	6.	AAD-583	Knob B		26.		Spacer A
	7.	ABH-091	Spring		27.		Spacer B
	8.	AAD-546	Knob C		28.		Spacer
	9.	AAD-578	Knob (PHONO)		29.		Stopper B
	10.	AAD-579	Knob (TUNER)		30.		V.L spacer
	11.	AAD-580	Knob (CD/AUX 1)				
	12.	AAD-581	Knob (AUX 2)				
	13.	ABH-100	Spring				



Mark	No.	Part No.	Description	Mark	No.	Part No.	Description
	1.	ABA-176	Screw		51.		Rubber holder
△★★	2.	AEL-075	Lamp (white lead)		52.		Lamp cap (green)
△★★	3.	AEL-093	Lamp (black lead)		53.		Lamp cap (red)
	4.	VBT30P080FZK	Screw (3 x 8)		54.		Lamp holder A
	5.	CBZ30P080FZK	Screw (3 x 8)		55.		Tone (BASS) assembly
	6.	ABN-048	Nut		56.		Tone (TREBLE) assembly
	7.	BBT30P100FZK	(Screw 3 x 10)		57.		Tape switch assembly
	8.	BMZ30P060FZK	(Screw 3 x 6)		58.		Mode switch assembly
	9.	ABN-028	Nut		59.		Power switch holder
△★	10.	ATS-010	Power transformer (120V)		60.		Headphone jack assembly
	11.	VTZ40P080FZK	Screw (4 x 8)		61.		Function switch assembly
	12.	VBZ30P100FZK	Screw (3 x 10)		62.		Muting switch assembly
	13.	BBT30P080FZK	Screw (3 x 8)		63.		Volume assembly
	14.	WS50FMC	Washer		64.		Mounting plate
	15.	BMZ50P100FMC	Screw (5 x 10)		65.		Panel stay
	16.	VBT30P080FZK	Screw (3 x 8)		66.		Transformer frame
△★★	17.	ASG-545	Push switch (POWER)		67.		Rear frame
★★	18.	ASX-204	Remote rotary switch		68.		Servo regulator assembly
	19.	AEC-384	Rivet		69.		Rear panel
	20.	GWK-216	AF assembly		70.		Shielding plate
△★★	21.	AEK-306	Fuse (12A)		71.		Grounding terminal
	22.	MTZ30P100FKZ	Screw (3 x 10)		72.		Terminal (GND)
	23.	AEC-471	Rivet		73.		Terminal (INPUT) assembly
△	24.	AKP-041	AC socket		74.		Terminal (TAPE) assembly
	25.	GWP-121	Protection assembly		75.		Cushion
	26.	ASH-016	Slide switch		76.		Shielding case
	27.	AWF-058	MC amp. assembly		77.		Front frame
	28.	B71-010	Nut		78.		Wire guide
	29.	WG70FUC	Washer		79.		Terminal
	30.	PMZ30P060SAD	Screw (3 x 6)		80.		Binder
△	31.	AEC-327	Strain relief		81.		Grounding plate
△	32.	ADG-054	AC power cord		82.		Regulator assembly
	33.	VMT30P060FZK	Screw (3 x 6)		83.		Rectifier assembly
					84.		Spacer
					85.		Heat sink assembly

Heat Sink Assembly

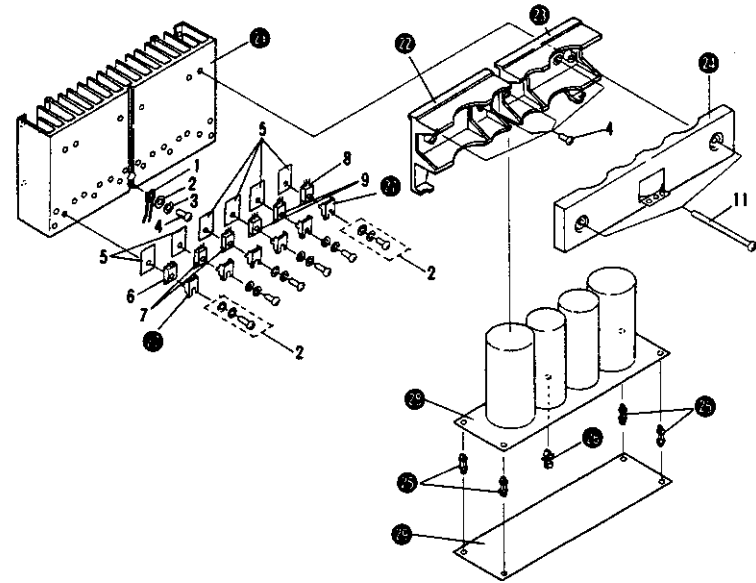

Mark	No.	Part No.	Description	No.	Part No.	Description
★	1.	STV2H	Varistor (Part of 29)	11.	PMZ40P800FZB	Screw (4 x 80)
	2.	ABA-276	Screw	21.		Heat sink
	3.	.....		22.		Capacitor holder B
	4.	VBZ30P100FZK	Screw (3 x 10)	23.		Capacitor holder A
	5.	AEC-818	Insulator	24.		Capacitor holder C
△★★	6.	2SC2837/A/	Power transistor	25.		PCB holder
△★★	7.	2SC3263/A/-O* (2SC3263/A/-Y*)	Power transistor	26.		Spacer
△★★	8.	2SA1294/A/-O* (2SA1294/A/-Y*)	Power transistor	27.		Transistor holder
△★★	9.	2SA1186/A/	Power transistor	28.		Output (L) assembly (L ch)
		*hie must have the same value.		29.		Output (R) assembly (R ch)
						Power amp. (L) assembly (L ch)
						Power amp. (R) assembly (R ch)

# 7. P.C. BOARDS CONNECTION DIAGRAM

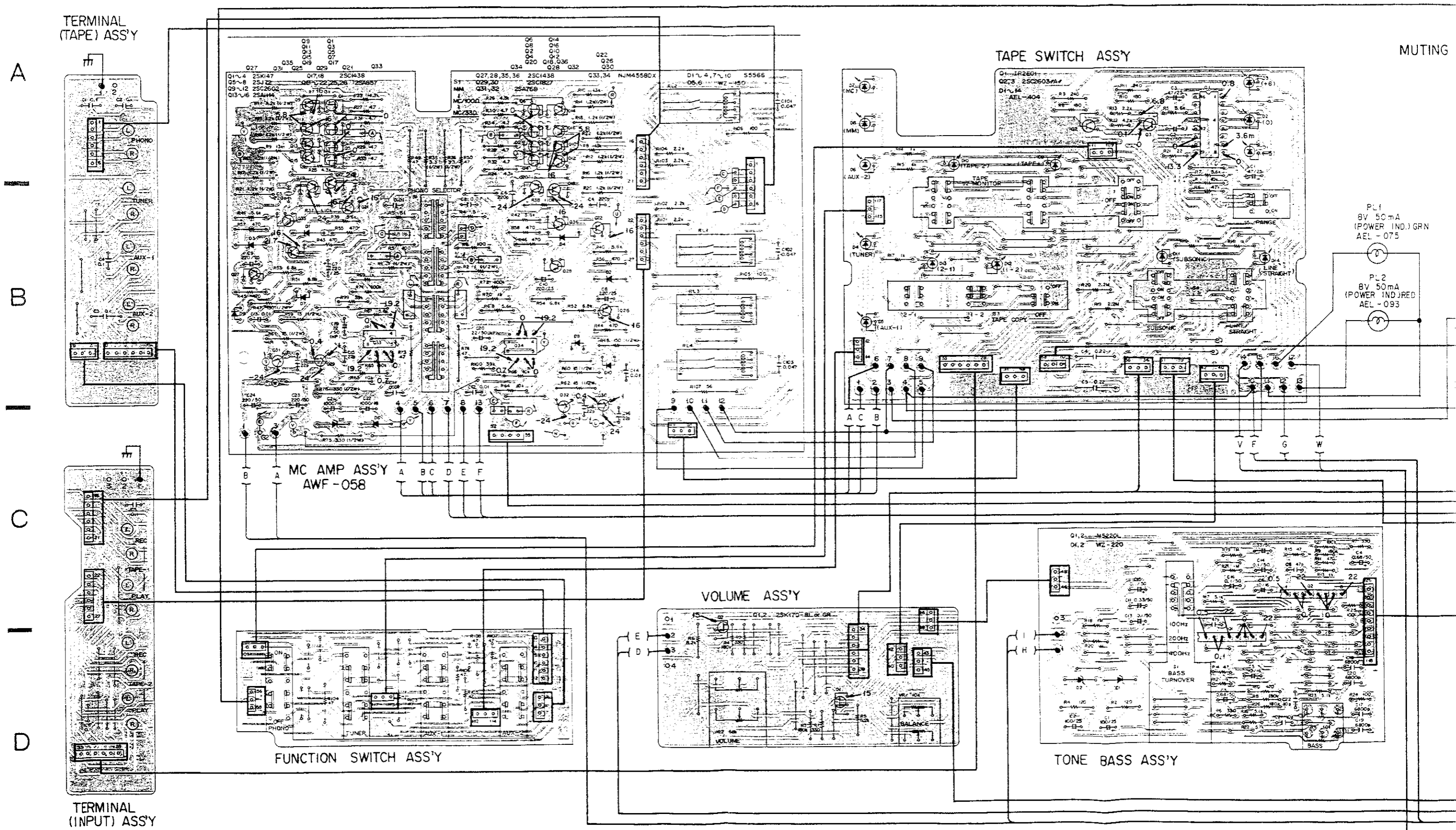



1

2

3

4

5

6

A

B

C

D

A

B

C

D

E

F

G

H

POWER (L) ASS'Y

OUTPUT (L) ASS'Y

OUTPUT (R) ASS'Y

POWER (R) ASS'Y

- Q1,2 2SC2837 FA#
- Q3~6 2SC3263#A#
- Q7~10 2SA1294#A#
- Q11,12 2SA1186#A#

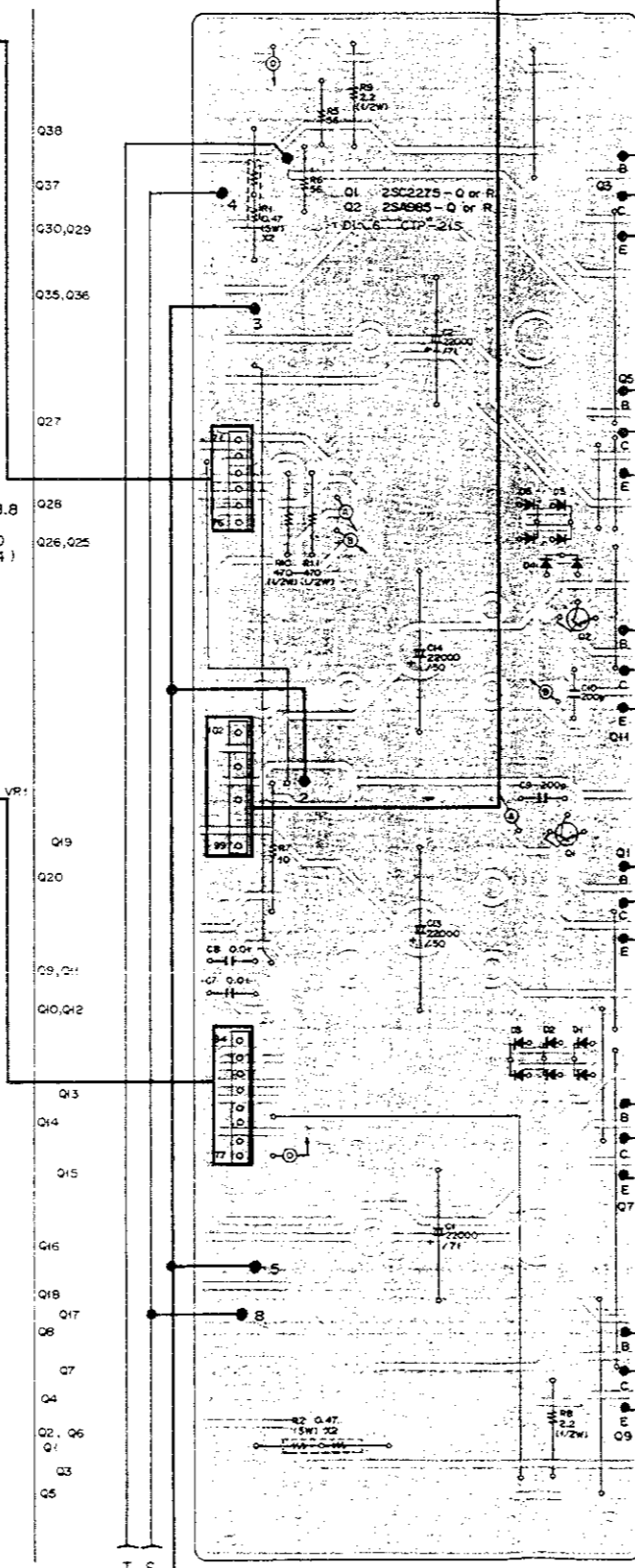
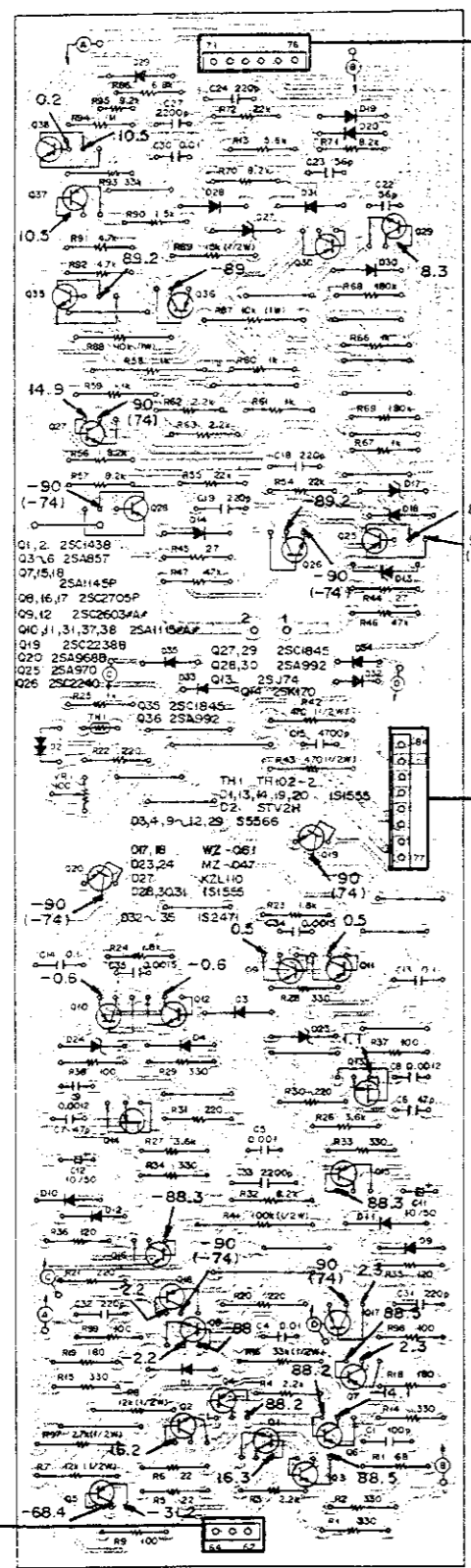

PROTECTION ASS'Y GWP -121

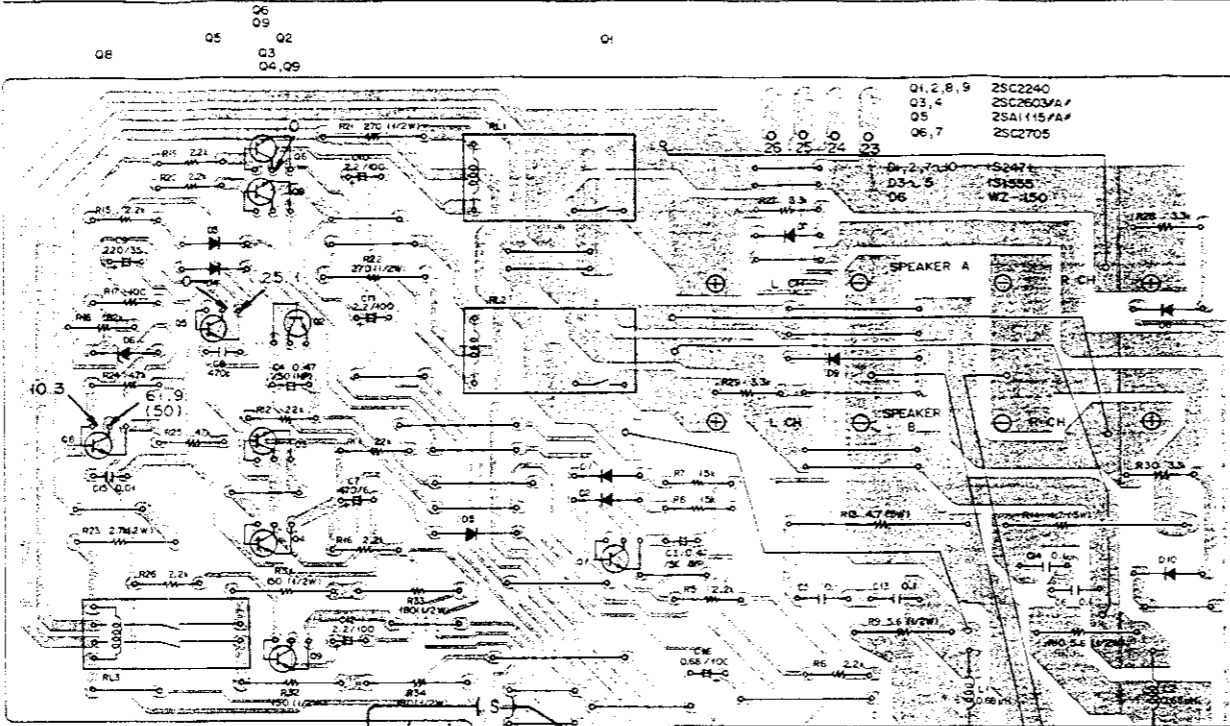

RECTIFIER ASS'Y

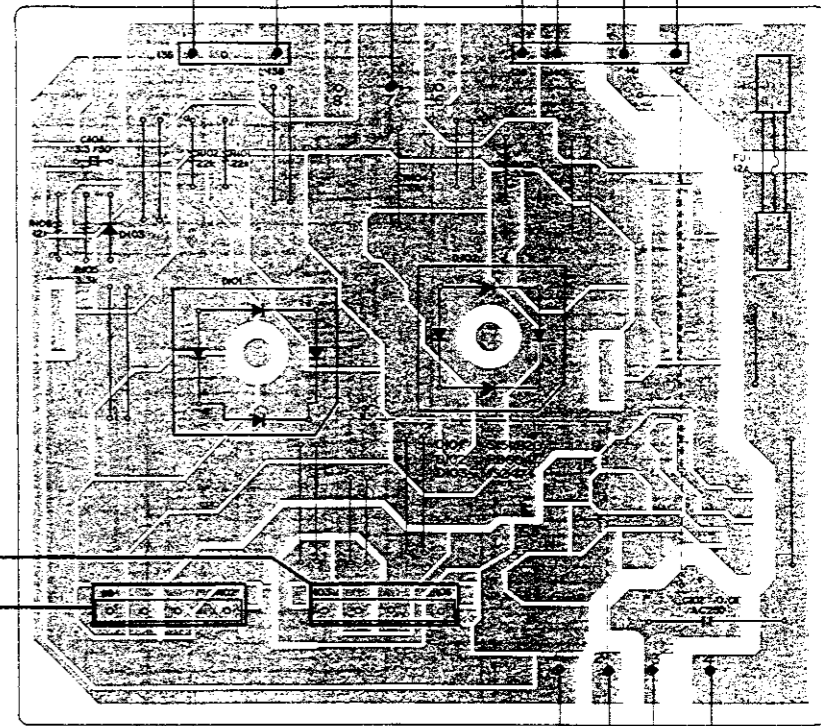

REGULATOR ASS'Y

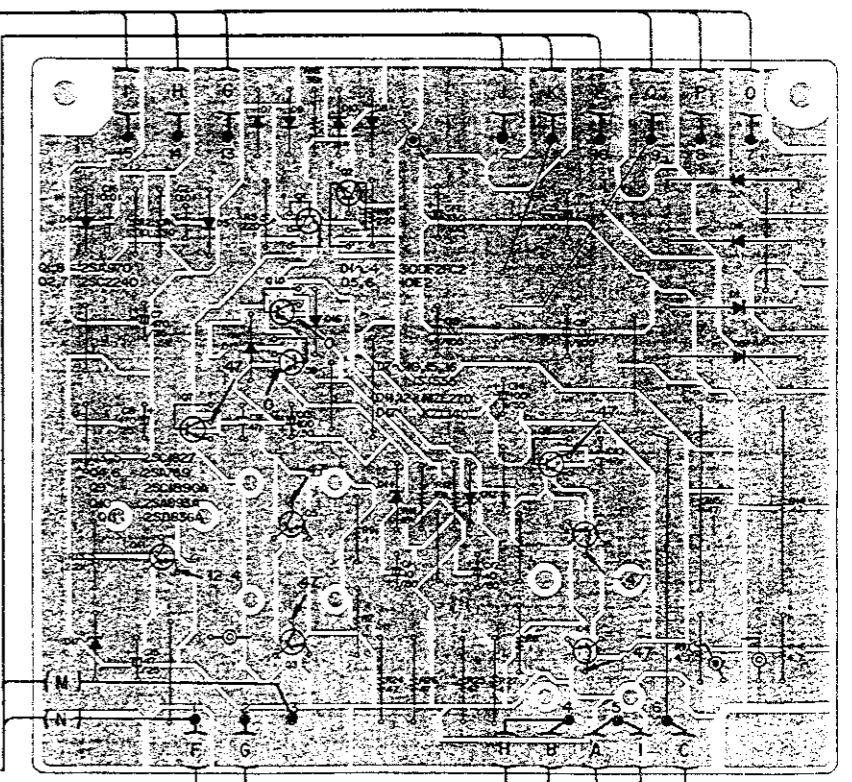

HEADPHONE JACK ASS'Y

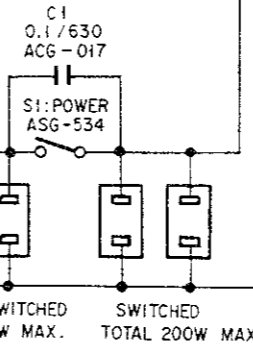
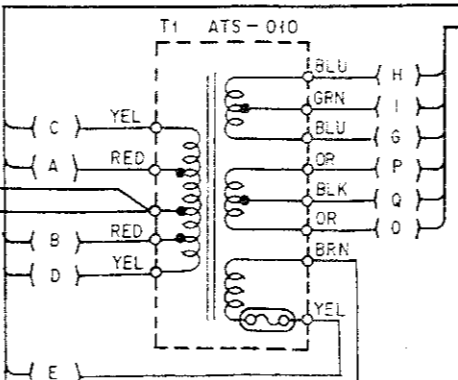
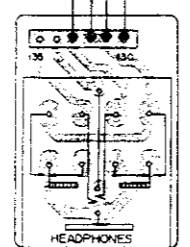

# 8. SCHEMATIC DIAGRAM

NOTE:  
The indicated semiconductors are representative ones only. Other alternative semiconductors may be used and are listed in the parts list.

A

B

C

D

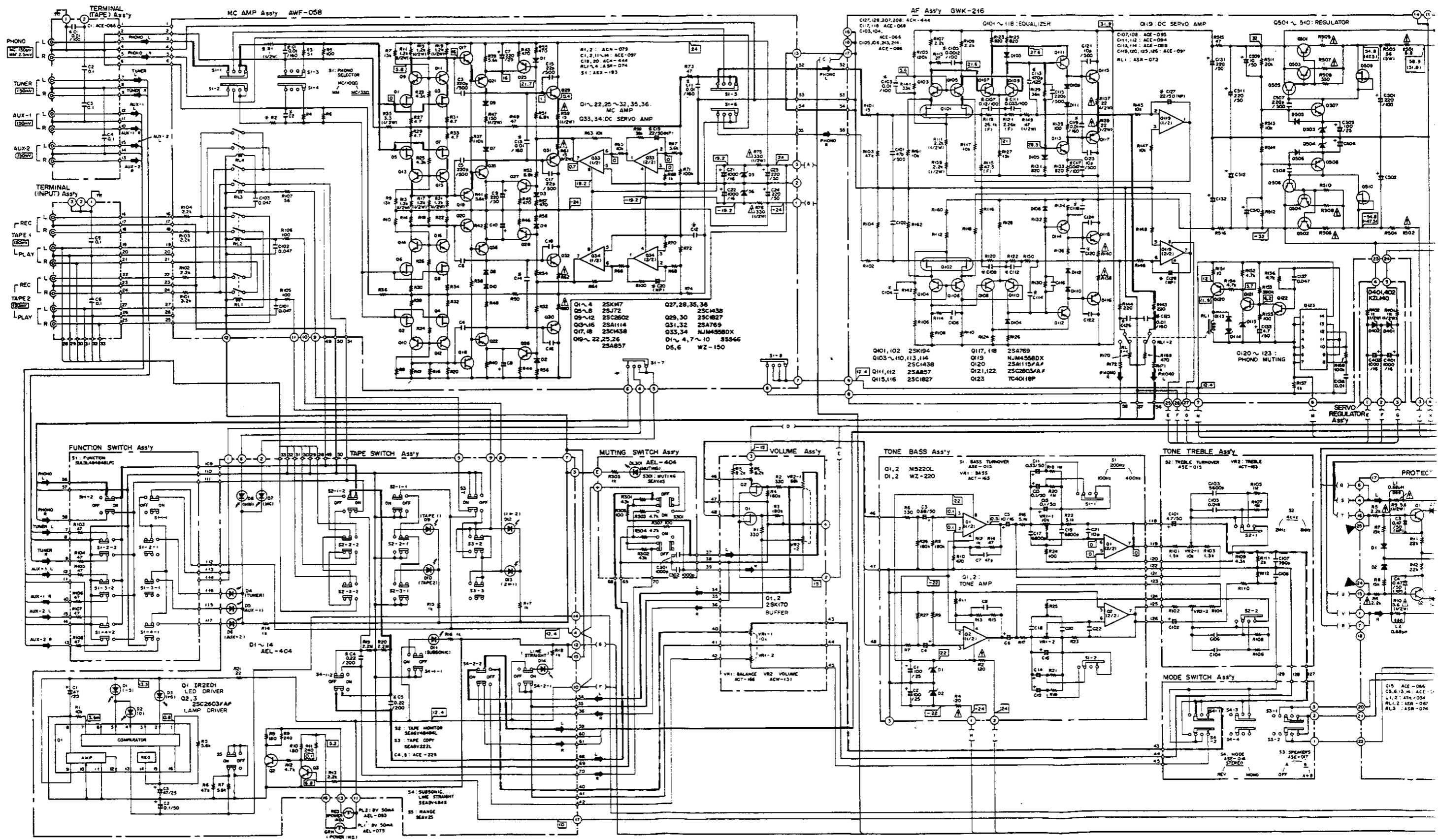



active ones  
used and

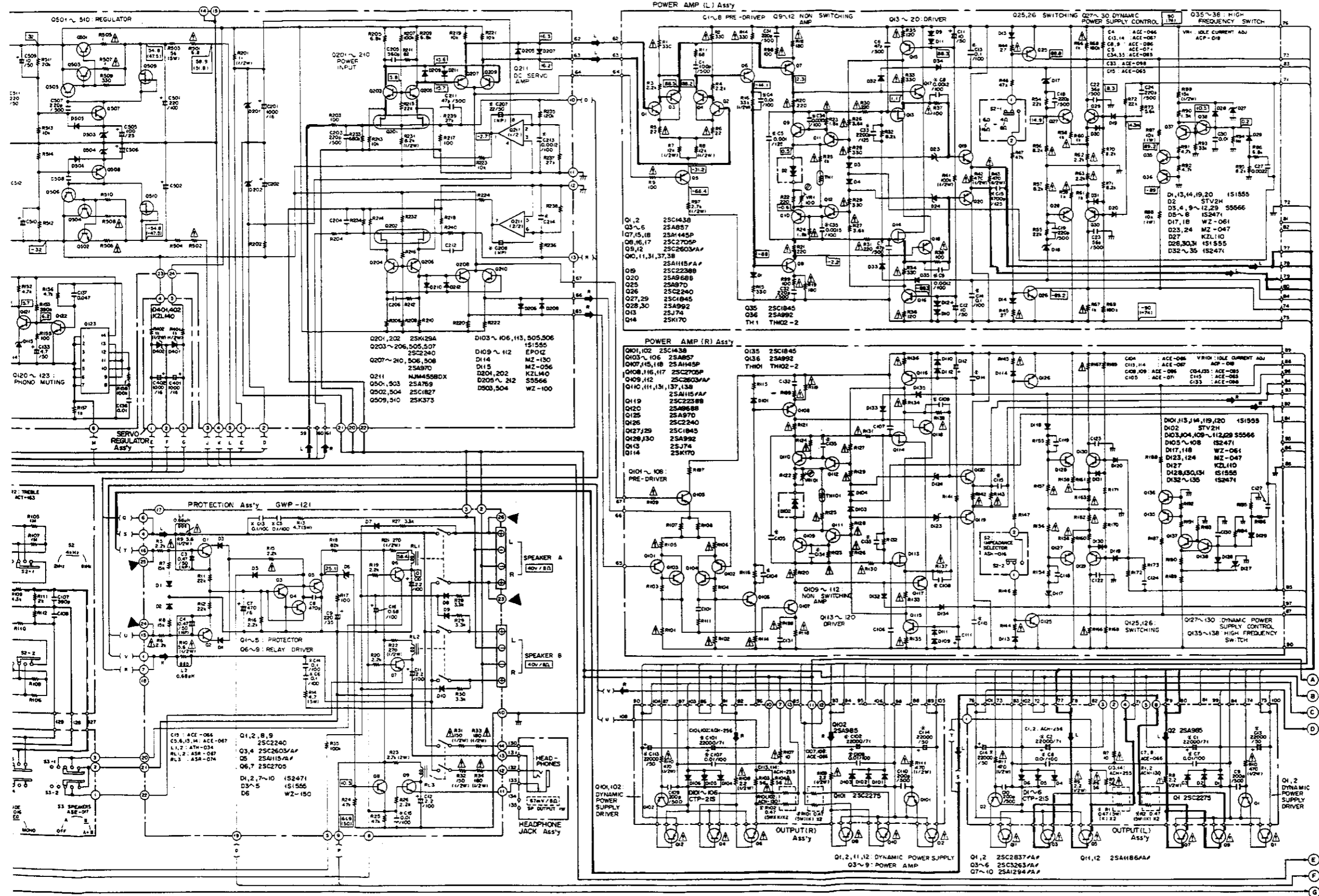

A

B

C

D

1. RESISTORS:  
Indicated in  $\Omega$ ,  $\frac{1}{2}W$ ,  $\frac{1}{4}W$ ;  $\pm 5\%$  tolerance unless otherwise noted k,  $k\Omega$ , M,  $M\Omega$ , (F);  $\pm 1\%$ , (G);  $\pm 2\%$ , (K);  $\pm 10\%$ , (M);  $\pm 20\%$  tolerance

2. CAPACITORS:  
Indicated in capacity ( $\mu F$ )/voltage (V) unless otherwise noted p,  $\mu F$ . Indication without voltage is 50V except electrolytic capacitor.

3. VOLTAGE CURRENT:  
V: Signal voltage at (200W+ 200W, 8 $\Omega$ ) output (1kHz)  
V: DC voltage (V) at no input signal  
V: DC voltage (V) at rated power.

4. OTHERS:

⊙: Signal route.  
⊙: Adjusting point.  
The  $\Delta$  mark found on some component parts indicates the importance of the safety factor of the part. Therefore, when replacing, be sure to use parts of identical designation.  
\* marked capacitors and resistors have parts numbers.

This is the basic schematic diagram, but the actual circuit may vary due to improvements in design.

SWITCHES:

OUTSIDE OF PC BOARD

S1: POWER ON - OFF  
S2: IMPEDANCE SELECTOR 4~6 $\Omega$  - 6~16 $\Omega$

MC AMP Assy  
S1: PHONO SELECTOR MC/33 $\Omega$  - MC/100 $\Omega$  - MM

FUNCTION SWITCH Assy  
S1-1: FUNCTION PHONO ON - OFF  
1-2: FUNCTION TUNER ON - OFF  
1-3: FUNCTION AUX1 ON - OFF  
1-4: FUNCTION AUX2 ON - OFF

TAPE SWITCH Assy  
S2-1: TAPE MONITOR OFF ON - OFF  
2-2: TAPE MONITOR 1 ON - OFF  
2-3: TAPE MONITOR 2 ON - OFF  
S3-1: TAPE COPY OFF ON - OFF  
3-2: TAPE COPY 1 $\rightarrow$  2 ON - OFF  
3-3: TAPE COPY 2 $\rightarrow$  2 ON - OFF  
S4-1: SUBSONIC ON - OFF  
4-2: LINE STRAIGHT ON - OFF  
S5: RANGE ON - OFF

STONE BASS Assy  
S1: BASS TURNOVER 400Hz - 200Hz - 400Hz

STONE TREBLE Assy  
S2: TREBLE TURNOVER 2kHz - 4kHz - 8kHz

MODE SWITCH Assy  
S3: SPEAKERS OFF - A - B - A+B  
S4: MODE REV - STEREO - MONO

MUTING SWITCH Assy  
S304: MUTING (-20dB) ON - OFF

The underlined indicates the switch position.

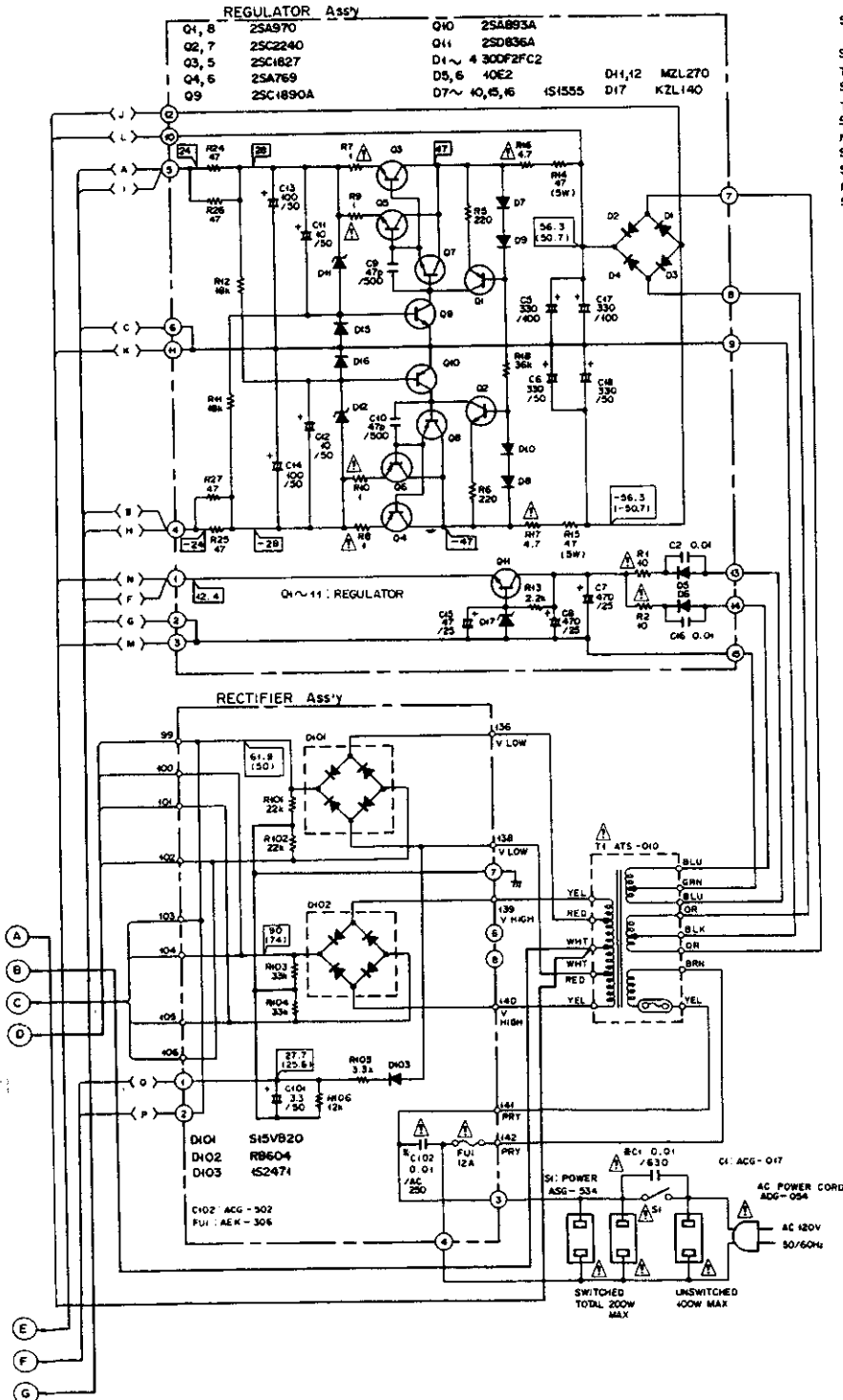

External Appearances of Transistors and IC's

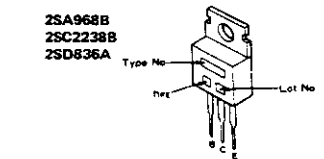
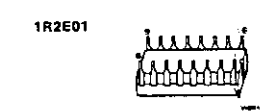
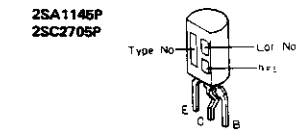
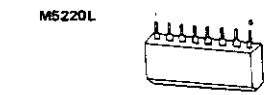
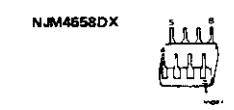
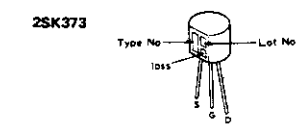
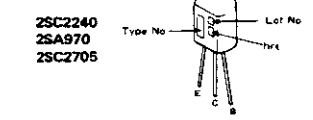
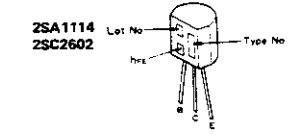
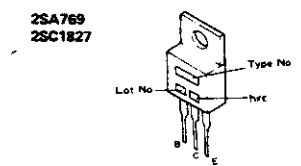
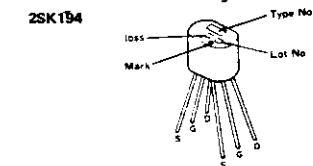
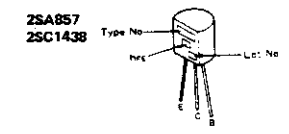
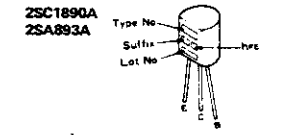
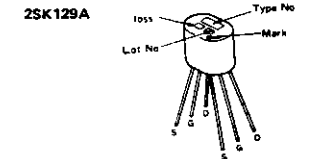
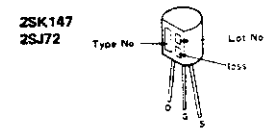
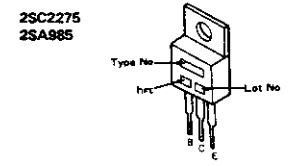
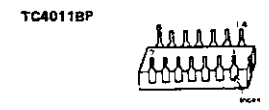
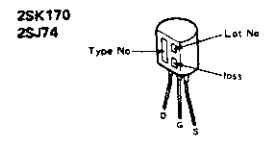
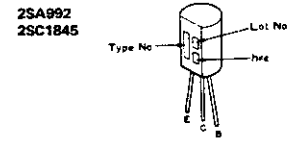
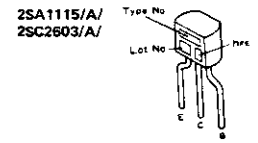
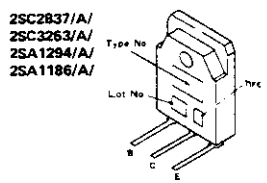

9. ELECTRICAL PARTS LIST

NOTES:

- When ordering resistors, first convert resistance values into code form as shown in the following examples.
  - Ex. 1 When there are 2 effective digits (any digit apart from 0), such as 560 ohm and 47k ohm (tolerance is shown by J = 5%, and K = 10%).
 

560Ω	56 × 10 <sup>1</sup>	561	RD4PS	J
47kΩ	47 × 10 <sup>3</sup>	473	RD4PS	J
0.5Ω	0R5		RN2H	K
1Ω	010		RS1P	K
  - Ex. 2 When there are 3 effective digits (such as in high precision metal film resistors).
 

5.62kΩ	562 × 100	5621	RN4SR	F
--------	-----------	------	-------	---
- The  $\Delta$  mark found on some component parts indicates the importance of the safety factor of the part. Therefore, when replacing, be sure to use parts of identical designation.
- For your Parts Stock Control, the fast moving items are indicated with the marks **\*\*** and **\***.
  - \*\*** GENERALLY MOVES FASTER THAN **\***.
  - This classification shall be adjusted by each distributor because it depends on model number, temperature, humidity, etc.

Miscellaneous Parts List

P.C. BOARD ASSEMBLIES

Mark	Part No.	Symbol & Description
	AWF-058	MC amp. assembly
	GWK-216	AF assembly
	GWP-121	Protection assembly
	AWH-121	Power amp. assembly
	non supply	Power amp (L) assembly
	non supply	Power amp (R) assembly
	AWR-244	Power supply assembly
	non supply	Rectifier assembly
	non supply	Regulator assembly
	AWR-243	Output assembly
	non supply	Output (L) assembly
	non supply	Output (R) assembly
	AWS-160	Switch assembly
	non supply	Tape switch assembly
	non supply	Function switch assembly
	AWG-088	Tone control assembly
	non supply	Tone (BASS) assembly
	non supply	Tone (TREBLE) assembly
	non supply	Mode switch assembly
	non supply	Headphone jack assembly
	non supply	Muting switch assembly
	non supply	Servo regulator assembly
	non supply	Terminal (TAPE) assembly
	non supply	Terminal (INPUT) assembly
	non supply	Volume assembly

SEMICONDUCTORS

Mark	Part No.	Symbol & Description
$\Delta$ **	2SC2837/A/	Q1, Q2
$\Delta$ **	2SC3263/A/-O* (2SC3263/A/-Y*)	Q3 - Q6
$\Delta$ **	2SA1294/A/-O* (2SA1294/A/-Y*)	Q7 - Q10
$\Delta$ **	2SA1186/A/	Q11, Q12

\*hfe must have the same value.

SWITCHES

Mark	Part No.	Symbol & Description
$\Delta$ **	ASG-545	S1 Push switch (POWER)
**	ASH-016	S2 Slide switch (IMPEDANCE)
**	ASX-204	Remote slide switch

OTHERS

Mark	Part No.	Symbol & Description
$\Delta$ **	AEK-306	FU1 Fuse (15A)
$\Delta$ **	AEL-075	PL1 Lamp (8V, 50mA)
$\Delta$ **	AEL-093	PL2 Lamp (8V, 50mA)
$\Delta$ *	ATS-010	T1 Power transformer (120V)
$\Delta$	ACG-017	C1 Ceramic (0.01/630V)
$\Delta$	AKP-041	AC socket
$\Delta$	ADG-054	AC power cord
$\Delta$	AEC-327	Strain relief

**Regulator Assembly  
SEMICONDUCTORS**

Mark	Part No.	Symbol & Description
**	2SA970	Q1, Q8
**	2SA769	Q4, Q6
**	2SC2240	Q2, Q7
**	2SC1827	Q3, Q5
**	2SC1890A	Q9
**	2SA893A	Q10
**	2SD836A	Q11
*	KZL140	D17
*	10E2	D5, D6
△	30DF2FC-2	D1 - D4
*	MZL 270	D11, D12
*	1S1555 (US1035)	D7 - D10, D15, D16

**CAPACITORS**

Mark	Part No.	Symbol & Description
	CEYA 100M 50	C7, C8
	CEXA 101M 50	C9, C10
	CEXA 331M 100	C1, C2, C3, C4
	CMA 470J 500	C5, C6
	CKDYB 103K 50	C11, C12
	CEA 470M 25L	C15
	CEA 471M 25L	C13, C14

**RESISTORS**

Note: When ordering resistors, convert the resistance value into code form, and then rewrite the part no. as before.

Mark	Part No.	Symbol & Description
△	RD1/4PMFL100J	R1, R2
	RTSB 470K	R14, R15
	RDH1/4P470J	R24 - R27
△	RF1/4PS4R7J	R16, R17
△	RD1/4PMF010J	R7 - R10
	RD1/4PM □□□J	Other resistors

**OTHERS**

Mark	Part No.	Symbol & Description
	VBZ30P080FZK	Screw (3 x 8)

**Power amp. (L) Assembly  
SEMICONDUCTORS**

Mark	Part No.	Symbol & Description
*	1S1555	D1, D13, D14, D19, D20, D28, D30, D31
*	S5566	D3, D4, D9 - D12, D29
*	1S2471	D32 - D35
*	MZ-047	D23, D24
*	WZ-061	D17, D18
*	STV2H	D2
*	KZL110	D27
**	2SK170	Q14
**	2SJ74	Q13
**	2SC1845	Q27, Q29, Q35
**	2SA992	Q28, Q30, Q36
**	2SA1145P	Q7, Q15, Q18
**	2SC2705P	Q8, Q16, Q18
**	2SA1115/A/	Q10, Q11, Q13, Q38
**	2SC2603/A/	Q9, Q12
**	2SC2240-BL	Q26
**	2SA970	Q25
**	2SC1438	Q1, Q2
**	2SA857	Q3 - Q6
**	2SA968B	Q20
**	2SC2238B	Q19
**	TH102-2	TH1

**CAPACITORS**

Mark	Part No.	Symbol & Description
	CEYA 100M 25	C11, C12
	ACE-066	C4 Mylar (0.01/100V)
	ACE-067	C13, C14 Mylar (0.1/100V)
	ACE-086	C8, C9 Mylar (0.0012/100V)
	ACE-071	C5 Polystyrene (1000p/125V)
	CMA 470J 500	C6, C7
	CMA 221J 500	C18, C19, C24, C31, C32
	CMA 101J 500	C1
	ACE-085	C34, C35 Mylar (0.0015/100V)
	ACE-098	C33 Polystyrene (2200p/125V)

Mark	Part No.	Symbol & Description
	ACE-066	C15 Polystyrene (4700p/125V)
	COMA 222K 50	C27
	COMA 103K 50	C30
	CCDSL 560K 500	C22, C23

**RESISTORS**

Note: When ordering resistors, convert the resistance value into code form, and then rewrite the part no. as before.

Mark	Part No.	Symbol & Description
△	ACP-019	VR1 Semi-fixed (100)
△	RF1/4PS □□□J	R9, R18 - R21, R30, R31, R33 - R38, R44, R45, R98, R99
△	RF1/2PS □□□J	R42, R43
△	RS IP 103J	R87, R88
△	RD1/4PMFL □□□J	R1, R2, R5, R6, R14, R66, R67
△	RD1/4PMF □□□J	R23 - R29, R32, R56 - R59
	RD1/2PS □□□J	R62, R63
	RD1/4PM □□□J	R7, R8, R16, R41, R89, R97
		Other resistors

**OTHERS**

Mark	Part No.	Symbol & Description
	VBZ30P080FMC	Screw (3 x 8)

**Output (R) Assembly  
SEMICONDUCTORS**

Mark	Part No.	Symbol & Description
**	2SC2275	Q101
**	2SA985	Q102
*	CTP-21S	D101 - D106

**CAPACITORS**

Mark	Part No.	Symbol & Description
	ACH-256	C101, C102 Electrolytic (22000/71V)
	ACH-255	C113, C114 Electrolytic (22000/50V)
	ACE-066	C107, C108 Mylar (0.01/100V)
	CMA 201J 500	C109, C110

**RESISTORS**

Note: When ordering resistors, convert the resistance value into code form, and then rewrite the part no. as before.

Mark	Part No.	Symbol & Description
△	ACN-130	R101, R102 Wire wound (0.47/5W x 2)
△	RF1/4PS □□□J	R105 - R107
△	RF1/2PS □□□J	R108 - R111

**OTHERS**

Mark	Part No.	Symbol & Description
	PMZ30P0608Ki	Screw (3 x 6)

**Tone (BASS) Assembly  
SEMICONDUCTORS**

Mark	Part No.	Symbol & Description
**	M5220L	Q1, Q2
*	W2-220	D1, D2

**SWITCHES**

Mark	Part No.	Symbol & Description
**	ASE-015	S1 Rotary slide switch (BASS TURNOVER)

**CAPACITORS**

Mark	Part No.	Symbol & Description
	CEA 101M 25L	C1, C2
	CEANL R68M 50	C3, C4
	CEANL 100M 16	C5, C6
	CEANL 0R1M 50	C13 - C16
	CEANL R33M 50	C11, C12
	COMA 682J 50	C17, C20
	CCDSL 100D 50	C21, C22
	CCDSL 470J 50	C7, C8

**RESISTORS**

Note: When ordering resistors, convert the resistance value into code form, and then rewrite the part no. as before.

Mark	Part No.	Symbol & Description
*	ACT-163	VR1 Volume (100k, BASS)
△	RD1/4PMFL □□□J	R2, R4
	RD1/8PM □□□J	Other resistors

**Muting Switch Assembly**

Mark	Part No.	Symbol & Description
*	AEL-404	D301 (LED Red)
**	SEAV4S	S301 Push switch (MUTING)
	QOSA 102J 50	C301, C302
	RD1/4PM □□□J	R301 - R307

**Mode Switch Assembly**

Mark	Part No.	Symbol & Description
**	ASE-024	S3 Rotary slide switch (SPEAKERS)
**	ASE-023	S4 Rotary slide switch (MODE)

**Headphone Jack Assembly**

Mark	Part No.	Symbol & Description
	AKN-044	Phone jack (PHONES)

## Function Switch Assembly

Mark	Part No.	Symbol & Description
**	SUL5L4B4B4LFC RD1/8PM470J	Push switch (FUNCTION) R103 - R108

## Terminal (INPUT) Assembly

Mark	Part No.	Symbol & Description
	ACE-066 CQMLA 104K 50	C1 Mylar (0.01/100V) C2 - C4
	AKB-096 AKB-095	Terminal (PHONO) Terminal (TUNER, AUX)

## Tone (TREBLE) Assembly

## SWITCHES

Mark	Part No.	Symbol & Description
**	ASE-015	S2 Rotary slide switch (TREBLE TURNOVER)

## CAPACITORS

Mark	Part No.	Symbol & Description
	CEANL 4R7M 50 CQMA 562J 50 CQMA 183J 50 CKDYB 391K 50	C101, C102 C103, C104 C105, C106 C107, C108

## RESISTORS

Note: When ordering resistors, convert the resistance value into code form, and then rewrite the part no. as before.

Mark	Part No.	Symbol & Description
*	ACT-163 RD1/8PM 000J	VR2 Volume (10k, TREBLE) R101 - R112

## Volume Assembly

Mark	Part No.	Symbol & Description
**	25K170	Q1, Q2
*	ACT-166	VR1 Volume (10k, BALANCE)
*	ACW-131 RD1/4PM 000J	VR2 Volume (68k, VOLUME) R1 - R6

## Terminal (TAPE) Assembly

Mark	Part No.	Symbol & Description
	CQMLA 104K 50 AKB-094	C5, C6 Terminal (TAPE)

## Protection Assembly (GWP-121)

## SEMICONDUCTORS

Mark	Part No.	Symbol & Description
**	25C2240	Q1, Q2, Q8, Q9
**	25C2705	Q6, Q7

Mark	Part No.	Symbol & Description
**	25C2603/A/	Q3, Q4
**	2SA1115/A/	Q5
*	1S2471	D1, D2, D7 - D10
*	1S1555 (1S2076)	D3 - D5
*	WZ-150	D6

## CAPACITORS

Mark	Part No.	Symbol & Description
	ACE-066 ACE-067	C15 Mylar (0.01/100V) C5, C6, C13, C14 (0.1/100V)
	CEANP R47M 50 CEA 2R2M 100L CEA 471M 6L	C3, C4 C10 - C12 C7
	CEA 221M 35L CEA R68M 100L CKDYB 471K 50	C9 C16 C8

## RESISTORS

Note: When ordering resistors, convert the resistance value into code form, and then rewrite the part no. as before.

Mark	Part No.	Symbol & Description
△	RD1/2PSF5R6J RS2P272J RTS84R7K	R9, R10 R23 R13, R14
△	RD1/2PSF151F	R31 - R34
△	RD1/4PMF222J	R5, R6, R15
	RD1/2PS271J RD1/4PM 000J	R21, R22 Other resistors

## OTHERS

Mark	Part No.	Symbol & Description
**	ASR-067	RL1, RL2 Relay
**	ASR-074	RL3 Relay
	ATH-034	L1, L2 AF choke coil
	AKE-052 VBZ30P080FZK PM230P060SAD	Terminal (SPEAKERS) Screw (3 x 8) Screw (3 x 6)

## Rectifier Assembly

## SEMICONDUCTORS

Mark	Part No.	Symbol & Description
△ *	S15V820	D101
△ *	R8604	D102
*	1S2471	D103

## CAPACITORS

Mark	Part No.	Symbol & Description
△	CEA 3R3M 50L ACG-502	C101 C102 Ceramic (0.01/AC 125V)

## RESISTORS

Note: When ordering resistors, convert the resistance value into code form, and then rewrite the part no. as before.

Mark	Part No.	Symbol & Description
	RD1/4PM 000J	R101 - R106

## OTHERS

Mark	Part No.	Symbol & Description
	VBZ30P200FZK	Screw (3 x 20)

## Output (L) Assembly

## SEMICONDUCTORS

Mark	Part No.	Symbol & Description
**	25C2275	Q1
**	2SA985	Q2
*	CTP-21S	D1 - D6

## CAPACITORS

Mark	Part No.	Symbol & Description
	ACH-256	C1, C2 Electrolytic (22000/71V)
	ACH-255	C13, C14 Electrolytic (22000/50V)
	ACE-066 CMA 201J 500	C7, C8 Mylar (0.01/100V) C9, C10

## RESISTORS

Note: When ordering resistors, convert the resistance value into code form, and then rewrite the part no. as before.

Mark	Part No.	Symbol & Description
	ACN-130	R1, R2 Wire wound (0.47/5W x 2)
△	RF1/4PS 000J	R5 - R7
△	RF1/2PS 000J	R8 - R11

## OTHERS

Mark	Part No.	Symbol & Description
	PM230P0608Ki	Screw (3 x 6)

## MC amp. Assembly (AWF-058)

## SEMICONDUCTORS

Mark	Part No.	Symbol & Description
**	25K147-V1	Q1 - Q4
**	25J72-V2	Q5 - Q8
**	2SA857	Q19 - Q22, Q25, Q26
**	2SA769	Q31, Q32
**	2SA1114	Q13 - Q16

Mark	Part No.	Symbol & Description
**	25C1438	Q17, Q18, Q27, Q28, Q35, Q36
**	25C1827	Q29, Q30
**	25C2602	Q9 - Q12
**	NJM4558DX	Q33, Q34
*	S5566	D1 - D4, D7 - D10
*	WZ-150	D5, D6

## CAPACITORS

Mark	Part No.	Symbol & Description
	ACE-097	C1, C2, C11 - C14 Polystyrene (0.01/160V)
	ACH-444	C19, C20 Electrolytic (2.2/50V, NP)
	CEXA 102M 16 CEYA 221M 25 CEXA 221M 50	C21, C22 C7 - C10 C23, C24
	CKDYF 473Z 50 CMA 220J 500 CMA 221J 500	C101, C103 C15 - C18 C3 - C6

## RESISTORS

Note: When ordering resistors, convert the resistance value into code form, and then rewrite the part no. as before.

Mark	Part No.	Symbol & Description
△	ACN-079 RDH1/4P 000J RD1/2PSF 000J RD1/2PS 000J RD1/4PM 000J	R1, R2 Carbon (1/1/2W) R49, R50, R73, R74 R59 - R62, R75, R76 R11 - R22, R35, R36, R47, R48 Other resistors

## OTHERS

Mark	Part No.	Symbol & Description
**	ASR-074	RL1 - RL4 Relay
**	ASX-193	S1 Remote slide switch (PHONO SELECTOR)
	VBZ30P080FZK	Screw (3 x 8)

## Tape Switch Assembly

## SEMICONDUCTORS

Mark	Part No.	Symbol & Description
**	IR2E01	Q1
**	25C2603/A/	Q2, Q3
*	AEL-404	D1 - D4 (LED Red)

## SWITCHES

Mark	Part No.	Symbol & Description
**	SEA6V4B4B4L	S2 Push switch (TAPE MONITOR)
**	SEA8V222L	S3 Push switch (TAPE COPY)

Mark	Part No.	Symbol & Description
**	SEA5V4B4S	S4 Push switch (LINE STRAIGHT, SUBSONIC)
**	SEAV2S	SS Push switch (RANGE)

## CAPACITORS

Mark	Part No.	Symbol & Description
	CEA 470M 25L	C1, C3
	CEA 0R1M 50L	C2
	ACE-225	C4, C5 Metallized mylar (0.22/200V)

## RESISTORS

Note: When ordering resistors, convert the resistance value into code form, and then rewrite the part no. as before.

Mark	Part No.	Symbol & Description
	RD1/4PM □□□J	R8 - R11, R14 - R20
	RD1/8PM □□□J	Other resistors

## OTHERS

Mark	Part No.	Symbol & Description
	VMZ30P060FMC	Screw (3 x 6)

## Power amp. (R) Assembly

## SEMICONDUCTORS

Mark	Part No.	Symbol & Description
*	1S1555	D101, D113, D114, D119, D120, D128, D130, D131
*	S5566	D103, D104, D109 - D112, D129
*	1S2471	D132 - D135
*	MZ-047	D123, D124
*	WZ-061	D117, D118
*	STV2H	D102
*	KZL110	D127
**	2SK170-BL	Q114
**	2SJ74-BL	Q113
**	2SC1845	Q127, Q129, Q135
**	2SA992	Q128, Q130, Q136
**	2SA1145P	Q107, Q115, Q118
**	2SC2705P	Q108, Q116, Q117
**	2SA1115/A/	Q110, Q111, Q137, Q138
**	2SC2603/A/	Q109, Q112
**	2SC2240	Q126
**	2SA970	Q125

Mark	Part No.	Symbol & Description
**	2SC1438	Q101, Q102
**	2SA857	Q103 - Q106
**	2SA9688	Q120
**	2SC22388	Q119
**	TH102-2	TH101

## CAPACITORS

Mark	Part No.	Symbol & Description
	CEYA 100M 25	C111, C112
	ACE-066	C104 Mylar (0.01/100V)
	ACE-067	C113, C114 Mylar (0.1/100V)
	ACE-086	C108, C109 Mylar (0.0012/100V)
	ACE-071	C105 Polystyrene (1000p/125V)
	CMA 470J 500	C106, C107
	CMA 221J 500	C118, C119, C124, C131, C132
	CMA 101J 500	C101
	ACE-085	C134, C135 Mylar (0.0015/100V)
	ACE-098	C133 Polystyrene (2200p/125V)
	ACE-065	C115 Polystyrene (4700p/125V)
	QOMA 222K 50	C127
	QOMA 103K 50	C130
	CCDSL 560K 500	C122, C123

## RESISTORS

Note: When ordering resistors, convert the resistance value into code form, and then rewrite the part no. as before.

Mark	Part No.	Symbol & Description
	ACP-019	VR101 Semi-fixed (100)
△	RF1/4PS □□□J	R109, R118 - R121, R130, R131, R133 - R138, R144, R145, R198, R199
△	RF1/2PS □□□J	R142, R143
△	RS1P103J	R187, R188
△	RD1/4PMFL □□□J	R101, R102, R105, R106, R114, R166, R167
△	RD1/4PMF □□□J	R123 - R129, R132, R156 - R159, R162, R163
	RD1/2PS □□□J	R107, R108, R126, R141, R189, R197
	RD1/4PM □□□J	Other resistors

## OTHERS

Mark	Part No.	Symbol & Description
	VBZ30P080FMC	Screw (3 x 8)

## AF Assembly (GWK-216)

## SEMICONDUCTORS

Mark	Part No.	Symbol & Description
**	TC40118P	Q123
**	NJM4558DX	Q119, Q211
**	2SC2240	Q203 - Q206, Q505, Q507
**	2SC1438	Q103 - Q110, Q113, Q114, Q121, Q122
**	2SC2603/A/	
**	2SC1827	Q115, Q116, Q502, Q504
**	2SA970	Q207 - Q210, Q506, Q508
**	2SA1115/A/	Q120
**	2SA857	Q111, Q112
**	2SK129A	Q201, Q202
**	2SK194	Q101, Q102
**	2SA769	Q117, Q118, Q501, Q503
**	2SK373-Y	Q509, Q510
*	1S1555	D103 - D106, D113, D505, D506
*	S5566	D205 - D212
*	MZ-056	D115
*	MZ-130	D114
*	EP01Z	D109 - D112
*	WZ-100	D503, D504
*	KZL140	D201, D202

## CAPACITORS

Mark	Part No.	Symbol & Description
	ACH-444	C127, C128, C207, C208 Electrolytic (22/50V, NP)
	CEYA 100M 50	C509, C510
	CEYA 101M 25	C505, C506
	CEAYA 102M 16	C201, C202
	CEXA 221M 50	C131, C132, C511, C512
	CEXA 221M 100	C501, C502
	ACE-068	C117, C118 Mylar (0.047/100V)
	ACE-066	C103, C104 Mylar (0.01/100V)
	ACE-086	C105, C106, C213, C214 Mylar (0.0012/100V)
	ACE-095	C107, C108 Polypropylene (0.12/100V)
	ACE-094	C111, C112 Polypropylene (0.033/100V)

Mark	Part No.	Symbol & Description
	ACE-097	C119, C120, C125, C126 Polystyrene (0.01/160V)
	ACE-071	C129, C130 Polystyrene (0.001/125V)
	ACE-089	C113, C114 Polystyrene (470p/125V)
	CMA 221J 500	C115, C116, C203, C204, C507, C508
	CMA 470J 500	C101, C102, C211, C212
	CMA 100D 500	C121 - C124
	CEANL 4R7M 50	C133
	QOSH 561J 50	C205, C206
	CKDYF 103Z 50	C136
	CKDYF 473Z 50	C137

## RESISTORS

Note: When ordering resistors, convert the resistance value into code form, and then rewrite the part no. as before.

Mark	Part No.	Symbol & Description
	RDH1/4P □□□□F	R115, R116, R119 - R122
	RDH1/4P □□□J	R101, R102, R143, R144, R149, R150, R203, R204, R217, R218, R171, R172, R515, R516
	RT58 560K	R503, R504
△	RF1/4PM6R8J	R501, R502
△	RD1/2PSF 220J	R137 - R140
	RD1/2PS □□□J	R111, R112, R159, R160, R201, R202, R231, R232
△	RD1/4PMF 010J	R505, R508
	RD1/4PM □□□J	Other resistors

## OTHERS

Mark	Part No.	Symbol & Description
**	ASR-072	RL1 Relay

## Servo Regulator Assembly

## SEMICONDUCTORS

Mark	Part No.	Symbol & Description
*	KZL140	D401, D402

## CAPACITORS

Mark	Part No.	Symbol & Description
	CEYA 102M 16	C401, C402

## RESISTORS

Note: When ordering resistors, convert the resistance value into code form, and then rewrite the part no. as before.

Mark	Part No.	Symbol & Description
	RD1/2PS102J	R401, R402

## 10. ADJUSTMENTS

### Idle Current Adjustment

1. Turn the VOLUME control down to minimum volume, and switch the LINE STRAIGHT switch on.
2. Rotate VR1 and VR101 counter clockwise.
3. Switch the power on with no input and no load applied to the unit.
4. Adjust VR1 to obtain a reading of 25mV ~ 30mV between TP25 ( + ) and TP26 ( - ). (L ch)
5. Adjust VR101 to obtain a reading of 25mV ~ 30mV between TP24 ( + ) and TP23 ( - ). (R ch)
6. Readjust after aging for at least 30 minutes.

### Reference:

Center DC output voltage tolerance:  $0V \pm 50mV$ .

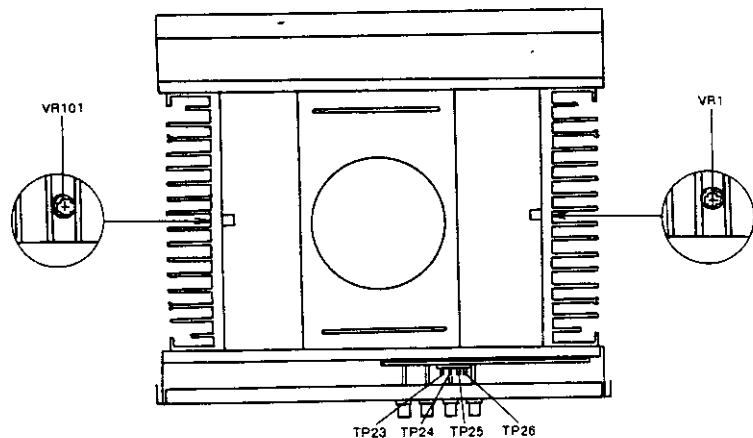

## 11. SAFETY INFORMATION

### 1. SAFETY PRECAUTIONS

The following check should be performed for the continued protection of the customer and service technician.

#### LEAKAGE CURRENT CHECK

Measure leakage current to a known earth ground (water pipe, conduit, etc.) by connecting a leakage current tester such as Simpson Model 229-2 or equivalent between the earth ground and all exposed metal parts of the appliance (input/output terminals, screwheads, metal overlays, control shaft, etc.). Plug the AC line cord of the appliance directly into a 120V AC 60Hz outlet and turn the AC power switch on. Any current measured must not exceed 0.5mA.

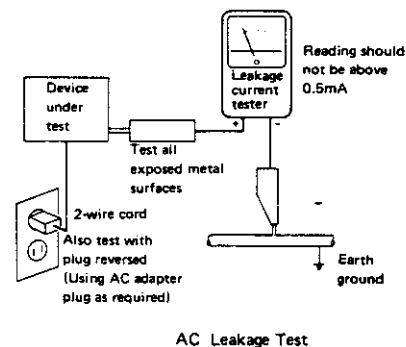

ANY MEASUREMENTS NOT WITHIN THE LIMITS OUTLINED ABOVE ARE INDICATIVE OF A POTENTIAL SHOCK HAZARD AND MUST BE CORRECTED BEFORE RETURNING THE APPLIANCE TO THE CUSTOMER.

### 2. PRODUCT SAFETY NOTICE

Many electrical and mechanical parts in the appliance have special safety related characteristics. These are often not evident from visual inspection nor the protection afforded by them necessarily can be obtained by using replacement components rated for voltage, wattage, etc. Replacement parts which have these special safety characteristics are identified in this Service Manual.

Electrical components having such features are identified by marking with a  $\Delta$  on the schematics and on the parts list in this Service Manual.

The use of a substitute replacement component which does not have the same safety characteristics as the PIONEER recommended replacement one, shown in the parts list in this Service Manual, may create shock, fire, or other hazards.

Product Safety is continuously under review and new instructions are issued from time to time. For the latest information, always consult the current PIONEER Service Manual. A subscription to, or additional copies of, PIONEER Service Manual may be obtained at a nominal charge from PIONEER.

## 12. PACKING

### PACKING

Mark	No.	Part No.	Description
	1.	AHA-328	Side pad L
	2.	ARB-561	Operating instructions (English)
	3.	AHA-329	Side pad R
	4.	AHC-067	Wrapping case
	5.	AHE-205	Packing case

