

Service Manual

PIONEER
The Art of Entertainment

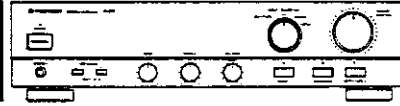

ORDER NO.
ARP2508

STEREO AMPLIFIER

A-201

A-101

A-201, A-101 HAVE THE FOLLOWING:

Type	Model		Power Requirement	Remarks
	A-201	A-101		
HEWZ	○	—	AC220-230V, 240V (switchable) *	
HE	○	—	AC220-230V, 240V (switchable) *	
HB	○	—	AC220-230V, 240V (switchable) *	
YPW	—	○	AC240V only	
SD	○	○	AC110V, 120-127V, 220V, 240V (switchable)	

* Change the connection of the power transformer's primary wiring.

- This manual is applicable to A-201/HEWZ, HE, HB, SD, A-101/YPW and SD types.
- For A-201/HE, HB, SD and A-101/SD types, refer to pages 28-30.

CONTENTS

1. EXPLODED VIEWS AND PARTS LIST	2
2. PACKING AND PARTS LIST	5
3. SCHEMATIC AND PCB CONNECTIONS DIAGRAMS	6
4. PCB PARTS LIST	24
5. FOR A-201/HE, HB AND SD TYPES	28
6. FOR A-101/SD TYPE	29
7. SPECIFICATIONS	31
8. PANEL FACILITIES	32

PIONEER ELECTRONIC CORPORATION 4-1, Meguro 1-Chome, Meguro-ku, Tokyo 153, Japan
PIONEER ELECTRONICS SERVICE INC. P.O. Box 1760, Long Beach, California 90801 U.S.A.
PIONEER ELECTRONICS OF CANADA, INC. 300 Allstate Parkway Markham, Ontario L3R 0P2 Canada
PIONEER ELECTRONIC [EUROPE] N.V. Haven 1087 Keetberglaan 1, 9120 Melsele, Belgium
PIONEER ELECTRONICS AUSTRALIA PTY. LTD. 178-184 Boundary Road, Braeside, Victoria 3195, Australia TEL: [03] 580-9911
© PIONEER ELECTRONIC CORPORATION 1992

SG APR. 1992 Printed in Japan

1. EXPLODED VIEWS AND PARTS LIST

NOTES:

- Parts marked by "NSP" are generally unavailable because they are not in our Master Spare Parts List.
- The Δ mark found on some component parts indicates the importance of the safety factor of the part. Therefore, when replacing, be sure to use parts of identical designation.
- Parts marked by "⊙" are not always kept in stock. Their delivery time may be longer than usual or they may be unavailable.

Parts List of A-201

Mark	No.	Description	Part No.
⊙	1	AF assembly	AWZ2356
⊙	2	Front assembly	AWZ2360
Δ	3	Power transformer (T1)	ATS1338
	4	Remote slide rotary switch (S1)	ASU1023
Δ	5	Fuse (FU1, T1.25A/250V)	AEK - 509
Δ	6	AC Power cord	ADG1049
	7	Insulator assembly	AMR2140
	8	
	9	
	10	Coil spring (B)	ABH - 052
	11	Coil spring (B)	ABH1034
	12	Strain relife	AEC - 882
	13	Screw	ABA - 298
	14	Screw	ABA1007
	15	Screw	ABA1009
	16	Screw	ABA1048
	17	Nut	ABN - 065
	18	Nut	NK70FUC
	19	Nut	NK90FZB
	20	Screw	VMZ30P060FCU
	21	Screw	VPZ30P100FMC
	22	Front panel	ANB1522
	23	Panel base	AMB1630
	24	Friction plate	AAM1029
	25	LED lens	AMR1160
	26	Knob (S)	AAB1155
	27	Knob (L)	AAB1097
	28	Knob (M)	AAB1098
	29	Knob (B)	AAD - 418
	30	Knob (POWER)	AAD1984
	31	Knob	AAD1536
	32	Bonnet	ANE1174
	33	Screw	ABA1022
	34	Rivet	AEC1035
	35	Screw	ABA1011
NSP	101	LED assembly	AWZ2363
NSP	102	Power SW assembly	AWZ2362
NSP	103	SP SW assembly	AWZ2364
	104	
NSP	105	Terminal (GND)	AKE - 031
NSP	106	Chassis	ANA1086
NSP	107	Rear panel	ANC1365
NSP	108	Bottom plate	ANF1047
NSP	109	Shield plate	ANK1113
NSP	110	Binder	AEC - 093
NSP	111	Name sticker	AAL1947
NSP	112	Heat sink	ANH1192

Parts List of A-101

Mark	No.	Description	Part No.
⊙	1	AF assembly	AWZ2359
⊙	2	Front assembly	AWZ2361
Δ	3	Power transformer (T1)	ATS1339
	4	Remote slide rotary switch (S1)	ASU1023
Δ	5	Fuse (FU1, T800mA/250V)	AEK - 507
Δ	6	AC Power cord	ADG1050
	7	
	8	
	9	Leg assembly	AEC - 784
	10	Coil spring (B)	ABH - 052
	11	Coil spring (B)	ABH1034
	12	Strain relife	AEC - 882
	13	Screw	ABA - 298
	14	Screw	ABA1007
	15	Screw	ABA1009
	16	Screw	ABA1048
	17	Nut	ABN - 065
	18	Nut	NK70FUC
	19	Nut	NK90FZB
	20	
	21	Screw	VPZ30P100FMC
	22	Front panel	ANB1523
	23	Panel base	AMB1630
	24	Friction plate	AAM1029
	25	LED lens	AMR1160
	26	Knob (S)	AAB1155
	27	Knob (L)	AAB1097
	28	Knob (M)	AAB1098
	29	
	30	Knob (POWER)	AAD1984
	31	Knob	AAD1536
	32	Bonnet	ANE1173
	33	Screw	ABA1022
	34	Rivet	AEC1035
	35	Screw	ABA1011
NSP	101	LED assembly	AWZ2363
NSP	102	Power SW assembly	AWZ2362
	103	
NSP	104	Headphone assembly	AWZ2367
NSP	105	Terminal (GND)	AKE - 031
NSP	106	Chassis	ANA1086
NSP	107	Rear panel	ANC1363
NSP	108	Bottom plate	ANF1047
	109	
NSP	110	Binder	AEC - 093
NSP	111	Name sticker	AAL1952
NSP	112	Heat sink	ANH1191

2. PACKING AND PARTS LIST

NOTES:

- A • Parts marked by "NSP" are generally unavailable because they are not in our Master Spare Parts List.
- The Δ mark found on some component parts indicates the importance of the safety factor of the part. Therefore, when replacing, be sure to use parts of identical designation.
- Parts marked by "⊙" are not always kept in stock. Their delivery time may be longer than usual or they may be unavailable.

Parts List of A-201

Parts List of A-101

Mark	No.	Description	Part No.	Mark	No.	Description	Part No.
	1	Front - rear pad	AHA1240		1	Front - rear pad	AHA1240
	2	Packing case	AHD2271		2	Packing case	AHD2272
	3	Operating instructions (German)	ARC1354		3	Operating instructions (English)	ARB1372
	4	Sheet	AHG1017		4	Sheet	AHG1017

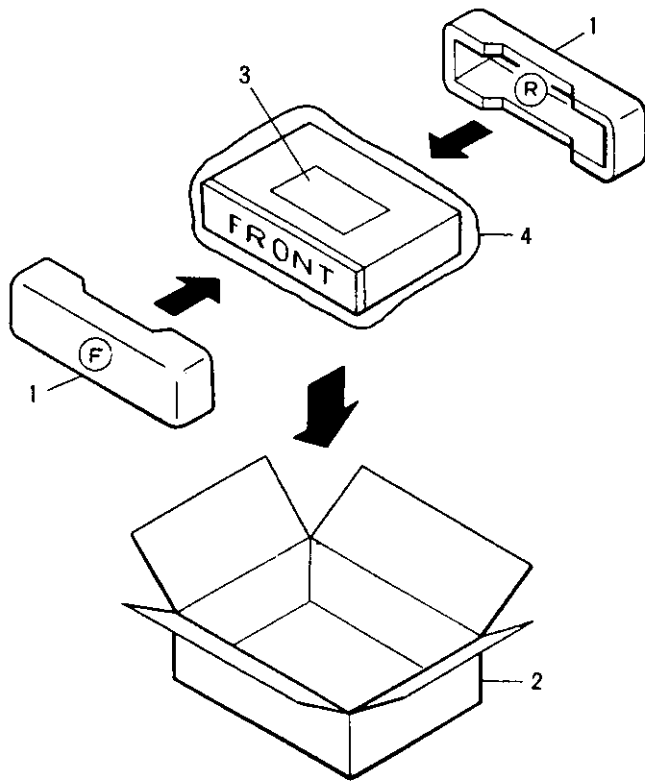

Exterior

A

B

C

D

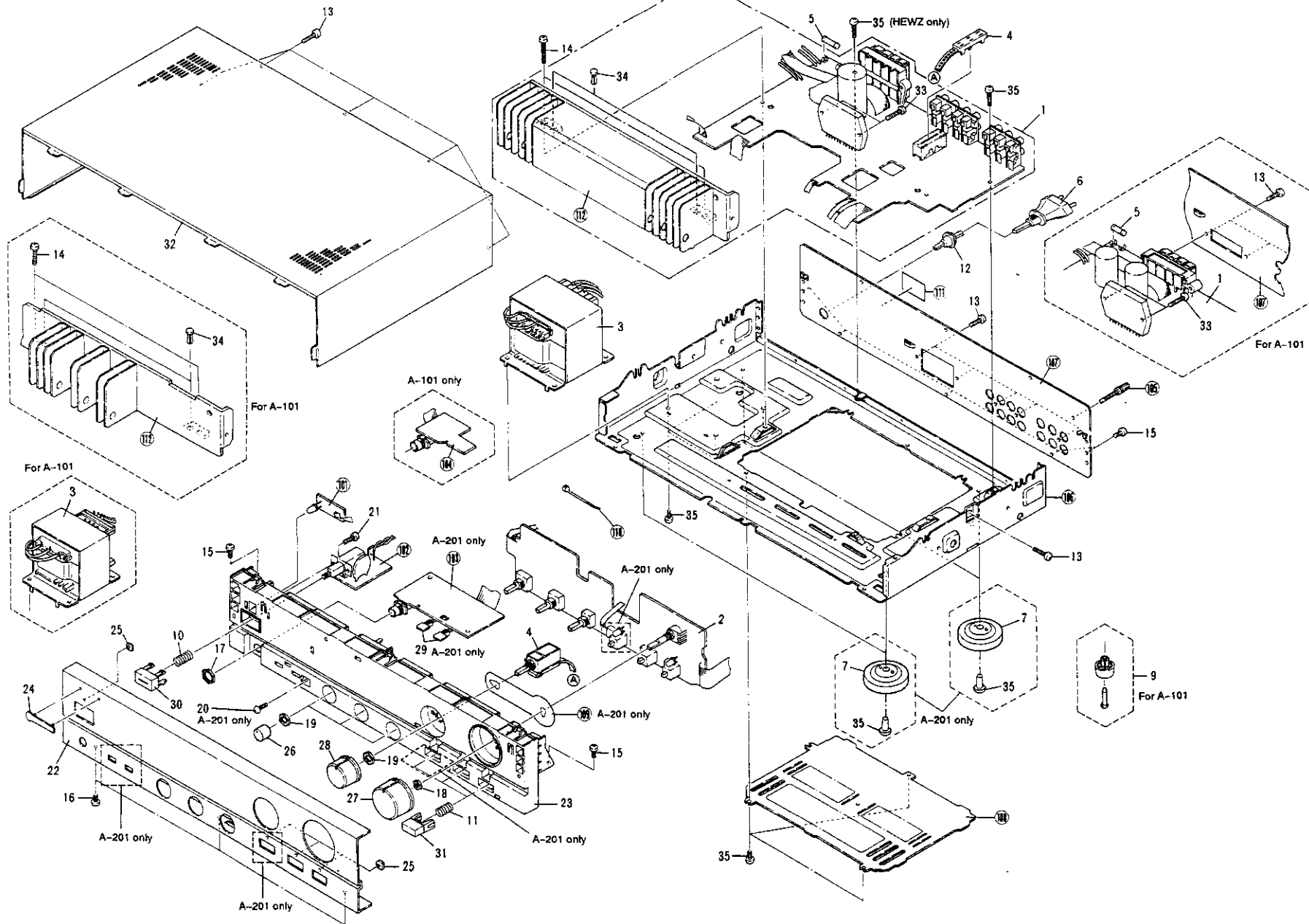

2. f

NOTES:

- Parts m
- The Δ to use p
- Parts m

Parts l

Mark l

A

B

C

D

3. SCHEMATIC AND PCB CONNECTIONS DIAGRAMS

3.1 SCHEMATIC DIAGRAM OF A-201

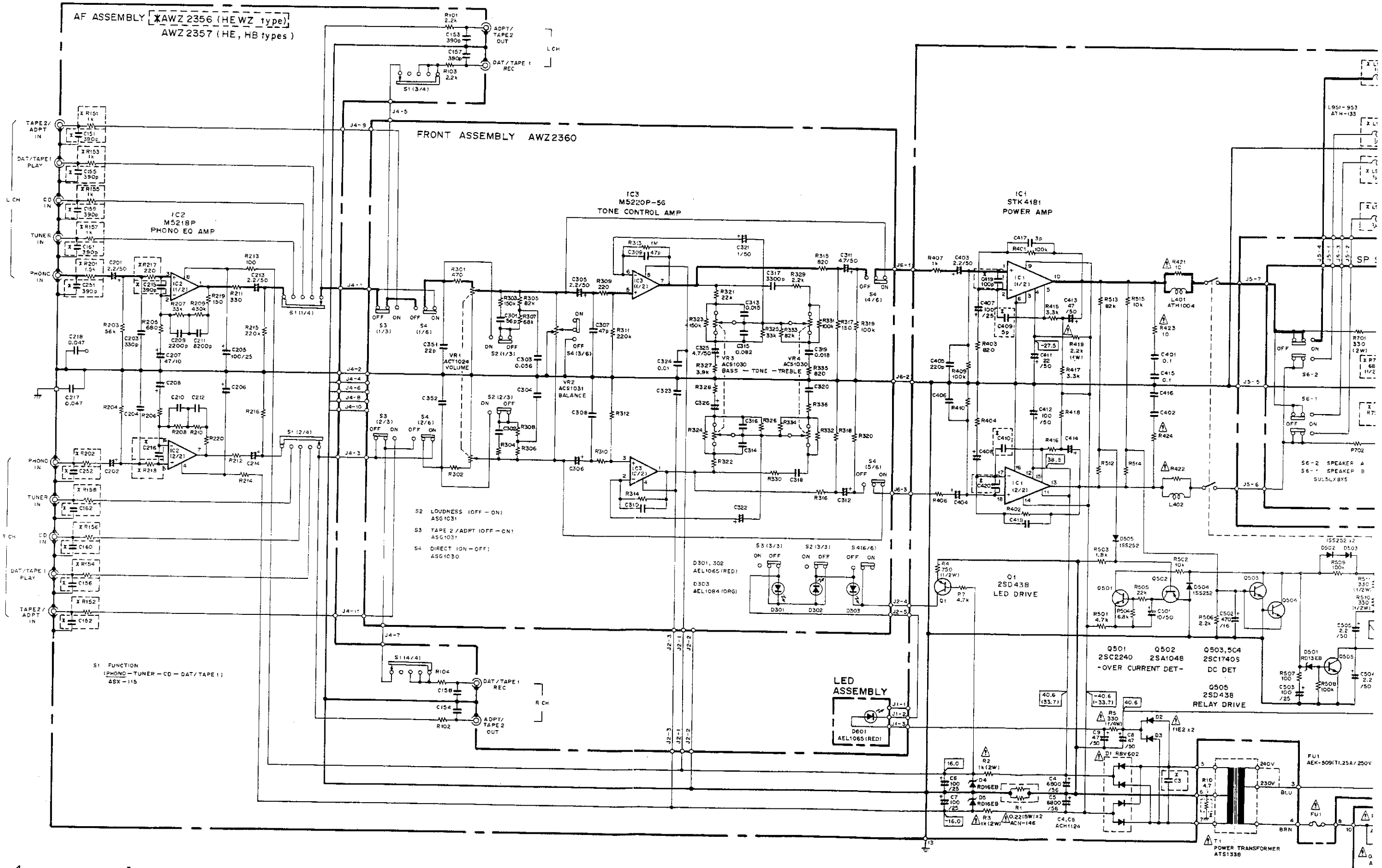

GRAMS

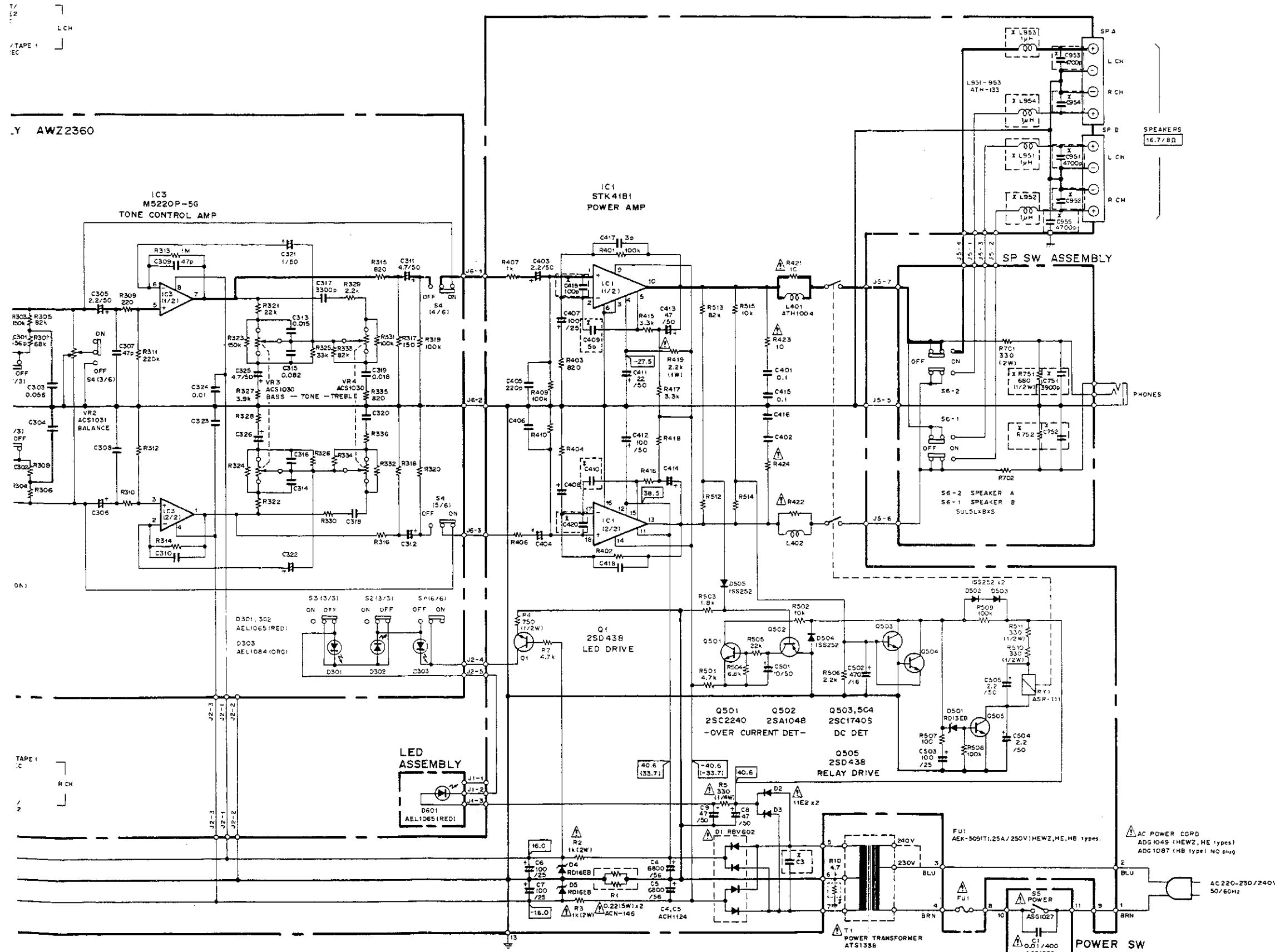

- This circuit diagram is based on the HEWZ version.
- Parts with an asterisk (*) are different from this prepared for the HE and HB versions.
- Refer to the comparison list.

* Marks are difference between two assemblies.		
	HEWZ model	HE, HB models
AF Assembly	AWZ2356	AWZ2357
R151-R158	1k Ω	VACANT (JAMPER WIRE)
R201, R202	1.5k Ω	330 Ω
R217, R218	220 Ω	180 Ω
C151, C152, C155, C156, C159-C162, C251, C252	390p	VACANT (OPEN)
C951-C955	4700p	VACANT (OPEN)
C215, C216	390p	220p
C419, C420	100p	150p
C3	0.1 μ	0.01 μ (ACG1005)
C409, C410	5p	2p
L951-L954	ATM-133 (1 μ H)	VACANT (JAMPER WIRE)
SP SW Assembly		
R751, R752	680 Ω (1/2W)	VACANT (OPEN)
C751, C752	3900p	VACANT (OPEN)

- RESISTORS:** Indicated in Ω, 2W, 1/2W, 1/8W, ±5% tolerance unless otherwise noted; k: kΩ, M: MΩ, (F): ±1%, (G): ±2%, (K): ±10%, (M): ±20% tolerance.
- CAPACITORS:** Indicated in capacity (μF)/voltage (V) unless otherwise noted; p: pF. Indication without voltage is 50V except electrolytic capacitor.
- VOLTAGE CURRENT:**
 - Signal voltage at (35W + 35W, 8Ω) output (1kHz)
 - DC voltage (V) at no input signal
 - Value in () is DC voltage at rated power.
- OTHERS:**
 - Signal route
 - Adjusting point
- SWITCHES (Underline indicates switch position)**
 - S1: FUNCTION (PHONO-TUNER-CD-DAT/TAPE1)
 - S2: LOUDNESS (ON-OFF)
 - S3: ADPT/TAPE2 (ON-OFF)
 - S4: DIRECT (ON-OFF)
 - S5: POWER (ON-OFF)
 - S6-1: SPEAKERS B (ON-OFF)
 - S6-2: SPEAKERS A (ON-OFF)

This is the basic schematic diagram, but the actual circuit may vary due to improvements in design.

Line Voltage Selection (HEWZ, HE and HB types)

- Line voltage can be changed with following steps.
1. Disconnect the AC power cord.
 2. Remove the Bonnet case.
 3. Change the connection of the power transformer lead wire.
 4. Stick the line voltage label on the rear panel.

Part No.	Description	
AAX-193	220v label	—— 220V
AAX-192	240v label	----- 240V

3.2 PCB CONNECTIONS DIAGRAM OF A-201

- View from component side

NOTE

1. This PCB wiring diagram is derived from the parts list.
2. The parts which have been assembled on the board can be replaced with their stock parts by the corresponding wiring symbols in the following Table.

PCB symbols (with no. in circle)	Corresponding parts (with no.)	Part Name
(1504)		Resistor
(1505)		Resistor (High Temperature)
(2203)		Capacitor
(1507)		Resistor
(151)		Capacitor (Electrolytic)
(1518)		Capacitor (Electrolytic)

PCB symbols (with no. in circle)	Part Name
(15)	36 150
(16)	36 1
(17)	36 1
(18)	36 100 10 10

1. The parts which are marked with a circle are to be replaced with their stock parts.
2. The parts which are marked with a square are to be replaced with their stock parts.
3. The parts which are marked with a triangle are to be replaced with their stock parts.

FRONT ASSEMBLY AWZ2360

AF ASSEMBLY
 * AWZ2356 (HE, WZ type)
 AWZ2357 (HE, HB types)

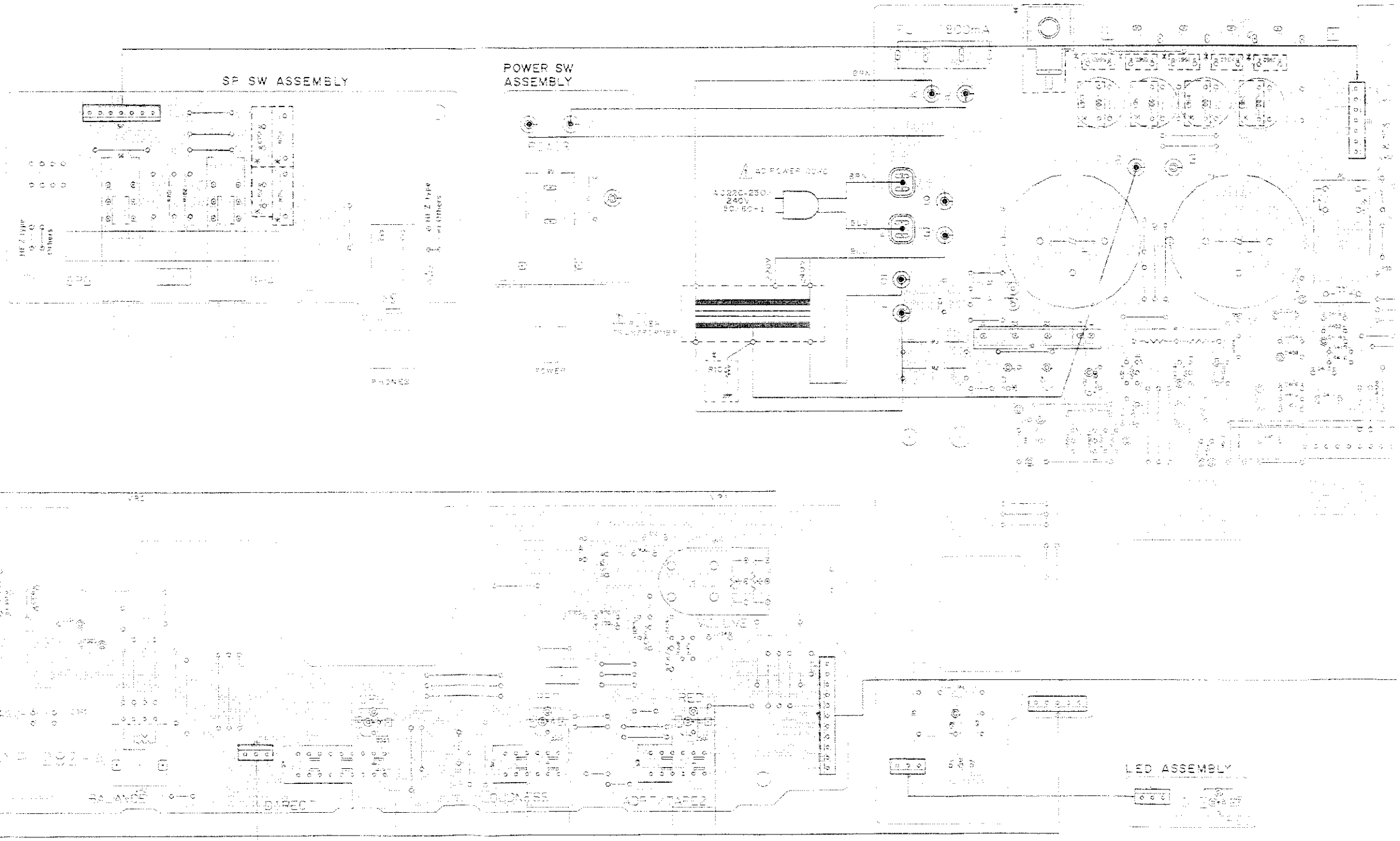

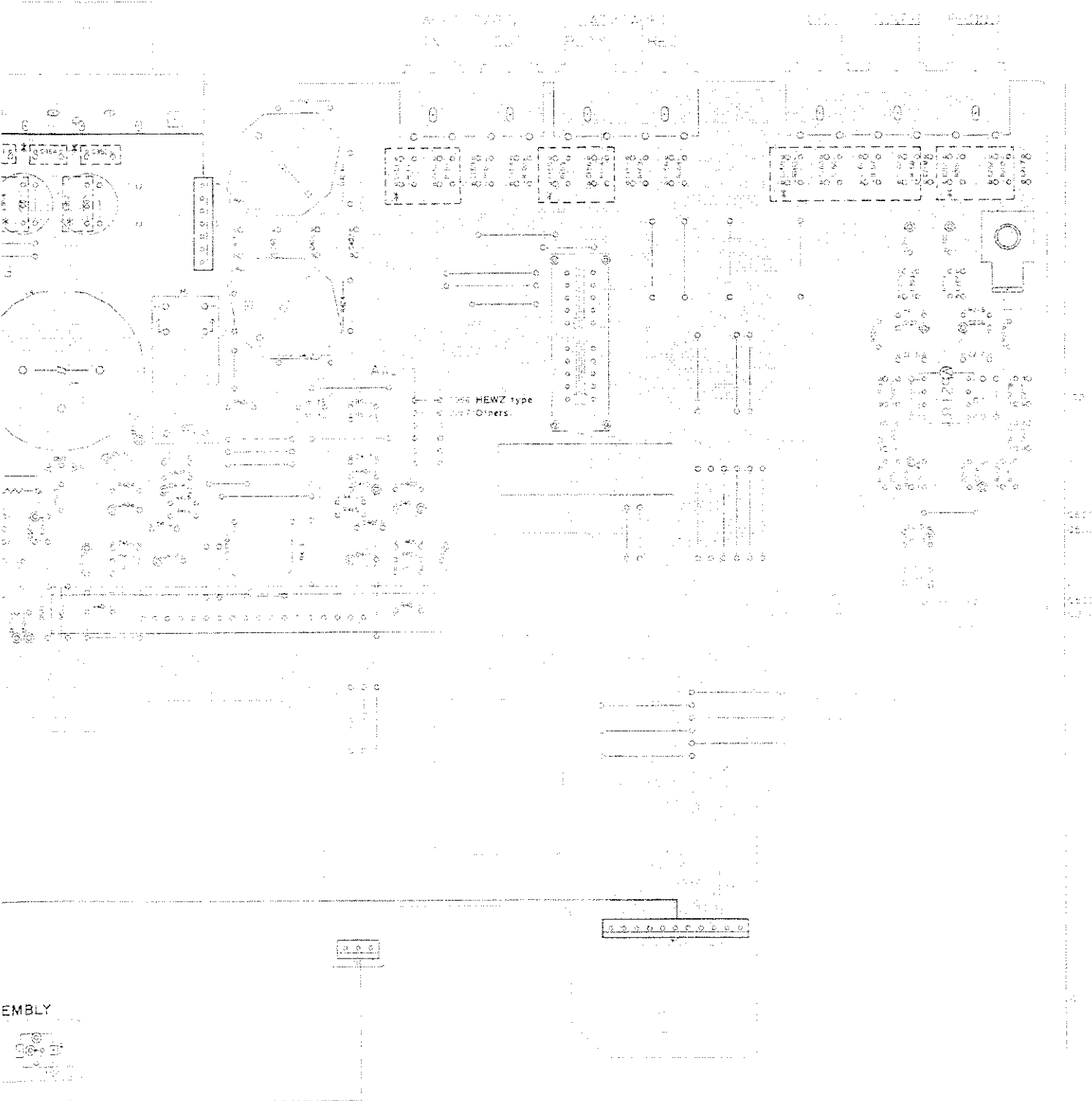

01010

01010

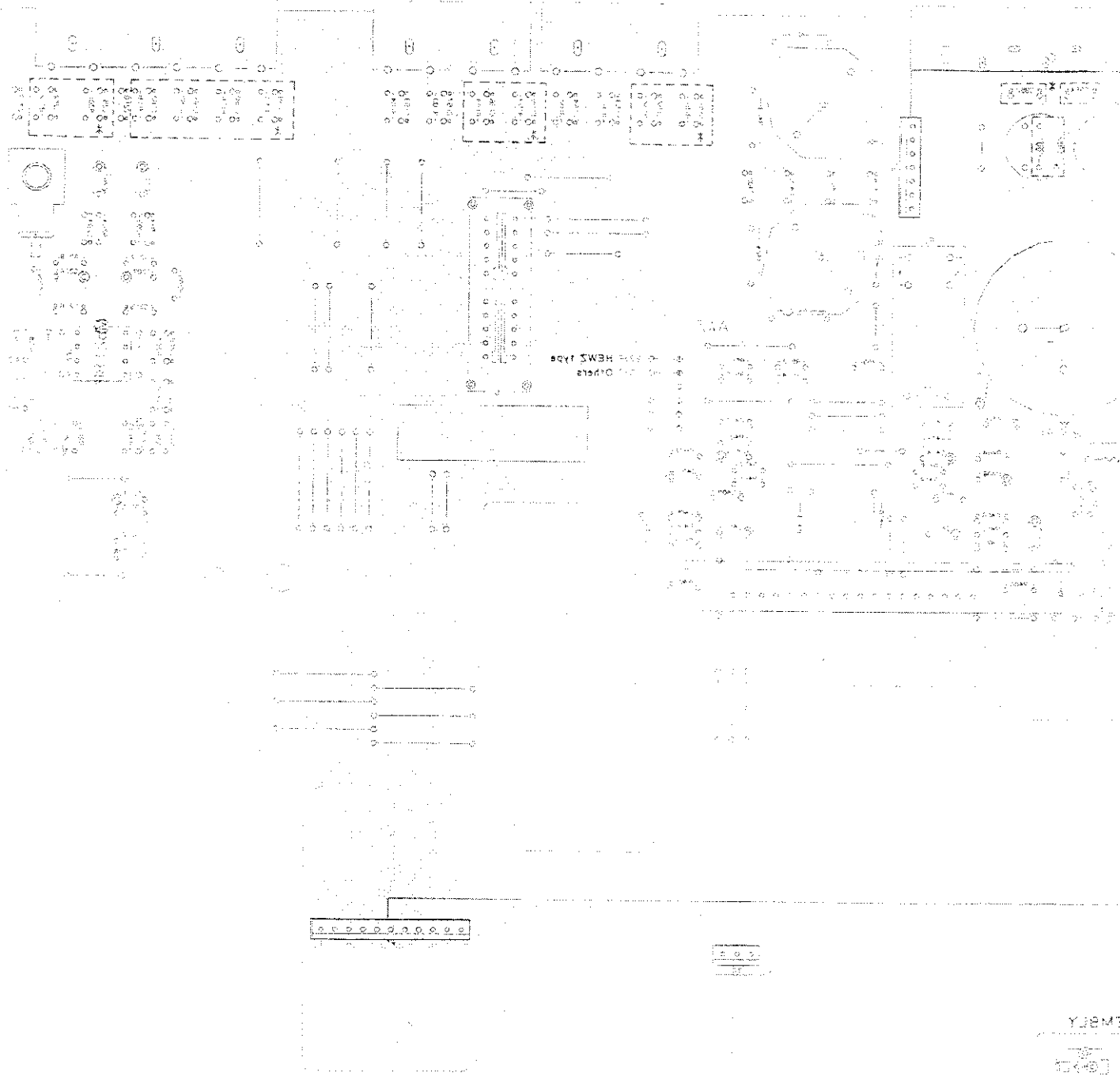

PRIMARY

01010

3.2 PCB CONNECTIONS DIAGRAM OF A-201

• View from soldering side

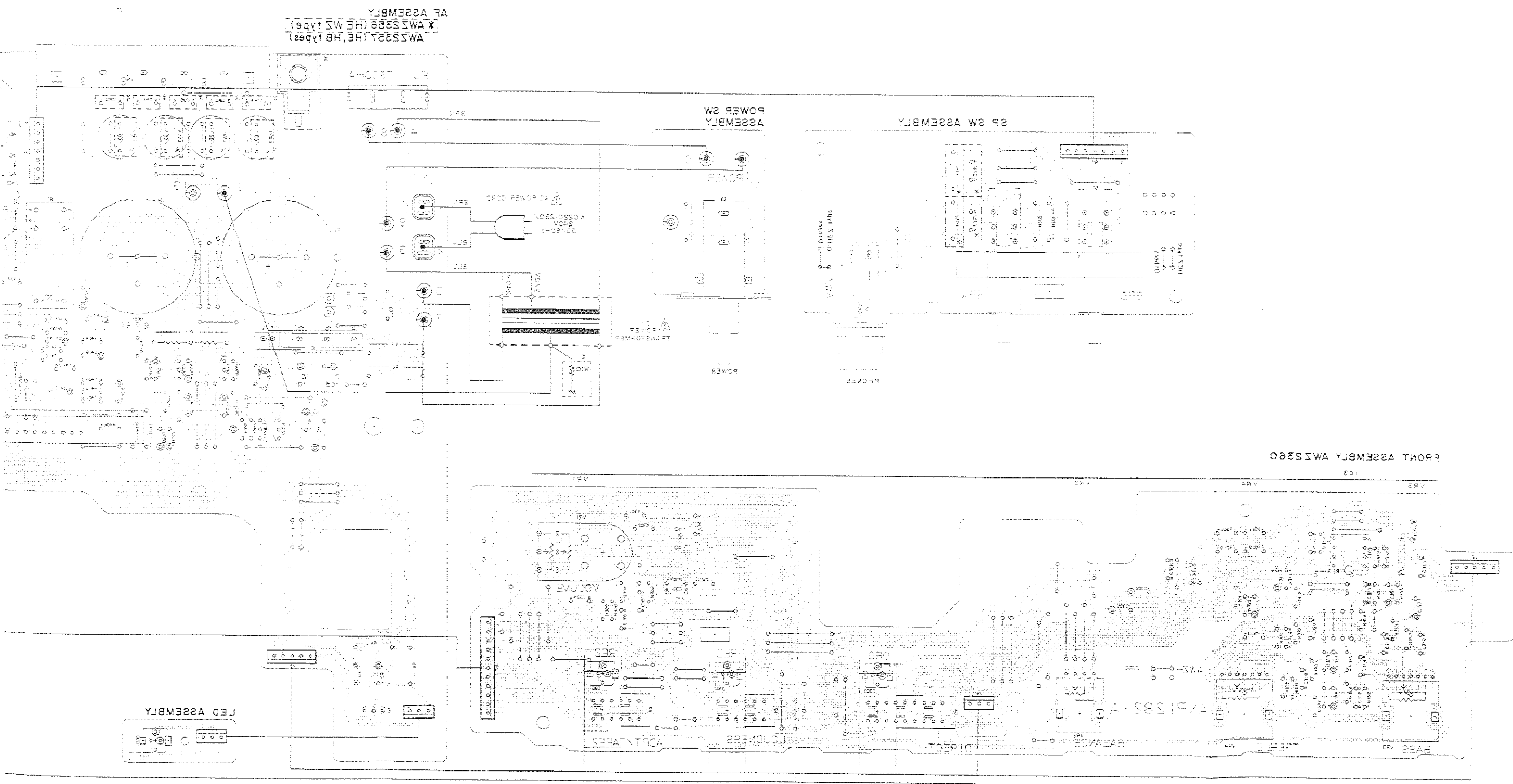

0 1 2 3 4

A

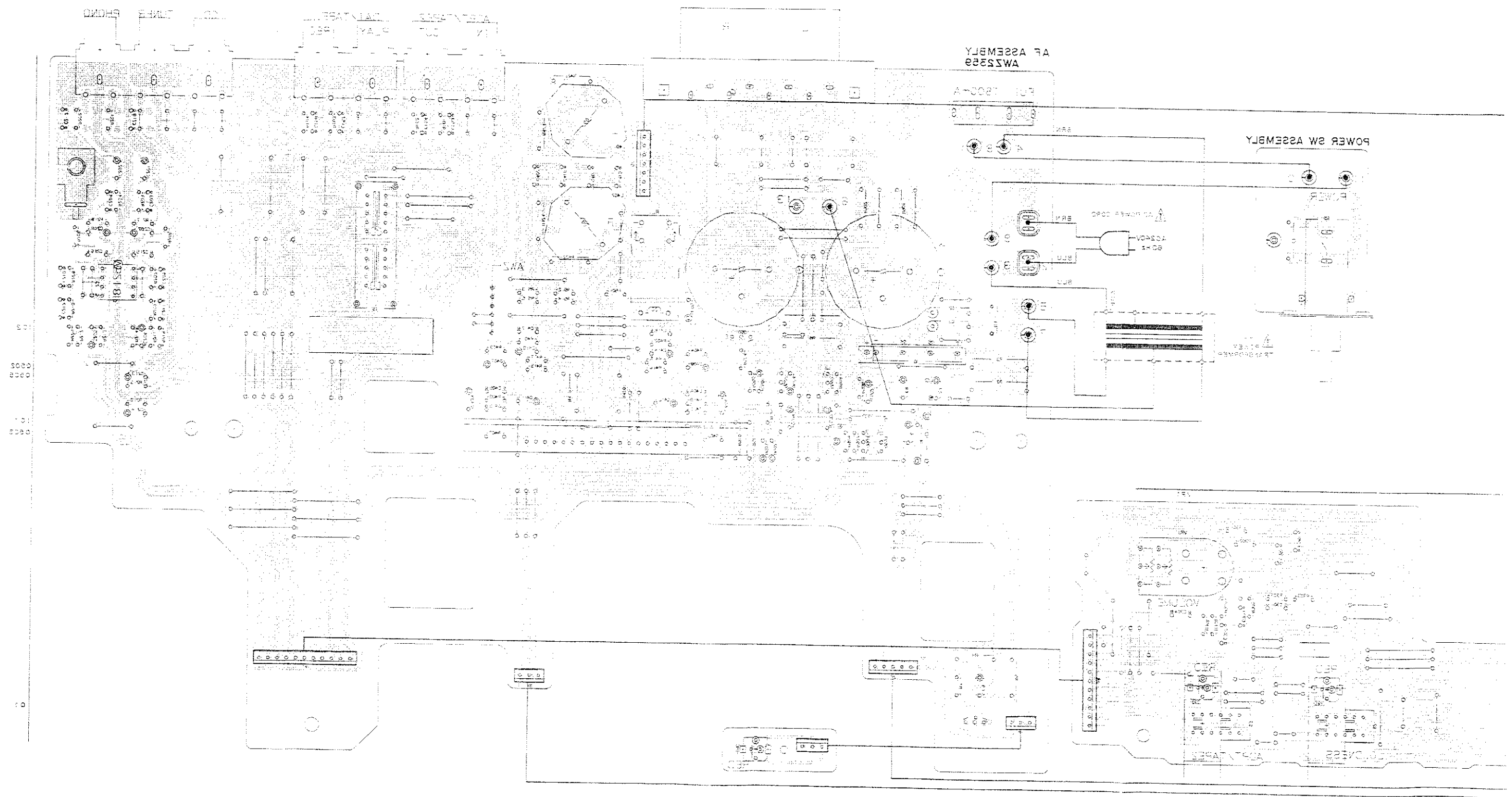

0 1 2 3 4

3.3 PCB CONNECTIONS DIAGRAM OF A-101

- View from component side

NOTES

1. The PCB connections diagram is viewed from the component side.
2. The parts which need to be mounted on the board can be verified with notes shown with their corresponding symbols listed in the following table.

PCB external symbol indication	Corresponding part symbol	Part Name
		Transistor
		Radiator Mount Transistor
		Diode
		Resistor
		Capacitor (Polarized)
		Electrolytic Capacitor

Grains

PCB external symbol indication	Part Name
	IC
	Resistor
	Diode
	Cap
	Fuse
	Variable resistor (potentiometer)

1. The capacitor symbol marked with (1) indicates a known value of terminal.
2. The variable resistor marked with (2) indicates the potentiometer side.
3. The terminal marking symbol (3) always shows two terminals.

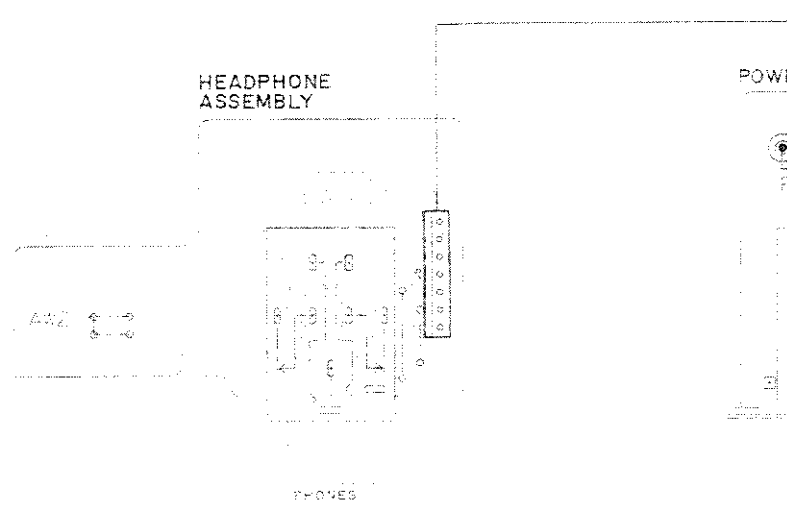

FRONT ASSEMBLY AWZ2361

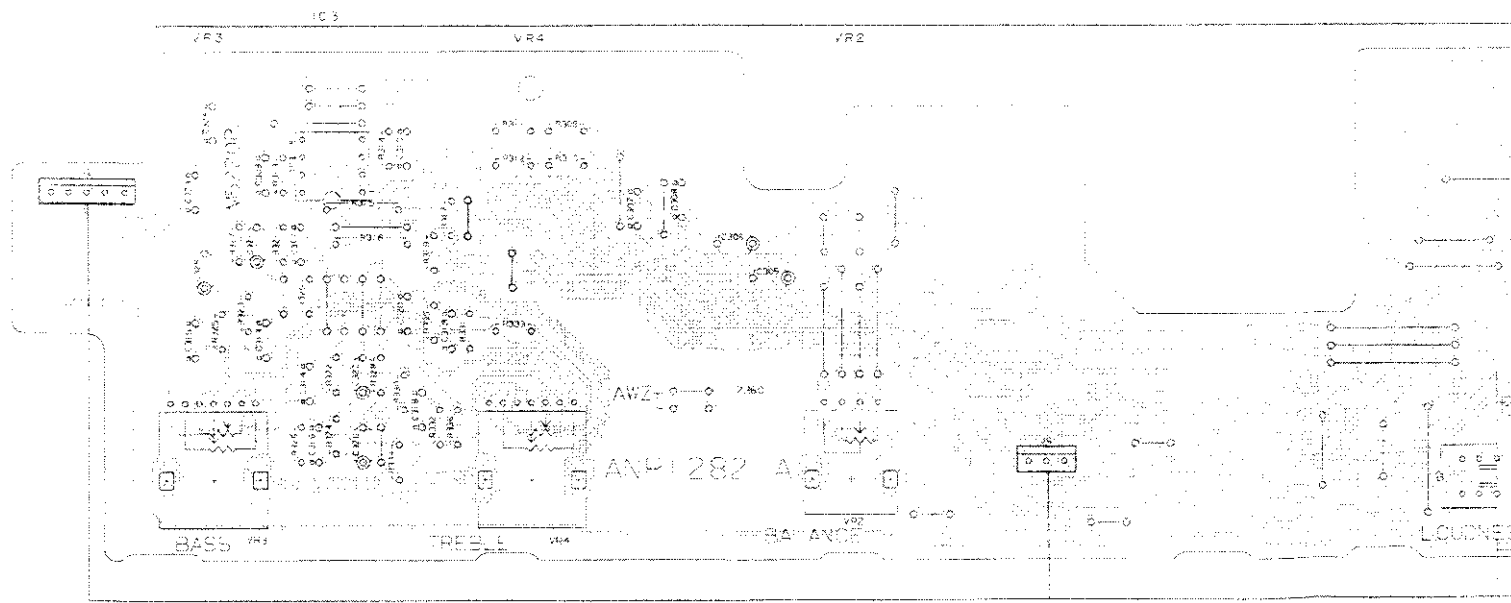

3.3 PCB CONNECTIONS DIAGRAM OF A-101

- View from soldering side

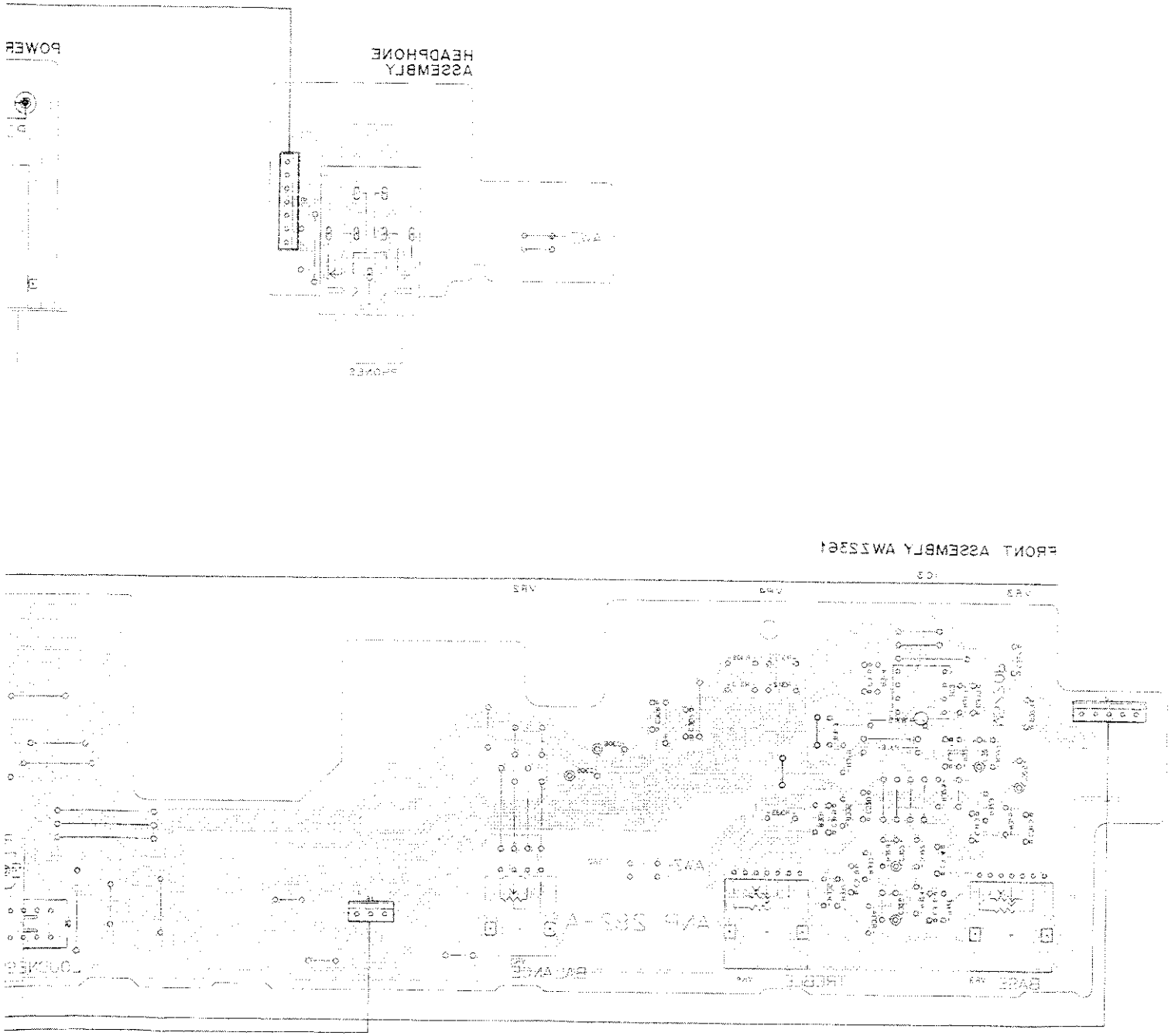

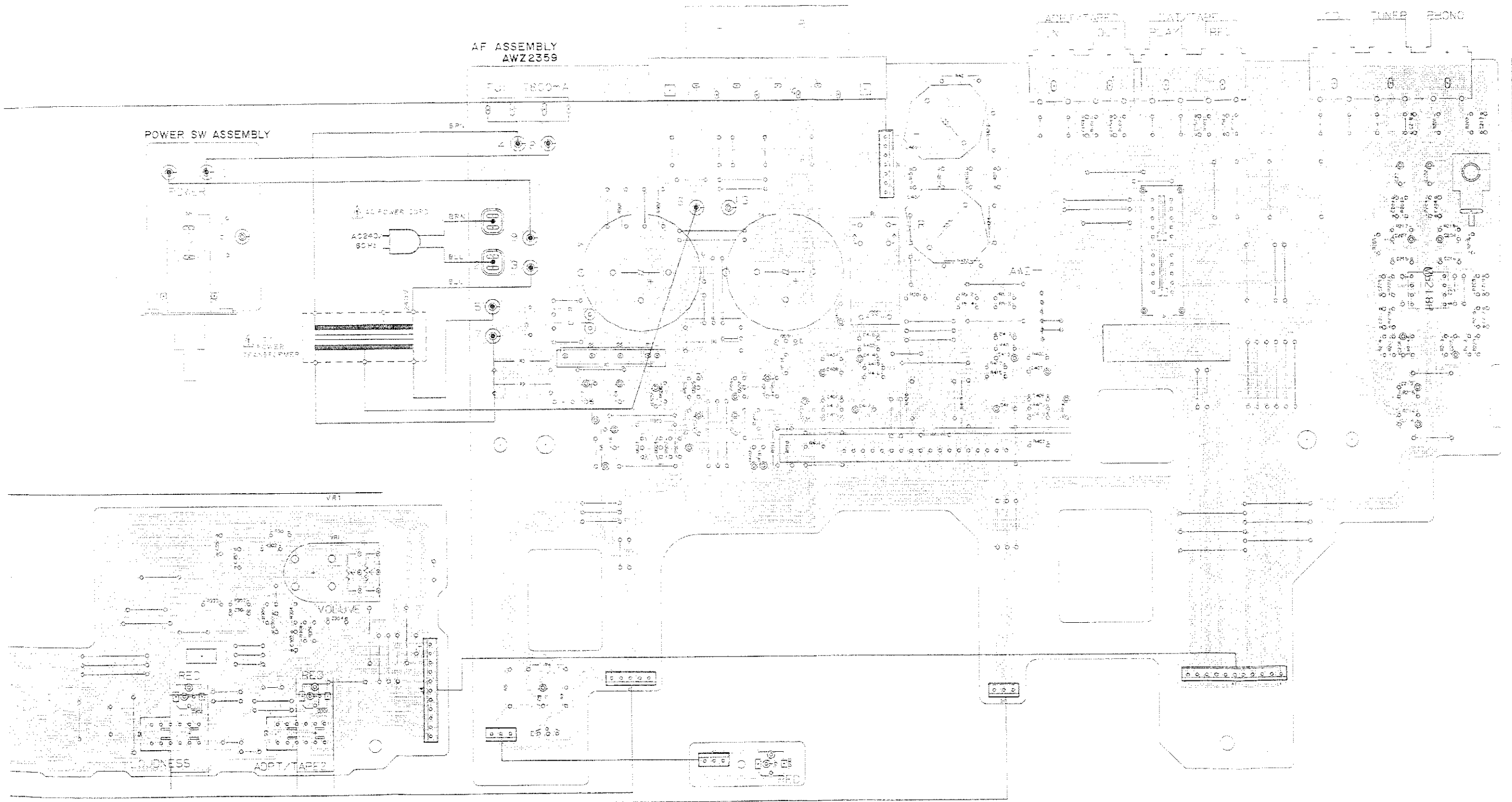

AF ASSEMBLY
AWZ2359

POWER SW ASSEMBLY

ADJUSTABLE
PLAY

TUNED
CIRCUIT

VOLUME

ADPT/TAPE2

BUSINESS

RECORD

3.4 SCHEMATIC DIAGRAM OF A-101

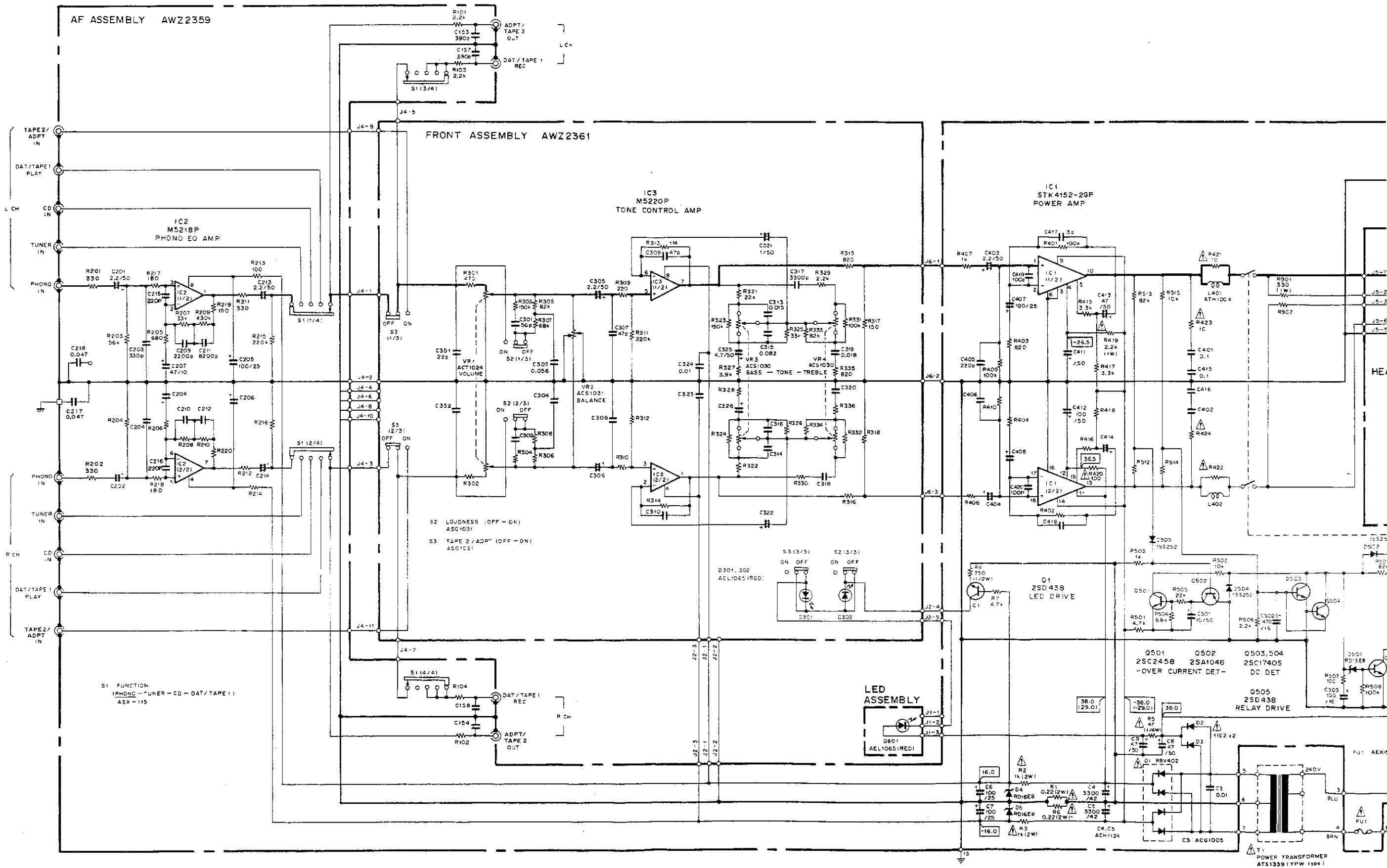

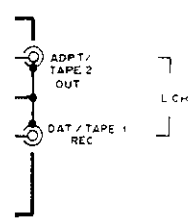

SEMBLY AWZ2361

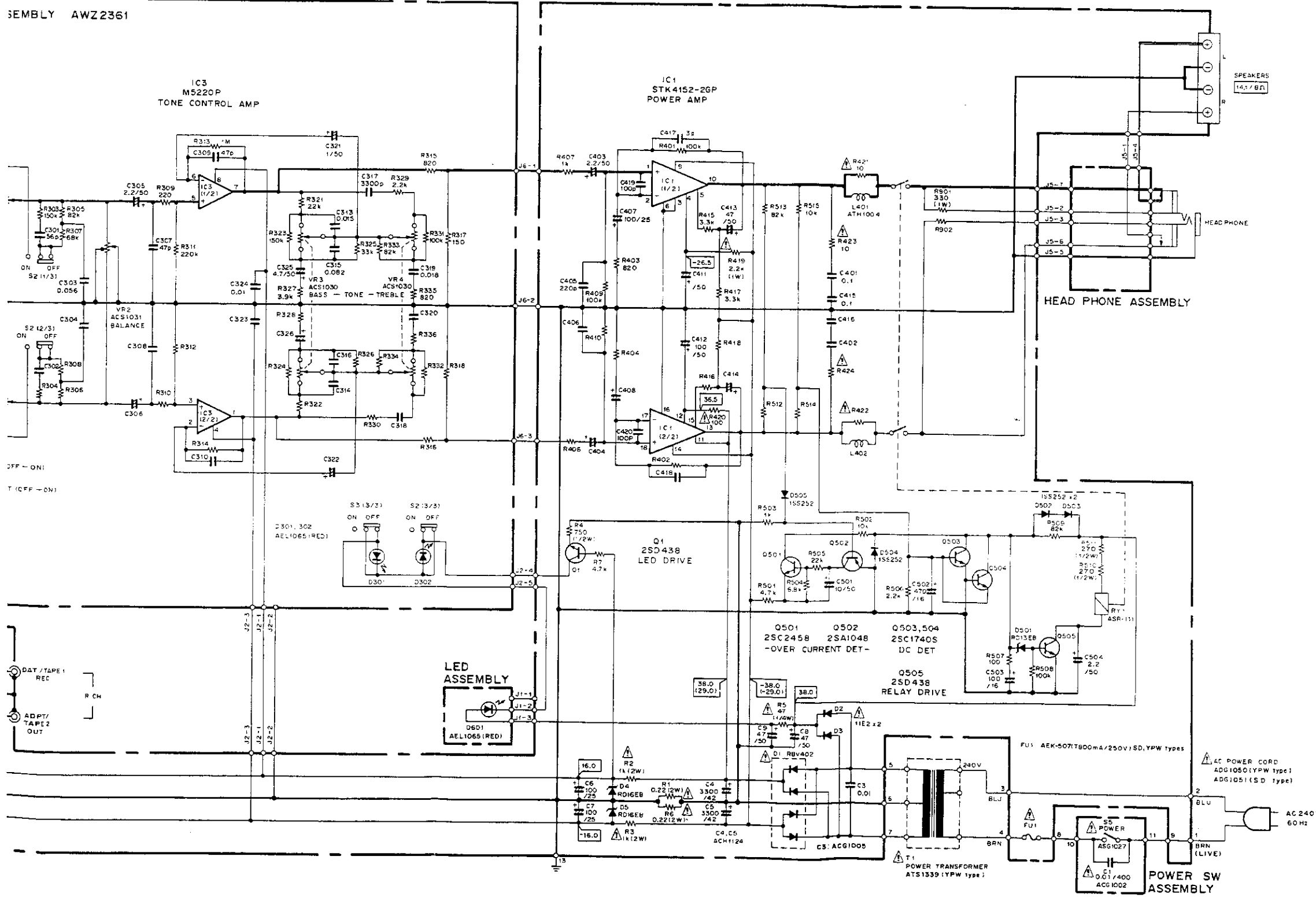

1. RESISTORS:
Indicated in Ω, 2W, 1/2W, 1/8W, ±5% tolerance unless otherwise noted k, kΩ, M, MΩ, (F): ±1%, (G): ±2%, (K): ±10%, (M): ±20% tolerance.
2. CAPACITORS:
Indicated in capacity (μF)/voltage (V) unless otherwise noted p, pF. Indication without voltage is 50V except electrolytic capacitor.
3. VOLTAGE CURRENT:
 - : Signal voltage at (25W + 25W, 8Ω) output (1kHz).
 - : DC voltage (V) at no input signal.
 - Value in () is DC voltage at rated power.
4. OTHERS:
 - : Signal route.
 - ⊗: Adjusting point.
 - △: mark found on some component parts indicates the importance of the safety factor of the part. Therefore, when replacing, be sure to use parts of identical designation.
 - *: marked capacitors and resistors have parts numbers.
5. SWITCHES (Underline indicates switch position)
 - S1: FUNCTION (PHONO-TUNER-CD-DAT/TAPE1)
 - S2: LOUDNESS (ON-OFF)
 - S3: ADPT/TAPE2 (ON-OFF)
 - S5: POWER (ON-OFF)

This is the basic schematic diagram, but the actual circuit may vary due to improvements in design.

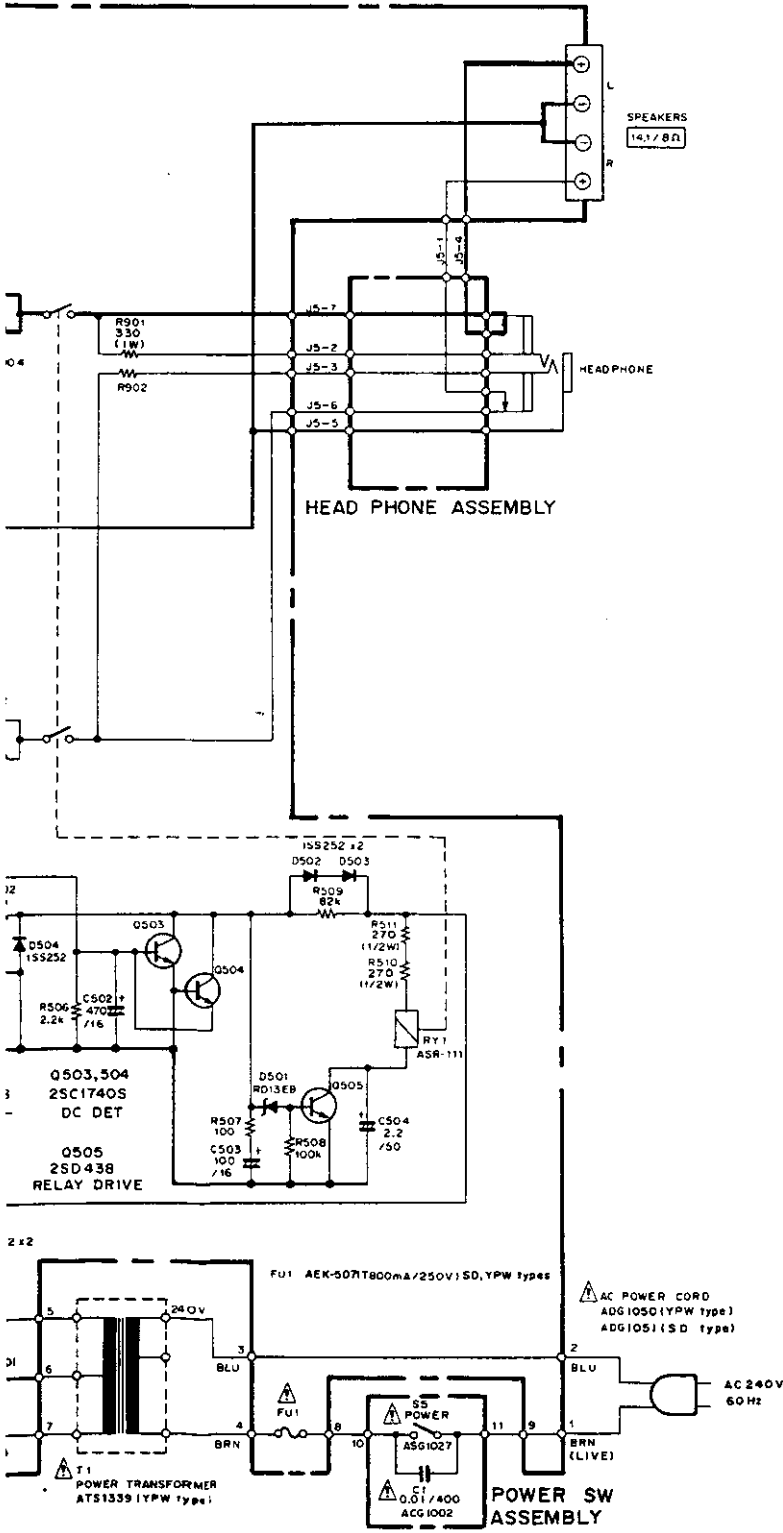

1. RESISTORS:
Indicated in Ω , 2W, 1/2W, 1/8W, $\pm 5\%$ tolerance unless otherwise noted k; k Ω , M; M Ω , (F); $\pm 1\%$, (G); $\pm 2\%$, (K); $\pm 10\%$, (M); $\pm 20\%$ tolerance.
2. CAPACITORS:
Indicated in capacity (μ F)/voltage (V) unless otherwise noted p; pF. Indication without voltage is 50V except electrolytic capacitor.
3. VOLTAGE CURRENT:

	: Signal voltage at (25W + 25W, 8 Ω) output (1kHz).
	: DC voltage (V) at no input signal
	Value in () is DC voltage at rated power.
4. OTHERS:

	: Signal route.
	: Adjusting point.

The Δ mark found on some component parts indicates the importance of the safety factor of the part. Therefore, when replacing, be sure to use parts of identical designation.

* marked capacitors and resistors have parts numbers.
5. SWITCHES (Underline indicates switch position)

S1 : FUNCTION	(<u>PHONO</u> - TUNER - CD - DAT / TAPE1)
S2 : LOUDNESS	(ON - <u>OFF</u>)
S3 : ADPT / TAPE2	(ON - <u>OFF</u>)
S5 : POWER	(ON - <u>OFF</u>)

This is the basic schematic diagram, but the actual circuit may vary due to improvements in design.

4. PCB PARTS LIST

4.1 PCB PARTS LIST OF A-201

NOTES:

- Parts marked by "NSP" are generally unavailable because they are not in our Master Spare Parts List.
- Parts marked by "⊙" are not always kept in stock. Their delivery time may be longer than usual or they may be unavailable.
- The Δ mark found on some component parts indicates the importance of the safety factor of the part. Therefore, when replacing, be sure to use parts of identical designation.
- When ordering resistors, first convert resistance values into code form as shown in the following examples.

Ex.1 When there are 2 effective digits (any digit apart from 0), such as 560 ohm and 47k ohm (tolerance is shown by J=5%, and K=10%)

560 Ω \rightarrow $56 \times 10^0 \rightarrow$ 561 RD1/4PS $\begin{matrix} 5 & 6 & 1 \\ \square & \square & \square \end{matrix}$ J
 47k Ω \rightarrow $47 \times 10^3 \rightarrow$ 473 RD1/4PS $\begin{matrix} 4 & 7 & 3 \\ \square & \square & \square \end{matrix}$ J
 0.5 Ω \rightarrow 0R5 RN2H $\begin{matrix} 0 & R & 5 \\ \square & \square & \square \end{matrix}$ K
 1 Ω \rightarrow 010 RS1P $\begin{matrix} 0 & 1 & 0 \\ \square & \square & \square \end{matrix}$ K

Ex.2 When there are 3 effective digits (such as in high precision metal film resistors).

5.62k Ω \rightarrow $562 \times 10^1 \rightarrow$ 5621 RN1/4SR $\begin{matrix} 5 & 6 & 2 & 1 \\ \square & \square & \square & \square \end{matrix}$ F

LIST OF ASSEMBLIES

Mark	Description	Part No.
⊙	AF assembly	AWZ2356
⊙	Front assembly	AWZ2360
NSP	Power SW assembly	AWZ2362
NSP	LED assembly	AWZ2363
NSP	SP SW assembly	AWZ2364

AF assembly

SEMICONDUCTORS

Mark	Description	Part No.
	IC2	MS218P
	IC1	STK4181 - SG
	Q502	2SA1048
	Q503, Q504	2SC1740S
	Q501	2SC2240
	Q1, Q505	2SD438
Δ	D1	RBV802
	D501	RD13EB
	D4, D5	RD16EB
	D602 - D605	1SS252
Δ	D2, D3	11E2

SWITCH AND RELAY

Mark	Description	Part No.
	RY1 Relay	ASR - 111
	S1 Remote slide switch	ASX - 115

COILS

Mark	Description	Part No.
	L951 - L954 AF choke coil	ATH - 133
	L401, L402 AF choke coil	ATH1004

CAPACITORS

Mark	Description	Part No.
	C4, C5 (6800 μ F / 56V)	ACH1124
	C417, C418	CCDSL030C50
	C409, C410	CCDSL050C50
	C419, C420	CCDSL101J50
	C405, C406	CCDSL221J50
	C501	CEAS100M50
	C205, C206, C407, C408	CEXA101M25
	C6, C7, C503	CEAS101M25
	C412	CEAS101M50
	C201, C202, C213, C214, C403, C404, C504, C505	CEAS2R2M50
	C411	CEAS220M50
	C207, C208, C413, C414	CEXA470M50
	C8, C9	CEAS470M50
	C502	CEAS471M5
	C203, C204	CKDYB331K50
	C151 - C162, C215, C216, C251, C252	CKDYB391K50
	C951 - C955	CKDYB472K50
	C217, C218	CKDYP473Z50
	C401, C402, C415, C416	CQMA104J50
	C209, C210	CQMA222J50
	C211, C212	CQMA822K50
	C3	CQMXA104J100

RESISTORS

Mark	Description	Part No.
Δ	R1	ACN - 146
Δ	R419	RS1LMF222J
Δ	R2, R3	RS2LMF102J
Δ	R421 - R424	RD1/4PMFL100J
	R5	RFA1/4PS331J
	R4, R510, R511	RD1/4PMF $\begin{matrix} \square & \square & \square \\ \square & \square & \square \end{matrix}$ J
	Other resistors	RD1/4PM $\begin{matrix} \square & \square & \square \\ \square & \square & \square \end{matrix}$ J

OTHERS

Mark	Description	Part No.
	Pin jack 4P	AKB1007
	Pin jack 6P	AKB1008
	Speaker terminal 8P	AKE - 111

Front assembly

SEMICONDUCTORS

Mark	Description	Part No.
	IC3	M5220P
	D301, D302	AEL1065
	D303	AEL1084

SWITCHES

Mark	Description	Part No.
	S4 Switch	ASG1030
	S2, S3 Push switch	ASG1031

CAPACITORS

Mark	Description	Part No.
	C351, C352	CCDSL220J50
	C307 - C310	CCDSL470J50
	C301, C302	CCDSL560J50
	C321, C322	CEAS010M50
	C305, C306	CEAS2R2M50
	C311, C312, C325, C326	CEAS4R7M50
	C303, C304	CFTXA563J50
	C323, C324	CKDYF103Z50
	C313, C314	CQMA153K50
	C319, C320	CQMA183K50
	C317, C318	CQMA332K50
	C315, C316	CQMA823K50

RESISTORS

Mark	Description	Part No.
	VR3, VR4 Variable resistor	ACS1030
	VR2 Variable resistor	ACS1031
	VR1 Variable resistor	ACT1024
	Other resistors	RD 1/4 PM □ □ □ J

Power SW assembly

SWITCH

Mark	Description	Part No.
△	S5 Push switch (POWER)	ASG1027

CAPACITOR

Mark	Description	Part No.
△	C1 (0.01 μ F / 400V)	ACG1002

LED Assembly

SEMICONDUCTORS

Mark	Description	Part No.
	D601	AEL1065

SP SW Assembly

SWITCH

Mark	Description	Part No.
	S6 Push switch	SUL5LXBXS

CPACITORS

Mark	Description	Part No.
	C751, C752	CKDYB392K50

RESISTORS

Mark	Description	Part No.
△	R701, R702	RS2LMF331J
	Other resistors	RD 1/4 PMF □ □ □ J

OTHERS

Mark	Description	Part No.
	Jack (PHONES)	AKN1002

4.2 PCB PARTS LIST OF A-101

LIST OF ASSEMBLIES

Mark	Description	Part No.
⊙	AF assembly	AWZ2359
⊙	Front assembly	AWZ2361
NSP	Power SW assembly	AWZ2362
NSP	LED assembly	AWZ2363
NSP	Headphone assembly	AWZ2367

AF assembly

SEMICONDUCTORS

Mark	Description	Part No.
	IC2	M5218P
	IC1	STR4152 - 2GP
	Q502	2SA1048
	Q503, Q504	2SC1740S
	Q501	2SC2458
△	Q1, Q505	2SD438
	D1	RBV402
	D501	RD13EB
	D4, D5	RD16EB
	D502 - D505	1SS252
△	D2, D3	11E2

SWITCH AND RELAY

Mark	Description	Part No.
	RY1 Relay	ASR - 111
	S1 Remote slide switch	ASX - 115

COILS

Mark	Description	Part No.
	L401, L402 AF choke coil	ATH1004

CAPACITORS

Mark	Description	Part No.
	C4, C5 (3300 μ F / 42V)	ACH1123
	C417, C418	CCDSL030C50
	C419, C420	CCDSL101J50
	C215, C216, C405, C406	CCDSL221J50
	C501	CEAS100M50
	C407, C408	CEAS101M10
	C503	CEAS101M16
	C5, C7, C205, C206	CEAS101M25
	C412	CEAS101M50
	C201, C202, C213, C214, C403, C404, C504	CEAS2R2M50
	C207, C208	CEAS470M10
	C8, C9, C411, C413, C414	CEAS470M50
	C502	CEAS471M6
	C203, C204	CKDYB331K50
	C153, C154, C157, C158	CKDYB391K50

Mark	Description	Part No.
	C217, C218	CKDYF473Z50
	C401, C402, C415, C416	CQMA104J50
	C209, C210	CQMA222J50
	C211, C212	CQMA822K50

Mark	Description	Part No.
	C3	ACG1005

RESISTORS

Mark	Description	Part No.
△	R421 - R424	RD 1/4 PMFL100J
△	R420	RFA 1/4 PL101J
	R5	RFA 1/4 PS470J
△	R419	RS1LMF222J
△	R1, R6	RS2LMFR22J
	R901, R902	RS1LMF331J
△	R2, R3	RS2LMF102J
	R4, R510, R511	RD 1/4 PMF □ □ □ J
	Other resistors	RD 1/4 PM □ □ □ J

OTHERS

Mark	Description	Part No.
	Pin jack 4P	AKB1007
	Pin jack 6P	AKB1008
	Speaker terminal 4P	AKE - 109

Front assembly

SEMICONDUCTORS

Mark	Description	Part No.
	IC3	M5220P
	D301, D302	AEL1065

SWITCHES

Mark	Description	Part No.
	S2, S3 Push switch	ASG1031

CAPACITORS

Mark	Description	Part No.
	C351, C352	CCDSL220J50
	C307 - C310	CCDSL470J50
	C301, C302	CCDSL560J50
	C321, C322	CEAS010M50
	C305, C306	CEAS2R2M50
	C325, C326	CEAS4R7M50
	C303, C304	CFTXA563J50
	C323, C324	CKDYF103Z50
	C313, C314	CQMA153K50
	C319, C320	CQMA183K50
	C317, C318	CQMA332K50
	C315, C316	CQMA823K50

RESISTORS

<u>Mark</u>	<u>Description</u>	<u>Part No.</u>
	VR3, VR4 Variable resistor	ACS1030
	VR2 Variable resistor	ACS1031
	VR1 Variable resistor	ACT1024
	Other resistor	RD ¼ PM □ □ □ J

Power SW Assembly

SWITCH

<u>Mark</u>	<u>Description</u>	<u>Part No.</u>
△	S5 Push switch (POWER)	ASG1027

CAPACITOR

<u>Mark</u>	<u>Description</u>	<u>Part No.</u>
△	C1 (0.01 μ F / 400V)	ACG1002

LED Assembly

SEMICONDUCTORS

<u>Mark</u>	<u>Description</u>	<u>Part No.</u>
	D601	AEL1065

Headphone Assembly

OTHER

<u>Mark</u>	<u>Description</u>	<u>Part No.</u>
	Jack (PHONES)	AKN1010

5. FOR A-201/HE, HB AND SD TYPES

CONTRAST OF MISCELLANEOUS PARTS

NOTES:

- Parts marked by "NSP" are generally unavailable because they are not in our Master Spare Parts List.
- The Δ mark found on some component parts indicates the importance of the safety factor of the part. Therefore, when replacing, be sure to use parts of identical designation.
- Parts marked by "⊙" are not always kept in stock. Their delivery time may be longer than usual or they may be unavailable.

A-201/HE, HB, SD and A-201/HEWZ have the same construction except for the following:

Mark	Symbol & Description	Part No.				Remarks
		A-201/HEWZ type	A-201/HE type	A-201/HB type	A-201/SD type	
⊙ NSP	AF assembly	AWZ2358	AWZ2357	AWZ2357	AWZ2460	
NSP	SP SW assembly	AWZ2364	AWZ2365	AWZ2365	AWZ2365	
Δ	AC power cord	ADG1049	ADG1049	ADG1087	ADG1051	
NSP	Name sticker	AAL1947	AAL1948	AAL1949	AAL1950	
	Operating instructions (German)	ARC1354	
	Operating instructions (English/French/German/Italian/Dutch/Swedish/Spanish/Portuguese)	ARE1241	
	Operating instructions (English)	ARB1372	ARB1372	
	Operating instructions (Spanish)	ARC1355	
Δ	FU2 Fuse (1.25A/250V)	AEK - 508	
Δ	3P AC outlet	AKP - 515	(Rear panel)
Δ	S7 Line voltage selector (AC110/120 - 127/220/240V)	AKX - 507	(Rear panel)
Δ	Insulator assembly	AMR2140	AMR2140	AMR2140	AMR2141	
Δ	Power transformer (AC220 - 230/240V)	ATS1338	ATS1338	ATS1338	
Δ	Power transformer (AC110/120 - 127/220/240V)	ATS1190	
NSP	Rear panel	ANC1365	ANC1365	ANC1365	ANC1715	
	R10 Resistor	RD1/4PMF4R7J	(Power transformer ↔ chassis)

AF ASSEMBLY

AWZ2357, AWZ2460 and AWZ356 have the same construction except for the following:

Mark	Symbol & Description	Part No.			Remarks
		AWZ2356	AWZ2357	AWZ2460	
⊙	C3	CQMXA104J100	ACG1005	ACG1005	
NSP	C151, 152, 155, 158, 159-182, 251, 252	CKDYB391K50	
Δ	C215, 216	CKDYB391K50	CCDSL221J50	CCDSL221J50	
NSP	C409, 410	CCDSL050C50	CCDSL020C50	CCDSL020C50	
	C415, 420	CCDSL101J50	CCDSL151C50	CCDSL151J50	
	C951-955	CKDYB472K50	
	L851-854	ATH-133	
	R151-158	RD1/8PM102J	
	R201, 202	RD1/8PM152J	RD1/8PM331J	RD1/8PM331J	
	R217, 218	RD1/8PM221J	RD1/8PM181J	RD1/8PM181J	

NOTE: For schematic diagram and PCB connections diagram, refer to pages 6 - 11, 30.

SP SW ASSEMBLY

AWZ2365 and AWZ2364 have the same construction except for the following:

Mark	Symbol & Description	Part No.		Remarks
		AWZ2364	AWZ2365	
	C751, 752	CKDYB392K50	
	R751, 752	RD1/2PMF681J	

6. FOR A-101/SD TYPE

CONTRAST OF MISCELLANEOUS PARTS

NOTES:

- Parts marked by "NSP" are generally unavailable because they are not in our Master Spare Parts List.
- The Δ mark found on some component parts indicates the importance of the safety factor of the part. Therefore, when replacing, be sure to use parts of identical designation.
- Parts marked by "⊙" are not always kept in stock. Their delivery time may be longer than usual or they may be unavailable.

A-101/SD and A-101/YPW have the same construction except for the following:

Mark	Symbol & Description	Part No.		Remarks
		A-101/YPW type	A-101/SD type	
⊙	AF assembly	AWZ2359	AWZ2461	
Δ	AC power cord	ADG1050	ADG1051	
Δ	Power transformer (AC240V)	ATS1339	
Δ	Power transformer (AC110/120-127/220/240V)	ATS1192	
Δ	3P AC outlet	AKP-515	
Δ	FU2 Fuse (T800mA/250V)	AEK-507	
Δ	S7 Line voltage selector (AC110/120-127/220/240V)	AKX-507	(Rear panel)
	Operating instructions (Spanish)	ARC1355	
NSP	Name sticker	AAL1952	AAL1951	
NSP	Rear panel	ANC1363	ANC1716	

AF ASSEMBLY

Although AWZ2461 and AWZ2359 are different in part number, they have the same service parts.

SCHEMATIC DIAGRAM AND P.C.BOARD PATTERN
For A-201/SD and A-101/SD types

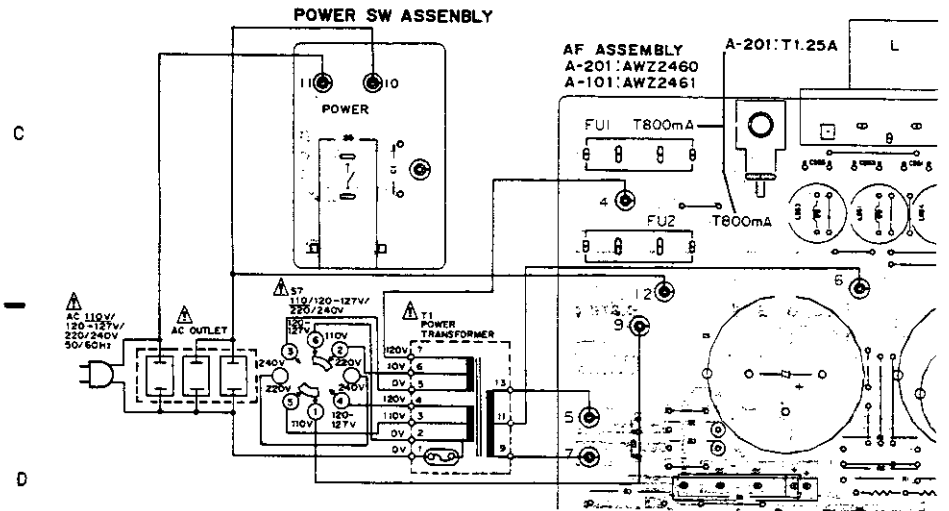
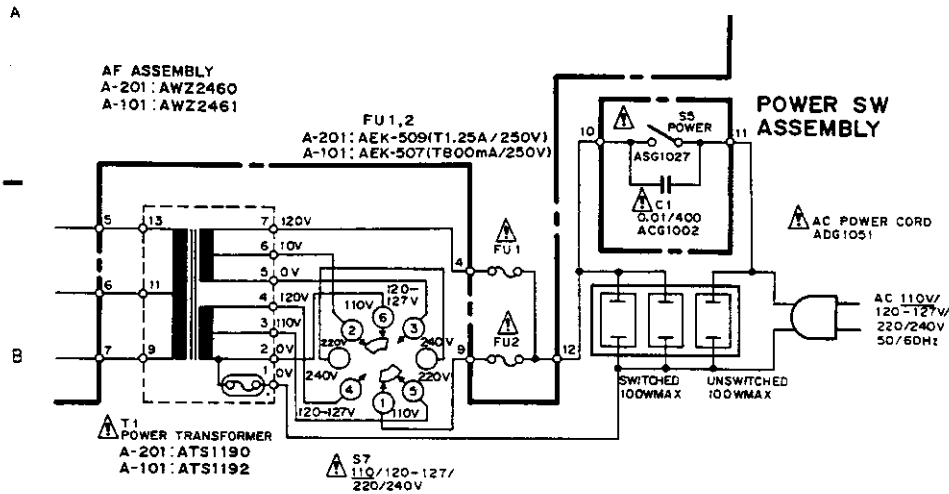

7. SPECIFICATIONS

[A-201]

Amplifier Section

Continuous power output
(both channels driven at 20 Hz to 20 kHz)**
T.H.D. 0.07 %, 8 Ω 35 W + 35 W*
DIN Continuous power output (both channels driven at 1 kHz)
T.H.D. 1.0 %, 8 Ω 40 W + 40 W
T.H.D. 1.0 %, 4 Ω 50 W + 50 W
Dynamic power output (E.I.A test signal)
4 Ω 66 W
Total harmonic distortion**
20 Hz to 20 kHz, 35 W, 8 Ω 0.07 %*

* Power output specification is for when power supply is 230 V.
Input sensitivity/impedance
PHONO (MM) 2.5 mV/50 kΩ
CD, TUNER, DAT/TAPE 1, ADPT/TAPE 2 150 mV/50 kΩ
PHONO overload level
1 kHz, T.H.D. 0.1 % (MM) 150 mV

Output level/impedance
TAPE REC, ADPT OUT 150 mV/2.2 kΩ
Frequency response
PHONO (MM) 20 Hz to 20 kHz ± 0.5 dB
CD, TUNER, DAT/TAPE 1, ADPT/TAPE 2 10 Hz to 50 kHz ± 1 dB*

Tone control (volume control set at -30 dB position)
BASS ± 8 dB (100 Hz)
TREBLE ± 8 dB (10 kHz)
Loudness contour (volume control set at -30 dB position)
..... +6 dB (100 Hz)/+3 dB (10 kHz)
Signal-to-Noise ratio (IHF short circuit, A network)
PHONO (MM, 5 mV input) 77 dB*
CD, TUNER, DAT/TAPE 1, ADPT/TAPE 2 100 dB*
Signal-to-Noise ratio (DIN, continuous power/50 mW)
PHONO (MM) 67 dB/61 dB*
CD, TUNER, DAT/TAPE 1, ADPT/TAPE 2 83 dB/63 dB*

Power Supply/Miscellaneous

Power requirements a.c. 220 - 230 Volts, 50/60 Hz
Power consumption 330W
Dimensions (including knobs and other protruding parts)
..... 420 (W) x 282 (D) x 103 (H) mm
Weight (without package) 5.6 kg

Accessories

Operating instructions 1

NOTE:

Specifications and design subject to possible modification without notice, due to improvements.

- * Measured with the DIRECT switch set to ON. For ADPT/TAPE 2, however, measured with the DIRECT switch set to OFF and the tone and balance controls in center position.
- ** Measured by Audio Spectrum Analyzer.

[A-101]

Amplifier Section

Continuous power output (both channels driven at 30 Hz to 20 kHz)**
T.H.D. 0.2 %, 8 Ω 25 W + 25 W*
DIN Continuous power output (both channels driven at 1 kHz)
T.H.D. 1.0 %, 8 Ω 30 W + 30 W

Total harmonic distortion**
30 Hz to 20 kHz, 25 W, 8 Ω 0.2 %*
Input sensitivity/impedance
PHONO (MM) 2.5 mV/50 kΩ
CD, TUNER, DAT/TAPE 1, ADPT/TAPE 2 150 mV/50 kΩ
PHONO overload level
1 kHz, T.H.D. 0.1 % (MM) 150 mV
Output level/impedance
TAPE REC, ADAPTOR OUTPUT 150 mV/2.2 kΩ

Frequency response
PHONO (MM), 30 Hz to 20 kHz ± 0.5 dB
CD, TUNER, DAT/TAPE 1, ADPT/TAPE 2, 10 Hz to 50 kHz
..... ± 1 dB*

Tone control (volume control set at -30 dB position)
BASS ± 8 dB (100 Hz)
TREBLE ± 8 dB (10 kHz)
Loudness control (volume control set at -30 dB position)
..... +6 dB (100 Hz)/+3 dB (10 kHz)

Signal-to-Noise ratio (IHF short circuit, A network)
PHONO (MM, 5 mV input) 77 dB*
CD, TUNER, DAT/TAPE 1, ADPT/TAPE 2 95 dB*
Signal-to-Noise ratio (DIN, continuous power/50 mW)
PHONO (MM) 63 dB/60 dB*
CD, TUNER, DAT/TAPE 1, ADPT/TAPE 2 81 dB/62 dB*

Power Supply/Miscellaneous

Power requirements
Australian model a.c. 240 V, 50/60 Hz
Other destination models
..... AC110V/120 - 127V/220V/240V (switchable) 50/60 Hz
Power Consumption 210 W
Dimensions (including knobs and other protruding parts)
Australian and other destination models
..... 420 (W) x 282 (D) x 98 (H) mm
Weight (without package) 4.6 kg

Accessories

Operating instructions 1

NOTE:

Specifications and design subject to possible modification without notice, due to improvements.

- * Measured with tone and balance controls set to center position.
- ** Measured by Audio Spectrum Analyzer.

8. PANEL FACILITIES

The illustration shows model A-201.
Model A-101 is not equipped with ⑥, ⑩ and ⑪.

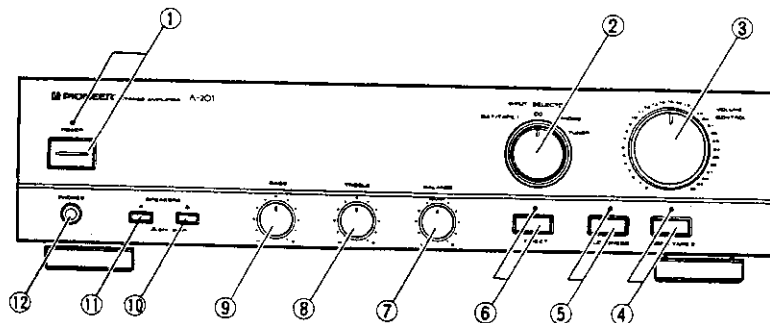

① POWER switch/indicator

Press to turn power to the unit ON and OFF.

ON:

Indicator lights.

OFF:

Indicator goes out.

② INPUT SELECTOR switch

Use to select the playback source.

TUNER:

For AM or FM broadcast reception with a tuner.

PHONO:

For record playback with a turntable.

CD:

For compact disc playback with a CD player.

DAT/TAPE 1:

For playback with a cassette deck or digital audio tape deck connected to the DAT/TAPE 1 terminals.

③ VOLUME CONTROL

Use to adjust the volume level.

④ ADPT/TAPE 2 monitor switch/indicator

Use when there is an adaptor component (graphic equalizer, etc.) or cassette deck connected to the ADPT/TAPE 2 terminals.

OFF:

Indicator goes out when not in use.

ON:

Indicator lights when using the adaptor component or listening to the cassette deck.

NOTE:

- When no connections are made to the ADPT/TAPE 2 terminals, or when they are not in use, be sure to set this switch to the OFF position. (No sound will be heard if it is set to ON position)
- When the DIRECT switch is set to ON, the input to be reproduced is always selected with the INPUT SELECTOR, regardless of whether the ADPT/TAPE 2 indicator lights or not. Furthermore, when the ADPT/TAPE 2 indicator is ON, signals input through ADPT/TAPE 2 are output at DAT/TAPE 1 REC OUT. (A-201 only)

⑤ LOUDNESS switch/indicator

Use when listening at low volume levels.

ON:

The indicator lights: Boosts low and high frequencies to give added punch to playback even at low volume levels.

OFF:

The indicator goes off: Should normally be left in this position.

⑥ DIRECT switch/indicator

(A-201 only)

Use this switch when you do not wish to pass the output from input terminal equipment through the various frequency adjusting circuits (BASS, TREBLE, BALANCE.)

ON:

The indicator lights: The signals input through the input terminals are reproduced without passing through the various frequency adjusting circuits. This results in flat, pure sound which is a more faithful reproduction of the input source.

OFF:

The indicator goes out: The signal passes through the various frequency adjusting circuits.

⑦ BALANCE control

Should normally be left in the center position. Adjust the balance if the sound is louder from one of the speakers. If the right side is louder, turn toward the L (left) position and if the left side is louder, turn toward the R (right) position.

NOTE:

This control does not operate when the DIRECT switch is in the ON position. (A-201 only)

⑧ TREBLE tone control

Use to adjust the high-frequency tone. The center position is the flat (normal) position. When turned to the right, high-frequency tone is emphasized; when turned to the left, high-frequency tone is de-emphasized.

NOTE:

This control does not operate when the DIRECT switch is in the ON position. (A-201 only)

⑨ BASS tone control

Use to adjust the low-frequency tone. The center position is the flat (normal) position. When turned to the right, low-frequency tone is emphasized; when turned to the left, low-frequency tone is de-emphasized.

NOTE:

This control does not operate when the DIRECT switch is in the ON position. (A-201 only)

⑩ SPEAKERS B selector switch

(A-201 only)

Use this switch to listen to the speaker systems connected to the SPEAKERS B terminals.

ON ():

Depressed position: Sound is heard from the speaker systems.

OFF ():

Released position: No sound is heard from the speaker systems. Set to this position when listening with headphones.

⑪ SPEAKERS A selector switch

(A-201 only)

Use this switch to listen to the speaker systems connected to the SPEAKERS A terminals.

ON ():

Depressed position: Sound is heard from the speaker systems.

OFF ():

Released position: No sound is heard from the speaker systems. Set to this position when listening with headphones.

⑫ PHONES jack

When using headphones, insert the plug into this jack. With model A-101 the output to the speakers is cut automatically when connecting headphones.