

# Service Manual

 **PIONEER®**  
The Art of Entertainment

ORDER NO.  
ARP2893

STEREO AMPLIFIER

# A-204R

- Refer to the service manual ARP2852 for A-203/HEXJ.

THIS MANUAL IS APPLICABLE TO THE FOLLOWING MODEL(S) AND TYPE(S).

Type	Model	Power Requirement	The voltage can be converted by the following method.
	A-204R		
HEXJ	○	AC 220 - 230V	AC 240V,*
HEWZXJ	○	AC 220 - 230V	AC 240V,*
HBWXJ	○	AC 230V	AC 240V,*

\* : Alter the wiring of the Power-supply block at the primary winding of Power-transformer referring to the "Line Voltage Selection" described in Service Manual.

**PIONEER ELECTRONIC CORPORATION** 4-1, Meguro 1-Chome, Meguro-ku, Tokyo 153, Japan  
**PIONEER ELECTRONICS SERVICE INC.** PO Box 1760, Long Beach, California 90801 U.S.A.  
**PIONEER ELECTRONICS OF CANADA, INC.** 300 Allstate Parkway Markham, Ontario L3R 0P2 Canada  
**PIONEER ELECTRONIC [EUROPE] N.V.** Haven 1087 Keetberglaan 1, 9120 Melsele, Belgium  
**PIONEER ELECTRONICS AUSTRALIA PTY. LTD.** 178-184 Boundary Road, Braeaeide, Victoria 3195, Australia TEL ; [03] 580-9911

© PIONEER ELECTRONIC CORPORATION 1995

O-ZFK APR. 1995 Printed in Japan

## ● CONTRAST OF MISCELLANEOUS PARTS

**NOTES:**

- Parts marked by "NSP" are generally unavailable because they are not in our Master Spare Parts List.
- The  $\triangle$  mark found on some component parts indicates the importance of the safety factor of the part. Therefore, when replacing, be sure to use parts of identical designation.
- Parts marked by "⊙" are not always kept in stock. Their delivery time may be longer than usual or they may be unavailable.

A-204R/HEWZXJ, A-204R/HBWXJ and A-203/HEXJ have the same construction except for the following:

Mark	Symbol & Description	Part No.				Remarks
		A-203 / HEXJ	A-204R / HEXJ	A-204R / HEWZXJ	A-204R / HBWXJ	
NSP	AF assy	AWK1787	AWK7118	AWK7118	AWK7119	For front panel
	Power transformer	ATS1538	ATS7060	ATS7060	ATS7060	
$\triangle$	FUSE FU1 (T1.25A)	REK1023	.....	.....	.....	
$\triangle$	FUSE FU1 (T1.0A)	.....	REK1022	REK1022	REK1022	
$\triangle$	Power AC cord	ADG1154	ADG1154	ADG1154	ADG1156	
$\triangle$	Remote control unit (CU-A014)	.....	AXD7049	AXD7049	AXD7049	
	Filter	.....	AAK7141	AAK7141	AAK7141	
	Wire clamp	.....	AEC7022	AEC7022	AEC7022	
	Front panel (PLS)	AMB2231	AMB7194	AMB7194	AMB7194	
	Rear panel (MET)	ANC2173	ANC7234	ANC7235	ANC7190	
NSP	Radiator	ANH1464	ANH1465	ANH1465	ANH1465	
NSP	Getter (LABEL)	.....	AAX7171	AAX7171	AAX7171	
	Holder	.....	VEC1355	VEC1355	VEC1355	
	Operating instructions (English / French / German/Italian / Swedish / Spanish / Dutch / Portuguese)	ARE1302	ARE7046	.....	.....	
	Operating instructions (German)	.....	.....	ARC7069	.....	
	Operating instructions (Spanish / German)	.....	.....	.....	ARB7046	
	Packig case	AHD2672	AHD7145	AHD7145	AHD7202	
	Paper protector A	AHA1660	AHA7061	AHA7061	AHA7061	
	Paper protector B	AHA1661	AHA7062	AHA7062	AHA7071	
	Paper protector C	AHA1662	AHA7063	AHA7063	AHA7072	
	Paper protector D	.....	AHA7064	AHA7064	AHA7073	
NSP	Polyethy lene bag	.....	AHG1217	AHG1217	AHG1217	
NSP	Air cap	.....	.....	.....	AHG1087	



● SCHEMATIC AND PCB CONNECTION DIAGRAMS

A

B

C

D

E

F

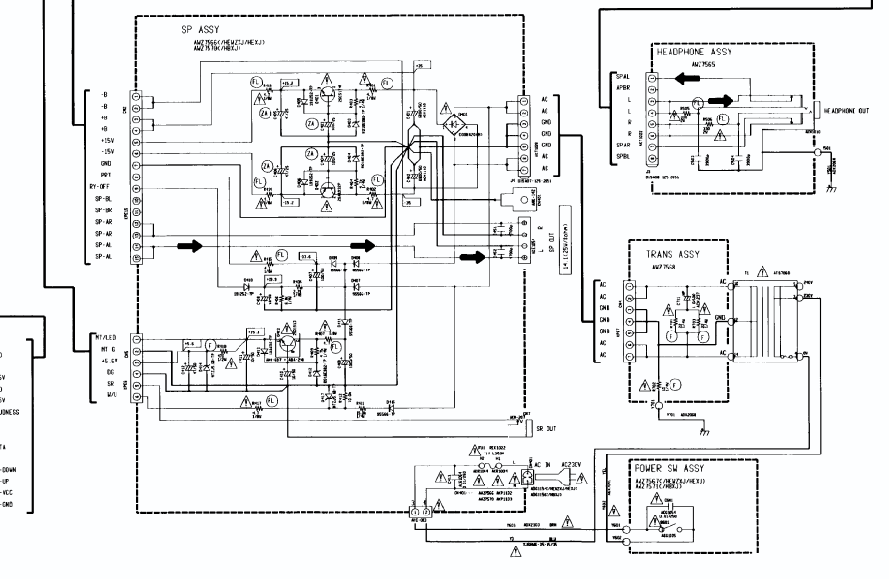
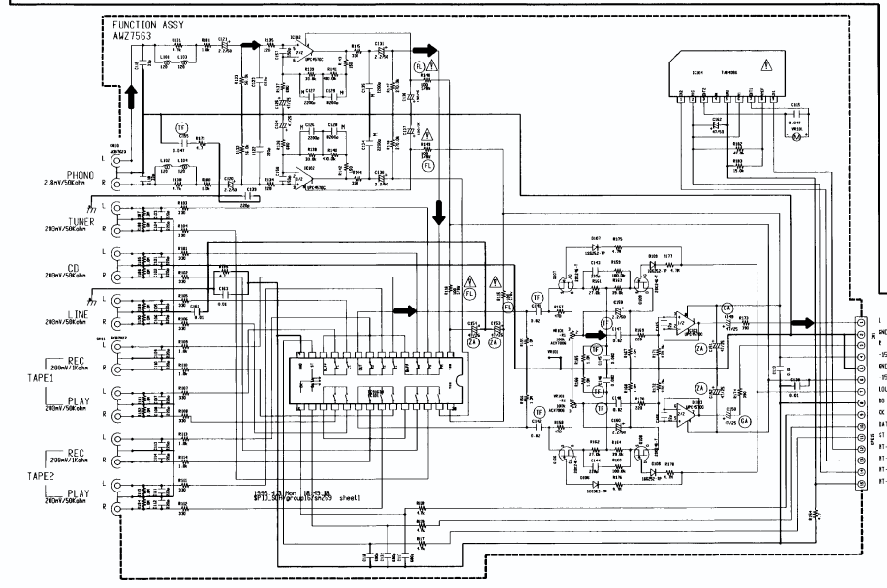
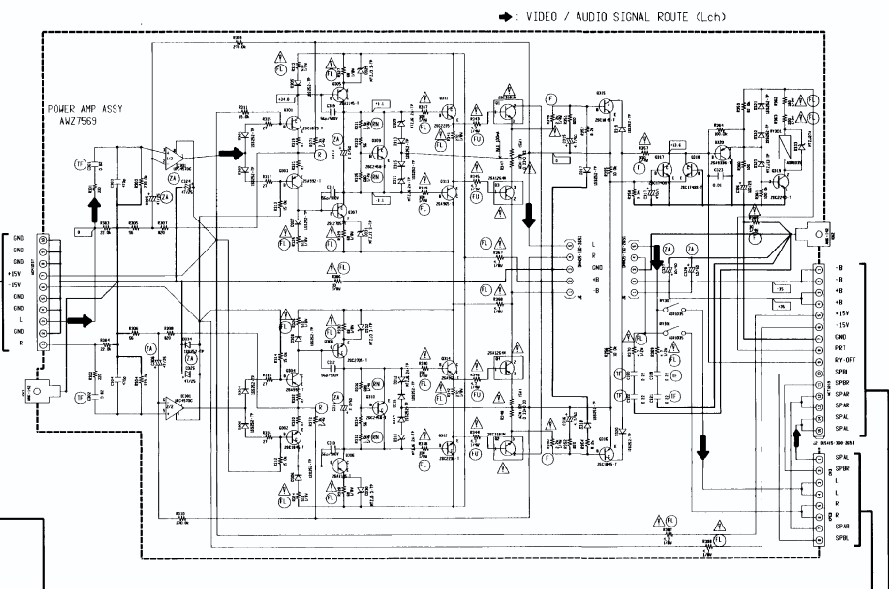
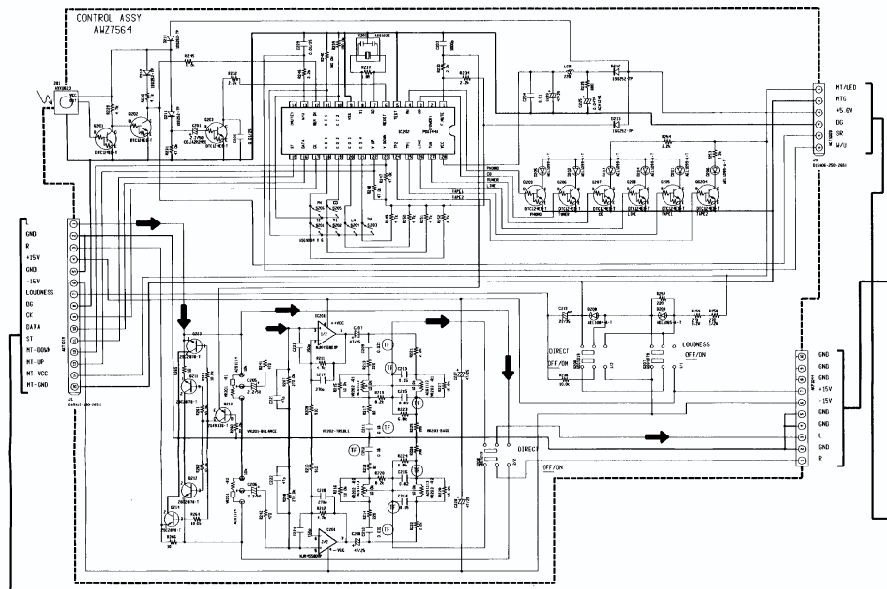

➔ VIDEO / AUDIO SIGNAL ROUTE (Lch)

NOTE FOR SCHEMATIC DIAGRAMS (Type 1A)

- When ordering service parts, be sure to refer to "PARTS LIST OF EXPLODED VIEWS" or "PCB PARTS LIST".
- Since these are basic circuits, some parts of them or the values of some components may be changed for improvement.
- RESISTORS:  
Unit: k:K, M:MQ, or Ω unless otherwise noted.  
Tolerance: (F): ±1%, (G): ±2%, (K): ±10%, (M): ±20% or ±5% unless otherwise noted.
- CAPACITORS:  
Unit: p:F or μF unless otherwise noted.  
Ratings: capacitor (μF)/voltage (V) unless otherwise noted.  
Rated voltage: 50V except for electrolytic capacitors.
- COILS:  
Unit: m:mH or μH unless otherwise noted.
- VOLTAGE AND CURRENT:  
V: Signal voltage at rated output.  
V: DC voltage (V) at no input signal unless otherwise noted.  
value in ( ) is DC voltage at rated power.  
mA: DC current at no input signal unless otherwise noted.
- OTHERS:  
⊙ or ⊛: Adjusting point.  
⊙: Measurement point.  
⚡: The ⚡ mark found on some component parts indicates the importance of the safety factor of the parts. Therefore, when replacing, be sure to use parts of identical designation.
- SCH-□ ON THE SCHEMATIC DIAGRAM:  
SCH-□ indicates the drawing number of the schematic diagram. (SCH stands for schematic diagram.)
- SWITCHES (underline indicates switch position):  
CONTROL ASSY  
S201: TAPE2  
S202: TAPE1  
S203: TUNER  
S204: LINE  
S205: CD  
S206: PHONE  
S207: PHONO  
S208: LOUDNESS OFF/ON  
S209: DIRECT OFF/ON  
POWER SW ASSY  
S801: POWERH

A

B

C

D

E

F

# Service Manual

**PIONEER®**  
The Art of Entertainment

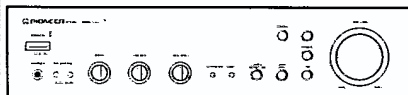

The illustration shows model A-203.

ORDER NO.  
**ARP2852**

## STEREO AMPLIFIER

# A-203

# A-103

THIS MANUAL IS APPLICABLE TO THE FOLLOWING MODEL(S) AND TYPE(S).

Type	Model		Power Requirement	The voltage can be converted by the following method.
	A-203	A-103		
HEXJ	○	○	AC220—230V	AC240V, *
HBXJ	○	○	AC240V	AC220—230V, *
HEWZXJ	○	○	AC220—230V	AC240V, *
HLXJ	○	○	AC220—230V	AC240V, *
SDXJ	○	○	AC110V/120—127V/220V/240V	With the voltage selector
YPWXJ	—	○	AC240V	—

\* : Alter the wiring of the Power-supply block at the primary winding of Power-transformer referring to the "Line Voltage Selection" described in Service Manual.

- For the following: A-203/HBXJ, HEWZXJ, HLXJ and SDXJ; A-103/HBXJ, HEWZXJ, HLXJ, SDXJ and YPWXJ, refer to page 22.

## CONTENTS

1. DISASSEMBLY .....	2
2. EXPLODED VIEWS, PACKING AND PARTS LIST ...	3
3. SCHEMATIC DIAGRAM .....	6
4. PCB CONNECTION DIAGRAMS .....	9
5. BLOCK DIAGRAM .....	17
6. PCB PARTS LIST .....	18
7. IC INFORMATION .....	21
8. FOR A-203/HBXJ, HEWZXJ, HLXJ SDXJ, A-103/HBXJ, HEWZXJ, HLXJ, SDXJ AND YPWXJ ...	22
9. PANEL FACILITIES .....	25
10. SPECIFICATIONS .....	28

**PIONEER ELECTRONIC CORPORATION** 4-1, Meguro 1-Chome, Meguro-ku, Tokyo 153, Japan  
**PIONEER ELECTRONICS SERVICE INC.** P.O. Box 1760, Long Beach, California 90801 U.S.A.  
**PIONEER ELECTRONICS OF CANADA, INC.** 300 Allstate Parkway Markham, Ontario L3R 0P2 Canada  
**PIONEER ELECTRONIC [EUROPE] N.V.** Haven 1087 Keetberglaan 1, 9120 Melsele, Belgium  
**PIONEER ELECTRONICS AUSTRALIA PTY. LTD.** 178-184 Boundary Road, Braeside, Victoria 3195, Australia TEL: [03] 580-9911  
 © **PIONEER ELECTRONIC CORPORATION 1994**

O-FFO APR. 1994 Printed in Japan

# 1. DISASSEMBLY

## ● CHECKING FOR POWER AMP ASSY

1. Remove the bonnet.
2. Remove the VOLUME knob and unscrew nut the ① (Fig. 1).
3. Unscrew the fastening screws ② of the front panel (2 upper and 5 lower screws. ).
4. Unscrew the fastening screws ③ (1 screw) and ④ (2 screws) of the RADIATOR.
5. Lift up the RADIATOR (in the direction of the arrow ⑤) approximately 5mm, and remove it from the chassis hook.
6. Remove the lower hooks ⑥ of the front panel (2 places).
7. Slowly remove the front panel together with the RADIATOR. When doing this, be careful so that the flat cable ⑦ form CN 1 does not get caught.
8. When the VOLUME knob shaft ⑨ has been distanced from the front panel, lower the fins of the RADIATOR as shown in Fig. 2 and raise the shaft.

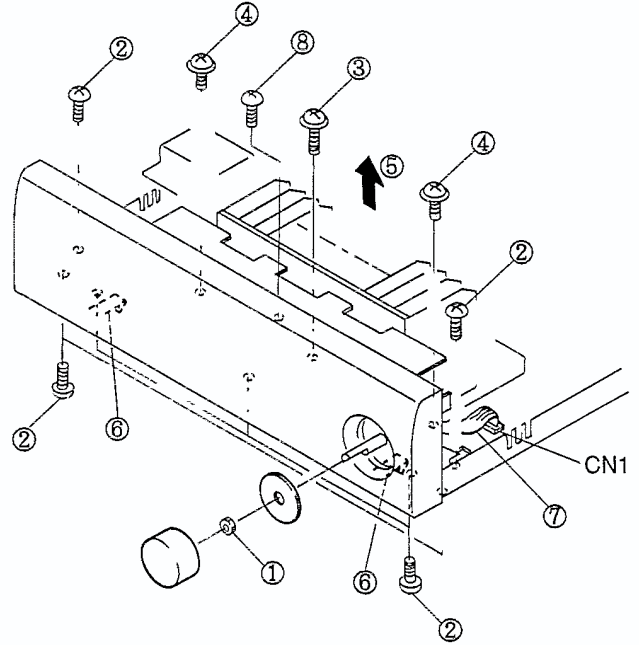

Fig. 1

## ● HOW TO REMOVE THE POWER AMP ASSY

1. Remove the fastening screw ③ of the RADIATOR (1 screw) and ④ (2 screws) and the center fastening screw ⑧ (1 screw) of the POWER AMP ASSY (Fig. 1).
2. Lift up the RADIATOR (in the direction of the arrow ⑤) approximately 5mm, and remove it from the chassis hook.
3. Pull the RADIATOR backward and remove the POWER AMP ASSY and RADIATOR together.

Note : The CONTROL ASSY of the front panel and the POWER AMP ASSY are connected only with connectors, and they can be easily removed by carrying out the above operations.

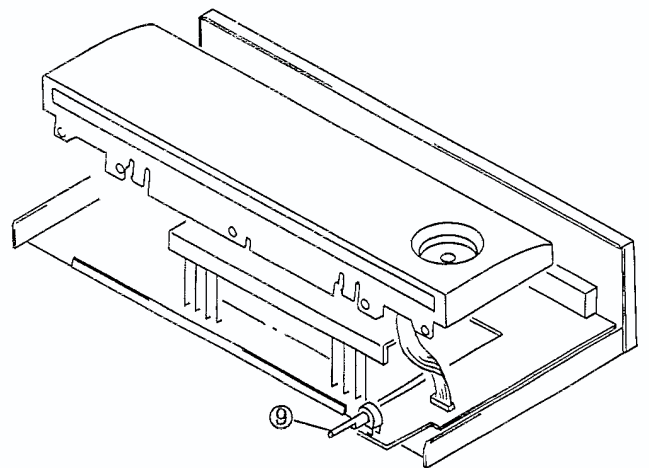
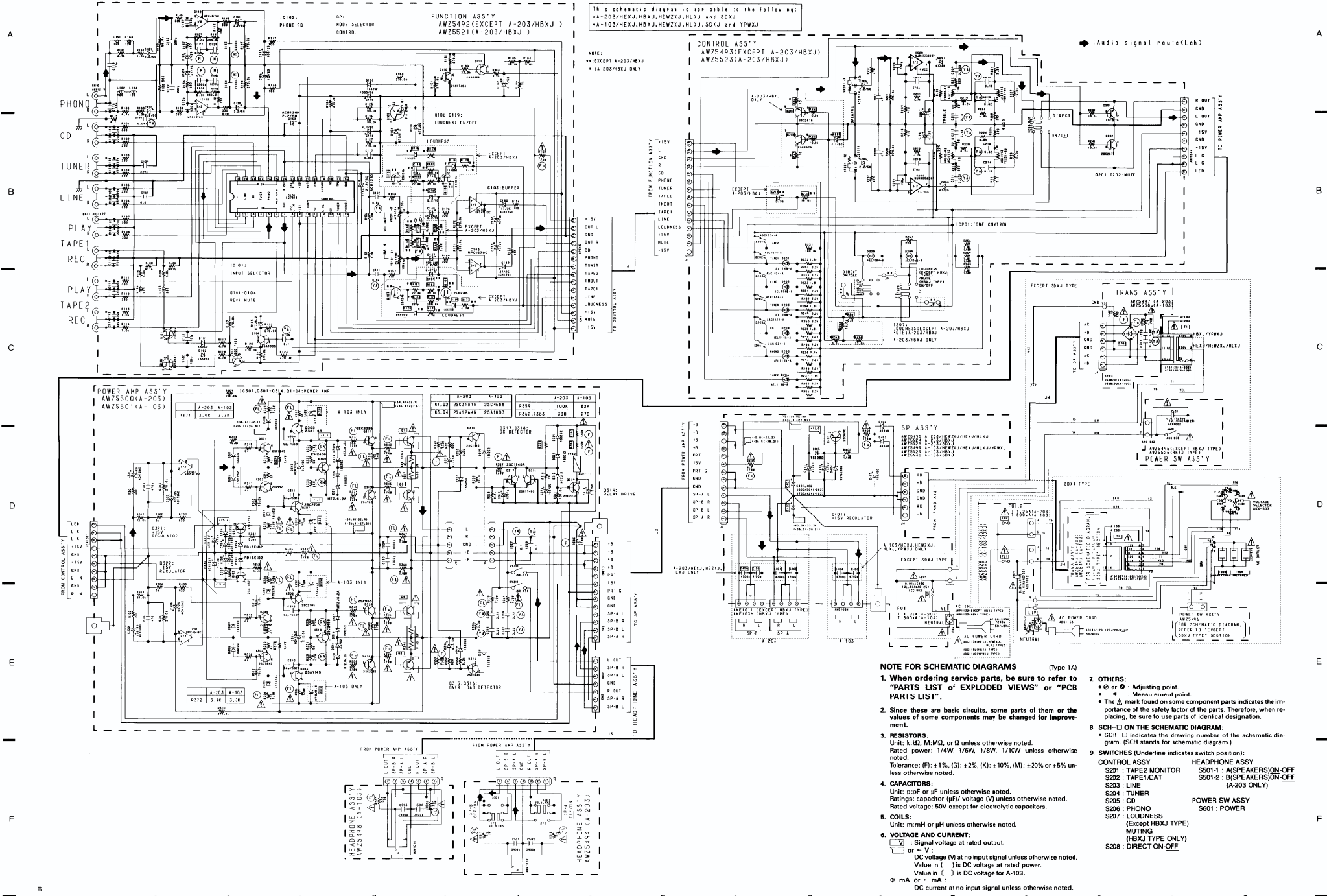

Fig.2



3. SCHEMATIC DIAGRAM



## 2. EXPLODED VIEWS, PACKING AND PARTS LIST

### NOTES:

- Parts marked by "NSP" are generally unavailable because they are not in our Master Spare Parts List.
- ▲ The  $\Delta$  mark found on some component parts indicates the importance of the safety factor of the part. Therefore, when replacing, be sure to use parts of identical designation.
- Parts marked by "●" are not always kept in stock. Their delivery time may be longer than usual or they may be unavailable.

Mark No.	Description	Parts No.	Mark No.	Description	Parts No.
$\Delta$ 1	03.04 TRANSISTOR (For A-203)	2SA1264N	38	CONTROL ASSY	AWZ5493
$\Delta$ 1	03.04 TRANSISTOR (For A-103)	2SA1803	39	HEADPHONE ASSY (For A-203)	AWZ5494
$\Delta$ 2	Q1,Q2 TRANSISTOR (For A-203)	2SC3181N	39	HEADPHONE ASSY (For A-103)	AWZ5498
$\Delta$ 2	Q1,Q2 TRANSISTOR (For A-103)	2SC4688	40	SP ASSY (For A-203)	AWZ5495
$\Delta$ 3	T1 POWER TRANSFORMER (For A-203)	ATS1538	40	SP ASSY (For A-103)	AWZ5499
$\Delta$ 3	T1 POWER TRANSFORMER (For A-103)	ATS1540	41	POWER SW ASSY	AWZ5496
4	TERMINAL SCREW	AKE-031	42	TRANS ASSY (For A-203)	AWZ5497
$\Delta$ 5	FU1 FUSE (1.25A)	REK1073	42	TRANS ASSY (For A-103)	AWZ5538
$\Delta$ 5	FU1 FUSE (400mA)	REK1021	43	POWER AMP ASSY (For A-203)	AWZ5500
6	CHASSIS MFT	ANA1278	43	POWER AMP ASSY (For A-103)	AWZ5501
7	REAR PANEL (For A-203)	ANC2173	$\Delta$ 44	AC POWER CORD	ADG1154
7	REAR PANEL (For A-103)	ANC2177	45	OPER. INSTRUCTIONS	AEE1302
8	RADIATOR (For A-203)	ANH1484	46	PAPER PROTECTOR A	AHA1660
8	RADIATOR (For A-103)	ANH1485	47	PAPER PROTECTOR B	AHA1661
9	INSULATOR	PNW1912	48	PAPER PROTECTOR C	AHA1662
10	RING(MET)	ANG1917	49	PACKING CASE (For A-203)	AHD2672
11	PCB HOLDER(MET)	ANG1918	49	PACKING CASE (For A-103)	AHD2673
12	PCB SPACER(PLS)	AEC1566	50	PACKING SHEET	AHG1212
13	PCB SPACER(PLS)	AEC1567			
14	SHEET (A-203 only)	AEE10-4			
15	BINDER	AEP-215			
16	PCB MOLD(PF)	AMR2533			
17	SCREW	ABA-298			
18	SCREW	ABA1018			
19	SCREW	ABA1027			
20	SCREW (STEEL)	ABA1082			
21	SCREW (STEEL)	ABA1095			
22	SCREW (STEEL)	ABA1193			
23	SCREW	BBT30N80FZK			
24	SCREW	BCZ30P080FZK			
25	SCREW	BPZ20P080FMC			
26	NU1	NK1091C			
27	SCREW	VPZ30P100FMC			
28	LED LENS	AAK2552			
29	NAME PLATE	PAM1608			
30	ROUND KNOB L (PLS)	AA81340			
31	ROUND KNOB S (PLS)	AA82221			
32	POWER BUTTON	AAD2539			
33	FUNCTION BUTTON	AAD2540			
34	PUSH BUTTON (PLS)	AAD4645			
35	BONNET CASE	ANE1464			
36	FRONT PANEL (For A-203)	AMB2231			
36	FRONT PANEL (For A-103)	AMB2232			
37	FUNCTION ASSY	AWZ5492			

### EXPLODED VIEWS

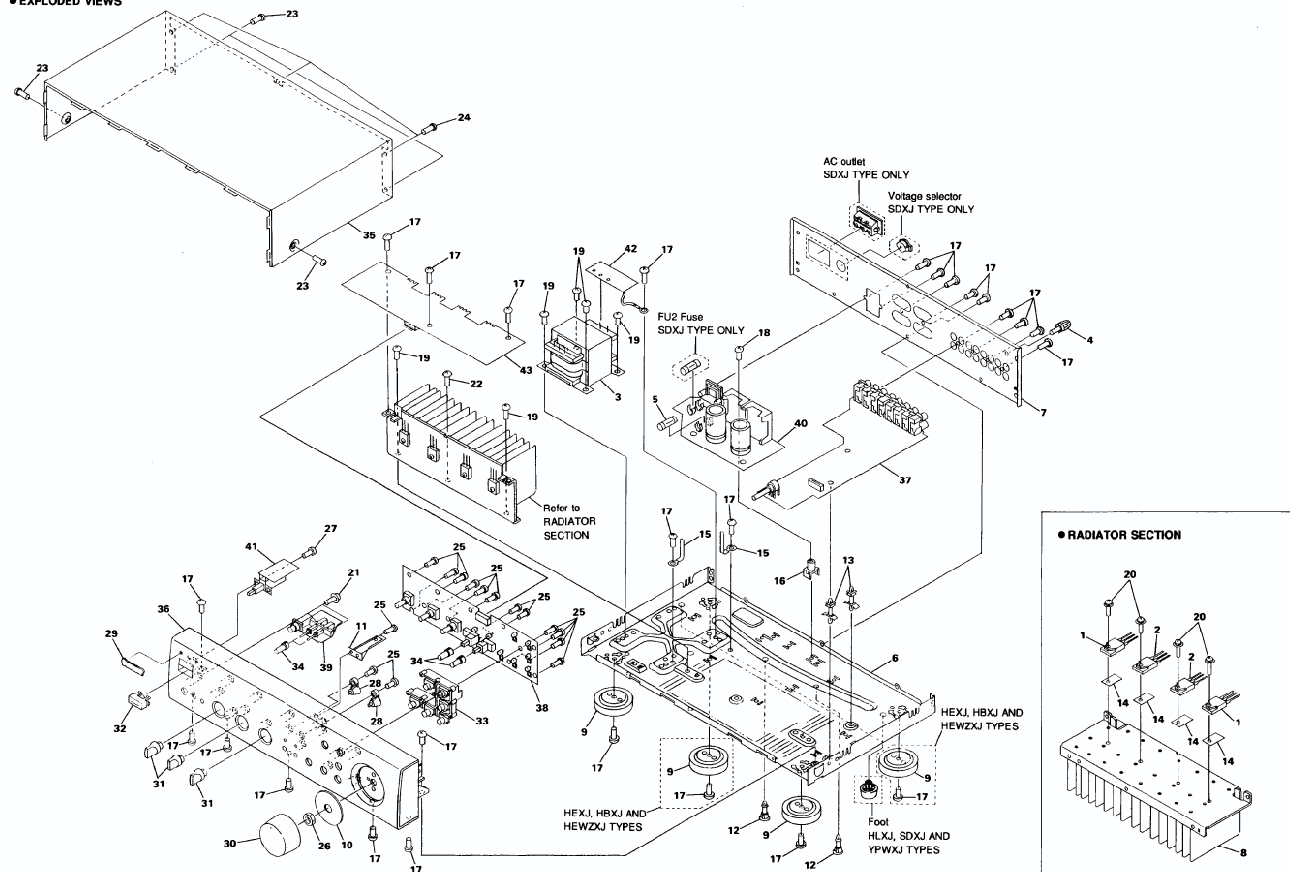

NOTE: Screws adjacent to  $\nabla$  mark on product are used for disassembly.









• This diagram is viewed from the mounted parts side.

PCB-1

A

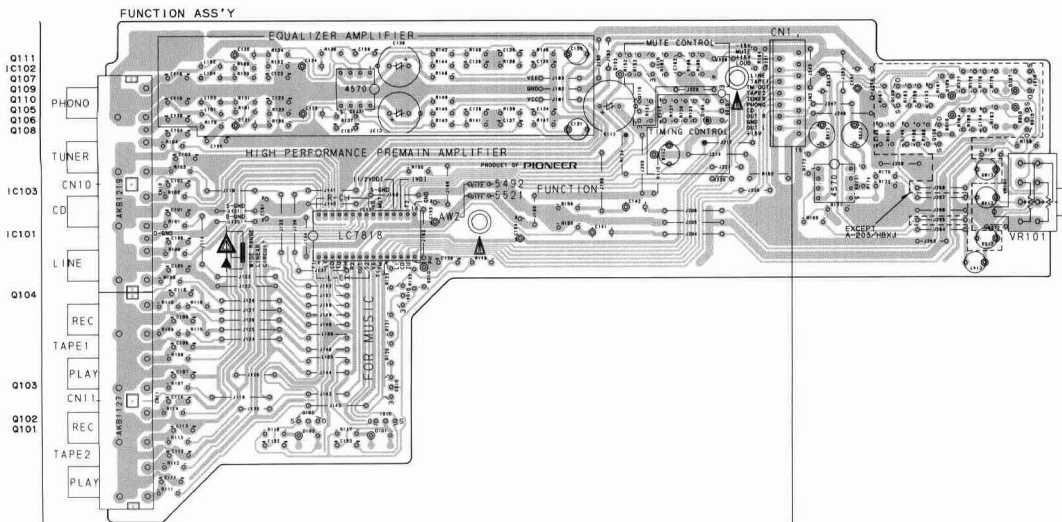

NOTE FOR PCB DIAGRAMS:

1. Part numbers in PCB diagrams match those in the schematic diagrams.
2. A comparison between the main parts of PCB and schematic diagrams is shown below.

Symbol in PCB Diagrams	Symbol in Schematic Diagrams	Part Name
 Q504	 Q504	Transistor
 D203	 D203	Diode
 C513	 C513	Capacitor (Polarized)

3. The transistor terminal marked with E or  $\ominus$  shows the emitter.
4. The diode terminal marked with  $\oplus$  or C shows cathode side.
5. The capacitor terminal marked with  $\oplus$  or L shows negative terminal.

C

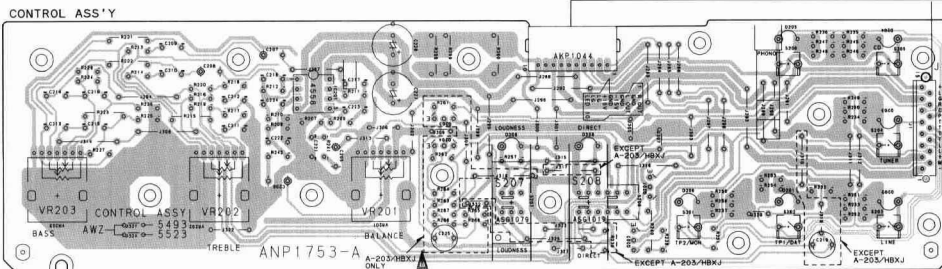

D

A

B

C

D

# 5. BLOCK DIAGRAM

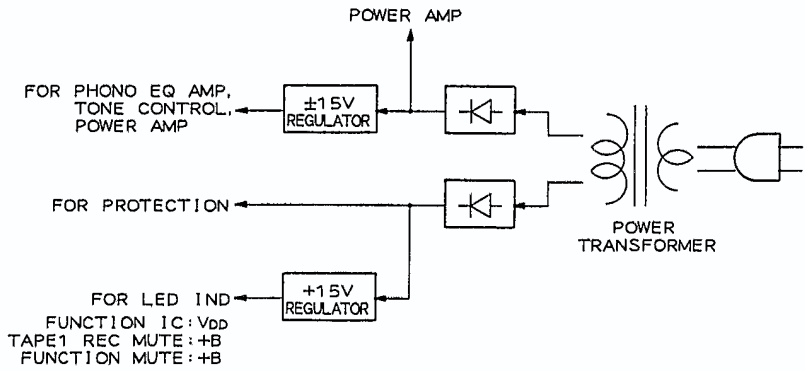
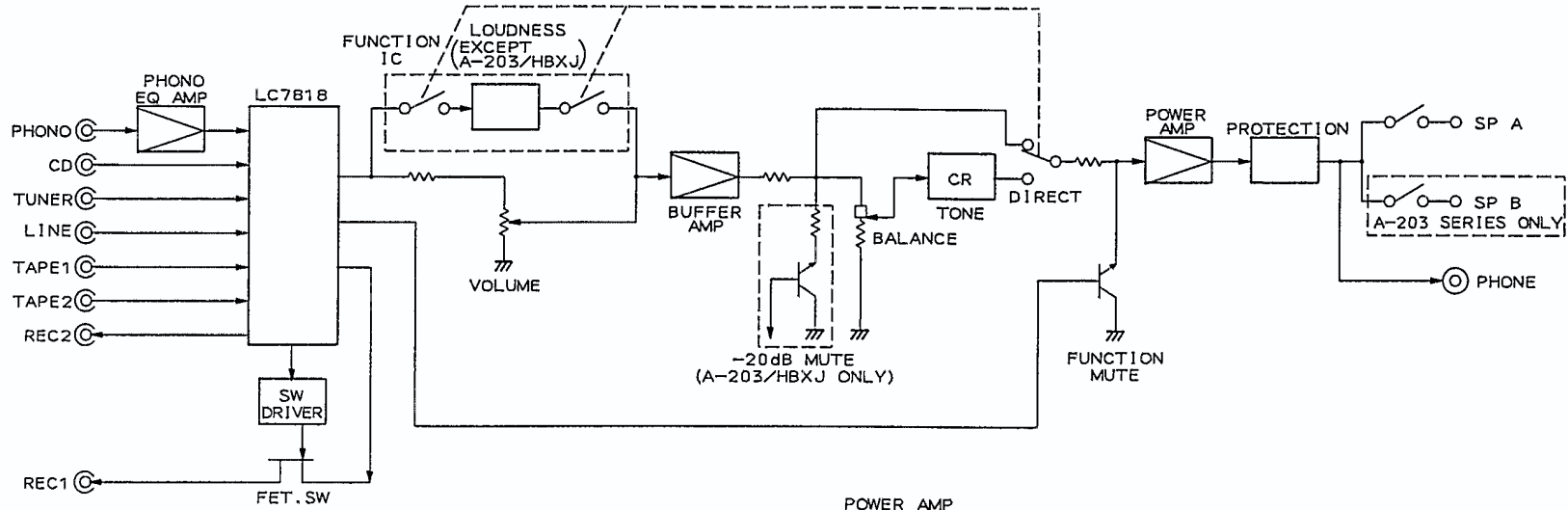

A-203, A-103

## 6. PCB PARTS LIST

**NOTES:**

- Parts marked by "NSP" are generally unavailable because they are not in our Master Spare Parts List.
- The  $\Delta$  mark found on some component parts indicates the importance of the safety factor of the part. Therefore, when replacing, be sure to use parts of identical designation.
- Parts marked by "●" are not always kept in stock. Their delivery time may be longer than usual or they may be unavailable.
- When ordering resistors, first convert resistance values into code form as shown in the following examples.

Ex.1 When there are 2 effective digits (any digit apart from 0), such as 560 ohm and 47k ohm (tolerance is shown by J = 5%, and K = 10%).

560 $\Omega$	$\rightarrow$	56 $\times 10^1$	$\rightarrow$	561	.....	RD1/8PM	<table border="1"><tr><td>5</td><td>6</td><td>1</td></tr></table> J	5	6	1
5	6	1								
47k $\Omega$	$\rightarrow$	47 $\times 10^3$	$\rightarrow$	473	.....	RD1/4PS	<table border="1"><tr><td>4</td><td>7</td><td>3</td></tr></table> J	4	7	3
4	7	3								
0.5 $\Omega$	$\rightarrow$	0R5	.....		.....	RN2H	<table border="1"><tr><td>0</td><td>R</td><td>5</td></tr></table> K	0	R	5
0	R	5								
1 $\Omega$	$\rightarrow$	010	.....		.....	RSIP	<table border="1"><tr><td>0</td><td>1</td><td>0</td></tr></table> K	0	1	0
0	1	0								

Ex.2 When there are 3 effective digits (such as in high precision metal film resistors).

5.62k $\Omega$	$\rightarrow$	562 $\times 10^1$	$\rightarrow$	5621	.....	RN1/4PC	<table border="1"><tr><td>5</td><td>6</td><td>2</td><td>1</td></tr></table> F	5	6	2	1
5	6	2	1								

Mark	No.	Description	Parts No.	Mark	Mark	No.	Description	Parts No.	Mark
------	-----	-------------	-----------	------	------	-----	-------------	-----------	------

**LIST OF ASSEMBLIES**

NSP	AF ASSY (For A-203)	FUNCTION ASSY	AWK1787			C136,C137	CEAS101M25
		CONTROL ASSY	AWZ5492			C115	CEAS102M16
		HEADPHONE ASSY	AWZ5493			C120,C121,C130,C131	CEAS2R2M50
		SP ASSY	AWZ5494			C159,C160	CEAS2R2M50
			AWZ5495			C124,C125,C151,C152	CEAS470M25
	AF ASSY (For A-103)	POWER SW ASSY	AWZ5496			C116	CEAS4R7M50
		TRANS ASSY	AWZ5497			C138	CFTYA104J50
		POWER AMP ASSY	AWZ5500			C155	CFTYA473J50
						C117	CFTYA563J50
						C145,C146	CFTYA823J50
NSP	AF ASSY (For A-103)	FUNCTION ASSY	AWK1788			C141,C142	CFTYA824J50
		CONTROL ASSY	AWZ5492			C161	CKCYF103Z50
		POWER SW ASSY	AWZ5496			C126,C127,C134,C135	CQMA222J50
		HEADPHONE ASSY	AWZ5498			C128,C129	CQMA822J50
		SP ASSY	AWZ5499				
	POWER AMP ASSY	AWZ5501					
	TRANS ASSY	AWZ5538					

**RESISTORS**

$\Delta$	R182		RFA1/4PS4R7J				
	VR101	(100k - A5 $\times$ 2)	ACT1084				
	Other Resistors		RD1/8PM <table border="1"><tr><td> </td><td> </td><td> </td><td> </td></tr></table> J				

**FUNCTION ASSY**

**SEMICONDUCTORS**

IC101	LC7818
IC102,IC103	UPC4570C
Q104,Q111	2SA933S
Q103,Q110	2SC1740S
Q101,Q102,Q106-Q109	2SK246
Q105	DTA124ES
D101-D103,D106-D109	1SS252
D110	MTZJ20
D104,D105	MTZJ8.2

**COILS AND FILTERS**

L101-L104	LAU121K
L105,L106	LAU221K

**CAPACITORS**

C147,C148,C153,C154 (2.2/50)	ACH1260
C149,C150 (47/25)	ACH1261
C132,C133	CCCSL101J50
C156,C157	CCCSL151J50
C101-C114,C122,C123,C139	CCCSL221J50
C143,C144	CCCSL221J50
C118,C119	CCCSL330J50
C162	CEANP4R7M50

**OTHERS**

CN11	(PIN JACK-8P)	AKB1127
CN10	(PIN JACK-8P)	AKB1219
CN1	CONNECTOR(15P)	KPE15

**CONTROL ASSY**

**SEMICONDUCTORS**

IC201		NJM4558DXP
Q201,Q202		2SC2878
D209	(Red)	AEL1065
D208	(Orange)	AEL1084
D201-D206	(Red)	AEL1148

**SWITCHES AND RELAYS**

S208	ASG1019
S201-S206	ASG1034
S207	ASG1079

**CAPACITORS**

C223,C224	CCCSL151J50
C217,C218	CCCSL271J50
C221,C222	CCCSL470J50
C219	CEANP220M35
C205,C206	CEAS2R2M50



Mark	No.	Description	Parts No.	Mark	Mark	No.	Description	Parts No.	Mark
	C207,C208,C227,C228 C213,C214 C211,C212 C209,C210 C215,C216		CEAS470M25 CFTYA154J50 CFTYA184J50 CFTYA333J50 CFTYA824J50			<b>TRANS ASSY</b>			
						<b>SEMICONDUCTORS</b>			
						D701 (For A-203) D701 (For A-103)		D5SB20F D3SBA20	
						<b>CAPACITORS</b>			
						C701,C702		CFTYA824J50	
						<b>RESISTORS</b>			
						△ R702		RFA1/4PS100J	
						△	Other Resistors	RD1/4PM□□□J	
						<b>POWER AMP ASSY</b>			
						<b>SEMICONDUCTORS</b>			
						IC301 Q305,Q306 Q322 Q313,Q314 Q303,Q304		UPC4570C 2SA1145 2SA1837 2SA965 2SA992	
						Q317,Q318 Q301,Q302,Q315,Q316 Q311,Q312 Q319 Q309,Q310		2SC1740S 2SC1845 2SC2235 2SC2240 2SC2458	
						Q307,Q308 Q321 D301-D308,D313-D322 D326,D327 D323		2SC2705 2SC4793 1SS252 1SS252 MTZJ13	
						D329-D332 (A-103 only) D309-D312 D324,D325		MTZJ3.3 MTZJ6.2A RD16ESB2	
						<b>SWITCHES AND RELAYS</b>			
						RY301		ASR-111	
						<b>CAPACITORS</b>			
						C301,C302,C313,C314 (2.2/50) C331,C332 (47/25) C305,C306,C324,C325 (100/25) C309-C312 C326		ACH1260 ACH1261 ACH1262 CCCSL560K500 CEAS101M25	
						C318 C317 C315,C316 C327,C328 C319-C322		CEAS2R2M50 CEAS471M6 CEAS4R7M50 CFTYA104J50 CFTYA224J50	
						C329,C330 C303,C304		CKCYB102K50 CKCYB471K50	
						<b>RESISTORS</b>			
						△ R347,R348 (0.33/5W) △ R362,R363 (For A-203) △ R362,R363 (For A-103) △ R369,R370 △ R385		ACN-139 RD1/2PMF331J RD1/2PMF271J RD1/2PMFL4R7J RD1/4PMF100J	
						△ R357 △ R349,R350 △ R337-R340 △ R341,R342 △ R367,R368		RD1/4PMF101J RD1/4PMF222J RD1/8MMF101J RD1/8MMF271J RD1/8MMF4R7J	
<b>Mark</b>	<b>No.</b>	<b>Description</b>	<b>Parts No.</b>	<b>Mark</b>					
						<b>RESISTORS</b>			
						R258-R260 VR202,VR203 (10k-20A×2) VR201 (250k-B×2)		RD1/4PM182J ACS1113 ACS1114	
						Other Resistors		RD1/8PM□□□J	
						<b>OTHERS</b>			
						SOCKET (10P)		AKP1044	
						<b>HEADPHONE ASSY</b>			
						<b>SWITCHES AND RELAYS</b>			
						S501 (A-203 only)		SUL6LXXS	
						<b>CAPACITORS</b>			
						C501,C502 (A-203 only) C503,C504 (A-103 only)		CKCYB392K50 CKCYB392K50	
						<b>RESISTORS</b>			
						△ R501,R502 (A-203 only) △ R505,R506 (A-103 only)		RS2LMF331J RS1LMF331J	
						<b>OTHERS</b>			
						JACK (Headphone) (For A-203) JACK (Headphone) (For A-103)		AKN1002 AKN1010	
						<b>SP ASSY</b>			
						<b>SEMICONDUCTORS</b>			
						Q401 D405 D404 D402,D403		2SC4793 1SS252 RD16ESB2 S5566	
						<b>CAPACITORS</b>			
						△ C409 (0.01/400) C401,C402 (6800/50) (For A-203) C401,C402 (4700/42) (For A-103) C407 C410,C411		ACG1002 ACH1105 ACH1269 CEAS101M50 CEAS470M50	
						C403,C404 C405,C406 (A-203 only)		CKCYB472K50 CKCYB472K50	
						<b>RESISTORS</b>			
						△ R401,R403		RFA1/4PS4R7J	
						Other Resistors		RD1/4PM□□□J	
						<b>OTHERS</b>			
						SCREW SPEAKER TERMINAL 8-P (For A-203) SPEAKER TERMINAL 4-P (For A-103) △ CN6 (AC INLET-1P)		ABA-298 AKE1011 AKE1054 AKP1132	
						<b>POWER SW ASSY</b>			
						<b>SWITCHES AND RELAYS</b>			
						△ S601		ASG1035	
						<b>CAPACITORS</b>			
						△ C601 (0.01/400)		ACG1002	

# A-203, A-103

Mark	No.	Description	Parts No.	Mark
△	R323-R326		RD1/8MMF511J	
△	R327-R330		RD1/8MMF680J	
	R371,R372 (For A-203)		RDR1/4PM392J	
	R371,R372 (For A-103)		RDR1/4PM332J	
△	R343-R346		RFA1/4PS4R7J	
	R331,R332		RN1/4PC1501F	
	R335,R336		RN1/4PC6800F	
	Other Resistors		RD1/8PM□□□J	
<b>OTHERS</b>				
	PLUG	(10P)	AKM1037	
	CN2	CONNECTOR(13P)	KPE13	
	CN3	CONNECTOR(7P)	KPE7	

## 7. IC INFORMATION

● The information shown in the list is basic information and may not correspond exactly to that shown in the schematic diagrams.

### ■ LC7818 (IC101) Input Selector IC

#### ● Block diagram

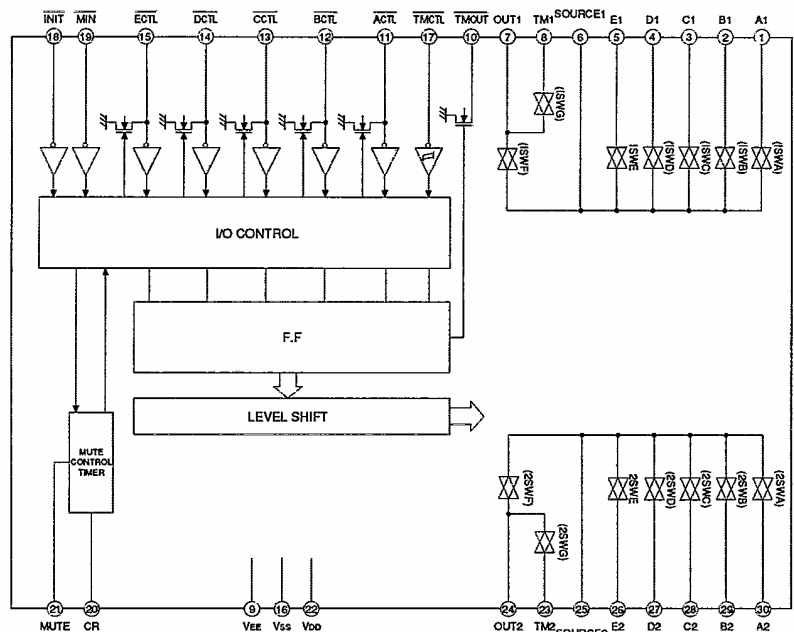

#### ● Pin Function

No.	Name	Function
1	A1	Audio signal input
2	B1	
3	C1	
4	D1	
5	E1	
6	SOURCE1	Recording output
7	OUT1	Audio signal output
8	TM1	Audio signal input
9	VEE	1. When power supply (+) is used: VSS=VEE=GND 2. When power supply (+-) is used: VSS=GND, VEE=(-)V
10	TMOUT	TM ON/OFF display LED driver output
11	ACTL	Input/output pin for analog switch control and display LED driver output
12	BCTL	
13	CCTL	
14	DCTL	
15	ECTL	
16	VSS	1. When power supply (+) is used: VSS=VEE=GND 2. When power supply (+-) is used: VSS=GND, VEE=(-)V

No.	Name	Function																						
17	TMCTL	TM control input																						
18	INIT	Mode setting input Operations According to the Combination of INIT and MIN Inputs																						
19	MIN																							
			<table border="1"> <thead> <tr> <th>INIT</th> <th>MIN</th> <th>Operations</th> </tr> </thead> <tbody> <tr> <td>H</td> <td>M</td> <td>Localization</td> </tr> <tr> <td>H</td> <td>L</td> <td>Backup</td> </tr> <tr> <td>H</td> <td>H</td> <td>Auto function</td> </tr> <tr> <td>L</td> <td>M</td> <td>Mute</td> </tr> <tr> <td>L</td> <td>L</td> <td>Initialize (Circuit A)</td> </tr> <tr> <td>L</td> <td>H</td> <td>Reset</td> </tr> </tbody> </table>	INIT	MIN	Operations	H	M	Localization	H	L	Backup	H	H	Auto function	L	M	Mute	L	L	Initialize (Circuit A)	L	H	Reset
INIT	MIN		Operations																					
H	M		Localization																					
H	L	Backup																						
H	H	Auto function																						
L	M	Mute																						
L	L	Initialize (Circuit A)																						
L	H	Reset																						
20	CR	Clock oscillation input/output Connected to C1 and R1																						
21	MUTE	Mute control output																						
22	VDD	Power supply																						
23	TM2	Audio signal input																						
24	OUT2	Audio signal output																						
25	SOURCE2	Recording output																						
26	E2	Audio signal input																						
27	D2																							
28	C2																							
29	B2																							
30	A2																							

## 8. FOR A-203/HBXJ, HEWZXJ, HLXJ, SDXJ, A-103/HBXJ, HEWZXJ, HLXJ, SDXJ AND YPWXJ

**NOTES:**

- Parts marked by "NSP" are generally unavailable because they are not in our Master Spare Parts List.
- The  $\Delta$  mark found on some component parts indicates the importance of the safety factor of the part. Therefore, when replacing, be sure to use parts of identical designation.
- Parts marked by "☉" are not always kept in stock. Their delivery time may be longer than usual or they may be unavailable.

### 8.1 CONTRAST OF MISCELLANEOUS PARTS FOR A-203/HBXJ, HEWZXJ, HLXJ AND SDXJ.

**A-203/HBXJ, HEWZXJ, HLXJ, SDXJ and A-203/HEXJ have the same construction except for the following:**

Mark	Symbol & Description	Part No.					Remarks
		A-203 HEXJ	A-203 HBXJ	A-203 HEWZXJ	A-203 HLXJ	A-203 SDXJ	
NSP	AF assembly	AWK1787	AWK1822	AWK1787	AWK1787	AWK1823	
	FUNCTION assembly	AWZ5492	AWZ5521	AWZ5492	AWZ5492	AWZ5492	
	CONTROL assembly	AWZ5493	AWZ5523	AWZ5493	AWZ5493	AWZ5493	
	SP assembly	AWZ5495	AWZ5524	AWZ5495	AWZ5495	AWZ5525	
	POWER SW assembly	AWZ5496	AWZ5526	AWZ5496	AWZ5496	AWZ5496	
$\Delta$	T1 Power transformer (AC220-230V/240V)	ATS1538	ATS1538	ATS1538	ATS1538	.....	
$\Delta$	T1 Power transformer (AC110V/120-127V/220V/240V)	.....	.....	.....	.....	ATS1539	
$\Delta$	Voltage selector (AC110V/120-127V/220V/240V)	.....	.....	.....	.....	AKX-507	Refer to page5.
$\Delta$	AC outlet	.....	.....	.....	.....	AKP-515	Refer to page5.
$\Delta$	FU2 Fuse (1.25A)	.....	.....	.....	.....	REK1023	Refer to page5.
$\Delta$	AC power cord	ADG1154	ADG1156	ADG1154	ADG1154	ADG1158	
	Rear panel	ANC2173	ANC2174	ANC2172	ANC2201	ANC2175	
	Insulator (for front/rear)	PNW1912	PNW1912	PNW1912	.....	.....	
	Insulator (for front)	.....	.....	.....	DXA1490	DXA1490	
	Foot (for rear)	.....	.....	.....	AEC1505	AEC1505	
	Front panel	AMB2231	AMB2233	AMB2231	AMB2231	AMB2231	
	Operating instructions (English/French/German/Italian/ Swedish/Spanish/Dutch/ Portuguese)	ARE1302	.....	.....	.....	.....	
	Operating instructions (English)	.....	ARB1468	.....	.....	.....	
	Operating instructions (German)	.....	.....	ARC1455	.....	.....	
	Operating instructions (English/Chinese)	.....	.....	.....	ARE1300	.....	
	Operating instructions (English/Spanish/Chinese)	.....	.....	.....	.....	ARE1301	
	Packing case	AHD2672	AHD2672	AHD2672	AHD2701	AHD2701	

**FUNCTION ASSEMBLY**

**AWZ5521 and AWZ5492 have the same construction except for the following:**

Mark	Symbol & Description	Part No.		Remarks
		AWZ5492	AWZ5521	
	D106-D109 Q106-Q109	1SS252 2SK246	..... .....	
	R159, R160 R161, R162 R163, R164 R165-R168 R175-R178	RD1/8PM104J RD1/8PM273J RD1/8PM393J RD1/8PM105J RD1/8PM475J	..... ..... ..... ..... .....	
	C143, C144 C145, C146 C159, C160	CCCSL221J50 CFTXA823J50 CEAS2R2M50	..... ..... .....	

**CONTROL ASSEMBLY**

**AWZ5523 and AWZ5493 have the same construction except for the following:**

Mark	Symbol & Description	Part No.		Remarks
		AWZ5493	AWZ5523	
	Q203, Q204	.....	2SC2878	
	R238 R261, R262 R263, R264 R265, R267 R266	RD1/8PM103J ..... ..... ..... .....	..... RD1/8PM100J RD1/8PM103J RD1/8PM332J RD1/8PM153J	
	R268	.....	RD1/8PM333J	
	C219 C225	CEANP220M35 .....	..... CEANP4R7M50	

**SP ASSEMBLY**

**AWZ5524, AWZ5525 and AWZ5495 have the same construction except for the following:**

Mark	Symbol & Description	Part No.			Remarks
		AWZ5495	AWZ5524	AWZ5525	
	C403-C406	CKCYB472K50	.....	.....	
	Speaker terminal 8-P	AKE1011	AKE1036	AKE1011	
Δ	CN6 (AC INLET-1P)	AKP1132	AKP1133	AKP1132	

**POWER SW ASSEMBLY**

**Although AWZ5526 and AWZ5496 are different in part number, they have the same service parts.**

**8.2 CONTRAST OF MISCELLANEOUS PARTS FOR A-103/HBXJ, HEWZXJ, HLXJ SDXJ AND YPWXJ.**

**A-103/HBXJ, HEWZXJ, HLXJ, SDXJ, YPWXJ and A-103/HEXJ have the same construction except for the following:**

Mark	Symbol & Description	Part No.						Remarks
		A-103 HEXJ	A-103 HBXJ	A-103 HEWZXJ	A-103 HLXJ	A-103 SDXJ	A-103 YPWXJ	
NSP	AF assembly	AWK1788	AWK1825	AWK1788	AWK1788	AWK1826	AWK1788	
	SP assembly	AWZ5499	AWZ5529	AWZ5499	AWZ5499	AWZ5530	AWZ5499	
	POWER SW assembly	AWZ5496	AWZ5526	AWZ5496	AWZ5496	AWZ5496	AWZ5496	
△	T1 Power transformer (AC220-230V/240V)	ATS1540	ATS1540	ATS1540	ATS1540	.....	ATS1540	
△	T1 Power transformer (AC110V/120-127V/220V/240V)	.....	.....	.....	.....	ATS1541	.....	
△	Voltage selector (AC110V/120-127V/220V/240V)	.....	.....	.....	.....	AKX-507	.....	Refer to page5.
△	AC outlet	.....	.....	.....	.....	AKP-515	.....	Refer to page5.
△	FU2 Fuse (800mA)	.....	.....	.....	.....	REK1021	.....	Refer to page5.
△	AC power cord	ADG1154	ADG1156	ADG1154	ADG1154	ADG1158	ADG1160	
	Rear panel	ANC2177	ANC2178	ANC2176	ANC2202	ANC2179	ANC2178	
	Insulator	PNW1912	PNW1912	PNW1912	.....	.....	.....	
	Foot	.....	.....	.....	AEC1505	AEC1505	AEC1505	
	Front panel	AMB2232	AMB2232	AMB2232	AMB2234	AMB2234	AMB2234	
	Operating instructions (English/French/German/Italian/ Swedish/Spanish/Dutch/ Portuguese)	ARE1302	.....	.....	.....	.....	.....	
	Operating instructions (English)	.....	ARB1468	.....	.....	.....	ARB1468	
	Operating instructions (German)	.....	.....	ARC1455	.....	.....	.....	
	Operating instructions (English/Chinese)	.....	.....	.....	ARE1300	.....	.....	
	Operating instructions (English/Spanish/Chinese)	.....	.....	.....	.....	ARE1301	.....	
	Packing case	AHD2673	AHD2673	AHD2673	AHD2702	AHD2702	AHD2673	

**SP ASSEMBLY**

**AWZ5529, AWZ5530 and AWZ5499 have the same construction except for the following:**

Mark	Symbol & Description	Part No.			Remarks
		AWZ5499	AWZ5529	AWZ5530	
	C403, C404	CKCYB472K50	.....	.....	
△	CN6 (AC INLET-1P)	AKP1132	AKP1133	AKP1132	

**POWER SW ASSEMBLY**

**Although AWZ5526 and AWZ5496 are different in part number, they have the same service parts.**



## 9. PANEL FACILITIES

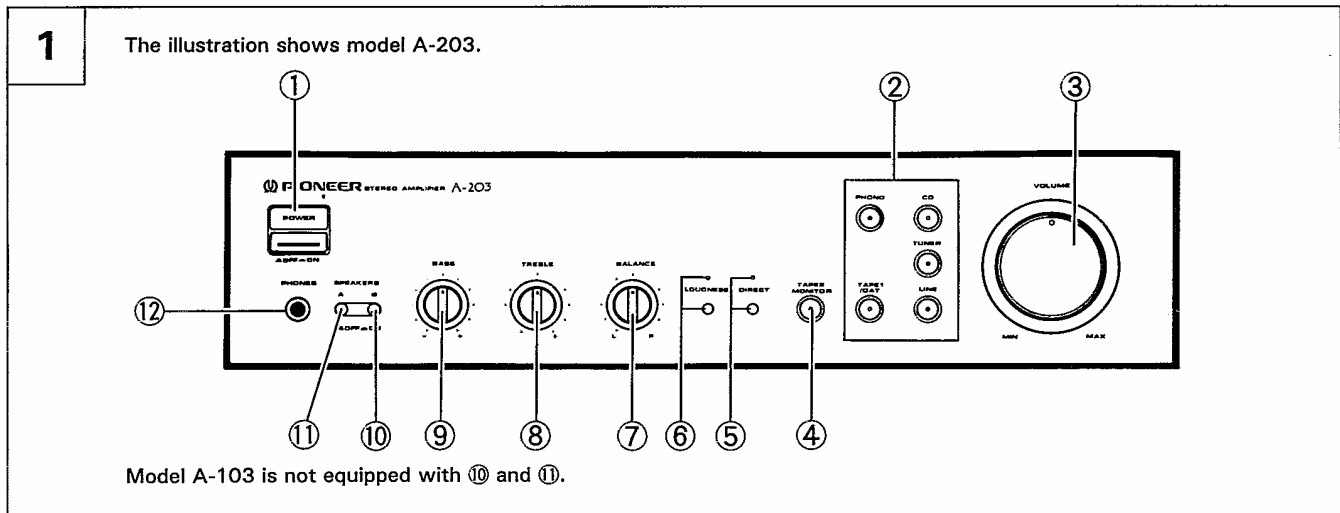

### FRONT PANEL

See Fig. **1**

#### ① POWER switch

Press to turn power to the unit ON and OFF.

#### ② Input Selector switch/indicator

Use to select the playback source.

##### PHONO:

For record playback with a turntable.

##### CD:

For compact disc playback with a CD player.

##### TUNER:

For AM or FM broadcast reception with a tuner.

##### LINE:

Set to this position when listening to the programs from a component connected to the LINE terminals.

##### TAPE 1/DAT:

For playback with a cassette deck or digital audio tape deck connected to the TAPE 1/DAT terminals.

#### ③ VOLUME control

Use to adjust the volume level.

#### ④ TAPE 2 MONITOR switch/indicator

Use when there is an adaptor component (graphic equalizer, etc.) or cassette deck connected to the TAPE 2 MONITOR terminals.

##### ON:

Indicator lights when using the adaptor component or listening to the cassette deck.

##### OFF:

Indicator goes out when not in use.

##### NOTE:

- When no connections are made to the TAPE 2 MONITOR terminals, or when they are not in use, be sure to set this switch to the OFF position. (No sound will be heard if it is set to the ON position.)
- When the TAPE 2 MONITOR indicator is on and the input selector switch is not set to TAPE 1/DAT, the signals which are input through TAPE 2 MONITOR are then output at TAPE 1/DAT REC OUT.

#### ⑤ DIRECT switch/indicator

Use this switch when you do not wish to pass the output from input terminal equipment through the various frequency adjusting circuits (BASS, TREBLE, BALANCE, LOUDNESS.)

##### ON:

The indicator lights: The signals input through the input terminals are reproduced without passing through the various frequency adjusting circuits. This results in flat, pure sound which is a more faithful reproduction of the input source.

##### OFF:

The indicator goes out: The signal passes through the various frequency adjusting circuits.

#### ⑥ MUTING button/indicator

(Only U.K. model of A-203)

Use to temporarily cut sound volume.

##### ON: (Red illumination)

The indicator lights. The sound volume will be reduced -20dB.

##### OFF:

The indicator goes off. The sound will return to its previous volume.

#### ⑥ LOUDNESS switch/indicator

(Except U.K. model of A-203)

Use when listening at low volume levels.

##### ON:

The indicator lights: Boosts low and high frequencies to give added punch to playback even at low volume levels.

##### OFF:

The indicator goes off: Should normally be left in this position.

##### NOTE:

This control does not operate when the DIRECT switch is in the ON position.

#### ⑦ BALANCE control

Should normally be left in the center position. Adjust the balance if the sound is louder from one of the speakers. If the right side is louder, turn toward the L (left) position and if the left side is louder, turn toward the R (right) position.

##### NOTE:

This control does not operate when the DIRECT switch is in the ON position.

### ⑧ TREBLE tone control

Use to adjust the high-frequency tone. The center position is the flat (normal) position. When turned to the right, high-frequency tone is emphasized; when turned to the left, high-frequency tone is de-emphasized.

**NOTE:**

*This control does not operate when the DIRECT switch is in the ON position.*

### ⑨ BASS tone control

Use to adjust the low-frequency tone. The center position is the flat (normal) position. When turned to the right, low-frequency tone is emphasized; when turned to the left, low-frequency tone is de-emphasized.

**NOTE:**

*This control does not operate when the DIRECT switch is in the ON position.*

### ⑩ SPEAKERS B selector switch (A-203 only)

Use this switch to listen to the speaker system connected to the SPEAKERS B terminals.

**ON (■):**

Depressed position: Sound is heard from the speaker system.

**OFF (■):**

Released position: No sound is heard from the speaker system.

Set to this position when listening with headphones

### ⑪ SPEAKERS A selector switch (A-203 only)

Use this switch to listen to the speaker system connected to the SPEAKERS A terminals.

**ON (■):**

Depressed position: Sound is heard from the speaker system.

**OFF (■):**

Released position: No sound is heard from the speaker system.

Set to this position when listening with headphones.

### ⑫ PHONES jack

When using headphones, insert the plug into this jack.

With model A-103 the output to the speakers is cut automatically when connecting headphones.

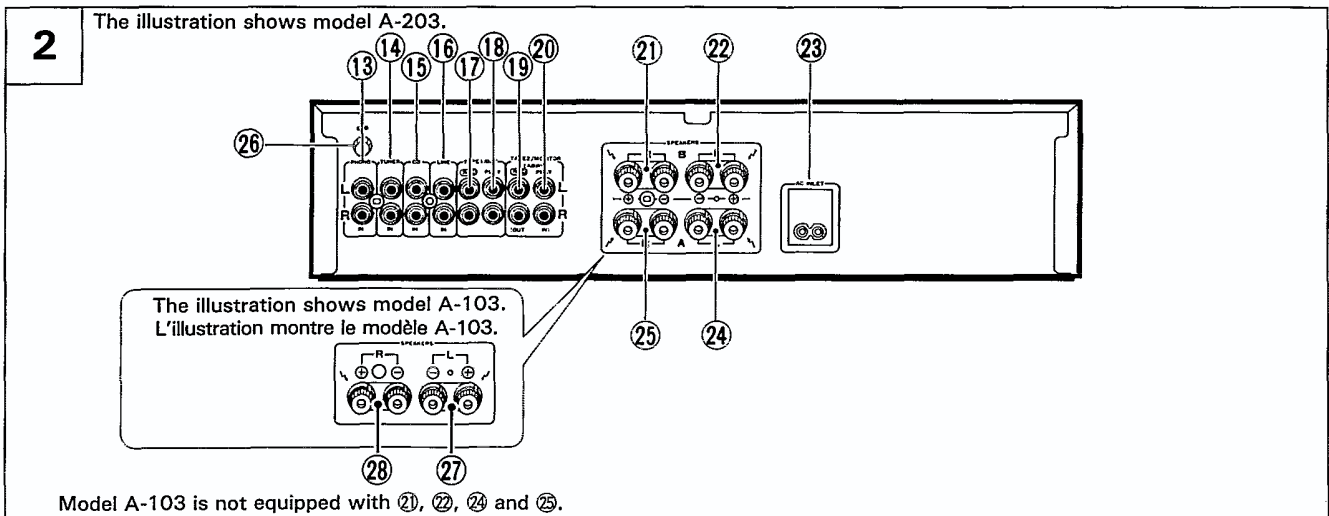

**REAR PANEL**

See Fig. **2**

- ⑬ PHONO terminals
- ⑭ TUNER terminals
- ⑮ CD terminals
- ⑯ LINE terminals
- ⑰ TAPE 1/DAT REC terminals
- ⑱ TAPE 1/DAT PLAY terminals
- ⑲ TAPE 2/MONITOR (ADPT) REC (OUT) terminals
- ⑳ TAPE 2/MONITOR (ADPT) PLAY (IN) terminals
- ㉑ SPEAKERS B terminals (right channel) (A-203 only)
- ㉒ SPEAKERS B terminals (left channel) (A-203 only)
- ㉓ AC INLET jack  
Connect power cord to here and an AC wall socket, or the AC outlet of an audio timer.  
If you are going to be away from home for a long period of time, disconnect the unit from the wall socket.
- ㉔ SPEAKERS A terminals (left channel) (A-203 only)
- ㉕ SPEAKERS A terminals (right channel) (A-203 only)
- ㉖ GND (Turntable ground) terminal
- ㉗ SPEAKERS terminals (left channel) (A-103 only)
- ㉘ SPEAKERS terminals (right channel) (A-103 only)

## 10. SPECIFICATIONS

### [A-203]

#### Amplifier Section

Continuous power output (both channels driven at 20 Hz to 20 kHz)**	
T.H.D. 0.07 %, 8 Ω	35 W + 35 W*
T.H.D. 0.1 %, 4 Ω	40 W + 40 W*
DIN Continuous power output (both channels driven at 1 kHz)	
T.H.D. 1.0 %, 8 Ω	45 W + 45 W
T.H.D. 1.0 %, 4 Ω	55 W + 55 W
Dynamic power output (E.I.A. test signal)	
4 Ω	66 W
Total harmonic distortion**	
20 Hz to 20 kHz, 17,5 W, 8 Ω	0.05 %*
• Above specifications are for when power supply is 230 V.	
Input sensitivity/impedance	
PHONO (MM)	2.8 mV/50 kΩ
CD, TUNER, LINE, TAPE 1/DAT, TAPE 2 MONITOR	200 mV/50 kΩ
PHONO overload level	
1 kHz, T.H.D. 0.1 % (MM)	150 mV
Output level/impedance	
TAPE REC, ADPT OUT	200 mV/1 kΩ
Frequency response	
PHONO (MM)	20 Hz to 20 kHz ±0.5 dB
CD, TUNER, LINE, TAPE 1/DAT, TAPE 2 MONITOR,	5 Hz to 100 kHz±0.5 dB*
Tone control	
BASS	± 8 dB (100 Hz)
TREBLE	± 8 dB (10 kHz)
Loudness contour (volume control set at -30 dB position)	
Australian model only	
	+5 dB (100 Hz)/+3 dB (10 kHz)
Signal-to-Noise ratio (IHF short circuit, A network)	
PHONO (MM, 5 mV input)	82 dB*
CD, TUNER, LINE, TAPE 1/DAT, TAPE 2 MONITOR	105 dB*
Signal-to-Noise ratio (DIN, continuous power/50 mW)	
PHONO (MM)	68 dB/64 dB*
CD, TUNER, LINE, TAPE 1/DAT, TAPE 2 MONITOR	85 dB/67 dB*

#### Power Supply/Miscellaneous

Power requirements	AC 220 - 230 Volts, 50/60 Hz
Power consumption	330 W
Dimensions (including knobs and other protruding parts)	
	420 (W) × 312 (D) × 110 (H) mm
Weight (without package)	5.2 kg

#### Accessories

Operating instructions	1
------------------------	---

#### NOTE:

Specifications and design subject to possible modification without notice, due to improvements.

\* Measured with the DIRECT switch set to ON.

\*\* Measured by Audio Spectrum Analyzer.

### [A-103]

#### Amplifier Section

Continuous power output (both channels driven at 20 Hz to 20 kHz)**	
T.H.D. 0.1 %, 8 Ω	25 W + 25 W*
DIN Continuous power output (both channels driven at 1 kHz)	
T.H.D. 1.0 %, 8 Ω	30 W + 30 W
Total harmonic distortion**	
20 Hz to 20 kHz, 12,5 W, 8 Ω	0.05 %*
• Above specifications are for when power supply is 230 V.	
Input sensitivity/impedance	
PHONO (MM)	2.8 mV/50 kΩ
CD, TUNER, LINE, TAPE 1/DAT, TAPE 2 MONITOR	200 mV/50 kΩ
PHONO overload level	
1 kHz, T.H.D. 0.1 % (MM)	150 mV
Output level/impedance	
TAPE REC, ADPT OUT	200 mV/1 kΩ
Frequency response	
PHONO (MM)	20 Hz to 20 kHz ±0.5 dB
CD, TUNER, LINE, TAPE 1/DAT, TAPE 2 MONITOR,	5 Hz to 100 kHz±0.5 dB*
Tone control	
BASS	± 8 dB (100 Hz)
TREBLE	± 8 dB (10 kHz)
Loudness contour (volume control set at -30 dB position)	
	+5 dB (100 Hz)/+3 dB (10 kHz)
Signal-to-Noise ratio (IHF short circuit, A network)	
PHONO (MM, 5 mV input)	82 dB*
CD, TUNER, LINE, TAPE 1/DAT, TAPE 2 MONITOR	105 dB*
Signal-to-Noise ratio (DIN, continuous power/50 mW)	
PHONO (MM)	68 dB/64 dB*
CD, TUNER, LINE, TAPE 1/DAT, TAPE 2 MONITOR	85 dB/67 dB*

#### Power Supply/Miscellaneous

Power requirements	AC 220 - 230 Volts, 50/60 Hz
Power consumption	210 W
Dimensions (including knobs and other protruding parts)	
	420 (W) × 312 (D) × 110 (H) mm
Weight (without package)	4,2 kg

#### Accessories

Operating instructions	1
------------------------	---

#### NOTE:

Specifications and design subject to possible modification without notice, due to improvements.

\* Measured with the DIRECT switch set to ON.

\*\* Measured by Audio Spectrum Analyzer.