

Service Manual

 **PIONEER**
The Art of Entertainment

ORDER NO.
RRV 1586

STEREO AMPLIFIER **A-205** **A-105**

● Refer to the service manual ARP2852 for A-203/HEXJ.

THIS MANUAL IS APPLICABLE TO THE FOLLOWING MODEL(S) AND TYPE(S).

Type	Model		Power Requirement	The voltage can be converted by the following method.
	A-205	A-105		
SDXJ	○	○	AC100V/120 - 127V/220V/240V	With the voltage selector
HLXJ	○	○	AC220 - 230V	AC240V, *
HVXJ	-	○	AC230V	AC220 - 230V, *
HYXJ/EW	-	○	AC220 - 230V	AC240V, *
HYXJ/GR	-	○	AC220 - 230V	AC240V, *

* : Alter the wiring of the Power-supply block at the primary winding of Power-transformer referring to the "Line Voltage Selection" described in Service Manual.

PIONEER ELECTRONIC CORPORATION 4-1, Meguro 1-Chome, Meguro-ku, Tokyo 153, Japan
PIONEER ELECTRONICS SERVICE, INC. P.O.Box 1760, Long Beach, CA 90801-1760, U.S.A.
PIONEER ELECTRONIC (EUROPE) N.V. Haven 1087, Keetberglaan 1, 9120 Melsele, Belgium
PIONEER ELECTRONICS ASIACENTRE PTE. LTD. 501 Orchard Road, #10-00 Lane Crawford Place, Singapore 0923

© PIONEER ELECTRONIC CORPORATION 1996

T-FZK APR. 1996 Printed in Japan

A-205, A-105

● CONTRAST OF MISCELLANEOUS PARTS

NOTES:

- Parts marked by "NSP" are generally unavailable because they are not in our Master Spare Parts List.
- The Δ mark found on some component parts indicates the importance of the safety factor of the part. Therefore, when replacing, be sure to use parts of identical designation.
- Parts marked by "●" are not always kept in stock. Their delivery time may be longer than usual or they may be unavailable.

CONTRAST OF A-205/SDXJ, HLXJ AND A-203/HEXJ

A-205/SDXJ, HLXJ and A-203/HEXJ have the same construction except for the following:

Mark	Symbol & Description	Part No.			Remarks
		A-203/HEXJ	A-205/SDXJ	A-205/HLXJ	
NSP	AF assembly	AWK1787	AWK1823	AWK1787	
	SP assembly	AWZ5495	AWZ5525	AWZ5495	
Δ	T1 Power transformer (AC220 - 230V/240V)	ATS1538	Not used	ATS1538	
Δ	T1 Power transformer (AC110V/120 - 127V/220V/240V)	Not used	ATS1539	Not used	
Δ	Voltage selector (AC110V/120 - 127V/220V/240V)	Not used	AKX - 507	Not used	*
Δ	AC outlet	Not used	AKP - 515	Not used	*
Δ	FU2 Fuse (T1.25A)	Not used	REK1023	Not used	*
Δ	AC power cord	ADG1154	ADG1158	ADG1154	
	Rear panel	ANC2173	ANC7414	ANC7415	
	Insulator (for front/rear)	PNW1912	Not used	Not used	
	Insulator (for front)	Not used	DXA1490	DXA1490	
	Foot (for rear)	Not used	AEC1505	AEC1505	
	Front panel	AMB2231	AMB7358	AMB7358	
	Operating instructions (English/French/German/Italian/ Swedish/Spanish/Dutch/Portuguese)	AEC1302	Not used	Not used	
	Operating instructions (English/Spanish/Chinese)	Not used	ARE7074	ARE7074	
	Packing case	AHD2672	AHD7293	AHD7293	
	Sheet	AEE1014	AEE7010	AEE7010	
	Paper protector A	AHA1660	AHA7061	AHA7061	
	Paper protector B	AHA1661	AHA7062	AHA7062	
	Paper protector C	AHA1662	AHA7063	AHA7063	
	Paper protector D	Not used	AHA7064	AHA7064	For packing
	Caution 220V label	Not used	ARR1003	Not used	For accessory

NOTE*: Refer to pages 5 in the service manual ARP2852.

SP ASSEMBLY

AWZ5525 and AWZ5495 have the same construction except for the following:

Mark	Symbol & Description	Part No.		Remarks
		AWZ5495	AWZ5525	
Δ	C403 - C406 C409	CKCYB472K50 ACG7020 (0.01 μ F/250V)	Not used ACG1002 (0.01 μ F/400V)	

A-205, A-105

CONTRAST OF A-105/SDXJ, HLXJ, HVXJ, HYXJ/EW, HYXJ/GR AND A-103/HEXJ

A-105/SDXJ, HLXJ, HVXJ, HYXJ/EW, HYXJ/GR AND A-103/HEXJ have the same construction except for the following:

Mark	Symbol & Description	Part No.						Remarks
		A-103 HEXJ	A-105 SDXJ	A-105 HLXJ	A-105 HVXJ	A-105 HYXJ/EW	A-105 HYXJ/GR	
NSP	AF assembly	AWK1788	AWK1826	AWK1788	AWK1825	AWK1788	AWK1788	
	SP assembly	AWZ5499	AWZ5530	AWZ5499	AWZ5529	AWZ5499	AWZ5499	
△	POWER SW assembly	AWZ5496	AWZ5496	AWZ5496	AWZ5526	AWZ5496	AWZ5496	
△	T1 Power transformer (AC220 – 230V/240V)	ATS1540	Not used	ATS1540	ATS1540	ATS1540	ATS1540	
△	T1 Power transformer (AC110V/120 – 127V/220V/240V)	Not used	ATS1541	Not used	Not used	Not used	Not used	
△	Voltage selector (AC110V/120 – 127V/220V/240V)	Not used	AKX – 507	Not used	Not used	Not used	Not used	*
△	AC outlet	Not used	AKP – 515	Not used	Not used	Not used	Not used	*
△	FU2 Fuse (T800mA)	Not used	REK1021	Not used	Not used	Not used	Not used	*
△	AC power cord	ADG1154	ADG1158	ADG1154	ADG1156	ADG1154	ADG1154	
△	Fuse (T5A)(With in AC plug)	Not used	Not used	Not used	AEK1046	Not used	Not used	
	Rear panel	ANC2177	ANC7418	ANC7417	ANC7419	ANC7416	ANC7416	
	Insulator	PNW1912	Not used	Not used	PNW1912	PNW1912	PNW1912	
	Foot	Not used	AEC1505	AEC1505	Not used	Not used	Not used	
	Front panel	AMB2232	AMB7360	AMB7360	AMB7359	AMB7359	AMB7359	
	Operating instructions (English/French/German/Italian/ Swedish/Spanish/Dutch/Portuguese)	AEC1302	Not used	Not used	Not used	ARE7073	Not used	
	Operating instructions (English)	Not used	Not used	Not used	ARB7075	Not used	Not used	
	Operating instructions (German)	Not used	Not used	Not used	Not used	Not used	ARC7118	
	Operating instructions (English/Spanish/Chinese)	Not used	ARE7074	ARE7074	Not used	Not used	Not used	
	Packing case	AHD2673	AHD7295	AHD7295	AHD7312	AHD7294	AHD7294	
	Paper protector A	AHA1660	AHA7061	AHA7061	AHA7061	AHA7061	AHA7061	
	Paper protector B	AHA1661	AHA7062	AHA7062	AHA7071	AHA7062	AHA7062	
	Paper protector C	AHA1662	AHA7063	AHA7063	AHA7072	AHA7063	AHA7063	
	Paper protector D	Not used	AHA7064	AHA7064	AHA7073	AHA7064	AHA7064	For packing
NSP	Air cap	Not used	Not used	Not used	AHG1087	Not used	Not used	For packing
	Caution 220V label	Not used	ARR1003	Not used	Not used	Not used	Not used	For accessory

NOTE*: Refer to page5 in the service manual ARP2852.

SP ASSEMBLY

AWZ5529, AWZ5530 and AWZ5499 have the same construction except for the following:

Mark	Symbol & Description	Part No.			Remarks
		AWZ5499	AWZ5529	AWZ5530	
△	C403, C404	CKCYB472K50	CKCYB472K50	Not used	
△	C409	ACG7020 (0.01μF/250V)	ACG7020 (0.01μF/250V)	ACG1002 (0.01μF/400V)	
	CN6 (AC INLET – 1P)	AKP1132	AKP1133	AKP1132	

POWER SW ASSEMBLY

Although AWZ5526 and AWZ5496 are different in part number, they have the same service parts.

Service Manual

PIONEER®
The Art of Entertainment

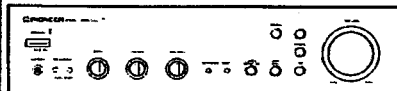

The illustration shows model A-203.

ORDER NO.
ARP2852

STEREO AMPLIFIER

A-203

A-103

THIS MANUAL IS APPLICABLE TO THE FOLLOWING MODEL(S) AND TYPE(S).

Type	Model		Power Requirement	The voltage can be converted by the following method.
	A-203	A-103		
HEXJ	○	○	AC220—230V	AC240V, *
HBXJ	○	○	AC240V	AC220—230V, * . . .
HEWZXJ	○	○	AC220—230V	AC240V, *
HLXJ	○	○	AC220—230V	AC240V, *
SDXJ	○	○	AC110V/120—127V/220V/240V	With the voltage selector
YPWXJ	—	○	AC240V	—

* : Alter the wiring of the Power-supply block at the primary winding of Power-transformer referring to the "Line Voltage Selection" described in Service Manual.

- For the following: A-203/HBXJ, HEWZXJ, HLXJ and SDXJ; A-103/HBXJ, HEWZXJ, HLXJ, SDXJ and YPWXJ, refer to page 22.

CONTENTS

1. DISASSEMBLY	2
2. EXPLODED VIEWS, PACKING AND PARTS LIST ...	3
3. SCHEMATIC DIAGRAM	6
4. PCB CONNECTION DIAGRAMS	9
5. BLOCK DIAGRAM	17
6. PCB PARTS LIST	18
7. IC INFORMATION	21
8. FOR A-203/HBXJ, HEWZXJ, HLXJ SDXJ, A-103/HBXJ, HEWZXJ, HLXJ, SDXJ AND YPWXJ ...	22
9. PANEL FACILITIES	25
10. SPECIFICATIONS	28

PIONEER ELECTRONIC CORPORATION 4-1, Meguro 1-Chome, Meguro-ku, Tokyo 153, Japan
PIONEER ELECTRONICS SERVICE INC. P.O. Box 1760, Long Beach, California 90801 U.S.A.
PIONEER ELECTRONICS OF CANADA, INC. 300 Allstate Parkway Markham, Ontario L3R 0P2 Canada
PIONEER ELECTRONIC [EUROPE] N.V. Haven 1087 Keetberglaan 1, 9120 Melsele, Belgium
PIONEER ELECTRONICS AUSTRALIA PTY. LTD. 178-184 Boundary Road, Braeside, Victoria 3195, Australia TEL: [03] 580-9911
 © **PIONEER ELECTRONIC CORPORATION 1994**

O-FFO APR. 1994 Printed in Japan

1. DISASSEMBLY

● CHECKING FOR POWER AMP ASSY

1. Remove the bonnet.
2. Remove the VOLUME knob and unscrew nut the ① (Fig. 1).
3. Unscrew the fastening screws ② of the front panel (2 upper and 5 lower screws.).
4. Unscrew the fastening screws ③ (1 screw) and ④ (2 screws) of the RADIATOR.
5. Lift up the RADIATOR (in the direction of the arrow ⑤) approximately 5mm, and remove it from the chassis hook.
6. Remove the lower hooks ⑥ of the front panel (2 places).
7. Slowly remove the front panel together with the RADIATOR. When doing this, be careful so that the flat cable ⑦ form CN 1 does not get caught.
8. When the VOLUME knob shaft ⑨ has been distanced from the front panel, lower the fins of the RADIATOR as shown in Fig. 2 and raise the shaft.

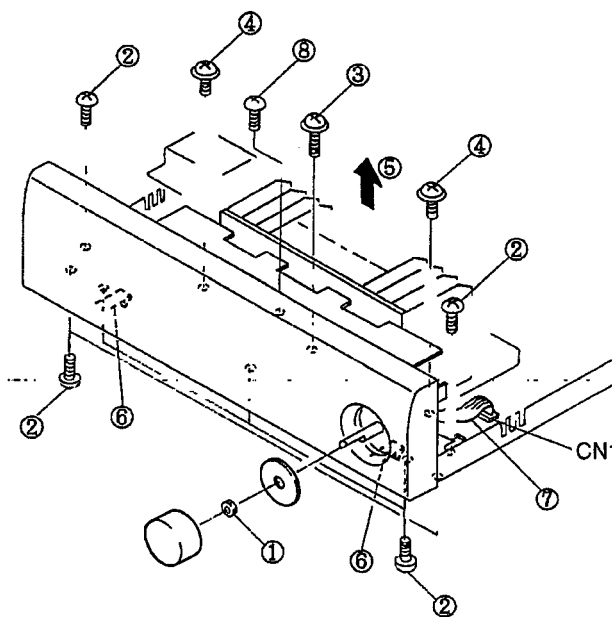

Fig. 1

● HOW TO REMOVE THE POWER AMP ASSY

1. Remove the fastening screw ③ of the RADIATOR (1 screw) and ④ (2 screws) and the center fastening screw ⑥ (1 screw) of the POWER AMP ASSY (Fig. 1).
2. Lift up the RADIATOR (in the direction of the arrow ⑤) approximately 5mm, and remove it from the chassis hook.
3. Pull the RADIATOR backward and remove the POWER AMP ASSY and RADIATOR together.

Note : The CONTROL ASSY of the front panel and the POWER AMP ASSY are connected only with connectors, and they can be easily removed by carrying out the above operations.

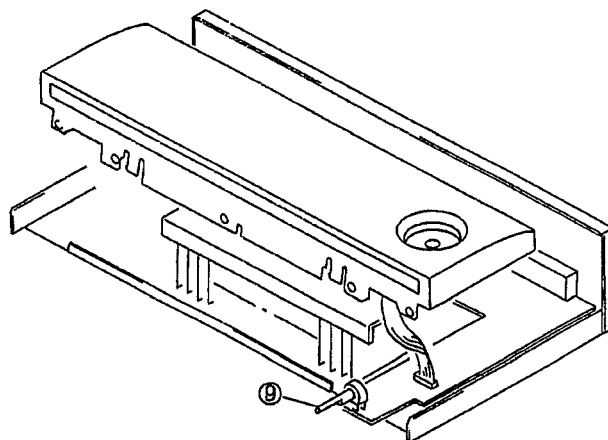

Fig.2

2. EXPLODED VIEWS, PACKING AND PARTS LIST

NOTES:

- Parts marked by "NSP" are generally unavailable because they are not in our Master Spare Parts List.
- The Δ mark found on some component parts indicates the importance of the safety factor of the part. Therefore, when replacing, be sure to use parts of identical designation.
- Parts marked by * are not always kept in stock. Their delivery time may be longer than usual or they may be unavailable.

Mark No.	Description	Parts No.	Mark No.	Description	Parts No.
Δ 1	Q1,Q4 TRANSISTOR	25A1264M	38	CONTROL ASSY	AW25493
Δ 1	Q3,Q4 TRANSISTOR	25A1100	39	HEADPHONE ASSY (For A-203)	AW25494
Δ 1	Q1,Q2 TRANSISTOR	25C3181N	39	HEADPHONE ASSY (For A-103)	AW25498
Δ 2	Q1,Q2 TRANSISTOR	25C4688	40	SP ASSY (For A-203)	AW25495
Δ 3	T1 POWER TRANSFORMER	AT31538	40	SP ASSY (For A-103)	AW25499
Δ 3	T1 POWER TRANSFORMER	AT31540	41	POWER SW ASSY	AW25496
Δ 4	TERMINAL SCREW	AKE-031	42	TRANS ASSY (For A-203)	AW25497
Δ 5	FU1 FUSE (1.25A)	RSK1023	42	TRANS ASSY (For A-103)	AW25538
Δ 5	FU1 FUSE (100mA)	REK1011	43	POWER AMP ASSY (For A-203)	AW25500
NSP 6	CHASSIS(MET)	ANA1228	43	POWER AMP ASSY (For A-103)	AW25501
7	REAR PANEL (For A-203)	ANC2173	Δ 44	AC POWER CORD	ADG1154
7	REAR PANEL (For A-103)	ANC2177	45	OPEN INSTRUCTIONS	ARE1302
NSP 8	RADIATOR (For A-203)	ANH1464	46	PAPER PROTECTOR A	AHA1660
NSP 8	RADIATOR (For A-103)	ANH1465	47	PAPER PROTECTOR B	AHA1661
9	INSULATOR	PNW1912	48	PAPER PROTECTOR C	AHA1662
10	RING(MET)	ANG1917	49	PACKING CASE (For A-203)	AHD2672
11	PCB HOLDER(MET)	ANG1918	49	PACKING CASE (For A-103)	AHD2673
12	PCB SPACER(PLS)	AEC1546	50	PACKING SHEET	AHG1212
13	PCB SPACER(PLS)	AEC1567			
14	SHEET (A-203 only)	AEB1014			
15	BINDER	AEP-215			
16	PCB MOLD(PP)	AMR2533			
17	SCREW	ABA-298			
18	SCREW	ABA1018			
19	SCREW	ABA1027			
20	SCREW	ABA1082			
21	SCREW (STEEL)	ABA1095			
22	SCREW (STEEL)	ABA1193			
23	SCREW	BBY20P10FZK			
24	SCREW	BCZ30P10FZK			
25	SCREW	BPZ20P10FMC			
26	NUT	HWY091C			
27	SCREW	VPZ20P10FMC			
28	LED LENS	AAK2552			
29	NAME PLATE	PAM1608			
30	ROUND KNOB L (PLS)	AA81540			
31	ROUND KNOB S (PLS)	AA82221			
32	POWER BUTTON	AAD2539			
33	FUNCTION BUTTON	AAD2540			
34	PUSH BUTTON (PLS)	AAD4045			
35	BONNET CASE	ANE1464			
36	FRONT PANEL (For A-203)	AMB2231			
36	FRONT PANEL (For A-103)	AMB2232			
37	FUNCTION ASSY	AW25492			

EXPLODED VIEWS

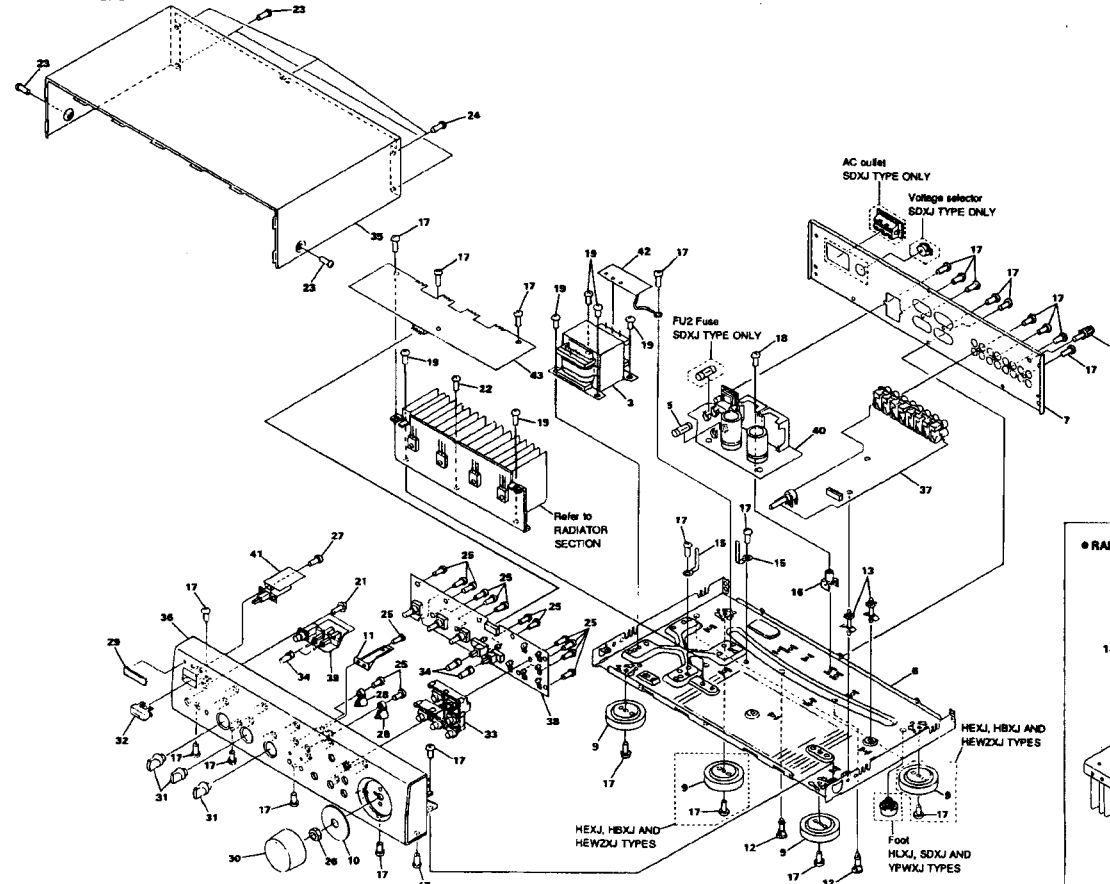

PACKING

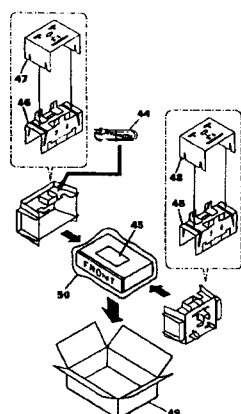

RADIATOR SECTION

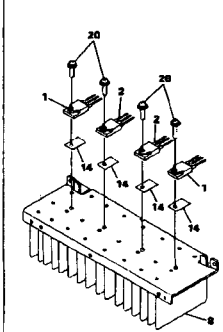

NOTE: Screws adjacent to ∇ mark on product are used for disassembly.

3. SCHEMATIC DIAGRAM

A

B

C

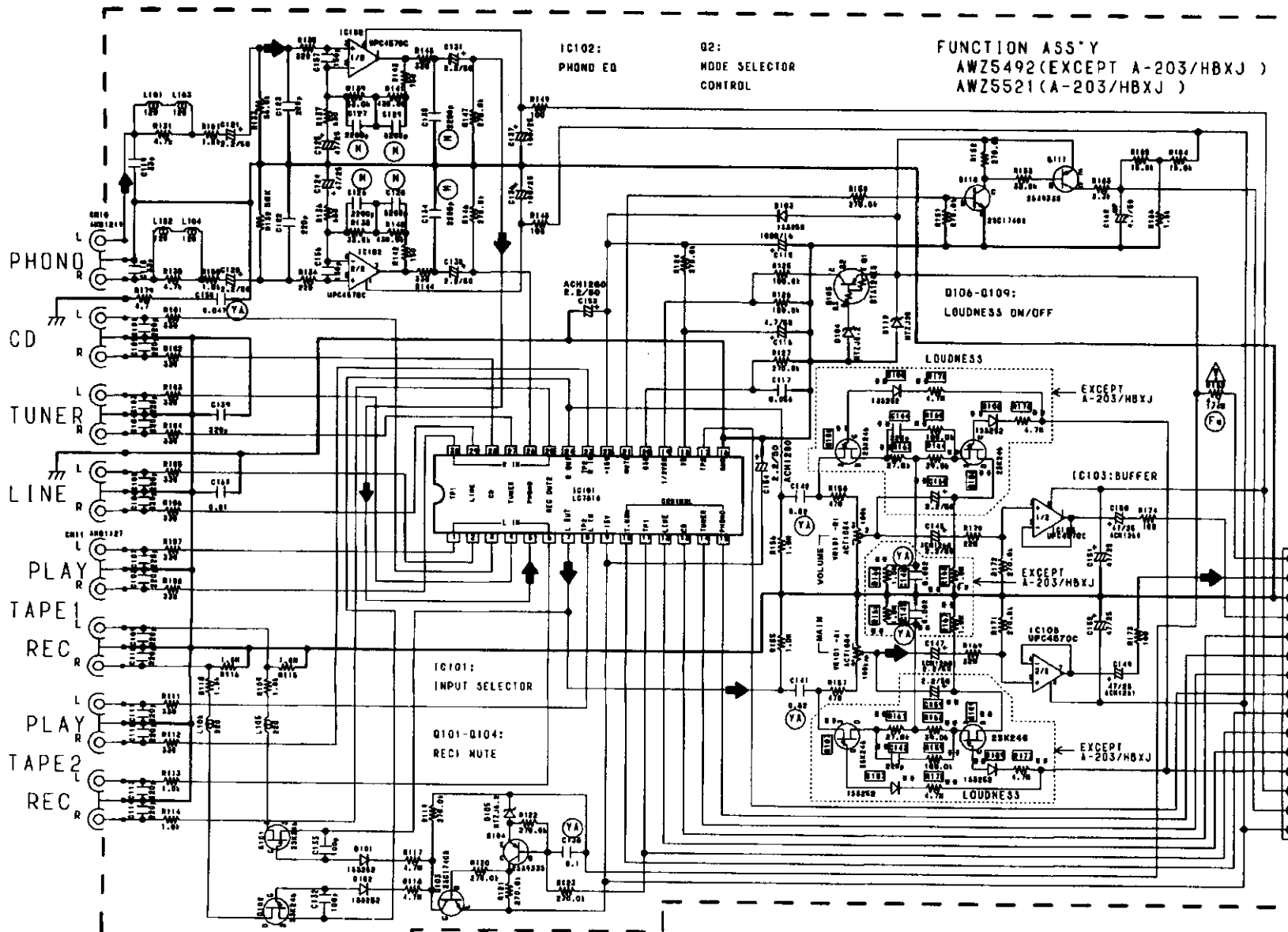

This schematic diagram
 • A-203/HEXJ, HBXJ, HEWZX.
 • A-103/HEXJ, HBXJ, HEWZX.

NOTE:
 ** EXCEPT A-203/HBXJ
 * A-203/HBXJ ONLY

FROM FUNCTION ASS'Y
 +15V
 L
 CND
 R
 CD
 PHONO
 TUNER
 TAPE2
 TMOUT
 TAPE1
 LINE
 LOUDNES
 +15V
 MUTE
 -15V

TO CONTROL ASSY

POWER AMP ASS'Y
 AWZ5500(A-203)
 AWZ5501(A-103)

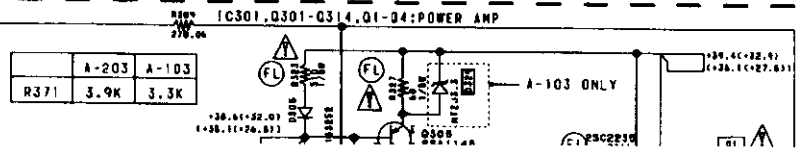

	A-203	A-103		A-203	A-103
Q1, Q2	2SC3161N	2SC4688	R359	100K	82K
Q3, Q4	2SA1264N	2SA1803	R362, R363	330	270

Q317, Q318, Q319

is applicable to the following:
 J,HLXJ and SDXJ
 J,HLXJ,SDXJ and YPWXJ

CONTROL ASS'Y
 AWZ5493(EXCEPT A-203/HBXJ)
 AWZ5523(A-203/HBXJ)

➔ :Audio signal route(Lch)

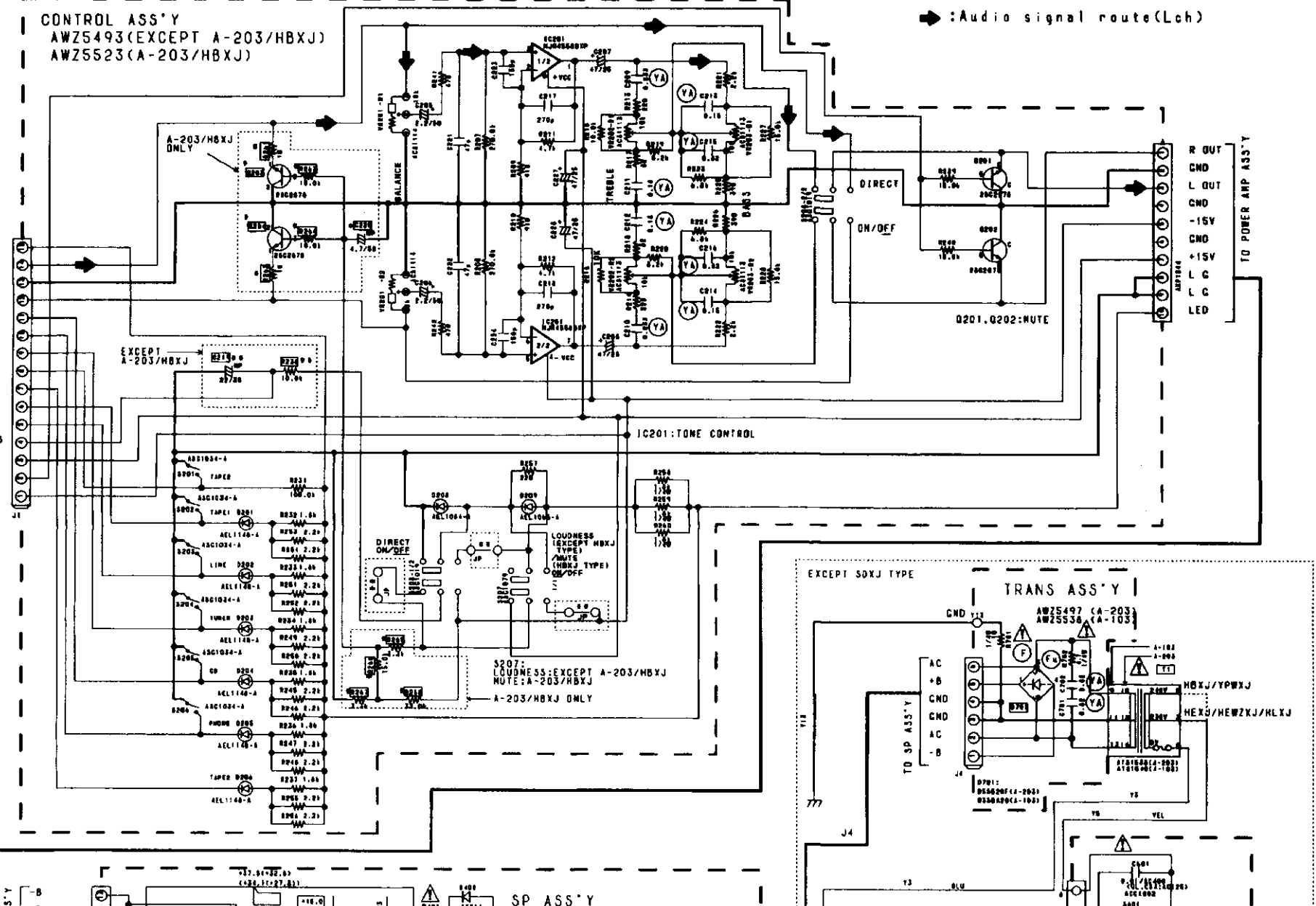

A

B

C

D

E

F

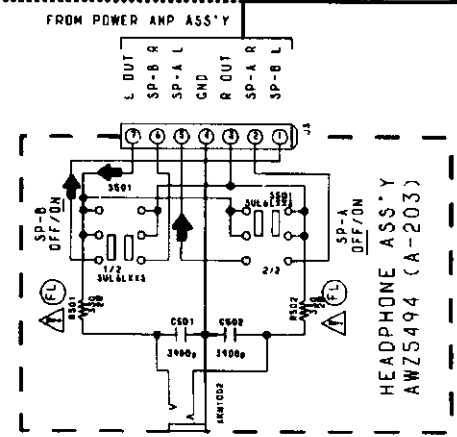
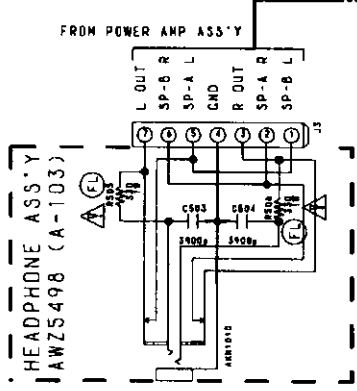
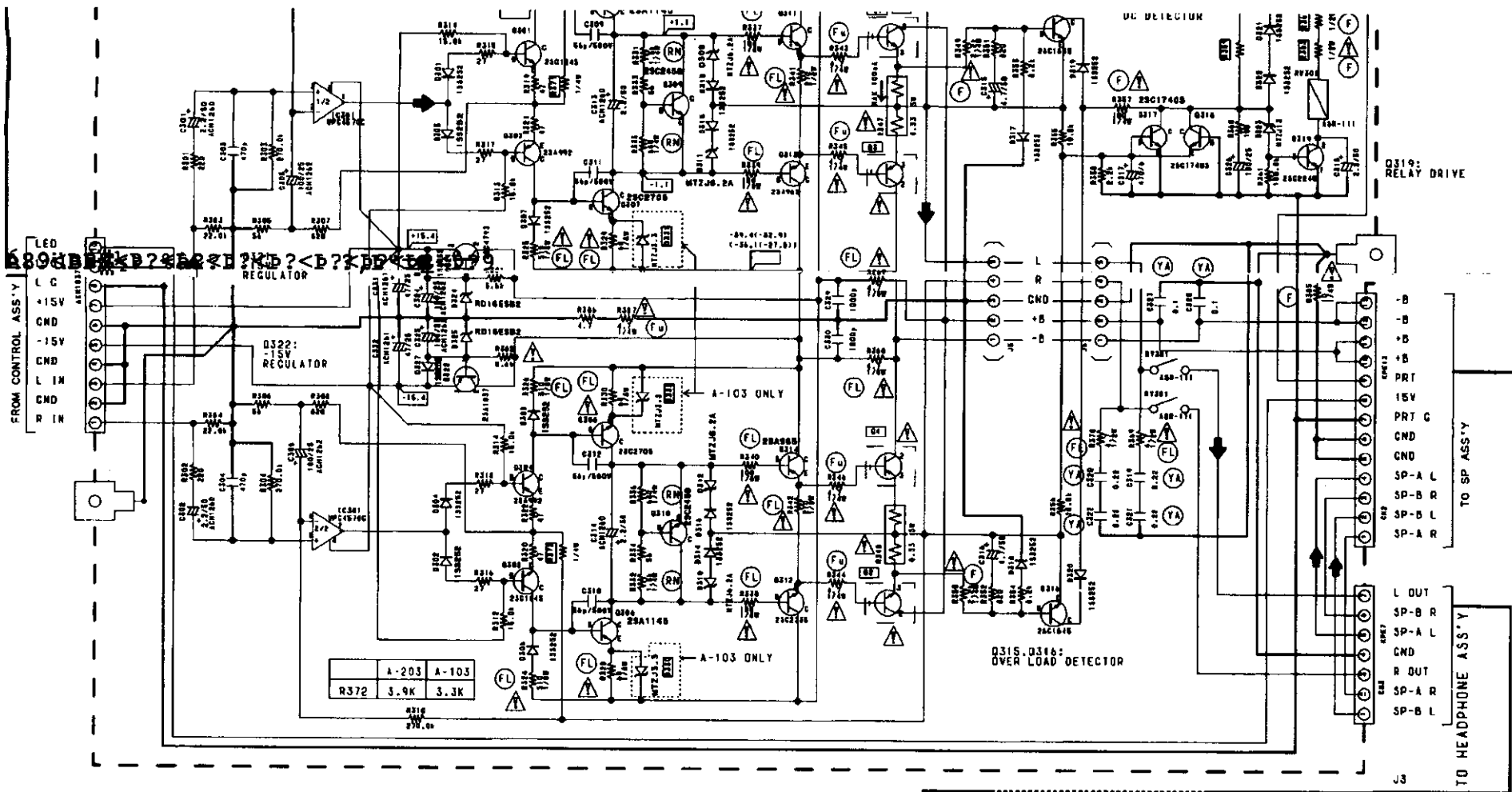

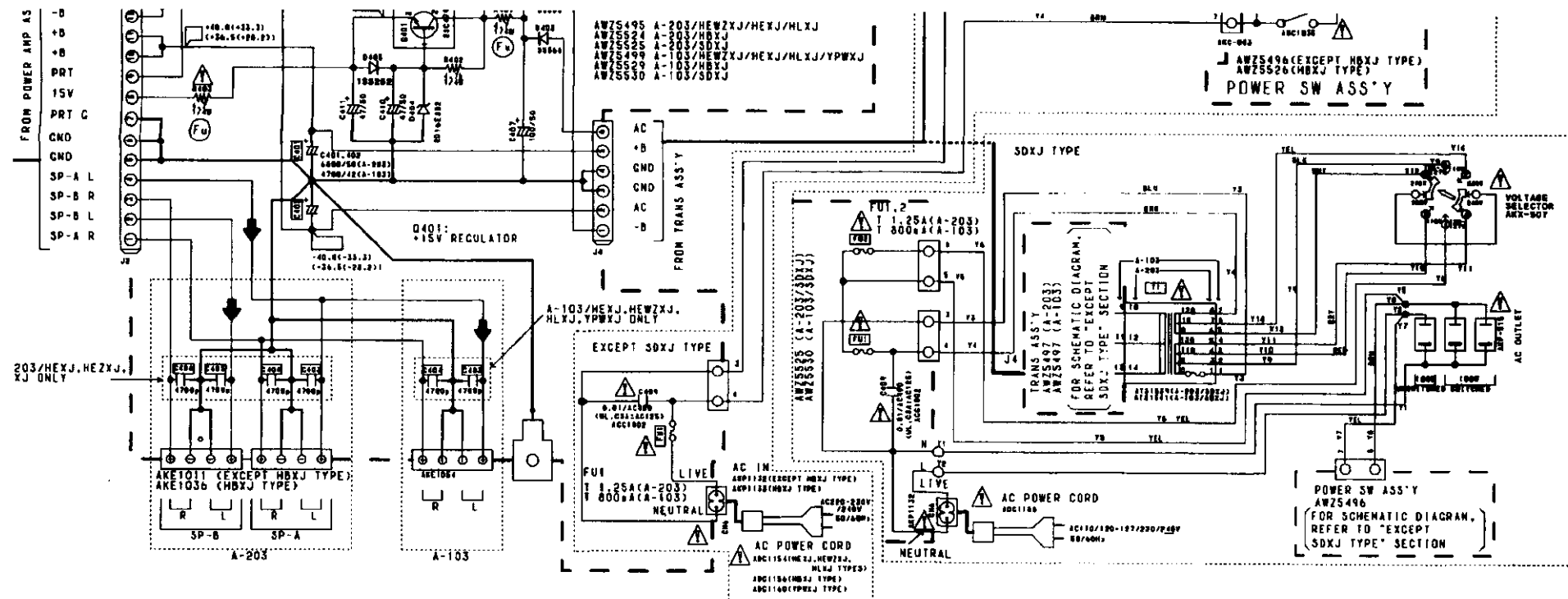

NOTE FOR SCHEMATIC DIAGRAMS (Type 1A)

- When ordering service parts, be sure to refer to "PARTS LIST OF EXPLODED VIEWS" or "PCB PARTS LIST".**
- Since these are basic circuits, some parts of them or the values of some components may be changed for improvement.
- RESISTORS:**
Unit: k: kΩ, M: MΩ, or Ω unless otherwise noted.
Rated power: 1/4W, 1/6W, 1/8W, 1/10W unless otherwise noted.
Tolerance: (F): ±1%, (G): ±2%, (K): ±10%, (M): ±20% or ±5% unless otherwise noted.
- CAPACITORS:**
Unit: p: pF or μF unless otherwise noted.
Ratings: capacitor (μF)/ voltage (V) unless otherwise noted.
Rated voltage: 50V except for electrolytic capacitors.
- COILS:**
Unit: m: mH or μH unless otherwise noted.
- VOLTAGE AND CURRENT:**

	: Signal voltage at rated output.
	or - V :
	DC voltage (V) at no input signal unless otherwise noted.
	Value in () is DC voltage at rated power.
	Value in () is DC voltage for A-103.

	or - mA :
	DC current at no input signal unless otherwise noted.

- OTHERS:**
 - ⊙ or ⊗ : Adjusting point.
 - ◀ : Measurement point.
 - The mark found on some component parts indicates the importance of the safety factor of the parts. Therefore, when replacing, be sure to use parts of identical designation.
- SCH-□ ON THE SCHEMATIC DIAGRAM:**
 - SCH-□ indicates the drawing number of the schematic diagram. (SCH stands for schematic diagram.)
- SWITCHES (Underline indicates switch position):**

CONTROL ASSY	HEADPHONE ASSY
S201 : TAPE2 MONITOR	S501-1 : A(SPEAKERS)ON-OFF
S202 : TAPE1/DAT	S501-2 : B(SPEAKERS)ON-OFF
S203 : LINE	(A-203 ONLY)
S204 : TUNER	
S205 : CD	POWER SW ASSY
S206 : PHONO	S601 : POWER
S207 : LOUDNESS	
(Except HBXJ TYPE)	
MUTING	
(HBXJ TYPE ONLY)	
S208 : DIRECT ON-OFF	

D
E
F

is applicable to the following:
 1. HLXJ and SDXJ
 1. HLXJ, SDXJ and YPWXJ

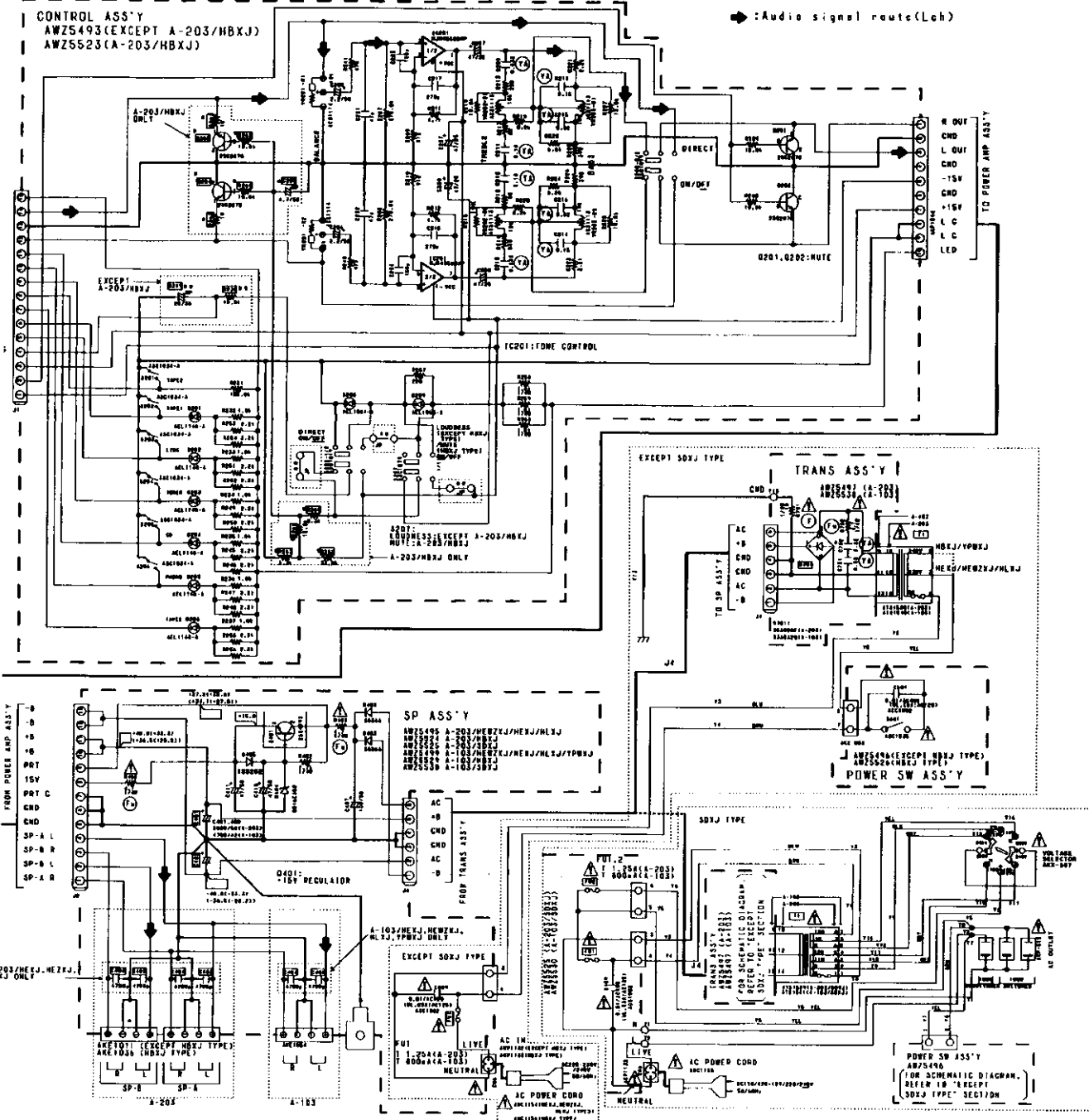

NOTE FOR SCHEMATIC DIAGRAMS (Type 1A)

- When ordering service parts, be sure to refer to "PARTS LIST OF EXPLODED VIEWS" or "PCB PARTS LIST".
- Since these are basic circuits, some parts of them or the values of some components may be changed for improvement.
- RESISTORS:**
 Unit: k: kΩ, M: MΩ, or Ω unless otherwise noted.
 Rated power: 1/4W, 1/8W, 1/8W, 1/10W unless otherwise noted.
 Tolerance: [F]: ±1%, [G]: ±2%, [K]: ±10%, [M]: ±20% or ±5% unless otherwise noted.
- CAPACITORS:**
 Unit: p: pF or μF unless otherwise noted.
 Ratings: capacitor (μF)/voltage (V) unless otherwise noted.
 Rated voltage: 50V except for electrolytic capacitors.
- COILS:**
 Unit: m: mH or μH unless otherwise noted.
- VOLTAGE AND CURRENT:**
 [V]: Signal voltage at rated output.
 or - V :
 DC voltage (V) at no input signal unless otherwise noted.
 Value in () is DC voltage at rated power.
 Value in [] is DC voltage for A-103.
 mA : mA

- OTHERS:**
 - ⊙ or ⊗ : Adjusting point.
 - ⊙ : Measurement point.
 - The Δ mark found on some component parts indicates the importance of the safety factor of the parts. Therefore, when replacing, be sure to use parts of identical designation.
- SCH-□ ON THE SCHEMATIC DIAGRAM:**
 - SCH-□ indicates the drawing number of the schematic diagram. (SCH stands for schematic diagram.)
- SWITCHES (Underline indicates switch position):**

CONTROL ASSY	HEADPHONE ASSY
S201 : TAPE2 MONITOR	S501-1 : A(SPEAKERS)ON-OFF
S202 : TAPE1/DAT	S501-2 : B(SPEAKERS)ON-OFF (A-203 ONLY)
S203 : LINE	
S204 : TUNER	
S205 : CD	POWER SW ASSY
S206 : PHONO	S601 : POWER
S207 : LOUDNESS (Except HBXJ TYPE) MUTING (HBXJ TYPE ONLY)	
S208 : DIRECT ON-OFF	

A
B
C
D
E
F

3. SCHEMATIC DIAGRAM

A
B
C

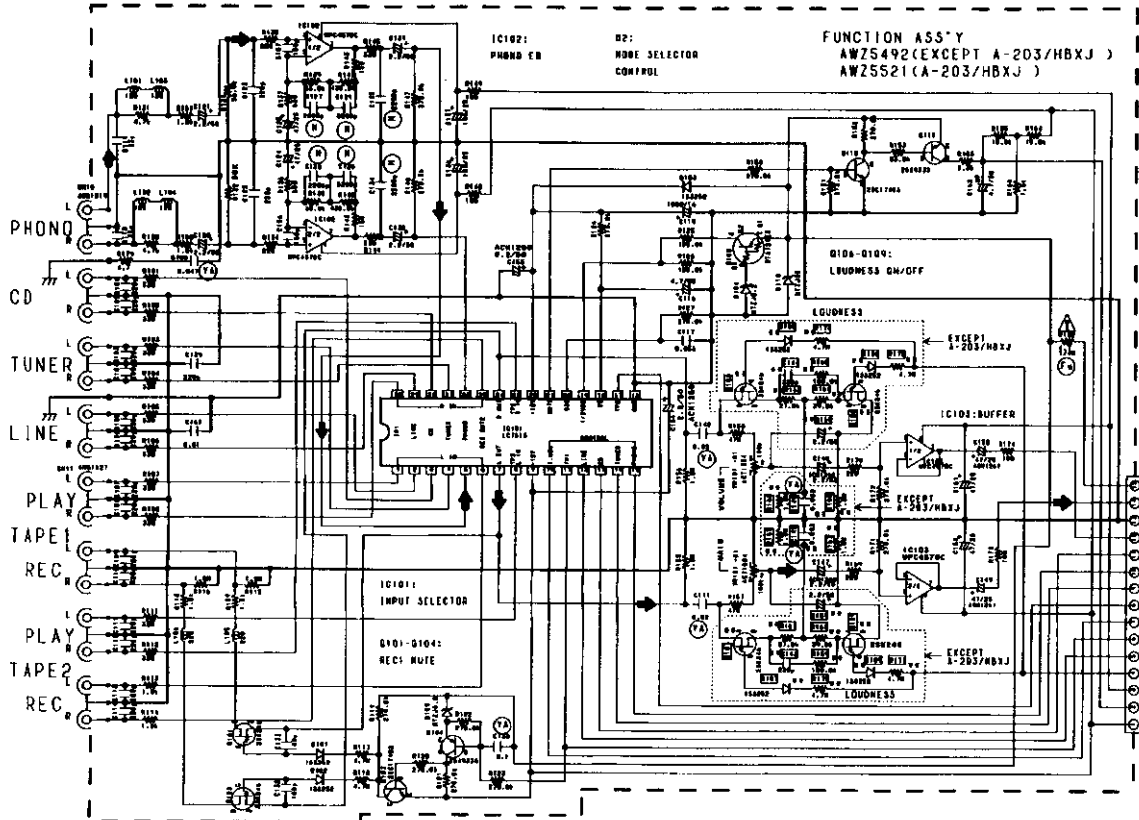

This schematic diagram
• A-203/HEXJ, HBXJ, HEWZJ,
• A-103/HEXJ, HBXJ, HEWZJ.

NOTE:
** EXCEPT A-203/HBXJ
* A-203/HBXJ ONLY

D
E
F

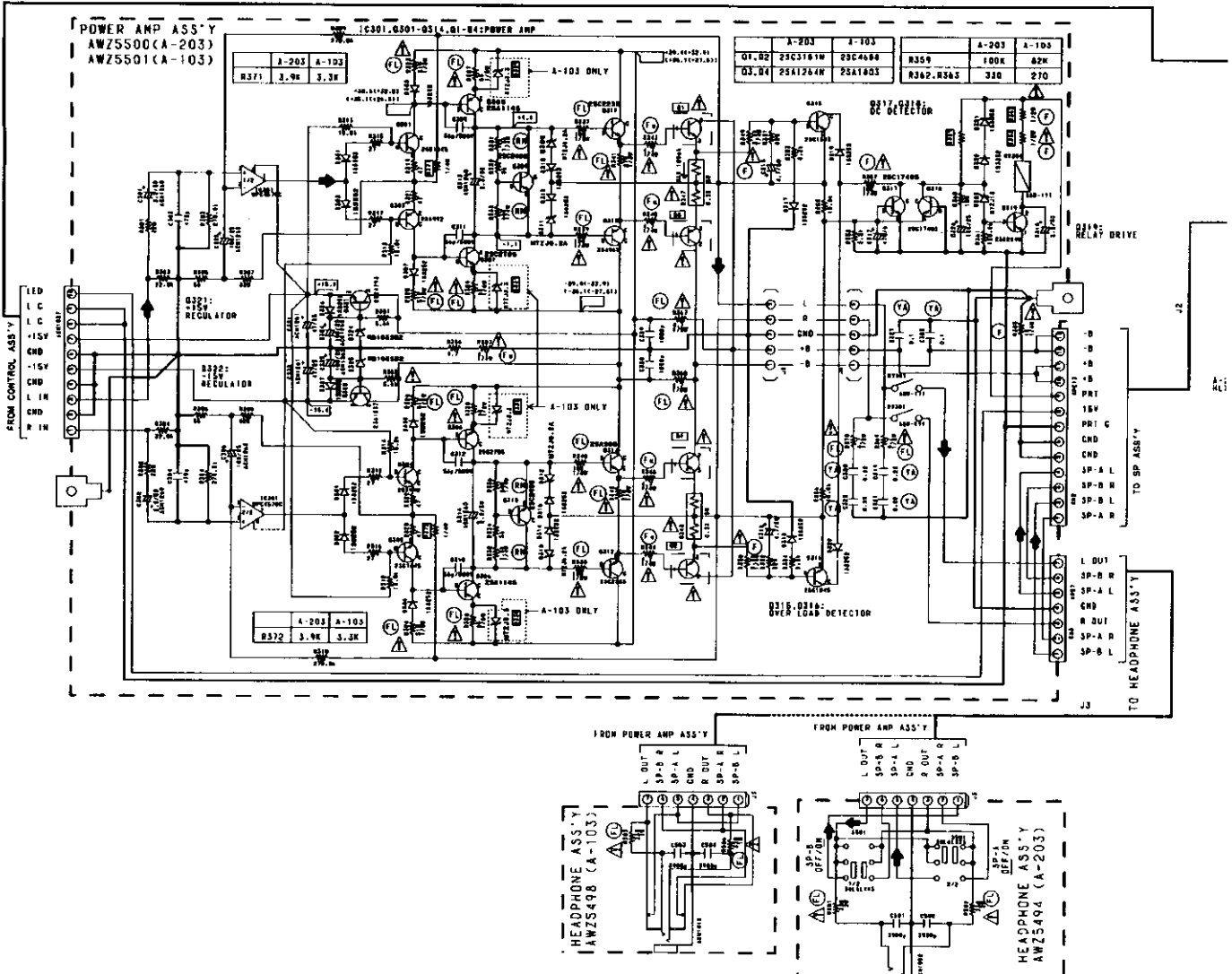

FEED FUNCTION ASS'Y
+15V
L
CND
R
CD
PHONO
TUNER
TAPE2
TAPE1
LINE
LOUDNESS
+15V
MUTE
-15V

TO CONTROL ASS'Y
+15V
-15V
PRT B
PRT C
CND
CND
SP-A L
SP-B R
SP-B L
SP-A R

TO HEADPHONE ASS'Y
L OUT
SP-B R
SP-A L
CND
R OUT
SP-B R
SP-A L

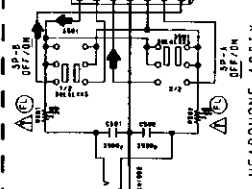
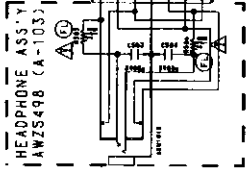

4. PCB CONNECTION DIAGRAMS

• This diagram is viewed from the foil side.

PCB-1

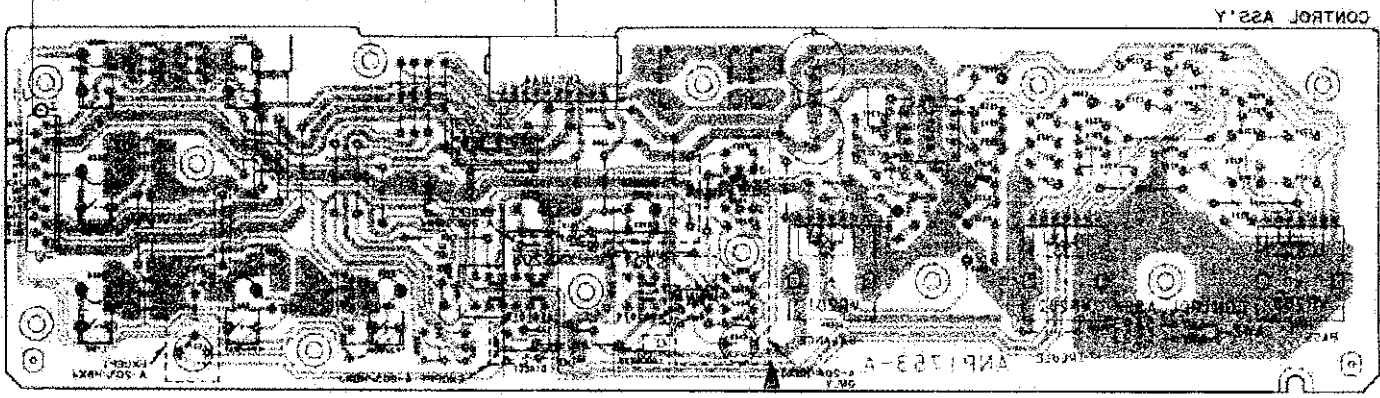
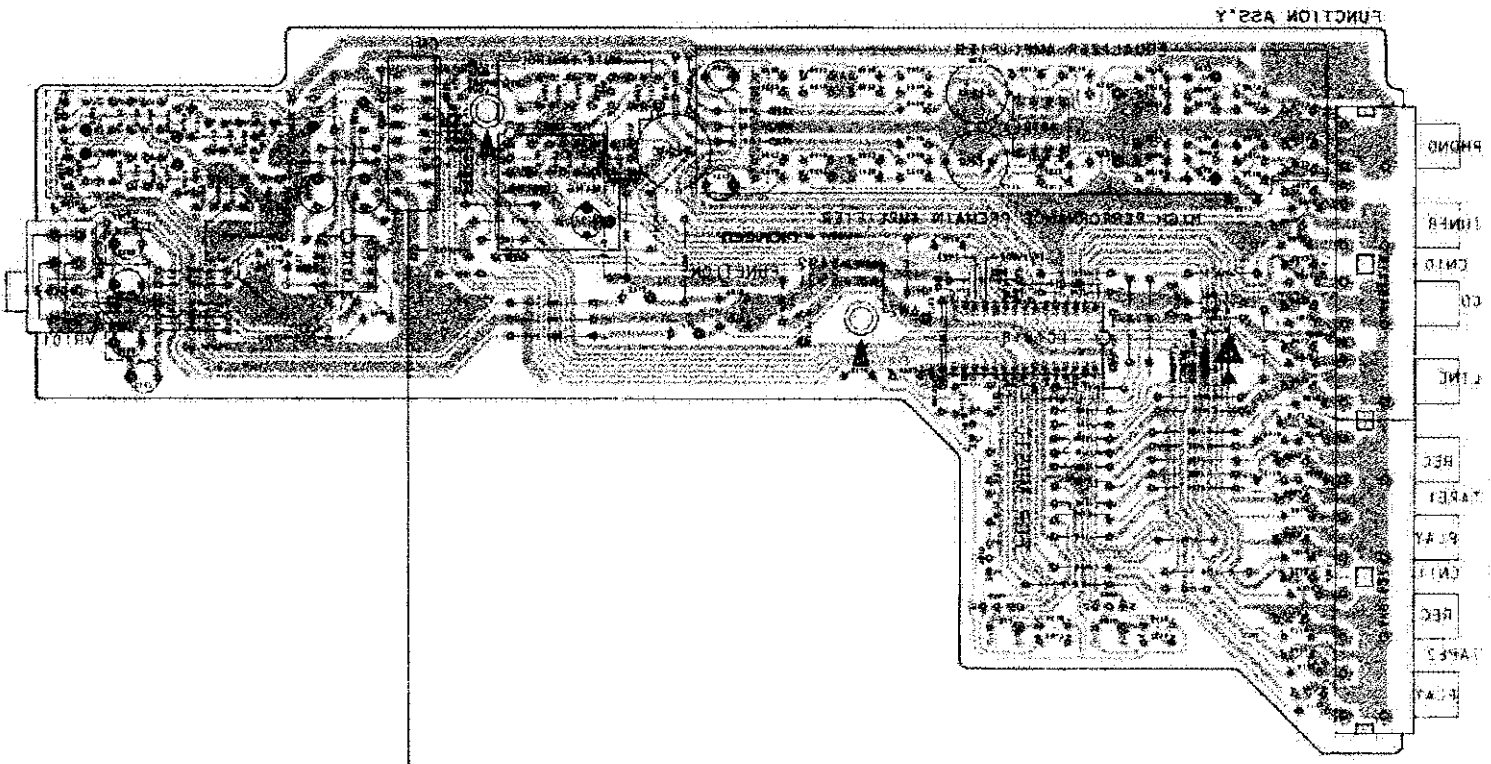

A

B

C

D

1

2

3

4

5

A

B

C

D

PHDND
TDMFR
CMTD
CT
TINE
REC
B.A
CMT
REC
B.A

PHDND

TDMFR

CMTD

CT

TINE

REC

B.A

CMT

REC

B.A

CMT

REC

B.A

CMT

REC

B.A

CMT

REC

B.A

• This diagram is viewed from the mounted parts side.

FUNCTION ASS'Y

PCB-1

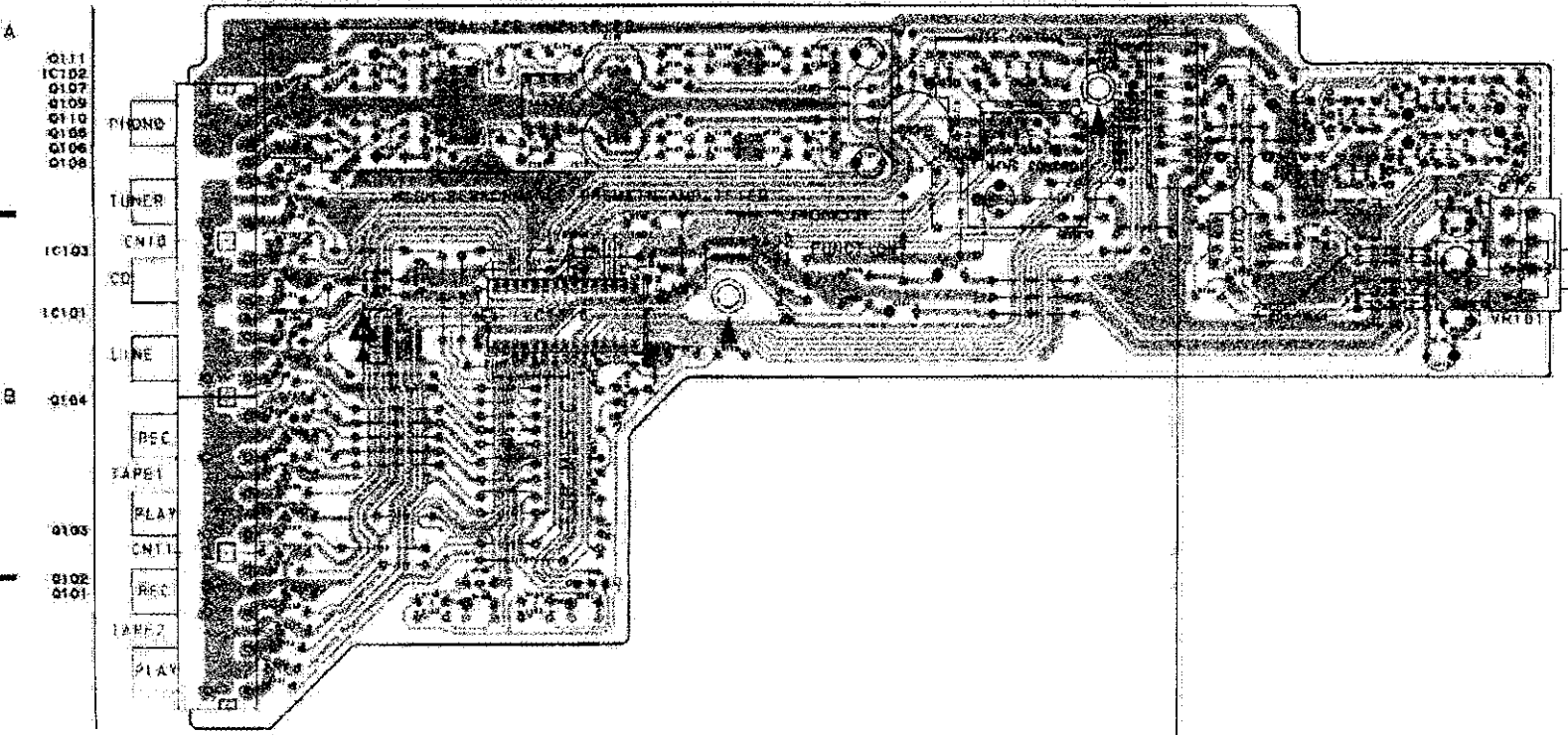

NOTE FOR PCB DIAGRAMS:

1. Part numbers in PCB diagrams match those in the schematic diagrams.
2. A comparison between the main part of PCB and schematic diagrams is shown below.

Symbol in PCB Diagrams	Symbol in Schematic Diagrams	Part Name
		Transistor
		Diode
		Capacitor (Polarized)

3. The transistor terminal marked with E or \bar{E} shows the emitter.
4. The diode terminal marked with @ or \bar{C} shows cathode side.
5. The capacitor terminal marked with @ or \bar{L} shows negative terminal.

CONTROL ASS'Y

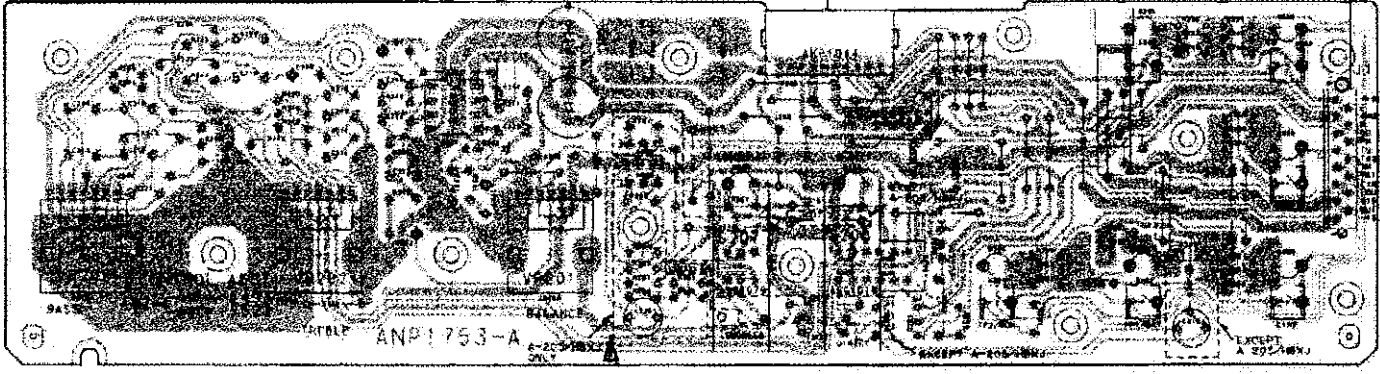

IC201 Q203 Q204 Q202 Q201

• This diagram is viewed from the mounted parts side.

FUNCTION ASS'Y

PCB-1

Q111
C102
Q107
Q109
Q110
Q108
Q106
Q105
Q104
Q103
Q101
Q104
Q104
Q104
Q102
Q101

PHONO
TUNER
VTRG
DE
CONE
REC
TAP 1
FLAY
CMT 1
PCL
CMT 2
CMT 3
CMT 4

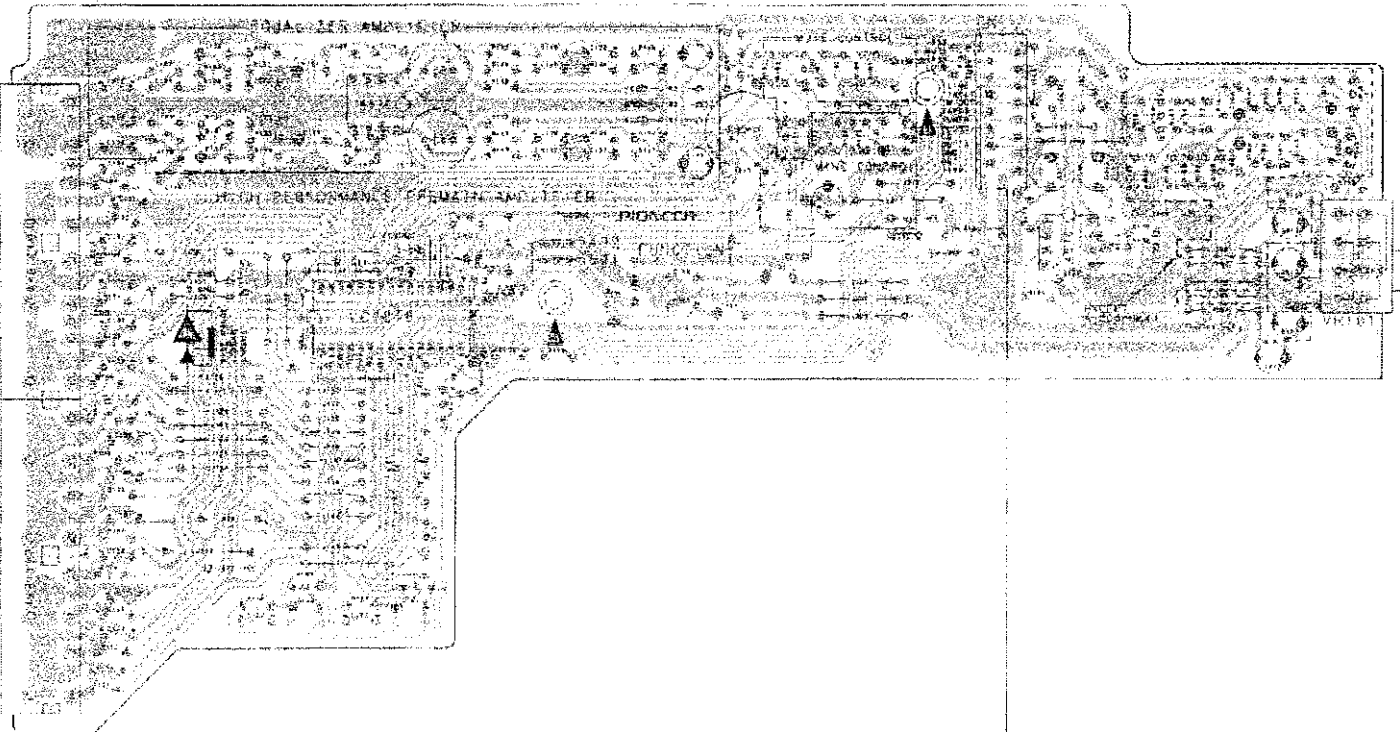

NOTE FOR PCB DIAGRAMS:

1. Part numbers in PCB diagrams match those in the schematic diagrams.
2. A comparison between the main parts of PCB and schematic diagrams is shown below.

Symbol in PCB Diagrams	Symbol in Schematic Diagrams	Part Name
		Transistor
		Diode
		Capacitor (Polarized)

3. The transistor terminal marked with E or shows the emitter.
4. The diode terminal marked with @ or shows cathode side.
5. The capacitor terminal marked with @ or shows negative terminal.

CONTROL ASS'Y

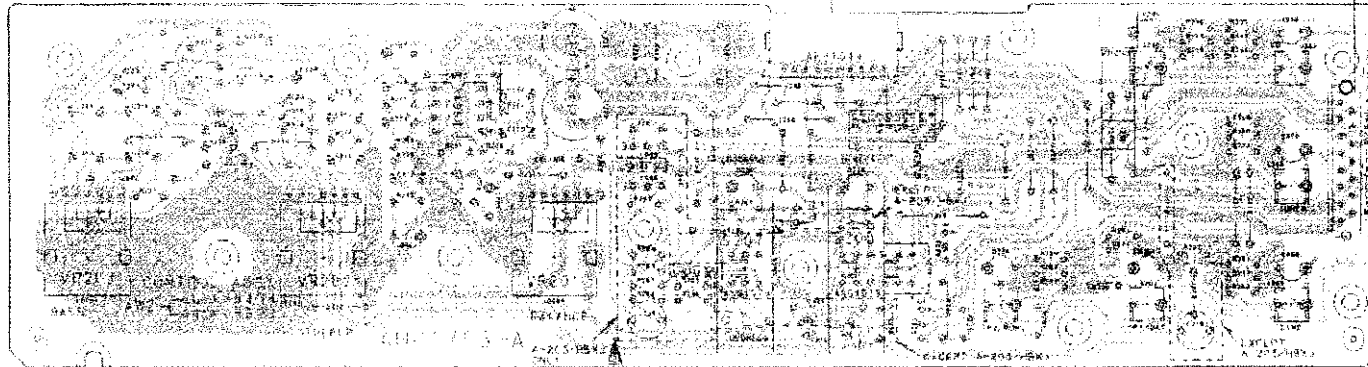

Q201 Q203 Q204 Q202 Q201

• This diagram is viewed from the mounted parts side.

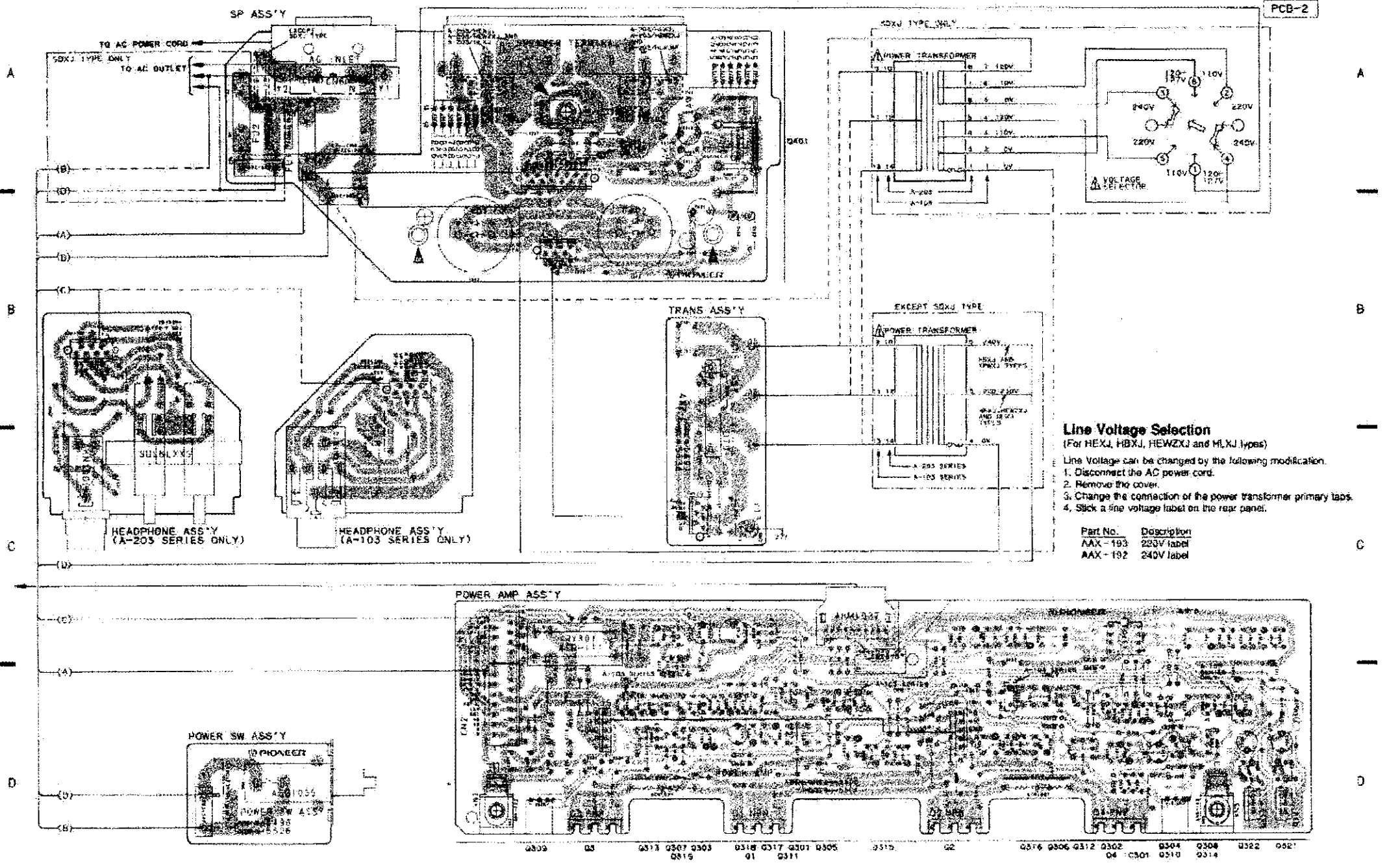

Line Voltage Selection
 (For HEXJ, HBXJ, HEWZXJ and M.KJ types)

Line Voltage can be changed by the following modification.

1. Disconnect the AC power cord.
2. Remove the cover.
3. Change the connection of the power transformer primary taps.
4. Stick a line voltage label on the rear panel.

Part No.	Description
AAX-193	230V label
AAX-192	240V label

Q309 Q2 Q313 Q307 Q303 Q318 Q317 Q301 Q305 Q319 Q2 Q316 Q306 Q312 Q302 Q304 Q304 Q322 Q321 Q315 Q311

PCB-2

This diagram is viewed from the mounted parts side.

PCB-2

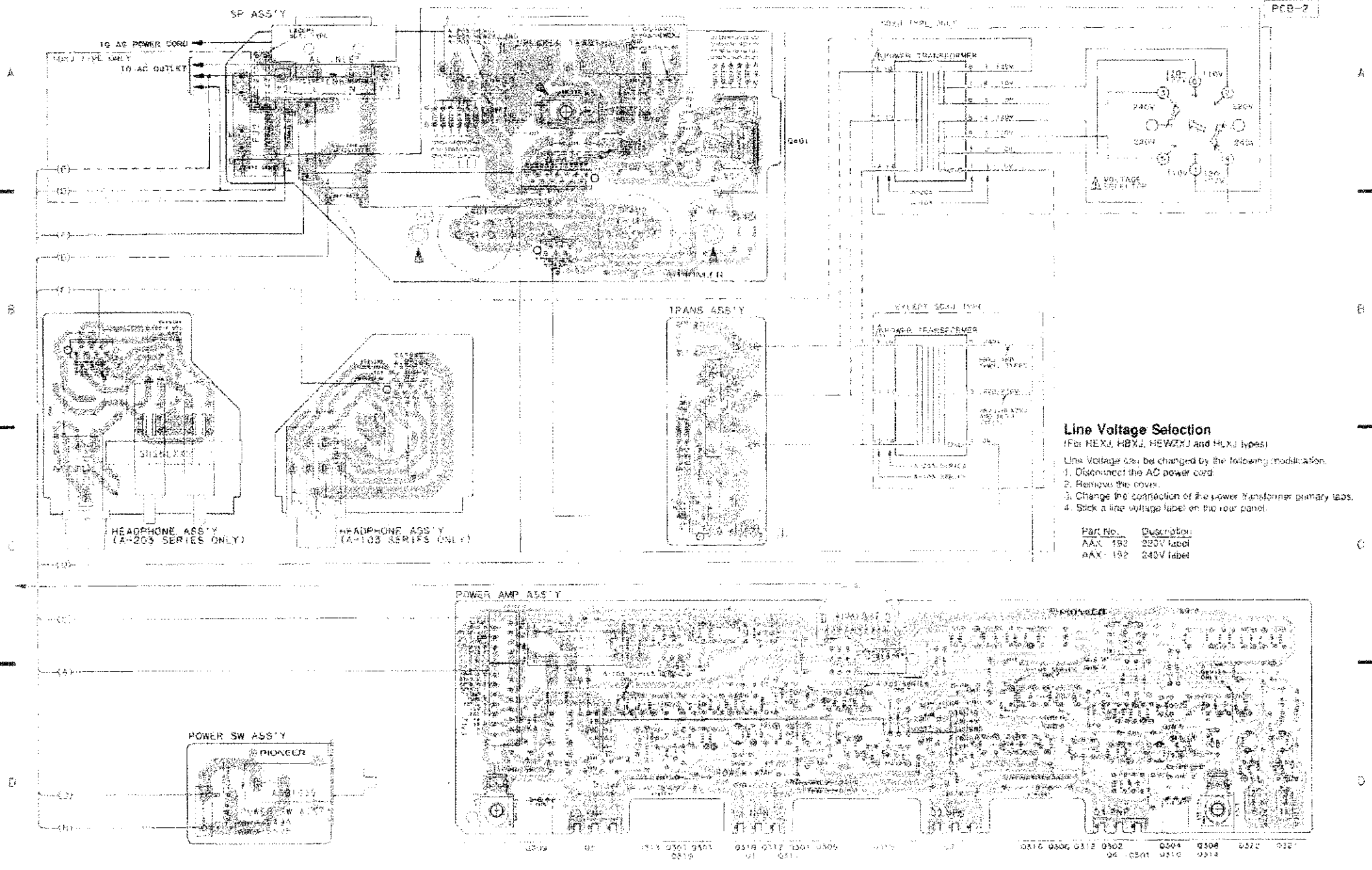

• This diagram is viewed from the foil side.

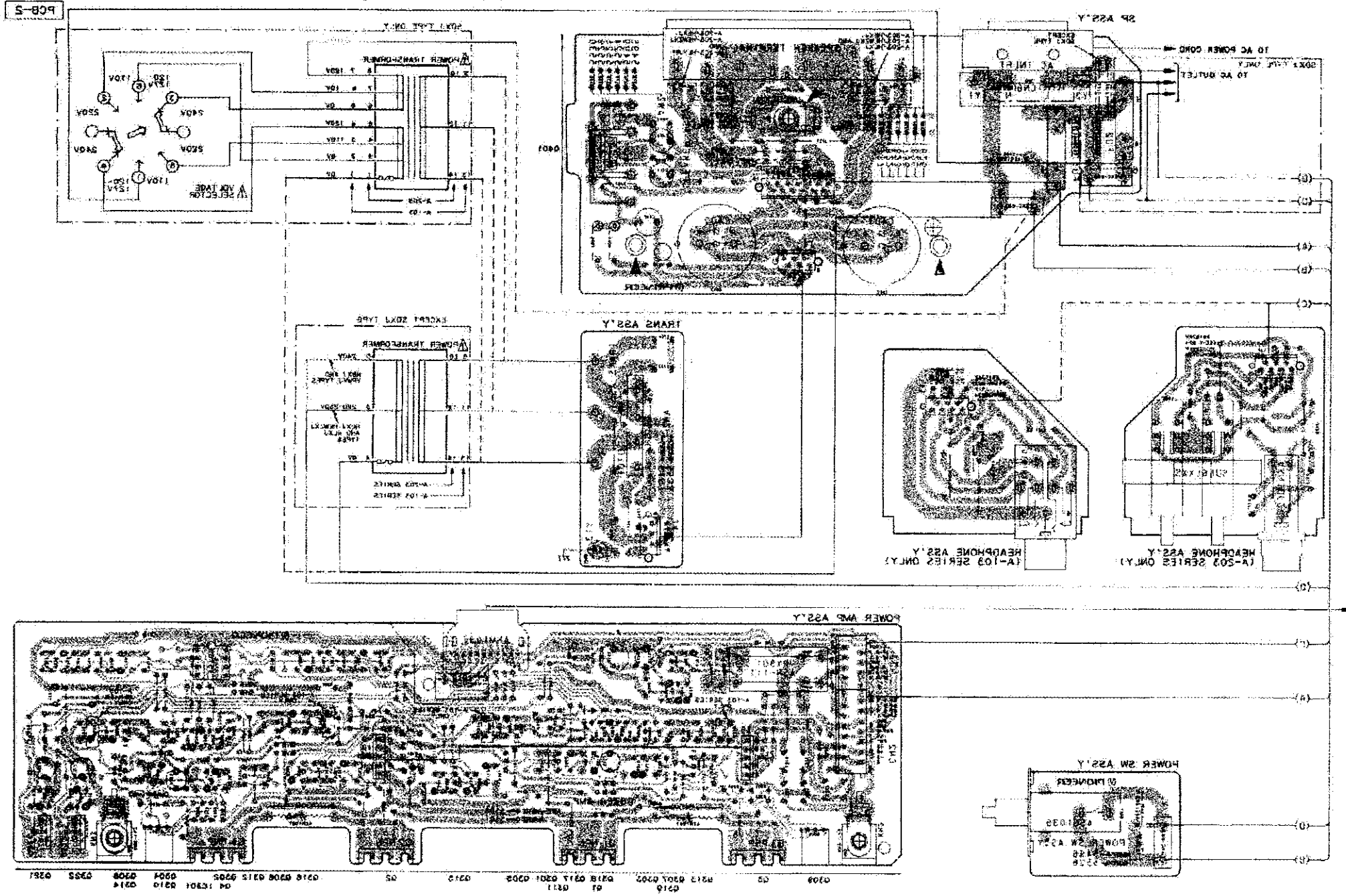

0708 05 0711 05 0712 05 0713 05 0714 05 0715 05 0716 05 0717 05 0718 05 0719 05 0720 05 0721 05 0722 05 0723 05 0724 05 0725 05 0726 05 0727 05 0728 05 0729 05 0730 05 0731 05 0732 05 0733 05 0734 05 0735 05 0736 05 0737 05 0738 05 0739 05 0740 05 0741 05 0742 05 0743 05 0744 05 0745 05 0746 05 0747 05 0748 05 0749 05 0750 05 0751 05 0752 05 0753 05 0754 05 0755 05 0756 05 0757 05 0758 05 0759 05 0760 05

This diagram is viewed from the foil side

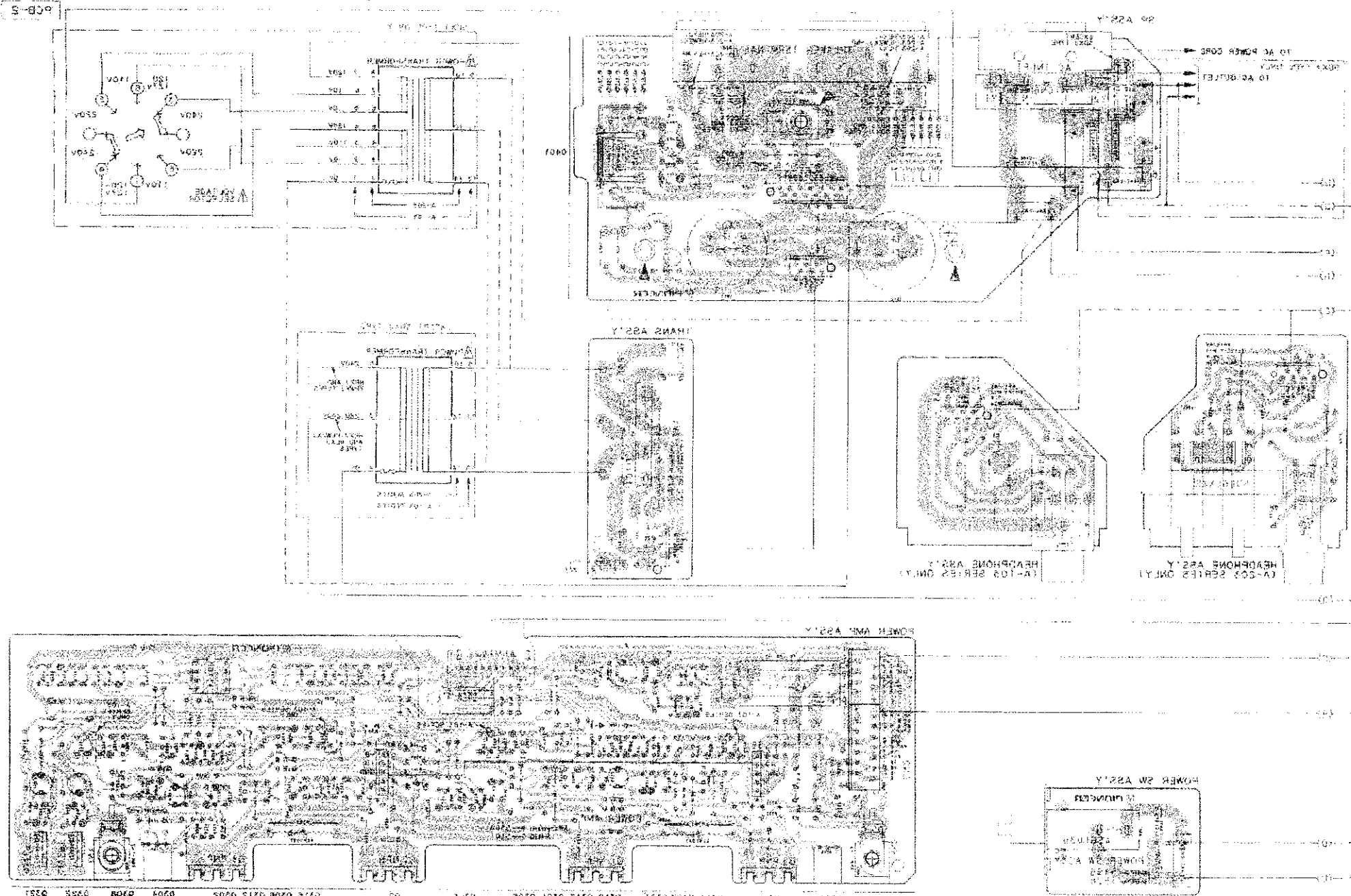

5. BLOCK DIAGRAM

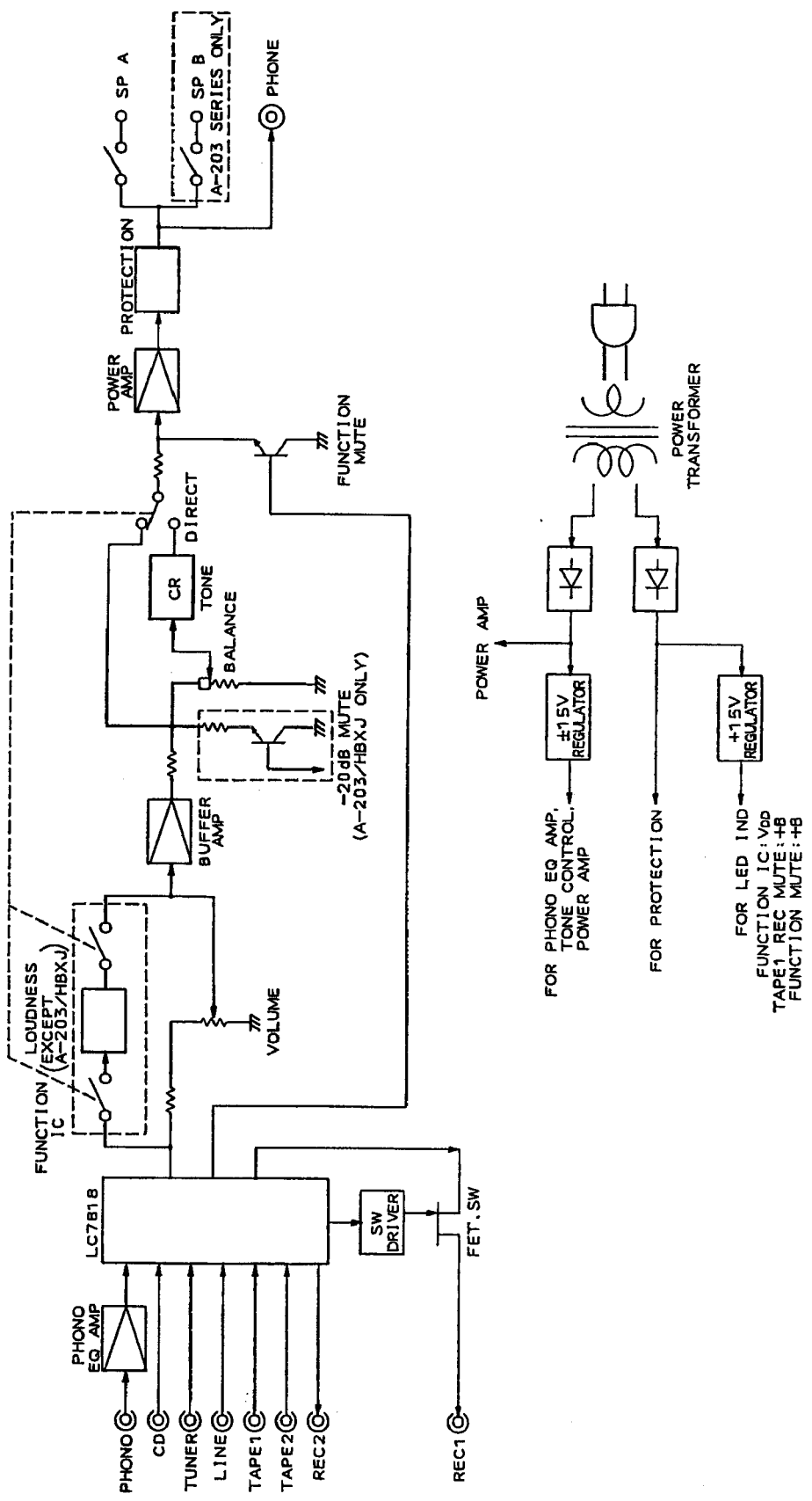

6. PCB PARTS LIST

NOTES:

- Parts marked by "NSP" are generally unavailable because they are not in our Master Spare Parts List.
- The Δ mark found on some component parts indicates the importance of the safety factor of the part. Therefore, when replacing, be sure to use parts of identical designation.
- Parts marked by "⊙" are not always kept in stock. Their delivery time may be longer than usual or they may be unavailable.
- When ordering resistors, first convert resistance values into code form as shown in the following examples.

Ex.1 When there are 2 effective digits (any digit apart from 0), such as 560 ohm and 47k ohm (tolerance is shown by J = 5%, and K = 10%).

560Ω	→	56 × 10 ¹	→	561	RD1/8PM	5 6 1 J
47kΩ	→	47 × 10 ³	→	473	RD1/4PS	4 7 3 J
0.5Ω	→	0R5			RN2H	0 R 5 K
1Ω	→	010			RSIP	0 1 0 K

Ex.2 When there are 3 effective digits (such as in high precision metal film resistors).

5.62kΩ	→	562 × 10 ¹	→	5621	RN1/4PC	5 6 2 1 F
--------	---	-----------------------	---	------	-------	---------	---

Mark	No.	Description	Parts No.	Mark	Mark	No.	Description	Parts No.	Mark
------	-----	-------------	-----------	------	------	-----	-------------	-----------	------

LIST OF ASSEMBLIES

NSP	AF ASSY (For A-203)	AWK1787
	— FUNCTION ASSY	AWZ5492
	— CONTROL ASSY	AWZ5493
	— HEADPHONE ASSY	AWZ5494
	— SP ASSY	AWZ5495
	— POWER SW ASSY	AWZ5496
	— TRANS ASSY	AWZ5497
	— POWER AMP ASSY	AWZ5500
NSP	AF ASSY (For A-103)	AWK1788
	— FUNCTION ASSY	AWZ5492
	— CONTROL ASSY	AWZ5493
	— POWER SW ASSY	AWZ5496
	— HEADPHONE ASSY	AWZ5498
	— SP ASSY	AWZ5499
	— POWER AMP ASSY	AWZ5501
	— TRANS ASSY	AWZ5538

C136, C137	CEAS101M25
C115	CEAS102M16
C120, C121, C130, C131	CEAS2R2M50
C159, C160	CEAS2R2M50
C124, C125, C151, C152	CEAS470M25
C116	CEAS4R7M50
C138	CFTYA104J50
C155	CFTYA473J50
C117	CFTYA563J50
C145, C146	CFTYA823J50
C141, C142	CFTYA824J50
C161	CKCYF103Z50
C126, C127, C134, C135	CQMA222J50
C128, C129	CQMA822J50

RESISTORS

Δ R182	RFA1/4PS4R7J
VR101 (100k - A5 × 2)	ACT1084

Other Resistors RD1/8PM□□□J

OTHERS

CN11 (PIN JACK - 8P)	AKB1127
CN10 (PIN JACK - 8P)	AKB1219
CN1 CONNECTOR(15P)	KPE15

CONTROL ASSY

SEMICONDUCTORS

IC201	NJM4558DXP
Q201, Q202	2SC2878
D209 (Red)	AEL1065
D208 (Orange)	AEL1084
D201 - D206 (Red)	AEL1148

SWITCHES AND RELAYS

S208	ASG1019
S201 - S206	ASG1034
S207	ASG1079

CAPACITORS

C223, C224	CCCSL151J50
C217, C218	CCCSL271J50
C221, C222	CCCSL470J50
C219	CEANP220M35
C205, C206	CEAS2R2M50

FUNCTION ASSY

SEMICONDUCTORS

IC101	LC7818
IC102, IC103	UPC4570C
Q104, Q111	2SA933S
Q103, Q110	2SC1740S
Q101, Q102, Q106 - Q109	2SK246
Q105	DTA124ES
D101 - D103, D106 - D109	1SS252
D110	MTZJ20
D104, D105	MTZJ8.2

COILS AND FILTERS

L101 - L104	LAU121K
L105, L106	LAU221K

CAPACITORS

C147, C148, C153, C154 (2.2/50)	ACH1260
C149, C150 (47/25)	ACH1261
C132, C133	CCCSL101J50
C156, C157	CCCSL151J50
C101 - C114, C122, C123, C139	CCCSL221J50
C143, C144	CCCSL221J50
C118, C119	CCCSL330J50
C162	CEANP4R7M50

Mark No.	Description	Parts No.	Mark	Mark No.	Description	Parts No.	Mark
	C207,C208,C227,C228 C213,C214 C211,C212 C209,C210 C215,C216	CEAS470M25 CFTYA154J50 CFTYA184J50 CFTYA333J50 CFTYA824J50			TRANS ASSY		
	RESISTORS R258-R260 VR202,VR203 (10k-20A×2) VR201 (250k-B×2)	RD1/4PM182J ACSI113 ACSI114			SEMICONDUCTORS D701 (For A-203) D701 (For A-103)	D5SB20F D3SBA20	
	Other Resistors	RD1/8PM□□□J			CAPACITORS C701,C702	CFTYA824J50	
	OTHERS SOCKET (10P)	AKP1044			RESISTORS △ R702	RFA1/4PS100J	
	HEADPHONE ASSY				△ Other Resistors	RD1/4PM□□□J	
	SWITCHES AND RELAYS S501 (A-203 only)				POWER AMP ASSY		
	CAPACITORS C501,C502 (A-203 only) C503,C504 (A-103 only)	SUL6LXXS			SEMICONDUCTORS IC301 Q305,Q306 Q322 Q313,Q314 Q303,Q304	UPC4570C 2SA1145 2SA1837 2SA965 2SA992	
	RESISTORS △ R501,R502 (A-203 only) △ R505,R506 (A-103 only)	CKCYB392K50 CKCYB392K50			Q317,Q318 Q301,Q302,Q315,Q316 Q311,Q312 Q319 Q309,Q310	2SC1740S 2SC1845 2SC2235 2SC2240 2SC2458	
	OTHERS JACK (Headphone) (For A-203) JACK (Headphone) (For A-103)	RS2LMF331J RS1LMF331J			Q307,Q308 Q321 D301-D308,D313-D322 D326,D327 D323	2SC2705 2SC4793 1SS252 1SS252 MTZJ13	
	SP ASSY	AKN1002 AKN1010			D329-D332 (A-103 only) D309-D312 D324,D325	MTZJ3.3 MTZJ6.2A RD16ESB2	
	SEMICONDUCTORS Q401 D405 D404 D402,D403	2SC4793 1SS252 RD16ESB2 S5566			SWITCHES AND RELAYS RY301	ASR-111	
	CAPACITORS △ C409 (0.01/400) C401,C402 (6800/50) (For A-203) C401,C402 (4700/42) (For A-103) C407 C410,C411	ACG1002 ACH1105 ACH1269 CEAS101M50 CEAS470M50			CAPACITORS C301,C302,C313,C314 (2.2/50) C331,C332 (47/25) C305,C306,C324,C325 (1.00/25) C309-C312 C326	ACH1260 ACH1261 ACH1262 CCCSL560K500 CEAS101M25	
	C403,C404 C405,C406 (A-203 only)	CKCYB472K50 CKCYB472K50			C318 C317 C315,C316 C327,C328 C319-C322	CEAS2R2M50 CEAS471M6 CEAS4R7M50 CFTYA104J50 CFTYA224J50	
	RESISTORS △ R401,R403	RFA1/4PS4R7J			C329,C330 C303,C304	CKCYB102K50 CKCYB471K50	
	Other Resistors	RD1/4PM□□□J			RESISTORS △ R347,R348 (0.33/5W) △ R362,R363 (For A-203) △ R362,R363 (For A-103) △ R369,R370 △ R385	ACN-139 RD1/2PMF331J RD1/2PMF271J RD1/2PMFL4R7J RD1/4PMF100J	
	OTHERS SCREW SPEAKER TERMINAL 8-P (For A-203) SPEAKER TERMINAL 4-P (For A-103) △ CN6 (AC INLET-1P)	ABA-298 AKE1011 AKE1054 AKP1132			△ R357 △ R349,R350 △ R337-R340 △ R341,R342 △ R367,R368	RD1/4PMF101J RD1/4PMF222J RD1/8MMF101J RD1/8MMF271J RD1/8MMF4R7J	
	POWER SW ASSY	ASG1035					
	SWITCHES AND RELAYS △ S601						
	CAPACITORS △ C601 (0.01/400)	ACG1002					

A-203, A-103

<u>Mark</u>	<u>No.</u>	<u>Description</u>	<u>Parts No.</u>	<u>Mark</u>
△	R323	-R326	RD1/8MMF511J	
△	R327	-R330	RD1/8MMF680J	
	R371,R372	(For A-203)	RDR1/4PM392J	
	R371,R372	(For A-103)	RDR1/4PM332J	
△	R343	-R346	RFA1/4PS4R7J	
	R331,R332		RNI/4PC1501F	
	R335,R336		RNI/4PC6800F	
	Other Resistors		RD1/8PM□□□J	
OTHERS				
	PLUG	(10P)	AKM1037	
	CN2	CONNECTOR(13P)	KPE13	
	CN3	CONNECTOR(7P)	KPE7	

7. IC INFORMATION

● The information shown in the list is basic information and may not correspond exactly to that shown in the schematic diagrams.

■ **LC7818 (IC101)**
Input Selector IC

● **Block diagram**

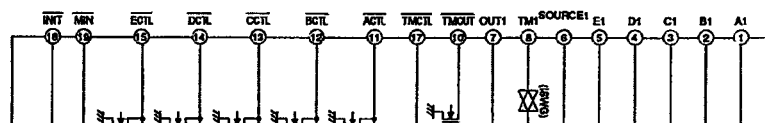

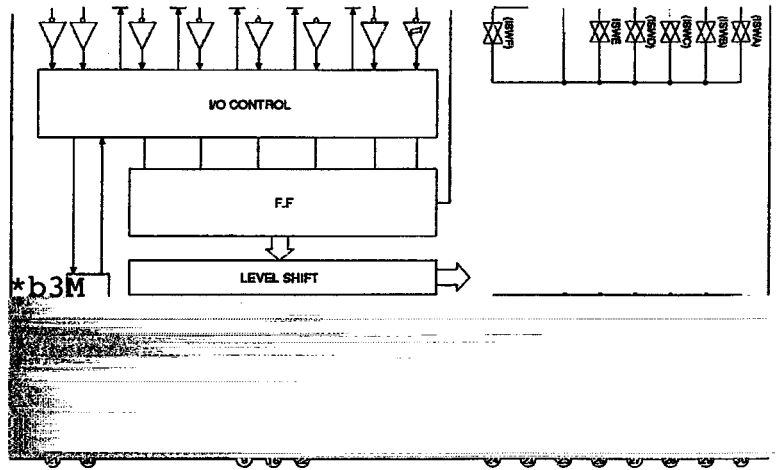

● Pin Function

MUTE CR

VEE VSS VDD

OUT2 TM2 SOURCE2 E2 D2 C2 B2 A2

No.	Name	Function
1	A1	Audio signal input
2	B1	
3	C1	
4	D1	
5	E1	
6	SOURCE1	Recording output
7	OUT1	Audio signal output
8	TM1	Audio signal input
9	VEE	1. When power supply (+) is used: VSS=VEE=GND 2. When power supply (+-) is used: VSS=GND, VEE=(-)V
10	TMOUT	TM ON/OFF display LED driver output
11	ACTL	Input/output pin for analog switch control and display LED driver output
12	BCTL	
13	CCTL	
14	DCTL	
15	ECTL	
16	VSS	1. When power supply (+) is used: VSS=VEE=GND 2. When power supply (+-) is used: VSS=GND, VEE=(-)V

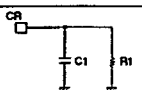
No.	Name	Function																					
17	TMCTL	TM control input																					
18	INIT	Mode setting input Operations According to the Combination of INIT and MIN Inputs																					
19	MIN																						
		<table border="1"> <thead> <tr> <th>INIT</th> <th>MIN</th> <th>Operations</th> </tr> </thead> <tbody> <tr> <td>H</td> <td>M</td> <td>Localization</td> </tr> <tr> <td>H</td> <td>L</td> <td>Backup</td> </tr> <tr> <td>H</td> <td>H</td> <td>Auto function</td> </tr> <tr> <td>L</td> <td>M</td> <td>Mute</td> </tr> <tr> <td>L</td> <td>L</td> <td>Initialize (Circuit A)</td> </tr> <tr> <td>L</td> <td>H</td> <td>Reset</td> </tr> </tbody> </table>	INIT	MIN	Operations	H	M	Localization	H	L	Backup	H	H	Auto function	L	M	Mute	L	L	Initialize (Circuit A)	L	H	Reset
INIT	MIN	Operations																					
H	M	Localization																					
H	L	Backup																					
H	H	Auto function																					
L	M	Mute																					
L	L	Initialize (Circuit A)																					
L	H	Reset																					
20	CR	Clock oscillation input/output Connected to C1 and R1 																					
21	MUTE	Mute control output																					
22	VDD	Power supply																					
23	TM2	Audio signal input																					
24	OUT2	Audio signal output																					
25	SOURCE2	Recording output																					
26	E2	Audio signal input																					
27	D2																						
28	C2																						
29	B2																						
30	A2																						

8. FOR A-203/HBXJ, HEWZXJ, HLXJ, SDXJ, A-103/HBXJ, HEWZXJ, HLXJ, SDXJ AND YPWXJ

NOTES:

- Parts marked by "NSP" are generally unavailable because they are not in our Master Spare Parts List.
- The Δ mark found on some component parts indicates the importance of the safety factor of the part. Therefore, when replacing, be sure to use parts of identical designation.
- Parts marked by "●" are not always kept in stock. Their delivery time may be longer than usual or they may be unavailable.

8.1 CONTRAST OF MISCELLANEOUS PARTS FOR A-203/HBXJ, HEWZXJ, HLXJ AND SDXJ. A-203/HBXJ, HEWZXJ, HLXJ, SDXJ and A-203/HEXJ have the same construction except for the following:

Mark	Symbol & Description	Part No.					Remarks
		A-203 HEXJ	A-203 HBXJ	A-203 HEWZXJ	A-203 HLXJ	A-203 SDXJ	
NSP	AF assembly	AWK1787	AWK1822	AWK1787	AWK1787	AWK1823	
	FUNCTION assembly	AWZ5492	AWZ5521	AWZ5492	AWZ5492	AWZ5492	
	CONTROL assembly	AWZ5493	AWZ5523	AWZ5493	AWZ5493	AWZ5493	
	SP assembly	AWZ5495	AWZ5524	AWZ5495	AWZ5495	AWZ5525	
	POWER SW assembly	AWZ5496	AWZ5526	AWZ5496	AWZ5496	AWZ5496	
Δ	T1 Power transformer (AC220—230V/240V)	ATSI538	ATSI538	ATSI538	ATSI538	
Δ	T1 Power transformer (AC110V/120—127V/220V/240V)	ATSI539	
Δ	Voltage selector (AC110V/120—127V/220V/240V)	AKX—507	Refer to page5.
Δ	AC outlet	AKP—515	Refer to page5.
Δ	FL2 Fuse (1.25A)	REK1023	Refer to page5.
Δ	AC power cord	ADG1154	ADG1156	ADG1154	ADG1154	ADG1158	
	Rear panel	ANC2173	ANC2174	ANC2172	ANC2201	ANC2175	
	Insulator (for front/rear)	PNW1912	PNW1912	PNW1912	
	Insulator (for front)	DXA1490	DXA1490	
	Foot (for rear)	AEC1505	AEC1505	
	Front panel	AMB2231	AMB2233	AMB2231	AMB2231	AMB2231	
	Operating instructions (English/French/German/Italian/ Swedish/Spanish/Dutch/ Portuguese)	ARE1302	
	Operating instructions (English)	ARB1468	
	Operating instructions (German)	ARC1455	
	Operating instructions (English/Chinese)	ARE1300	
	Operating instructions (English/Spanish/Chinese)	ARE1301	
	Packing case	AHD2672	AHD2672	AHD2672	AHD2701	AHD2701	

FUNCTION ASSEMBLY

AWZ5521 and AWZ5492 have the same construction except for the following:

Mark	Symbol & Description	Part No.		Remarks
		AWZ5492	AWZ5521	
	D106-D109 Q106-Q109	1SS252 2SK246	
	R159, R160 R161, R162 R163, R164 R165-R168 R175-R178	RD1/8PM104J RD1/8PM273J RD1/8PM393J RD1/8PM105J RD1/8PM475J	
	C143, C144 C145, C146 C159, C160	CCCSL221J50 CFTXA823J50 CEAS2R2M50	

CONTROL ASSEMBLY

AWZ5523 and AWZ5493 have the same construction except for the following:

Mark f 3M	Symbol & Description	Part No.		Remarks
		AWZ5493	AWZ5523	
	Q203, Q204	2SC2878	
	R238 R261, R262 R263, R264 R265, R267 R266	RD1/8PM103J RD1/8PM100J RD1/8PM103J RD1/8PM332J RD1/8PM153J	
	R268	RD1/8PM333J	
	C219 C225	CEANP220M35 CEANP4R7M50	

SP ASSEMBLY

AWZ5524, AWZ5525 and AWZ5495 have the same construction except for the following:

Mark	Symbol & Description	Part No.			Remarks
		AWZ5495	AWZ5524	AWZ5525	
	C403-C406	CKCYB472K50	
	Speaker terminal 8-P	AKE1011	AKE1036	AKE1011	
Δ	CN6 (AC INLET-1P)	AKP1132	AKP1133	AKP1132	

POWER SW ASSEMBLY

Although AWZ5526 and AWZ5496 are different in part number, they have the same service parts.

8.2 CONTRAST OF MISCELLANEOUS PARTS FOR A-103/HBXJ, HEWZXJ, HLXJ SDXJ AND YPWXJ.

A-103/HBXJ, HEWZXJ, HLXJ, SDXJ, YPWXJ and A-103/HEXJ have the same construction except for the following:

Mark	Symbol & Description	Part No.						Remarks
		A-103 HEXJ	A-103 HBXJ	A-103 HEWZXJ	A-103 HLXJ	A-103 SDXJ	A-103 YPWXJ	
NSP	AF assembly SP assembly POWER SW assembly	AWK1788 AWZ5499 AWZ5496	AWK1825 AWZ5529 AWZ5526	AWK1788 AWZ5499 AWZ5496	AWK1788 AWZ5499 AWZ5496	AWK1826 AWZ5530 AWZ5496	AWK1788 AWZ5499 AWZ5496	
Δ	T1 Power transformer (AC220-230V/240V)	ATSI540	ATSI540	ATSI540	ATSI540	ATSI540	
Δ	T1 Power transformer (AC110V/120-127V/220V/240V)	ATSI541	
Δ	Voltage selector (AC110V/120-127V/220V/240V)	AKX-507	Refer to page5.
Δ	AC outlet	AKP-515	Refer to page5.
Δ	FU2 Fuse (800mA)	REK1021	Refer to page5.
Δ	AC power cord	ADG1154	ADG1156	ADG1154	ADG1154	ADG1158	ADG1160	
	Rear panel	ANC2177	ANC2178	ANC2176	ANC2202	ANC2179	ANC2178	
	Insulator	PNW1912	PNW1912	PNW1912	
	Foot	AEC1505	AEC1505	AEC1505	
	Front panel	AMB2232	AMB2232	AMB2232	AMB2234	AMB2234	AMB2234	
	Operating instructions (English/French/German/Italian/ Swedish/Spanish/Dutch/ Portuguese)	ARE1302	
	Operating instructions (English)	ARB1468	ARB1468	
	Operating instructions (German)	ARC1455	
	Operating instructions (English/Chinese)	ARE1300	
	Operating instructions (English/Spanish/Chinese)	ARE1301	
	Packing case	AHD2673	AHD2673	AHD2673	AHD2702	AHD2702	AHD2673	

SP ASSEMBLY

AWZ5529, AWZ5530 and AWZ5499 have the same construction except for the following:

Mark	Symbol & Description	Part No.			Remarks
		AWZ5499	AWZ5529	AWZ5530	
	C403, C404	CKCYB472K50	
Δ	CN6 (AC INLET-1P)	AKP1132	AKP1133	AKP1132	

POWER SW ASSEMBLY

Although AWZ5526 and AWZ5496 are different in part number, they have the same service parts.

9. PANEL FACILITIES

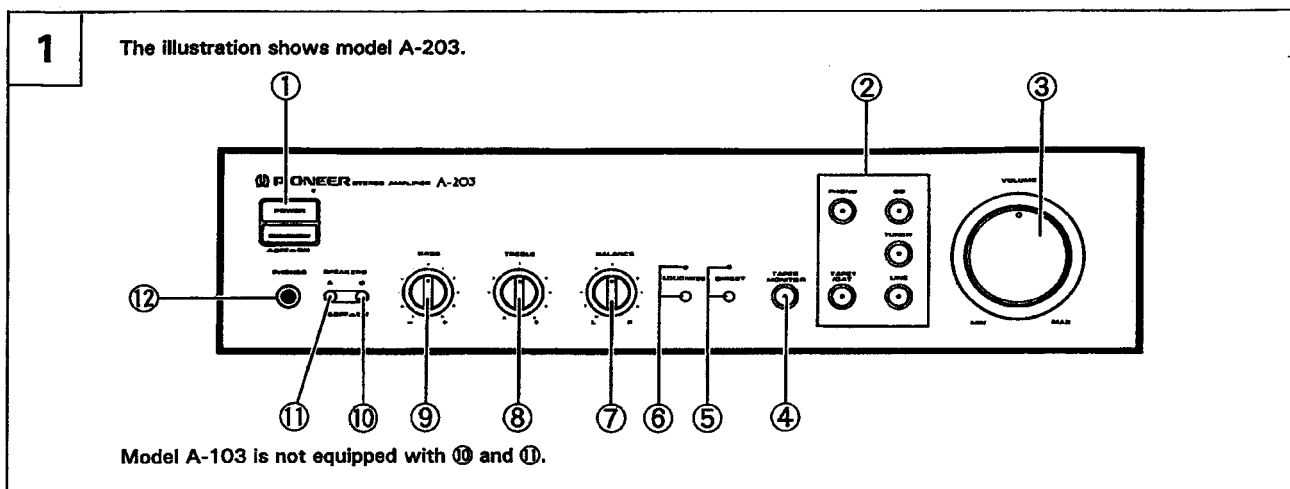

FRONT PANEL

See Fig. **1**

① POWER switch

Press to turn power to the unit ON and OFF.

② Input Selector switch/indicator

Use to select the playback source.

PHONO:

For record playback with a turntable.

CD:

For compact disc playback with a CD player.

TUNER:

For AM or FM broadcast reception with a tuner.

LINE:

Set to this position when listening to the programs from a component connected to the LINE terminals.

TAPE 1/DAT:

For playback with a cassette deck or digital audio tape deck connected to the TAPE 1/DAT terminals.

③ VOLUME control

Use to adjust the volume level.

④ TAPE 2 MONITOR switch/indicator

Use when there is an adaptor component (graphic equalizer, etc.) or cassette deck connected to the TAPE 2 MONITOR terminals.

ON:

Indicator lights when using the adaptor component or listening to the cassette deck.

OFF:

Indicator goes out when not in use.

NOTE:

- When no connections are made to the TAPE 2 MONITOR terminals, or when they are not in use, be sure to set this switch to the OFF position. (No sound will be heard if it is set to the ON position.)
- When the TAPE 2 MONITOR indicator is on and the input selector switch is not set to TAPE 1/DAT, the signals which are input through TAPE 2 MONITOR are then output at TAPE 1/DAT REC OUT.

⑤ DIRECT switch/indicator

Use this switch when you do not wish to pass the output from input terminal equipment through the various frequency adjusting circuits (BASS, TREBLE, BALANCE, LOUDNESS.)

ON:

The indicator lights: The signals input through the input terminals are reproduced without passing through the various frequency adjusting circuits. This results in flat, pure sound which is a more faithful reproduction of the input source.

OFF:

The indicator goes out: The signal passes through the various frequency adjusting circuits.

⑥ MUTING button/indicator (Only U.K. model of A-203)

Use to temporarily cut sound volume.

ON: (Red illumination)

The indicator lights. The sound volume will be reduced -20dB.

OFF:

The indicator goes off. The sound will return to its previous volume.

⑦ LOUDNESS switch/indicator (Except U.K. model of A-203)

Use when listening at low volume levels.

ON:

The indicator lights: Boosts low and high frequencies to give added punch to playback even at low volume levels.

OFF:

The indicator goes off: Should normally be left in this position.

NOTE:

This control does not operate when the DIRECT switch is in the ON position.

⑧ BALANCE control

Should normally be left in the center position. Adjust the balance if the sound is louder from one of the speakers. If the right side is louder, turn toward the L (left) position and if the left side is louder, turn toward the R (right) position.

NOTE:

This control does not operate when the DIRECT switch is in the ON position.

⑧ TREBLE tone control

Use to adjust the high-frequency tone. The center position is the flat (normal) position. When turned to the right, high-frequency tone is emphasized; when turned to the left, high-frequency tone is de-emphasized.

NOTE:

This control does not operate when the DIRECT switch is in the ON position.

⑨ BASS tone control

Use to adjust the low-frequency tone. The center position is the flat (normal) position. When turned to the right, low-frequency tone is emphasized; when turned to the left, low-frequency tone is de-emphasized.

NOTE:

This control does not operate when the DIRECT switch is in the ON position.

⑩ SPEAKERS A selector switch (A-203 only)
Use this switch to listen to the speaker system connected to the SPEAKERS A terminals.

ON (●):

Depressed position: Sound is heard from the speaker system.

OFF (○):

Released position: No sound is heard from the speaker system. Set to this position when listening with headphones

⑪ SPEAKERS A selector switch (A-203 only)

Use this switch to listen to the speaker system connected to the SPEAKERS A terminals.

ON (●):

Depressed position: Sound is heard from the speaker system.

OFF (○):

Released position: No sound is heard from the speaker system. Set to this position when listening with headphones.

⑫ PHONES jack

When using headphones, insert the plug into this jack.

With model A-103 the output to the speakers is cut automatically when connecting headphones.

10. SPECIFICATIONS

[A-203]

Amplifier Section

Continuous power output
(both channels driven at 20 Hz to 20 kHz)**

T.H.D. 0.07 %, 8 Ω	35 W + 35 W*
T.H.D. 0.1 %, 4 Ω	40 W + 40 W*

DIN Continuous power output (both channels driven at 1 kHz)

T.H.D. 1.0 %, 8 Ω	45 W + 45 W
T.H.D. 1.0 %, 4 Ω	55 W + 55 W

Dynamic power output (E.I.A. test signal)

4 Ω	66 W
-----	------

Total harmonic distortion**

20 Hz to 20 kHz, 17,5 W, 8 Ω	0.05 %*
------------------------------	---------

* Above specifications are for when power supply is 230 V.

Input sensitivity/impedance

PHONO (MM)	2.8 mV/50 kΩ
CD, TUNER, LINE, TAPE 1/DAT, TAPE 2 MONITOR	200 mV/50 kΩ

PHONO overload level

1 kHz, T.H.D. 0.1 % (MM)	150 mV
--------------------------	--------

Output level/impedance

TAPE REC, ADPT OUT	200 mV/1 kΩ
--------------------	-------------

Frequency response

PHONO (MM)	20 Hz to 20 kHz ±0.5 dB
CD, TUNER, LINE, TAPE 1/DAT, TAPE 2 MONITOR,	5 Hz to 100 kHz ±2 dB*

Tone control

BASS	± 8 dB (100 Hz)
TREBLE	± 8 dB (10 kHz)

Loudness contour (volume control set at -30 dB position)

Australian model only	+5 dB (100 Hz)/+3 dB (10 kHz)
-----------------------	-------------------------------

Signal-to-Noise ratio (IHF short circuit, A network)

PHONO (MM, 5 mV input)	82 dB*
CD, TUNER, LINE, TAPE 1/DAT, TAPE 2 MONITOR	105 dB*

Signal-to-Noise ratio (DIN, continuous power/50 mW)

PHONO (MM)	68 dB/64 dB*
CD, TUNER, LINE, TAPE 1/DAT, TAPE 2 MONITOR	85 dB/67 dB*

Power Supply/Miscellaneous

Power requirements	AC 220 - 230 Volts, 50/60 Hz
Power consumption	330 W
Dimensions (including knobs and other protruding parts)	420 (W) × 312 (D) × 110 (H) mm
Weight (without package)	5.2 kg

Accessories

Operating instructions	1
------------------------	---

NOTE:

Specifications and design subject to possible modification without notice, due to improvements.

* Measured with the DIRECT switch set to ON.

** Measured by Audio Spectrum Analyzer.

[A-103]

Amplifier Section

Continuous power output
(both channels driven at 20 Hz to 20 kHz)**

T.H.D. 0.1 %, 8 Ω	25 W + 25 W*
-------------------	--------------

DIN Continuous power output (both channels driven at 1 kHz)

T.H.D. 1.0 %, 8 Ω	30 W + 30 W
-------------------	-------------

Total harmonic distortion**

20 Hz to 20 kHz, 12,5 W, 8 Ω	0.05 %*
------------------------------	---------

* Above specifications are for when power supply is 230 V.

Input sensitivity/impedance

PHONO (MM)	2.8 mV/50 kΩ
CD, TUNER, LINE, TAPE 1/DAT, TAPE 2 MONITOR	200 mV/50 kΩ

PHONO overload level

1 kHz, T.H.D. 0.1 % (MM)	150 mV
--------------------------	--------

Output level/impedance

TAPE REC, ADPT OUT	200 mV/1 kΩ
--------------------	-------------

Frequency response

PHONO (MM)	20 Hz to 20 kHz ±0.5 dB
CD, TUNER, LINE, TAPE 1/DAT, TAPE 2 MONITOR,	5 Hz to 100 kHz ±2 dB*

Tone control

BASS	± 8 dB (100 Hz)
TREBLE	± 8 dB (10 kHz)

Loudness contour (volume control set at -30 dB position)

Australian model only	+5 dB (100 Hz)/+3 dB (10 kHz)
-----------------------	-------------------------------

Signal-to-Noise ratio (IHF short circuit, A network)

PHONO (MM, 5 mV input)	82 dB*
CD, TUNER, LINE, TAPE 1/DAT, TAPE 2 MONITOR	105 dB*

Signal-to-Noise ratio (DIN, continuous power/50 mW)

PHONO (MM)	68 dB/64 dB*
CD, TUNER, LINE, TAPE 1/DAT, TAPE 2 MONITOR	85 dB/67 dB*

Power Supply/Miscellaneous

Power requirements	AC 220 - 230 Volts, 50/60 Hz
Power consumption	210 W
Dimensions (including knobs and other protruding parts)	420 (W) × 312 (D) × 110 (H) mm
Weight (without package)	4,2 kg

Accessories

Operating instructions	1
------------------------	---

NOTE:

Specifications and design subject to possible modification without notice, due to improvements.

* Measured with the DIRECT switch set to ON.

** Measured by Audio Spectrum Analyzer.