

Service Manual

Pioneer

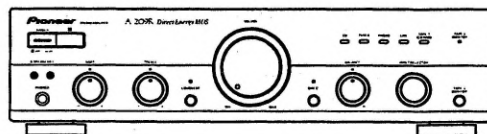

ORDER NO.
RRV2283

STEREO AMPLIFIER

A-209R

A-209

THIS MANUAL IS APPLICABLE TO THE FOLLOWING MODEL(S) AND TYPE(S).

Type	Model		Power Requirement	The voltage can be converted by the following method.
	A-209R	A-209		
MYXJ	○	-	AC220-230V	_____
MVXJ	○	-	AC220-230V	_____
MLXJ	-	○	AC220-230V	_____
SBDXJ	-	○	AC110V/120-127V/220V/240V	With the voltage selector

CONTENTS

1. SAFETY INFORMATION	2	7. GENERAL INFORMATION	28
2. EXPLODED VIEWS AND PARTS LIST	3	7.1 DISASSEMBLY	28
3. BLOCK DIAGRAM AND SCHEMATIC DIAGRAM	6	7.2 IC	29
4. PCB CONNECTION DIAGRAM	16	8. PANEL FACILITIES AND SPECIFICATIONS	30
5. PCB PARTS LIST	24		
6. ADJUSTMENT	27		

PIONEER CORPORATION 4-1, Meguro 1-chome, Meguro-ku, Tokyo 153-8654, Japan
PIONEER ELECTRONICS SERVICE, INC. P.O. Box 1760, Long Beach, CA 90801-1760, U.S.A.
PIONEER EUROPE N.V. Haven 1087, Keetberglaan 1, 9120 Melsele, Belgium
PIONEER ELECTRONICS ASIACENTRE PTE. LTD. 253 Alexandra Road, #04-01, Singapore 159936
 ©PIONEER CORPORATION 2000

1. SAFETY INFORMATION

This service manual is intended for qualified service technicians ; it is not meant for the casual do-it-yourselfer. Qualified technicians have the necessary test equipment and tools, and have been trained to properly and safely repair complex products such as those covered by this manual. Improperly performed repairs can adversely affect the safety and reliability of the product and may void the warranty. If you are not qualified to perform the repair of this product properly and safely, you should not risk trying to do so and refer the repair to a qualified service technician.



WARNING

This product contains lead in solder and certain electrical parts contain chemicals which are known to the state of California to cause cancer, birth defects or other reproductive harm.

Health & Safety Code Section 25249.6 – Proposition 65



NOTICE

(FOR CANADIAN MODEL ONLY)

Fuse symbols  (fast operating fuse) and/or  (slow operating fuse) on PCB indicate that replacement parts must be of identical designation.

REMARQUE

(POUR MODÈLE CANADIEN SEULEMENT)

Les symboles de fusible  (fusible de type rapide) et/ou  (fusible de type lent) sur CCI indiquent que les pièces de remplacement doivent avoir la même désignation.

(FOR USA MODEL ONLY)

1. SAFETY PRECAUTIONS

The following check should be performed for the continued protection of the customer and service technician.

LEAKAGE CURRENT CHECK

Measure leakage current to a known earth ground (water pipe, conduit, etc.) by connecting a leakage current tester such as Simpson Model 229-2 or equivalent between the earth ground and all exposed metal parts of the appliance (input/output terminals, screwheads, metal overlays, control shaft, etc.). Plug the AC line cord of the appliance directly into a 120V AC 60Hz outlet and turn the AC power switch on. Any current measured must not exceed 0.5mA.

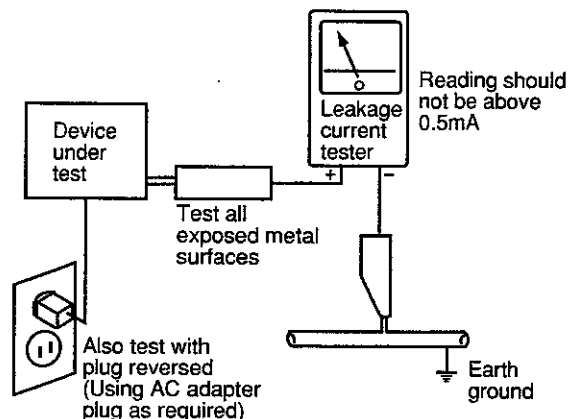

AC Leakage Test

ANY MEASUREMENTS NOT WITHIN THE LIMITS OUTLINED ABOVE ARE INDICATIVE OF A POTENTIAL SHOCK HAZARD AND MUST BE CORRECTED BEFORE RETURNING THE APPLIANCE TO THE CUSTOMER.

2. PRODUCT SAFETY NOTICE

Many electrical and mechanical parts in the appliance have special safety related characteristics. These are often not evident from visual inspection nor the protection afforded by them necessarily can be obtained by using replacement components rated for voltage, wattage, etc. Replacement parts which have these special safety characteristics are identified in this Service Manual.

Electrical components having such features are identified by marking with a Δ on the schematics and on the parts list in this Service Manual.

The use of a substitute replacement component which does not have the same safety characteristics as the PIONEER recommended replacement one, shown in the parts list in this Service Manual, may create shock, fire, or other hazards.

Product Safety is continuously under review and new instructions are issued from time to time. For the latest information, always consult the current PIONEER Service Manual. A subscription to, or additional copies of, PIONEER Service Manual may be obtained at a nominal charge from PIONEER.

2. EXPLODED VIEWS AND PARTS LIST

- NOTES: ● Parts marked by "NSP" are generally unavailable because they are not in our Master Spare Parts List.
 ● The Δ mark found on some component parts indicates the importance of the safety factor of the part. Therefore, when replacing, be sure to use parts of identical designation.
 ● Screws adjacent to ∇ mark on the product are used for disassembly.

2.1 PACKING

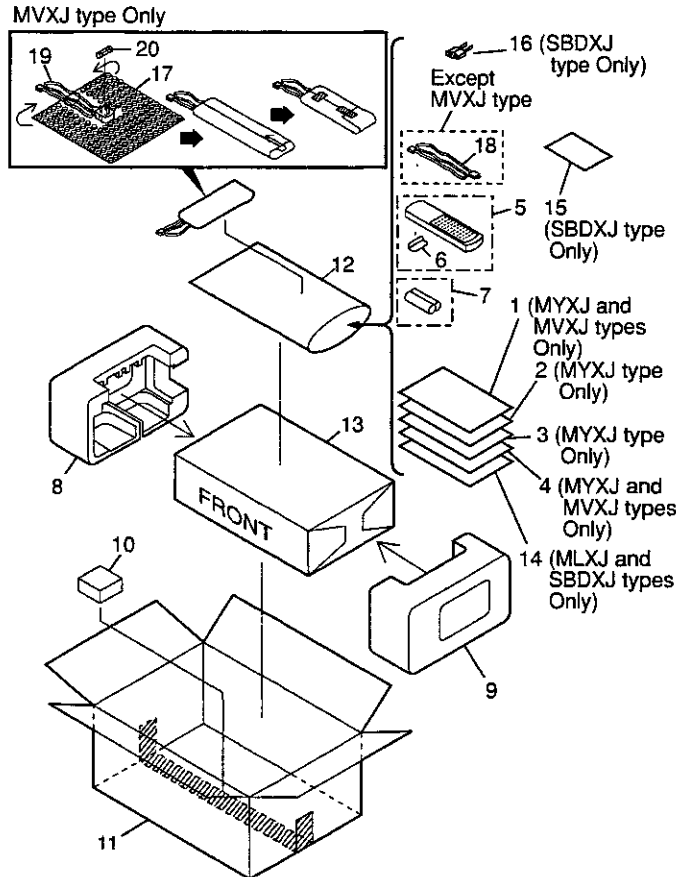

(1) PACKING PARTS LIST

Mark	No.	Description	Part No.
	1	Operating Instructions (English)	See Contrast table(2)
	2	Operating Instructions (German)	See Contrast table(2)
	3	Operating Instructions (French/Italian/Dutch/Swedish/Spanish/Portugese)	See Contrast table(2)
NSP	4	Warranty Card	See Contrast table(2)
	5	Remote Control Unit (CU-A019)	See Contrast table(2)
NSP	6	Battery Cover	See Contrast table(2)
	7	Dry Cell Battery (AA/R6P)	See Contrast table(2)
	8	Side Pad L	AHA7205
	9	Side Pad R	AHA7206
	10	Sub Pad	AHA7218
NSP	11	Packing Case	See Contrast table(2)
	12	Literature Bag	AHG1180
	13	Packing Sheet	AHG7015
	14	Operating Instructions (English/Spanish/Chinese)	See Contrast table(2)
	15	Caution Label 220V	See Contrast table(2)
NSP	16	AC Plug Adapter	See Contrast table(2)
	17	Air Cap	See Contrast table(2)
	Δ	18 Power Cord	See Contrast table(2)
	Δ	19 Power Cord with Fuse	See Contrast table(2)
	Δ	20 Fuse (T5A)	See Contrast table(2)

(2) CONTRAST TABLE

A-209R/MYXJ, MVXJ, A-209/MLXJ and SBDXJ are constructed the same except for the following :

Mark	No.	Symbol and Description	Part No.				Remarks
			A-209R /MYXJ	A-209R /MVXJ	A-209 /MLXJ	A-209 /SBDXJ	
NSP	1	Operating Instructions (English)	ARB7236	ARB7236	Not used	Not used	
	2	Operating Instructions (German)	ARC7322	Not used	Not used	Not used	
	3	Operating Instructions (French/Italian/Dutch/Swedish/Spanish/Portuguese)	ARC7323	Not used	Not used	Not used	
NSP	4	Warranty Card	ARY7022	ARY7022	Not used	Not used	
NSP	5	Remote Control Unit (CU-A019)	AXD7193	AXD7193	Not used	Not used	
	6	Battery Cover	AZN2249	AZN2249	Not used	Not used	
	7	Dry Cell Battery (AA/R6P)	VEM-013	VEM-013	Not used	Not used	
NSP	11	Packing Case	AHD7869	AHD7869	AHD7870	AHD7891	
	14	Operating Instructions (English/Spanish/Chinese)	Not used	Not used	ARE7269	ARE7269	
	15	Caution Label 220V	Not used	Not used	Not used	ARR1003	
NSP	16	AC Plug Adapter	Not used	Not used	Not used	VKX1007	
	17	Air Cap	Not used	AHG1087	Not used	Not used	
	Δ	18 Power Cord	ADG1154	Not used	ADG1154	ADG1154	
Δ	19	Power Cord with Fuse	Not used	ADG1156	Not used	Not used	
Δ	20	Fuse (T5A)	Not used	AEK1046	Not used	Not used	

A-209R, A-209

2.2 EXTERIOR

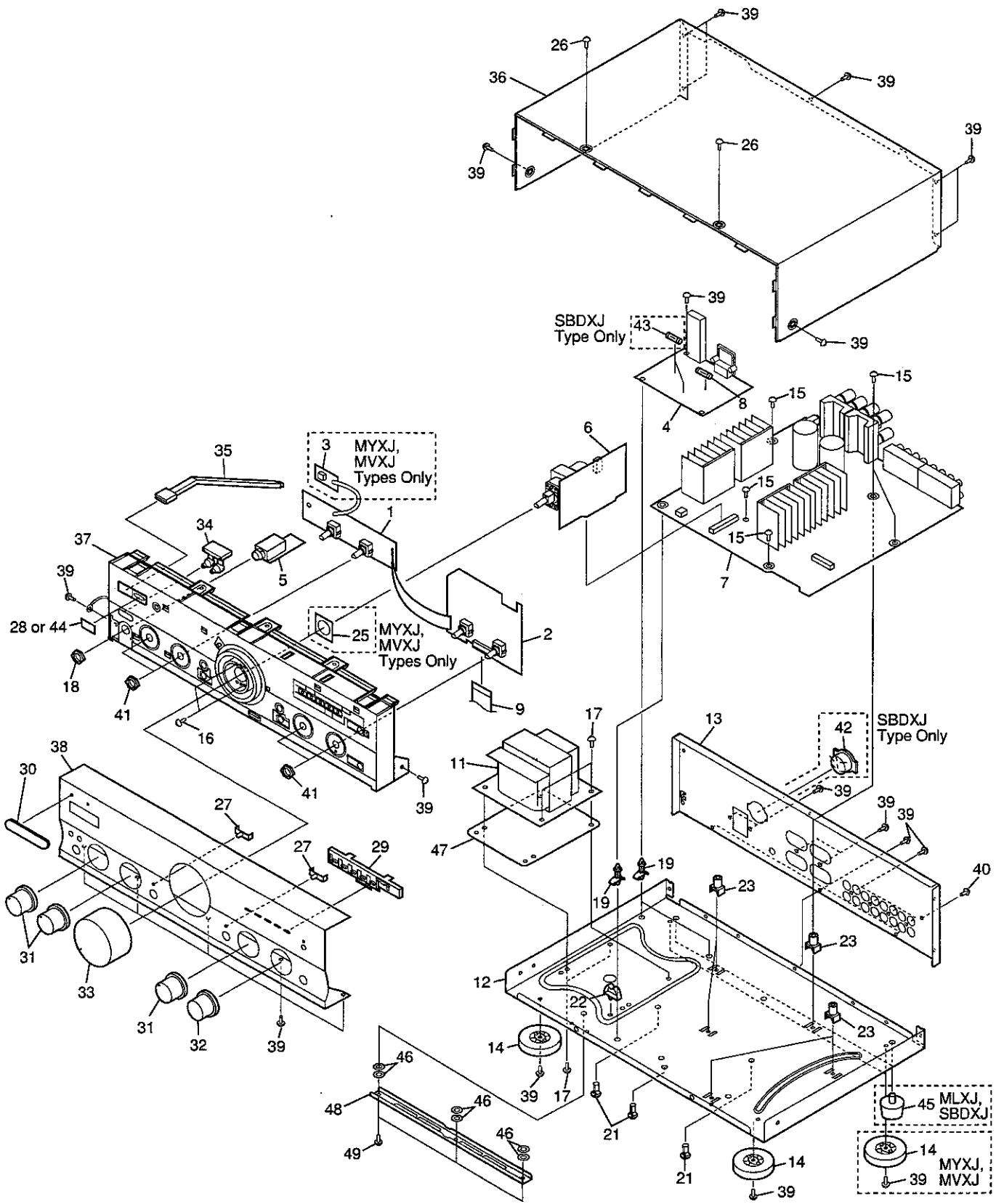

(1) EXTERIOR PARTS LIST

Mark	No.	Description	Part No.	Mark	No.	Description	Part No.
	1	FRONT L Assy	See Contrast table(2)		26	Screw (3 × 8)	PBA1096
	2	FRONT R Assy	See Contrast table(2)		27	LED Lens	AAK2459
	3	OPT Assy	See Contrast table(2)		28	IR Filter	See Contrast table(2)
	4	AC PRIMARY Assy	See Contrast table(2)		29	LED Lens A	AAK7537
NSP	5	HEADPHONE Assy	AWX7114		30	Name Plate	PAM1776
	6	VOLUME Assy	See Contrast table(2)		31	Rotary Knob A	AAB7148
	7	AF Assy	See Contrast table(2)		32	Rotary Knob B	AAB7149
Δ	8	Fuse (FU1)	See Contrast table(2)		33	Volume Knob	AAB7150
	9	Flexible Cable (19P) (AF CN202-FRONT R CN601)	ADD7032		34	Speaker Button	AAD7435
	10	*****			35	Power Joint	AAD7439
Δ	11	Power Transformer (T1)	See Contrast table(2)		36	Bonnet Case	ANE7183
NSP	12	Chassis	ANA7064		37	Panel Base	AMB7489
	13	Rear Panel	See Contrast table(2)		38	Front Panel	See Contrast table(2)
	14	Insulator	See Contrast table(2)		39	Screw	BBZ30P080FZK
	15	Screw (3 × 8)	ABA1018		40	Screw	BCZ30P060FCC
	16	Screw (3 × 8)	ABA1027		41	Nut	NK90FUC
	17	Screw (4 × 10)	ABA7047	Δ	42	Voltage Selector (S2)	See Contrast table(2)
	18	Nut	ABN-065	Δ	43	Fuse (FU2, FU3 : 1.25A)	See Contrast table(2)
	19	PCB Support	AEC7006		44	PVC Cover	See Contrast table(2)
	20	*****			45	Foot	See Contrast table(2)
NSP	21	PCB Holder	AEC7057		46	Spacer	ABF7004
NSP	22	Cord Clamp F	AEC7134		47	Transformer Plate	ANG7312
	23	PCB Mold	AMR2533	NSP	48	Sub Frame	ANG7313
	24	*****			49	Screw	IBZ30P120FCC
NSP	25	Shield Plate	See Contrast table(2)				

(2) CONTRAST TABLE

A-209R/MYXJ, MVXJ, A-209/MLXJ and SBDXJ are constructed the same except for the following :

Mark	No.	Symbol and Description	Part No.				Remarks
			A-209R /MYXJ	A-209R /MVXJ	A-209 /MLXJ	A-209 /SBDXJ	
	1	FRONT L Assy	AWX7123	AWX7123	AWX7122	AWX7122	
	2	FRONT R Assy	AWX7124	AWX7124	AWX7121	AWX7121	
	3	OPT Assy	AWX7125	AWX7125	Not used	Not used	
	4	AC PRIMARY Assy	AWX7113	AWX7113	AWX7113	AWX7670	
	6	VOLUME Assy	AWX7118	AWX7118	AWX7112	AWX7112	
	7	AF Assy	AWX7117	AWX7117	AWX7116	AWX7116	
Δ	8	Fuse (FU1 : 1.25A)	REK1023	REK1023	REK1023	Not used	
Δ	8	Fuse (FU1 : 6.3A)	Not used	Not used	Not used	REK1030	
Δ	11	Power Transformer (AC220-230V)	ATS7190	ATS7190	ATS7190	Not used	
Δ	11	Power Transformer (AC110V/120-127V/220V/240V)	Not used	Not used	Not used	ATS7191	
	13	Rear Panel	ANC7925	ANC7925	ANC7927	ANC7928	
	14	Insulator	PNW2766	PNW2766	AMR7198	AMR7198	
NSP	25	Shield Plate	ANK7043	ANK7043	Not used	Not used	
	28	IR Filter	AAK7532	AAK7532	Not used	Not used	
	38	Front Panel	AMB7710	AMB7710	AMB7711	AMB7711	
Δ	42	Voltage Selector (S2)	Not used	Not used	Not used	AKX-507	
Δ	43	Fuse (FU2, FU3 : 1.25A)	Not used	Not used	Not used	REK1023	
	44	PVC Cover	Not used	Not used	AAK7541	AAK7541	
	45	Foot	Not used	Not used	REC1263	REC1263	

3. BLOCK DIAGRAM AND SCHEMATIC DIAGRAM

3.1 BLOCK DIAGRAM

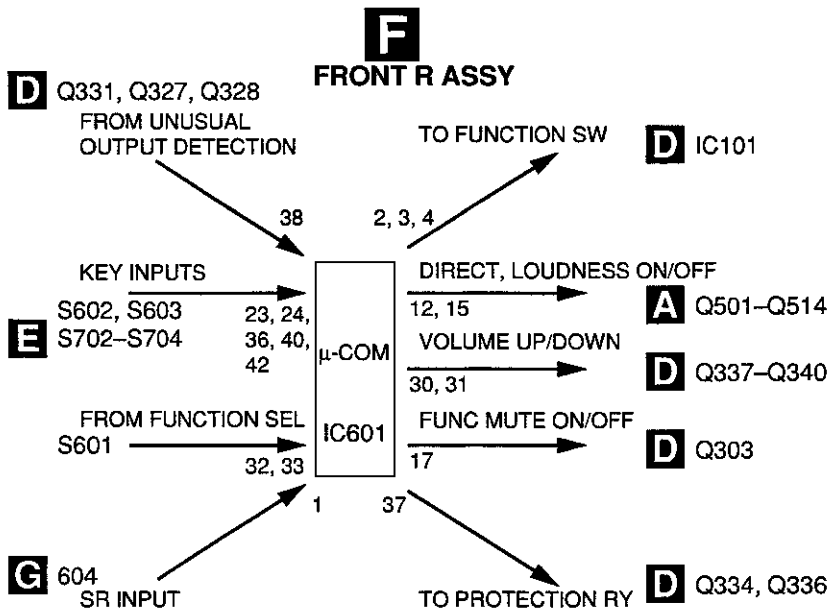
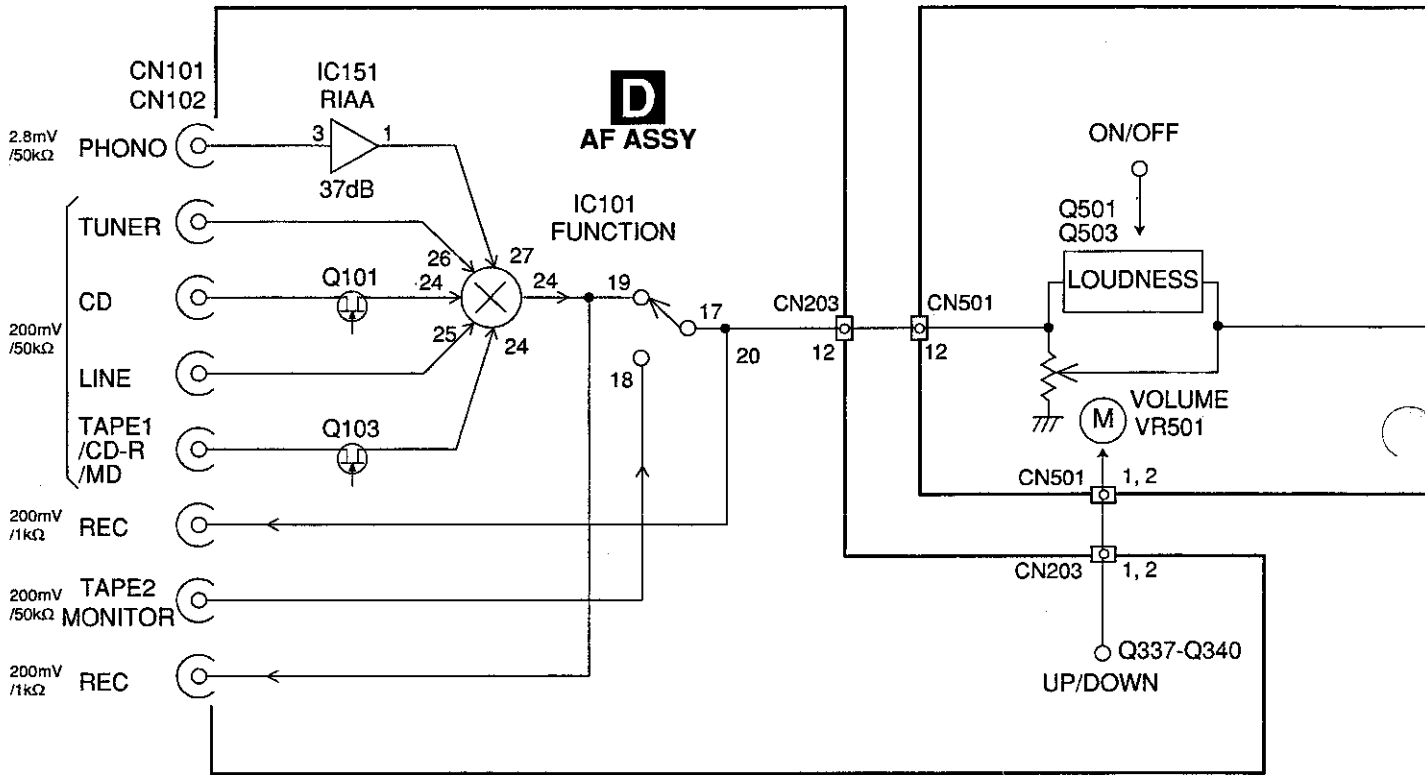

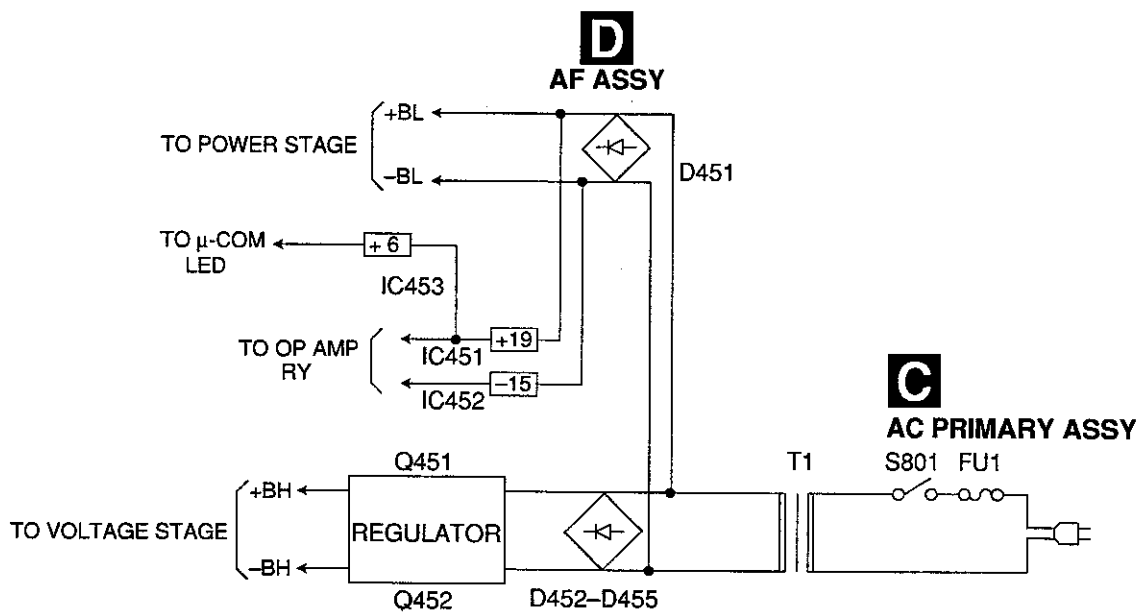
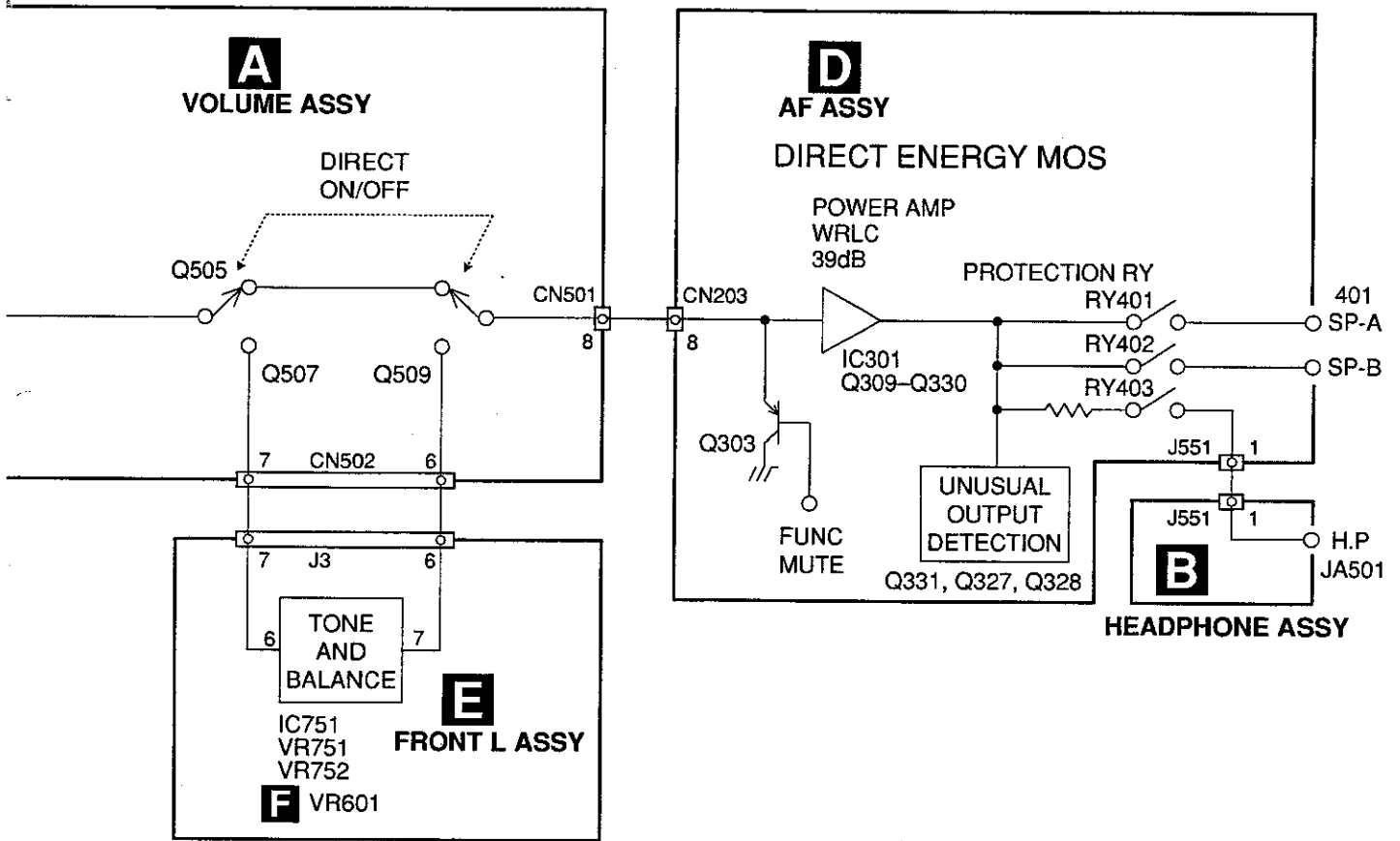

3.2 OVERALL CONNECTION DIAGRAM

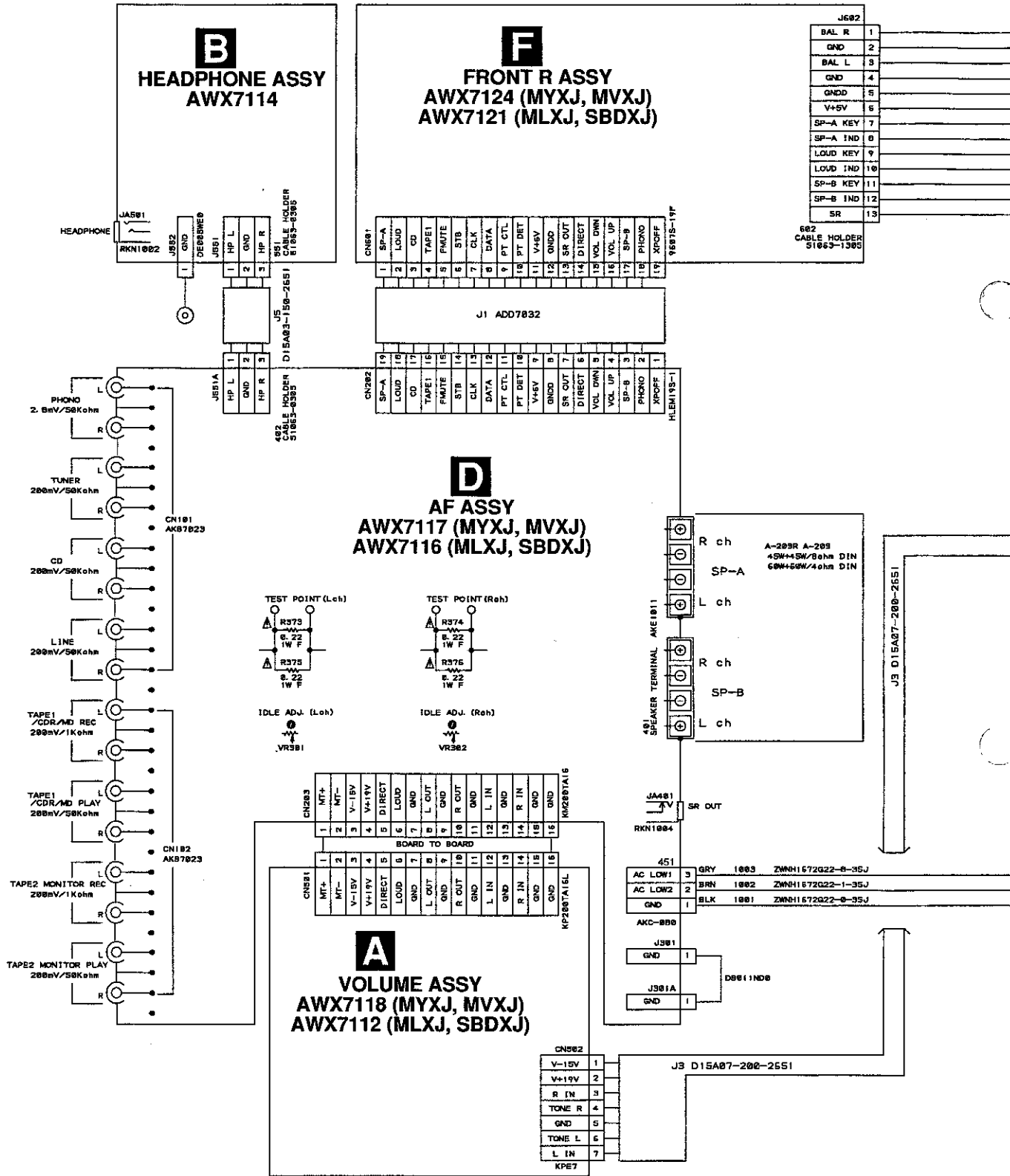

Note : When ordering service parts, be sure to refer to "EXPLODED VIEWS and PARTS LIST" or "PCB PARTS LIST".

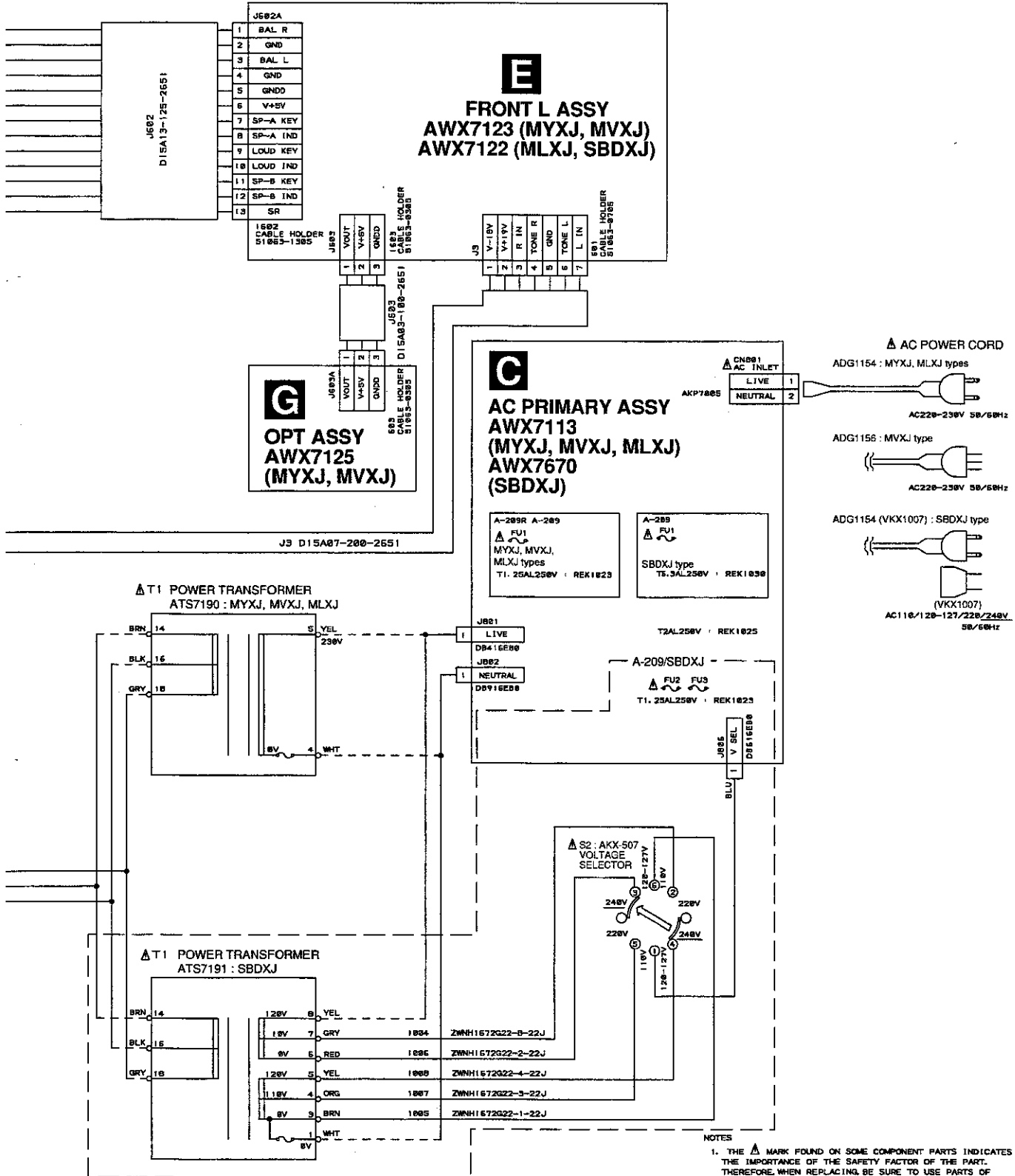

3.3 VOLUME and HEADPHONE ASSYS

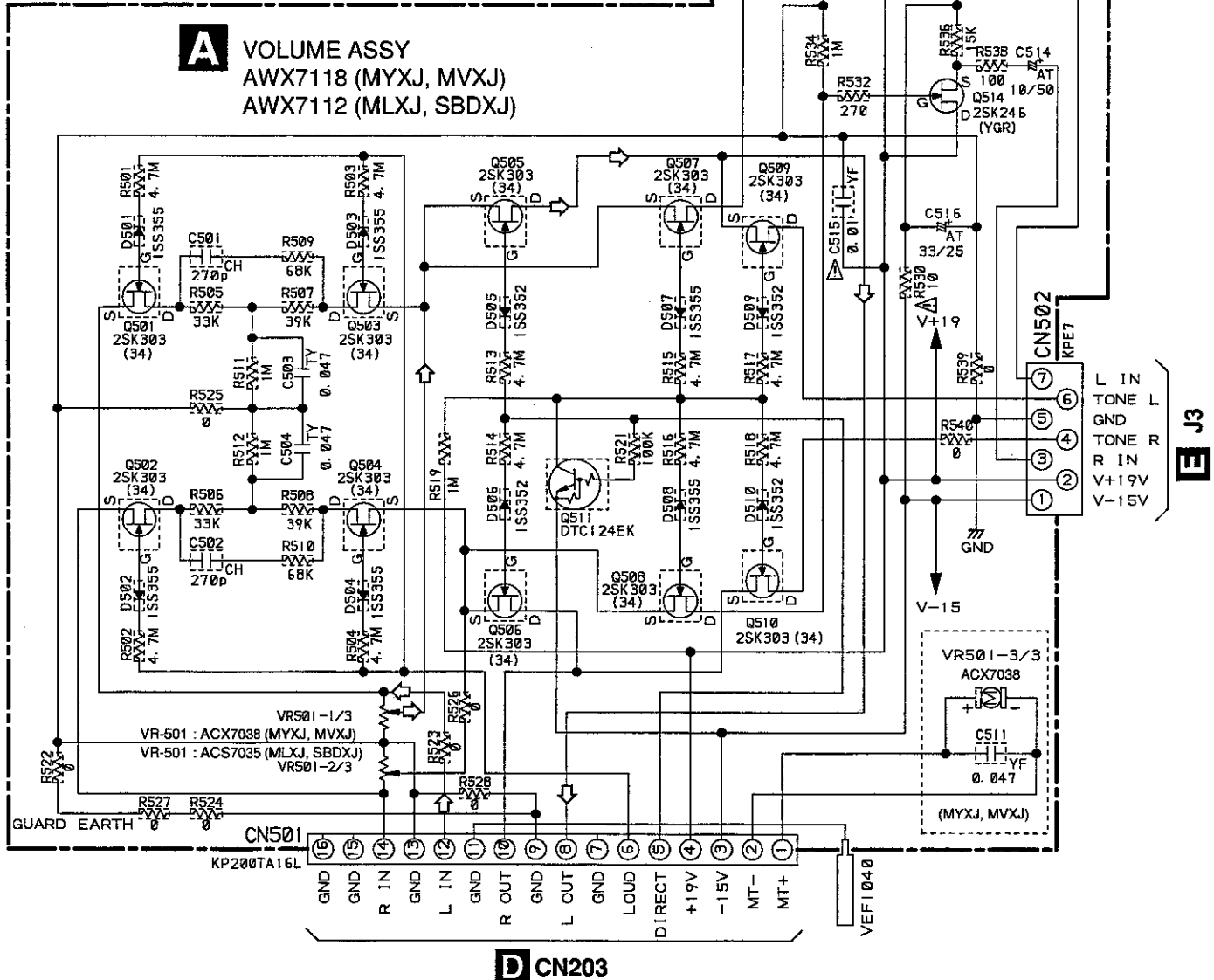
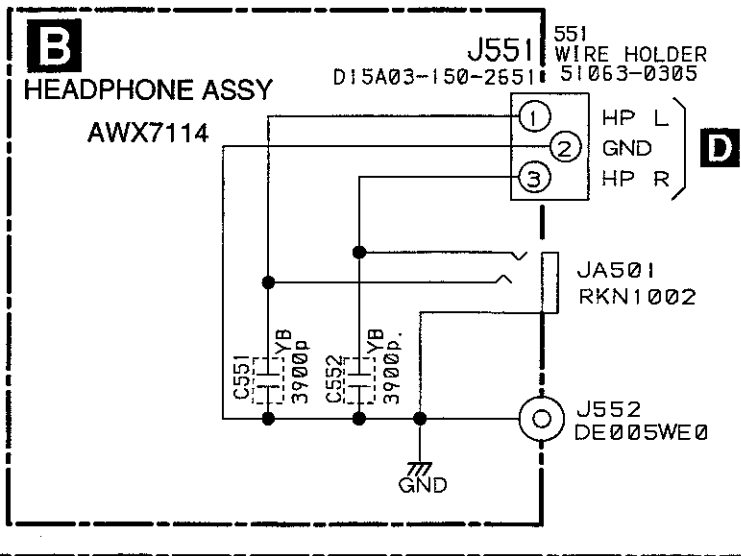

3.4 AC PRIMARY ASSY

• NOTE FOR FUSE REPLACEMENT

CAUTION -FOR CONTINUED PROTECTION AGAINST RISK OF FIRE, REPLACE WITH SAME TYPE AND RATINGS ONLY.

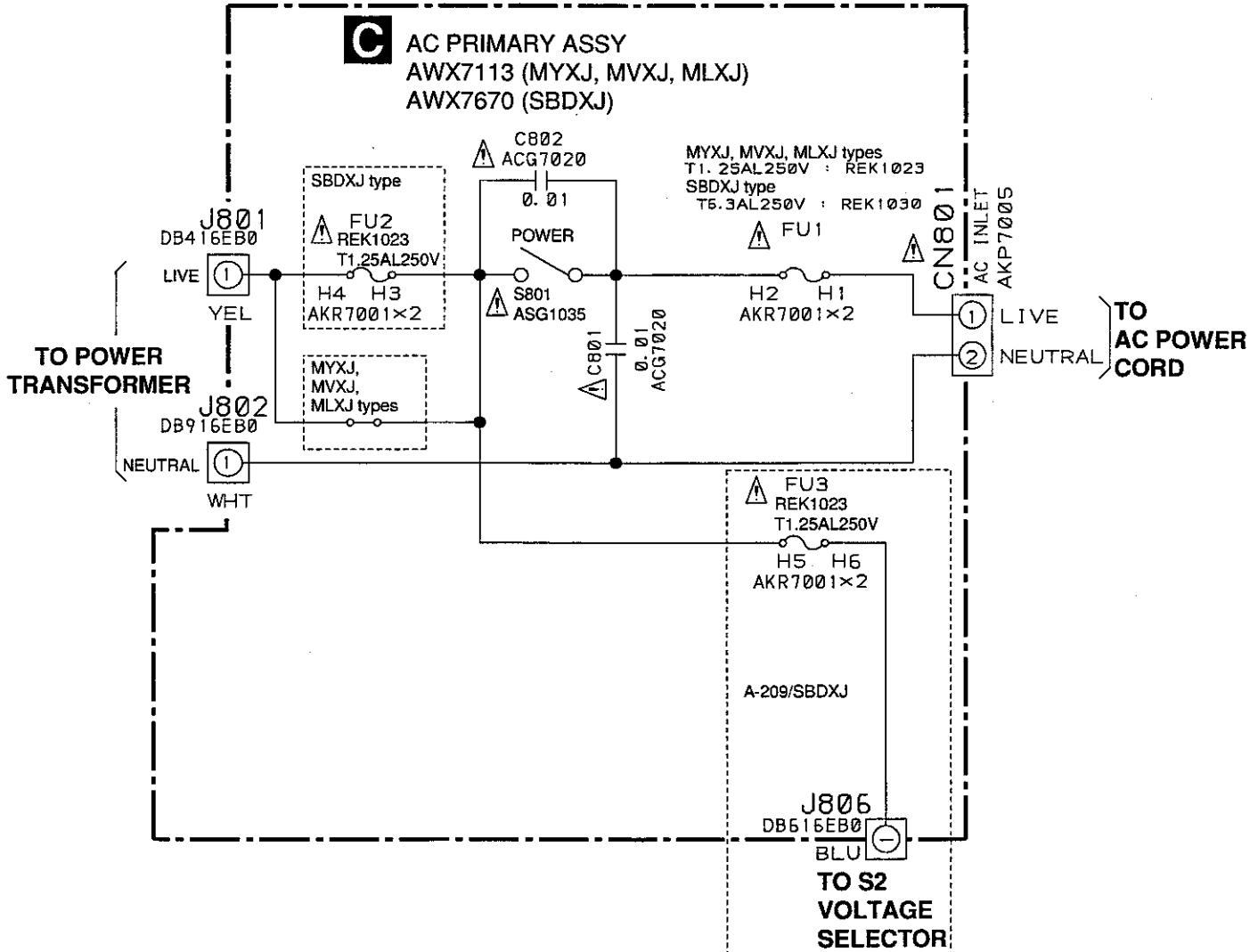

NOTES

1. RESISTORS
INDICATED IN Ohm 1/10W 5% TOLERANCE UNLESS OTHERWISE NOTED
k : kOhm, M : MOhm
2. CAPACITORS
INDICATED IN CAPACITY (uF) /VOLTAGE (V) UNLESS OTHERWISE NOTED p : pF
INDICATED WITHOUT VOLTAGE IS 50V EXCEPT ELECTROLYTIC CAPACITOR.
TY : CFTYA, CH : CCSQCH, YB : CKSQYB, YF : CKSQYF
3. THE Δ MARK FOUND ON SOME COMPONENT PARTS INDICATES THE IMPORTANCE OF THE SAFETY FACTOR OF THE PART. THEREFORE, WHEN REPLACING, BE SURE TO USE PARTS OF IDENTICAL DESIGNATION.

3.5 AF ASSY

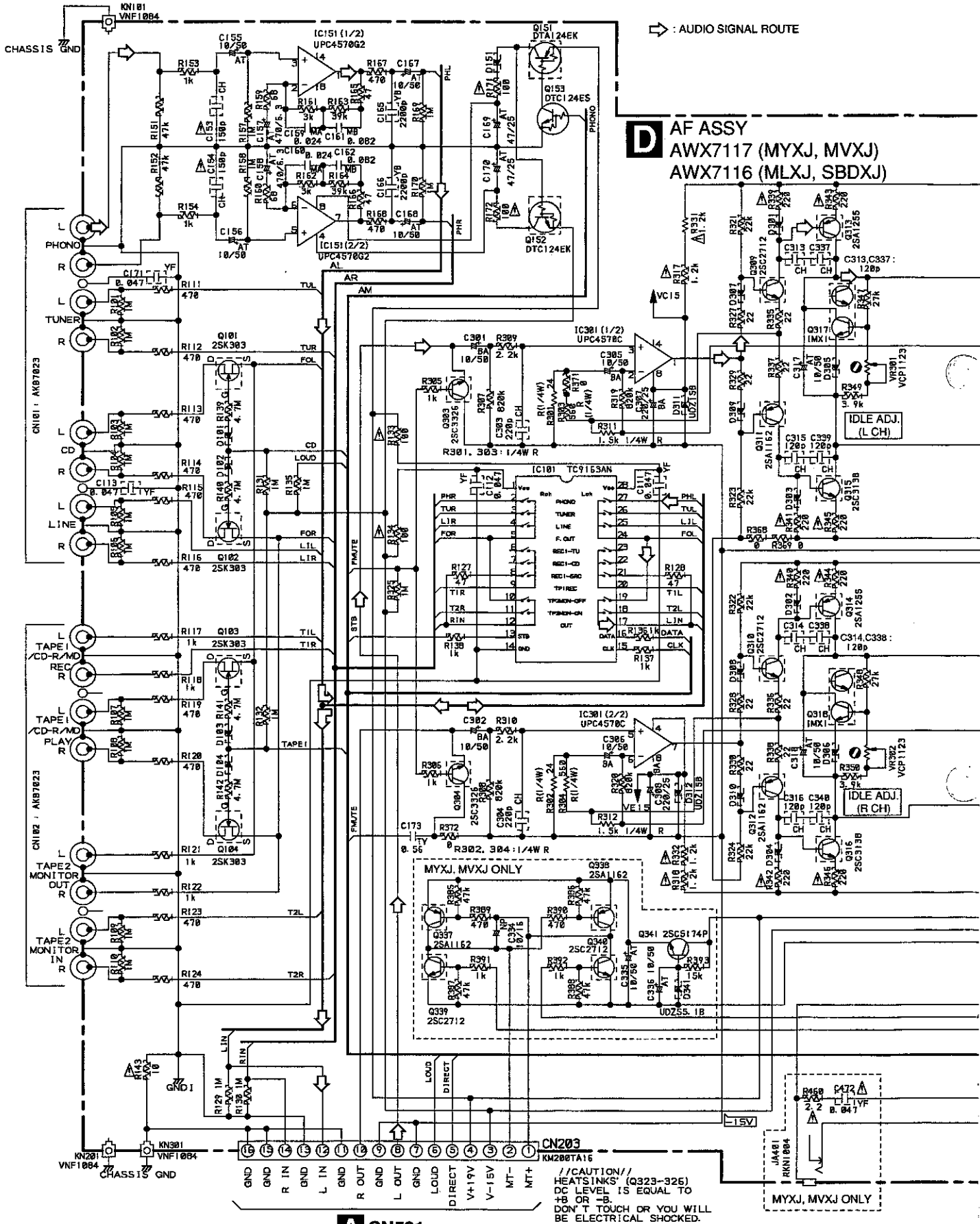

D AF ASSY
 AWX7117 (MYXJ, MVXJ)
 AWX7116 (MLXJ, SBDXJ)

A CN501



NOTES

1. RESISTORS INDICATED IN OHM 1/10W ±5% TOLERANCE UNLESS OTHERWISE NOTED k=1000, M=10000, F=NON-FRAGILE TYPE, R=RDR TYPE

2. CAPACITORS INDICATED IN CAPACITY (UF) /VOLTAGE (V) UNLESS OTHERWISE NOTED 0.1=100PF INDICATED WITHOUT VOLTAGE IS 50V EXCEPT ELECTROLYTIC CAPACITOR. MA=50MA, MB=100MA, TY=CFMY, CH=CC50CH, SL=CC50SL, YB=CK50YB, YF=CK50YF

3. INDUCTORS INDICATED IN H ±5%

4. DIODES NO MARK DIODES ARE 1SS955

5. VOLTAGE INDICATED IN DC VOLTAGE-NO SIGNAL (DIN POWER OUTPUT (A=0.31 NO SIGNAL /0.04W/200 400Hz)) 5. THE Δ MARK FOUND ON SOME COMPONENT PARTS INDICATES THE IMPORTANCE OF THE SAFETY FACTOR OF THE PART IDENTIFICATION. BE SURE TO USE PARTS OF IDENTICAL DESIGNATION.

7. TRANSISTOR'S RANK 25C3138: (OY) 25C2712: (OY) 25C3325: (AB) 25A1255: (OY) 25A1152: (OY) 28K383: (34)

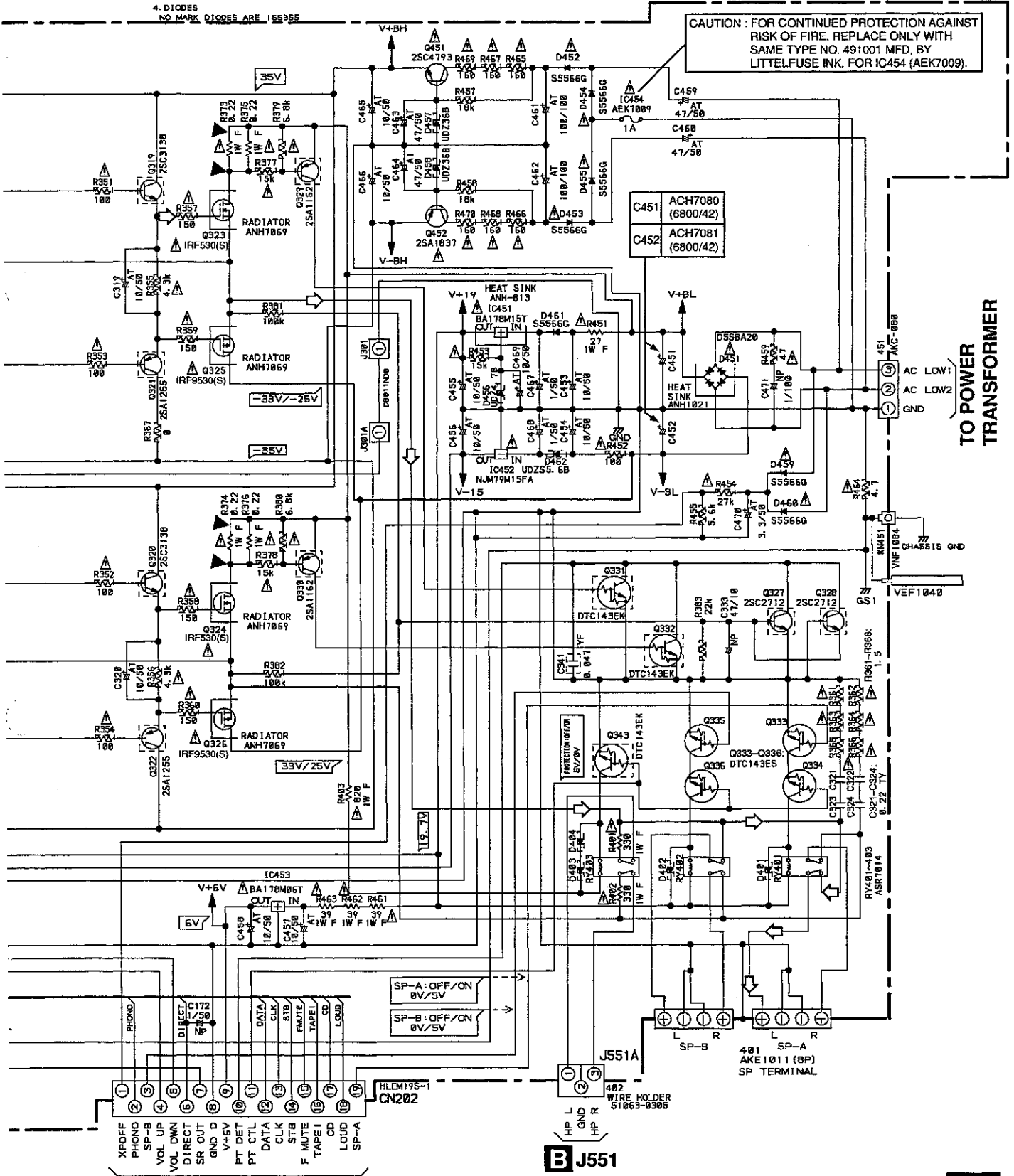

CAUTION: FOR CONTINUED PROTECTION AGAINST RISK OF FIRE, REPLACE ONLY WITH SAME TYPE NO. 491001 MFD, BY LITTELFUSE INC. FOR IC454 (AEK7009).

TO POWER TRANSFORMER

F CN601

B J551

D

3.6 FRON L, FRONT R and OPT ASSYS

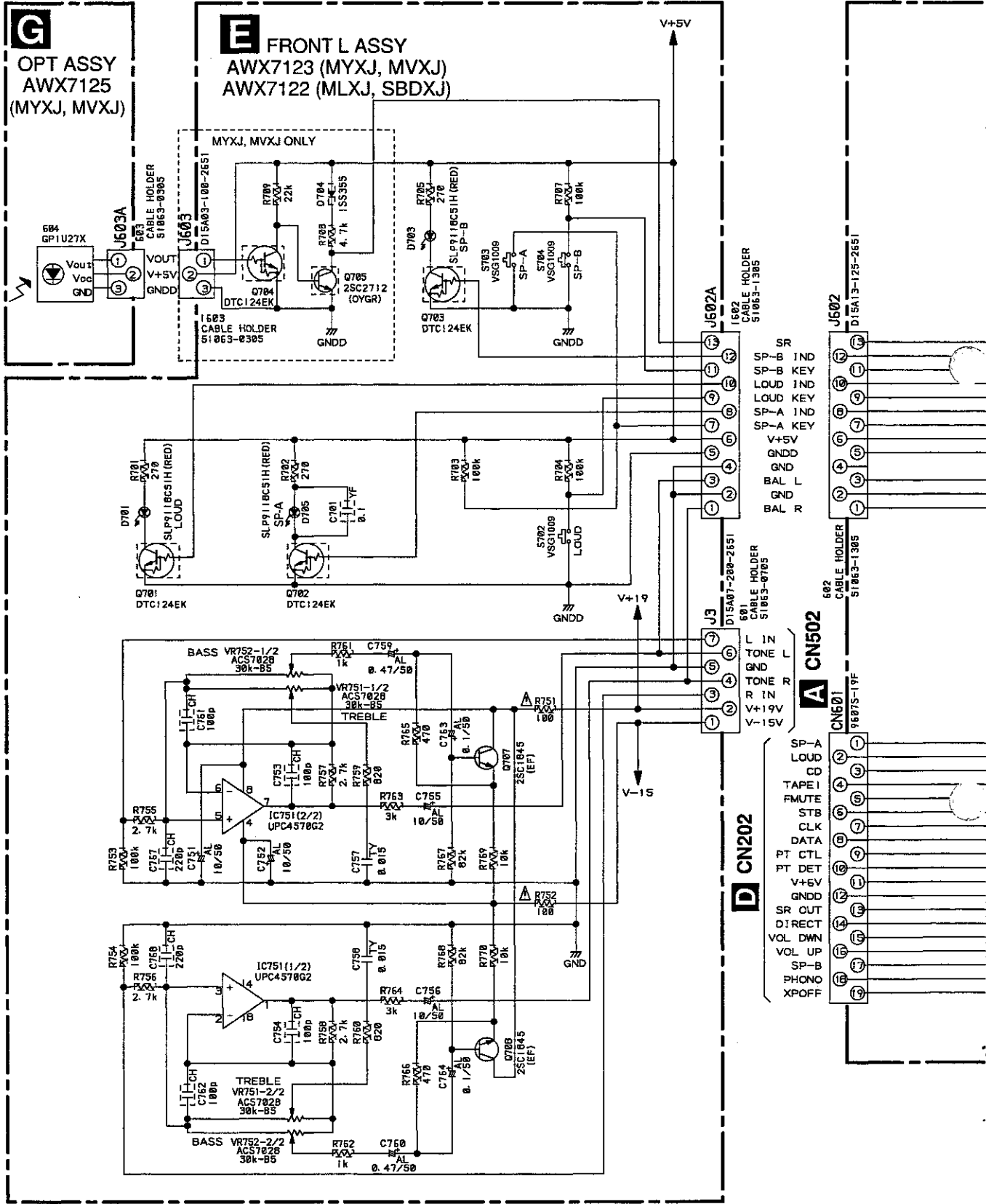

FRONT L ASSY
S702 : LOUDNESS
S703 : SPEAKER A
S704 : SPEAKER B

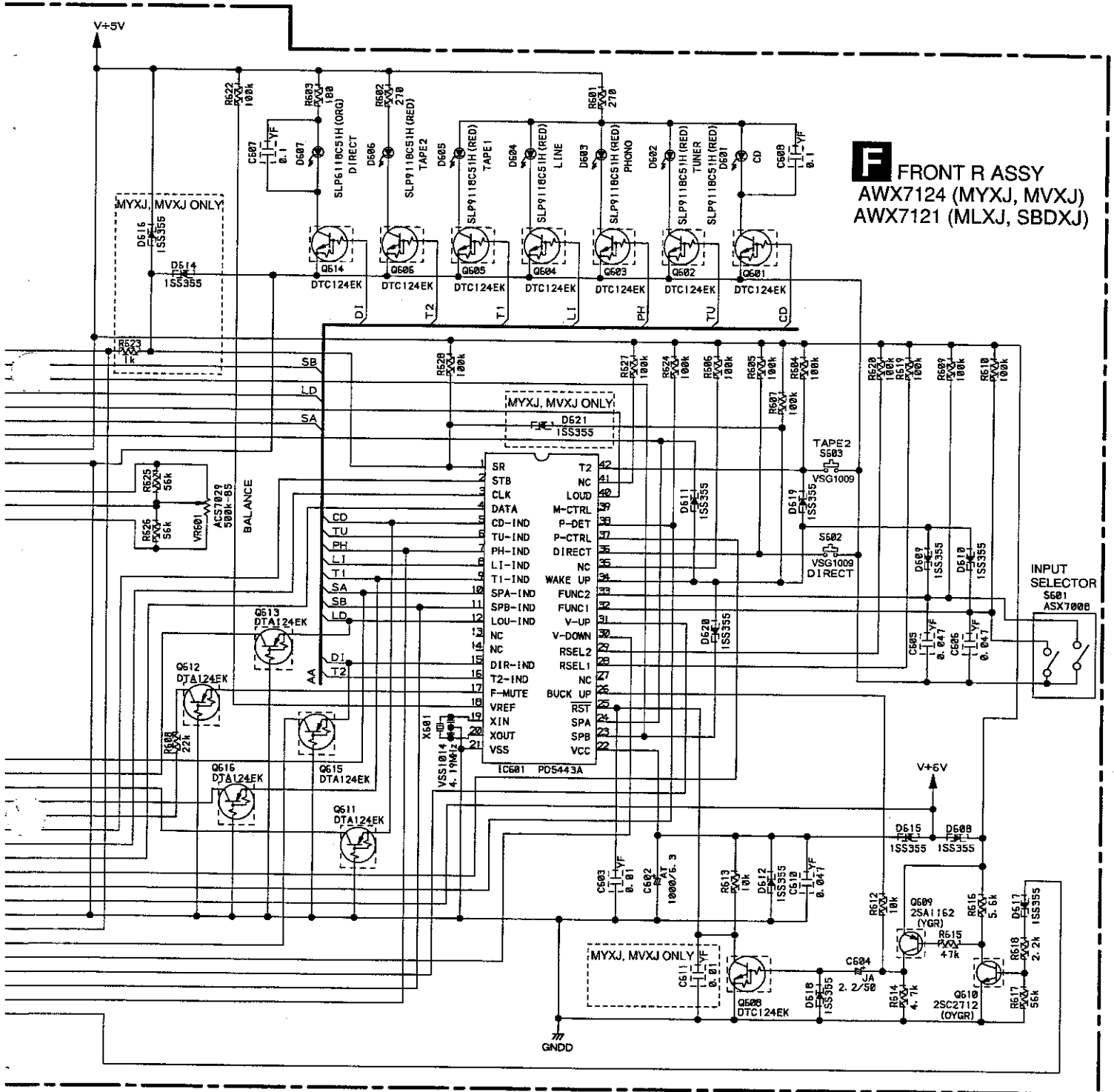

F FRONT R ASSY
 AWX7124 (MYXJ, MVXJ)
 AWX7121 (MLXJ, SBDXJ)

FRONT R ASSY
 S601 : INPUT SELECTOR
 CD
 TUNER
 PHONE
 LINE
 TAPE1/CD-R/MD
 S602 : DIRECT
 S603 : TAPE2 MONITOR

NOTES

- RESISTORS
 INDICATED IN Ohm 1/10W± 5% TOLERANCE UNLESS OTHERWISE NOTED
 k : kOhm
- CAPACITORS
 INDICATED IN CAPACITY (uF) / VOLTAGE (V) UNLESS OTHERWISE NOTED p : pF
 INDICATED WITHOUT VOLTAGE IS 50V EXCEPT ELECTROLYTIC CAPACITOR.
 AL : CEAL, AT : CEAT, JA : CEJA, TY : CFTYA, CH : CCSQCH, YF : CKSQYF
- THE Δ MARK FOUND ON SOME COMPONENT PARTS INDICATES THE IMPORTANCE OF THE SAFETY FACTOR OF THE PART. THEREFORE, WHEN REPLACING, BE SURE TO USE PARTS OF IDENTICAL DESIGNATION.



4. PCB CONNECTION DIAGRAM

4.1 VOLUME ASSY

NOTE FOR PCB DIAGRAMS :

1. Part numbers in PCB diagrams match those in the schematic diagrams.
2. A comparison between the main parts of PCB and schematic diagrams is shown below.

Symbol In PCB Diagrams	Symbol In Schematic Diagrams	Part Name
		Transistor
		Transistor with resistor
		Field effect transistor
		Resistor array
		3-terminal regulator

3. The parts mounted on this PCB include all necessary parts for several destinations.
For further information for respective destinations, be sure to check with the schematic diagram.
4. View point of PCB diagrams.

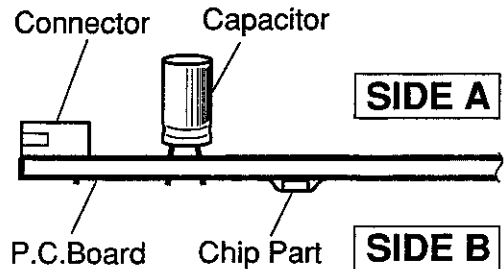

A VOLUME ASSY

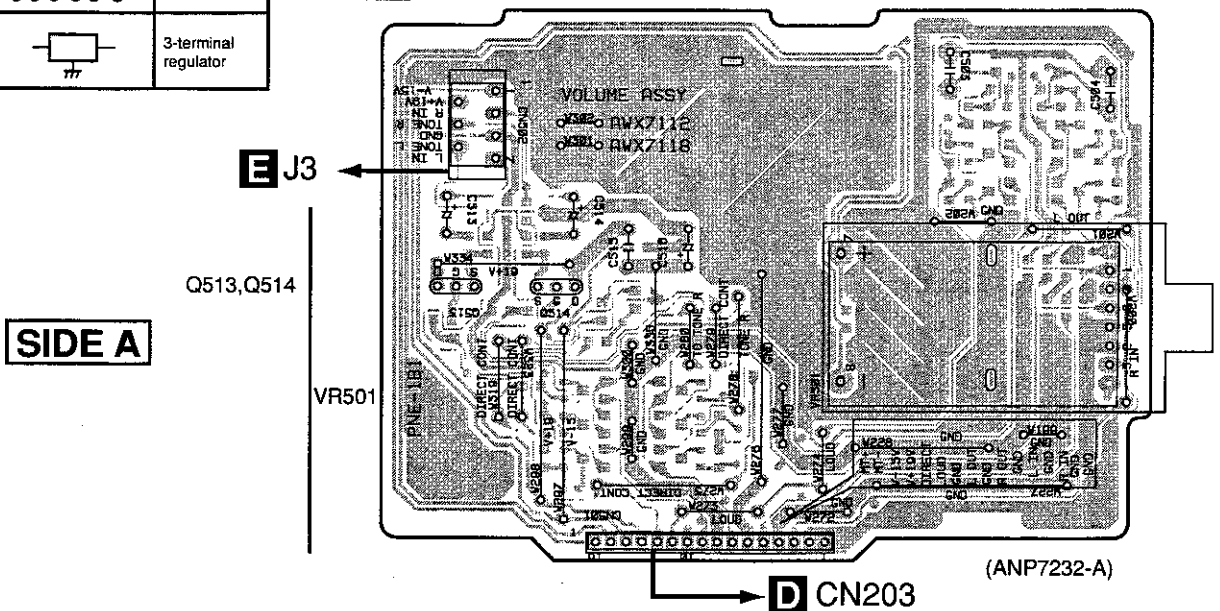

A VOLUME ASSY

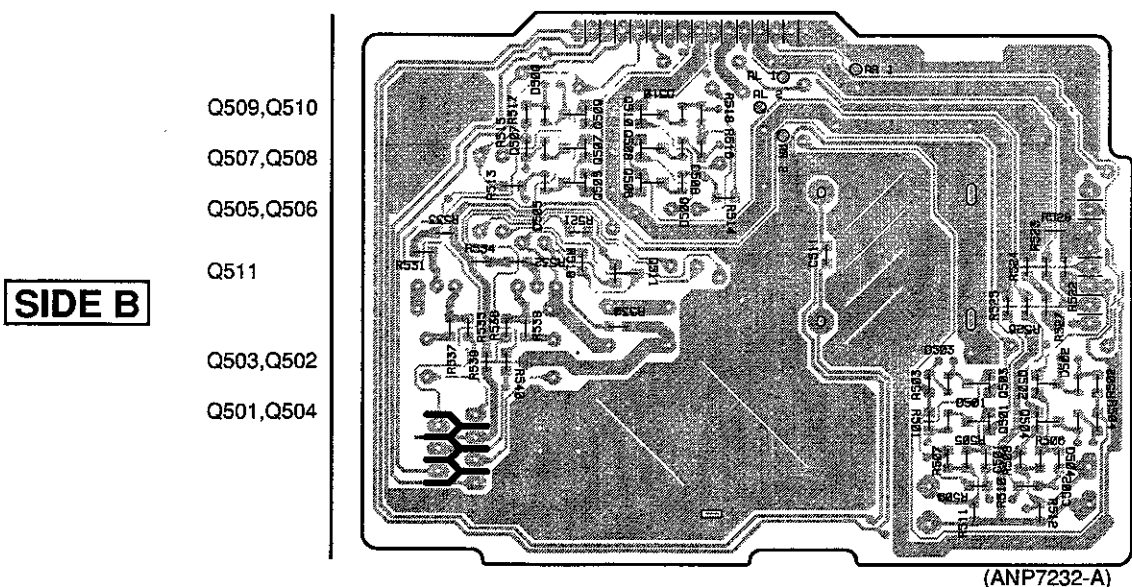

4.2 HEADPHONE and AC PRIMARY ASSYS

B HEADPHONE ASSY

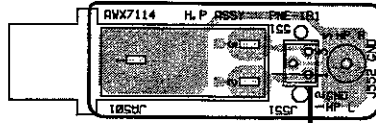

SIDE A

(ANP7232-A)

B HEADPHONE ASSY

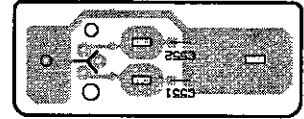

SIDE B

(ANP7232-A)

C AC PRIMARY ASSY

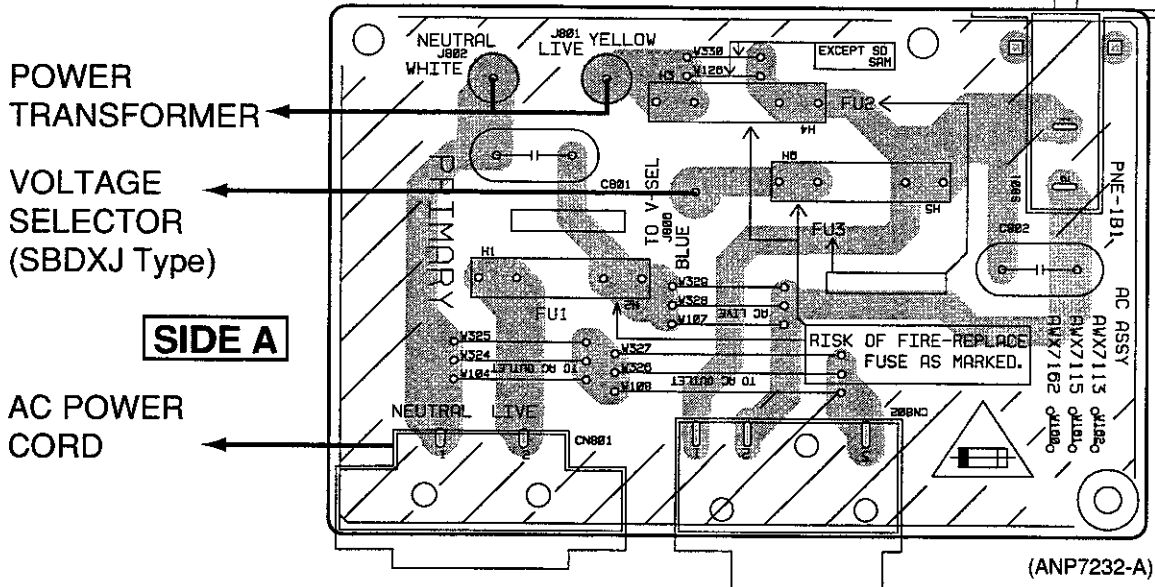

C AC PRIMARY ASSY

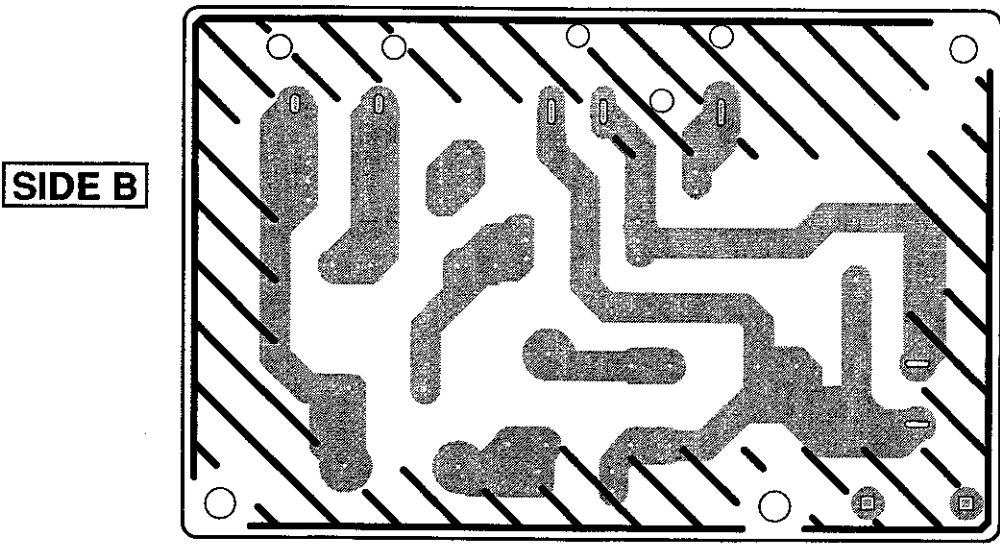

4.3 AF ASSY

D AF ASSY

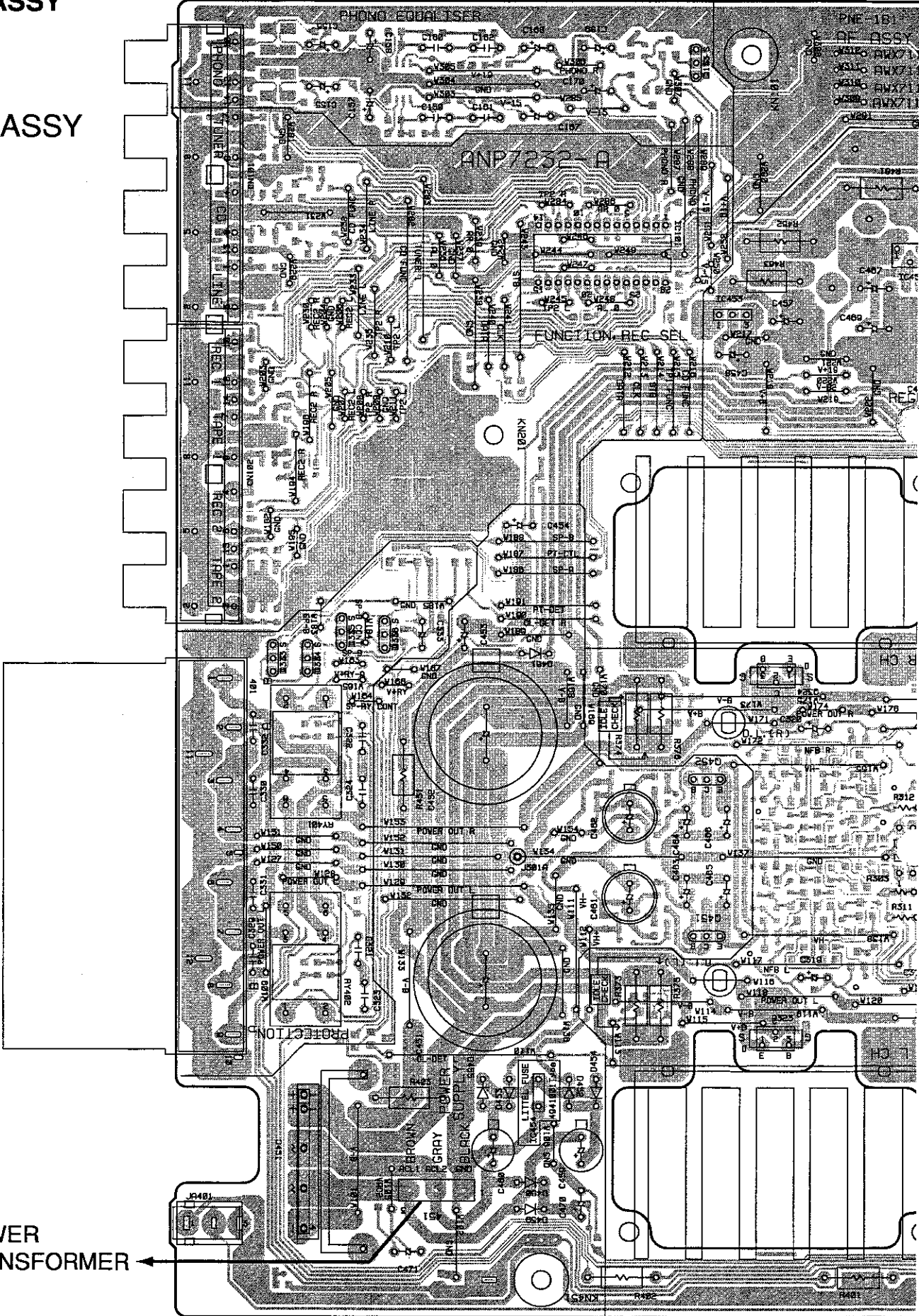

SIDE A

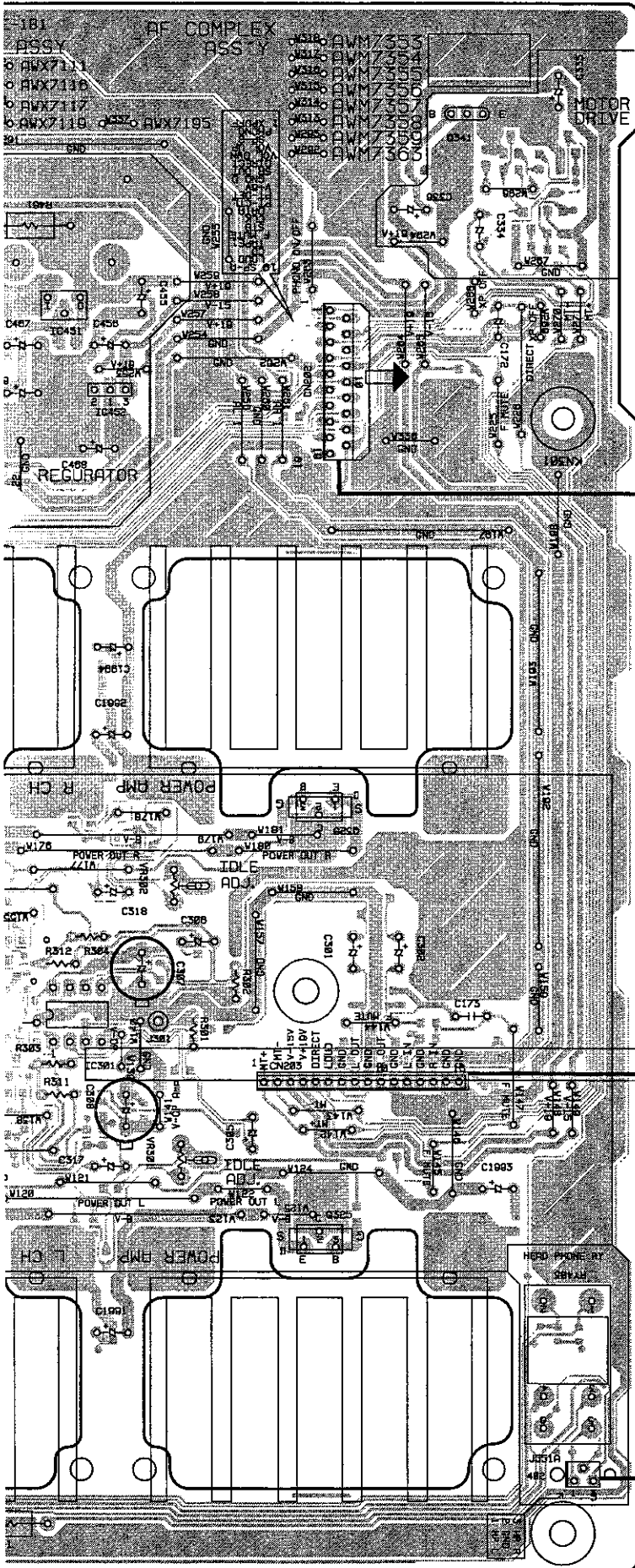

- Q153
- Q341
- IC101
- IC451-IC453

F CN601

- Q333-Q336
- Q324,Q326

VR302

Q452

A CN501

IC301

Q451

VR301

Q323,Q325

IC454

B J551

(ANP7232-A)

D AF ASSY

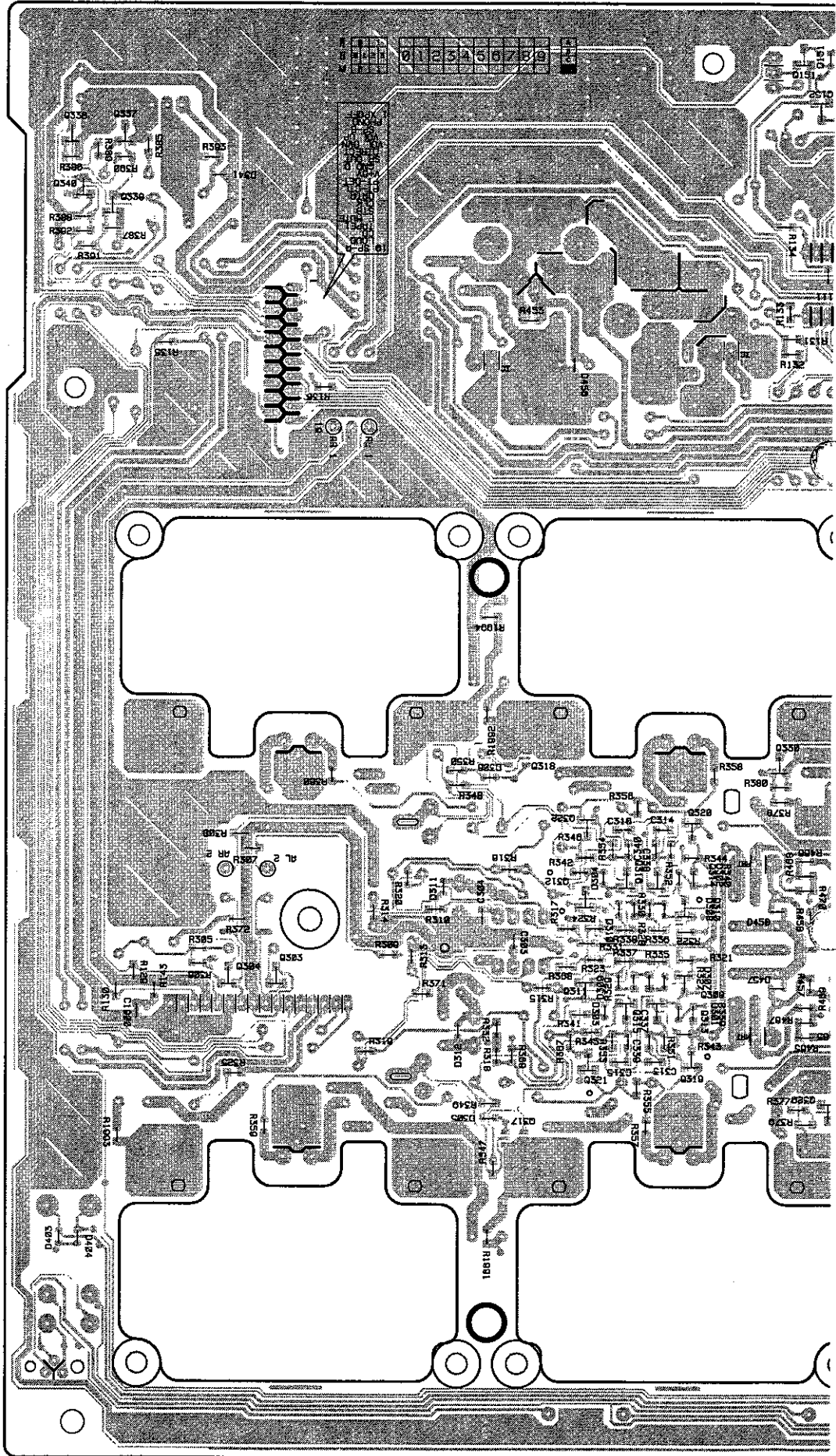

SIDE B

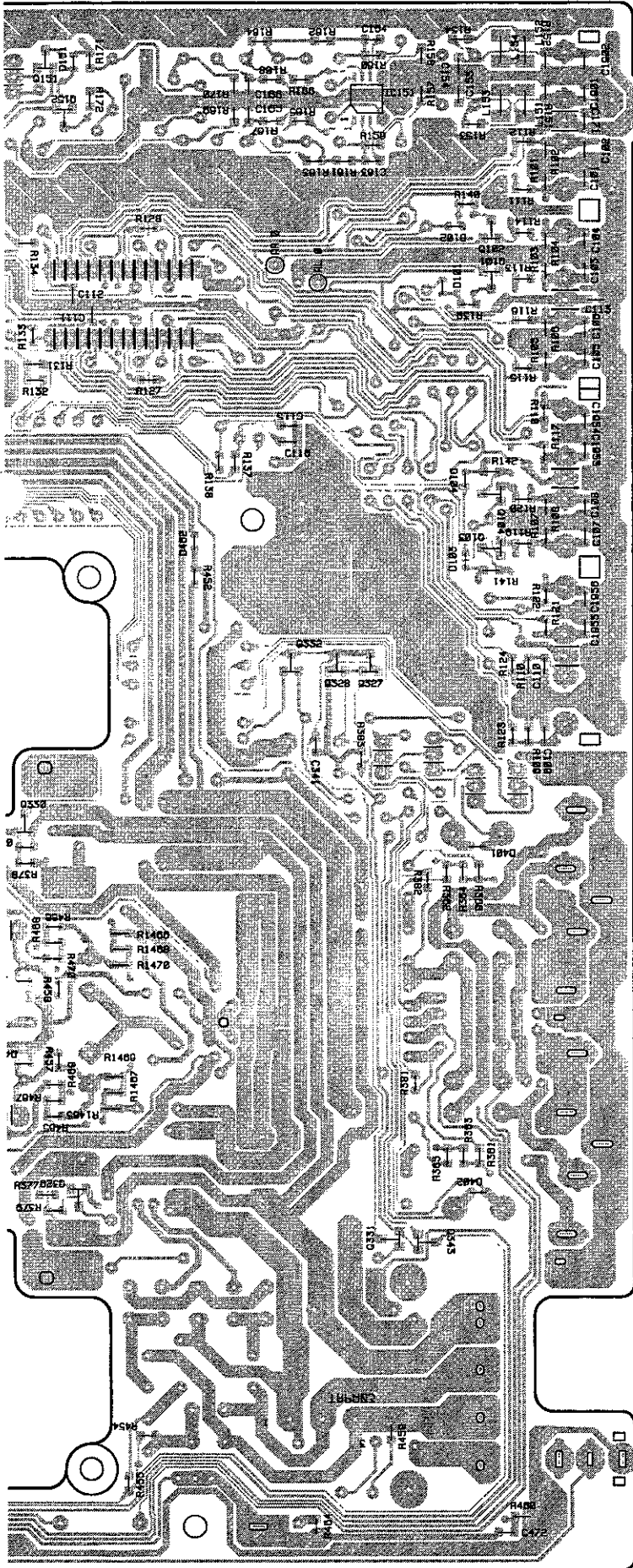

Q151
 IC151
 Q152
 Q338, Q337

Q340, Q339

Q102

Q101

Q104

Q103

Q332
 Q328, Q327

Q318, Q330

Q322, Q320

Q316, Q314

Q312, Q310

Q304, Q303
 Q311, Q309
 Q315, Q313

Q321, Q319

Q317, Q329

Q331, Q343

(ANP7232-A)

4.4 FRONT L ASSY

A

E FRONT L ASSY

G J603A

A CN502 **F** J602

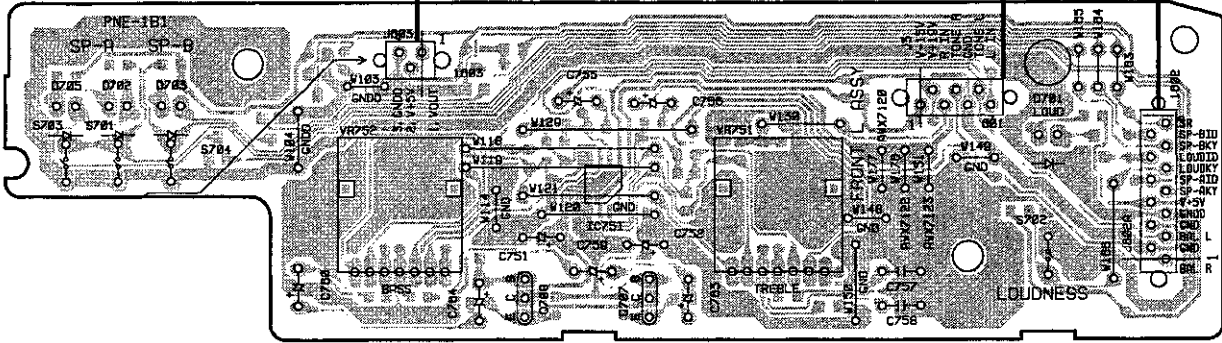

SIDE A

(ANP7231-A)

B

E FRONT L ASSY

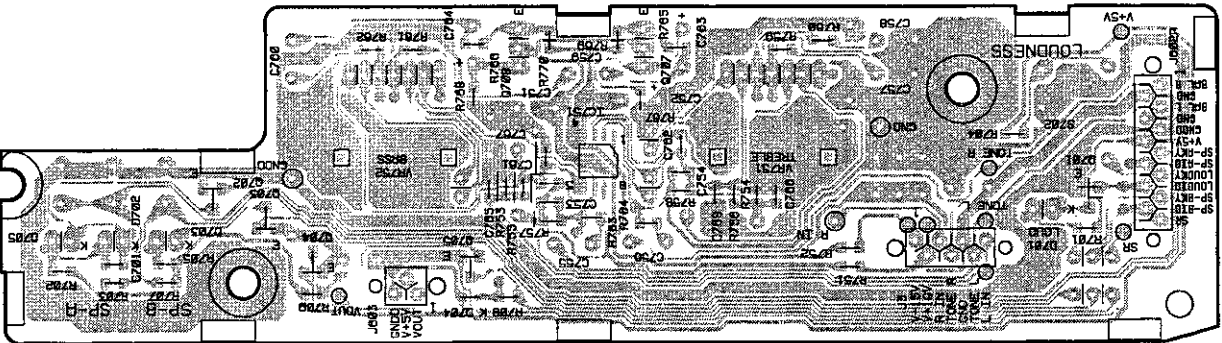

SIDE B

(ANP7231-A)

C



4.5 FRONT R and OPT ASSYS

F FRONT R ASSY

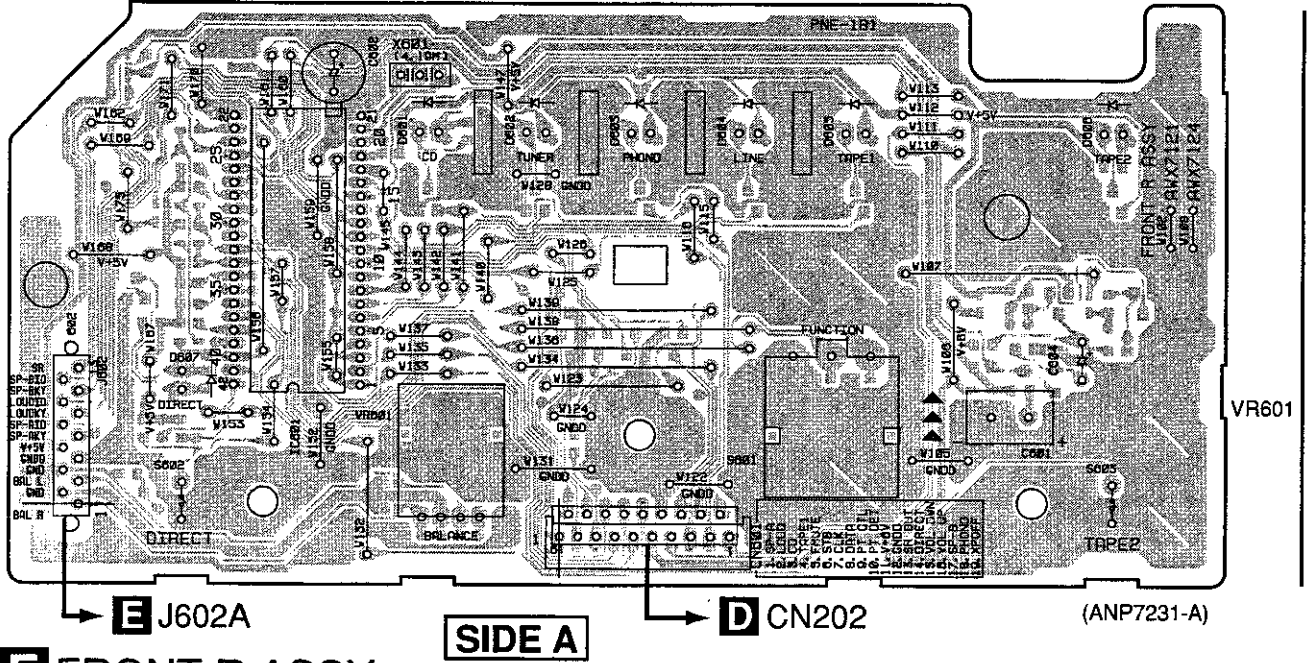

F FRONT R ASSY

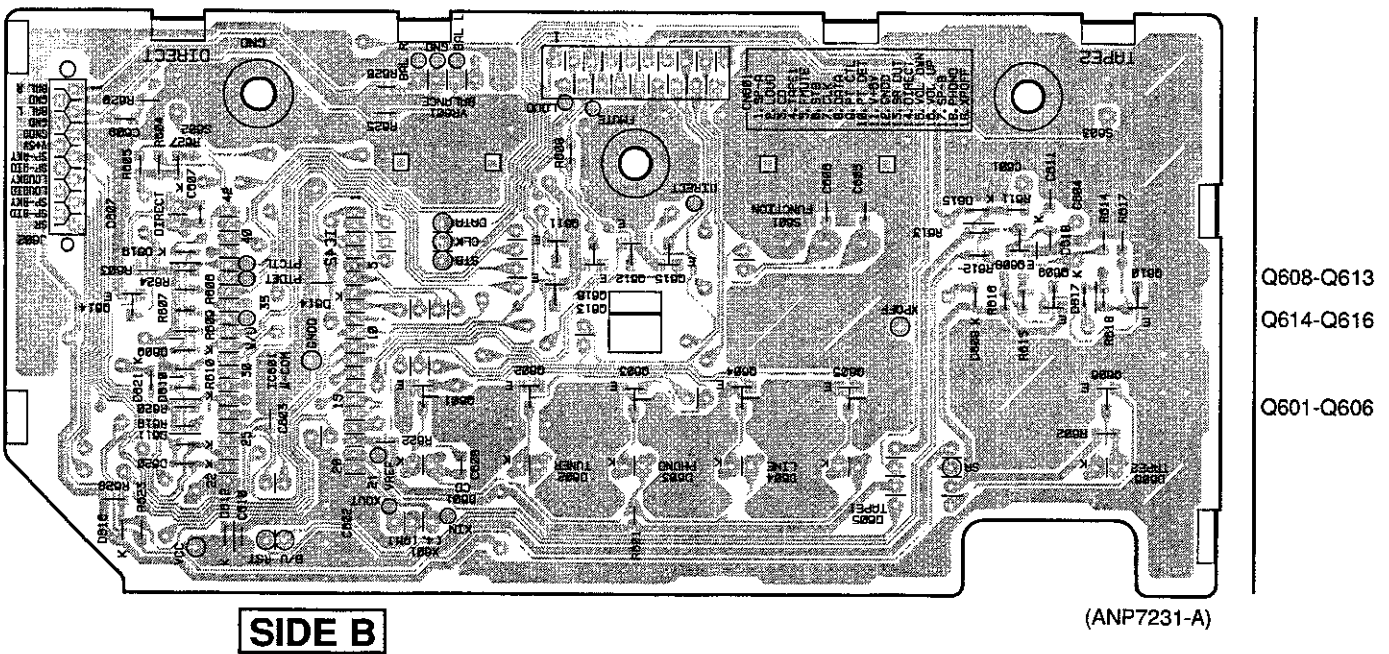

G OPT ASSY

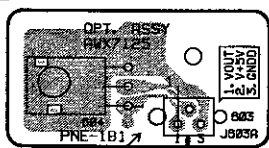

SIDE A

G OPT ASSY

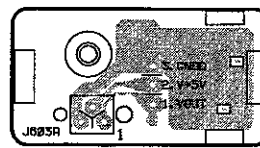

SIDE B



5. PCB PARTS LIST

- NOTES:**
- Parts marked by "NSP" are generally unavailable because they are not in our Master Spare Parts List.
 - The Δ mark found on some component parts indicates the importance of the safety factor of the part. Therefore, when replacing, be sure to use parts of identical designation.
 - When ordering resistors, first convert resistance values into code form as shown in the following examples.
- Ex.1 When there are 2 effective digits (any digit apart from 0), such as 560 ohm and 47k ohm (tolerance is shown by J=5%, and K=10%).
- | | | | | | | | | | | |
|--------------|---|----------------------|-------|-----|-------|---------|---|---|---|---|
| 560 Ω | → | 56 × 10 ¹ | → | 561 | | RD1/4PU | 5 | 6 | 1 | J |
| 47k Ω | → | 47 × 10 ³ | → | 473 | | RD1/4PU | 4 | 7 | 3 | J |
| 0.5 Ω | → | R50 | | | | RN2H | R | 5 | 0 | K |
| 1 Ω | → | 1R0 | | | | RS1P | 1 | R | 0 | K |
- Ex.2 When there are 3 effective digits (such as in high precision metal film resistors).
- | | | | | | | | | | | | |
|----------------|---|-----------------------|---|------|-------|---------|---|---|---|---|---|
| 5.62k Ω | → | 562 × 10 ¹ | → | 5621 | | RN1/4PC | 5 | 6 | 2 | 1 | F |
|----------------|---|-----------------------|---|------|-------|---------|---|---|---|---|---|

LIST OF WHOLE PCB ASSEMBLIES

Mark	Symbol and Description	Part No.				Remarks
		A-209R /MYXJ	A-209R /MVXJ	A-209 /MLXJ	A-209 /SBDXJ	
NSP	AF COMPLEX ASSY	AWM7357	AWM7357	AWM7355	AWM7511	
	└ VOLUME ASSY	AWX7118	AWX7118	AWX7112	AWX7112	
NSP	└ HEADPHONE ASSY	AWX7114	AWX7114	AWX7114	AWX7114	
	└ AC PRIMARY ASSY	AWX7113	AWX7113	AWX7113	AWX7670	
	└ AF ASSY	AWX7117	AWX7117	AWX7116	AWX7116	
NSP	CONTROL ASSY	AWG7013	AWG7013	AWG7012	AWG7012	
	└ FRONT L ASSY	AWX7123	AWX7123	AWX7122	AWX7122	
	└ FRONT R ASSY	AWX7124	AWX7124	AWX7121	AWX7121	
	└ OPT ASSY	AWX7125	AWX7125	Not used	Not used	

Mark No. Description Part No.

A VOLUME ASSY

(1) CONTRAST TABLE

AWX7118 and AWX7112 are constructed the same except for the following :

Mark	Symbol and Description	Part No.		Remarks
		AWX7118	AWX7112	
	C511	CKSQYF473Z50	Not used	
	VR501	ACX7038	ACS7035	

(2) PARTS LIST FOR AWX7118

SEMICONDUCTORS

Q513,Q514	2SK246
Q501-Q510	2SK303
Q511	DTC124EK
D505,D506,D509,D510	1SS352
D501-D504,D507,D508	1SS355

CAPACITORS

C501,C502	CCSQCH271J50
C513,C514	CEAT100M50
C516	CEAT330M25
C503,C504	CFTYA473J50
Δ C515	CKCYF103Z50
C511	CKSQYF473Z50

RESISTORS

Δ R530	RS1/10S100J
VR501	ACX7038
Other Resistors	RS1/10S□□□J

Mark No. Description Part No.

OTHERS

CN501	16P SOCKET	KP200TA16L
CN502	CONNECTOR 7P	KPE7
	PCB BINDER	VEF1040

B HEADPHONE ASSY

CAPACITORS

C551,C552	CKSQYB392K50
-----------	--------------

OTHERS

	3P CABLE HOLDER	51063-0305
J552	CORD WITH PLUG	DE005WE0
JA501	HEADPHONE JACK	RKN1002
J551	JUMPER WIRE	D15A03-150-2651

C AC PRIMARY ASSY

(1) CONTRAST TABLE

AWX7113 and AWX7670 are constructed the same except for the following :

Mark	Symbol and Description	Part No.		Remarks
		AWX7113	AWX7670	
	H3-H6 FUSE CLIP	Not used	AKR7001	
NSP	J806	Not used	DB616EB0	

(2) PARTS LIST FOR AWX7113

SWITCH

Δ S801	ASG1035
---------------	---------

Mark	No.	Description	Part No.
CAPACITORS			
△		C801,C802 (0.01μF/AC250V)	ACG7020

OTHERS

△	CN801	AC INLET	AKP7005
	H1,H2	FUSE CLIP	AKR7001

D AF ASSY

(1) CONTRAST TABLE

AWX7117 and AWX7116 are constructed the same except for the following :

Mark	Symbol and Description	Part No.		Remarks
		AWX7117	AWX7116	
	Q337, Q338	2SA1162	Not used	
	Q339, Q340	2SC2712	Not used	
	Q341	2SC5174P	Not used	
	D341	UDZS5.1B	Not used	
	C334	CEANP100M16	Not used	
△	C335, C336	CEAT100M50	Not used	
	C472	CKSQYF473Z50	Not used	
	R385-R388	RS1/10S473J	Not used	
	R389, R390	RS1/10S471J	Not used	
	R391, R392	RS1/10S102J	Not used	
△	R393	RS1/10S153J	Not used	
	R460	RS1/10S2R2J	Not used	
	JA401 REMOTE CONTROL JACK	RKN1004	Not used	

(2) PARTS LIST FOR AWX7117

SEMICONDUCTORS

△	IC454 (1A)	AEK7009
△	IC453	BA178M06T
△	IC451	BA178M15T
△	IC452	NJM79M15FA
	IC101	TC9163AN
	IC301	UPC4570C
	IC151	UPC4570G2
	Q311, Q312, Q329, Q330	2SA1162
	Q337, Q338	2SA1162
	Q313, Q314, Q321, Q322	2SA1255
△	Q452	2SA1837
	Q309, Q310, Q327, Q328	2SC2712
	Q339, Q340	2SC2712
	Q315, Q316, Q319, Q320	2SC3138
	Q303, Q304	2SC3326
△	Q451	2SC4793
	Q341	2SC5174P
	Q101-Q104	2SK303
	Q151	DTA124EK
	Q152	DTC124EK
	Q153	DTC124ES
	Q331, Q332, Q343	DTC143EK
	Q333-Q336	DTC143ES
	Q317, Q318	IMX1
△	Q323, Q324	IRF530(S)
△	Q325, Q326	IRF9530(S)
	D101-D104, D151, D301-D310	1SS355
	D401-D404	1SS355
△	D451	D5SBA20
△	D452-D455, D459, D460	S5566G(TPB2)

Mark	No.	Description	Part No.
	D461		S5566G(TPB2)
	D311, D312		UDZ15B
	D457, D458		UDZ36B
	D456		UDZ4.7B
	D341		UDZS5.1B
	D462		UDZS5.6B

RELAYS

	RY401-RY403	ASR7014
--	-------------	---------

CAPACITORS

	C451 (6800μF/42V)	ACH7080
	C452 (6800μF/42V)	ACH7081
△	C313-C316, C337-C340	CCSQCH121J50
	C153, C154	CCSQCH151J50
	C303, C304	CCSQCH221J50
	C334	CEANP100M16
	C471	CEANP1R0M2A
	C172	CEANP1R0M50
	C333	CEANP470M10
	C155, C156, C167, C168	CEAT100M50
	C317-C320, C335, C336	CEAT100M50
	C453-C458, C465, C466, C469	CEAT100M50
	C461, C462	CEAT101M2A
	C467, C468	CEAT1R0M50
	C470	CEAT3R3M50
	C169, C170	CEAT470M25
	C459, C460, C463, C464	CEAT470M50
	C157, C158	CEAT471M6R3
	C301, C302, C305, C306	CEBA100M50
	C307, C308	CEBA221M25
	C321-C324	CFTYA224J50
	C173	CFTYA564J50
	C165, C166	CKSQYB222K50
	C111-C113, C171, C341	CKSQYF473Z50
△	C472	CKSQYF473Z50
	C159, C160	CQMA243J50
	C161, C162	CQMA823J50
RESISTORS		
	R311, R312	RDR1/4VM152J
	R301, R302	RDR1/4VM240J
	R303, R304	RDR1/4VM561J
△	R143	RS1/10S100J
△	R133, R134, R171, R172	RS1/10S101J
△	R351-R354, R452	RS1/10S101J
△	R317, R318, R331, R332	RS1/10S122J
△	R357-R360	RS1/10S151J
△	R377, R378, R453	RS1/10S153J
△	R465-R470	RS1/10S161J
△	R361-R366	RS1/10S1R5J
△	R339-R346	RS1/10S221J
△	R454	RS1/10S273J
△	R460	RS1/10S2R2J
△	R355, R356	RS1/10S432J
△	R459	RS1/10S470J
△	R464	RS1/10S4R7J
△	R379, R380	RS1/10S682J
△	R451	RS1LMF270J
△	R401, R402	RS1LMF331J

A-209R, A-209

Mark	No.	Description	Part No.
△	R461-R463		RS1LMF390J
△	R403		RS1LMF821J
△	R373-R376		RS1LMFR22J
	VR301,VR302 (2.2kΩ)		VCP1123
	Other Resistors		RS1/10S□□□J

OTHERS

	3P CABLE HOLDER	51063-0305
	SCREW	ABA1007
	SCREW	ABA1052
	CN101,CN102 8P PIN JACK	AKB7023
	8P SPEAKER TERMINAL	AKE1011
	HEAT SINK M	ANH-813
	HEAT SINK B	ANH1021
	CN202 FFC CONNECTOR 19P	HLEM19S-1
	CN203 16P PLUG	KM200TA16
	JA401 REMOTE CONTROL JACK	RKN1004
	PCB BINDER	VEF1040
	KN101,KN201,KN301,KN451	VNF1084
	EARTH METAL FITTING	

E FRONT L ASSY

(1) CONTRAST TABLE

AWX7123 and AWX7122 are constructed the same except for the following :

Mark	Symbol and Description	Part No.		Remarks
		AWX7123	AWX7122	
	Q704	DTC124EK	Not used	
	Q705	2SC2712	Not used	
	D704	1SS355	Not used	
	R708	RS1/10S472J	Not used	
	R709	RS1/10S223J	Not used	
	J603 JUMPER WIRE	D15A03-100-2651	Not used	
	1603 3P CABLE HOLDER	51063-0305	Not used	

(2) PARTS LIST FOR AWX7123

SEMICONDUCTORS

IC751	UPC4570G2
Q707,Q708	2SC1845
Q705	2SC2712
Q701-Q704	DTC124EK
D704	1SS355
D701,D703,D705	SLP9118C51H

SWITCHES

S702-S704	VSG1009
-----------	---------

CAPACITORS

C753,C754,C761,C762	CCSQCH101J50
C767,C768	CCSQCH221J50
C751,C752,C755,C756	CEAL100M50
C763,C764	CEALR10M50
C759,C760	CEALR47M50
C757,C758	CFTYA153J50
C701	CKSQYF104Z25

RESISTORS

△ R751,R752	RS1/10S101J
VR751,VR752 (30kΩ)	ACS7028
Other Resistors	RS1/10S□□□J

Mark	No.	Description	Part No.
OTHERS			
		3P CABLE HOLDER	51063-0305
		7P CABLE HOLDER	51063-0705
		13P CABLE HOLDER	51063-1305
J603		JUMPER WIRE	D15A03-100-2651
J3		JUMPER WIRE	D15A07-200-2651

F FRONT R ASSY

(1) CONTRAST TABLE

AWX7124 and AWX7121 are constructed the same except for the following :

Mark	Symbol and Description	Part No.		Remarks
		AWX7124	AWX7121	
	D614, D616, D621	1SS355	Not used	
	C611	CKSQYF103Z50	Not used	
	R623	RS1/10S102J	Not used	

(2) PARTS LIST FOR AWX7124

SEMICONDUCTORS

IC601	PD5443A
Q609	2SA1162
Q610	2SC2712
Q611-Q613,Q615,Q616	DTA124EK
Q601-Q606,Q608,Q614	DTC124EK
D608-D612,D614-D621	1SS355
D607	SLP6118C51H
D601-D606	SLP9118C51H

SWITCHES

S602,S603	VSG1009
S601	ASX7008

CAPACITORS

C602	CEAT102M6R3
C604	CEJA2R2M50
C603,C611	CKSQYF103Z50
C607,C608	CKSQYF104Z25
C605,C606,C610	CKSQYF473Z50

RESISTORS

VR601 (500kΩ)	ACS7029
Other Resistors	RS1/10S□□□J

OTHERS

X601 CERAMIC RESONATOR (4.19MHz)	VSS1014
13P CABLE HOLDER	51063-1305
CN601 19P FFC CONNECTOR	9607S-19F
J602 JUMPER WIRE	D15A13-125-2651

G OPT ASSY

OTHERS

3P CABLE HOLDER	51063-0305
REMOTE RECEIVER UNIT	GP1U27X

6. ADJUSTMENT

6.1 IDLE CURRENT ADJUSTMENT

- CAUTION : Heatsinks' (Q323-Q326) DC level is equal to +B or -B.
Don't touch them or you will be electric shocked.

1. Connect the measuring instrument as shown in Fig.6-1. (R373 or R374)
2. Turn the POWER switch to ON.
3. Adjust VR301 (VR302) so that the voltage between both sides of R373 (R374) becomes $10\text{mV} \pm 1\text{mV}$.
4. Ages for 5 minutes.
5. Adjust VR301 (VR302) so that the voltage between both sides of R373 (R374) becomes $11\text{mV} \pm 1\text{mV}$.

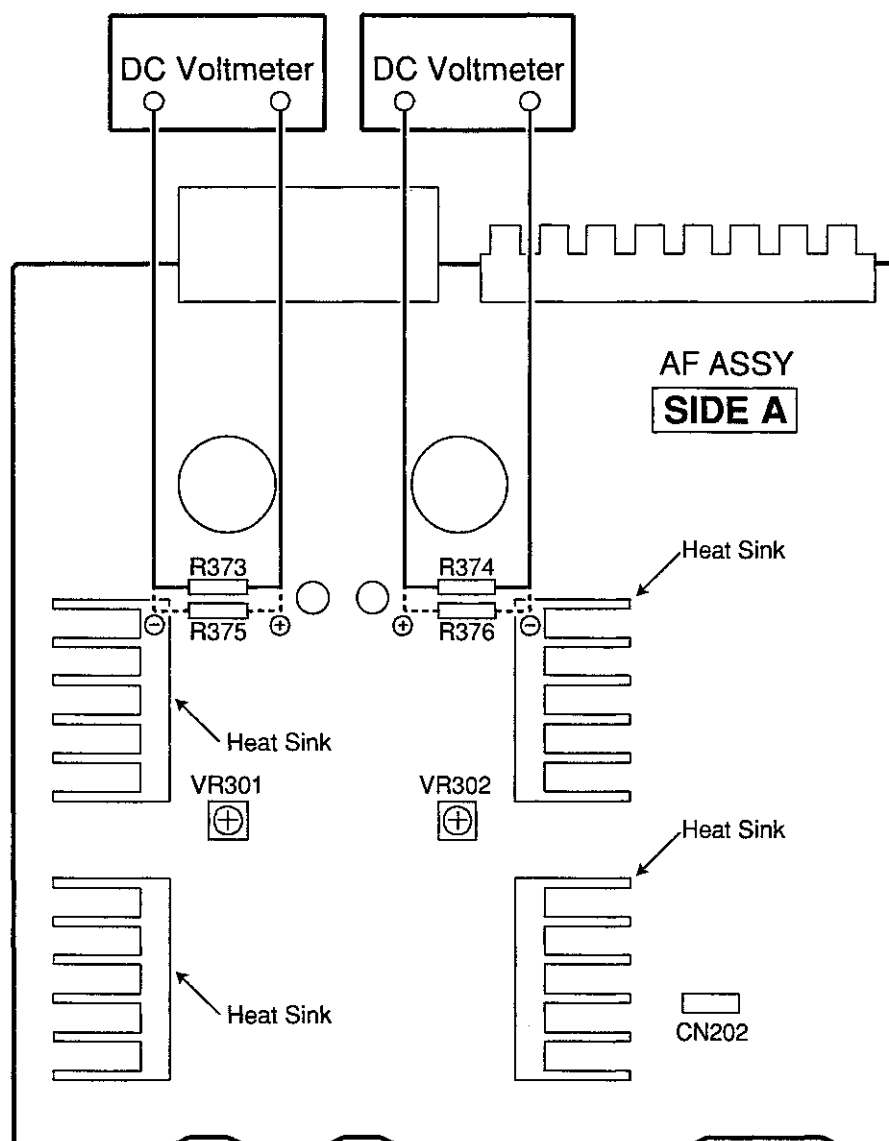
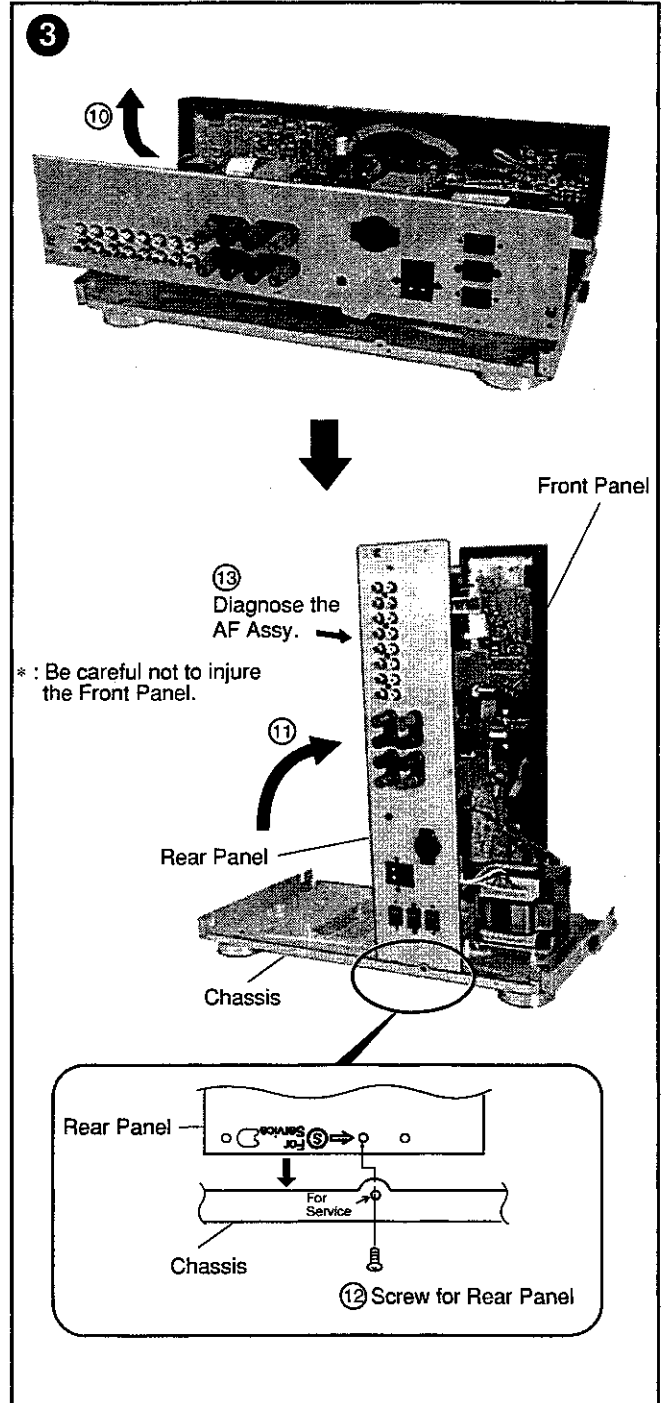
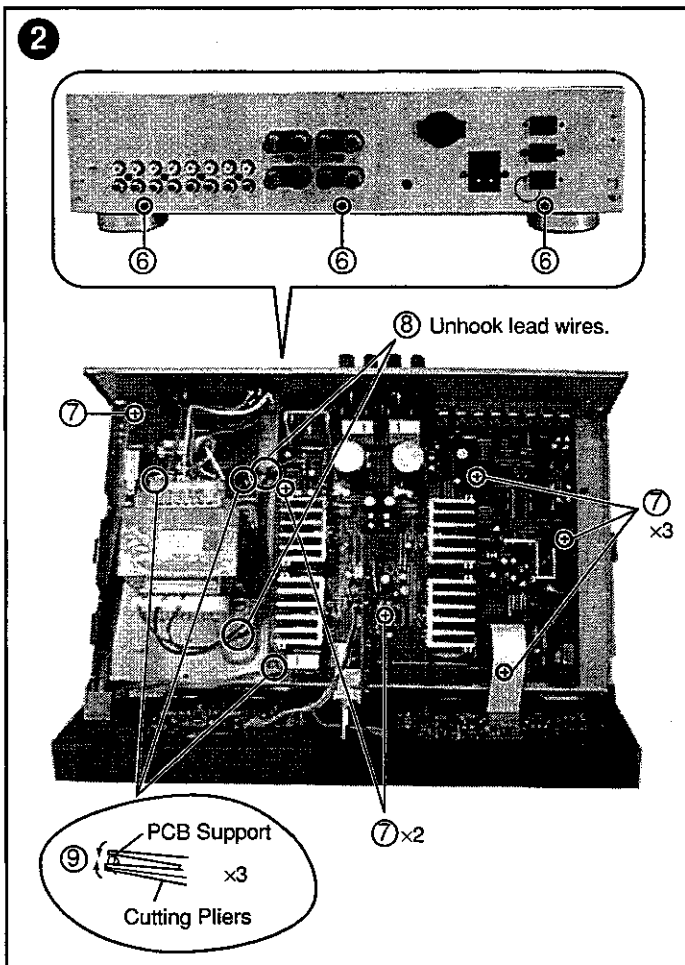
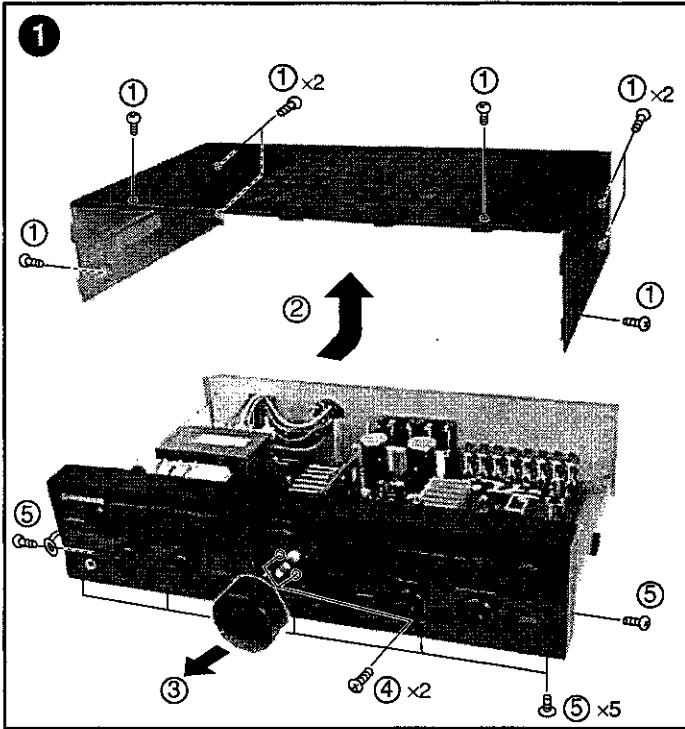

Fig.6-1 Adjustment Method

7. GENERAL INFORMATION

7.1 DISASSEMBLY



7.2 IC

■ PD5443A (FRONT R ASSY : IC601)

● REMOTE CONTROL AMP MICROCOMPUTER

● Pin Assignment (Top view)

- The information shown in the list is basic information and may not correspond exactly to that shown in the schematic diagrams.

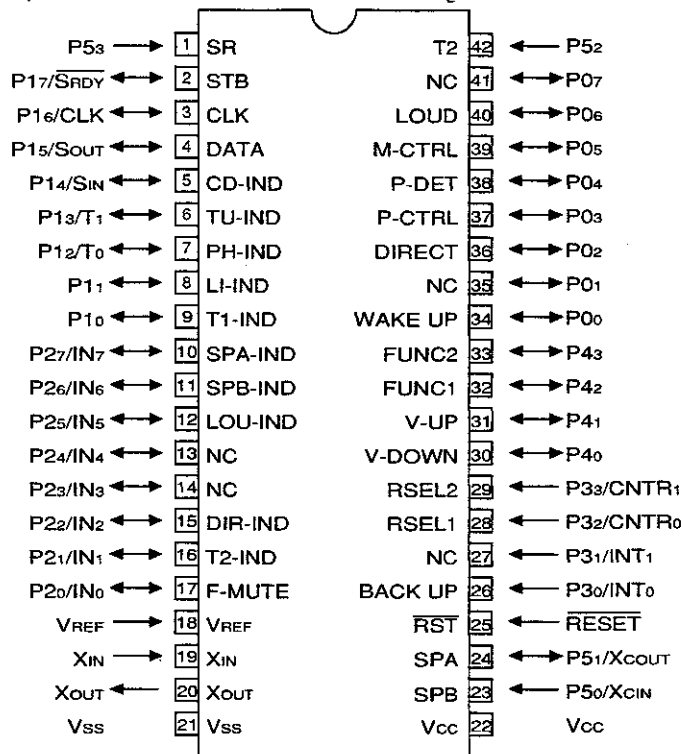

● Pin Function

No.	Pin name	I/O	Function
1	P5 ₃	I	Remote control signal input pin.
2	P1 ₇ /SRDY	O	STB for TC9163N.
3	P1 ₆ /CLK	O	CLOCK for TC9163N.
4	P1 ₅ /SOUT	O	DATA for TC9163N.
5	P1 ₄ /SIN	O	CD INDICATOR.
6	P1 ₃ /T ₁	O	TUNER INDICATOR.
7	P1 ₂ /T ₀	O	PHONO INDICATOR.
8	P1 ₁	O	LINE INDICATOR.
9	P1 ₀	O	TAPE1 INDICATOR.
10	P2 ₇ /IN ₇	O	SPEAKER-A INDICATOR.
11	P2 ₆ /IN ₆	O	SPEAKER-B INDICATOR.
12	P2 ₅ /IN ₅	O	LOUDNESS INDICATOR.
13	P2 ₄ /IN ₄	O	Not used.
14	P2 ₃ /IN ₃	O	Not used.
15	P2 ₂ /IN ₂	O	DIRECT INDICATOR.
16	P2 ₁ /IN ₁	O	TAPE2 INDICATOR.
17	P2 ₀ /IN ₀	O	FUNCTION switch MUTE.
18	VREF	I	Pulls up to 5V.
19	XIN	I	4.19MHz.
20	XOUT	O	Ceramic vibrating and connecting terminal.
21	VSS	-	Digital GND.
22	VCC	-	Power supply +5V.
23	P5 ₀ /XCIN	I	SPEAKER-B KEY input.

No.	Pin name	I/O	Function
24	P5 ₁ /XCOUT	I	SPEAKER-A KEY input.
25	RESET	I	Reset pin.
26	P3 ₀ /INT ₀	I	BACK UP detection pin. interrupt specification.
27	P3 ₁ /INT ₁	I	Not used.
28	P3 ₂ /CNTR ₀	I	REC selector input 1.
29	P3 ₃ /CNTR ₁	I	REC selector input 2. interrupt specification.
30	P4 ₀	O	Volume DOWN data output.
31	P4 ₁	O	Volume UP data output.
32	P4 ₂	I	FUNCTION selector input 1.
33	P4 ₃	I	FUNCTION selector input 2.
34	P0 ₀	I	WAKE UP input. Key on wake up specification.
35	P0 ₁	O	Not used.
36	P0 ₂	I	DIRECT KEY input. Key on wake up specification.
37	P0 ₃	O	Protection control pin.
38	P0 ₄	I	Output error detection pin
39	P0 ₅	O	MUTING control pin.
40	P0 ₆	I	LOUDNESS KEY input. Key on wake up specification.
41	P0 ₇	O	Not used.
42	P5 ₂	I	TAPE2 KEY input.

8. PANEL FACILITIES AND SPECIFICATIONS

8.1 PANEL FACILITIES

[FRONT PANEL]

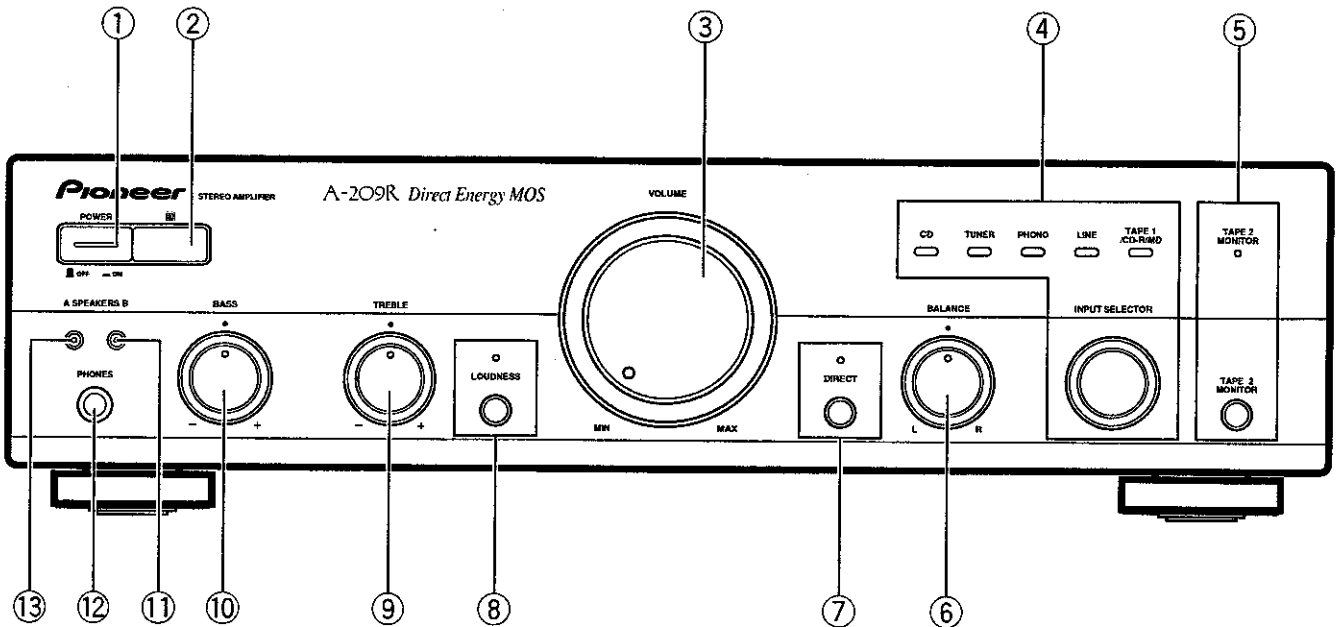

The illustration shows the A-209R.

① POWER (■ OFF/■ ON) switch

Press to turn power to the unit ON and OFF. This unit cannot be turned ON and OFF using the remote control unit.

② REMOTE CONTROL SENSOR window
(on the A-209R only)

③ VOLUME control
Use to adjust the volume level.

④ INPUT SELECTOR knob/indicators
Turn the knob clockwise or counterclockwise so that the indicator lights for your desired input source. Turning the knob clockwise causes the lit indicator to right. Turning counterclockwise causes it to left.

- CD** : For compact disc playback with a CD player.
- TUNER** : For AM or FM broadcast reception with a tuner.
- PHONO** : For record playback with a turntable.
- LINE** : Set to this position when listening to the program from a component connected to the LINE terminals.

TAPE 1/CD-R/MD: For playback with a cassette deck, CD recorder or MD recorder connected to TAPE1/CD-R/MD terminals.

⑤ TAPE 2 MONITOR button/indicator

Use when there is an adaptor component (graphic equalizer, etc.) or cassette deck connected to the TAPE2 MONITOR terminals.

- On** : Indicator lights when using the adaptor component or listening to the cassette deck.
- Off** : Indicator goes off when not in use.

NOTES:

- When no connections are made to the TAPE2 MONITOR terminals, or when they are not in use, be sure to set this switch to the off position. (No sound will be heard if it is set to the on position.)
- When the TAPE2 MONITOR indicator is on and the INPUT SELECTOR knob is not set to TAPE1/CD-R/MD, the signals which are input through TAPE 2 MONITOR are then output at TAPE1/CD-R/MD REC OUT.

⑥ BALANCE control

Should normally be left in the center position. Adjust balance if the sound is louder from one of the speakers. If the right side is louder, turn toward the L (left) position and if the left side is louder, turn toward the R (right) position.

NOTE:

This control does not operate when the DIRECT button is in the on position.

⑦ DIRECT button/indicator

Use this button when you do not wish to pass the output from input terminal equipment through the various frequency adjusting circuits (BASS, TREBLE, BALANCE, LOUDNESS).

On : The indicator lights: The signals passing through the input terminals are reproduced without passing through the various frequency adjusting circuits. This results in flat, pure sound which is a more faithful reproduction of the input source.

Off : The indicator goes off: The signal passes through the various frequency adjusting circuits.

⑧ LOUDNESS button/indicator

Use when listening at low volume levels.

On : The indicator lights: Boosts low and high frequencies to give added punch to playback even at a low volume level.

Off : The indicator goes off: Should normally be left in this position.

NOTE:

This button does not operate when the DIRECT button is in the on position.

⑨ TREBLE tone control

Use to adjust the high-frequency tone. The center position is the flat (normal) position. When turned to the right, high-frequency tones are emphasized; when turned to the left, high-frequency tones are de-emphasized.

NOTE:

This control does not operate when the DIRECT button is in the on position.

⑩ BASS tone control

Use to adjust the low-frequency tone. The center position is the flat (normal) position. When turned to the right, low-frequency tones are emphasized; when turned to the left, low-frequency tones are de-emphasized.

NOTE:

This control does not operate when the DIRECT button is in the on position.

⑪ SPEAKERS B (ON/OFF) button/indicator

Use this button to listen to the speaker system connected to SPEAKERS B terminals.

ON : The indicator lights. Sound is heard from the speaker system.

OFF : The indicator goes off. No sound is heard from the speaker system. Set to this position when listening with headphones.

⑫ PHONES jack

When using headphones, insert the plug into this jack.

NOTE:

The speakers continue to output sound even when headphones are plugged into this jack.

To mute the sound from the speakers, press the SPEAKERS button to OFF.

⑬ SPEAKERS A (ON/OFF) button/indicator

Use this button to listen to the speaker system connected to SPEAKERS A terminals.

ON : The indicator lights. Sound is heard from the speaker system.

OFF : The indicator goes off. No sound is heard from the speaker system. Set to this position when listening with headphones.

A-209R, A-209

[REAR PANEL]

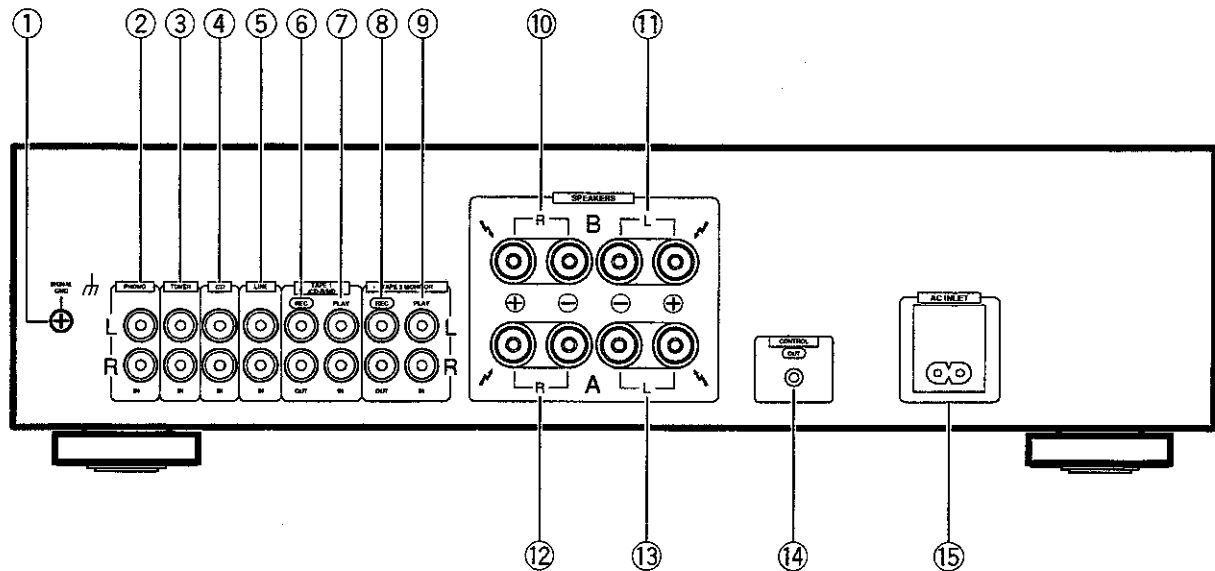

The illustration shows the A-209R.

- | | |
|--------------------------------------|---|
| ① GND (Turntable ground) terminal | ⑩ SPEAKERS B terminals (Right channel) |
| ② PHONO terminals | ⑪ SPEAKERS B terminals (Left channel) |
| ③ TUNER terminals | ⑫ SPEAKERS A terminals (Right channel) |
| ④ CD terminals | ⑬ SPEAKERS A terminals (Left channel) |
| ⑤ LINE terminals | ⑭ CONTROL OUT jack |
| ⑥ TAPE 1/CD-R/MD REC (OUT) terminals | This jack is for output of control signals when operating other components bearing the  mark with the attached remote control unit. (on the A-209R only) |
| ⑦ TAPE 1/CD-R/MD PLAY (IN) terminals | ⑮ AC INLET jack |
| ⑧ TAPE 2 MONITOR REC (OUT) terminals | Connect power cord to here and an AC wall socket, or the AC outlet of an audio timer. |
| ⑨ TAPE 2 MONITOR PLAY (IN) terminals | If you are going to be away from home for a long period of time, disconnect the unit from the wall socket. |

NOTES:

- If you use an other power cord than provided, we cannot assume the liabilities in what may occur as a result of it.
- (The provided power cord has a current capacity of 2.5 A.)

[REMOTE CONTROL] (A-209R)

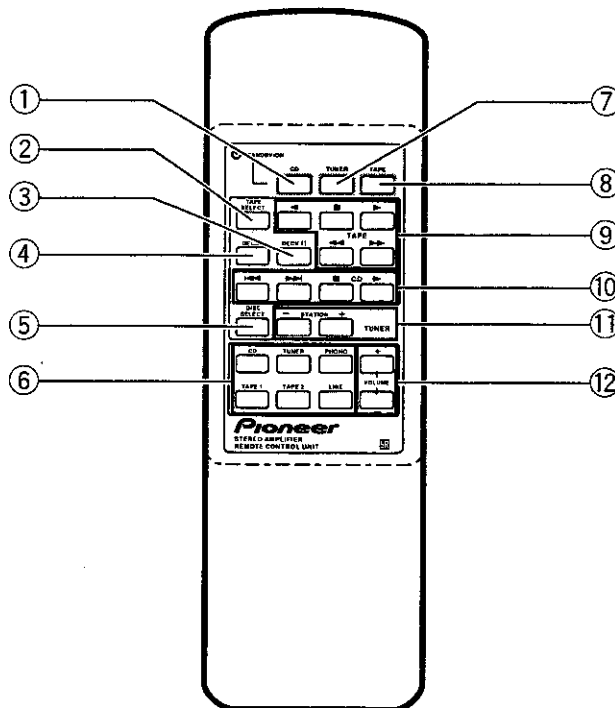

① **CD POWER button**

Switches CD player power ON/OFF.

② **TAPE SELECT button**

Selects the cassette No. (1 to 6) for multi-cassette changer.

③ **DECK II button**

To operate Deck II, press this button before pressing the operating buttons. Also, when using a single deck, press this button before pressing the operating buttons.

④ **DECK I button**

To operate Deck I, press this button before pressing the operating buttons.

⑤ **DISC SELECT button**

Press this to select discs on a multi or twin tray compact disc player.

⑥ **Input selector button**

Use to select the playback source.

CD : For compact disc playback with a CD player.

TUNER : For AM or FM broadcast reception with a tuner.

PHONO : For record playback with a turntable.

TAPE 1 : For playback with a cassette deck, CD recorder or MD recorder connected to TAPE1/CD-R/MD terminals.

TAPE 2 : For playback with a cassette deck or adaptor connected to TAPE 2 MONITOR terminals.

LINE : For playback with a component connected to the LINE terminal.

⑦ **TUNER POWER button**

Switches TUNER power ON/OFF.

⑧ **TAPE POWER button**

Switches the cassette deck power ON/OFF. (Can not turn ON/OFF some cassette decks.)

⑨ **TAPE operation buttons**

◀, ▶ : Playback in the direction of the arrows.

■ : Stop

◀◀, ▶▶ : Tape fast forward/reverse.

⑩ **CD player operation buttons**

◀◀ : Returns you to the start of the current track. (Track search)

▶▶ : Takes you to the start of the next track. (Track search)

■ : Stop

▶ : Play

⑪ **STATION + (up), - (down) buttons**

Calls each station number in sequence.

⑫ **VOLUME + (up), - (down) buttons**

+ Increases the volume.

- Decreases the volume.

NOTE:

When the accessory remote control unit is used to operate other Pioneer components with the  mark, it cannot be used to operate functions which do not correspond to the functions listed on the remote control unit.

A-209R, A-209

8.2 SPECIFICATIONS

Amplifier Section

Continuous power output
(both channels driven at 20 Hz to 20 kHz)**
[A-209R]
T.H.D. 0.1 %, 8 Ω 35 W + 35 W*
T.H.D. 0.15 %, 4 Ω 45 W + 45 W*

DIN Continuous power output
(both channels driven at 1 kHz)
[A-209R]
T.H.D. 1.0 %, 8 Ω 45 W + 45 W
T.H.D. 1.0 %, 4 Ω 60 W + 60 W

Total harmonic distortion**
[A-209R]
20 Hz to 20 kHz, 17.5 W, 8 Ω 0.08 %*

- Power output specification is for when power supply is 230 V.

Input sensitivity/impedance
PHONO (MM) 2.8 mV/50 kΩ
[A-209R]
CD, TUNER, LINE, TAPE1/CD-R/MD, TAPE2 MONITOR
..... 200 mV/50 kΩ

PHONO (MM) overload level
1 kHz, T.H.D. 0.1 % 150 mV

Output level/impedance
TAPE1 REC, TAPE2 MONITOR REC 200 mV/1 kΩ

Frequency response
PHONO (MM) 20 Hz to 20 kHz, ±0.5 dB
[A-209R]
CD, TUNER, LINE, TAPE1/CD-R/MD, TAPE2 MONITOR
..... 5 Hz to 100 kHz, ±0.5 dB*

Tone control
BASS ±8 dB (100 Hz)
TREBLE ±8 dB (10 kHz)

Loudness contour (volume control set at -30 dB position)
..... +6 dB (100 Hz)/+4 dB (10 kHz)

Signal-to-Noise ratio (IHF short circuit, A network)
PHONO (MM, 5 mV input) 85 dB*
[A-209R]
CD, TUNER, LINE, TAPE1/CD-R/MD, TAPE2 MONITOR
..... 106 dB*

Signal-to-Noise ratio (DIN, continuous power/50 mW)
PHONO (MM) 71 dB/67 dB*
[A-209R]
CD, TUNER, LINE, TAPE1/CD-R/MD, TAPE2 MONITOR
..... 91 dB/71 dB*

Power Supply/Miscellaneous

Power requirements AC 220 – 230 V, 50/60 Hz
Power consumption
[A-209R] 130 W
Dimensions (including knobs and other protruding parts)
..... 420 (W) x 114 (H) x 307 (D) mm
Weight (without package)
[A-209R] 4.7 kg

Accessories

Remote control unit 1
Batteries (AA/R6P) 2
Power cord (Rated current 2.5 A) 1
Operating instructions 1
Warranty card 1



NOTE:

Specifications and design are subject to possible modifications without notice, due to improvements.

* Measured with DIRECT button set to on.

** Measured by Audio Spectrum Analyzer.

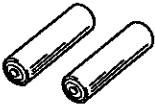
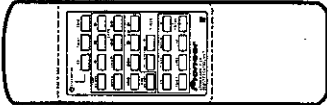
Accessories

	Power cord (MYXJ, MLXJ : ADG1154) (SBDXJ : ADG1154, VKX1007)		
	(MVXJ : ADG1156)	AA size IEC R6P batteries (x2)	Remote control unit (A-209R) CU-A019 (AXD7193)