

# Service Manual

**PIONEER®**  
The Art of Entertainment

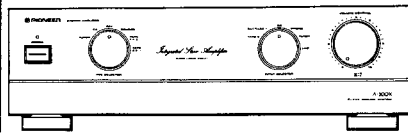

ORDER NO.  
ARP2563

STEREO AMPLIFIER

# A - 300X

A-300X HAS THE FOLLOWING :

Type	Power Requirement	Remarks
HB	AC 220 V, 240 V (switchable)*	

\* Change the connection of the power transformer's primary wiring.

● This manual is applicable to A-300X/HB.

## CONTENTS

1. EXPLODED VIEWS, PACKING AND PARTS LIST	2
2. PCB PARTS LIST	5
3. SCHEMATIC DIAGRAMS	7
4. PCB CONNECTIONS DIAGRAMS	11
5. ADJUSTMENTS	17
6. PANEL FACILITIES	18
7. SPECIFICATIONS	19

**PIONEER ELECTRONIC CORPORATION** 4-1, Meguro 1-Chome, Meguro-ku, Tokyo 153, Japan  
**PIONEER ELECTRONICS SERVICE INC.** P.O. Box 1760, Long Beach, California 90801 U.S.A.  
**PIONEER ELECTRONICS OF CANADA, INC.** 300 Allstate Parkway Markham, Ontario L3R 0P2 Canada  
**PIONEER ELECTRONIC [EUROPE] N.V.** Haven 1087 Keetberglaan 1, 9120 Melsele, Belgium  
**PIONEER ELECTRONICS AUSTRALIA PTY. LTD.** 178-184 Boundary Road, Braeside, Victoria 3195, Australia TEL: [03] 580-9911  
 © PIONEER ELECTRONIC CORPORATION 1992

FG JUNE 1992 Printed in

# 1. EXPLODED VIEWS, PACKING AND PARTS LIST

**NOTES:**

- Parts marked by "NSP" are generally unavailable because they are not in our Master Spare Parts List.
- The  $\Delta$  mark found on some component parts indicates the importance of the safety factor of the part. Therefore, when replacing, be sure to use parts of identical designation.
- Parts marked by "⊙" are not always kept in stock. Their delivery time may be longer than usual or they may be unavailable.

Mark No.	Description	Parts No.	Mark No.	Description	Parts No.
1	ROTARY KNOB L (PLS)	AAB1160	46	S1 SWITCH	ASU1035
2	ROTARY KNOB R (PLS)	AAB1162	47	S2 SWITCH	ASU1037
3	ROTARY KNOB M (PLS)	AAB1231	$\Delta$ 48	T1 POWER TRANSFORMER	ATS1278
4	.....		⊙ 49	AF COMPLEX ASS'Y	AWZ4522
5	KNOB (POWER)	AAD1535	NSP 50	POWER SW ASS'Y	AWZ2856
6	NAME PLATE (METAL)	AAM1029	NSP 51	LED ASS'Y	AWZ4524
7	SCREW	ABA-298	52	.....	
8	SCREW (STEEL)	ABA1009	53	.....	
9	SCREW (STEEL)	ABA1011	$\Delta$ 54	R1 RESISTOR	RD1/4PMF010J
10	SCREW (STEEL)	ABA1016	NSP 55	BINDER	AEF1004
11	SCREW (STEEL)	ABA1048	NSP 56	SHIELD ASS'Y	AWZ2860
12	SCREW (STEEL)	ABA1050	57	.....	
13	SCREW	ABA1082	58	.....	
14	SPRING	ABH-052	59	.....	
15	.....		NSP 60	BARRIER	AEC1443
$\Delta$ 16	AC POWER CORD	ADG1070	NSP 61	SPACER	AEC1256
17	RIVET	AEC-441	62	BINDER	AEP-215
18	SHEET	AEE1014			
19	STYROL PROTECTOR	AHA1335			
20	PACKING CASE	AHD2350			
21	COVER SHEET	AHG1016			
NSP 22	TERMINAL SCREW	AKE-031			
23	PANEL BASE	AMB1651			
24	INDICATING LENS	AMR1160			
25	INSULATOR ASS'Y	AMR2140			
26	C2 CAPACITOR	ACG1005			
NSP 27	CHASSIS	ANA1121			
28	FRONT PANEL	ANB1532			
NSP 29	REAR PANEL	ANC1550			
30	METAL BONNET	AZN1799			
NSP 31	BOTTOM PLATE	ANF1031			
32	AC CORD SPACER	ANG1153			
NSP 33	PCB HOLDER	ANG1442			
NSP 34	HEAT SINK	ANH1260			
35	OPERATING INSTRUCTIONS (ENGLISH)	ARB1391			
36	SCREW	BBT30P060FZK			
37	NUTS	NK90FZB			
38	C1 CAPACITOR	ACG1005			
$\Delta$ 39	FU1 FUSE (T1.6A)	AEK-510			
$\Delta$ 40	Q1 TRANSISTOR	2SC3181N			
$\Delta$ 41	Q2 TRANSISTOR	2SC3181N			
$\Delta$ 42	Q3 TRANSISTOR	2SA1264N			
$\Delta$ 43	Q4 TRANSISTOR	2SA1264N			
$\Delta$ 44	Q5 TRANSISTOR	2SC4137			
$\Delta$ 45	Q6 TRANSISTOR	2SC4137			

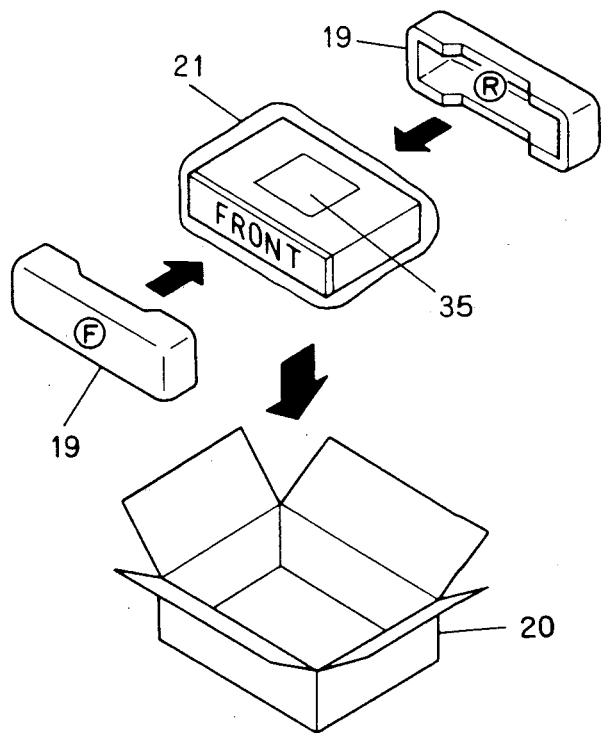

1 2 3 4 5 6

A  
B  
C  
D

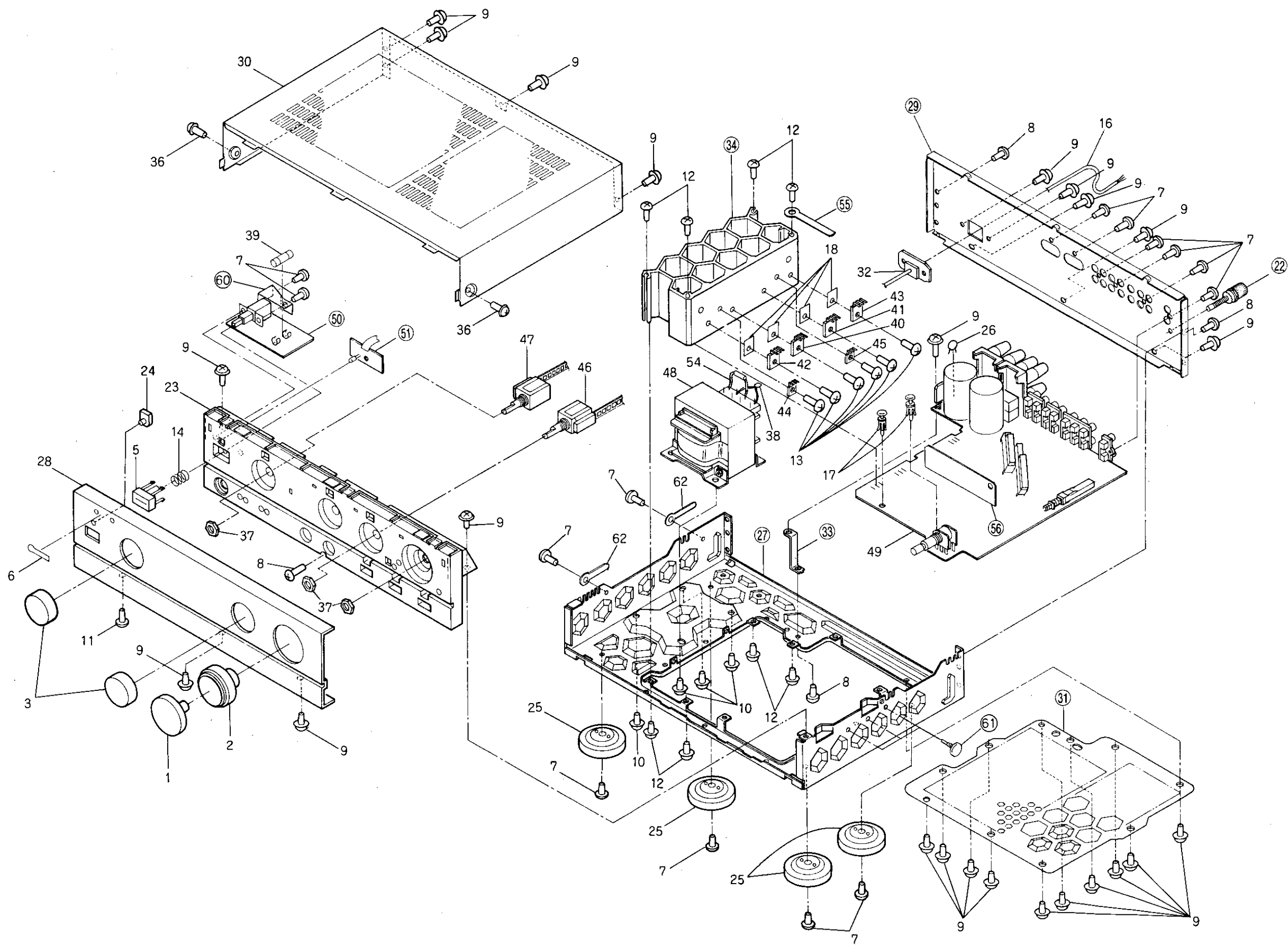

1 2 3 4 5 6

## 2. F

**NOTES.**  
 ● Parts  
 ● The Δ  
 be su  
 ● Parts  
 ● When  
 Ex.1

Ex.2

### Mark ↓

### LIST

● AF  
 ● NSP PO  
 ● NSP LEI  
 ● NSP SHI

### POW

CAPAC  
 Δ C5  
 SWITCH  
 Δ S5

### LED

SEMIC  
 D6

### AF C

SEMIC  
 IC1  
 Q2  
 Q2  
 Q2  
 Q2  
 Q2

Q2  
 Q2  
 Q2  
 Q2  
 Q2

Q2  
 Q2  
 Q2  
 Q2  
 Q2

Q3  
 Q3  
 Q3  
 Q3  
 Q3

## 2. PCB PARTS LIST

**NOTES:**

- Parts marked by "NSP" are generally unavailable because they are not in our Master Spare Parts List.
- The  $\Delta$  mark found on some component parts indicates the importance of the safety factor of the part. Therefore, when replacing, be sure to use parts of identical designation.
- Parts marked by "⊙" are not always kept in stock. Their delivery time may be longer than usual or they may be unavailable.
- When ordering resistors, first convert resistance values into code form as shown in the following examples.

Ex.1 When there are 2 effective digits (any digit apart from 0), such as 560 ohm and 47k ohm (tolerance is shown by J = 5%, and K = 10%).

560Ω → 56 × 10<sup>0</sup> → 561 ..... RD1/8PM561J  
 47kΩ → 47 × 10<sup>3</sup> → 479 ..... RD1/4PS479J  
 0.5Ω → 0R5 ..... RN2H0R5K  
 1Ω → 010 ..... RS1P010K

Ex.2 When there are 3 effective digits (such as in high precision metal film resistors).

5.62kΩ → 562 × 10<sup>1</sup> → 5621 ..... RN1/4PC5621F

Mark No. Description Parts No.

### LIST OF ASSEMBLIES

⊙ AF COMPLEX ASSY AWZ4522  
 NSP POWER SW ASSY AWZ2856  
 NSP LED ASSY AWZ4524  
 NSP SHIELD ASSY AWZ2860

### POWER SW ASS'Y

CAPACITORS  
 $\Delta$  C510,C511 CKA (0.01/AC400V) ACG1002

### SWITCH

$\Delta$  S501 PUSH SWITCH ASG1035

### LED ASS'Y

SEMICONDUCTOR  
 D604 LED (RED) AEL1065

### AF COMPLEX ASS'Y

SEMICONDUCTORS  
 IC101 IC M5220P  
 Q201,Q202 TRANSISTOR 2SA979  
 Q203-Q208 TRANSISTOR 2SA1048  
 Q211,Q212 TRANSISTOR 2SC1845  
 Q215-Q218 TRANSISTOR 2SA1048  
  
 Q219,Q220 TRANSISTOR 2SC2705  
 Q221,Q222 TRANSISTOR 2SC3298  
 Q223,Q224 TRANSISTOR 2SA1306  
 Q225,Q226 TRANSISTOR 2SC2603  
 Q227,Q228 TRANSISTOR 2SC1845  
  
 Q229,Q230 TRANSISTOR 2SA992  
 Q231,Q232 TRANSISTOR 2SA1145  
 Q233,Q234 TRANSISTOR 2SA992  
 Q237 TRANSISTOR 2SC1845  
 Q238 TRANSISTOR 2SA992  
  
 Q301,Q302 TRANSISTOR 2SC1845  
 Q303,Q304 TRANSISTOR 2SC2458  
 Q305 TRANSISTOR 2SA1048  
 Q306 TRANSISTOR 2SC1815  
 Q307 TRANSISTOR 2SC2458

Mark No. Description Parts No.

D201,D202 ZENER DIODE RD2.7ESB1  
 D209-D216 DIODE HSS104-02  
 D217-D220 ZENER DIODE RD8.2ESB1  
 D301-D306 DIODE HSS104-02  
 D307 ZENER DIODE RD15ESB

D503,D504 ZENER DIODE RD16ESB3  
 D505,D506 DIODE 11E2  
 D507 DIODE D5SB20F

COILS & FILTERS  
 L401,L402 COIL ATH1004

### CAPACITORS

C103,C104 CERAMIC CAPACITOR CCCSL221J50  
 C107,C108 ELECTR. CAPACITOR CEXA101M25  
 C109,C110 AUDIO FILM CAPACITOR CFTXA683J50  
 C111,C112 AUDIO FILM CAPACITOR CFTXA183J50  
 C113,C114 ELECTR. CAPACITOR CEXA4R7M50

C143,C144 MYLOR FILM CAPACITOR CQMA472K50  
 C117,C118 ELECTR. CAPACITOR CEAS221M25  
 C121,C122 MYLOR FILM CAPACITOR CQMA122J50  
 C123,C124 ELECTR. CAPACITOR CEXA100M50  
 C201,C202 ELECTR. CAPACITOR CEEA2R2M50

C203,C204 CERAMIC CAPACITOR CCCSL101K500  
 C205,C206 CERAMIC CAPACITOR CCCSL101J50  
 C207,C208 CERAMIC CAPACITOR CCCSL470J50  
 C209,C210 CERAMIC CAPACITOR CCCSL101J50  
 C211,C212 ELECTR. CAPACITOR CEEA221M16

C213-C216 CERAMIC CAPACITOR CCCSL150K500  
 C217,C218 ELECTR. CAPACITOR CEAS101M10  
 C219-C222 ELECTR. CAPACITOR CEAS3R3M100  
 C225,C226 ELECTR. CAPACITOR CEAS331M10  
 C227-C230 CERAMIC CAPACITOR CCCSL330K500

C231,C232 CERAMIC CAPACITOR CKCYB122K50  
 C233-C236 ELECTR. CAPACITOR CEAS100M50  
 C237,C238 ELECTR. CAPACITOR CEAS101M50  
 C251-C254 CERAMIC CAPACITOR CCCSL330K500  
 C255 CERAMIC CAPACITOR CCCSL680J50

Mark No. Description Parts No.

C256 CERAMIC CAPACITOR CCDSL470J50  
 C301,C302 ELECTR. CAPACITOR CEAS2R2M50  
 C303 ELECTR. CAPACITOR CEAS471M6  
 C304 CERAMIC CAPACITOR CKCYF103Z50  
 C305 ELECTR. CAPACITOR CEAS101M25

C306 ELECTR. CAPACITOR CEASR47M50  
 C401-C404 AUDIO FILM CAPACITOR CFTXA104J50  
 C501,C502 ELECTR. CAPACITOR CEAS221M25  
 C505 ELECTR. CAPACITOR ACH1189  
 (6800/50V)

C506 ELECTR. CAPACITOR ACH1190  
 (6800/50V)

C508 ELECTR. CAPACITOR CEHAQ101M50  
 C509 ELECTR. CAPACITOR CEHAQ220M50  
 C725 CERAMIC CAPACITOR CKCYF103Z50  
 C731 CERAMIC CAPACITOR CKCYF103Z50

### RESISTORS

VR201,VR202 SEMI-FIXED (47K) ACP1045  
 VR701 VARIABLE (100K-20AX2) ACT1063  
 R105,R106 CARBON FILM RESISTOR RDR1/6PU100J  
 R121,R122 CARBON FILM RESISTOR RDR1/4PM820J  
 R133,R134 CARBON FILM RESISTOR RDR1/6PU471J

R141,R142 CARBON FILM RESISTOR RDR1/6PU563J  
 R143,R144 CARBON FILM RESISTOR RD1/4PM560J  
 R201-R204 CARBON FILM RESISTOR RDR1/4PM□□□J  
 R205-R214 CARBON FILM RESISTOR RD1/4PM□□□J  
 R215-R218 CARBON FILM RESISTOR RDR1/4PM□□□J

R219-R234 CARBON FILM RESISTOR RD1/4PM□□□J  
 R237,R238 CARBON FILM RESISTOR RDR1/4PM563J  
 $\Delta$  R239-R242 FUSIBLE RESISTOR RFA1/4PS101J  
 $\Delta$  R243,R244 CARBON FILM RESISTOR RD1/4PMF561J  
 $\Delta$  R245-R248 FUSIBLE RESISTOR RFA1/4PS101J

R249-R252 CARBON FILM RESISTOR RD1/4PM□□□J  
 $\Delta$  R257-R260 FUSIBLE RESISTOR RFA1/4PS101J  
 $\Delta$  R261-R264 FUSIBLE RESISTOR RFA1/4PS470J  
 $\Delta$  R265-R268 FUSIBLE RESISTOR RFA1/4PS4R7J  
 $\Delta$  R269,R270 RESISTOR (0.33, 5W) ACN1087

Mark No. Description Parts No.

R275-R278 CARBON FILM RESISTOR RD1/4PM□□□J  
 $\Delta$  R281-R284 FUSIBLE RESISTOR RFA1/4PS331J  
 $\Delta$  R285,R286 FUSIBLE RESISTOR RFA1/4PS101J  
 $\Delta$  R287,R288 CARBON FILM RESISTOR RD1/4PMF4R7J  
 $\Delta$  R289,R290 FUSIBLE RESISTOR RFA1/4PS331J

R299 CARBON FILM RESISTOR RD1/4PM100J  
 R301,R302 CARBON FILM RESISTOR RD1/4PMF222J  
 R308 CARBON FILM RESISTOR RD1/4PMF101J  
 R311-R315 CARBON FILM RESISTOR RD1/4PM□□□J  
 R326 CARBON FILM RESISTOR RD1/4PM181J

R330 CARBON FILM RESISTOR RD1/4PMF010J  
 R401,R402 CARBON FILM RESISTOR RD1/4PMFL100J  
 R407,R408 CARBON FILM RESISTOR RD1/4PMFL100J  
 R501-R506 CARBON FILM RESISTOR RD1/2PM□□□J

R508 CARBON FILM RESISTOR RD1/4PMF010J  
 R509,R510 METAL OXIDE RESISTOR RS1LMF332J  
 R517-R520 CARBON FILM RESISTOR RD1/2PM471J  
 R731,R732 CARBON FILM RESISTOR RD1/4PM103J  
 OTHER RESISTORS RD1/8PM□□□J

### SWITCHES

S701 SWITCH ASU1016  
 S702 SWITCH ASU1002

### OTHERS

RY301 RELAY ASR-111  
 PHONO JACK 4-P AKB1007  
 PHONO JACK 6-P AKB1008  
  
 PHONO JACK 2-P AKB1059  
 SPEAKER TERMINAL 4-P AKE1020

### SHIELD ASS'Y

No parts supplied with the SHIELD Ass'y.

A

B

C

D

### 3. SCHEMATIC DIAGRAMS

A

B

C

D

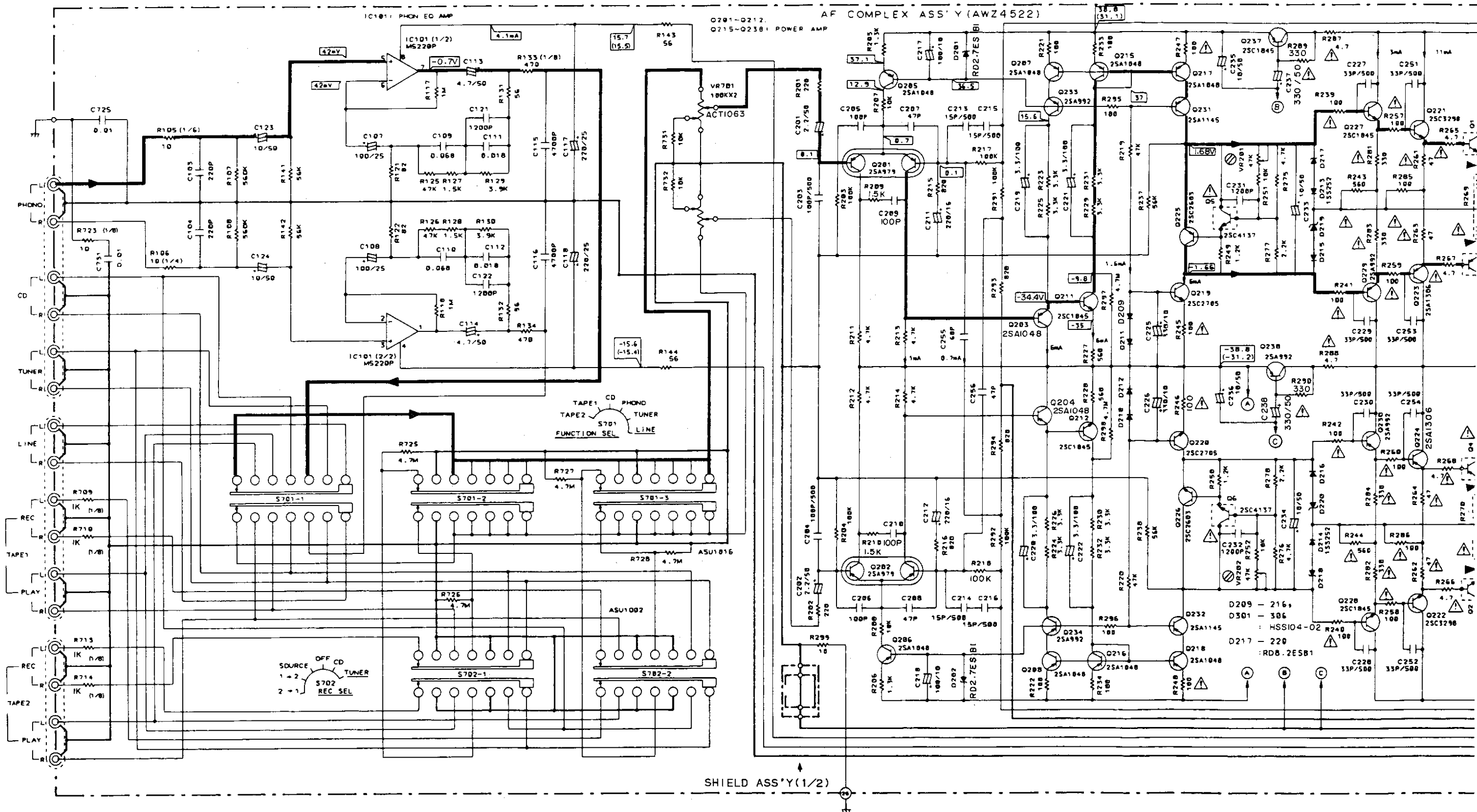

A

B

C

D

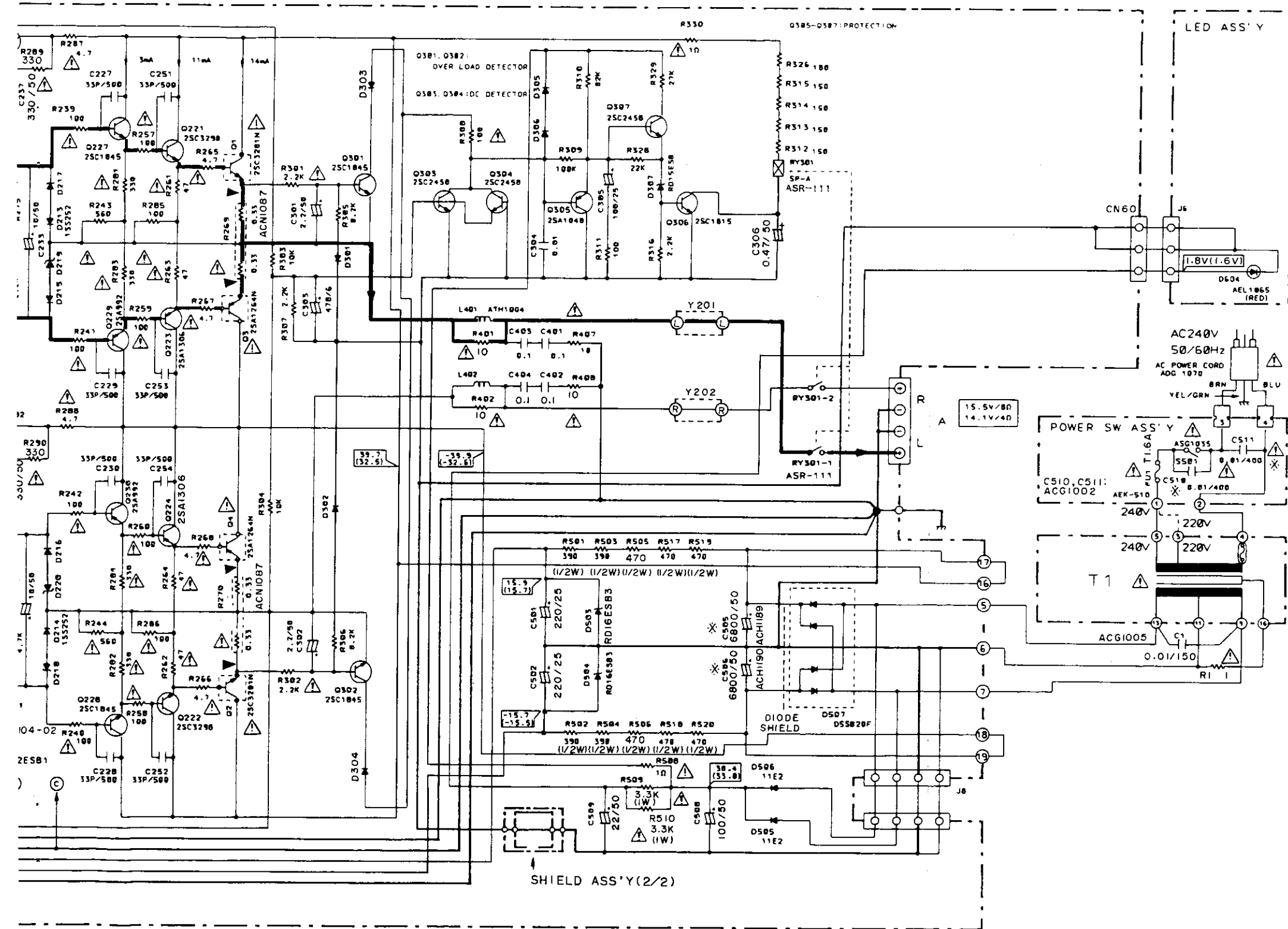

- Note:** (Type 1)
- When ordering service parts, be sure to refer to "PARTS LIST of EXPLODED VIEWS" or "PCB PARTS LIST".
  - Since these are basic circuits, some parts of them or the values of some components may be changed for improvement.
  - RESISTORS:**  
Unit: k:kΩ, M:MΩ, or Ω unless otherwise noted.  
Rated power: 1/4W, 1/6W, 1/8W, 1/10W unless otherwise noted.  
Tolerance: (F): ±1%, (G): ±2%, (K): ±10%, (M): ±20% or ±5% unless otherwise noted.
  - CAPACITORS:**  
Unit: p:pF or μF unless otherwise noted.  
Ratings: capacitor (μF)/ voltage (V) unless otherwise noted.  
Rated voltage: 50V except for electrolytic capacitors.
  - COILS:**  
Unit: m:mH or μH unless otherwise noted.
  - VOLTAGE AND CURRENT:**  
    - $\square$  V : Signal voltage at rated output.
    - $\square$  : DC voltage (V) at no input signal unless otherwise noted. Value in ( ) is DC voltage at rated power.
    - $\leftarrow$  mA or  $\rightarrow$  mA : DC current at no input signal unless otherwise noted.
  - OTHERS:**
    - $\bullet \rightarrow$  : Signal route.
    - $\odot$  : Adjusting point.
    - $\blacktriangledown$  (Red) : Measurement point.
    - The  $\Delta$  mark found on some component parts indicates the importance of the safety factor of the parts. Therefore, when replacing, be sure to use parts of identical designation.
  - SWITCHES** (Underline indicates switch position):
    - S501 : POWER SW (ON-OFF)
    - S701 : FUNCTION SEL (TAPE 2 - TAPE 1 - CD - PHONO - TUNER - LINE)
    - S702 : REC SEL (2-1 - 1-2 - SOURCE - OFF - CD - TUNER)

# 4. PCB CONNECTIONS DIAGRAMS

AF COMPLEX ASS'Y (AWZ4522)

A

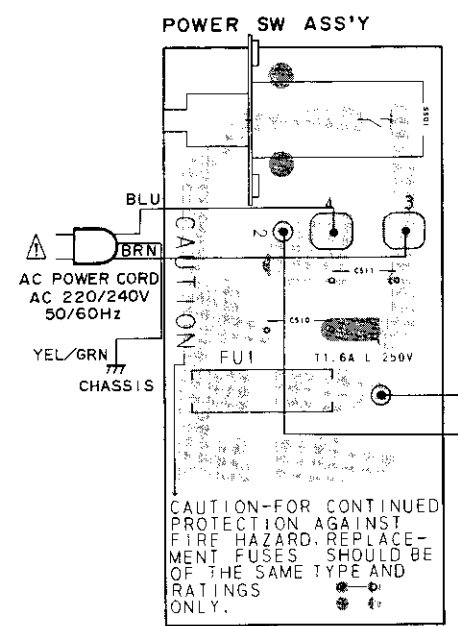

B

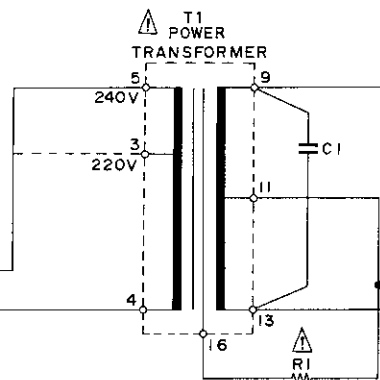

C

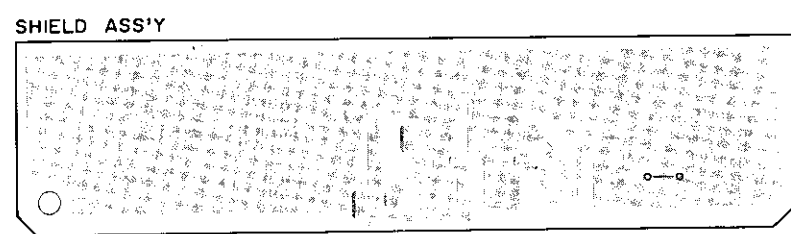

D

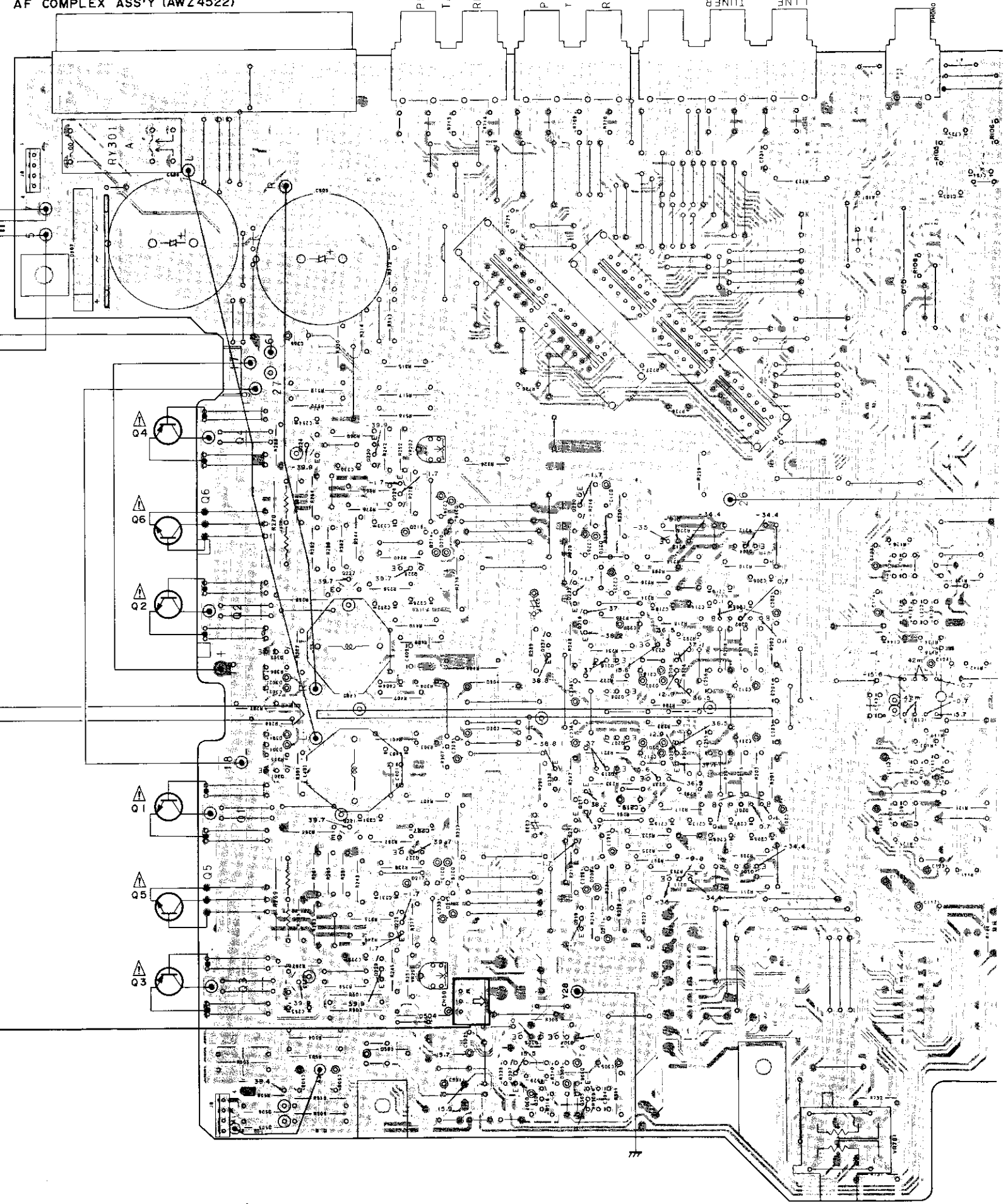
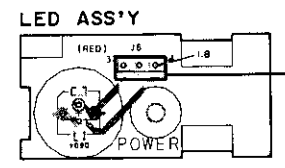

1

2

3

4

5

6



AF COMPLEX ASS'Y (AWZ4522)

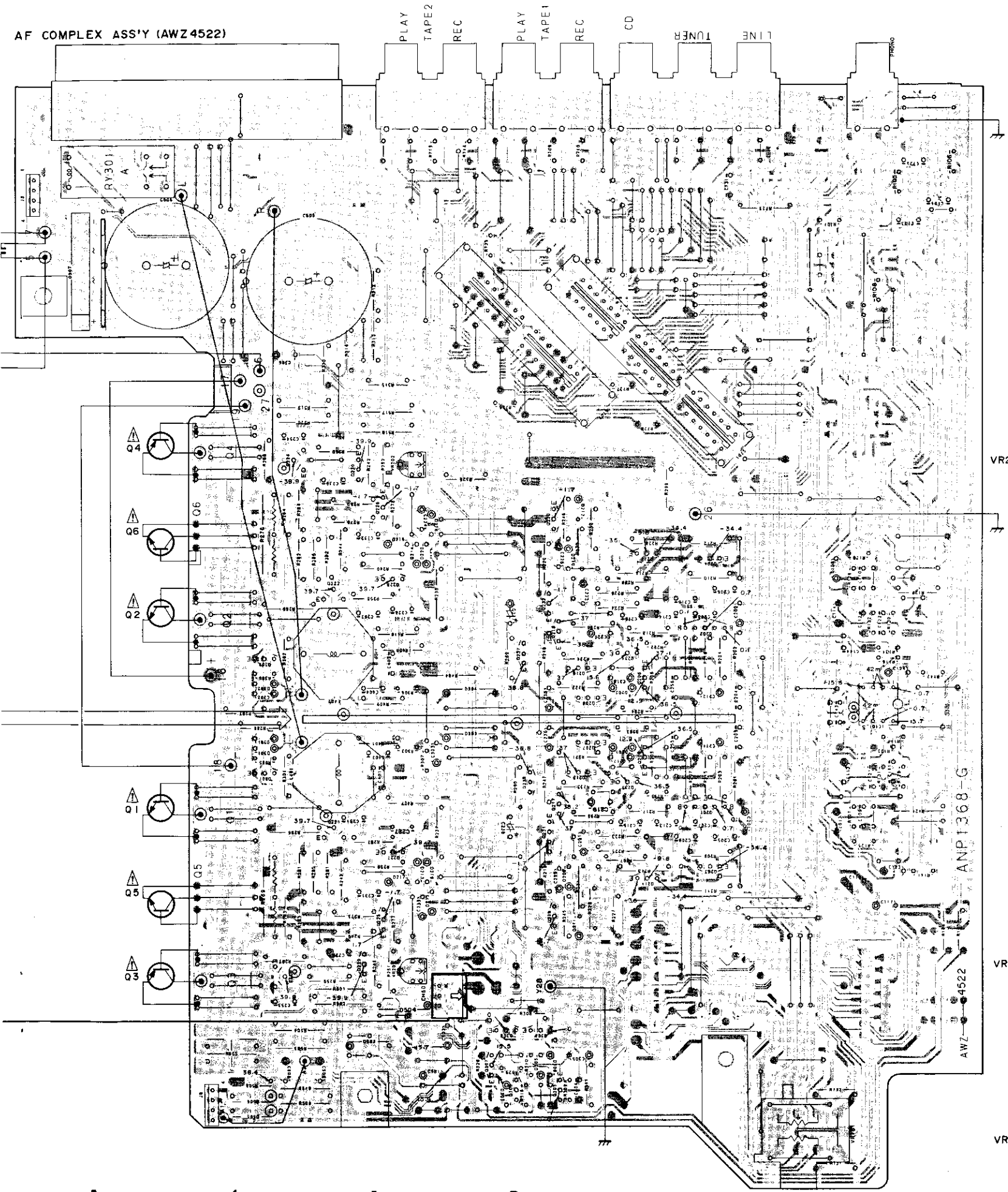

**NOTE**

1. This P.C.B connection diagram is viewed from the parts mounted side.
2. The parts which have been mounted on the board can be replaced with those shown with the corresponding wiring symbols listed in the following Table.

P.C.B. pattern diagram indication	Corresponding part symbol	Part Name
		Transistor
		Radiator type transistor
		Diode
		Resistor
		Capacitor (Polarity)
		Capacitor (Non-polarity)

**Others**

P.C.B. pattern diagram indication	Part Name
IC	IC
S	Switch
RY	Relay
L	Coil
F	Filter
VR	Variable resistor or Semi-fixed resistor

3. The capacitor terminal marked with ⊙ (double circles) shows negative terminal.
4. The diode terminal marked with ⊙ (double circles) shows cathode side.
5. The transistor terminal to which E is affixed shows the emitter.

**Line Voltage Selection**

Line Voltage can be changed as follows :

1. Disconnect the AC power cord.
2. Remove the cover.
3. Change the connection of the power transformer primary taps.
4. Stick the line voltage label on the rear panel.

Part No.	Description
AAX - 193	220 V label
AAX - 192	240 V label

A  
B  
C  
D



This P.C.B. connection diagram is viewed from the foil side.

A  
B  
C  
D

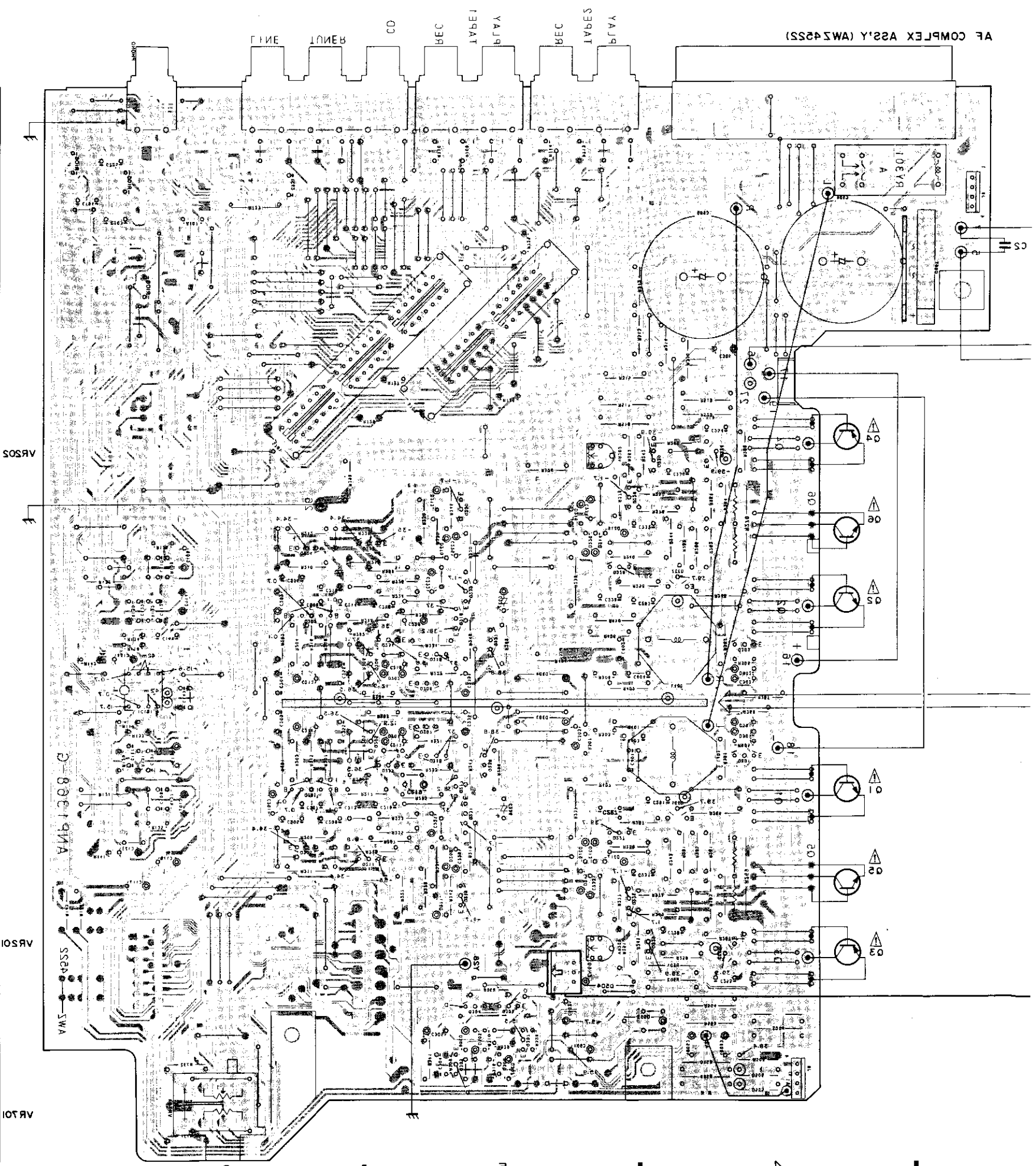

- AR50
- AR51
- AR52
- AR53
- AR54
- AR55
- AR56
- AR57
- AR58
- AR59
- AR60
- AR61
- AR62
- AR63
- AR64
- AR65
- AR66
- AR67
- AR68
- AR69
- AR70
- AR71
- AR72
- AR73
- AR74
- AR75
- AR76
- AR77
- AR78
- AR79
- AR80
- AR81
- AR82
- AR83
- AR84
- AR85
- AR86
- AR87
- AR88
- AR89
- AR90
- AR91
- AR92
- AR93
- AR94
- AR95
- AR96
- AR97
- AR98
- AR99
- AR100

# 4. PCB CONNECTIONS DIAGRAM

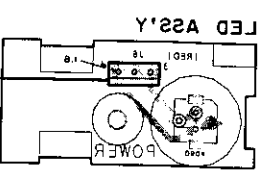
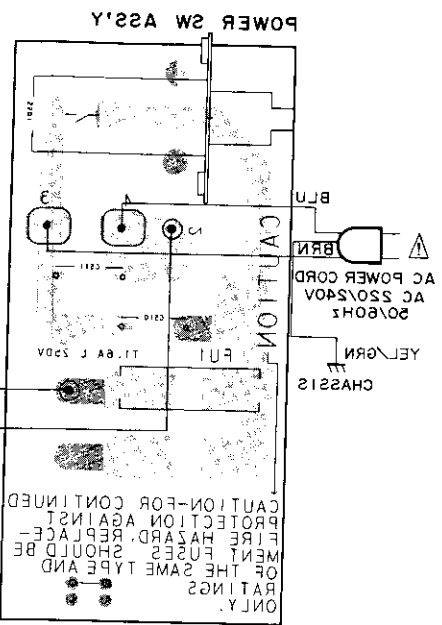
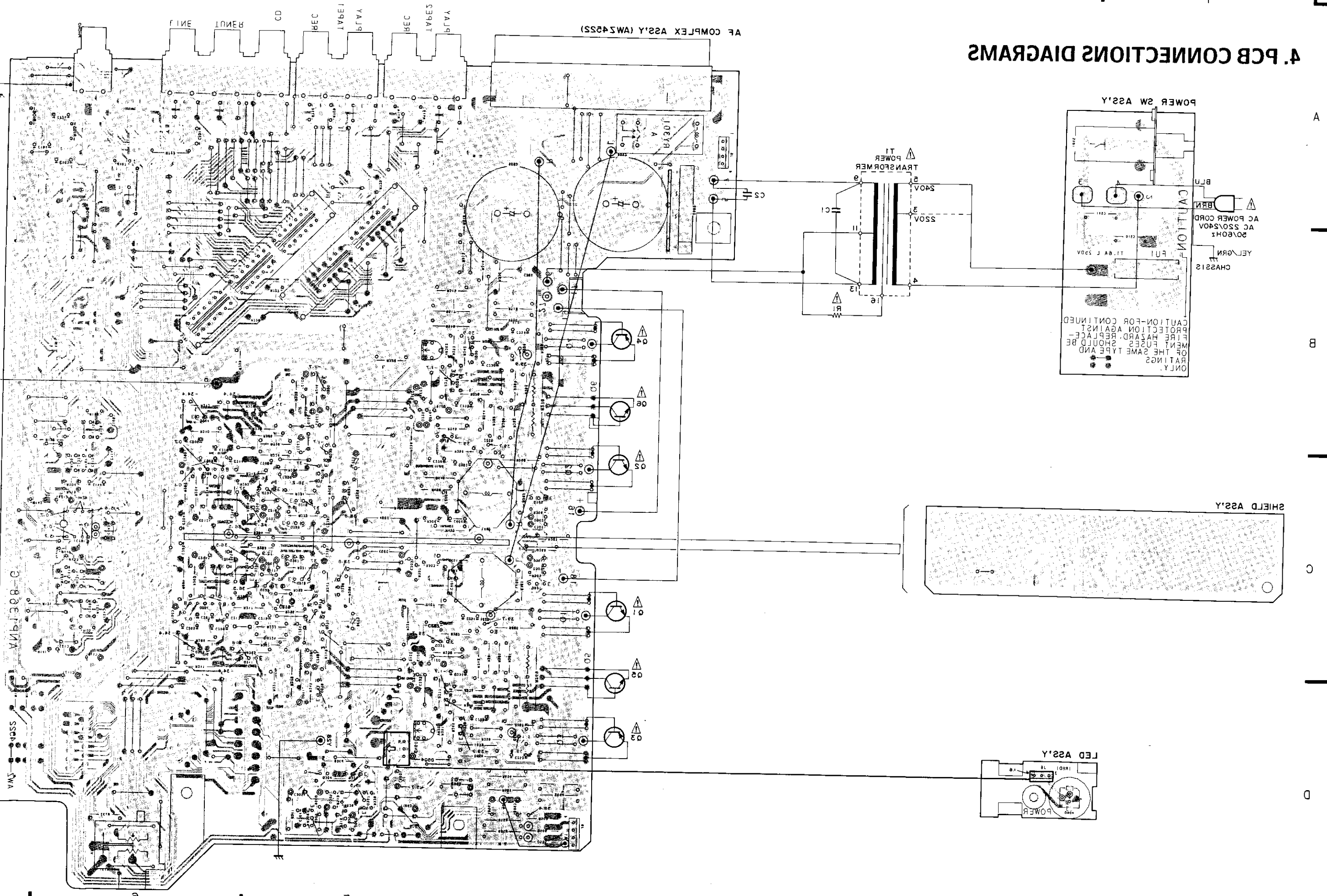

A  
B  
C  
D

1  
2  
3  
4  
5  
6

1  
2  
3  
4  
5  
6

## 5. ADJUSTMENTS

### ADJUSTMENT OF IDLE CURRENT

1. Connect wire as shown in Fig. 5-1.
2. After power ON, aging lasts for 5 mins with no-load.
3. In the Lch VR201 should be adjusted so that both terminal voltages of R269 may attain to 20 mV ( $\pm 3$  mV).
4. In the Rch VR202 should be adjusted so that both terminal voltages may attain to 20 mV ( $\pm 3$  mV).

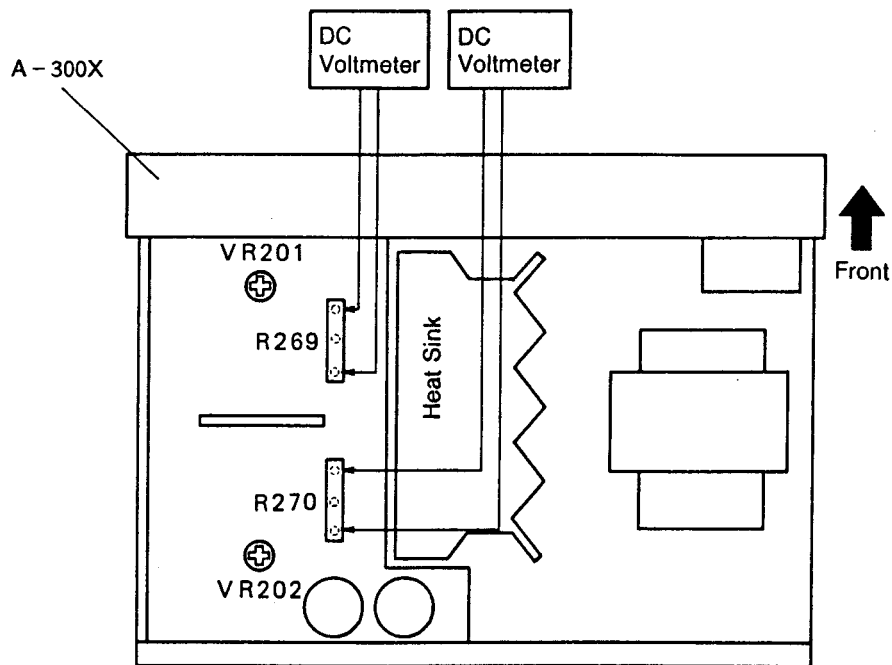
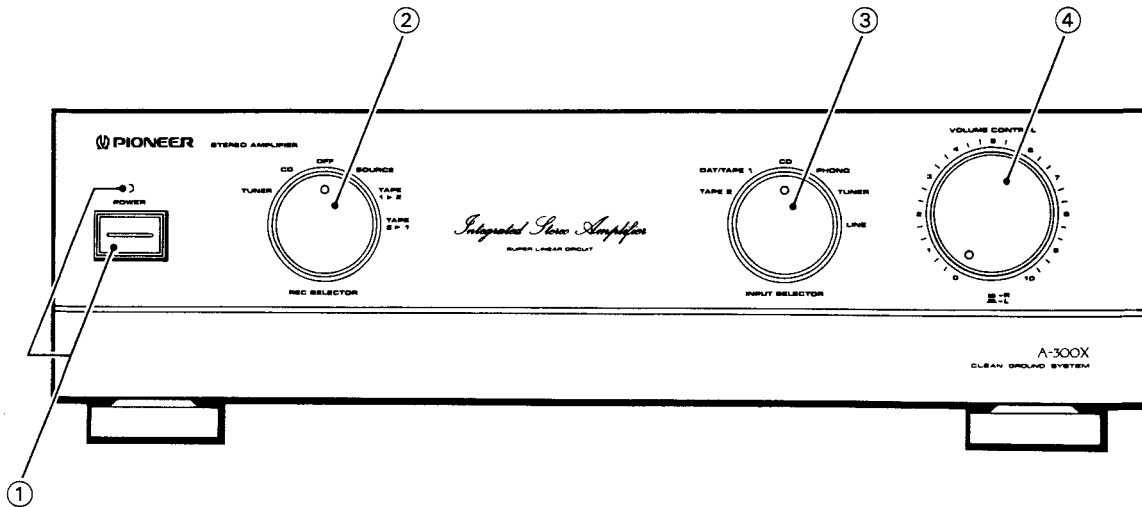

Fig. 5-1 Adjustment Drawing

## 6. PANEL FACILITIES



### ① POWER switch/indicator

Press to turn power to the unit on and off.  
When the power is on, the indicator lights.

### ② REC SELECTOR switch

When this switch is set to a position other than SOURCE or OFF, the equipment selected by REC SELECTOR switch can be recorded from, irrespective of the settings of INPUT SELECTOR.

#### TUNER:

To record from the equipment connected to TUNER terminals.

#### CD:

To record from the equipment connected to CD terminals.

#### OFF:

In this position, nothing from the REC terminals of DAT/TAPE 1 and TAPE 2 is output. Set to this position when not recording; the cassette deck will be disconnected, improving sound quality.

#### SOURCE:

To record from the equipment selected by INPUT SELECTOR switch.

#### TAPE 1 ► 2:

To record (copy) from the cassette deck of DAT/TAPE 1 terminals, to the cassette deck of TAPE 2 terminals.

#### TAPE 2 ► 1:

To record (copy) from the cassette deck of TAPE 2 terminals, to the cassette deck of DAT/TAPE 1 terminals.

### ③ INPUT SELECTOR switch

Use to select the playback source.

#### LINE:

For playback with a component connected to LINE terminal.

#### TUNER:

For AM or FM broadcast reception with a tuner.

#### PHONO:

For record playback with a turntable.

#### CD:

For compact disc playback with a CD player.

#### DAT/TAPE 1:

For playback with a cassette deck or digital audio cassette deck connected to DAT/TAPE 1 terminals.

#### TAPE 2:

For playback with a cassette deck connected to TAPE 2 terminals.

### ④ VOLUME CONTROL

Use to adjust the volume level.

This volume knob consists of two volume controls. Because you can adjust L (left) and R (right) channel volume levels independently, it also functions as a balance control.

#### [Example]

To raise R (right) channel volume level, prevent the L knob from turning with one hand, and turn the R knob with the other hand.

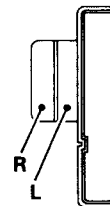

## 7. SPECIFICATIONS

### Amplifier Section

Continuous power output (both channels driven at 20 Hz to 20 kHz)*	
T.H.D. 0.03 %, 8 Ω	30 W + 30 W
T.H.D. 0.05 %, 4 Ω	40 W + 40 W
DIN Continuous power output (both channels driven at 1 kHz)	
T.H.D. 1.0 %, 8 Ω	40 W + 40 W
T.H.D. 1.0 %, 4 Ω	60 W + 60 W
Dynamic power output (on EIA dynamic test signal)	
8 Ω/4 Ω/2 Ω	50 W/75 W/90 W
Total harmonic distortion*	
20 Hz to 20 kHz, 30 W, 8 Ω	0.03 %*
20 Hz to 20 kHz, 40 W, 4 Ω	0.05 %*
Input sensitivity/impedance	
PHONO (MM)	2.5 mV/50 kΩ
CD, TUNER, LINE, TAPE	150 mV/50 kΩ
PHONO overload level	
1 kHz, T.H.D. 0.02 % (MM)	150 mV
Output level/impedance	
TAPE REC	150 mV/1 kΩ
Frequency response	
PHONO (MM)	20 Hz to 20 kHz ±0.3 dB
CD, TUNER, LINE, TAPE	5 Hz to 100 kHz, ±0.5 dB
Signal-to-Noise ratio (IHF short circuit, A network)	
PHONO (MM, 2.5 mV input)	83 dB
CD, TUNER, LINE, TAPE	108 dB
Signal-to-Noise ratio (DIN, continuous power/50 mW)	
PHONO (MM)	73 dB/63 dB
CD, TUNER, LINE, TAPE	88 dB/65 dB

### Power Supply/Miscellaneous

Power requirements	a.c. 240 V ~, 50/60 Hz
Power consumption	410 W
Dimensions	420 (W) x 352 (D) x 126 (H) mm
Weight (without package)	6.8 kg

### Accessories

Operating instructions	1
------------------------	---

- Specifications and design subject to possible modification without notice, due to improvements.

\* Measured by Audio Spectrum Analyzer.