

Service Manual

PIONEER
The Art of Entertainment

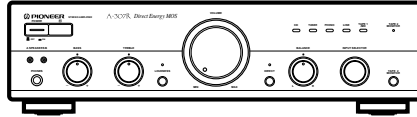

The illustration shows the A-307R.

ORDER NO.
RRV1912

STEREO AMPLIFIER

A-307R

A-207R

THIS MANUAL IS APPLICABLE TO THE FOLLOWING MODEL(S) AND TYPE(S).

Type	Model		Power Requirement	The voltage can be converted by the following method.
	A-307R	A-207R		
MYXJ/EW	○	○	AC220-230V	—
MYXJ/GR	○	○	AC220-230V	—
MVXJ	—	○	AC220-230V	—
SAMXJ	○	—	AC110V/120-127V/220V/240V	With the voltage selector
SDXJ	○	—	AC110V/120-127V/220V/240V	With the voltage selector

CONTENTS

1. SAFETY INFORMATION	2	7. GENERAL INFORMATION	26
2. EXPLODED VIEWS AND PARTS LIST	3	7.1 IC	26
3. SCHEMATIC DIAGRAM	6	7.2 DISASSEMBLY	27
4. PCB CONNECTION DIAGRAM	14	7.3 BLOCK DIAGRAM	28
5. PCB PARTS LIST	22	8. PANEL FACILITIES AND SPECIFICATIONS	29
6. ADJUSTMENT	25		

PIONEER ELECTRONIC CORPORATION 4-1, Meguro 1-Chome, Meguro-ku, Tokyo 153-8654, Japan
PIONEER ELECTRONICS SERVICE, INC. P.O. Box 1760, Long Beach, CA 90801-1760, U.S.A.
PIONEER ELECTRONIC (EUROPE) N.V. Haven 1087, Keetberglaan 1, 9120 Melsele, Belgium
PIONEER ELECTRONICS ASIACENTRE PTE. LTD. 501 Orchard Road, #10-00 Lane Crawford Place, Singapore 0923
 © PIONEER ELECTRONIC CORPORATION 1998

T - IZK APR. 1998 Printed in Japan

1. SAFETY INFORMATION

This service manual is intended for qualified service technicians ; it is not meant for the casual do-it-yourselfer. Qualified technicians have the necessary test equipment and tools, and have been trained to properly and safely repair complex products such as those covered by this manual.

Improperly performed repairs can adversely affect the safety and reliability of the product and may void the warranty. If you are not qualified to perform the repair of this product properly and safely, you should not risk trying to do so and refer the repair to a qualified service technician.



WARNING

Lead in solder used in this product is listed by the California Health and Welfare agency as a known reproductive toxicant which may cause birth defects or other reproductive harm (California Health & Safety Code, Section 25249.5).

When servicing or handling circuit boards and other components which contain lead in solder, avoid unprotected skin contact with the solder. Also, when soldering do not inhale any smoke or fumes produced.



NOTICE

(FOR CANADIAN MODEL ONLY)

Fuse symbols  (fast operating fuse) and/or  (slow operating fuse) on PCB indicate that replacement parts must be of identical designation.

REMARQUE

(POUR MODÈLE CANADIEN SEULEMENT)

Les symboles de fusible  (fusible de type rapide) et/ou  (fusible de type lent) sur CCI indiquent que les pièces de remplacement doivent avoir la même désignation.

(FOR USA MODEL ONLY)

1. SAFETY PRECAUTIONS

The following check should be performed for the continued protection of the customer and service technician.

LEAKAGE CURRENT CHECK

Measure leakage current to a known earth ground (water pipe, conduit, etc.) by connecting a leakage current tester such as Simpson Model 229-2 or equivalent between the earth ground and all exposed metal parts of the appliance (input/output terminals, screwheads, metal overlays, control shaft, etc.). Plug the AC line cord of the appliance directly into a 120V AC 60Hz outlet and turn the AC power switch on. Any current measured must not exceed 0.5mA.

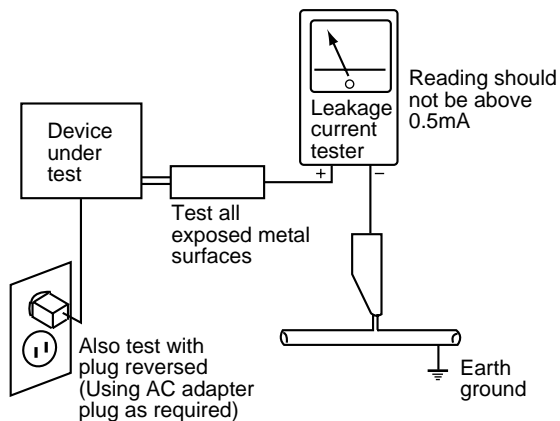

AC Leakage Test

ANY MEASUREMENTS NOT WITHIN THE LIMITS OUTLINED ABOVE ARE INDICATIVE OF A POTENTIAL SHOCK HAZARD AND MUST BE CORRECTED BEFORE RETURNING THE APPLIANCE TO THE CUSTOMER.

2. PRODUCT SAFETY NOTICE

Many electrical and mechanical parts in the appliance have special safety related characteristics. These are often not evident from visual inspection nor the protection afforded by them necessarily can be obtained by using replacement components rated for voltage, wattage, etc. Replacement parts which have these special safety characteristics are identified in this Service Manual.

Electrical components having such features are identified by marking with a Δ on the schematics and on the parts list in this Service Manual.

The use of a substitute replacement component which does not have the same safety characteristics as the PIONEER recommended replacement one, shown in the parts list in this Service Manual, may create shock, fire, or other hazards.

Product Safety is continuously under review and new instructions are issued from time to time. For the latest information, always consult the current PIONEER Service Manual. A subscription to, or additional copies of, PIONEER Service Manual may be obtained at a nominal charge from PIONEER.

2. EXPLODED VIEWS AND PARTS LIST

- NOTES: ● Parts marked by "NSP" are generally unavailable because they are not in our Master Spare Parts List.
 ● The Δ mark found on some component parts indicates the importance of the safety factor of the part. Therefore, when replacing, be sure to use parts of identical designation.
 ● Screws adjacent to \blacktriangledown mark on the product are used for disassembly.

2.1 PACKING

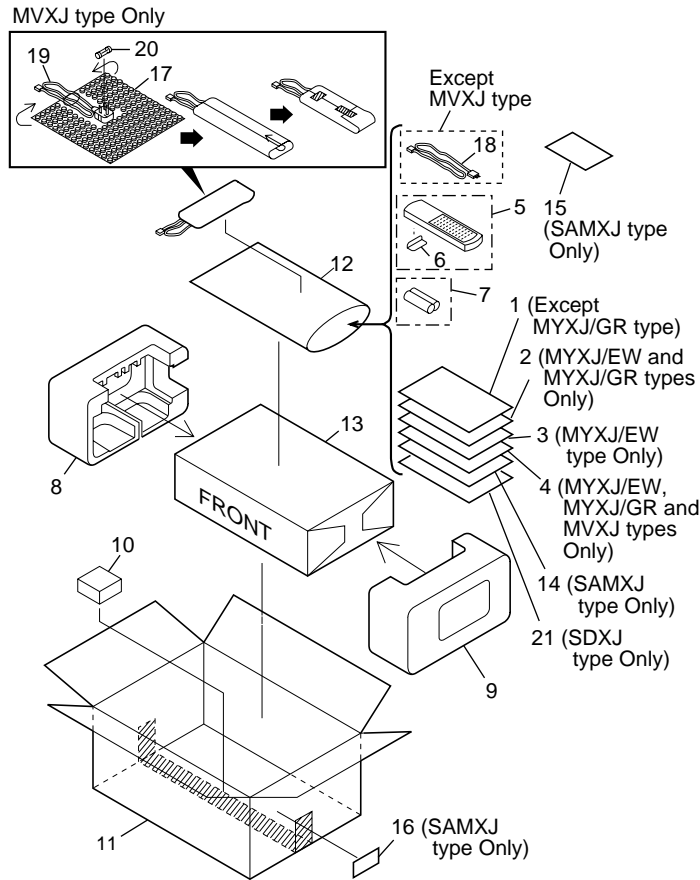

(1) PACKING PARTS LIST

Mark	No.	Description	Part No.
	1	Operating Instructions (English)	See Contrast table(2)
	2	Operating Instructions (German)	See Contrast table(2)
	3	Operating Instructions (French/Italian/Dutch/Swedish/Spanish/Portugese)	See Contrast table(2)
NSP	4	Warranty Card	See Contrast table(2)
	5	Remote Control Unit (CU-A014)	AXD7163
	6	Battery Cover	AZN2249
NSP	7	Dry Cell Battery (R6P,AA)	VEM-013
	8	Side Pad L	AHA7205
	9	Side Pad R	AHA7206
	10	Sub Pad	AHA7218
	11	Packing Case	See Contrast table(2)
NSP	12	Literature Bag	AHG1180
	13	Packing Sheet	AHG7015
	14	Operating Instructions (Chinese)	See Contrast table(2)
	15	Caution Label 220V	See Contrast table(2)
	16	Case Label	See Contrast table(2)
NSP	17	Air Cap	See Contrast table(2)
Δ	18	Power Cord	See Contrast table(2)
Δ	19	Power Cord with Fuse	See Contrast table(2)
Δ	20	Fuse (T5A)	See Contrast table(2)
	21	Operating Instructions (Spanish/Chinese)	See Contrast table(2)

(2) CONTRAST TABLE

A-307R/MYXJ/EW, MYXJ/GR, SAMXJ, SDXJ, A-207R/MYXJ/EW, MYXJ/GR and MVXJ are constructed the same except for the following :

Mark	No.	Symbol and Description	Part No.						Remarks
			A-307R				A-207R		
			MYXJ/EW	MYXJ/GR	SAMXJ	SDXJ	MYXJ/EW	MYXJ/GR	
NSP	1	Operating Instructions (English)	ARB7138	Not used	ARB7142	ARB7142	ARB7138	Not used	ARB7138
	2	Operating Instructions (German)	ARC7183	ARC7183	Not used	ARC7183	ARC7183	Not used	Not used
	3	Operating Instructions (French/Italian/Dutch/Swedish/Spanish/Portugese)	ARC7184	Not used	Not used	Not used	ARC7184	Not used	Not used
	4	Warranty Card	ARY7009	ARY7009	Not used	Not used	ARY7009	ARY7009	ARY7009
NSP	11	Packing Case	AHD7563	AHD7563	AHD7581	AHD7564	AHD7561	AHD7561	AHD7561
	14	Operating Instructions (Chinese)	Not used	Not used	ARC7186	Not used	Not used	Not used	Not used
	15	Caution Label 220V	Not used	Not used	ARR1003	Not used	Not used	Not used	Not used
	16	Case Label	Not used	Not used	ARW7032	Not used	Not used	Not used	Not used
	17	Air Cap	Not used	Not used	Not used	Not used	Not used	Not used	AHG1087
Δ	18	Power Cord	ADG1154	ADG1154	ADG7018	ADG1158	ADG1154	ADG1154	Not used
Δ	19	Power Cord with Fuse	Not used	Not used	Not used	Not used	Not used	Not used	ADG1156
Δ	20	Fuse (T5A)	Not used	Not used	Not used	Not used	Not used	Not used	AEK1046
	21	Operating Instructions (Spanish/Chinese)	Not used	Not used	Not used	ARC7185	Not used	Not used	Not used

2.2 EXTERIOR

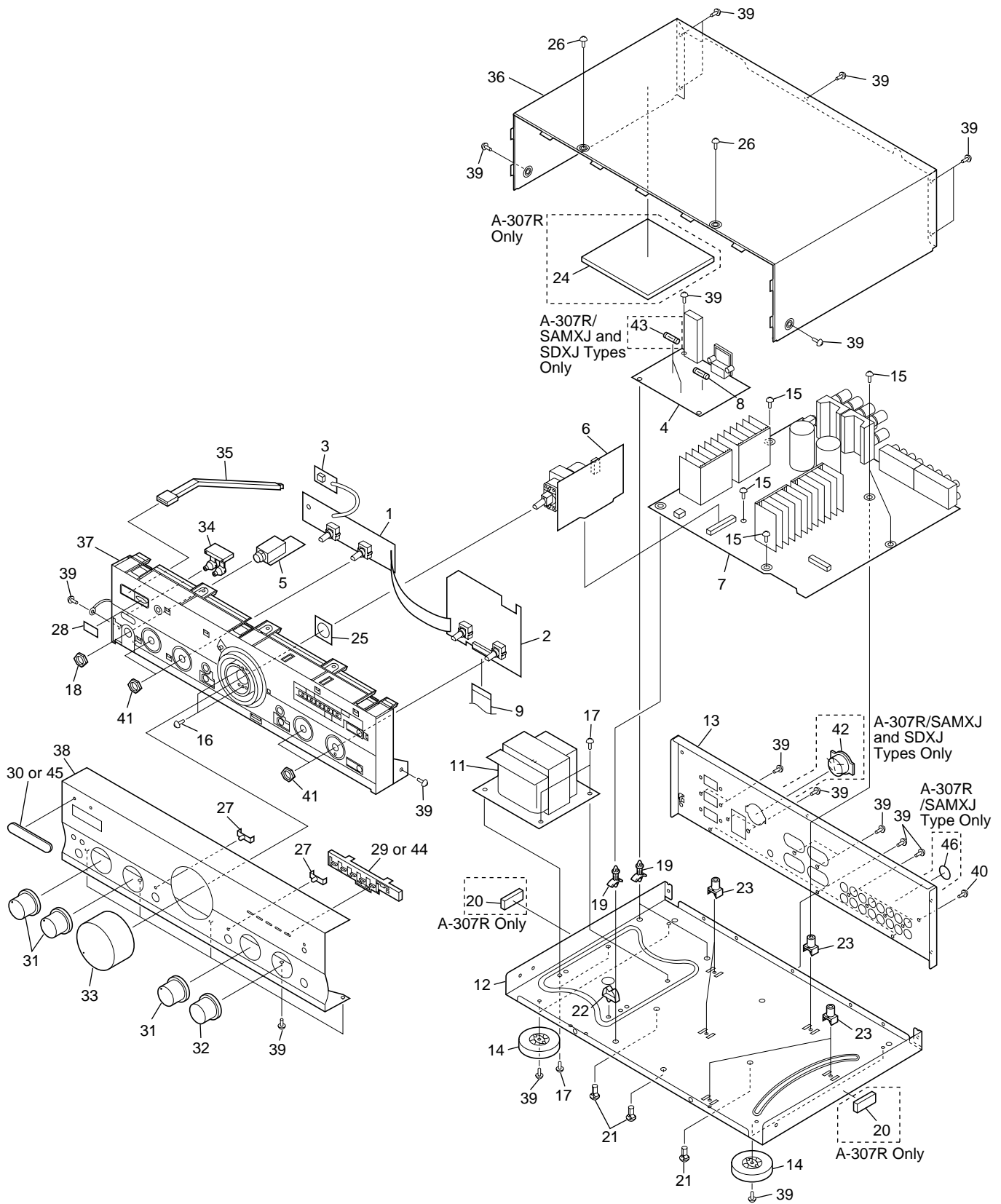

(1) EXTERIOR PARTS LIST

Mark	No.	Description	Part No.	Mark	No.	Description	Part No.
	1	FRONT L Assy	AWX7123		26	Screw	PBA1096
	2	FRONT R Assy	AWX7124		27	LED Lens	AAK2459
	3	OPT Assy	AWX7125		28	IR Filter	AAK7532
NSP	4	AC PRIMARY Assy	See Contrast table(2)		29	LED Lens T	See Contrast table(2)
	5	HEADPHONE Assy	AWX7114		30	Name Plate	See Contrast table(2)
	6	VOLUME Assy	AWX7118		31	Rotary Knob A	AAB7148
△	7	AF Assy	See Contrast table(2)		32	Rotary Knob B	AAB7149
	8	Fuse (FU1)	See Contrast table(2)		33	Volume Knob	AAB7150
	9	Flexible Cable (19P) (AF CN202-FRONT R CN601)	ADD7032		34	Speaker Button	AAD7435
	10	•••••			35	Power Joint	AAD7439
△	11	Power Transformer (T1)	See Contrast table(2)		36	Bonnet Case	ANE7183
NSP	12	Chassis	ANA7064		37	Panel Base	AMB7489
	13	Rear Panel	See Contrast table(2)		38	Front Panel	See Contrast table(2)
	14	Insulator	PNW2766		39	Screw	BBZ30P080FZK
	15	Screw	ABA1018		40	Screw	BCZ30P060FCC
	16	Screw	ABA1027		41	Nut	NK90FUC
	17	Screw (4 × 10)	ABA7047	△	42	Voltage Selector (S2)	See Contrast table(2)
	18	Nut	ABN-065	△	43	Fuse (FU2, FU3 : 2A)	See Contrast table(2)
	19	PCB Support	AEC7006		44	LED Lens A	See Contrast table(2)
	20	Rubber Spacer	See Contrast table(2)		45	PIONEER Badge	See Contrast table(2)
NSP	21	PCB Holder	AEC7057		46	Label (Rear Base)	See Contrast table(2)
NSP	22	Cord Clamp F	AEC7134				
	23	PCB Mold	AMR2533				
NSP	24	Damping Plate	See Contrast table(2)				
NSP	25	Shield Plate	ANK7043				

(2) CONTRAST TABLE

A-307R/MYXJ/EW, MYXJ/GR, SAMXJ, SDXJ, A-207R/MYXJ/EW, MYXJ/GR and MVXJ are constructed the same except for the following :

Mark	No.	Symbol and Description	Part No.						Remarks	
			A-307R				A-207R			
			MYXJ/EW	MYXJ/GR	SAMXJ	SDXJ	MYXJ/EW	MYXJ/GR		MVXJ
	4	AC PRIMARY Assy	AWX7113	AWX7113	AWX7115	AWX7115	AWX7113	AWX7113	AWX7113	
	7	AF Assy	AWX7119	AWX7119	AWX7119	AWX7119	AWX7117	AWX7117	AWX7117	
△	8	Fuse (FU1 : 2A)	REK1025	REK1025	Not used	Not used	Not used	Not used	Not used	
△	8	Fuse (FU1 : 2.5A)	Not used	Not used	REK1026	Not used	Not used	Not used	Not used	
△	8	Fuse (FU1 : 6.3A)	Not used	Not used	Not used	REK1030	Not used	Not used	Not used	
△	8	Fuse (FU1 : 1.25A)	Not used	Not used	Not used	Not used	REK1023	REK1023	REK1023	
△	11	Power Transformer (T1 : AC220-230V)	ATS7188	ATS7188	Not used	Not used	ATS7190	ATS7190	ATS7190	
△	11	Power Transformer (T1 : AC110V/120-127V/220V/240V)	Not used	Not used	ATS7189	ATS7189	Not used	Not used	Not used	
	13	Rear Panel	ANC7643	ANC7643	ANC7645	ANC7644	ANC7639	ANC7639	ANC7639	
	20	Rubber Spacer	AEC7034	AEC7034	AEC7034	AEC7034	Not used	Not used	Not used	
NSP	24	Damping Plate	AMR7216	AMR7216	AMR7216	AMR7216	Not used	Not used	Not used	
	29	LED Lens T	AAK7544	AAK7544	AAK7544	AAK7544	Not used	Not used	Not used	
	30	Name Plate	AAM7004	AAM7004	AAM7004	AAM7004	Not used	Not used	Not used	
	38	Front Panel	ANB7114	ANB7114	ANB7114	ANB7114	AMB7493	AMB7493	AMB7493	
△	42	Voltage Selector (S2)	Not used	Not used	AKX-507	AKX-507	Not used	Not used	Not used	
△	43	Fuse (FU2, FU3 : 2A)	Not used	Not used	REK1025	REK1025	Not used	Not used	Not used	
	44	LED Lens A	Not used	Not used	Not used	Not used	AAK7537	AAK7537	AAK7537	
	45	PIONEER Badge	Not used	Not used	Not used	Not used	PAM1755	PAM1755	PAM1755	
	46	Label (Rear Base)	Not used	Not used	PRW1499	Not used	Not used	Not used	Not used	

3. SCHEMATIC DIAGRAM

3.1 OVERALL CONNECTION DIAGRAM

A

B

C

D

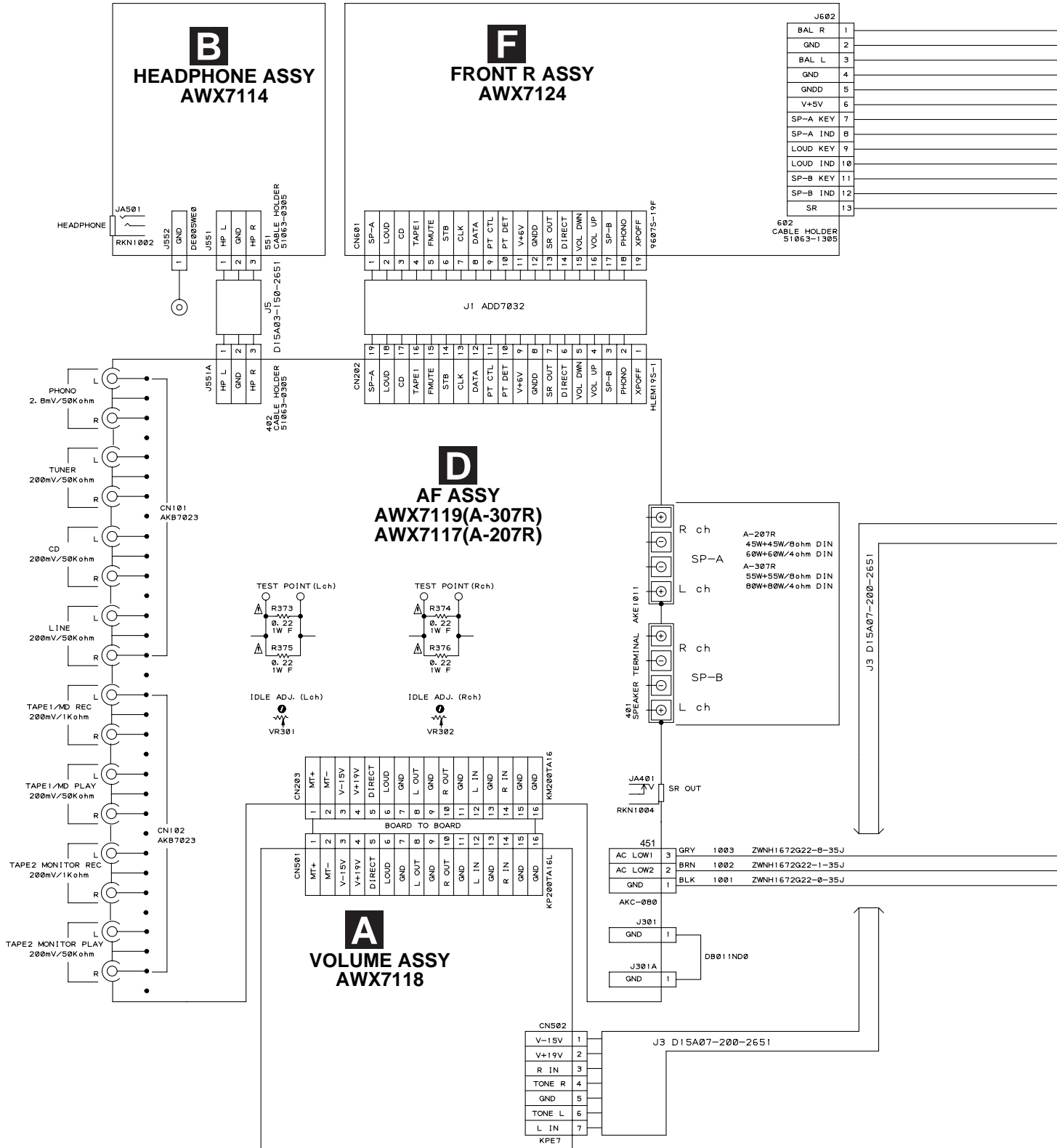

Note : When ordering service parts, be sure to refer to "EXPLODED VIEWS and PARTS LIST" or "PCB PARTS LIST".

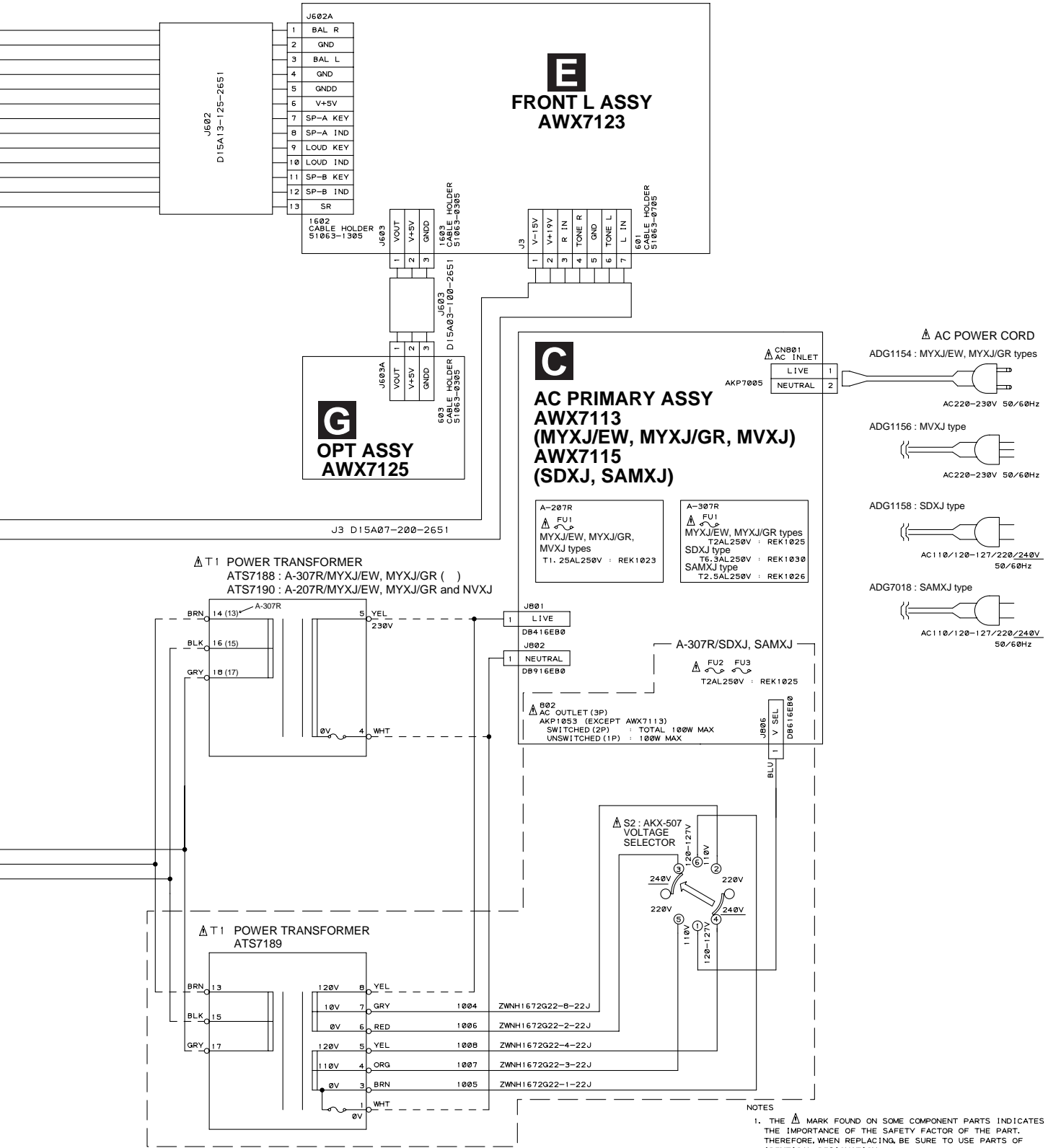

3.2 VOLUME AND HEADPHONE ASSEMBLIES

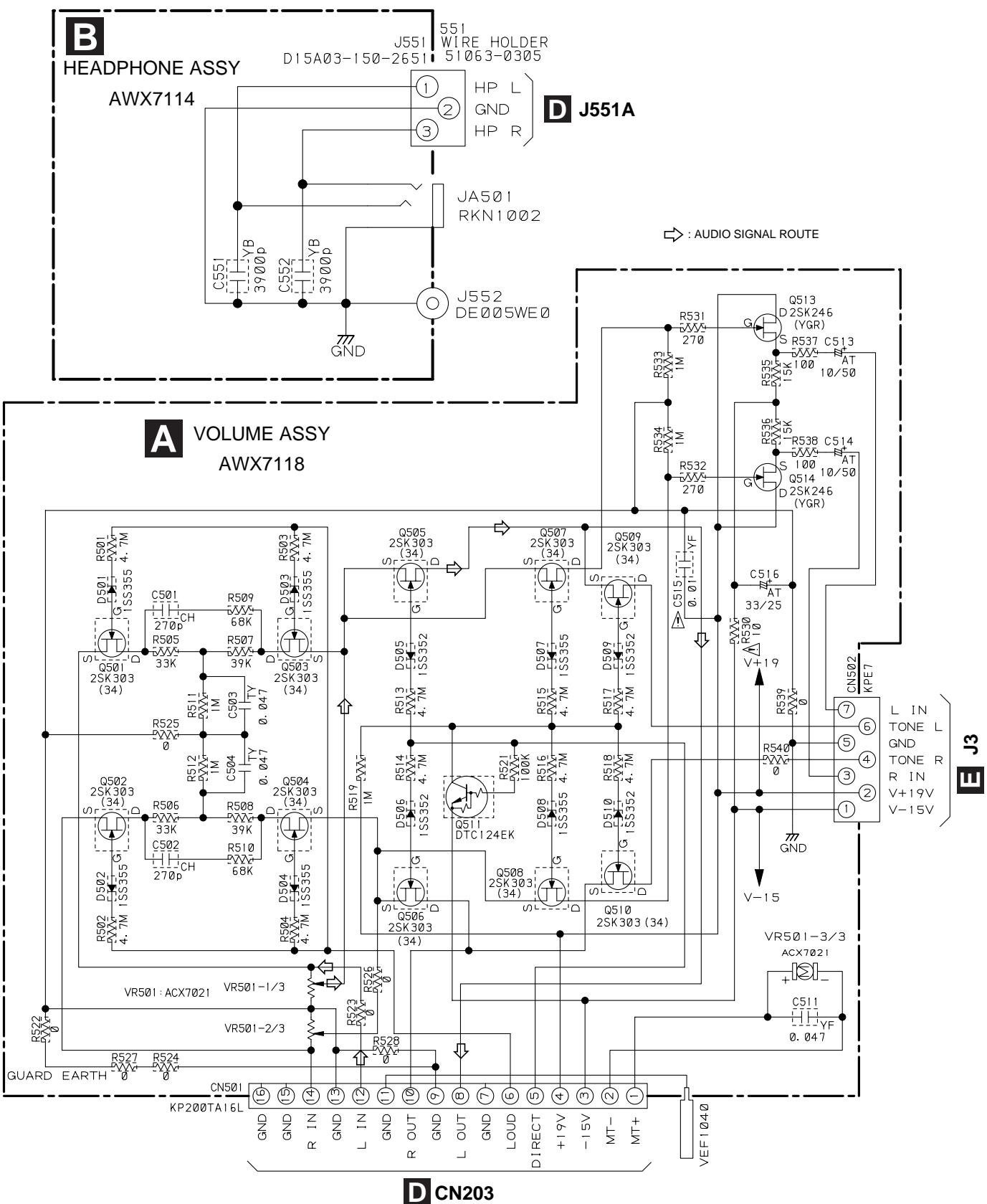

3.3 AC PRIMARY ASSY

• NOTE FOR FUSE REPLACEMENT

CAUTION -FOR CONTINUED PROTECTION AGAINST RISK OF FIRE. REPLACE WITH SAME TYPE AND RATINGS ONLY.

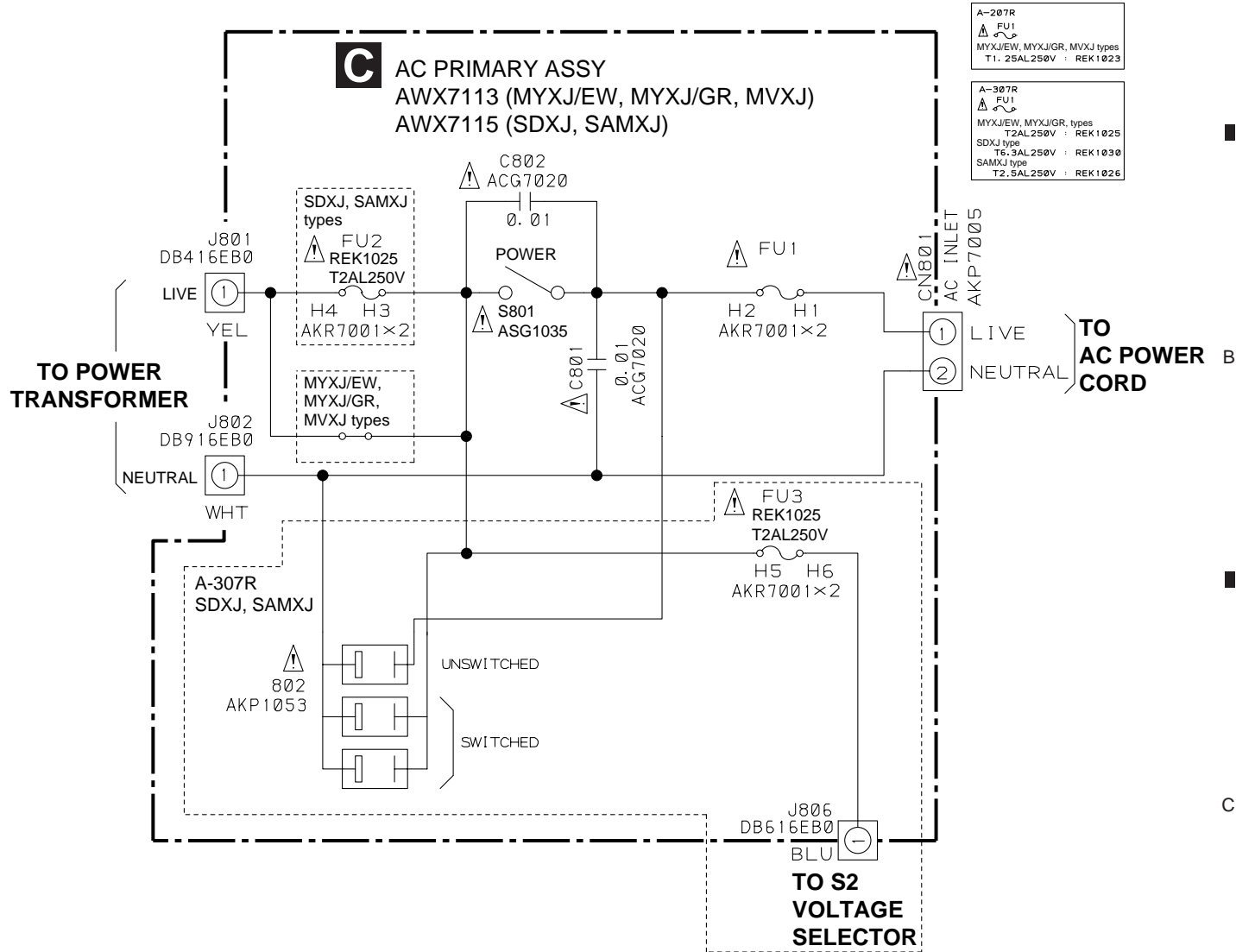

NOTES

1. RESISTORS
INDICATED IN Ohm 1/10W 5% TOLERANCE UNLESS OTHERWISE NOTED
k : kOhm, M : MOhm
2. CAPACITORS
INDICATED IN CAPACITY (uF) /VOLTAGE (V) UNLESS OTHERWISE NOTED p : pF
INDICATED WITHOUT VOLTAGE IS 50V EXCEPT ELECTROLYTIC CAPACITOR.
TY : CFTYA, CH : CCSQCH, YB : CKSQYB, YF : CKSQYF
3. THE MARK FOUND ON SOME COMPONENT PARTS INDICATES THE IMPORTANCE OF THE SAFETY FACTOR OF THE PART. THEREFORE, WHEN REPLACING, BE SURE TO USE PARTS OF IDENTICAL DESIGNATION.



3.4 AF ASSY

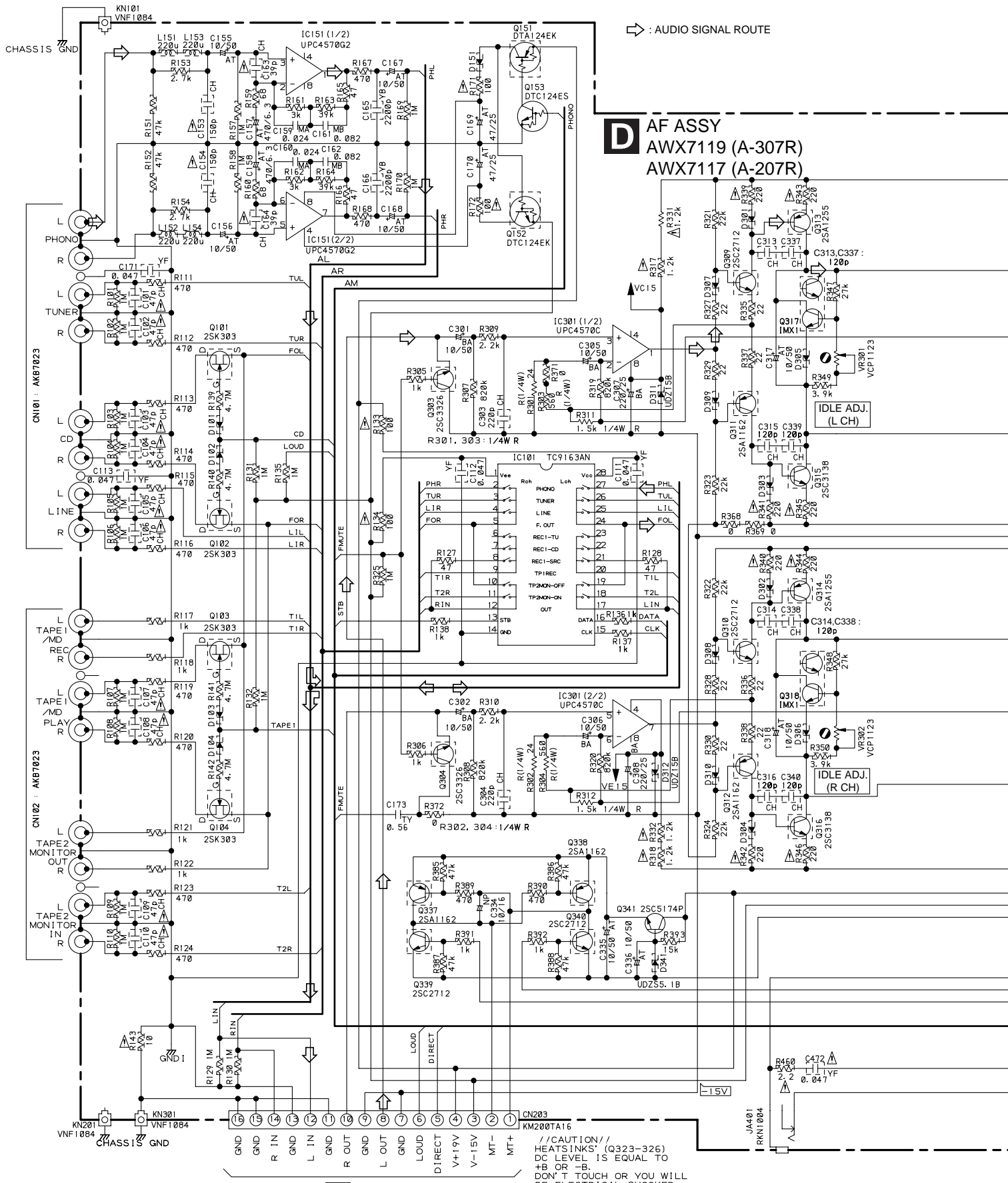

AF ASSY
AWX719 (A-307R)
AWX717 (A-207R)

//CAUTION//
HEATSINKS (Q323-326)
DC LEVEL IS EQUAL TO
+B OR -B.
DON'T TOUCH OR YOU WILL
BE ELECTRICAL SHOCKED.

CN501

NOTES

1. RESISTORS

INDICATED IN Ohm 1/10W ±5% TOLERANCE UNLESS OTHERWISE NOTED
k: kOhm, M: Mohm, F: NON-FRAMABLE TYPE, R: RDR TYPE

2. CAPACITORS

INDICATED IN CAPACITY (uF) / VOLTAGE (V) UNLESS OTHERWISE NOTED p: pF
INDICATED WITHOUT VOLTAGE IS 50V EXCEPT ELECTROLYTIC CAPACITOR.

MA: CGMA, MB: CGMA, TY: CFTYA, CH: CCSGH, SL: CCSGL, YB: CKSQB, YF: CKSQF

3. INDUCTORS

INDICATED IN H ±5%

4. DIODES

NO MARK DIODES ARE 1SS355

5. VOLTAGE

INDICATED IN DC VOLTAGE: NO SIGNAL/NO POWER OUTPUT
(A-D3: NO SIGNAL/80W*2ch 40hm)

6. THE ▲ MARK FOUND ON SOME COMPONENT PARTS INDICATES THE IMPORTANCE OF THE SAFETY FACTOR OF THE PART. THEREFORE, WHEN REPLACING, BE SURE TO USE PARTS OF IDENTICAL DESIGNATION.

7. TRANSISTOR'S RANK

25C313B: (OY) 25C2712: (OY) 25C3326: (AB)
25A1255: (OY) 25A1162: (OY) 25K303: (34)

CAUTION: FOR CONTINUED PROTECTION AGAINST RISK OF FIRE, REPLACE ONLY WITH SAME TYPE NO. 491001 MFD, BY LITTELFUSE INK. FOR IC454 (AEK7009).

	A-307R	A-207R
C451	ACH7048 (10000/42)	ACH7080 (6800/42)
C452	ACH7049 (10000/42)	ACH7081 (6800/42)

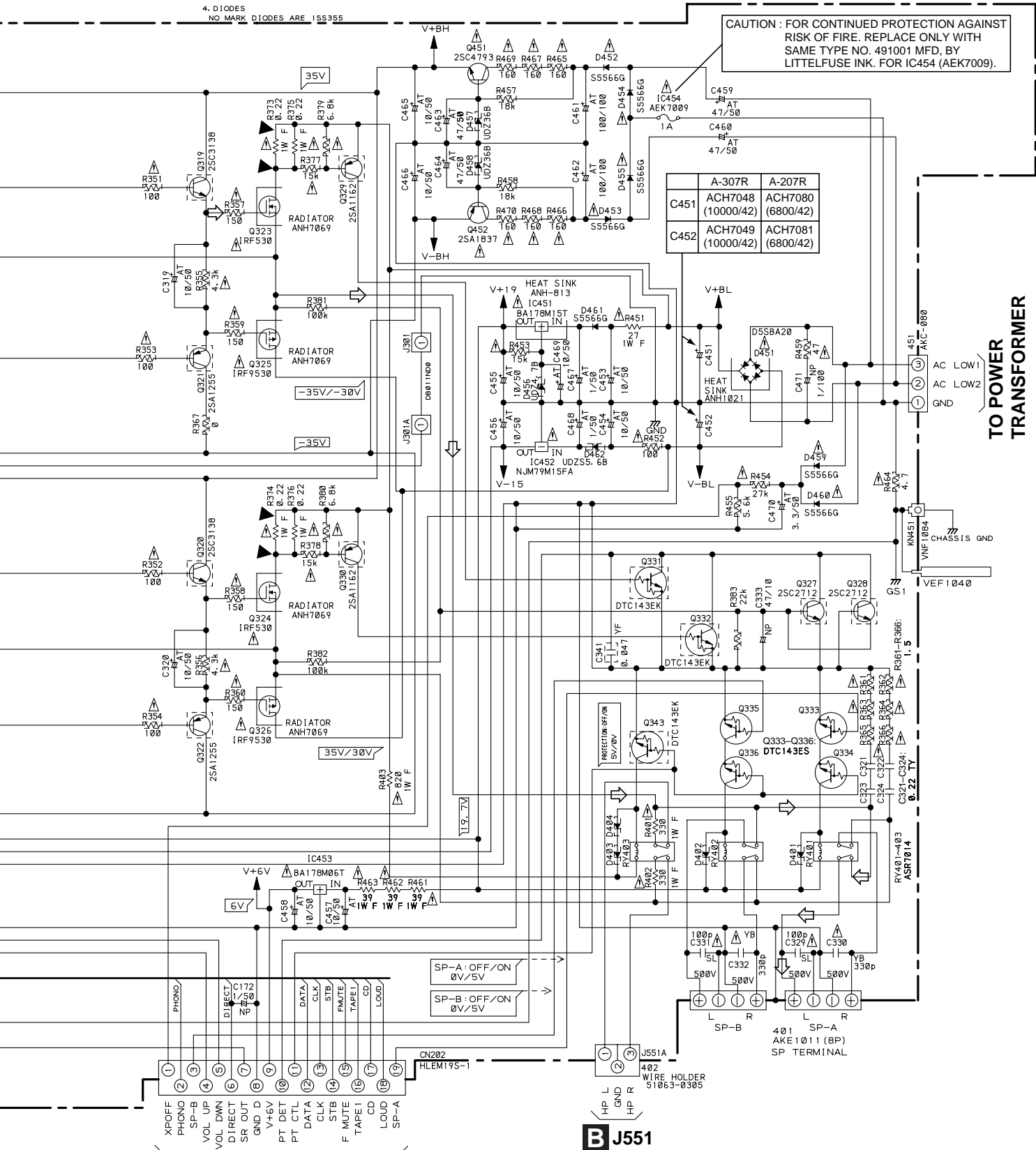

TO POWER TRANSFORMER

- XPOFF
- PHONO
- SP-B
- VOL UP
- VOL DOWN
- DIRECT
- SR OUT
- GND D
- V+5V
- PT CTL
- DATA
- CLK
- STB
- F MUTE
- TAPE1
- CD
- LOUD
- SP-A

F CN601

B J551

D

3.5 FRON L, FRONT R AND OPT ASSEMBLIES

A

B

C

D

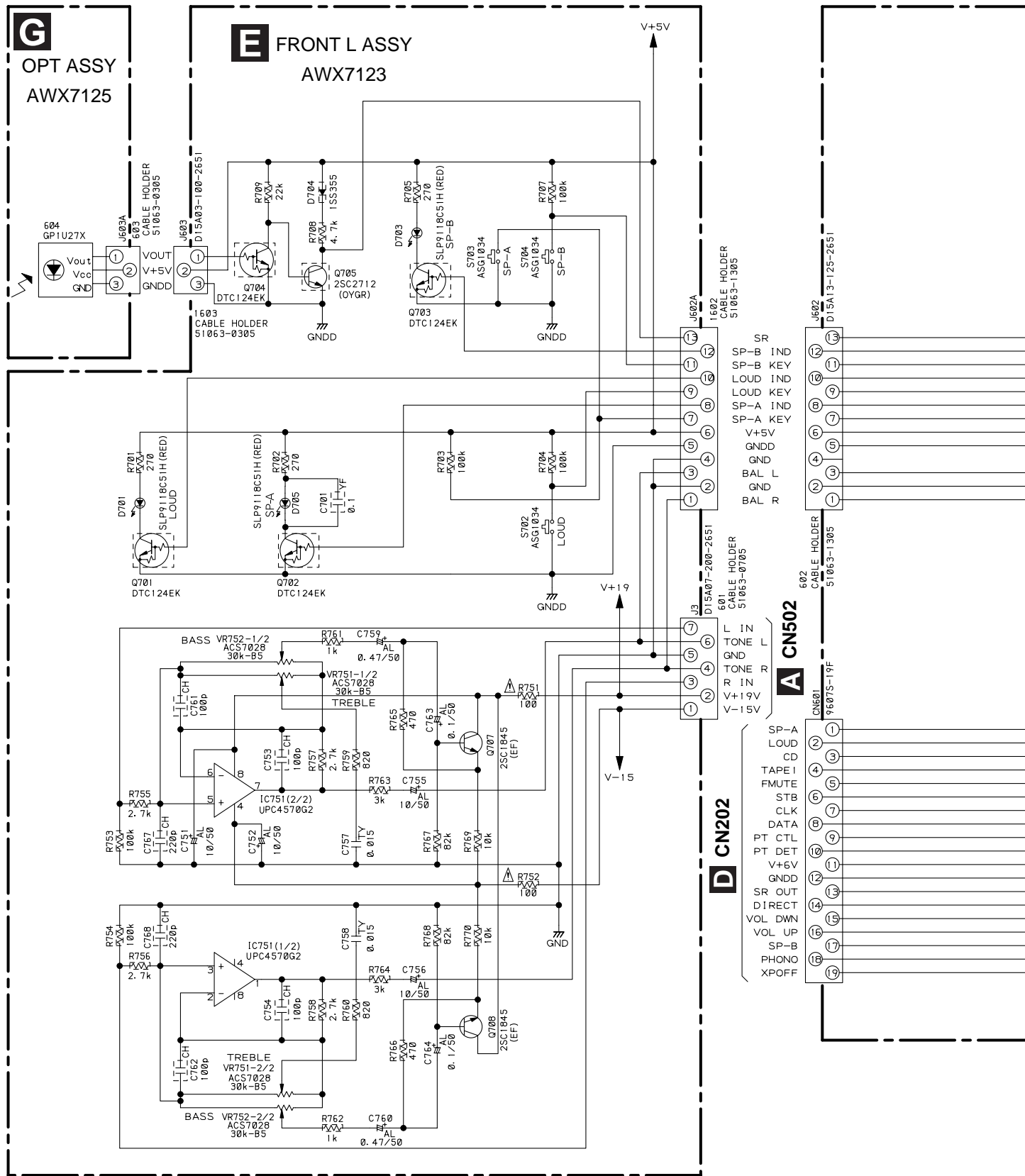

FRONT L ASSY
 S702 : LOUDNESS
 S703 : SPEAKER A
 S704 : SPEAKER B



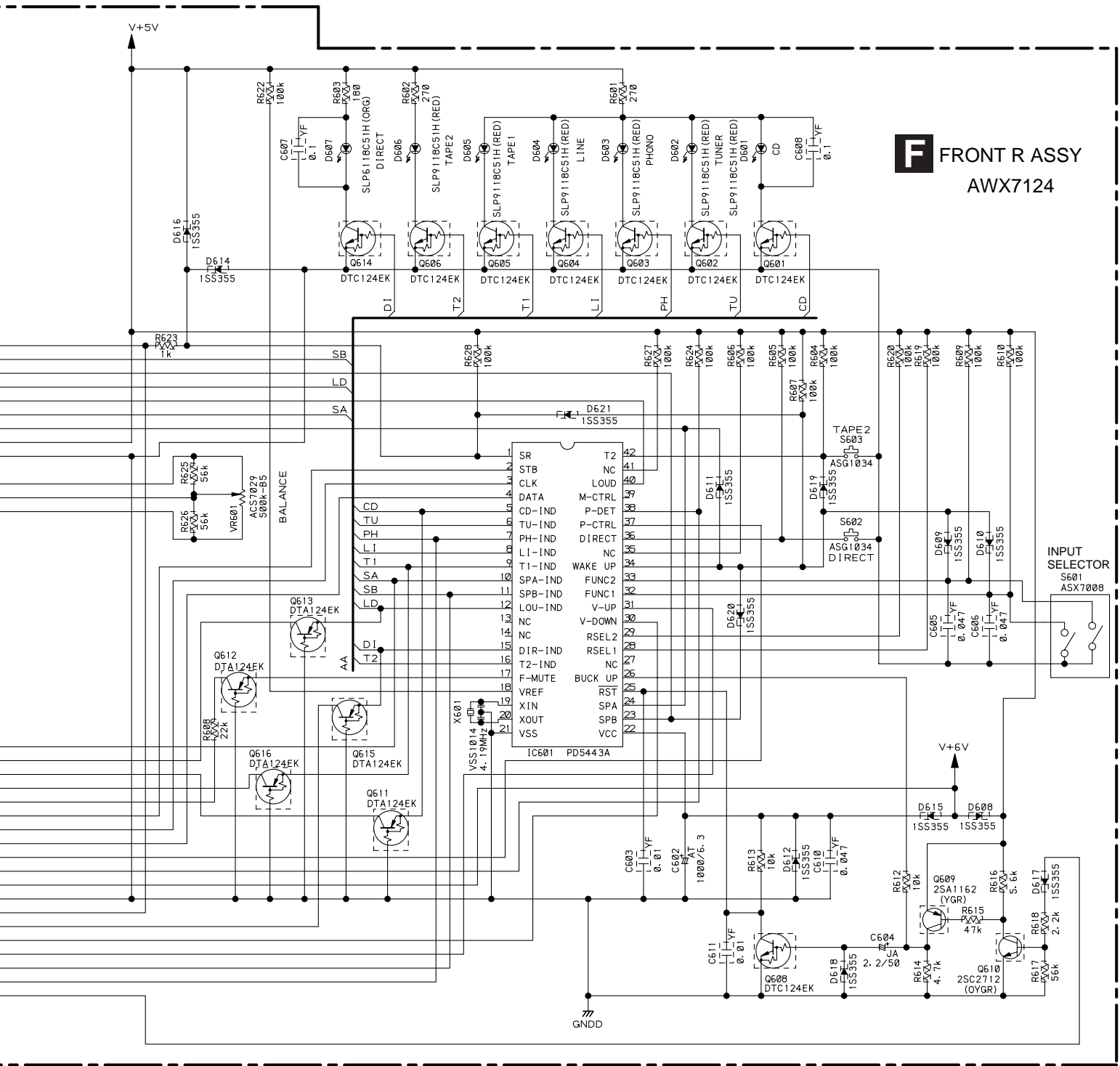

F FRONT R ASSY
AWX7124

FRONT R ASSY
S601 : INPUT SELECTOR
 CD
 TU
 PH
 LINE
 TAPE1/MD
 S602 : DIRECT
 S603 : TAPE2 MONITOR

- NOTES
1. RESISTORS
INDICATED IN Ohm 1/10W± 5% TOLERANCE UNLESS OTHERWISE NOTED
k : kOhm
 2. CAPACITORS
INDICATED IN CAPACITY (uF)/VOLTAGE (V) UNLESS OTHERWISE NOTED p:pF
INDICATED WITHOUT VOLTAGE IS 50V EXCEPT ELECTROLYTIC CAPACITOR.
AL:CEAL, AT:CEAT, JA:CEJA, TY:CFTYA, CH:CCSQCH, YF:CKSQYF
 3. THE Δ MARK FOUND ON SOME COMPONENT PARTS INDICATES THE IMPORTANCE OF THE SAFETY FACTOR. THEREFORE, WHEN REPLACING, BE SURE TO USE PARTS OF IDENTICAL DESIGNATION.



4. PCB CONNECTION DIAGRAM

4.1 VOLUME ASSY

NOTE FOR PCB DIAGRAMS :

1. Part numbers in PCB diagrams match those in the schematic diagrams.
2. A comparison between the main parts of PCB and schematic diagrams is shown below.

Symbol In PCB Diagrams	Symbol In Schematic Diagrams	Part Name
		Transistor
		Transistor with resistor
		Field effect transistor
		Resistor array
		3-terminal regulator

3. The parts mounted on this PCB include all necessary parts for several destinations.
- For further information for respective destinations, be sure to check with the schematic diagram.
4. View point of PCB diagrams.

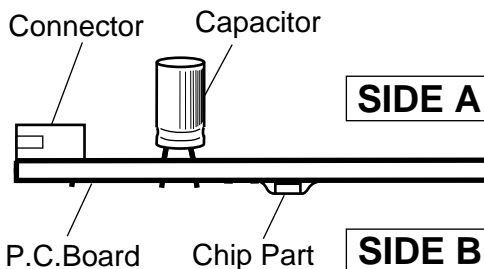

A VOLUME ASSY

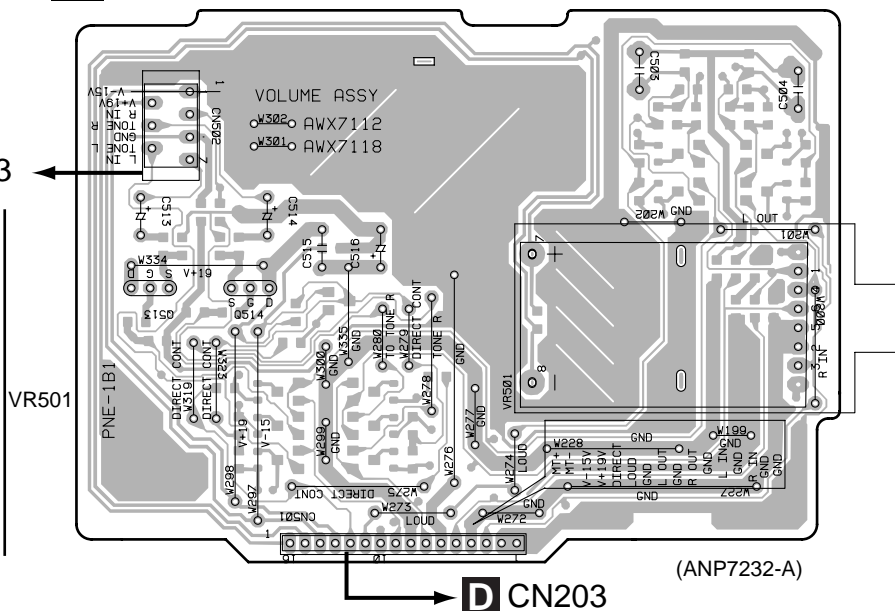

A VOLUME ASSY

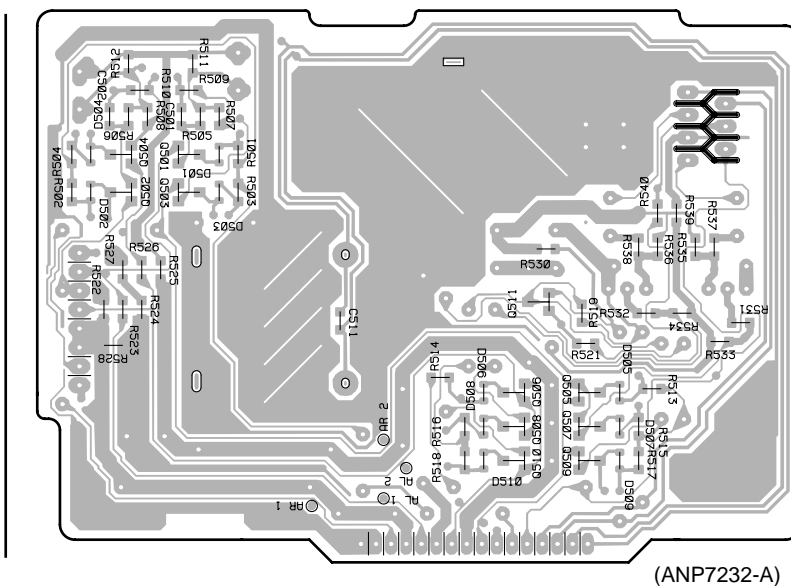

4.2 HEADPHONE AND AC PRIMARY ASSEMBLIES

B HEADPHONE ASSY

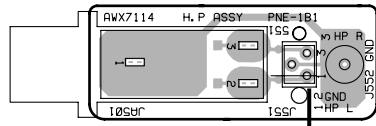

SIDE A

B HEADPHONE ASSY

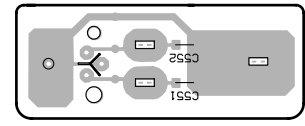

SIDE B

C AC PRIMARY ASSY

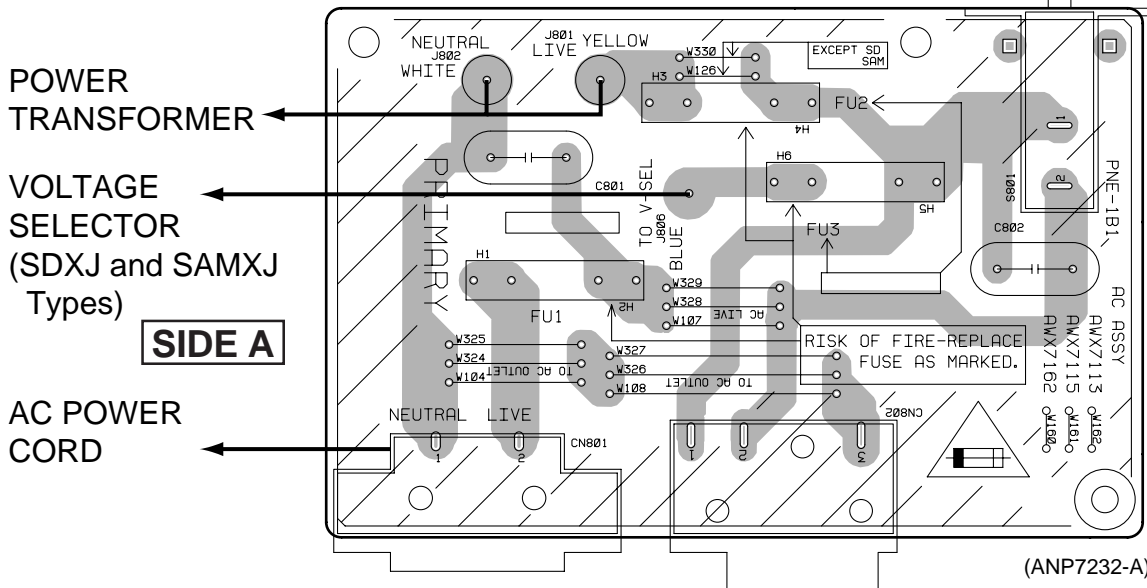

SIDE A

C AC PRIMARY ASSY

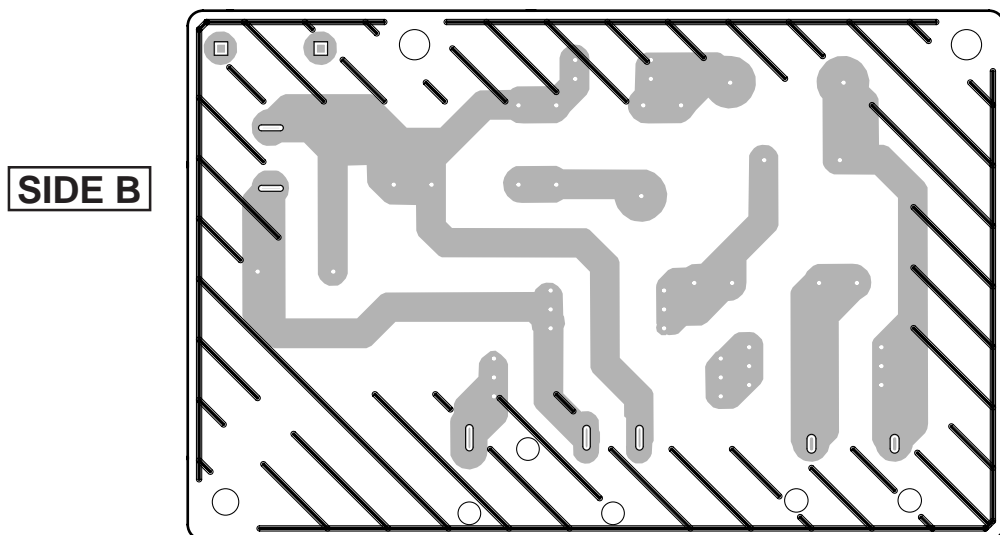

SIDE B

(ANP7232-A)

4.3 AF ASSY

D AF ASSY

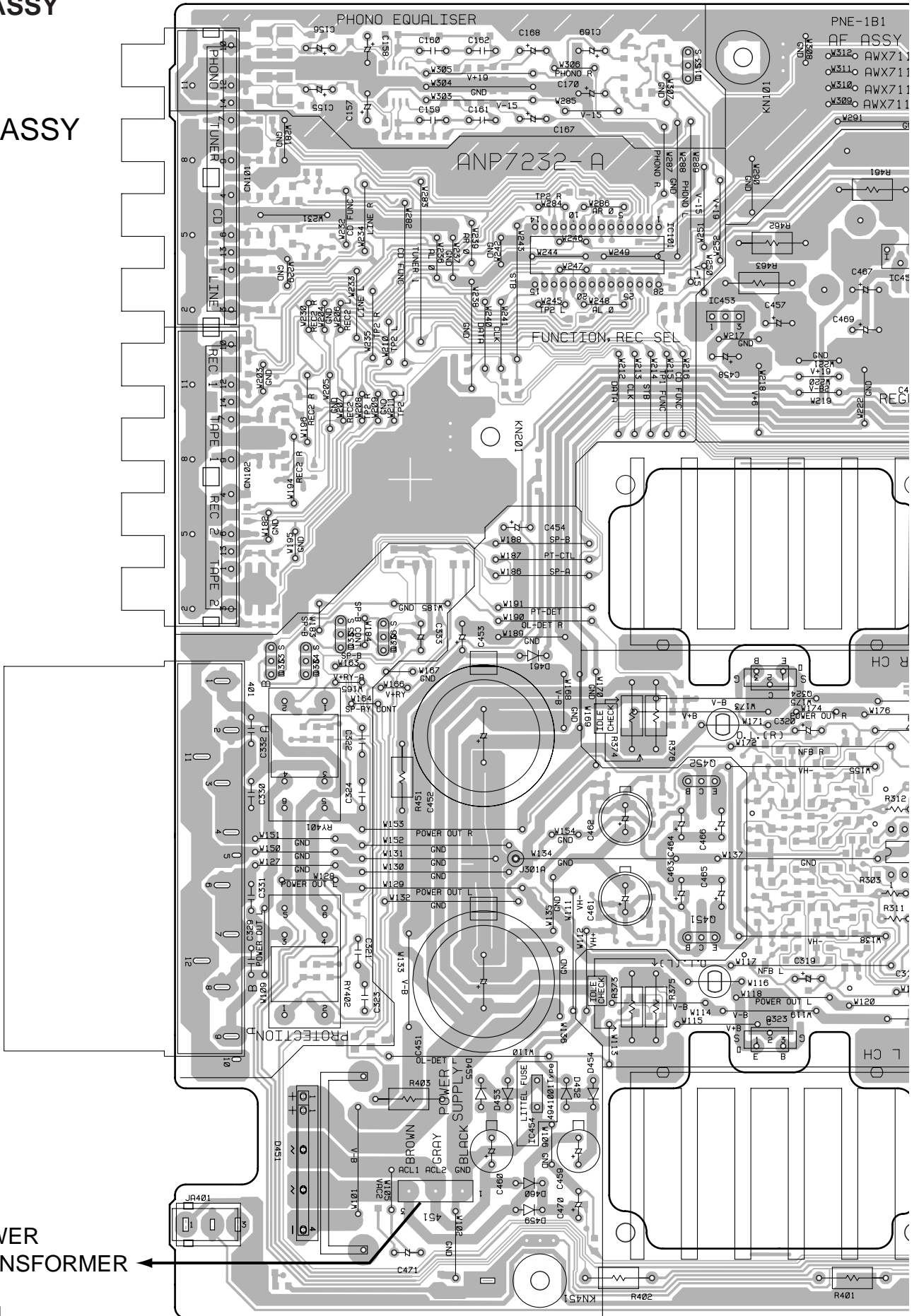

D

SIDE A

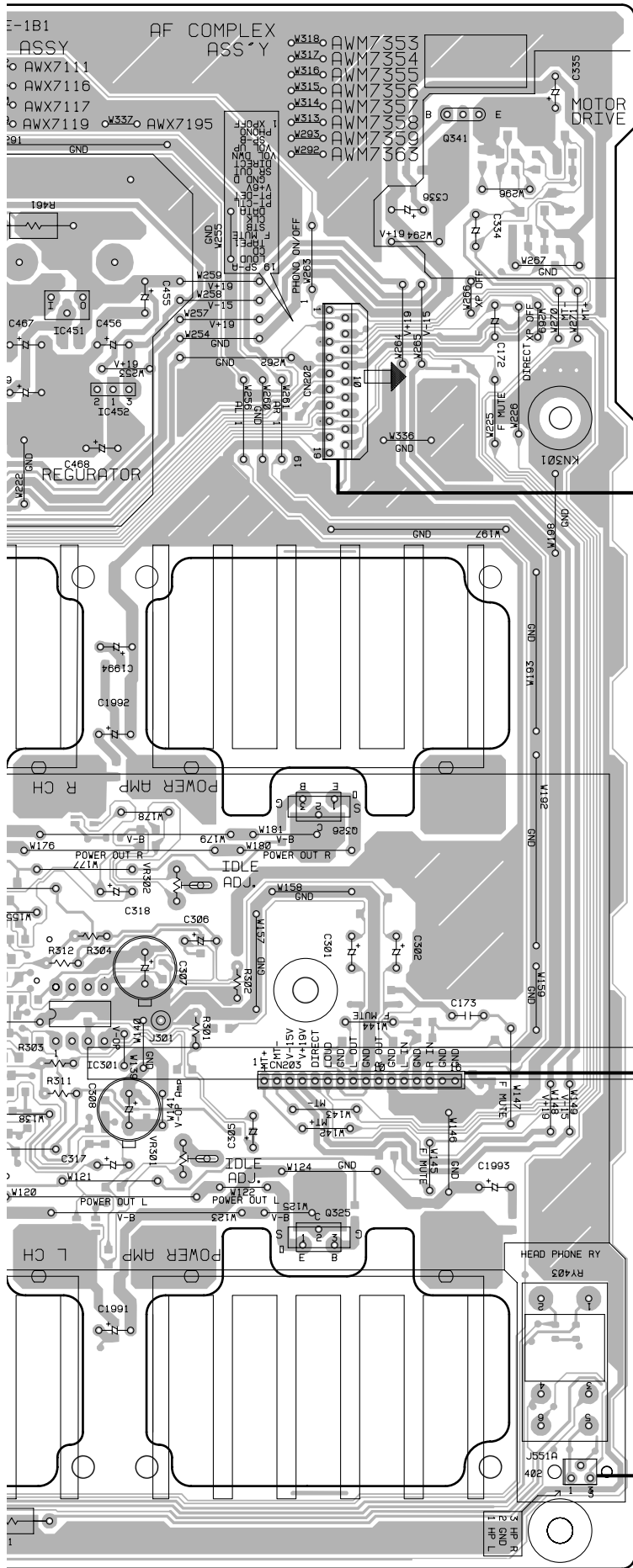

F CN601

A CN501

B J551

Q153
 Q341
 IC101
 IC451-IC453

Q333-Q336
 Q324, Q326
 VR302
 Q452

IC301
 Q451
 VR301
 Q323, Q325

IC454

A

B

C

D

(ANP7232-A)

D

SIDE B

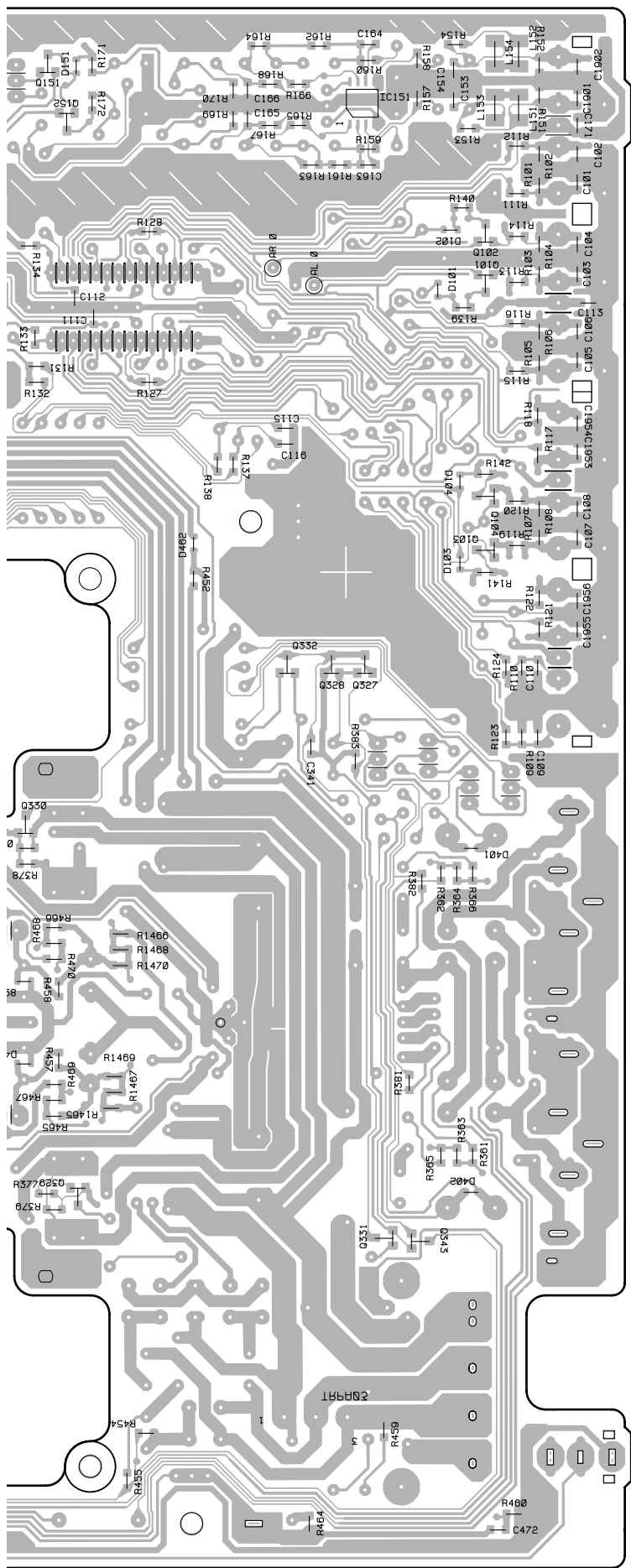

- Q151
- IC151
- Q152
- Q338, Q337
- Q340, Q339
- Q102
- Q101
- Q104
- Q103
- Q332
- Q328, Q327
- Q318, Q330
- Q322, Q320
- Q316, Q314
- Q312, Q310
- Q304, Q303
- Q311, Q309
- Q315, Q313
- Q321, Q319
- Q317, Q329
- Q331, Q343

A

B

C

D

(ANP7232-A)



4.4 FRONT L ASSY

E FRONT L ASSY

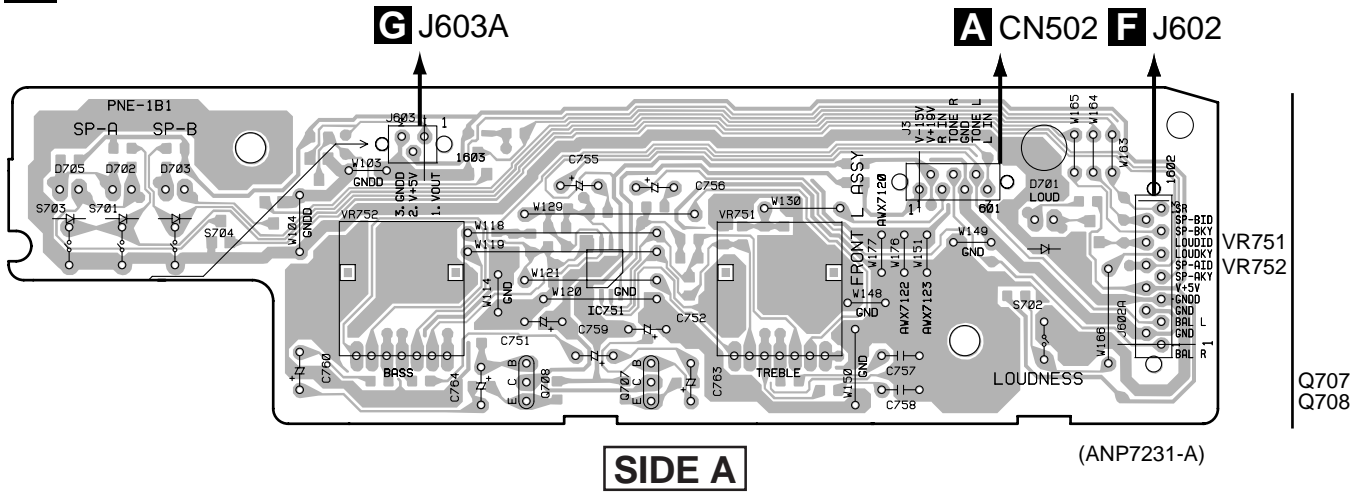

E FRONT L ASSY

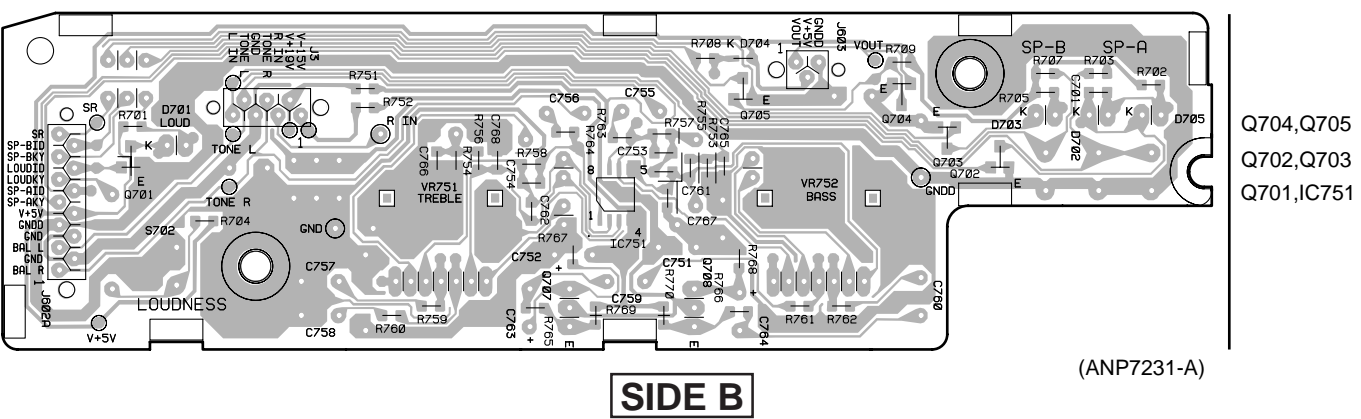

4.5 FRONT R AND OPT ASSEMBLIES

F FRONT R ASSY

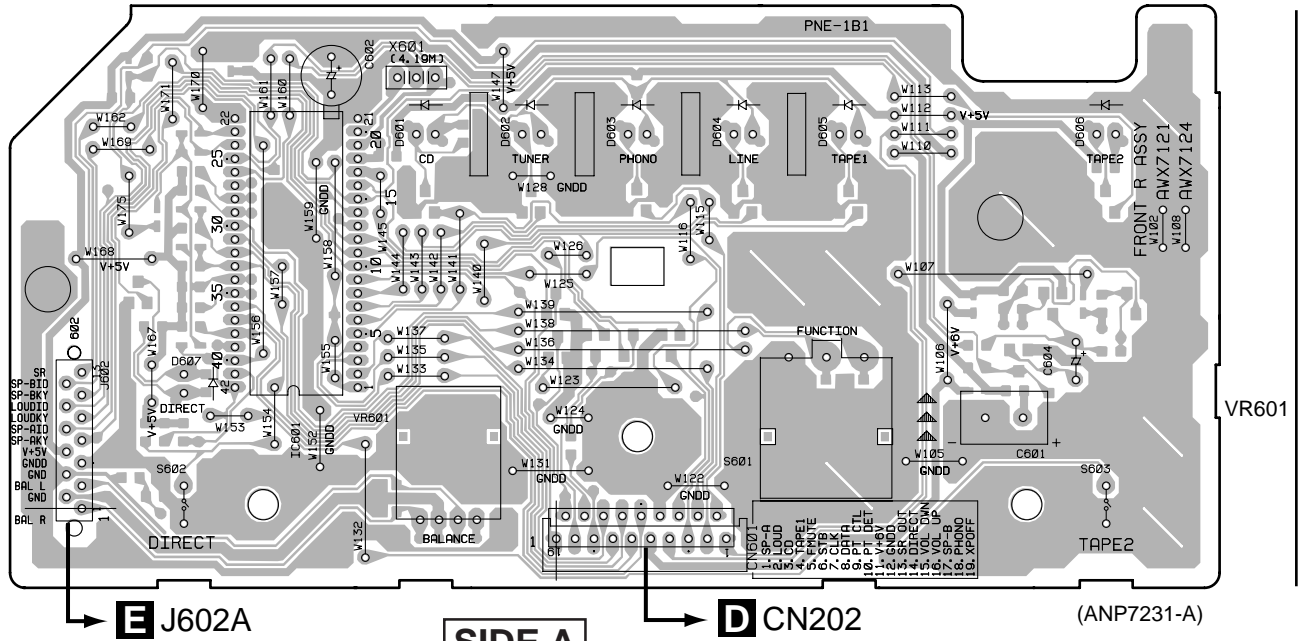

F FRONT R ASSY

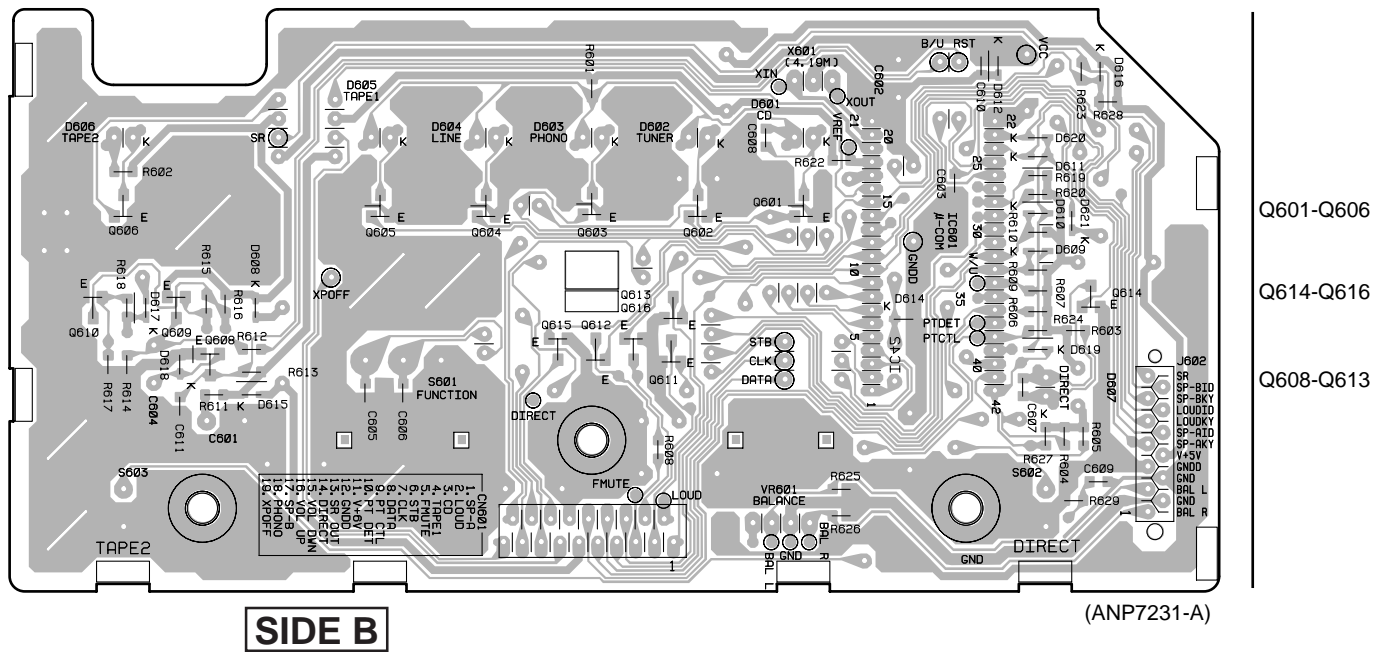

G OPT ASSY

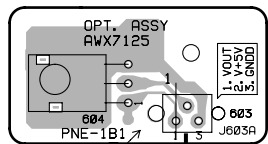

E J603

SIDE A

G OPT ASSY

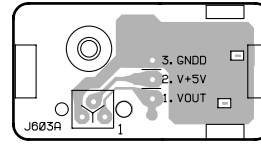

(ANP7231-A)

SIDE B

F G

5. PCB PARTS LIST

NOTES: ●Parts marked by "NSP" are generally unavailable because they are not in our Master Spare Parts List.

●The Δ mark found on some component parts indicates the importance of the safety factor of the part.

Therefore, when replacing, be sure to use parts of identical designation.

●When ordering resistors, first convert resistance values into code form as shown in the following examples.

Ex.1 When there are 2 effective digits (any digit apart from 0), such as 560 ohm and 47k ohm (tolerance is shown by J=5%, and K=10%).

560 Ω \rightarrow 56 $\times 10^1$ \rightarrow 561 RD1/4PU $\begin{matrix} \boxed{5} & \boxed{6} & \boxed{1} \\ \boxed{J} \end{matrix}$

47k Ω \rightarrow 47 $\times 10^3$ \rightarrow 473 RD1/4PU $\begin{matrix} \boxed{4} & \boxed{7} & \boxed{3} \\ \boxed{J} \end{matrix}$

0.5 Ω \rightarrow R50 RN2H $\begin{matrix} \boxed{R} & \boxed{5} & \boxed{0} \\ \boxed{K} \end{matrix}$

1 Ω \rightarrow 1R0 RS1P $\begin{matrix} \boxed{1} & \boxed{R} & \boxed{0} \\ \boxed{K} \end{matrix}$

Ex.2 When there are 3 effective digits (such as in high precision metal film resistors).

5.62k Ω \rightarrow 562 $\times 10^1$ \rightarrow 5621 RN1/4PC $\begin{matrix} \boxed{5} & \boxed{6} & \boxed{2} & \boxed{1} \\ \boxed{F} \end{matrix}$

LIST OF WHOLE PCB ASSEMBLIES

Mark	Symbol and Description	Part No.							Remarks
		A-307R				A-207R			
		MYXJ/EW	MYXJ/GR	SAMXJ	SDXJ	MYXJ/EW	MYXJ/GR	MVXJ	
NSP	AF COMPLEX ASSY	AWM7358	AWM7358	AWM7359	AWM7359	AWM7357	AWM7357	AWM7357	
	└ VOLUME ASSY	AWX7118	AWX7118	AWX7118	AWX7118	AWX7118	AWX7118	AWX7118	
NSP	└ HEADPHONE ASSY	AWX7114	AWX7114	AWX7114	AWX7114	AWX7114	AWX7114	AWX7114	
	└ AC PRIMARY ASSY	AWX7113	AWX7113	AWX7115	AWX7115	AWX7113	AWX7113	AWX7113	
	└ AF ASSY	AWX7119	AWX7119	AWX7119	AWX7119	AWX7117	AWX7117	AWX7117	
NSP	CONTROL ASSY	AWG7013	AWG7013	AWG7013	AWG7013	AWG7013	AWG7013	AWG7013	
	└ FRONT L ASSY	AWX7123	AWX7123	AWX7123	AWX7123	AWX7123	AWX7123	AWX7123	
	└ FRONT R ASSY	AWX7124	AWX7124	AWX7124	AWX7124	AWX7124	AWX7124	AWX7124	
	└ OPT ASSY	AWX7125	AWX7125	AWX7125	AWX7125	AWX7125	AWX7125	AWX7125	

Mark No. Description Part No.

A VOLUME ASSY

SEMICONDUCTORS

Q513,Q514 2SK246
 Q501-Q510 2SK303
 Q511 DTC124EK
 D505,D506,D509,D510 1SS352
 D501-D504,D507,D508 1SS355

CAPACITORS

C501,C502 CCSQCH271J50
 C513,C514 CEAT100M50
 C516 CEAT330M25
 C503,C504 CFTYA473J50
 Δ C515 CKCYF103Z50

 C511 CKSQYF473Z50

RESISTORS

Δ R530 RS1/10S100J
 VR501 ACX7021
 Other Resistors RS1/10S□□□J

OTHERS

CN501 16P SOCKET KP200TA16L
 CN502 CONNECTOR 7P KPE7
 PCB BINDER VEF1040

Mark No. Description Part No.

B HEADPHONE ASSY

CAPACITORS

C551,C552 CKSQYB392K50

OTHERS

3P CABLE HOLDER 51063-0305
 J552 CORD WITH PLUG DE005WE0
 JA501 HEADPHONE JACK RKN1002
 J551 JUMPER WIRE D15A03-150-2651

C AC PRIMARY ASSY

(1) CONTRAST TABLE

AWX7113 and AWX7115 are constructed the same except for the following :

Mark	Symbol and Description	Part No.		Remarks
		AWX7113	AWX7115	
Δ	H3-H6 FUSE CLIP	Not used	AKR7001	
	3P OUTLET	Not used	AKP1053	

(2) PARTS LIST FOR AWX7113

SWITCH

Δ S801 ASG1035

CAPACITORS

Δ C801,C802 (0.01 μ F/AC250V) ACG7020

OTHERS

Δ CN801 AC INLET AKP7005
 H1,H2 FUSE CLIP AKR7001

Mark No. Description Part No.

D AF ASSY

(1) CONTRAST TABLE

AWX7119 and AWX7117 are constructed the same except for the following :

Mark	Symbol and Description	Part No.		Remarks
		AWX7119	AWX7117	
	C451 (10000µF/42V)	ACH7048	Not used	
	C451 (6800µF/42V)	Not used	ACH7080	
	C452 (10000µF/42V)	ACH7049	Not used	
	C452 (6800µF/42V)	Not used	ACH7081	

(2) PARTS LIST FOR AWX7119

SEMICONDUCTORS

△	IC454 (1A)	AEK7009	
△	IC453	BA178M06T	
△	IC451	BA178M15T	
△	IC452	NJM79M15FA	
	IC101	TC9163AN	
	IC301	UPC4570C	
	IC151	UPC4570G2	
	Q311, Q312, Q329, Q330	2SA1162	
	Q337, Q338	2SA1162	
	Q313, Q314, Q321, Q322	2SA1255	
△	Q452	2SA1837	
	Q309, Q310, Q327, Q328	2SC2712	
	Q339, Q340	2SC2712	
	Q315, Q316, Q319, Q320	2SC3138	
	Q303, Q304	2SC3326	
△	Q451	2SC4793	
	Q341	2SC5174P	
	Q101-Q104	2SK303	
	Q151	DTA124EK	
	Q152	DTC124EK	
	Q153	DTC124ES	
	Q331, Q332, Q343	DTC143EK	
	Q333-Q336	DTC143ES	
	Q317, Q318	IMX1	
△	Q323, Q324	IRF530	
△	Q325, Q326	IRF9530	
	D101-D104, D151, D301-D310	1SS355	
	D401-D404	1SS355	
△	D451	D5SBA20	
△	D452-D455, D459, D460	S5566G(TPB2)	
	D461	S5566G(TPB2)	
	D311, D312	UDZ15B	
	D457, D458	UDZ36B	
	D456	UDZ4.7B	
	D341	UDZS5.1B	
	D462	UDZS5.6B	

COILS

L151-L154	LCTA221J3225
-----------	--------------

RELAYS

RY401-RY403	ASR7014
-------------	---------

Mark No. Description Part No.

CAPACITORS

	C451 (10000µF/42V)	ACH7048
	C452 (10000µF/42V)	ACH7049
△	C329, C331	CCCSL101K2H
	C313-C316, C337-C340	CCSQCH121J50
△	C153, C154	CCSQCH151J50
	C303, C304	CCSQCH221J50
△	C163, C164	CCSQCH390J50
△	C101-C110	CCSQCH470J50
	C334	CEANP100M16
	C471	CEANP1R0M2A
	C172	CEANP1R0M50
	C333	CEANP470M10
	C155, C156, C167, C168	CEAT100M50
	C317-C320, C335, C336	CEAT100M50
	C453-C458, C465, C466, C469	CEAT100M50
	C461, C462	CEAT101M2A
	C467, C468	CEAT1R0M50
	C470	CEAT3R3M50
	C169, C170	CEAT470M25
	C459, C460, C463, C464	CEAT470M50
	C157, C158	CEAT471M6R3
	C301, C302, C305, C306	CEBA100M50
	C307, C308	CEBA221M25
	C321-C324	CFTYA224J50
	C173	CFTYA564J50
△	C330, C332	CKCYB331K2H
	C165, C166	CKSQYB222K50
	C111-C113, C171, C341	CKSQYF473Z50
△	C472	CKSQYF473Z50
	C159, C160	CQMA243J50
	C161, C162	CQMA823J50
	R311, R312	RDR1/4VM152J
	R301, R302	RDR1/4VM240J
	R303, R304	RDR1/4VM561J
△	R143	RS1/10S100J
△	R133, R134, R171, R172	RS1/10S101J
△	R351-R354, R452	RS1/10S101J
△	R317, R318, R331, R332	RS1/10S122J
△	R357-R360	RS1/10S151J
△	R377, R378, R453	RS1/10S153J
△	R465-R470	RS1/10S161J
△	R361-R366	RS1/10S1R5J
△	R339-R346	RS1/10S221J
△	R454	RS1/10S273J
△	R460	RS1/10S2R2J
△	R355, R356	RS1/10S432J
△	R459	RS1/10S470J
△	R464	RS1/10S4R7J
△	R379, R380	RS1/10S682J
△	R451	RS1LMF270J
△	R401, R402	RS1LMF331J
△	R461-R463	RS1LMF390J
△	R403	RS1LMF821J
△	R373-R376	RS1LMFR22J
	VR301, VR302 (2.2kΩ)	VCP1123
	Other Resistors	RS1/10S□□□□J

A-307R, A-207R

Mark	No.	Description	Part No.
OTHERS			
		3P CABLE HOLDER SCREW	51063-0305 ABA1007
		SCREW	ABA1052
CN101,CN102		8P PIN JACK	AKB7023
		8P SPEAKER TERMINAL	AKE1011
		HEAT SINK M	ANH-813
		HEAT SINK B	ANH1021
CN202		FFC CONNECTOR 19P	HLEM19S-1
CN203		16P PLUG	KM200TA16
JA401		REMOTE CONTROL JACK	RKN1004
		PCB BINDER	VEF1040
KN101,KN201,KN301,KN451		EARTH METAL FITTING	VNF1084

E FRONT L ASSY

SEMICONDUCTORS

IC751	UPC4570G2
Q707,Q708	2SC1845
Q705	2SC2712
Q701-Q704	DTC124EK
D704	1SS355
D701,D703,D705	SLP9118C51H

SWITCHES

S702-S704	ASG1034
-----------	---------

CAPACITORS

C753,C754,C761,C762	CCSQCH101J50
C767,C768	CCSQCH221J50
C751,C752,C755,C756	CEAL100M50
C763,C764	CEALR10M50
C759,C760	CEALR47M50
C757,C758	CFTYA153J50
C701	CKSQYF104Z25

RESISTORS

△ R751,R752	RS1/10S101J
VR751,VR752 (30kΩ)	ACS7028
Other Resistors	RS1/10S□□□J

OTHERS

	3P CABLE HOLDER	51063-0305
	7P CABLE HOLDER	51063-0705
	13P CABLE HOLDER	51063-1305
J603	JUMPER WIRE	D15A03-100-2651
J3	JUMPER WIRE	D15A07-200-2651

F FRONT R ASSY

SEMICONDUCTORS

IC601	PD5443A
Q609	2SA1162
Q610	2SC2712
Q611-Q613,Q615,Q616	DTA124EK
Q601-Q606,Q608,Q614	DTC124EK

Mark	No.	Description	Part No.
		D608-D612,D614-D621	1SS355
		D607	SLP6118C51H
		D601-D606	SLP9118C51H

SWITCHES

S602,S603	ASG1034
S601	ASX7008

CAPACITORS

C602	CEAT102M6R3
C604	CEJA2R2M50
C603,C611	CKSQYF103Z50
C607,C608	CKSQYF104Z25
C605,C606,C610	CKSQYF473Z50

RESISTORS

VR601 (500kΩ)	ACS7029
Other Resistors	RS1/10S□□□J

OTHERS

X601	CERAMIC RESONATOR (4.19MHz)	VSS1014
	13P CABLE HOLDER	51063-1305
CN601	19P FFC CONNECTOR	9607S-19F
J602	JUMPER WIRE	D15A13-125-2651

G OPT ASSY

OTHERS

3P CABLE HOLDER	51063-0305
REMOTE RECEIVER UNIT	GP1U27X

6. ADJUSTMENT

6.1 IDLE CURRENT ADJUSTMENT

- CAUTION : Heatsinks' (Q323–Q326) DC level is equal to +B or -B.
Don't touch them or you will be electric shocked.

1. Connect the measuring instrument as shown in Fig.6-1. (R373 or R374)
2. Turn the POWER switch to ON.
3. Adjust VR301 (VR302) so that the voltage between both sides of R373 (R374) becomes $10\text{mV} \pm 1\text{mV}$.
4. Ages for 5 minutes.
5. Adjust VR301 (VR302) so that the voltage between both sides of R373 (R374) becomes $11\text{mV} \pm 1\text{mV}$.

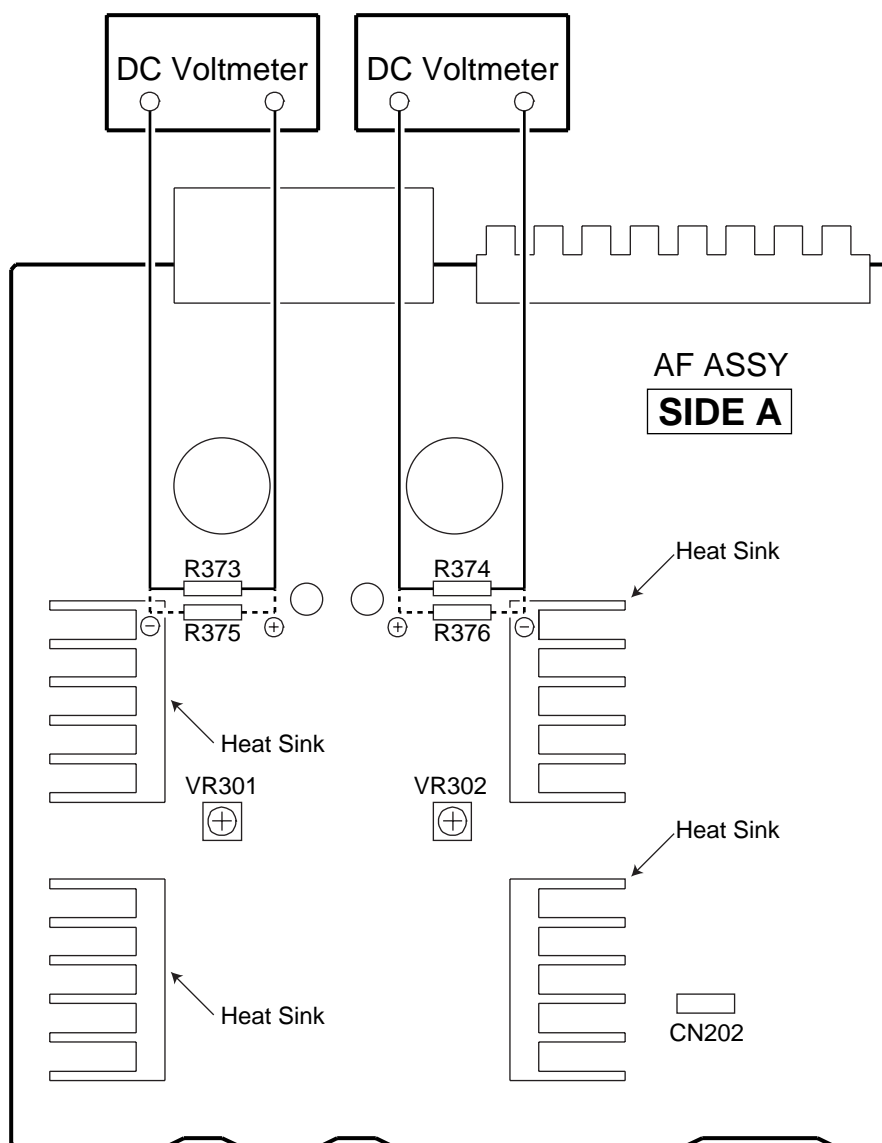

Fig.6-1 Adjustment Method

7. GENERAL INFORMATION

7.1 IC

■ PD5443A (FRONT R ASSY : IC601)

● REMOTE CONTROL AMP MICROCOMPUTER

● Pin Assignment (Top view)

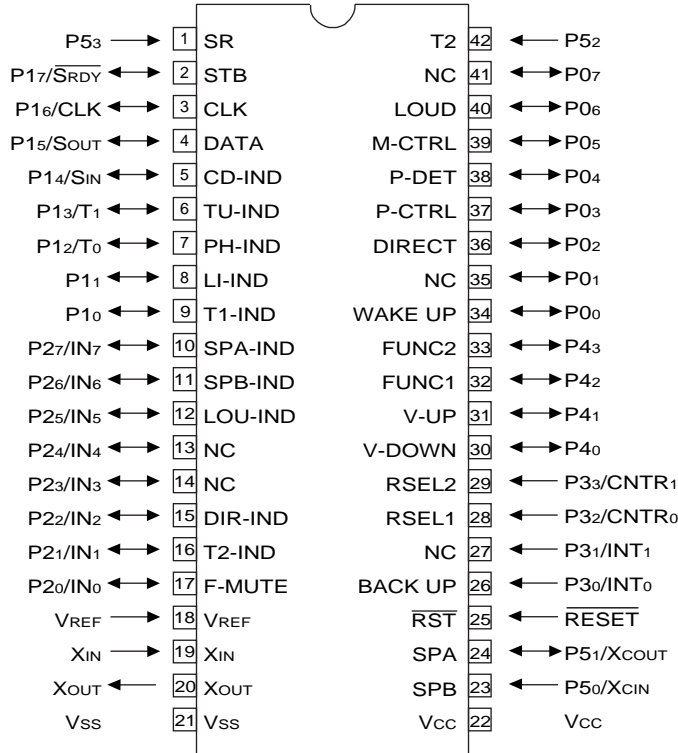

- The information shown in the list is basic information and may not correspond exactly to that shown in the schematic diagrams.

● Pin Function

No.	Pin name	I/O	Function
1	P5 ₃	I	Remote control signal input pin.
2	P17/ $\overline{\text{SRDY}}$	O	STB for TC9163N.
3	P16/CLK	O	CLOCK for TC9163N.
4	P15/SOUT	O	DATA for TC9163N.
5	P14/SIN	O	CD INDICATOR.
6	P13/T ₁	O	TUNER INDICATOR.
7	P12/T ₀	O	PHONO INDICATOR.
8	P1 ₁	O	LINE INDICATOR.
9	P1 ₀	O	TAPE1 INDICATOR.
10	P27/IN ₇	O	SPEAKER-A INDICATOR.
11	P26/IN ₆	O	SPEAKER-B INDICATOR.
12	P25/IN ₅	O	LOUDNESS INDICATOR.
13	P24/IN ₄	O	Not used.
14	P23/IN ₃	O	Not used.
15	P22/IN ₂	O	DIRECT INDICATOR.
16	P21/IN ₁	O	TAPE2 INDICATOR.
17	P20/IN ₀	O	FUNCTION switch MUTE.
18	V _{REF}	I	Pulls up to 5V.
19	X _{IN}	I	4.19MHz .
20	X _{OUT}	O	Ceramic vibrating and connecting terminal.
21	V _{SS}	-	Digital GND.
22	V _{CC}	-	Power supply +5V.
23	P50/X _{CIN}	I	SPEAKER-B KEY input.

No.	Pin name	I/O	Function
24	P51/X _{COUT}	I	SPEAKER-A KEY input.
25	RESET	I	Reset pin.
26	P30/INT ₀	I	BACK UP detection pin. interrupt specification.
27	P31/INT ₁	I	Not used.
28	P32/CNTR ₀	I	REC selector input 1.
29	P33/CNTR ₁	I	REC selector input 2. interrupt specification.
30	P4 ₀	O	Volume DOWN data output.
31	P4 ₁	O	Volume UP data output.
32	P4 ₂	I	FUNCTION selector input 1.
33	P4 ₃	I	FUNCTION selector input 2.
34	P0 ₀	I	WAKE UP input. Key on wake up specification.
35	P0 ₁	O	Not used.
36	P0 ₂	I	DIRECT KEY input. Key on wake up specification.
37	P0 ₃	O	Protection control pin.
38	P0 ₄	I	Output error detection pin
39	P0 ₅	O	MUTING control pin.
40	P0 ₆	I	LOUDNESS KEY input. Key on wake up specification.
41	P0 ₇	O	Not used.
42	P5 ₂	I	TAPE2 KEY input.

7.2 DISASSEMBLY

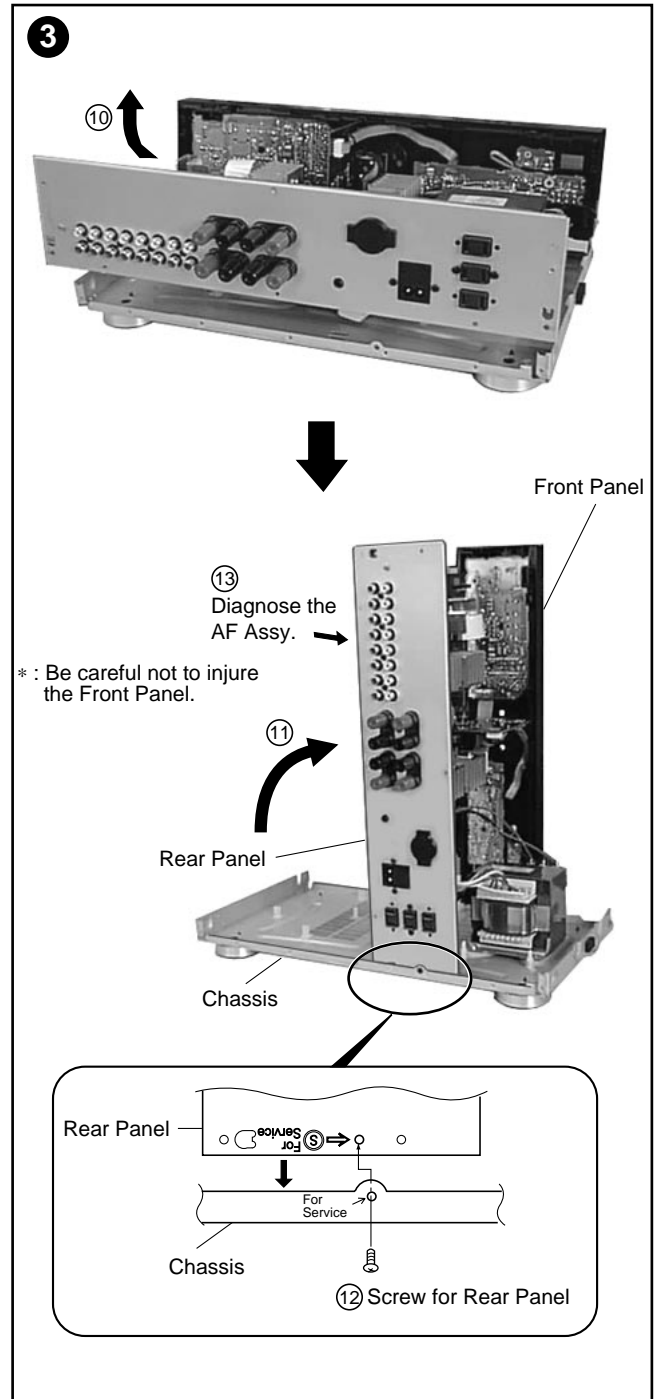
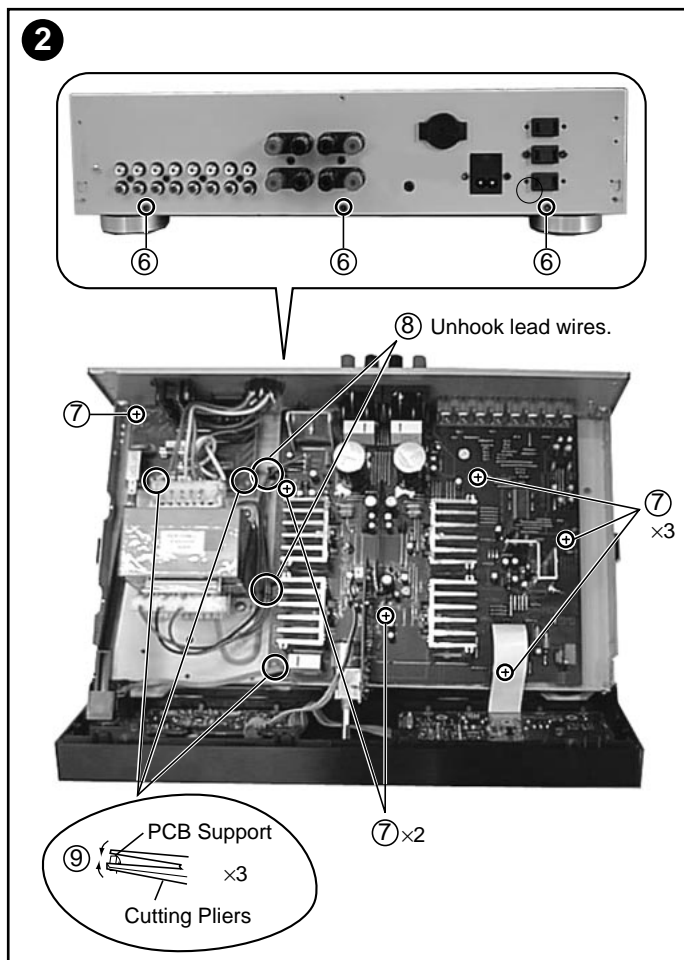
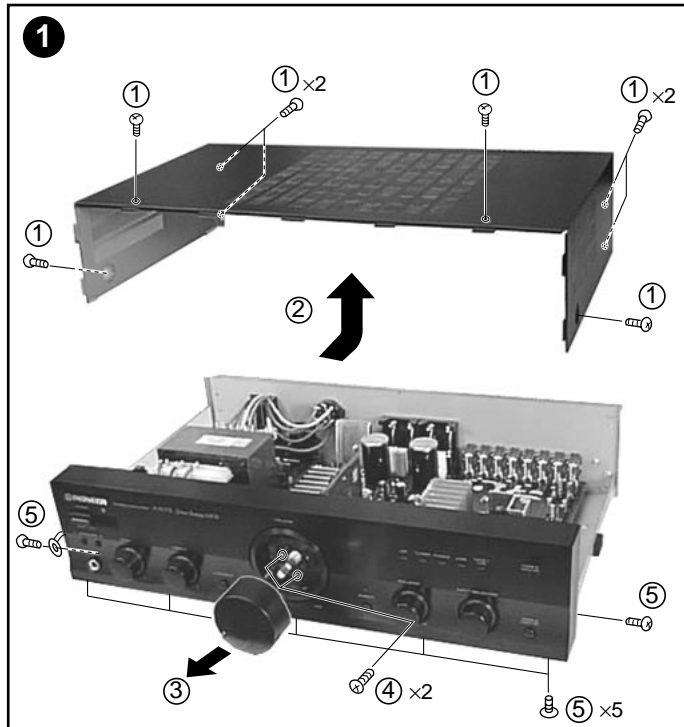

7.3 BLOCK DIAGRAM

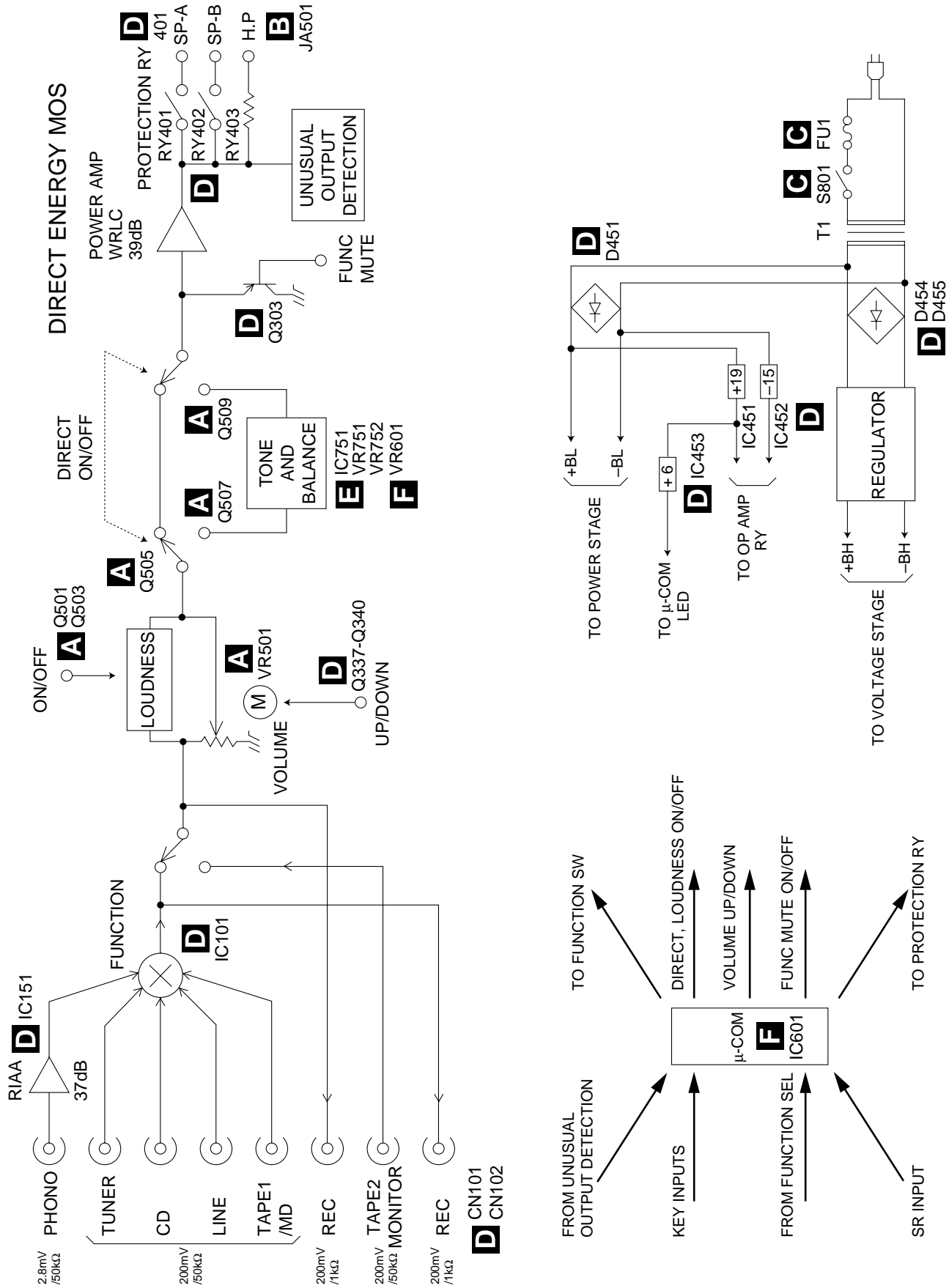

8. PANEL FACILITIES AND SPECIFICATIONS

8.1 PANEL FACILITIES

■ REAR PANEL

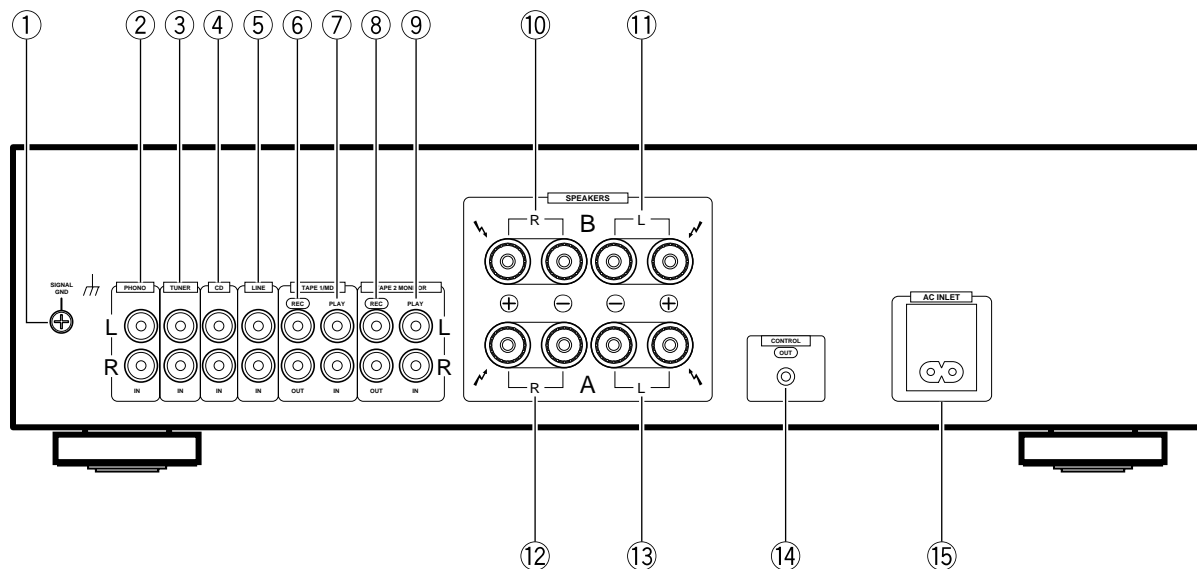

- ① GND (Turntable ground) terminal
- ② PHONO terminals
- ③ TUNER terminals
- ④ CD terminals
- ⑤ LINE terminals
- ⑥ TAPE 1/MD REC (OUT) terminals
- ⑦ TAPE 1/MD PLAY (IN) terminals
- ⑧ TAPE 2 MONITOR REC (OUT) terminals
- ⑨ TAPE 2 MONITOR PLAY (IN) terminals
- ⑩ SPEAKERS B terminals (Right channel)

- ⑪ SPEAKERS B terminals (Left channel)
- ⑫ SPEAKERS A terminals (Right channel)
- ⑬ SPEAKERS A terminals (Left channel)

⑭ CONTROL OUT jack

This jack is for output of control signals when operating other components bearing the  mark with the attached remote control unit.

⑮ AC INLET jack

Connect power cord to here and an AC wall socket, or the AC outlet of an audio timer.

If you are going to be away from home for a long period of time, disconnect the unit from the wall socket.

NOTES:

- If you use an other power cord than provided, we cannot assume the liabilities in what may occur as a result of it.
- (The provided power cord has a current capacity of 2.5 A.)

FRONT PANEL

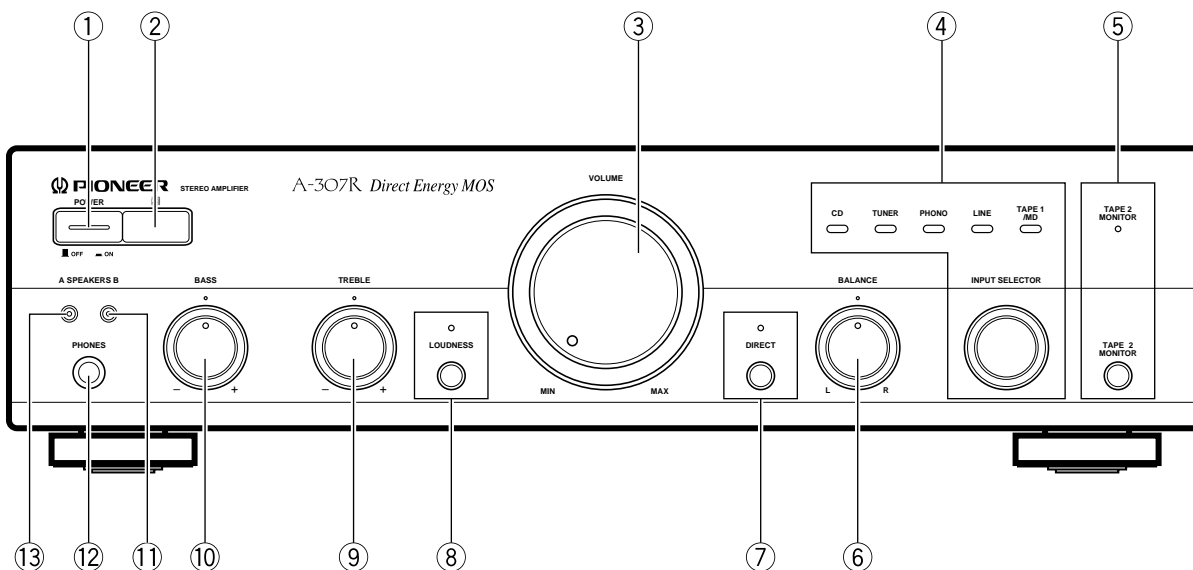

The illustration shows the A-307R.

① POWER (■ OFF/■ ON) switch

Press to turn power to the unit ON and OFF. This unit cannot be turned ON and OFF using the remote control unit.

② REMOTE CONTROL SENSOR window

③ VOLUME control

Use to adjust the volume level.

④ INPUT SELECTOR knob/indicators

Turn the knob clockwise or counterclockwise so that the indicator lights for your desired input source. Turning the knob clockwise causes the lit indicator to right. Turning counterclockwise causes it to left.

- CD** : For compact disc playback with a CD player.
- TUNER** : For AM or FM broadcast reception with a tuner.
- PHONO** : For record playback with a turntable.
- LINE** : Set to this position when listening to the program from a component connected to the LINE terminals.
- TAPE 1/MD** : For playback with a cassette deck or MD recorder connected to TAPE 1/MD terminals.

⑤ TAPE 2 MONITOR button/indicator

Use when there is an adaptor component (graphic equalizer, etc.) or cassette deck connected to the TAPE 2 MONITOR terminals.

On : Indicator lights when using the adaptor component or listening to the cassette deck.

Off : Indicator goes off when not in use.

NOTES:

- When no connections are made to the TAPE 2 MONITOR terminals, or when they are not in use, be sure to set this switch to the off position. (No sound will be heard if it is set to the on position.)
- When the TAPE 2 MONITOR indicator is on and the INPUT SELECTOR knob is not set to TAPE 1/MD, the signals which are input through TAPE 2 MONITOR are then output at TAPE 1/MD REC OUT.

⑥ BALANCE control

Should normally be left in the center position. Adjust balance if the sound is louder from one of the speakers. If the right side is louder, turn toward the L (left) position and if the left side is louder, turn toward the R (right) position.

NOTE:

This control does not operate when the DIRECT button is in the on position.

⑦ DIRECT button/indicator

Use this button when you do not wish to pass the output from input terminal equipment through the various frequency adjusting circuits (BASS, TREBLE, BALANCE, LOUDNESS).

On : The indicator lights: The signals passing through the input terminals are reproduced without passing through the various frequency adjusting circuits. This results in flat, pure sound which is a more faithful reproduction of the input source.

Off : The indicator goes off: The signal passes through the various frequency adjusting circuits.

⑧ LOUDNESS button/indicator

Use when listening at low volume levels.

On : The indicator lights: Boosts low and high frequencies to give added punch to playback even at a low volume level.

Off : The indicator goes off: Should normally be left in this position.

NOTE:

This button does not operate when the DIRECT button is in the on position.

⑨ TREBLE tone control

Use to adjust the high-frequency tone. The center position is the flat (normal) position. When turned to the right, high-frequency tones are emphasized; when turned to the left, high-frequency tones are de-emphasized.

NOTE:

This control does not operate when the DIRECT button is in the on position.

⑩ BASS tone control

Use to adjust the low-frequency tone. The center position is the flat (normal) position. When turned to the right, low-frequency tones are emphasized; when turned to the left, low-frequency tones are de-emphasized.

NOTE:

This control does not operate when the DIRECT button is in the on position.

⑪ SPEAKERS B (ON/OFF) button/indicator

Use this button to listen to the speaker system connected to SPEAKERS B terminals.

ON : The indicator lights. Sound is heard from the speaker system.

OFF : The indicator goes off. No sound is heard from the speaker system. Set to this position when listening with headphones.

⑫ PHONES jack

When using headphones, insert the plug into this jack.

NOTE:

The speakers continue to output sound even when headphones are plugged into this jack.

To mute the sound from the speakers, press the SPEAKERS button to OFF.

⑬ SPEAKERS A (ON/OFF) button/indicator

Use this button to listen to the speaker system connected to SPEAKERS A terminals.

ON : The indicator lights. Sound is heard from the speaker system.

OFF : The indicator goes off. No sound is heard from the speaker system. Set to this position when listening with headphones.

■ REMOTE CONTROL

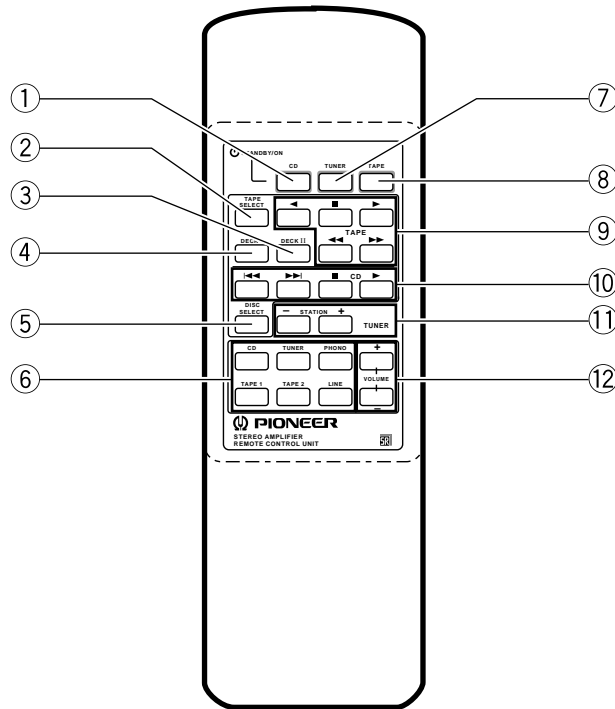

① **CD POWER button**

Switches CD player power STANDBY/ON.

② **TAPE SELECT button**

Selects the cassette No. (1 to 6) for multi-cassette changer.

③ **DECK II button**

To operate Deck II, press this button before pressing the operating buttons. Also, when using a single deck, press this button before pressing the operating buttons.

④ **DECK I button**

To operate Deck I, press this button before pressing the operating buttons.

⑤ **DISC SELECT button**

Press this to select discs on a multi or twin tray compact disc player.

⑥ **Input selector button**

Use to select the playback source.

CD : For compact disc playback with a CD player.

TUNER : For AM or FM broadcast reception with a tuner.

PHONO : For record playback with a turntable.

TAPE 1 : For playback with a cassette deck or MD deck recorder connected to TAPE 1/MD terminals.

TAPE 2 : For playback with a cassette deck or adaptor connected to TAPE 2 MONITOR terminals.

LINE : For playback with a component connected to the LINE terminal.

⑦ **TUNER POWER button**

Switches TUNER power STANDBY/ON.

⑧ **TAPE POWER button**

Switches the cassette deck power STANDBY/ON. (Can not turn ON/OFF some cassette decks.)

⑨ **TAPE operation buttons**

◀, ▶ : Playback in the direction of the arrows.

■ : Stop

◀◀, ▶▶ : Tape fast forward/reverse.

⑩ **CD player operation buttons**

◀◀ : Returns you to the start of the current track. (Track search)

▶▶ : Takes you to the start of the next track. (Track search)

■ : Stop

▶ : Play

⑪ **STATION + (up), - (down) buttons**

Calls each station number in sequence.

⑫ **VOLUME + (up), - (down) buttons**

+ Increases the volume.

- Decreases the volume.

NOTE:

When the accessory remote control unit is used to operate other Pioneer components with the  mark, it cannot be used to operate functions which do not correspond to the functions listed on the remote control unit.

8.2 SPECIFICATIONS

Amplifier Section

Continuous power output

(both channels driven at 20 Hz to 20 kHz)**

[A-307R]	
T.H.D. 0.1 %, 8 Ω	45 W + 45 W*
T.H.D. 0.15 %, 4 Ω	65 W + 65 W*
[A-207R]	
T.H.D. 0.1 %, 8 Ω	35 W + 35 W*
T.H.D. 0.15 %, 4 Ω	45 W + 45 W*

DIN Continuous power output

(both channels driven at 1 kHz)

[A-307R]	
T.H.D. 1.0 %, 8 Ω	55 W + 55 W
T.H.D. 1.0 %, 4 Ω	80 W + 80 W
[A-207R]	
T.H.D. 1.0 %, 8 Ω	45 W + 45 W
T.H.D. 1.0 %, 4 Ω	60 W + 60 W

Total harmonic distortion**

[A-307R]	
20 Hz to 20 kHz, 22.5 W, 8 Ω	0.08 %*
[A-207R]	
20 Hz to 20 kHz, 17.5 W, 8 Ω	0.08 %*

- **Power output specification is for when power supply is 230V.**

Input sensitivity/impedance

PHONO (MM)	2.8 mV/50 k Ω
CD, TUNER, LINE, TAPE 1/MD, TAPE 2 MONITOR	
.....	200 mV/50 k Ω

PHONO (MM) overload level

1 kHz, T.H.D. 0.1 %	150 mV
---------------------------	--------

Output level/impedance

TAPE 1 REC, TAPE 2 MONITOR REC	200 mV/1 k Ω
--------------------------------------	---------------------

Frequency response

PHONO (MM)	20 Hz to 20 kHz, ± 0.5 dB
CD, TUNER, LINE, TAPE 1/MD, TAPE 2 MONITOR	
.....	5 Hz to 100 kHz, $^{+0}_{-3}$ dB*

Tone control

BASS	± 8 dB (100 Hz)
TREBLE	± 8 dB (10 kHz)

Loudness contour (volume control set at -30 dB position)

.....	+6 dB (100 Hz)/+4 dB (10 kHz)
-------	-------------------------------

Signal-to-Noise ratio (IHF short circuit, A network)

PHONO (MM, 5 mV input)	85 dB*
CD, TUNER, LINE, TAPE 1/MD, TAPE 2 MONITOR	
.....	106 dB*

Signal-to-Noise ratio (DIN, continuous power/50 mW)

PHONO (MM)	71 dB/67 dB*
CD, TUNER, LINE, TAPE 1/MD, TAPE 2 MONITOR	
.....	91 dB/71 dB*

Power Supply/Miscellaneous

Power requirements AC 220 – 230 V, 50/60 Hz

Power consumption

[A-307R]	140 W
[A-207R]	130 W
Dimensions (including knobs and other protruding parts)	
.....	420 (W) x 114 (H) x 307 (D) mm
Weight (without package)	
[A-307R]	5.9 kg
[A-207R]	4.7 kg

Accessories

Remote control unit	1
Batteries (AA/R6P)	2
Power cord (Rated current 2.5 A)	1
Operating instructions	1
Warranty card	1

NOTE:

Specifications and design are subject to possible modifications without notice, due to improvements.

* Measured with DIRECT button set to on.

** Measured by Audio Spectrum Analyzer.