

# Service Manual

**PIONEER**  
The Art of Entertainment

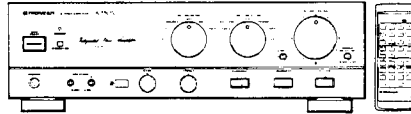

The above illustration shows the model A-550R.

ORDER NO.  
**ARP2305**

## STEREO AMPLIFIER

# A-550R

## A-550R-S

## A-450R

A-550R, A-550R-S AND A-450R HAVE THE FOLLOWING :

Type	Model			Power Requirement	Remarks
	A-550R	A-550R-S	A-450R		
HE	○	—	○	AC220V-230V, 240V (Switchable)*	
HEWZ	○	○	○	AC220V-230V, 240V (Switchable)*	

\* Change the connection of the power transformer's primary wiring.

- This manual is applicable to the A-550R/HE, HEWZ, A-550R-S/HEWZ, A-450R/HE and HEWZ types.
- The A-550R-S is the same as the A-550R except for color.
- Ce manuel pour le service comprend les explications de réglage en français.
- Este manual de servicio trata del método ajuste escrito en español.

## CONTENTS

1. EXPLODED VIEWS, PACKING AND PARTS LIST .....	2	5. ADJUSTMENT .....	28
2. SCHEMATIC DIAGRAM .....	7	5. RÉGLAGE .....	29
3. P.C. BOARDS CONNECTION DIAGRAM .....	12	5. AJUSTE .....	30
4. PCB's PARTS LIST .....	21	6. PANEL FACILITIES .....	31
		7. SPECIFICATIONS .....	33

**PIONEER ELECTRONIC CORPORATION** 4-1, Meguro 1-Chome, Meguro-ku, Tokyo 153, Japan  
**PIONEER ELECTRONICS SERVICE INC.** P.O. Box 1760, Long Beach, California 90801 U.S.A.  
**PIONEER ELECTRONICS OF CANADA, INC.** 505 Cochrane Drive, Markham, Ontario L3R 8E3 Canada  
**PIONEER ELECTRONIC [EUROPE] N.V.** Keetberglaan 1, 9120 Beveren, Belgium  
**PIONEER ELECTRONICS AUSTRALIA PTY. LTD.** 178-184 Boundary Road, Braeside, Victoria 3195, Australia TEL: [03] 580-9911  
 © PIONEER ELECTRONIC CORPORATION 1991

DX JULY 1991 Printed in Japan

## 1. EXPLODED VIEWS, PACKING AND PARTS LIST

### NOTES:

- The parts with an encircled number are generally unavailable because they are not in our Master Spare Parts List.
- The  $\Delta$  mark found on some component parts indicates the importance of the safety factor of the part. Therefore, when replacing, be sure to use parts of identical designation.
- Parts marked by "●" are not always kept in stock. Their delivery time may be longer than usual or they may be unavailable.

### 1.1 PARTS LIST OF A - 550R AND A - 550R - S TYPES

Mark	No.	Description	Parts No.	Mark	No.	Description	Parts No.
	1	ROTARY KNOB S (BASS, TREBLE)	AAB1155		26	CUSHION (RUBBER)	AEB1074
	1	ROTARY KNOB S (BASS, TREBLE) (A - 550R - S type)	AAB1238		27	CUSHION C (RUBBER)	AEB - 270
	2	ROTARY KNOB L (VOLUME CONTROL)	AAB1160		28	NYLON BINDER	AEC - 093
	2	ROTARY KNOB L (VOLUME CONTROL) (A - 550R - S type)	AAB1161		29	RIVET	AEC - 441
	3	ROTARY KNOB R (PLS)	AAB1162		30	STRAIN RELIEF	AEC - 882
	3	ROTARY KNOB R (A - 550R - S type)	AAB1163		31	.....	
	4	ROTARY KNOB M (REC/INPUT SELECTOR)	AAB1231	●	32	LED ASSEMBLY	AWZ3495
	4	ROTARY KNOB M (REC/INPUT SELECTOR) (A - 550R - S type)	AAB1236		33	CONTROL ASSEMBLY	AWZ3496
	5	PUSH KNOB (STANDBY)	AAD1246		34	ROTARY FUNC. ASSEMBLY	AWZ3497
	5	PUSH KNOB (STANDBY) (A - 550R - S type)	AAD2033		35	DRY CELL BATTERY (R03, AAA)	AEX - 021
	6	PUSH KNOB C (SPEAKERS, DIRECT, PHONO SELECTOR)	AAD1366		36	STYROL PROTECTOR	AHA1335
	6	PUSH KNOB C (SPEAKERS, DIRECT, PHONO SELECTOR) (A - 550R - S type)	AAD1367		37	PACKING CASE	AHD2130
	7	PUSH KNOB (SUBSONIC, LOUDNESS)	AAD1536		37	PACKING CASE (A - 550R - S type)	AHD2131
	7	PUSH KNOB (SUBSONIC, LOUDNESS) (A - 550R - S type)	AAD1538		38	EYE ASSEMBLY	AWZ3498
	8	POWER KNOB	AAD1984		39	PACKING SHEET	AHG1016
	8	POWER KNOB (A - 550R - S type)	AAD2040		40	TERMINAL SCREW	AKE - 031
	9	TACT KNOB (MUTING)	AAD2003		41	PLUG	AKM1004
	9	TACT KNOB (MUTING) (A - 550R - S type)	AAD2032	$\Delta$	42	AC SOCKET 3 - P	AKP - 502
	10	SENSOR WINDOW	AAK1783		43	PANEL BASE	AMB1651
	11	POWER SW ASSEMBLY	AWZ3493		43	PANEL BASE (A - 550R - S type)	AMB1652
	12	NAME PLATE (METAL)	AAM1029		44	INDICATING LENS	AMR1160
	13	SCREW	ABA - 298		45	INSULATOR ASSY	AMR2140
	14	SCREW (STEEL)	ABA1009		46	ARM	AMR2142
	15	SCREW (STEEL)	ABA1011		47	MICA SHEET	AMR2295
	16	SCREW (STEEL)	ABA1016		48	CHASSIS	ANA1065
	17	SCREW (STEEL)	ABA1047		49	FRONT PANEL	ANB1462
	18	SCREW (STEEL)	ABA1048		49	FRONT PANEL (A - 550R - S type)	ANB1477
	19	SCREW (STEEL)	ABA1050		50	REAR PANEL	ANC1712
	20	SCREW	ABA1082		51	SHIELD ASSEMBLY	AWZ2860
	21	BUSH	ABF1018		52	BOTTOM PLATE	ANF1085
	22	SPRING	ABH - 052		53	PCB HOLDER	ANG1198
	23	SPRING	ABH1034		54	HEAT SINK HOLDER	ANG1340
	24	NUT	ABN - 065		55	PCB HOLDER	ANG1580
$\Delta$	25	AC POWER CORD	ADG1049		56	HEAT SINK	ANH1259
				●	57	SUB HEAT SINK	ANH1325
				●	58	ROD	ANR - 879
					59	OPERATING INSTRUCTIONS (English, French, German, Italian, Dutch, Swedish, Spanish, Portugues) (HE type)	ARE1201
					59	OPERATING INSTRUCTIONS (German) (HEWZ type)	ARC1278
					60	HEADPHONE ASSEMBLY	AWZ3484
				●	61	AF COMPLEX ASSEMBLY	AWZ3487
				●	62	TONE ASSEMBLY	AWZ3491

Mark	No.	Description	Parts No.
	63	REMOTE CONTROL UNIT (CU - A001)	AXD1211
	64	BONNET CASE	AZN1799
	64	BONNET CASE (A - 550R - S type)	AZN1800
	65	SCREW	BBT30P060FZK
	65	SCREW (A - 550R - S type)	ABA - 274
	66	SCREW	BBT30P080FZK
	67	NUTS	NK90FZB
	68	BATTERY COVER	PZN1001
	69	SCREW	VMZ30P060FCU
△	70	POLYESTER CAPACITOR (C1)	CQMXA104J100
△	71	FUSE (T2.5A, FU1)	AEK - 512
△	72	TRANSISTOR (Q1)	2SC3281
△	73	TRANSISTOR (Q2)	2SC3281
△	74	TRANSISTOR (Q3)	2SA1302
△	75	TRANSISTOR (Q4)	2SA1302
△	76	TRANSISTOR (Q5)	2SC4137
△	77	TRANSISTOR (Q6)	2SC4137
△	78	CARBON FILM RESISTOR (R3)	RD1/4PM010J
	79	SWITCH (S2)	ASU1036
△	80	POWER TRANSFORMER (T1)	ATS1368
	81	FUSE ASSEMBLY	AWZ3516
△	82	CARBON FILM RESISTOR (R1, RD1/4PMF100J HEWZ type only)	
△	83	CARBON FILM RESISTOR (R2, RD1/4PMF100J HEWZ type only)	
	84	BINDER	AEF1004
	85	VINYL BAG	AHG - 117

## 1.2 PARTS LIST OF A - 450R TYPE

Mark	No.	Description	Parts No.
	1	ROTARY KNOB S (BASS, TREBLE)	AAB1155
	2	ROTARY KNOB L (VOLUME CONTROL)	AAB1160
	3	ROTARY KNOB R (PLS)	AAB1162
	4	ROTARY KNOB M (REC/INPUT SELECTOR)	AAB1237
	5	PUSH KNOB (STANDBY)	AAD1246
	6	PUSH KNOB C (SPEAKERS, DIRECT, PHONO SELECTOR)	AAD1366
	7	PUSH KNOB (SUBSONIC, LOUDNESS)	AAD1536
	8	POWER KNOB	AAD1984
	9	TACT KNOB (MUTING)	AAD2003
	10	SENSOR WINDOW	AAK1783
	11	POWER SW ASSEMBLY	AWZ3493
	12	NAME PLATE (METAL)	AAM1029
	13	SCREW	ABA - 298
	14	SCREW (STEEL)	ABA1009
	15	SCREW (STEEL)	ABA1011
	16	SCREW (STEEL)	ABA1016
	17	SCREW (HE type only)	ABA1047
	18	SCREW (STEEL)	ABA1048
	19	SCREW (STEEL)	ABA1050
	20	SCREW	ABA1082
	21	.....	
	22	SPRING	ABH - 052
	23	SPRING	ABH1034
	24	NUT	ABN - 065
△	25	AC POWER CORD	ADG1049
	26	CUSHION (RUBBER)	AEB1074
	27	CUSHION C (RUBBER)	AEB - 270
	28	NYLON BINDER	AEC - 093
	29	RIVET	AEC - 441
	30	STRAIN RELIEF	AEC - 882
	31	.....	
●	32	LED ASSEMBLY	AWZ3495
	33	CONTROL ASSEMBLY	AWZ3496
	34	ROTARY FUNC. ASSEMBLY	AWZ3497
	35	DRY CELL BATTERY (R03, AAA)	AEX - 021
	36	STYROL PROTECTOR	AHA1335
	37	PACKING CASE	AHD2132
	38	EYE ASSEMBLY	AWZ3498
	39	PACKING SHEET	AHG1016
	40	TERMINAL SCREW	AKE - 031
	41	PLUG	AKM1004
△	42	AC SOCKET 3-P	AKP - 502
	43	PANEL BASE	AMB1651
	44	INDICATING LENS	AMR1160
	45	INSULATOR ASSY	AMR2140
	46	.....	
	47	MICA SHEET	AEE1014
	48	CHASSIS	ANA1065

Mark	No.	Description	Parts No.
	49	FRONT PANEL	ANB1463
	50	REAR PANEL	ANC1712
	51	SHIELD ASSEMBLY	AWZ2860
	52	BOTTOM PLATE	ANF1085
	53	PCB HOLDER	ANG1198
	54	HEAT SINK HOLDER	ANG1340
	55	PCB HOLDER	ANG1580
	56	HEAT SINK	ANH1333
	57	.....	
	58	ROD	ANR-879
	59	OPERATING INSTRUCTIONS (English, French, German, Italian, Dutch, Swedish, Spanish, Portugues) (HE type)	ARE1201
	59	OPERATING INSTRUCTIONS (German) (HEWZ type)	ARC1278
	60	HEADPHONE ASSEMBLY	AWZ3484
●	61	AF COMPLEX ASSEMBLY	AWZ3489
●	62	TONE ASSEMBLY	AWZ3492
	63	REMOTE CONTROL UNIT (CU - A001)	AXD1211
	64	BONNET CASE	AZN1799
	65	SCREW	BBT30P060FZK
	66	SCREW	BBT30P080FZK
	67	NUTS	NK90FZB
	68	BATTERY COVER	PZN1001
	69	SCREW	VMZ30P060FCU
△	70	POLYESTER CAPACITOR (C1) (HE type)	CQMXA473J100
△	70	POLYESTER CAPACITOR (C1) (HEWZ type)	CQMXA104J100
△	71	FUSE (T2.5A, FU1)	AEK-512
△	72	TRANSISTOR (Q1)	2SC3281N
△	73	TRANSISTOR (Q2)	2SC3281N
△	74	TRANSISTOR (Q3)	2SA1264N
△	75	TRANSISTOR (Q4)	2SA1264N
△	76	TRANSISTOR (Q5)	2SC4137
△	77	TRANSISTOR (Q6)	2SC4137
△	78	CARBON FILM RESISTOR (R3)	RD1/4PM010J
	79	SWITCH (S2)	ASU1036
△	80	POWER TRANSFORMER (T1)	ATS1367
	81	FUSE ASSEMBLY	AWZ3516
△	82	CARBON FILM RESISTOR (R1, RD1/4PMF100J HEWZ type only)	
△	83	CARBON FILM RESISTOR (R2, RD1/4PMF100J HEWZ type only)	
	84	BINDER	AEF1004
	85	VINYL BAG	AHG-117

### 1.3 PACKING

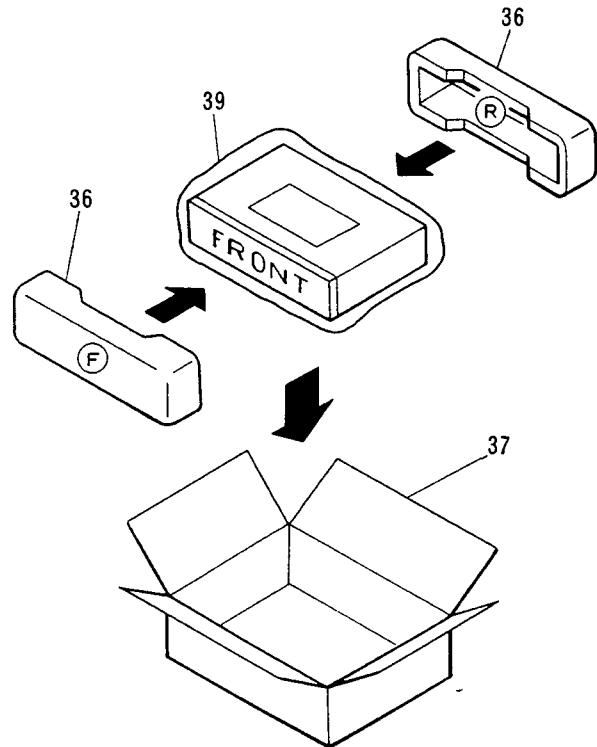
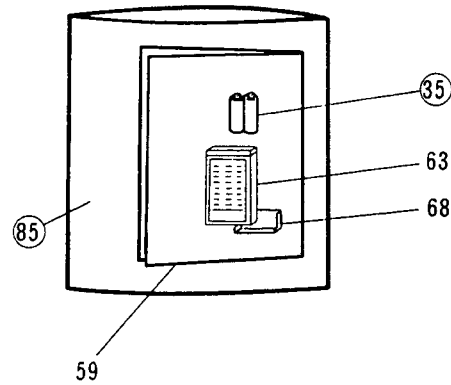

### 1.4 EXTERIOR

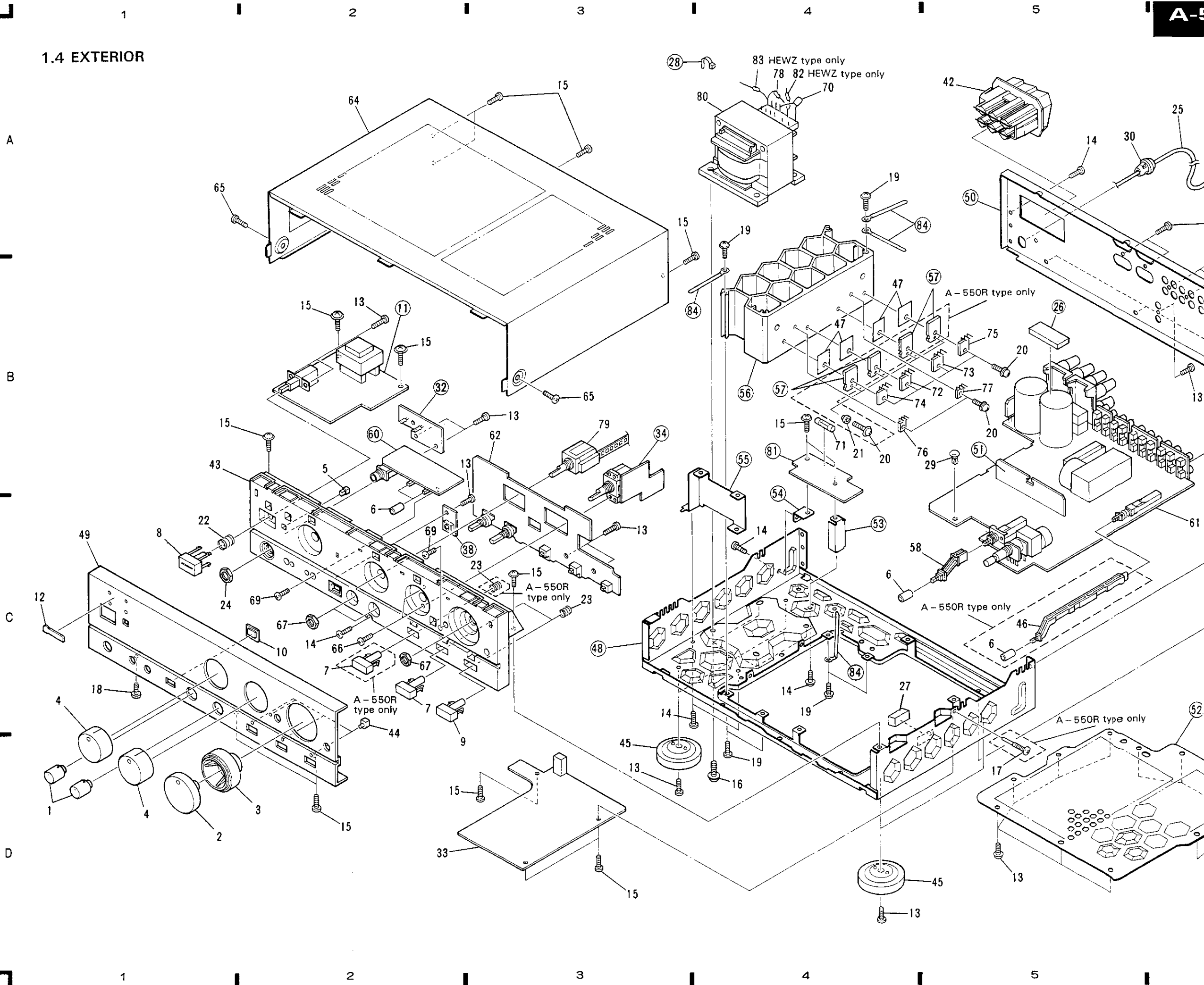

1.4 EXTERIOR

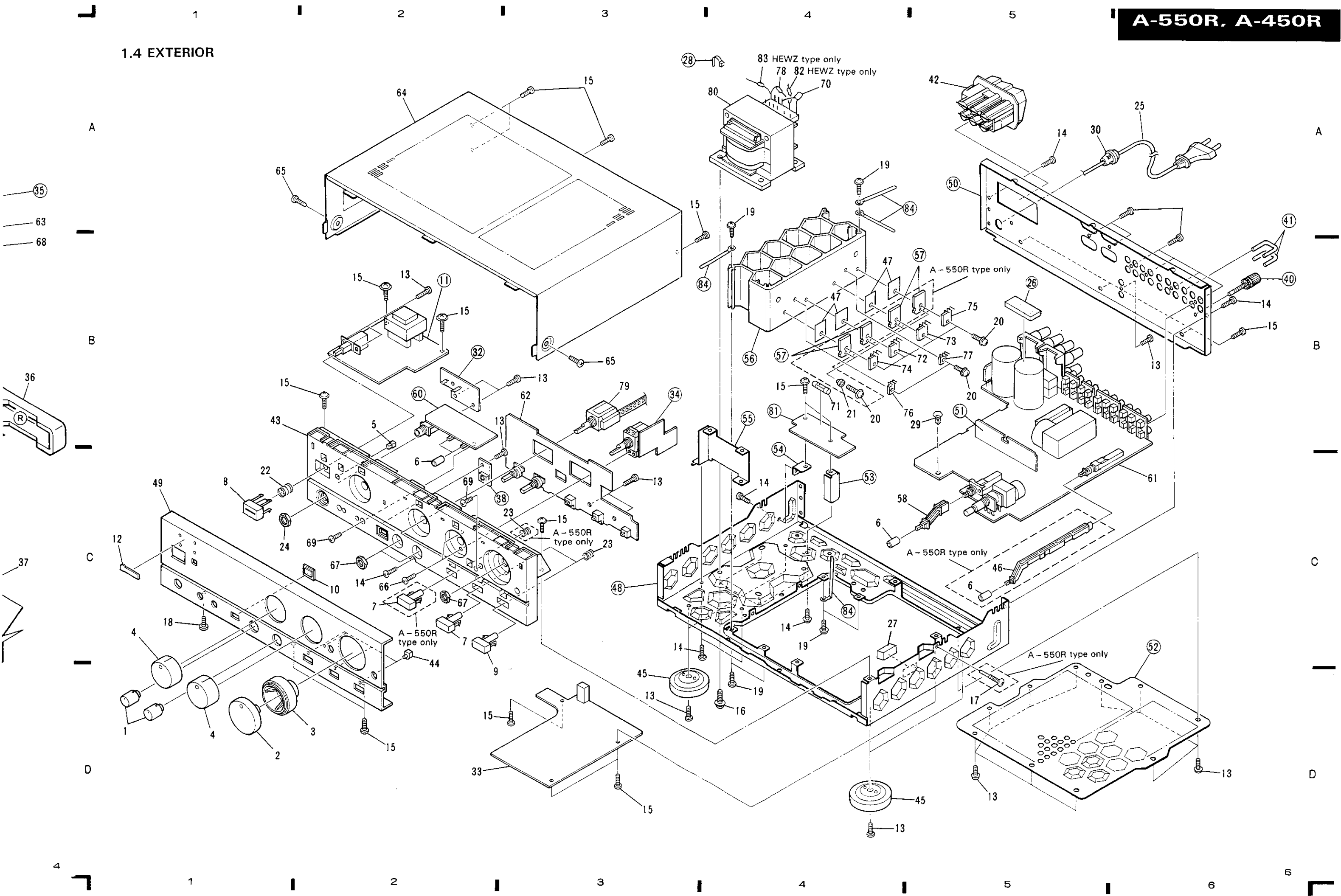

2. SCHEMATIC DIAGRAM

2

3

4

5

6

7

Aa to the A-450R type refer to page 11.

Figures enclosed in ( ) for A-450R TYPE.

Q201-Q204, Q211, Q212, Q215-Q234, Q237, Q238 POWER AMP

IC101 UPC4570C(A-550R) MS20CPI(A-450R)

D507 D217-220

- Q203-208, 215-218, 25A1048
- Q305 25A1145
- Q231, 232 25A1305
- Q223, 224 25A992
- Q229, 230, 233, 234 25C1815
- Q238, 291-294 25C1845
- Q306 25C2458
- Q211, 212, 227, 228 25C2458
- Q237, 301, 302 25C2458
- Q105, 106 25C2458
- (A-550R ONLY) 25C2458
- Q303, 304, 307 25C2603
- Q225, 226 25C2603
- Q219, 220 25C2705
- Q221, 222 25C3298
- Q101-104 25K359
- (A-550R ONLY)

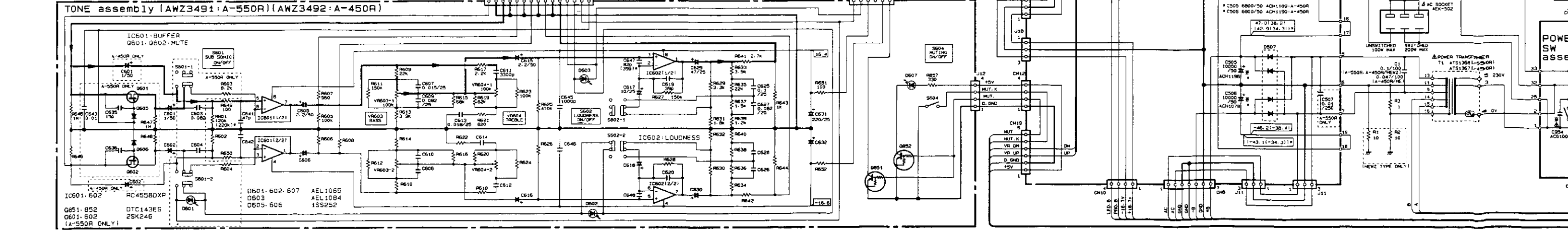
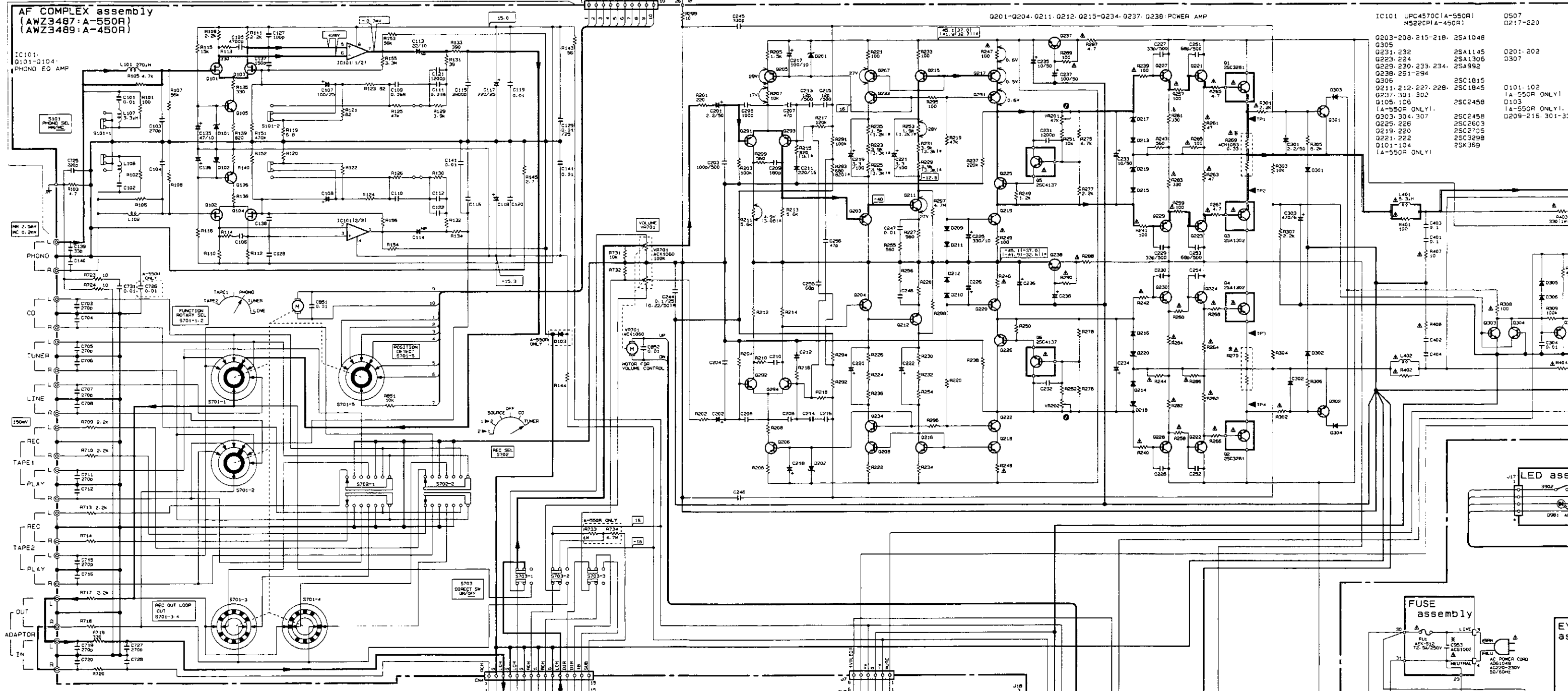

7

1

2

3

4

5

6

7

IC101 UPC4570C (A-550R) MS220P(A-450R)	D507 D217-220	D55820P RD15ESB (A-550R1) RD8.2ESB1 (A-450R1) RD2.7ESB1 RD22ESB (A-550R1) RD15ESB (A-450R1) RD7.5ESB2
Q203-208, 215-218, 25A1048 Q305 Q231, 232 Q223, 224 Q229, 230, 233, 234 Q238, 291-294 Q306 Q211, 212, 227, 228 Q237, 301, 302 Q105, 106 (A-550R ONLY) Q303, 304, 307 Q226, 226 Q219, 220 Q221, 222 Q101-104 (A-550R ONLY)	25A1145 25A1306 25A992 25C1815 25C1845 25C2458 25C2458 25C2603 25C2705 25C3298 25K369	D201, 202 D307 D101, 102 (A-550R ONLY) D103 (A-550R ONLY) D209-216, 301-306 15S252

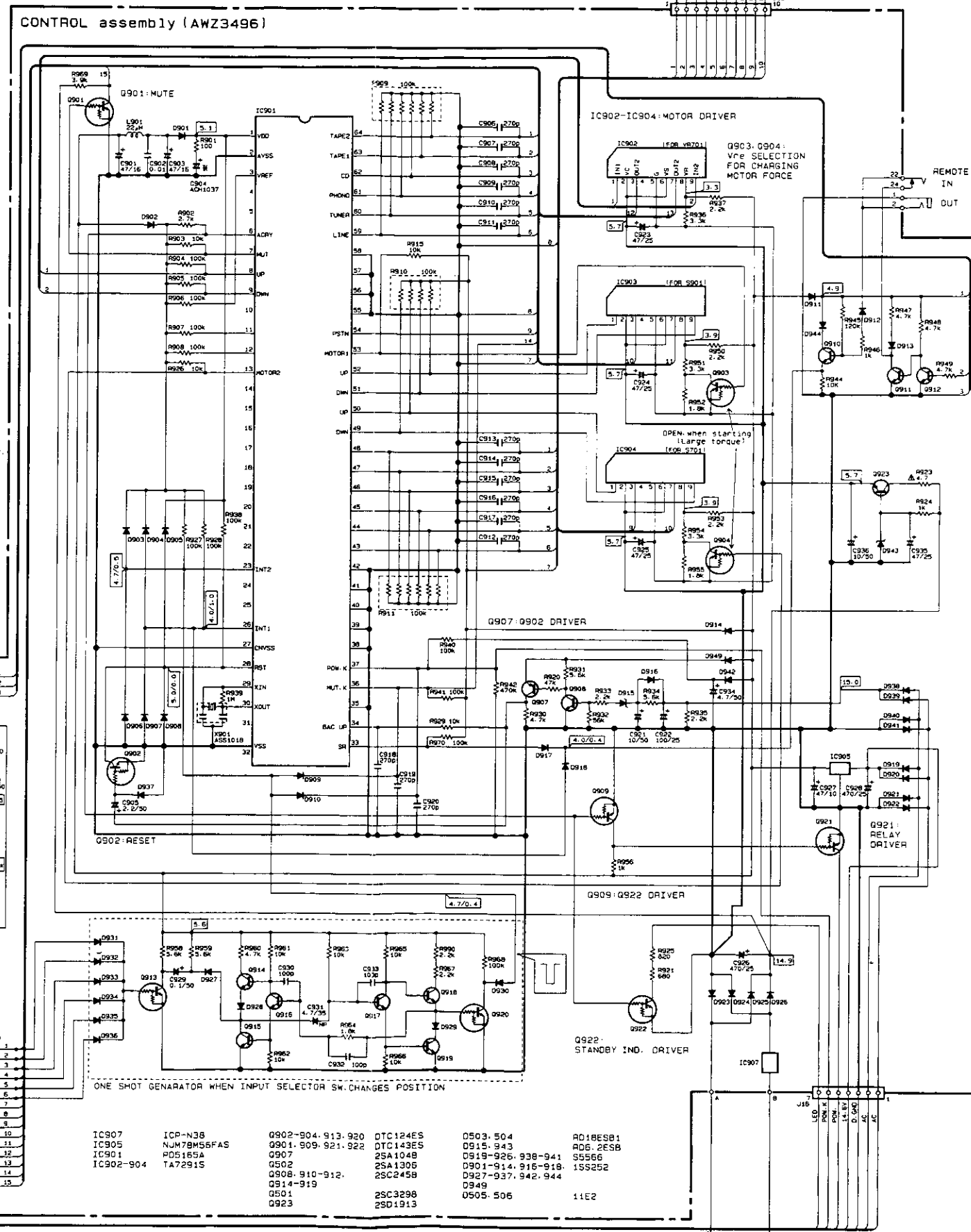
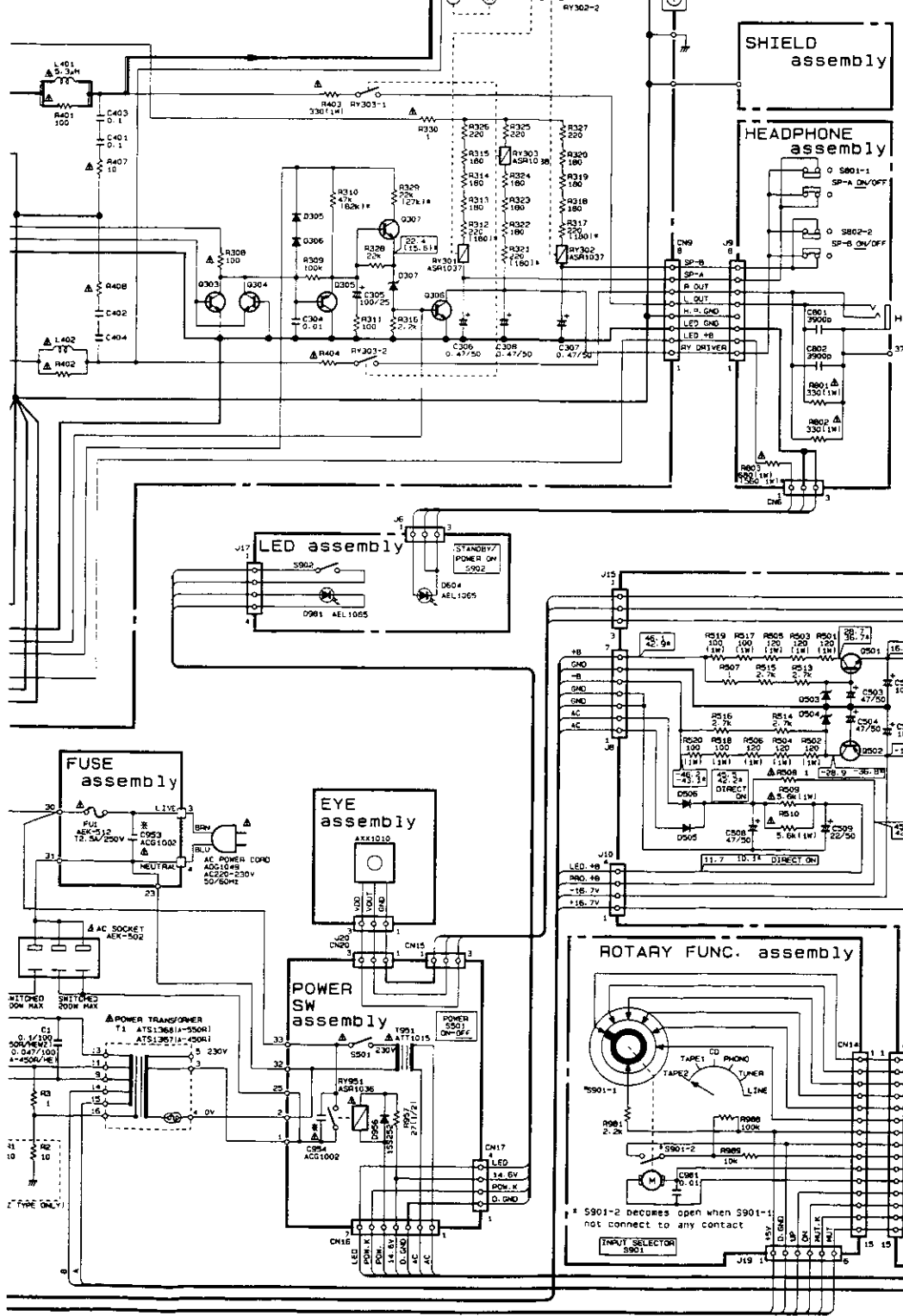

IC907 ICP-N38	Q902-904, 913-920 DTC124ES	O503, 504 O515, 943	RD18ESB1
IC905 NJM78M56FAS	Q901, 909, 921, 922 DTC143ES	O519-926, 938-941 S5566	RD6.2ESB
IC901 PD5185A	Q907 25A1048	D901-914, 916-918, 15S252	15S252
IC902-904 TA72915	O502 25A1306	D927-937, 942-944 D949	11E2
	O508, 910-912, O501	25C2458	
	O514-919, O501		
	O501	25C3298	
	O923	25D1913	

- RESISTORS:**  
Indicated in  $\Omega$ ,  $k\Omega$ ,  $M\Omega$ , 5% tolerance unless otherwise noted k: k $\Omega$ , M: M $\Omega$ , (F): 1%, (G): 2%, (K): 10% (M): 20% tolerance
- CAPACITORS:**  
Indicated in capacity ( $\mu$ F)/voltage (V) unless otherwise noted p: pF indication without voltage is 50V except electrolytic capacitor.
- VOLTAGE, CURRENT:**  
Signal voltage at ( W + W 8i)/output (1k $\Omega$ )  
DC voltage (V) at no input signal  
Value in ( ) is DC voltage at rated power.  
mA: DC current at no input signal
- OTHERS:**  
Signal route.  
Adjusting point.  
The  $\Delta$  mark found on some component parts indicates the importance of the safety factor of the part. Therefore, when replacing, be sure to use parts of identical designation.  
marked capacitors and resistors have parts numbers.

This is the basic schematic diagram, but the actual circuit may vary due to improvements in design.

- SWITCHES**
- POWER SW assembly
    - S501 POWER
  - ROTARY FUNC. assembly
    - S901 ROTARY SW
  - LED assembly
    - S902 STANDBY
  - AF COMPLEX assembly
    - S101 PHONO SEL MM/MC (A-550R ONLY)
    - S701 FUNCTION REC SEL
    - S702 FUNCTION
    - S703 DIRECT SW ON/OFF
  - TONE assembly
    - S601 SUB SONIC ON/OFF (A-550R ONLY)
    - S602 LOUDNESS
    - S604 MUT.K
  - HEADPHONE assembly
    - S801-1 SP-A ON/OFF
    - S801-2 SP-B ON/OFF

- LINE VOLTAGE SELECTION**
- Line voltage can be changed with the following steps.
- Disconnect the AC Power cord.
  - Remove the top cover.
  - Change the connection of the power transformer primary pins.

Voltage	Power transformer Pin No.
220V	3
240V	5

Part No.	Description
AAX-193	220V label
AAX-192	240V label



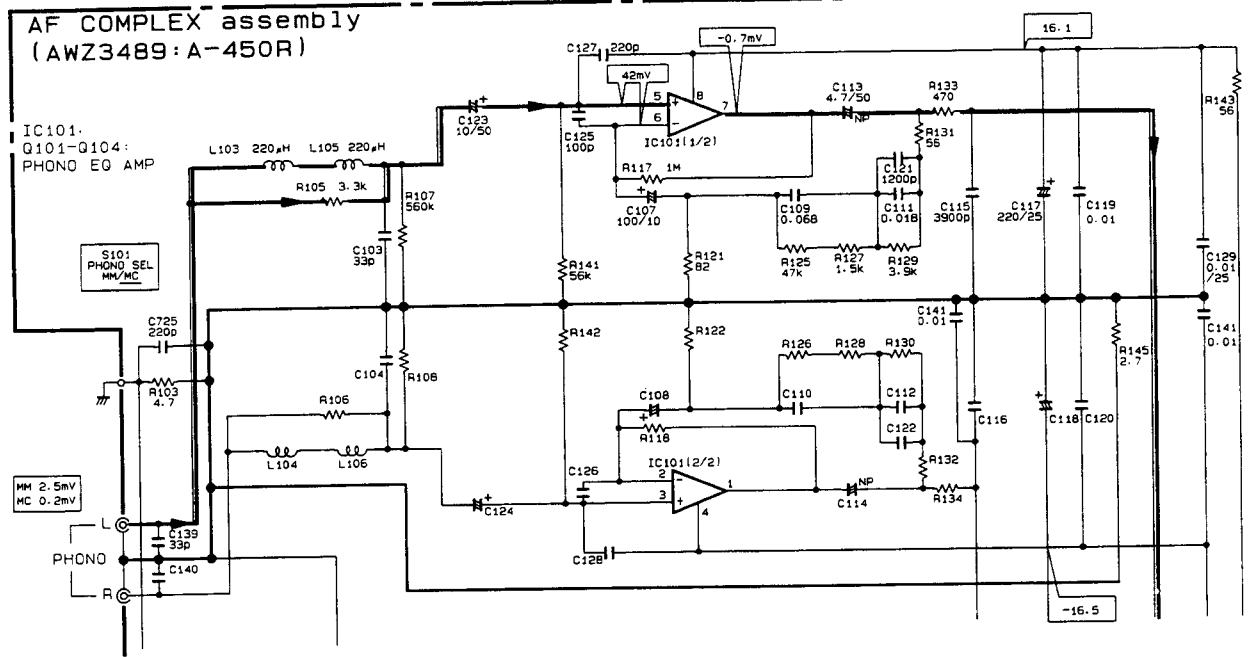

- Parts with asterisk (\*) differs according to models as follows ;

### AF COMPLEX ASSEMBLY

Parts No.	A-550R and A-550R-S	A-450R
	AWZ3487	AWZ3489
IC101	UPC4570C	M5220P
Q101-Q104	2SK369	VACANT
Q105, Q106	25C245B	VACANT
D101, D102	RD7.5ESB2	VACANT
D103	1SS252	VACANT
Q217-D220	RD15ESB	RD8.2ESB1
D307	RD22ESB	RD15ESB
S101	ASG1012	VACANT
RY301, RY302	ASR1037	ASR103B
L101, L102	ATH1010	VACANT
L103-L106	VACANT	LAU221K
L107, L108	LAU3R9K	VACANT
C101, C102	CFTXA103J50	VACANT
C103, C104	CCCSL271J50	CCCSL330J50
C105, C106	CKCYB472K50	VACANT
C107, C108	CEXA101M25	CEAS101M10
C113, C114	CEANP220M10	CEAS4R7M50
C117, C118	CEXA221M25	CEAS221M25
C123, C124	VACANT	CEAS100M50
C125, C126	VACANT	CCCSL101J50
C127, C128	CCCSL101J50	CCDSL221J50
C135, C136	CEAS470M10	VACANT
C137, C138	CCCSL151J50	VACANT
C139, C140	CCCSL330J50	CCDSL330J50
C139, C140	CCCSL330J50	CCDSL330J50
C244	CKDYX104M25	CQMA224K50
C506	ACH1078	ACH1190
C507	CQMA103K250	VACANT
C725	CCDSL221J50	CCCSL221J50
C726	CKCYF103Z50	VACANT

Parts No.	A-550R and A-550R-S	A-450R
	AWZ3487	AWZ3489
R101, R102	RDR1/8PU101J	VACANT
R105, R106	RD1/8PM472J	RD1/8PM332J
R107, R108	RDR1/8PU563J	RD1/8PM564J
R109-R112	RD1/8PM222J	VACANT
R113, R114	RD1/8PM331J	VACANT
R115, R116	RD1/8PM153J	VACANT
R117, R118	VACANT	RD1/8PM105J
R119, R120	RDR1/4PM6R8J	VACANT
R123, R124	RD1/8PM820J	VACANT
R127, R128	VACANT	RD1/8PM152J
R131, R132	RD1/8PM390J	RD1/8PM560J
R133, R134	RDR1/8PU391J	RDR1/8PU471J
R135, R136	RD1/8PM331J	VACANT
R139, R140	RD1/8PM821J	VACANT
R141, R142	VACANT	RDR1/8PU563J
R151, R152	RD1/8PM474J	VACANT
R153, R154	RD1/8PM563J	VACANT
R155, R156	RD1/8PM335J	VACANT
R215, R216	RDR1/4PM821J	RDR1/4PM102J
R223-R226	VACANT	VACANT
R229-R232	RD1/4PM392J	RD1/4PM332J
R235, R236	VACANT	VACANT
R253, R254	RD1/8PM152J	RD1/8PM122J
R287, R288	RD1/4PMF4R7J	RFA1/4PS4R7J
R293, R294	RD1/8PM681J	RD1/8PM821J
R310	RD1/8PM473J	RD1/8PM823J
R312, R317, R321	RD1/4PM221J	RD1/4PM181J
R329	RD1/8PM223J	RD1/8PM273J
R733	RD1/8PM105J	VACANT
R734	RD1/8PM475J	VACANT

### PHONE ASSEMBLY

Parts No.	A-550R and A-550R-S	A-450R
	AWZ3491	AWZ3492
Q601, Q602	2SK246	VACANT
D601	AEL1065	VACANT
D605, D606	1SS252	VACANT
S601	ASG1019	VACANT
C603, C604	CFTXA823J50	VACANT
C635, C636	CCDSL150J50	VACANT
C643	CKCYF103Z50	VACANT
C647, C648	CCCSL820J50	CCDSL390J50
R601, R602	RD1/8PM124J	RD1/8PM224J
R603, R604	RD1/8PM822J	VACANT
R647, R648	RD1/8PM105J	VACANT





### HEADPHONE ASSEMBLY

Parts No.	A-550R and A-550R-S	A-450R
	Non supply	Non supply
R803	RS1LMF681J	RS1LMF561J

### 3. P.C.BOARDS CONNECTION DIAGRAM

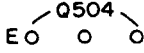
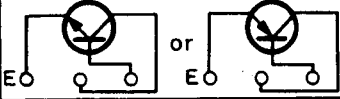
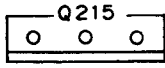
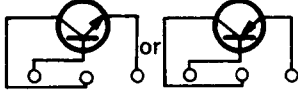
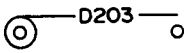
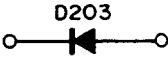
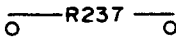
**NOTE**

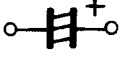
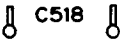
1. This P.C.B connection diagram is viewed from the parts mounted side.
2. The parts which have been mounted on the board can be replaced with those shown with the corresponding wiring symbols listed in the following Table.

P.C.B. pattern diagram indication	Corresponding part symbol	Part Name
		Transistor
		Radiator type transistor
		Diode
		Resistor
		Capacitor (Polarity)
		Capacitor (Non-polarity)

**Others**

P.C.B. pattern diagram indication	Part Name
IC	IC
S	Switch
RY	Relay
L	Coil
F	Filter
VR	Variable resistor or Semi-fixed resistor

3. The capacitor terminal marked with ⊙ (double circles) shows negative terminal.
4. The diode terminal marked with ⊙ (double circles) shows cathode side.
5. The transistor terminal to which E is affixed shows the emitter.

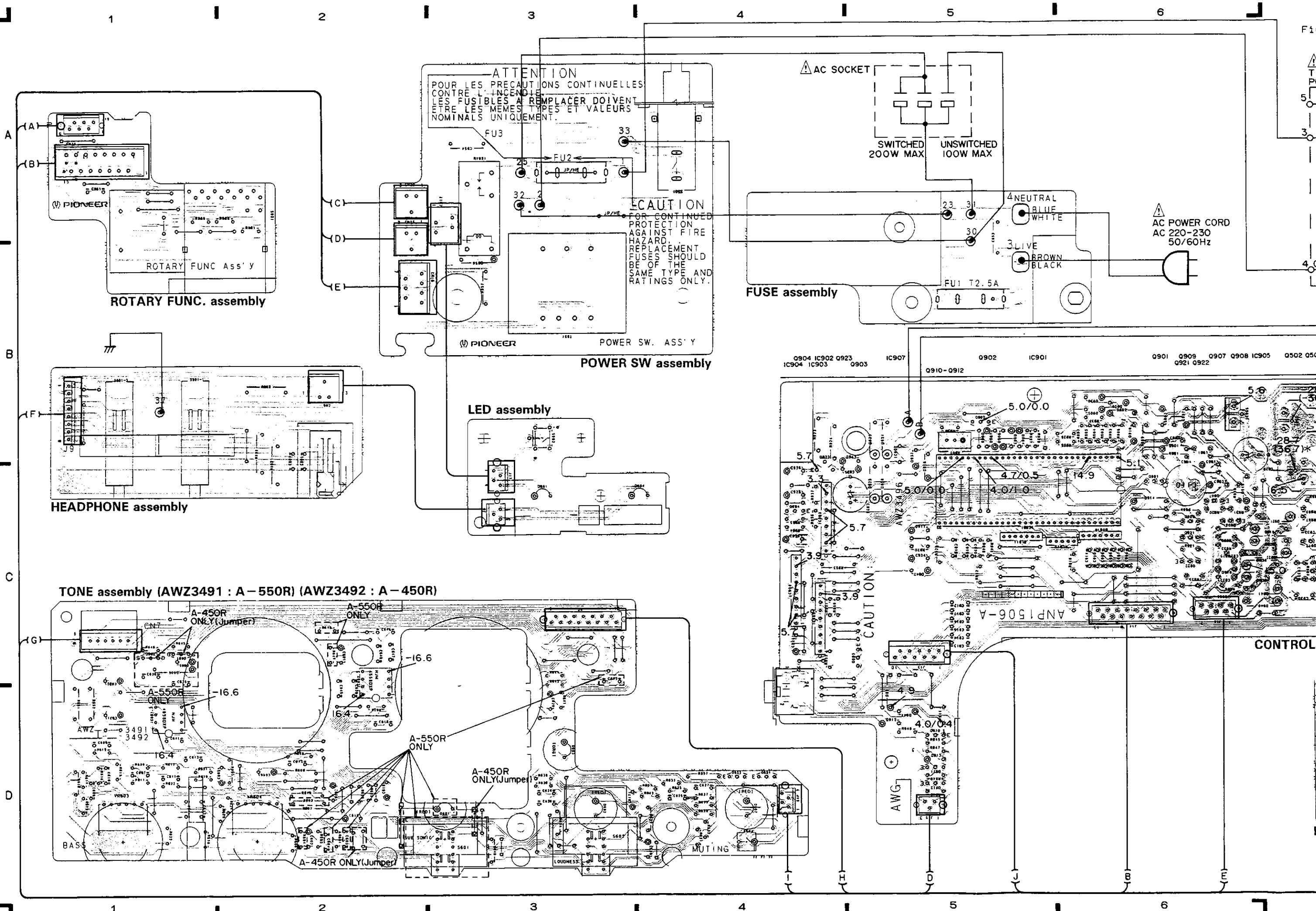

1 | 2 | 3 | 4 | 5 | 6

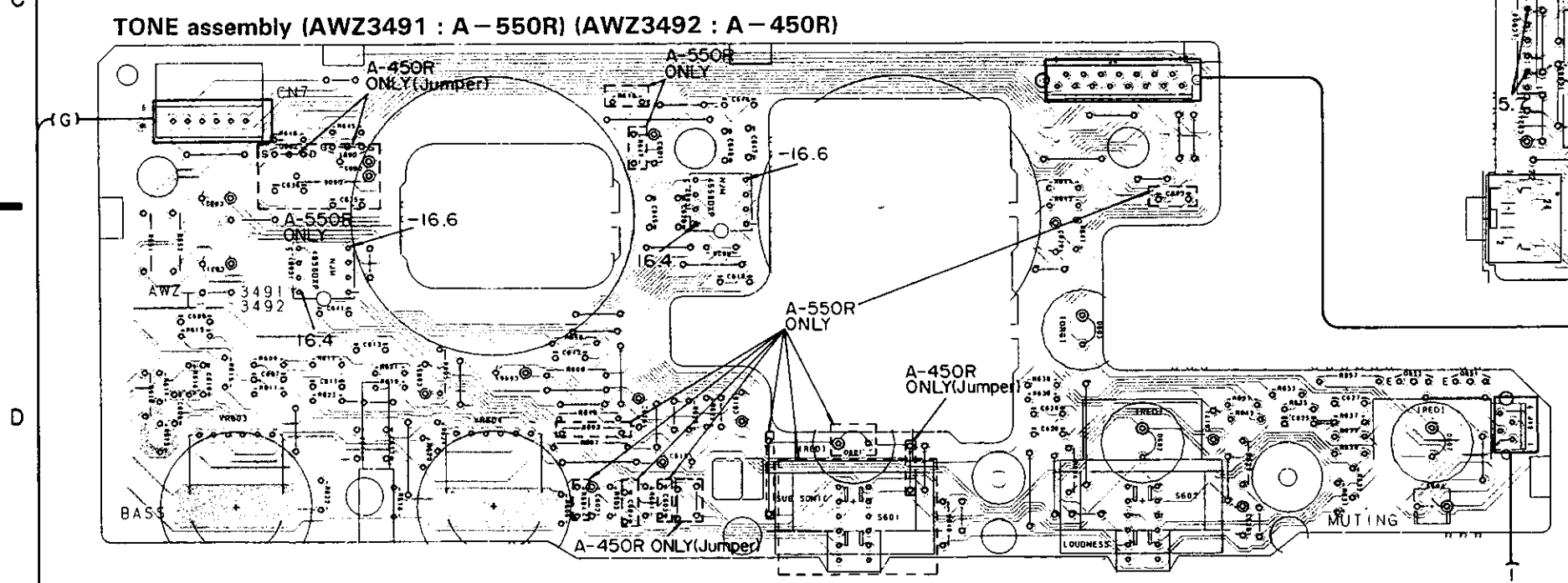
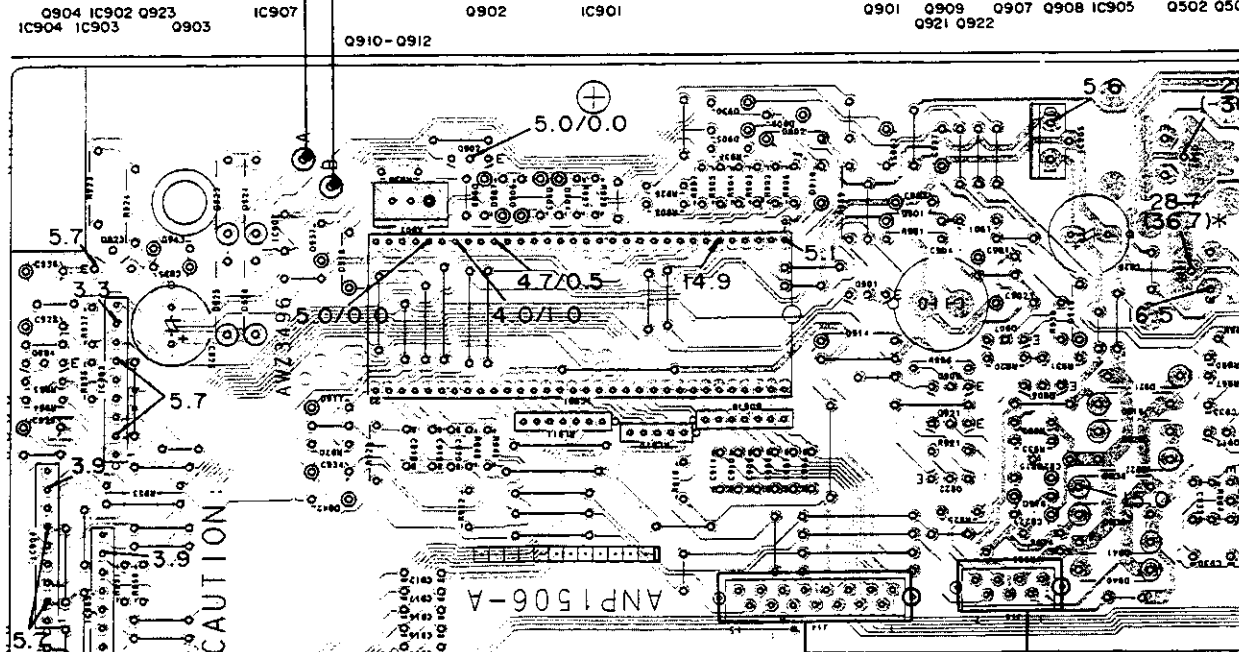
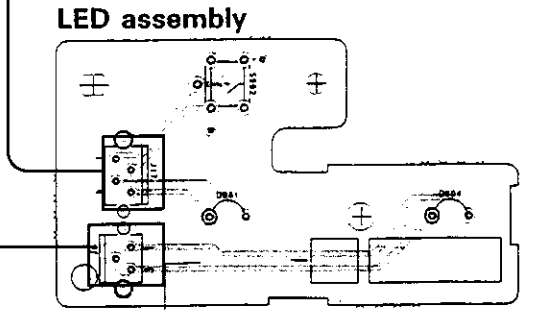
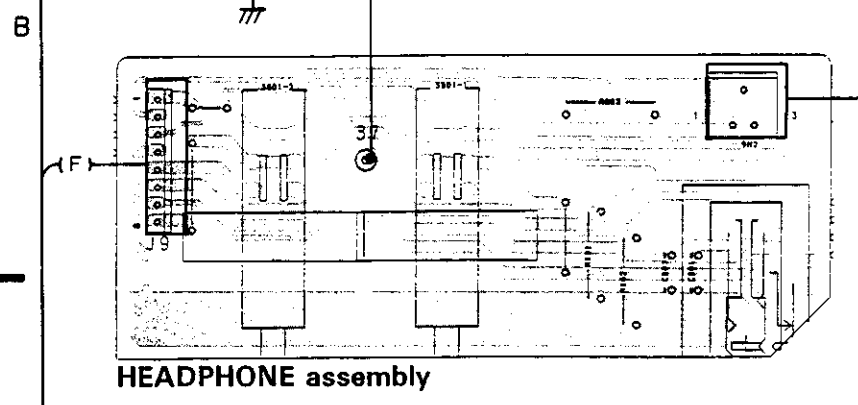
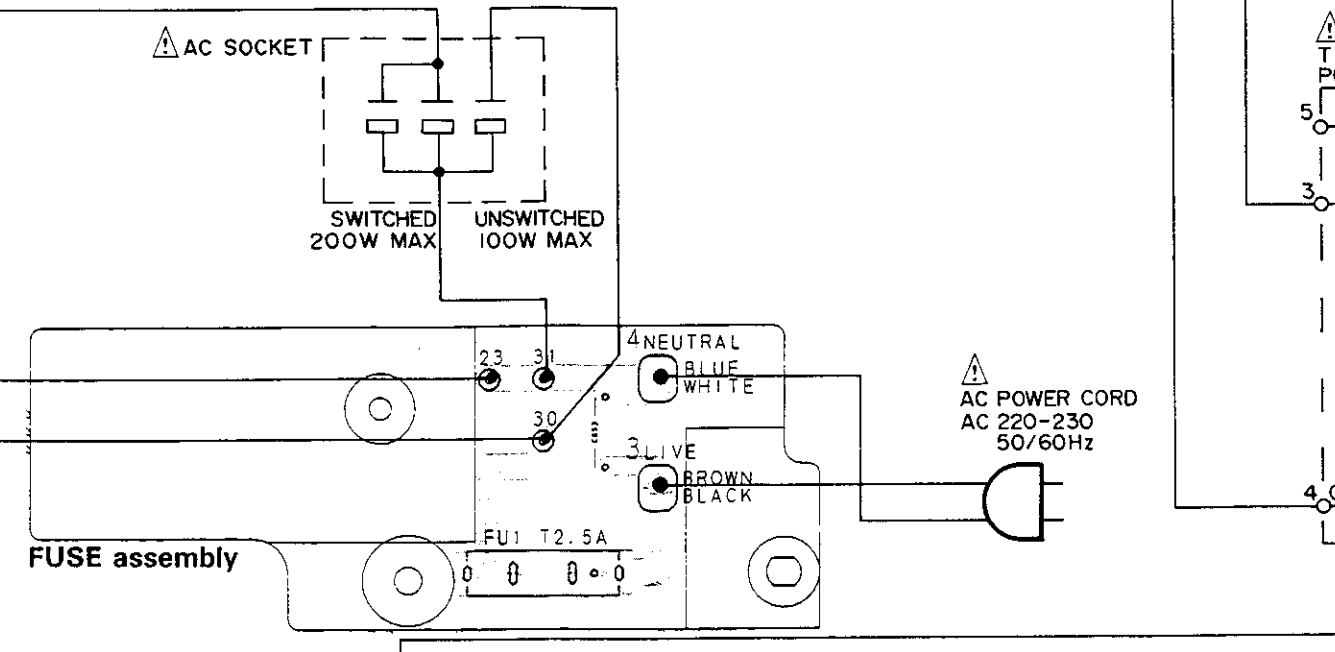
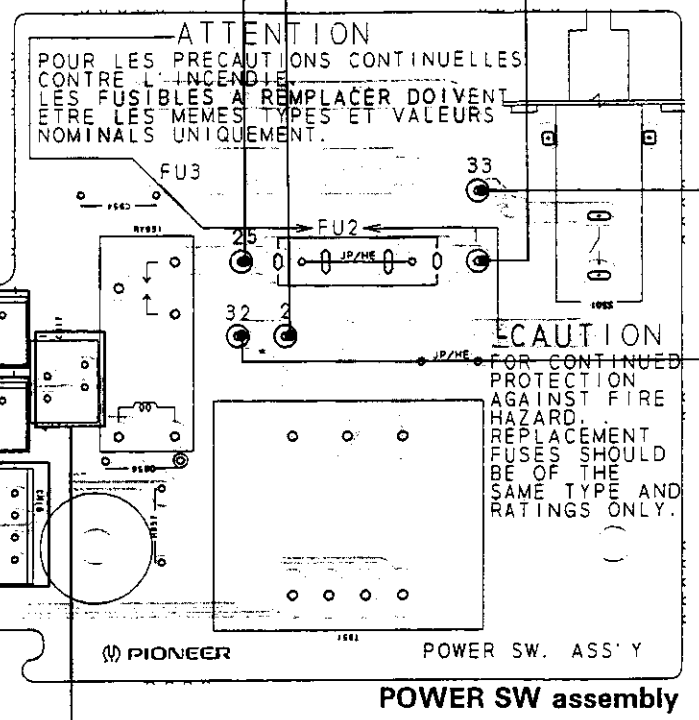
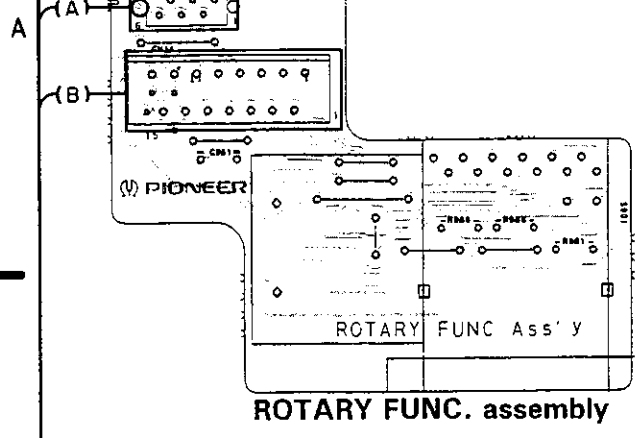

1 | 2 | 3 | 4 | 5 | 6

F10

5

3

4

E

Figures enclosed in ( )\* for A-450R TYPE.

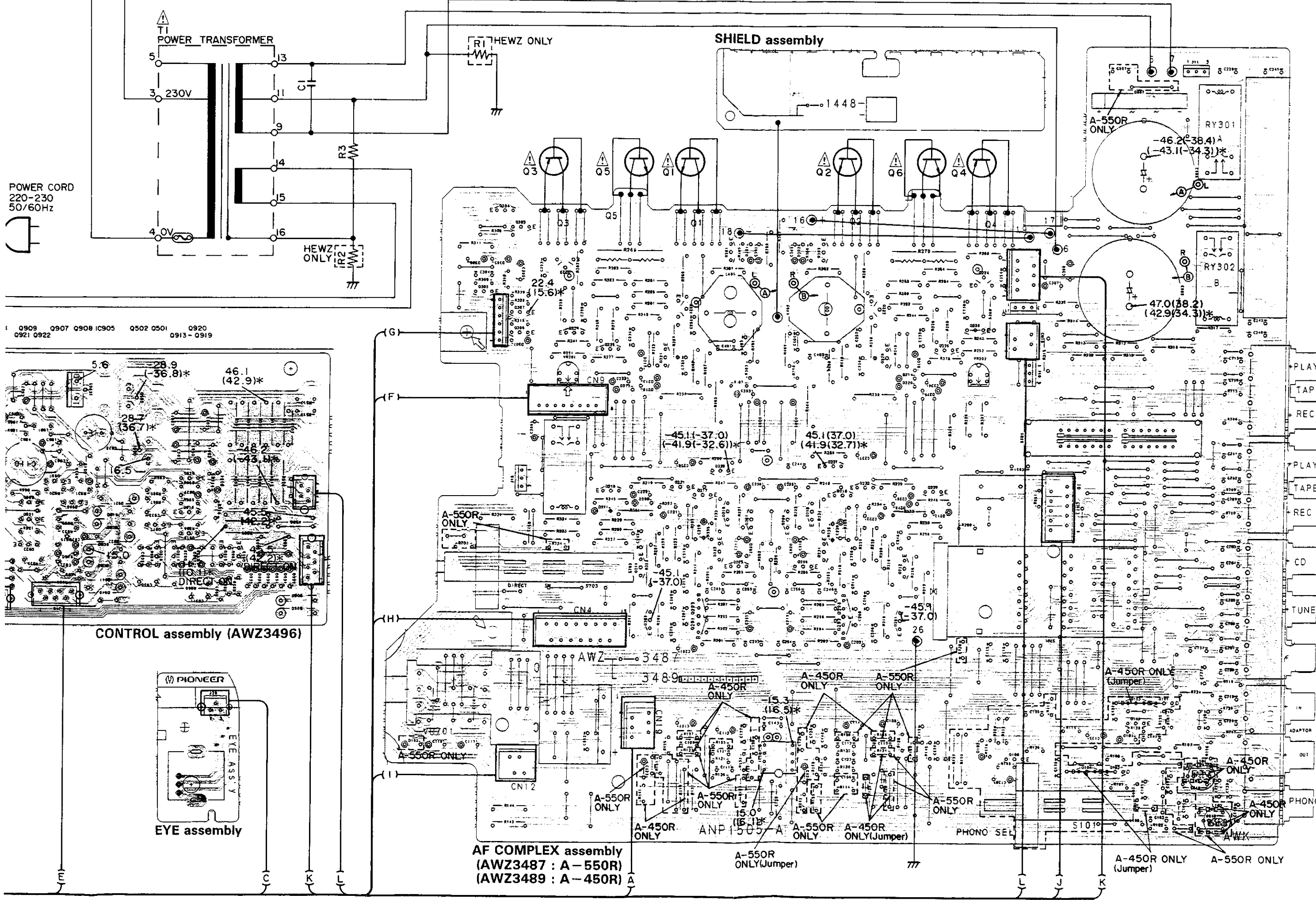

POWER CORD  
220-230  
50/60Hz

Q909 Q907 Q908 IC905 Q502 Q501 Q920  
Q921 Q922 Q913 - Q919

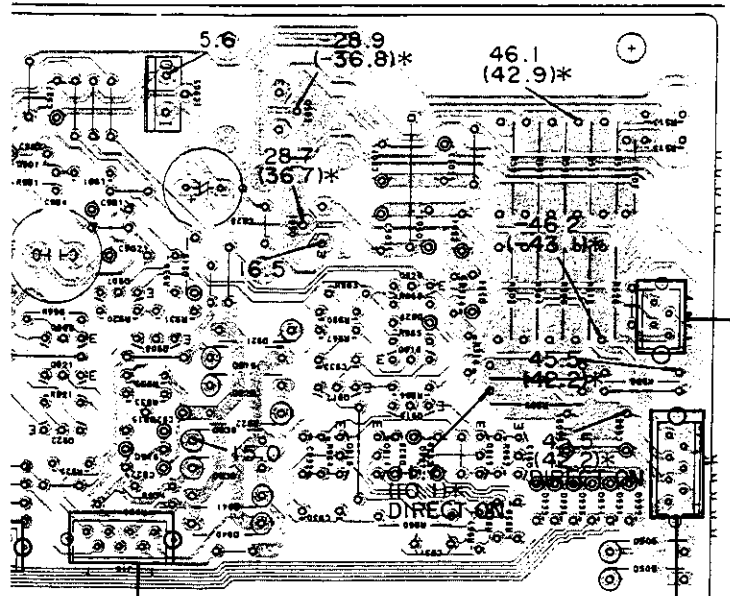

**CONTROL assembly (AWZ3496)**

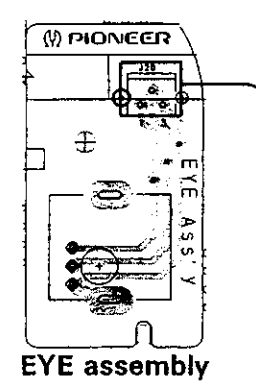

**EYE assembly**

**AF COMPLEX assembly**  
(AWZ3487 : A-550R)  
(AWZ3489 : A-450R)

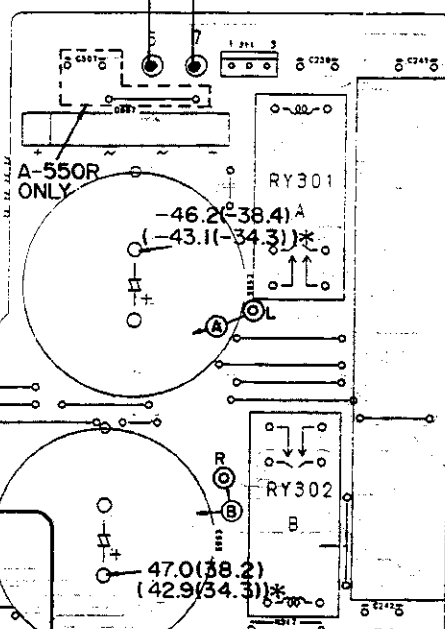

**SHIELD assembly**

Q5 Q6 Q4  
Q5 Q1 Q2  
Q304  
Q303  
Q301 Q302  
Q223 Q224  
Q305  
Q221 Q222 Q307  
Q229 Q230 Q306  
Q225 Q226  
Q227 Q228

VR201  
VR202

Q237  
Q238  
Q231 Q232  
Q219 Q220 Q215  
Q218  
Q208  
Q207

Q233  
Q234  
Q205  
Q206  
Q212  
Q211  
Q293 Q294  
Q291 Q292  
Q203 Q204

Q103  
Q101  
Q105

Q106  
Q104  
Q102

PLAY  
TAPE 2  
REC  
PLAY  
TAPE 1  
REC  
CD  
TUNER  
IN  
ADAPTOR  
OUT  
PHONO

A  
B  
C  
D

Figures enclosed in ( ) \* for A-450R TYPE.

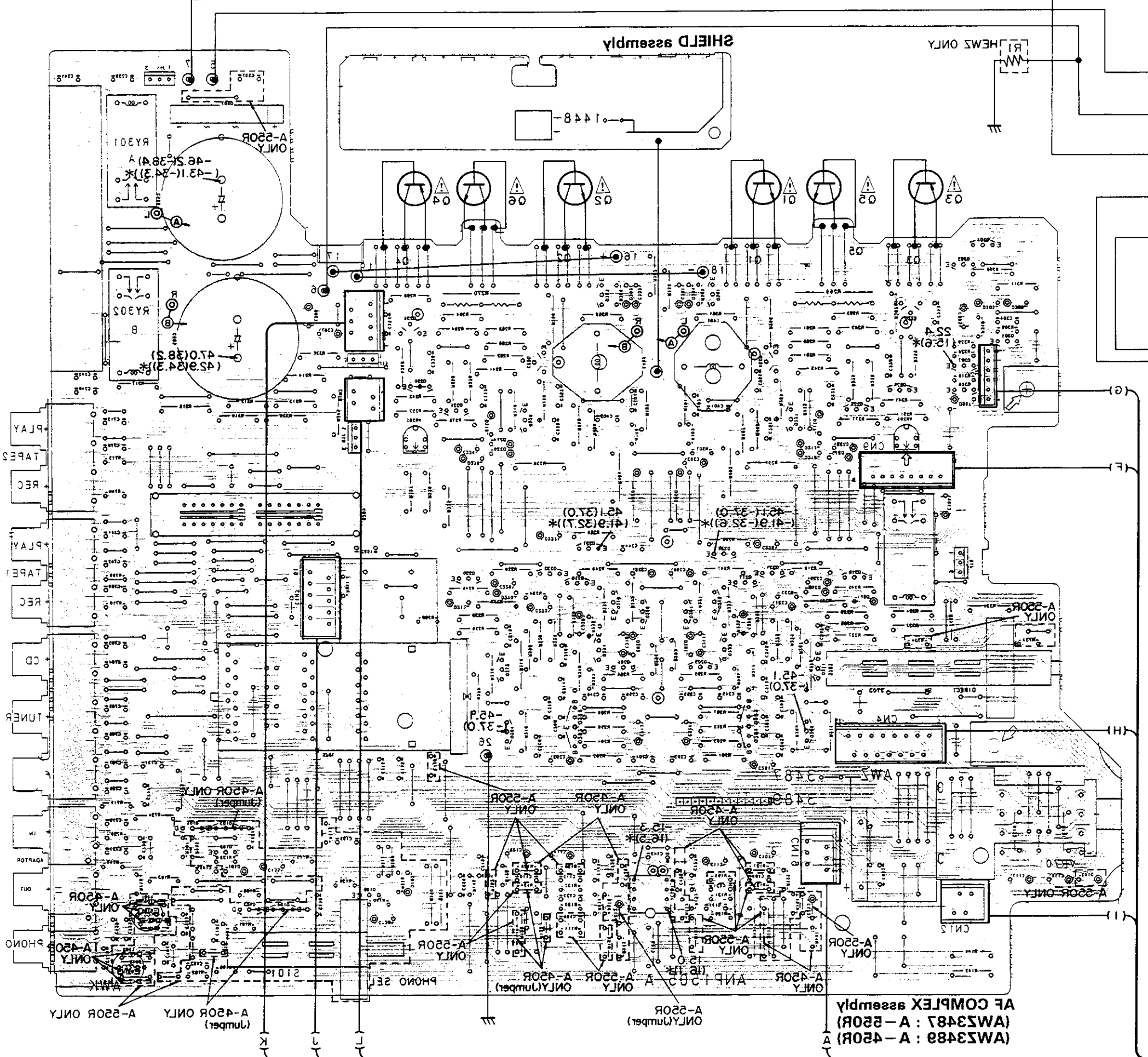
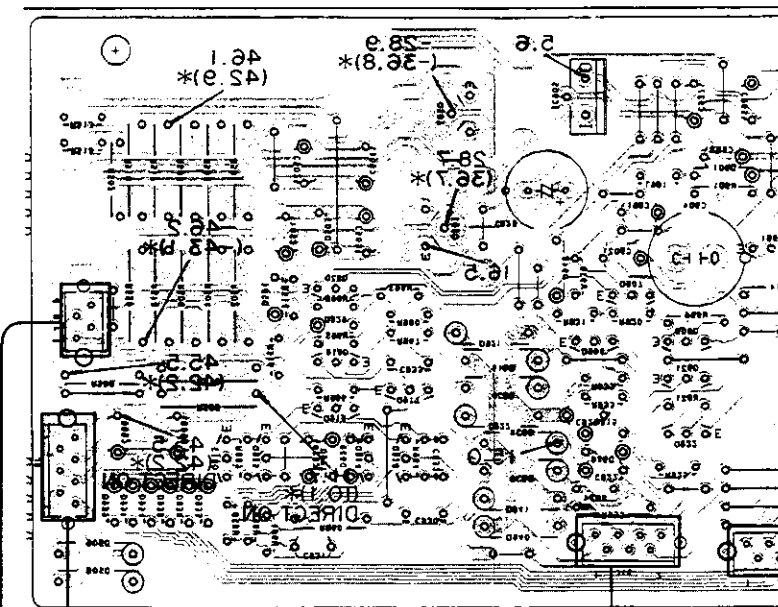
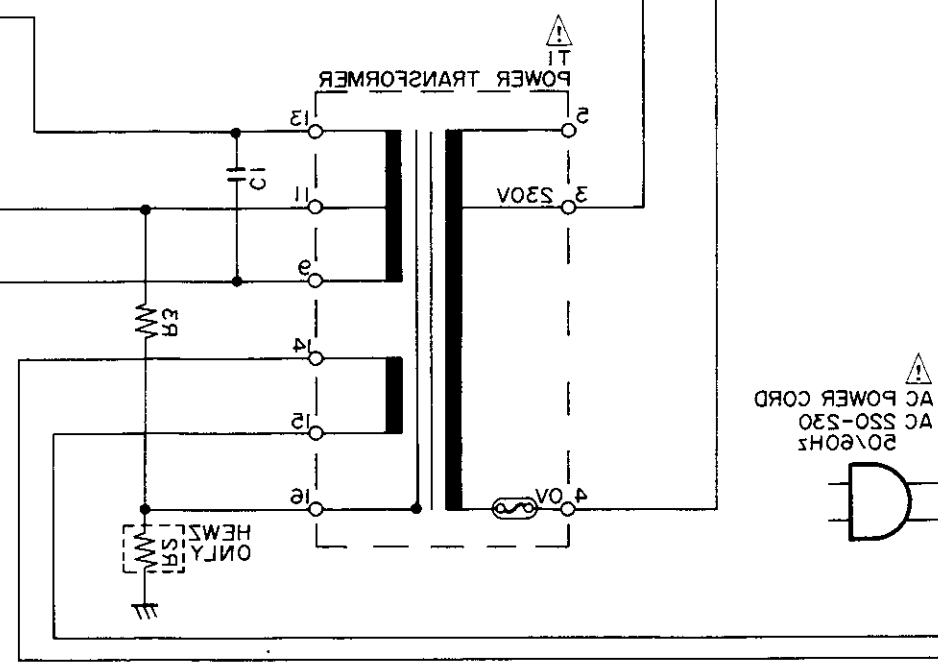

A

B

C

D

17

- 02 02
- 02 01
- 02 04
- 0304
- 0302
- 0303
- 0301
- 0305
- 0307
- 0308
- 0309
- 0310
- 0311
- 0312
- 0313
- 0314
- 0315
- 0316
- 0317
- 0318
- 0319
- 0320
- 0321
- 0322
- 0323
- 0324
- 0325
- 0326
- 0327
- 0328
- 0329
- 0330
- 0331
- 0332
- 0333
- 0334
- 0335
- 0336
- 0337
- 0338
- 0339
- 0340
- 0341
- 0342
- 0343
- 0344
- 0345
- 0346
- 0347
- 0348
- 0349
- 0350
- 0351
- 0352
- 0353
- 0354
- 0355
- 0356
- 0357
- 0358
- 0359
- 0360
- 0361
- 0362
- 0363
- 0364
- 0365
- 0366
- 0367
- 0368
- 0369
- 0370
- 0371
- 0372
- 0373
- 0374
- 0375
- 0376
- 0377
- 0378
- 0379
- 0380
- 0381
- 0382
- 0383
- 0384
- 0385
- 0386
- 0387
- 0388
- 0389
- 0390
- 0391
- 0392
- 0393
- 0394
- 0395
- 0396
- 0397
- 0398
- 0399
- 0400

15

11

10

9

8

7

6

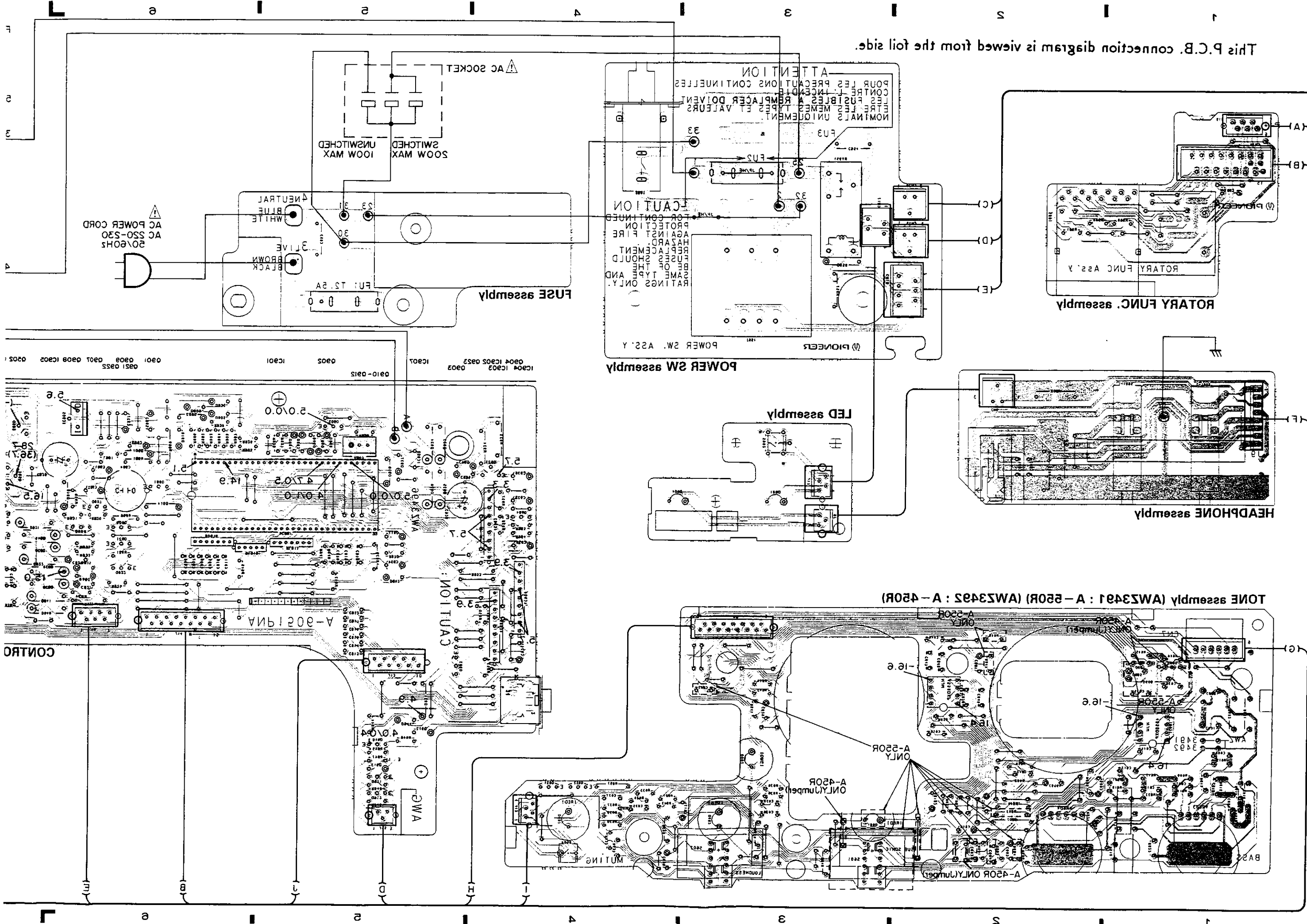

This P.C.B. connection diagram is viewed from the foil side.

ATTENTION  
 POUR LES PRECAUTIONS CONTINUELLES  
 CONTRE L'INCENDIE  
 LES FUSIBLES A REMPLACER DOIVENT  
 ETRE LES MEMES TYPES ET VALEURS  
 NOMINALES UNIFORMES.

CAUTION  
 FOR CONTINUED  
 PROTECTION  
 AGAINST FIRE  
 HAZARD  
 REPLACEMENT  
 FUSES SHOULD  
 BE OF THE  
 SAME TYPE AND  
 RATINGS ONLY.

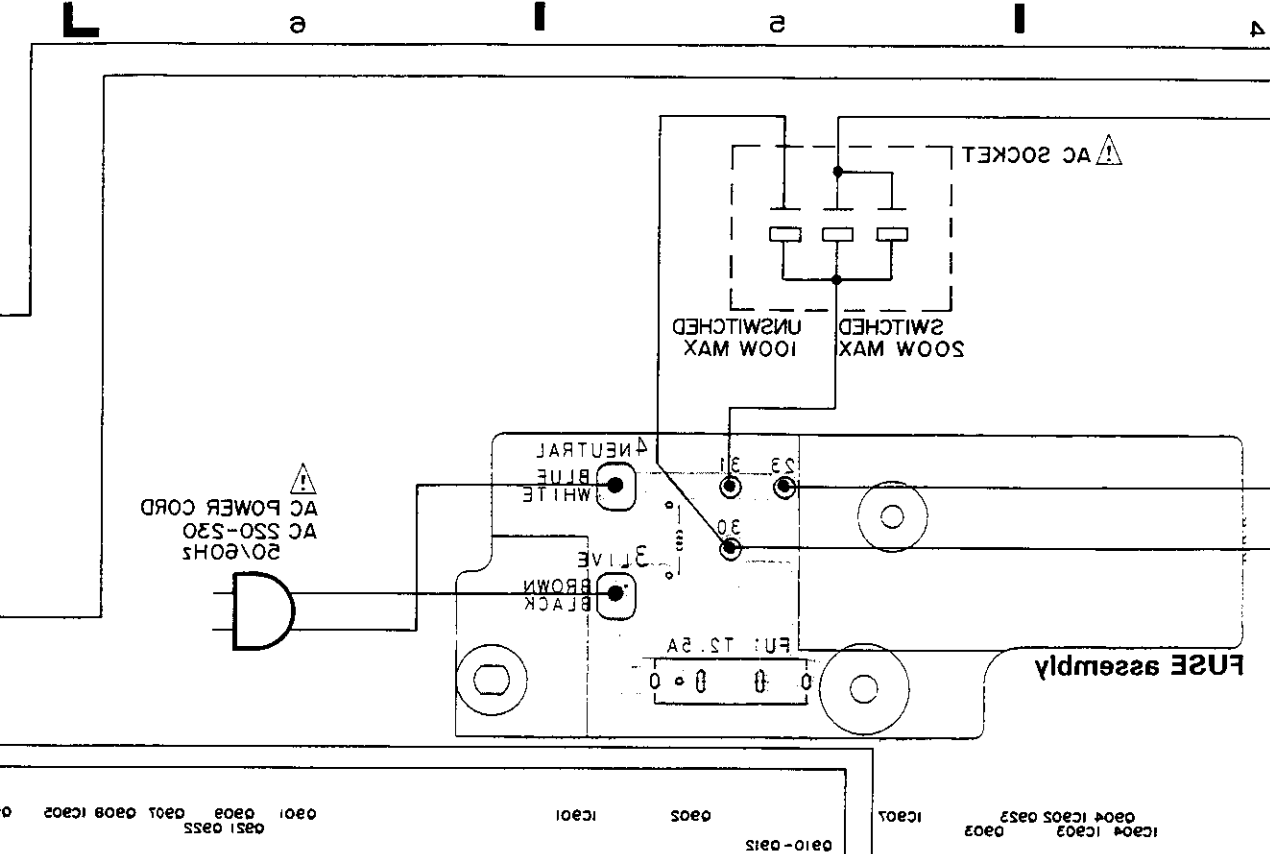
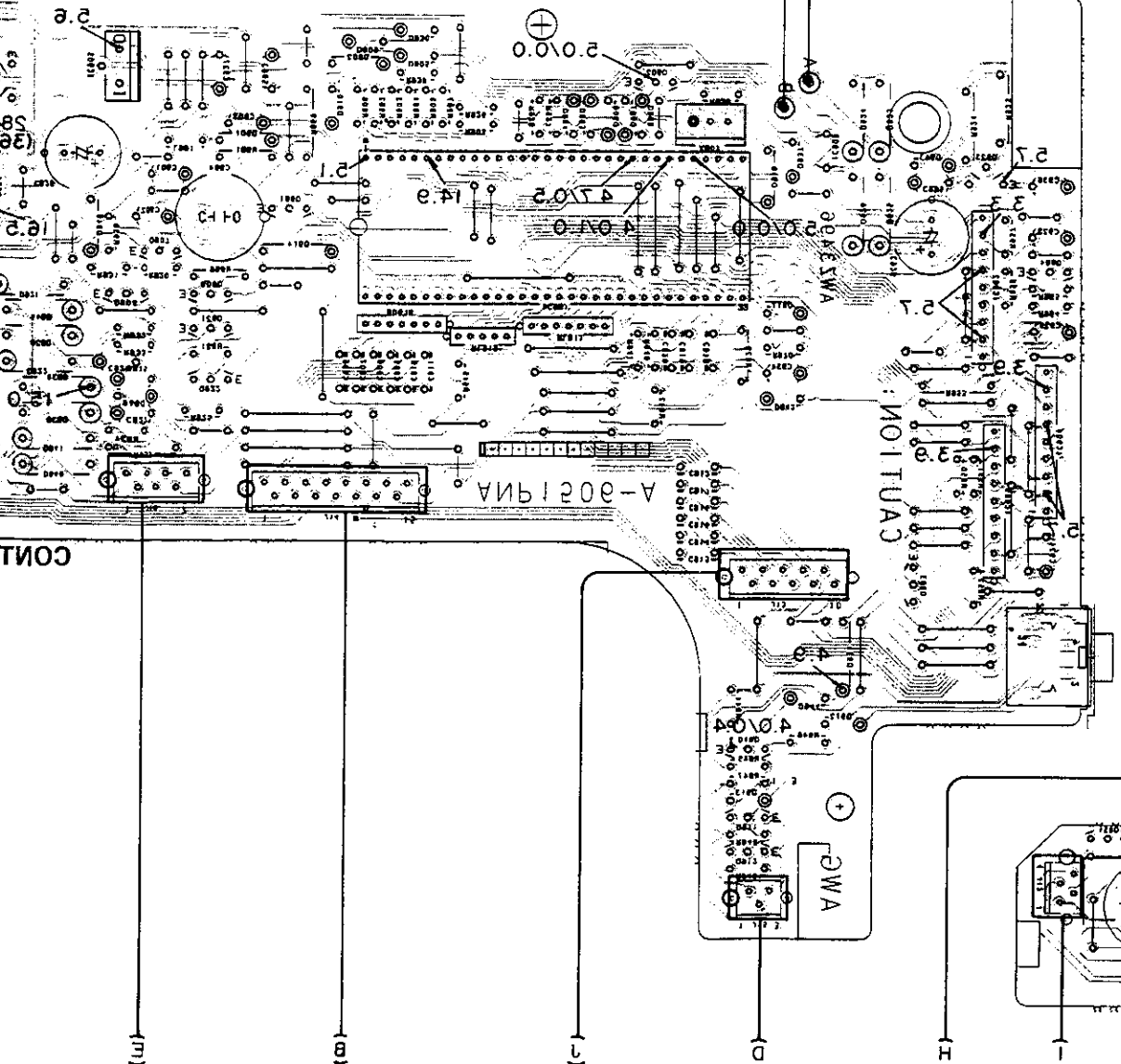
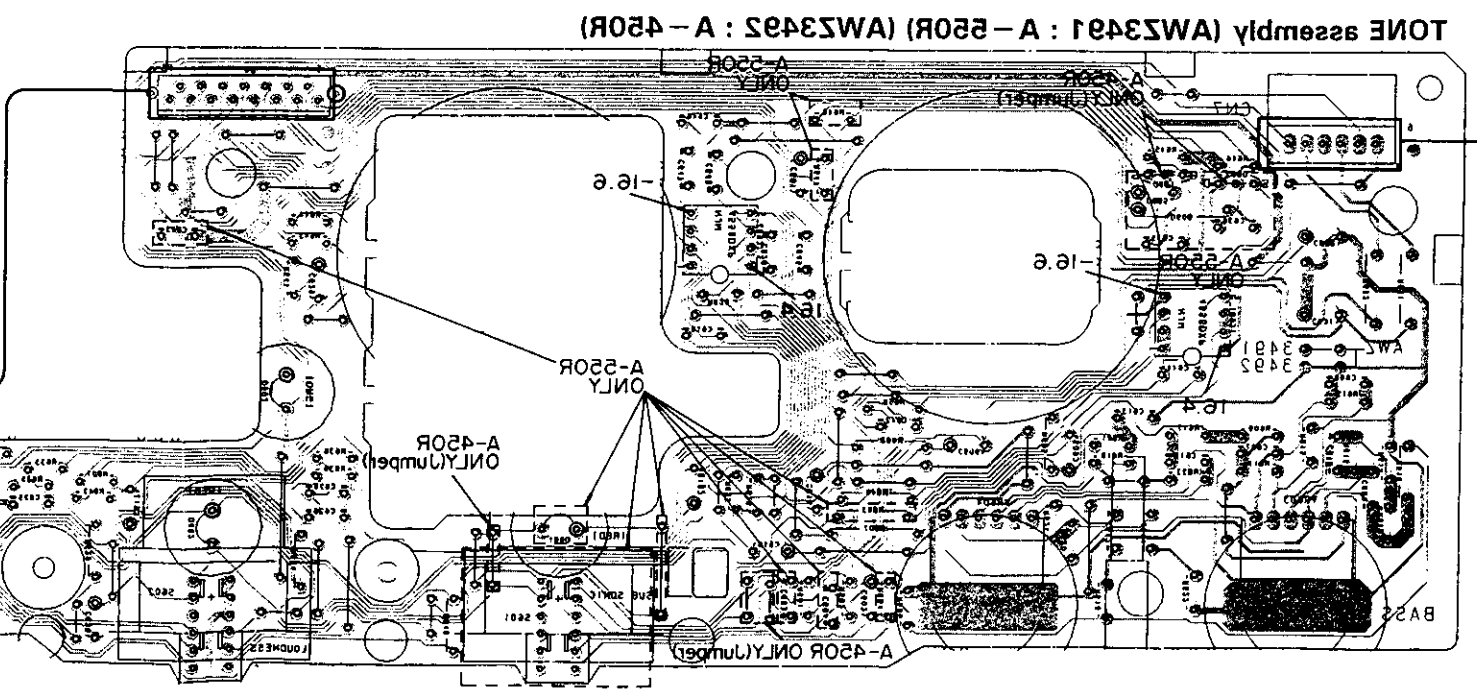
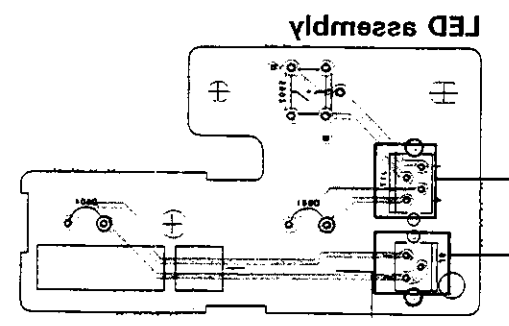
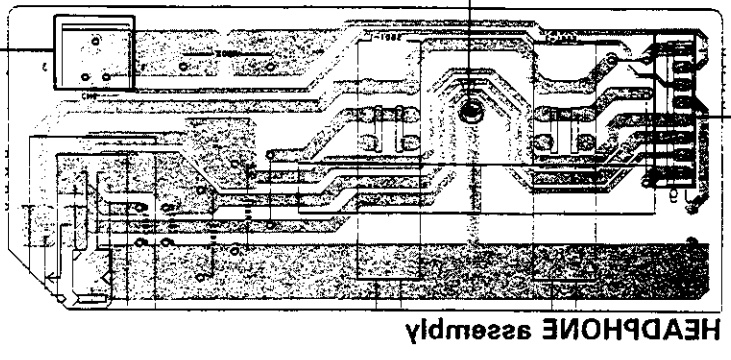
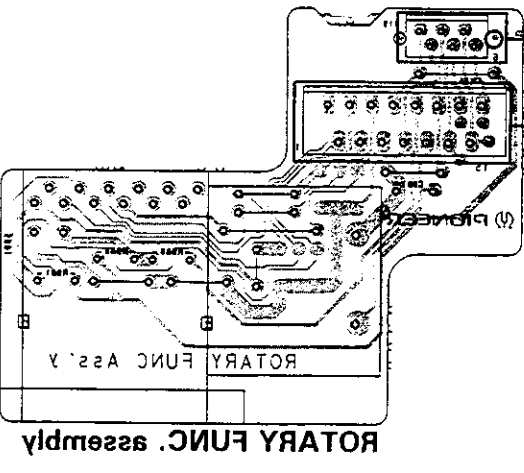



## 4. PCB's PARTS LIST

**NOTES:**

- Part without part number cannot be supplied.
- Parts marked by "●" are not always kept in stock. Their delivery time may be longer than usual or they may be unavailable.
- The  $\Delta$  mark found on some component parts indicates the importance of the safety factor of the part. Therefore, when replacing, be sure to use parts of identical designation.
- When ordering resistors, first convert resistance values into code form as shown in the following examples.

Ex. 1 When there are 2 effective digits (any digit apart from 0), such as 560 ohm and 47k ohm (tolerance is shown by J = 5%, and K = 10%).

560 $\Omega$	56 $\times 10^1$	561.....	RD1/8PM	5	6	1	J
47k $\Omega$	47 $\times 10^3$	473.....	RD1/4PS	4	7	3	J
0.5 $\Omega$	0R5.....		RN2H	0	5		K
1 $\Omega$	010.....		RS1P	0	1	0	K

Ex. 2 When there are 3 effective digits (such as in high precision metal film resistors).

5.62k $\Omega$	562 $\times 10^1$	5621.....	RN1/4SR	5	6	2	1	F
----------------	-------------------	-----------	---------	---	---	---	---	---

Mark No.	Description	Parts No.	Mark No.	Description	Parts No.
<b>POWER SW ASSEMBLY</b>			<b>● CONTROL ASSEMBLY (AWZ3496)</b>		
<b>SEMICONDUCTOR</b>			<b>SEMICONDUCTOR</b>		
D956	DIODE	1SS252	IC901	SYSTEM CONTROL $\mu$ -COM	PD5165A
<b>RELAY &amp; SWITCH</b>			IC902-904	MECHANISM DRIVER IC	TA7291S
$\Delta$ RY951	RELAY	ASR1036	IC905	REGULATOR IC	NJM78M56FAS
$\Delta$ S501	PUSH SWITCH	ASG1035	IC907	IC PROTECTOR	ICP-N38
<b>TORANSFORMER</b>			Q501	TRANSISTOR	2SC3298
$\Delta$ T951	POWER TRANSFORMER	ATT1015	Q502	TRANSISTOR	2SA1306
<b>CAPACITOR</b>			Q901	TRANSISTOR	DTC143ES
$\Delta$ C954	CKA (0.01/AC400V)	ACG1002	Q902-904	TRANSISTOR	DTC124ES
<b>RESISTOR</b>			Q907	TRANSISTOR	2SA1048
R957	CARBON FILM RESISTOR	RD1/2PM270J	Q908	TRANSISTOR	2SC2458
<b>OTHERS</b>			Q909	TRANSISTOR	DTC143ES
CN15	CONNECTOR (3P)	KPE3	Q910-912	TRANSISTOR	2SC2458
CN16	CONNECTOR (7P)	KPE7	Q913	TRANSISTOR	DTC124ES
CN17	CONNECTOR (4P)	KPE4	Q914-919	TRANSISTOR	2SC2458
CN20	CONNECTOR (3P)	KPE3	Q920	TRANSISTOR	DTC124ES
<b>LED ASSEMBLY</b>			Q921, 922	TRANSISTOR	DTC143ES
<b>SEMICONDUCTORS</b>			Q923	TRANSISTOR	2SD1913
D604, 981	LED (RED)	AEL1065	D503, 504	ZENER DIODE	RD18ESB1
<b>SWITCH</b>			D505, 506	DIODE	11E2
S902	SWITCH	ASG1038	D901-914	DIODE	1SS252
			D915	ZENER DIODE	RD6.2ESB
			D916-918	DIODE	1SS252
			D919-926	DIODE	S5566
			D927-937	DIODE	1SS252
			D938-941	DIODE	S5566
			D942	DIODE	1SS252
			D943	ZENER DIODE	RD6.2ESB
			D944, 949	DIODE	1SS252
			<b>COIL</b>		
			L901	AXIAL INDUCTOR	LAU220K

# A-550R, A-450R

Mark No.	Description	Parts No.
<b>CAPACITORS</b>		
C501, 502	ELECTR.CAPACITOR	CEAS100M50
C503, 504	ELECTR.CAPACITOR	CEAS470M50
C508	ELECTR.CAPACITOR	CEAS470M50
C509	ELECTR.CAPACITOR	CEAS220M50
C901	ELECTR.CAPACITOR	CEAS470M16
C902	CERAMIC CAPACITOR	CKCYF103Z50
C903	ELECTR.CAPACITOR	CEAS470M16
C904	CEA (47000/5.5V)	ACH1037
C905	ELECTR.CAPACITOR	CEAS2R2M50
C906-920	CERAMIC CAPACITOR	CKMYB271K50
C921	ELECTR.CAPACITOR	CEAS100M50
C922	ELECTR.CAPACITOR	CEAS101M25
C923-925	ELECTR.CAPACITOR	CEAS470M25
C926	ELECTROLYTIC CAPACIT	CEAS471M25
C927	ELECTR.CAPACITOR	CEAS470M10
C928	ELECTROLYTIC CAPACIT	CEAS471M25
C929	ELECTR.CAPACITOR	CEAS0R1M50
C930	CERAMIC CAPACITOR	CCCSL101J50
C931	ELECTR.CAPACITOR	CEANP4R7M35
C932, 933	CERAMIC CAPACITOR	CCCSL101J50
C934	ELECTR.CAPACITOR	CEAS4R7M50
C935	ELECTR.CAPACITOR	CEAS470M25
C936	ELECTR.CAPACITOR	CEAS100M50
<b>RESISTORS</b>		
R501, 502	METAL OXIDE RESISTOR	RS1PMF121J
R503, 504	METAL OXIDE RESISTOR	RS1LMF121J
R505, 506	METAL OXIDE RESISTOR	RS1PMF121J
△ R507, 508	CARBON FILM RESISTOR	RD1/4PMF010J
△ R509, 510	METAL OXIDE RESISTOR	RS1LMF562J
R517-520	METAL OXIDE RESISTOR	RS1PMF101J
R909	RESISTOR ARRAY (100K)	RA6T104J
R910	RESISTOR ARRAY (10K)	RA4T104J
R911	RESISTOR ARRAY (100K)	RA6T104J
△ R923	FUSIBLE RESISTOR	RFA1/4PS4R7J
R924	CARBON FILM RESISTOR	RD1/4PM102J
R935	CARBON FILM RESISTOR	RD1/4PM222J
R960	CARBON FILM RESISTOR	RD1/4PM472J
	Other resistors	RD1/4PM□□□J
<b>OTHERS</b>		
	JACK	AKN1006

Mark No.	Description	Parts No.
<b>ROTARY FUNC. ASSEMBLY</b>		
<b>SWITCH</b>		
S901	SWITCH	ASD1016
<b>CAPACITOR</b>		
C981	CERAMIC CAPACITOR	CKDYF103Z50
<b>RESISTORS</b>		
	All resistors	RD1/8PM□□□J
<b>OTHERS</b>		
X901	CERAMIC RESONATOR	ASS1018
CN14	CONNECTOR (15P)	KPE15
<b>EYE ASSEMBLY</b>		
<b>OTHERS</b>		
	REMOTE RECEIVER UNIT	AXX1010
<b>SHIELD ASSEMBLY</b>		
No parts ake supplied with the SHIELD assembly.		
<b>HEAD PHONE ASSEMBLY</b>		
<b>SWICH</b>		
S801	PUSH SWITCH	SUL5L2B2S
<b>CAPACITORS</b>		
C801, 802	CERAMIC CAPACITOR	CKCYB392K50
<b>RESISTORS</b>		
△ R801, 802	METAL OXIDE RESISTOR	RS1PMF331J
△ R803	METAL OXIDE RESISTOR	RS1LMF681J
<b>OTHERS</b>		
CN6	JACK CONNECTOR (3P)	AKN1002 KPE3
<b>◎ AF COMPLEX ASSEMBLY (AWZ3487) (FOR A - 550R AND A - 550R - S)</b>		
<b>SEMICONDUCTORS</b>		
IC101	IC	UPC4570C
Q101-104	N-FET	2SK369
Q105, 106	TRANSISTOR	2SC2458
Q203-208	TRANSISTOR	2SA1048



Mark No.	Description	Parts No.	Mark No.	Description	Parts No.
Q211, 212	TRANSISTOR	2SC1845	C115, 116	MYLOR FILM CAPACITOR	CQMA392K50
Q215-218	TRANSISTOR	2SA1048	C117, 118	ELECTROLYTIC CAPACIT	CEXA221M25
Q219, 220	TRANSISTOR	2SC2705	C119, 120	CERAMIC CAPACITOR	CKCYF103Z50
Q221, 222	TRANSISTOR	2SC3298	C121, 122	MYLOR FILM CAPACITOR	CQMA122J50
Q223, 224	TRANSISTOR	2SA1306	C127, 128	CERAMIC CAPACITOR	CCCSL101J50
Q225, 226	TRANSISTOR	2SC2603	C129	CERAMIC CAPACITOR	CKPYX103N25
Q227, 228	TRANSISTOR	2SC1845	C135, 136	ELECTR.CAPACITOR	CEAS470M10
Q229, 230	TRANSISTOR	2SA992	C137, 138	CERAMIC CAPACITOR	CCCSL151J50
Q231, 232	TRANSISTOR	2SA1145	C139, 140	CERAMIC CAPACITOR	CCCSL330J50
Q233, 234	TRANSISTOR	2SA992	C141	CERAMIC CAPACITOR	CKCYF103Z50
Q237	TRANSISTOR	2SC1845	C201, 202	ELECTROLYTIC CAPACIT	CEEA2R2M50
Q238	TRANSISTOR	2SA992	C203,204	CERAMIC CAPACITOR	CCCSL101K500
Q291-294	TRANSISTOR	2SA992	C205, 206	CERAMIC CAPACITOR	CCCSL101J50
Q301, 302	TRANSISTOR	2SC1845	C207, 208	CERAMIC CAPACITOR	CCCSL470J50
Q303, 304	TRANSISTOR	2SC2458	C209, 210	CERAMIC CAPACITOR	CCCSL181J50
Q305	TRANSISTOR	2SA1048	C211, 212	ELECTROLYTIC CAPACIT	CEEA221M16
Q306	TRANSISTOR	2SC1815	C213-216	CERAMIC CAPACITOR	CCCSL120K500
Q307	TRANSISTOR	2SC2458	C217, 218	ELECTR.CAPACITOR	CEAS101M10
D101, 102	ZENER DIODE	RD7.5ESB2	C219-222	ELECTR.CAPACITOR	CEAS3R3M100
D103	DIODE	1SS252	C225, 226	ELECTR.CAPACITOR	CEAS331M10
D201, 202	ZENER DIODE	RD2.7ESB1	C227-230	CERAMIC CAPACITOR	CCCSL330K500
D209-216	DIODE	1SS252	C231, 232	CERAMIC CAPACITOR	CKCYB122K50
D217-220	ZENER DIODE	RD15ESB	C233-236	ELECTR.CAPACITOR	CEAS100M50
D301-306	DIODE	1SS252	C237, 238	ELECTR.CAPACITOR	CEAS101M50
D307	ZENER DIODE	RD22ESB	C239-242	POLYESTER CAPACITOR	CQMXA472J100
D507	DIODE	D5SB20F	C244	CERAMIC CAPACITOR	CKDYX104M25
<b>RELAIIES &amp; SWITCHES</b>			C245, 246	CERAMIC CAPACITOR	CKCYB331K50
RY301, 302	RELAY	ASR1037	C247, 248	AUDIO FILM CAPACITOR	CFTXA103J50
RY303	RELAY	ASR1038	C251-254	CERAMIC CAPACITOR	CCCSL680K500
S101	PUSH SWITCH	ASG1012	C255	CERAMIC CAPACITOR	CCCSL680J50
S701	SWITCH	ASD1017	C256	CERAMIC CAPACITOR	CCDSL470J50
S702	SWITCH	ASU1002	C301,302	ELECTR.CAPACITOR	CEANP2R2M50
S703	PUSH SWITCH	SULL6S	C303	ELECTROLYTIC CAPACIT	CEAS471M6
<b>COILS</b>			C304	CERAMIC CAPACITOR	CKCYF103Z50
L101, 102	COIL	ATH1010	C305	ELECTR.CAPACITOR	CEAS101M25
L107, 108	AXIAL INDUCTOR	LAU3R3K	C306-308	ELECTR.CAPACITOR	CEASR47M50
L401, 402	COIL	ATH1009	C401-404	AUDIO FILM CAPACITOR	CFTXA104J50
<b>CAPACITORS</b>			C505	ELECTROLYTIC CAPACIT	ACH1196
C101, 102	AUDIO FILM CAPACITOR	CFTXA103J50	C506	ELECTROLYTIC CAPACIT	ACH1078
C103, 104	CERAMIC CAPACITOR	CCCSL271J50	C507	MYLOR FILM CAPACITOR	CQMA103K250
C105, 106	CERAMIC CAPACITOR	CKCYB472K50	C703-708	CERAMIC CAPACITOR	CCCSL271J50
C107, 108	ELECTROLYTIC CAPACIT	CEXA101M25	C711, 712	CERAMIC CAPACITOR	CCCSL271J50
C109, 110	AUDIO FILM CAPACITOR	CFTXA683J50	C715, 716	CERAMIC CAPACITOR	CCCSL271J50
C111, 112	AUDIO FILM CAPACITOR	CFTXA183J50	C719, 720	CERAMIC CAPACITOR	CCCSL271J50
C113, 114	ELECTR.CAPACITOR	CEANP220M10			

# A-550R, A-450R

Mark No.	Description	Parts No.	Mark No.	Description	Parts No.
C725	CERAMIC CAPACITOR	CCDSL221J50	R251, 252	CARBON FILM RESISTOR	RD1/4PM103J
C726	CERAMIC CAPACITOR	CKCYF103Z50	R255, 256	CARBON FILM RESISTOR	RD1/4PM561J
C727, 728	CERAMIC CAPACITOR	CCCSL221J50	△ R257-260	FUSIBLE RESISTOR	RFA1/4PS101J
C731	CERAMIC CAPACITOR	CKCYF103Z50	△ R261-264	FUSIBLE RESISTOR	RFA1/4PS470J
C851, 852	CERAMIC CAPACITOR	CKDYF103Z50	△ R265-268	FUSIBLE RESISTOR	RFA1/4PS4R7J
<b>RESISTORS</b>			△ R269, 270	RESISTOR (0.33, 5W)	ACN1063
VR201, 202	VR	ACP1045	△ R275, 276	CARBON FILM RESISTOR	RD1/4PM472J
VR701	VARIABLE RESISTOR	ACX1060	R277, 278	CARBON FILM RESISTOR	RD1/4PM222J
R101, 102	CARBON FILM RESISTOR	RDR1/6PU101J	△ R281-284	FUSIBLE RESISTOR	RFA1/4PS331J
R107, 108	CARBON FILM RESISTOR	RDR1/6PU563J	△ R285, 286	FUSIBLE RESISTOR	RFA1/4PS101J
R119, 120	CARBON FILM RESISTOR	RDR1/4PM6R8J	△ R287, 288	CARBON FILM RESISTOR	RD1/4PMF4R7J
R121, 122	CARBON FILM RESISTOR	RDR1/4PM820J	△ R289, 290	FUSIBLE RESISTOR	RFA1/4PS101J
R133, 134	CARBON FILM RESISTOR	RDR1/6PU391J	△ R301, 302	CARBON FILM RESISTOR	RD1/4PMF222J
R143, 144	CARBON FILM RESISTOR	RD1/4PM560J	△ R308	CARBON FILM RESISTOR	RD1/4PMF101J
R201, 202	CARBON FILM RESISTOR	RDR1/4PM221J	R311	CARBON FILM RESISTOR	RD1/4PM101J
R203, 204	CARBON FILM RESISTOR	RDR1/4PM104J	R312	CARBON FILM RESISTOR	RD1/4PM221J
R205, 206	CARBON FILM RESISTOR	RD1/4PM152J	R313-315	CARBON FILM RESISTOR	RD1/4PM181J
R207, 208	CARBON FILM RESISTOR	RD1/4PM103J	R317	CARBON FILM RESISTOR	RD1/4PM221J
R209, 210	CARBON FILM RESISTOR	RD1/4PM561J	R318-320	CARBON FILM RESISTOR	RD1/4PM181J
R211, 212	CARBON FILM RESISTOR	RD1/4PM562J	R321	CARBON FILM RESISTOR	RD1/4PM221J
R213, 214	CARBON FILM RESISTOR	RD1/4PM562J	R322-324	CARBON FILM RESISTOR	RD1/4PM181J
R215, 216	CARBON FILM RESISTOR	RDR1/4PM821J	R325-327	CARBON FILM RESISTOR	RD1/4PM221J
R217, 218	CARBON FILM RESISTOR	RDR1/4PM124J	△ R330	CARBON FILM RESISTOR	RD1/4PMF010J
R219, 220	CARBON FILM RESISTOR	RD1/4PM473J	△ R401, 402	CARBON FILM RESISTOR	RD1/4PMFL101J
R221, 222	CARBON FILM RESISTOR	RD1/4PM101J	△ R403, 404	METAL OXIDE RESISTOR	RS1LMF331J
R223-226	CARBON FILM RESISTOR	RD1/4PM392J	△ R407, 408	CARBON FILM RESISTOR	RD1/4PMFL100J
R227, 228	CARBON FILM RESISTOR	RD1/4PM561J	R731, 732	CARBON FILM RESISTOR	RD1/4PM103J
R229-232	CARBON FILM RESISTOR	RD1/4PM392J	Other resistors		RD1/8PM□□□J
R233, 234	CARBON FILM RESISTOR	RD1/4PM101J	<b>OTHERS</b>		
R237, 238	CARBON FILM RESISTOR	RDR1/4PM224J	PIN JACK (4P)		AKB1007
△ R239-242	FUSIBLE RESISTOR	RFA1/4PS101J	PIN JACK (6P)		AKB1008
△ R243, 244	CARBON FILM RESISTOR	RD1/4PMF561J	PIN JACK (6P)		AKB1024
△ R245-248	FUSIBLE RESISTOR	RFA1/4PS101J	SPEAKER TERMINAL		AKE1011
R249, 250	CARBON FILM RESISTOR	RD1/4PM122J	8-P		

Mark No.	Description	Parts No.
CN10	CONNECTOR (4P)	KPE4
CN12	CONNECTOR (4P)	KPE4
CN13	CONNECTOR (10P)	KPE10
CN19	CONNECTOR (6P)	KPE6
CN4	CONNECTOR (15P)	KPE15
CN8	CONNECTOR (7P)	KPE7
CN9	JUMPER CONNECTOR	KPC8

**● AF COMPLEX ASSEMBLY (AWZ3489)  
(FOR A - 450R)**

**SEMICONDUCTORS**

IC101	OP - AMP - IC	M5220P
Q203-208	TRANSISTOR	2SA1048
Q211, 212	TRANSISTOR	2SC1845
Q215-218	TRANSISTOR	2SA1048
Q219, 220	TRANSISTOR	2SC2705
Q221, 222	TRANSISTOR	2SC3298
Q223, 224	TRANSISTOR	2SA1306
Q225, 226	TRANSISTOR	2SC2603
Q227, 228	TRANSISTOR	2SC1845
Q229, 230	TRANSISTOR	2SA992
Q231, 232	TRANSISTOR	2SA1145
Q233, 234	TRANSISTOR	2SA992
Q237	TRANSISTOR	2SC1845
Q238	TRANSISTOR	2SA992
Q291-294	TRANSISTOR	2SA992
Q301, 302	TRANSISTOR	2SC1845
Q303, 304	TRANSISTOR	2SC2458
Q305	TRANSISTOR	2SA1048
Q306	TRANSISTOR	2SC1815
Q307	TRANSISTOR	2SC2458
D201, 202	ZENER DIODE	RD2.7ESB1
D209-216	DIODE	1SS252
D217-220	ZENER DIODE	RD8.2ESB1
D301-306	DIODE	1SS252
D307	ZENER DIODE	RD15ESB
D507	DIODE	D5SB20F

**SWITCHES & RELAIIES**

RY301-303	RELAY	ASR1038
S701	SWITCH	ASD1017
S702	SWITCH	ASU1002
S703	PUSH SWITCH	SULL6S

**COILS**

L103-106	AXIAL INDUCTOR	LAU221K
L401, 402	COIL	ATH1009

**CAPACITORS**

C103, 104	CERAMIC CAPACITOR	CCCSL330J50
C107, 108	ELECTR.CAPACITOR	CEAS101M10
C109, 110	AUDIO FILM CAPACITOR	CFTXA683J50
C111, 112	AUDIO FILM CAPACITOR	CFTXA183J50

Mark No.	Description	Parts No.
C113, 114	ELECTR.CAPACITOR	CEAS4R7M50
C115, 116	MYLOR FILM CAPACITOR	CQMA392K50
C117, 118	ELECTR.CAPACITOR	CEAS221M25
C119, 120	CERAMIC CAPACITOR	CKCYF103Z50
C121, 122	MYLOR FILM CAPACITOR	CQMA122J50
C123, 124	ELECTR.CAPACITOR	CEAS100M50
C125, 126	CERAMIC CAPACITOR	CCCSL101J50
C127, 128	CERAMIC CAPACITOR	CCDSL221J50
C129	CERAMIC CAPACITOR	CKPYX103N25
C139, 140	CERAMIC CAPACITOR	CCDSL330J50
C141	CERAMIC CAPACITOR	CKCYF103Z50
C201, 202	ELECTROLYTIC CAPACIT	CEEA2R2M50
C203, 204	CERAMIC CAPACITOR	CCCSL101K500
C205, 206	CERAMIC CAPACITOR	CCCSL101J50
C207, 208	CERAMIC CAPACITOR	CCCSL470J50
C209, 210	CERAMIC CAPACITOR	CCCSL181J50
C211, 212	ELECTROLYTIC CAPACIT	CEEA221M16
C213-216	CERAMIC CAPACITOR	CCCSL120K500
C217, 218	ELECTR.CAPACITOR	CEAS101M10
C219-222	ELECTR.CAPACITOR	CEAS3R3M100
C225, 226	ELECTR.CAPACITOR	CEAS331M10
C227-230	CERAMIC CAPACITOR	CCCSL330K500
C231, 232	CERAMIC CAPACITOR	CKCYB122K50
C233-236	ELECTR.CAPACITOR	CEAS100M50
C237, 238	ELECTR.CAPACITOR	CEAS101M50
C239-242	POLYESTER CAPACITOR	CQMXA472J100
C244	MYLOR FILM CAPACITOR	CQMA224K50
C245, 246	CERAMIC CAPACITOR	CKCYB331K50
C247, 248	AUDIO FILM CAPACITOR	CFTXA103J50
C251-254	CERAMIC CAPACITOR	CCCSL680K500
C255	CERAMIC CAPACITOR	CCCSL680J50
C256	CERAMIC CAPACITOR	CCDSL470J50
C301, 302	ELECTR.CAPACITOR	CEANP2R2M50
C303	ELECTROLYTIC CAPACIT	CEAS471M6
C304	CERAMIC CAPACITOR	CKCYF103Z50
C305	ELECTR.CAPACITOR	CEAS101M25
C306-308	ELECTR.CAPACITOR	CEASR47M50
C401-404	AUDIO FILM CAPACITOR	CFTXA104J50
C505	ELECTROLYTIC CAPACIT	ACH1189
C506	ELECTROLYTIC CAPACIT	ACH1190
C703-708	CERAMIC CAPACITOR	CCCSL271J50
C711, 712	CERAMIC CAPACITOR	CCCSL271J50
C715, 716	CERAMIC CAPACITOR	CCCSL271J50
C719, 720	CERAMIC CAPACITOR	CCCSL271J50
C725	CERAMIC CAPACITOR	CCCSL221J50
C727, 728	CERAMIC CAPACITOR	CCCSL221J50

# A-550R, A-450R

Mark No.	Description	Parts No.
C731	CERAMIC CAPACITOR	CKCYF103Z50
C851, 852	CERAMIC CAPACITOR	CKDYF103Z50
<b>RESISTORS</b>		
VR201, 202	VR	ACP1045
VR701	VARIABLE RESISTOR	ACX1060
R121, 122	CARBON FILM RESISTOR	RDR1/4PM820J
R133, 134	CARBON FILM RESISTOR	RDR1/6PU471J
R141, 142	CARBON FILM RESISTOR	RDR1/6PU563J
R143, 144	CARBON FILM RESISTOR	RD1/4PM560J
R201, 202	CARBON FILM RESISTOR	RDR1/4PM221J
R203, 204	CARBON FILM RESISTOR	RDR1/4PM104J
R205, 206	CARBON FILM RESISTOR	RD1/4PM152J
R207, 208	CARBON FILM RESISTOR	RD1/4PM103J
R209, 210	CARBON FILM RESISTOR	RD1/4PM561J
R211-214	CARBON FILM RESISTOR	RD1/4PM562J
R215, 216	CARBON FILM RESISTOR	RDR1/4PM102J
R217, 218	CARBON FILM RESISTOR	RDR1/4PM124J
R219, 220	CARBON FILM RESISTOR	RD1/4PM473J
R221, 222	CARBON FILM RESISTOR	RD1/4PM101J
R223, 224	CARBON FILM RESISTOR	RD1/4PM332J
R225, 226	CARBON FILM RESISTOR	RD1/4PM332J
R227, 228	CARBON FILM RESISTOR	RD1/4PM561J
R229-232	CARBON FILM RESISTOR	RD1/4PM332J
R233, 234	CARBON FILM RESISTOR	RD1/4PM101J
R237, 238	CARBON FILM RESISTOR	RDR1/4PM224J
△ R239-242	FUSIBLE RESISTOR	RFA1/4PS101J
△ R243, 244	CARBON FILM RESISTOR	RD1/4PMF561J
△ R245-248	FUSIBLE RESISTOR	RFA1/4PS101J
R249, 250	CARBON FILM RESISTOR	RD1/4PM122J
R251, 252	CARBON FILM RESISTOR	RD1/4PM103J
R255, 256	CARBON FILM RESISTOR	RD1/4PM561J
△ R257-260	FUSIBLE RESISTOR	RFA1/4PS101J
△ R261-264	FUSIBLE RESISTOR	RFA1/4PS470J

Mark No.	Description	Parts No.
△ R265-268	FUSIBLE RESISTOR	RFA1/4PS4R7J
△ R269, 270	RESISTOR (0.33, 5W)	ACN1063
R275, 276	CARBON FILM RESISTOR	RD1/4PM472J
R277, 278	CARBON FILM RESISTOR	RD1/4PM222J
△ R281-284	FUSIBLE RESISTOR	RFA1/4PS331J
△ R285, 286	FUSIBLE RESISTOR	RFA1/4PS101J
△ R287, 288	FUSIBLE RESISTOR	RFA1/4PS4R7J
△ R289, 290	FUSIBLE RESISTOR	RFA1/4PS101J
△ R301, 302	CARBON FILM RESISTOR	RD1/4PMF222J
△ R308	CARBON FILM RESISTOR	RD1/4PMF101J
R311	CARBON FILM RESISTOR	RD1/4PM101J
R312-315	CARBON FILM RESISTOR	RD1/4PM181J
R317-324	CARBON FILM RESISTOR	RD1/4PM181J
R325-327	CARBON FILM RESISTOR	RD1/4PM221J
△ R330	CARBON FILM RESISTOR	RD1/4PMF010J
△ R401, 402	CARBON FILM RESISTOR	RD1/4PMFL101J
△ R403, 404	METAL OXIDE RESISTOR	RS1LMF331J
△ R407, 408	CARBON FILM RESISTOR	RD1/4PMFL100J
R731, 732	CARBON FILM RESISTOR	RD1/4PM103J
	Other resistors	RD1/8PM□□□J
<b>OTHERS</b>		
	PIN JACK (4P)	AKB1007
	PIN JACK (6P)	AKB1008
	PIN JACK (6P)	AKB1024
	SPEAKER TERMINAL 8-P	AKE1011
CN10, 12	CONNECTOR (4P)	KPE4
CN13	CONNECTOR (10P)	KPE10
CN19	CONNECTOR (6P)	KPE6
CN4	CONNECTOR (15P)	KPE15
CN8	CONNECTOR (7P)	KPE7
CN9	JUMPER CONNECTOR	KPC8

● **TONE ASSEMBLY (AWZ3491)**  
(FOR A - 550R AND A - 550R - S)

**SEMICONDUCTORS**

IC601, 602	OP-AMP IC	RC4558DXP
Q601, 602	N-FET	2SK246
Q851, 852	TRANSISTOR	DTC143ES

Mark No.	Description	Parts No.
D601, 602	LED (RED)	AEL1065
D603	LED	AEL1084
D605, 606	DIODE	ISS252
D607	LED (RED)	AEL1065
<b>SWITCHES</b>		
S601, 602	PUSH SWITCH	ASG1019
S604	SWITCH	ASG1029
<b>CAPACITORS</b>		
C601, 602	ELECTR.CAPACITOR	CEAS010M50
C603, 604	AUDIO FILM CAPACITOR	CFTXA823J50
C605, 606	ELECTR.CAPACITOR	CEAS2R2M50
C607, 608	CERAMIC CAPACITOR	CKDYX153M25
C609, 610	CERAMIC CAPACITOR	CKDYX823M25
C611, 612	CERAMIC CAPACITOR	CKCYB332K50
C613, 614	CERAMIC CAPACITOR	CKDYX183M25
C615, 616	ELECTR.CAPACITOR	CEAS2R2M50
C617, 618	ELECTR.CAPACITOR	CEAS100M25
C619, 620	CERAMIC CAPACITOR	CCDSL390J50
C625, 626	CERAMIC CAPACITOR	CKDYX104M25
C627, 628	CERAMIC CAPACITOR	CKDYX823M25
C629, 630	ELECTR.CAPACITOR	CEAS470M25
C631, 632	ELECTR.CAPACITOR	CEAS221M25
C635, 636	CERAMIC CAPACITOR	CCDSL150J50
C641, 642	CERAMIC CAPACITOR	CCCSL470J50
C643	CERAMIC CAPACITOR	CKCYF103Z50
C645, 646	CERAMIC CAPACITOR	CKCYB102K50
C647, 648	CERAMIC CAPACITOR	CCCSL820J50
<b>RESISTORS</b>		
VR603, 604	VARIABLE (100K-20AX2)	ACT1045
R651, 652	CARBON FILM RESISTOR	RD1/4PM101J
R857	CARBON FILM RESISTOR	RD1/4PM331J
	Other resistors	RD1/8PM□□□J

**● TONE ASSEMBLY (AWZ3492)  
(FOR A - 450R)**

**SEMICONDUCTORS**

IC601, 602	OP-AMP IC	RC4558DXP
Q851, 852	TRANSISTOR	DTC143ES
D602	LED (RED)	AEL1065
D603	LED	AEL1084
D607	LED (RED)	AEL1065

**SWITCHES**

S602	PUSH SWITCH	ASG1019
S604	SWITCH	ASG1029

Mark No.	Description	Parts No.
<b>CAPACITORS</b>		
C601, 602	ELECTR.CAPACITOR	CEAS010M50
C605, 606	ELECTR.CAPACITOR	CEAS2R2M50
C607, 608	CERAMIC CAPACITOR	CKDYX153M25
C609, 610	CERAMIC CAPACITOR	CKDYX823M25
C611, 612	CERAMIC CAPACITOR	CKCYB332K50
C613, 614	CERAMIC CAPACITOR	CKDYX183M25
C615, 616	ELECTR.CAPACITOR	CEAS2R2M50
C617, 618	ELECTR.CAPACITOR	CEAS100M25
C619, 620	CERAMIC CAPACITOR	CCDSL390J50
C625, 626	CERAMIC CAPACITOR	CKDYX104M25
C627, 628	CERAMIC CAPACITOR	CKDYX823M25
C629, 630	ELECTR.CAPACITOR	CEAS470M25
C631, 632	ELECTR.CAPACITOR	CEAS221M25
C641, 642	CERAMIC CAPACITOR	CCCSL470J50
C645, 646	CERAMIC CAPACITOR	CKCYB102K50
C647, 648	CERAMIC CAPACITOR	CCDSL390J50
<b>RESISTORS</b>		
VR603, 604	VARIABLE (100K-20AX2)	ACT1045
R651, 652	CARBON FILM RESISTOR	RD1/4PM101J
R857	CARBON FILM RESISTOR	RD1/4PM331J
	Other resistors	RD1/8PM□□□J

**FUSE ASSEMBLY**

**CAPACITOR**

C953	CKA (0.01/AC400V)	ACG1002
------	-------------------	---------

## 5. ADJUSTMENTS

### IDLE CURRENT ADJUSTMENT

1. Connect measuring instrument as Fig. 5-1.
2. Set the VOLUME CONTROL to minimum.
3. Set the POWER switch to ON.
4. Adjust VR201 (VR202) so that the voltage between TP1 (TP3) and TP2 (TP4) becomes  $20\text{mV} \pm 3\text{mV}$ .

*NOTE)*

*After turning on the power, wait at least 5 minutes before adjustment.*

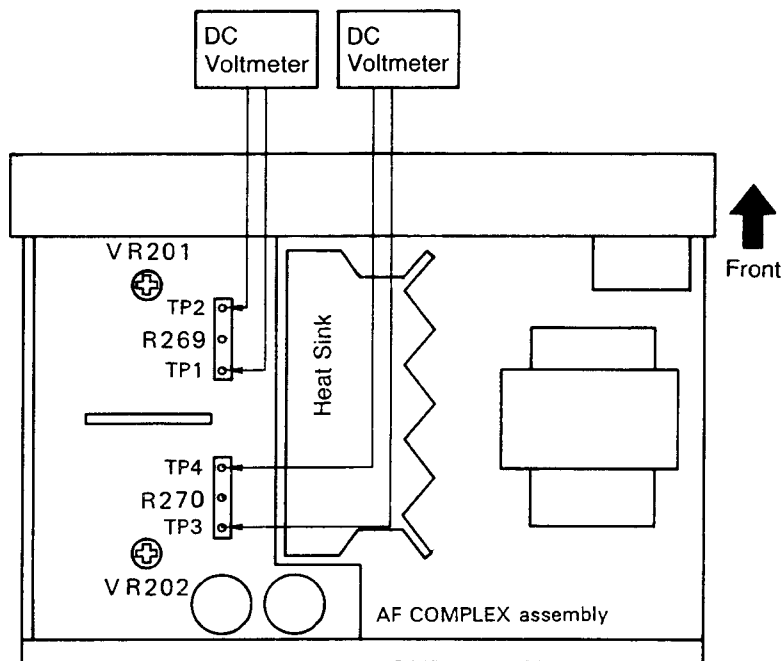

Fig. 5-1 Adjustment Method

## 5. RÉGLAGE

### RÉGLAGE DU COURANT DÉWATTÉ

1. Brancher les fils comme indiqué dans la fig. 5-1.
2. Après la mise sous tension, le moteur dure 5 minutes et n'introduire charge.
3. VR 201 sera réglé dans le canal gauche de manière que les deux tensions de bornes de R269 atteignent 20 mV ( $\pm 3$  mV).
4. VR 202 sera réglé dans le canal droit de manière que les deux tensions de bornes atteignent 20 mV ( $\pm 3$  mV).

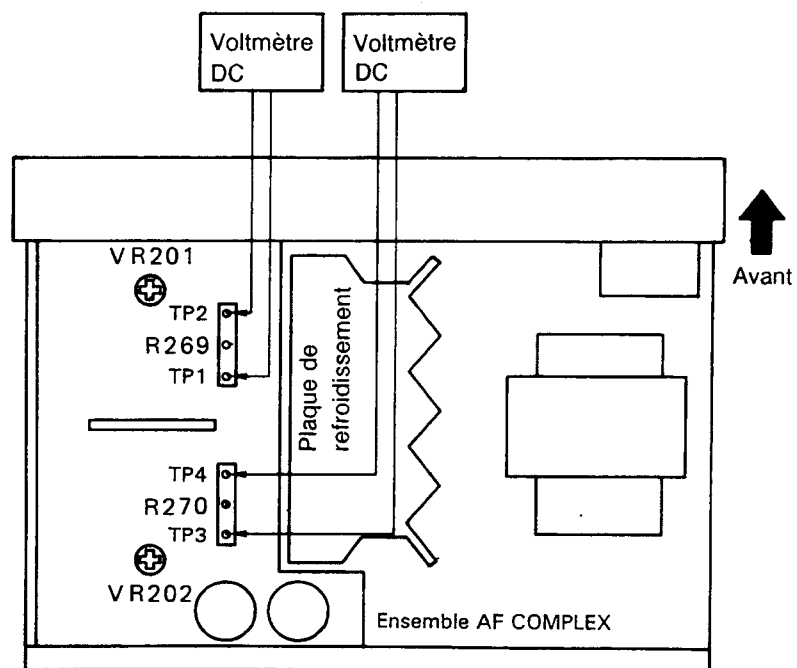

Fig. 5-1 Schéma du réglage

## 5. AJUSTE

### AJUSTE DE LA CORRIENTE DEVATIADA

1. Conecte el cable como lo ilustra la Fig. 5-1.
2. El motor funciona por 5 minutos después de encender la unidad, sin introduzca.
3. El VR201 del canal izquierdo debe ajustarse de modo que la tensión entre ambos bornes de R269 llegue a 20 mV ( $\pm 3$  mV).
4. El VR202 del canal derecho debe ajustarse de modo que la tensión entre ambos bornes llegue a 20 mV ( $\pm 3$  mV).

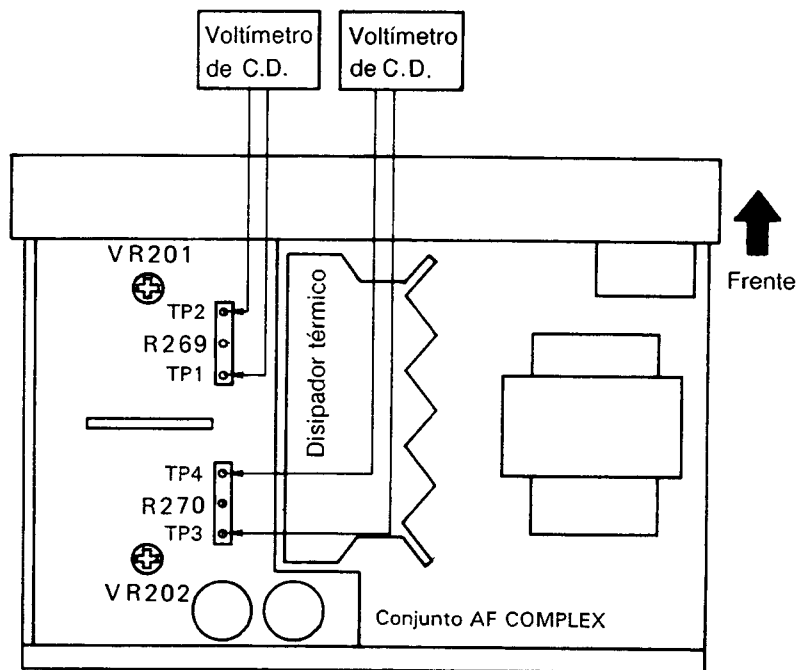
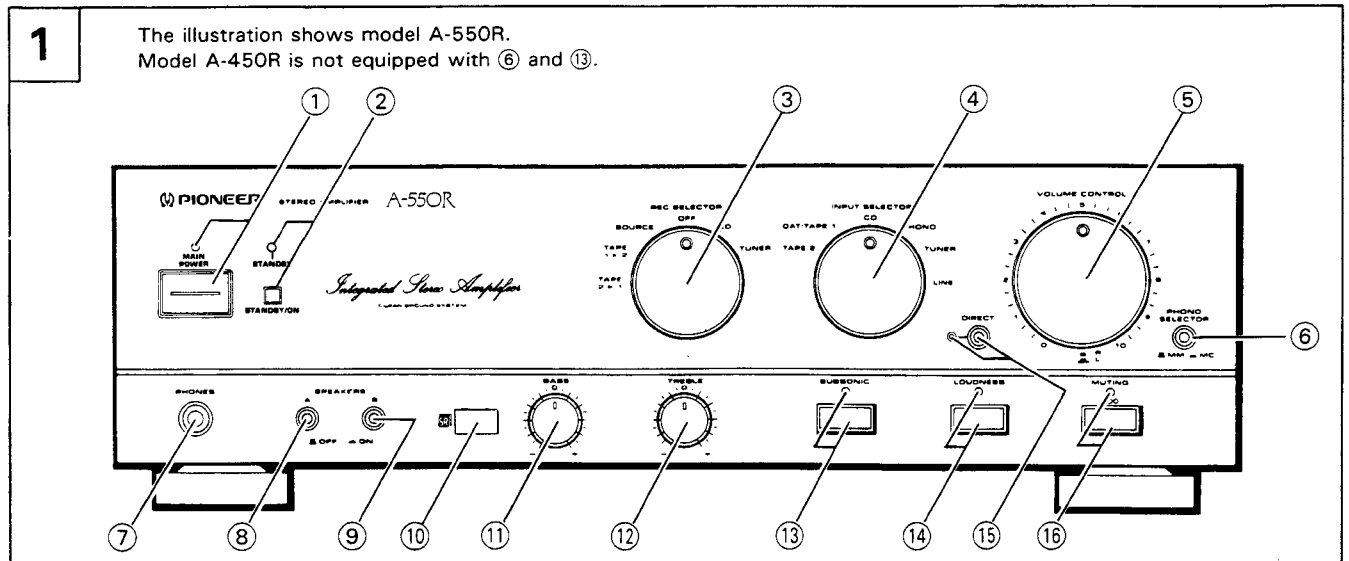

Fig. 5-1 Diagrama de ajuste



## 6. PANEL FACILITIES



### FRONT PANEL 1

#### ① MAIN POWER switch/indicator

Press to set the unit to the power STANDBY or ON condition. Press again to set to OFF.

#### ② STANDBY/ON button STANDBY indicator

To use the amplifier, press the MAIN POWER switch ON, then press the STANDBY/ON button so that the STANDBY indicator goes off. When the STANDBY indicator lights, the unit is in STANDBY.

When set to the STANDBY position, the main power flow is cut and the unit is no longer fully operational. A minute flow of power feeds the unit to maintain operation readiness.

#### NOTE:

When not using the unit for extended periods of time, set the MAIN POWER switch to OFF.

#### ③ REC SELECTOR switch

When this switch is set to a position other than SOURCE or OFF, the equipment selected by REC SELECTOR switch can be recorded from, irrespective of the settings of INPUT SELECTOR switch and DIRECT button.

**TUNER:** To record from the equipment connected to TUNER terminals.

**CD:** To record from the equipment connected to CD terminals.

**OFF:** In this position, nothing from REC terminals of DAT/TAPE 1 and TAPE 2 is output. Set to this position when not recording; the cassette deck will be disconnected, improving sound quality.

**SOURCE:** To record from the equipment selected by INPUT SELECTOR switch.

#### TAPE 1 ▶ 2:

To record (copy) from the cassette deck of DAT/TAPE 1 terminals, to the cassette deck of TAPE 2 terminals.

#### TAPE 2 ▶ 1:

To record (copy) from the cassette deck of TAPE 2 terminals, to the cassette deck of DAT/TAPE 1 terminals.

#### ④ INPUT SELECTOR switch

Use to select the playback source.

**LINE:** For playback with a component connected to LINE terminal.

**TUNER:** For AM or FM broadcast reception with a tuner.

**PHONO:** For record playback with a turntable.

#### NOTE:

- With the A-450R, you can use an MM cartridge or a high-output MC cartridge (over 1 mV).

- According to the type of cartridge used with the A-550R, you can select MM or MC with the PHONO SELECTOR button.

**CD:** For compact disc playback with a CD player.

#### DAT/TAPE 1:

For playback with a cassette deck or digital audio tape deck connected to DAT/TAPE 1 terminals.

**TAPE 2:** For playback with a cassette deck connected to TAPE 2 terminals.

#### ⑤ VOLUME CONTROL

Use to adjust the volume level.

This volume knob consists of two volume controls. Because you can adjust L (left) and R (right) channel volume levels independently, it also functions as a balance control.

#### [Example]

To raise R (right) channel volume level, prevent the L knob from turning with one hand, and turn the R knob with the other hand.

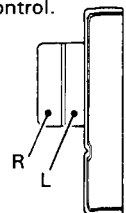

#### NOTE:

This unit is equipped with a circuit that attenuates LOUDNESS and TONE effect as volume is turned up.

## ⑥ PHONO SELECTOR button (A-550R only)

Set in accordance with the type of cartridge used with your turntable.

**MM (■):** Set to this position when using a moving magnet cartridge, or a moving coil cartridge with a high output of 1 mV or more.

**MC (■):** Set to this position when using a moving coil cartridge.

## ⑦ PHONES jack

When using headphones, insert the plug into this jack.

## ⑧ SPEAKERS A selector button

Use this button to listen to the speaker systems connected to SPEAKERS A terminals.

**ON (■):** Depressed position: Sound is heard from the speaker systems.

**OFF (■):** Released position: No sound is heard from the speaker systems. Set to this position when listening with headphones.

## ⑨ SPEAKERS B selector button

Use this button to listen to the speaker systems connected to SPEAKERS B terminals.

**ON (■):** Depressed position: Sound is heard from the speaker systems.

**OFF (■):** Released position: No sound is heard from the speaker systems. Set to this position when listening with headphones.

## ⑩ Remote control sensor window

## ⑪ BASS tone control

Use to adjust the low-frequency tone. The center position is the flat (normal) position. When turned to the right, low-frequency tones are emphasized; when turned to the left, low-frequency tones are de-emphasized.

**NOTE:**

- *This control does not operate when DIRECT button is in the on position.*
- *At volume levels lower than "4," the set tone control effect is obtained.*  
*At volume levels higher than "4," the effect becomes increasingly weaker.*

## ⑫ TREBLE tone control

Use to adjust the high-frequency tone. The center position is the flat (normal) position. When turned to the right, high-frequency tones are emphasized; when turned to the left, high-frequency tones are de-emphasized.

**NOTE:**

- *This control does not operate when DIRECT button is in the on position.*
- *At volume levels lower than "4," the set tone control effect is obtained.*  
*At volume levels higher than "4," the effect becomes increasingly weaker.*

## ⑬ SUBSONIC filter button/indicator (A-550R only)

Use this button when playing records with coarse grooves.

**on:** The indicator lights: In this position, frequencies of 17 Hz and below are cut, eliminating super-low-frequency noise caused by coarse record grooves, and thus helping prevent sound distortion.

**off:** The indicator goes off: Leave in this position for normal playback.

**NOTE:**

*This button does not operate when DIRECT button is in the on position.*

## ⑭ LOUDNESS button/indicator

Use when listening at low volume levels.

**on:** The indicator lights: Boosts low and high frequencies to give added punch to playback even at low volume levels.

**off:** The indicator goes off: Should normally be left in this position.

**NOTE:**

*This button does not operate when DIRECT button is in the on position.*

## ⑮ DIRECT button/indicator

Use this button/indicator when you do not wish to pass the output from input terminal equipment through the various frequency adjusting circuits (BASS, TREBLE, SUBSONIC, LOUDNESS) and adaptor terminals (ADAPTOR).

**on:** The indicator lights: The signals input through the input terminals are reproduced without passing through the various frequency adjusting circuits. This results in flat, pure sound which is a more faithful reproduction of the input source.

**off:** The indicator goes out: The signal passes through the various frequency adjusting circuits.

## ⑯ MUTING button/indicator

Use to temporarily cut sound volume.

**on:** The indicator lights.  
The sound is cut off.

**off:** the indicator goes off.  
The sound will return to its previous volume.

## 7. SPECIFICATIONS

### [A-550R]

#### Amplifier Section

Continuous power output (both channels driven at 20 Hz to 20 kHz)\*\*

T.H.D. 0.009%, 8 Ω	60 W + 60 W*
T.H.D. 0.02%, 4 Ω	80 W + 80 W*
DIN Continuous power output (both channels driven at 1 kHz)	
T.H.D. 1%, 8 Ω	70 W + 70 W*
T.H.D. 1%, 4 Ω	100 W + 100 W*

Dynamic power output (on EIA dynamic test signal)

8 Ω/4 Ω/2 Ω	75 W/110 W/150 W
-------------	------------------

Total harmonic distortion\*\*

20 Hz to 20 kHz, 60 W, 8 Ω	0.009%*
20 Hz to 20 kHz, 80 W, 4 Ω	0.02%*

- The above values are applicable when AC 230 V power is supplied.

Input sensitivity/impedance

PHONO (MM)	2.5 mV/50 kΩ
PHONO (MC)	0.2 mV/100 Ω
CD, TUNER, LINE, TAPE	150 mV/40 kΩ

PHONO overload level

1 kHz, T.H.D. 0.008% (MM/MC)	150 mV/12 mV
------------------------------	--------------

Output level/impedance

TAPE REC, ADAPTOR OUTPUT	150 mV/2.2 kΩ
--------------------------	---------------

Frequency response

PHONO (MM)	20 Hz to 20 kHz ± 0.3 dB
PHONO (MC)	20 Hz to 20 kHz ± 0.5 dB
CD, TUNER, LINE, TAPE	5 Hz to 100 kHz ±3 dB*

Tone control (volume control set at -30 dB position)

BASS	± 8 dB (100 Hz)
TREBLE	± 8 dB (10 kHz)

Loudness contour (volume control set at -30 dB position)

	+ 5 dB (100 Hz)/+ 3 dB (10 kHz)
--	---------------------------------

Filter (SUBSONIC)

	17 Hz (12 dB/oct.)
--	--------------------

Signal-to-Noise ratio (IHF short circuit, A network)

PHONO (MM, 5 mV input/MC, 0.5 mV input)	93 dB/74 dB*
CD, TUNER, LINE, TAPE	108 dB*

Signal-to-Noise ratio (DIN, continuous power/50 mW)

PHONO (MM)	74 dB/63 dB*
CD, TUNER, LINE, TAPE	88 dB/65 dB*

MUTING

	-∞
--	----

#### Power Supply/Miscellaneous

Power requirements	a.c. 220~230 Volts, 50/60 Hz
Power consumption	550 W
Dimensions	420 (W) × 352 (D) × 126 (H) mm
Weight (without package)	9.1 kg

#### Accessories

Remote control unit	1
Batteries (IEC R03, AAA)	2
Operating instructions	1

#### NOTE:

Specifications and design subject to possible modification without notice, due to improvements.

- \* Measured with DIRECT button set to on.
- \*\* Measured by Audio Spectrum Analyzer.

### [A-450R]

#### Amplifier Section

Continuous power output (both channels driven at 20 Hz to 20 kHz)\*\*

T.H.D. 0.01%, 8 Ω	40 W + 40 W*
T.H.D. 0.02%, 4 Ω	50 W + 50 W*
DIN Continuous power output (both channels driven at 1 kHz)	
T.H.D. 1%, 8 Ω	55 W + 55 W*
T.H.D. 1%, 4 Ω	75 W + 75 W*

Dynamic power output (on EIA dynamic test signal)

8 Ω/4 Ω/2 Ω	55 W/90 W/100 W
-------------	-----------------

Total harmonic distortion\*\*

20 Hz to 20 kHz, 40 W, 8 Ω	0.01%*
20 Hz to 20 kHz, 50 W, 4 Ω	0.02%*

- The above values are applicable when AC 230 V power is supplied.

Input sensitivity/impedance

PHONO (MM)	2.5 mV/50 kΩ
CD, TUNER, LINE, TAPE	150 mV/40 kΩ

PHONO overload level

1 kHz, T.H.D. 0.02% (MM)	150 mV
--------------------------	--------

Output level/impedance

TAPE REC, ADAPTOR OUTPUT	150 mV/2.2 kΩ
--------------------------	---------------

Frequency response

PHONO (MM)	20 Hz to 20 kHz ± 0.3 dB
CD, TUNER, LINE, TAPE	5 Hz to 100 kHz ±3 dB*

Tone control (volume control set at -30 dB position)

BASS	± 8 dB (100 Hz)
TREBLE	± 8 dB (10 kHz)

Loudness contour (volume control set at -30 dB position)

	+ 5 dB (100 Hz)/+ 3 dB (10 kHz)
--	---------------------------------

Signal-to-Noise ratio (IHF short circuit, A network)

PHONO (MM, 5 mV input)	89 dB*
CD, TUNER, LINE, TAPE	108 dB*

Signal-to-Noise ratio (DIN, continuous power/50 mW)

PHONO (MM)	73 dB/63 dB*
CD, TUNER, LINE, TAPE	87 dB/65 dB*

#### Power Supply/Miscellaneous

Power requirements	a.c. 220~230 Volts, 50/60 Hz
Power consumption	410 W
Dimensions	420 (W) × 352 (D) × 126 (H) mm
Weight (without package)	8.1 kg

#### Accessories

Remote control unit	1
Batteries (IEC R03, AAA)	2
Operating instructions	1

#### NOTE:

Specifications and design subject to possible modification without notice, due to improvements.

- \* Measured with DIRECT button set to on.
- \*\* Measured by Audio Spectrum Analyzer.

