

# Service Manual

**PIONEER®**  
The Art of Entertainment

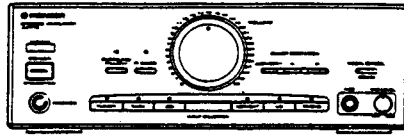

ORDER NO.  
ARP2179

STEREO AMPLIFIER

# A-P710

# A-P510

A-P710 AND A-P510 HAVE THE FOLLOWING :

Type	Model		Power Requirement	Remarks
	A-P710	A-P510		
HE	○	○	AC 220V, 240V (switchable) *	
HB	○	○	AC 220V, 240V (switchable) *	
HEWZIW	○	○	AC 220V, 240V (switchable) *	
KUC	-	○	AC120V only	
SD	○	○	AC110V, 120V-127V, 220V, 240V (switchable)	

\* Change the connection of the power transformer lead wire.

- This manual is applicable to the A-P710/HE, HB, A-P510/HE and HB types.
- As to the A-P710/HB and A-P510/HB types, refer to page 40.
- As to the other types, refer to applicable service manual.
- These products are components of systems. As to the system composition, refer to the system manuals.
- Each of these products does not function properly when independent; to avoid malfunctions, be sure to connect it to the prescribed system components, otherwise damage may result.

## CONTENTS

1. SAFETY INFORMATION .....	2	5. DISASSEMBLY .....	38
2. EXPLODED VIEWS, PACKING AND PARTS LIST .....	3	6. IC INFORMATION .....	39
3. SCHEMATIC DIAGRAM AND P.C.BOARDS CONNECTION DIAGRAM .....	7	7. FOR A-P710/HB AND A-P510/HB TYPES .....	40
4. PCB 's PARTS LIST .....	31	8. PANEL FACILITIES .....	41
		9. SPECIFICATIONS .....	44

**PIONEER ELECTRONIC CORPORATION** 4-1, Meguro 1-Chome, Meguro-ku, Tokyo 153, Japan

**PIONEER ELECTRONICS SERVICE INC.** P.O. Box 1760, Long Beach, California 90801 U.S.A.

**PIONEER ELECTRONICS OF CANADA, INC.** 505 Cochrane Drive, Markham, Ontario L3R 8E3 Canada

**PIONEER ELECTRONIC [EUROPE] N.V.** Keetberglaan 1, 2740 Beveren, Belgium

**PIONEER ELECTRONICS AUSTRALIA PTY. LTD.** 178-184 Boundary Road, Braeside, Victoria 3195, Australia TEL: [03] 580-9911

© PIONEER ELECTRONIC CORPORATION 1991

YV FEB. 1991 Printed in Japan.

This service manual is intended for qualified service technicians; it is not meant for the casual do-it-yourselfer. Qualified technicians have the necessary test equipment and tools, and have been trained to properly and safely repair complex products such as those covered by this manual.

Improperly performed repairs can adversely affect the safety and reliability of the product and may void the warranty. If you are not qualified to perform the repair of this product properly and safely, you should not risk trying to do so and refer the repair to a qualified service technician.

**WARNING**

Lead in solder used in this product is listed by the California Health and Welfare agency as a known reproductive toxicant which may cause birth defects or other reproductive harm (California Health & Safety Code, Section 25249.5).

When servicing or handling circuit boards and other components which contain lead in solder, avoid unprotected skin contact with the solder. Also, when soldering do not inhale any smoke or fumes produced.

**1. SAFETY INFORMATION**

(FOR USA MODEL ONLY)

**1. SAFETY PRECAUTIONS**

The following check should be performed for the continued protection of the customer and service technician.

**LEAKAGE CURRENT CHECK**

Measure leakage current to a known earth ground (water pipe, conduit, etc.) by connecting a leakage current tester such as Simpson Model 229-2 or equivalent between the earth ground and all exposed metal parts of the appliance (input/output terminals, screwheads, metal overlays, control shaft, etc.). Plug the AC line cord of the appliance directly into a 120V AC 60Hz outlet and turn the AC power switch on. Any current measured must not exceed 0.5mA.

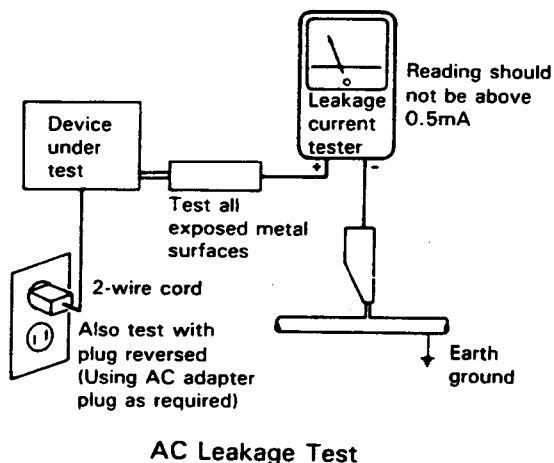

**ANY MEASUREMENTS NOT WITHIN THE LIMITS OUTLINED ABOVE ARE INDICATIVE OF A POTENTIAL SHOCK HAZARD AND MUST BE CORRECTED BEFORE RETURNING THE APPLIANCE TO THE CUSTOMER.**

**2. PRODUCT SAFETY NOTICE**

Many electrical and mechanical parts in the appliance have special safety related characteristics. These are often not evident from visual inspection nor the protection afforded by them necessarily can be obtained by using replacement components rated for voltage, wattage, etc. Replacement parts which have these special safety characteristics are identified in this Service Manual.

Electrical components having such features are identified by marking with a  $\Delta$  on the schematics and on the parts list in this Service Manual.

The use of a substitute replacement component which does not have the same safety characteristics as the PIONEER recommended replacement one, shown in the parts list in this Service Manual, may create shock, fire, or other hazards.

Product Safety is continuously under review and new instructions are issued from time to time. For the latest information, always consult the current PIONEER Service Manual. A subscription to, or additional copies of, PIONEER Service Manual may be obtained at a nominal charge from PIONEER.

## 2. EXPLODED VIEWS, PACKING AND PARTS LIST

### NOTES:

- Parts without part number cannot be supplied.
- The  $\Delta$  mark found on some component parts indicates the importance of the safety factor of the part. Therefore, when replacing, be sure to use parts of identical designa-
- Parts marked by "⊙" are not always kept in stock. Their delivery time may be longer than usual or they may be unavailable.

### 2.1 PARTS LIST OF EXTERIOR AND PACKING (A - P710/HE)

Mark	No.	Description	Parts No.	Mark	No.	Description	Parts No.
	1	VOLUME KNOB	AAB1181		36	INSULATOR ASSEMBLY	AMR2148
	2	KNOB (MIC LEVEL)	AAB1190		37	CHASSIS	
	3	A/M BUTTON (VOCAL CANCEL)	AAD1841		38	REAR PANEL	
	4	AI BUTTON (SMART OPERATION)	AAD1843		39	BONNET (FE)	ANE1260
	5	P/P BUTTON (SURROUND/PILLOW, P.BASS, POWER)	AAD1844		40	PACK HOLDER	
	6	FUNCTION BUTTON (INPUT SELECTOR, MEMORY)	AAD1980		41	HEAT SINK HOLDER	
	7	FUNCTION LENS	AAK2007		42	HOLDER (JACK)	
	8	INDICATOR LENS	AAK2008		43	HOLDER (FAN)	
	9	FILTER (REMOTE SENSOR)	AAK2010		44	HEAT SINK	
	10	MIC AMP ASSEMBLY			45	TRANS PRIMARY ASSEMBLY	
⊙	11	DISPLAY ASSEMBLY	AWZ3136		46	VOLUME ASSEMBLY	
	12	SP TERMINAL ASSEMBLY			47	DC MOTOR	AXM1009
	13	TRANS CONNECT ASSEMBLY			48	SCREW	BBZ26P100FMC
⊙	14	FUNCTION ASSEMBLY	AWZ3377		49	SCREW	BBZ30P060FZK
	15	H.P. ASSEMBLY			50	SCREW	BBZ30P080FZK
	16	SCREW	ABA-222		51	SCREW	BPZ26P080FMC
	17	SCREW	ABA1018		52	NUT	NK90FUC
	18	SCREW	ABA1024		53	FOOT (RUBBER)	REC-434
	19	SCREW	ABA1056		54	CKA (0.01/AC400V, C1)	ACG1003
	20	SCREW	ABA1074		55	FUSE (T1.25A, FU1)	AEK-510
	21	SCREW (STEEL)	ABA1095		56	FUSE (T2.5A, FU2)	AEK-509
	22	WASHER	ABE1020		57	FUSE (T2A, FU3)	AEK-017
$\Delta$	23	AC POWER CORD	ADG1019		58	FUSE (T2A, FU4)	AEK-017
	24	CUSHION (RUBBER)			59	FUSE (T2.5A, FU5)	AEK-403
	25	NYLON BINDER			60	FUSE (T2.5A, FU6)	AEK-403
	26	COVER (CAPACITOR)			61	POWER TRANSFORMER (T1)	ATS1332
	27	STRAIN RELIEF	AEC-882		62	TRANS COVER ASSEMBLY	
	28	PCB SPACER					
	29	SPACER					
⊙	30	AF ASSEMBLY	AWZ3385				
	31	FRONT PAD	AHA1325				
	32	REAR PAD	AHA1326				
	33	PACKING SHEET	AHG1175				
	34	FRONT PANEL ASSEMBLY	AMB1785				
	35	PCB MOULD					

### 2.2 PARTS LIST OF EXTERIOR AND PACKING (A - P510/HE)

Mark	No.	Description	Parts No.	Mark	No.	Description	Parts No.
	1	VOLUME KNOB	AAB1181		46	VOLUME ASSEMBLY	
	2	.....			47	DC MOTOR	AXM1009
	3	A/M BUTTON (MEMORY)	AAD1840		48	SCREW	BBZ26P100FMC
	4	AI BUTTON (SMART OPERATION)	AAD1842		49	SCREW	BBZ30P060FZK
	5	P/P BUTTON SURROUND & STEREO WIDE, POWER)	AAD1844		50	SCREW	BBZ30P080FZK
	6	FUNCTION BUTTON (INPUT SELECTOR)	AAD1979		51	SCREW	BPZ26P080FMC
	7	FUNCTION LENS	AAK2006		52	NUT	NK90FUC
	8	INDICATOR LENS	AAK2008	$\Delta$	53	FOOT (RUBBER)	REC-434
	9	FILTER (REMOTE SENSOR)	AAK2010	$\Delta$	54	CKA (0.01/AC400V, C1)	ACG1003
	10	.....		$\Delta$	55	FUSE (T1.25A, FU1)	AEK-510
⊙	11	DISPLAY ASSEMBLY	AWZ3135	$\Delta$	56	FUSE (T2.5A, FU2)	AEK-509
	12	SP TERMINAL ASSEMBLY		$\Delta$	57	FUSE (T2A, FU3)	AEK-017
	13	TRANS CONNECT ASSEMBLY		$\Delta$	58	FUSE (T2A, FU4)	AEK-017
⊙	14	FUNCTION ASSEMBLY	AWZ3375	$\Delta$	59	FUSE (T2.5A, FU5)	AEK-403
	15	H.P. ASSEMBLY		$\Delta$	60	FUSE (T2.5A, FU6)	AEK-403
	16	SCREW	ABA-222	$\Delta$	61	POWER TRANSFORMER (T1)	ATS1331
	17	SCREW	ABA1018		62	TRANS COVER ASSEMBLY	
	18	SCREW	ABA1024				
	19	SCREW	ABA1056				
	20	SCREW	ABA1074				
	21	SCREW (STEEL)	ABA1095				
	22	WASHER	ABE1020				
$\Delta$	23	AC POWER CORD	ADG1019				
	24	CUSHION (RUBBER)					
	25	NYLON BINDER					
	26	COVER (CAPACITOR)					
	27	STRAIN RELIEF	AEC-882				
	28	PCB SPACER					
	29	SPACER					
⊙	30	AF ASSEMBLY	AWZ3383				
	31	FRONT PAD	AHA1325				
	32	REAR PAD	AHA1326				
	33	PACKING SHEET	AHG1175				
	34	FRONT PANEL ASSEMBLY	AMB1781				
	35	PCB MOULD					
	36	INSULATOR ASSEMBLY	AMR2148				
	37	CHASSIS					
	38	REAR PANEL					
	39	BONNET (FE)	ANE1260				
	40	PACK HOLDER					
	41	HEAT SINK HOLDER					
	42	.....					
	43	HOLDER (FAN)					
	44	HEAT SINK					
	45	TRANS PRIMARY ASSEMBLY					

### • Packing

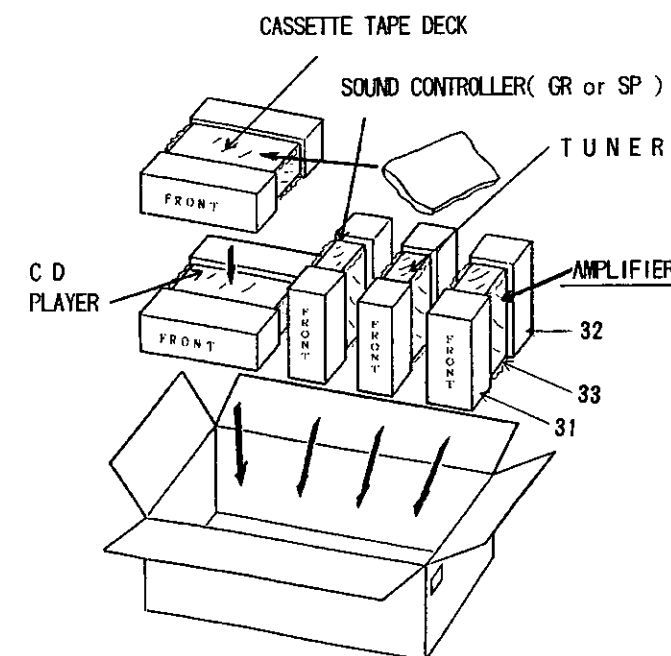

A

A-P51

B

2

15

C

D

**A-P710, A-P510**

• Exterior

Parts No.

AXM1009  
 BBZ26P100FMC  
 BBZ30P060FZK  
 BBZ30P080FZK

BPZ26P080FMC  
 NK90FUC  
 REC-434  
 ACG1003  
 AEK-510

AEK-509  
 AEK-017  
 AEK-017  
 AEK-403  
 AEK-403

ATS1331

A-P510 TYPE

A-P510 TYPE

A-P710 ONLY

A-P710 ONLY

A-P710 ONLY

ER (GR or SP)

TUNER

AMPLIFIER

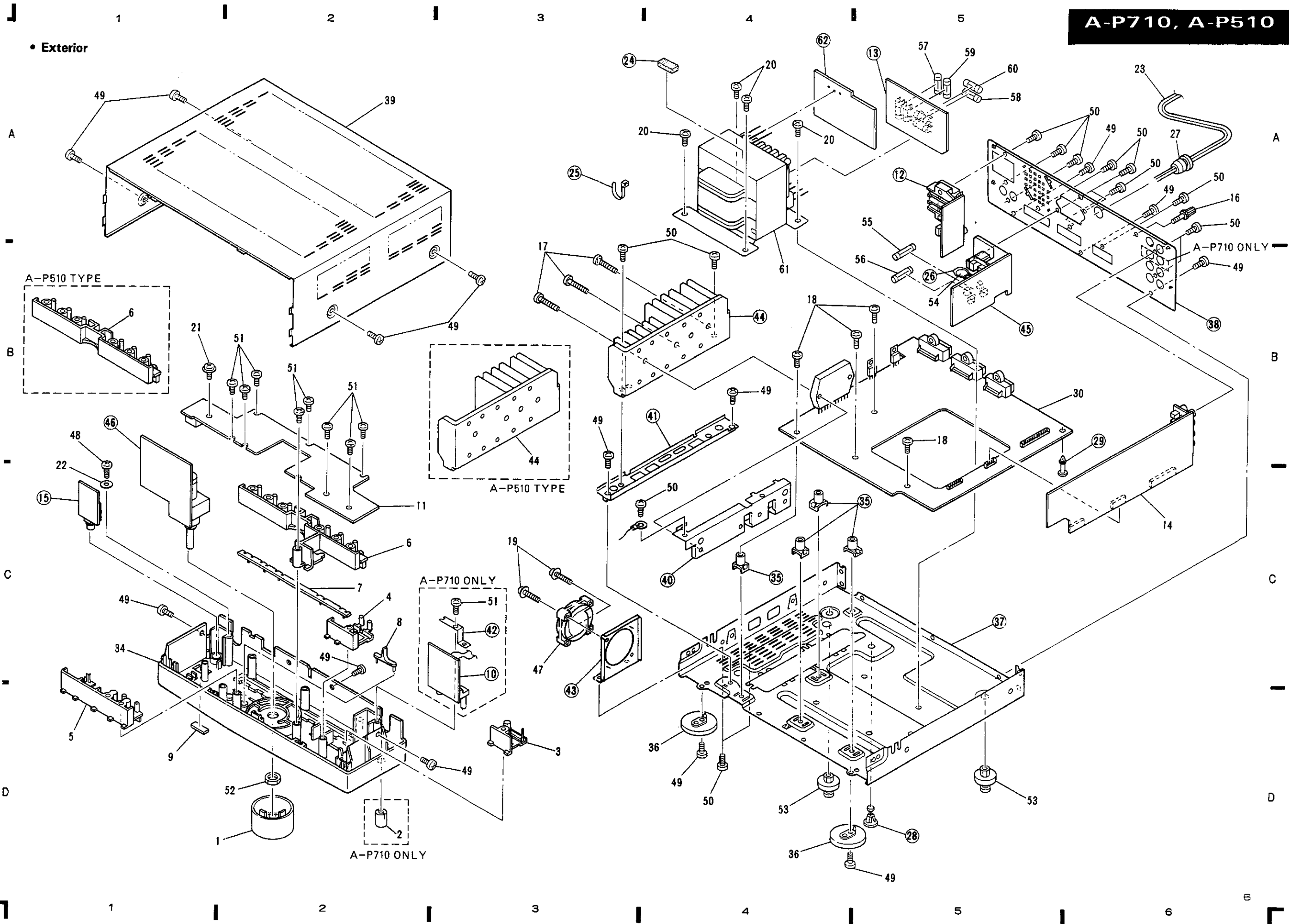

# 3. SCHEMATIC DIAGRAM AND P.C.BOARDS CONNECTION DIAGRAM 3.1 FOR A-P710

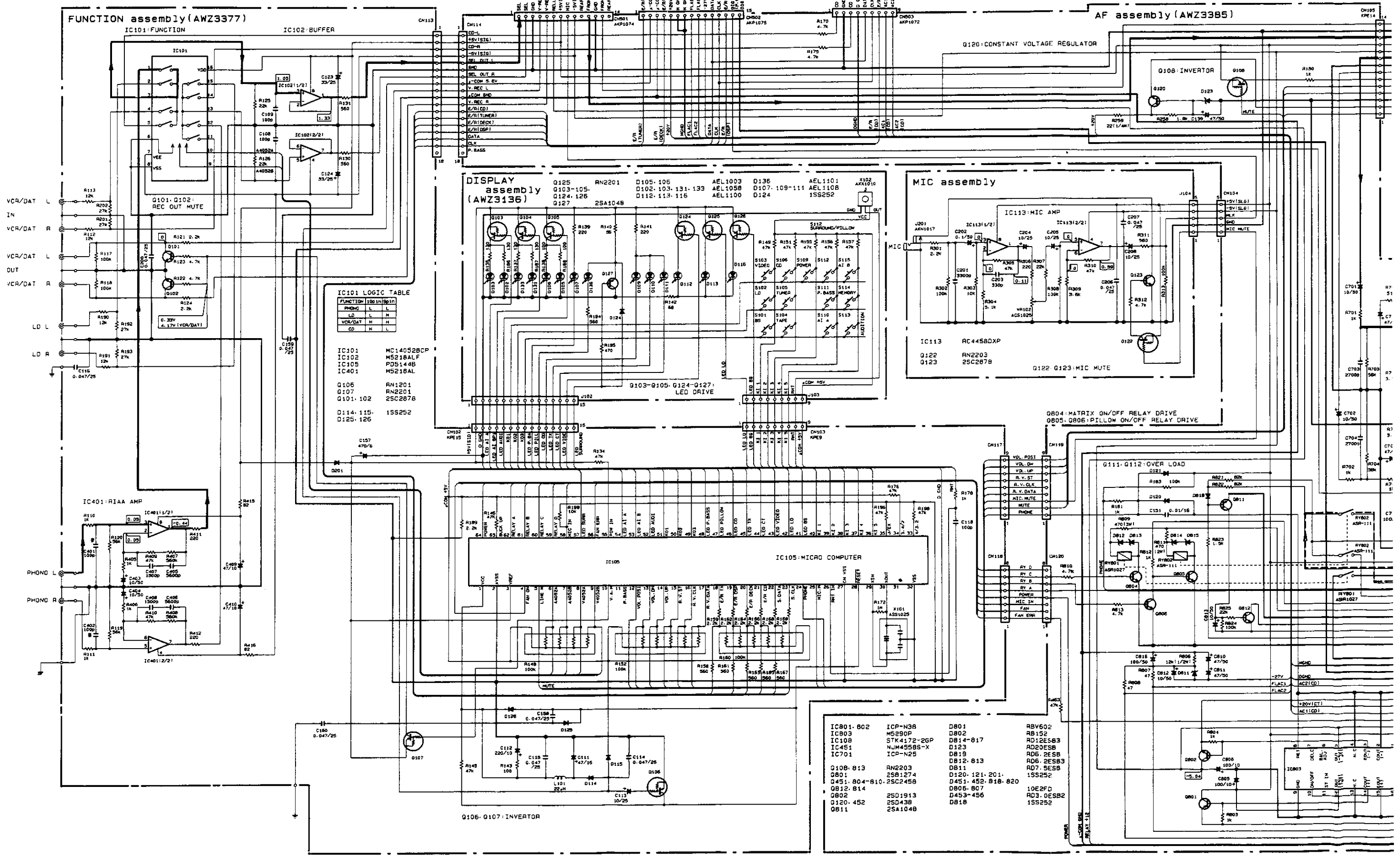

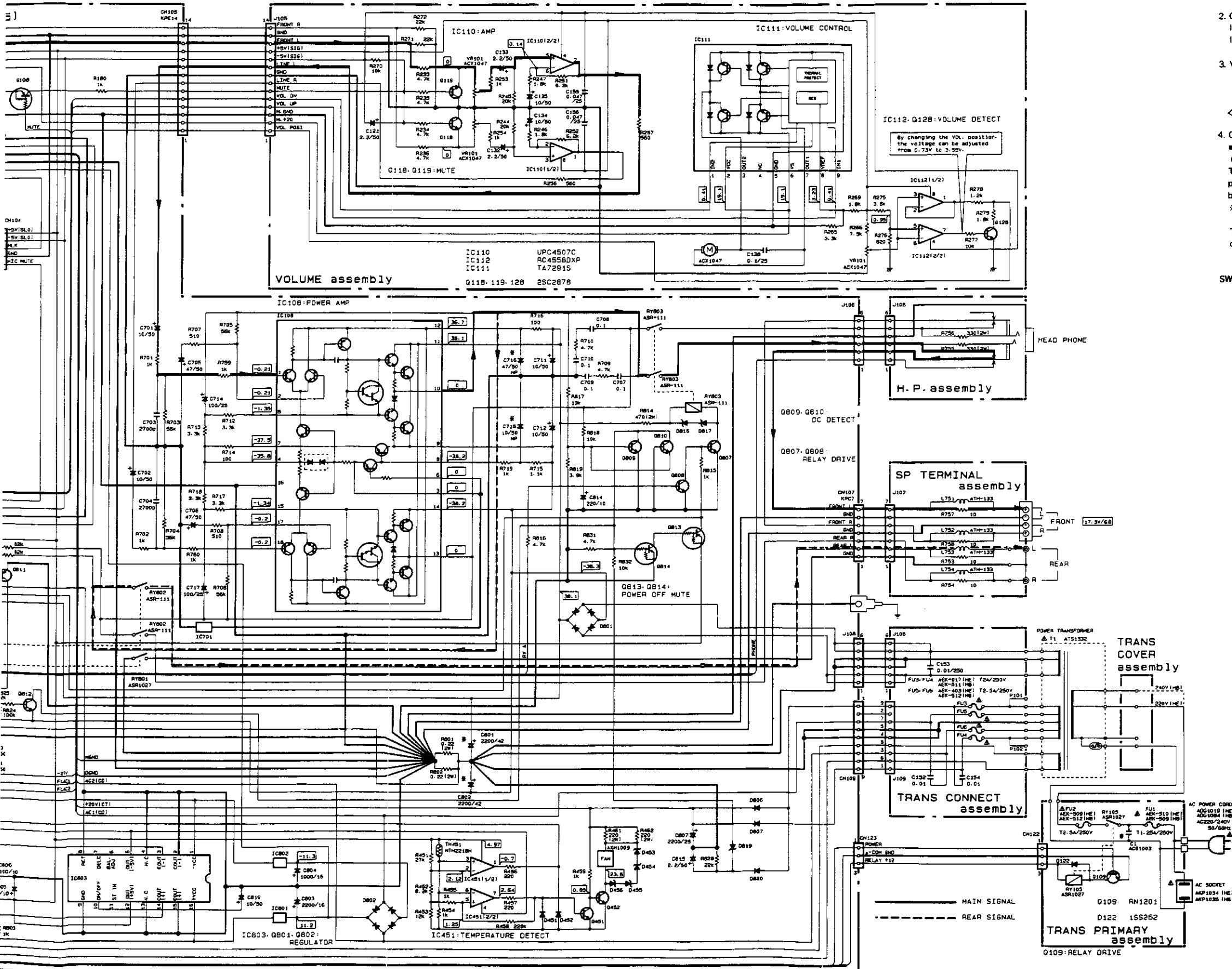

1. RESISTORS:  
Indicated in  $\Omega$ ,  $\frac{1}{4}W$ ,  $\frac{1}{2}W$ ,  $\pm 5\%$  tolerance unless otherwise noted k: k $\Omega$ , M: M $\Omega$ , (F):  $\pm 1\%$ , (G):  $\pm 2\%$ , (K):  $\pm 10\%$  (M):  $\pm 20\%$  tolerance

2. CAPACITORS:  
Indicated in capacity ( $\mu F$ )/voltage (V) unless otherwise noted p: pF  
Indication without voltage is 50V except electrolytic capacitor.

3. VOLTAGE, CURRENT:  
[Symbol] : Signal voltage at (40W + 40W 8  $\Omega$ ) output, DIN(1kHz).  
[Symbol] : DC voltage (V) at no input signal  
Value in ( ) is DC voltage at rated power.  
[Symbol] mA: DC current at no input signal

4. OTHERS:  
[Symbol] : Signal route.  
[Symbol] : Adjusting point.  
The  $\Delta$  mark found on some component parts indicates the importance of the safety factor of the part. Therefore, when replacing, be sure to use parts of identical designation.  
\* marked capacitors and resistors have parts numbers.

This is the basic schematic diagram, but the actual circuit may vary due to improvements in design.

SWITCHES:

DISPLAY assembly

- S101 PHONO
- S102 LD
- S103 VIDEO
- S104 TAPE
- S105 TUNER
- S106 CD
- S109 POWER
- S110 AI A
- S111 P-BASS
- S112 SURROUND
- S113 AUDITION
- S114 MEMORY
- S115 AI B

Line Voltage Selection  
(For HE, HB and HEWZIW types)

Line voltage can be changed with following steps.

1. Disconnect the AC power cord.
2. Remove the Bonnet case.
3. Change the connection of the power transformer lead wire.
4. Stick the line voltage label on the rear panel.

Part No.	Description
AAX-193	220V label
AAX-192	240V label

— 220V  
- - - 240V

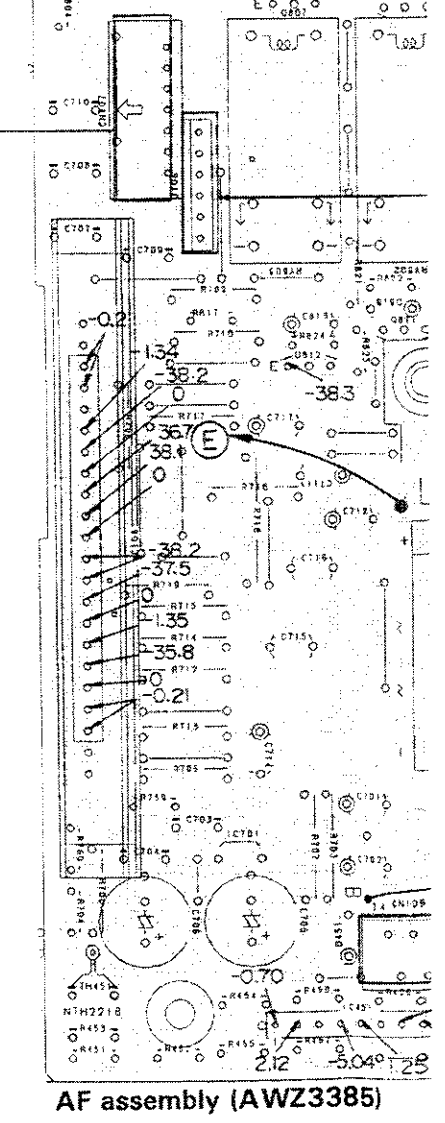
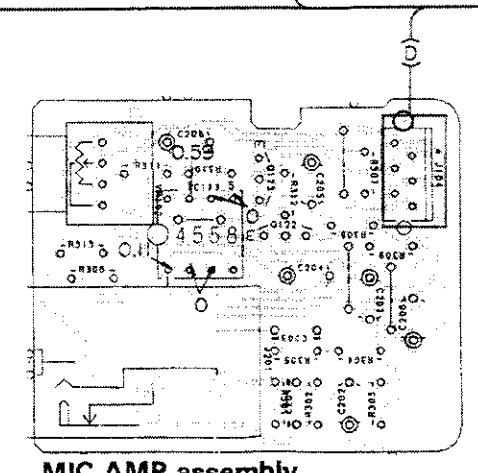
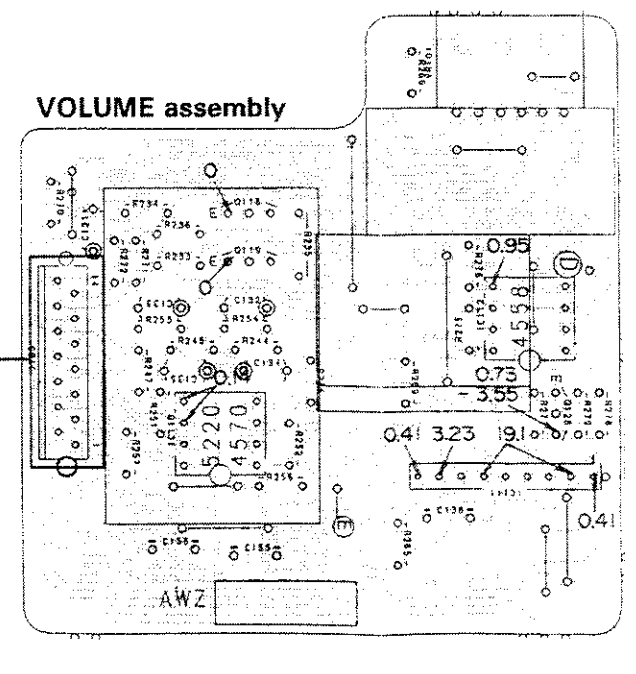
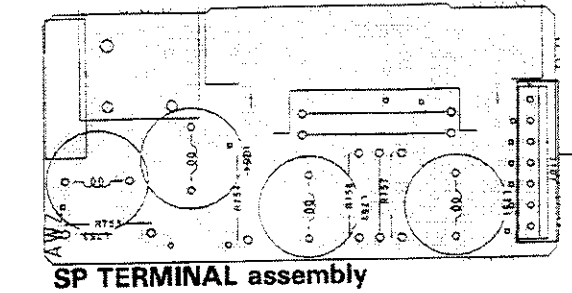
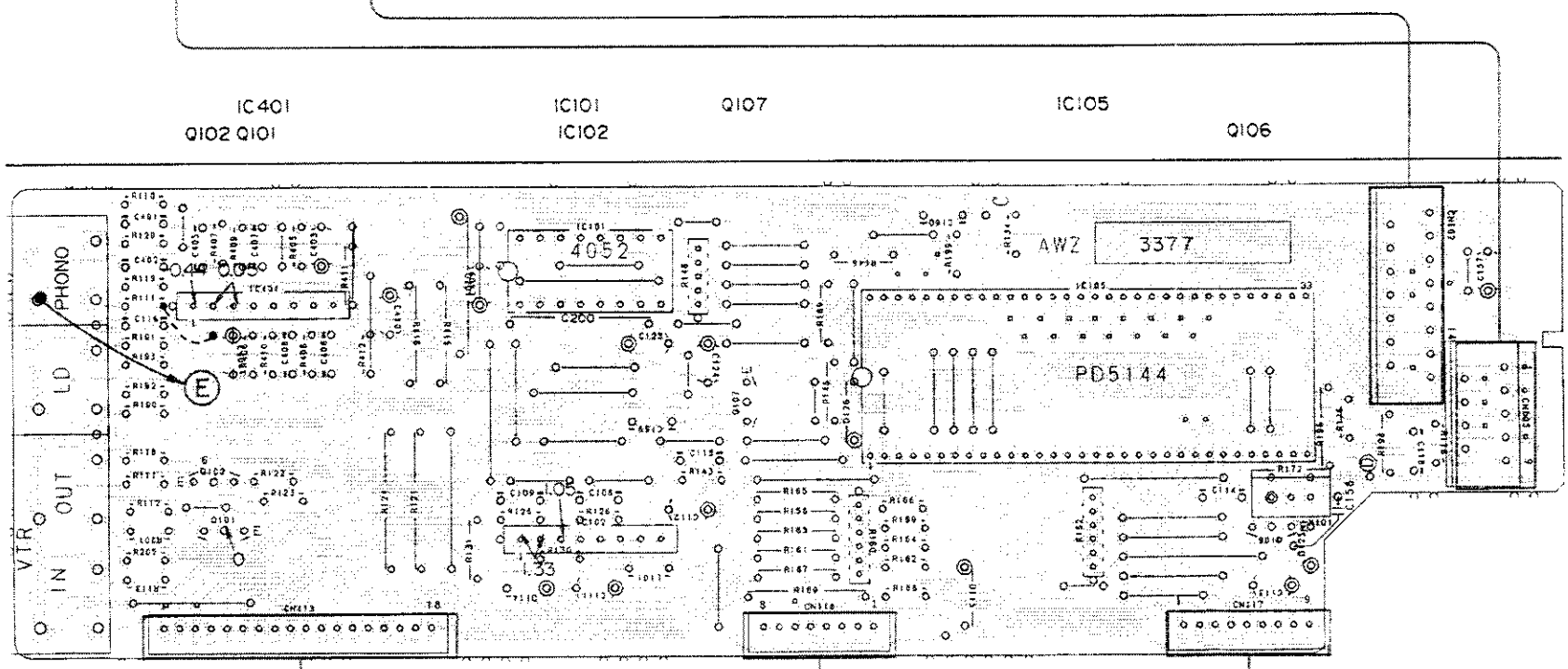
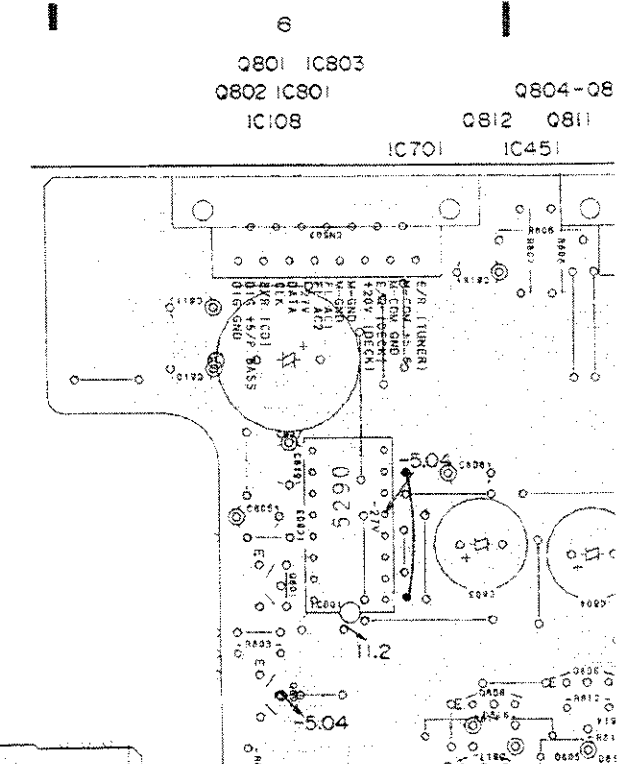
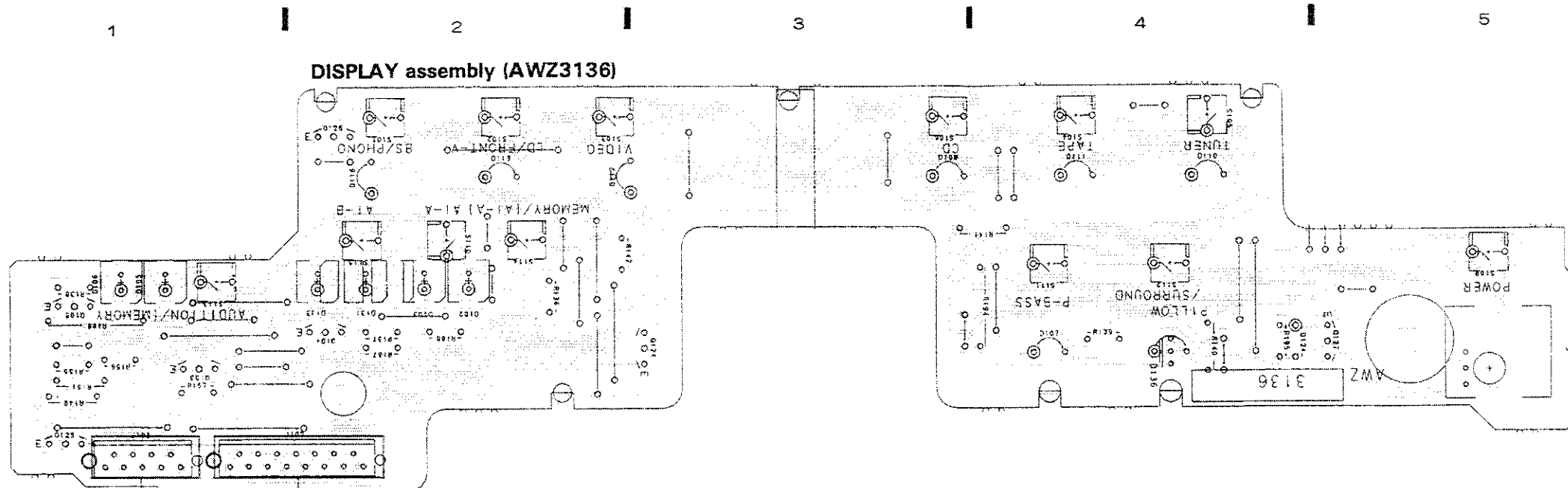



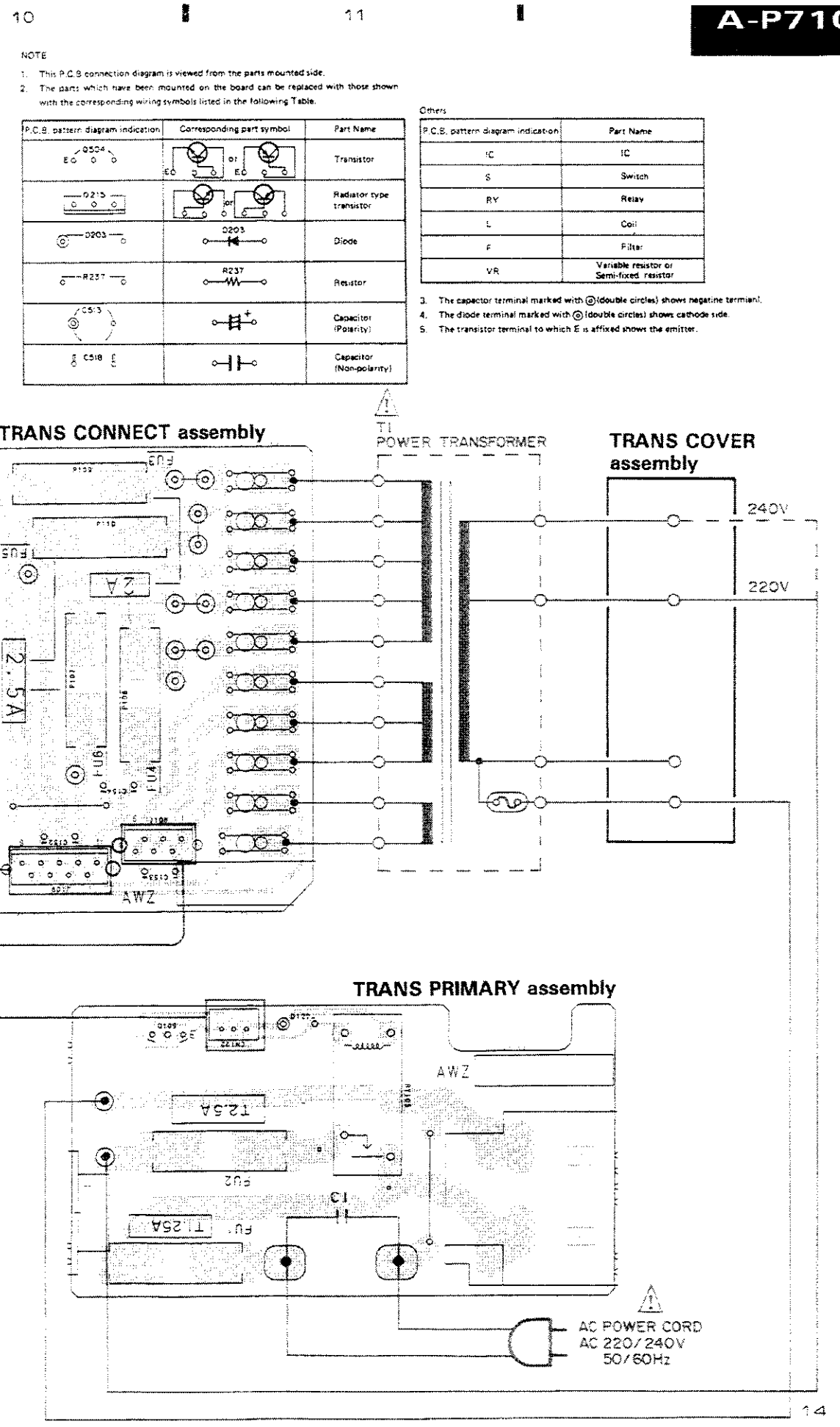
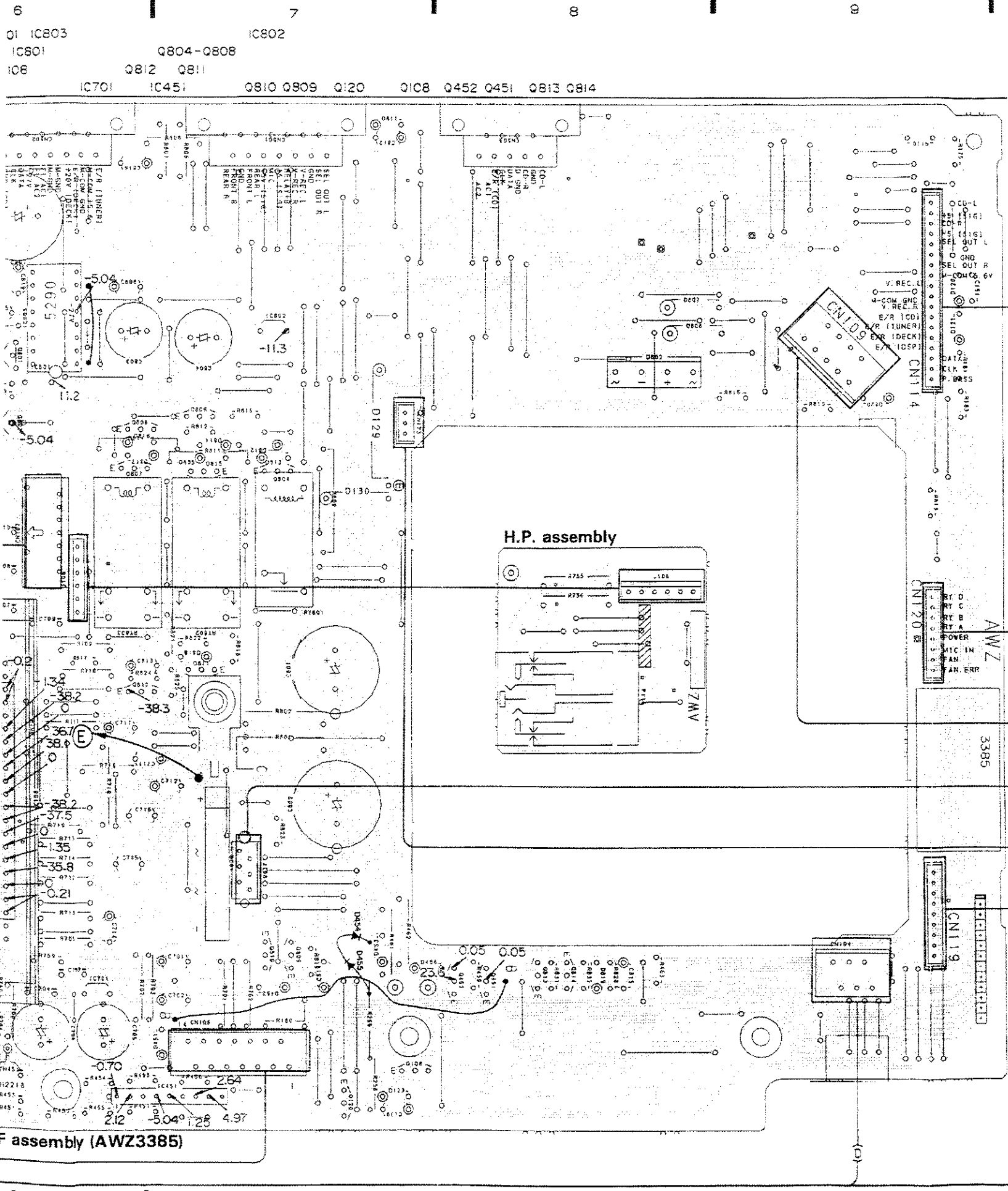

F assembly (AWZ3385)

AC POWER CORD  
AC 220/240V  
50/60Hz



A

B

C

D

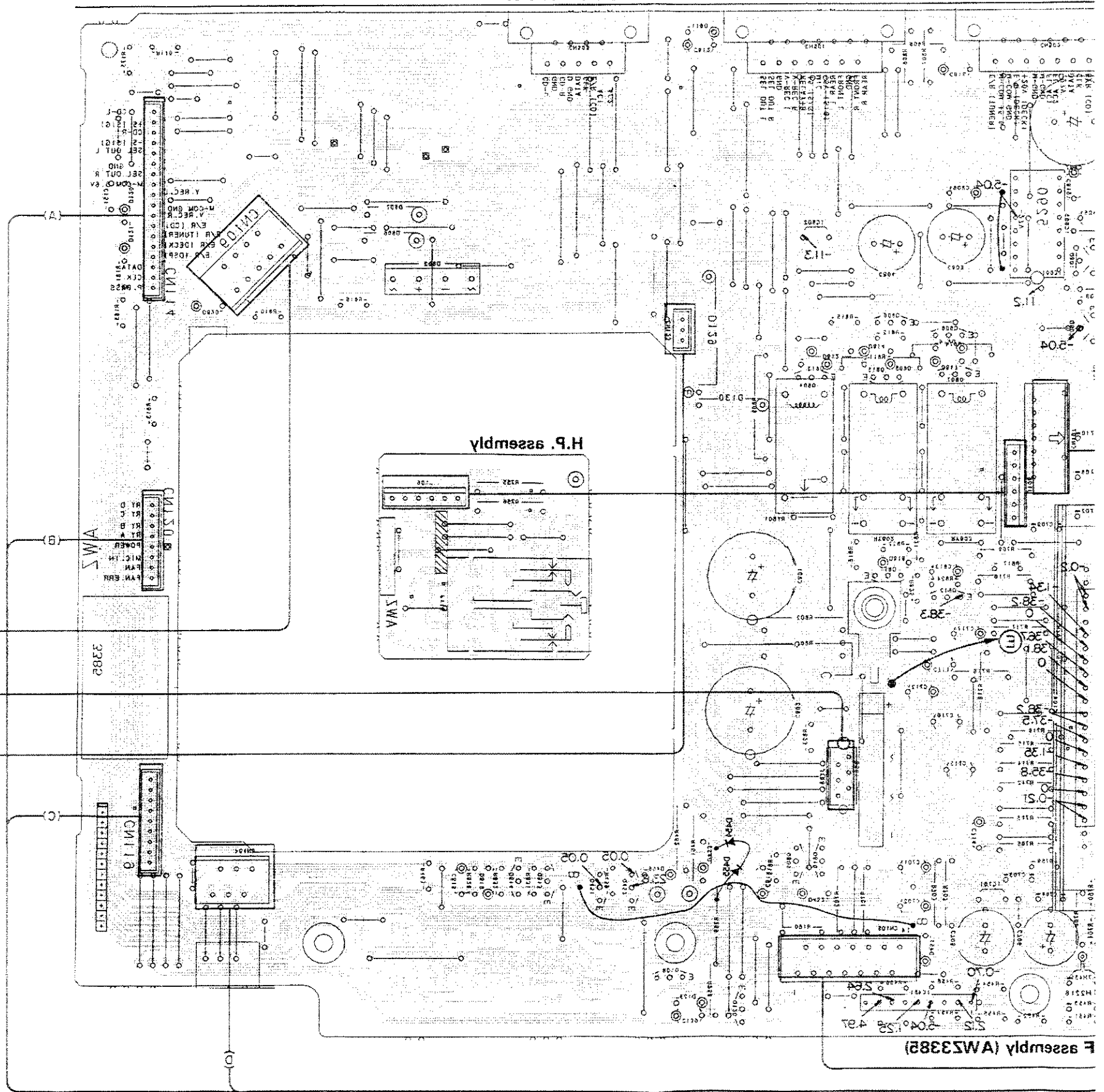
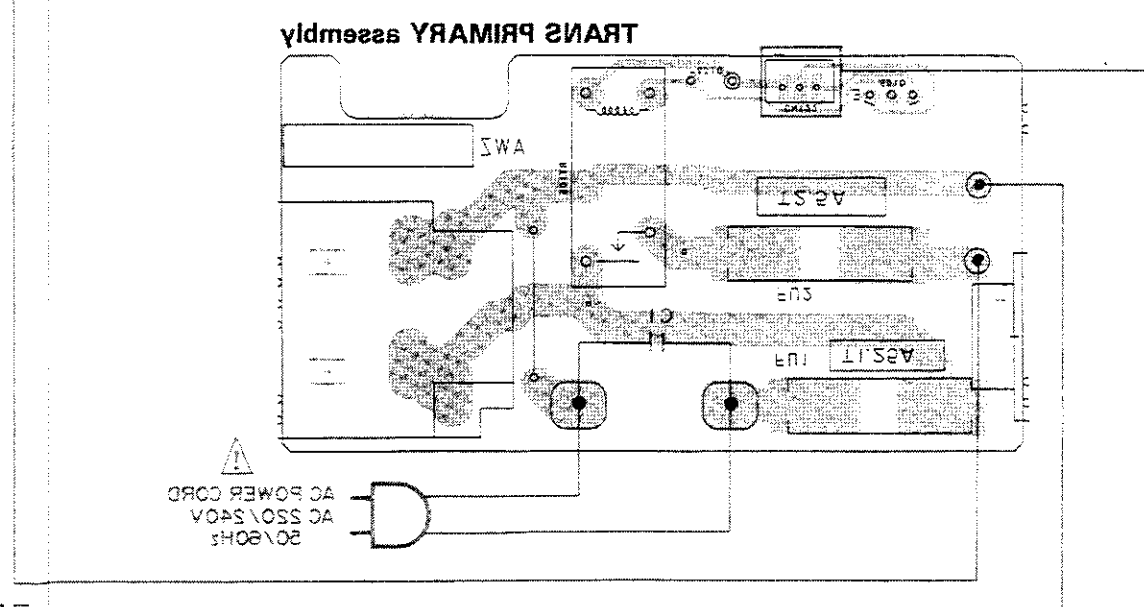
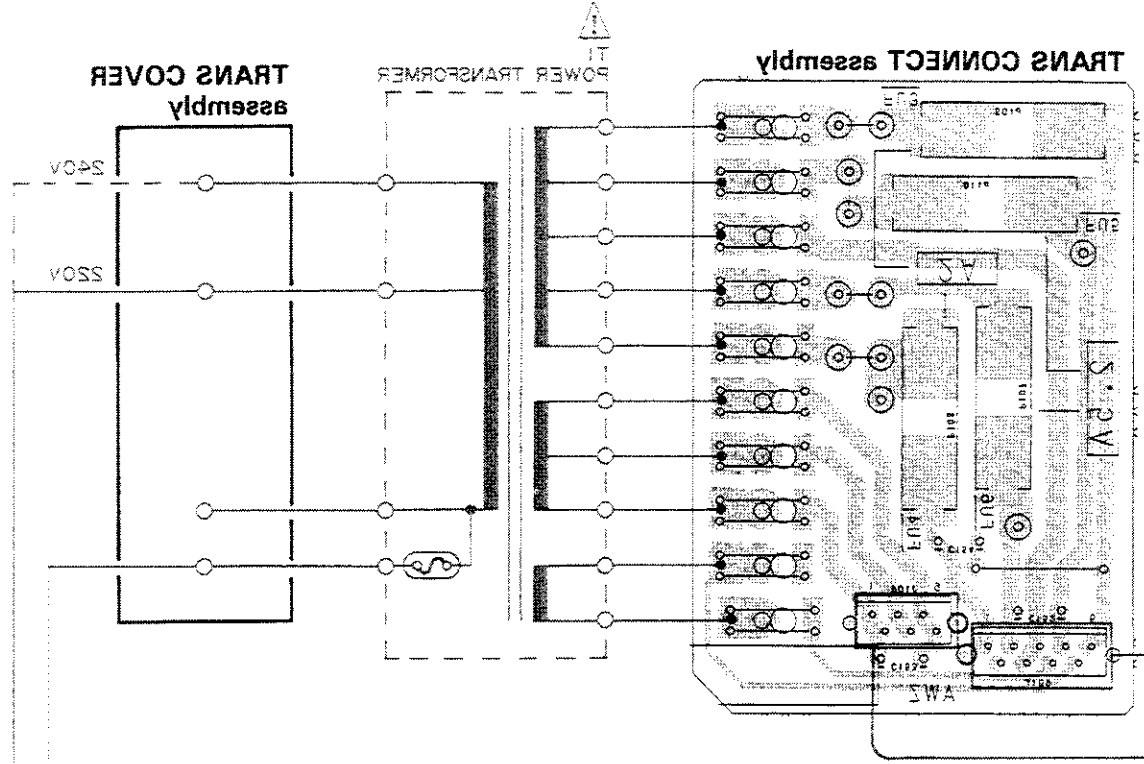

15

15

11

10

9

8

7

6

IC805

S IC801  
B01 IC803

IC21  
0815 0811  
0804-0808

0180 0421 0420 0421 0813 0814  
0150 0803 0150  
0810 0803 0150

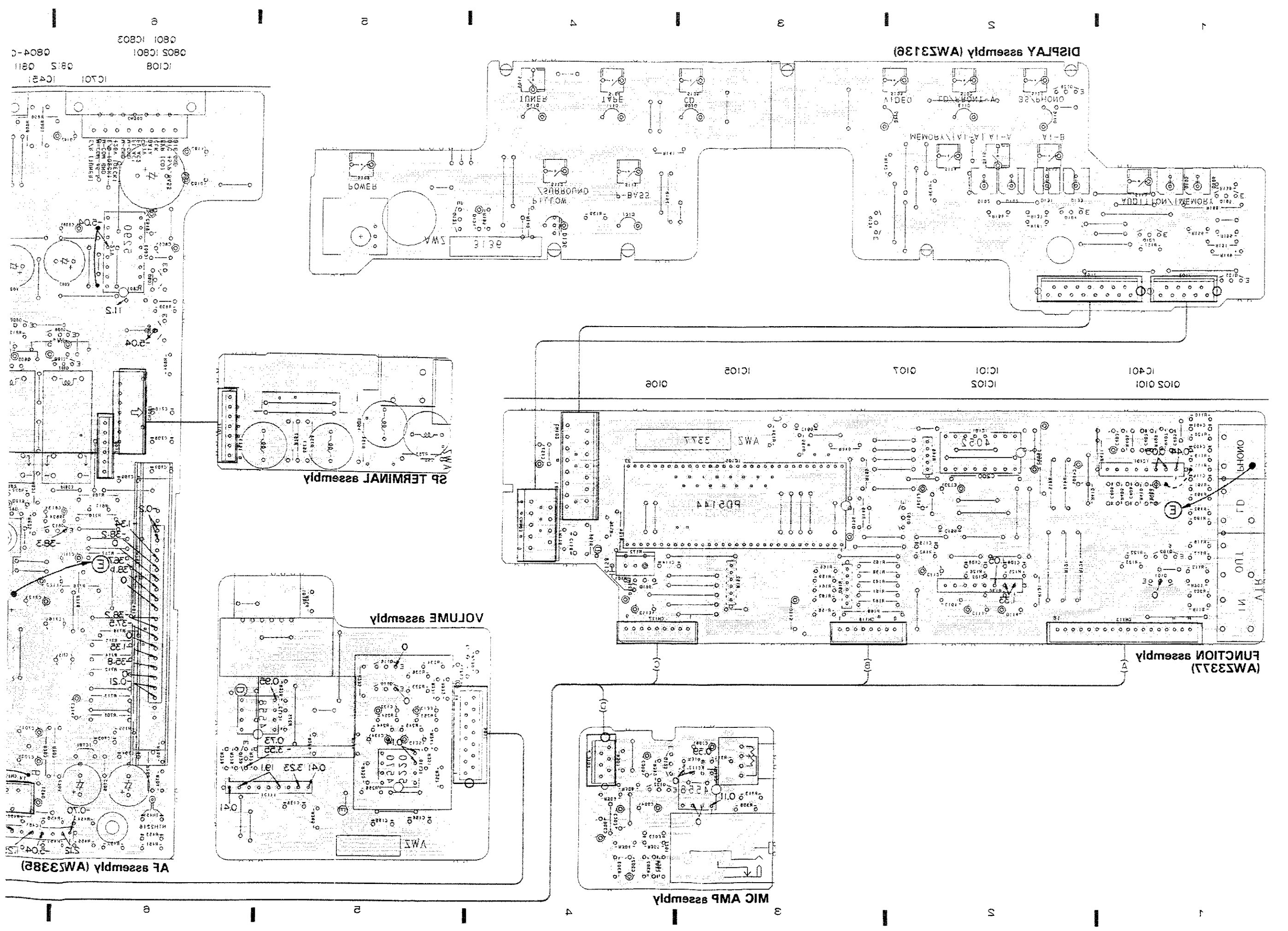

A  
B  
C  
D

IC101  
IC108  
IC109  
IC110  
IC111  
IC112  
IC113  
IC114  
IC115  
IC116  
IC117  
IC118  
IC119  
IC120  
IC121  
IC122  
IC123  
IC124  
IC125  
IC126  
IC127  
IC128  
IC129  
IC130  
IC131  
IC132  
IC133  
IC134  
IC135  
IC136  
IC137  
IC138  
IC139  
IC140  
IC141  
IC142  
IC143  
IC144  
IC145  
IC146  
IC147  
IC148  
IC149  
IC150  
IC151  
IC152  
IC153  
IC154  
IC155  
IC156  
IC157  
IC158  
IC159  
IC160  
IC161  
IC162  
IC163  
IC164  
IC165  
IC166  
IC167  
IC168  
IC169  
IC170  
IC171  
IC172  
IC173  
IC174  
IC175  
IC176  
IC177  
IC178  
IC179  
IC180  
IC181  
IC182  
IC183  
IC184  
IC185  
IC186  
IC187  
IC188  
IC189  
IC190  
IC191  
IC192  
IC193  
IC194  
IC195  
IC196  
IC197  
IC198  
IC199  
IC200

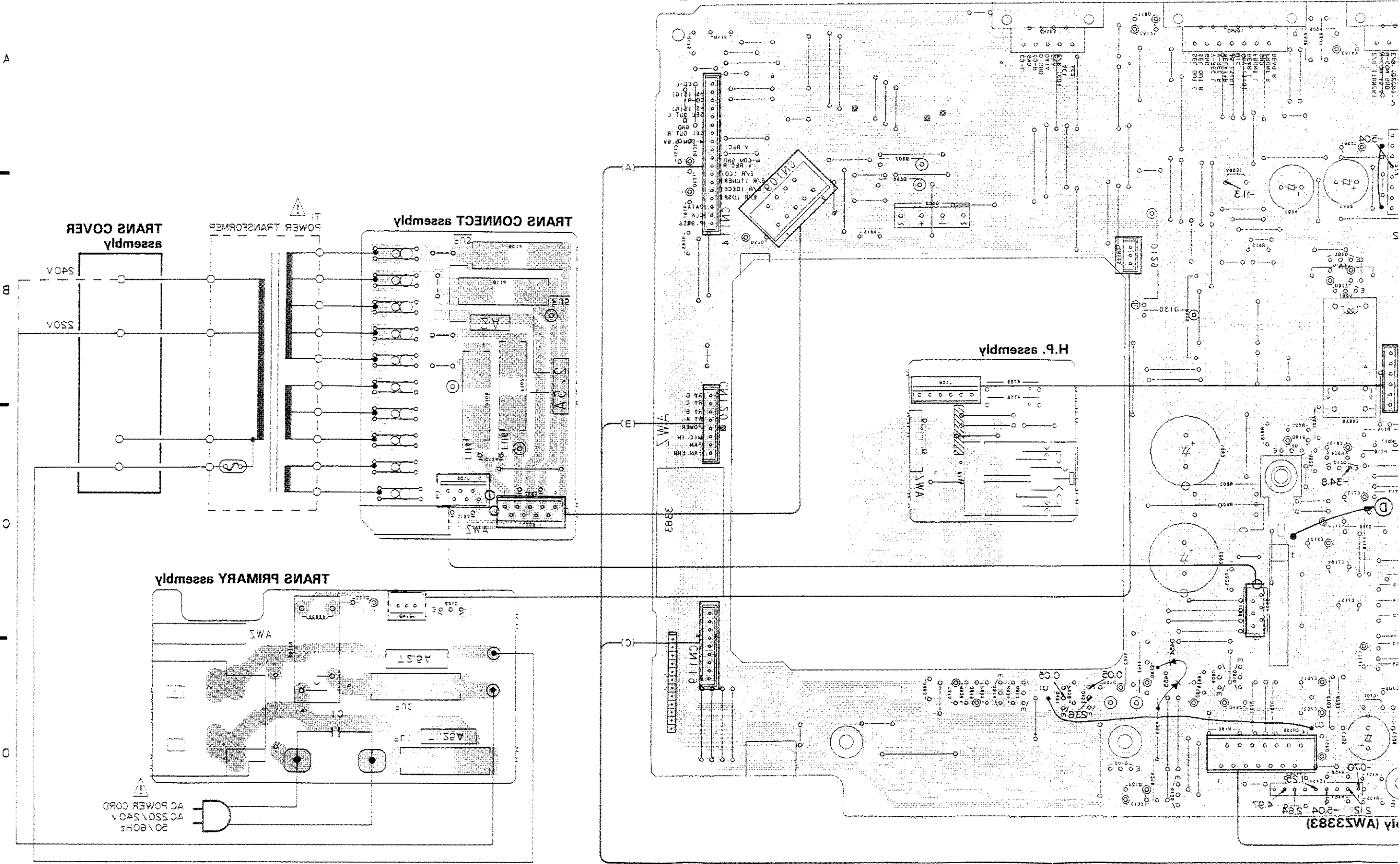

50 V 60Hz  
AC 250V 240V  
AC POWER CORD

**TRANS PRIMARY assembly**

**TRANS CONNECT assembly**

**H.P. assembly**

1/4 (AW3383)  
SIS -204 SER 431

IC401 IC421 0810 0803 0150 0108 0423 0421 0813 0814  
IC805 0815 0811 0810 0808 0150

A

B

C

D

10

11

12

8

7

6

5

10

11

12

8

7

6

5

8080 7080  
0815 0811  
0810 0808

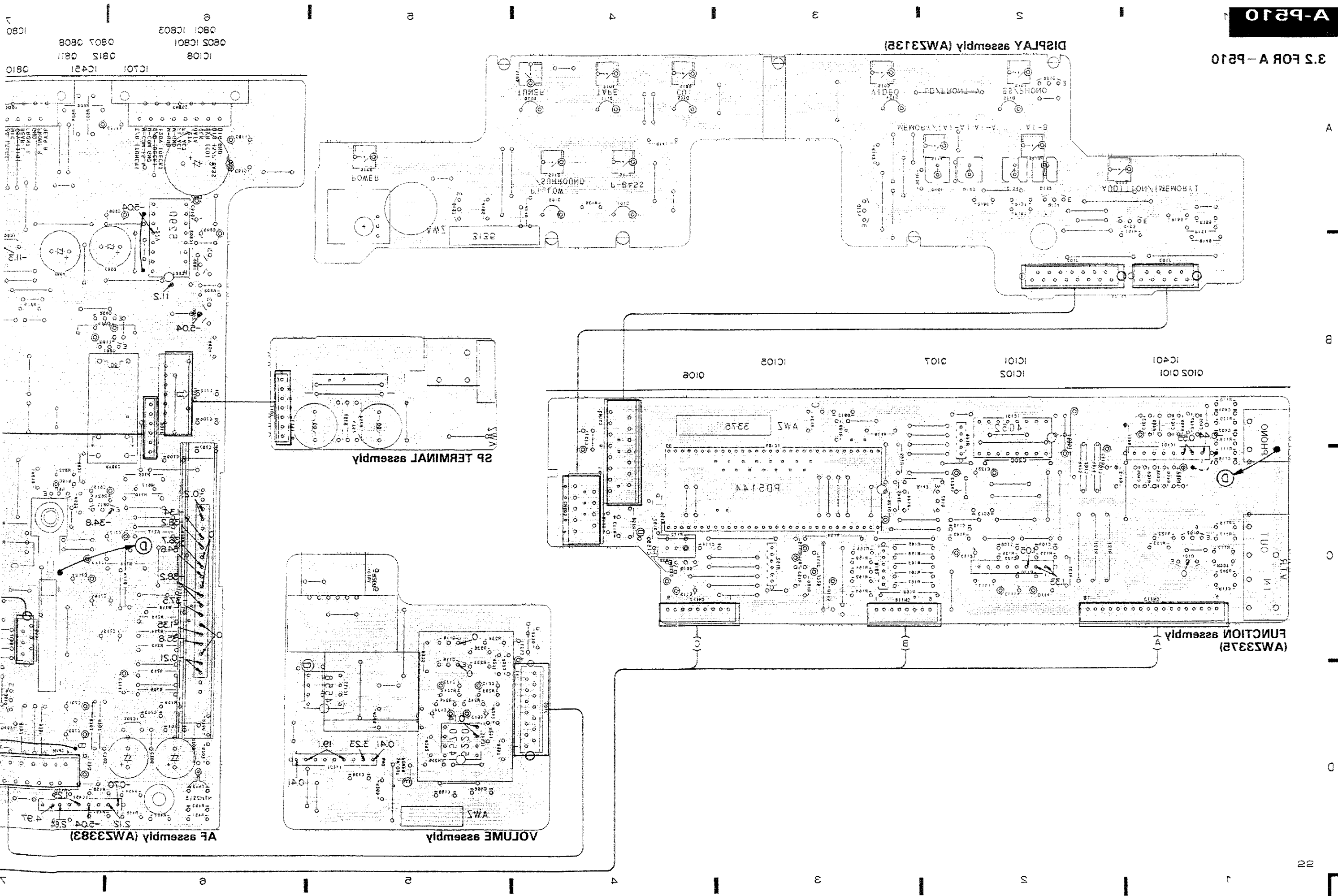

A

B

C

D

IC108 0815 0811  
IC109 0805 0801  
IC801 0801 0803

DISPLAY assembly (AWZ3135)

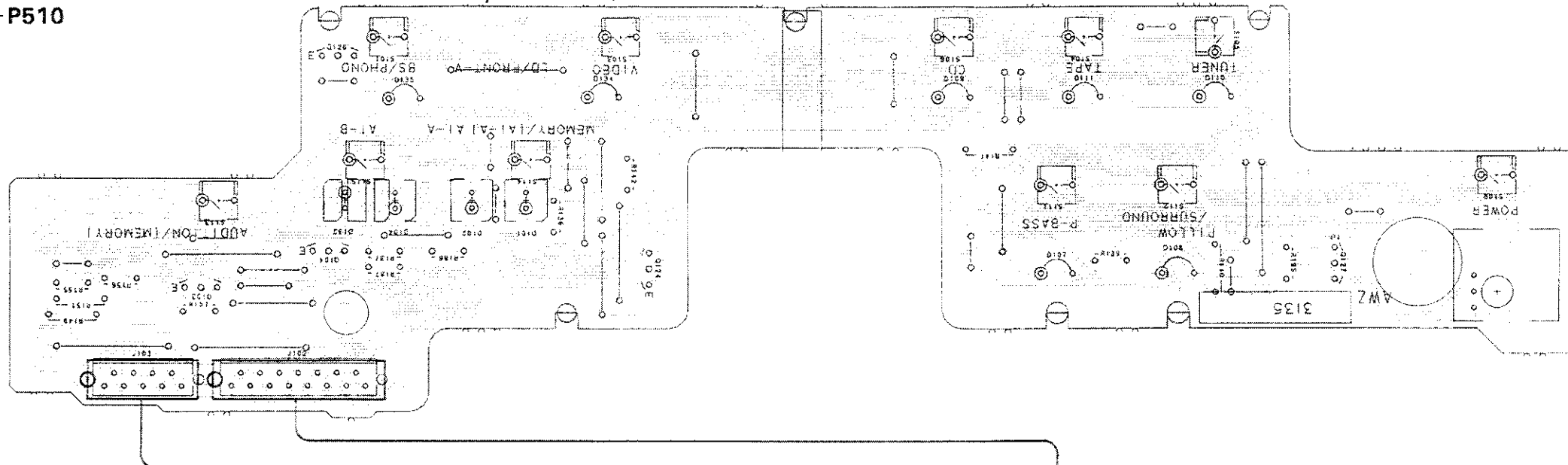

6  
Q801 IC803  
Q802 IC801  
IC108

7  
Q807 Q808  
Q812 Q811  
IC701 IC451 Q810

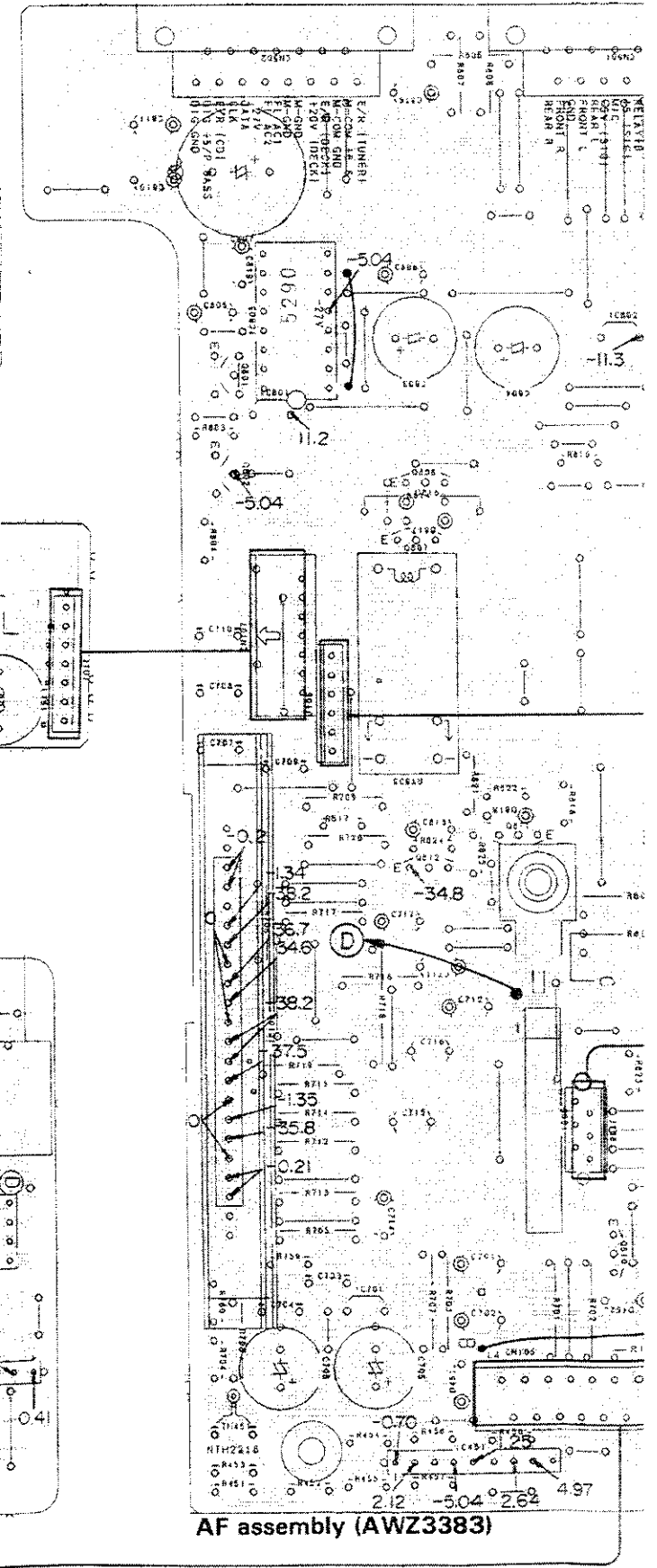

A

B

C

D

IC401  
Q102 Q101

IC101  
IC102

Q107

IC105

Q106

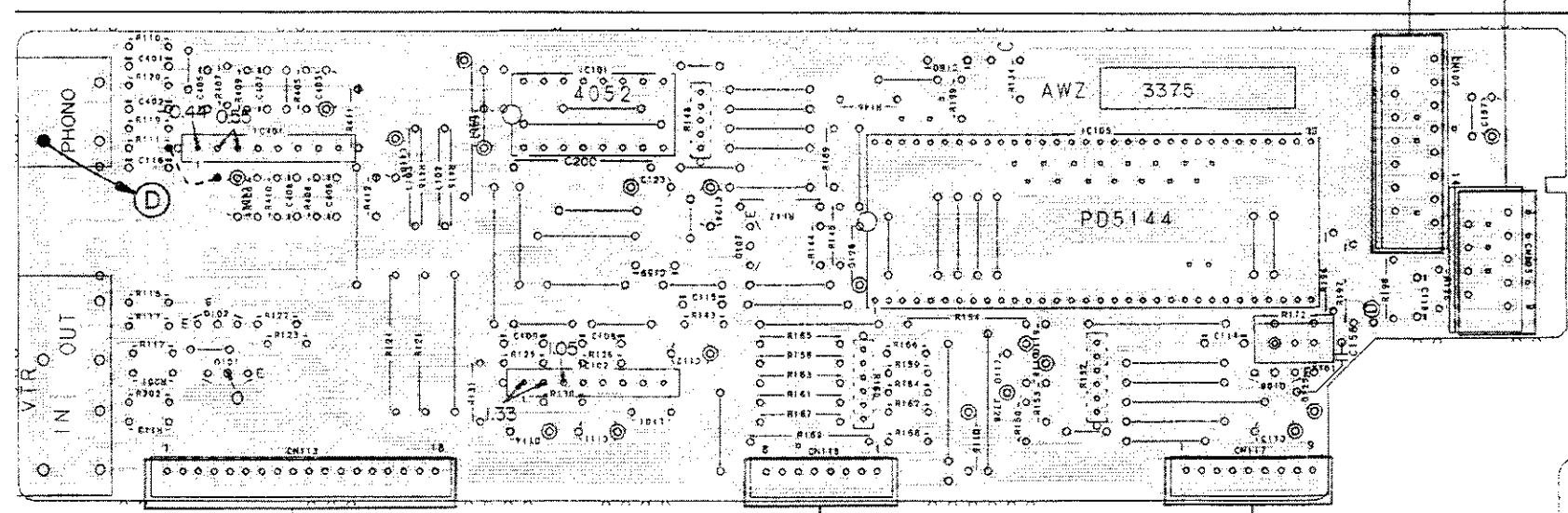

FUNCTION assembly (AWZ3375)

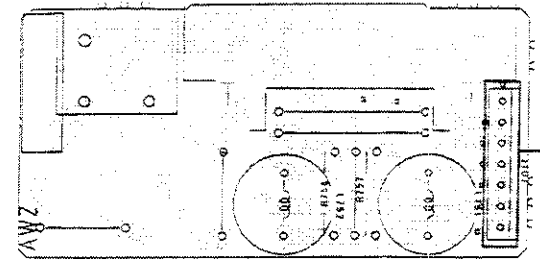

SP TERMINAL assembly

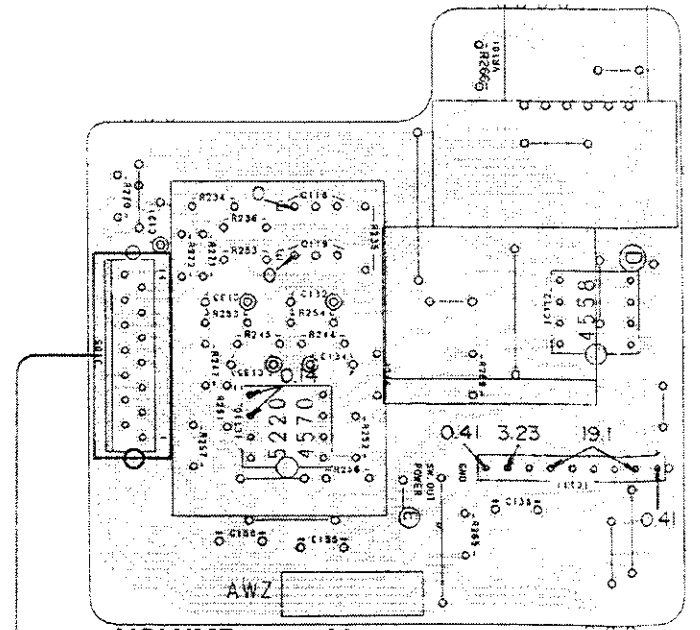

VOLUME assembly

AF assembly (AWZ3383)



Q807 Q808  
Q812 Q811

IC701 IC451 Q810 Q809 Q120 Q108 Q452 Q451 Q813 Q814

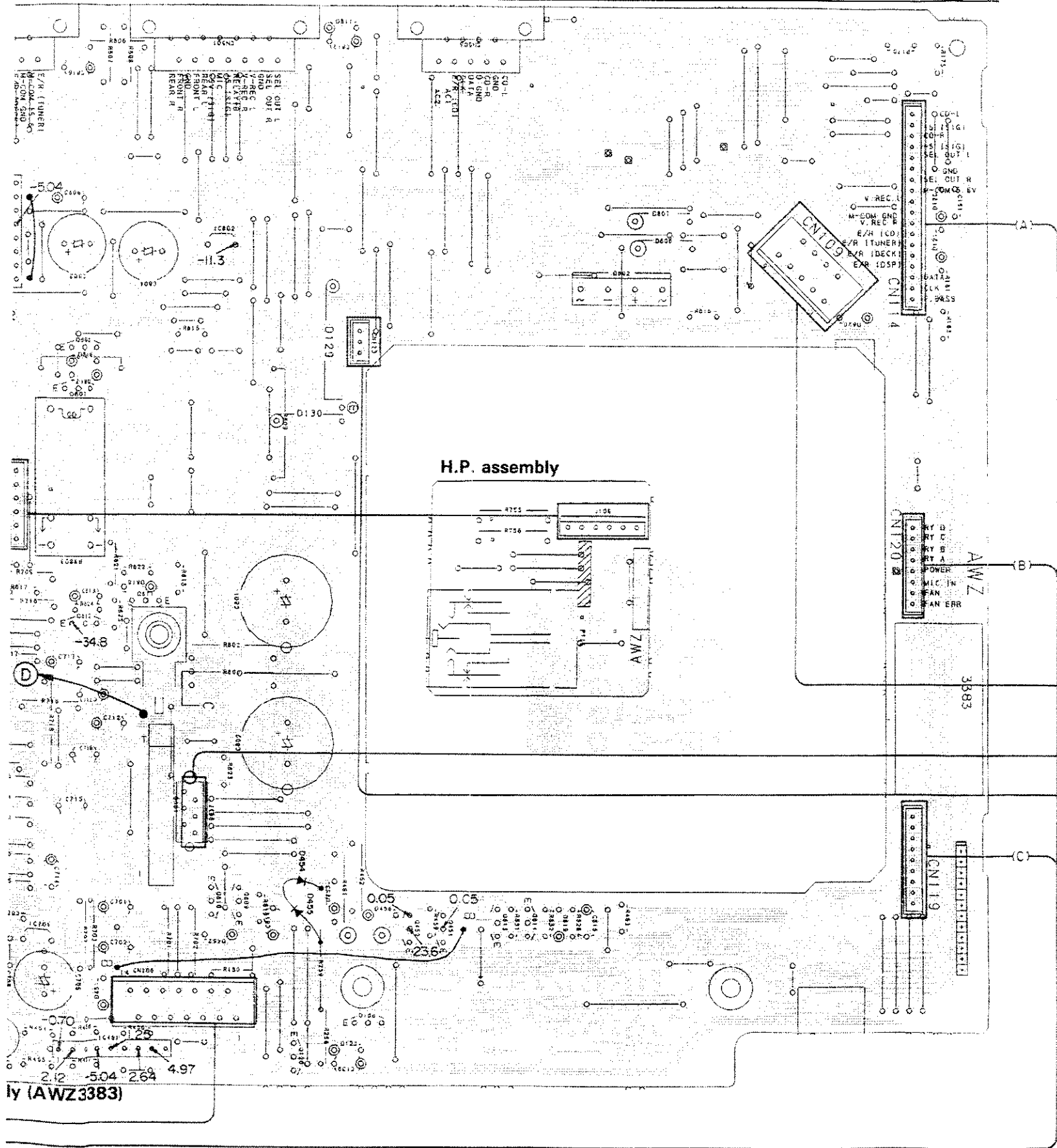

- NOTE
1. The P.C.B. connection diagram is viewed from the parts mounted side.
  2. The parts which have been mounted on the board can be replaced with those shown with the corresponding wiring symbols listed in the following Table.

P.C.B. pattern diagram indication	Corresponding part symbol	Part Name
		Transistor
		Radiator type transistor
		Diode
		Resistor
		Capacitor (Polarity)
		Capacitor (Non-polarity)

Others

P.C.B. pattern diagram indication	Part Name
IC	IC
S	Switch
RY	Relay
L	Coil
F	Filter
VR	Variable resistor or Semi-fixed resistor

3. The capacitor terminal marked with ⊖ (double circles) shows negative terminal.
4. The diode terminal marked with ⊖ (double circles) shows cathode side.
5. The transistor terminal to which E is affixed shows the emitter.

TRANS CONNECT assembly

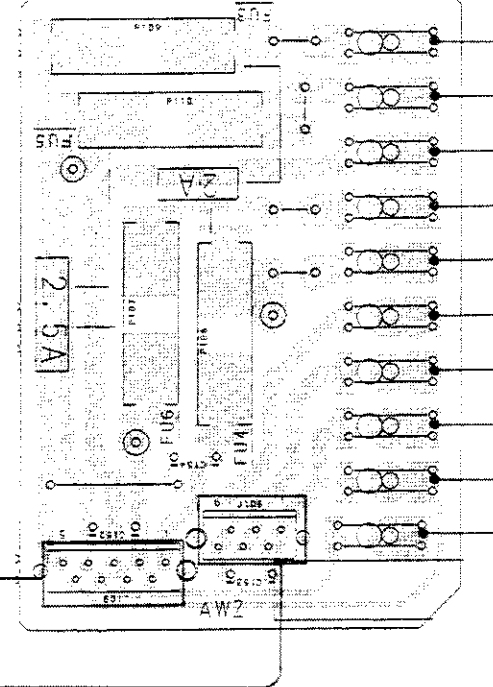

POWER TRANSFORMER

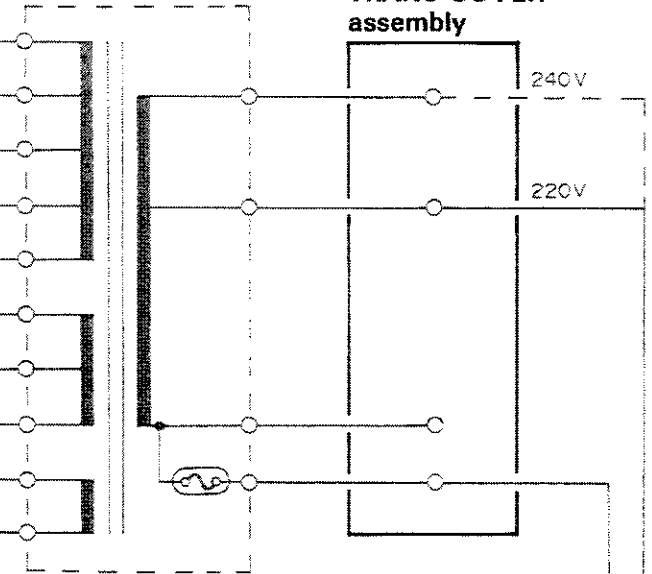

TRANS COVER assembly

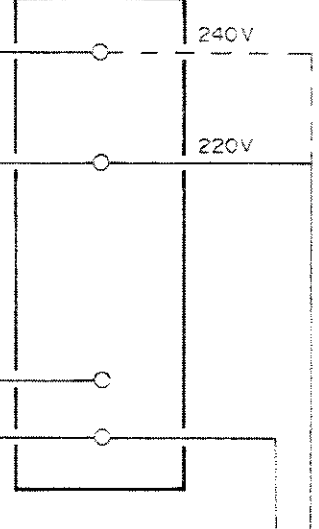

TRANS PRIMARY assembly

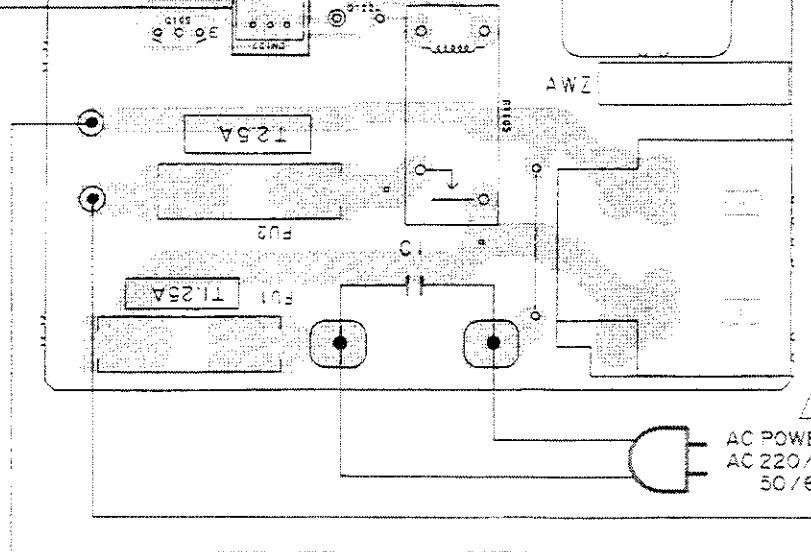

AC POWER CORD  
AC 220/240V  
50/60Hz

FUNCTION assembly (AWZ3375)

AF assembly (AWZ3383)

DISPLAY assembly (AWZ3135)

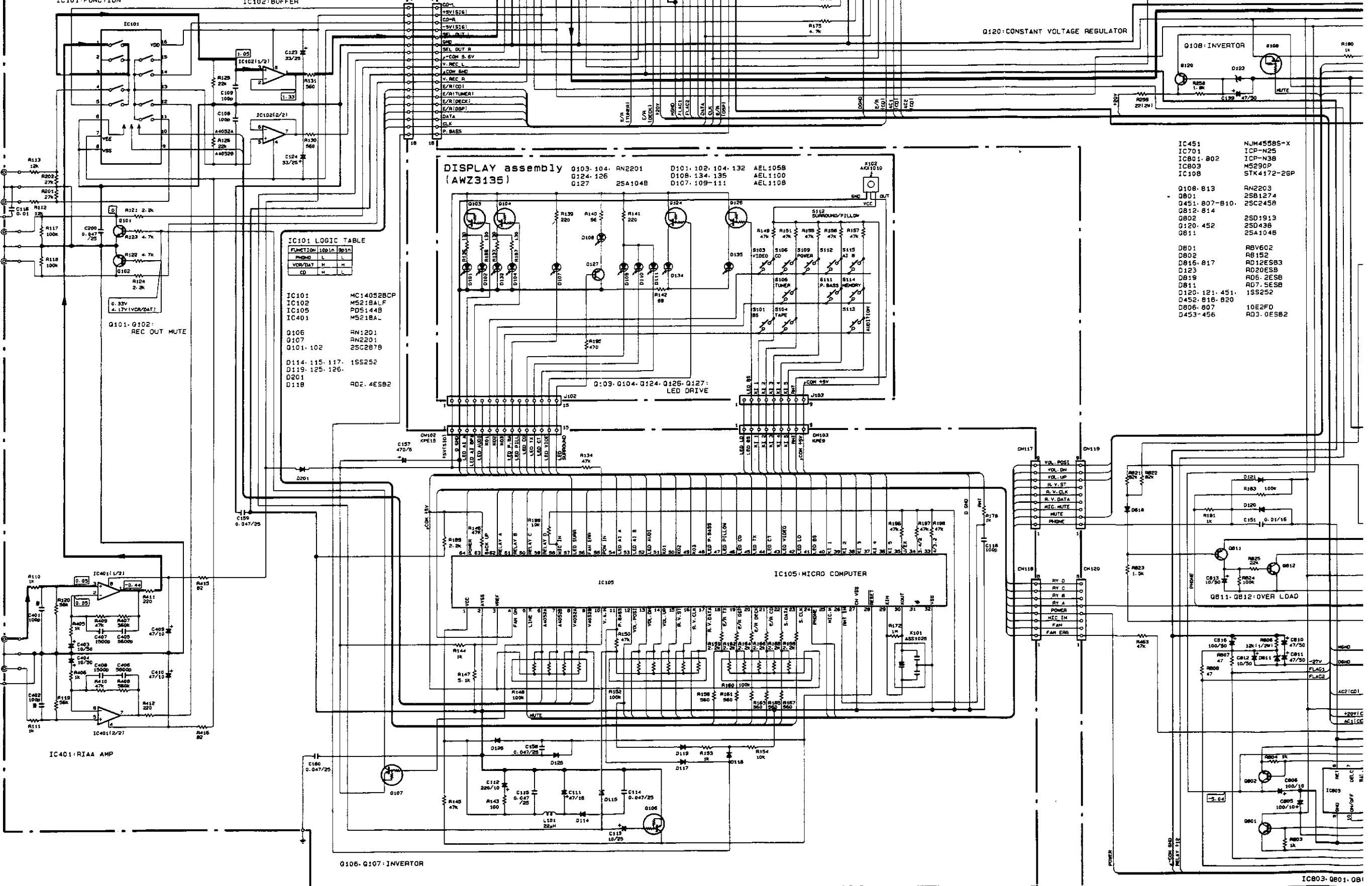

IC101 LOGIC TABLE

FUNCTION	10010	10011	10010	10011
PHONO	L	L	L	L
VCR/DAT	H	H	H	H
CD	H	L	L	H

IC101	MC14052BCP
IC102	M521BALF
IC105	PD5144B
IC401	M521BAL
Q106	RN1201
Q107	RN2201
Q101, 102	25C2878
D114, 115, 117	1S5252
D119, 125, 126	
D201	
Q118	RD2.4ESB2

- IC451 NJM45585-X
- IC701 ICP-N25
- IC801, 802 ICP-N38
- IC803 M5290P
- IC108 STK4172-2GP
  
- Q108, 813 RN2203
- Q801 25B1274
- Q451, 807-810, 25C2458
- Q812, 814 25D1913
- Q802 25D1913
- Q120, 452 25D438
- Q811 25A1048
  
- D801 RBV602
- D802 RB152
- D816, 817 RD12ESB3
- D123 RD20ESB
- D819 RD5.2ESB
- D811 RD7.5ESB
- C120, 121, 451, 155252
- Q452, 816, 820 10E2FD
- D806, 807 10E2FD
- Q453-456 RD3.0ESB2

Q106, Q107: INVERTOR

Q811, Q812: OVER LOAD

IC803, Q801, Q81



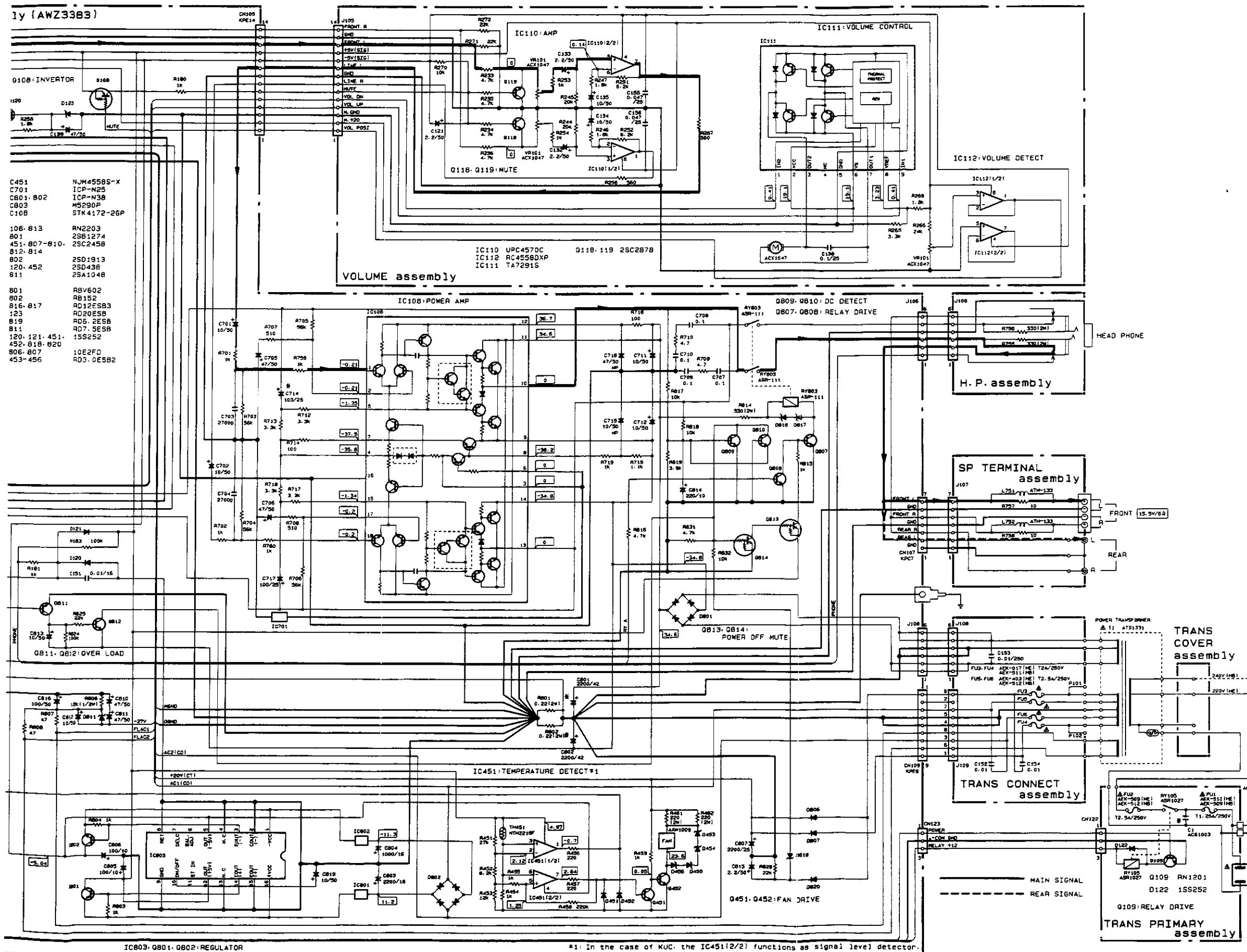

- ly (AWZ33B3)
- C451 NJM4558S-X
  - C701 1C0-N25
  - C801, 802 1C0-N38
  - C803 MS290P
  - C108 STK4172-26P
  - 106, 813 RN2203
  - 801 25B1274
  - 451, 807-810, 25C2458
  - 815, 814 25D1913
  - 802 25D438
  - 120, 452 25A1048
  - 811 25A1048
  - 801 RBV602
  - 802 RB152
  - 816, 817 RD12ESB3
  - 823 RD20ESB
  - 819 RD5, 2ESB
  - 811 RD7, 5ESB
  - 120, 121, 451, 15S252
  - 452, 818, 820 10E2FD
  - 806, 807 RD3, 0ESB2
  - 453-456

1. RESISTORS:  
Indicated in Ω, %W, %W, ±5% tolerance unless otherwise noted k:kΩ, M: MΩ, (F): ±1%, (G): ±2%, (K): ±10% (M): ±20% tolerance
  2. CAPACITORS:  
Indicated in capacity (μF)/voltage (V) unless otherwise noted p: pF  
Indication without voltage is 50V except electrolytic capacitor.
  3. VOLTAGE, CURRENT:  
□: Signal voltage at (35W + 35W 8Ω) output, DIN (1kHz)  
□: DC voltage (V) at no input signal  
Value in ( ) is DC voltage at rated power.  
◀ mA: DC current at no input signal
  4. OTHERS:  
➔: Signal route.  
⊙: Adjusting point.  
The ⚠ mark found on some component parts indicates the importance of the safety factor of the part. Therefore, when replacing, be sure to use parts of identical designation.  
\* marked capacitors and resistors have parts numbers.
- This is the basic schematic diagram, but the actual circuit may vary due to improvements in design.

- SWITCHES:
- DISPLAY assembly
- S101 PHONO
  - S103 VIDEO
  - S104 TAPE
  - S105 TUNER
  - S106 CD
  - S109 POWER
  - S111 P-BASS
  - S112 SURROUND
  - S113 MEMORY
  - S114 AI A
  - S115 AI B

- Line Voltage Selection**  
(For HE, HB and HEWZIW types)  
Line voltage can be changed with following steps.
1. Disconnect the AC power cord.
  2. Remove the Bonnet case.
  3. Change the connection of the power transformer lead wire.
  4. Stick the line voltage label on the rear panel.

Part No.	Description
AAX-193	220V label
AAX-192	240V label
---	220V
---	240V

\*1: In the case of KUC, the IC451(2/2) functions as signal level detector.

**4. PCB 's PARTS LIST**

**NOTES:**

- Parts without part number cannot be supplied.
- Parts marked by "⊙" are not always kept in stock. Their delivery time may be longer than usual or they may be unavailable.
- The Δ mark found on some component parts indicates the importance of the safety factor of the part. Therefore, when replacing, be sure to use parts of identical designation.
- When ordering resistors, first convert resistance values into code form as shown in the following examples.

Ex. 1 When there are 2 effective digits (any digit apart from 0), such as 560 ohm and 47k ohm (tolerance is shown by J = 5%, and K = 10%).

560Ω 56 × 10<sup>1</sup> 561..... RD1/4PS ⊙ ⊙ ⊙ J  
 47kΩ 47 × 10<sup>3</sup> 473..... RD1/4PS ⊙ ⊙ ⊙ J  
 0.5Ω 0R5..... RN2H ⊙ ⊙ ⊙ K  
 1Ω 010..... RS1P ⊙ ⊙ ⊙ K

Ex. 2 When there are 3 effective digits (such as in high precision metal film resistors).

5.62kΩ 562 × 10<sup>1</sup> 5621..... RN1/4SR ⊙ ⊙ ⊙ F

**4.1 FOR A - P710/HE TYPE**

Mark No.	Description	Parts No.	Mark No.	Description	Parts No.
<b>MIC AMP ASSEMBLY</b>					
<b>SEMICONDUCTORS</b>					
IC113	OP-AMP IC	RC4558DXP	D102, 103	LED	AEL1058
Q122	TRANSISTOR	RN2203	D105, 106	LED	AEL1003
Q123	TRANSISTOR	2SC2878	D107, 109	LED (RED)	AEL1108
<b>CAPACITORS</b>					
C201	CERAMIC CAPACITOR	CKDYB332K50	D110, 111	LED (RED)	AEL1108
C202	ELECTROLYTIC CAPACIT	CEJA0R1M50	D112, 113	LED	AEL1100
C203	CERAMIC CAPACITOR	CKDYB331K50	D116	LED	AEL1100
C204, 205	ELECTROLYTIC CAPACIT	CEJA100M25	D124	DIODE	1SS252
C206, 207	CERAMIC CAPACITOR	CKDYX473M25	D131, 133	LED	AEL1058
C208	ELECTROLYTIC CAPACIT	CEJA100M25	D136	LED (RED, AMBER)	AEL1101
<b>RESISTORS</b>					
VR102	VARIABLE (10k - X1)	ACS1025	<b>SWITCHES</b>		
Other resistors		RD1/8PM ⊙ ⊙ ⊙ J	S101 - 106	SWITCH	ASG1034
			S109 - 115	SWITCH	ASG1034
<b>OTHERS</b>					
JACK (MIC)		AKN1017	<b>RESISTORS</b>		
			All resistors		
			RD1/8PM ⊙ ⊙ ⊙ J		
<b>⊙ DISPLAY ASSEMBLY (AWZ3136)</b>					
<b>SEMICONDUCTORS</b>					
Q103 - 105	TRANSISTOR	RN2201	<b>OTHERS</b>		
Q124 - 126	TRANSISTOR	RN2201	REMOTE RECEIVER UNIT		
Q127	TRANSISTOR	2SA1048	AXX1010		
<b>SP TERMINAL ASSEMBLY</b>					
<b>COILS</b>					
			L751 - 754	COIL	ATH - 133
<b>RESISTORS</b>					
			All resistors		
			RD1/4PMFL100J		
<b>OTHERS</b>					
			PIN JACK (2P)		
			AKB1146		
			SPEAKER TERMINAL 4P		
			AKE1026		

Mark No.	Description	Parts No.	Mark No.	Description	Parts No.
<b>TRANS CONNECT ASSEMBLY</b>					
<b>CAPACITORS</b>					
C152	MYLOR FILM CAPACITOR	CQMA103K50	CN102	CONNECTOR (15P)	KPE15
C153	MYLOR FILM CAPACITOR	CQMA103K250	CN103	CONNECTOR (9P)	KPE9
C154	MYLOR FILM CAPACITOR	CQMA103K50	PIN JACK (4P)		AKB1101
			PIN JACK (4P)		AKB1124
			X101	CERAMIC RESONATOR	ASS1025
<b>⊙ FUNCTION ASSEMBLY (AWZ3377)</b>					
<b>SEMICONDUCTORS</b>					
IC101	LOGIC IC	MC14052BCP	<b>OTHERS</b>		
IC102	OP-AMP IC	M5218ALF	R755, 756	METAL OXIDE RESISTOR	RS2LMF331J
IC105	AMP CONTROL μ-COM.	PD5144B	<b>OTHERS</b>		
IC401	OP-AMP IC	M5218AL	CN	JACK	AKN1025
Q101, 102	TRANSISTOR	2SC2878	<b>⊙ AF ASSEMBLY (AWZ3385)</b>		
Q106	TRANSISTOR	RN1201	<b>SEMICONDUCTORS</b>		
Q107	TRANSISTOR	RN2201	IC108	AUDIO IC	STK4172-2GP
D114, 115	DIODE	1SS252	IC451	OP-AMP IC	NJM4558S-X
D125, 126	DIODE	1SS252	IC701	IC PROTECTOR	ICP-N25
<b>COIL</b>					
L101	AXIAL INDUCTOR	LAU220K	IC801, 802	IC PROTECTOR	ICP-N38
<b>CAPACITORS</b>					
C108, 109	CERAMIC CAPACITOR	CCDSL101J50	IC803	REGURATOR IC	M5290P
C111	ELECTROLYTIC CAPACIT	CEJA470M16	Q108	TRANSISTOR	RN2203
C112	ELECTR. CAPACITOR	CEAS221M10	Q120	TRANSISTOR	2SD438
C113	ELECTROLYTIC CAPACIT	CEJA100M25	Q451	TRANSISTOR	2SC2458
C114 - 116	CERAMIC CAPACITOR	CKDYX473M25	Q452	TRANSISTOR	2SD438
C118	CERAMIC CAPACITOR	CCDSL101J50	Q801	TRANSISTOR	2SB1274
C123, 124	ELECTROLYTIC CAPACIT	CEJA330M25	Q802	TRANSISTOR	2SD1913
C157	ELECTROLYTIC CAPACIT	CEAS471M6	Q804 - 810	TRANSISTOR	2SC2458
C158 - 160	CERAMIC CAPACITOR	CKDYX473M25	Q811	TRANSISTOR	2SA1048
C200	CERAMIC CAPACITOR	CKDYX473M25	Q812	TRANSISTOR	2SC2458
C401, 402	CERAMIC CAPACITOR	ACG1017	Q813	TRANSISTOR	RN2203
C403, 404	ELECTR. CAPACITOR	CEAS100M50	Q814	TRANSISTOR	2SC2458
C405, 406	CERAMIC CAPACITOR	CKDYB562K50	D120, 121	DIODE	1SS252
C407, 408	CERAMIC CAPACITOR	CKDYB152K50	D123	ZENER DIODE	RD20ESB
C409, 410	ELECTR. CAPACITOR	CEAS470M10	D201	DIODE	1SS252
<b>RESISTORS</b>					
R148	RESISTOR ARRAY (10k)	RA4T104J	D451, 452	DIODE	1SS252
R152	RESISTOR ARRAY (100k)	RA5T104J	D453 - 456	ZENER DIODE	RD3.0ESB2
R160	RESISTOR ARRAY (100k)	RA5T104J	D801	DIODE	RBV602
Other resistors		RD1/8PM ⊙ ⊙ ⊙ J	D802	DIODE	RB152
			D806, 807	DIODE	10E2FD
			D811	ZENER DIODE	RD7.5ESB
			D812, 813	ZENER DIODE	RD6.2ESB3
			D814 - 817	ZENER DIODE	RD12ESB3
			D818	DIODE	1SS252
			D819	ZENER DIODE	RD6.2ESB
			D820	DIODE	1SS252

Mark No.	Description	Parts No.
<b>RELAIES</b>		
RY801	RELAY	ASR1027
RY802, 803	RELAY	ASR-111
<b>CAPACITORS</b>		
C139	ELECTR.CAPACITOR	CEAS470M50
C151	CERAMIC CAPACITOR	CKPUYY103M16
C701, 702	ELECTR.CAPACITOR	CEHAQ100M50
C703, 704	CERAMIC CAPACITOR	CKDYB272K50
C705, 706	ELECTROLYTIC CAPACIT	CEHAQ470M50
C707-710	MYLOR FILM CAPACITOR	CQMA104K50
C711, 712	ELECTROLYTIC CAPACIT	CEHAQ100M50
C714	ELECTROLYTIC CAPACIT	CEHAQ101M25
C715	ELECTR.CAPACITOR	ACH1141
C716	ELECTROLYTIC CAPACIT	ACH1143
C717	ELECTROLYTIC CAPACIT	CEHAQ101M25
C801, 802	ELECTROLYTIC CAPACIT	ACH1140
C803	ELECTR.CAPACITOR	CEAS222M16
C804	ELECTR.CAPACITOR	CEAS102M16
C805, 806	ELECTROLYTIC CAPACIT	CEHAQ101M10
C807	ELECTROLYTIC CAPACIT	CEHAQ222M25
C810, 811	ELECTROLYTIC CAPACIT	CEHAQ470M50
C812	ELECTR.CAPACITOR	CEAS100M50
C813	ELECTROLYTIC CAPACIT	CEHAQ100M50
C814	ELECTR.CAPACITOR	CEAS221M10
C815	ELECTR.CAPACITOR	CEAS2R2M50
C816	ELECTR.CAPACITOR	CEAS101M50
C819	ELECTR.CAPACITOR	CEAS100M50
<b>RESISTORS</b>		
R258	CARBON FILM RESISTOR	RD1/4PM182J
R259	METAL OXIDE RESISTOR	RS2LMF220J
R451	METALFILM RESISTOR	RN1/4PC2702F
R452	METALFILM RESISTOR	RN1/4PC8201F
R453	METALFILM RESISTOR	RN1/4PC1202F
R454	METALFILM RESISTOR	RN1/4PC1001F
R461, 462	METAL OXIDE RESISTOR	RS2LMF221J

Mark No.	Description	Parts No.
R705, 706	CARBON FILM RESISTOR	RD1/4PM563J
R707, 708	CARBON FILM RESISTOR	RD1/4PM511J
R709, 710	CARBON FILM RESISTOR	RD1/4PMFL4R7J
R712, 713	CARBON FILM RESISTOR	RD1/2PM332J
R714	CARBON FILM RESISTOR	RD1/4PMFL101J
R715	CARBON FILM RESISTOR	RD1/4PM112J
R716	CARBON FILM RESISTOR	RD1/4PMFL101J
R717, 718	CARBON FILM RESISTOR	RD1/2PM332J
R719	CARBON FILM RESISTOR	RD1/4PMFL102J
R801, 802	METAL OXIDE RESISTOR	RS2LMFR22J
R806	CARBON FILM RESISTOR	RD1/2PMFL123J
R807, 808	FUSIBLE RESISTOR	RFA1/4PS470J
R809	METAL OXIDE RESISTOR	RS3LMF471J
R811	METAL OXIDE RESISTOR	RS2LMF471J
R814	METAL OXIDE RESISTOR	RS2LMF471J
	Other resistors	RD1/8PM□□□J
<b>OTHERS</b>		
CN104	CONNECTOR (6P)	KPE6
CN105	CONNECTOR (14P)	KPE14
CN107	CONNECTOR (7P)	KPC7
CN109	CONNECTOR (9P)	KPE9
CN501	SOCKET (14P)	AKP1074
CN502	SOCKET (15P)	AKP1075
CN503	SOCKET (9P)	AKP1072
TH451	THERMISTOR	NTH2218F

#### TRANS PRIMARY ASSEMBLY

##### SEMICONDUCTORS

Q109	TRANSISTOR	RN1201
D122	DIODE	1SS252

##### RELAY

RY105	RELAY	ASR1027
-------	-------	---------

##### OTHERS

△	AC SOCKET (1-P)	AKP1034
---	-----------------	---------

Mark No.	Description	Parts No.
<b>VOLUME ASSEMBLY</b>		
<b>SEMICONDUCTORS</b>		
IC110	IC	UPC4570C
IC111	MECHANISM DRIVER IC	TA7291S
IC112	OP-AMP IC	RC4558DXP
Q118, 119	TRANSISTOR	2SC2878
Q128	TRANSISTOR	2SC2878
<b>CAPACITORS</b>		
C121	ELECTROLYTIC CAPACIT	CEHAQ2R2M50
C132, 133	ELECTROLYTIC CAPACIT	CEHAQ2R2M50
C134, 135	ELECTR.CAPACITOR	CEHAQ100M50
C138	CERAMIC CAPACITOR	CKDYX104M25
C155, 156	CERAMIC CAPACITOR	CKDYX473M25
<b>RESISTORS</b>		
VR101	VR	ACX1047
	Other resistors	RD1/8PM□□□J

#### TRANS COVER ASSEMBLY

No parts are supplied with the TRANS COVER Assembly.

#### 4.2 FOR A-P510/HE TYPE

Mark No.	Description	Parts No.
<b>◎ DISPLAY ASSEMBLY (AWZ3135)</b>		
<b>SEMICONDUCTORS</b>		
Q103, 104	TRANSISTOR	RN2201
Q124, 126	TRANSISTOR	RN2201
Q127	TRANSISTOR	2SA1048
D101, 102	LED	AEL1058
D104	LED	AEL1058
D107	LED (RED)	AEL1108
D108	LED	AEL1100
D109-111	LED (RED)	AEL1108
D132	LED	AEL1058
D134, 135	LED	AEL1100
<b>SWITCHES</b>		
S101	SWITCH	ASG1034
S103-106	SWITCH	ASG1034
S109	SWITCH	ASG1034
S111-115	SWITCH	ASG1034
<b>RESISTORS</b>		
R186, 187	CARBON FILM RESISTOR	RD1/4PM131J
	Other resistors	RD1/8PM□□□J
<b>OTHERS</b>		
	REMOTE RECEIVER UNIT	AXX1010
<b>SP TERMINAL ASSEMBLY</b>		
<b>COILS</b>		
L751, 752	COIL	ATH-133
<b>RESISTORS</b>		
R757, 758	CARBON FILM RESISTOR	RD1/4PMFL100J
<b>OTHERS</b>		
	PIN JACK (2P)	AKB1146
	SPEAKER TERMINAL 4-P	AKE1026
<b>TRANS CONNECT ASSEMBLY</b>		
<b>CAPACITORS</b>		
C152	MYLOR FILM CAPACITOR	CQMA103K50
C153	MYLOR FILM CAPACITOR	CQMA103K250
C154	MYLOR FILM CAPACITOR	CQMA103K50

## 4. PCB 's PARTS LIST

### NOTES:

- Parts without part number cannot be supplied.
- Parts marked by "⊙" are not always kept in stock. Their delivery time may be longer than usual or they may be unavailable.
- The  $\Delta$  mark found on some component parts indicates the importance of the safety factor of the part. Therefore, when replacing, be sure to use parts of identical designation.
- When ordering resistors, first convert resistance values into code form as shown in the following examples.

Ex. 1 When there are 2 effective digits (any digit apart from 0), such as 560 ohm and 47k ohm (tolerance is shown by J = 5%, and K = 10%).

560 $\Omega$	$56 \times 10^1$	561.....	RD1/4PS	$\square$	$\square$	$\square$	J
47k $\Omega$	$47 \times 10^3$	473.....	RD1/4PS	$\square$	$\square$	$\square$	J
0.5 $\Omega$	0R5.....		RN2H	$\square$	$\square$	$\square$	K
1 $\Omega$	010.....		RS1P	$\square$	$\square$	$\square$	K

Ex. 2 When there are 3 effective digits (such as in high precision metal film resistors).

5.62k $\Omega$	$562 \times 10^1$	5621.....	RN1/4SR	$\square$	$\square$	$\square$	F
----------------	-------------------	-----------	---------	-----------	-----------	-----------	---

### 4.1 FOR A - P710/HE TYPE

Mark No.	Description	Parts No.	Mark No.	Description	Parts No.
<b>MIC AMP ASSEMBLY</b>			D102, 103	LED	AEL1058
<b>SEMICONDUCTORS</b>			D105, 106	LED	AEL1003
IC113	OP-AMP IC	RC4558DXP	D107, 109	LED (RED)	AEL1108
Q122	TRANSISTOR	RN2203	D110, 111	LED (RED)	AEL1108
Q123	TRANSISTOR	2SC2878	D112, 113	LED	AEL1100
<b>CAPACITORS</b>			D116	LED	AEL1100
C201	CERAMIC CAPACITOR	CKDYB332K50	D124	DIODE	1SS252
C202	ELECTROLYTIC CAPACIT	CEJA0R1M50	D131, 133	LED	AEL1058
C203	CERAMIC CAPACITOR	CKDYB331K50	D136	LED (RED, AMBER)	AEL1101
C204, 205	ELECTROLYTIC CAPACIT	CEJA100M25	<b>SWITCHES</b>		
C206, 207	CERAMIC CAPACITOR	CKDYX473M25	S101-106	SWITCH	ASG1034
C208	ELECTROLYTIC CAPACIT	CEJA100M25	S109-115	SWITCH	ASG1034
<b>RESISTORS</b>			<b>RESISTORS</b>		
VR102	VARIABLE (10k-X1)	ACS1025	All resistors RD1/8PM□□□□		
Other resistors RD1/8PM□□□□			<b>OTHERS</b>		
<b>OTHERS</b>			REMOTE RECEIVER UNIT AX1010		
JACK (MIC) AKN1017			<b>SP TERMINAL ASSEMBLY</b>		
<b>⊙ DISPLAY ASSEMBLY (AWZ3136)</b>			<b>COILS</b>		
<b>SEMICONDUCTORS</b>			L751-754	COIL	ATF-133
Q103-105	TRANSISTOR	RN2201	<b>RESISTORS</b>		
Q124-126	TRANSISTOR	RN2201	All resistors RD1/4PMFL100J		
Q127	TRANSISTOR	2SA1048	<b>OTHERS</b>		
			PIN JACK (2P) AB1146		
			SPEAKER TERMINAL 4P AE1026		

Mark No.	Description	Parts No.
<b>TRANS CONNECT ASSEMBLY</b>		
<b>CAPACITORS</b>		
C152	MYLOR FILM CAPACITOR	CQMA103K50
C153	MYLOR FILM CAPACITOR	CQMA103K250
C154	MYLOR FILM CAPACITOR	CQMA103K50

© FUNCTION ASSEMBLY (AWZ3377)

SEMICONDUCTORS

IC101	LOGIC IC	MC14052BCP
IC102	OP-AMP IC	M5218ALF
IC105	AMP CONTROL μ-COM.	PD5144B
IC401	OP-AMP IC	M5218AL
Q101, 102	TRANSISTOR	2SC2878
Q106	TRANSISTOR	RN1201
Q107	TRANSISTOR	RN2201
D114, 115	DIODE	1SS252
D125, 126	DIODE	1SS252

COIL

L101	AXIAL INDUCTOR	LAU220K
------	----------------	---------

CAPACITORS

C108, 109	CERAMIC CAPACITOR	CCDSL101J50
C111	ELECTROLYTIC CAPACIT	CEJA470M16
C112	ELECTR.CAPACITOR	CEAS221M10
C113	ELECTROLYTIC CAPACIT	CEJA100M25
C114-116	CERAMIC CAPACITOR	CKDYX473M25
C118	CERAMIC CAPACITOR	CCDSL101J50
C123, 124	ELECTROLYTIC CAPACIT	CEJA330M25
C157	ELECTROLYTIC CAPACIT	CEAS471M6
C158-160	CERAMIC CAPACITOR	CKDYX473M25
C200	CERAMIC CAPACITOR	CKDYX473M25
C401, 402	CERAMIC CAPACITOR	ACG1017
C403, 404	ELECTR.CAPACITOR	CEAS100M50
C405, 406	CERAMIC CAPACITOR	CKDYB562K50
C407, 408	CERAMIC CAPACITOR	CKDYB152K50
C409, 410	ELECTR.CAPACITOR	CEAS470M10

RESISTORS

R148	RESISTOR ARRAY (10k)	RA4T104J
R152	RESISTOR ARRAY (100k)	RA5T104J
R160	RESISTOR ARRAY (100k)	RA5T104J
	Other resistors	RD1/8PM□□□J

Mark No.	Description	Parts No.
<b>OTHERS</b>		
CN102	CONNECTOR (15P)	KPE15
CN103	CONNECTOR (9P)	KPE9
	PIN JACK (4P)	AKB1101
	PIN JACK (4P)	AKB1124
X101	CERAMIC RESONATOR	ASS1025

H.P. ASSEMBLY

RESISTORS

R755, 756	METAL OXIDE RESISTOR	RS2LMF331J
-----------	----------------------	------------

OTHERS

CN	JACK	AKN1025
----	------	---------

© AF ASSEMBLY (AWZ3385)

SEMICONDUCTORS

IC108	AUDIO IC	STK4172-2GP
IC451	OP-AMP IC	NJM4558S-X
IC701	IC PROTECTOR	ICP-N25
IC801, 802	IC PROTECTOR	ICP-N38
IC803	REGURATOR IC	M5290P
Q108	TRANSISTOR	RN2203
Q120	TRANSISTOR	2SD438
Q451	TRANSISTOR	2SC2458
Q452	TRANSISTOR	2SD438
Q801	TRANSISTOR	2SB1274
Q802	TRANSISTOR	2SD1913
Q804-810	TRANSISTOR	2SC2458
Q811	TRANSISTOR	2SA1048
Q812	TRANSISTOR	2SC2458
Q813	TRANSISTOR	RN2203
Q814	TRANSISTOR	2SC2458
D120, 121	DIODE	1SS252
D123	ZENER DIODE	RD20ESB
D201	DIODE	1SS252
D451, 452	DIODE	1SS252
D453-456	ZENER DIODE	RD3.0ESB2
D801	DIODE	RBV602
D802	DIODE	RB152
D806, 807	DIODE	10E2FD
D811	ZENER DIODE	RD7.5ESB
D812, 813	ZENER DIODE	RD6.2ESB3
D814-817	ZENER DIODE	RD12ESB3
D818	DIODE	1SS252
D819	ZENER DIODE	RD6.2ESB
D820	DIODE	1SS252

Mark No.	Description	Parts No.	Mark No.	Description	Parts No.
<b>RELAIIES</b>			R705, 706	CARBON FILM RESISTOR	RD1/4PM563J
RY801	RELAY	ASR1027	R707, 708	CARBON FILM RESISTOR	RD1/4PM511J
RY802, 803	RELAY	ASR-111	R709, 710	CARBON FILM RESISTOR	RD1/4PMFLAR7J
<b>CAPACITORS</b>			R712, 713	CARBON FILM RESISTOR	RD1/2PM332J
C139	ELECTR.CAPACITOR	CEAS470M50	R714	CARBON FILM RESISTOR	RD1/4PMFL101J
C151	CERAMIC CAPACITOR	CKPUYY103M16	R715	CARBON FILM RESISTOR	RD1/4PM112J
C701, 702	ELECTR.CAPACITOR	CEHAQ100M50	R716	CARBON FILM RESISTOR	RD1/4PMFL101J
C703, 704	CERAMIC CAPACITOR	CKDYB272K50	R717, 718	CARBON FILM RESISTOR	RD1/2PM332J
C705, 706	ELECTROLYTIC CAPACIT	CEHAQ470M50	R719	CARBON FILM RESISTOR	RD1/4PMFL102J
C707-710	MYLOR FILM CAPACITOR	CQMA104K50	R801, 802	METAL OXIDE RESISTOR	RS2LMFR22J
C711, 712	ELECTROLYTIC CAPACIT	CEHAQ100M50	R806	CARBON FILM RESISTOR	RD1/2PMFL123J
C714	ELECTROLYTIC CAPACIT	CEHAQ101M25	R807, 808	FUSIBLE RESISTOR	RFA1/4PS470J
C715	ELECTR.CAPACITOR	ACH1141	R809	METAL OXIDE RESISTOR	RS3LMF471J
C716	ELECTROLYTIC CAPACIT	ACH1143	R811	METAL OXIDE RESISTOR	RS2LMF471J
C717	ELECTROLYTIC CAPACIT	CEHAQ101M25	R814	METAL OXIDE RESISTOR	RS2LMF471J
C801, 802	ELECTROLYTIC CAPACIT	ACH1140		Other resistors	RD1/8PM□□□□J
C803	ELECTR.CAPACITOR	CEAS222M16	<b>OTHERS</b>		
C804	ELECTR.CAPACITOR	CEAS102M16	CN104	CONNECTOR (6P)	KPE6
C805, 806	ELECTROLYTIC CAPACIT	CEHAQ101M10	CN105	CONNECTOR (14P)	KPE14
C807	ELECTROLYTIC CAPACIT	CEHAQ222M25	CN107	CONNECTOR (7P)	KPC7
C810, 811	ELECTROLYTIC CAPACIT	CEHAQ470M50	CN109	CONNECTOR (9P)	KPE9
C812	ELECTR.CAPACITOR	CEAS100M50	CN501	SOCKET (14P)	AKP1074
C813	ELECTROLYTIC CAPACIT	CEHAQ100M50	CN502	SOCKET (15P)	AKP1075
C814	ELECTR.CAPACITOR	CEAS221M10	CN503	SOCKET (9P)	AKP1072
C815	ELECTR.CAPACITOR	CEAS2R2M50	TH451	THERMISTOR	NTH2218F
C816	ELECTR.CAPACITOR	CEAS101M50	<b>TRANS PRIMARY ASSEMBLY</b>		
C819	ELECTR.CAPACITOR	CEAS100M50	<b>SEMICONDUCTORS</b>		
<b>RESISTORS</b>			Q109	TRANSISTOR	RN1201
R258	CARBON FILM RESISTOR	RD1/4PM182J	D122	DIODE	1SS252
R259	METAL OXIDE RESISTOR	RS2LMF220J	<b>RELAY</b>		
R451	METALFILM RESISTER	RN1/4PC2702F	RY105	RELAY	ASR1027
R452	METALFILM RESISTER	RN1/4PC8201F	<b>OTHERS</b>		
R453	METALFILM RESISTER	RN1/4PC1202F	△	AC SOCKET (1-P)	AKP1034
R454	METALFILM RESISTER	RN1/4PC1001F			
R461, 462	METAL OXIDE RESISTOR	RS2LMF221J			

Mark No.	Description	Parts No.
<b>VOLUME ASSEMBLY</b>		
<b>SEMICONDUCTORS</b>		
IC110	IC	UPC4570C
IC111	MECHANISM DRIVER	TA7291S
IC112	IC OP-AMP IC	RC4558DXP
Q118, 119	TRANSISTOR	2SC2878
Q128	TRANSISTOR	2SC2878
<b>CAPACITORS</b>		
C121	ELECTROLYTIC CAPACIT	CEHAQ2R2M50
C132, 133	ELECTROLYTIC CAPACIT	CEHAQ2R2M50
C134, 135	ELECTR.CAPACITOR	CEHAQ100M50
C138	CERAMIC CAPACITOR	CKDYX104M25
C155, 156	CERAMIC CAPACITOR	CKDYX473M25
<b>RESISTORS</b>		
VR101	VR	ACX1047
	Other resistors	RD1/8PM□□□J

#### TRANS COVER ASSEMBLY

No parts are supplied with the TRANS COVER Assembly.

#### 4.2 FOR A - P510/HE TYPE

Mark No.	Description	Parts No.
<b>◎ DISPLAY ASSEMBLY (AWZ3135)</b>		
<b>SEMICONDUCTORS</b>		
Q103, 104	TRANSISTOR	RN2201
Q124, 126	TRANSISTOR	RN2201
Q127	TRANSISTOR	2SA1048
D101, 102	LED	AEL1058
D104	LED	AEL1058
D107	LED (RED)	AEL1108
D108	LED	AEL1100
D109-111	LED (RED)	AEL1108
D132	LED	AEL1058
D134, 135	LED	AEL1100
<b>SWITCHES</b>		
S101	SWITCH	ASG1034
S103-106	SWITCH	ASG1034
S109	SWITCH	ASG1034
S111-115	SWITCH	ASG1034
<b>RESISTORS</b>		
R186, 187	CARBON FILM RESISTOR	RD1/4PM131J
	Other resistors	RD1/8PM□□□J
<b>OTHERS</b>		
	REMOTE RECEIVER UNIT	AXX1010

#### SP TERMINAL ASSEMBLY

<b>COILS</b>		
L751, 752	COIL	ATH-133
<b>RESISTORS</b>		
R757, 758	CARBON FILM RESISTOR	RD1/4PMFL100J
<b>OTHERS</b>		
	PIN JACK (2P)	AKB1146
	SPEAKER TERMINAL 4-P	AKE1026

#### TRANS CONNECT ASSEMBLY

<b>CAPACITORS</b>		
C152	MYLOR FILM CAPACITOR	CQMA103K50
C153	MYLOR FILM CAPACITOR	CQMA103K250
C154	MYLOR FILM CAPACITOR	CQMA103K50



**Mark No. Description Parts No.**

**◎ FUNCTION ASSEMBLY (AWZ3375)**

**SEMICONDUCTORS**

IC101	LOGIC IC	MC14052BCP
IC102	OP-AMP IC	M5218ALF
IC105	AMP CONTROL μ-COM.	PD5144B
IC401	OP-AMP IC	M5218AL
Q101, 102	TRANSISTOR	2SC2878
Q106	TRANSISTOR	RN1201
Q107	TRANSISTOR	RN2201
D114, 115	DIODE	1SS252
D117	DIODE	1SS252
D118	ZENER DIODE	RD2.4ESB2
D119, 125	DIODE	1SS252
D126, 201	DIODE	1SS252

**COIL**

L101	AXIAL INDUCTOR	LAU220K
------	----------------	---------

**CAPACITORS**

C108, 109	CERAMIC CAPACITOR	CCDSL101J50
C111	ELECTROLYTIC CAPACIT	CEJA470M16
C112	ELECTR.CAPACITOR	CEAS221M10
C113	ELECTROLYTIC CAPACIT	CEJA100M25
C114, 115	CERAMIC CAPACITOR	CKDYX473M25
C116	CERAMIC CAPACITOR	CKDYF103Z50
C118	CERAMIC CAPACITOR	CCDSL101J50
C123, 124	ELECTROLYTIC CAPACIT	CEJA330M25
C155, 156	CERAMIC CAPACITOR	CKDYX473M25
C157	ELECTROLYTIC CAPACIT	CEAS471M6
C158, 200	CERAMIC CAPACITOR	CKDYX473M25
C401, 402	CERAMIC CAPACITOR	ACG1017
C403, 404	ELECTR.CAPACITOR	CEAS100M50
C405, 406	CERAMIC CAPACITOR	CKDYB562K50
C407, 408	CERAMIC CAPACITOR	CKDYB152K50
C409, 410	ELECTR.CAPACITOR	CEAS470M10

**RESISTORS**

R148	RESISTOR ARRAY (10k)	RA4T104J
R152, 160	RESISTOR ARRAY (100k)	RA5T104J
	Other resistors	RD1/8PM□□□J

**Mark No. Description Parts No.**

**OTHERS**

	PIN JACK (2P)	AKB1100
	PIN JACK (4P)	AKB1101
CN102	CONNECTOR (15P)	KPE15
CN103	CONNECTOR (9P)	KPE9
X101	CERAMIC RESONATOR	ASS1025

**H.P. ASSEMBLY**

**RESISTORS**

R755, 756	METAL OXIDE RESISTOR	RS2LMF331J
-----------	-------------------------	------------

**OTHERS**

CN	JACK (HEAD PHONE)	AKN1025
----	-------------------	---------

**◎ AF ASSEMBLY (AWZ3383)**

**SEMICONDUCTORS**

IC108	AUDIO IC	STK4172-2GP
IC451	OP-AMP IC	NJM4558S-X
IC701	IC PROTECTOR	ICP-N25
IC801, 802	IC PROTECTOR	ICP-N38
IC803	REGURATOR IC	M5290P
Q108	TRANSISTOR	RN2203
Q120	TRANSISTOR	2SD438
Q451	TRANSISTOR	2SC2458
Q452	TRANSISTOR	2SD438
Q801	TRANSISTOR	2SB1274
Q802	TRANSISTOR	2SD1913
Q807-810	TRANSISTOR	2SC2458
Q811	TRANSISTOR	2SA1048
Q812	TRANSISTOR	2SC2458
Q813	TRANSISTOR	RN2203
Q814	TRANSISTOR	2SC2458
D120, 121	DIODE	1SS252
D123	ZENER DIODE	RD20ESB
D451, 452	DIODE	1SS252
D453-456	ZENER DIODE	RD3.0ESB2
D801	DIODE	RBV602
D802	DIODE	RB152
D806, 807	DIODE	10E2FD
D811	ZENER DIODE	RD7.5ESB
D816, 817	ZENER DIODE	RD12ESB3
D818	DIODE	1SS252
D819	ZENER DIODE	RD6.2ESB
D820	DIODE	1SS252

Mark No.	Description	Parts No.	Mark No.	Description	Parts No.
<b>RELAY</b>			R707, 708	CARBON FILM RESISTOR	RD1/4PM511J
RY803	RELAY	ASR-111	R709, 710	CARBON FILM RESISTOR	RD1/4PMFL4R7J
<b>CAPACITORS</b>			R712, 713	CARBON FILM RESISTOR	RD1/4PM332J
C139	ELECTR.CAPACITOR	CEAS470M50	R714	CARBON FILM RESISTOR	RD1/4PMFL101J
C151	CERAMIC CAPACITOR	CKPUYY103M16	R715	CARBON FILM RESISTOR	RD1/4PM112J
C701, 702	ELECTR.CAPACITOR	CEHAQ100M50	R716	CARBON FILM RESISTOR	RD1/4PMFL101J
C703, 704	CERAMIC CAPACITOR	CKDYB272K50	R717, 718	CARBON FILM RESISTOR	RD1/4PM332J
C705, 706	ELECTROLYTIC CAPACIT	CEHAQ470M50	R719	CARBON FILM RESISTOR	RD1/4PMFL102J
C707-710	MYLOR FILM CAPACITOR	CQMA104K50	R801, 802	METAL OXIDE RESISTOR	RS2LMFR22J
C711, 712	ELECTROLYTIC CAPACIT	CEHAQ100M50	R806	CARBON FILM RESISTOR	RD1/2PMFL123J
C714	ELECTROLYTIC CAPACIT	ACH1186	R807, 808	FUSIBLE RESISTOR	RFA1/4PS470J
C715	ELECTR.CAPACITOR	CEANP100M50	R814	METAL OXIDE RESISTOR	RS2LMF331J
C716	ELECTROLYTIC CAPACIT	CEANP470M50		Other resistors	RD1/8PM□□□J
C717	ELECTROLYTIC CAPACIT	CEANP101M25	<b>OTHERS</b>		
C801, 802	ELECTROLYTIC CAPACIT	ACH1109	CN105	CONNECTOR (14P)	KPE14
C803	ELECTR.CAPACITOR	CEAS222M16	CN107	CONNECTOR (7P)	KPC7
C804	ELECTR.CAPACITOR	CEAS102M16	CN109	CONNECTOR (9P)	KPE9
C805, 806	ELECTROLYTIC CAPACIT	CEHAQ101M10	CN501	SOCKET (14P)	AKP1074
C807	ELECTROLYTIC CAPACIT	CEHAQ222M25	CN502	SOCKET (15P)	AKP1075
C810, 811	ELECTROLYTIC CAPACIT	CEHAQ470M50	CN503	SOCKET (9P)	AKP1072
C812, 813	ELECTR.CAPACITOR	CEHAQ100M50	TH451	THERMISTOR	NTH2218F
C814	ELECTROLYTIC CAPACIT	CEHAQ221M10	<b>TRANS PRIMARY ASSEMBLY</b>		
C815	ELECTR.CAPACITOR	CEAS2R2M50	<b>SEMICONDUCTORS</b>		
C816	ELECTR.CAPACITOR	CEHAQ101M50	Q109	TRANSISTOR	RN1201
C819	ELECTR.CAPACITOR	CEHAQ100M50	D122	DIODE	1SS252
<b>RESISTORS</b>			<b>RELAY</b>		
R258	CARBON FILM RESISTOR	RD1/4PM182J	RY105	RELAY	ASR1027
R259	METAL OXIDE RESISTOR	RS2LMF220J	<b>OTHERS</b>		
R451	METALFILM RESISTER	RN1/4PC2702F	△	AC SOCKET 1-P	AKP1034
R452	METALFILM RESISTER	RN1/4PC8201F	<b>TRANS PRIMARY ASSEMBLY</b>		
R453	METALFILM RESISTER	RN1/4PC1202F	<b>SEMICONDUCTORS</b>		
R454	METALFILM RESISTER	RN1/4PC1001F	Q109	TRANSISTOR	RN1201
R461, 462	METAL OXIDE RESISTOR	RS2LMF221J	D122	DIODE	1SS252
R705, 706	CARBON FILM RESISTOR	RD1/4PM563J	<b>RELAY</b>		

<b>Mark No.</b>	<b>Description</b>	<b>Parts No.</b>
<b>VOLUME ASSEMBLY</b>		
<b>SEMICONDUCTORS</b>		
IC110	IC	UPC4570C
IC111	MECHANISM DRIVER	TA7291S
IC112	IC OP-AMP IC	RC4558DXP
Q118, 119	TRANSISTOR	2SC2878
<b>CAPACITORS</b>		
C121	ELECTROLYTIC CAPACIT	CEHAQ2R2M50
C132, 133	ELECTROLYTIC CAPACIT	CEHAQ2R2M50
C134, 135	ELECTR.CAPACITOR	CEHAQ100M50
C138	CERAMIC CAPACITOR	CKDYX104M25
C159, 160	CERAMIC CAPACITOR	CKDYX473M25
<b>RESISTORS</b>		
VR101	VR	ACX1047
	CARBONFILM RESISTOR	RD1/8PM□□□J

**TRANS COVER ASSEMBLY**

No parts are supplied with the TRANS COVER Assembly.

## 5. DISASSEMBLY

1. Remove the bonnet case (FE) (four screws ①).
2. Remove the front panel assembly (two screws ②).

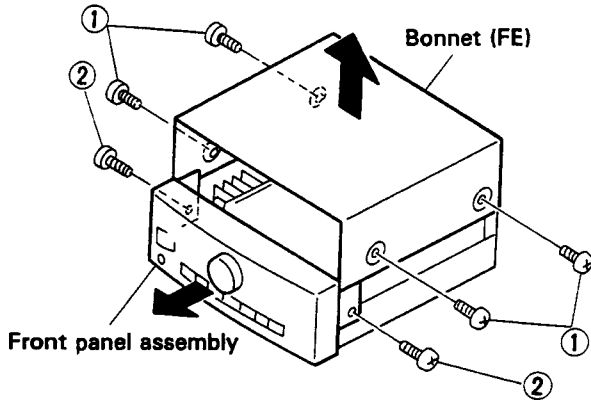

3. Remove the mounting screws of the power transformer (four screws ③).
4. Remove the mounting of screws of the rear panel (three screws ④).
5. Remove the mounting of screws of the fan motor (two screws ⑤).

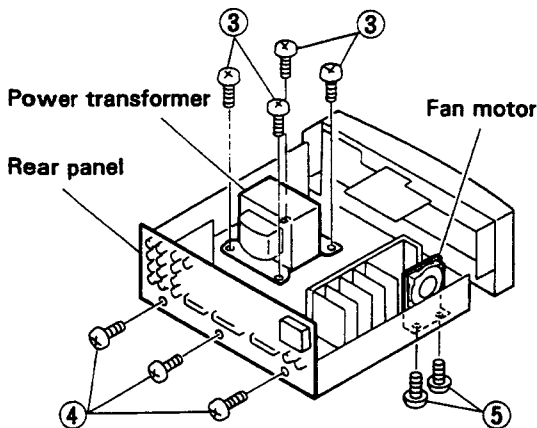

6. Remove the mounting screws of the AF assembly (four screws ⑥).
7. Remove the mounting of screws of the heat sink (two screws ⑦).

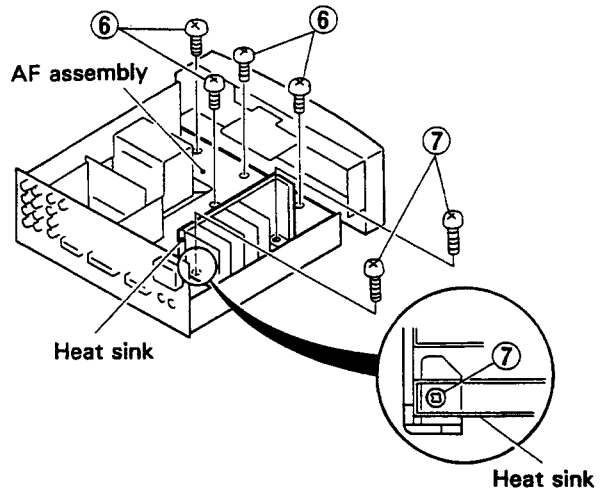

8. Remove the transformer and rear panel from the chassis by lifting them up.

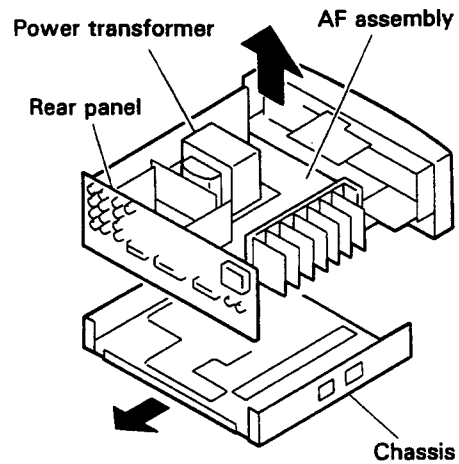

9. Pull the transformer from the AF assembly, and turn and set the main unit so that the heat sink is on the top side.

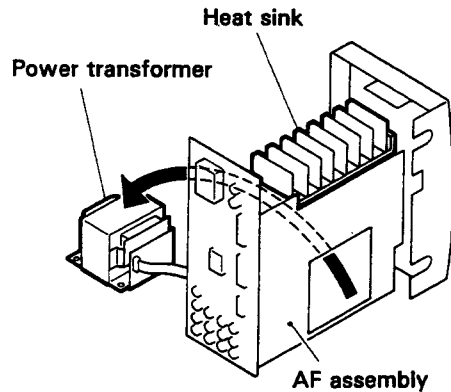

## 6. IC INFORMATION

• PD5144B (MICRO COMPUTER)

• Pin Function

No.	Pin name	I/O	Establishment	Function
1	+5V	—	—	Connected to +5V Power supply
2	GND	—	—	GND
3	VOLref	—	—	Connected to +5V Power supply
4	FAN ON	O	O	Not used
5	LINE.M	O	N	LINE MUTE
6	A4052A	O	N	AUDIO FUNCTION 4052 A
7	A4052B	O	N	AUDIO FUNCTION 4052 B
8	V4052A	O	N	Not used
9	V4052B	O	N	Not used
10	V.A.M	I/O	N	AUDIO MUTE for VCR/DAT REC OUT
11	P.BASS	I/O	N	P-BASS ON/OFF (A-P510 only)
12	VOL.POSI	I/O	I	Analog input for detection of VR position
13	VOL.DN	I/O	N	Motor VR control (DOWN)
14	VOL.UP	I/O	N	Motor VR control (UP)
15	R.V.ST	I/O	N	Not used
16	R.V.CLK	I/O	N	Not used
17	R.V.DATA	I/O	N	Not used
18	E/R TX	I/O	N/I	SYSTEM BUS EN/REQ (TUNER)
19	E/R GR	I/O	N/I	SYSTEM BUS EN/REQ (GEQ and D.S.P.)
20	E/R CT	I/O	N/I	SYSTEM BUS EN/REQ (TAPE)
21	E/R CD	I/O	N/I	SYSTEM BUS EN/REQ (CD)
22	S.DATA	I/O	N/I	SYSTEM BUS DATA
23	S.CLK	I/O	N	SYSTEM BUS CLOCK
24	PHONE	I/O	I	PHONE presence/absence
25	MIC.M	I/O	N	MIC MUTE
26	RMT IN	I	—	REMOTE CONTROL input
27	GND	—	—	GND
28	RESET	I	—	RESET input
29	X IN	I	—	Connected to ceramic oscillator (4MHz)
30	X OUT	O	—	
31	N.C.	O	—	Not used
32	GND	—	—	GND

No.	Pin name	I/O	Establishment	Function
33	4/3.2	I	I	Switching Destination
34	3.4/2	I	I	Switching Destination
35	J/EX	I	I	Switching Destination
36	KI 5	I	I	KEY SCAN Input
37	KI 4	I	I	KEY SCAN Input
38	KI 3	I	I	KEY SCAN Input
39	KI 2	I	I	KEY SCAN Input
40	KI 1	I	I	KEY SCAN Input
41	LED PHONO	I/O	N	LED PHONO
42	LED LD	I/O	N	LED LD (A-P710 only)
43	LED VCR/DAT	I/O	N	LED VCR/DAT
44	LED CT	I/O	N	LED TAPE
45	LED TX	I/O	N	LED TUNER
46	LED CD	I/O	N	LED CD
47	LED PILLOW	I/O	N	LED PILLOW (A-P710 only)
48	LED P.BASS	I/O	N	LED P-BASS
49	KO3	I/O	N	KEY SCAN Output
50	KO2	I/O	N	KEY SCAN Output
51	KO1	I/O	N	KEY SCAN Output
52	LED AUDI	I/O	N	LED VOCAL CANCEL
53	LED AI B	I/O	N	LED B
54	LED AI A	I/O	N	LED A
55	POW IN	I/O	I	POWER IN
56	FAN ERR	I/O	I	FAN ERR
57	LED SURR	I/O	O	LED SURROUND
58	FAN IN	I/O	I	FAN IN
59	RELAY D	I/O	O	Not used
60	RELAY C	I/O	O	Not used
61	RELAY B	I/O	O	RELAY B (A-P710 only)
62	RELAY A	I/O	O	RELAY A
63	BACK UP	I/O	I	BACK UP
64	POWER	I/O	O	POWER

I : CMOS Input  
 O : CMOS Output  
 N : N ch open drain output

## 7. FOR A – P710/HB AND A – P510/HB TYPES

### CONTRAST OF MISCELLANEOUS PARTS

**NOTES:**

- Parts without part number cannot be supplied.
- The  $\Delta$  mark found on some component parts indicates the importance of the safety factor of the part. Therefore, when replacing, be sure to use parts of identical designation.
- Parts marked by “ $\odot$ ” are not always kept in stock. Their delivery time may be longer than usual or they may be unavailable.

The A – P710/HB type is the same as the A – P710/HE type with the exception of the following sections.

Mark	Symbol & Description	Part No.		Remarks
		A – P710/HE type	A – P710/HB type	
	TRANS PRIMARY assembly	Non supply	Non supply	*1
$\Delta$	FU1 Fuse (T1.25A/250V)	AEK – 510	AEK – 509	
$\Delta$	FU5, FU6 Fuse (T2.5A/250V)	AEK – 403	AEK – 512	
$\Delta$	FU3, FU4 Fuse (T2A/250V)	AEK – 017	AEK – 511	
$\Delta$	AC Power cord	ADG1019	ADG1084	
	Screw	ABA1018	.....	

The A – P510/HB type is the same as the A – P510/HE type with the exception of the following sections.

Mark	Symbol & Description	Part No.		Remarks
		A – P510/HE type	A – P510/HB type	
	TRANS PRIMARY assembly	Non supply	Non supply	*1
$\Delta$	FU5, FU6 Fuse (T2.5A/250V)	AEK – 403	AEK – 512	
$\Delta$	FU3, FU4 Fuse (T2A/250V)	AEK – 017	AEK – 511	
$\Delta$	AC Power cord	ADG1019	ADG1084	

\* 1 : A – P710/HE and A – P510/HE of the TRANS PRIMARY assembly are identical assemblies.  
 A – P710/HB and A – P510/HB of the TRANS PRIMARY assembly are also identical assemblies.

### TRANS PRIMARY assembly

The TRANS PRIMARY assembly (A – P710/HB and A – P510/HB) is the same as the TRANS PRIMARY assembly (A – P710/HE and A – P510/HE) with the exception of the following sections.

Mark	Symbol & Description	Part No.		Remarks
		HE type	HB type	
$\Delta$	AC socket (OUTLET 1P)	AKP1034	AKP1035	

## 8. PANEL FACILITIES

### REAR PANEL FACILITIES

STEREO AMPLIFIER: A-P710/A-P510

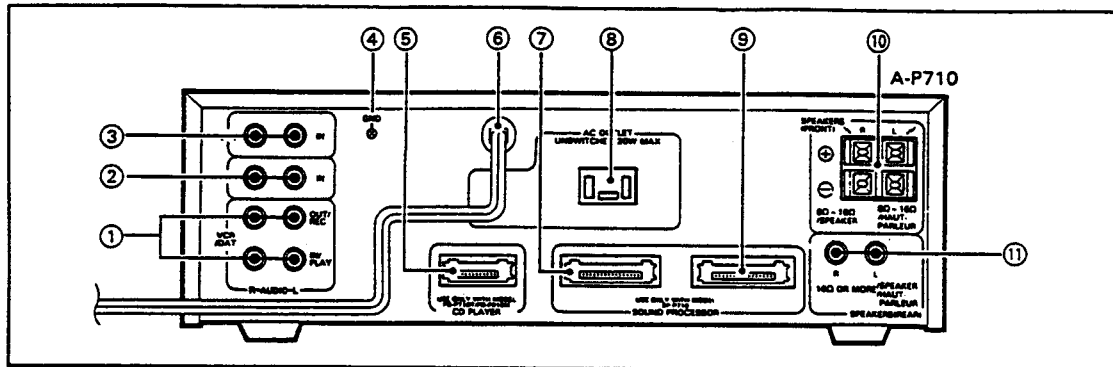

- ① **VCR/DAT jacks**  
**IN/PLAY:**  
 Connect to the audio output jacks of VCR (DAT).  
**OUT/REC:**  
 Connect to audio input jacks of VCR (DAT).
- ② **LD input jacks (A-P710 only)**  
 Connect to audio output Jacks of LD player.
- ③ **PHONO input jacks**  
 Connect the output cable of the turntable to these jacks.
- ④ **Ground terminal (GND)**  
 Use a screwdriver to connect with the ground terminal.
- ⑤ **CD PLAYER jack (blue)**  
 Connect the CD system cable (blue) here.
- ⑥ **Power cord**  
 Connect this to the AC wall socket.
- ⑦ **SOUND PROCESSOR jack (white) .... A-P710**  
**SOUND IMAGE CONTROLLER jack (white) ..... A-P510**  
 Connect the SOUND FIELD PROCESSOR (or SOUND IMAGE CONTROLLER) system cable (white) here.
- ⑧ **AC OUTLET (UNSWITCHED 20W MAX)**  
 Power supplied through this outlet is turned on and off by the amplifier's POWER switch. Total electrical power consumption of connected equipment should not exceed 20W. This power outlet is provided for exclusive use with the tuner F-P710(L) only. This power outlet must not be used to provide electricity to any other component or appliance.  
**NOTE:**  
 In order to avoid overheating or fire risk, do not connect appliances with high power consumption such as heaters, irons, or television sets to the AC OUTLET. This can cause the amplifier to malfunction.
- ⑨ **SOUND PROCESSOR jack (green) .... A-P710**  
**SOUND IMAGE CONTROLLER jack (green) ..... A-P510**  
 Connect the SOUND FIELD PROCESSOR (or SOUND IMAGE CONTROLLER) system cable (green) here.
- ⑩ **SPEAKERS (FRONT) terminals**  
 L: Connect the left speaker system as seen from the listening position.  
 R: Connect the right speaker system as seen from the listening position.  
**NOTE:**  
 Connect a speaker system with a nominal impedance ranging from 8Ω to 16Ω.
- ⑪ **SPEAKERS (REAR) jack**  
 Connect the surround speaker systems.  
**NOTE:**  
 Connect a speaker system with a nominal impedance of 16Ω or more.



## FRONT PANEL FACILITIES

### STEREO AMPLIFIER: A-P710

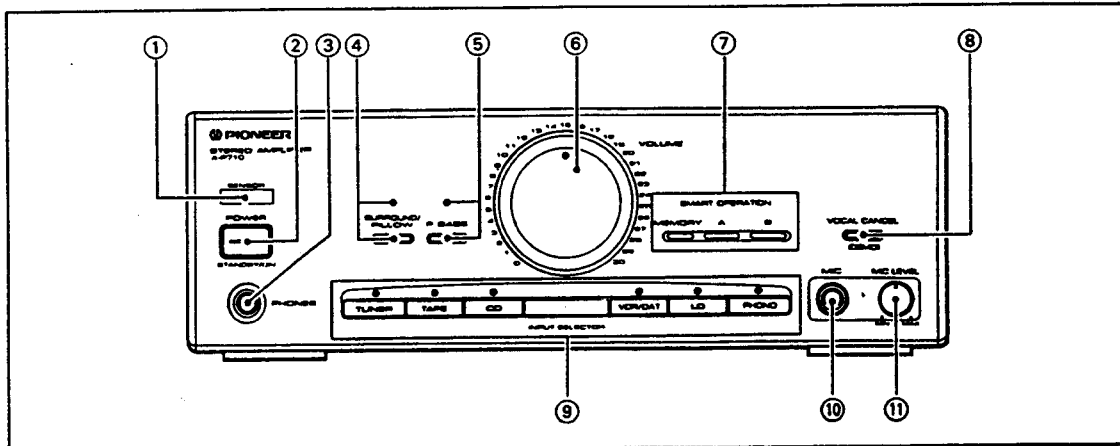

### STEREO AMPLIFIER: A-P510

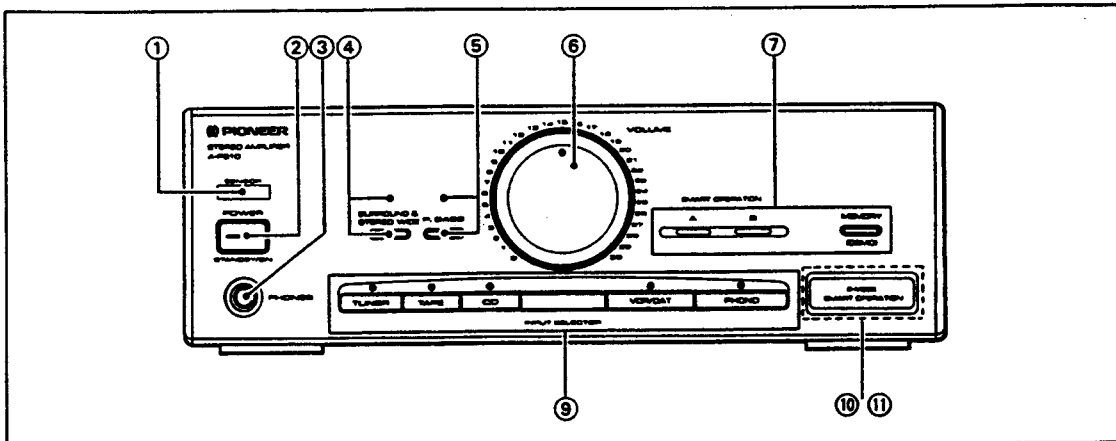

① REMOTE SENSOR window

② POWER STANDBY/ON switch

This is the switch for electric power.

**ON:** When set to the ON position, power is supplied and the unit becomes operational.

**STANDBY:** When set to the STANDBY position, the main power flow is cut and the unit is no longer fully operational. A minute flow of power feeds the unit to maintain operation readiness.

The tuner section display indicates only the time.

- ③ **PHONES (Headphone) jack**  
For stereo headphones.
- NOTE:**  
*There is no speaker output when headphones are plugged into the PHONES jack.*
- ④ **SURROUND/PILLOW button and indicator (A-P710 only)**  
This button allows one-touch switching between the surround speakers and front speakers. The indicator lights orange when SURROUND is selected, and red when PILLOW is selected. When PILLOW is selected, no sound is output from the front speakers.
- ④ **SURROUND & STEREO WIDE button and indicator (A-P510 only)**  
Use this button to select "surround & stereo wide" or normal listening conditions. When surround speakers are connected, the unit switches automatically to "surround" effect, and it switches to "stereo wide" effect if surround speakers are not connected.
- ⑤ **P. BASS button and indicator**  
Set to ON to augment bass frequency response.
- ⑥ **VOLUME control**
- ⑦ **SMART OPERATION buttons**  
**A, B:** To operate the SMART OPERATION function and set the data.  
**MEMORY:** To set the data for SMART OPERATION.
- ⑧ **VOCAL CANCEL button (A-P710 only)**  
When set to ON, the sound volume of vocal sounds is lowered. The sound field processor's SOUND JOG control can also be used to set the vocal volume to the lowest level.
- ⑨ **INPUT SELECTOR buttons**  
**TUNER:** Press to listen to radio broadcasts.  
**TAPE:** Press to listen to cassette tapes.  
**CD:** Press to listen to a CD player.  
**PHONO:** Press to play records on a turntable connected to the PHONO jacks.  
**LD:** Press to play a LaserDisc player connected to the LD jacks (A-P710 only).  
**VCR/DAT:** Press to play a tape on a video cassette recorder (or DAT) connected to the VCR/DAT jacks.
- ⑩ **MIC (Microphone) jack (A-P710 and A-P510 (multi-voltage model) only)**
- ⑪ **MIC LEVEL control (A-P710 and A-P510 (multi-voltage model) only)**

## 9. SPECIFICATIONS

### STEREO AMPLIFIER: A-P710

#### Amplifier Section

Continuously Average Power Output is 32 Watts\* per channel, min., at 8 ohms from 40 Hertz to 20,000 Hertz, with no more than 0.9% total harmonic distortion

\* Measured pursuant to the Federal Trade Commission's Trade Regulation rules on Power Output Claims for Amplifiers

Continuous power output (DIN)  
 U.K., European models ..... 40 W + 40 W  
 (1 kHz, T.H.D 1%, 8 ohms)

Continuous power output (RMS)  
 U.K., European models ..... 46 W + 46 W  
 (1 kHz, T.H.D 5%, 8 ohms)  
 Multi-voltage models ..... 40 W + 40 W  
 (1 kHz, T.H.D 5%, 8 ohms)

Music power (DIN)  
 U.K., European models ..... 68 W + 68 W  
 (1 kHz, T.H.D 10%, 8 ohms)  
 Multi-voltage models ..... 58 W + 58 W  
 (1 kHz, T.H.D 10%, 8 ohms)

Peak music power  
 (Multi-voltage models only) ..... 305 W  
 Total harmonic distortion,  
 1 kHz, 20 W, 8 ohms ..... 0.2%\*

#### Electrical Section, Other

Power requirements  
 European models ..... AC 220 V, 50/60 Hz  
 U.K., models ..... AC 240 V, 50/60 Hz  
 Multi-voltage models ..... AC 110/120-127/  
 220/240 V (switchable), 50/60 Hz

Power consumption  
 European model ..... 180 W  
 Multi-voltage model ..... 190 W

AC outlet ..... Switched: 20 W or less  
 (for exclusive use with F-P710 (L)).

External dimensions .....  
 260 (W) x 83.5 (H) x 260 (D) mm  
 10-3/16 (W) x 3-1/4 (H) x 10-3/16 (D) in

Weight ..... 4.0 kg (8 lb 13 oz.)  
 \* Measured with audio spectrum analyzer.

### STEREO AMPLIFIER: A-P510

#### Amplifier Section

Continuously Average Power Output is 32 Watts\* per channel, min., at 8 ohms from 40 Hertz to 20,000 Hertz, with no more than 0.9% total harmonic distortion

\* Measured pursuant to the Federal Trade Commission's Trade Regulation rules on Power Output Claims for Amplifiers

Continuous power output (DIN)  
 U.K., European models ..... 35 W + 35 W  
 (1 kHz, T.H.D 1%, 8 ohms)

Continuous power output (RMS)  
 U.K., European models ..... 39 W + 39 W  
 (1 kHz, T.H.D 5%, 8 ohms)  
 U.S., Canadian models ..... 38 W + 38 W  
 (1kHz, T.H.D 5%, 8 ohms)  
 Multi-voltage models ..... 40 W + 40 W  
 (1 kHz, T.H.D 5%, 8 ohms)

Music power (DIN)  
 U.K., European models ..... 57 W + 57 W  
 (1 kHz, T.H.D 10%, 8 ohms)  
 Multi-voltage models ..... 58 W + 58 W  
 (1,kHz, T.H.D 10%, 8 ohms)

Peak music power  
 (Multi-voltage models only) ..... 305 W  
 Total harmonic distortion,  
 1 kHz, 17.5 W, 8 ohms ..... 0.2%\*

#### Electrical Section, Other

Power requirements  
 European models ..... AC 220 V, 50/60 Hz  
 U.K., models ..... AC 240 V, 50/60 Hz  
 U.S., Canadian models ..... AC 120 V, 60 Hz  
 Multi-voltage models ..... AC 110/120-127/  
 220/240 V (switchable), 50/60 Hz

Power consumption  
 European model ..... 170 W  
 U.S., Canadian models ..... 115 W  
 Multi-voltage model ..... 190 W

AC outlet ..... Switched: 20 W or less  
 (for exclusive use with F-P710 (L)).

External dimensions .....  
 260 (W) x 83.5 (H) x 260 (D) mm  
 10-3/16 (W) x 3-1/4 (H) x 10-3/16 (D) in

Weight ..... 3.9 kg (8 lb 9 oz.)  
 \* Measured with audio spectrum analyzer.

#### NOTE:

The specifications and design of this product are subject to change without notice, due to improvements.