

ADDITIONAL

 **PIONEER®**
The future of sound and vision.

Service Manual

Original

**ORDER NO.
ARP1462**

STEREO AMPLIFIER

A-X530 HEZ

• For servicing this type, please refer to the A-X530/HE service manual (ARP1445) with the exception of this additional service manual.

• This additional service manual is applicable to the HEZ type.

PIONEER ELECTRONIC CORPORATION 4-1, Meguro 1-Chome, Meguro-ku, Tokyo 153, Japan
PIONEER ELECTRONICS SERVICE INC. P.O. Box 1760, Long Beach, California 90801 U.S.A.
PIONEER ELECTRONICS OF CANADA, INC. 505 Cochrane Drive, Markham, Ontario L3R 8E3 Canada
PIONEER ELECTRONIC [EUROPE] N.V. Keetberglaan 1, 2740 Beveren, Belgium
PIONEER ELECTRONICS AUSTRALIA PTY. LTD. 178-184 Boundary Road, Braeside, Victoria 3195, Australia TEL: [03] 580-9911

YA © JULY 1987 Printed in Japan

1. CONTRAST OF MISCELLANEOUS PARTS

NOTES:

- Parts without part number cannot be supplied.
- Parts marked by "⊙" are not always kept in stock. Their delivery time may be longer than usual or they may be unavailable.
- The Δ mark found on some component parts indicates the importance of the safety factor of the part. Therefore, when replacing, be sure to use parts of identical designation.
- For your parts Stock Control, the fast moving items are indicated with the marks **★★** and **★**.
- ★★ **GENERALLY MOVES FASTER THAN ★**
This classification shall be adjusted by each distributor because it depends on model number, temperature, humidity, etc.
- When ordering resistors, first convert resistance values into code form as shown in the following examples.

Ex. 1 When there are 2 effective digits (any digit apart from 0), such as 560 ohm and 47k ohm (tolerance is shown by J = 5%, and K = 10%).

560Ω	56 × 10 ¹	561.....	RD1/4PS	Ⓢ	Ⓠ	Ⓜ	J
47kΩ	47 × 10 ³	473.....	RD1/4PS	Ⓢ	Ⓠ	Ⓜ	J
0.5Ω	0R5.....		RN2H	Ⓢ	Ⓠ	Ⓜ	K
1Ω	010.....		RS1P	Ⓢ	Ⓠ	Ⓜ	K

Ex. 2 When there are 3 effective digits (such as in high precision metal film resistors).

5.62kΩ	562 × 10 ¹	5621.....	RN1/4SR	Ⓢ	Ⓠ	Ⓜ	F
--------	-----------------------	-----------	---------	---	---	---	---

The A-X530/HEZ type is the same as the A-X530/HE type with the exception of the following sections.

Mark	Symbol & Description	Part No.		Remarks
		A-X530 HE type	A-X530 HEZ type	
	AF Main assembly	AWZ1409	AWZ1530	
	Power supply assembly	Non supply	
	SP OUT assembly	Non supply	Non supply	
	Operating Instructions (English/German/French/Italian)	ARE1051	
	Operating instructions (German)	ARC1064	
	Screw	ABA-115	

2. ELECTRICAL PARTS LIST

AF MAIN assembly (AWZ1530)

SEMICONDUCTORS

Mark	Symbol & Description	Part No.
★★	IC101	M5218P
★★	IC103	M5218PF
★★	IC601	M5278L56(A)
★★	IC301,IC302	PA0016
★★	IC602	TA7291S
★★	IC102	TC9163N
★★	Q408	RN2203 (DTA124ES) (2SA1346)
★★	Q407	RN1203 (2SC3400)
★★	Q405	2SA1048 (JA101) (2SA1115) (2SA933S)

Mark	Symbol & Description	Part No.
★★	Q313,Q314	2SA1145
★★	Q319,Q320	2SA968
★★	Q307-Q310	2SA992
★★	Q604	2SB560
★★	Q301-Q306,Q401,Q402	2SC1845
★★	Q317,Q318	2SC2238
★★	Q403,Q404	2SC2458 (JC501) (2SC1740S) (2SC2603)
★★	Q315,Q316	2SC2705
★★	Q406,Q602,Q603	2SD438
★★	Q601	2SD880
★	D601	D5SB20F
★	D406	RD13ESB

3. SCHEMATIC DIAGRAM

Mark	Symbol & Description	Part No.
★	D608	RD13ESB1
★	D608, D609	RD16ESB3
★	D319, D320, D323, D324	RD4.7EB (HZ4.7EB)
★	D405	RD5.6ESB
★	D301 - D306, D309 - D314, D317, D318, D321, D322, D401 - D404, D614, D616	1SS131
★	D602 - D605, D610 - D613	11E2 (S5568)
RELAYS		
Mark	Symbol & Description	Part No.
★★	RY401 Relay (PROTECTION)	ASR-112
★★★	RY601 Relay (POWER)	ASR-512
COILS AND TRANSFORMER		
Mark	Symbol & Description	Part No.
	L301, L302 AF Choke coil (0.7 μF)	ATH1011
⚠	T601 Power transformer (AC110, 120 - 127/220V, 240V)	ATT1015
CAPACITORS		
Mark	Symbol & Description	Part No.
⚠	C614 (0.01 μF/400V)	ACG1002
	C609, C610, C613 (0.01 μF/150V)	ACG1005
	C601, C602 (8200 μF/63V)	ACH1044
	C325 - C328	CCCSL101K500
	C311 - C314	CCCSL150J50
	C303, C304	CCCSL221J50
	C703, C704, C713, C714	CCCSL271J50
	C305 - C308, C321, C322	CCCSL470J50
	C319, C320, C323, C324	CCCSL680J50
	C401, C402	CEANP010M50
	C405	CEAS010M100
	C406	CEAS010M50
	C101, C102, C119, C120	CEAS100M25
	C612	CEAS101M10
	C404	CEAS101M25
	C811	CEAS102M25
	C603, C604	CEAS102M35
	C115, C116	CEAS2R2M50
	C105, C106	CEAS470M10
	C113, C114, C123, C124	CEAS470M16
	C606	CEAS470M25
	C403	CEAS471M6
	C301, C302	CEYA100M25
	C607, C608	CEYA101M25
	C315, C316	CEYA331M16
	C615, C616	CEYA470M25
	C335, C336	CEYA470M63
	C317, C318, C333, C334	CFTXA223J50
	C329 - C332	CFTXA823J50
	C309, C310	CKCYB182K50

Mark	Symbol & Description	Part No.
	C103, C104	CKCYB331K50
	C107, C108, C701, C702, C705 - C712, C715, C716	CKCYB391K50
	C117, C118, C121, C122	CKCYX104M25
	C109, C110	CQMA222J50
	C723	CQMA472K50
	C111, C112	CQMA822J50

RESISTORS

Mark	Symbol & Description	Part No.
	R361, R362 Resistor network (0.33Ωx2)	ACN-139
⚠	R313 - R316, R359, R360	RDR1/4PM□□□J
⚠	R365, R366, R371, R372, R610	RD1/4PMFL□□□J
⚠	R343 - R360, R365 - R368, R363, R364	RD1/4PMF□□□J
⚠	R351 - R354, R602, R604, R605 R607, R608, R620 - R622 R103, R104, R131 - R134, R139 - R141, R317, R318, R339 - R342, R369, R370, R403 - R407, R410 - R413, R612 - R614, R618, R619	RFA1/4PS□□□J RS1LMF□□□J RD1/8PM□□□J
	Other resistors	RD1/4PM□□□J

OTHERS

Mark	Symbol & Description	Part No.
⚠	Terminal 6P (ADAPTER IN/OUT, TAPE1, REC/PLAY, TUNER, CD)	AKB-117
	Terminal 2P (PHONO)	AKB-119
	Transistor socket	AKH-017

SP OUT assembly

COILS

Mark	Symbol & Description	Part No.
	L701 - L704 AF Choke coil (1 μF)	ATH-133

CAPACITORS

Mark	Symbol & Description	Part No.
	C717 - C720	CQMA103K50
	C721, C722	CQMA472K50

RESISTORS

Mark	Symbol & Description	Part No.
	R701, R702	RD1/4PM4R7J

OTHERS

Mark	Symbol & Description	Part No.
	Terminal 8P (Speaker)	AKE-111
	Mini-Jack (REMOTE CONTROL OUT)	AKN-207

Power supply assembly

COIL

Mark	Symbol & Description	Part No.
	L3 Line filter	ATF-151

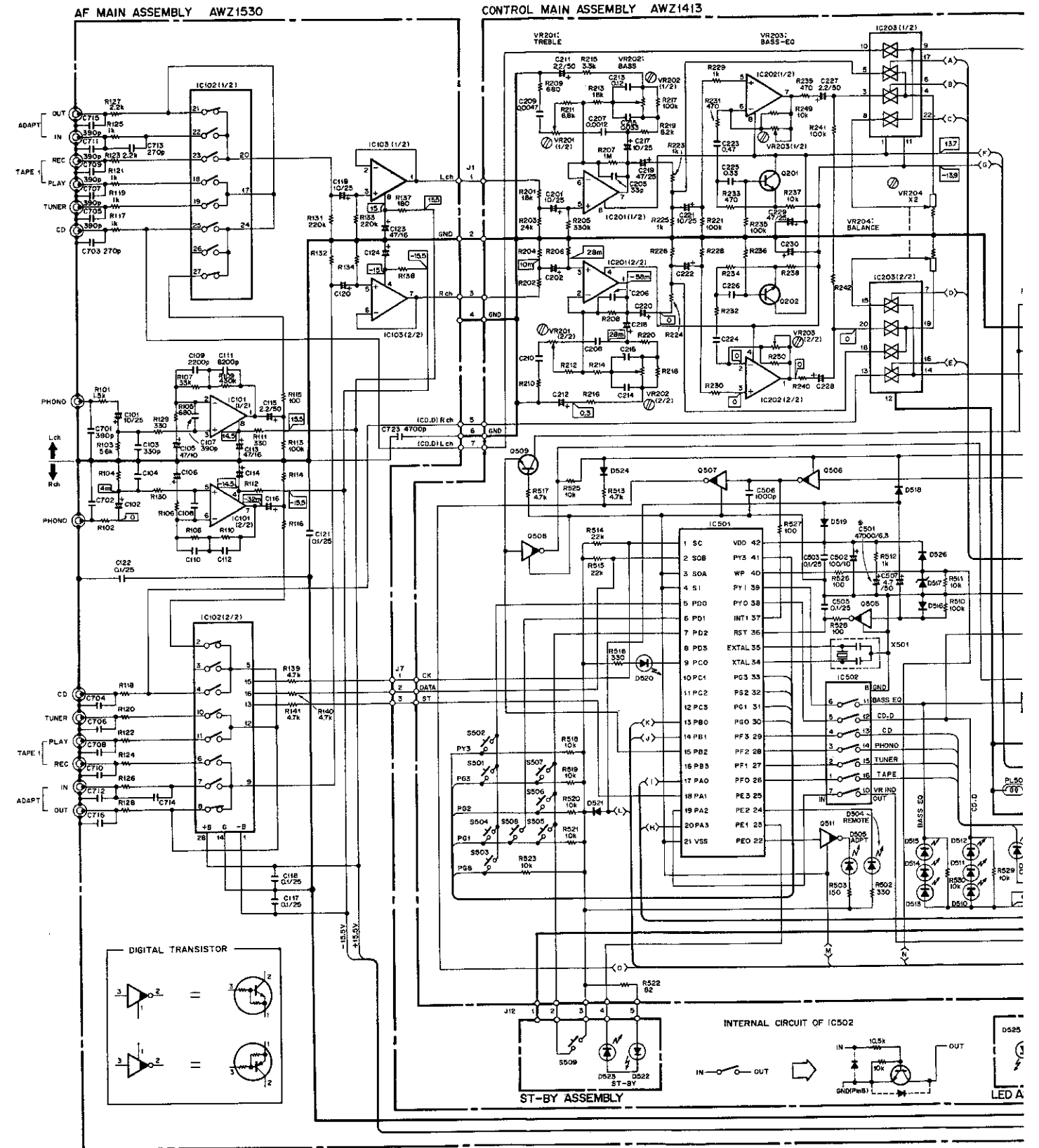

A

B

C

D

1

2

3

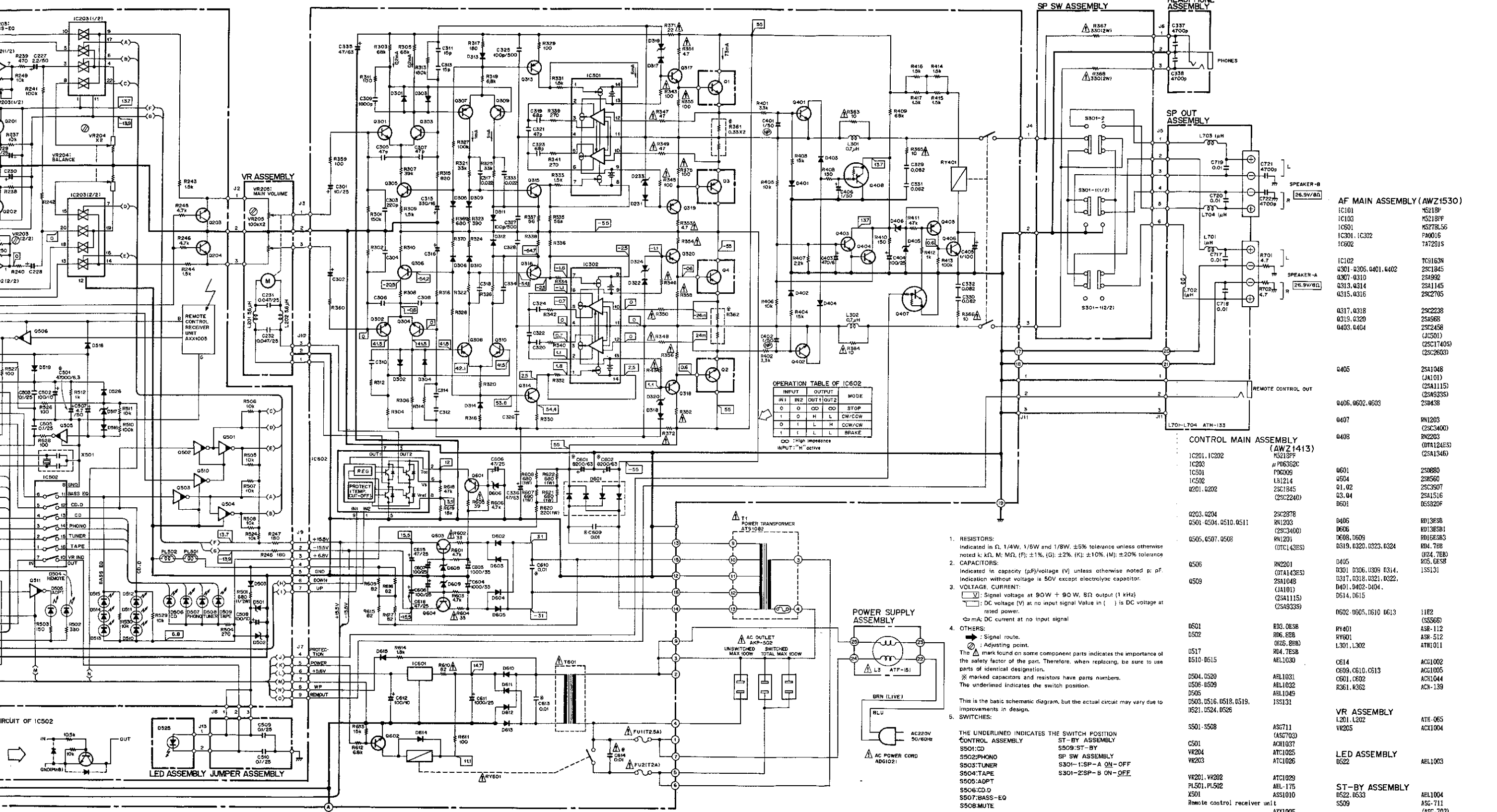

OPERATION TABLE OF IC602

IN1	IN2	OUT1	OUT2	MODE
0	0	0	0	STOP
1	0	H	L	CW/CW
0	1	L	H	CCW/CW
1	1	L	L	BRAKE

∞ : High impedance
INPUT: "H" active

- RESISTORS:** Indicated in Ω, 1/4W, 1/8W and 1/8W. ±5% tolerance unless otherwise noted; k: KΩ, M: MΩ, (F): ±1%, (G): ±2%, (K): ±10%, (M): ±20% tolerance.
 - CAPACITORS:** Indicated in capacity (μF)/voltage (V) unless otherwise noted; p: pF. Indication without voltage is 50V except electrolytic capacitor.
 - VOLTAGE, CURRENT:**
 - : Signal voltage at 90W + 90W, 8Ω output (1 kHz)
 - : DC voltage (V) at no input signal. Value in () is DC voltage at rated power.
 - mA: DC current at no input signal
 - OTHERS:**
 - : Signal route.
 - ⊙: Adjusting point.
 - ⚠: The mark found on some component parts indicates the importance of the safety factor of the part. Therefore, when replacing, be sure to use parts of identical designation.
 - *: marked capacitors and resistors have parts numbers.
 - ⏟: The underlined indicates the switch position.
 - SWITCHES:**
 - THE UNDERLINED INDICATES THE SWITCH POSITION
 - CONTROL MAIN ASSEMBLY: ST-BY ASSEMBLY
 - S501: CD
 - S502: PHONO
 - S503: TUNER
 - S504: TAPE
 - S505: ADPT
 - S506: CD.D
 - S507: BASS-EQ
 - S508: MUTE
 - S509: ST-BY
 - S301-1: SP-A ON-OFF
 - S301-2: SP-B ON-OFF
- This is the basic schematic diagram, but the actual circuit may vary due to improvements in design.

- AF MAIN ASSEMBLY (AWZ1530)**
- IC101: M5218P
 - IC103: M5218PF
 - IC501: M5278L56
 - IC301, IC302: P960156
 - IC602: T872915
 - IC102: TC9163N
 - Q301-Q305, Q401, Q402: 2SC1845
 - Q307-Q310: 2SC4992
 - Q313, Q314: 2SA1145
 - Q315, Q316: 2SC2705
 - Q317, Q318: 2SC2238
 - Q319, Q320: 2SA968
 - Q403, Q404: 2SC2458
 - Q405: (JCS01)
 - Q406: (2SC1740S)
 - Q407: (2SC2633)
 - Q408: 2SA1048
 - Q409: (JA101)
 - Q410: (2SA1115)
 - Q411: (2SA933S)
 - Q412: 2SA438
 - Q413: RN1203
 - Q414: (2SC3400)
 - Q415: RN2203
 - Q416: (DT124ES)
 - Q417: (2SA1346)
 - Q418: 0601
 - Q419: 2SC680
 - Q420: 0604
 - Q421: 2SC560
 - Q422: 01, 02
 - Q423: 2SC1845
 - Q424: (2SC2240)
 - Q425: 05, 04
 - Q426: 2SA1516
 - Q427: 05S20F
 - Q428: 0406
 - Q429: 2SC2878
 - Q430: 0501, 0504, 0510, 0511
 - Q431: RN1203
 - Q432: (2SC3400)
 - Q433: RN1201
 - Q434: (DT143ES)
 - Q435: 0405
 - Q436: RN2201
 - Q437: (DT143ES)
 - Q438: 2SA1048
 - Q439: (JA101)
 - Q440: (2SA1115)
 - Q441: (2SA933S)
 - Q442: 0602, 0605, 0610, 0613
 - Q443: RY401
 - Q444: 0606
 - Q445: RN13ESB1
 - Q446: D608, D609
 - Q447: RFI6ESB3
 - Q448: R4, 7E8
 - Q449: (R4, 7E8)
 - Q450: R5, 6E38
 - Q451: 1SS131
 - Q452: 11E2
 - Q453: (SS565)
 - Q454: ASR-112
 - Q455: RY601
 - Q456: ASR-512
 - Q457: L301, L302
 - Q458: ATN1011
 - Q459: CE14
 - Q460: ACQ1002
 - Q461: C609, C610, C613
 - Q462: ACQ1005
 - Q463: C601, C602
 - Q464: ACN1044
 - Q465: R361, R362
 - Q466: ACN-139
 - Q467: VR201, VR202
 - Q468: ATC1029
 - Q469: PL501, PL502
 - Q470: AEL-175
 - Q471: X501
 - Q472: ASS1010
 - Q473: AEL1004
 - Q474: ASG-711
 - Q475: (ASG-703)
 - Q476: Remote control receiver unit
 - Q477: AXX1005
- CONTROL MAIN ASSEMBLY (AWZ1413)**
- IC201, IC202: M5218PF
 - IC203: M P66352C
 - IC501: P96009
 - IC502: L1214
 - Q201, Q202: 2SC1845
 - Q203, Q204: (2SC2240)
 - Q205, Q206, Q507, Q508: 2SC2878
 - Q509: 0501, 0504, 0510, 0511
 - Q510: RN1203
 - Q511: (2SC3400)
 - Q512: RN1201
 - Q513: (DT143ES)
 - Q514: 0405
 - Q515: RN2201
 - Q516: (DT143ES)
 - Q517: 2SA1048
 - Q518: (JA101)
 - Q519: (2SA1115)
 - Q520: (2SA933S)
 - Q521: 0602, 0605, 0610, 0613
 - Q522: RY401
 - Q523: 0606
 - Q524: RN13ESB1
 - Q525: D608, D609
 - Q526: RFI6ESB3
 - Q527: R4, 7E8
 - Q528: (R4, 7E8)
 - Q529: R5, 6E38
 - Q530: 1SS131
 - Q531: 11E2
 - Q532: (SS565)
 - Q533: ASR-112
 - Q534: RY601
 - Q535: ASR-512
 - Q536: L301, L302
 - Q537: ATN1011
 - Q538: CE14
 - Q539: ACQ1002
 - Q540: C609, C610, C613
 - Q541: ACQ1005
 - Q542: C601, C602
 - Q543: ACN1044
 - Q544: R361, R362
 - Q545: ACN-139
 - Q546: VR201, VR202
 - Q547: ATC1029
 - Q548: PL501, PL502
 - Q549: AEL-175
 - Q550: X501
 - Q551: ASS1010
 - Q552: AEL1004
 - Q553: ASG-711
 - Q554: (ASG-703)
 - Q555: Remote control receiver unit
 - Q556: AXX1005
- LED ASSEMBLY**
- D522: AEL1003
- ST-BY ASSEMBLY**
- D522, D533: AEL1004
 - D509: ASG-711
 - D510: (ASG-703)

A
B
C
D

4. P.C. BOARD PATTERNS

AF MAIN ASSEMBLY AWZ1530

Q1 Q315 IC301 Q317 Q319 Q303 Q401 Q405 Q406 Q407 Q402 IC601 Q602 IC102 Q408 Q404 Q403 Q320 Q4 IC103 Q604 IC101 Q305 Q307 Q309 Q301 Q304 Q302 Q310 Q308 Q306 Q314 Q316 Q2 Q601 Q603 IC602

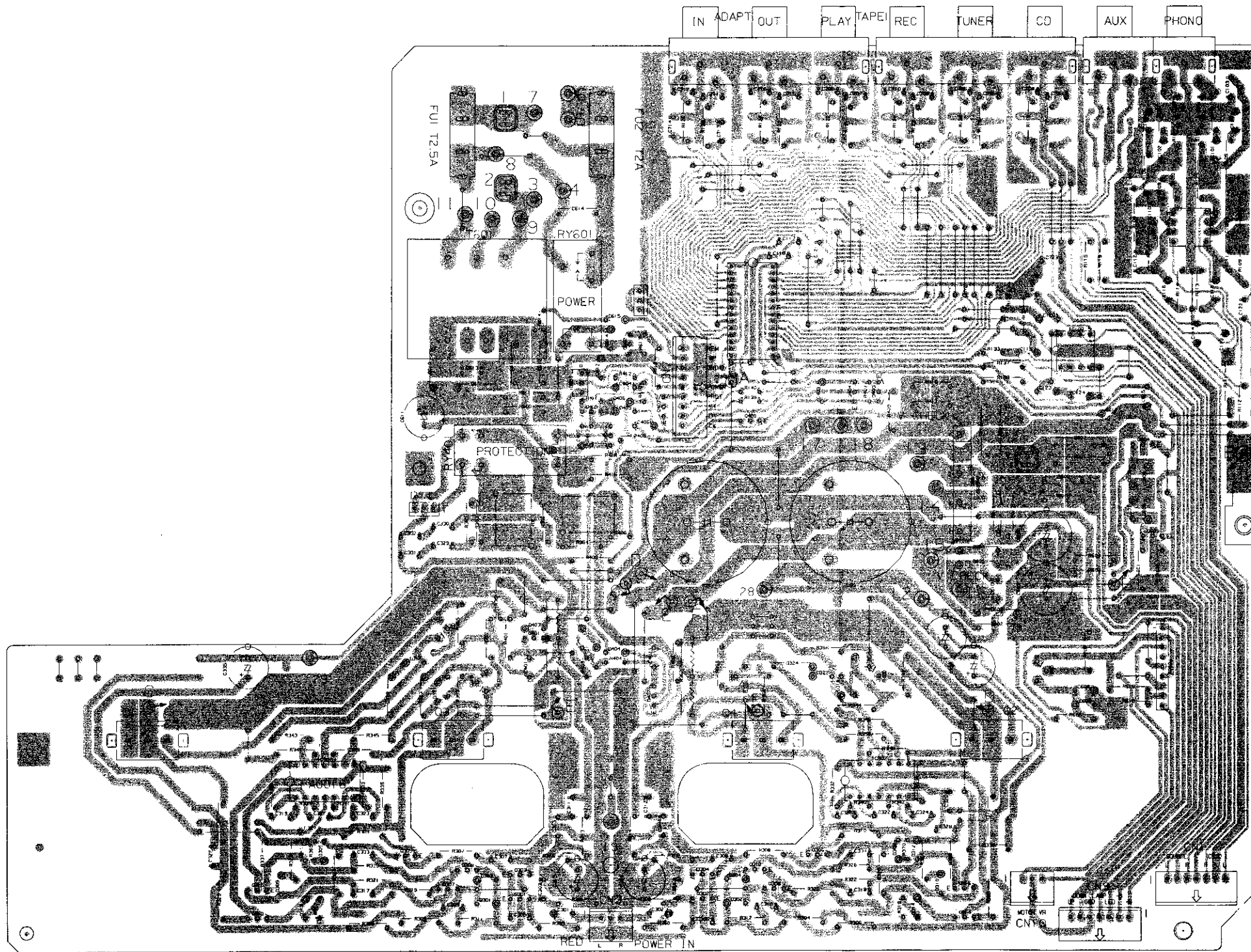

NOTE
 1. This P.C.B. connection diagram is viewed from the parts mounted side.
 2. The parts which have been mounted on the board can be replaced with those shown with the corresponding wiring symbols listed in the following Table.

P.C.B. pattern diagram indication	Corresponding part symbol	Part Name
		Transistor
		Radiator type transistor
		Diode
		Resistor
		Capacitor (Polarity)
		Capacitor (Non-polarity)

Others

P.C.B. pattern diagram indication	Part Name
IC	IC
S	Switch
RY	Relay
L	Coil
F	Filter
VR	Variable resistor or Semi-fixed resistor

- The capacitor terminal marked with ⊕ (double circles) shows negative terminal.
- The diode terminal marked with ⊕ (double circles) shows cathode side.
- The transistor terminal to which E is affixed shows the emitter.

SP OUT ASSEMBLY

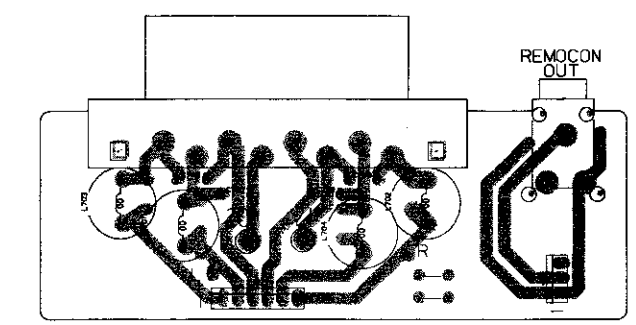

1876



Service Manual

Original

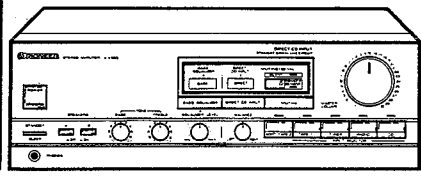

ORDER NO.
ARP1445

STEREO AMPLIFIER

A-X530

MODEL A-X530 COMES IN THREE VERSIONS DISTINGUISHED AS FOLLOWS:

Type	Power requirement	Export destination
HE	AC220V, 240V (switchable)*	European continent
HB	AC220V, 240V (switchable)*	United Kingdom
SD	AC110V, 120-127V, 220V, 240V (switchable)	General market

*Change the primary wiring of the power transformer.

- This service manual is applicable to the HE, HB and SD types.
- As to the HB and SD types, please refer to pages 22-23.

CONTENTS

1.	SAFETY INFORMATION	2
2.	SPECIFICATIONS	2
3.	PANEL FACILITIES	3
4.	EXPLODED VIEW AND PARTS LIST	5
5.	SCHEMATIC DIAGRAM	8
6.	P.C.BOARDS CONNECTION DIAGRAM	11
7.	ELECTRICAL PARTS LIST	19
8.	FOR HB AND SD TYPES	22
9.	PACKING	24

PIONEER ELECTRONIC CORPORATION 4-1, Meguro 1-Chome, Meguro-ku, Tokyo 153, Japan
PIONEER ELECTRONICS SERVICE INC. P.O. Box 1760, Long Beach, California 90801 U.S.A.
PIONEER ELECTRONICS OF CANADA, INC. 505 Cochrane Drive, Markham, Ontario L3R 8E3 Canada
PIONEER ELECTRONIC [EUROPE] N.V. Keetberglaan 1, 2740 Beveren, Belgium
PIONEER ELECTRONICS AUSTRALIA PTY. LTD. 178-184 Boundary Road, Braeside, Victoria 3195, Australia TEL: [03] 580-9911

1876

1. SAFETY INFORMATION

1. SAFETY PRECAUTIONS

The following check should be performed for the continued protection of the customer and service technician.

LEAKAGE CURRENT CHECK

Measure leakage current to a known earth ground (water pipe, conduit, etc.) by connecting a leakage current tester such as Simpson Model 229-2 or equivalent between the earth ground and all exposed metal parts of the appliance (input/output terminals, screwheads, metal overlays, control shaft, etc.). Plug the AC line cord of the appliance directly into a 120V AC 60Hz outlet and turn the AC power switch on. Any current measured must not exceed 0.5mA.

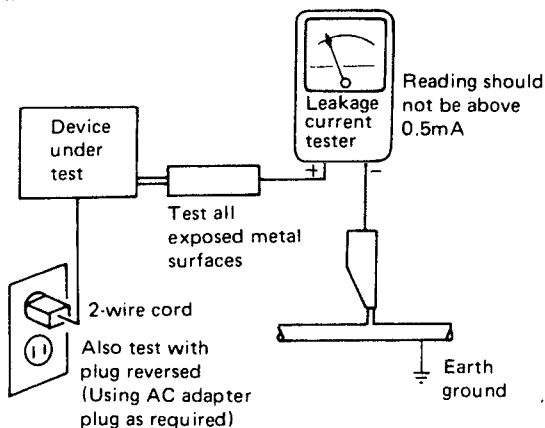

AC Leakage Test

ANY MEASUREMENTS NOT WITHIN THE LIMITS OUTLINED ABOVE ARE INDICATIVE OF A POTENTIAL SHOCK HAZARD AND MUST BE CORRECTED BEFORE RETURNING THE APPLIANCE TO THE CUSTOMER.

2. PRODUCT SAFETY NOTICE

Many electrical and mechanical parts in the appliance have special safety related characteristics. These are often not evident from visual inspection nor the protection afforded by them necessarily can be obtained by using replacement components rated for voltage, wattage, etc. Replacement parts which have these special safety characteristics are identified in this Service Manual.

Electrical components having such features are identified by marking with a Δ on the schematics and on the parts list in this Service Manual.

The use of a substitute replacement component which does not have the same safety characteristics as the PIONEER recommended replacement one, shown in the parts list in this Service Manual, may create shock, fire, or other hazards.

Product safety is continuously under review and new instructions are issued from time to time. For the latest information, always consult the current PIONEER Service Manual. A subscription to, or additional copies of, the PIONEER Service Manual may be obtained at a nominal charge from PIONEER.

2. SPECIFICATIONS

Amplifier Section

DIN continuous power output (both channels driven)	
1 kHz, 1%, 8 Ω	90 W + 90 W
DIN music power (both channels driven)	
1 kHz, 1%, 8 Ω	150 W + 150 W
Total harmonic distortion	
1 kHz, 45 W, 8 Ω	0.003%*
Input (sensitivity/impedance)	
PHONO.....	2.5 mV/50 k Ω
TUNER, CD, TAPE PLAY, ADAPTOR.....	150 mV/50 k Ω
Overload level	
PHONO 1 kHz, 0.1%.....	150 mV
Output level	
TAPE REC, ADAPTOR OUT.....	150 mV
Frequency Response	
PHONO.....	20 Hz to 20 kHz ± 0.5 dB
TUNER, CD, TAPE PLAY, ADAPTOR.....	10 Hz to 70 kHz $\pm 1/2$ dB
DIRECT CD.....	10 Hz to 100 kHz $\pm 1/2$ dB
Tone Control	
BASS.....	± 8 dB 100 Hz
TREBLE.....	± 8 dB 10 kHz
BASS EQUALIZER.....	(MAX) + 10 dB 60 Hz
MUTING.....	$-\infty$
Hum and Noise (IHF short circuited, A network)	
PHONO.....	72 dB
DIRECT CD INPUT.....	102 dB
Hum and Noise (DIN, continuous power/50 mW)	
PHONO.....	68 dB/60 dB
DIRECT CD INPUT.....	82 dB/62 dB

Power Supply/Miscellaneous

Power requirements	
European model.....	AC 220 V~, 50/60 Hz
U.K., Australian models.....	AC 240 V~, 50/60 Hz
Power consumption	
European model.....	450 W
U.K., Australian models.....	450 W
AC outlets	
Switched (x 2).....	100 W
Unswitched (x 1).....	100 W
Dimensions.....	360 (W) x 344 (D) x 115 (H) mm
	14-3/16 (W) x 13-5/8 (D) x 3-2/4 (H) in
Weight.....	7.3 kg (16 lb 1 oz)

Accessories

Remote control unit.....	1
Batteries AAA/R03.....	2
Operating instructions.....	1
Control cord.....	1

• Specifications and design subject to possible modification without notice due to improvements.

• Measured by Audio Spectrum Analyzer.

3. PANEL FACILITIES

FRONT PANEL

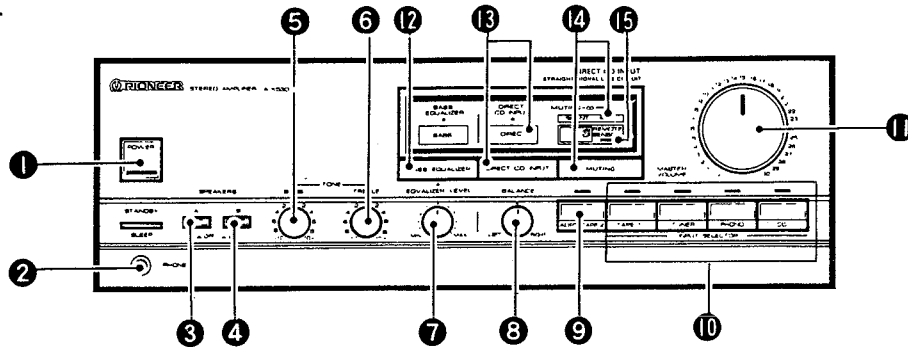

1 POWER switch/STANDBY (SLEEP) indicator

Press to turn power to the unit ON and STANDBY. This indicator flashes when the accessory remote control unit is used to turn the SLEEP key. When the SLEEP key is ON, the indicator will light. (Initially it will flash slowly, then gradually become faster.)

Approx 60 minutes after the sleep timer is turned ON, the power switch will be turned STANDBY automatically.

- The POWER switch selects the transformer's secondary even in STANDBY position. The unit's circuitry will work as long as the power cord is connected to a power outlet.
- When not using the unit for a long period, disconnected the power cord.

2 PHONES jack

When using headphones, insert the plug into this jack.

3 SPEAKERS A selector switch

Use this switch to listen to the speaker systems connected to the SPEAKERS A terminals.

[ON] — Depressed position: Sound is heard from the speaker systems.

[OFF] — Released position: No sound is heard from the speaker systems. Set to this position when listening with headphones.

4 SPEAKERS B selector switch

Use this switch to listen to the speaker systems connected to the SPEAKERS B terminals.

[ON] — Depressed position: Sound is heard from the speaker systems.

[OFF] — Released position: No sound is heard from the speaker systems. Set to this position when listening with headphones.

NOTE:

When the speaker system is connected to only one speaker terminal (A or B) and both A and B selector switches are ON, there will be no sound. Turn ON only the selector to which the speaker system is connected.

5 BASS tone control

Use to adjust the low-frequency tone. The center position is the flat (normal) position. When moved to the right, low-frequency tones are emphasized; when moved to the left, low-frequency tones are de-emphasized.

NOTE:

This function does not operate when the DIRECT CD INPUT switch is in the ON position.

6 TREBLE tone control

Use to adjust the high-frequency tone.

The center position is the flat (normal) position. When moved to the right, high-frequency tones are emphasized; when moved to the left, high-frequency tones are de-emphasized.

NOTE:

This function does not operate when the DIRECT CD INPUT switch is in the ON position.

7 EQUALIZER LEVEL control

When the BASS EQUALIZER switch is ON, you can control the degree of enhancement of very low frequencies below 60 Hz in variable using this control. Set this control to the desired position.

NOTE:

This function does not operate when the DIRECT CD INPUT switch is in the ON position.

8 BALANCE control

Should normally be left in the center position. Adjust balance if the sound is louder from one of the speakers. If the right side is louder, move toward the LEFT position and if the left side is louder, move toward the RIGHT position.

NOTE:

This function does not operate when the DIRECT CD INPUT switch is in the ON position.

9 ADPT/TAPE2 switch/indicator

Use when there is an adaptor component (graphic equalizer, etc.) or tape deck connected to the ADAPTOR/TAPE 2 terminals.

[OFF] — Indicator goes out position: When not in use.

[ON] — Indicator lights position: When using the adaptor component or listening to the tape deck.

NOTE:

When no connections are made to the ADAPTOR/TAPE 2 terminals, or when they are not in use, be sure to set this switch to the OFF position. (No sound will be heard if it is set to the ON position.)

10 INPUT SELECTOR switches/indicators

Use to select playback source.

[TAPE 1]—Press when listening to tape playback with a tape deck.

[TUNER] — Press when listening to AM or FM broadcasts with a tuner.

[PHONO] — Press when listening to record playback on a turntable.

[CD] — Press when listening to a compact disc playback with a CD player.

11 MASTER VOLUME control

Use to adjust volume level.
Move to the right to increase volume.
Move to the left to decrease volume.

12 BASS EQUALIZER switch/indicator

By pressing this switch ON, the indicator will light and powerful sound reproduction will be obtained.

Use this function as desired when listening to a digital source such as a compact disc.

NOTE:

This function does not operate when the DIRECT CD INPUT switch is in the ON position.

13 DIRECT CD INPUT switch/indicator

Use this switch/indicator when you do not wish to pass the output from a piece of equipment connected to the CD terminals through the various frequency adjusting circuits (BASS, TREBLE, BASS EQUALIZER, BALANCE).

[ON] — When the switch is in this position, the indicator lights and the signals input from the CD terminals are reproduced without passing through the various frequency adjusting circuits.

This results in flat, pure sound which is a more faithful reproduction of the digital source.

[OFF] — When the switch is in this position, the indicator goes out, and the signal selected by the INPUT SELECTOR switches are reproduced.

NOTE:

When this switch is ON, the signals from the source connected to the CD terminals are output from the speaker system, and also the signals from the source selected by the INPUT SELECTOR switch are output from the TAPE1 REC terminal and the ADPTOR/TAPE2 REC terminal. Consequently, if you wish to compensate the sound from the source connected to the CD terminals using recording equipment or an adaptor, press the CD of INPUT SELECTOR switch to select the source connected to the CD terminals.

14 MUTING (-∞) switch/indicator

Use to temporarily cut sound volume.

When depressed ON, the sound volume will be cut off (-∞).

When set to OFF, the sound will return to its previous volume.

15 REMOTE SENSOR/indicator

The accessory remote control unit can also be used to operate this component.

This component features a built-in microcomputer which will recall the last-set positions of the following switches for up to about one week after the power cord is disconnected. As a result, when the power is turned ON again, the previously set positions will be recalled automatically:

- ADPT/TAPE2 switch
- BASS EQUALIZER switch
- DIRECT CD INPUT switch
- INPUT SELECTOR
- POWER ON/STANDBY
- MUTING switch

When the unit is not used for more than a week, the memorized setting positions will be erased, and returned to the following settings:

- POWER switch STANDBY
- MUTING switch OFF
- INPUT SELECTOR switches TUNER
- BASS EQUALIZER ON/OFF switch OFF
- ADPT/TAPE2 switch OFF
- DIRECT CD INPUT switch OFF

4. EXPLODED VIEWS AND PARTS LIST

Exterior

A

B

C

D

A

B

C

D

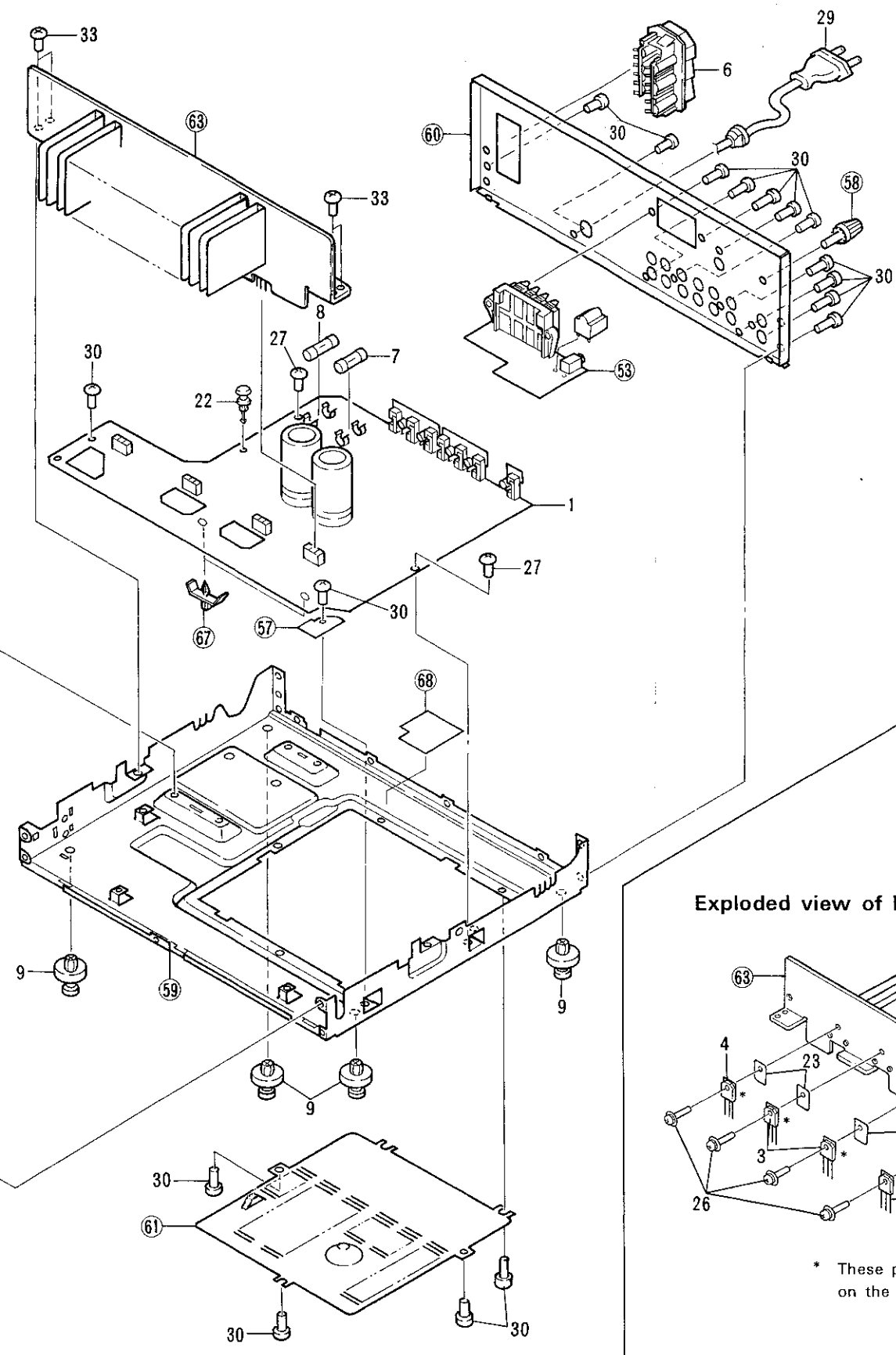
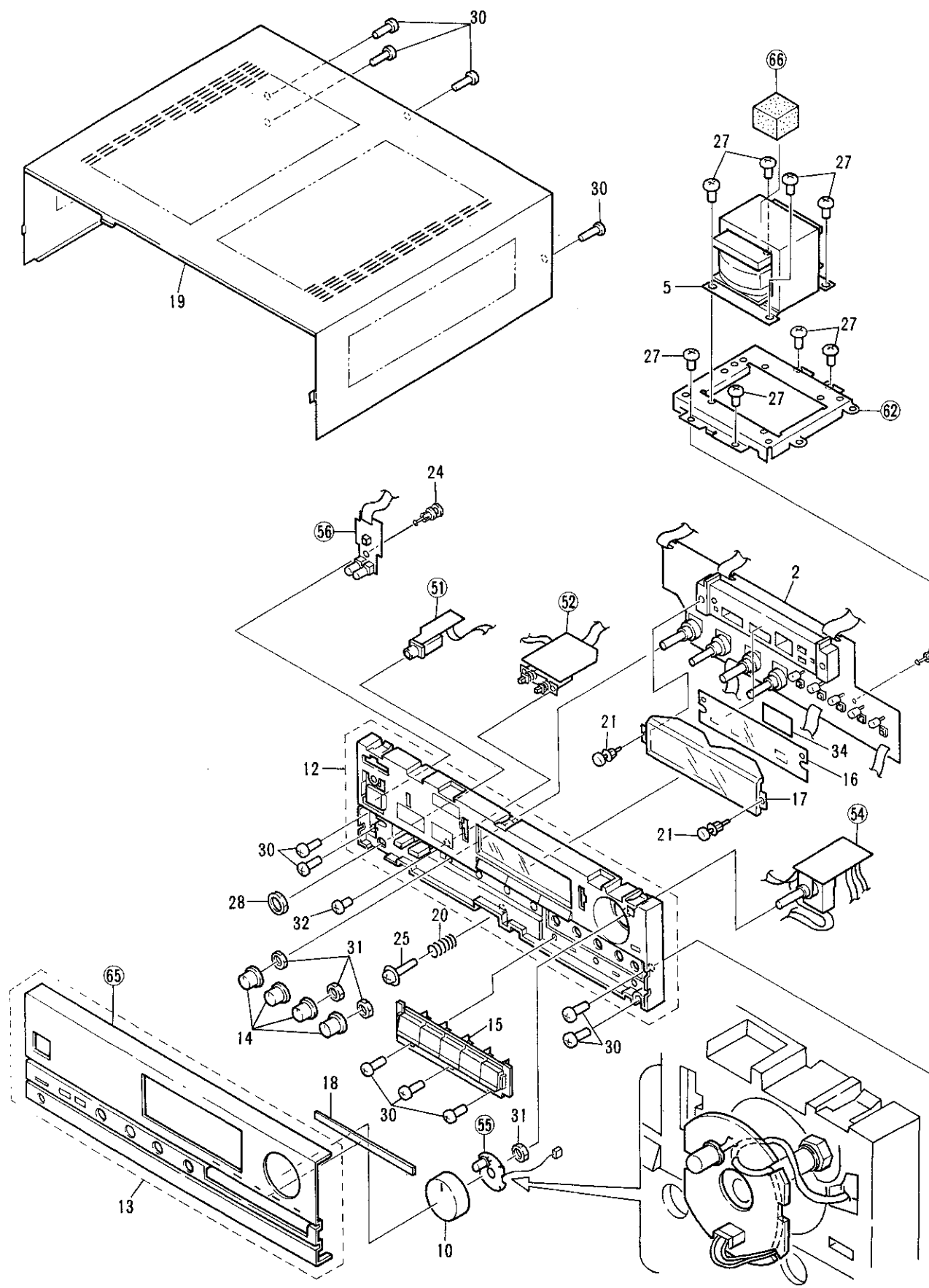

Exploded view of heat sink

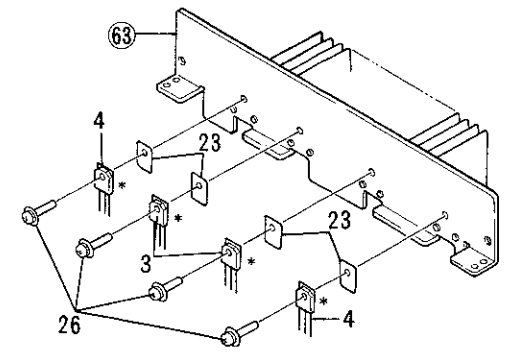

* These parts are mounted on the P.C.board.

Parts
Mark

- **
- **
- △ *
- △ **
- △ **

1

2

3

4

5

6

1

2

3

4

5

6

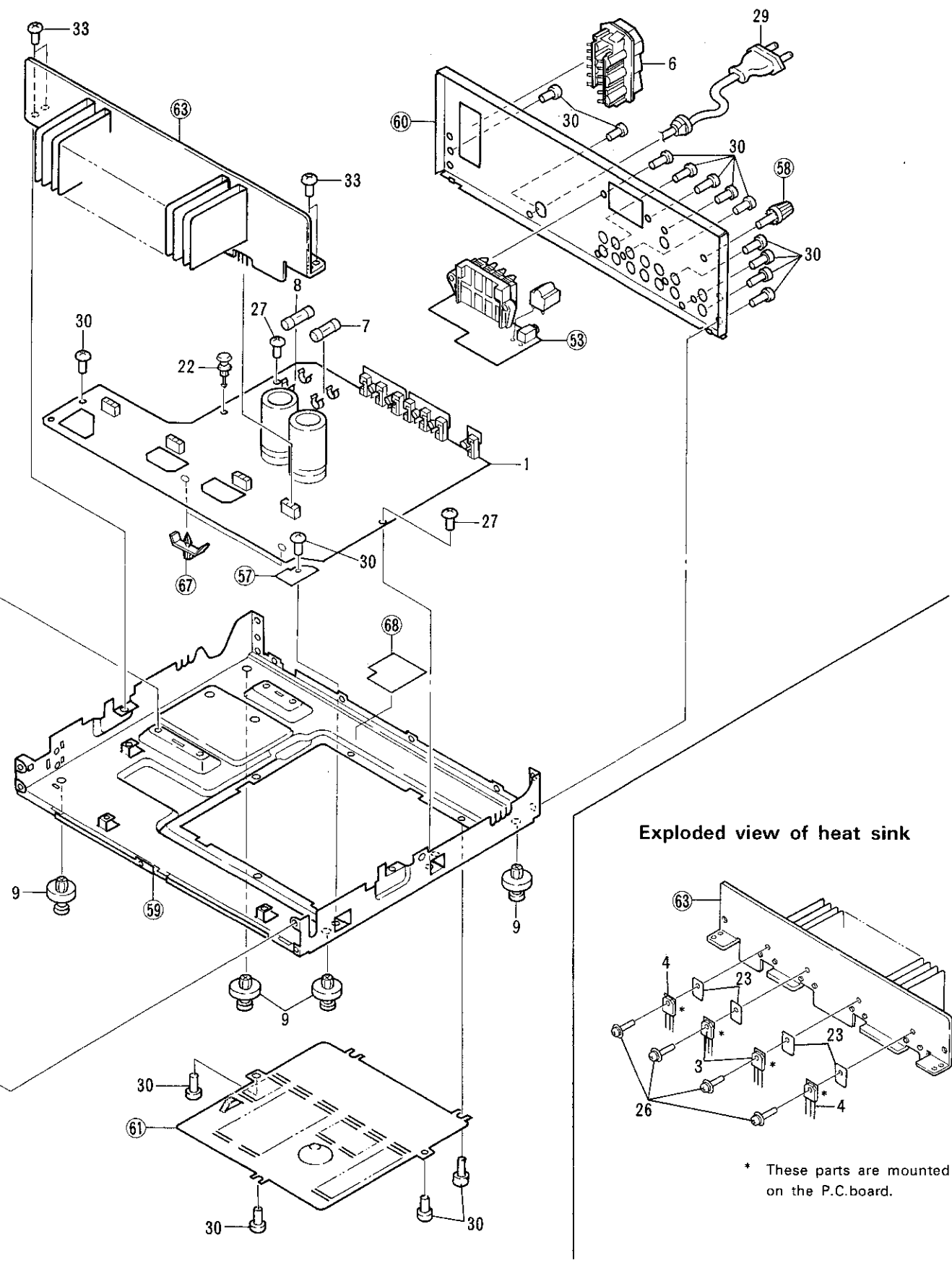

A

B

C

D

NOTES:

- Parts without part number cannot be supplied.
- The Δ mark found on some component parts indicates the importance of the safety factor of the part. Therefore, when replacing, be sure to use parts of identical designation.
- For your parts Stock Control, the fast moving items are indicated with the marks **★★** and **★**.
- **★★ GENERALLY MOVES FASTER THAN ★**
This classification shall be adjusted by each distributor because it depends on model number, temperature, humidity, etc.
- Parts marked by "●" are not always kept in stock. Their delivery time may be longer than usual or they may be unavailable.

Parts List of Exterior

Mark	No.	Part No.	Description	Mark	No.	Part No.	Description
	1	AWZ1409	AF Main Assembly		28	ABN-065	Nut
	2	AWZ1413	Control Main Assembly	Δ	29	ADG1021	AC Power cord
★★	3	2SA1516	Transistor (Q3, Q4)*		30	BBZ30P080	Screw
★★	4	2SC3907	Transistor (Q1, Q2)*			FZK	
Δ ★	5	ATS1082	Power transformer (220V/240V, T1)		31	NK90FUC	Nut
					32	VMZ30P060	Screw
						FMC	
Δ	6	AKP-502	AC Socket 3P (AC OUTLET)		33	ABA-298	Screw
Δ ★	7	AEK-017	Fuse (T2A, FU2)		34	AAK1376	Filter
Δ ★	8	AEK-403	Fuse (T2.5A, FU1)				
	9	AEP-320	Leg assembly		51		Headphone assembly
	10	AAB1034	Knob (MAIN VOLUME)		52		SP SW assembly
	11			53		SP OUT assembly
					54		VR assembly
	12	AMB1208	Panel base assembly		55		LED assembly
	13	ANB1116	Front panel assembly				
	14	AAB1033	Rotary knob (BASS, TREBLE, BASS-EQ, BALANCE)		56		ST-BY assembly
					57		JUMPER assembly
					58		Terminal (GND)
					59		Chassis
	15	AAD1161	Function knob (ADAPTOR, TAPE1, TUNER, CD, PHONO)		60		Rear panel
	16	AAK1389	Display sheet		61		Bottom plate
	17	AAK1278	Display plate		62		Transformer holder
					63		Heat sink
	18	AMR1162	Indicator Lens		64	
	19	ANE1074	Bonnet case		65		Front panel
	20	ABH1032	Coil spring				
	21	AEC-384	Nylon rivet		66		Cushion rubber
	22	AEC-525	Nylon rivet		67		Spacer
					68		Balire
	23	AEC-818	Mica sheet				
	24	AMR1066	Plastic rivet				
	25	ABA-252	Screw				
	26	ABA-297	Screw				
	27	ABA1011	Screw				

Exploded view of heat sink

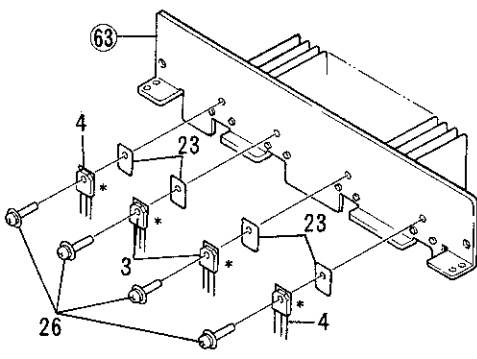

* These parts are mounted on the P.C. board.

4

5

6

6

7

5. SCHEMATIC DIAGRAM

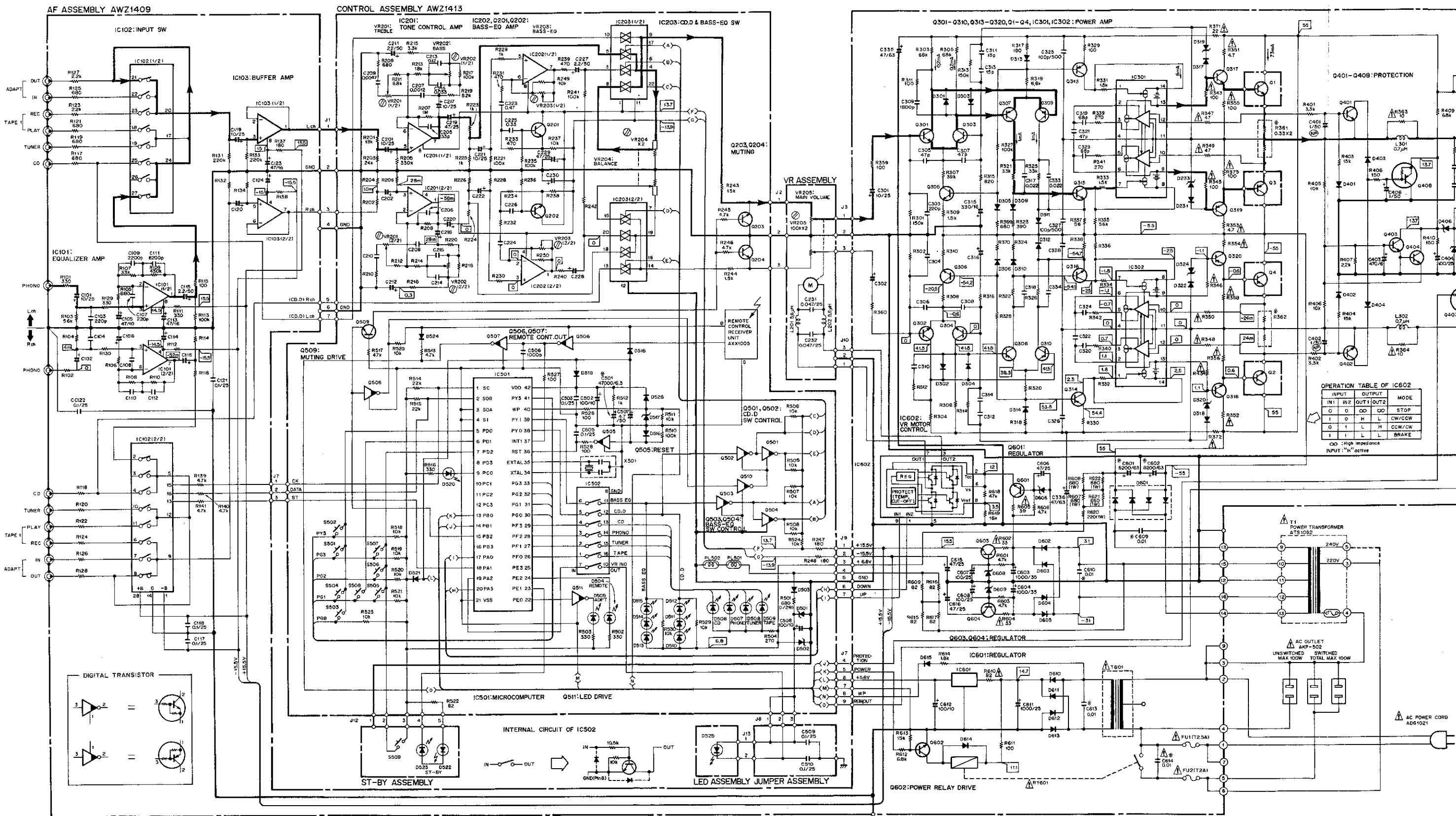

6. P.C. BOARDS CONNECTION DIAGRAM

A

B

C

D

AF ASSEMBLY AWZ1409

CONTROL ASSEMBLY AWZ1413

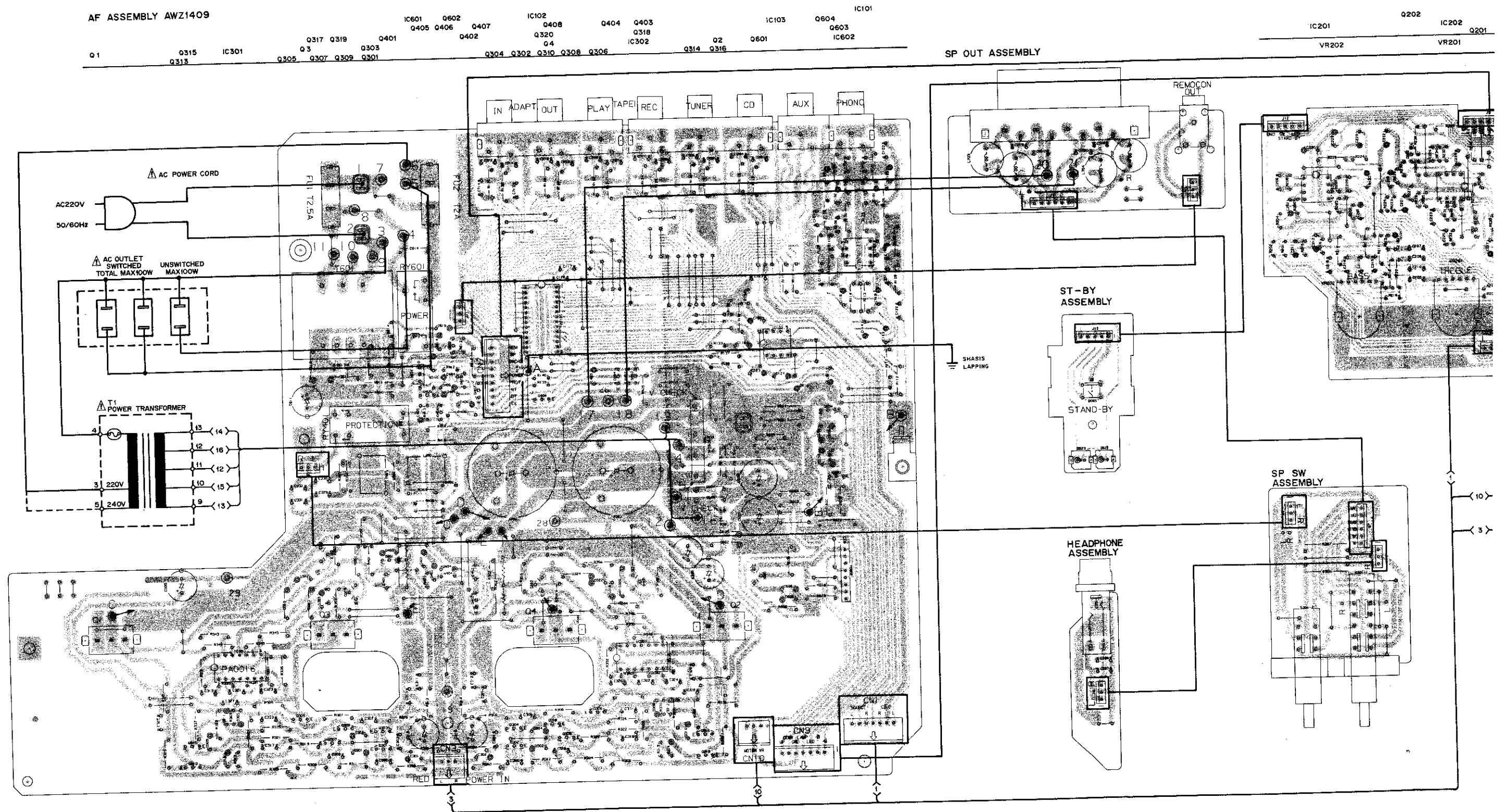

1

2

3

4

5

6

W MBL Y

IC201 Q202 IC202 Q201 Q503 Q504 Q501 Q502 Q505 Q506 Q507 Q508 Q509 Q204 Q203 Q511 IC501 IC502
VR202 VR201 VR203 VR204

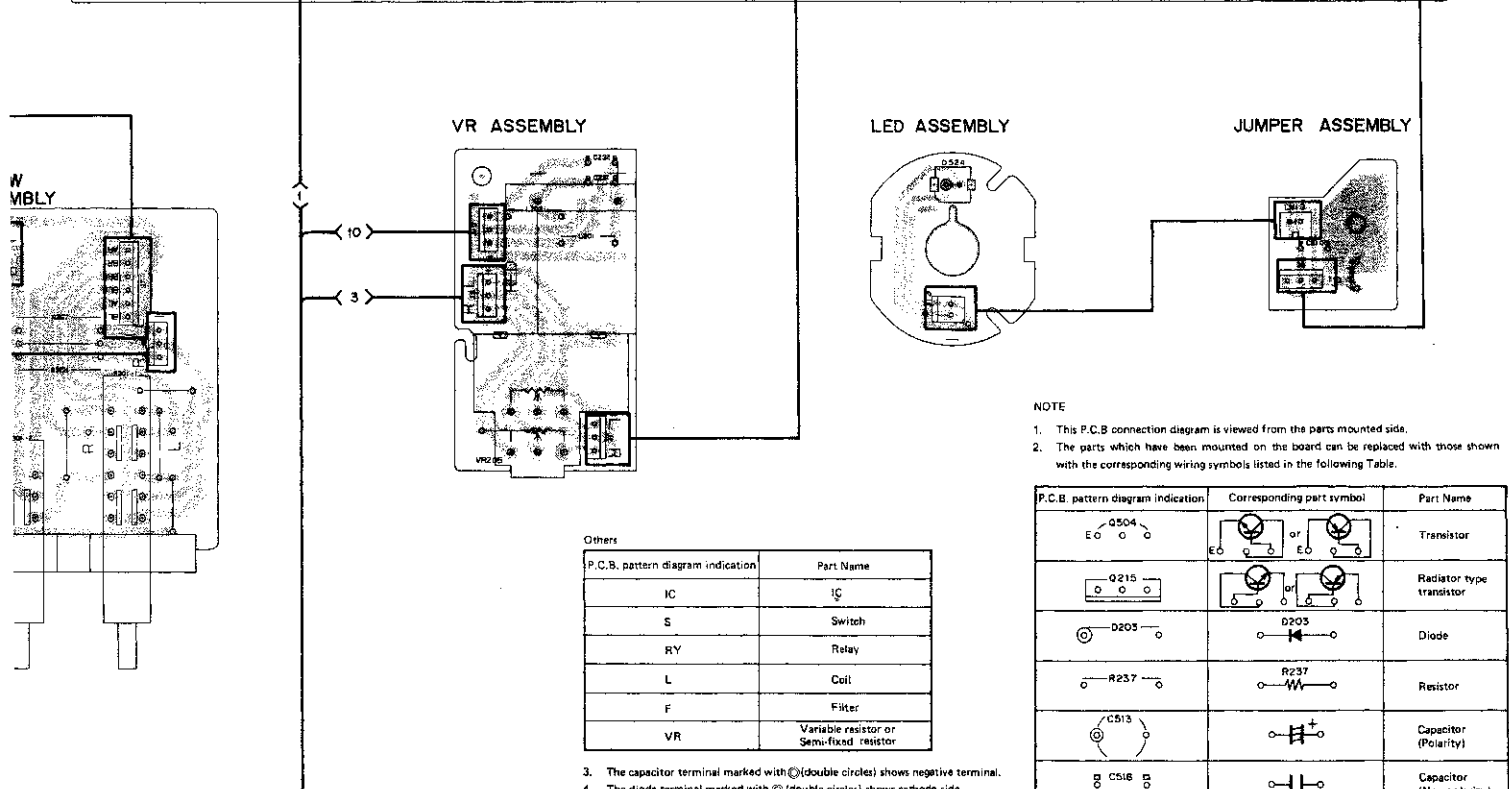
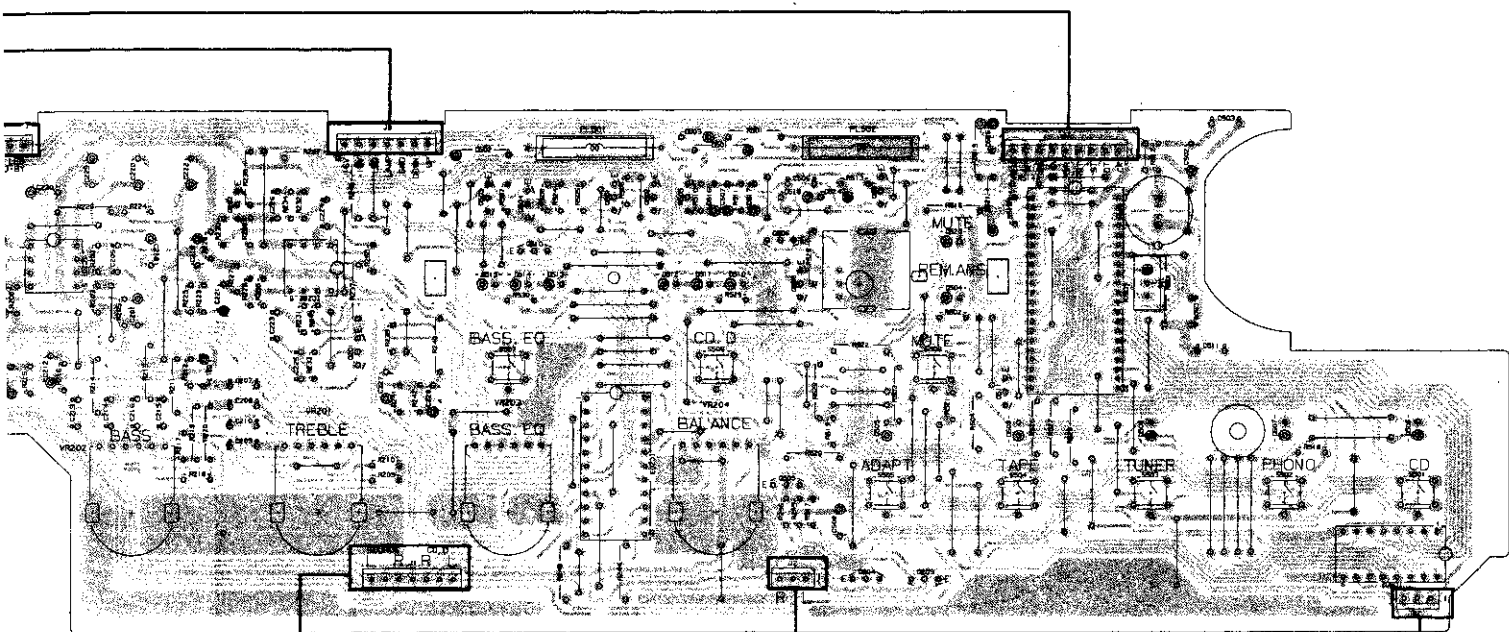

Others

P.C.B. pattern diagram indication	Part Name
IC	IC
S	Switch
RY	Relay
L	Coil
F	Filter
VR	Variable resistor or Semi-fixed resistor

- The capacitor terminal marked with (C) (double circles) shows negative terminal.
- The diode terminal marked with (D) (double circles) shows cathode side.
- The transistor terminal to which E is affixed shows the emitter.

NOTE

- This P.C.B. connection diagram is viewed from the parts mounted side.
- The parts which have been mounted on the board can be replaced with those shown with the corresponding wiring symbols listed in the following Table.

P.C.B. pattern diagram indication	Corresponding part symbol	Part Name
Q504	Q or Q	Transistor
Q215	Q or Q	Radiator type transistor
D205	D	Diode
R257	R	Resistor
C513	C	Capacitor (Polarity)
C518	C	Capacitor (Non-polarity)

External appearance of transistors and ICs

2SA933S
2SC1740S

2SA1145
2SC2240
2SC2705
2SC2878

LB1214

2SA1516
2SC3907

2SA968
2SC2238
2SD880

2SA1346
2SC3400
RN1201
RN1203
RN2201
RN2203

M5218P
M5218PF

TA7291S

2SA992
2SB560
2SC1845

2SD438

M5278L56(A)

PDG009

2SA1048
2SC2458

DTA124ES
DTA143ES
DTC143ES

PA0016

2SA1115
2SC2603

JA101
JC501

TC9163N

A
B
C
D

7. ELECTRICAL PARTS LIST

NOTES:

- Parts without part number cannot be supplied.
 - Parts marked by "⊙" are not always kept in stock. Their delivery time may be longer than usual or they may be unavailable.
 - The Δ mark found on some component parts indicates the importance of the safety factor of the part. Therefore, when replacing, be sure to use parts of identical designation.
 - For your parts Stock Control, the fast moving items are indicated with the marks ★★ and ★.
 - ★★ **GENERALLY MOVES FASTER THAN ★**
 - This classification shall be adjusted by each distributor because it depends on model number, temperature, humidity, etc.
 - When ordering resistors, first convert resistance values into code form as shown in the following examples.
- Ex. 1 When there are 2 effective digits (any digit apart from 0), such as 560 ohm and 47k ohm (tolerance is shown by J = 5%, and K = 10%).
- 560Ω 56 × 10¹ 561.....RD1/4PS ⊕ ⊕ ⊕ J
 47kΩ 47 × 10³ 473.....RD1/4PS ⊕ ⊕ ⊕ J
 0.5Ω 0R5.....RN2H ⊕ ⊕ ⊕ K
 1Ω 010.....RSIP ⊕ ⊕ ⊕ K
- Ex. 2 When there are 3 effective digits (such as in high precision metal film resistors).
- 5.62kΩ 562 × 10¹ 5621.....RN1/4SR ⊕ ⊕ ⊕ F

Miscellaneous Parts P.C BOARD ASSEMBLIES

Mark	Symbol & Description	Part No.
Δ ⊙	AF main assembly	AWZ1409
⊙	Control main assembly	AWZ1413
	VR assembly	
	LED assembly	
	ST-BY assembly	
	Jumper assembly	
	Headphone assembly	
	SP SW assembly	
	SP OUT assembly	

OTHERS

Mark	Symbol & Description	Part No.
★★	Q3, Q4 Transistor	2SA1516
★★	Q1, Q2 Transistor	2SC3907
Δ ★	T1 Power transformer (AC220/240V)	ATS1082
Δ	AC Socket 3P (AC OUTLET)	AKP-502
Δ ★★	FU2 Fuse (T2A)	AEK-017
Δ ★★	FU1 Fuse (T2.5A)	AEK-403
Δ	AC power cord	ADG1021

Δ ⊙ AF main assembly (AWZ1409) SEMICONDUCTORS

Mark	Symbol & Description	Part No.
★★	IC101	M5218P
★★	IC103	M5218PF
★★	IC601	M5278L56 (A)
★★	IC301, IC302	PA0016
★★	IC602	TA7291S
★★	IC102	TC9163N
★★	Q301—Q306, Q401, Q402	2SC1845
★★	Q307—Q310	2SA992

Mark	Symbol & Description	Part No.
★★	Q313, Q314	2SA1145
★★	Q315, Q316	2SC2705
★★	Q317, Q318	2SC2238
★★	Q319, Q320	2SA968
★★	Q403, Q404	2SC2458 (JC501) (2SC1740S) (2SC2603)
★★	Q405	2SA1048 (JA101) (2SA1115) (2SA933S)
★★	Q406, Q602, Q603	2SD438
★★	Q407	RN1203 (2SC3400)
★★	Q408	RN2203 (DTA124ES) (2SA1346)
★★	Q601	2SD880
★★	Q604	2SB560
★	D601	D5SB20F
★	D406	RD13ESB
★	D606	RD13ESB1
★	D608, D609	RD16ESB3
★	D319, D320, D323, D324	RD4.7EB (HZ4.7EB)
★	D405	RD5.6ESB
★	D301—D306, D309—D314, D317, D318, D321, D322, D401—D404, D614, D615	1SS131
★	D602—D605, D610—D613	11E2 (S5566)

RELAYS

Mark	Symbol & Description	Part No.
★★	RY401 (PROTECTION)	ASR-112
Δ ★★	RY601 (POWER)	ASR-512

COILS & TRANSFORMER

Mark	Symbol & Description	Part No.
	L301, L302 AF choke coil (0.7μH)	ATH1011
Δ ★	T601 Power transformer (AC110,120—127/220, 240V)	ATT1015

CAPACITORS

Mark	Symbol & Description	Part No.
Δ	C614 (0.01μF/ V)	ACG1002
	C609, C610, C613 (0.01μF/ V)	ACG1005
	C601, C602 (8200μF/63V)	ACH1044
	C325—C328	CCCSL101K500
	C311—C314	CCCSL150J50
	C103, C104, C107, C108, C303, C304	CCCSL221J50
	C305—C308, C321, C322	CCCSL470J50
	C319, C320, C323, C324	CCCSL680J50
	C401, C402	CEANP010M50
	C405	CEAS010M100
	C406	CEAS010M50
	C101, C102, C119, C120	CEAS100M25
	C612	CEAS101M10
	C404, C607, C608	CEAS101M25
	C611	CEAS102M25
	C603, C604	CEAS102M35
	C115, C116	CEAS2R2M50
	C105, C106	CEAS470M10
	C113, C114, C123, C124	CEAS470M16
	C606	CEAS470M25
	C403	CEAS471M6
	C301, C302	CEYA100M25
	C315, C316	CEYA331M16
	C335, C336	CEYA470M63
	C615, C616	CEYA470M25
	C317, C318, C333, C334	CFTXA223J50
	C329—C332	CFTXA823J50
	C309, C310	CKCYB182K50
	C117, C118, C121, C122	CKCYX104M25
	C109, C110	CQMA222J50
	C111, C112	CQMA882J50

RESISTORS

Mark	Symbol & Description	Part No.
	R361, R362 Resistor array (0.33ΩX2)	ACN—139
Δ	R313, R314	RDR1/4PM154J
Δ	R365, R366, R371, R372, R610	RD1/4PMFL□□□J
Δ	R343—R350, R355—R358, R363, R364	RD1/4PMF□□□J

Mark	Symbol & Description	Part No.
Δ	R351—R354, R602, R604, R605	RFA1/4PS□□□J
	R607, R608, R620—R622	RS1LMF□□□J
	R103, R104, R131—R134, R139—R141, R317, R318, R339—R342, R369, R370, R403—R407, R410—R413, R612—R614, R618, R619	RD1/8PM□□□J
	Other resistors	RD1/4PM□□□J

OTHERS

Mark	Symbol & Description	Part No.
	Pin-jack 6P (ADAPTER IN/OUT, TAPE 1 REC/PLAY, TUNER, CD)	AKB—117
	Pin-jack 2P (PHONO)	AKB—119
	Transistor socket	AKH—017

⊙ Control main assembly (AWZ1413) SEMICONDUCTORS

Mark	Symbol & Description	Part No.
★★	IC201, IC202	M5218PF
★★	IC203	μPD6362C
★★	IC501	PDG009
★★	IC502	LB1214
★★	Q201, Q202	2SC1845 (2SC2240)
★★	Q203, Q204	2SC2878
★★	Q501—Q504, Q510, Q511	RN1203 (2SC3400)
★★	Q505, Q507, Q508	RN1201 (DTC143ES)
★★	Q506	RN2201 (DTA143ES)
★★	Q509	2SA1048 (JA101) (2SA1115) (2SA933S)
★	D501	RD3.0ESB
★	D502	RD6.8EB (HZ6.8EB)
★	D517	RD4.7ESB
★	D510—D515	AEL1030
★	D504, D520	AEL1031
★	D506—D509	AEL1032
★	D505	AEL1049
★	D503, D516, D518, D519, D521, D524, D526	1SS131

SWITCHES

Mark	Symbol & Description	Part No.
★★	S501—S508 Tact switch (CD/PHONO/TUNER/TAPE/ADAPTER/CD. D/BASS-EQ/MUTE)	ASG-711 (ASG-703)

CAPACITORS

Mark	Symbol & Description	Part No.
	C501 (47000μF/6.3V)	ACH1037
	C205, C206	CCCSL330J50
	C201, C202, C217, C218, C221, C222	CEAS100M25
	C502, C508	CEAS101M10
	C211, C212	CEAS2R2M50
	C507	CEAS4R7M50
	C219, C220, C229, C230	CEAS470M25
	C227, C228	CEJA2R2M50
	C225, C226	CFTXA334J50
	C223, C224	CFTXA474J50
	C506	CKCYB102K50
	C503, C505	CKCYX104M25
	C207, C208	CQMA122K50
	C213, C214	CQMA124K50
	C215, C216	CQMA333K50
	C209, C210	CQMA472K50

RESISTORS

Mark	Symbol & Description	Part No.
*	VR204 10kx2 (BALANCE)	ATC1025
*	VR203 5kx2 (BASS-EQ)	ATC1026
*	VR201, VR202 100kx2 (BASS, TREBLE)	ATC1029
	R501	RD1/2PM681J
	R243, R244, R247, R248, R504, R522	RD1/4PM□□□J
	Other resistors	RD1/8PM□□□J

OTHERS

Mark	Symbol & Description	Part No.
	PL501, PL502 Pilot lamp	AEL-175
	X501 Ceramic oscillator	ASS1010
	Remote control receiver unit	AXX1005

**VR assembly
INDUCTORS**

Mark	Symbol & Description	Part No.
	L201, L202 (5.6μH)	ATH-065

CAPACITORS

Mark	Symbol & Description	Part No.
	C231, C232	CKCYX473M25

RESISTOR

Mark	Symbol & Description	Part No.
*	VR205 100kx2w/Motor (MAIN VOLUME)	ACX1004

**LED assembly
SEMICONDUCTOR**

Mark	Symbol & Description	Part No.
*	D525	AEL1003

**ST-BY assembly
SEMICONDUCTORS**

Mark	Symbol & Description	Part No.
*	D522, D523	AEL1004

SWITCH

Mark	Symbol & Description	Part No.
**	S509 Tact switch (ST-BY)	ASG-711 (ASG-703)

**Jumper assembly
CAPACITORS**

Mark	Symbol & Description	Part No.
	C509, C510	CKCYX104M25

**Headphone assembly
OTHER**

Mark	Symbol & Description	Part No.
	Jack (PHONES)	AKN1002

**SP SW assembly
SWITCH**

Mark	Symbol & Description	Part No.
**	S301 Push switch (SP A/B)	SUL8LXYS

RESISTORS

Mark	Symbol & Description	Part No.
Δ	R367, R368	RS2LMF331J

**SP OUT assembly
OTHERS**

Mark	Symbol & Description	Part No.
	Terminal board 8P (SPEAKERS L/R)	AKE-111
	Mini-jack (REMOTE CONTROL OUT)	AKN-207

8. FOR HB AND SD TYPES

8.1 SCHEMATIC DIAGRAM

Schematic diagram for HB type

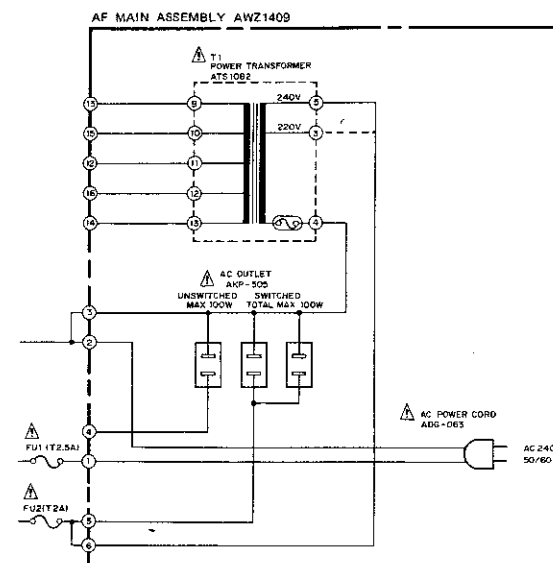

Schematic diagram for SD type

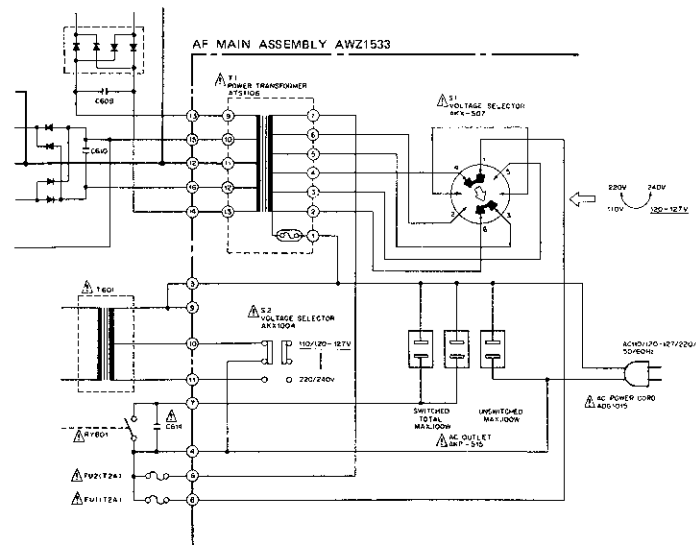

Line Voltage Selection for HE and HB types

1. Disconnect the AC power cord.
2. Remove the bonnet case.
3. Change the connection wire to transformer (ATS1082) from AF MAIN assembly as follows.

	Terminal No. of transformer
220V	3
240V	5

4. Stick the line voltage label on the rear panel.

Description	Part No.
220V label	AAX-193
240V label	AAX-192

Change of line Voltage for SD type

Be sure to switch both S1 and S2 selector switches.

1. Using a medium-size screwdriver, turn the switch S1 to the position of desired voltage (Fig. A).
2. Change the position of switch S2 accordingly to the above voltage (Fig. B).

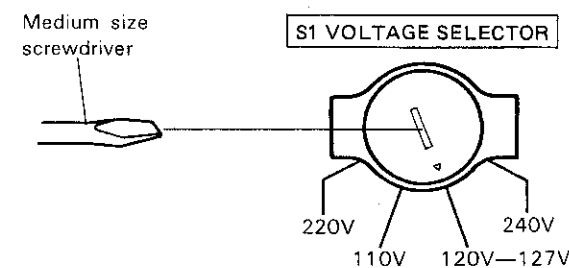

Fig. A

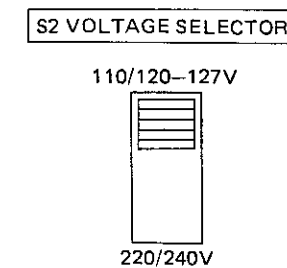

Fig. B

8.2 CONTRAST OF MISCELLANEOUS PARTS

NOTES:

- Parts without part number cannot be supplied.
- The \triangle mark found on some component parts indicates the importance of the safety factor of the part. Therefore, when replacing, be sure to use parts of identical designation.
- For your parts Stock Control, the fast moving items are indicated with the marks **★★** and **★**.
★★ GENERALLY MOVES FASTER THAN ★
 This classification shall be adjusted by each distributor because it depends on model number, temperature, humidity, etc.
- Parts marked by "●" are not always kept in stock. Their delivery time may be longer than usual or they may be unavailable.

CONTRAST OF MISCELLANEOUS PARTS

The A-X530/HB and SD types are the same as the A-X530/HE type with the exception of the following sections.

Mark	Symbol & Description	Part No.			Remark
		A-X530/ HE type	A-X530/ HB type	A-X530/ SD type	
\triangle	AC power cord	ADG1021	ADG-063	ADG1015	
\triangle ★★	FU2 Fuse (T2A)	AEK-017	AEK-511	AEK-017	
\triangle ★★	FU1 Fuse (T2.5A)	AEK-403	AEK-512	
\triangle ★★	FU1 Fuse (T2A)	AEK-017	
\triangle	AC socket 3P (AC OUTLET)	AKP-502	AKP-505	AKP-515	
	Operating instructions (English)	ARB1080	ARB1080	
	Operating instructions (English/German/French/Italian)	ARE1051	
\triangle ★	T1 Power transformer (AC220/240V)	ATS1082	ATS1082	
\triangle ★	T1 Power transformer (AC110/120-127/220/240V)	ATS1106	
\triangle	AF main assembly*	AWZ1409	AWZ1409	AWZ1533	
\triangle ★★	S1 Voltage selector (110/120-127/220/240V)	AKX-507	
\triangle ★★	S2 Voltage selector (110, 120-127/220, 240V)	AKX1004	

* Marked P.C. board assemblies:

Regard less differences on parts numbers, the P.C. board assemblies for the additional types are identical with the HE type.

9. PACKING

Parts List of Packing

Mark	No.	Part No.	Description
	1	ADE-085	Connection cord
	2	ARE1051 (HE type)	Operating instructions (English/French/ German/Italian)
		ARB1080	Operating instructions (HB, SD type) (English)
	3	AXD1024	Remote control unit
	4	AHA1069	Pad (Front, Rear)
	5	AHD1232	Packing case
	51		Battery
	52		Packing sheet
	53		Catalogue bag

