

FOR BELGIAN, FRENCH AND
WESTERN EUROPEAN MODEL

 Set using ISO Screws

TV9-90UM 266

Serial No. 40,501 and later



SPECIFICATIONS

Picture tube: 9" 90° deflection aluminized screen; 230DB4

Channel coverage: VHF; French F2, F4 - F12
CCIR Western European, Belgian E2 - E12
Italian B(E-4), D(E-5), H(E-10)

Antenna system: UHF; CCIR and French 21-69
Built-in telescopic antenna
Terminals for 75 ohm external antenna

Tuner: Disc turret type for VHF band (BT-435M)
Continuous tuning type for UHF band (BT-186)

IF circuit: 3 stages with 4 stagger tuned elements
Video bandwidth; 3.8 MHz/-3 dB

Transistors: 32
Diodes: 17
IC: 1
Power rectifier: 1 (selenium)
High voltage rectifiers: 3 (selenium)
Sound system: 5.5 MHz intercarrier
Separate systems (Can be selected by push button provided in the set)
Power amplifier; OTL system
Power output; 300 mW
Speaker; 2 3/4" x 3 15/16" oval type, 40 ohms

REC OUT jack: Impedance 1k ohm, level -60 dB (0.78 mV)

Automatic controls: Forward AGC (VHF tuner & VIF), Reverse AGC (SIF) and Single pulse AFC

Power requirements & consumptions: AC 110, 130, 220 volts, 50/60 Hz
21.5W (maximum)
DC 12 volts 13.0W (maximum)

Dimensions: 8 13/16" (W) x 10 1/2" (H) x 9 5/8" (D)
(224 x 266 x 245 mm)

Weights: 12 lb (5.6 kg)

		Video IF (AM)	Sound IF (AM)
Intercarrier system	CCIR	38.9 MHz	33.4 MHz
	French VHF French UHF	38.9 & 34.9 38.9	27.75 & 46.05 32.4
Separate-carrier system	Belgian (625 lines)	38.9	33.4
	Belgian (819 lines)	38.9	

SONY®

SERVICE MANUAL

TABLE OF CONTENTS

Title	Page	Title	Page
Specification for the TV9-90UM	1	SCHMATIC DIAGRAM	
BLOCK DIAGRAM	2	Tuner circuit	17
EXTERNAL VIEW	3	Signal circuit	21
MAJOR PARTS LOCATION	4	FM SIF circuit	25
DISASSEMBLY		Power supply block	26
Rear Cabinet Removal	5	Deflection circuit	27
Glare Filter Removal	5	MOUNTING DIAGRAM	
Deflection Circuit Block Removal	6	Conductor Side	
High Voltage Block Removal	7	Tuner circuit	18
Signal Circuit Board Removal	7	Signal circuit	19
FM SIF Block Removal	9	FM SIF circuit	25
UHF Tuner Removal	9	Deflection circuit	29
VHF Tuner Removal	10	Component Side	
Picture Tube Removal	11	Tuner circuit	18
Speaker Removal	11	Signal circuit	23
ADJUSTMENTS PROCEDURE		FM SIF circuit	25
VIF Adjustments	11	Deflection circuit	31
SIF Adjustments	13	Power supply block	26
AM-SIF Adjustments	13	SCHMATIC DIAGRAM	
Deflection Circuit Adjustments	15	Overall	32
TERMINAL VIEW		EXPLODED VIEW	35
Semiconductor	16	PACKING	41

BLOCK DIAGRAM

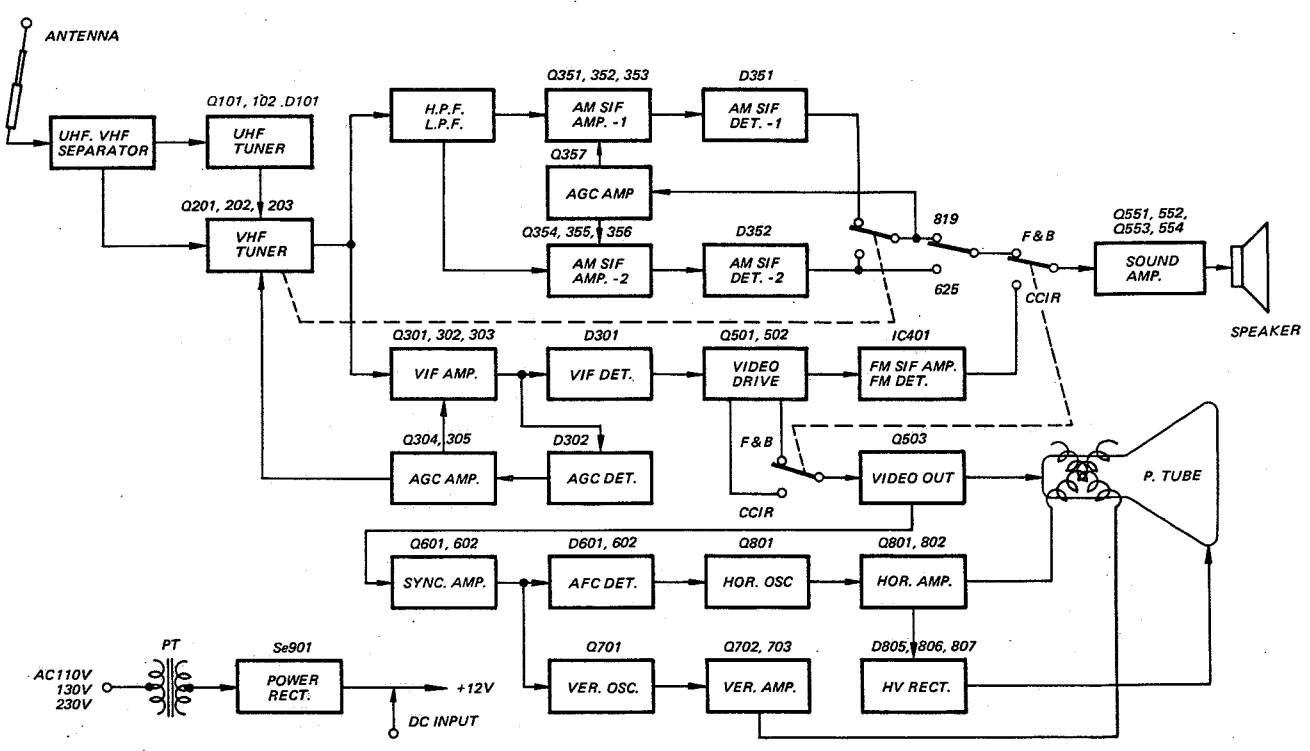

SONY®

Complete Spare Parts List

Model **TV9-90UM**

(Serial No. 40,501 and later)

"IMPORTANT"

When ordering parts, please do not fail to furnish us the following:

1. Part Number
2. Model Name
3. Description as mentioned in this parts list

We are now using EDPS (Electronic Data Processing System) in all the departments concerned, for procurement, inventory control, packing, warehousing, etc. Your orders are processed mainly from the PART NUMBERS referred by you. Incorrect part numbers, therefore, will result in incorrect parts shipment. To assure prompt shipment of correct parts, your cooperation will be appreciated.

NOTE:

Prices are subject to change without notice.

COMPLETE SPARE PARTS LIST FOR TV9-90UM

(Serial No. 40,501 and later)

JANUARY, 1972

<u>Part No.</u>	<u>Description</u>	<u>Unit Price</u>
I. <u>MECHANICAL PARTS</u>		
X-40128-01	Cabinet Ass'y, front -----	
X-40128-02	Knob Ass'y, channel -----	
X-40128-03	Knob Ass'y, fine tuning -----	
X-40128-04	Cabinet Ass'y, rear -----	
X-40128-05	Clamp Ass'y, power cord -----	
X-40032-04	Mounting Bracket Ass'y, picture tube -----	
X-40062-16	Knob Ass'y, VOL control -----	
X-40074-07	Knob Ass'y, UHF dial -----	
X-40097-05-2S	Handle Support Ass'y, left -----	
X-40097-06-2S	Handle Support Ass'y, right -----	
X-40097-07	UHF Dial Ass'y -----	
X-40097-09	Shield Plate Ass'y, video out -----	
4-012-808	Mounting Bracket, pushbutton switch -----	
4-012-809	Mounting Bracket, signal circuit board -----	
4-012-810	Shield Case -----	
4-012-811	Shield Cover -----	
4-012-813	Holder, selenium rectifier -----	
0-051-221	Spacer, pushbutton switch -----	
3-001-706	Clamp, cord -----	
4-002-847-02	Clamp, antenna -----	
4-003-220	Grounding Spring, picture tube -----	
4-003-506	Drive Screw -----	
4-005-359	Clamp, lead -----	
4-005-556	Shield Plate, cushion -----	
4-005-565	Cushion, picture tube -----	
4-006-103-04S	Support, power transformer -----	
4-006-233	Control Knob -----	
4-006-255	Terminal Pin -----	
4-007-208	Spacer -----	
4-007-411	Mounting Bracket, picture tube -----	
4-007-455	Mounting Wire Ring, picture tube -----	
4-009-724	Protector, picture tube -----	
4-009-725	Hold, protector -----	
4-009-726	Carrying Handle -----	
4-009-729-02S	Screw, handle -----	

<u>Part No.</u>	<u>Description</u>	<u>Unit Price</u>
4-009-728	Pushbutton -----	
4-009-729-06S	Mounting Bracket, tuner -----	
4-009-730-02S	Support, tuner bracket -----	
4-009-733	Mounting Wire, speaker -----	
4-009-734	Mounting Plate, volume control -----	
4-009-735	Clamp, electrolytic capacitor -----	
4-009-736-02S	Mounting Bracket, deflection circuit board -----	
4-009-739	Connection Plate, cabinet -----	
4-009-740-03S	Mounting Plate, antenna -----	
4-009-741-04S	Heat Sink, horizontal output transformer -----	
4-009-759	Dust Proof Protector, cushion -----	
4-011-457	Shield Case, SIF block; upper -----	
4-011-458	Shield Case, SIF block; lower -----	
4-011-437	Heat Sink -----	
	<u>II. MOUNTING HARDWARE</u>	
7-621-259-48	Screw, (+) P 2.6 x 6 -----	
7-621-259-69	Screw, (+) P 2.6 x 10 -----	
7-621-721-87	Self-tapping Screw, (+) K 2.6 x 8 -----	
7-621-722-57	Self-tapping Screw, (+) BV 3 x 8 -----	
7-621-722-63	Self-tapping Screw, (+) BV 3 x 10 -----	
7-621-722-99	Self-tapping Screw, (+) BV 3 x 16 -----	
7-621-724-45	Self-tapping Screw, (+) BV 4 x 10 -----	
7-682-145-01	Screw, (+) P 3 x 4 -----	
7-682-147-01	Screw, (+) P 3 x 6 -----	
7-682-149-12	Screw, (+) P 3 x 10 -----	
7-682-161-13	Screw, (+) P 4 x 8 -----	
7-682-198-01	Screw, (+) P 3 x 50 -----	
7-682-646-01	Screw, (+) PS 3 x 5 -----	
7-623-108-12	Washer, 3 mm dia. -----	
7-623-112-12	Washer, 5 mm dia. -----	
7-623-207-22	Washer, spring; 2.6 mm dia. -----	
7-623-208-22	Washer, spring; 3 mm dia. -----	
7-623-210-28	Washer, spring; 4 mm dia. -----	
7-623-408-05	Washer, external tooth; 3 mm dia. -----	
7-623-508-01	Terminal Lug, 3 mm dia. -----	
7-684-013-01	Nut, 3 mm dia. -----	
7-684-014-01	Nut, 4 mm dia. -----	

<u>Ref. No.</u>	<u>Part No.</u>	<u>Description</u>	<u>Unit Price</u>
-----------------	-----------------	--------------------	-------------------

III. ELECTRICAL PARTS

General

8-980-155-15	VHF Tuner Ass'y (BT-435M) -----
1-463-004	UHF Tuner Ass'y (BT-186) -----
8-980-159-25	Signal Circuit Board (BC), complete -----
8-980-159-35	Deflection Circuit Board (EF), complete -----
8-980-159-95	FM Sound IF Circuit Board (FM, SIF), complete -----

Semiconductors

Q301	Transistor, 2SC657 -----
Q302	Transistor, 2SC657 -----
Q303	Transistor, 2SC629 -----
Q304	Transistor, 2SC633 -----
Q305	Transistor, 2SA677 -----
Q351	Transistor, 2SC629 -----
Q352	Transistor, 2SC657 -----
Q353	Transistor, 2SC629 -----
Q354	Transistor, 2SC629 -----
Q355	Transistor, 2SC657 -----
Q356	Transistor, 2SC629 -----
Q357	Transistor, 2SC633 -----
Q501	Transistor, 2SC403A -----
Q502	Transistor, 2SC403A -----
Q503	Transistor, 2SC1127 -----
Q551	Transistor, 2SC403 -----
Q552	Transistor, 2SB324 -----
Q553	Transistor, 2SD72 -----
Q554	Transistor, 2SB324 -----
Q601	Transistor, 2SA182 -----
Q602	Transistor, 2SC633 -----
Q701	Transistor, 2SC633 -----
Q702	Transistor, 2SA677 -----
Q703	Transistor, 2SD292 -----
Q801	Transistor, 2SC403A -----
Q802	Transistor, 2SD292 -----
Q803	Transistor, 2SC806A -----
D301	Diode, 1T261 -----
D302	Diode, 1T261 -----

<u>Ref. No.</u>	<u>Part No.</u>	<u>Description</u>	<u>Unit Price</u>
D353		Diode,	1T261 -----
D354		Diode,	1T261 -----
D501		Diode,	1T243 -----
D601		Diode,	1T22A -----
D602		Diode,	1T22A -----
D701		Diode,	1T22A -----
D702		Diode,	1T22A -----
D801		Diode,	1T22A -----
D802		Diode,	SB-2 -----
D803		Diode,	HFSD-1Z -----
D804		Diode,	HFSD-1Z -----
D808		Diode,	HFSD-1A -----
Th301	8-690-003	Thermistor,	S-90 -----
Th551	8-690-003	Thermistor,	S-90 -----
IC401	8-759-101-60	IC,	μ PC-16C -----

Coils

L301	1-409-153	40.4 MHz, trap	-----
L302	1-409-150	33.4 MHz, trap	-----
L305	1-407-184	3.3 μ H, micro inductor	-----
L306	1-407-177	470 μ H, micro inductor	-----
L307	1-407-177	470 μ H, micro inductor	-----
L308	1-407-177	470 μ H, micro inductor	-----
L360	1-407-184	3.3 μ H, micro inductor	-----
L361	1-407-184	3.3 μ H, micro inductor	-----
L501	1-407-178	1 μ H, micro inductor	-----
L502	1-407-159	15 μ H, micro inductor	-----
L504	1-407-174	270 μ H, micro inductor	-----
L505	1-407-173	220 μ H, micro inductor	-----
L701	1-421-127	Choke Coil, vertical output	-----
L801	1-421-013	25 μ H, micro inductor	-----

4/16 (TV9-90UM)

(TV9-9-3)

<u>Ref. No.</u>	<u>Part No.</u>	<u>Description</u>	<u>Unit Price</u>
L802	1-407-366	1.7 μ H, coil, RF choke -----	
L803	1-407-366	1.7 μ H, coil, RF choke -----	
L804	1-407-220	2.2 μ H, micro inductor -----	
L805	1-459-043	Horizontal Linearity -----	
L806	1-407-175	330 μ H, micro inductor -----	
L901	1-421-142	Choke Coil, filter -----	
DY	1-451-056-11	Deflection Yoke Ass'y -----	
<u>Transformers</u>			
T301	1-403-508	Transformer, first video i-f -----	
T302	1-403-508	Transformer, second video i-f -----	
T303	1-403-510	Transformer, third video i-f -----	
T351	1-403-534	Transformer, first sound i-f -----	
T352	1-403-534	Transformer, second sound i-f -----	
T353	1-403-535	Transformer, third sound i-f -----	
T354	1-403-536	Transformer, fourth sound i-f -----	
T355	1-403-536	Transformer, fifth sound i-f -----	
T356	1-403-537	Transformer, sixth sound i-f -----	
T357	1-403-538	Transformer, seventh sound i-f -----	
T402	1-403-364-11	Discriminator -----	
T403	1-403-364-21	Discriminator -----	
T501	1-403-354	SIF Input -----	
T701	1-435-008	Vertical Blocking Osc. -----	
T801	1-435-034	Horizontal Blocking Osc. -----	
T802	1-437-019	Horizontal Drive -----	
T803	1-453-021-12S	High Voltage Cage Block -----	
T805	1-459-043	Horizontal Linearity Coil -----	
T901	1-441-531	Power Trans -----	
	1-403-351	AGC Detector Block -----	
	1-403-353	Video Detector Block -----	
	1-403-366	AM SIF Detector Block -----	

<u>Ref. No.</u>	<u>Part No.</u>	<u>Description</u>	<u>Unit Price</u>
-----------------	-----------------	--------------------	-------------------

Capacitors

Capacitors are +100 -0 %, 50 WV and ceramic unless otherwise specified.

C301	1-101-552	3.5 pF ±0.2 pF 50 WV, ceramic -----	
C302	1-101-552	3.5 pF ±0.2 pF 50 WV, ceramic -----	
C304	1-101-004	0.01 µF -----	
C305	1-101-004	0.01 µF -----	
C306	1-101-004	0.01 µF -----	
C308	1-101-004	0.01 µF -----	
C309	1-101-004	0.01 µF -----	
C310	1-101-004	0.01 µF -----	
C311	1-101-004	0.01 µF -----	
C313	1-101-004	0.01 µF -----	
C314	1-121-413	100 µF +100 -10 % 6.3 WV, electrolytic-	
C315	1-101-004	0.01 µF -----	
C316	1-121-482	33 µF +100 -10 % 6.3 WV, electrolytic-	
C317	1-101-837	0.5 pF ±0.2 pF 50 WV, ceramic -----	
C319	1-101-004	0.01 µF -----	
C324	1-101-004	0.01 µF -----	
C325	1-121-471	10 µF +100 -10 % 16 WV, electrolytic -	
C326	1-121-712	200 µF ±20 % 10 WV, electrolytic -	
C327	1-121-338	47 µF +100 -10 % 16 WV, electrolytic -	
C328	1-101-004	0.01 µF -----	
C329	1-121-341	220 µF +100 -10 % 16 WV, electrolytic -	
C330	1-101-004	0.01 µF -----	
C331	1-101-004	0.01 µF -----	
C332			
C333	1-121-485	33 µF +100 -10 % 16 WV, electrolytic-	
C360	1-101-004	0.01 µF -----	
C361	1-101-004	0.01 µF -----	
C362	1-101-004	0.01 µF -----	
C364	1-101-004	0.01 µF -----	
C365	1-101-004	0.01 µF -----	
C366	1-101-004	0.01 µF -----	
C368	1-101-004	0.01 µF -----	
C369	1-101-004	0.01 µF -----	
C370	1-121-482	33 µF +100 -10 % 6.3 WV, electrolytic-	
C371	1-101-004	0.01 µF -----	
C373	1-101-004	0.01 µF -----	
C376	1-101-004	0.01 µF -----	
C377	1-101-004	0.01 µF -----	

6/16 (TV9-90UM)

(TV9-9-3)

<u>Ref. No.</u>	<u>Part No.</u>	<u>Description</u>	<u>Unit Price</u>
C378	1-101-004	0.01 μ F -----	
C379	1-101-004	0.01 μ F -----	
C381	1-101-004	0.01 μ F -----	
C382	1-101-004	0.01 μ F -----	
C383	1-101-004	0.01 μ F -----	
C385	1-101-004	0.01 μ F -----	
C386	1-101-004	0.01 μ F -----	
C387	1-121-482	33 μ F +100 -10 % 6.3 WV, electrolytic-	
C388	1-101-004	0.01 μ F -----	
C389	1-101-584	2 pF +0.2 pF 50 WV, ceramic -----	
C391	1-101-004	0.01 μ F -----	
C392	1-101-552	3.5 pF +0.2 pF 50 WV, ceramic -----	
C396	1-101-004	0.01 μ F -----	
C397	1-101-004	0.01 μ F -----	
C398	1-121-341	220 μ F +100 -10 % 16 WV, electrolytic -	
C399	1-121-716	10 μ F +20 % 50 WV, electrolytic -	
C401	1-101-004	0.01 μ F -----	
C402	1-101-004	0.01 μ F -----	
C403	1-101-004	0.01 μ F -----	
C404	1-101-004	0.01 μ F -----	
C407	1-101-002	0.002 μ F -----	
C408	1-101-058	0.005 μ F +20 % 50 WV, ceramic -----	
C409	1-121-729	10 μ F +100 -10 % 6.3 WV, electrolytic-	
C501	1-121-471	10 μ F +100 -10 % 16 WV, electrolytic -	
C502	1-101-583	60 pF +5 % 50 WV, ceramic -----	
C503	1-101-583	60 pF +5 % 50 WV, ceramic -----	
C504	1-121-338	47 μ F +100 -10 % 16 WV, electrolytic -	
C505	1-121-338	47 μ F +100 -10 % 16 WV, electrolytic -	
C506	1-105-701-12	0.001 μ F +10 % 100 WV, mylar -----	
C507	1-121-356	100 μ F +100 -10 % 16 WV, electrolytic -	
C508	1-113-124	0.2 μ F +20 % 150 WV, paper -----	
C509	1-121-246	4.7 μ F +100 -10 % 160 WV, electrolytic-	
C510	1-113-122	0.05 μ F +20 % 500 WV, paper -----	
C511	1-113-122	0.05 μ F +20 % 500 WV, paper -----	
C512	1-102-849	62 pF +5 % 50 WV, ceramic -----	
C513	1-102-888	150 pF +5 % 50 WV, ceramic -----	
C551	1-121-471	10 μ F +100 -10 % 16 WV, electrolytic -	
C552	1-121-732	470 μ F +100 -10 % 16 WV, electrolytic -	
C553	1-121-341	220 μ F +100 -10 % 16 WV, electrolytic -	
C554	1-121-485	33 μ F +100 -10 % 16 WV, electrolytic -	
C555	1-121-555	47 μ F +100 -10 % 16 WV, electrolytic -	

7/16 (TV9-90UM)

(TV9-9-3)

Ref. No.	Part No.	Description	Unit Price
C556	1-101-005	0.02 μ F -----	
C557	1-105-685-12	0.1 μ F ± 10 % 50 WV, mylar -----	
C558	1-101-005	0.02 μ F -----	
C601	1-127-021	0.3 μ F ± 20 % 10 WV, electrolytic (alox) -----	
C602	1-127-025	3 μ F ± 20 % 10 WV, electrolytic (alox) -----	
C603	1-121-464	4.7 μ F $\pm 100 -10$ % 25 WV, electrolytic -	
C604	1-121-338	47 μ F $\pm 100 -10$ % 16 WV, electrolytic -	
C605	1-105-713-12	0.01 μ F ± 10 % 100 WV, mylar -----	
C606	1-105-713-12	0.01 μ F ± 10 % 100 WV, mylar -----	
C607	1-105-709-12	0.0047 μ F ± 10 % 100 WV, mylar -----	
C608	1-105-715-12	0.015 μ F ± 10 % 100 WV, mylar -----	
C609	1-127-025	3 μ F ± 20 % 10 WV, electrolytic (alox) -----	
C610	1-105-721-12	0.047 μ F ± 10 % 100 WV, mylar -----	
C611	1-121-458	3.3 μ F $\pm 150 -10$ % 50 WV, electrolytic -	
C612	1-101-424	500 pF ± 20 % 250 WV, ceramic -----	
C613	1-105-711-12	0.0068 μ F ± 10 % 100 WV, mylar -----	
C701	1-127-232	4.7 μ F ± 20 % 25 WV, electrolytic (alox) -----	
C702	1-121-732	470 μ F $\pm 100 -10$ % 16 WV, electrolytic -	
C703	1-131-116	10 μ F ± 20 % 15 WV, tantalum -----	
C704	1-121-403	33 μ F $\pm 100 -10$ % 16 WV, electrolytic -	
C705	1-127-025	3.3 μ F ± 20 % 10 WV, electrolytic (alox) -----	
C706	1-121-414	100 μ F $\pm 100 -10$ % 10 WV, electrolytic -	
C707	1-105-727-12	0.15 μ F ± 10 % 100 WV, mylar -----	
C801	1-105-715-12	0.015 μ F ± 10 % 100 WV, mylar -----	
C802	1-105-711-12	0.0068 μ F ± 10 % 100 WV, mylar -----	
C804	1-101-007	0.05 μ F -----	
C805	1-129-163	0.022 μ F ± 5 % 50 WV, styrol -----	
C806	1-105-717-12	0.022 μ F ± 10 % 100 WV, mylar -----	
*C807,808	1-105-715-12	0.015 μ F ± 10 % 100 WV, mylar -----	
*C807,808	1-105-703-12	0.0015 μ F ± 10 % 100 WV, mylar -----	
*C807,808	1-105-705-12	0.0022 μ F ± 10 % 100 WV, mylar -----	
*C807,808	1-105-707-12	0.0033 μ F ± 10 % 100 WV, mylar -----	
*C807,808	1-105-709-12	0.0047 μ F ± 10 % 100 WV, mylar -----	
*C807,808	1-105-711-12	0.0068 μ F ± 10 % 100 WV, mylar -----	
*C807,808	1-105-713-12	0.01 μ F ± 10 % 100 WV, mylar -----	

* Mark to be selected.

8/16. (TV9-90UM)

(TV9-9-3)

<u>Ref. No.</u>	<u>Part No.</u>	<u>Description</u>	<u>Unit Price</u>
C809	1-105-725-12	0.1 μ F +10 %	100 WV, mylar -----
C810	1-101-821	0.002 μ F +100 -0 %	500 WV, ceramic -----
C814	1-101-845	0.001 μ F +100 -0 %	500 WV, ceramic -----
C812	1-105-466-12	0.0068 μ F +10 %	600 WV, mylar -----
*C811,813	1-105-461-12	0.001 μ F +10 %	600 WV, mylar -----
*C811,813	1-105-462-12	0.0015 μ F +10 %	600 WV, mylar -----
*C811,813	1-105-463-12	0.0022 μ F +10 %	600 WV, mylar -----
*C811,813	1-105-464-12	0.0033 μ F +10 %	600 WV, mylar -----
*C811,813	1-105-465-12	0.0047 μ F +10 %	600 WV, mylar -----
*C811,813	1-105-466-12	0.0068 μ F +10 %	600 WV, mylar -----
C815	1-101-845	0.001 μ F +100 -0 %	500 WV, ceramic -----
C816	1-129-496	1.8 μ F +10 %	100 WV, styrol -----
C817	1-129-497	1 μ F +10 %	100 WV, styrol -----
C818	1-101-845	0.001 μ F +100 -0 %	500 WV, ceramic -----
C819	1-121-703	100 μ F +100 -10 %	50 WV, electrolytic -
C820	1-121-703	100 μ F +100 -10 %	50 WV, electrolytic -
C821	1-105-755-12	0.015 μ F +10 %	200 WV, mylar -----
C822	1-113-122	0.05 μ F +20 %	500 WV, paper -----
C823	1-105-749-12	0.0047 μ F +10 %	200 WV, mylar -----
C824	1-101-845	0.001 μ F +100 -0 %	500 WV, ceramic -----
C828	1-105-465-12	0.0047 μ F +10 %	600 WV, mylar -----
C901	1-109-015	2000 pF +10 %	500 WV, mica -----
C902	1-109-015	2000 pF +10 %	500 WV, mica -----
C903	1-121-023	4000 μ F	15 WV, electrolytic -
C904	1-119-101	100 μ F +30 -10 %	12 WV, electrolytic -
C905	1-121-023	4000 μ F	15 WV, electrolytic -

* Mark to be selected.

9/16 (TV9-90UM)

(TV9-9-3)

<u>Ref. No.</u>	<u>Part No.</u>	<u>Description</u>	<u>Unit Price</u>
-----------------	-----------------	--------------------	-------------------

Resistors

Resistors are $\pm 5\%$, ERD14V, and carbon unless otherwise specified.

R151	1-246-653	150 Ω ERD14T, carbon	-----
R301	1-246-637	33 Ω ERD14T, carbon	-----
R302	1-248-649	100 Ω	-----
R303	1-248-659	270 Ω	-----
*R304	1-204-154	510 Ω RD1/16L, carbon	-----
*R304	1-203-182	1 k Ω RD1/16L, carbon	-----
*R304	1-204-195	2 k Ω RD1/16L, carbon	-----
R305	1-246-666	510 Ω ERD14T, carbon	-----
R306	1-246-649	100 Ω ERD14T, carbon	-----
R307	1-248-659	270 Ω ERD14T, carbon	-----
*R308	1-203-469	6.2 k Ω RD1/16L, carbon	-----
*R308	1-203-189	8.2 k Ω RD1/16L, carbon	-----
*R308	1-203-190	10 k Ω RD1/16L, carbon	-----
*R308	1-203-699	20 k Ω RD1/16L, carbon	-----
R309	1-248-653	150 Ω	-----
R310	1-248-691	5.6 k Ω	-----
R311	1-248-675	1.2 k Ω	-----
R312	1-248-653	150 Ω	-----
*R313	1-203-469	6.2 k Ω RD1/16L, carbon	-----
*R313	1-203-189	8.2 k Ω RD1/16L, carbon	-----
*R313	1-203-190	10 k Ω RD1/16L, carbon	-----
*R313	1-203-699	20 k Ω RD1/16L, carbon	-----
R314	1-248-646	75 Ω	-----
R315	1-248-687	3.9 k Ω	-----
R316	1-248-696	9.1 k Ω	-----
*R317	1-248-688	4.3 k Ω	-----
*R317	1-248-689	4.7 k Ω	-----
*R317	1-248-690	5.1 k Ω	-----
R318	1-248-676	1.3 k Ω	-----
R319	1-248-655	180 Ω	-----
R320	1-248-657	220 Ω	-----
R321	1-248-667	560 Ω	-----
R322	1-248-641	47 Ω	-----
*R323	1-246-703	18 k Ω ERD14T, carbon	-----
*R323	1-246-704	20 k Ω ERD14T, carbon	-----
*R323	1-246-705	22 k Ω ERD14T, carbon	-----

* Mark to be selected.

10/16 (TV9-90UM)

(TV9-9-3)

<u>Ref.</u> <u>No.</u>	<u>Part No.</u>	<u>Description</u>	<u>Unit</u> <u>Price</u>
R324	1-246-681	2.2 kΩ ERD14T, carbon	-----
R351	1-246-649	100 Ω ERD14T, carbon	-----
R352	1-248-673	1 kΩ	-----
R353	1-246-660	300 Ω ERD14T, carbon	-----
*R354	1-203-469	6.2 kΩ RD1/16L, carbon	-----
*R354	1-203-189	8.2 kΩ RD1/16L, carbon	-----
*R354	1-203-190	10 kΩ RD1/16L, carbon	-----
*R354	1-203-699	20 kΩ RD1/16L, carbon	-----
R355	1-248-660	300 Ω	-----
R356	1-248-695	8.2 kΩ	-----
R357	1-248-684	3 kΩ	-----
R358	1-248-660	300 Ω	-----
*R359	1-204-195	2 kΩ RD1/16L, carbon	-----
*R359	1-203-451	3 kΩ RD1/16L, carbon	-----
*R359	1-204-345	5.1 kΩ RD1/16L, carbon	-----
R360	1-248-660	300 Ω	-----
R361	1-248-696	9.1 kΩ	-----
R362	1-248-675	1.2 kΩ	-----
R363	1-248-651	120 Ω	-----
*R364	1-203-469	6.2 kΩ RD1/16L, carbon	-----
*R364	1-203-189	8.2 kΩ RD1/16L, carbon	-----
*R364	1-203-190	10 kΩ RD1/16L, carbon	-----
*R364	1-203-699	20 kΩ RD1/16L, carbon	-----
R365	1-248-653	150 Ω	-----
R366	1-246-673	1 kΩ ERD14T, carbon	-----
R367	1-248-649	100 Ω	-----
R368	1-248-660	300 Ω	-----
*R369	1-204-154	510 Ω RD1/16L, carbon	-----
*R369	1-203-182	1 kΩ RD1/16L, carbon	-----
*R369	1-204-195	2 kΩ RD1/16L, carbon	-----
R370	1-246-660	300 Ω ERD14T, carbon	-----
R371	1-246-695	8.2 kΩ ERD14T, carbon	-----
R372	1-248-684	3 kΩ	-----
R373	1-248-660	300 Ω	-----
*R374	1-203-856	150 Ω RD1/16L, carbon	-----
*R374	1-204-534	300 Ω RD1/16L, carbon	-----
*R374	1-204-154	510 Ω RD1/16L, carbon	-----
R375	1-248-660	300 Ω	-----
R376	1-248-696	9.1 kΩ	-----
R377	1-248-675	1.2 kΩ	-----
R378	1-248-651	120 Ω	-----

* Mark to be selected.

11/16 (TV9-90UM)

(TV9-9-3)

<u>Ref. No.</u>	<u>Part No.</u>	<u>Description</u>	<u>Unit Price</u>
*R379	1-204-195	2 kΩ RD1/16L, carbon	-----
*R379	1-203-451	3 kΩ RD1/16L, carbon	-----
*R379	1-204-345	5.1 kΩ RD1/16L, carbon	-----
R380	1-248-653	150 Ω	-----
*R381	1-204-195	2 kΩ RD1/16L, carbon	-----
*R381	1-203-451	3 kΩ RD1/16L, carbon	-----
*R381	1-204-345	5.1 kΩ RD1/16L, carbon	-----
R382	1-246-641	47 Ω ERD14T, carbon	-----
R383	1-246-704	20 kΩ ERD14T, carbon	-----
R384	1-248-703	18 kΩ	-----
R385	1-248-699	12 kΩ	-----
R401	1-248-656	200 Ω	-----
R402	1-246-688	4.3 kΩ ERD14T, carbon	-----
R404	1-202-018	3.9 kΩ RC1/8, composition	-----
R405	1-248-661	330 Ω	-----
R501	1-248-714	51 kΩ	-----
R502	1-248-710	36 kΩ	-----
R503	1-248-663	390 Ω	-----
R504	1-248-663	390 Ω	-----
R505	1-248-673	1 kΩ	-----
R507	1-248-708	30 kΩ	-----
R508	1-248-693	6.8 kΩ	-----
R509	-	-	-----
R510	1-248-643	56 Ω	-----
R511	1-248-673	1 kΩ	-----
R512	1-244-891	5.6 kΩ RD12T, carbon	-----
R513	1-244-921	100 kΩ RD12T, carbon	-----
R514	1-248-697	10 kΩ	-----
R515	1-248-732	300 kΩ	-----
R551	1-246-715	56 kΩ ERD14T, carbon	-----
R552	1-246-673	1 kΩ ERD14T, carbon	-----
R553	1-248-697	10 kΩ	-----
R554	1-248-697	10 kΩ	-----
R555	1-248-679	1.8 kΩ	-----
R556	1-248-612	3 Ω	-----
R557	1-248-693	6.8 kΩ	-----
R558	1-248-675	1.2 kΩ	-----
R559	1-248-641	47 Ω	-----
R560	1-248-655	180 Ω	-----
R561	1-248-656	200 Ω	-----

* Mark to be selected.

12/16 (TV9-90UM)

(TV9-9-3)

<u>Ref. No.</u>	<u>Part No.</u>	<u>Description</u>	<u>Unit Price</u>
R562	1-248-675	1.2 kΩ	
R563	1-248-612	3 Ω	
R564	1-248-618	5.1 Ω	
R565	1-246-631	18 Ω ERD14T, carbon	
R566	1-246-655	180 Ω ERD14T, carbon	
R601	1-248-642	51 Ω	
R602	1-248-661	330 Ω	
R603	1-248-697	10 kΩ	
R604	1-248-737	470 kΩ	
R605	1-248-684	3 kΩ	
R606	1-248-697	10 kΩ	
R607	1-248-701	15 kΩ	
R608	1-248-712	43 kΩ	
R609	1-248-656	200 Ω	
R610	1-248-682	2.4 kΩ	
R611	1-248-697	10 kΩ	
R612	1-248-686	3.6 kΩ	
R613	1-211-063	2 kΩ RD1P, carbon	
R614	1-248-680	2 kΩ	
R615	1-248-666	510 Ω	
R616	1-248-701	15 kΩ	
R617	1-248-680	2 kΩ	
R618	1-248-704	20 kΩ	
R619	1-248-662	360 Ω	
R620	1-248-625	10 Ω	
R621	1-206-057	150 Ω 2 WV, metal oxide	
R701	1-248-660	300 Ω	
R702	1-248-688	4.3 kΩ	
R703	1-248-677	1.5 kΩ	
R704	1-248-625	10 Ω	
R705	1-248-688	4.3 kΩ	
R706	1-248-690	5.1 kΩ	
R707	1-246-703	18 kΩ ERD14T, carbon	
R708	1-248-680	2 kΩ	
R709	1-248-680	2 kΩ	
R710	1-248-688	4.3 kΩ	
*R711	1-248-671	820 Ω	
*R711	1-248-673	1 kΩ	
*R711	1-248-675	1.2 kΩ	
*R711	1-248-677	1.5 kΩ	

* Mark to be selected.

13/16 (TV9-90UM)

(TV9-9-3)

<u>Ref. No.</u>	<u>Part No.</u>	<u>Description</u>	<u>Unit Price</u>
*R711	1-248-679	1.8 kΩ -----	
*R711	1-248-680	2 kΩ -----	
*R711	1-248-681	2.2 kΩ -----	
*R711	1-248-682	2.4 kΩ -----	
R712	1-248-665	470 Ω -----	
R713	1-207-073	3 Ω RW1/2RL, wire wound -----	
R714	1-248-661	330 Ω -----	
R715	-	-	
R716	1-248-697	10 kΩ -----	
R801	1-248-688	4.3 kΩ -----	
R802	1-248-673	1 kΩ -----	
R803	1-248-666	510 Ω -----	
R804	1-248-666	510 Ω -----	
R805	1-248-660	300 Ω -----	
R806	1-207-092	8.2 Ω RW1/2RL, wire wound -----	
R807	1-248-691	5.6 kΩ -----	
R808	1-248-658	240 Ω -----	
R809	1-248-673	1 kΩ -----	
R810	1-248-621	100 kΩ RC1/2, composition -----	
R811	1-202-621	100 kΩ RC1/2, composition -----	
R812	1-246-704	20 kΩ ERD14T, carbon -----	
R813	1-207-094	11 Ω RW1/2RL, wire wound -----	
R901	1-207-054	3.9 Ω RW3L, wire wound -----	
VR301	1-221-326	500 Ω-B, adjustable (AGC) -----	
VR501	1-221-709	1 kΩ-E, variable (contrast) -----	
VR502	1-221-429	250 kΩ-B, variable (brightness) -----	
VR551	1-222-271	5 kΩ-D, variable (sound) -----	
VR601	1-221-297	10 kΩ-B, variable (H. hold) -----	
VR602	1-221-390	3 kΩ-B, variable (H. freq.) 819 lines -----	
VR603	1-221-390	3 kΩ-B, variable (H. freq.) 625 lines -----	
VR701	1-221-403	2 kΩ-B, variable (V. hold) -----	
VR702	1-221-389	5 kΩ-B, variable (V. hieg) -----	
VR703	1-221-390	3 kΩ-B, variable (V. lin) -----	

* Mark to be selected.

<u>Ref. No.</u>	<u>Part No.</u>	<u>Description</u>	<u>Unit Price</u>
		<u>Miscellaneous</u>	
	1-231-089-11	AM SIF Filter Block -----	
	1-509-344	Socket, voltage changing -----	
	1-506-108	Terminal Pin, SV -----	
	1-508-044-21	Plug, 9 pin -----	
	1-507-134-21	Jack, 9 pin -----	
	1-509-091-12	Connector, 3 pin -----	
	1-526-083-42	Socket, picture tube -----	
	1-514-593	Switch, 2-pushbutton -----	
	1-536-149	Terminal Strips, 2-L -----	
	1-536-171	Terminal Strips, L-7-L -----	
CRT	8-731-209-99	Picture Tube (230DB4) -----	
DFM-1	1-417-027	U.V. Tuner Separator with High Pass Filter --	
	1-502-169	Speaker -----	
	1-501-092-12S	Antenna Ass'y, telescopic -----	
	1-507-174-22	Jack, 2 P earphone -----	
J901	1-508-082-23	Terminal, 4 pole -----	
Se901	1-531-027	Selenium Rectifier -----	
S902	1-513-216-14	Switch, charging -----	
F901	1-532-201-12	Fuse, thermal -----	
F902	1-532-204	Fuse, 2 A -----	
	1-506-198	DC2p Plug with Fuse Holder -----	
	1-534-379-51	Cable, IF output -----	
	1-534-587-11	Cord, AC power -----	
	1-536-144	Terminal Strips, L-1 -----	
	1-536-192	Terminal Strips, 2-L-2 -----	
P901	1-536-249	Terminal, 4 pole power -----	

<u>Part No.</u>	<u>Description</u>	<u>Unit Price</u>
IV. <u>CARTONS & ACCESSORIES</u>		
4-012-817	Packing Carton -----	
4-012-816	Master Carton (2 sets) -----	
4-012-818	Cushion, right -----	
4-012-819	Cushion, left -----	
4-011-018	Polyethylene Bag -----	
X-40128-06	Card Ass'y -----	
X-44900-03	Polishing Cloth in Polyethylene Bag -----	
4-495-234-11	Instruction Manual -----	
1-504-034-22	Earphone (ME-20A) -----	
4-004-143	Serial Number Label -----	
3-701-161	Polyethylene Bag, accessories -----	

EXTERNAL VIEW

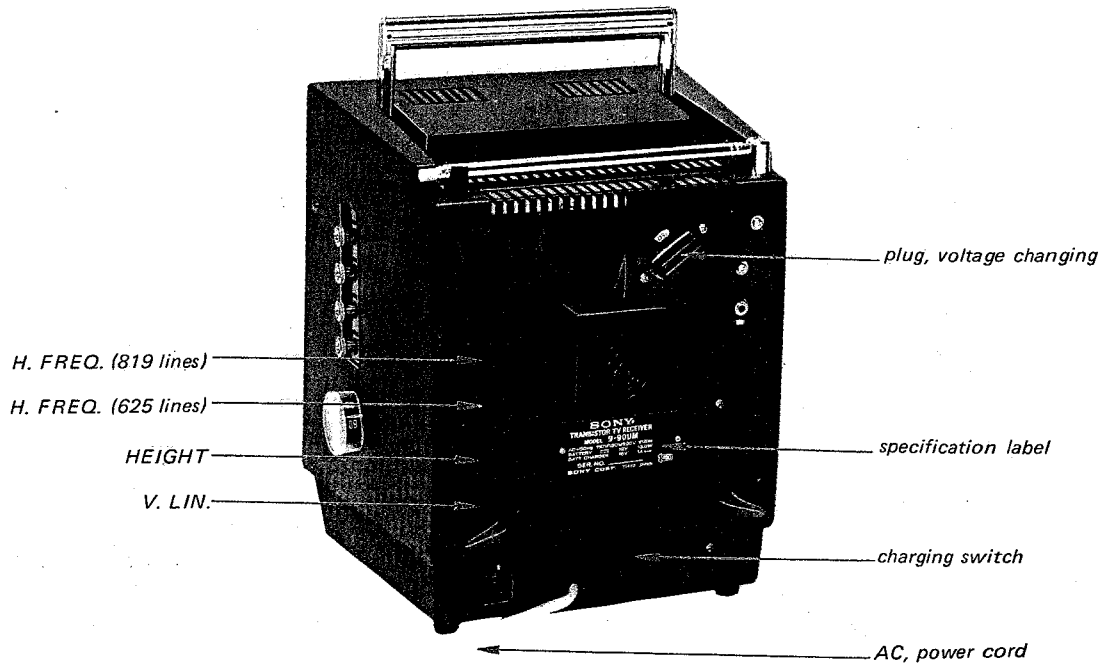
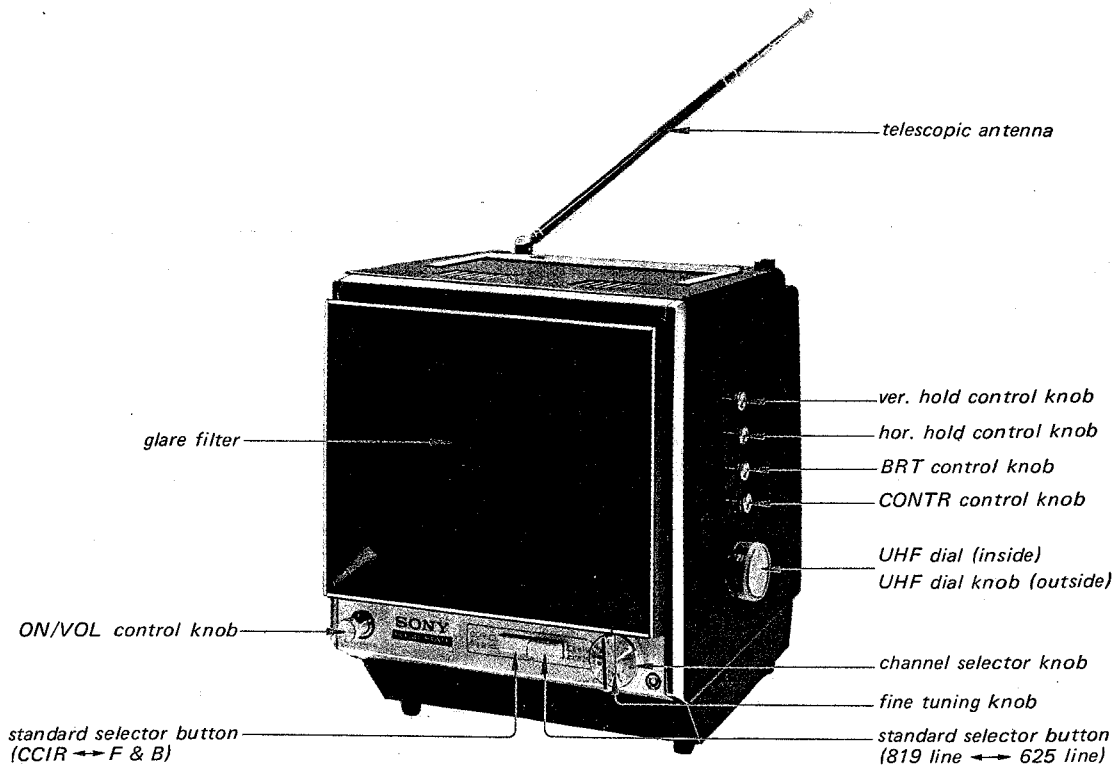

TV9-90UM

MAJOR PARTS LOCATION

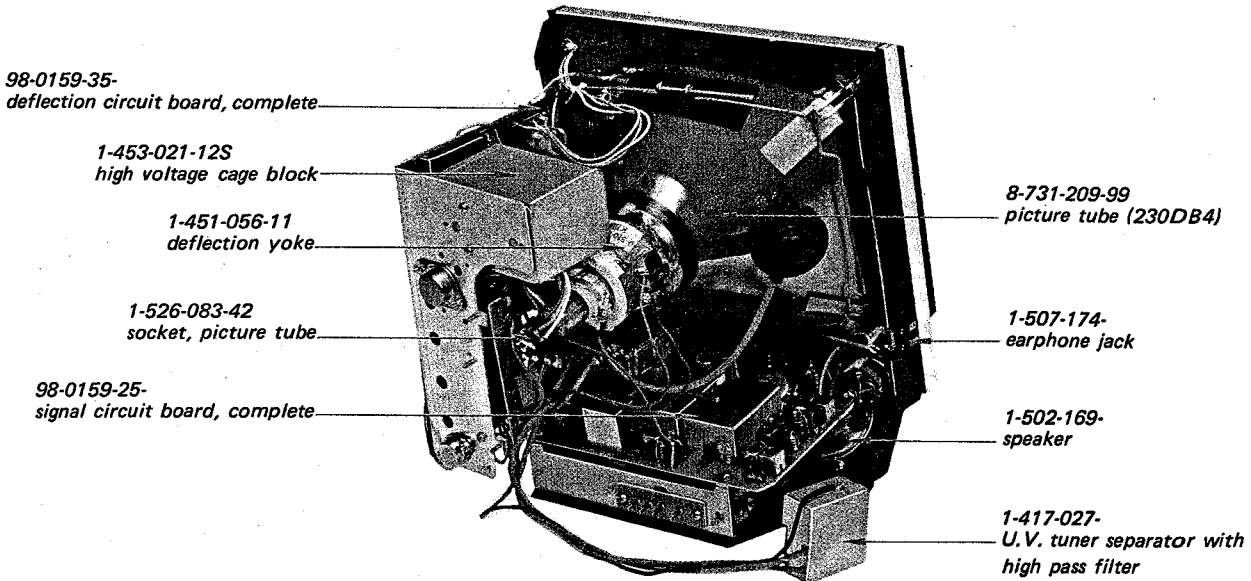
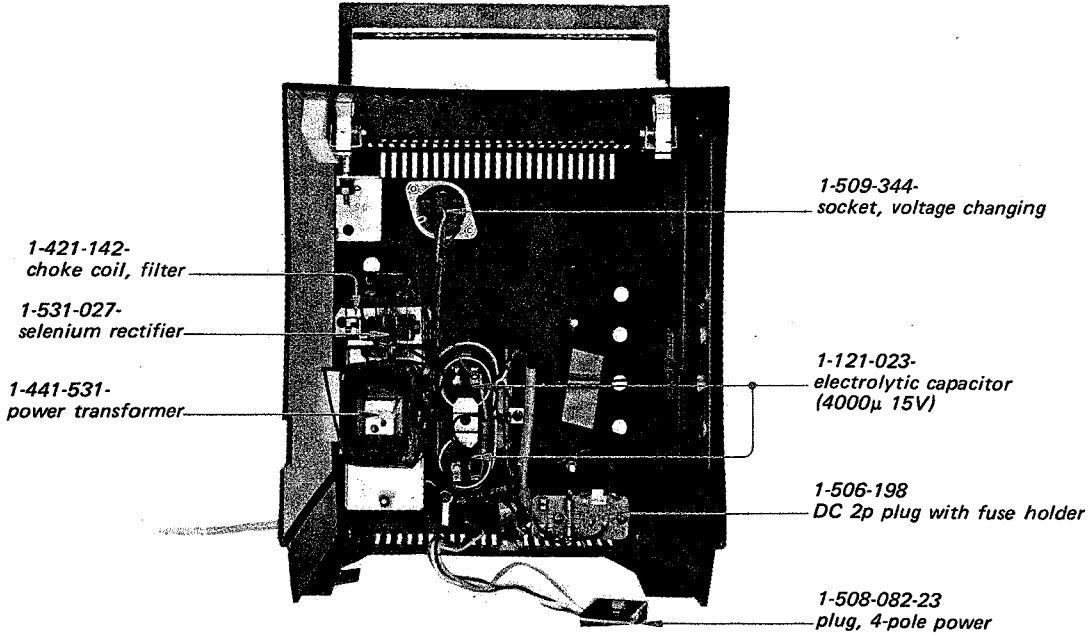

DISASSEMBLY

Rear Cabinet Removal

1. Pull off the four control knobs and UHF dial and UHF dial knob (①, ② in Fig. 1).
2. Remove the two screws (③, ④ in Fig. 1).
3. Remove the three screws (①, ②, ③ in Fig. 2).
4. Remove the two screws (②, ③ in Fig. 3).

Glare Filter Removal

1. Remove the two screws (① in Fig. 3).

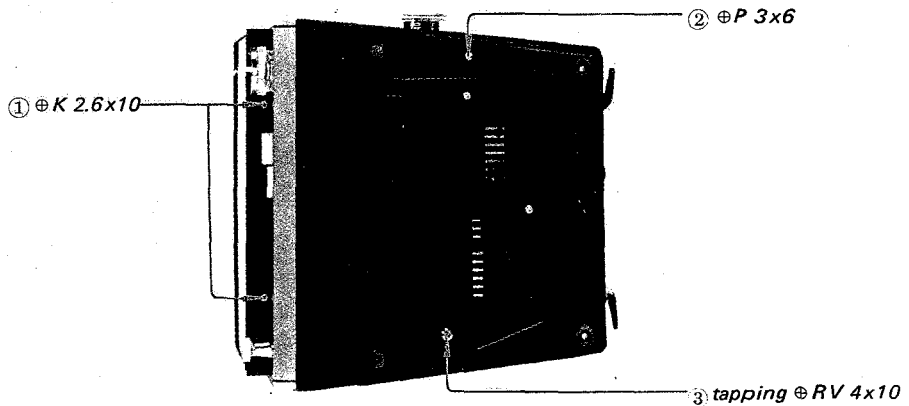
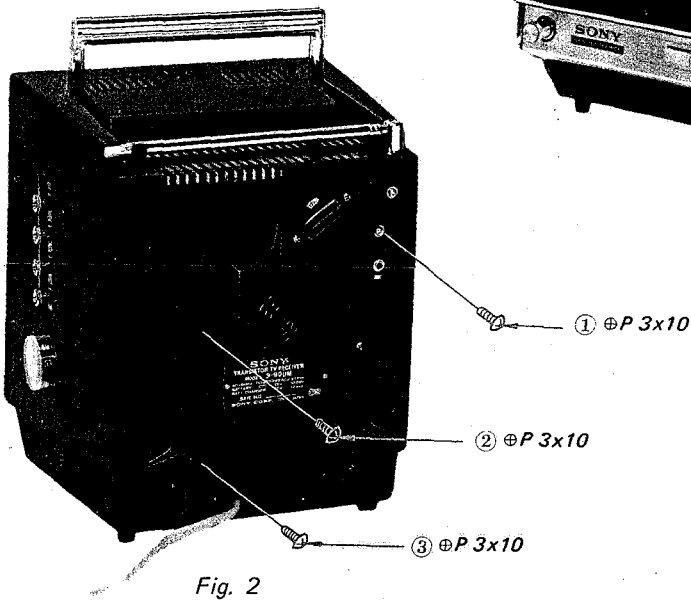
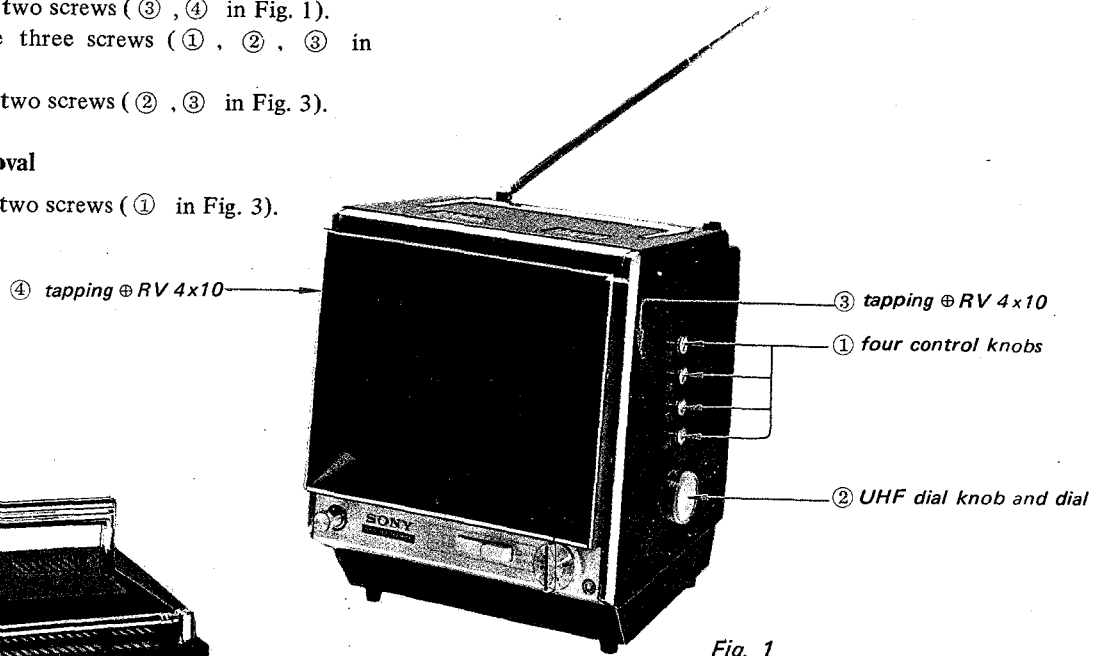

Deflection Circuit Board Removal

1. Remove the two screws (① , ② in Fig. 4).
2. Unsolder the braided wire (③ in Fig. 4).
3. Pull off the anode cap and picture tube socket (① , ② in Fig. 5).
4. Disconnect the 3-pole connector and 9-pole connector (③ , ④ in Fig. 5).
5. Unsolder the three black leads (⑥ in Fig. 5).
6. Unsolder a brown lead (⑤ in Fig. 5).
7. Unsolder the two shielded cables (⑦ , ⑩ in Fig. 6).
8. Unsolder the eight leads (① , ② , ③ , ④ , ⑤ , ⑦ , ⑧ , ⑨ , in Fig. 6).

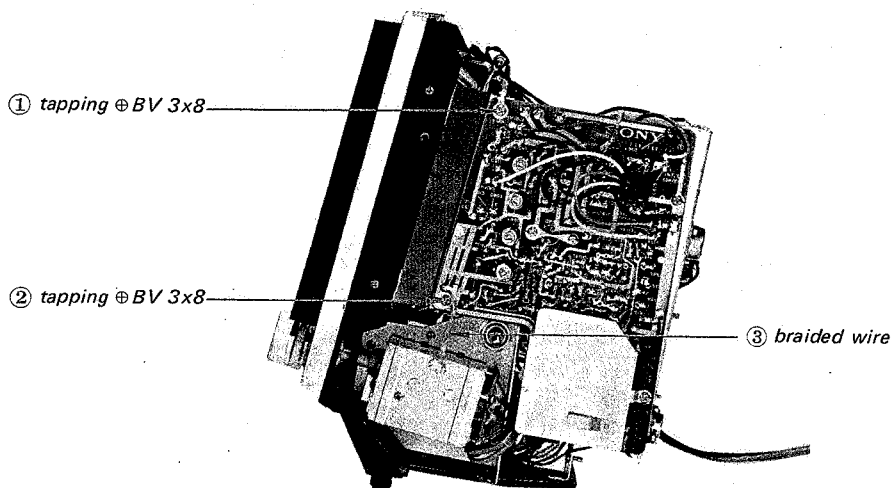

Fig. 4

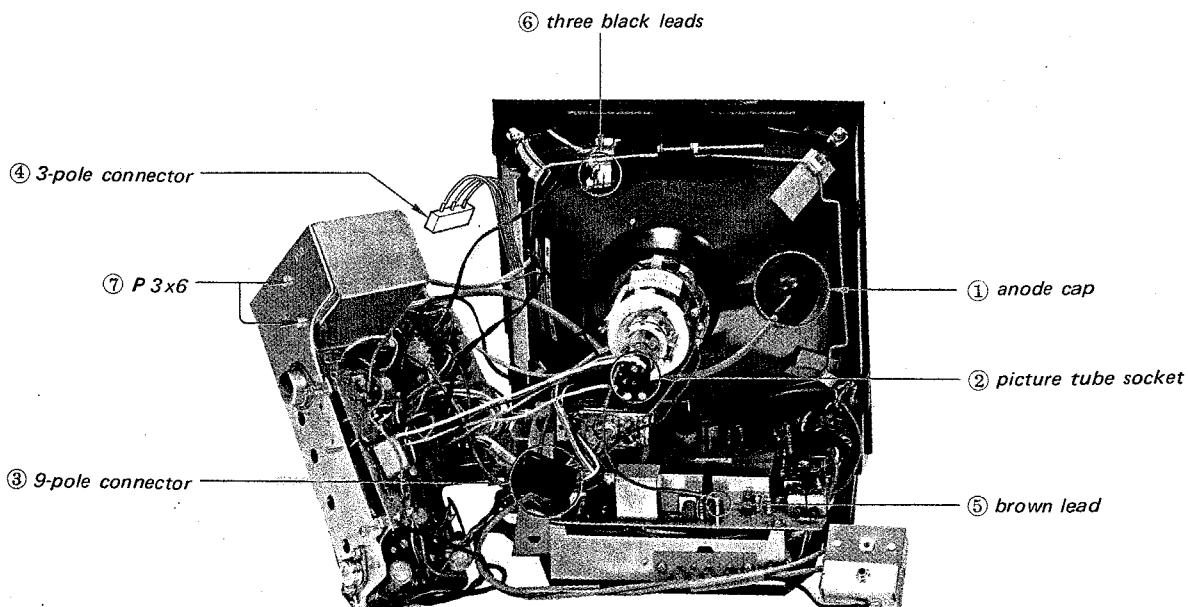

Fig. 5

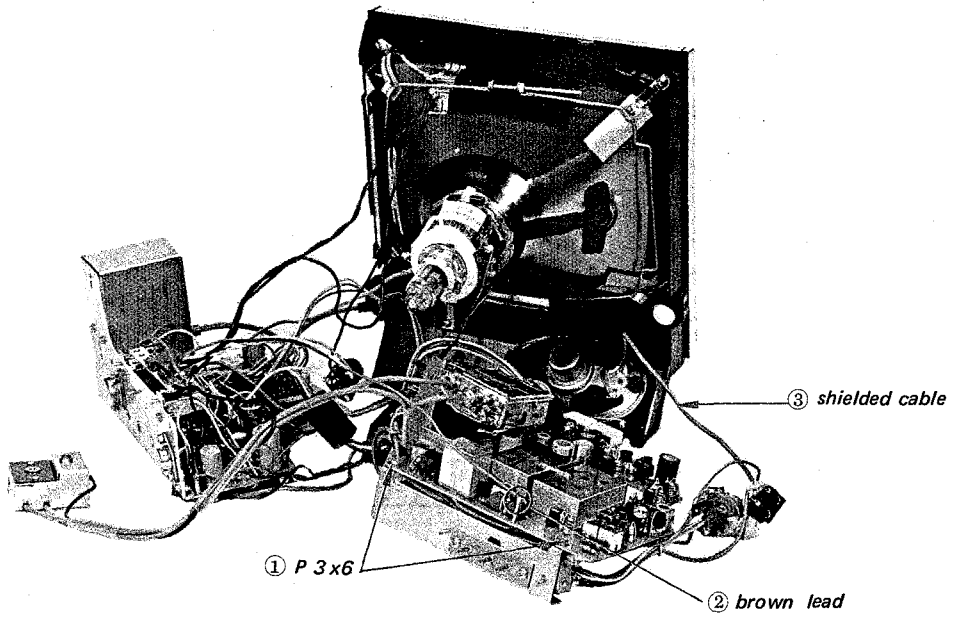
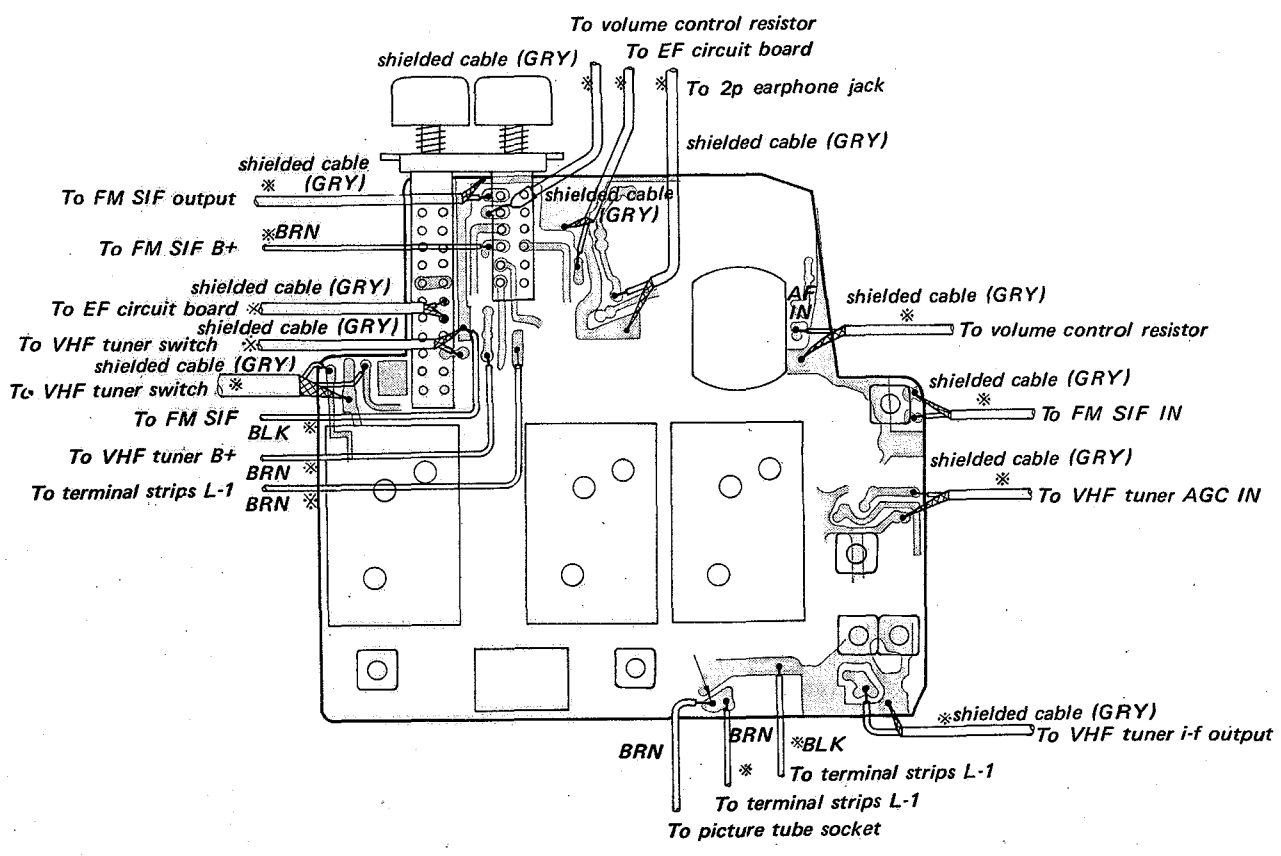

Fig. 9



*..... Soldered on the conductor side

Fig. 10

FM SIF Block Removal

1. Take out BC block.
2. Remove the two screws (① in Fig. 11).
3. Unsolder the two leads and the two shielded cables in Fig. 12.

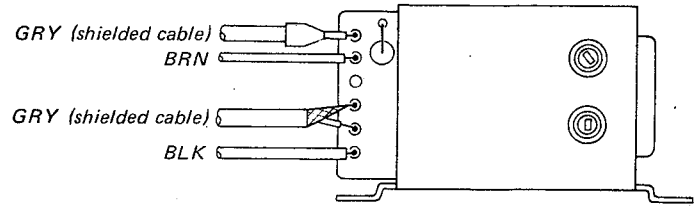

Fig. 12

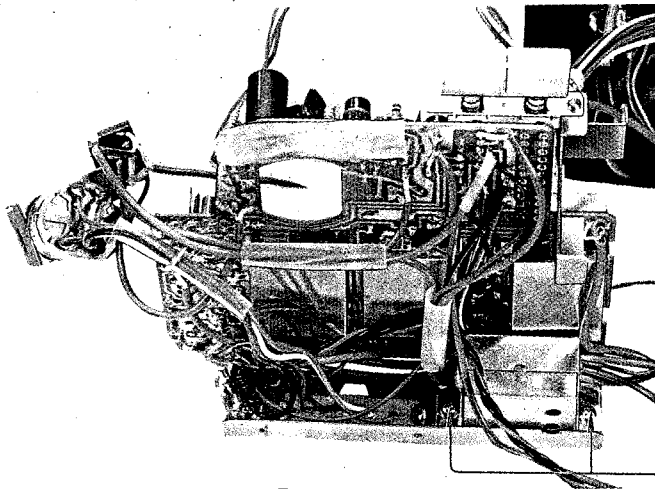

Fig. 11

① tapping \oplus BV 3x8

UHF Tuner Removal

1. Take out the BC block.
2. Remove a nut (② in Fig. 13).
3. Disconnect a phono plug in Fig. 14.
4. Unsolder a coaxial cable, and an orange lead (① , ② in Fig. 14).

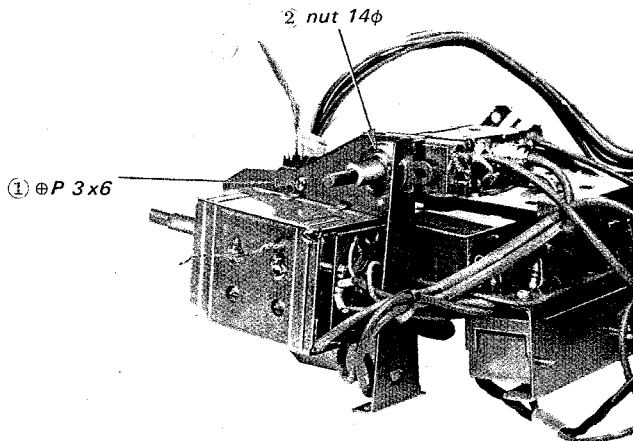

Fig. 13

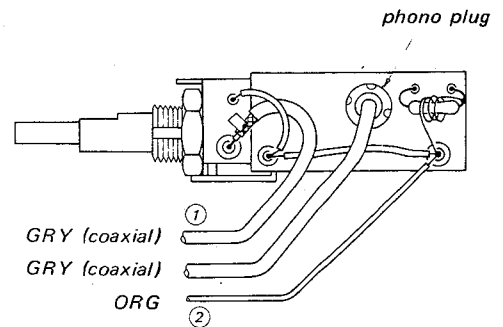

Fig. 14

VHF Tuner Removal

1. Take out the BC block.
2. Remove a screw (① in Fig. 13).
3. Unsolder a coaxial cable (② in Fig. 15).
4. Remove the three screws (① in Fig. 15).
5. Unsolder the three coaxial cables (① in Fig. 16).
6. Unsolder a brown lead (② in Fig. 16).
7. Remove the three screws (③ in Fig. 16).

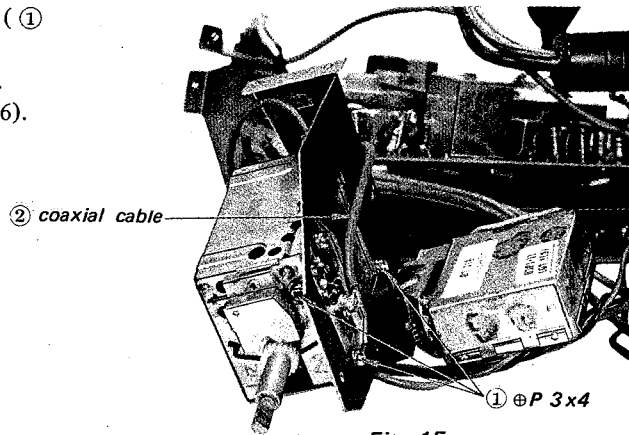

Fig. 15

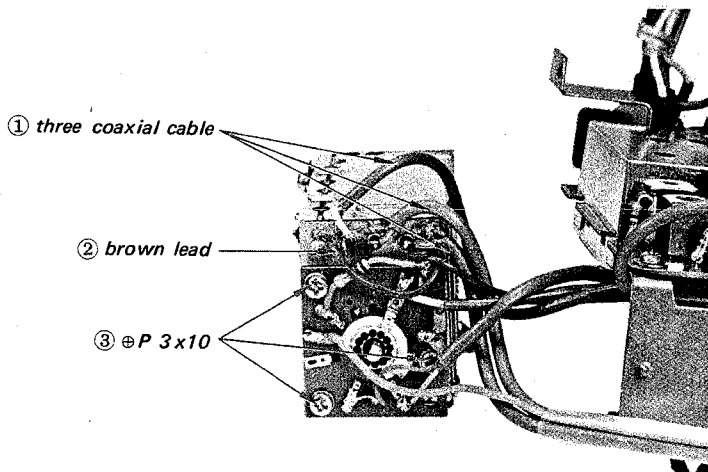

Fig. 16

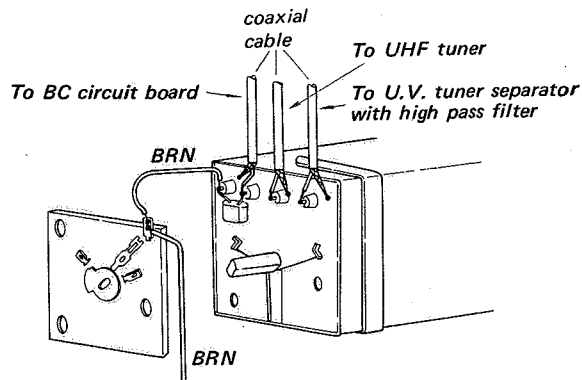

Fig. 17

Picture Tube Removal

1. Remove the four screws (① , ② in Fig. 18).

Speaker Removal

1. Remove a screw (③ in Fig. 18).

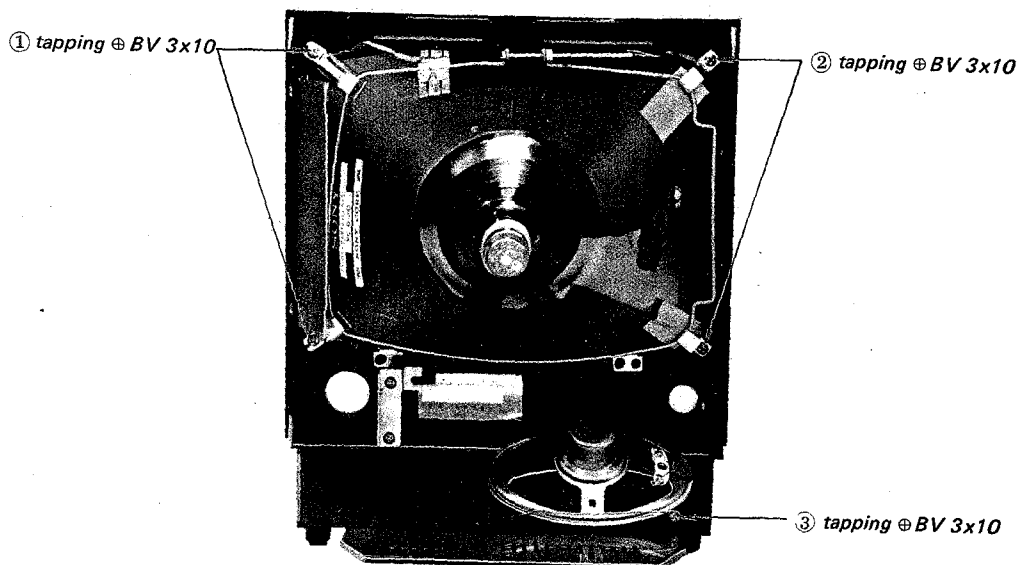

Fig. 18

ADJUSTMENTS PROCEDURE

VIF Adjustments

Pre-alignment Procedures

1. Set the channel selector to a highest inactive channel in the area.
2. Remove the coaxial cable from the RF input terminal of tuner.
3. Check the 12V line.
4. Connect a VOM to AGC input terminal of tuner.
5. Set the push switch button to CCIR (625 lines) position.
6. Set a resistor R323 (18k - 20k ohms) for a reading of 1.25 - 1.35 volts. (See Fig. 19).
7. Disconnect the VOM.

VIF Response Curve Alignment Procedures

1. Connect a signal generator to the test point of tuner through a 0.01 μ F capacitor (① in Fig. 19).
2. Connect a scope to the VIF output terminal (VIDEO OUT) through a noise filter consisting of a 10k-ohm resistor and 200pF capacitor (② in Fig. 19).
3. Set the signal generator to 40.4 MHz with 1 kHz AM modulation.
4. Adjust a coil L301 for obtaining minimum modulated waveform on the scope.
5. Reset the signal generator to 33.4 MHz with 1 kHz AM modulation.

6. Adjust a coil L302 for obtaining minimum modulated waveform on the scope.
7. Make the adjustments specified in the following Table 1.
8. Disconnect the signal generator from the test point.
9. Connect the sweep/marker generator to the test point (C in Fig. 19).
10. Connect a rheostat (10k-ohm) to the point indicated with D in Fig. 19.
11. Connect a VOM across a resistor R303 (E in Fig. 19).
12. Adjust the rheostat for a reading of approx. 1.5 volts on the VOM.
13. Disconnect the VOM.
14. Adjust the output level of sweep generator to obtain a 1.5 Vp-p VIF response curve on the scope.
15. Readjust T301, T302 and T303 to obtain the VIF response curve as shown in Fig. 20.
16. Adjust L207 in the tuner when satisfactory VIF response curve is not obtained by foregoing procedures (F in Fig. 19).
17. Repeat steps from 1 to 15.

TABLE 1 VIF ADJUSTMENTS

Frequency (MHz) with 1 kHz AM modulation	Adjust	Remarks
36.8	T301	Adjust T301 for obtaining maximum modulated waveform on the scope.
36.8	T302	Same as above.
35.4	T303	Same as above.

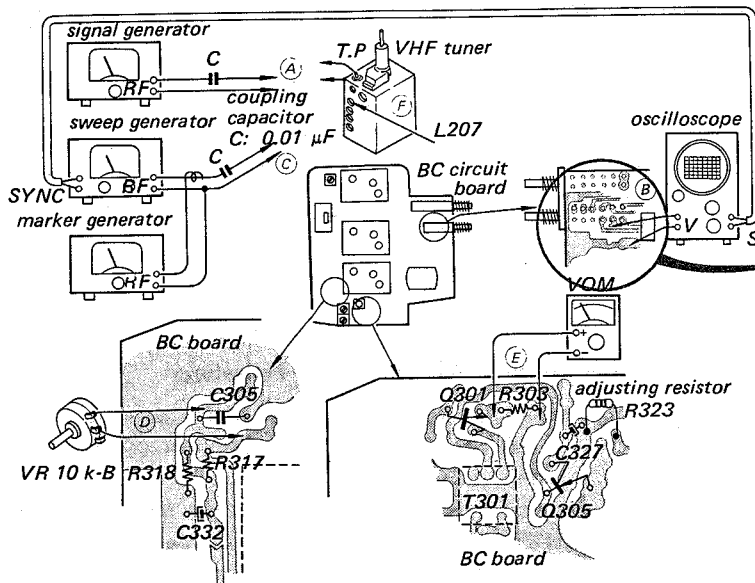

Fig. 19

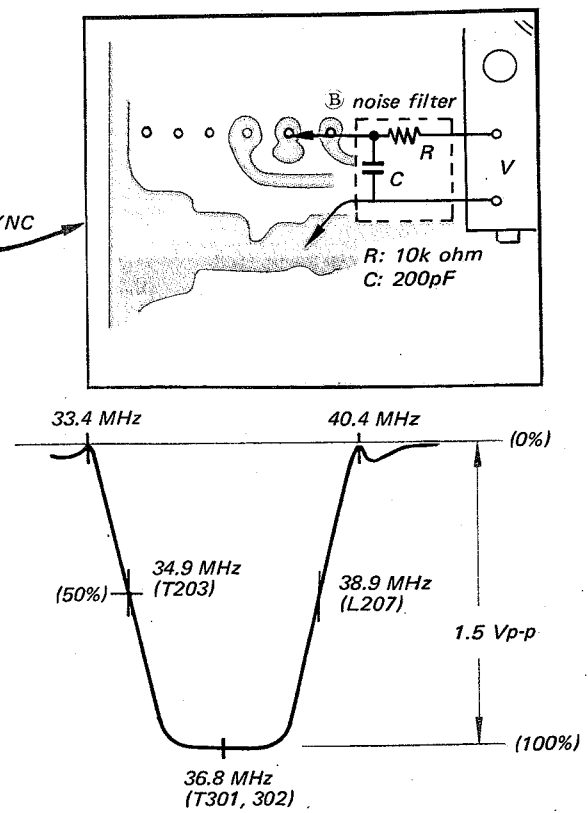

Fig. 20

SIF Adjustments

Unsolder the VIF INPUT coaxial cable first. Remove the SIF and VIF shield covers. Equipment setup is shown in Fig. 21.

Items	Equipment Connection	Adjust	Remarks
T501 T402 T403	Signal Generator (A) Signal: 5.5 MHz (400 Hz 30% AM) VOM (B) Range: 0.5V or 1.5V dc Scope (C)	T501 T402 (pink core) T403 (blue core)	Adjust for maximum indication on the VOM. Adjust for minimum modulated waveform.
Confirmation of S curve	Sweep/marker generator. . (A) Freq.: 5.5 MHz Scope (C)	T501 T402 (pink core) T403 (blue core)	Turn up sweep generator output to produce an S curve. If the S curve is not symmetrical as illustrated in Fig. 22, adjust T501, T402 and T403 for best result.

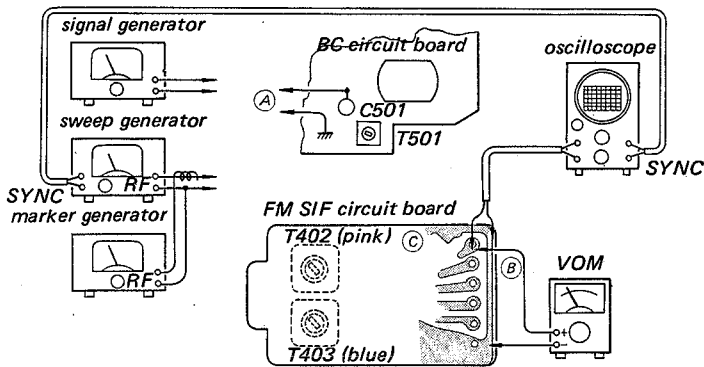

Fig. 21

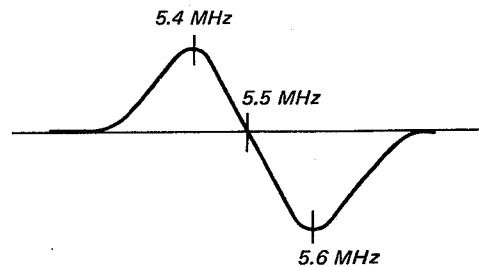

Fig. 22

AM-SIF Adjustments

46.5 MHz AM-SIF response curve adjustments

1. Set the push switch button to F & B (819 lines).
2. Unsolder the tuner output lead from signal circuit board (BC).
3. Connect a dummy resistor (5k-ohm) across the scope input terminal through a noise filter consisting of a 10k-ohm resistor and a 200pF capacitor as shown in Fig. 23.
4. Connect a sweep/marker generator to the AM-SIF input to the signal circuit board (BC) through a 0.01μF capacitor as shown in Fig. 23.
5. Make the adjustments specified in the following table.

Equipment	Connection	Frequency	Adjust	Indication
Signal generator	AM-SIF input (A in Fig. 23)	46.5 MHz (with 1 kHz AM)	T351 T352 T353	For maximum modulated waveform on the scope.
Scope	AM-SIF output (B in Fig. 23)			
Sweep generator Marker generator	AM-SIF input (C in Fig. 23)			Set the sweep generator switch on. Confirm that the AM-SIF (46.5 MHz) response curve will appear on the scope (See Fig. 24).
Scope	AM-SIF output (B in Fig. 23).			

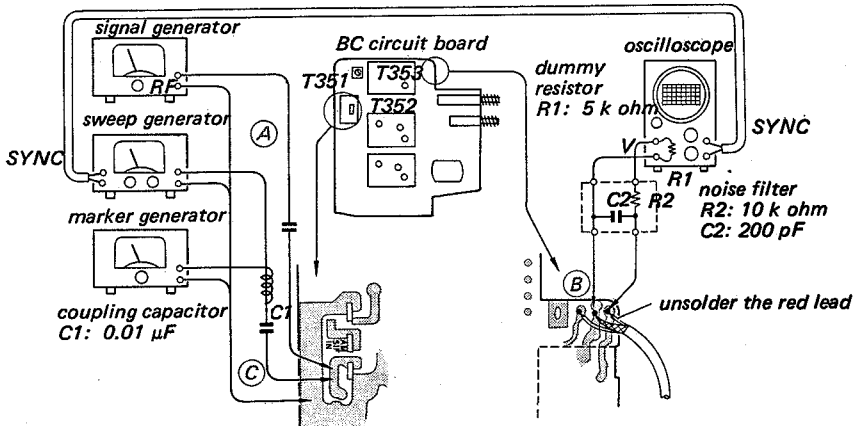

Fig. 23

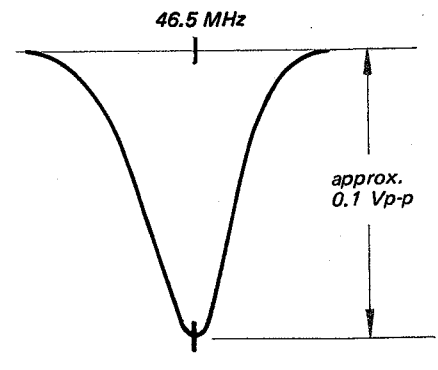

Fig. 24

27.5 MHz & 32.6 MHz AM-SIF response curve adjustments

1. Set the push switch button to F & B (625 lines).
2. Unsolder the tuner output lead from signal circuit board (BC).
3. Connect a dummy resistor (5k-ohm) across the scope input terminal through a noise filter consisting of a 10k-ohm resistor and a 200pF capacitor as shown in Fig. 25.
4. Connect a sweep/marker generator to the AM-SIF input to the signal circuit board (BC) through a 0.01μF capacitor as shown in Fig. 25.
5. Adjust T354 and T355 to obtain the maximum AM-SIF response curve on the scope.
6. Make the adjustments specified in the following table.

Marker generator Frequency (MHz)	Adjust	Correct marker position on the response curve	Indication
27.5	T356	A (peak)	Adjust T356 and T357 to obtain the AM-SIF response curve as shown in Fig. 26.
32.6	T357	B (peak)	

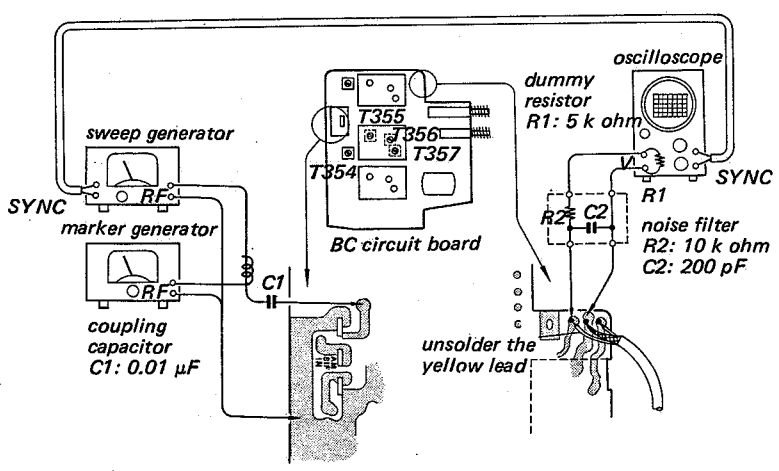

Fig. 25

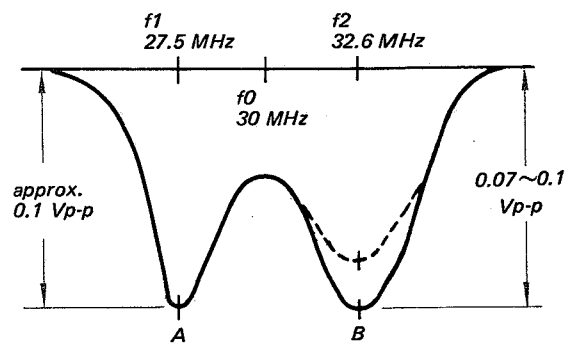
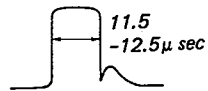
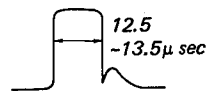

Fig. 26

Deflection Circuit Adjustments

Items	Preparations	Equipment	Connection	Adjust	Remarks
Collector current of Q703 (Vert. OUT)	<ol style="list-style-type: none"> 1. Set the push switch button to CCIR (625 lines). 2. Lock in sync. 3. Check 12V power supply. 4. Unsolder a green lead which is connected to the collector of Q703. 	ammeter	Between the green lead and the collector of Q703	Δ R711 (820 ~ 2.4 kohm)	for reading of 120 ~ 126 mA.
Vert. Height and Linearity	<ol style="list-style-type: none"> 1. Set the push switch button to CCIR (625 lines). 2. Receive a test pattern for CCIR (625 lines). 3. Check 12V power supply. 			VR702 & VR703	for obtaining the optimum vert. height and linearity.
Pulse-width F & B (819 lines)	<ol style="list-style-type: none"> 1. Set the push switch button to F & B (819 lines). 2. Receive a test pattern for F & B (819 lines). 3. Lock in sync. 			Δ C807 (0.001 - 0.01 μ F)	for pulse-width of 11.5 - 12.5 μ sec.  Horizontal pulse-width
Pulse-width CCIR (625 lines)	<ol style="list-style-type: none"> 1. Set the push switch button to CCIR (625 lines). 2. Receive a test pattern for CCIR (625 lines). 3. Lock in sync. 			Δ C808 (0.001 - 0.01 μ F)	for pulse-width of 12.5 - 13.5 μ sec.  Horizontal pulse-width
Horizontal Frequency F & B (819 lines)	<ol style="list-style-type: none"> 1. Set the push switch button to F & B (819 lines) 2. Receive a test pattern for F & B (819 lines). 3. Set the contrast and brightness controls to the optimum position. 			VR602	Adjust VR602 so that the number of diagonal bars are almost same for both extreme clockwise and counterclockwise settings of VR601 (H. hold).
Horizontal Frequency CCIR (625 lines)	<ol style="list-style-type: none"> 1. Set the push switch button to CCIR (625 lines). 2. Receive a test pattern for CCIR (625 lines). 3. Set the contrast and brightness controls to the optimum positions. 			VR603	Adjust VR603 so that the number of diagonal bars are almost same for both extreme clockwise and counterclockwise settings of VR601 (H. hold).

TERMINAL VIEW

Semiconductor

<p>2SC1127</p>	<p>SE5020</p>	<p>2SC629 2SC657 2SC633 2SC403A</p> <p>2SA677</p>
<p>2SD72</p>	<p>2SD292 2SC806A</p>	<p>2SA182 2SB324</p>
<p>HF SD - 1Z UF SD - 1A</p> <p>1T22A 1T261 1N60</p>	<p>1T243</p> <p>SB-2</p>	

E : Emitter
C : Collector
B : Base
S : Shield

SCHEMATIC DIAGRAM

Tuner circuit

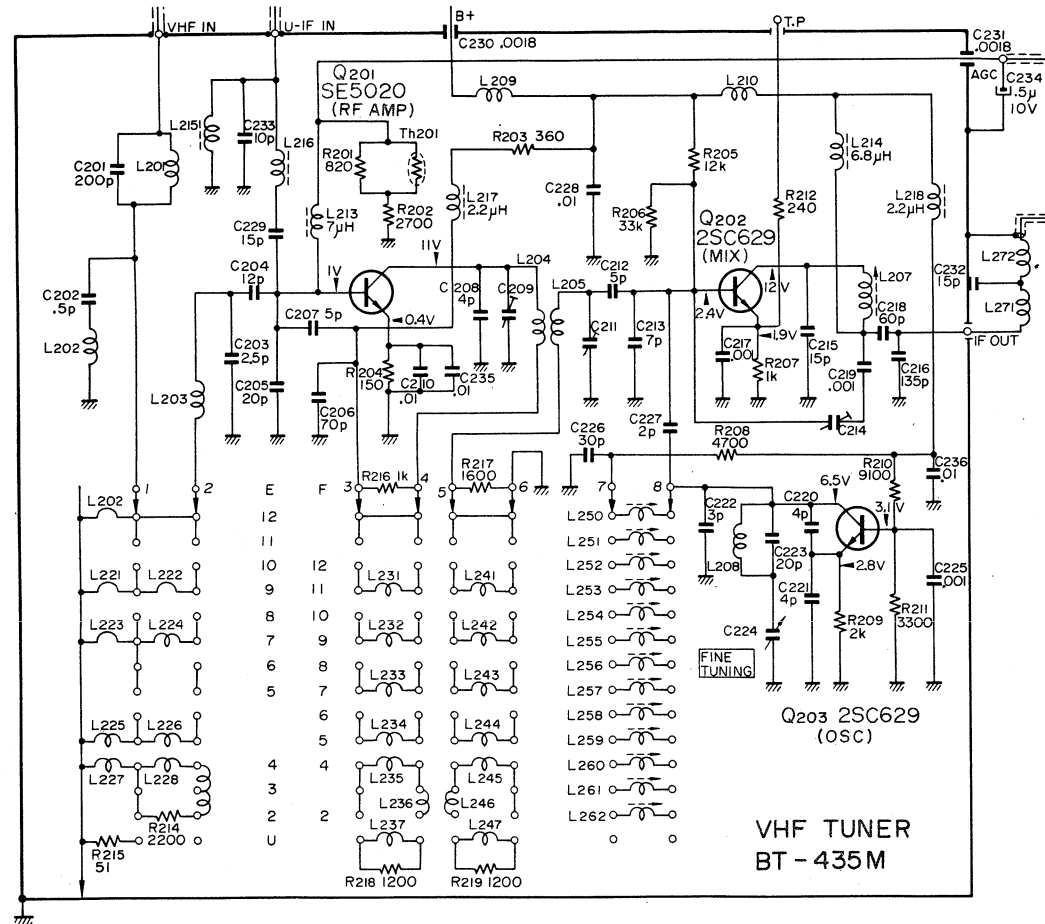

☆ Voltages measured from chassis to point indicated with a VOM (20k ohm/V), with no signal input.

MOUNTING DIAGRAM

VHF tuner circuit board
- Conductor side -

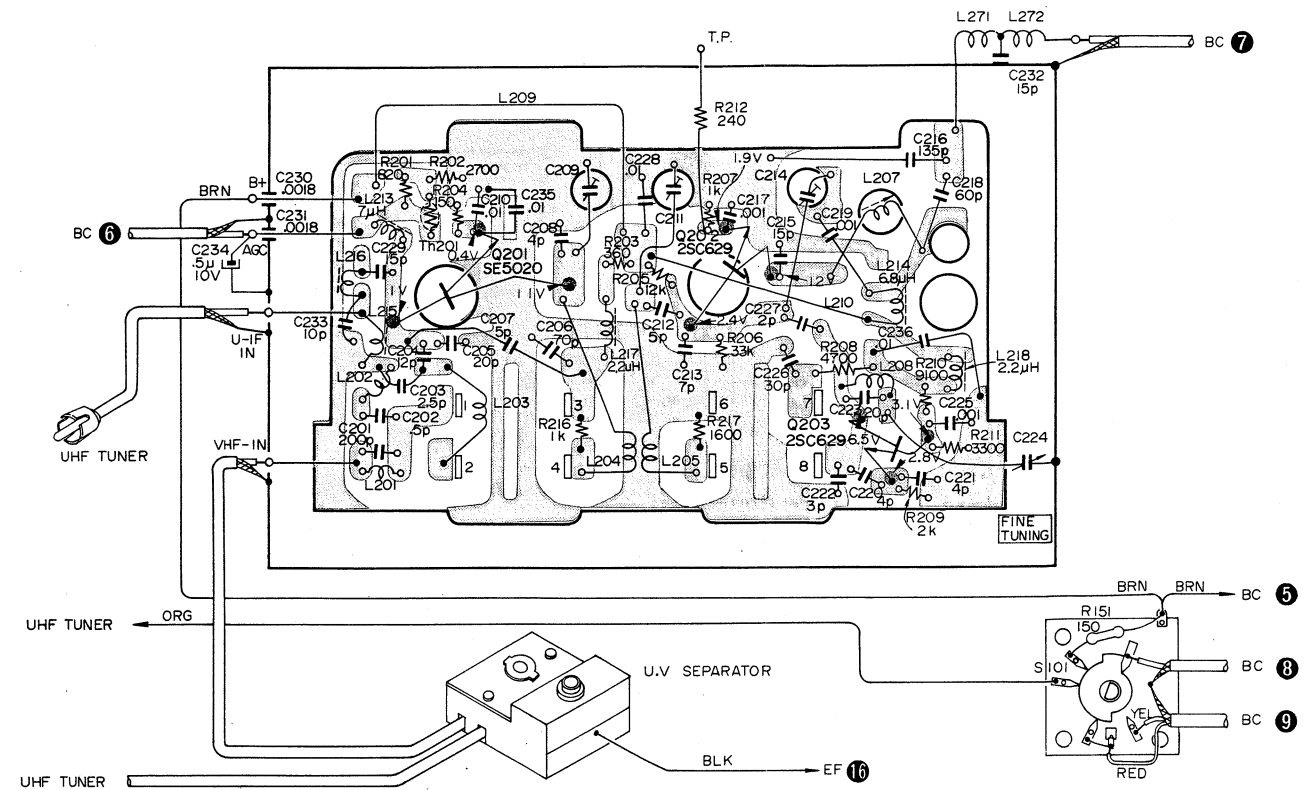

- Component side -

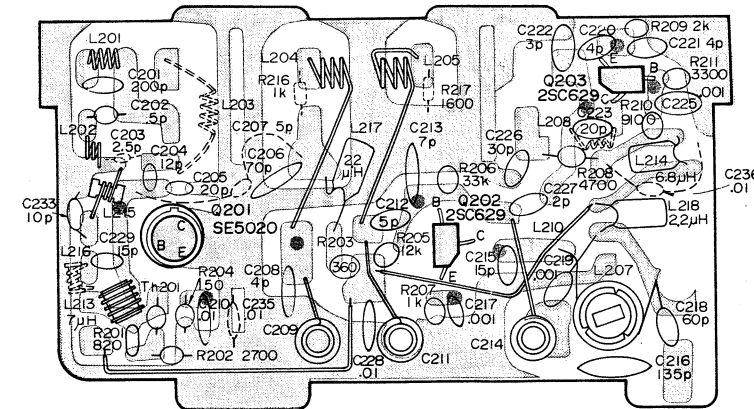

☆ Q201, Q202, Q203, L203, L208, L216, R216, R217, C203, C207, C235, C236: Mounted on the conductor side.
☆ Voltages measured from chassis to point indicated with a VOM (20k ohm/V), with no signal input.

TV9-90UM TV9-90UM

MOUNTING DIAGRAM

Signal circuit board (BC)

— Conductor side —

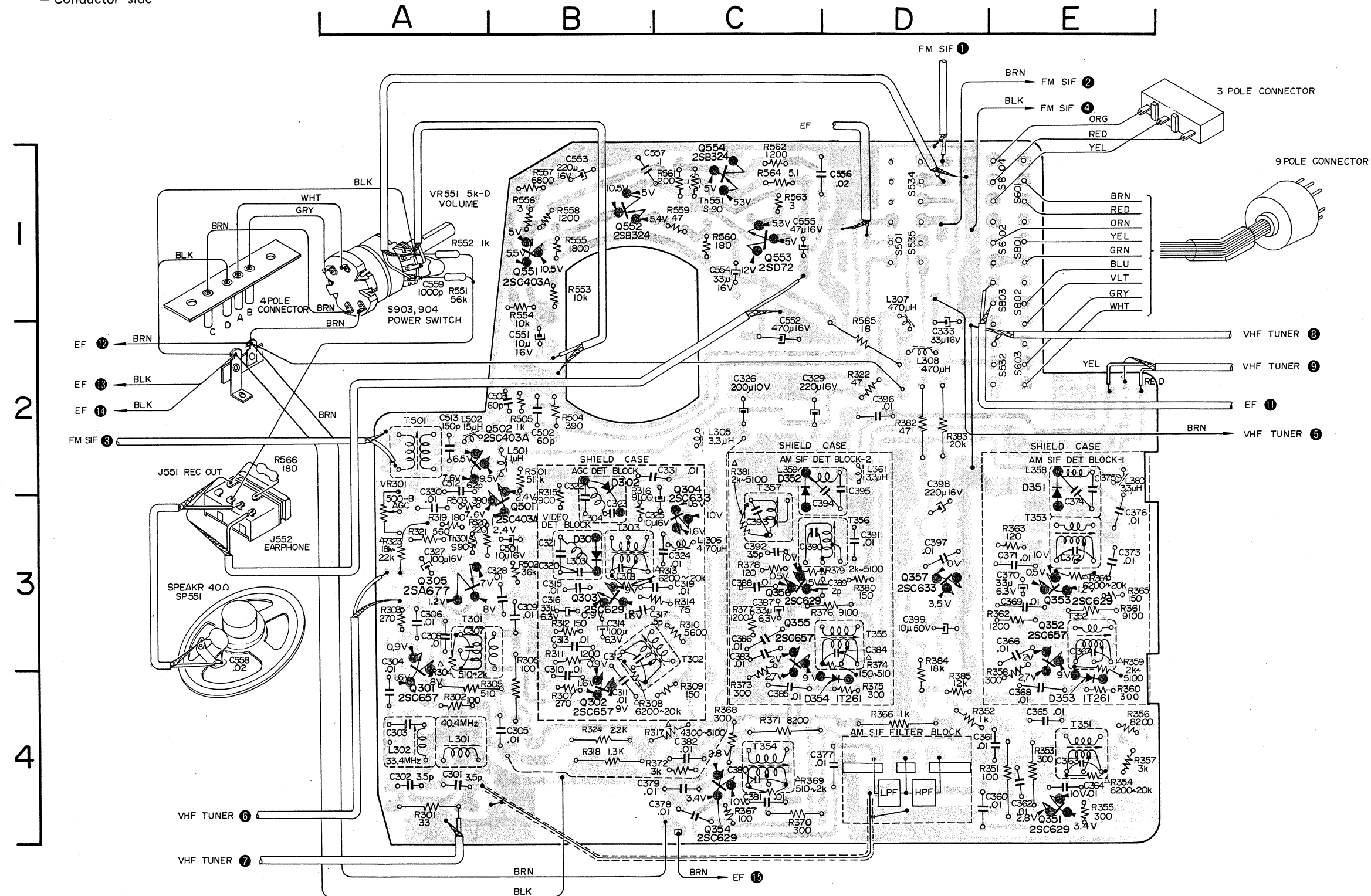

Symbol No.	Location
Q301	A-4
Q302	B-4
Q303	B-3
Q304	C-3
Q305	A-3
Q351	E-4
Q352	E-4
Q353	E-3
Q354	C-4
Q355	C-4
Q356	C-3
Q357	D-3
Q501	B-3
Q502	A-2
Q551	B-1
Q552	B-1
Q553	C-1
Q554	C-1
D301	B-3
D302	B-3
D351	E-3
D352	C-3
D353	E-4
D354	D-4
Th301	A-3
Th551	C-1
VR301	A-3
VR551	A-1

- ☆ R304, R308, R313, R323, R354, R359, R364, R369, R374, R379, R381: Mounted on the conductor side.
- ☆ Resistance values marked with Δ are to be selected.
- ☆ Voltages measured from chassis to point indicated with a VOM (20k ohm/V), with no signal input.

SCHEMATIC DIAGRAM

Signal circuit

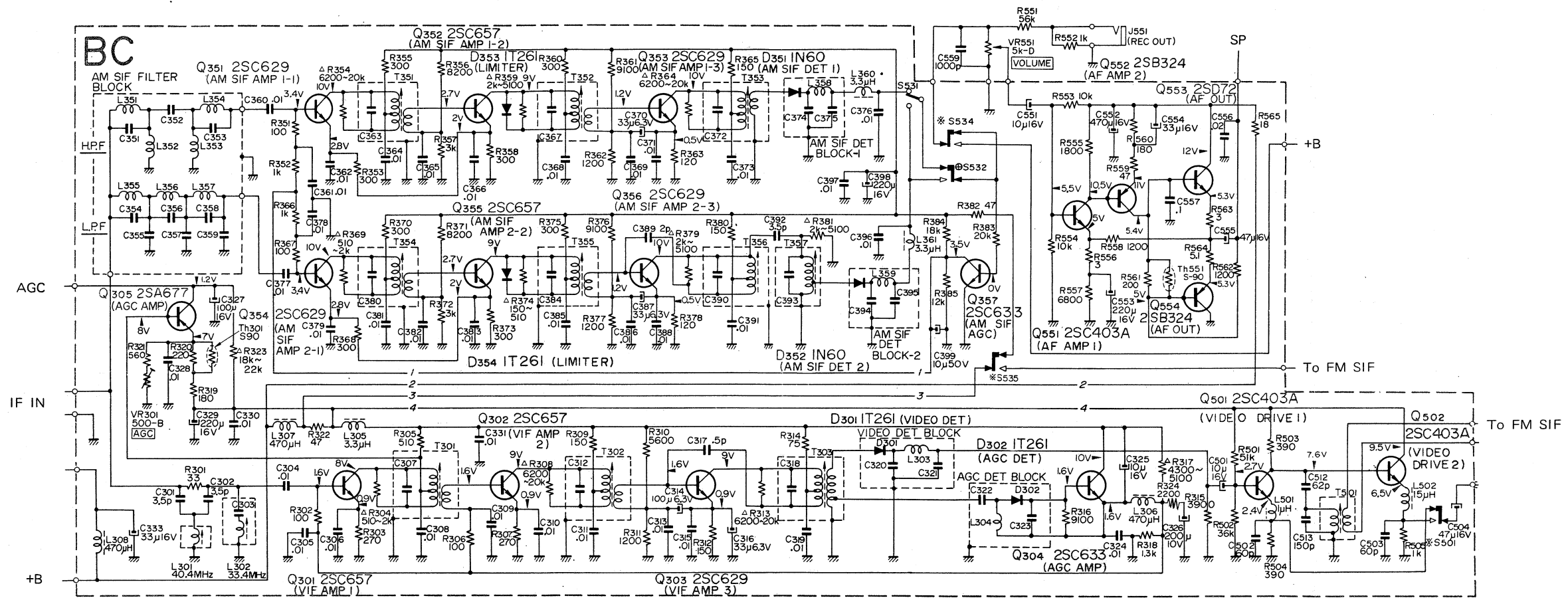

- * Resistance values marked with Δ are to be selected.
- * Voltages measured from chassis to point indicated with a VOM (20k ohm/V), with no signal input.

MOUNTING DIAGRAM

Signal circuit board (BC)

- Component side -

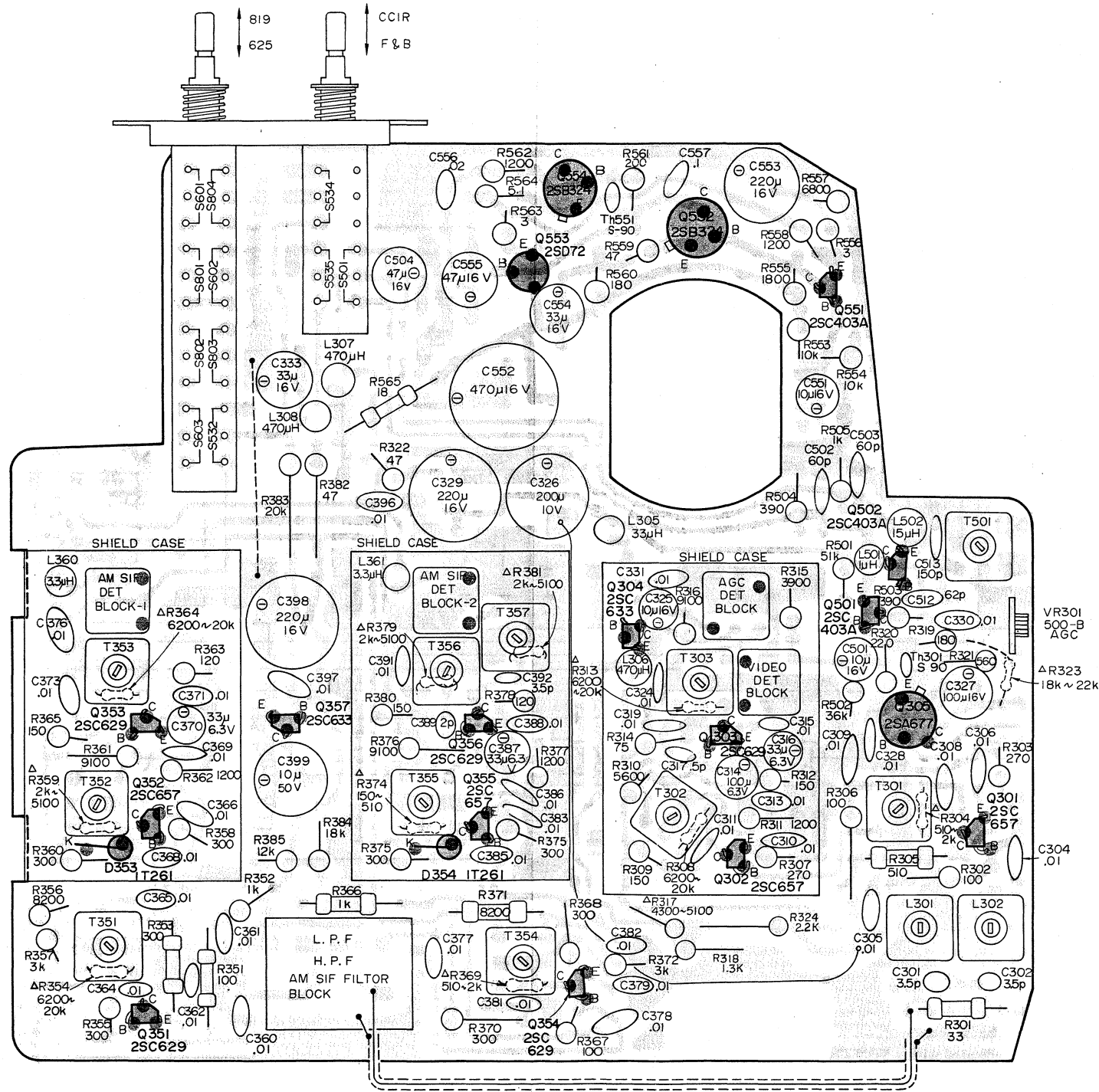

* R304, R308, R313, R323, R354, R359, R364, R369, R374, R379, R381: Mounted on the conductor side.
 * Resistance values marked with Δ are to be selected.

SCHEMATIC DIAGRAM

FM SIF circuit

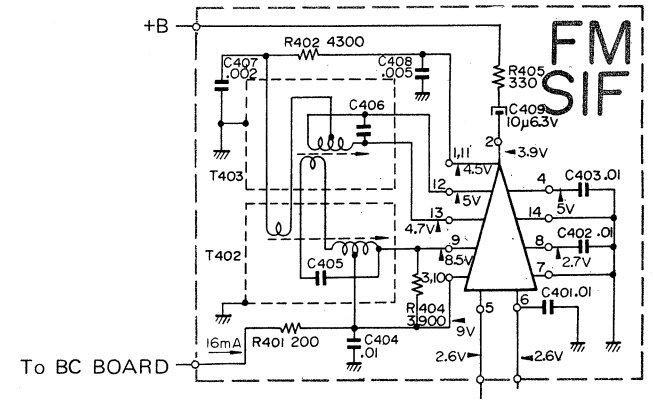

MOUNTING DIAGRAM

FM SIF circuit board
— Conductor side —

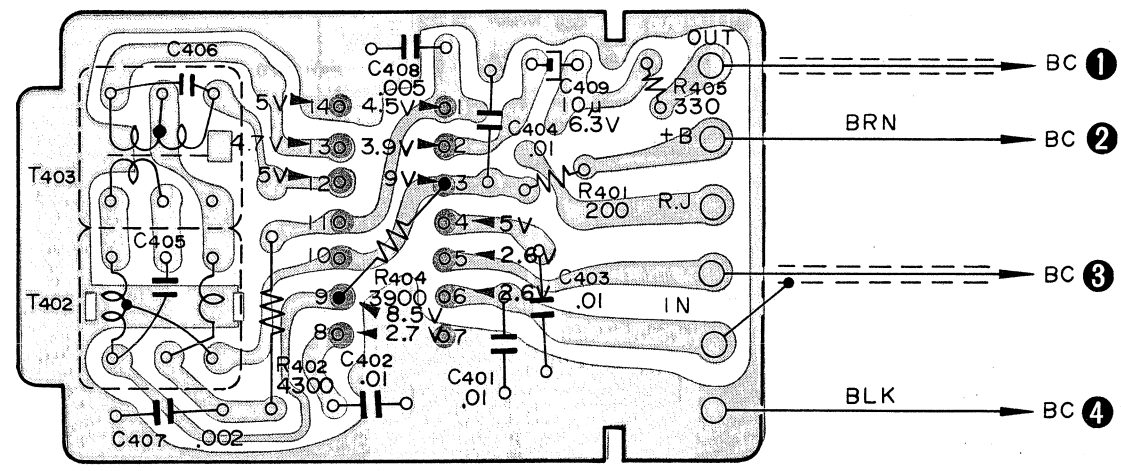

— Component side —

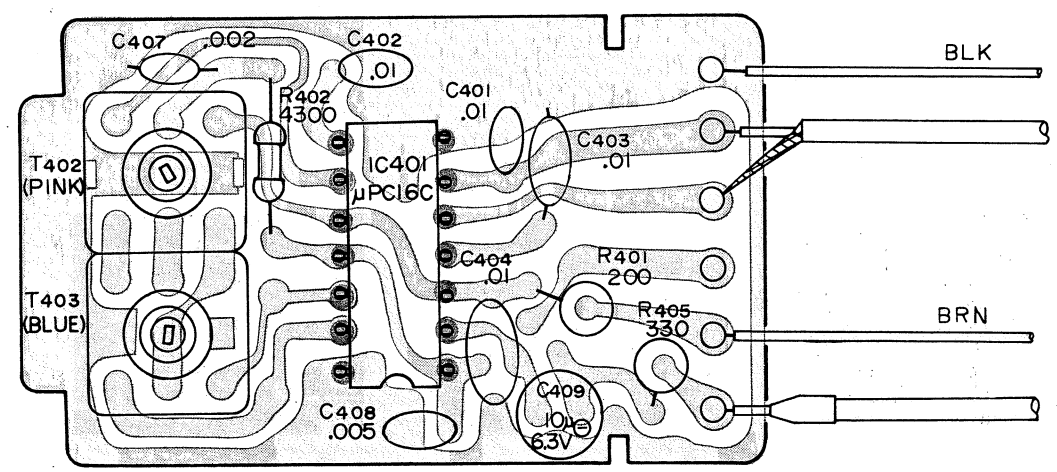

☆ R404: Mounted on the conductor side.
☆ Voltages measured from chassis to point indicated with a VOM (20k ohm/V), with no signal input.

MOUNTING DIAGRAM

Power supply block

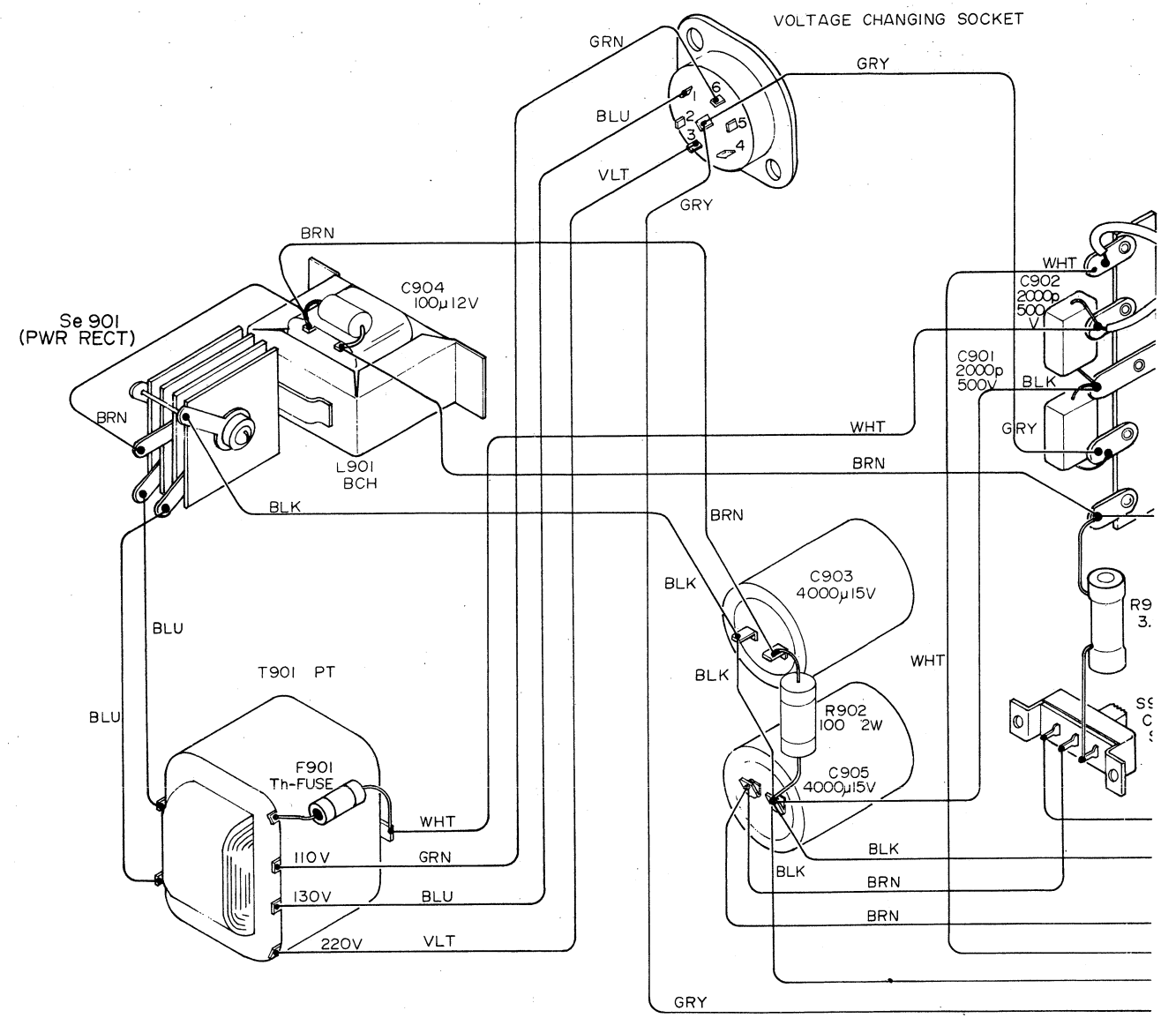

SCHEMATIC DIAGRAM

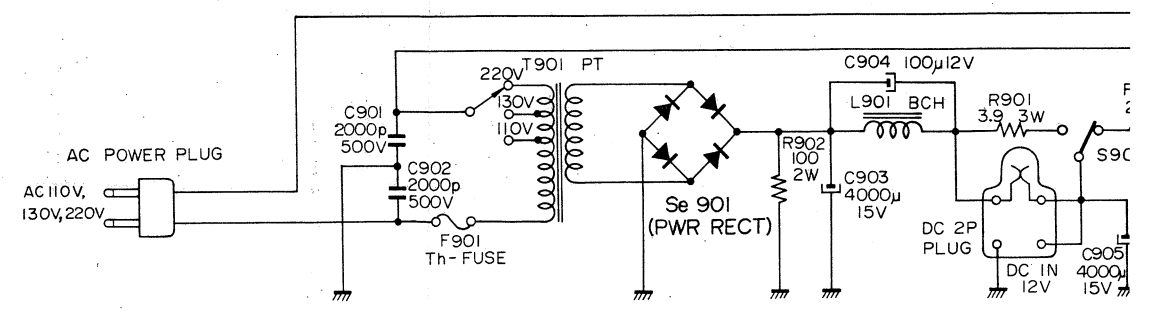

MOUNTING DIAGRAM

Power supply block

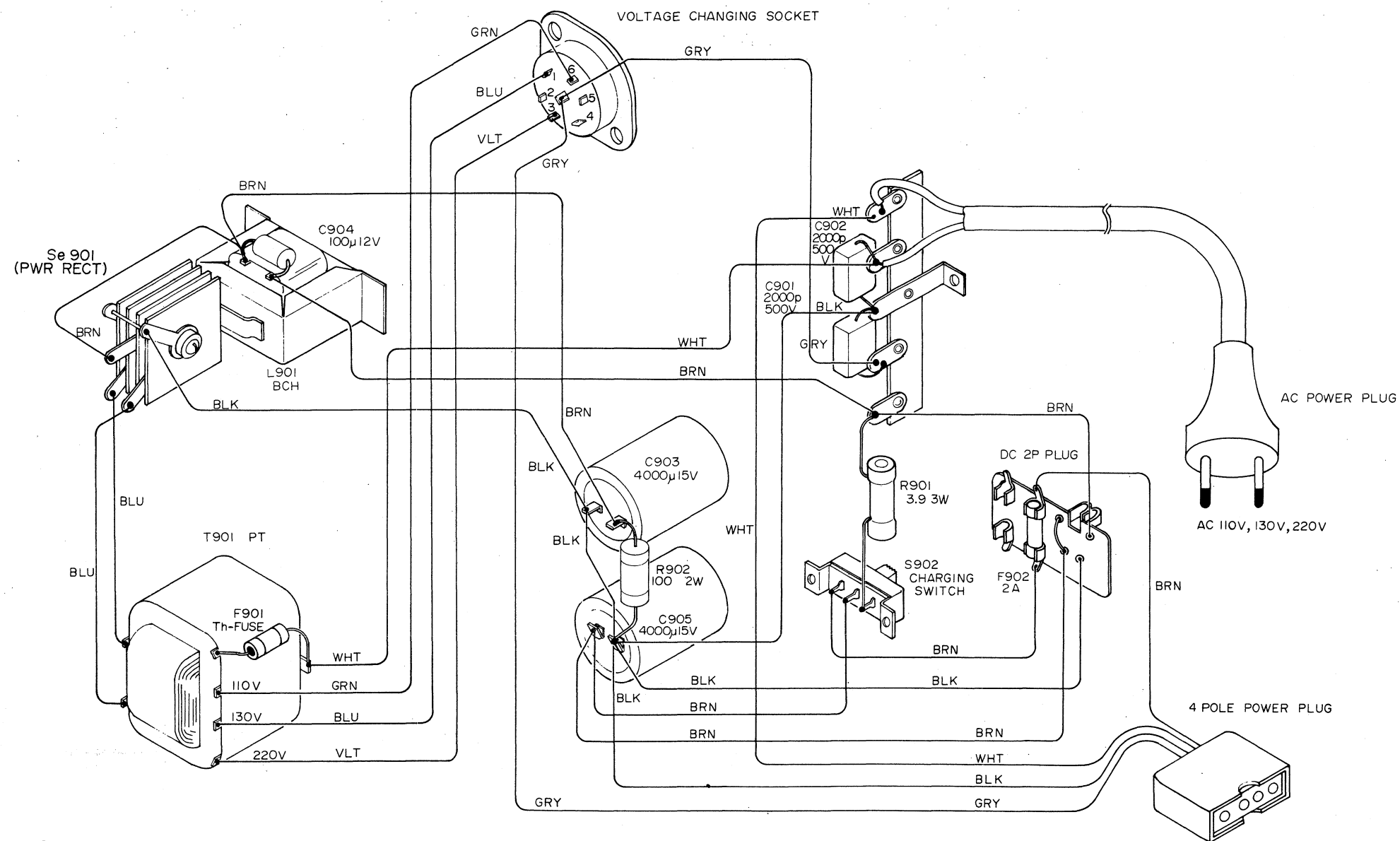
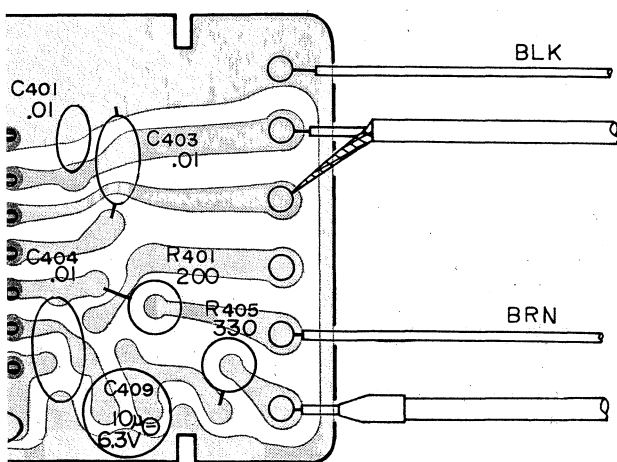
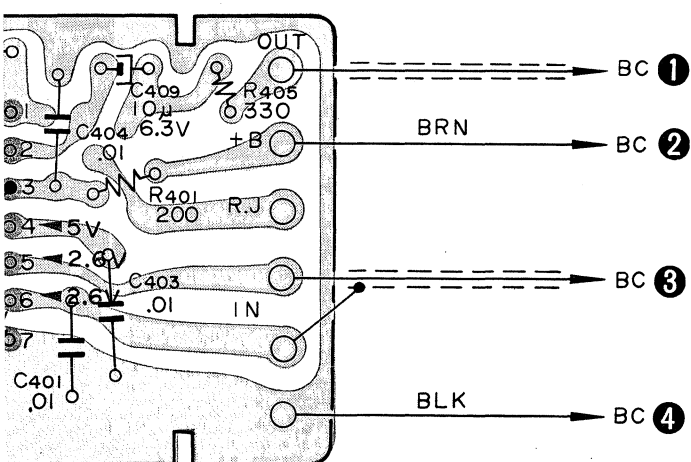
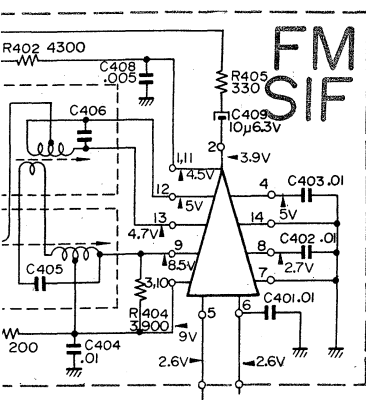

SHECMATIC DIAGRAM

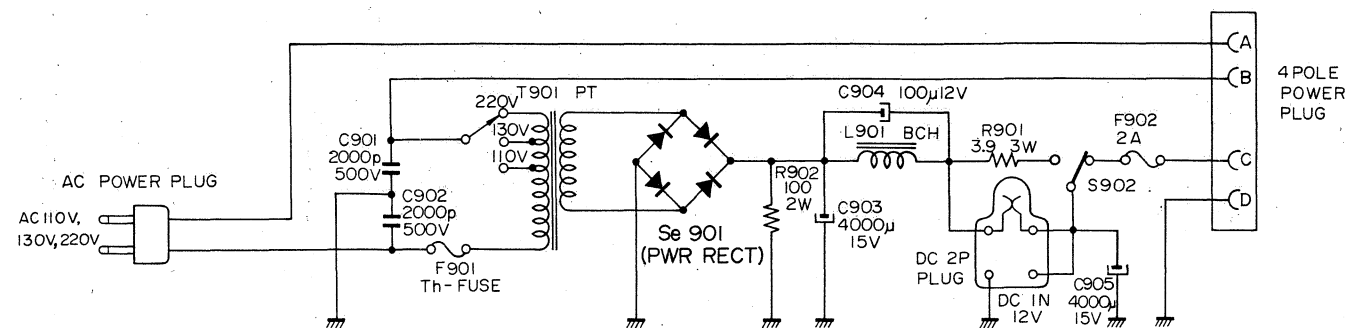

indicated with a VOM (20k ohm/V),

SCHEMATIC DIAGRAM

Deflection circuit

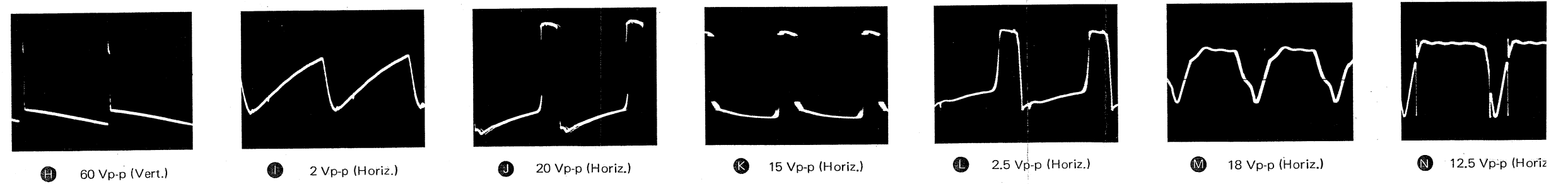
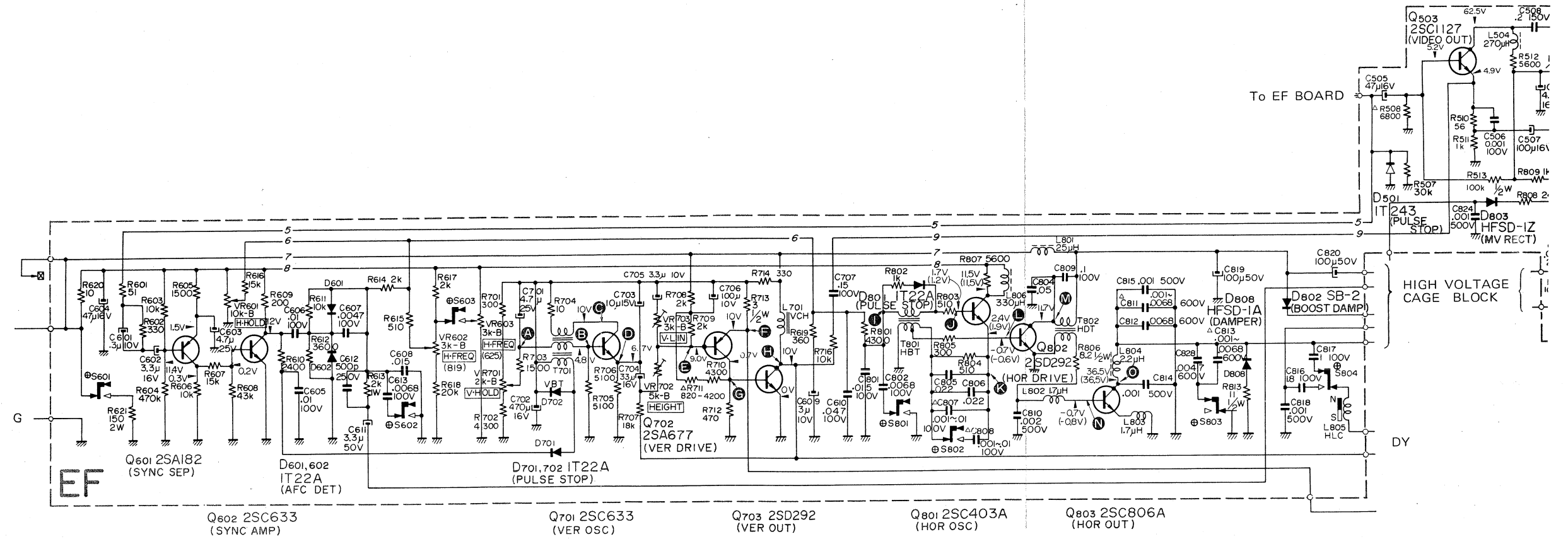
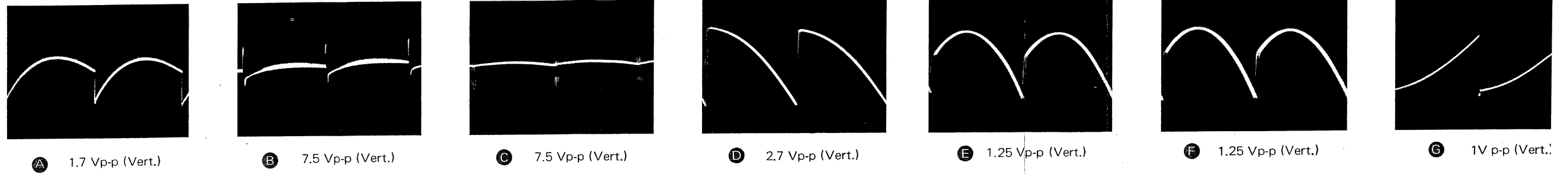

Voltages measured from chassis to point indicated with a VOM (20k ohm/V), with no signal input. The waveforms numbers (A ~ O) refer to the schematic diagram.

SCHEMATIC DIAGRAM

Deflection circuit



Vert.)

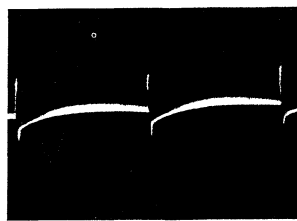

B 7.5 Vp-p (Vert.)

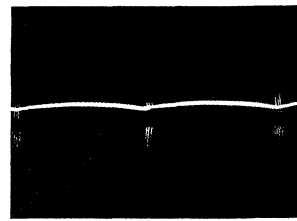

C 7.5 Vp-p (Vert.)

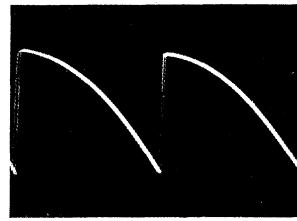

D 2.7 Vp-p (Vert.)

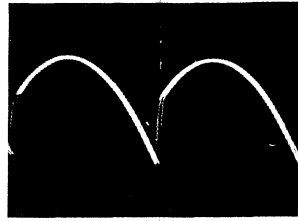

E 1.25 Vp-p (Vert.)

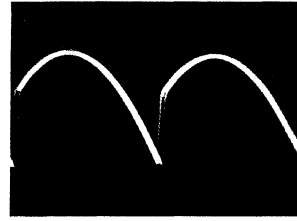

F 1.25 Vp-p (Vert.)

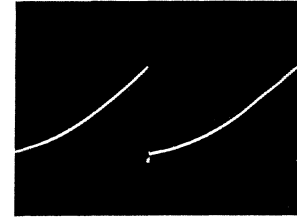

G 1V p-p (Vert.)

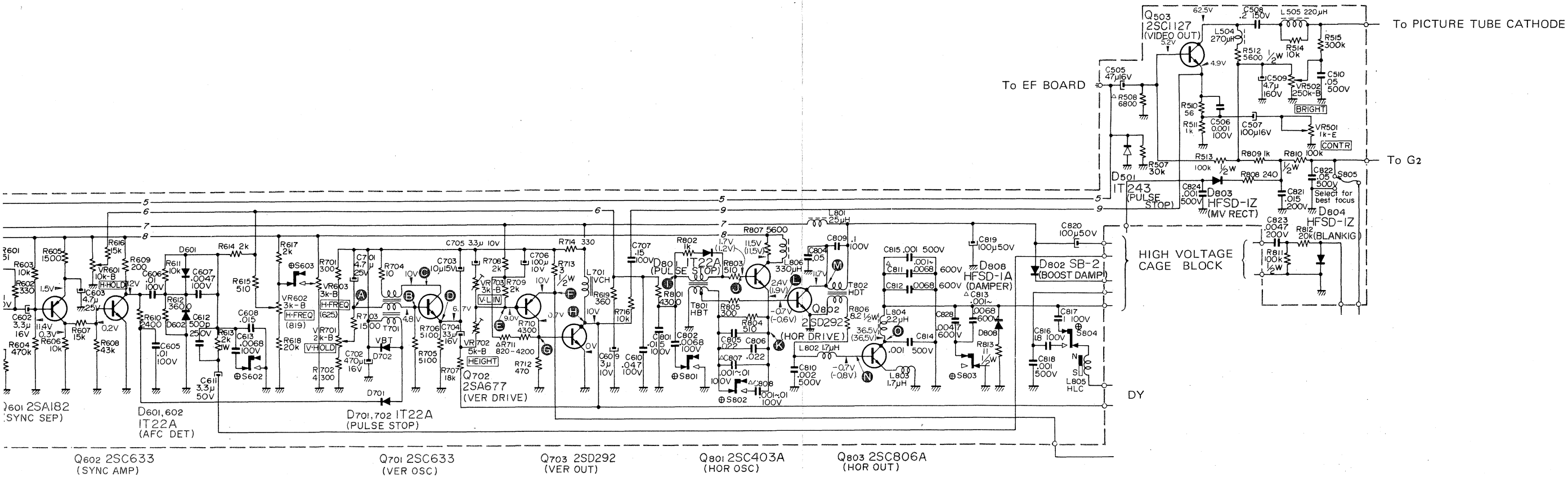

Vert.)

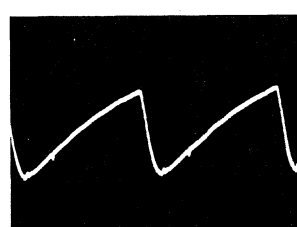

I 2 Vp-p (Horiz.)

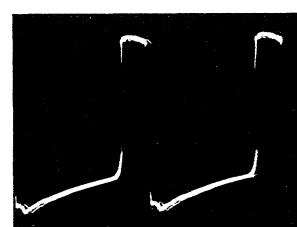

J 20 Vp-p (Horiz.)

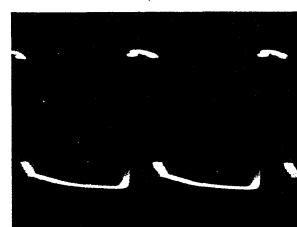

K 15 Vp-p (Horiz.)

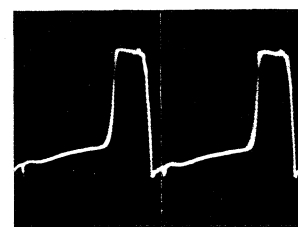

L 2.5 Vp-p (Horiz.)

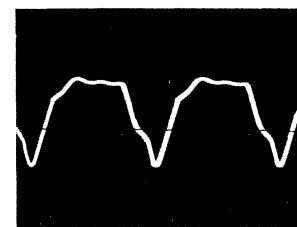

M 18 Vp-p (Horiz.)



N 12.5 Vp-p (Horiz.)

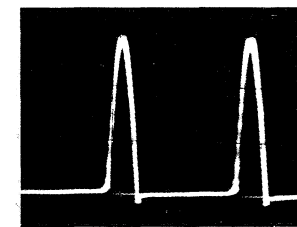

O 300 Vp-p (Horiz.)

Voltages measured from chassis to point indicated with a VOM (20k ohm/V), with no signal input. The waveforms numbers (A ~ O) refer to the schematic diagram.

MOUNTING DIAGRAM

Deflection circuit board
- Conductor side -

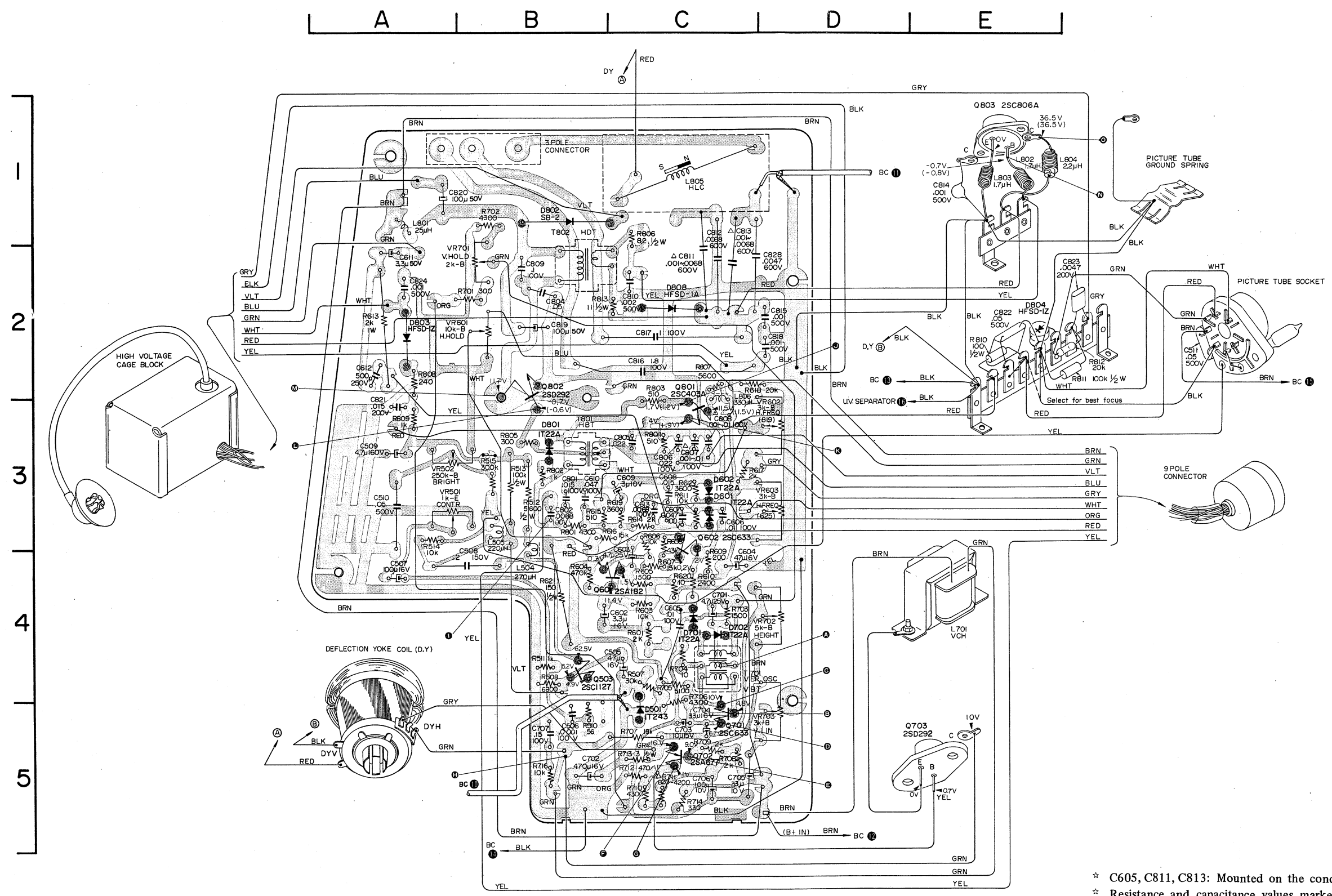

Symbol No.	Location
Q503	B-4
Q601	C-4
Q602	C-3
Q701	C-5
Q702	C-5
Q703	E-5
Q801	C-3
Q802	E-2
Q803	E-1
D501	C-4, 5
D601	C-3
D602	C-3
D701	C-4
D702	C-4
D801	B-3
D802	B-1
D803	A-2
D804	E-2
D808	C-2
VR501	A, B-3
VR502	A, B-3
VR601	B-2
VR602	D-3
VR603	D-3
VR701	B-2
VR702	D-4
VR703	D-4, 5

☆ C605, C811, C813: Mounted on the conductor side.
 ☆ Resistance and capacitance values marked with Δ are to be selected.
 ☆ Voltages measured from chassis to point indicated with a VOM (20k ohm/V), with no signal input.

- Component side -

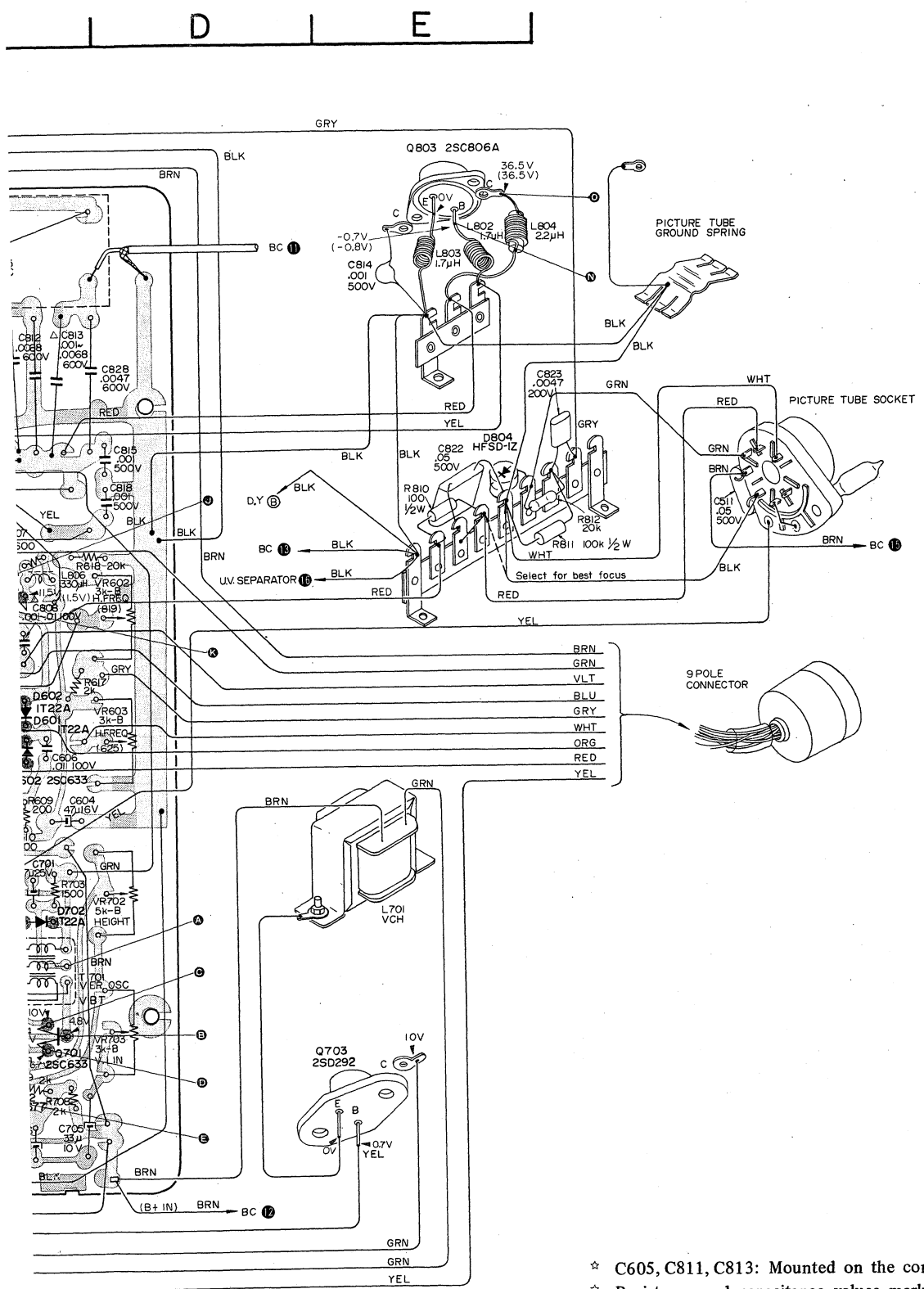

Symbol No.	Location
Q503	B-4
Q601	C-4
Q602	C-3
Q701	C-5
Q702	C-5
Q703	E-5
Q801	C-3
Q802	E-2
Q803	E-1
D501	C-4, 5
D601	C-3
D602	C-3
D701	C-4
D702	C-4
D801	B-3
D802	B-1
D803	A-2
D804	E-2
D808	C-2
VR501	A, B-3
VR502	A, B-3
VR601	B-2
VR602	D-3
VR603	D-3
VR701	B-2
VR702	D-4
VR703	D-4, 5

* C605, C811, C813: Mounted on the conductor side.
 * Resistance and capacitance values marked with Δ are to be selected.
 * Voltages measured from chassis to point indicated with a VOM (20k ohm/V), with no signal input.

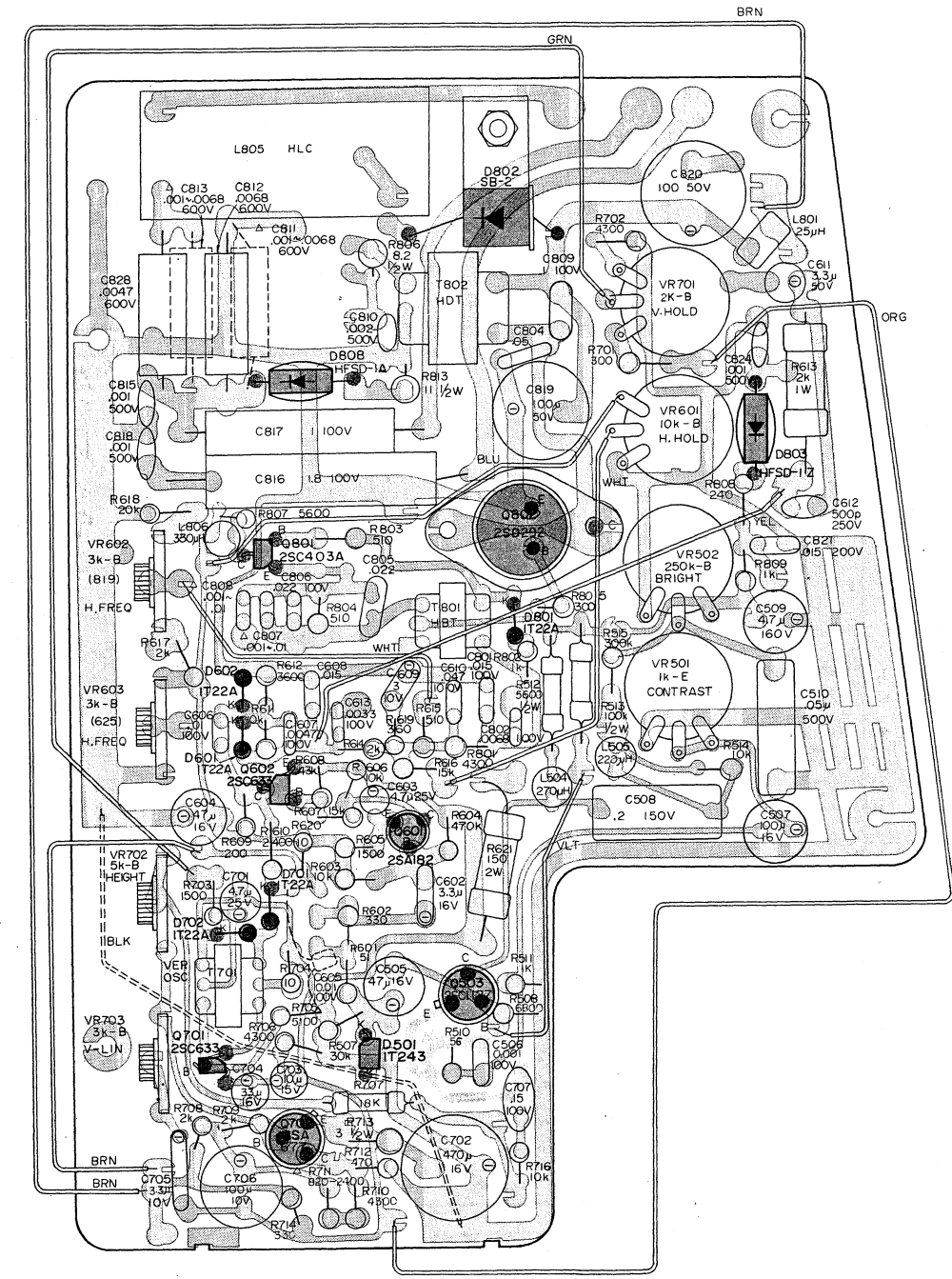

* C605, C811, C813: Mounted on the conductor side.
 * Resistance and capacitance values marked with Δ are to be selected.

SCHEMATIC DIAGRAM

- Overall -

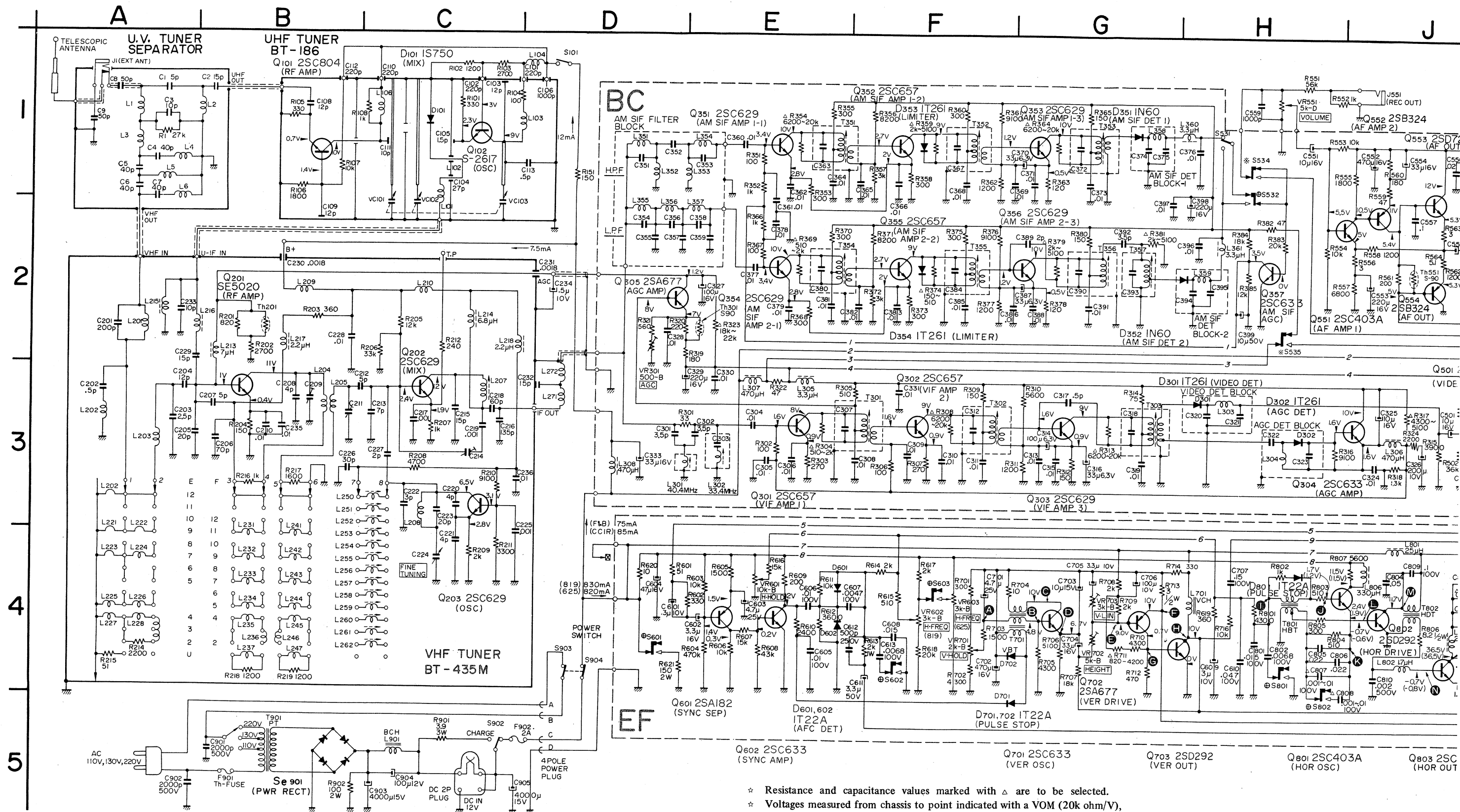

* Resistance and capacitance values marked with Δ are to be selected.
 * Voltages measured from chassis to point indicated with a VOM (20k ohm/V), with no signal input and the values shown in () are taken with push switch set to 819.

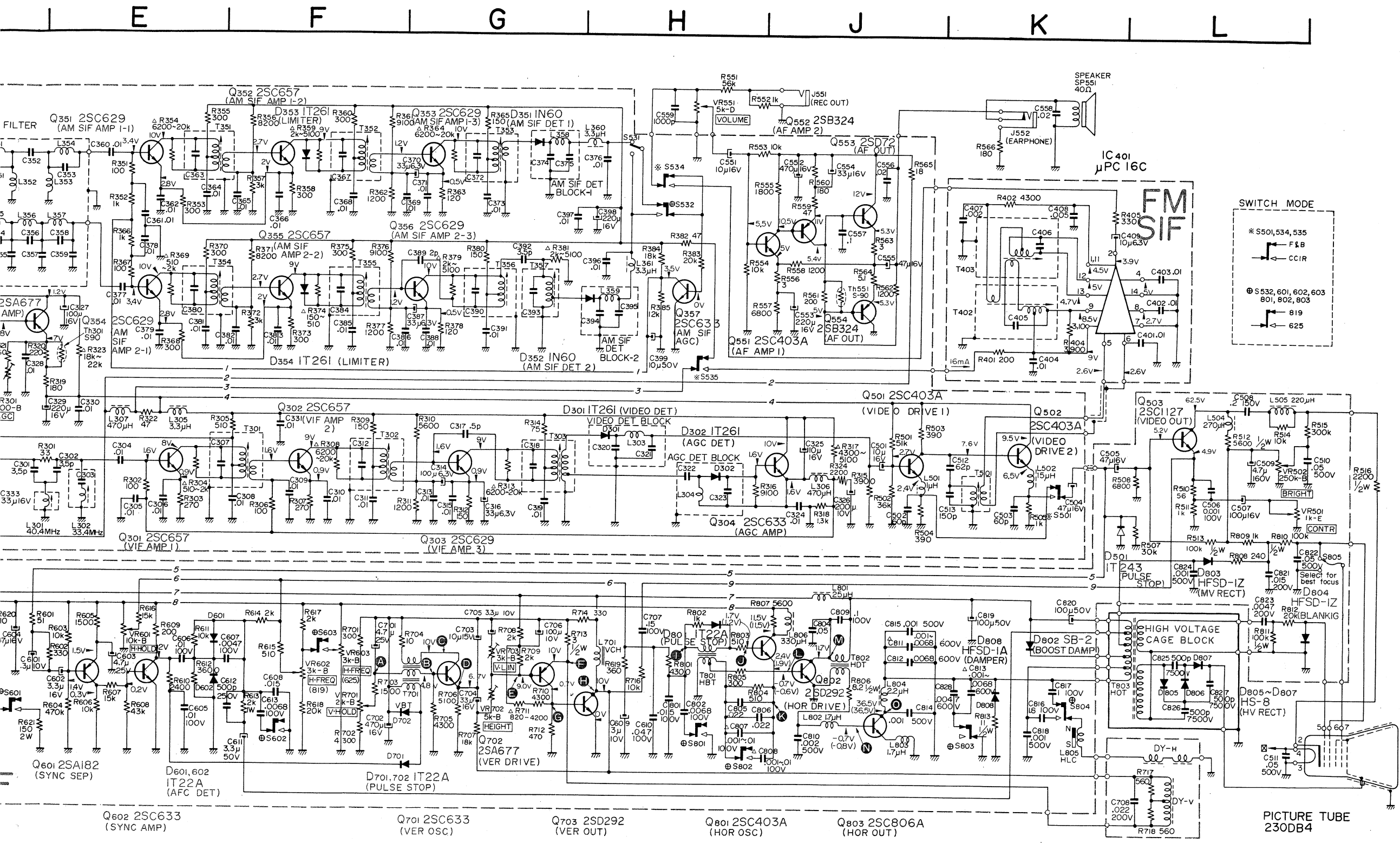

Symbol No.	Location
IC401	K, L-2
Q101	B-1
Q102	C-1
Q201	B-3
Q202	C-3
Q203	C-3
Q301	E-3
Q302	F-3
Q303	G-3
Q304	J-3
Q305	D-2
Q351	E-1
Q352	F-1
Q353	G-1
Q354	E-2
Q355	F-2
Q356	G-2
Q357	H-2
Q501	J-3
Q502	K-3
Q503	L-3
Q551	H, J-2
Q552	J-2
Q553	J-1, 2
Q554	J-2
Q601	E-4
Q602	E-4
Q701	G-4
Q702	G-4
Q703	G, H-4
Q801	H, J-4
Q802	J-4
Q803	J-4
D101	G-1
D301	H-3
D302	H-3
D351	G-1
D352	H-2
D353	F-1
D354	F-2
D501	K, L-3
D601	E-4
D602	E-4
D701	F, G-4
D702	F, G-4, 5
D801	H-4
D802	K-4
D803	L-3
D804	L, M-4
D805	L-4
D806	L-4
D807	L-4
D808	K-4
Se901	B-4
Th201	B-2
Th301	E-2
Th551	J-2
VR301	D-2
VR501	L, M-3
VR502	L-3
VR551	H-1
VR601	E-4
VR602	F-4
VR603	F-4
VR701	F-4
VR702	G-4
VR703	G-4

* Resistance and capacitance values marked with Δ are to be selected.
 * Voltages measured from chassis to point indicated with a VOM (20k ohm/V), with no signal input and the values shown in () are taken with push switch set to 819.

TV9-90UM TV9-90UM

EXPLODE VIEW (1)

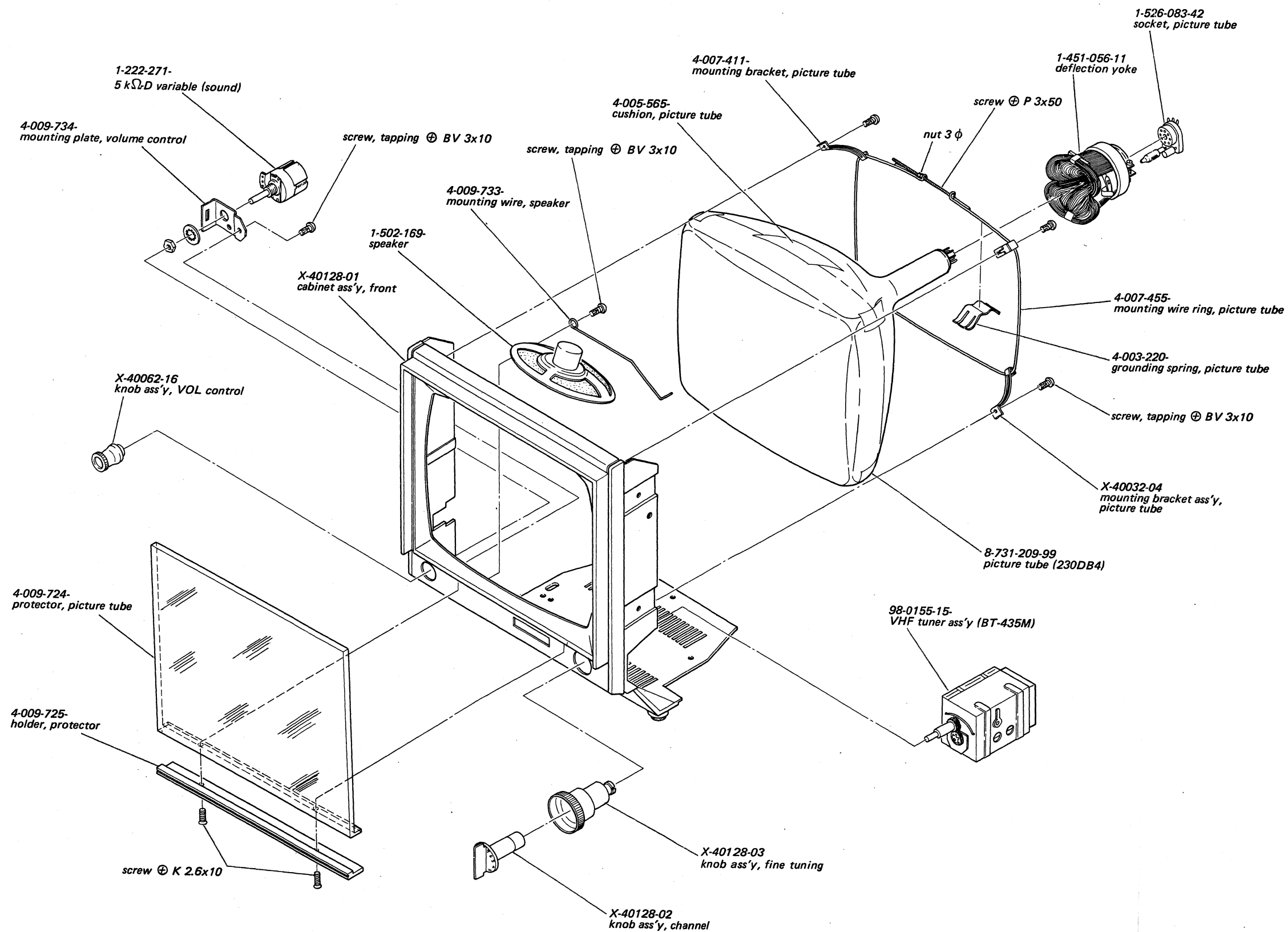

TV9-90UM TV9-90UM

EXPLODED VIEW (2)

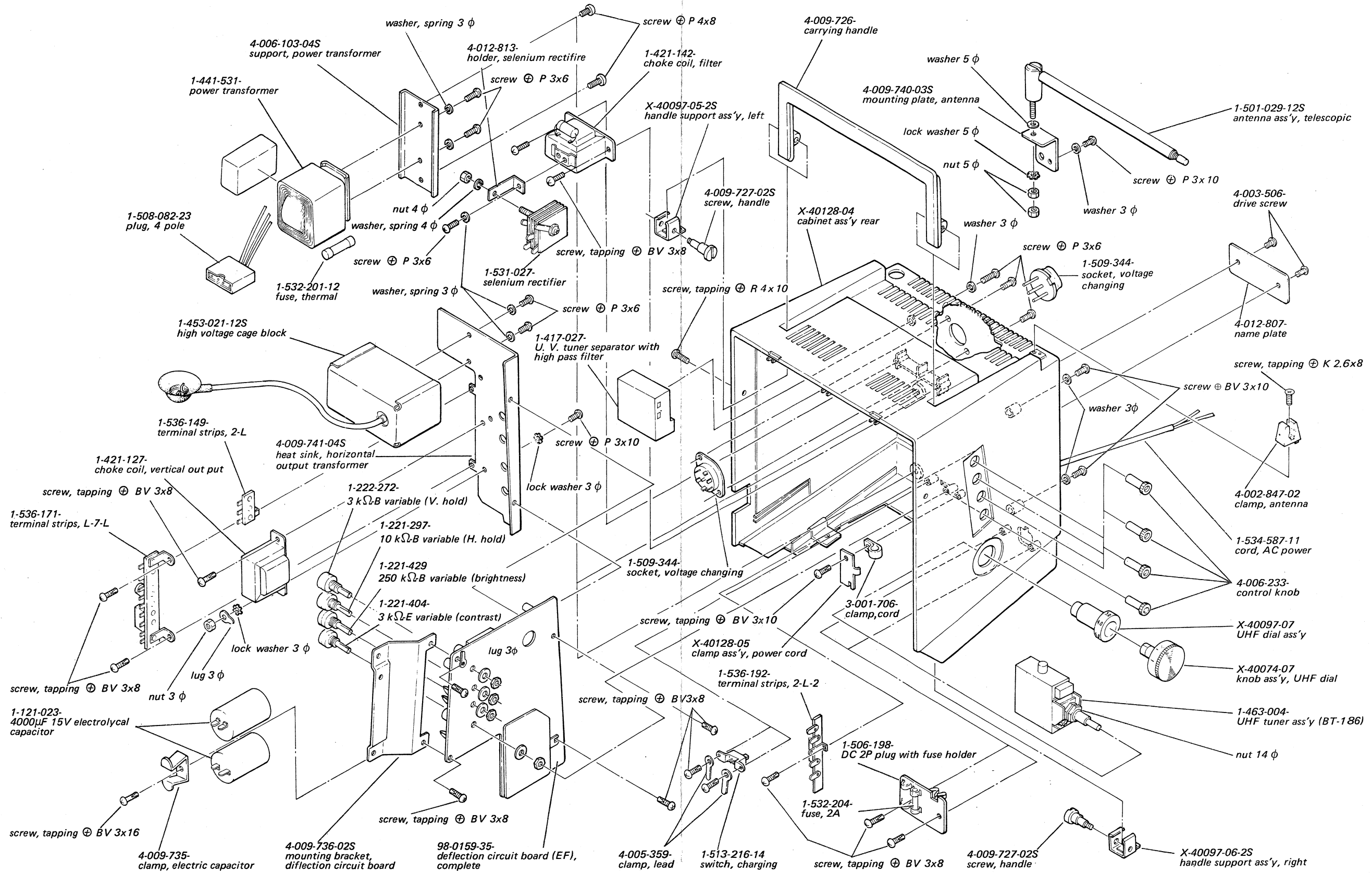

TV9-90UM TV9-90UM

EXPLODE VIEW (3)

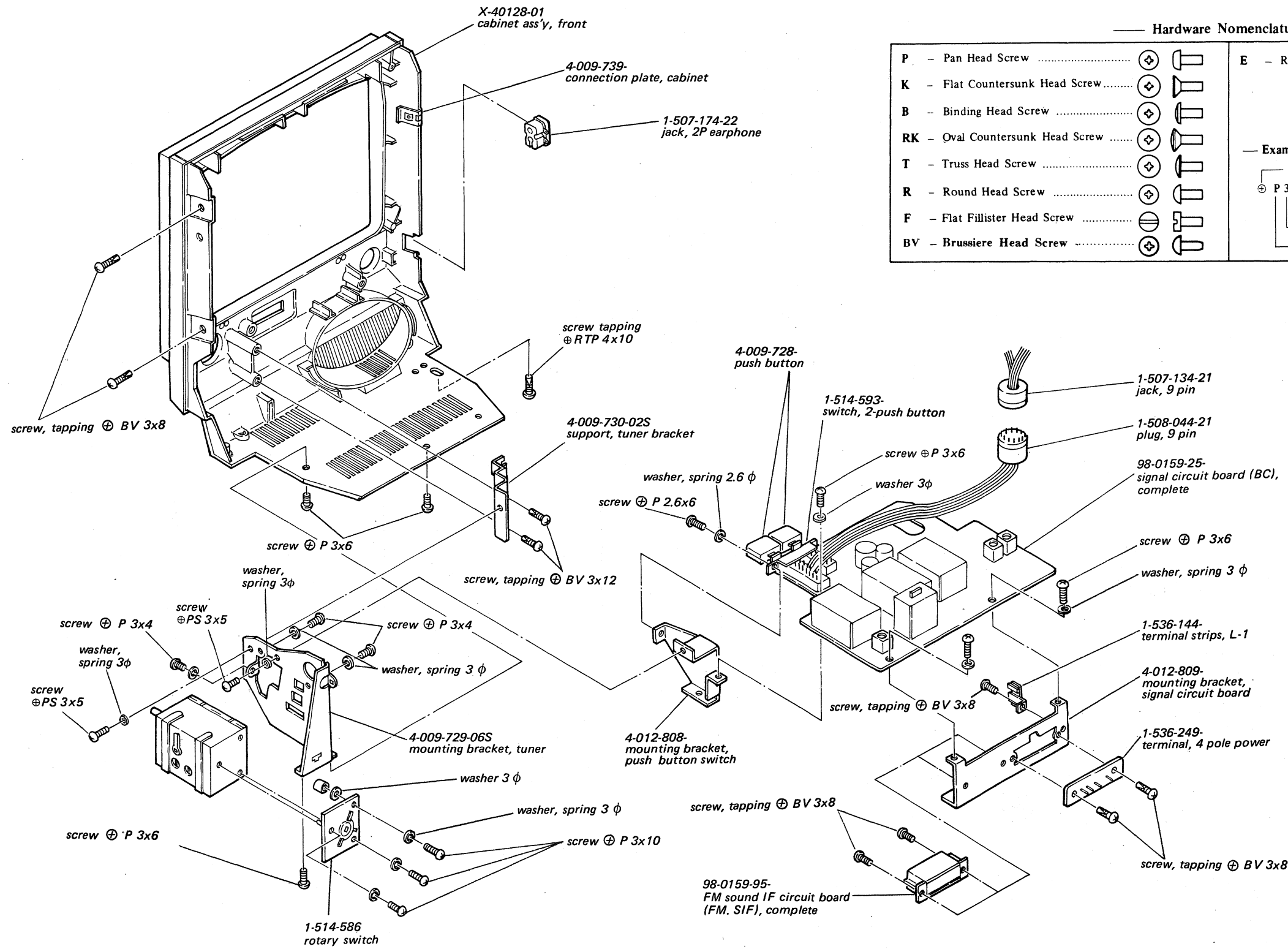

Hardware Nomenclature

P	- Pan Head Screw	
K	- Flat Countersunk Head Screw	
B	- Binding Head Screw	
RK	- Oval Countersunk Head Screw	
T	- Truss Head Screw	
R	- Round Head Screw	
F	- Flat Fillister Head Screw	
BV	- Brussiere Head Screw	
E	- Retaining Ring (E Washer)	
	W	- Washer
	SW	- Spring Washer
	LW	- Lock Washer
	N	- Nut

Example

Type of Slit: \oplus P 3 x 10

Length in mm (L):

Diameter in mm (D):

Type of Head:

PACKING

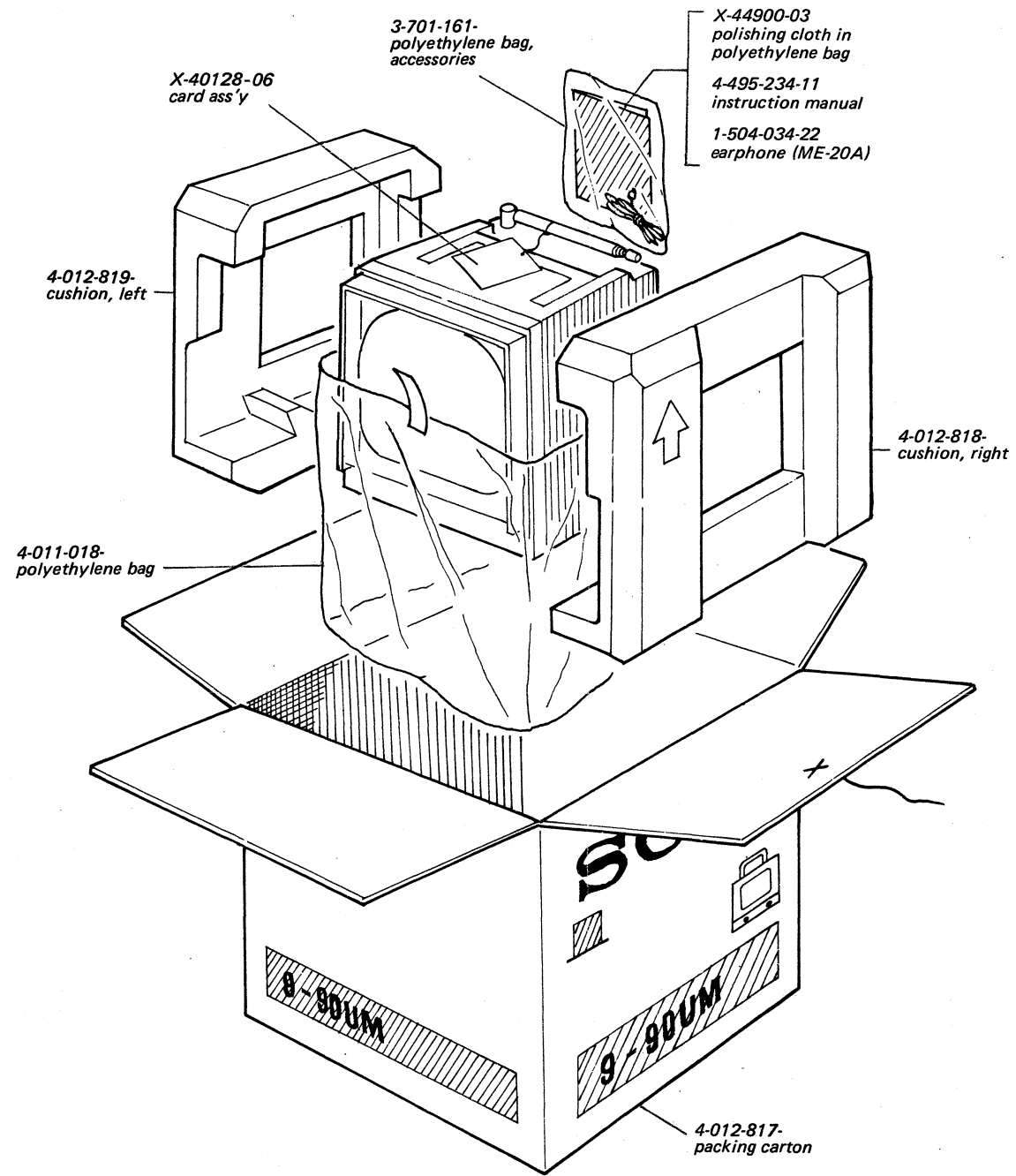

When ordering replacement parts, you should use PART NUMBER listed on the Complete Spare Parts List or shown in the Exploded View. The symbol number should not be used for ordering purposes.

SONY CORPORATION