

6025

marantz

model 6025

Turntable

marantz

MARANTZ DESIGN AND SERVICE

Using superior design and selected high grade components, MARANTZ Company has created the ultimate in stereo sound. Only original MARANTZ parts can insure that your MARANTZ product will continue to perform to the specifications for which it is famous.

Parts for your MARANTZ stereo are generally available within 72 hours throughout the nation via a toll-free line to our National Parts Depot in California. The sales professionals who take your call immediately refer to their own desk top computer terminal and can quickly determine the availability and price information you require. If for some reason, your order should exceed our available stock, we usually can instantly provide an alternate replacement part or current delivery information. When the order is placed and confirmed, the computer simultaneously generates "hard copy" orders at the distribution center. As hard copies come directly from the computer to the national parts depot, your requested stock is assembled and prepared for shipment and placed on the first available carrier for delivery to you.

ORDERING PARTS

Phone orders will eliminate mail delays, and we encourage the use of this method. If you order by mail, use MARANTZ parts order forms which are available from our National Parts Depot located at the following address:

SUPERSCOPE NATIONAL PARTS DEPARTMENT
20525 Nordhoff Street
Chatsworth, California 91311
Phone: 1-800-423-5108
1-213-998-9333

The following information must be supplied to eliminate delays in processing your order:

1. Complete address.
2. Complete part numbers.
3. Complete description of parts.
4. Model number for which part is required (indicate MARANTZ).
5. Account number (for account customers only).

Direct consumers will be provided with the current retail price quotation on available parts in order to advise them of the cost of the parts and shipping.

OVERSEAS PARTS ORDERING

Parts may also be ordered from the following overseas addresses:

CANADA

Superscope Canada, Ltd.
3710 Nashua Drive
Mississauga
Ontario, Canada L4V1M5

AUSTRALIA

Superscope (Australasia) Pty., Ltd.
32 Cross Street (P.O. Box 604)
Brookvale 2100 N.S.W.
Australia

JAPAN

Marantz Japan, Inc.
3622 Kamitsuruma
Sagamihara Shi
Kanagawa, Japan

EUROPE

Superscope Europe, S.A.
Avenue Leopold III, 2
7120 Perennes-Lez-Binche
Belgium

Marantz France
Rue Louis Armand 9
92600 Asnieres
Hauts-de-Seine
France

Marantz Audio U.K. Ltd.
London Road, 203
Staines
Middlesex
England

Superscope GmbH
Max-Planck-Strasse 22
D-6072 Dreieich 1
West Germany

All of the above locations are fully equipped to take care of your total service needs. Because various countries have differing configuration requirements, it is necessary that you contact the service facility in your particular country. In the event that there is no service location listed for your country, please contact the nearest facility for the necessary assistance.

marantz

We sound better.

TABLE OF CONTENTS

Section	Title	Page
1.	PERFORMANCE SPECIFICATIONS	2
2.	TONE ARM ADJUSTMENTS	3
2-1.	Stylus Tracking Angle	3
2-2.	Stylus Overhang	3
2-3.	Vertical Tone Arm Balance	4
2-4.	Tracking Force	4
2-5.	Anti-Skating Adjustment	4
3.	SERVICE NOTES	5
3-1.	Voltage Conversion (European Model only)	5
3-2.	Cartridge Wire Color Code	5
3-3.	Replacement Parts / Technical Assistance	5
4.	DIAGRAM	6
4-1.	Schematic Diagram	6
5.	EXPLODED VIEWS / PARTS LIST	7
5-1.	[C01-99] Wood Case, Covers and General Parts	7
5-2.	[P01-99] Turntable and Motor	8
5-3.	[P02-99] Tone Arm	9
5-4.	[P03-99] Parts Assembled on the Chassis	10
5-5.	[H01-99] Packing Materials	11



1. PERFORMANCE SPECIFICATIONS

GENERAL

Speeds: 33, 45 rpm
 Speed Range: ±1.3%
 Drive System: Belt Drive
 Drive Motor: 4-Pole Synchronous AC Motor
 Platter Weight: 1.5 lbs. (670 g)
 Platter Diameter: 11-13/16 in. (300 mm)
 Rumble (DIN): -65 dB
 Wow and Flutter: 0.07%
 Power Requirements: 120V AC, 60 Hz (USA and Canada Model)
 110-120/220-240 V AC
 50 Hz (European Model)
 Power Consumption: 10 Watts
 Dimensions: 17-7/8 in. Wide x 5-1/8 in. High x 13-15/16 in. Deep
 (454 mm x 130 mm x 354 mm)
 Weight: 10.6 lbs. (4.8 kg) Unpacked
 14.3 lbs. (6.5 kg) Packed for Shipment.

tone ARM

Length: 8-1/2 in. (216 mm)
 Overhang: 21/32 in. (17 mm)
 Tracking Force Adjustment Range: 0-3.0 g
 Anti-Skating Force Compensation Range: 0-4 g

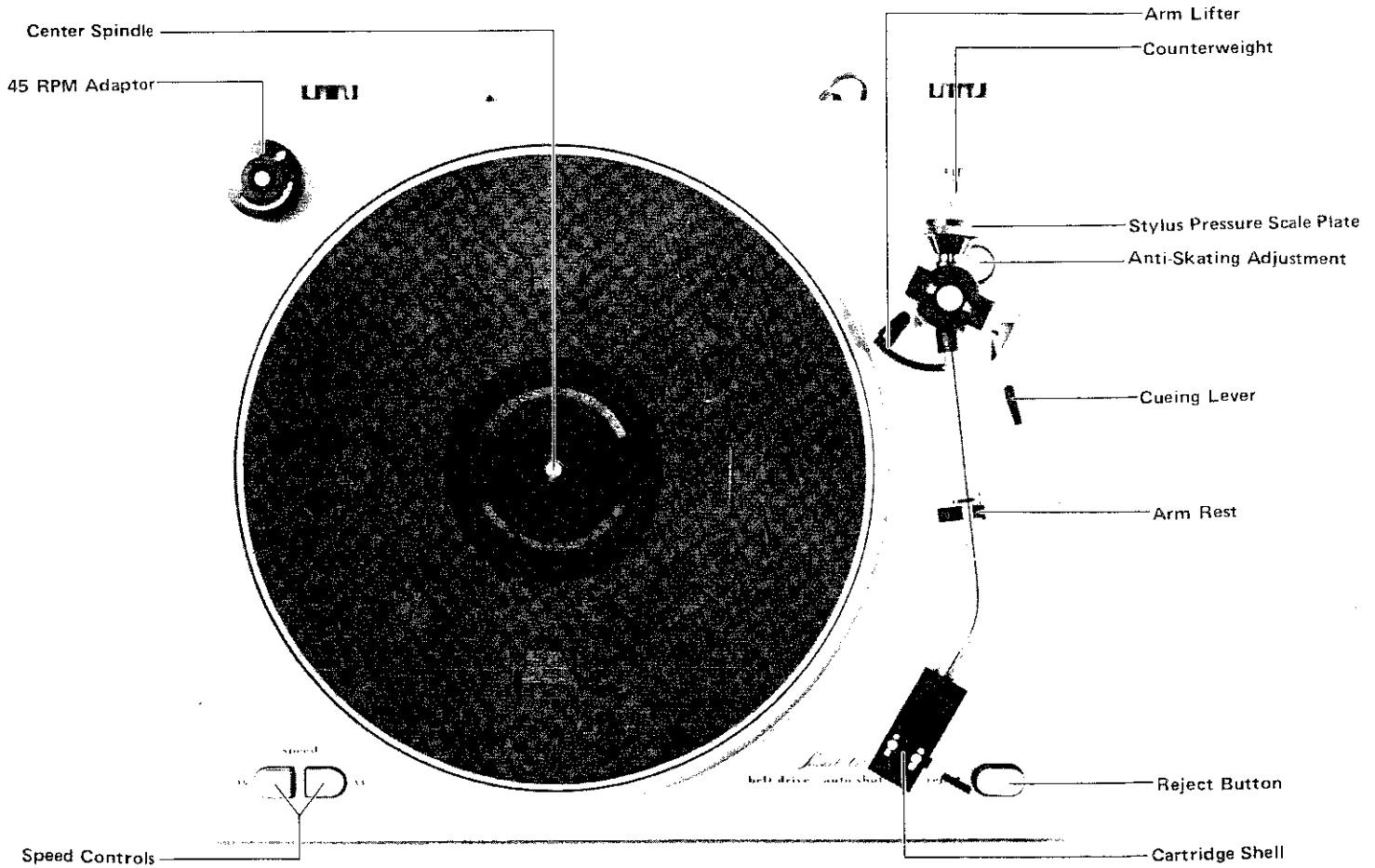

X

2. TONE ARM ADJUSTMENTS

2-1. STYLUS TRACKING ANGLE

When setting up the arm for playing, it is important to check the tracking angle, because improper tracking angle will cause distortion and premature record wear. Most phono cartridges are designed so that when the cartridge is mounted on a surface parallel with the record surface, the stylus will track at the proper angle (see Figure 1). The surface inside of the cartridge shell (against which the cartridge is mounted) is parallel to the record surface when the stylus is touching the record surface. Visually check the angle of the tone arm in actual playing position. If it is not level and parallel with the record surface, then it is necessary to change the height of the tone arm by using the spacers supplied with the phono cartridge. This, of course, requires removing and remounting the cartridge, and some trial and error technique. With most cartridges, no spacers will be necessary.

NOTE: Some cartridges are built so that their bodies are at an angle with respect to their own mounting tabs. No attempt should be made to change this angle. Simply make sure that the cartridge mounting tab surfaces are parallel to the tone arm shell mounting surface before proceeding with the arm height adjustment.

2-2. STYLUS OVERHANG

Your Turntable is designed to operate with the least distortion when the tip of the stylus is at a particular distance from tone arm pivot. For this reason, the cartridge shell is slotted, allowing the cartridge with its mounting screws to be slid toward or away from the pivot point. This, in effect, changes the radius of the arc described by the stylus.

Supplied in the accessory kit is a 45 RPM spindle adaptor. The adaptor has been specially marked with an arrow and a cross to aid you in setting the proper stylus overhang. Proceed as follows:

1. With the turntable unplugged, place the 45 RPM adaptor on the center spindle with the arrow pointing to the rear of the turntable.
2. Temporarily remove the counterweight from the tone arm.
3. Remove the arm from its arm rest and remove the protective cover (if any) from the stylus.
4. Place the stylus tip over the cross mark on the 45 RPM adaptor. It is all right for the stylus to gently touch the adaptor for checking purposes, but do not exert any downward pressure on it, or the stylus may be damaged.
5. If the stylus does not align with the cross mark, then adjustment is necessary. Place the arm in the arm rest, loosen the cartridge mounting screws, adjust, and measure again.
6. Make sure that the cartridge is installed straight; the sides of the cartridge must remain parallel to the sides of the shell.
7. When you are sure the cartridge is in the correct position, place the arm in the arm rest and snug up the mounting screws.
8. Replace the counterweight on the tone arm.

2-3. VERTICAL TONE ARM BALANCE

The adjustable counterweight at the end of the tone arm establishes tone arm balance and stylus tracking force. Since no two types of cartridges weigh the same, the balance and tracking force must be adjusted for each cartridge being used.

First, to establish a point of reference, the entire arm assembly (with cartridge installed) must be balanced. If the cartridge has a removable stylus protector, remove it, (as you would to play a record). Release the tone arm from the arm rest.

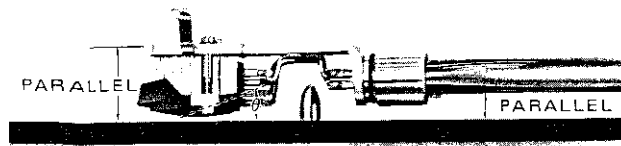

Figure 1 Tracking Angle

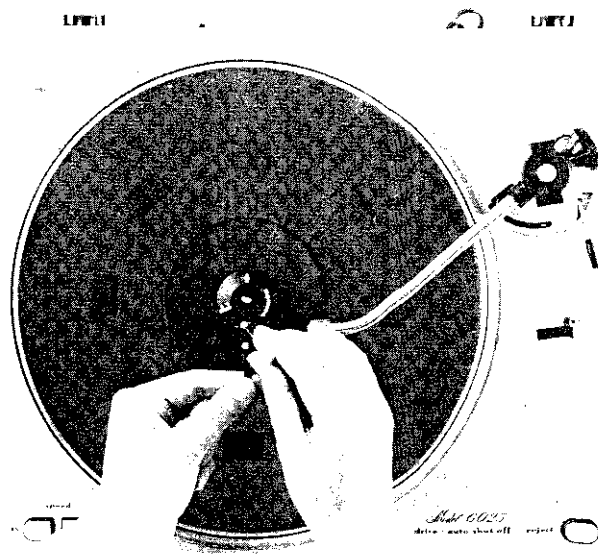

Figure 2 Stylus Overhang Adjustment

To balance the arm, adjust the position of the counterweight by rotating it. A numbered stylus pressure scale plate is located immediately in front of the counterweight. Rotating the scale plate alone does not change the counterweight's position. To change the balance, grasp and turn the counterweight itself.

Adjust the weight so that the arm is level (parallel to the turntable surface) with the cartridge suspended in mid air. Then, without moving the counterweight, set the stylus pressure scale plate to indicate zero. This establishes a reference point for setting the tracking force, which is the next adjustment.

2.4. TRACKING FORCE

For the recommended tracking force, refer to the instructions that accompany the cartridge.

Tracking force, the downward pressure of the stylus against the record, is produced by simply setting the arm off balance in the appropriate direction. That is, the counterweight is screwed inward (toward the arm pivot) until the desired downward pressure is achieved.

The stylus pressure scale plate is in frictional contact with the counterweight, so that they rotate together when the counterweight is turned. The numbers on the scale plate correspond to the tracking force measured in grams. So, if the desired tracking force is two grams, turn the counterweight inward until the stylus pressure scale plate registers 2.

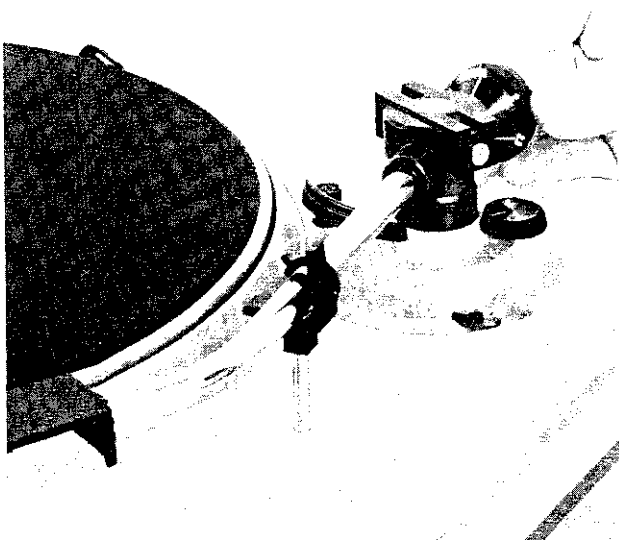

Figure 3 Tone Arm Balance

2.5. ANTI-SKATING ADJUSTMENT

The anti-skating weight is provided to counteract the natural tendency of the arm to "skate" toward the center of the record as it is being played. The more tracking force used, the more anti-skating force required.

The anti-skating force is adjustable with graduations that correspond with the tracking force markings on the stylus pressure scale plate. Set the anti-skating force to the same value as the tracking force. Place the arm in the arm rest.

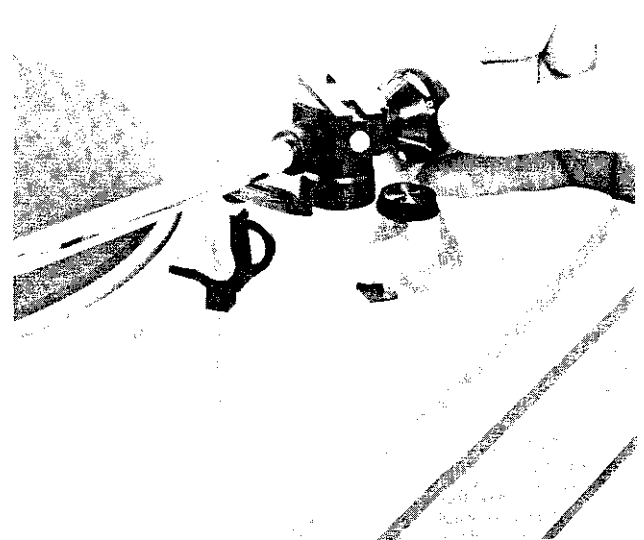

Figure 4 Anti-Skating Adjustment



3. SERVICE NOTES

3-1. VOLTAGE CONVERSION (European Model only)

CAUTION: Disconnect power supply cord from AC outlet before converting voltage.

1. Remove anti-static mat from turntable platter.
2. Locate oval hole in turntable platter and remove belt from motor pulley.
3. Lift turntable platter up and remove.
4. Place the Voltage Selector Switch (S001) in the required voltage position with a screwdriver tip.
5. This version of the Model 6025 (European) is provided with a 50 Hz motor pulley mounted on the motor shaft. When the unit is being converted from 240 V to 120 V operation the 50 Hz pulley must be replaced with a 60 Hz pulley which can be obtained from the Marantz Parts Department.

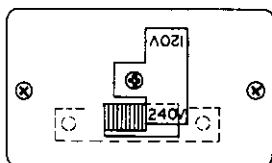
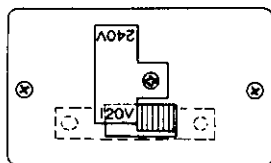

3-2. CARTRIDGE WIRE COLOR CODE

Before a cartridge is screwed into the shell, the small clips at the ends of the wires in the tone arm cartridge shell should be pushed onto their corresponding cartridge connection pins.

— TONE ARM CARTRIDGES SHELL — — WIRE COLOR CODE —

RIGHT CHANNEL HOT RED
 RIGHT CHANNEL GROUND GREEN
 LEFT CHANNEL HOT WHITE
 LEFT CHANNEL GROUND BLUE

The cartridge or its accompanying technical sheet will identify the cartridge connection pins. It may be necessary to slightly compress the terminal clips with your fingers to make them fit snugly on the prongs of some cartridges.

3-3. REPLACEMENT PARTS/TECHNICAL ASSISTANCE

3-3-1. REPLACEMENT PARTS

Turntable replacement parts may be ordered by writing to;

MARANTZ COMPANY, INC.
PARTS DEPARTMENT
P.O. BOX 577
CHATSWORTH, CALIFORNIA 91311 USA

3-3-2. TECHNICAL ASSISTANCE

Inquiries regarding the operation and servicing of Marantz equipment should be directed to;

MARANTZ COMPANY, INC.
TECHNICAL SERVICES DEPARTMENT
P.O. BOX 577
CHATSWORTH, CALIFORNIA 91311 USA

4. DIAGRAM

4-1. SCHEMATIC DIAGRAM

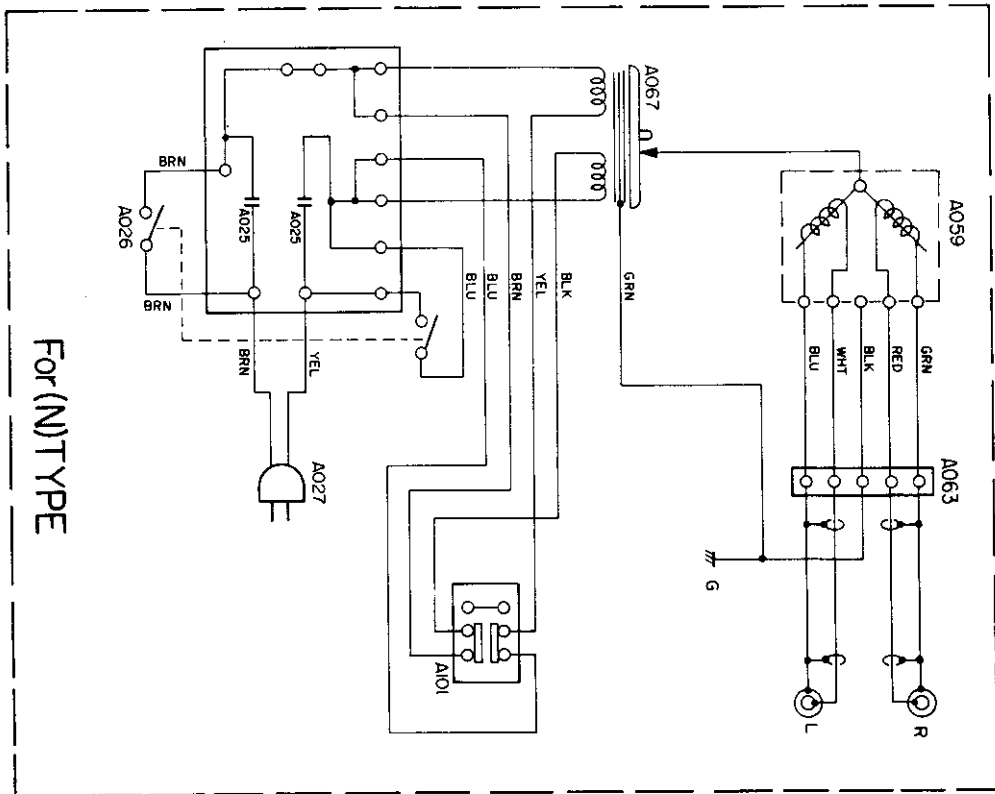
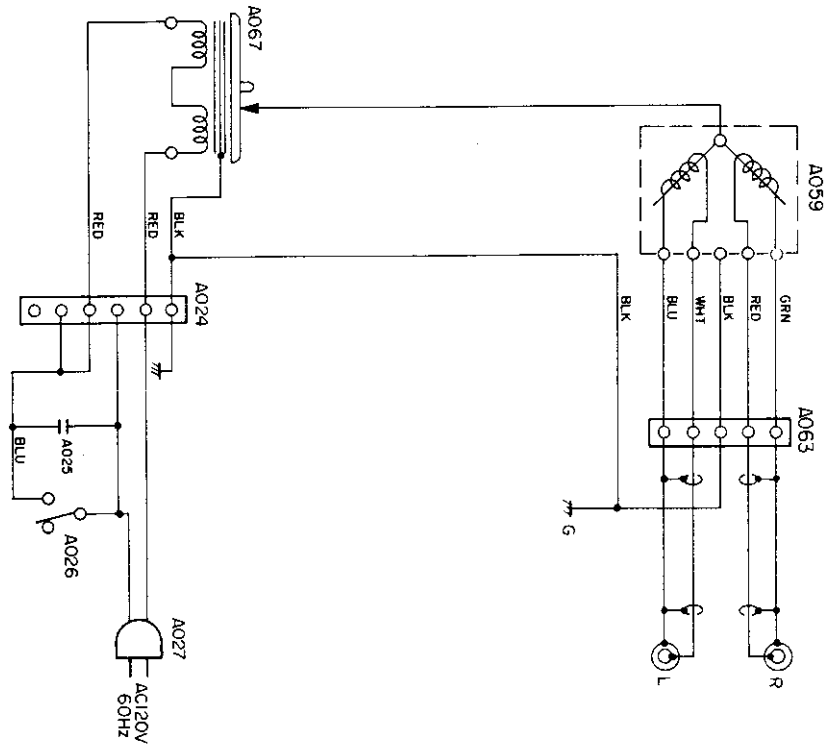

5. EXPLODED VIEWS AND PARTS LIST

5-1. [C01-99] WOOD CASE AND GENERAL PARTS

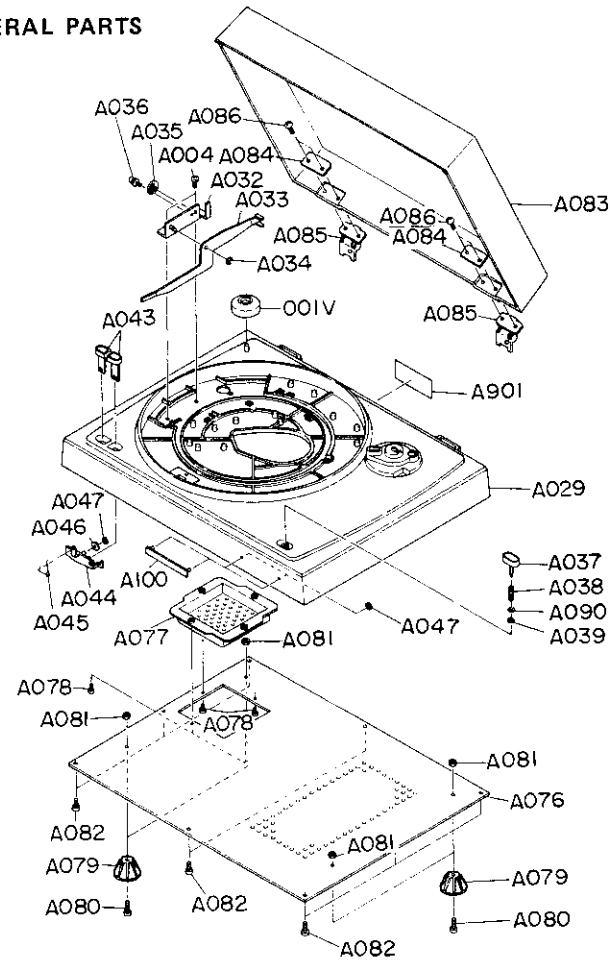

REF. DESIG.	Q'TY			PART NO.	DESCRIPTION
	U	C	N		
A	1	1	1	2477064400	Case Assembly
A029	1	1	1	2477064010	Case
A047	2	2	2	64020300R0	R.G. Ring CS
A100	1	1	1	2477251010	Badge
A901	1			2477265010	Indicator
A901		1		2477265020	Indicator
A901			1	2477265030	Indicator
B	1	1	1	2477053400	Dust Cover Assembly
A083	1	1	1	2477053030	Cover
A084	2	2	2	2477005010	Clamper
A085	2	2	2	2477153010	Hinge
A086	4	4	4	51360408S9	T.H. TAP. Screw
A004	2	2	2	51300308B0	P.H. TAP. Screw
A032	1	1	1	2477160010	Bracket
A033	1	1	1	2477002020	Arm
A034	1	1	1	64003200R0	R.G. Ring
A035	1	1	1	2477054010	Cam
A036	1	1	1	51460308A9	L. Washer Screw
A037	1	1	1	2477154010	Knob
A038	1	1	1	2477115030	Spring

REF. DESIG.	Q'TY			PART NO.	DESCRIPTION
	U	C	N		
A039	1	1	1	64003200R0	R.G. Ring
A043	2	2	2	2477154020	Knob
A044	1	1	1	2477354030	Lever
A045	1	1	1	2477115050	Spring
A046	2	2	2	54020300A0	Flat Washer S
A047	1	1	1	64020300R0	R.G. Ring CS
A076	1	1	1	2477257010	Lid
A077	1	1	1	2477053020	Cover
A078	4	4	4	51300312B0	P.H. TAP. Screw
A079	4	4	4	2477057010	Leg
A080	4	4	4	51440412A9	L Washer Screw
A081	4	4	4	53110403A9	Hexagon Nut
A082	8	4	8	51380412A0	P.H. TAP. Screw
A090	1	1	1	2477118060	Spacer
001V				2272362010	Rec Adaptor

5-2. [P01-99] TURNTABLE AND MOTOR

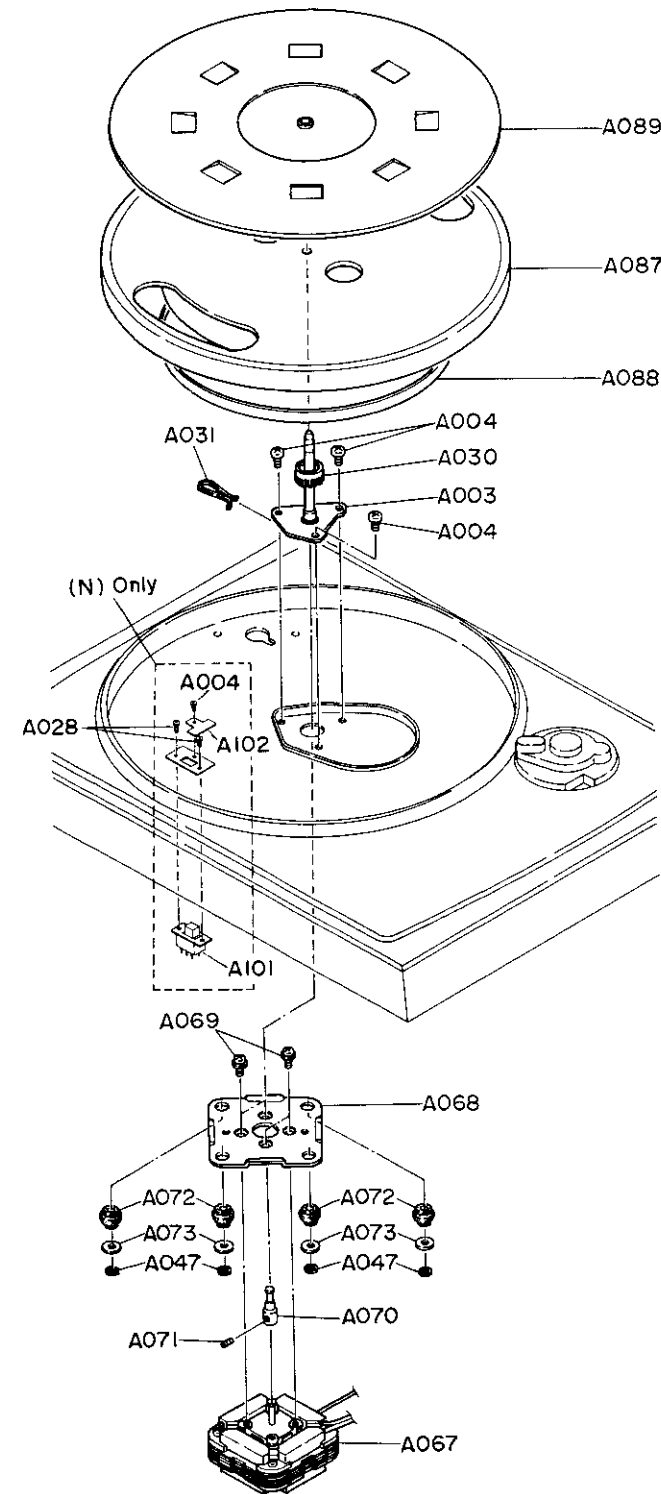

REF. DESIG.	Q'TY			PART NO.	DESCRIPTION
	U	C	N		
A003	1	1	1	2477106500	Sustainer
A004	3	3	4	51300308B0	P.H. TAP. Screw
A030	1	1	1	2477112500	Shaft
A031	1	1	1	2477114010	Stopper
A047	4	4	4	64020300R0	RG Ring, CS
A064	4	4	1	2477262020	Pulley (60 c/s)
A067	1	1		PM12300040	Phonomotor Unit
A067			1	PM12300050	Phonomotor Unit
A068	1	1	1	2477160030	Bracket
A069	4	4	4	51450306A9	F. Washer Screw
A070	1	1		2477262010	Pulley (50 c/s)
A071	1	1	1	51652602A0	Set. Screw CP
A072	4	4	4	2477259010	Bushing
A073	4	4	4	2477118050	Spacer
A087	1	1	1	2477165010	Turn Table
A088	1	1	1	2477264010	Belt
A089	1	1	1	2477107010	Sheet
A101			1	SC02020510	Switch
A102			1	2477265050	Indicator
A028			2	51062614A0	Screw

5-3. [P02-99] TONE ARM

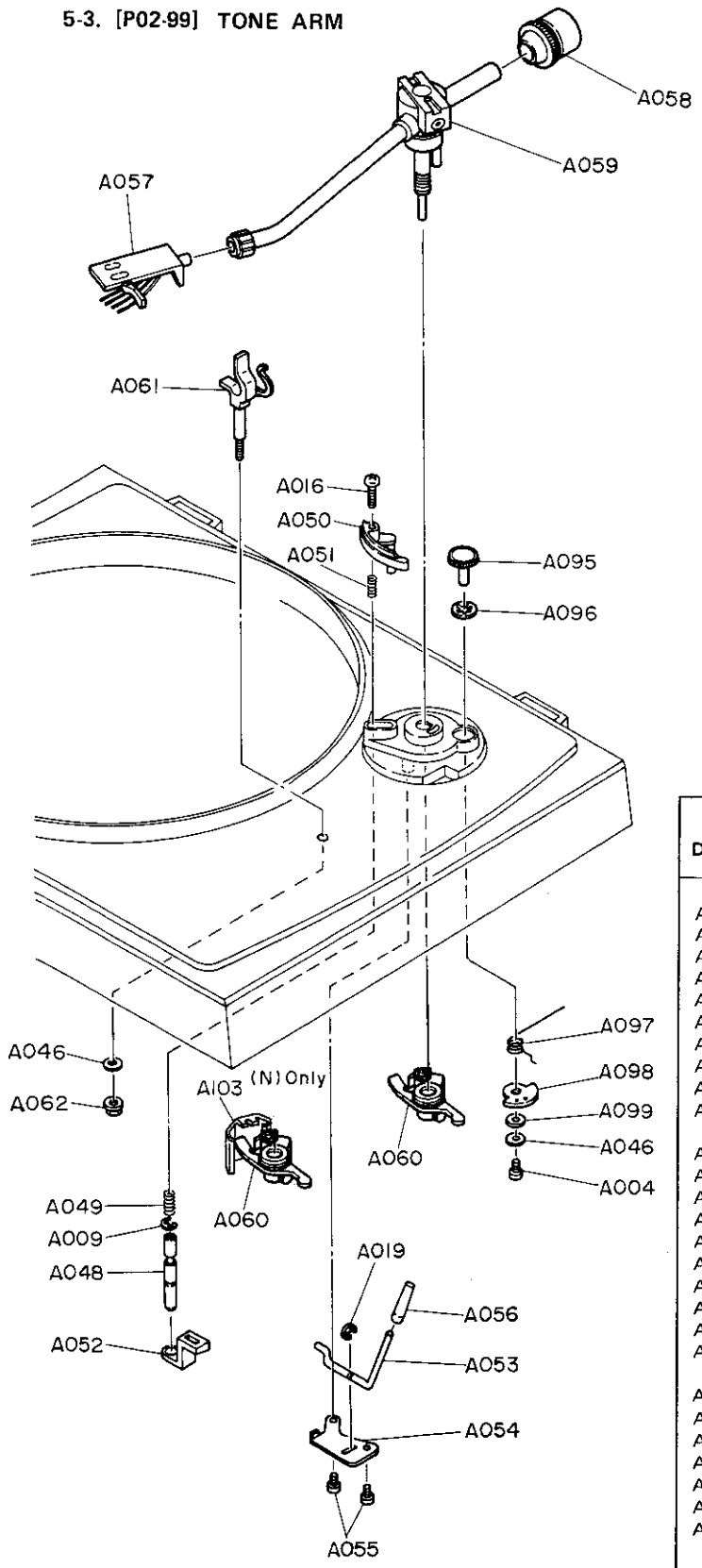

REF. DESIG.	Q'TY			PART NO.	DESCRIPTION
	U	C	N		
A004	1	1	1	51300308B0	P.H. TAP. Screw
A009	1	1	1	64000300R0	RG Ring, E
A016	1	1	1	51060314S9	P.H.M. Screw
A019	1	1	1	64000200R0	RG Ring, E
A046	2	2	2	54020300A0	Flat Washer P
A048	1	1	1	2477112020	Shaft
A049	1	1	1	2477115060	Spring
A050	1	1	1	2477354040	Lever
A051	1	1	1	2477115070	Spring
A052	1	1	1	2477002030	Arm
A053	1	1	1	2477354050	Lever
A054	1	1	1	2477160020	Bracket
A055	2	2	2	51380204P0	P.H. TAP. Screw
A056	1	1	1	2477067010	Cap
A057	1	1	1	YS02040130	Head Shell
A058	1	1	1	2477008010	Weight
A059	1	1	1	PA12216010	Tone Arm
A060	1	1	1	2477002040	Arm
A060	1	1	1	2477002050	Arm
A061	1	1	1	2477005500	Clamper
A062	1	1	1	53110303A9	Hexagon Nut
A095	1	1	1	2477154030	Knob
A096	1	1	1	2477115080	Spring
A097	1	1	1	2477115090	Spring
A098	1	1	1	2477054020	Cam
A099	1	1	1	2477118020	Spacer
A103			1	2477053050	Cover

5-4. [P03-99] PARTS ASSEMBLED ON THE CHASSIS

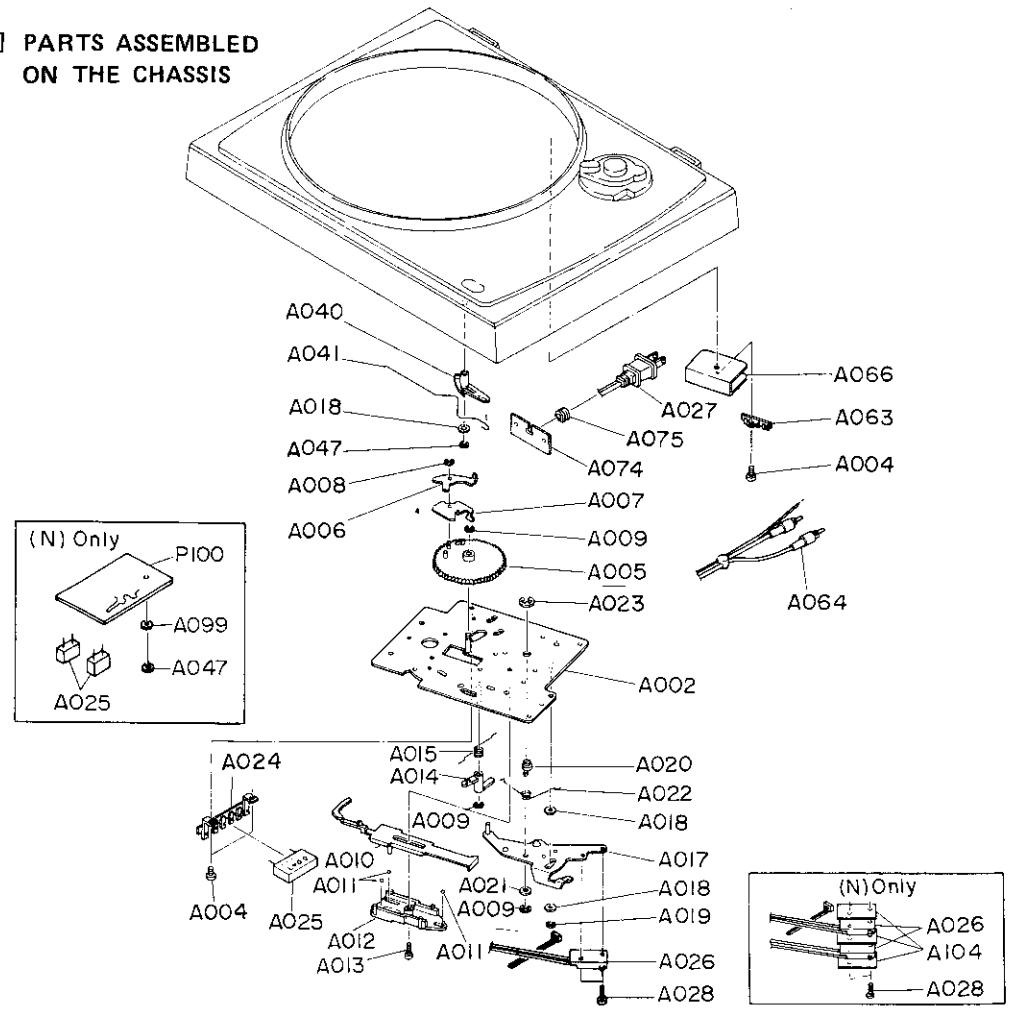

REF. DESIG.	Q'TY			PART NO.	DESCRIPTION
	U	C	N		
A002	1	1	1	2477105500	Chassis K
A004	3	3	3	51300308B0	P.H. TAP. Screw
A005	1	1	1	2477058010	Gear
A006	1	1	1	2477061010	Clutch
A007	1	1	1	2477061020	Clutch
A008	1	1	1	64000300R0	RG Ring, E
A009	3	3	3	64000300R0	RG Ring, E
A010	1	1	1	2477002010	Arm
A011	3	3	3	61040010C0	Ball
A012	1	1	1	2477004010	Table
A013	1	1	1	51300312B0	P.H. TAP. Screw
A014	1	1	1	2477354010	Lever
A015	1	1	1	2477115010	Spring
A017	1	1	1	2477354500	Lever
A018	3	3	3	2477118030	Spacer
A019	1	1	1	64000200R0	RG Ring, E
A020	1	1	1	2477112010	Shaft
A021	1	1	1	2477118040	Spacer
P100			1	YD24770010	P.W. Board
			1	ZZ24770010	P.W. Board Assembly

REF. DESIG.	Q'TY			PART NO.	DESCRIPTION
	U	C	N		
A022	1	1	1	2477115020	Spring
A023	1	1	1	64070600R0	RG Ring
A024	1	1	1	YL01060030	Terminal
A025	1	1	1	DF17473600	Film Cap
A025			2	DF17223800	Film Cap
A026	1	1	1	SM01020150	Switch
A026			2	SM01020340	Switch
A027	1	1	1	YC02000140	AC Cord
A027			1	YC01800160	AC Cord
A028	2	2	2	51062614A0	P.H.M. Screw
A040	1	1	1	2477354020	Lever
A041	1	1	1	2477115040	Spring
A047	1	1	2	64020300R0	RG Ring, CS
A063	1	1	1	YL01050030	Terminal
A066	1	1	1	2477109010	Shield
A074	1	1	1	2477160040	Bracket
A075	1	1	1	1455259030	Bushing
A064	1	1	1	YB01000060	Connective Cord
A099			1	2477118020	Spacer
A104			3	2477120050	Insulator

5-5. [H01-99] PACKING MATERIALS

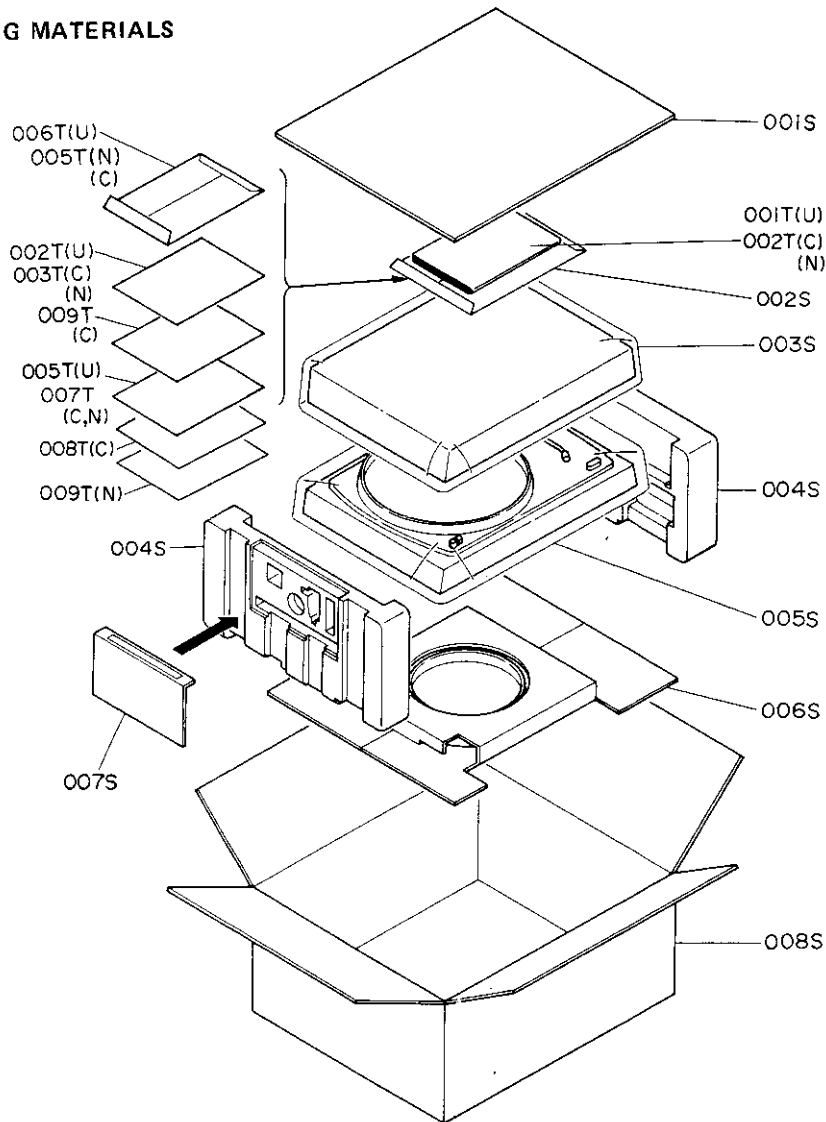

REF. DESIG.	Q'TY			PART NO.	DESCRIPTION
	U	C	N		
001S	1	1	1	2477807010	Reinforcement
002S	1	1	1	9013025010	Polythy Bag
003S	1	1	1	2477811010	Polythy Bag
004S	2	2	2	2477809010	Cushion
005S	1	1	1	9090909040	Polyth Sheet
006S	1	1	1	9013540010	Polyth Sheet
007S	1	1	1	2477807020	Reinforcement
008S	1	1	1	2477801010	Packing Case
001T	1			2477851010	Instructions
002T	1			2477851020	Instructions
002T			1	2477851310	Instructions
002T		1		2477851010	Instructions
003T		1		2477851020	Instructions
003T			1	2477851030	Instructions

REF. DESIG.	Q'TY			PART NO.	DESCRIPTION
	U	C	N		
005T	1			2818854023	Guarantee Card
005T		1		2918813012	Envelope
005T			1	2818813010	Envelope
006T	1			2225813010	Envelope
007T		1	1	9630000180	(IBM Card) Guarantee Card
008T		1		9650000053	S. Station Cord
009T			1	9560000043	Hang Tag
009T		1		2818854042	Guarantee Card

W01-99	Assembly and Wiring
T01-99	Adjustment
X01-00	Correction